

COMPANY:	CLASSE AUDIO INC.		
TITLE:	CLASSE 4/4L PREAMPLIFIERS		
DESC:	FLOW DIAGRAM		
DRAWING NO:	4DIA-1		
DRAWN:	DJR	DATE:	MAR.7/91.
		SHEET:	1 OF 2

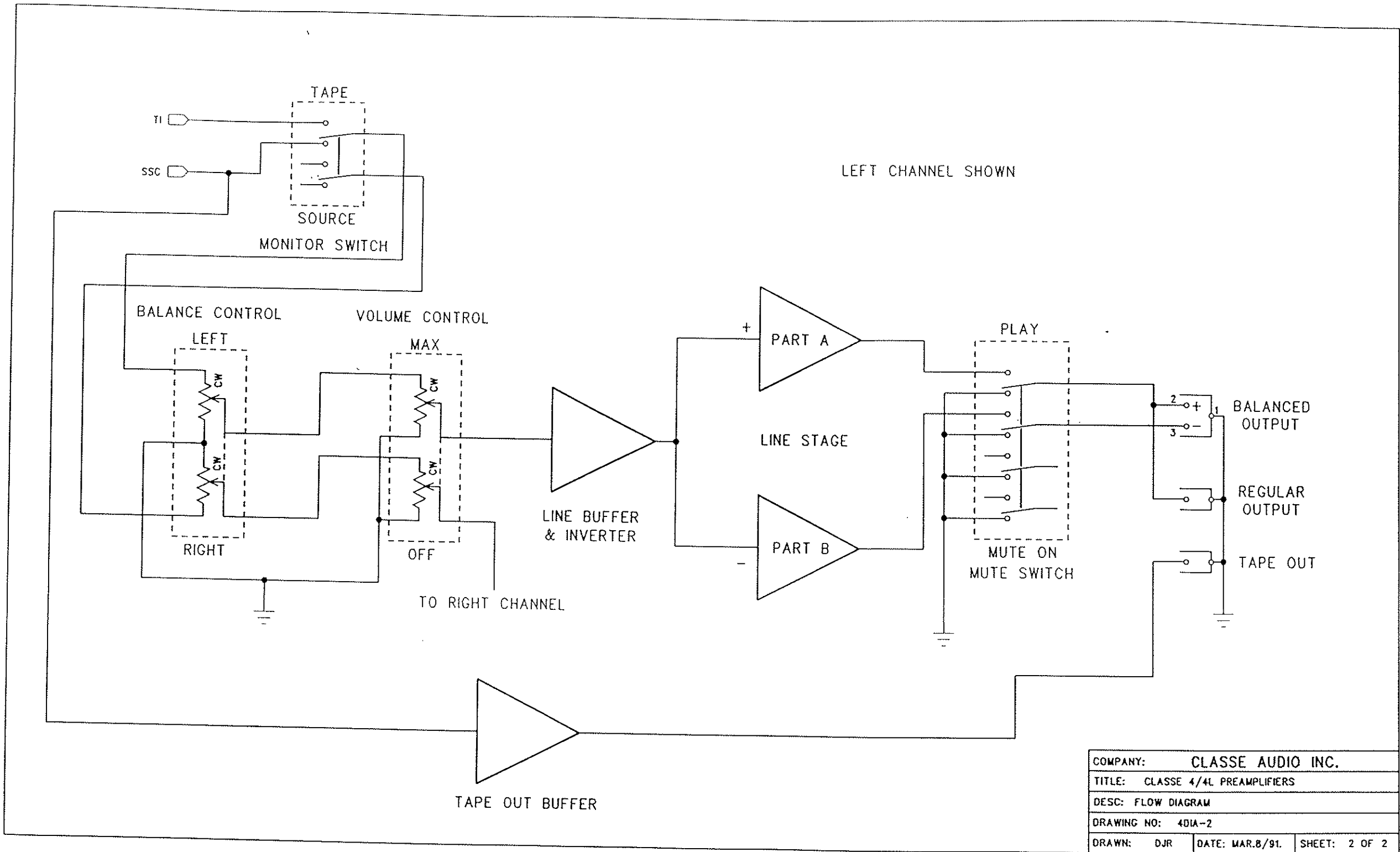

COMPANY: CLASSE AUDIO INC.	
TITLE: CLASSE 4/4L PREAMPLIFIERS	
DESC: FLOW DIAGRAM	
DRAWING NO: 4DIA-2	
DRAWN: DJR	DATE: MAR.8/91. SHEET: 2 OF 2

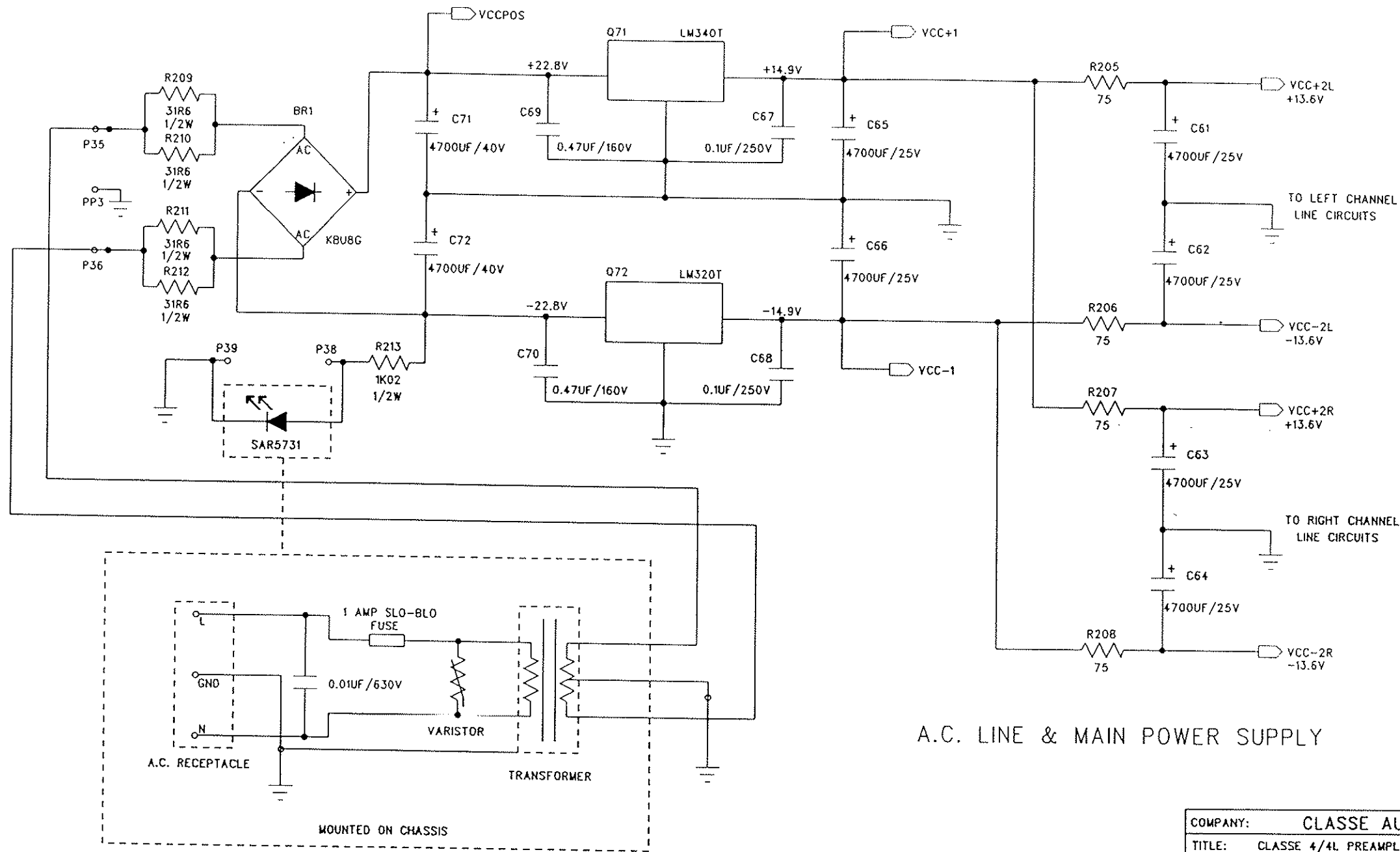

A.C. LINE & MAIN POWER SUPPLY

COMPANY: CLASSE AUDIO INC.	
TITLE: CLASSE 4/4L PREAMPLIFIERS	
DESC: A.C. LINE & MAIN POWER SUPPLY	
DRAWING NO: 4PS-1	
DRAWN: DJR	DATE: JAN.29/91 SHEET: 1 OF 5

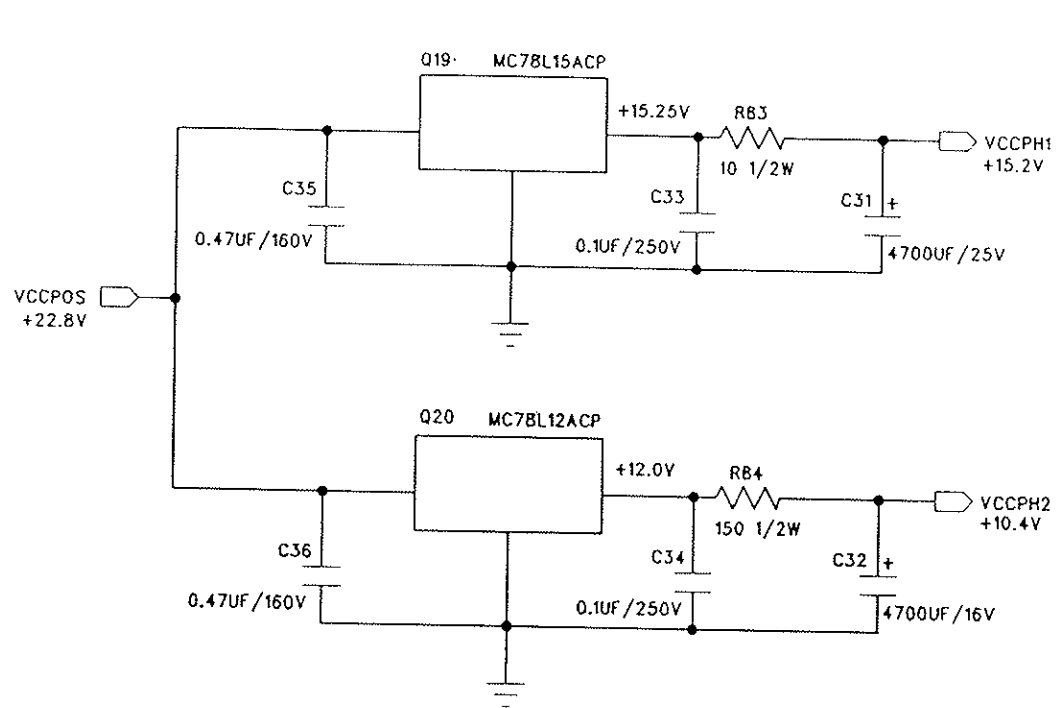

PHONO POWER SUPPLY (BOTH CH.)

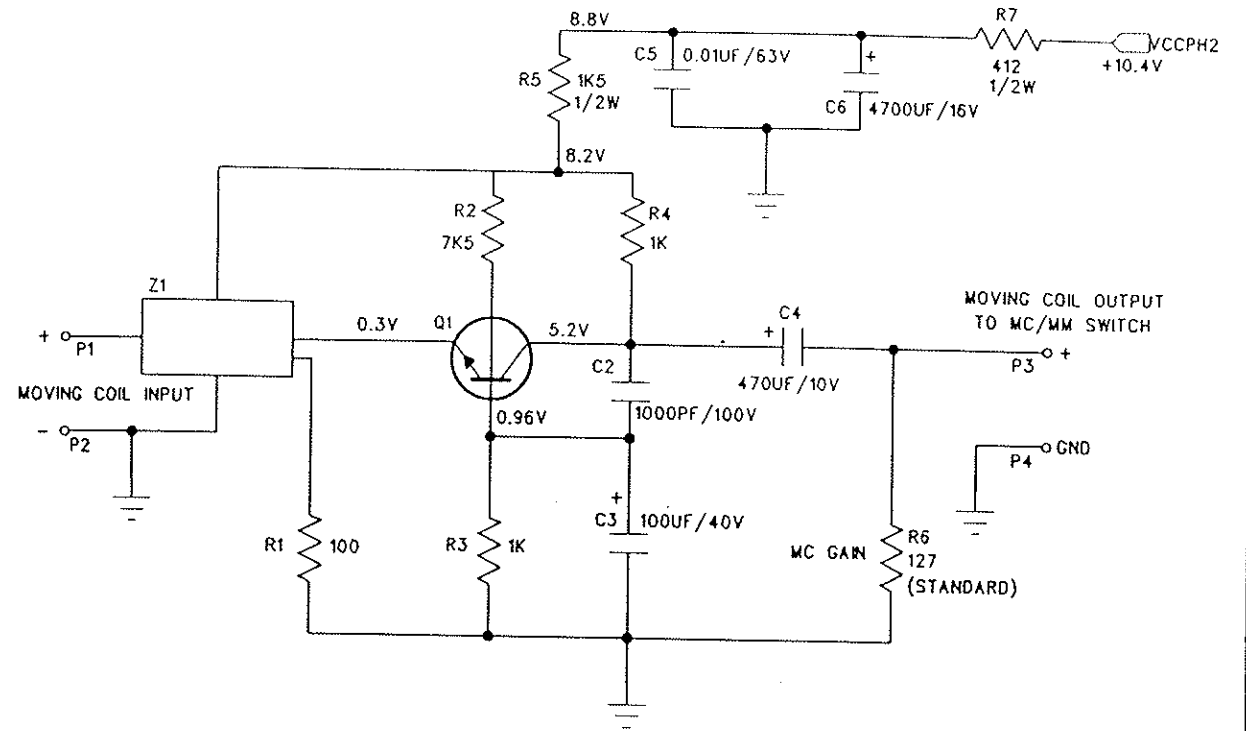

MOVING COIL PHONO (LEFT CH.)

REVISIONS:

PART NUMBER	WAS	IS	DATE
C2	3300PF/63V	1000PF/100V	JUL. 4/91.

COMPANY:	CLASSE AUDIO INC.		
TITLE:	CLASSE 4/4L PREAMPLIFIERS		
DESC:	PHONO POWER SUPPLY; MOVING COIL PHONO		
DRAWING NO:	4MC-2		
DRAWN:	DJR	DATE:	JAN.29/91 SHEET: 2 OF 5

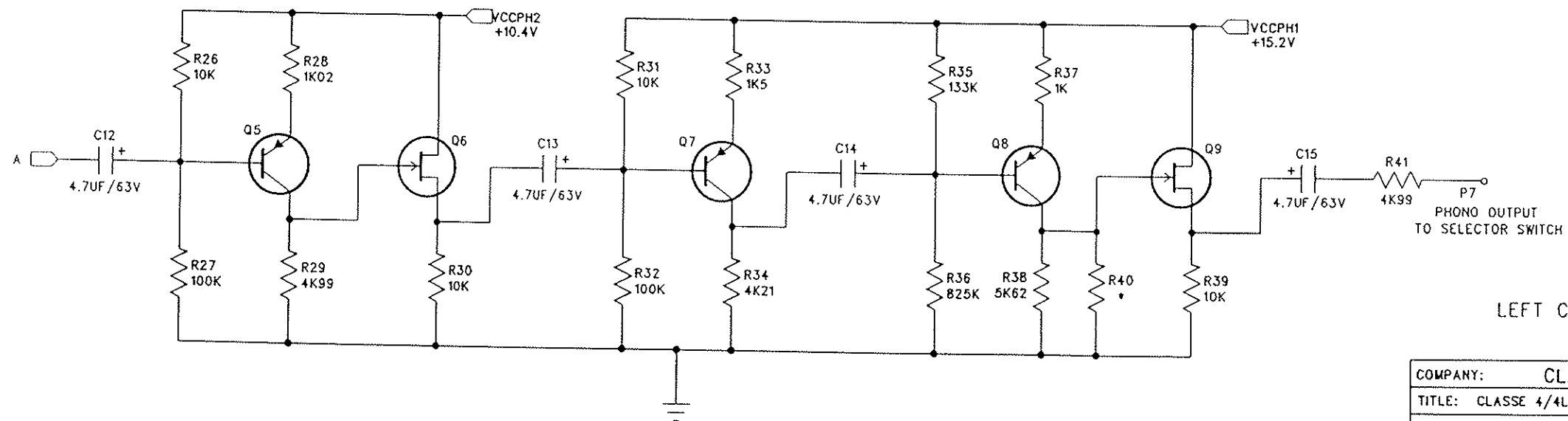
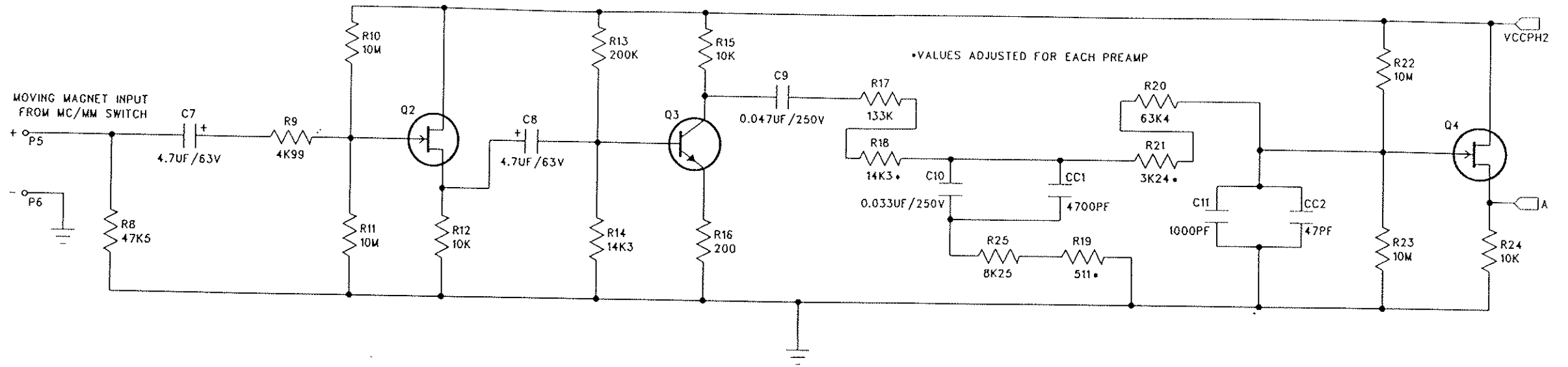

LEFT CHANNEL SHOWN

COMPANY: CLASSE AUDIO INC.		
TITLE: CLASSE 4/4L PREAMPLIFIERS		
DESC: MOVING MAGNET PHONO		
DRAWING NO: 4MM-3		
DRAWN: DJR	DATE: JAN.29/91.	SHEET: 3 OF 5

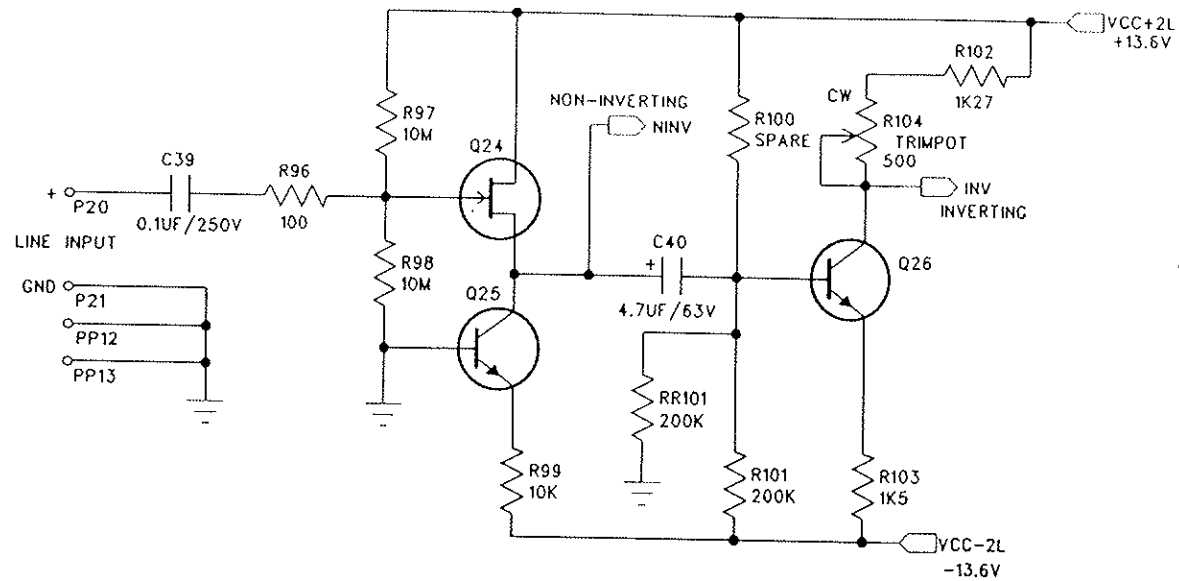

LINE BUFFER & INVERTER (LEFT CH.)

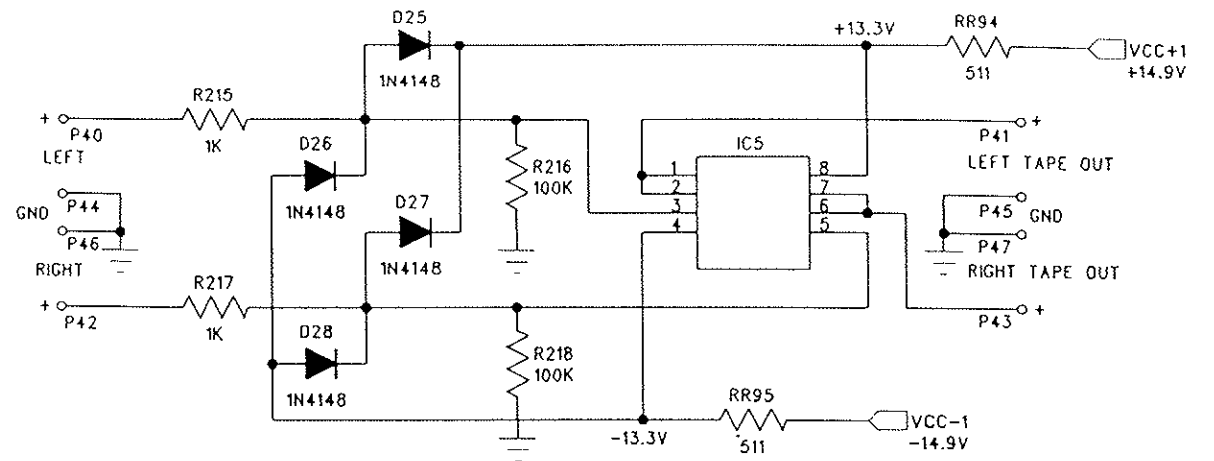

TAPE OUT BUFFER (BOTH CH.)

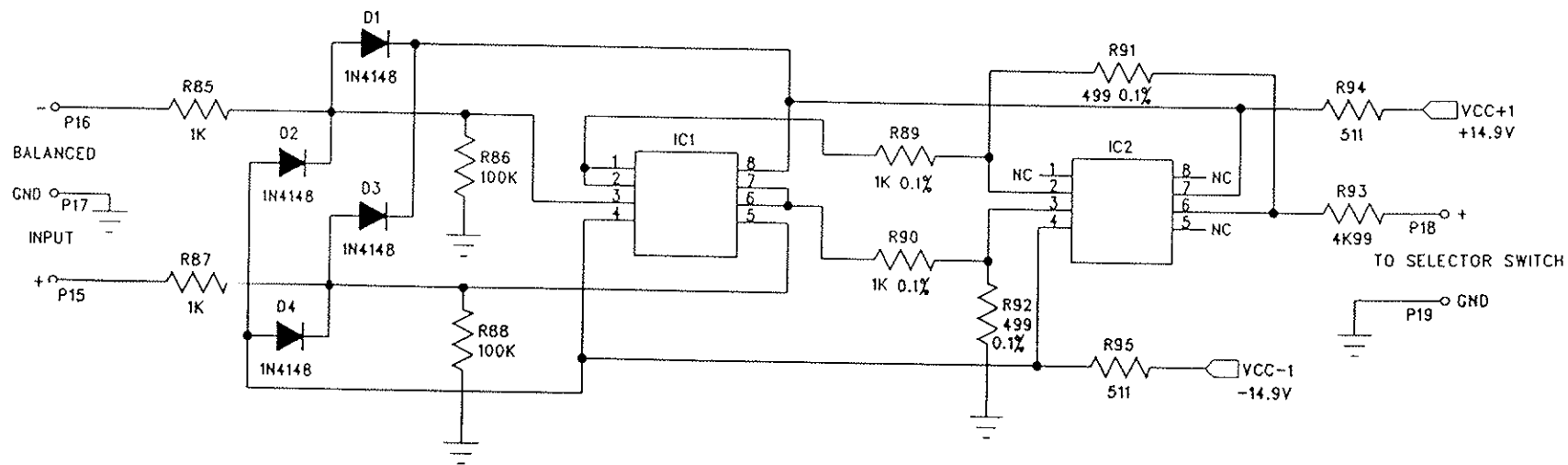

BALANCED INPUT (LEFT CH.)

REVISIONS:

PART NUMBER	WAS	IS	DATE
R100	100K	SPARE	JUL.4/91
R101	10K	200K	JUL.4/91
RR101	SPARE	200K	JUL.4/91

COMPANY: CLASSE AUDIO INC.			
TITLE: CLASSE 4/4L PREAMPLIFIERS			
DESC: LINE BUFFER & INVERTER; BALANCED INPUT; TAPE OUT BUFFER			
DRAWING NO: 4BUF-4			
DRAWN: DJR	DATE: JAN.29/91	SHEET: 4 OF 5	

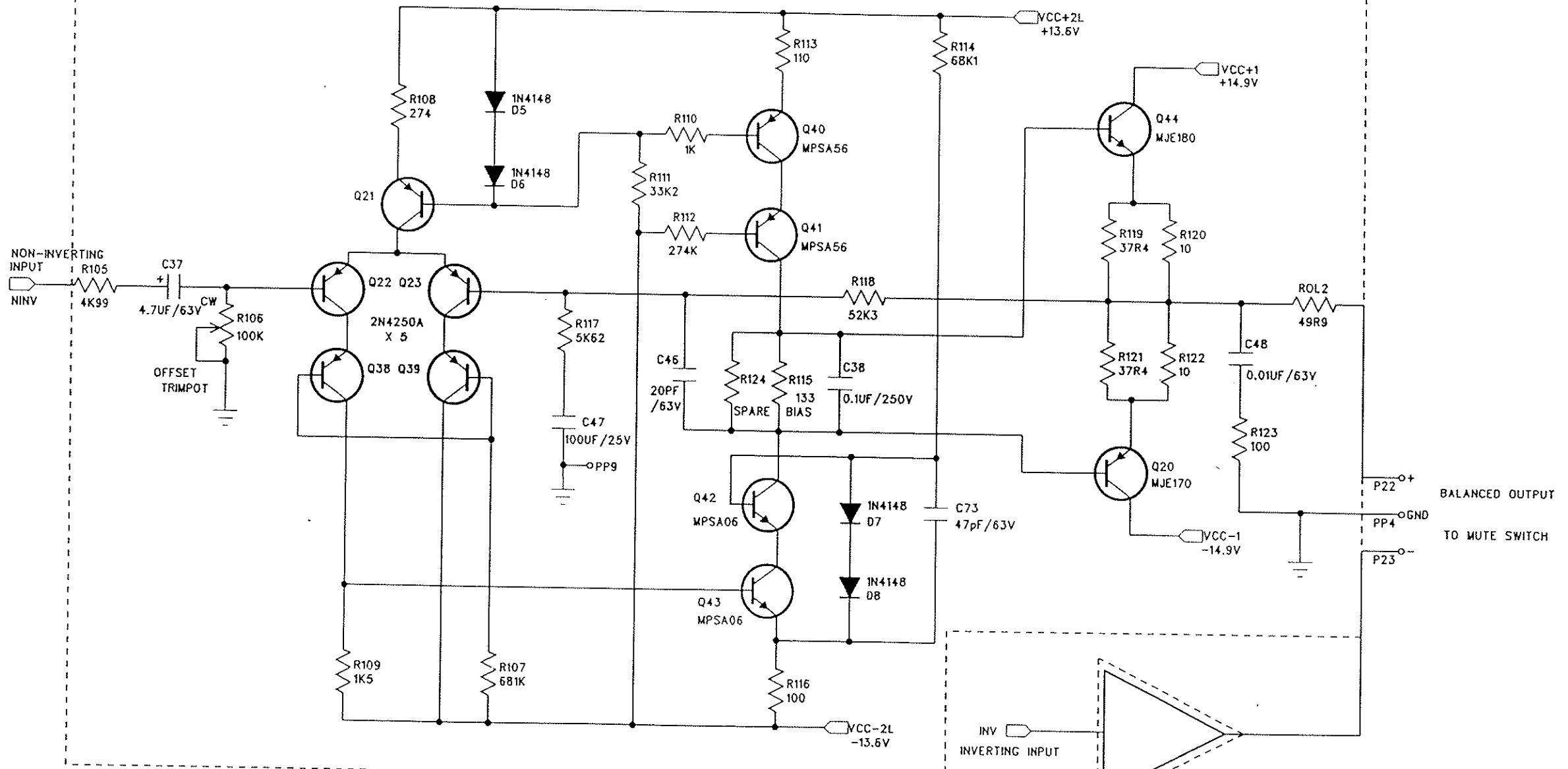

PART A

LEFT CHANNEL SHOWN

PART B
(IDENTICAL TO PART A)

COMPANY:		CLASSE AUDIO INC.	
TITLE:		CLASSE 4/4L PREAMPLIFIERS	
DESC:		LINE STAGE	
DRAWING NO:		4LS-5	
DRAWN:	DJR	DATE:	JAN.29/91
		SHEET:	5 OF 5

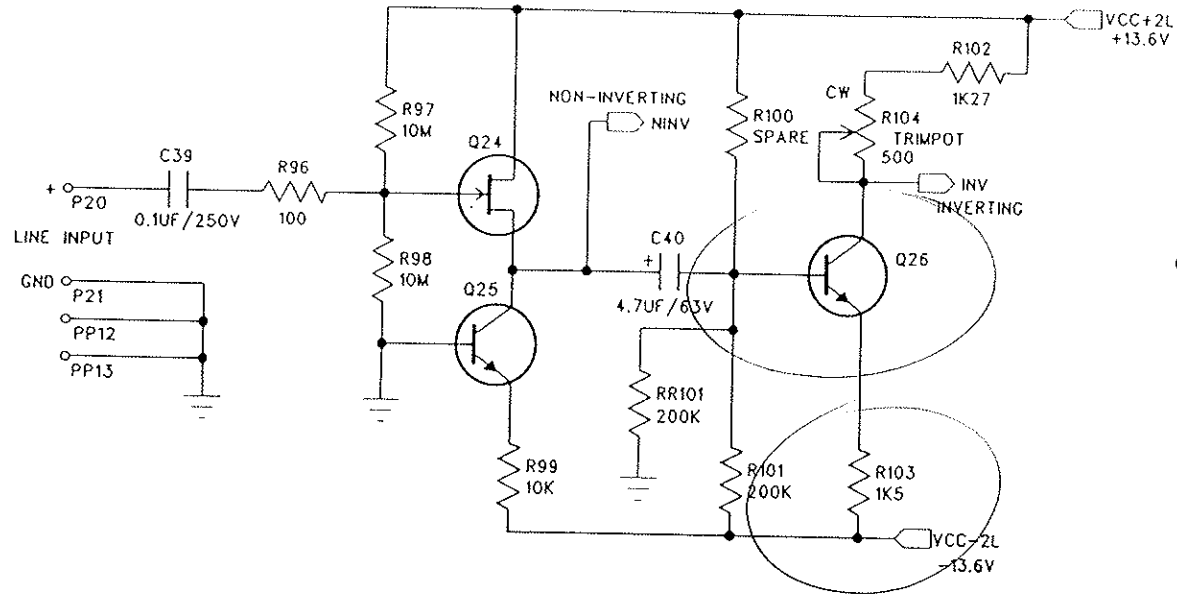

LINE BUFFER & INVERTER (LEFT CH.)

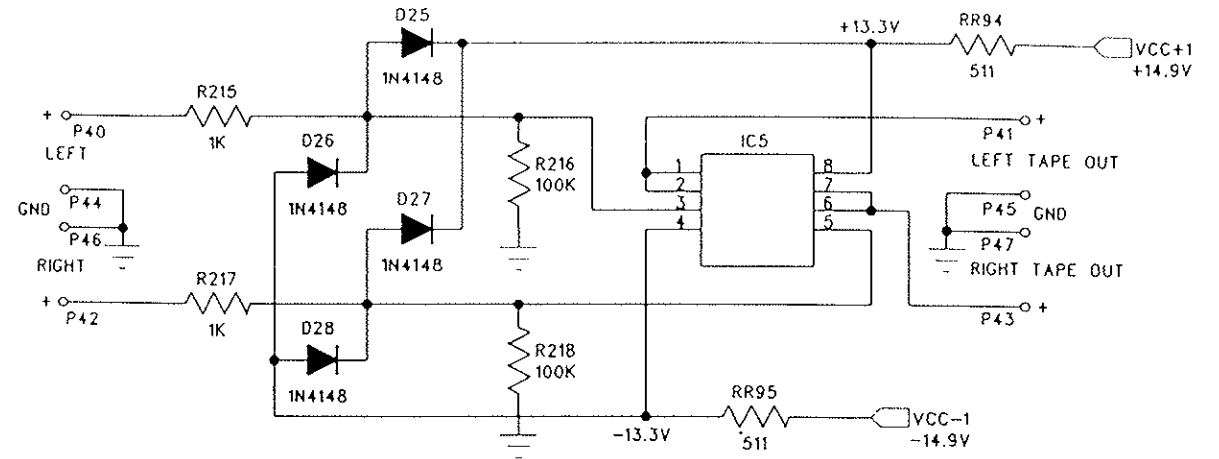

TAPE OUT BUFFER (BOTH CH.)

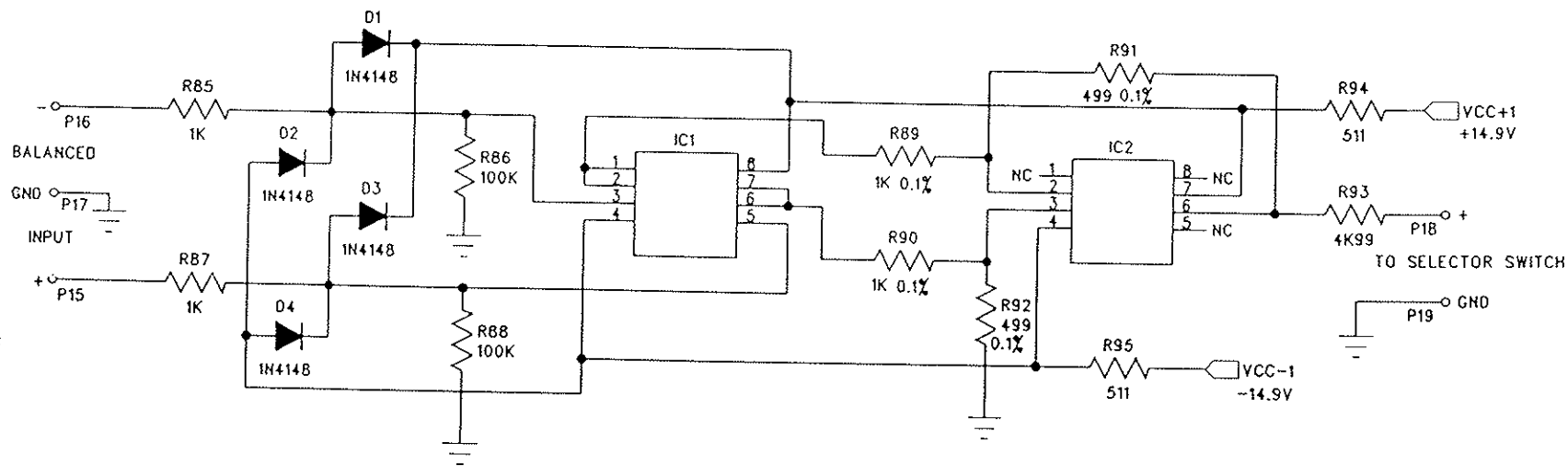

BALANCED INPUT (LEFT CH.)

REVISIONS:

PART NUMBER	WAS	IS	DATE
R100	100K	SPARE	JUL.4/91
R101	10K	200K	JUL.4/91
RR101	SPARE	200K	JUL.4/91

COMPANY: CLASSE AUDIO INC.			
TITLE: CLASSE 4/4L PREAMPLIFIERS			
DESC: LINE BUFFER & INVERTER; BALANCED INPUT; TAPE OUT BUFFER			
DRAWING NO: 4BUF-4			
DRAWN: DJR	DATE: JAN.29/91	SHEET: 4 OF 5	

INSTRUCTIONS FOR CONVERSION OF CLASSE-4/5
TO NEW OPERATING LINE VOLTAGE.

- 1_ DISCONNECT UNIT FROM A.C. LINE.
- 2_ REMOVE TOP.
- 3_ DESOLDER ALL WIRES FROM TRANSFORMER TO AC INLET & FUSE HOLDER.
- 4_ RE-CONNECT WIRES AS FOLLOW:
 - * FOR 100VAC & 120VAC :
 - (YELLOW + WHITE) TO SIDE OF FUSE HOLDER.
 - (BLUE + BLACK) TO NEUTRAL ON AC INLET.
 - * FOR 220VAC & 240VAC :
 - WHITE TO SIDE OF FUSE HOLDER.
 - BLUE TO NEUTRAL ON AC INLET.
 - SOLDER YELLOW & BLACK TOGETHER. COVER SOLDER JOIN WITH HEAT-SHRINK OR ELECTRICAL TAPE.
- 5_ REPLACE THE VARISTOR (V1) FOR NEW LINE VOLTAGE:
 - * FOR 100V TO 120V : 221.
 - * FOR 220V TO 240V : 391 OR 441.

NOTE: - IF VARISTOR IS NOT AVAILABLE THEN REMOVE OLD VARISTOR AND LEAVE IT EMPTY.

 - ON CLASSE-4 THE VARISTOR IS LOCATED ON THE AC INLET; THE VARISTOR OF CLASSE-5 IS LOCATED ON THE RIGHT CONNER OF THE PCB.
- 6_ RE-ASSEMBLE UNIT.

