

**Classé**



**SSP-75**

**PREAMPLIFIER / PROCESSOR**

**SERVICE MANUAL**  
**v 1.0**



# Index

---

Mechanical Assembly	3
PC Boards	12
Testing Procedures	18
Diagrams	21

**SSP-75**

**MECHANICAL  
ASSEMBLY**

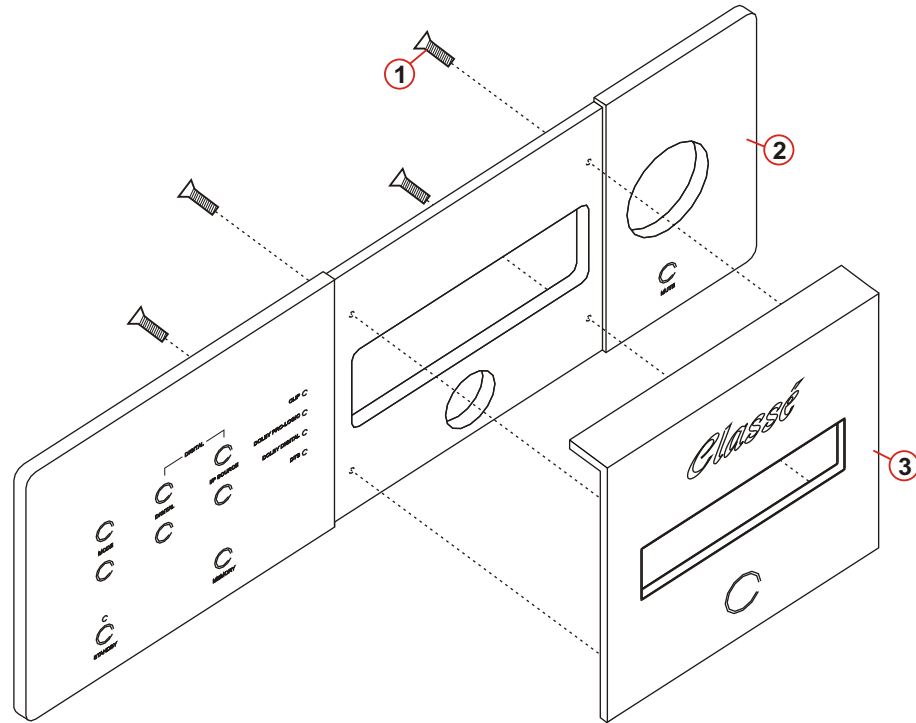

- 1 MS-2347 PHILIPS
- 2 L273XR01
- 3 L274XR03

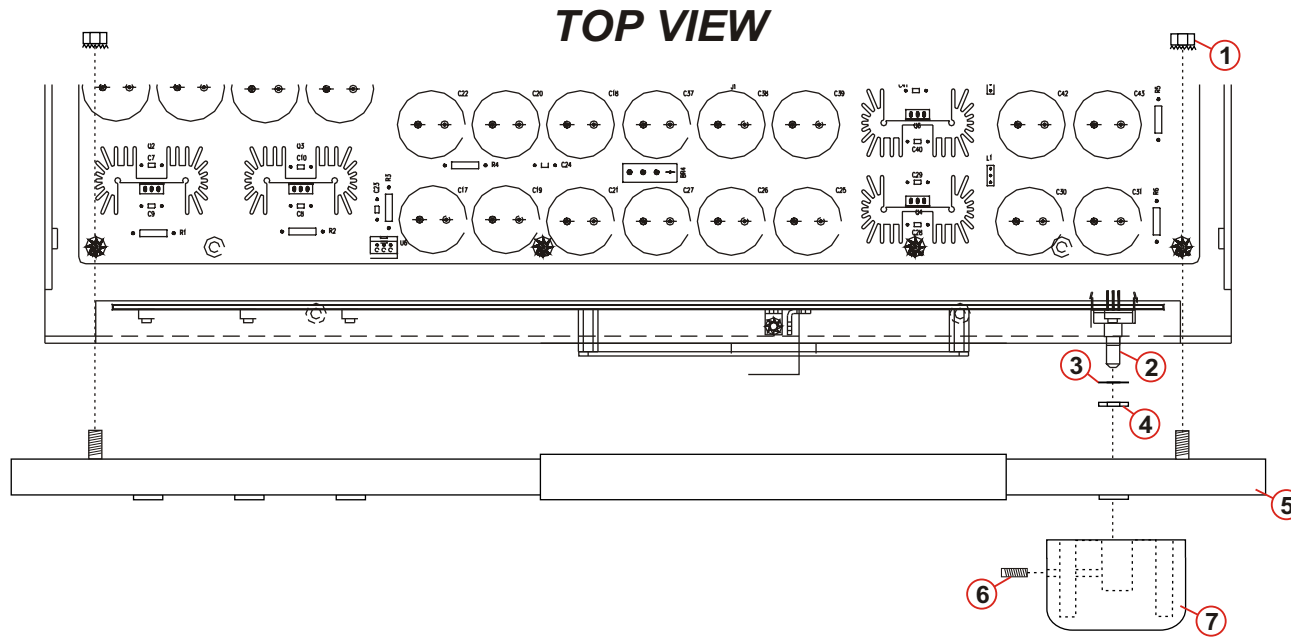

- 1 N-4K
- 2 SDB161PVB20F
- 3 Flat Washer
- 4 Nut
- 5 L273XR01
- 6 6-32 x 1/4 SHSS
- 7 L214XR01-S

# CHASSIS REAR VIEW

SSP-75

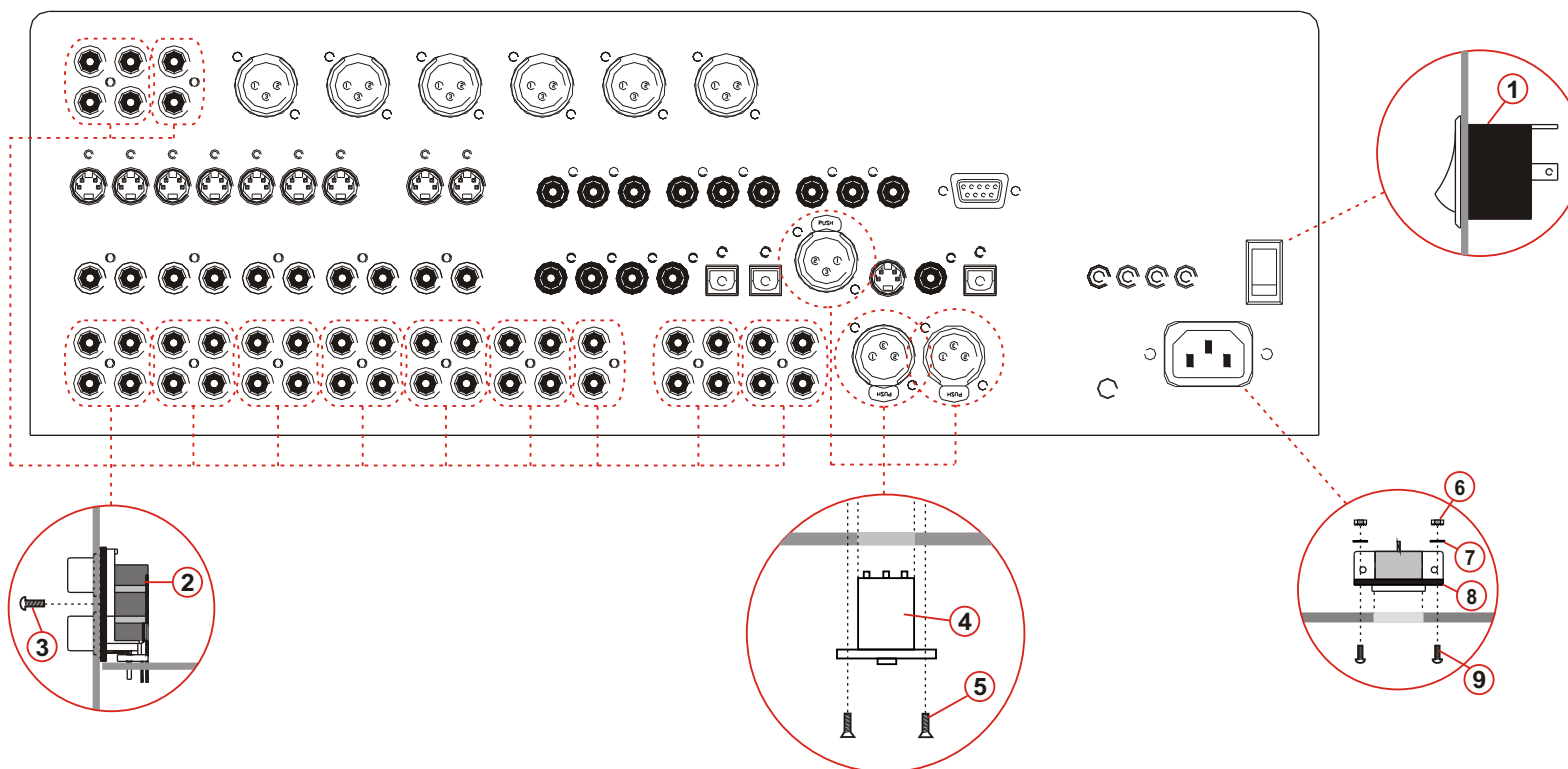

- 1 D501-J12-S2-15-DQ
- 2 Jack
- 3 4-40 x 3/8 BHCS
- 4 Balanced
- 5 4-40 x 3/8 BHCS

- 6 N-1K
- 7 656-042
- 8 EAC-333
- 9 6-32 x 3/8 BHCS

# CHASSIS REAR VIEW

SSP-75

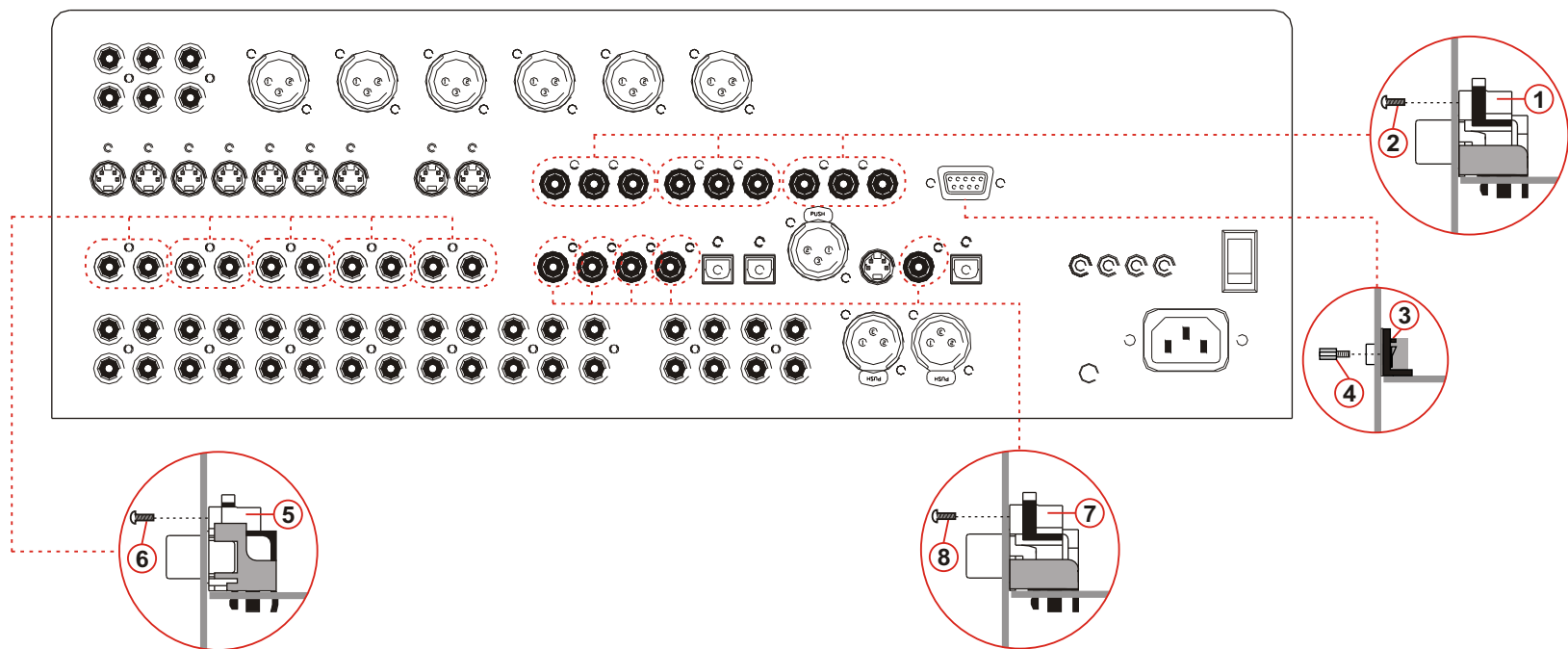

- 1 Jack
- 2 4-40 x 3/8 BHCS
- 3 Jack
- 4 Standoff

- 5 Jack
- 6 4-40 x 3/8 BHCS
- 7 Jack
- 8 4-40 x 3/8 BHCS

# CHASSIS REAR VIEW

SSP-75

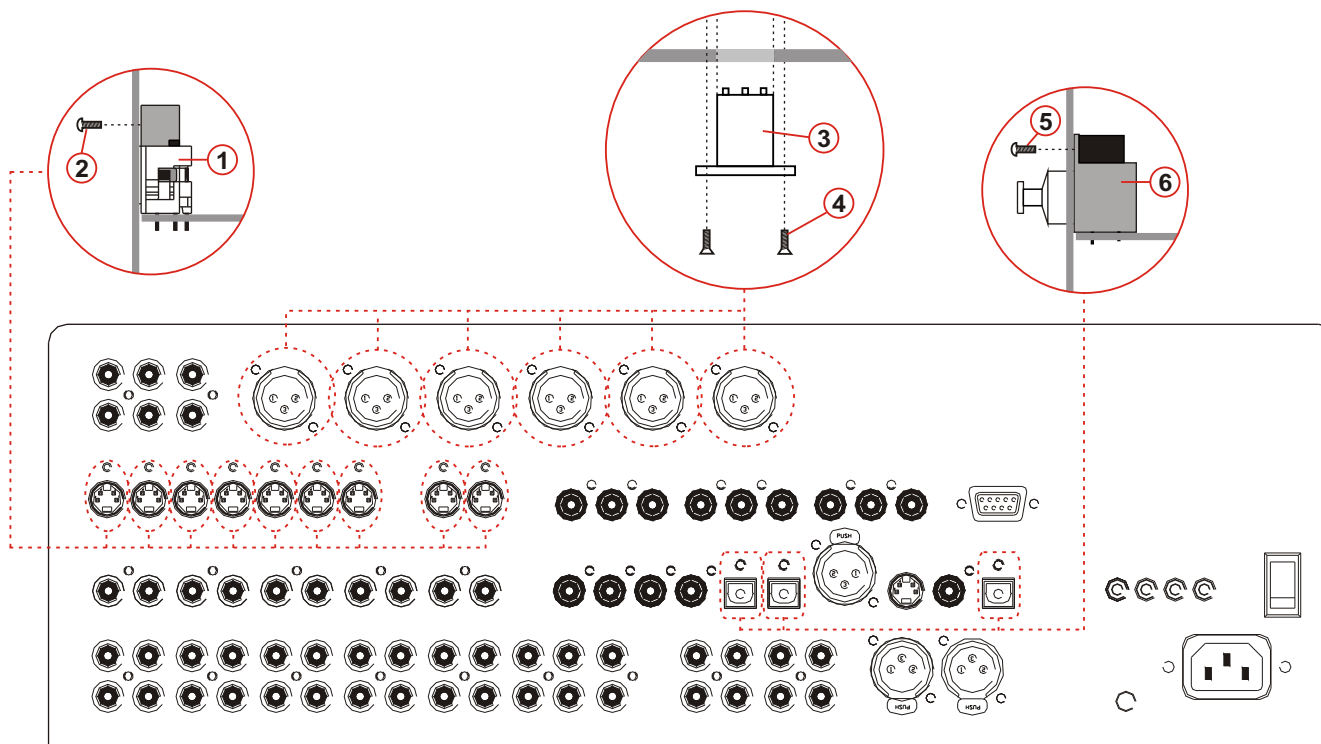

- 1 Jack
- 2 4-40 x 3/8 BHCS
- 3 NC3MAH2
- 4 4-40 x 3/8 BHCS
- 5 4-40 x 3/8 BHCS
- 6 Toslink Connector



**TOP VIEW**

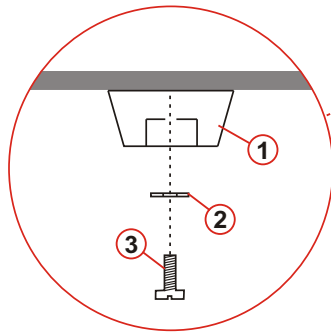
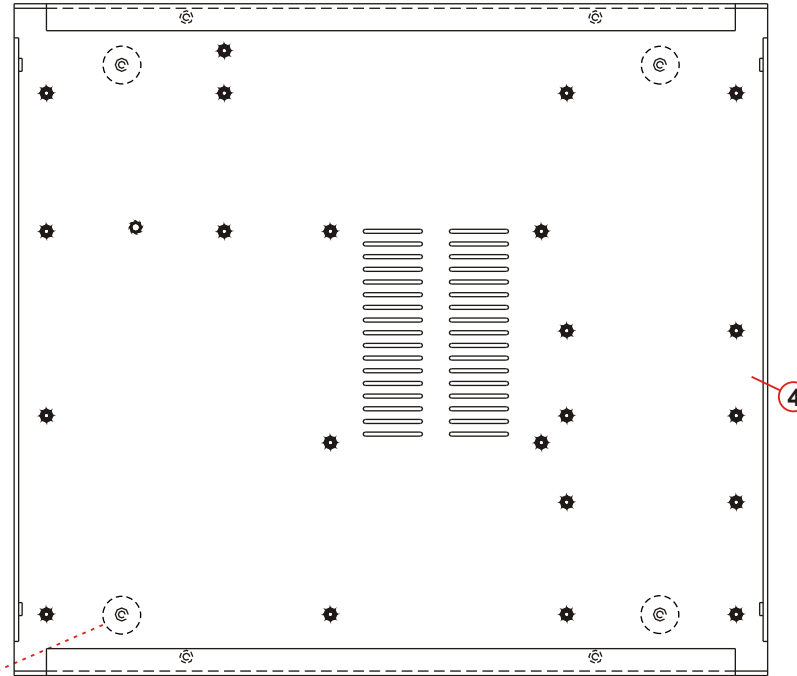

- 1 PLA CAPFR1
- 2 HDW #8 FLAT WASHER
- 3 BZO 8-32x3/4" BHCS
- 4 L271XR03

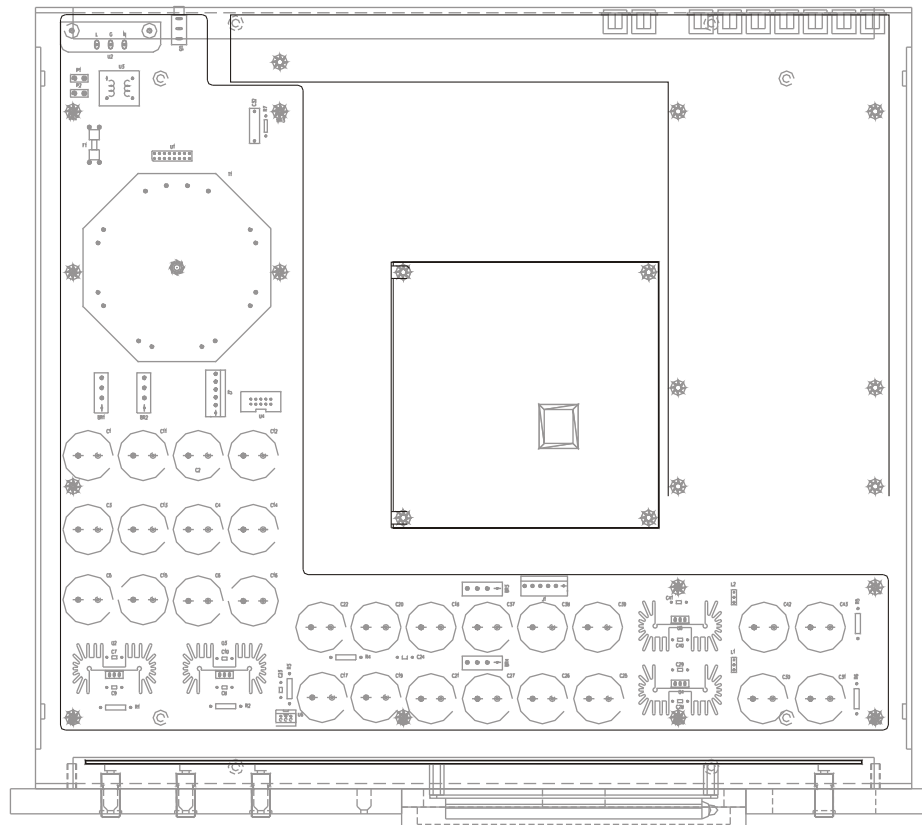
**TOP VIEW**

- 1 AVR BO51XR02
- 2 AVR BO50XR03
- 3 AVR BO1CXR00
- 4 TRANSFORMER

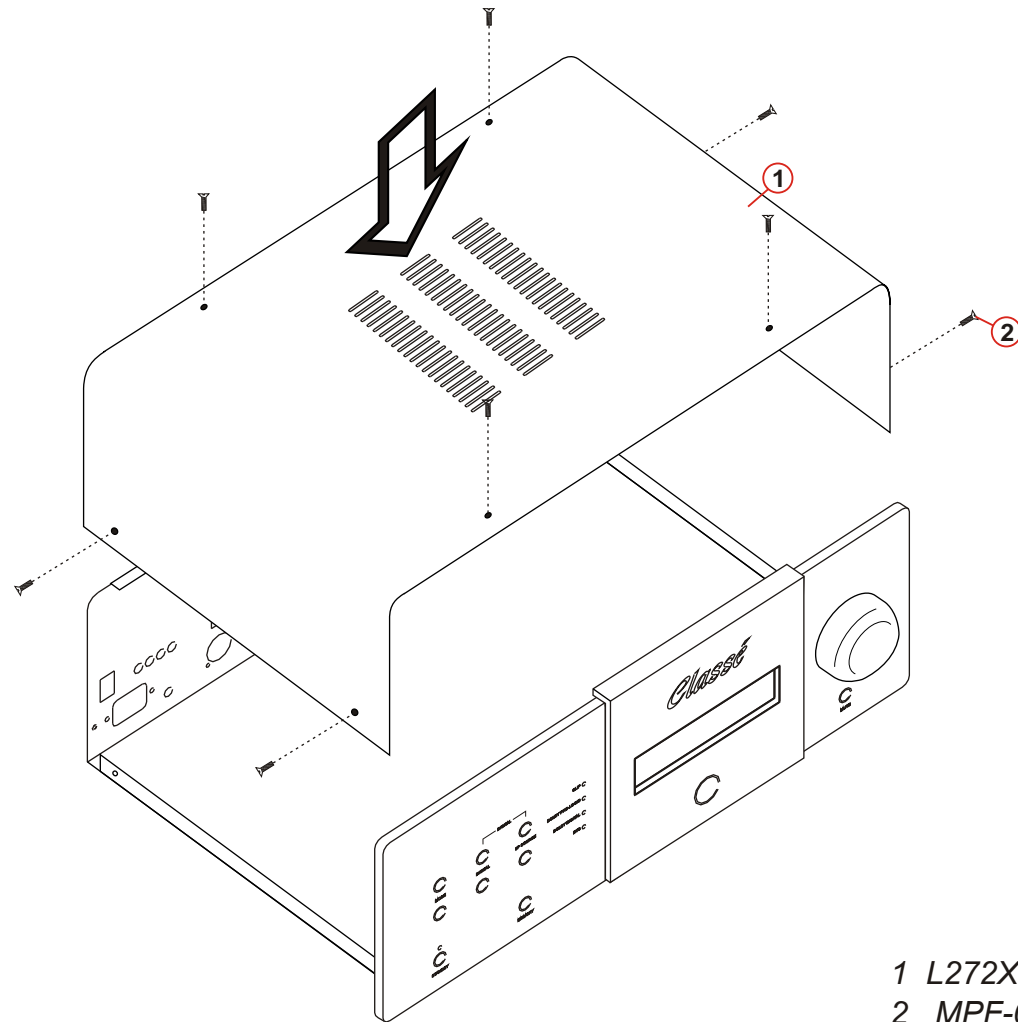

**SSP-75**

**PC BOARDS**

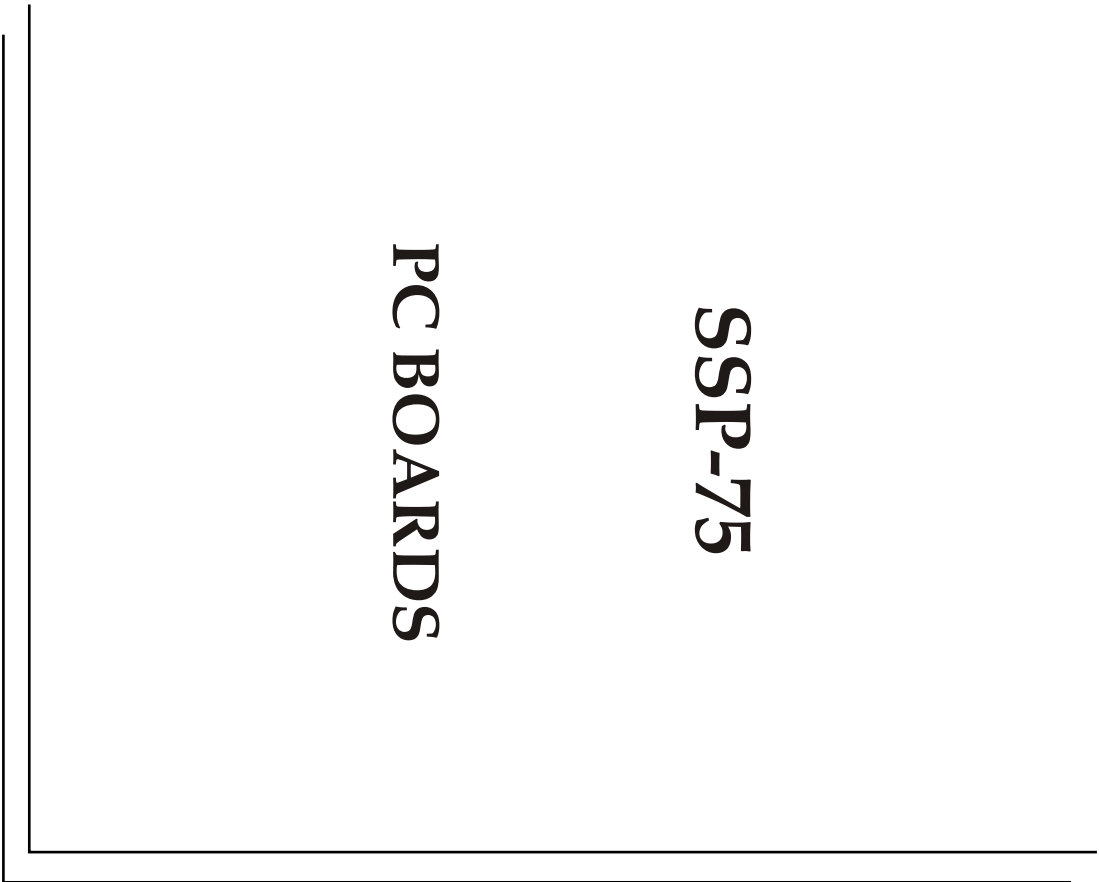

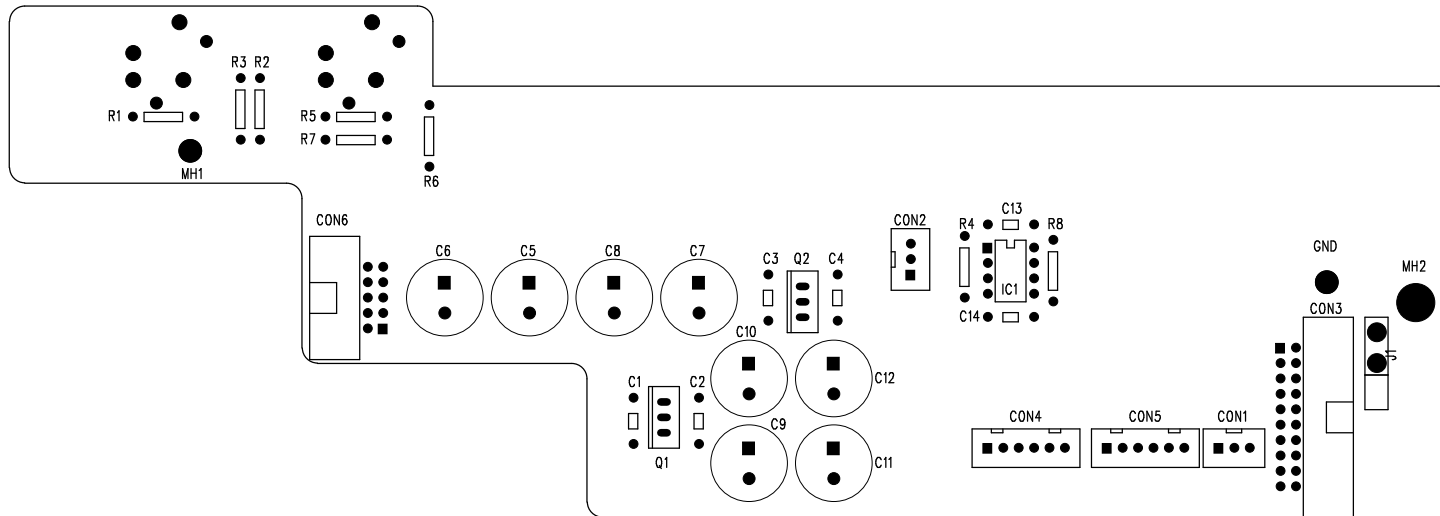

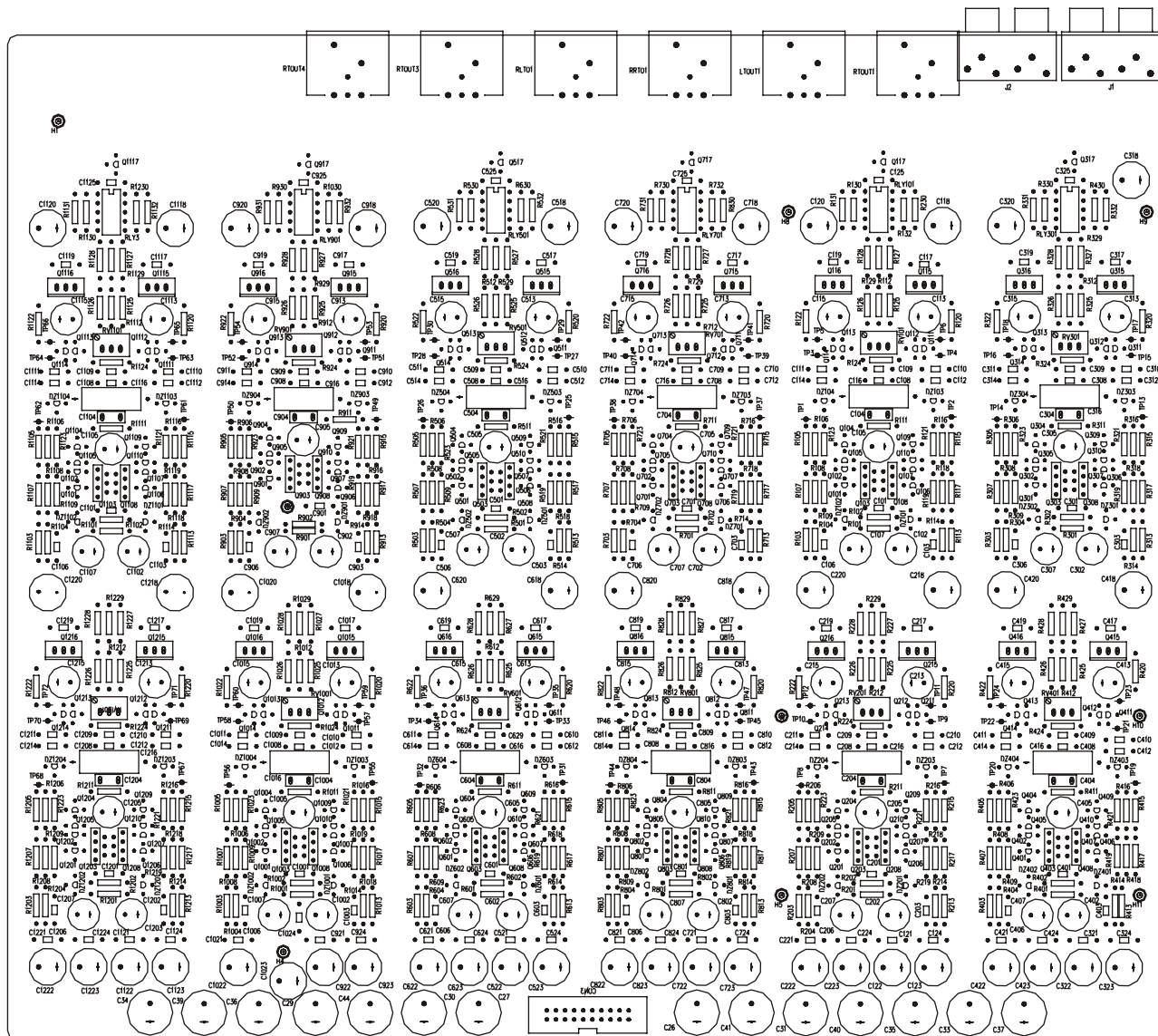

# B275XR01 POWER SUPPLY

SSP-75

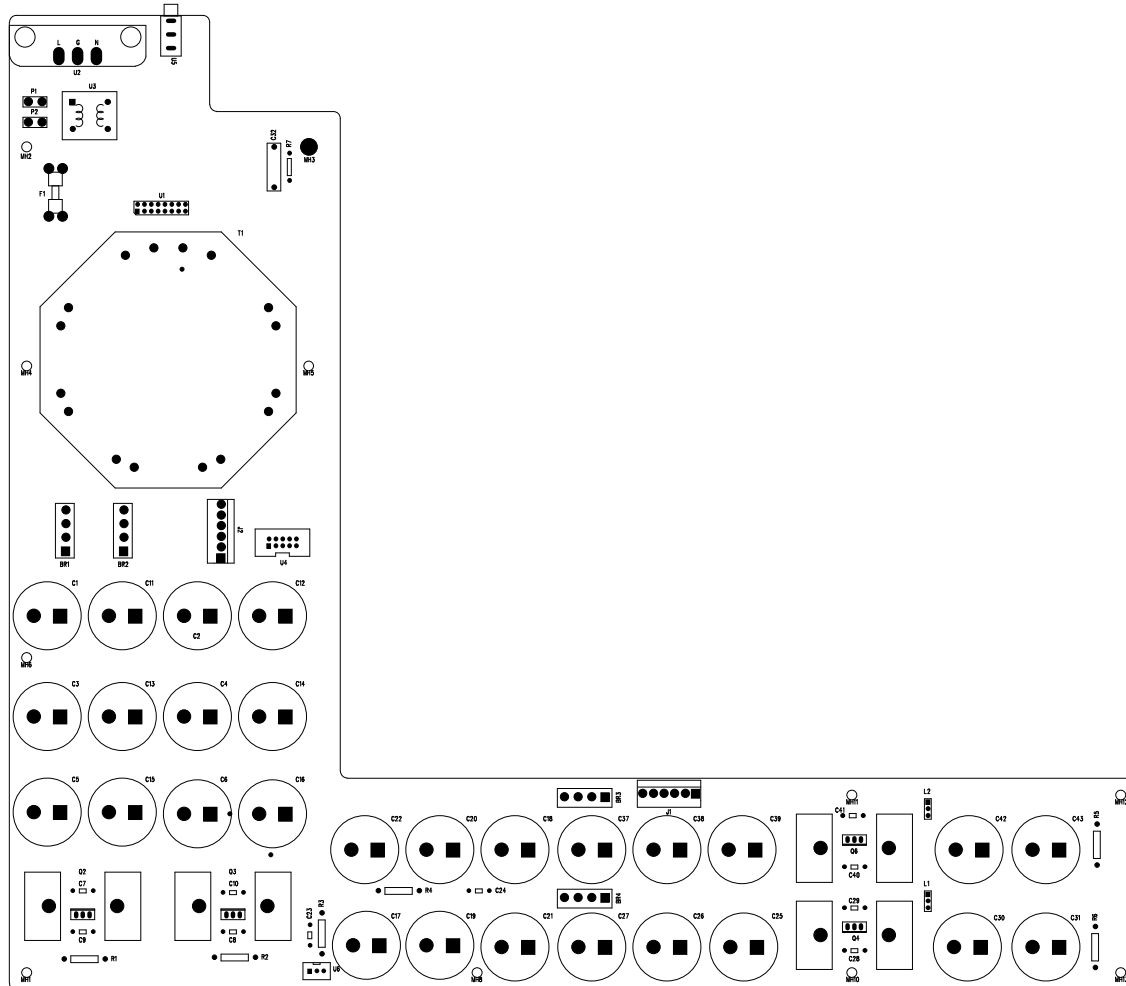

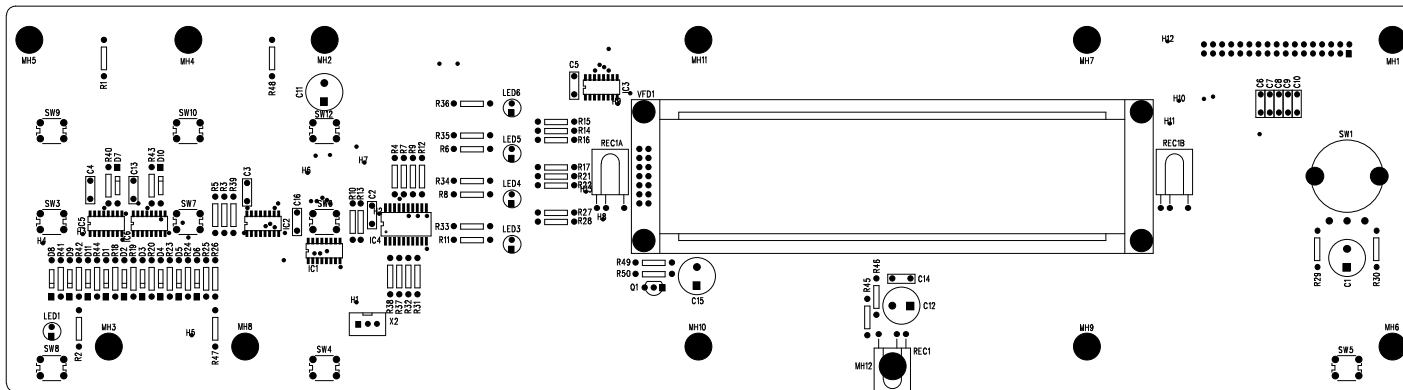



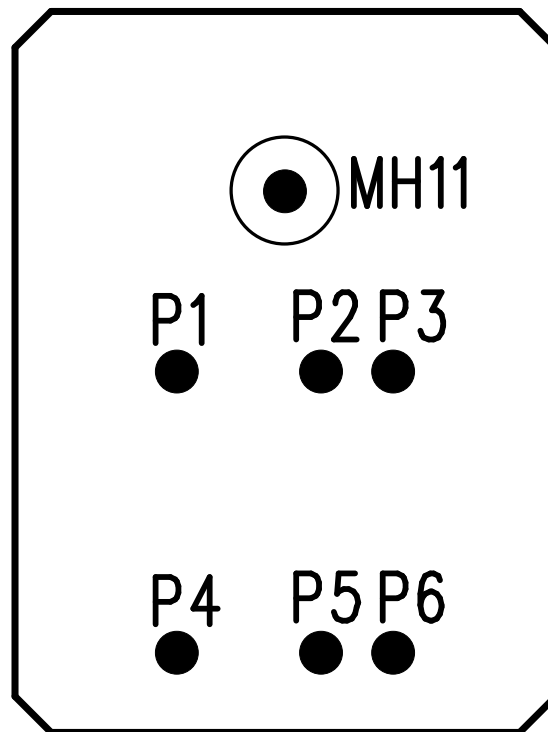

**SSP-75**

**TESTING  
PROCEDURES**

- 1-check all wires and components
- 2-Check screws and bolts
- 3-Connect the jumpers for 120 Volts
- 4-Turn the bias all the way to 0 volts
- 5-Connect the unit in bypass mode
- 6-Connect the unit with variable transformer
- 7-Connect speaker cables, regular and balanced inputs
- 8-Apply 10V AC from variable transformer and check the rail and driver voltages
- 9-If the unit is OK increase the voltage up to 120V
- 10-Turn off the unit and remove by pass
- 11-Turn on the unit and check the rails driver and offset
- 12-Check the sequence of relay clicking
- 13-Adjust the bias and offset
- 14-Check the protection circuit both channels
- 15-Check the signal with 8 and 4 load in
- 16-Regular, regular mono, balanced stereo and balanced mono
- 17-Check noise with small speaker and RCA shorted plug
- 18-Put in burning bench

1. Before final test unit was 4 days on burn-in-bench with music.
2. Take the unit from burn-in-bench to Q.C and play it immediately. Keep the line 120V A.C.
3. Check physically and check the components.
  - check all capacitor and devices direction. Capacitor stand up right way i.e. check co-solder.
  - check any missing parts.
  - check all fuse sockets.
  - check main board tight up with screw and washer.
  - check any screw missing.
  - check balance lock working smoothly.
  - check all output transistors position with pad.
  - check main transistors position with pad.
  - check main transformer tight very well.
4. Adjust bias 26mV for every output devices for both channels. Wait 7 to 8 minutes after each adjustment. Also adjust offset to 0mV.
5. Measure rail and pre-driver voltage.
6. Measure A.C voltage for bridge.
7. Measure supply voltage for relays. +15V and 15V for both channels. +12V and 12V.
8. Measure reference voltage 8.1V on both channels.
9. Measure reference voltage for protection 78V.
10. After setting the bias, connect load and input signal. Check output signal. Check phase with input signal.
11. Measure frequency response, slew rate, gain, signal to noise ratio.
12. Check the output signal from 20Hz to 20KH with load in following combination. Also measure the output power.
  - Regegur-stereo
  - Balance-stereo
  - Regegur-mono
  - Balance-mono
13. Check phone-jack.
14. Check protection on both channels.
15. Check noise with speaker.
16. Put the jumpers and varistor for required A.C voltage.
17. Plug unit again and check rail and pre-driver voltage.

**SSP-75**

**DIAGRAMS**

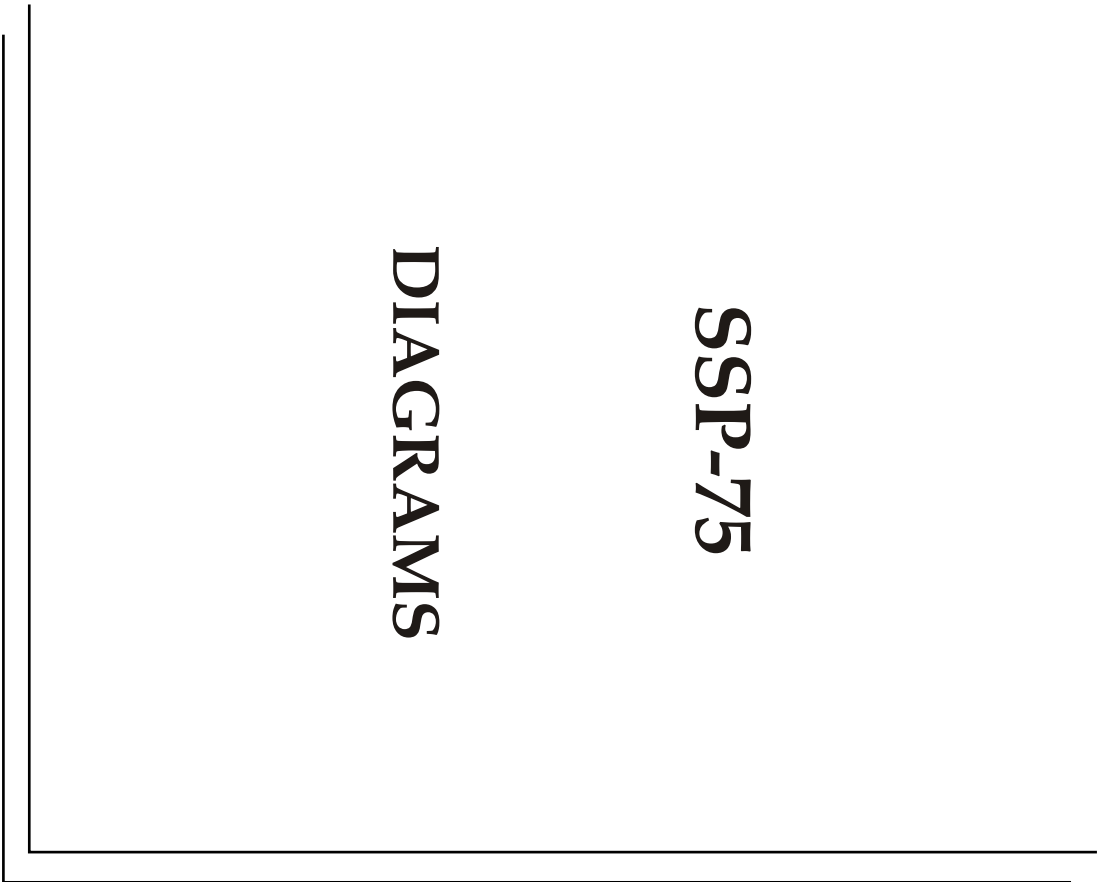

# POWER SUPPLY

SSP-75

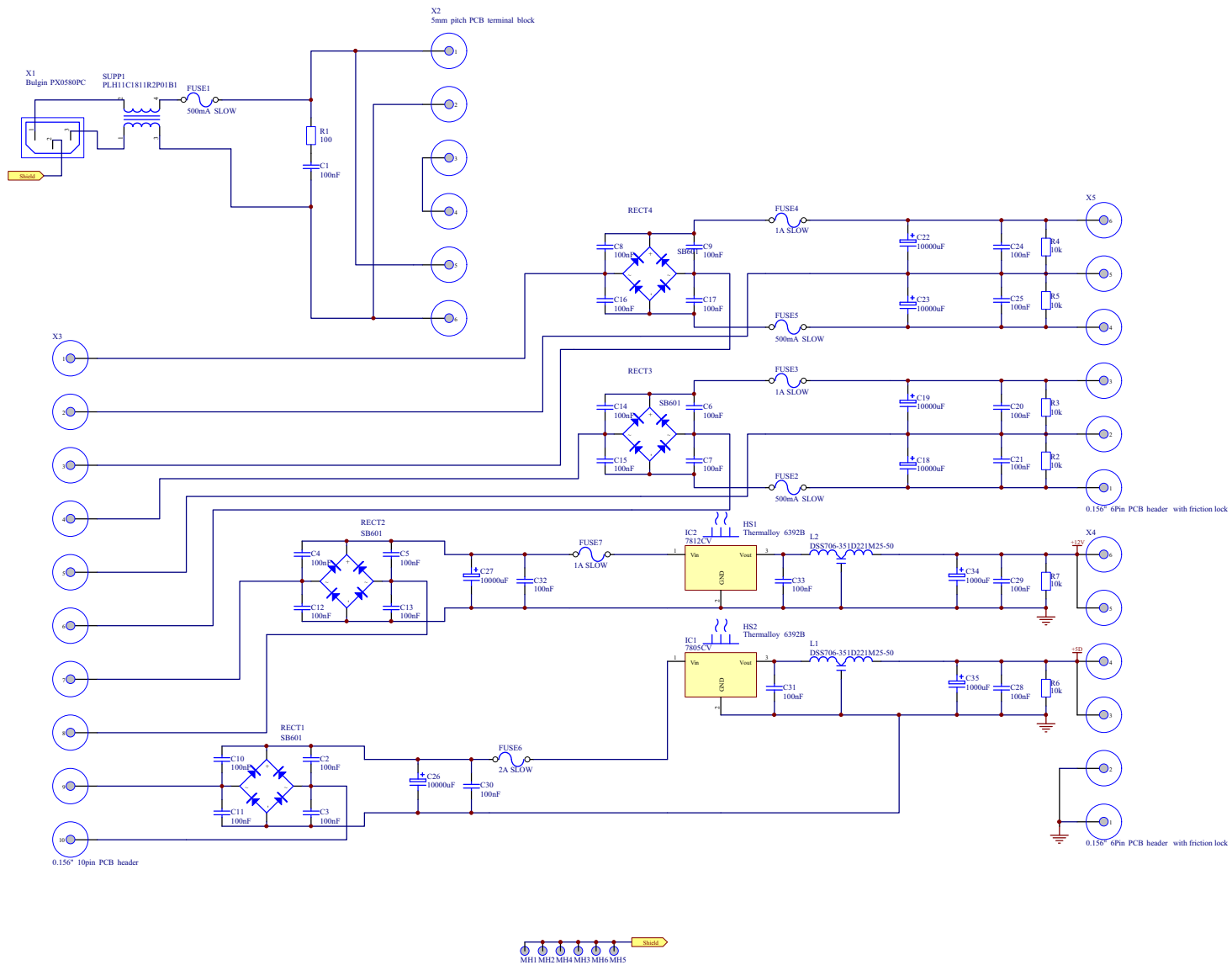

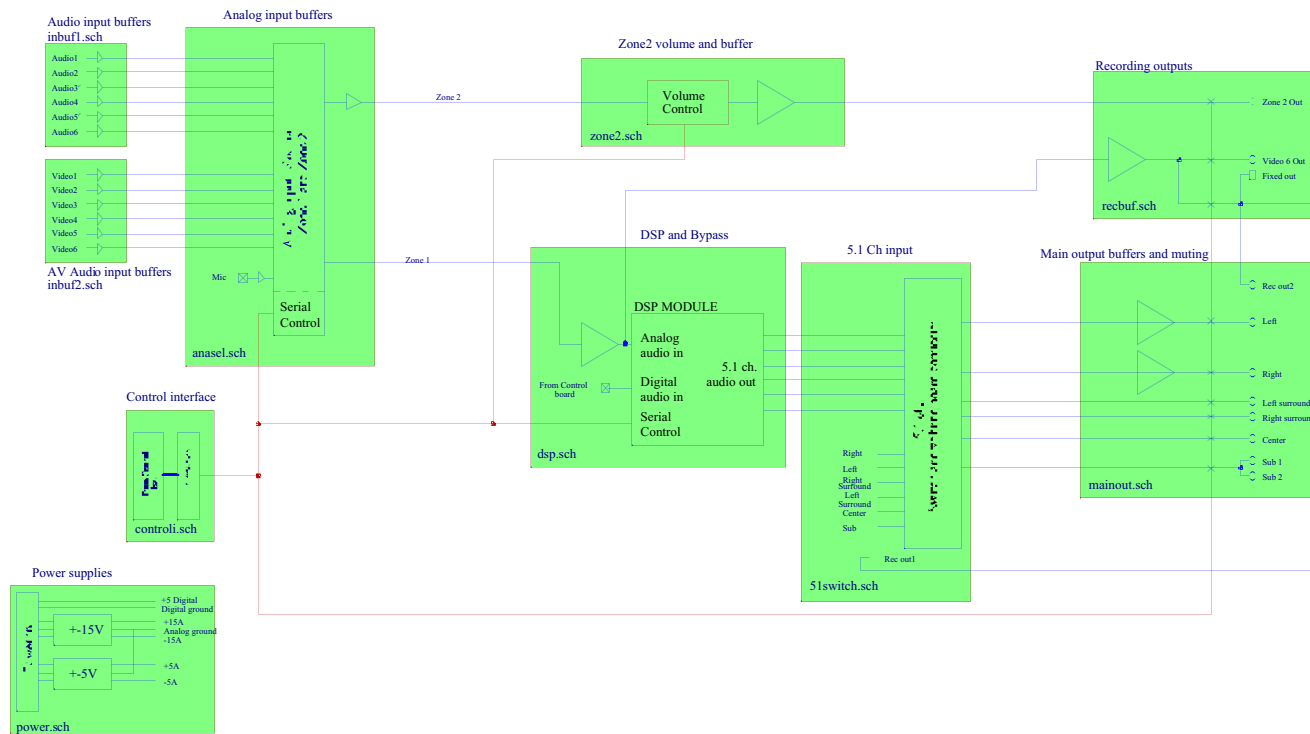

# 5.1 CHANNEL

SSP-75

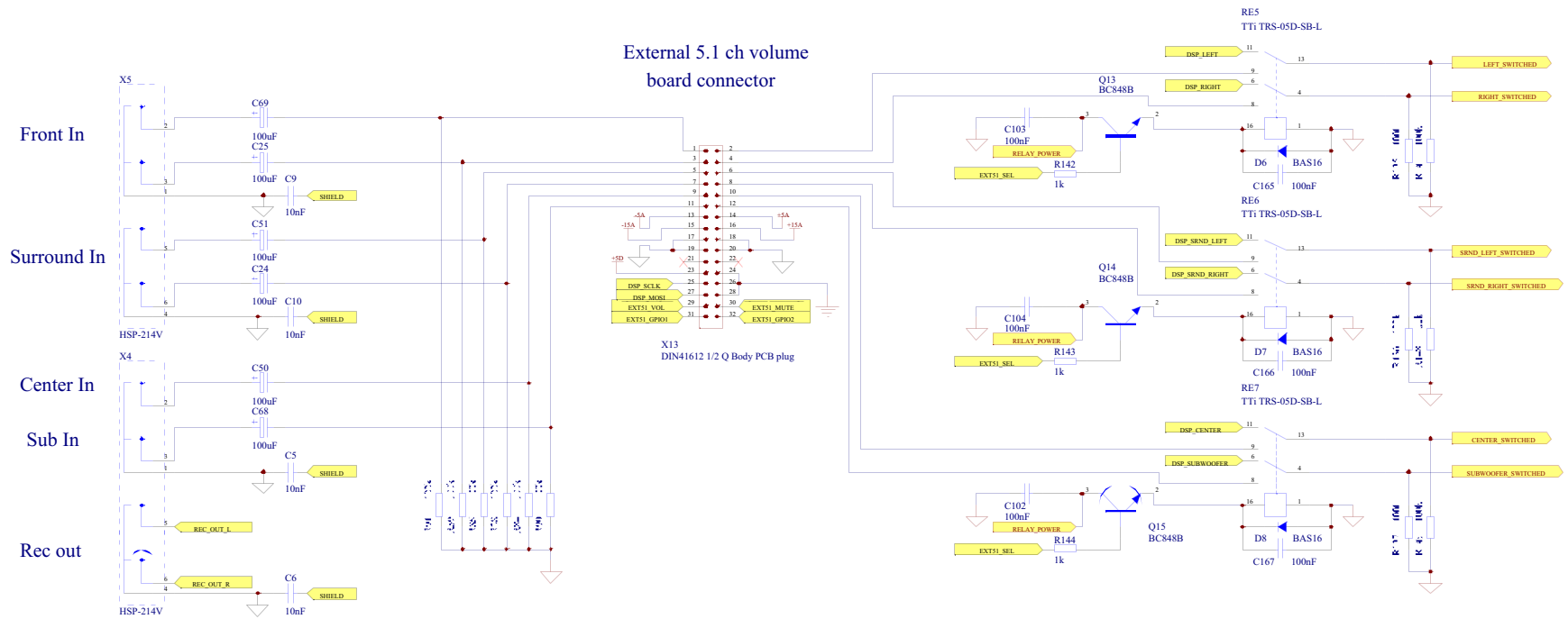



# CONTROL INTERFACE

SSP-75

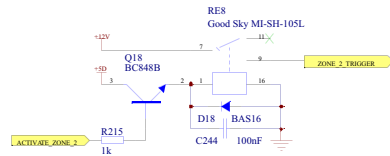
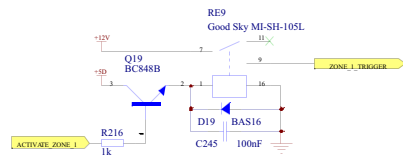

Analog power connector

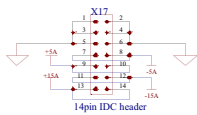

Controlboard connector

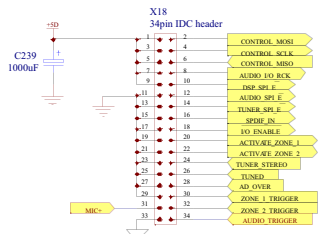

Tuner connector

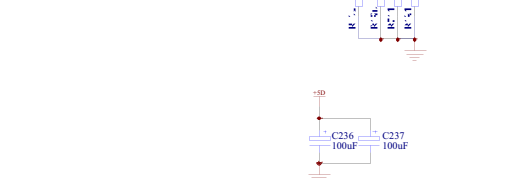
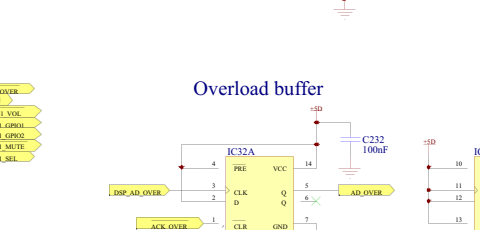
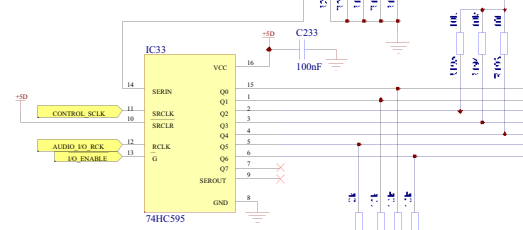
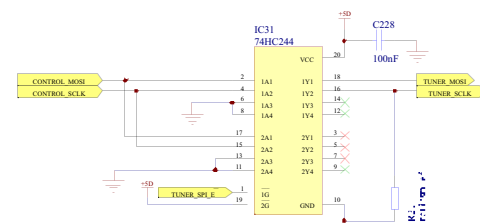
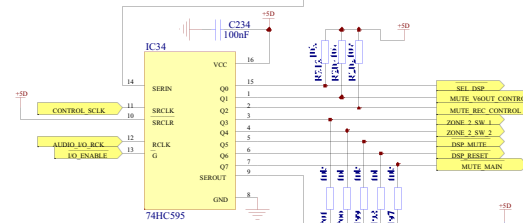
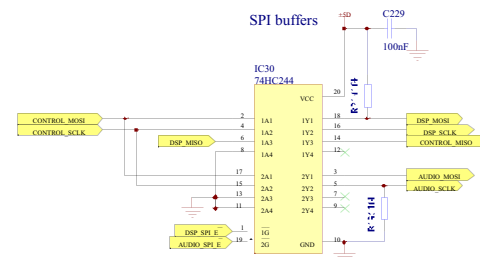
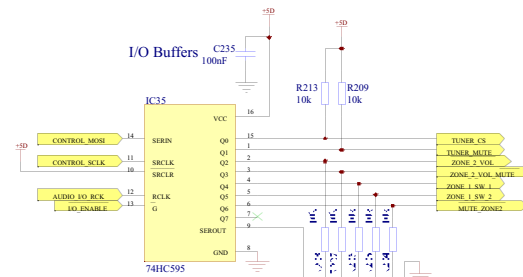
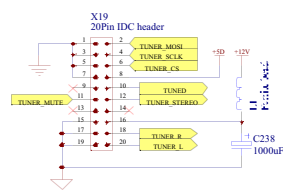

# RECORDING OUTPUT BUFFERS & MUTING

SSP-75

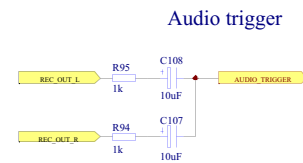
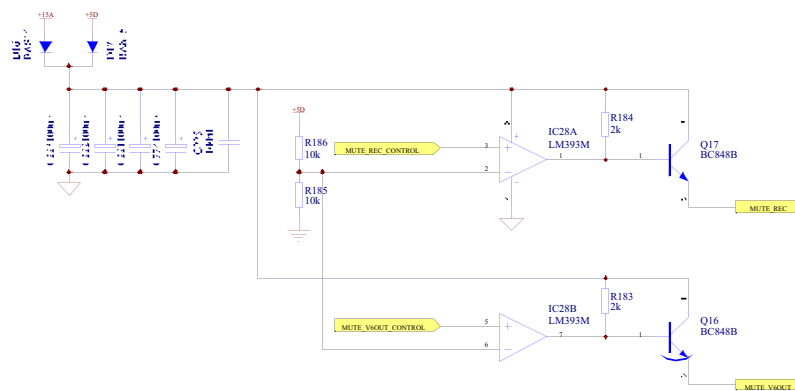
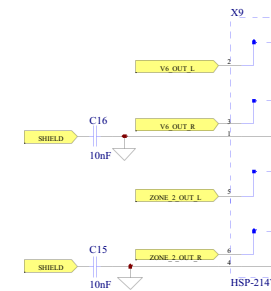
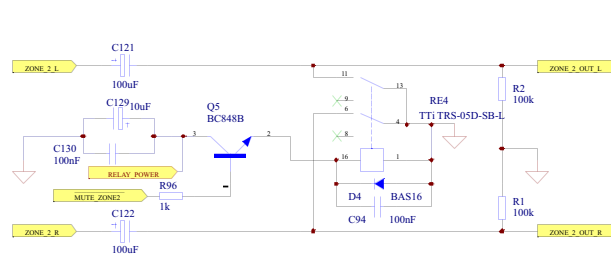
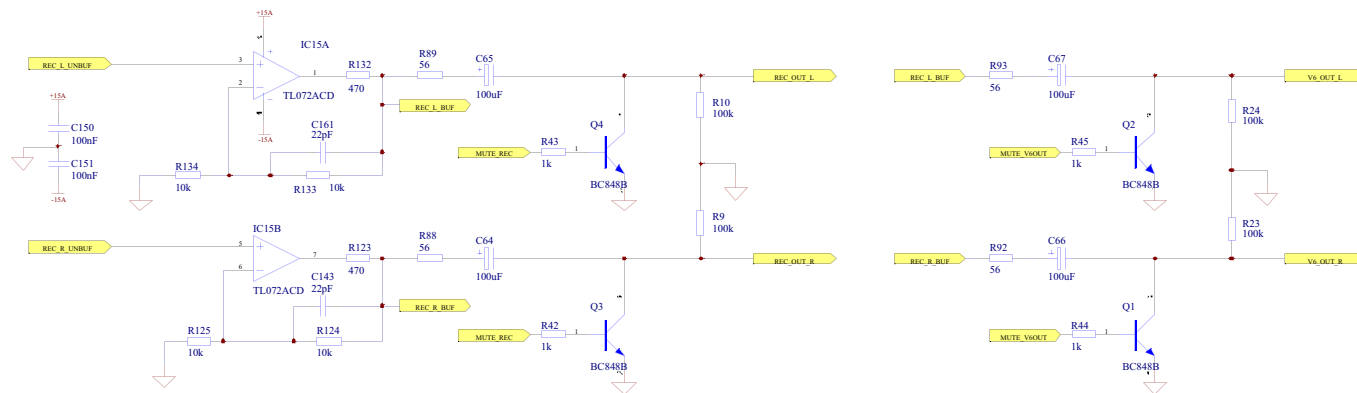

# VIDEO ANALOG INPUT BUFFERS

SSP-75

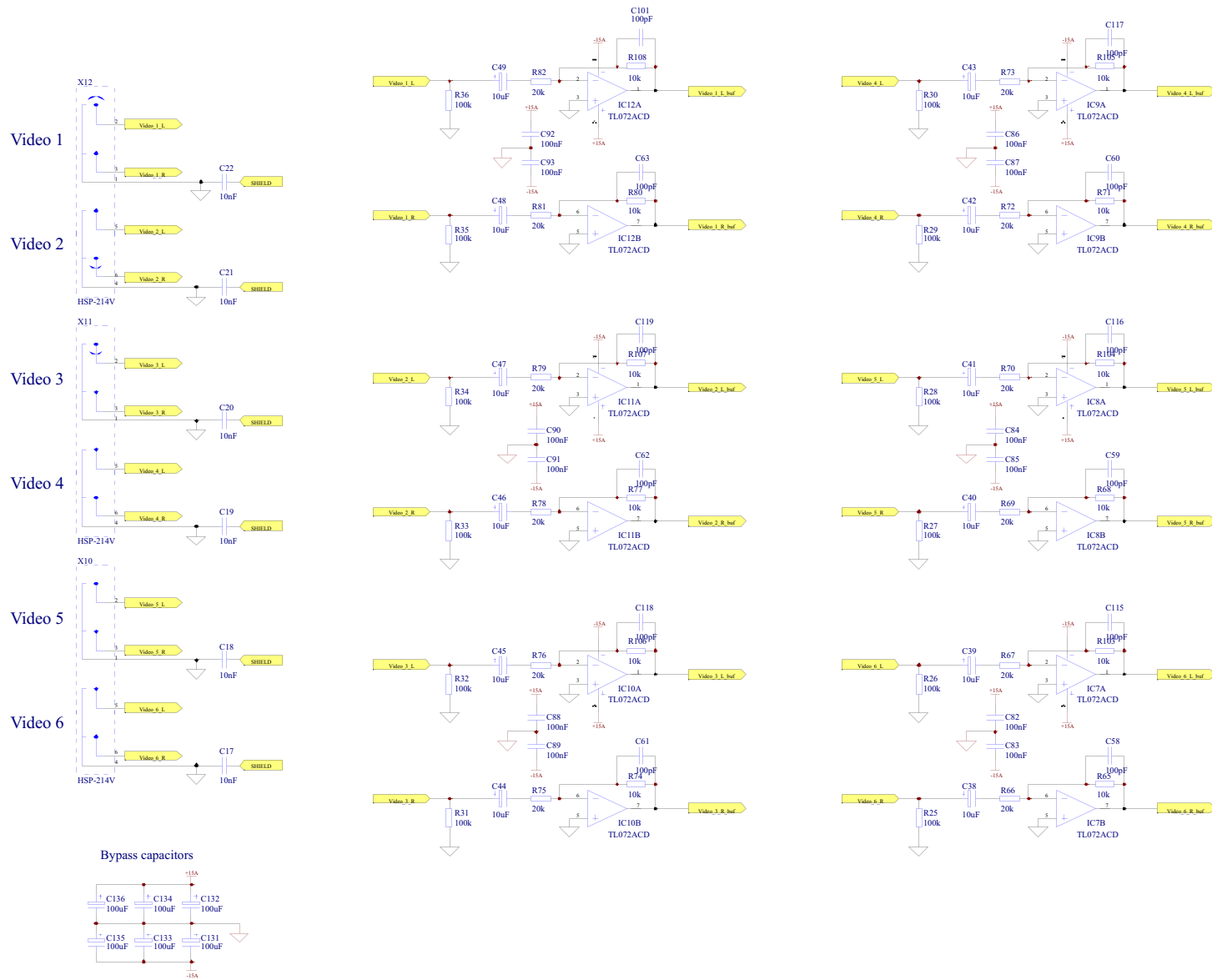

# AUDIO ANALOG INPUT BUFFERS

SSP-75

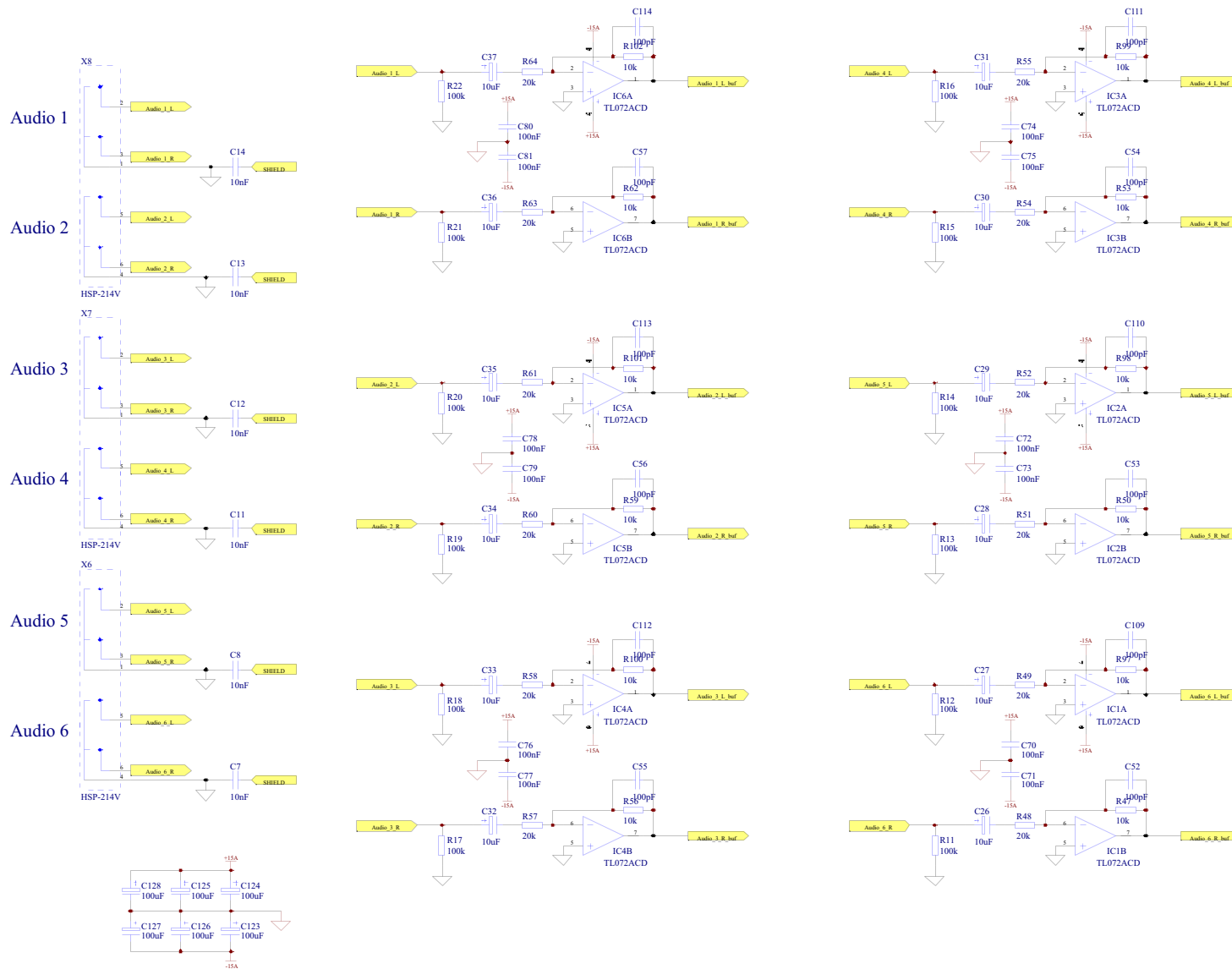

# ZONE 2 VOLUME & BUFFER

SSP-75

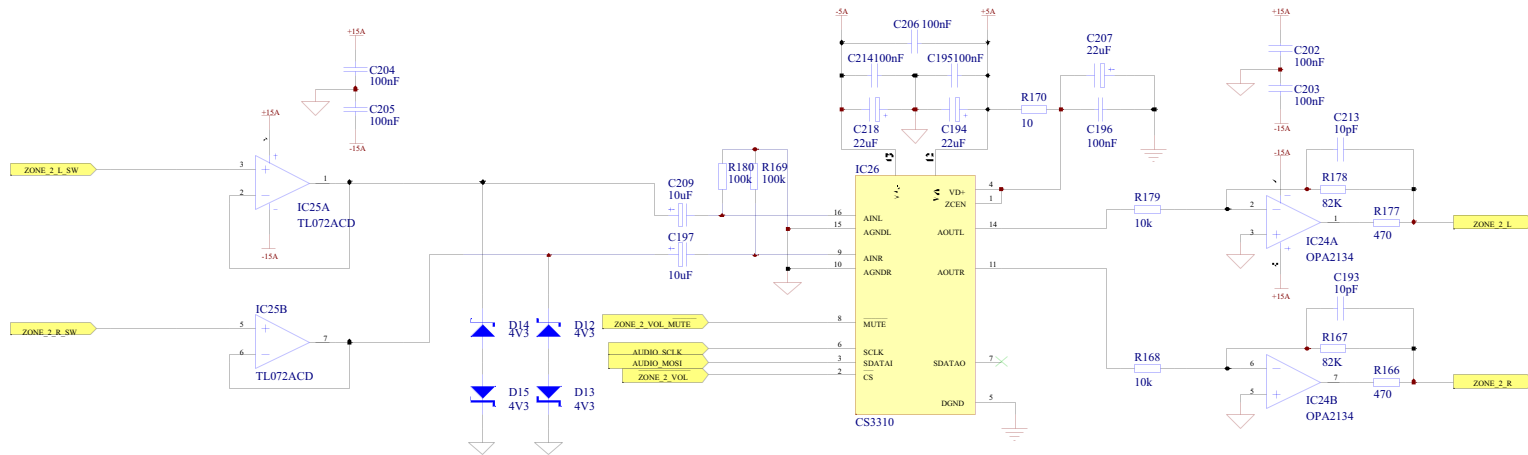

Zone 1 selectors

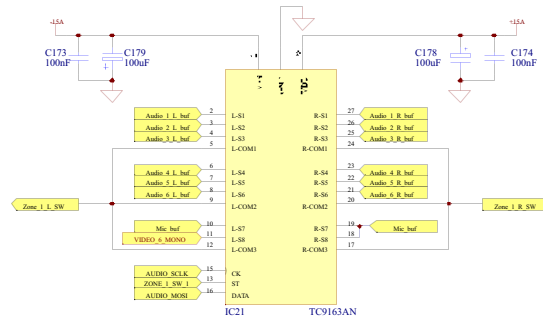

Zone 2 selectors

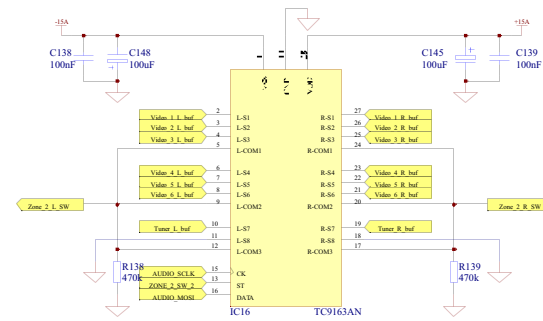
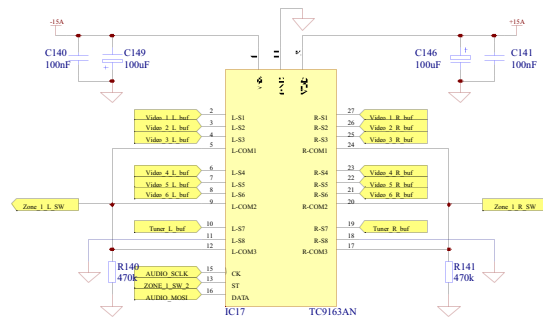
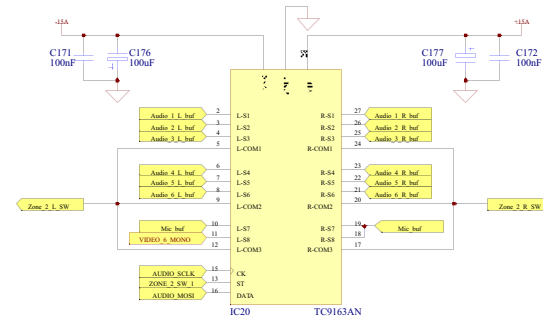

Microphone buffer

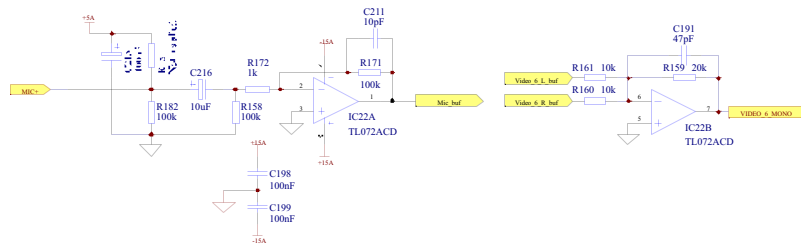

Tuner buffers

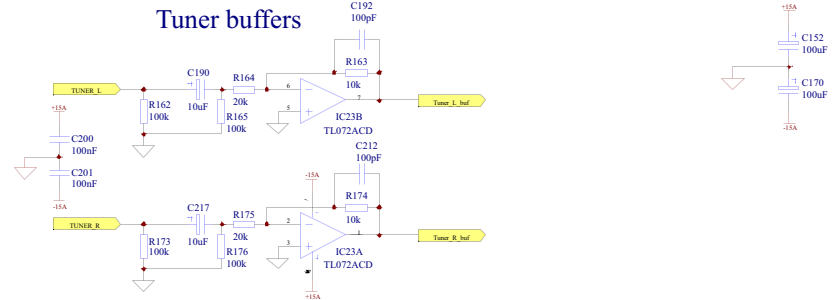

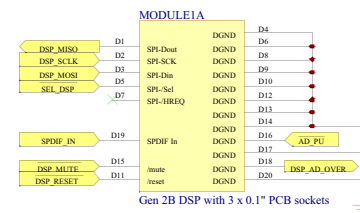
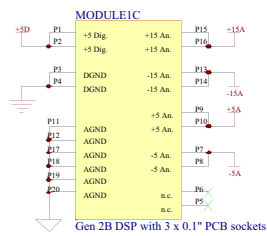
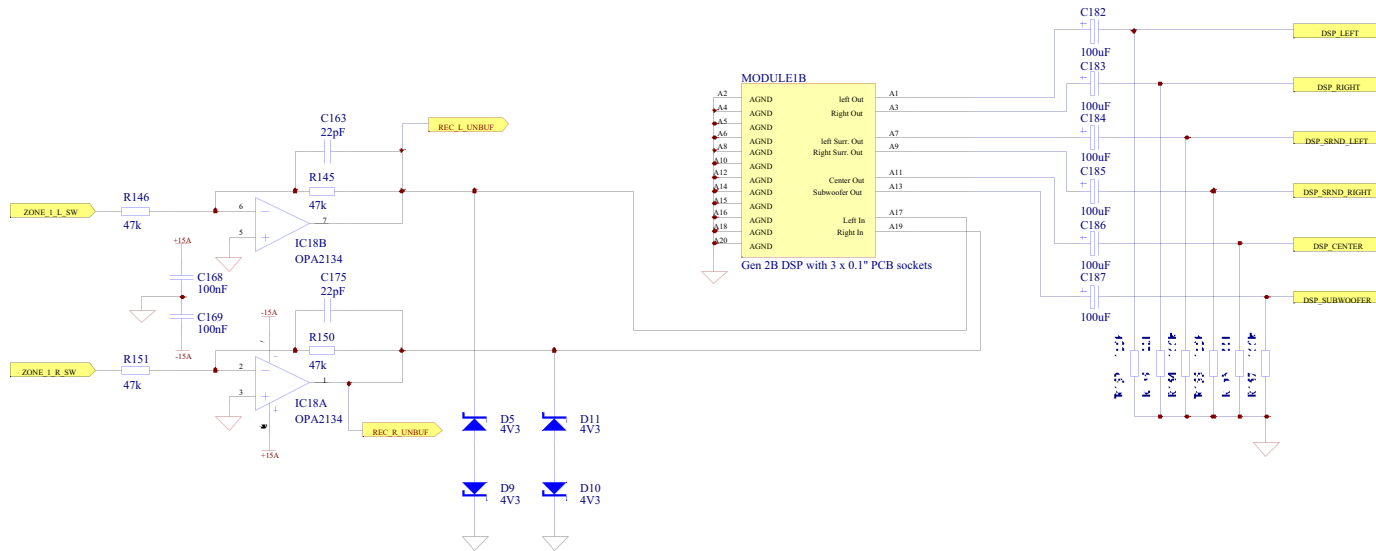

# 5.1 CHANNEL OUTPUT

SSP-75

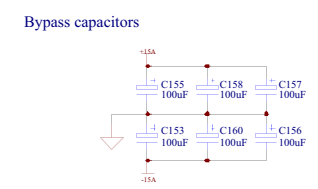
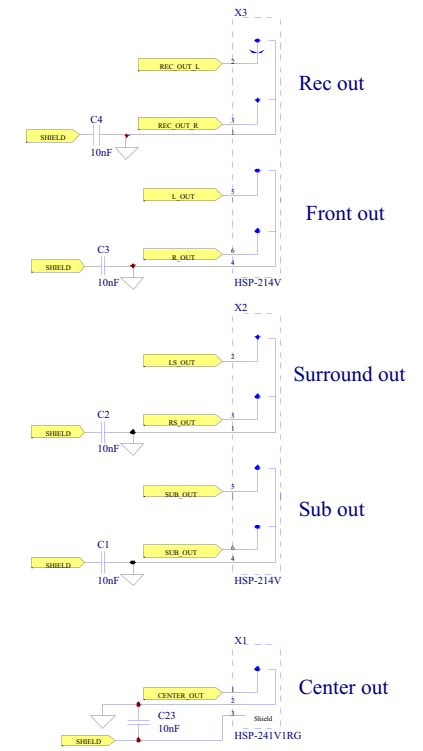
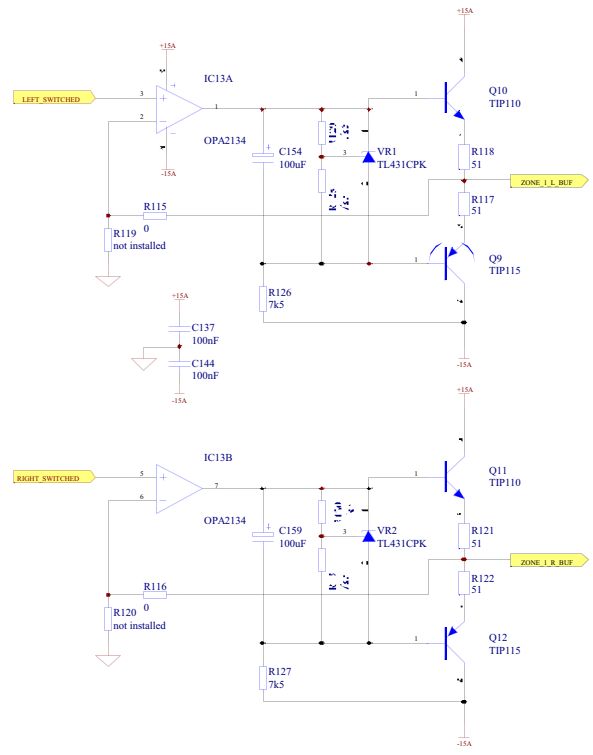
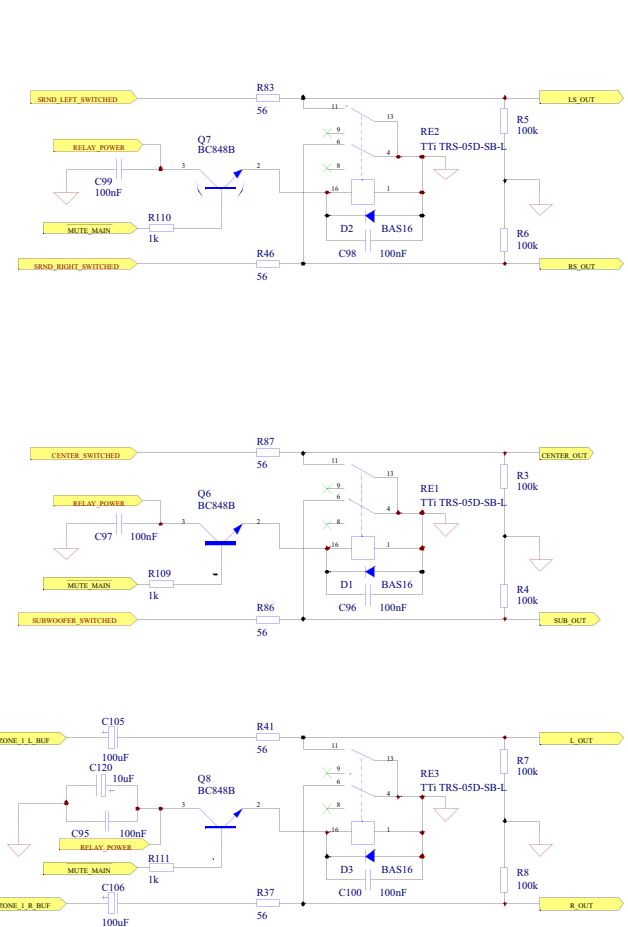



### Power connectors

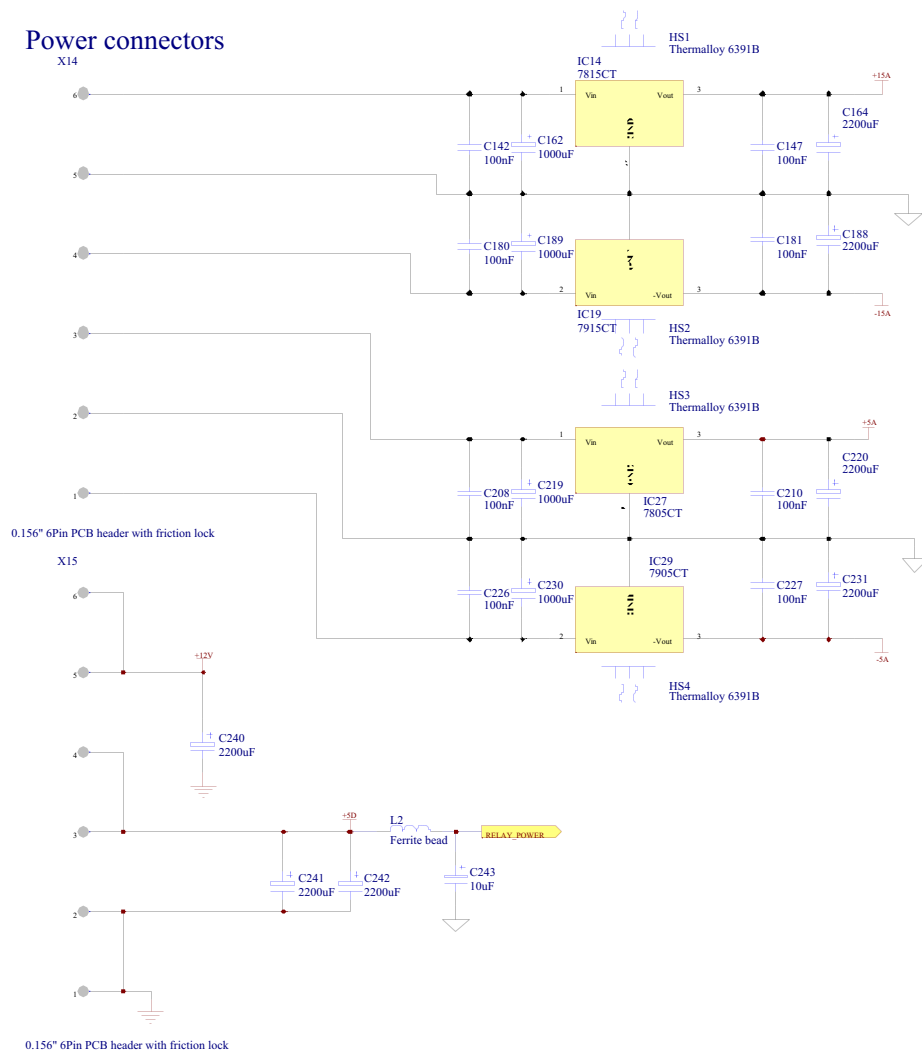

### Scope hooks

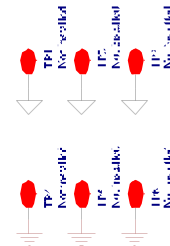

### Ground connects

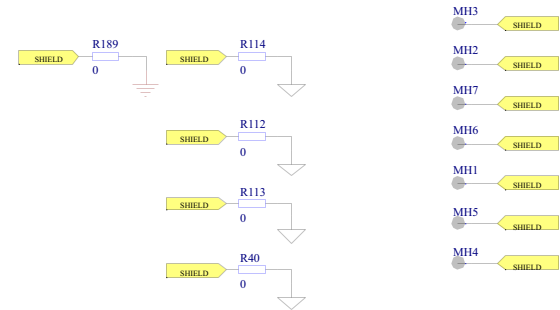
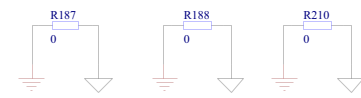

Led

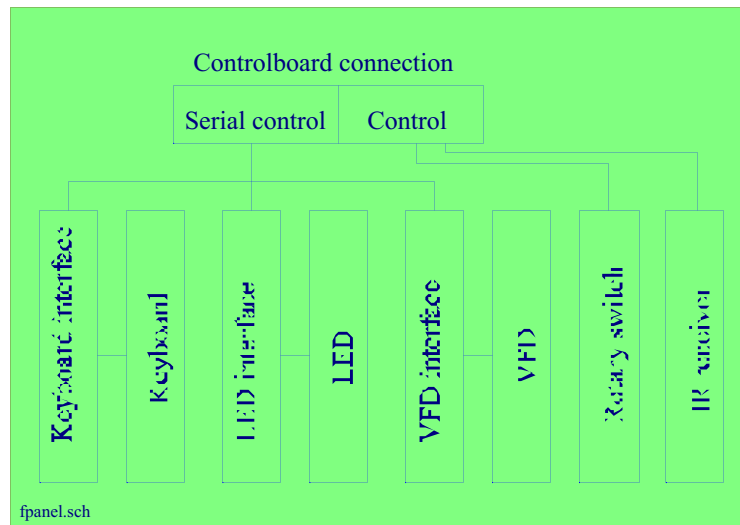

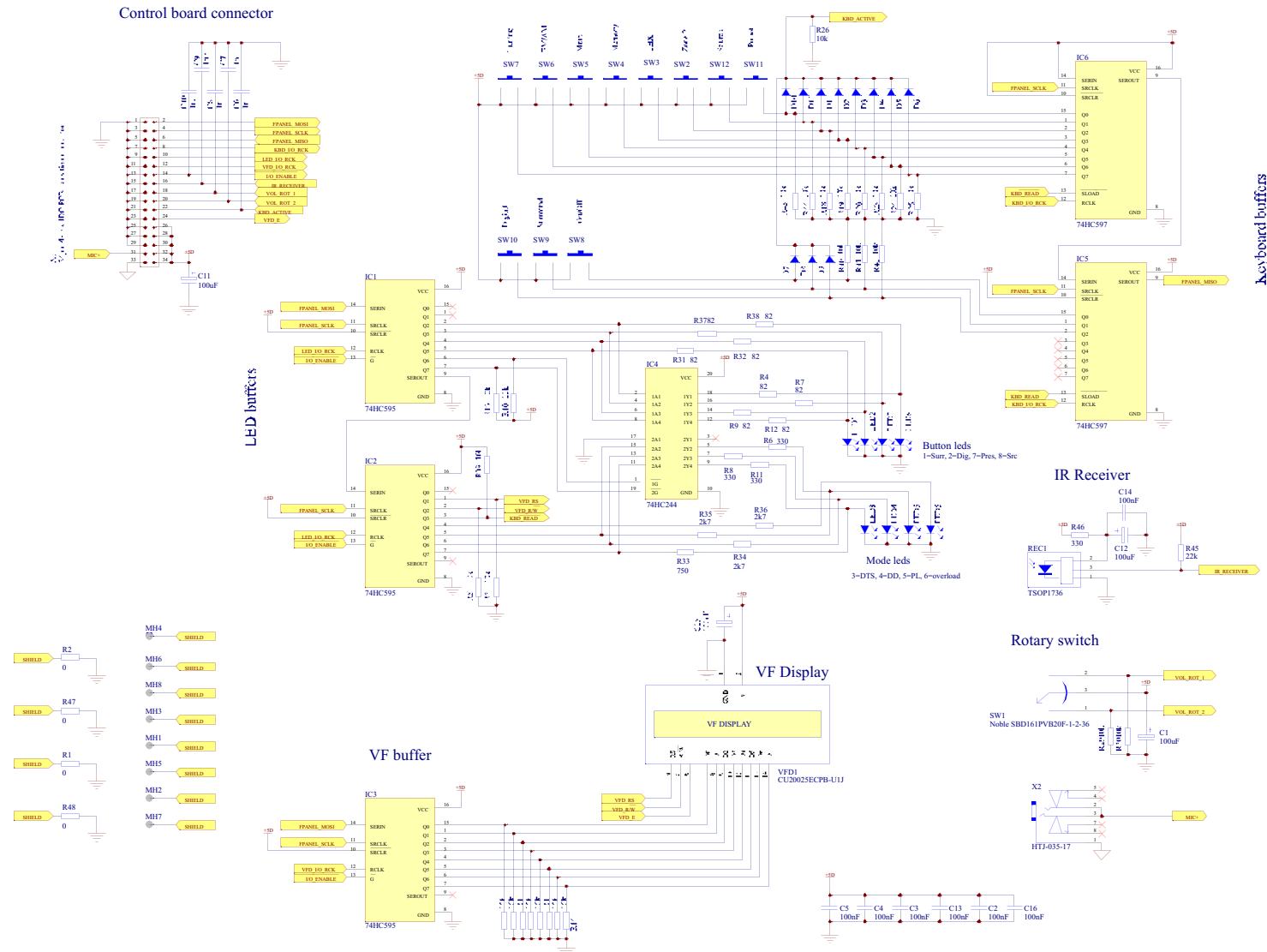

Control board connector

LED buffers

Keyboard buffers

IR Receiver

Rotary switch

VF Display

VF buffer

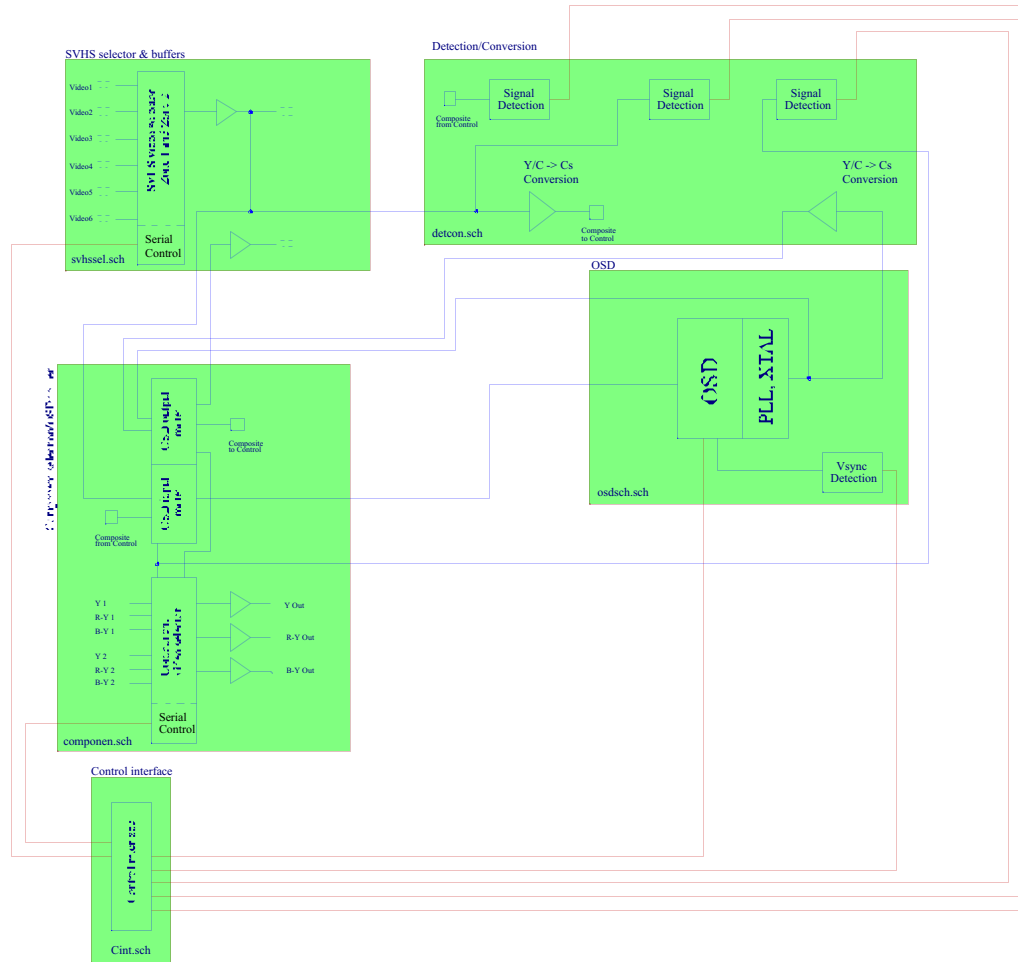

### Video signal presence detection

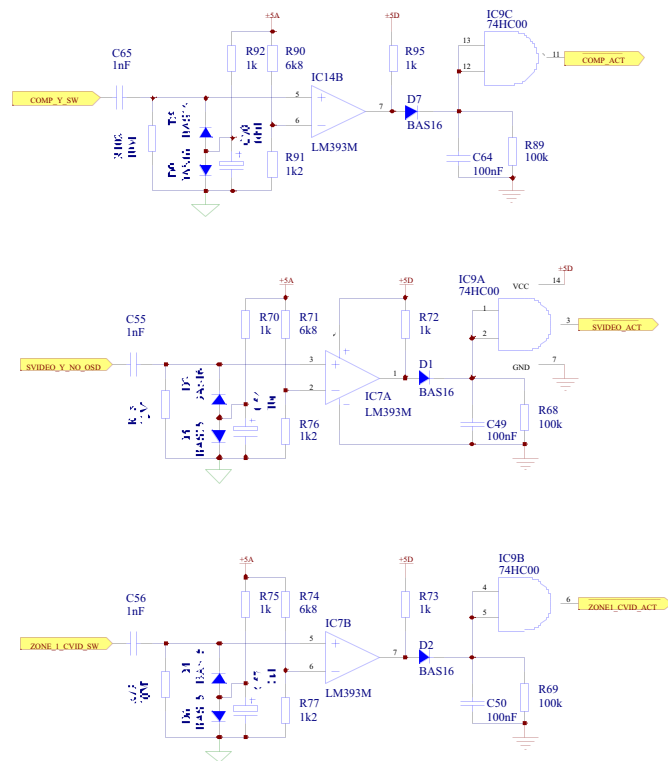

### Y/C -> Composite conversion

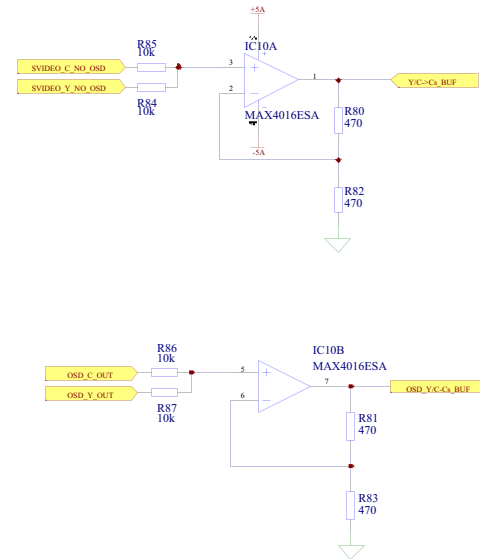

### Bypass capacitors

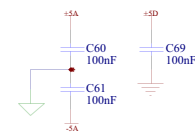

Controlboard composite video connector

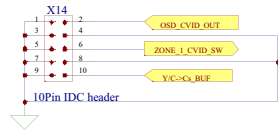

Controlboard I/O connector

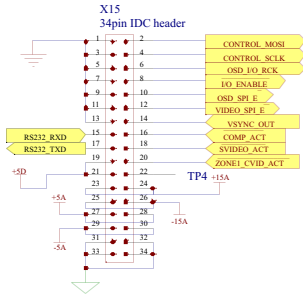

Power supply filtering

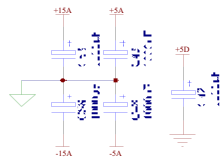

Bypass capacitors

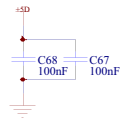

Serial I/O interface

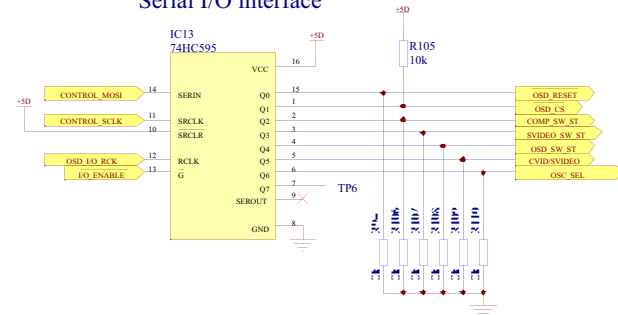

SPI buffer

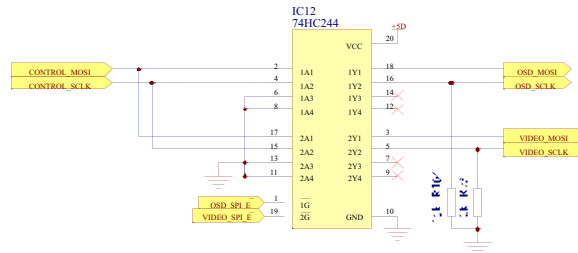

RS232 Connector

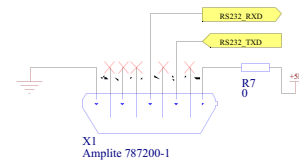

### SVideo Input connectors

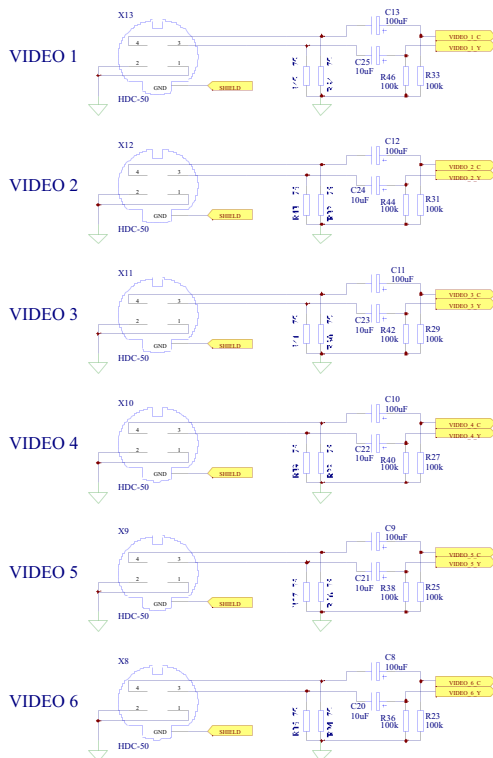

### Video6 SVideo Output connector

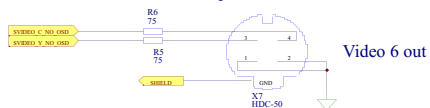

### SVideo selector

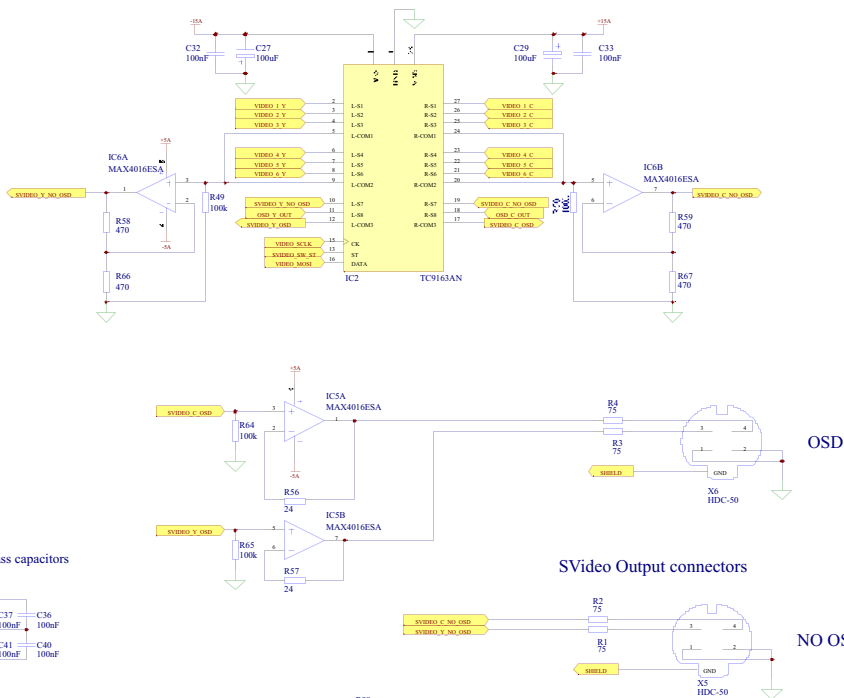

### Bypass capacitors

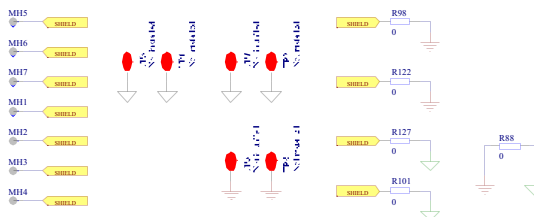
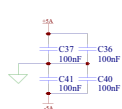

### SVideo Output connectors

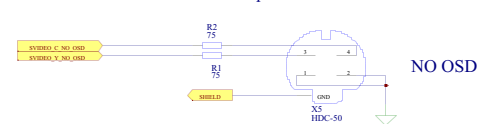

Component video input connectors

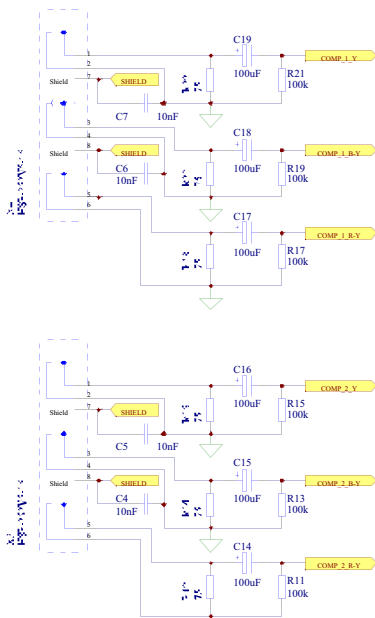

OSD router

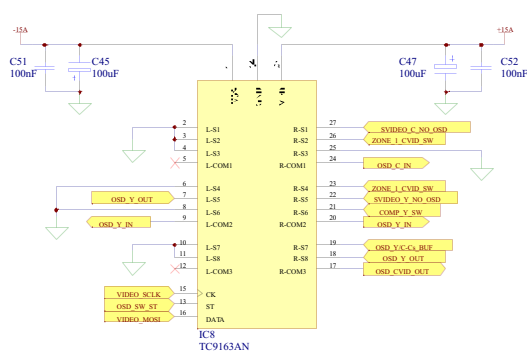

Component video output connectors

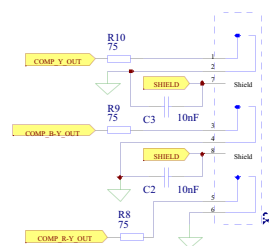

Bypass capacitors

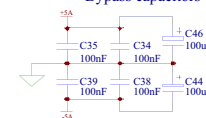

Component video selector

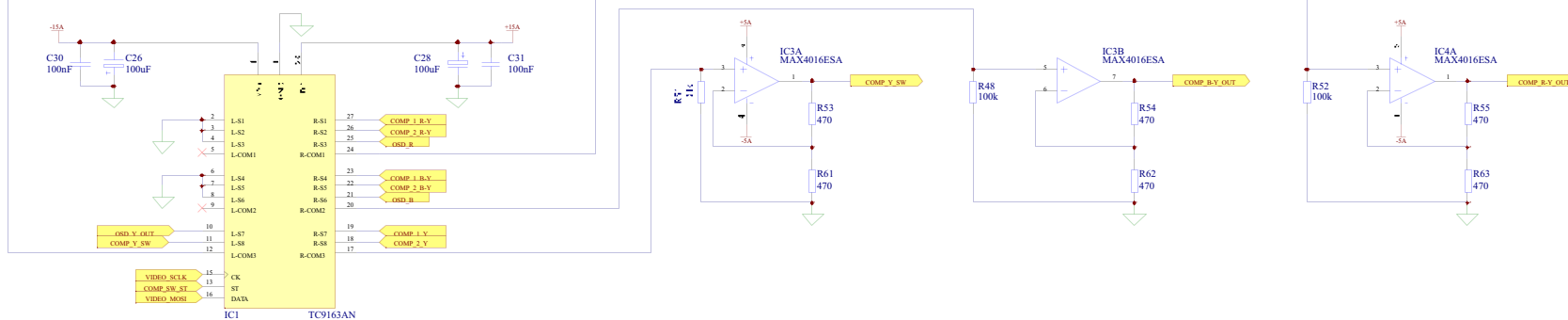



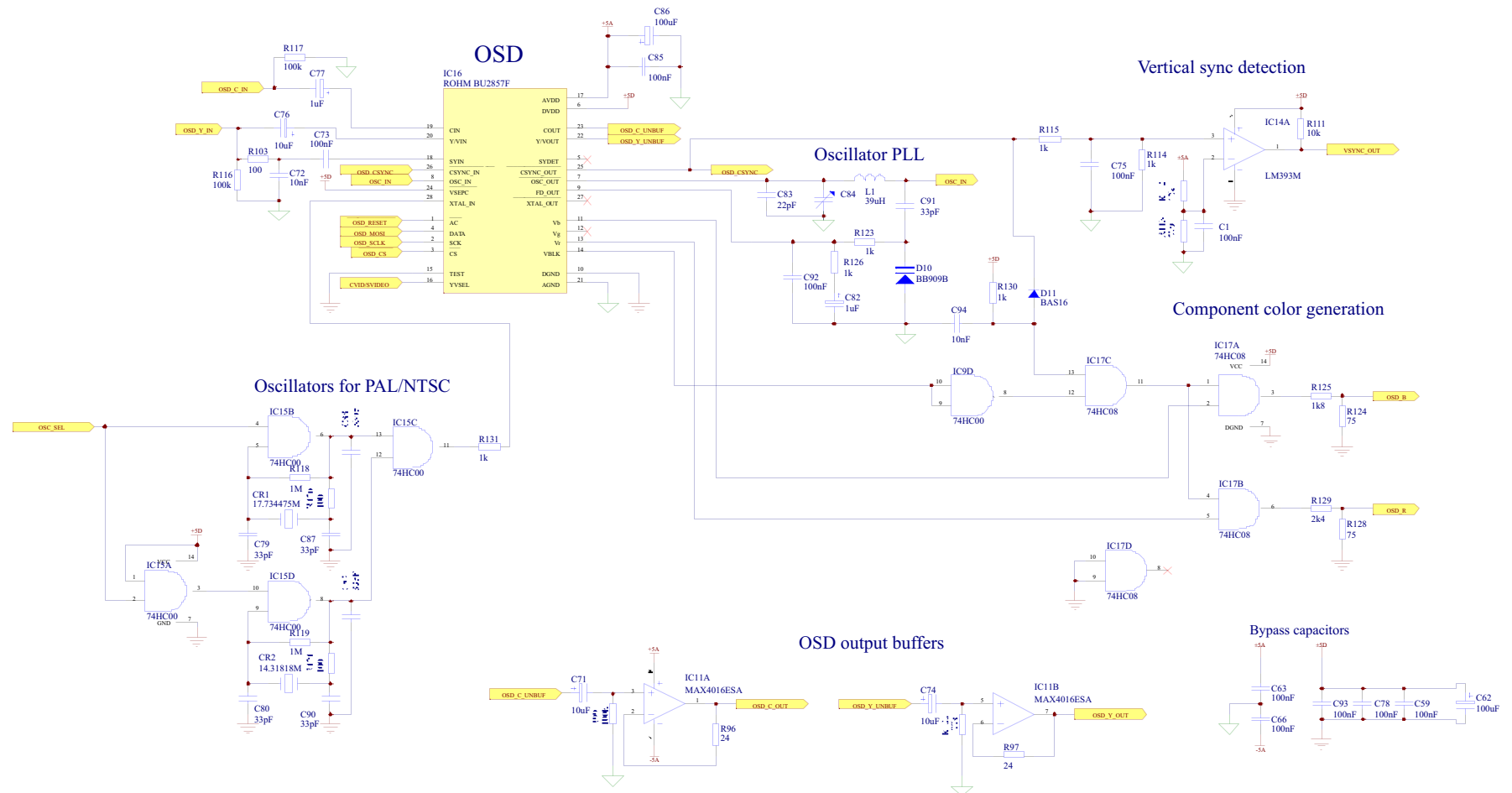

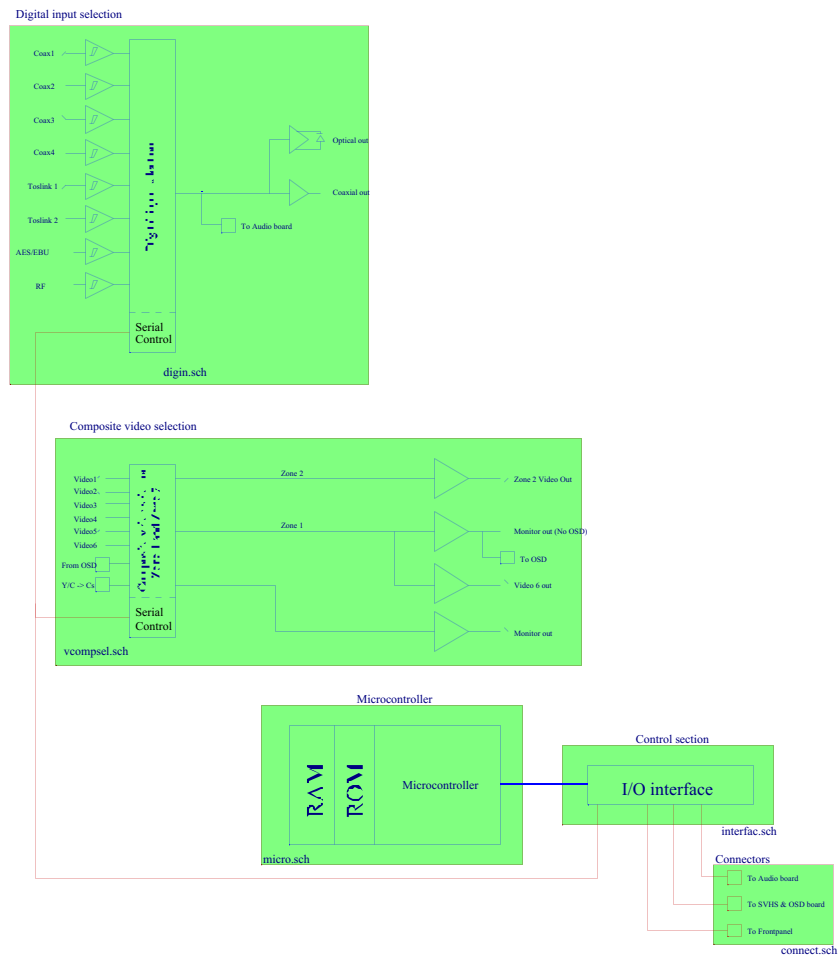



Coaxial 1

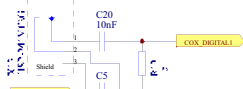

Coaxial 2



Coaxial 3



Coaxial 4

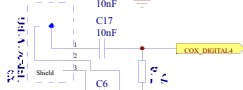

AES/EBU

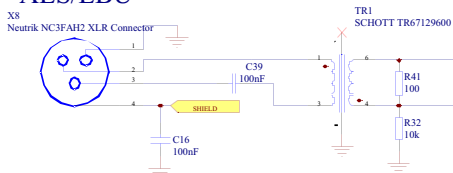

Optical 1

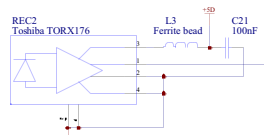

Optical 2

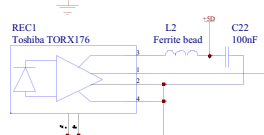

RF demodulator connector

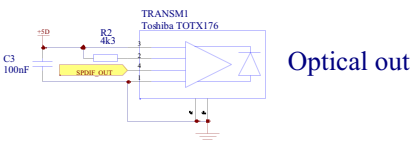
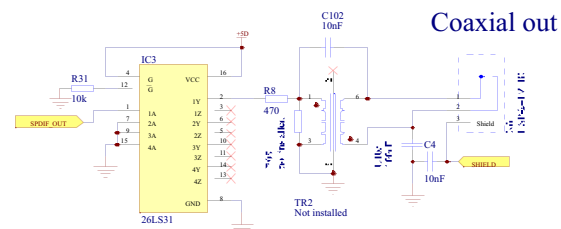
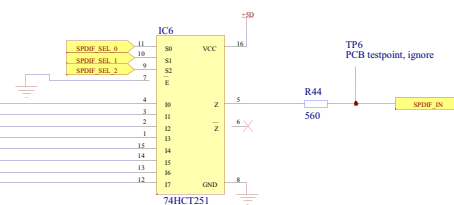
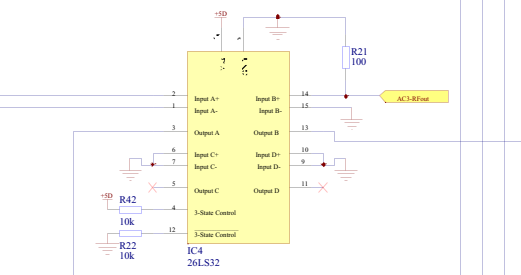
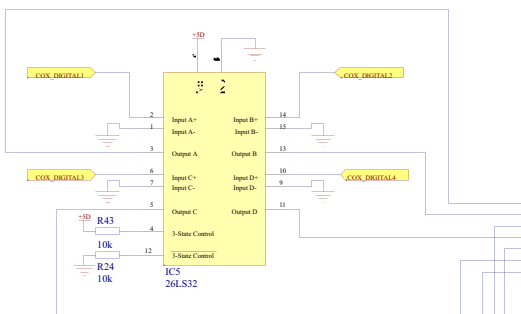
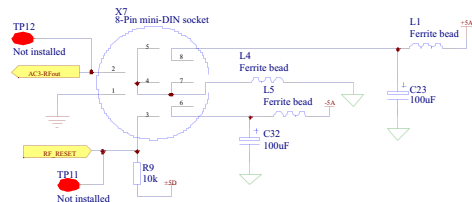

Bypass capacitors

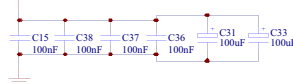

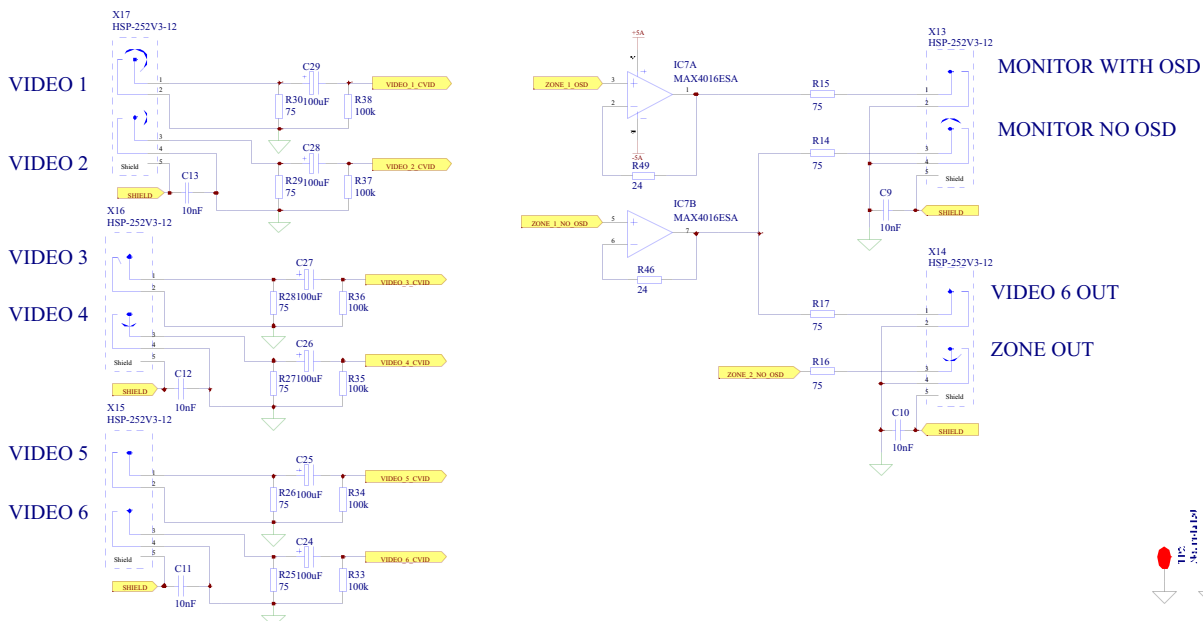

Zone 1 & 2 composite selector

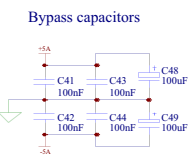
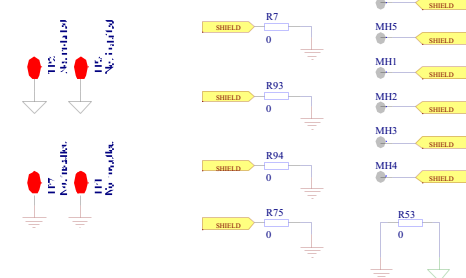
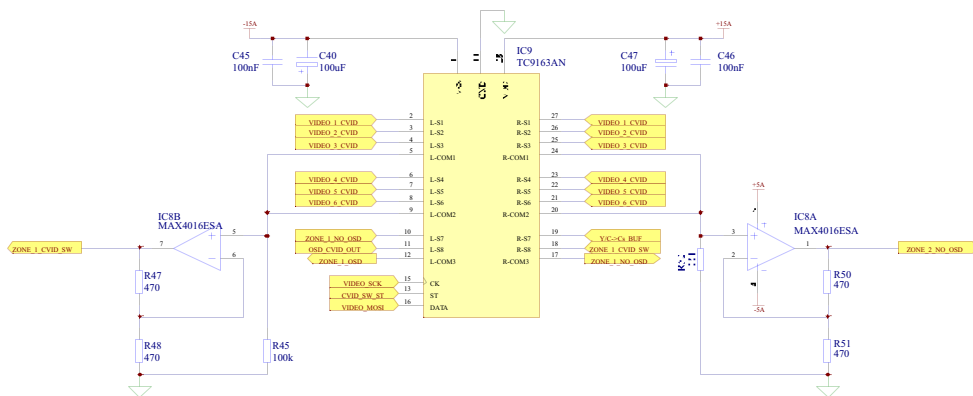



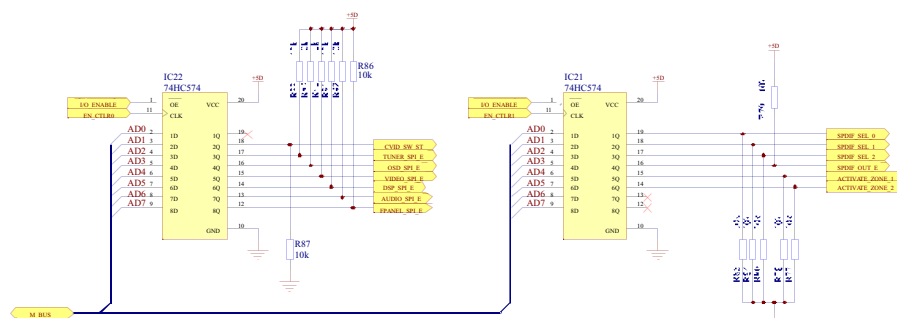

RS232 buffer

SPI buffer

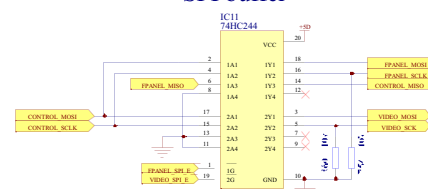
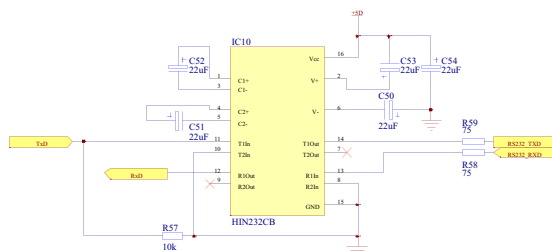

Zone 1 remote in

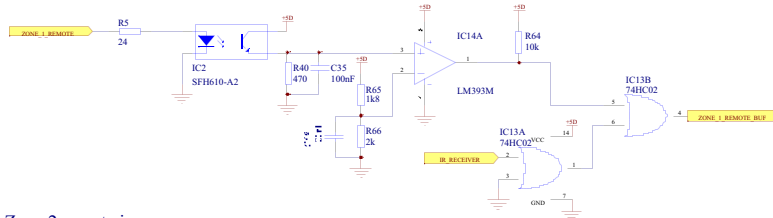

SPDIF buffer

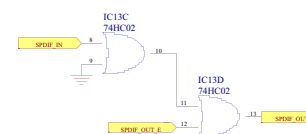

Zone 2 remote in

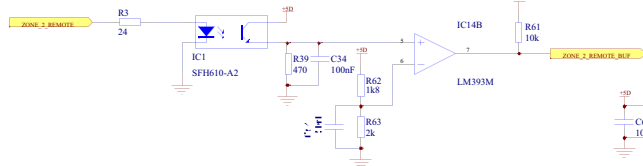

Bypass capacitors

