

COPLAND

VALVE AMPLIFIER

SERVICEMANUAL

FOR

CSA - 14

Bias adjustment for COPLAND CSA-14:

- 1.If the amplifier have been to service, for changing tubes or other parts in the outputstage, you should first turn the bias- potentiometers P 1 and P 101 fully in counter-clockwise direction.
- 2.Turn on the amplifier, and let it warm up for 1 minute.
- 3.Connect a voltmeter (on mV measuring range) across R 52 or R 53 (for left channel) and adjust with P1 for a reading of 5 mV.
- 4.For right channel, measure across R152 or R153, and adjust to 5 mV with P101.
- 5.Let the amplifier heat for 30 minutes, then please repeat 3. and 4.
- 6.If no parts have been canged in the outputstage of the amplifier the bias should already be close to the right value, so you can start bias-adjustment at point 2. (you don't need to do point 1.)

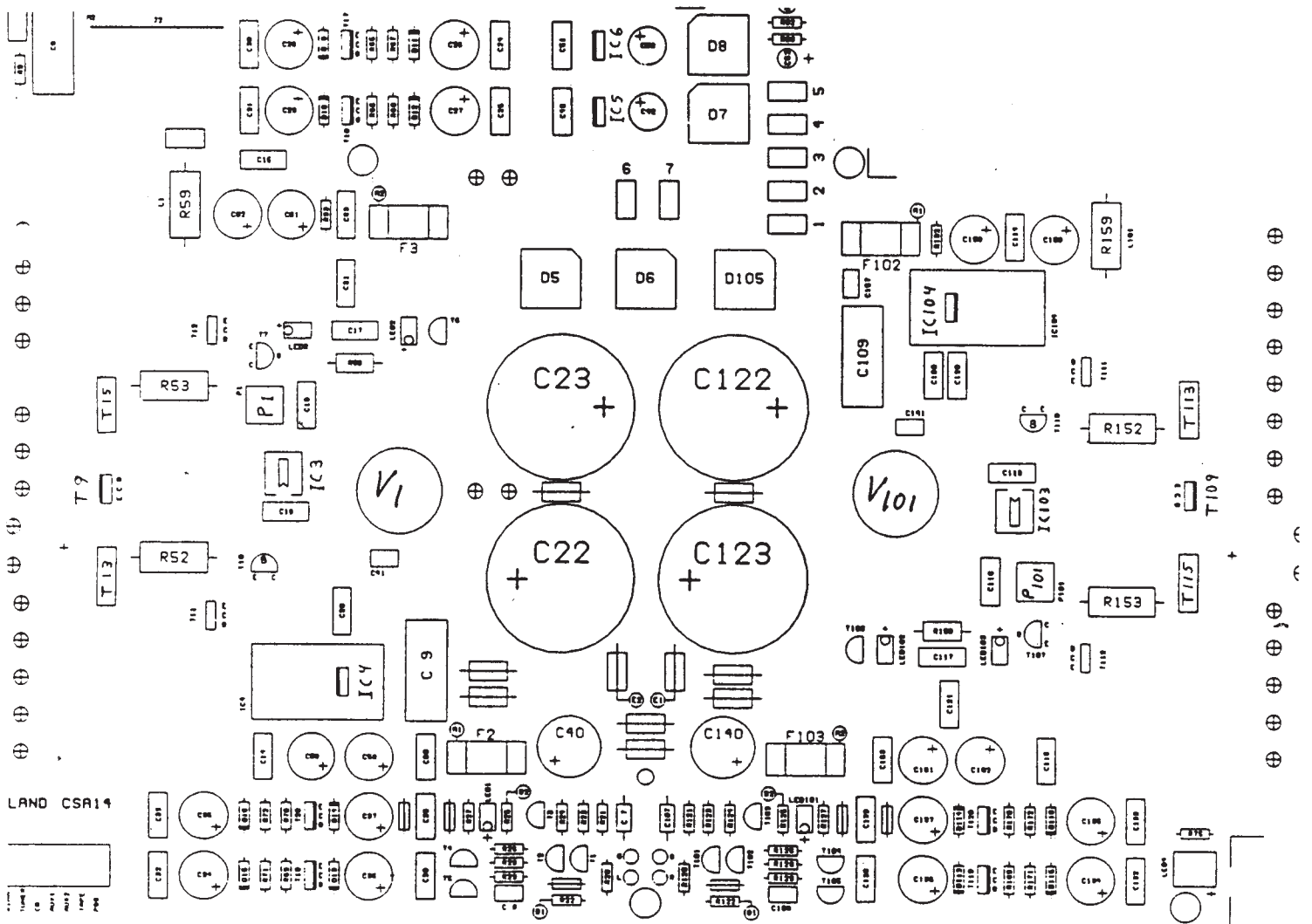

COPLAND	Type	CSA14	Schematic
			Page 1 of
Integrated Amp	No.	File: D14-B (A)	Date 4/2-95.

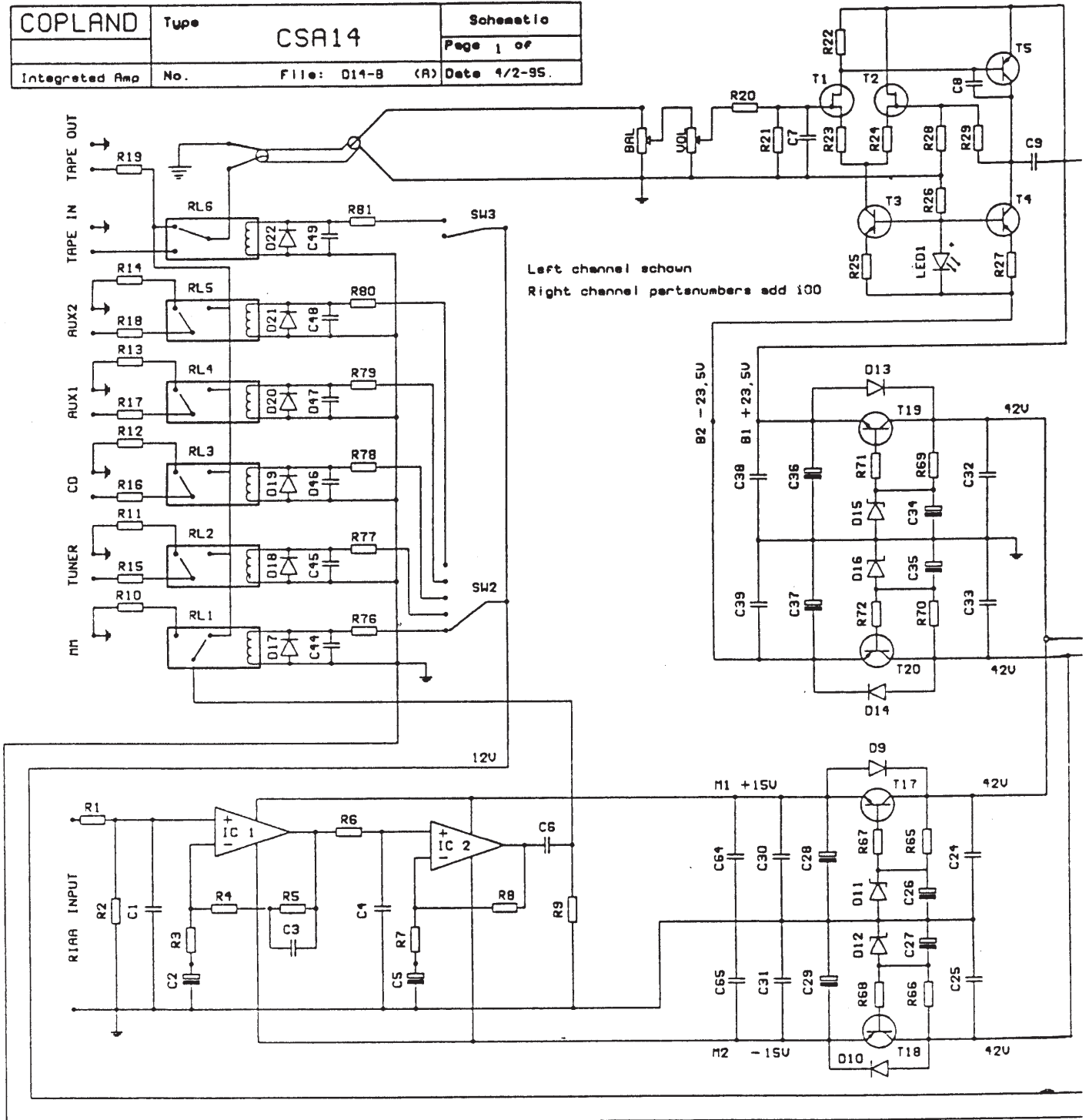

D14-R. SCH

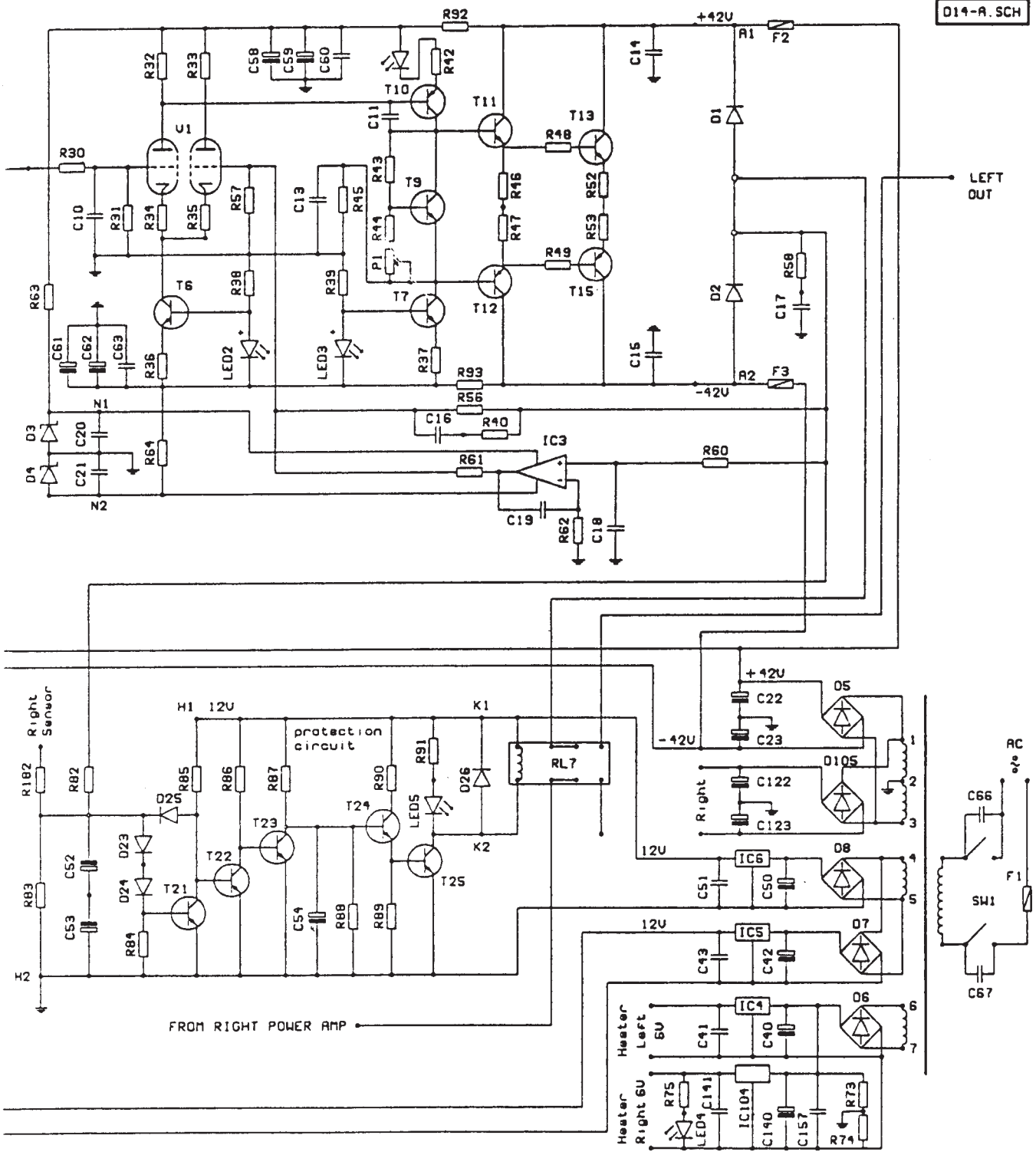

Main Board CSA 14

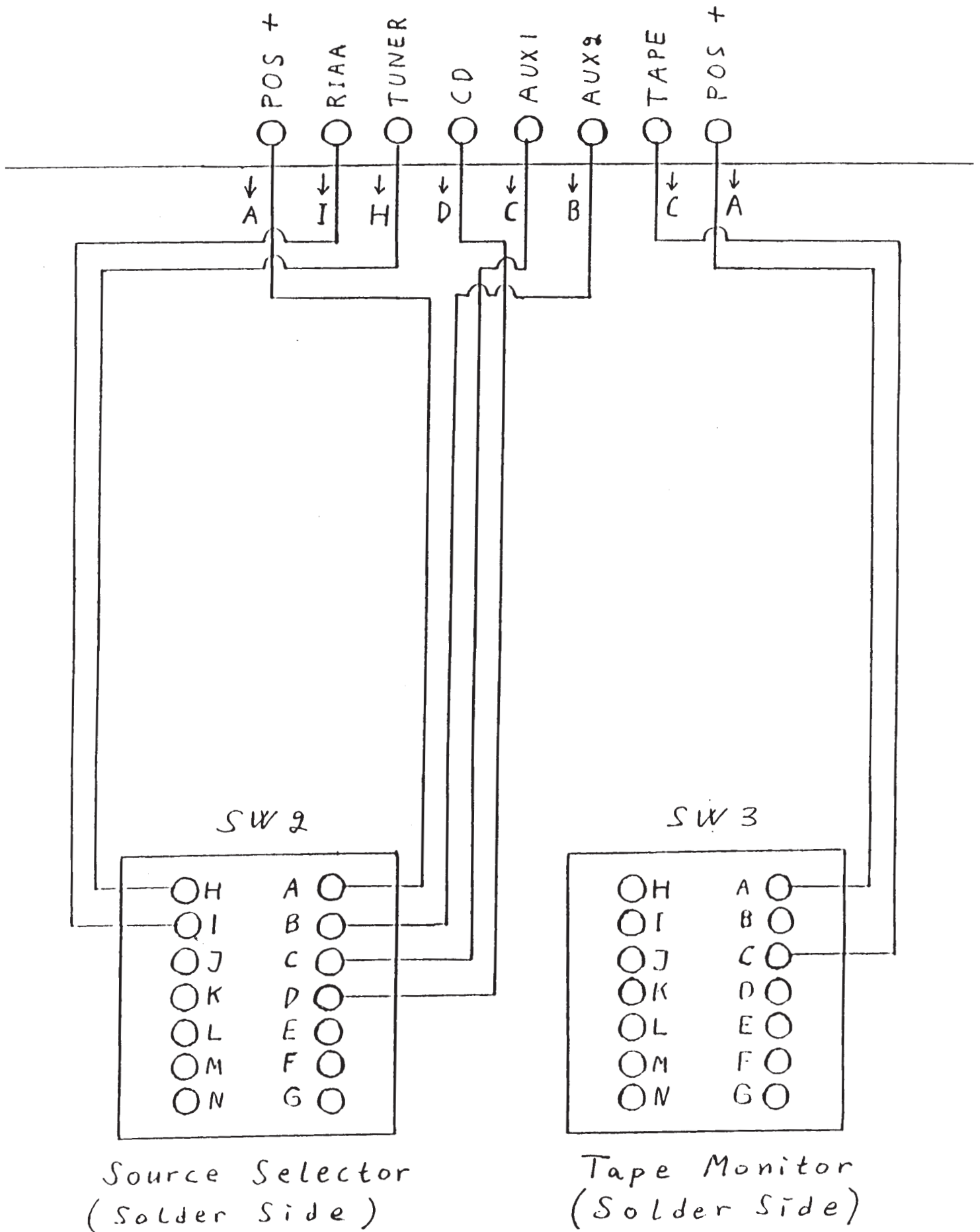

1-10-014-00 Mainboard CSA 14 equipped

Article	Description	
2-49-014-00	Main board CSA-14	KK1
2-61-722-84	Metalfilm 0,6W	1K R1,101,20,120,57,157
2-61-741-99	Metalfilm 0,6W	47K5 R2,102,10,110,11,111
		R12,112,13,113,14,114,86,88
2-61-726-07	Metalfilm 0,6W	2K R3,103,28,128
2-61-733-57	Metalfilm 0,6W	8K66 R4,104
2-61-745-53	Metalfilm 0,6W	97K6 R5,105
2-61-732-82	Metalfilm 0,6W	7K50 R6,106
2-61-729-38	Metalfilm 0,6W	3K83 R7,107,43,143
2-61-740-66	Metalfilm 0,6W	37K4 R8,108
2-61-745-61	Metalfilm 0,6W	100K R9-109-21-121-83
2-61-700-07	Metalfilm 0,6W	10R R15,115,16,116,17,117,18,118
2-61-719-71	Metalfilm 0,6W	536R R19,119,75,91
2-61-721-02	Metalfilm 0,6W	681R R22,122
2-61-700-03	Metalfilm 0,6W	3R9 R23,123,24,124
2-61-720-11	Metalfilm 0,6W	576R R25,125
2-61-733-32	Metalfilm 0,6W	8K25 R26,126,56,156
2-61-715-18	Metalfilm 0,6W	221R R27,127,34,134,35,135
2-61-737-46	Metalfilm 0,6W	20K R29,129
2-61-726-56	Metalfilm 0,6W	2K21 R30,130,90
2-61-742-80	Metalfilm 0,6W	56K2 R31,131
2-61-724-66	Metalfilm 0,6W	1K5 R32,132,33,133,44,144
2-61-716-90	Metalfilm 0,6W	316R R36,136
2-61-712-11	Metalfilm 0,6W	118R R37,137
2-61-737-04	Metalfilm 0,6W	18K2 R38,138,39,139,61,161
2-61-718-98	Metalfilm 0,6W	464R R40,140
2-61-703-79	Metalfilm 0,6W	22R1 R42,142
2-61-732-41	Metalfilm 0,6W	6K81 R45,145
2-63-707-59	Metalfilm 1W	46R4 R46,146,47,147
2-60-782-16	Metalfilm 1W	4R7 R48,148,49,149
2-62-054-22	Wirewound 4W	R22 R52,152,53,153
2-60-792-55	Metalfilm 2W	10R R58,158
2-61-756-91	Metalfilm 0,6W	976K R60,160,62,162
2-60-795-37	Metalfilm 2W	2K2 R63,163,64,164
2-60-785-88	Metalfilm 1W	5K6 R65,66
2-61-711-46	Metalfilm 0,6W	100R R67,68,71,171,72,172
2-60-785-62	Metalfilm 1W	3K9 R69,169,70,170
2-60-784-22	Metalfilm 1W	270R R73,74
2-61-707-59	Metalfilm 0,6W	46R4 R76,77,78,79,80,81
2-61-749-34	Metalfilm 0,6W	221K R82,182,87
2-61-743-22	Metalfilm 0,6W	61K9 R84
2-61-752-38	Metalfilm 0,6W	392K R85
2-61-717-99	Metalfilm 0,6W	383R R89
2-60-783-72	Metalfilm 1W	100R R92,192,93,193
2-60-164-55	Nullohm resistor	2,5A J1-36
2-33-154-54	Fuseholder	PCF
2-48-936-08	Solder tag	ST
2-48-240-66	Crimpconnector	CC
2-64-682-35	Trimpotentiometer	1 Kohm P1,101
2-65-540-10	Polypropylen	100pF 630V C1,101,16,116
2-67-132-148	Elektrolyt	47uF 16V C2,102
2-65-500-06	Polypropylen	33nF 63V C3,103
2-65-500-01	Polypropylen	10nF 63V C4,104
Blanktråd		C5,105
2-65-141-490	Polykarbonat	3,3uF 100V C6,106
2-65-540-04	Polypropylen	47pF 630V C7,107
2-65-751-09	Ceramic cap.	10pF 200V C8,108
2-65-446-39	Polyester	2,2uF 160V C9,109

2-65-530-51	Polypropylen	510pF	400V	C10,110,13,113
2-65-105-917	Polykarbonat	100nF	100V	C14,114,15,115,24,25,17,117.
2-65-141-488	Polykarbonat	220nF	100V	C30,31,32,132,33,133
				C38,138,39,139,43,51,60,160
2-65-141-625	Polyester	470nF	100V	C18,118,19,119
2-65-119-777	Polyester	1uF	63V	C20,120,21,121
2-67-141-133	Elektrolyt	10000uF	50V	C22,122,23,123
2-67-105-538	Elektrolyt	470uF	25V	C26,27,28,29
2-67-105-558	Elektrolyt	220uF	50V	C34,134,35,135,36,136
				C37,137,58,158,59,159,61,161,
				C40,140
2-67-105-523	Elektrolyt	1500uF	25V	C41,141,157
2-65-141-587	Polyester	470nF	63V	C42,50,54
2-67-140-970	Elektrolyt	220uF	25V	C44,45,46,47,48,49
2-65-192-76	Polyester	330nF	63V	C52,53
2-67-132-112	Elektrolyt	47uF	6,3V	T1,101,2,102
2-71-006-13	Transistor	2SK170GR		T3,103,4,104,6,106
2-71-091-43	Transistor	2SA2240GR		T5,105
2-71-091-35	Transistor	2SA970GR		T7,107
2-71-310-65	Transistor	ZTX653 NPN		T9,109,17,19,119,25
2-71-041-36	Transistor	BD139		T10,110
2-71-310-75	Transistor	ZTX753 PNP		T11,111
2-71-093-41	Transistor	2SC2238B		T12,112
2-71-093-33	Transistor	2SA968B		T13,113
2-71-093-18	Transistor	2SC3281B		T15,115
2-71-093-10	Transistor	2SA1302		T18,20,120
2-71-041-44	Transistor	BD140		T21,22,23,24
2-71-056-04	Transistor	BC550B		C1,101,2,102,9,10,13,113
2-70-005-16	Diod	1N4007 1A 1000V		C14,114,17,18,19,20,21,22,
				D3,103,4,104
2-70-062-81	Diod	BZX85C15 1.3W 15V		D5,105,6
2-70-010-43	Diod	BR104 10A 400V		D7,8
2-70-080-06	Diod	BR38 3A 400V		D11,12
2-70-059-07	Diod	BZX79C16 0.5W 16V		D15,115,16,116
2-70-057-49	Diod	BZX79C24 0.5W 24V		D23,24,25
2-70-005-57	Diod	1N4148 0,15A 75V		LED1,101,2,102,3,103,42,142
2-75-054-15	Diod	red		LED4
2-75-006-48	Diod	green for frontpanel		LED5
2-75-006-50	Diod	green for mainboard		IC1,101,2,102
2-73-073-66	Operationamplifier	NE5534N		IC3,103
2-73-117-07	Operationamplifier	TL071CP		IC4,104
2-73-091-56	Regulator	7806		IC5,6
2-73-090-20	Transistor	LM7812CT 35V		V1,V101.
2-74-208-88		6922		HS1
2-75-626-97	KS160-1000-E	0,65° at 75W		HS2-3
2-75-621-68	Heatzink	K18-2 SOT32		SL1,2
2-75-645-37	Isolationwasher	for TO220		SL3
2-75-645-45	Isolationwasher	for TOP3		DL1
2-48-120-12	IC-socket	8-pins		TS
2-48-087-39	Tube socket	9 poles		RL1-6
2-37-125-750	Relay	RY12 W-K 12V 240 ohm		RL7
2-37-132-848	Relay	VB12 STCU-5 12v 270R		SW1,2
2-35-133-798	Switch	RTA C30		RCA1
2-42-266-02	RCA-connector	2-pin T5958		RCA2
2-42-266-06	RCA-connector	6-pin T5952		

1-50-014 CSA 14 Amplifier

Article	Description
2-48-865-00	Feet for CTA chassis
2-50-014-00	Chassis CSA 14
2-48-886-20	M6 x 20 M6S screw
2-48-896-30	M6 AZ FZB YT lockwasher
2-48-896-10	M6 M6M-ISO not
2-35-040-57	Powerswitch
2-40-734-58	Groundconnector T51
2-48-884-16	M4 x 16 M6S screw
2-48-894-30	M4 lockwasher
2-48-894-10	M4 M6M steelnot
2-40-738-21	Speaker terminal 4mm red
2-40-738-05	Speaker terminal 4mm black
1-10-014-00	Mainboard CSA 14 equipped
1-10-014-20	Volumeboard fully equipped
2-57-014-220	Transformer CSA-014 220V
2-48-886-60	M6 x 60 M6S screw
2-48-896-30	M6 AZ FZB YT lockwasher
2-48-896-10	M6 M6M-ISO not
2-43-209-33	Power-inlet 6,3 x 0,8mm
2-65-645-87	Capasitor X2 22nF 250V
2-48-898-40	M8 washer SRB 1/4
2-48-895-30	M5 lockwasher
2-48-223-34	Ringterminal M5
2-48-225-16	Crimpterminal 6,3 x 0,8 mm
2-48-223-26	Ringterminal M4
2-48-883-10	M3 x 10 MRX screw
2-55-032-14	Cable tie 100 mm
2-33-106-12	Fuse 3,15 A
2-33-106-20	Fuse 4,00 A
2-48-883-06	M3 x 6 MRX screw
2-50-014-20	Front CSA 14 silver
2-48-885-16	M5 x 16 P6SS black screw
2-48-895-10	M5 M6M-ISO not
2-38-150-00	Knob without ring
2-38-150-10	Ring: On/off tape knob
2-38-150-15	Ring: On/off power knob
2-38-150-20	Ring: Volume knob
2-38-150-30	Ring: Balans knob
2-38-150-35	Ring: CD/AUX knob
2-48-900-10	Plastwasher for knobs
2-48-883-04	M3 x 4 P6SS black screw
2-50-301-10	Bonnet CTA-301
2-48-884-08	M4 x 8 K6S screw
2-48-894-20	M4 black steelwasher
2-43-313-77	Powercord
2-51-000-11	Carton with text 'Copland'
2-51-000-23	Inner packing material

