

COPLAND

VALVE AMPLIFIER

SERVICEMANUAL

FOR

CTA - 505

Bias adjustment for Copland CTA-505:

1. If you put in a new set of tubes, you should first turn all 4 bias-adjustment potentiometers P1-P102, fully in counter-clockwise direction.
2. Turn on the amplifier, and let it warm up for 1 minute.
3. Connect a voltmeter (on mV measuring range) with - to chassis ground (use the earth point situated between the main power- transformer and the right outputtransformer)

Connect the positive + test-probe from multimeter to point S left, for measuring Bias for tube V4 and adjust with P1 to 45 mV.

For tube V5 the measuring point is T left, and adjustment is done with P2

For tube V104 the measuring point is S right, and adjustment is done with P 101.

For tube V105 the measuring point is T right and adjustment is done with P102.

When you have adjusted all 4 tubes, please repeat, as the adjustment of one tube, affects the other tubes slightly.

4. Let the amplifier heat for 30 minutes, then please repeat point 3.
5. If the tubes have been used for some time, the bias should already be close to the right level, so you can start bias-adjustment at point 2. (You don't need to do point 1)
6. 45 mV = 45 mA per tube (same value for all 4 tubes)

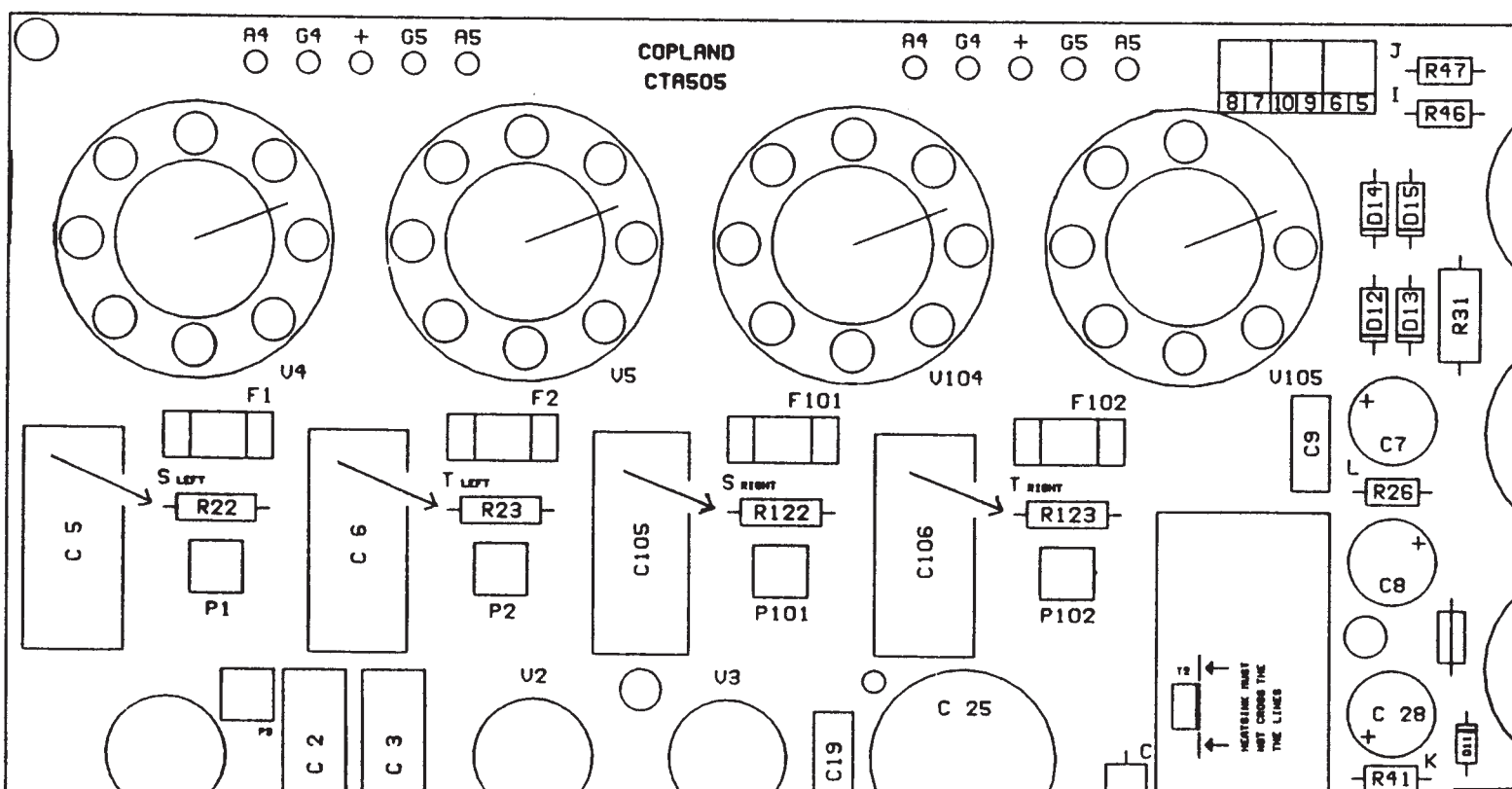

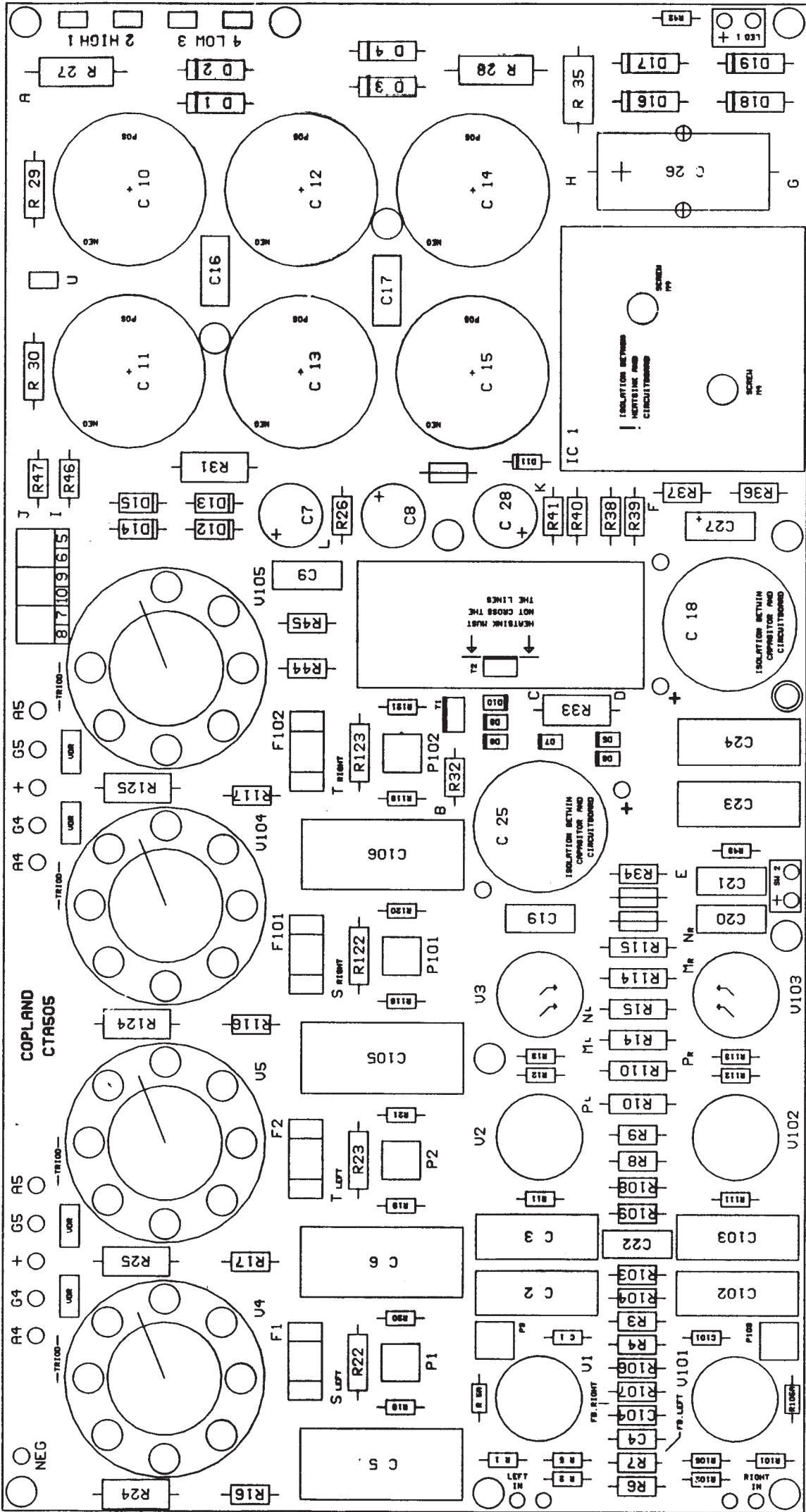

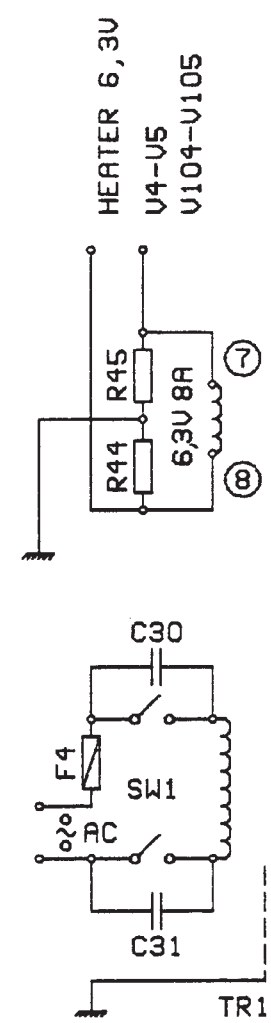
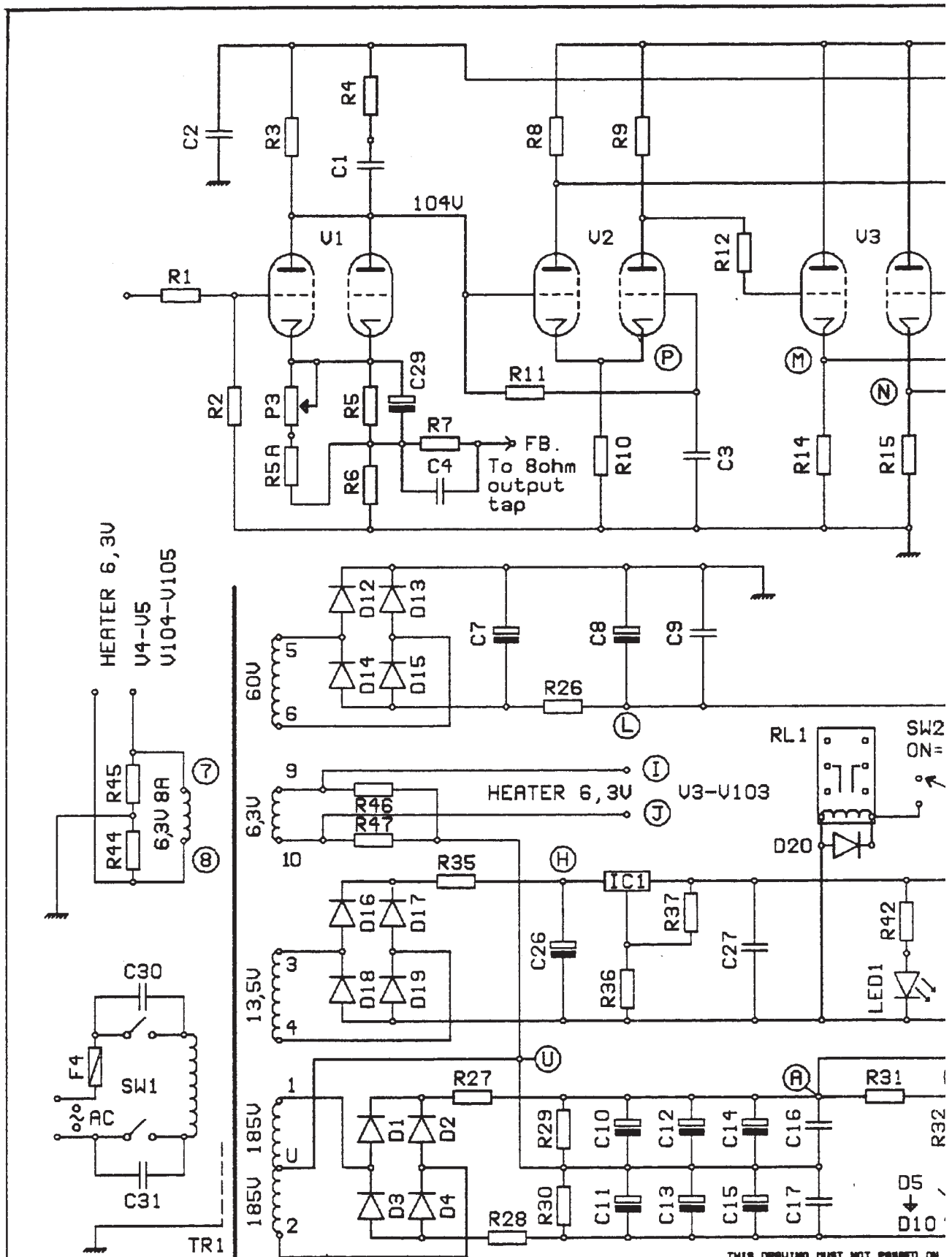

COPLAND CTA505 O.M. FI

All Voltage are $\pm 10\%$

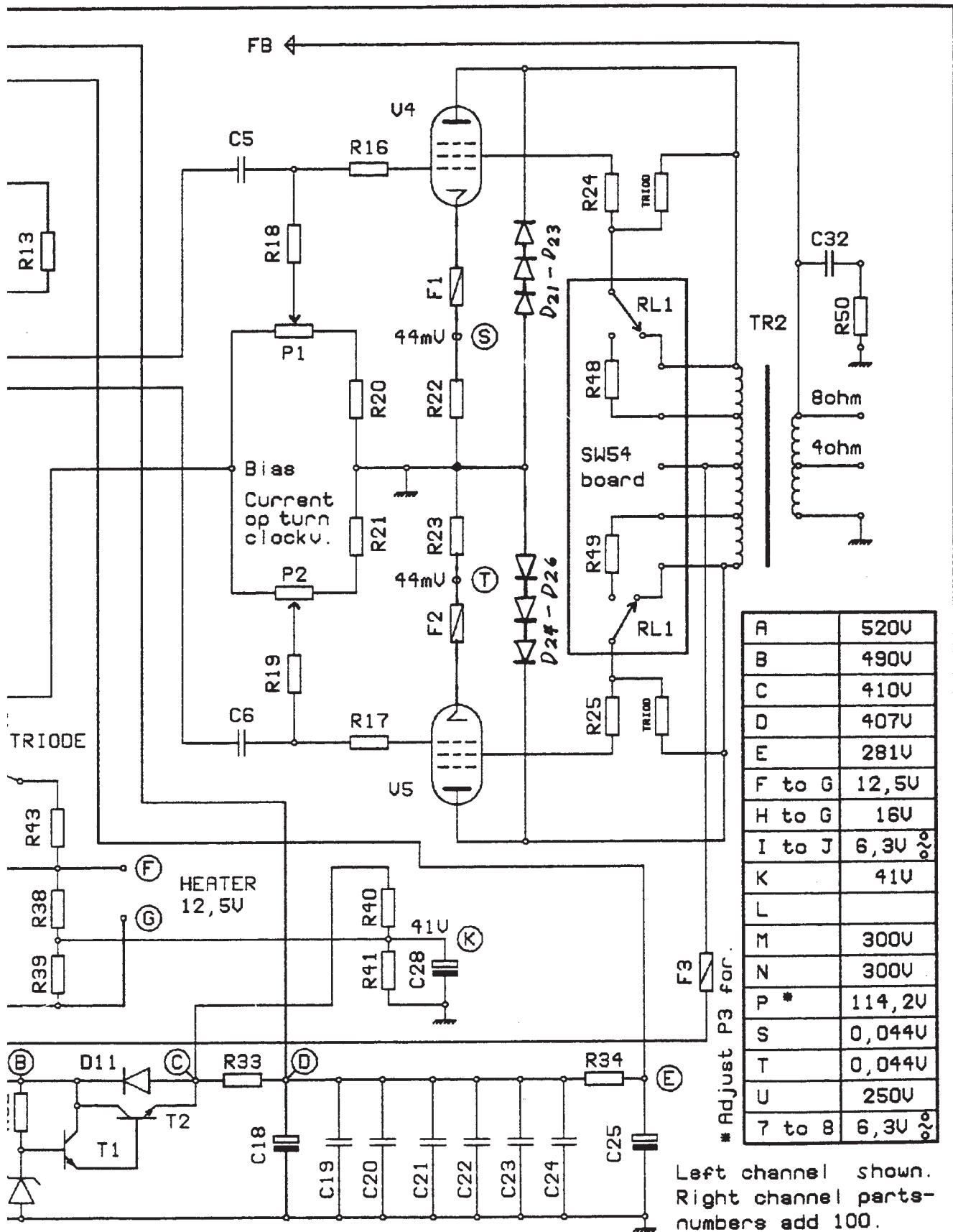

A	520V
B	490V
C	410V
D	407V
E	281V
F to G	12,5U
H to G	16U
I to J	6,3U
K	41V
L	
M	300V
N	300V
P *	114,2V
S	0,044U
T	0,044U
U	250V
7 to 8	6,3U

TO, COPIED OR USED BY ANY UNAUTHORIZED PERSONS.

Article	Description	Position
2-49-505-00	Main board CTA 505	KK
2-61-726-56	Metalfilm 0,6W 2K21	R1,101
2-61-745-61	Metalfilm 0,6W 100K	R2,102
2-63-747-44	Metalfilm 1W 150K	R3,103
2-61-733-32	Metalfilm 0,6W 8K25	R4,104
2-61-724-09	Metalfilm 0,6W 1K3	R5,105
2-61-721-28	Metalfilm 0,6W 715R	R5A,105A
2-63-711-46	Metalfilm 1W 100R	R6,106
2-63-726-07	Metalfilm 1W 2K	R7,107
2-63-741-16	Metalfilm 1W 41K2	R8,108
2-63-741-57	Metalfilm 1W 44K2	R9,109
2-60-986-53	Metalfilm 3W 22K	R10,110
2-61-756-18	Metalfilm 0,6W 825K	R11,111
2-61-719-71	Metalfilm 0,6W 536R	R12,112,13,113,42
2-60-987-29	Metalfilm 3W 82K	R14,114,15,115
2-63-722-84	Metalfilm 1W 1K	R16,116,17,117,36
2-61-744-70	Metalfilm 0,6W 82K5	R18,118,19,119
2-61-737-04	Metalfilm 0,6W 18K2	R20,120,21,121
2-60-791-31	Metalfilm 2W 1R	R22,122,23,123
2-62-060-64	Wirewound 5W 100R	R24,124,25,125,33
2-63-719-71	Metalfilm 1W 536R	R26
2-60-462-13	Wirewound 5W 4R7	R27,28
2-60-987-37	Metalfilm 3W 100K	R29,30
2-62-061-22	Wirewound 5W 1K	R31
2-60-796-93	Metalfilm 2W 47K	R32+TRIOD
2-60-797-01	Metalfilm 2W 56K	R34 (56K + 619K)
2-61-754-69	Metalfilm 0,6W 619K	
2-62-060-33	Wirewound 5W R33	R35
2-63-711-87	Metalfilm 1W 110R	R37
2-60-793-70	Metalfilm 2W 100R	R38,39,46,47
2-60-797-84	Metalfilm 2W 270K	R40
2-63-739-51	Metalfilm 1W 30K1	R41
2-61-700-04	Metalfilm 0,6W 4R75	R43
2-60-164-55	Nullohm resistor 2,5A	R45 + 3
2-64-683-26	Trimpotentiometer 10 Kohm	P1,101,2,102
2-64-682-35	Trimpotentiometer 1 Kohm	P3,103
2-65-540-12	Polypropylen 120pF 630V	C1,101
2-65-449-51	Polypropylen 470nF 630V	C2,102,23,24
2-65-123-452	Polypropylen 2,2uF 400V	C3,103
2-65-540-47	Polystyren 470pF 630V	C4,104
2-65-449-93	Polypropylen 2200nF 630V	C5,105,6,106
2-67-105-637	Elektrolyt 330uF 100V	C7,8
2-65-398-11	Polyester MKC 1000nF 100V	C9,27
2-67-537-84	Elektrolyt 470uF 385V	C10,11,12,13,14,15
2-65-123-427	Polypropylen 100nF 400V	C16,17
2-67-599-48	Elektrolyt 100uF 500V	C18,25
2-48-898-25	M8 rubberwasher	
2-65-158-652	Polypropylen 630V 47nF	C19,20,21,22
2-67-053-21	Elektrolyt 4700uF 25V	C26
2-67-105-663	Elektrolyt 47uF 250V	C28
2-70-036-84	Diod 1N5408 3A 1000V	D1,2,3,4
2-70-063-56	Diod BZX85C30 1.3W 30V	D5 variabel: 12 - 43 volt
2-70-068-30	Diod BZX85C75 1.3W 75V	D6,7,8,9,10
2-70-005-16	Diod 1N4007 1000V 1A	D11,12,13,14,15+12ST MELLAN TRIOD
2-70-036-43	Diod 1N5404 3A 400V	D16,17,18,19
1-20-401-20	LED with long cable	LED
2-71-012-31	Transistor BUT11A	T1
2-73-126-55	Regulator LM350K	IC1

1-10-505-00

CTA 505 Main board equip.

Article	Description	Position
2-48-087-39	Tube socket 9 poles	TS1
2-48-046-05	Tube socket octal	TS2
2-33-154-54	Fuseholder	PCF
2-75-620-93	KG 46-25,4-T03	HS1
2-75-647-01	KS70.5-37,5E	HS2
2-71-012-31	Transistor BUT11A	T2
2-48-883-10	M3 x 10 MRX screw	
2-48-893-20	M3 not with nylonlock	
2-35-133-798	Switch RTA C30	SW1
2-35-133-804	RTA coding pin	
2-48-374-64	Terminal block 10/2	
2-48-375-22	Terminal block 5/4	
2-48-883-13	M3 x 12 MRX screw	
2-48-893-20	M3 not with nylonlock	
3-55-286-82	Kable 0,5mm grey	
3-55-286-82	Kable 0,5mm grey	
3-55-300-27	Kable 0,75 mm red	
3-55-300-01	Kable 0,75 black	
3-55-805-01	Microphone kable black	
2-55-033-10	Cable tie base 13 x 13 mm	
2-55-032-48	Cable tie 200 mm	
2-55-032-14	Cable tie 100 mm	
	kabel till trafo	

1-10-505-30

CTA 505 Switchboard equip.

Article	Description	Position
2-49-504-20	Switchboard SW54 CTA-504	SW55
2-60-164-55	Nullohm resistor 2,5A	R48,49
2-70-005-16	Diod 1N4007 1000V 1A	D18
2-37-132-848	Relay VB12 STCU-5 12v 270R	RL1

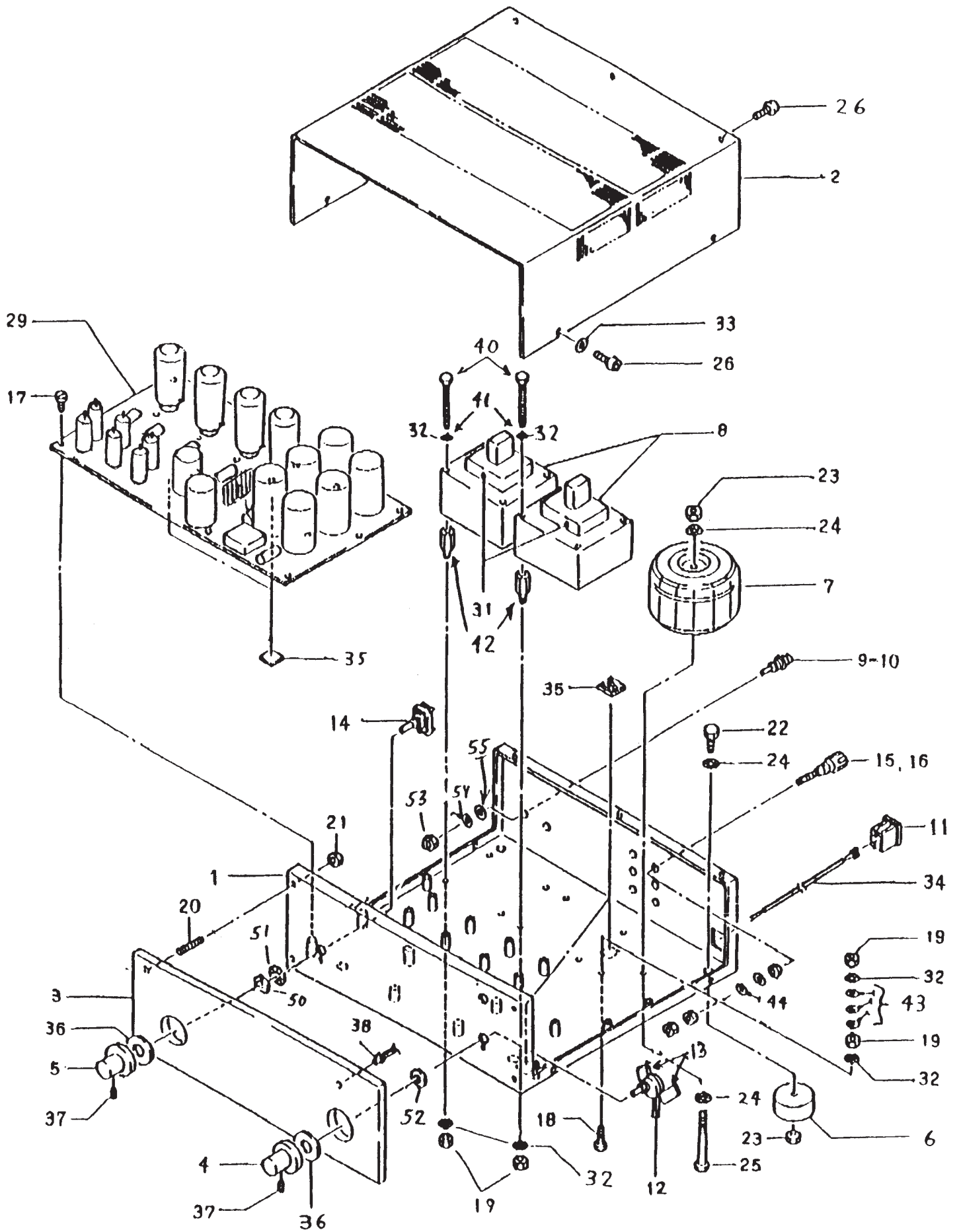

Article	Description	Position
2-43-313-77	Powercord	
2-50-505-20	CTA 505 Front silver	3
2-50-505-25	CTA 505 Front black	3
1-30-000-20	1 pair of silver knobs	4 + 5
1-30-000-21	1 pair of black knobs	4 + 5
2-33-105-54	Fuse 1,00 A	
2-33-105-39	Fuse 630 mA	
2-33-104-97	Fuse 250 mA	
2-33-106-12	Fuse 3,15 A	
2-57-505-220	Toroidtransf. CTA-505 220V	7
2-48-225-16	Crimpterminal 6,3 x 0,8 mm	
2-48-223-26	Ringterminal M4	43
2-56-504-00	Transf. 4K2B CTA-504-505	31
2-65-123-430	Polypropylen 220nF 250V	} Mounted on 31
2-60-982-57	Metalfilm 3W 10R	
2-50-505-00	CTA 505 Chassis	1
2-48-865-00	Feet for CTA chassis	6
2-48-899-60	M10 washer	
2-48-886-20	M6 x 20 M6S screw	22
2-48-896-10	M6 M6M-ISO not	23
2-48-896-30	M6 AZ FZB YT lockwasher	24
1-20-401-10	Cable from powerinlet	34
2-35-040-57	Powerswitch	12 + 52
2-40-738-05	Speaker terminal 4mm black	15
2-40-738-21	Speaker terminal 4mm red	16
2-48-884-16	M4 x 16 M6S screw	18
2-48-894-10	M4 M6M steelnot	19
2-48-893-30	M3 lockwasher	
1-20-505-30	Cabels for CTA 505	
2-65-645-87	Capasitor X2 22nF 250V	13
2-42-257-54	RCA socket M8 Bennic red	10 + 53 + 54 + 55
2-42-257-55	RCA socket M8 Bennic black	9 + 53 + 54 + 55
2-55-033-10	Cable tie base 13 x 13 mm	35
2-55-032-14	Cable tie 100 mm	
1-10-505-00	CTA 505 Main board equip.	29
1-10-505-30	CTA 505 Switchboard equip.	8
2-48-886-80	M6 x 80 M6S screw	25
2-48-896-30	M6 AZ FZB YT lockwasher	24
2-48-896-10	M6 M6M-ISO not	23
2-48-894-10	M4 M6M steelnot	19
2-48-894-30	M4 lockwasher	32
2-48-884-70	M4 x 70 MCS screw	40
2-48-894-35	M4 lockwasher	41
2-74-052-77	Tube E83CC / 12AX7A	
2-74-052-69	Tube E82CC / 12AU7A	
2-74-209-53	Tube 6550	
2-84-900-01	Test card	
2-48-883-06	M3 x 6 MRX screw	17
2-48-885-16	M5 x 16 P6SS black screw	20
2-48-895-10	M5 M6M-ISO not	21
2-48-900-10	Plastwasher for knobs	36
2-50-401-10	CTA 401, 501, 505 Bonnet	2
2-48-884-08	M4 x 8 K6S screw	26
2-48-894-20	M4 black steelwasher	33
2-51-000-10	Carton with text 'Copland'	
2-51-000-20	Inner packing material	
2-51-000-21	Inner packing material	
2-84-505-00	Usermanual CTA 505	