

AUDIO SYSTEMS

CD 60

Service Manual

CD60 SERVICE MANUAL ADDENDUM

The following service information has been identified since the issue of the CD60 service manual.

1) Transformer (On CD60 Ser. No. 1-420)

A transformer problem has been identified, which results in the unit blowing fuses within the first few days of use. This fault may be confirmed by measuring the resistance of the primary windings. With the **power off and the mains lead disconnected** and a working fuse fitted, the resistance measured across the Live and Neutral pins on the IEC Mains Inlet should be:

110-120V	17 Ohms +15% -8%
220-240V	68 Ohms +15% -8%

The value will, of course, vary slightly during measurement: due to the reactive nature of the component under test. Any significant variation from the above values will indicate a transformer fault. Please note that the fault is fail safe if the correct value of fuse is fitted. The transformer will not exceed its safe working temperature and mains voltages remain isolated from the secondaries.

If further investigation is required, the resistance of winding Yellow - White or Grey - Pink should read 34 Ohms +15% -8%. There should be an open circuit between the two primary windings. Contact Creek Service for a replacement transformer.

2) Secondary Voltages

This information was omitted from the Service Manual. RMS voltages are shown for the different nominal mains supplies supported by this equipment.

<u>Referenced to TP1 (0V):</u>		<u>(240/120V/100V)</u>	<u>(220/110V)</u>
Blue	B-E	13 Vrms	12 Vrms
Green	G-N	13 Vrms	12 Vrms
Red	R-D	22.5 Vrms	20.5 Vrms
Violet	V-T	22.5 Vrms	20.5 Vrms
Orange	O-E	2.1 Vrms	1.95 Vrms

3) MICROMEGA DACs (CD60 Ser No to 499)

Since the design of the CD60 it has been found that the Range of MicroMega D to A converters do not operate correctly when driven by the CD60. The CD60 has a high current capability driver which is designed to give high speed transitions on both leading and trailing edges. The output level is about 1.6Vp-p (unterminated) and 0.8Vp-p into a 75 ohm load. This level can be reduced, at the cost of some additional ringing on the waveform, to a level suitable for the MicroMega by changing R22 from 330R to 1K2. In addition it may be necessary to adjust the core in L1 for optimum results.

4) FUSE RATINGS

The fuse ratings defined from the CD60 are based on the IEC 127 standard. If replacing with UL198 or CSA C22.2 standard fuses (USA and Canada respectively), the equivalent fuse ratings are:

<u>IEC</u>	<u>UL/CSA</u>	
T500mA	T630mA "Slo-Blo"	(for 100/110/120Vac)
T250mA	T315mA "Slo-Blo"	(for 220/240Vac)

CD60

Service Manual

Contents

- 1 Technical Specification
- 2 Assembly and Faultfinding
- 3 Parts list
- 4 Circuit Diagrams and PCB layouts



**CLASS 1
LASER PRODUCT**

WARNING

Compliance with Safety Regulations require that this unit is restored to its original condition and that parts are used as specified in this document.

<p>Creek Audio Systems Rosehall Industrial Estate Coatbridge Strathclyde ML5 4TF Scotland Tel 0236 420199 Fax 0236 428230</p>	<p style="text-align: center;">Subject to alteration</p> <p style="text-align: center;">While the information in this document is believed to be correct, no liability is accepted for loss or damage arising from any errors which may have occurred</p>	<p>The contents, information and copyright of this document are the sole property of Creek Audio Systems and must not be published applied or copied without the express knowledge and permission of the owners</p>
Page 1		Issue 1 Jan 1992

TECHNICAL SPECIFICATION

Frequency Response	20Hz-20kHz +/-0.1dB at -10dB			
	<u>16Hz</u>	<u>1kHz</u>	<u>16kHz</u>	<u>20kHz</u>
Channel Balance	0.1 dB	0.1 dB	0.1 dB	
Channel Separation	-111 dB	-101 dB	-76 dB	-74dB
THD vs level	0 dB	-78 dB	-80 dB	-79 dB
	-24 dB	-75 dB	-72 dB	-64 dB
	-60 dB	-41 dB	-46 dB	-46 dB
	-80 dB		-22 dB	-32 dB
dithered	-90 dB	-12 dB		
Resolution	-60 dB	0.03 dB		
	-70 dB	-0.19 dB		
	-80 dB	-0.78 dB		
Deemphasis accuracy	-0.02 dB	+0.06 dB	-0.1 dB	
SNR (A-wtd) without emphasis		-112 dB		
	with emphasis		-114 dB	

Output Impedance	180 Ohms		
Peak Output level	2.24Vrms		
H x W x D (max ext dimensions)	90 x 422 x 290 mm		
Weight	5.8 kg		
Laser Diode	wavelength	780nm +/-0.7%	
	power out at diode	3mW (typ)	
	Output Power after objective lens	100uW	
Mains Voltage	220-240V setting	208 to 265V at 50 to 60 Hz	Fuse T250mA
	110-120V setting	103 to 140V at 50 to 60 Hz	Fuse T500mA
	100V (special transformer)	90 to 118V at 50 to 60 Hz	Fuse T500mA

WARNING

When the case of this unit is opened a mains voltage hazard exists. Appropriate precautions must be taken. Mains voltages ARE present on the PCB.



WARNING

This unit contains Static Sensitive Devices. During handling of disassembled parts ensure an anti static environment with a high resistance (safety) link to the bulk of the unit, or ground.



WARNING

Compliance with Safety Regulations require that this unit is restored to its original condition and that parts used are as specified in this document.



Voltage Selection

WARNING:
DISCONNECT FROM MAINS SUPPLY BEFORE ATTEMPTING THIS CHANGE.

This is achieved by selecting the correct setting on SW2, located near to the power switch. The appropriate Fuse should then be fitted in order to ensure the safe operation of this unit

GUIDE TO UNIT DISASSEMBLY

Mechanism:-

Remove the lid (7 screws).

Remove the lead to the tray motor (on the side of the mechanism) at CN7 and push the drawer out by approximately 3cm. NOTE: The drawer should NOT be manually operated unless CN7 is disconnected as damage can be caused to the servo electronics.

Remove the front panel (3 screws on unit base).

Remove the drawer assembly completely from the mechanism. Remove the three screws now showing. Lift the assembly slightly and disconnect the ribbon cable (CN5) and the disc motor lead (CN6). The ribbon cable is removed by sliding the connector body upwards.

PCB:-

Remove the laser mechanism as above.

Remove the display PCB by removing 2 screws connecting the display to the main PCB. Disconnect the 2 ten way connectors.

Remove the 5 hex spacers (5mm nut driver).

Remove 2 screws from the main PCB plus 2 screws from the rear panel (digital and analog out).

Remove 2 screws from the mains inlet and the screw holding the transformer down. Remove the screw holding the earth tag on the rear panel.

The PCB will now lift from the base.

Note: The PCBs used in the CD60 have plated through holes. Damage must be avoided. For component removal ensure the component lead solder is properly re-flowed or removed before attempting to remove the component.

Note: Anti Static precautions must be observed when handling the PCBs or Laser assembly.

Assembly is the reverse of removal.

Ensure that the earth strap is correctly re-seated, with a shake proof washer between the chassis and the crimp terminal. Ensure the 2 mains inlet screws are refitted, as these provide an additional safety earth to the chassis. Ensure that the front panel is re-seated correctly, so that it does not foul the tray or switch assemblies.

General

Deemphasis: The Deemphasis relay, which selects the additional filter function, is operated every time the drawer opens or closes, in order to maintain the reliability of the contacts. Thus, with the case top removed, a distinct click should be heard during drawer operations (at the point at which the Tray Switch operates).

Reset: A power on reset is applied to the system. This lasts a minimum of 0.5s, after which time the mute relay will open and the display light. Note that the display LED will operate at all times provided the +5V supply is present: giving a visible indication of the Power-On state, even if the display is muted.

Digital Output: As a service operation, the output waveform can be 'fine tuned' to modify the rise/fall times of the waveform by tuning the core of L1. The level can be adjusted by modifying R22, although this changes the waveform shape. For instance, R22=1K2 will give an underdamped 0.5Vp-p signal into 75 Ohms while R22=330R gives a critically damped 0.8Vp-p signal which most, but not all, outboard DACs can cope with.

TEST GUIDE				Guide	?	Check	At
POWER ON LASER	?	Check	At	Deemphasis OK	NO:	DEEM	tp35 tp45
		Sc					
		Si/RD	tp19				
		LO	TP10				
		LM	TP9				
FOCUSSING				ANALOG OUT OK	NO:	DAI	tp40
RD present	NO:	D1	TP6			DAI	tp42
		D2	TP8			WSI	tp38
		D3	TP5			CLI	tp39
		D4	TP4			EFAB	tp41
	YES:	FE	tp16			MUTE	CN4-9
		FElag	tp17			ATSB	CN4-10
						XSYS	CN4-1
						SDAB	tp36
						SCAB	tp37
						WSBD	IC12
						CLBD	IC12
DISC ROTATION STOPPED	NO:	MC	tp15 tp29			DABD	IC12
						IVleft	IC8-7
	YES:	TL	tp13			IVright	IC8-1
		REdig	tp20			AoutL	IC2-6
						AoutR	IC14-6
						Supplies to IC9	
TRACKING OK	NO:	B0	tp24	REGULATED VOLTAGES		Decoupling Caps	
		B1	tp25			Regulators	
		B2	tp26				
		B3	tp27				
		REdig	tp20	DISPLAY DIM		ZD4 or IC36	
		Cosc 1	tp21				
		Cosc 2	tp22	POWER OK but no Display and no normal Operation		RESET	
		RElag	R129			IC7	
		RAD+	ZD2				
		RAD-	ZD3				
JUMP TO TRACK	NO:	DODS	tp14				
		HFD	IC26				
SHOCK SENSITIVE		LENS	*				
		DISK					
		TL	tp13				
		HFin	IC26				
		IC30					
		IC32					
<p>* LENS: Great care must be taken in cleaning the lens. Do not apply any force to the assembly. Do not use a spray as this can force dirt particles into the focus motor assembly.</p>				<p>IC7 pin2 must be above threshold voltage 2.5V. Note that serious mains spikes may result in a CD unit RESET. Pin2 provides for rapid turn off of the output mute relay, before loss of the power supplies becomes noticeable. Delay is typically < 50ms from interruption of mains supply.</p> <p>In the case where a defect in the laser supply causes the destruction of the laser: requiring the replacement of the CDM4 unit, then a test circuit should be used in place of the laser assembly. Please contact Creek Audio Systems direct for information.</p>			

Test Information

Laser Current Adjust			(Meter Connection)
This procedure is required after any change to components in the laser assembly or circuit. Be aware that the pots are very sensitive			
power off	Adjust PR2 to read 1K Ohm +10% -0%	Ohms	TP1 (-) to TP9 (+)
power off	Adjust PR1 to mid position		
power on	Play disc. Adjust PR2 to read 50mV +/-4mV	Volts	TP3 (-) to TP2 (+)
power on	Play disc. Adjust PR1 to read +400mV +/-40mV	Volts	TP1 (-) to TP7 (+)

Test Point	Name	Test Description	Test at:															
13	TL	Intermittant groups of low pulses during search Square wave, T = 200us during track change	IC27 pin37															
14	DODS	Low pulses during Track change	IC27 pin4															
15	MC	Disc not running: 50% duty T = 11us square wave During Play: 60% high T = 11us square wave	IC27 pin31															
16	FE	50mV 9Hz sine wave plus broadband noise	R102-R105															
17	FElag	200mV 9Hz sine wave with +250mV offset (offset derived from PR1)	R107															
18	FOC-	During Play: -400mV offset plus dither from [17] Going from stop to play gives a complex burst waveform	R110-R111															
19	Si/RD	During Play: High During Stop: Low	IC27 PIN5															
20	Redig	Stop: High Play: Square wave train, average T = 1.7ms	IC27 PIN34															
21/ 22	Cosc	Sine Wave 1.2Vp-p T = 1.7ms	C134 C155															
23		Stop or Play: 2V When CD is nudged: Error voltage, returning to 2V	IC27 PIN11															
24/ 25/ 26/ 27	B0 B1 B2 B3	<table border="0"> <tr> <td><u>stop</u></td> <td><u>play</u></td> <td><u>track change</u></td> </tr> <tr> <td>low</td> <td>high</td> <td>activity</td> </tr> <tr> <td>high</td> <td>high</td> <td>activity</td> </tr> <tr> <td>high</td> <td>high</td> <td>activity</td> </tr> <tr> <td>high</td> <td>low</td> <td>activity</td> </tr> </table>	<u>stop</u>	<u>play</u>	<u>track change</u>	low	high	activity	high	high	activity	high	high	activity	high	low	activity	IC27 PIN10 IC27 PIN9 IC27 PIN8 IC27 PIN7
<u>stop</u>	<u>play</u>	<u>track change</u>																
low	high	activity																
high	high	activity																
high	high	activity																
high	low	activity																
28	XTAL	Approx. sine wave, centred at +2.5V T = 250ns	IC27 PIN38															
29	DISC	12cm disc: low 8cm disc: high	IC27 PIN35															
30	SPIN	low frequency (< 10Hz), 400mVp-p with DC offset Offset = -1V at disc start. = -0.6V at disc end	D16-D17															
31		Eye Pattern biased around +2V (overlapping 'sine' waves of different amplitudes forming a hatched pattern)	R69															

32		Stop: High Play: Low going data in bursts burst is < 10ms long every 27ms	IC27 PIN14
33		Stop: High Play: low going data in bursts (as [32])	IC27 PIN13
34		Stop: High Play: low going data in bursts (as [32])	IC27 PIN12
35	DEEM	High when recording uses De-emphasis	CN4 PIN2
36	SDAB	Low with high going data bursts	CN4 PIN3
37	SCAB	Stop: Low with high going data bursts (repeat time = 60us) Play: Low with high going data bursts (repeat time = 136us)	CN4 PIN4
38	WSI	44.1kHz square wave	CN4 PIN8
39	CLI	(44.1 x 64) kHz square wave	CN4 PIN7
40	DAI	Data stream. Activity during play	CN4 PIN6
41	EFAB	Stop: High Play: Low unless error is detected in data	CN4 PIN5
42		Data Stream after inversion. May be observable on an oscilloscope when Phase is switched.	IC19 PIN6
43		Active only when Dig Out is enabled, otherwise nothing	IC6 PIN9
44		Digital output Approx. 1.6Vp-p unterminated signal 0.6Vp-p terminated into 75 ohm load	DIG OUT
45		Deemphasis relay drive signal. Logic High when DEEM is high. Will change state momentarily when the drawer is opened, at the start and end of the drawer travel.	IC19 PIN3

Test Voltages

With Negative probe to TP1, Test the following points (as marked on the PCB:- grid locations can be found in the parts list) with a high input impedance voltmeter:

Name	Nominal	Range
+24V	24	23 > 25
-24V	24	23 > 25
+12V	12	11.5 > 12.5
+12v	12	11.5 > 12.5
-12V	-12	-11.5 > 12.5
+5V	5.2	5.0 > 5.2
+5A	5.2	5.0 > 5.25
+5B	5.2	5.0 > 5.25
+10V	10.5	10 > 11
-10V	-10.5	-10 > -11
-6V	6	5.8 > 6.2
-5V	-5.2	-5.05 > -5.25
-15V	-14.1	-14 > -15.2
+15A	14	13 > 15
-15A	-14	-13 > -15
+21V	18.7	18.2 > 19.2

(from IC28)

(from IC10)

Ref	Creek code	Desc	@PCB	@CCT	Ref	Creek code	Desc	@PCB	@CCT
C1	2767 6044	150u,40V	2,12	3 - 8B	C76	2767 6011	100u,25V	2,9	3 - 7D
C2	2601 0051	100n	3,12	3 - 8B	C77	2601 0084	22n,250V	16,9	1 - 4B
C3	2767 6011	100u,25V	3,12	3 - 7B	C78	2601 0084	22n,250V	17,9	1 - 4B
C4	2759 0380	2u2,25V	9,12	1 - 7E	C79	2601 0051	100n	15,9	1 - 4B
C5	2759 0380	2u2,25V	11,12	1 - 7B	C80	2601 0051	100n	0,9	3 - 8D
C6	2601 0051	100n	11,12	1 - 6B	C81	2601 0064	22n,100V	2,9	3 - 7D
C7	2606 0776	1n,1%	5,12	2 - 6C	C82	2606 0776	1n,1%	4,8	3 - 7C
C8	2767 6011	100u,25V	5,12	3 - 6B	C83	2606 0777	1500p,1%	4,8	3 - 7D
C9	2767 6011	100u,25V	14,12	3 - 1E	C84	2601 0084	22n,250V	16,8	1 - 4B
C10	2601 0064	22n,100V	3,12	3 - 7B	C85	2601 0084	22n,250V	17,8	1 - 4B
C11	2601 0051	100n	9,12	1 - 6E	C86	2767 6003	1000u,35V	17,8	1 - 4B
C12	2601 0064	22n,100V	5,11	3 - 6C	C87	2601 0051	100n	15,8	1 - 4B
C13	2759 6004	47p	15,11	1 - 3E	C88	2606 0776	1n,1%	5,8	3 - 7D
C14	2767 6044	150u,40V	0,9	3 - 8D	C89	2606 0776	1n,1%	5,8	3 - 6E
C15	2601 0070	1n,10%	1,11	3 - 8B	C90	2601 0064	22n,100V	6,8	3 - 6E
C16	2601 0070	1n,10%	1,11	3 - 8D	C91	2601 0051	100n	12,8	1 - 6B
C17	2767 6011	100u,25V	7,11	3 - 5D	C92	2767 6026	47u,50V	15,8	1 - 6E
C18	2601 0051	100n	14,11	3 - 1E	C93	2601 0064	22n,100V	3,8	3 - 7D
C19	2601 0064	22n,100V	15,11	3 - 4F	C94	2767 6011	100u,25V	6,8	3 - 6E
C20	2601 0064	22n,100V	4,11	3 - 7B	C95	2759 6004	47p	14,8	3 - 3D
C21	2606 0804	220n	9,11	3 - 4C	C96	2759 6004	47p	14,8	3 - 3D
C22	2606 0804	220n	9,11	3 - 4C	C97	2767 6011	100u,25V	3,8	3 - 7D
C23	2606 0804	220n	10,11	3 - 4C	C98	2759 0380	2u2,25V	8,8	1 - 7E
C24	2606 0804	220n	10,11	3 - 4C	C99	2601 0051	100n	10,8	3 - 1E
C25	2606 0804	220n	10,11	3 - 4C	C100	2767 6011	100u,25V	13,8	1 - 5C
C26	2606 0804	220n	10,11	3 - 4C	C101	2606 0804	220n	11,7	3 - 1C
C27	2606 0804	220n	11,11	3 - 3C	C102	2601 0051	100n	8,7	1 - 6E
C28	2767 6011	100u,25V	4,11	3 - 7B	C103	2601 0055	470n	9,7	2 - 6E
C29	2606 0776	1n,1%	7,11	3 - 5B	C104	2767 6011	100u,25V	9,7	2 - 6C
C30	2606 0776	1n,1%	4,11	3 - 7A	C105	2759 0380	2u2,25V	8,7	2 - 5D
C31	2606 0777	1500p,1%	4,11	3 - 7A	C106	2601 0064	22n,100V	9,7	2 - 5D
C32	2606 0776	1n,1%	4,11	3 - 7B	C107	2601 0064	22n,100V	9,7	2 - 6C
C33	2601 0064	22n,100V	11,10	3 - 3D	C108	2759 6004	47p	10,6	2 - 5E
C34	2767 6011	100u,25V	11,10	3 - 3D	C109	2759 0380	2u2,25V	8,6	1 - 7E
C35	0000 0000	not fitted	8,10	3 - 5C	C110	2759 0380	2u2,25V	13,7	1 - 7E
C36	2767 6011	100u,25V	8,10	3 - 3D	C111	2606 0804	220n	13,7	1 - 6D
C37	2601 0051	100n	15,10	1 - 4C	C112	2601 0072	2n2	10,6	2 - 6D
C38	2767 6011	100u,25V	17,10	1 - 4C	C113	2601 0062	10n	2,6	2 - 2C
C39	2767 6024	10u,50V	17,10	1 - 4C	C114	2601 0055	470n	3,6	2 - 2E
C40	2606 0776	1n,1%	5,10	3 - 6C	C115	2601 0066	47n	4,6	2 - 2E
C41	2601 0064	22n,100V	5,10	3 - 6C	C116	2601 0070	1n,10%	4,6	2 - 3D
C42	2767 6035	22u,63V	6,10	3 - 5B	C117	2759 6008	100p	5,6	2 - 3E
C43	2601 0064	22n,100V	6,10	3 - 5B	C118	2601 0064	22n,100V	1,6	2 - 1C
C44	2601 0064	22n,100V	7,10	3 - 5D	C119	2601 0064	22n,100V	3,6	2 - 2C
C45	2601 0064	22n,100V	9,10	3 - 3D	C120	2601 0051	100n	7,6	1 - 6E
C46	2601 0064	22n,100V	14,10	3 - 4E	C121	2759 6002	33p	9,6	2 - 7E
C47	2601 0066	47n	15,10	3 - 4E	C122	2606 0804	220n	5,6	2 - 2E
C48	2767 6011	100u,25V	6,10	3 - 6C	C123	2767 6035	22u,63V	2,6	2 - 2D
C49	2601 0064	22n,100V	8,10	3 - 5E	C124	2759 6023	470p	1,6	2 - 2C
C50	2601 0051	100n	16,10	1 - 5C	C125	2759 0380	2u2,25V	13,6	1 - 7C
C51	0000 0000	not fitted	8,10	3 - 5E	C126	2767 6011	100u,25V	12,5	2 - 5B
C52	2759 6023	470p	11,10	3 - 4D	C127	2601 0064	22n,100V	11,5	2 - 5B
C53	2601 0066	47n	14,10	3 - 4F	C128	2759 0380	2u2,25V	13,5	1 - 7C
C54	2601 0071	1.5n,10%	17,10	1 - 4B	C129	2759 6012	220p	1,5	2 - 1D
C55	2767 6011	100u,25V	8,10	3 - 3D	C130	2601 0051	100n	15,5	1 - 6C
C56	2601 0064	22n,100V	9,10	3 - 3D	C131	2601 0064	22n,100V	4,4	2 - 3E
C57	2767 6011	100u,25V	5,9	3 - 6D	C132	2601 0056	680n	1,4	2 - 5C
C58	2606 0776	1n,1%	6,10	3 - 6E	C133	2601 0051	100n	2,4	2 - 5C
C59	2759 0380	2u2,25V	11,10	1 - 7B	C134	2606 0750	8n2	7,3	2 - 4D
C60	2606 0776	1n,1%	7,10	3 - 5D	C135	2601 0051	100n	13,4	1 - 6D
C61	2767 6003	1000u,35V	16,9	1 - 4B	C136	2601 0064	22n,100V	8,4	2 - 6E
C62	2601 0064	22n,100V	12,9	3 - 1D	C137	2759 0380	2u2,25V	14,4	1 - 7D
C63	2759 6004	47p	13,9	3 - 2D	C138	2767 6011	100u,25V	8,4	2 - 6E
C64	2767 6026	47u,50V	15,9	1 - 6E	C139	2767 6011	100u,25V	1,4	2 - 4E
C65	2601 0064	22n,100V	5,9	3 - 6E	C140	2601 0064	22n,100V	1,4	2 - 4E
C66	2601 0064	22n,100V	8,9	3 - 5D	C141	2767 6011	100u,25V	6,3	2 - 3C
C67	2767 6011	100u,25V	8,9	3 - 5E	C142	2759 0380	2u2,25V	14,4	1 - 7C
C68	2606 0804	220n	9,9	3 - 3D	C143	2601 0051	100n	15,3	1 - 4C
C69	2606 0804	220n	10,9	3 - 4D	C144	2601 0060	4n7	1,3	2 - 3E
C70	2606 0804	220n	10,9	3 - 4D	C145	2601 0065	33n	5,3	2 - 3C
C71	2606 0804	220n	10,9	3 - 4D	C146	2753 0200	3300u,35V	16,3	1 - 4C
C72	2606 0804	220n	10,9	3 - 4D	C147	2601 0072	2n2	4,3	2 - 2C
C73	2606 0804	220n	11,9	3 - 4D	C148	2601 0065	33n	5,3	2 - 3C
C74	2606 0804	220n	11,9	3 - 4D	C149	2767 6011	100u,25V	1,3	2 - 4E
C75	2767 6035	22u,63V	7,9	3 - 5D	C150	2601 0064	22n,100V	1,3	2 - 4E

Ref	Creek code	Desc	@PCB	@CCT	Ref	Creek code	Desc	@PCB	@CCT
C151	2601 0070	1n,10%	5,3	2 - 3C	IC11	3723 0035	LM7824	15,9	1 - 6E
C152	2601 0064	22n,100V	6,3	2 - 3C	IC12	6561 0031p	SAA7220	13,9	3 - 2C
C153	2601 0055	470n	3,3	2 - 3E	IC13	3723 6001	OPA2604	5,9	3 - 6E
C154	2601 0066	47n	4,3	2 - 5C					3 - 7D
C155	2606 0750	8n2	7,3	2 - 4D	IC14	3723 0033	NE5534AN	2,8	3 - 7D
C156	2601 0054	330n	1,3	2 - 4E	IC15	3723 0040	LM78L05	7,8	3 - 5D
C157	2601 0084	22n,250V	15,3	1 - 4C	IC16	3723 0037	LM7924	15,8	1 - 6F
C158	2601 0051	100n	14,3	1 - 6C	IC17	3723 0038	LM317T	8,8	1 - 7E
C159	2601 0084	22n,250V	14,3	1 - 4C	IC18	3723 0036	LM7912	15,8	1 - 6E
C160	2606 0804	220n	4,2	2 - 4D	IC19	3723 0031	74HCT86	10,7	3 - 1C
C161	2601 0084	22n,250V	15,2	1 - 3C					3 - 3F
C162	2601 0084	22n,250V	15,2	1 - 3C					3 - 6D
C163	2601 0051	100n	0,2	2 - 4E					1 - 5B
C164	2601 0064	22n,100V	2,2	2 - 6B	IC20	3723 0038	LM317T	13,7	1 - 7D
C165	2767 6011	100u,25V	3,2	2 - 6B	IC21	3723 0039	LM337T	8,7	1 - 7F
C166	2601 0054	330n	5,2	2 - 4D	IC22	3723 0041	LM340T-12	14,7	1 - 6B
C167	2767 6003	1000u,35V	16,2	1 - 4D	IC23	3723 0038	LM317T	13,6	1 - 7C
C168	2767 6011	100u,25V	1,2	2 - 6A	IC24	6561 0021pk	SAA7310	10,5	2 - 6D
C169	2767 6011	100u,25V	5,2	2 - 4D	IC25	6561 0032pk	MN4264	8,5	2 - 6E
C170	2767 6011	100u,25V	10,2	2 - 3F	IC26	6561 0018pk	TDA8808	4,5	2 - 2C
C171	2601 0054	330n	3,2	2 - 4F	IC27	6561 0020pk	XC409032P	10,5	2 - 3B
C172	2606 0804	220n	4,2	2 - 4D	IC28	3723 0038	LM317T	14,5	1 - 7B
C173	2601 0064	22n,100V	6,2	2 - 3D	IC29	3723 0039	LM337T	13,4	1 - 7B
C174	2601 0064	22n,100V	10,2	2 - 3F	IC30	6561 0022pk	TCA0372	2,4	2 - 3E
C175	2601 0064	22n,100V	1,2	2 - 6B	IC31	3723 0041	LM340T-12	15,3	1 - 6B
C176	2767 6011	100u,25V	8,1	2 - 3F	IC32	6561 0019pk	TDA8809	6,3	2 - 4C
C177	2601 0063	15n	9,2	2 - 3F	IC33	3723 0039	LM337T	13,3	1 - 7C
C178	2606 0760	3n3,2000V	19,1	1 - 1B	IC34	6561 0022pk	TCA0372	2,1	2 - 4F
C179	2601 0064	22n,100V	8,1	2 - 3F	IC35	6561 0023pk	NJM4560	9,2	2 - 3F
C180	2601 0072	2n2	2,1	2 - 4F	IC36	3723 0041	LM340T-12	14,1	1 - 6A
C181	2601 0051	100n	14,1	1 - 6A	L1	6561 0029pk	Dig_Trans	14,11	3 - 4E
C182	2767 6026	47u,50V	14,1	1 - 6A	PR1	2362 0008	20K pot	0,5	2 - 4E
C183	2601 0051	100n	2,0	2 - 7B	PR2	2362 0006	5K pot	0,3	2 - 1E
CN1	3422 0004	Audio Out	1,12	3 - 8B	Q1	3630 0045	ZTX453	1,11	3 - 8C
CN2	3422 0003	Digital Out	14,12	3 - 4E	Q2	3630 0045	ZTX453	3,9	3 - 6D
CN3	3432 0020	Mains In	16,12	1 - 1B	Q3	3630 0046	BF550	10,7	2 - 6D
CN4	0000 0000	not fitted	11,7	2 - 7D	Q4	3630 2042	BC548	10,5	2 - 5B
CN5	6561 0028pk	Zif 14w	1,5	2 - 1C	Q5	3630 2043	BC338	1,5	2 - 1D
CN6	6561 0003pk	Stocko-3W black	6,2	2 - 5F	Q6	3630 2042	BC548	10,4	2 - 6C
CN7	6561 0004pk	Stocko-3W grey	8,2	2 - 7B	Q7	3630 2042	BC548	10,3	2 - 7B
CN8	3443 0016	10w PCB Header	13,1	1 - 3F	Q8	3630 2044	BC558	12,3	2 - 3B
CN9	3443 0016	10w PCB Header	15,1	1 - 3A	Q9	3630 2044	BC558	5,0	2 - 2F
D1	3643 0701	1N4002	15,10	1 - 4B	Q10	3630 2044	BC558	6,0	2 - 2F
D2	3643 0702	1N4003	1,10	3 - 8C	R1	2069 6076	3K6,1%	11,11	1 - 7B
D3	3643 0701	1N4002	17,9	1 - 3C	R2	2069 6047	240R,1%	8,12	1 - 7E
D4	3643 0702	1N4003	3,9	3 - 6D	R3	2069 6060	750R,1%	9,12	1 - 7D
D5	3643 0701	1N4002	16,9	1 - 3C	R4	2069 6094	20K,1%	3,11	3 - 7B
D6	3643 0701	1N4002	16,9	1 - 4B	R5	2069 6077	3K9,1%	5,12	3 - 6B
D7	3643 0701	1N4002	17,9	1 - 4B	R6	2069 6076	3K6,1%	6,11	3 - 6C
D8	3643 0701	1N4002	16,9	1 - 4B	R7	2069 6076	3K6,1%	4,11	3 - 7A
D9	3643 0701	1N4002	16,9	1 - 4B	R8	2069 6016	12R,1%	4,11	3 - 7A
D10	3643 0340	1N4148	12,2	2 - 3B	R9	2069 6077	3K9,1%	6,11	3 - 5B
D11	3643 0701	1N4002	14,3	1 - 4C	R10	2069 6050	330R,1%	11,11	1 - 7B
D12	3643 0701	1N4002	16,3	1 - 4C	R11	2069 6038	100R,1%	15,11	1 - 3E
D13	3643 0701	1N4002	15,3	1 - 4C	R12	2069 6050	330R,1%	8,11	3 - 5C
D14	3643 0701	1N4002	15,2	1 - 4C	R13	2069 6045	200R,1%	1,11	3 - 8B
D15	3643 0340	1N4148	12,2	2 - 3B	R14	2069 6045	200R,1%	1,11	3 - 8D
D16	3643 0701	1N4002	3,2	2 - 5F	R15	2069 6084	7K5,1%	3,11	3 - 7B
D17	3643 0701	1N4002	4,1	2 - 5F	R16	2069 6077	3K9,1%	5,11	3 - 6B
F1	3461 0719	T250mA (220V)	18,11	1 - 1B	R17	2069 6065	1K2,1%	7,11	3 - 5C
F1	3461 0722	T500mA (110V)	18,11	1 - 1B	R18	2069 6077	3K9,1%	7,11	3 - 6B
F1	3469 0022	Fuse Holder	18,11	1 - 1B	R19	2069 6063	1K,1%	8,11	3 - 3D
F1	3469 0023	Fuse Cover	18,11	1 - 1B	R20	2069 6087	10K,1%	15,11	1 - 5C
IC1	3723 0039	LM337T	9,12	1 - 7E	R21	2069 6072	2K4,1%	5,11	3 - 7B
IC2	3723 0033	NE5534AN	3,11	3 - 7B	R22	2069 6065	1K2,1%	14,10	3 - 3E
IC3	3723 0040	LM78L05	6,11	3 - 5B	R23	2069 6059	680R,1%	14,11	3 - 4E
IC4	3723 0039	LM337T	11,11	1 - 7B	R24	2069 6063	1K,1%	16,11	1 - 5B
IC5	3723 6001	OPA2604	5,11	3 - 6C	R25	2069 6054	470R,1%	7,10	3 - 5B
				3 - 7B	R26	2069 6047	240R,1%	12,10	1 - 7B
IC6	3723 0032	74HCT365	13,11	3 - 3E	R27	0000 0000	not fitted	3,10	3 - 7B
IC7	3723 0034	TL7705ACP	16,10	1 - 5C	R28	2069 6054	470R,1%	7,10	3 - 5D
IC8	3723 6001	OPA2604	7,10	3 - 5E	R29	2069 6079	4K7,1%	16,10	1 - 4C
				3 - 5C	R30	2069 6060	750R,1%	11,9	1 - 7B
IC9	6561 0030pk	TDA1541 S1	9,10	3 - 4C	R31	2069 6079	4K7,1%	15,10	1 - 4C
IC10	3723 0038	LM317T	12,9	1 - 7B	R32	2069 6095	22K,1%	16,10	1 - 4C

Ref	Creek code	Desc	@PCB	@CCT	Ref	Creek code	Desc	@PCB	@CCT
R33	2069 6050	330R,1%	8,10	3 - 5E	R108	2069 6131	680K,1%	0,3	2 - 4E
R34	2069 6087	10K,1%	2,9	3 - 8B	R109	2069 6007	4R7,1%	0,4	2 - 4D
R35	2069 6076	3K6,1%	6,9	3 - 6E	R110	2069 6105	56K,1%	2,3	2 - 4E
R36	2069 6077	3K9,1%	7,9	3 - 6D	R111	2069 6116	160K,1%	2,3	2 - 4E
R37	2069 6077	3K9,1%	5,9	3 - 6D	R112	2069 6093	18K,1%	4,3	2 - 4C
R38	2069 6065	1K2,1%	7,9	3 - 5E	R113	2069 6089	12K,1%	5,3	2 - 3D
R39	2069 6077	3K9,1%	6,8	3 - 5D	R114	2069 6140	ZEROHM	8,3	2 - 6E
R40	0000 0000	not fitted	3,9	3 - 7D	R115	2069 6079	4K7,1%	10,3	2 - 6B
R41	2069 6063	1K,1%	1,9	3 - 7C	R116	2069 6047	240R,1%	13,3	1 - 7D
R42	2069 6079	4K7,1%	1,9	3 - 8C	R117	2069 6109	82K,1%	1,3	2 - 3E
R43	2069 6094	20K,1%	2,8	3 - 7D	R118	2069 6047	240R,1%	14,3	1 - 7C
R44	2069 6077	3K9,1%	5,9	3 - 6D	R119	2069 6062	910R,1%	14,3	1 - 7C
R45	2069 6076	3K6,1%	3,8	3 - 7C	R120	2069 6069	1K8,1%	4,2	2 - 4D
R46	2069 6072	2K4,1%	6,8	3 - 7D	R121	2069 6084	7K5,1%	10,2	2 - 6C
R47	2069 6063	1K,1%	9,8	3 - 6D	R122	2069 6091	15K,1%	6,2	2 - 3D
R48	2069 6016	12R,1%	3,8	3 - 7D	R123	2069 6087	10K,1%	12,2	2 - 3B
R49	2069 6063	1K,1%	14,8	3 - 2D	R124	2069 6103	47K,1%	6,2	2 - 3D
R50	2069 6119	220K,1%	14,8	3 - 2D	R125	2069 6081	5K6,1%	12,3	2 - 6B
R51	2069 6087	10K,1%	1,8	3 - 8D	R126	2069 6095	22K,1%	6,3	2 - 3C
R52	2069 6047	240R,1%	8,8	1 - 7E	R127	2069 6071	2K2,1%	13,2	2 - 3B
R53	2069 6063	1K,1%	10,8	3 - 3F	R128	2069 6083	6K8,1%	2,2	2 - 5C
R54	2069 6084	7K5,1%	3,8	3 - 7D	R129	2069 6080	5K1,1%	5,2	2 - 4C
R55	2069 6087	10K,1%	11,7	3 - 1C	R130	2069 6083	6K8,1%	1,2	2 - 5C
R56	2069 6140	ZEROHM	9,8	2 - 6E	R131	2069 6119	220K,1%	5,2	2 - 4D
R57	2069 6072	2K4,1%	7,7	1 - 7E	R132	2069 6111	100K,1%	9,2	2 - 3F
R58	2069 6063	1K,1%	13,7	3 - 1C	R133	2069 6110	91K,1%	9,2	2 - 3F
R59	2069 6047	240R,1%	7,7	1 - 7E	R134	2069 6007	4R7,1%	1,2	2 - 4E
R60	2069 6068	1K6,1%	14,7	1 - 5C	R135	2069 6000	1R,1%	10,2	2 - 3F
R61	2069 6040	120R,1%	12,7	3 - 1C	R136	2069 6007	4R7,1%	1,2	2 - 6A
R62	2069 6072	2K4,1%	7,7	1 - 7E	R137	2069 6109	82K,1%	3,2	2 - 4F
R63	2069 6047	240R,1%	13,7	1 - 7D	R138	2069 6079	4K7,1%	10,1	2 - 3F
R64	2069 6068	1K6,1%	10,7	2 - 6D	R139	2069 6007	4R7,1%	6,1	2 - 3D
R65	2069 6060	750R,1%	13,7	1 - 7D	R140	2069 6075	3K3,1%	8,2	2 - 4F
R66	2069 6077	3K9,1%	10,7	2 - 5D	R141	2069 6000	1R,1%	8,2	2 - 3F
R67	2069 6095	22K,1%	8,7	2 - 7D	R142	2069 6119	220K,1%	6,2	2 - 4C
R68	2069 6035	75R,1%	9,7	2 - 6D	R143	2069 6007	4R7,1%	6,1	2 - 6B
R69	2069 6095	22K,1%	9,7	2 - 6E	R144	2069 6081	5K6,1%	6,1	2 - 4F
R70	2069 6086	9K1,1%	9,6	2 - 5D	R145	2069 6105	56K,1%	10,1	2 - 3F
R71	2069 6047	240R,1%	13,6	1 - 7C	R146	2069 6079	4K7,1%	16,1	1 - 3B
R72	2069 6095	22K,1%	9,6	2 - 7E	R147	2069 6042	150K,1%	4,1	2 - 4F
R73	2069 6040	120R,1%	11,6	3 - 1C	R148	2069 6118	200K,1%	2,1	2 - 4F
R74	2069 6140	ZEROHM	12,5	2 - 5B	R149	2069 6089	12K,1%	2,0	2 - 6A
R75	2069 6079	4K7,1%	2,6	2 - 1C	R150	2069 6022	22R,1%	2,0	2 - 7B
R76	2069 6111	100K,1%	1,6	2 - 1C	R151	2069 6079	4K7,1%	5,0	2 - 2F
R77	2069 6071	2K2,1%	7,5	2 - 5D	R152	2069 6131	680K,1%	3,0	2 - 2F
R78	2069 6069	1K8,1%	13,5	1 - 7C	R153	2069 6065	1K2,1%	6,0	2 - 3F
R79	0000 0000	not used	3,6	2 - 2C	R154	2069 6089	12K,1%	3,0	2 - 6B
R80	2069 6087	10K,1%	4,5	2 - 2C	R155	2069 6089	12K,1%	3,0	2 - 6A
R81	2069 6093	18K,1%	11,6	2 - 5B	R156	2069 6079	4K7,1%	4,0	2 - 2F
R82	2069 6063	1K,1%	5,5	2 - 3D	R157	2069 6099	33K,1%	6,0	2 - 2F
R83	2069 6119	220K,1%	12,5	2 - 5B	R158	2069 6089	12K,1%	3,0	2 - 6B
R84	2069 6038	100R,1%	2,5	2 - 1D	RL1	3415 0001	RELAY (Mute)	1,10	3 - 8B
R85	2069 6089	12K,1%	5,5	2 - 2E					3 - 8C
R86	2069 6047	240R,1%	14,5	1 - 7C					3 - 8D
R87	2069 6096	24K,1%	5,5	2 - 2E	RL2	3415 0001	RELAY (Deem)	3,9	3 - 6C
R88	2069 6103	47K,1%	9,5	2 - 6B					3 - 7B
R89	2069 6093	18K,1%	9,4	2 - 6B					3 - 7D
R90	2069 6081	5K6,1%	5,5	2 - 2E	RP1	2250 0015	22K res pack	11,2	2 - 3B
R91	2069 6060	750R,1%	14,4	1 - 7C					2 - 3C
R92	2069 6007	4R7,1%	5,4	2 - 2E					2 - 4A
R93	2069 6095	22K,1%	12,4	2 - 4B					2 - 4B
R94	2069 6069	1K8,1%	13,4	1 - 7D					2 - 4C
R95	2069 6016	12R,1%	0,4	2 - 1D					2 - 6B
R96	2069 6020	18R,1%	2,4	2 - 1D					2 - 5C
R97	2069 6007	4R7,1%	0,4	2 - 5C	SW1	3412 0020	Tray Switch	7,8	2 - 6B
R98	2069 6025	27R,1%	1,3	2 - 4E	SW2	3413 0048	120/240	18,3	1 - 2B
R99	2069 6026	33R,1%	2,4	2 - 5C					1 - 2C
R100	2069 6079	4K7,1%	8,4	2 - 6C	SW3	3414 0079	NE18 (Mains)	18,0	1 - 1B
R101	2069 6087	10K,1%	12,3	2 - 3B					1 - 1C
R102	2069 6088	11K,1%	1,3	2 - 3E	SW4	3412 0019	CL2P (Open)	9,0	1 - 4E
R103	2069 6046	220R,1%	0,3	2 - 1E	SW5	3412 0019	CL2P (Play)	10,0	1 - 3E
R104	2069 6022	22R,1%	0,4	2 - 4E	SW6	3412 0019	CL2P (Pause)	11,0	1 - 3E
R105	2069 6042	150K,1%	1,4	2 - 3E	SW7	3412 0019	CL2P (Stop)	11,0	1 - 3E
R106	2069 6140	ZEROHM	5,4	2 - 3C	SW8	3412 0021	Swmod (Prev)	12,0	1 - 4E
R107	2069 6113	120K,1%	3,3	2 - 3E	SW9	3412 0021	Swmod (Prog)	13,0	1 - 3E

Ref	Creek code	Desc	@PCB	@CCT	Ref	Creek code	Desc	@PCB	@CCT
SW10	3412 0021	Swmod (Next)	14,0	1 - 4E	R-D			16,8	
SW11	0000 0000	not used	14,0	1 - 4E	V-T			17,8	
SW12	3412 0021	Swmod (Phase)	15,0	3 - 1C	W-E			17,3	
SW13	3412 0021	Swmod (Display)	16,0	1 - 3B	Y-W			18,2	
SW14	3412 0021	Swmod (Digital)	16,0	1 - 4E	+10V			12,4	
TR1	3211 9006	TOROID	17,6	1 - 2B	+12V			15,4	
X1	6561 0002pk	11.2896MHz	14,8	3 - 3D	+12v			11,9	
X2	6561 0034pk	4MHz	12,5	2 - 5B	+15A			8,8	
Z1	2069 6140	ZEROHM	14,11		+24V			10,8	
Z2	2069 6140	ZEROHM	8,11	3 - 2E	+5A			12,8	
Z3	2069 6140	ZEROHM	13,9		+5B			13,10	
Z4	2069 6140	ZEROHM	13,8		+5V			12,4	
Z5	2069 6140	ZEROHM	9,8		-10V			12,3	
Z6	2069 6140	ZEROHM	12,8		-12V			15,8	
Z7	2069 6140	ZEROHM	12,8		-15A			8,8	
Z8	2069 6140	ZEROHM	12,8		-15V			11,11	
Z9	2069 6140	ZEROHM	11,6		-24V			15,9	
Z10	2069 6140	ZEROHM	11,6		-5V			9,11	
Z11	2069 6140	ZEROHM	8,5		-6V			13,3	
Z12	2069 6140	ZEROHM	10,5						
Z13	2069 6140	ZEROHM	3,5						
Z14	2069 6140	ZEROHM	4,5						
Z15	2069 6140	ZEROHM	2,5						
Z16	2069 6140	ZEROHM	8,3						
Z17	2069 6140	ZEROHM	8,2						
Z18	2069 6140	ZEROHM	8,3						
Z19	2069 6140	ZEROHM	4,2						
Z20	2069 6140	ZEROHM	14,1						
ZD1	3646 0359	BZX79-C5V6	13,7						
ZD2	3646 0359	BZX79-C5V6	2,4						
ZD3	3646 0359	BZX79-C5V6	3,3						
ZD4	3646 0361	BZX79-C6V8	13,1						
	6561 0005pk	2 pin lead							
	6561 0007pk	Chassis							
	6561 0008pk	Pressure Plate							
	6561 0009pk	Lift Plate							
	6561 0010pk	Tray							
	6561 0011pk	Tension Spring							
	6561 0012pk	CDM4 support							
	6561 0013pk	Tray washer							
	6561 0014pk	Torx T10 screw							
	6561 0015pk	Suspn. Spring							
	6561 0016pk	Suspn. Grommet							
	6561 0026pk	CDM4 assy.							
	7300 0378	Loader Assy							
	7500 0192	10way Interconn							
	7500 0191	Ground Strap							
	7200 0098	Main PCB complete							
	7200 0099	Disp PCB complete							
	7300 0379	Remote Control							
	4825 0008	Rubber Feet							
	5237 0001	Drawer Front							
	6185 0003	Green Lens							
	4537 0001	Transit screw							
	1532 0007	Heatsink(IC31)							
	1532 0008	Heatsink(IC10,22,28)							
	3639 0002	Clip(IC10,22,28)							
TP1			15,12	1 - 3E					
TP2			0,7	2 - 2C					
TP3			0,7	2 - 2C					
TP4			0,6	2 - 1C					
TP5			0,6	2 - 1C					
TP6			0,6	2 - 1C					
TP7			0,5	2 - 4E					
TP8			0,4	2 - 1C					
TP9			0,4	2 - 1D					
TP10			0,4	2 - 1D					
B-E			14,2						
B-K			13,7						
B-N			16,4						
G-N			16,4						
G-Y			18,3						
O-E			16,1						
O_E			16,1						
P-K			17,2						
					<u>Display PCB</u>				
					C1	2759 6012	220p	0,1	
					C2	2601 0064	22n	0,1	
					C3	2767 6035	22u	0,1	
					C4	2767 6035	22u	7,1	
					CN2	3443 0016	STOCKO-10w	6,0	
					CN3	3443 0016	STOCKO-10w	5,0	
					D1	3646 0340	1N4148	3,0	
					D2	3646 0340	1N4148	5,1	
					D3	3646 0340	1N4148	4,1	
					D4	3646 0340	1N4148	4,1	
					D5	3646 0340	1N4148	4,1	
					D6	0000 0000	not used	5,1	
					D7	0000 0000	not used	4,1	
					IC1	6561 0024pk	U3090	4,1	
					LED1	3554 1008	GREEN	6,1	
					OPIC1	6186 0001	IS1U60L	6,0	
					Q1	3630 2042	BC548	7,1	
					R1	2069 6140	ZEROHM	7,2	
					R2	2069 6007	4R7, 1%	0,0	
					R3	2069 6095	22K, 1%	3,0	
					R4	2069 6095	22K, 1%	3,0	
					R5	2069 6095	22K, 1%	5,0	
					R6	2069 6007	4R7, 1%	1,0	
					R7	2069 6103	47K, 1%	2,0	
					R8	2069 6115	150K, 1%	2,0	
					R9	2069 6079	4K7, 1%	3,0	
					R10	2069 6054	470R, 1%	2,0	
					R12	2069 6079	4K7, 1%	6,2	
					R13	2069 6079	4K7, 1%	6,1	
					R14	2069 6007	4R7, 1%	7,1	
					R15	2069 6103	47K, 1%	7,1	
					R16	2069 6050	330R,1%	7,1	
					V1	6561 0025pk	VF_DISPLAY	5,2	
					...	6561 0006pk	Support	5,2	
					ZD1	3646 0369	BZX79-C15V	2,0	

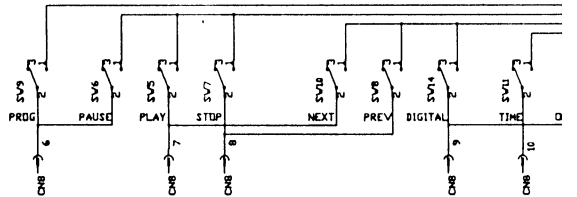
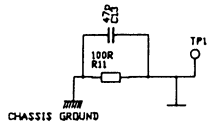
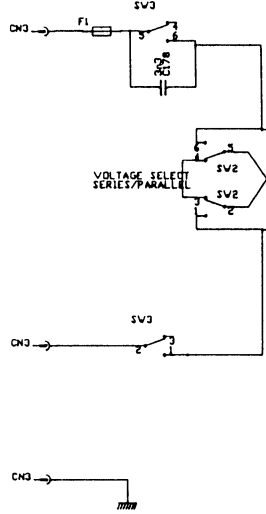
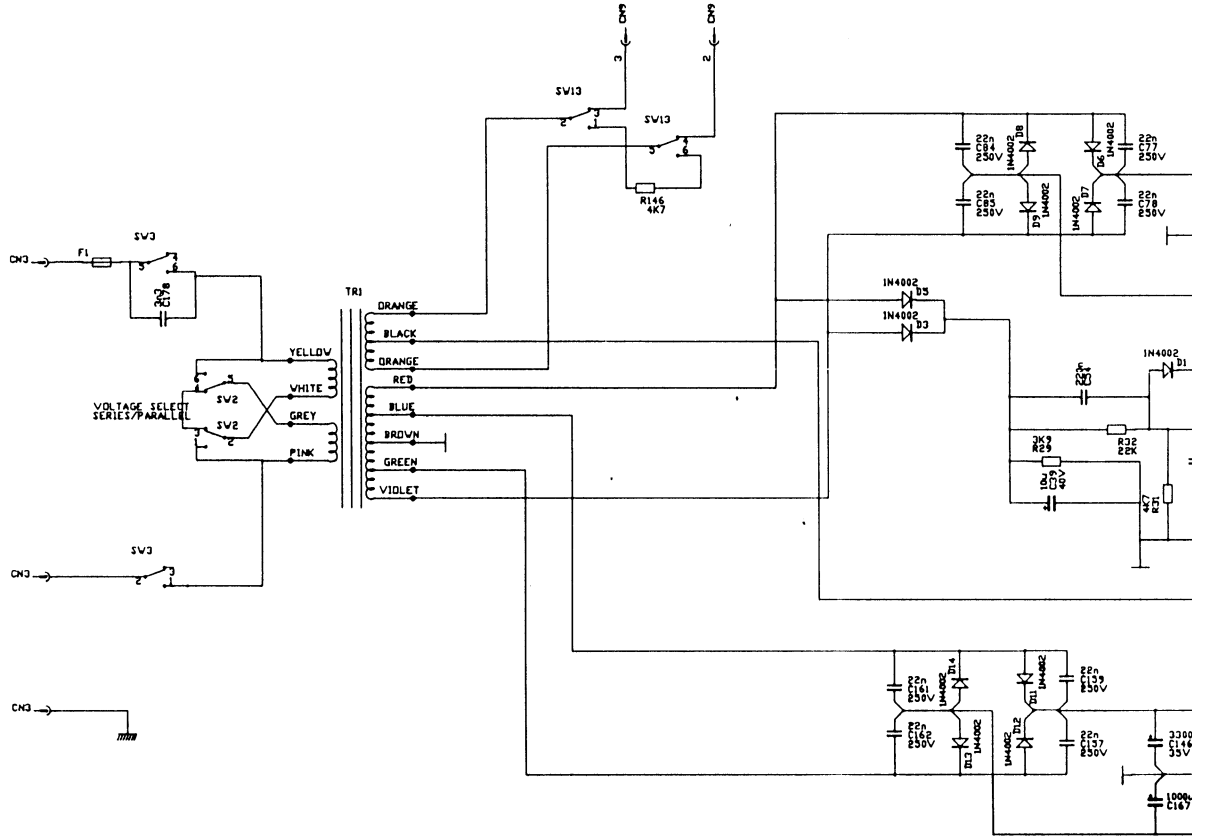

The contents, information and copyright of this document are the sole property of Creek Audio Systems and must not be published, applied or copied without the express knowledge & permission of the owners.

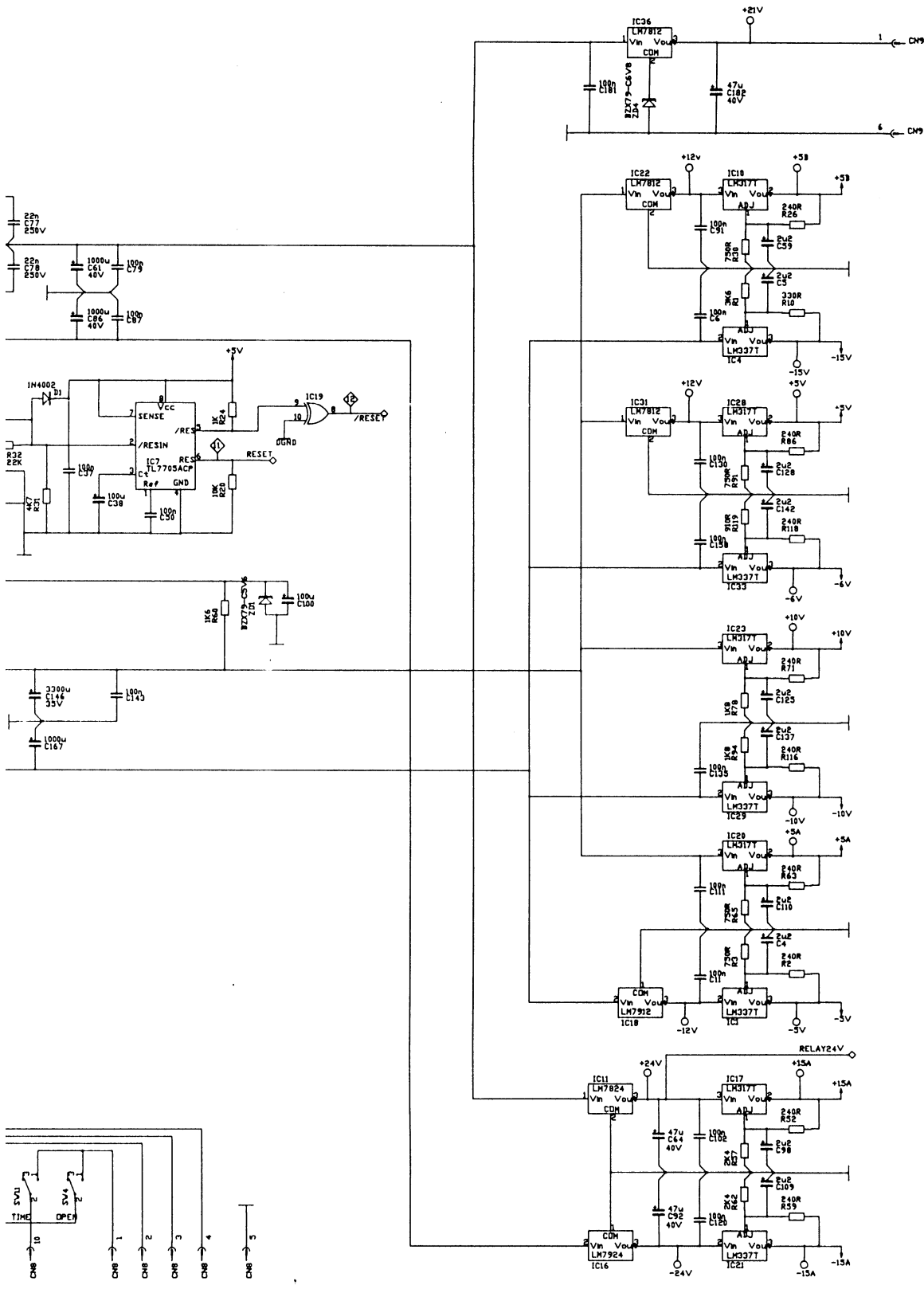

ISSUE 1	01/12/91	ISSUE 4		ISSUE 7		DrawnK Rodgerson
2	01/03/92	3		8		Checked
3		4		9		Approved
TITLE CD60 POWER SUPPLY						1 of 3 A1

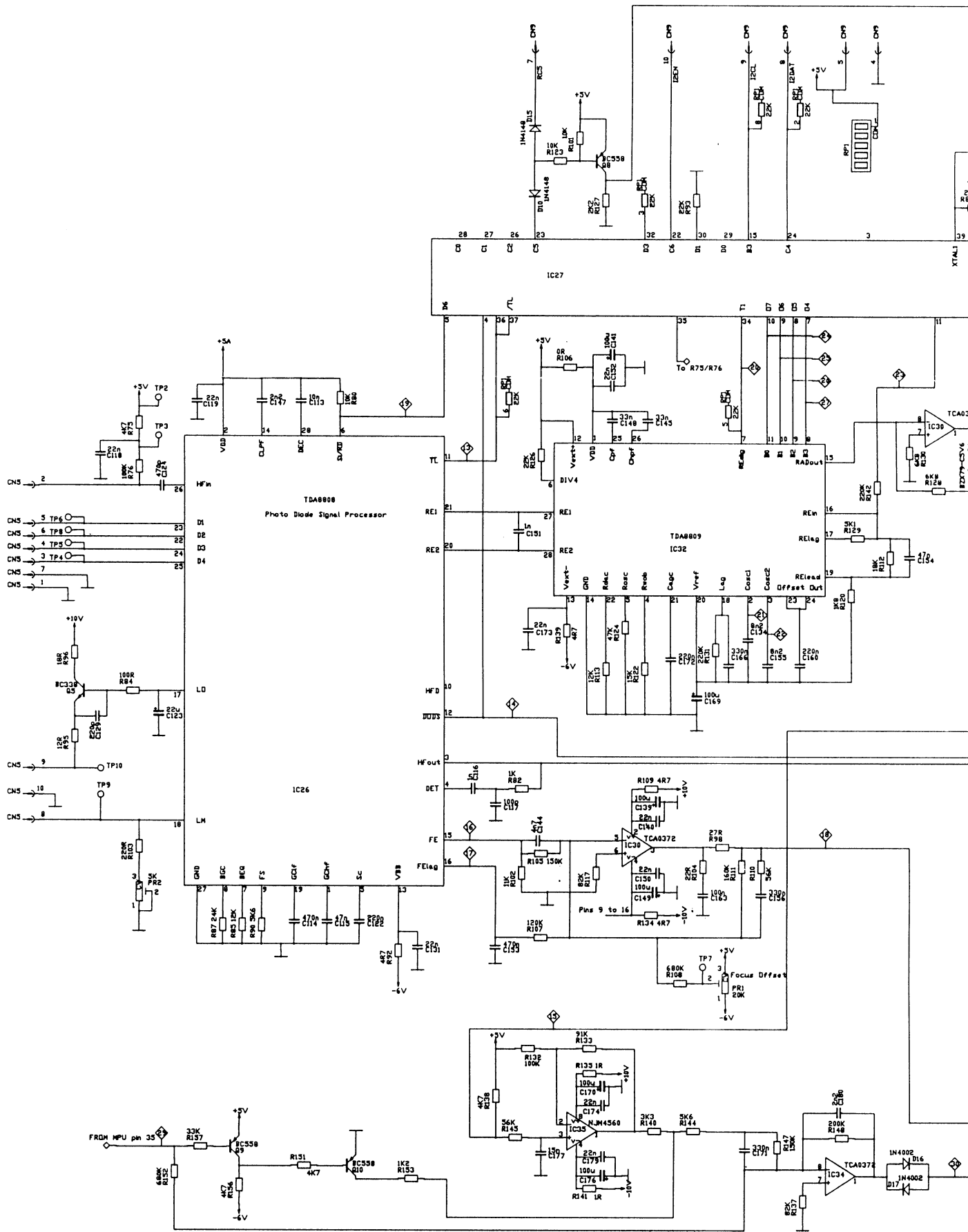

The contents, information and copyright of this document are the sole property of Creek Audio Systems and must not be published applied or copied without the express knowledge & permission of the owners.

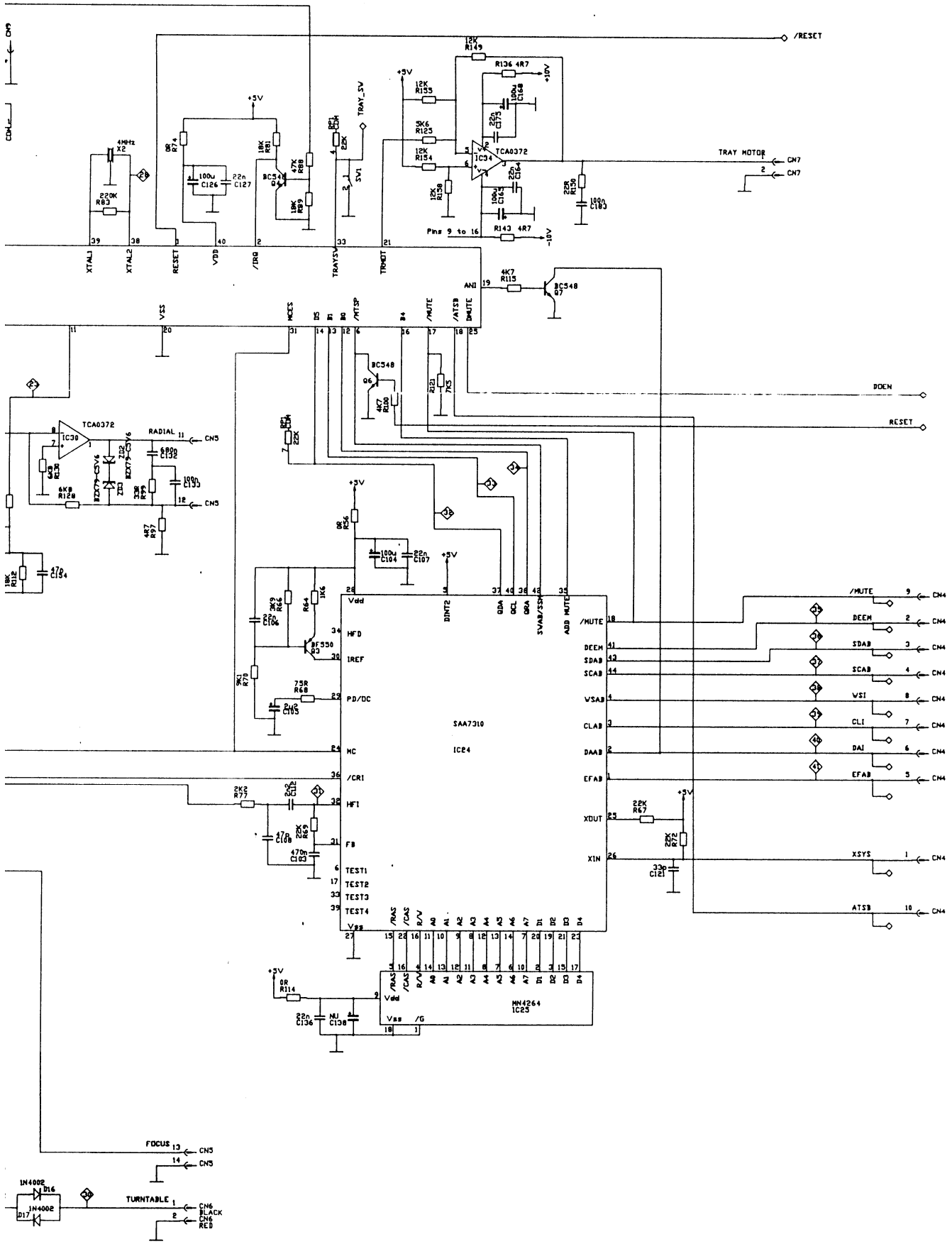

ISSUE 1 01/12/91	ISSUE 4	ISSUE 7	Drawn K Rodgerso
2 01/03/92	5	8	Checked
3	6	9	Approved
TITLE CD60 SERVO/DECODE CCT			2 OF 3 A1

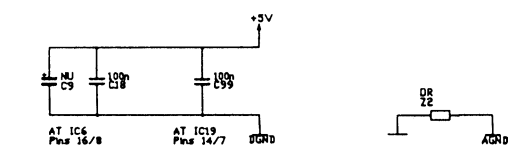
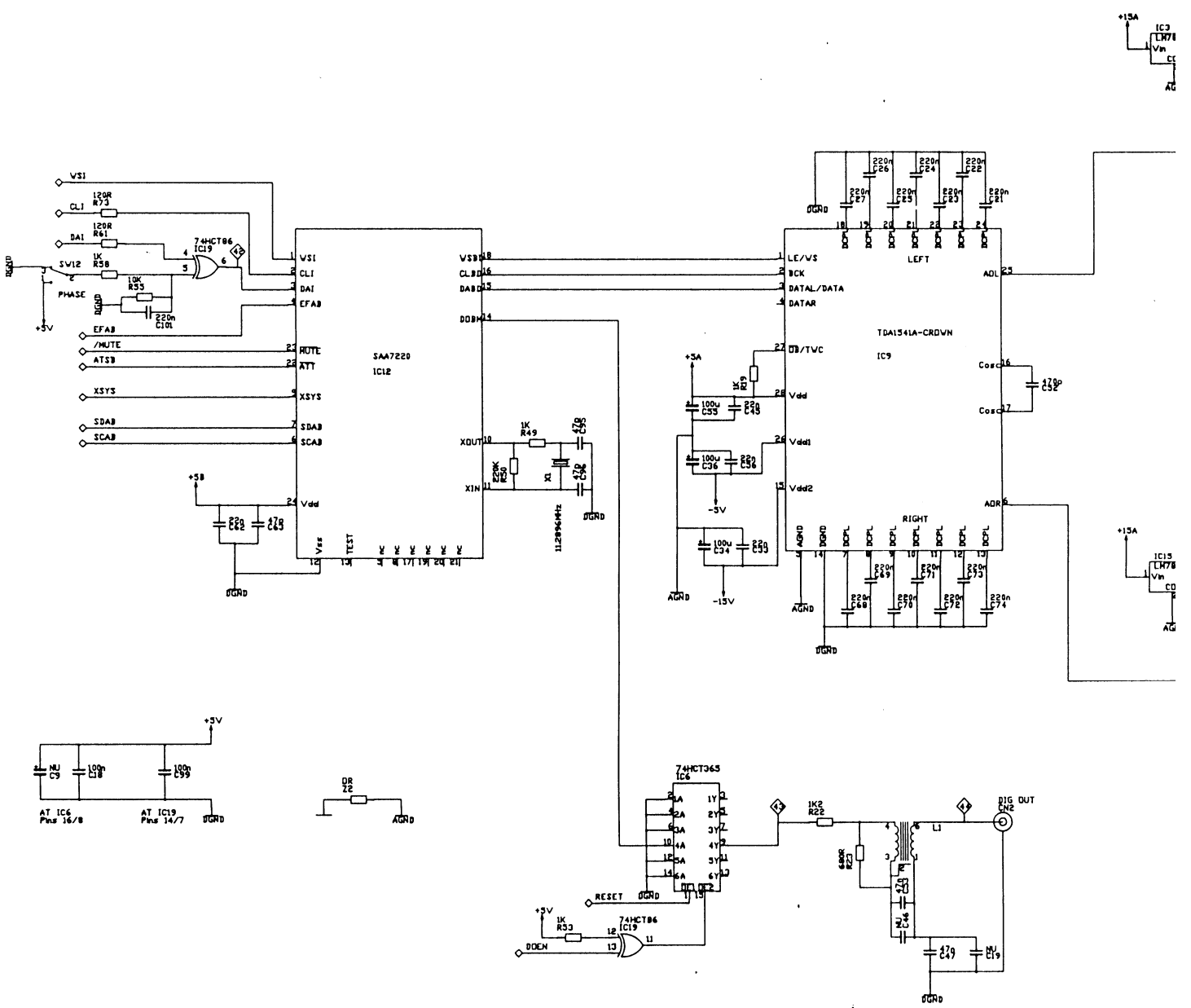

The contents, information and copyright of this document are the sole property of Creek Audio Systems and must not be published, applied or copied without the express knowledge & permission of the owners.

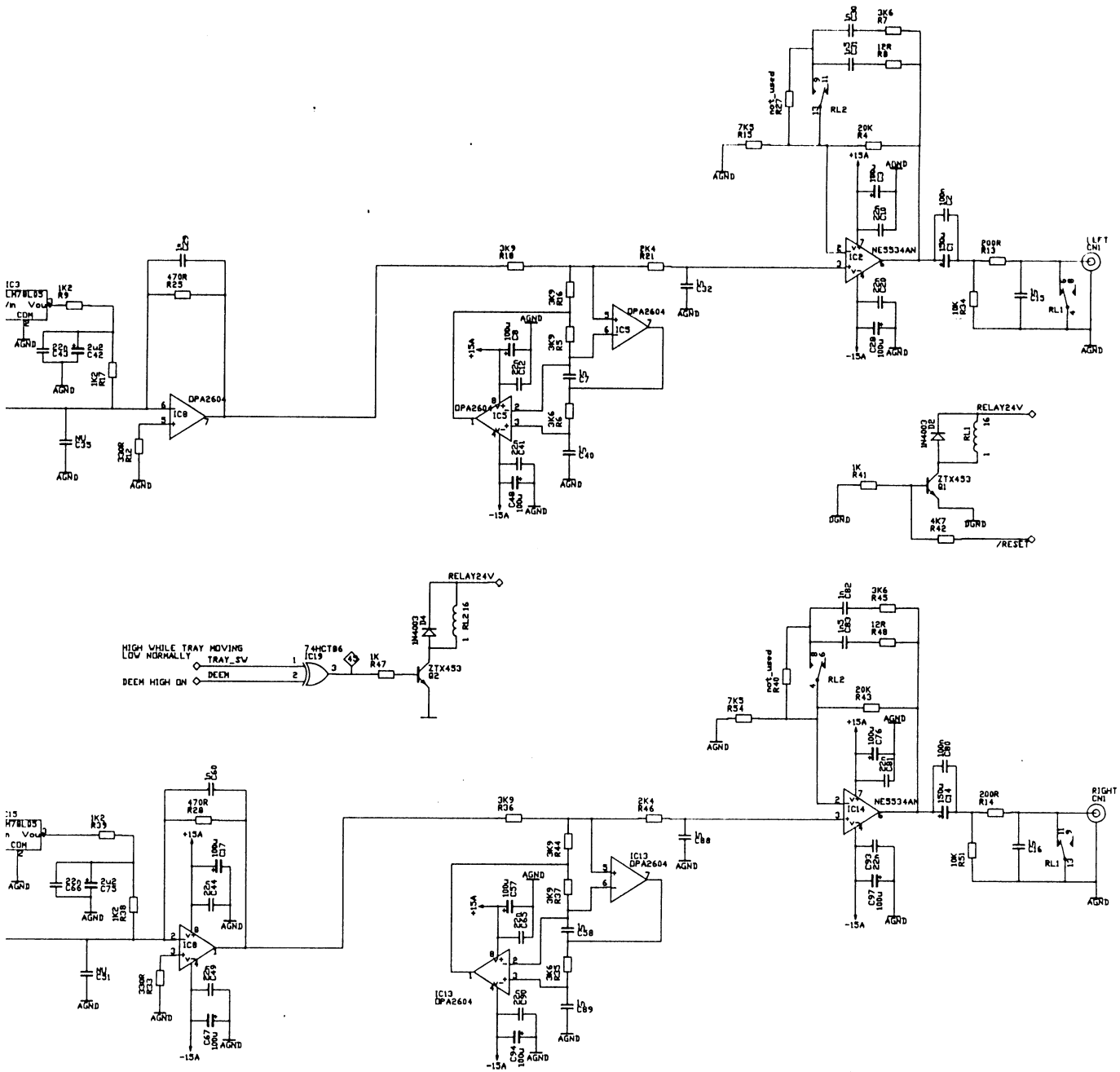

ISSUE 1 01/12/91	ISSUE 4	ISSUE 7	Drawn K Rodgersc
2 01/03/92	5	8	Checked
3	6	9	Approved
TITLE CD60 DAC			3 of 3 A1

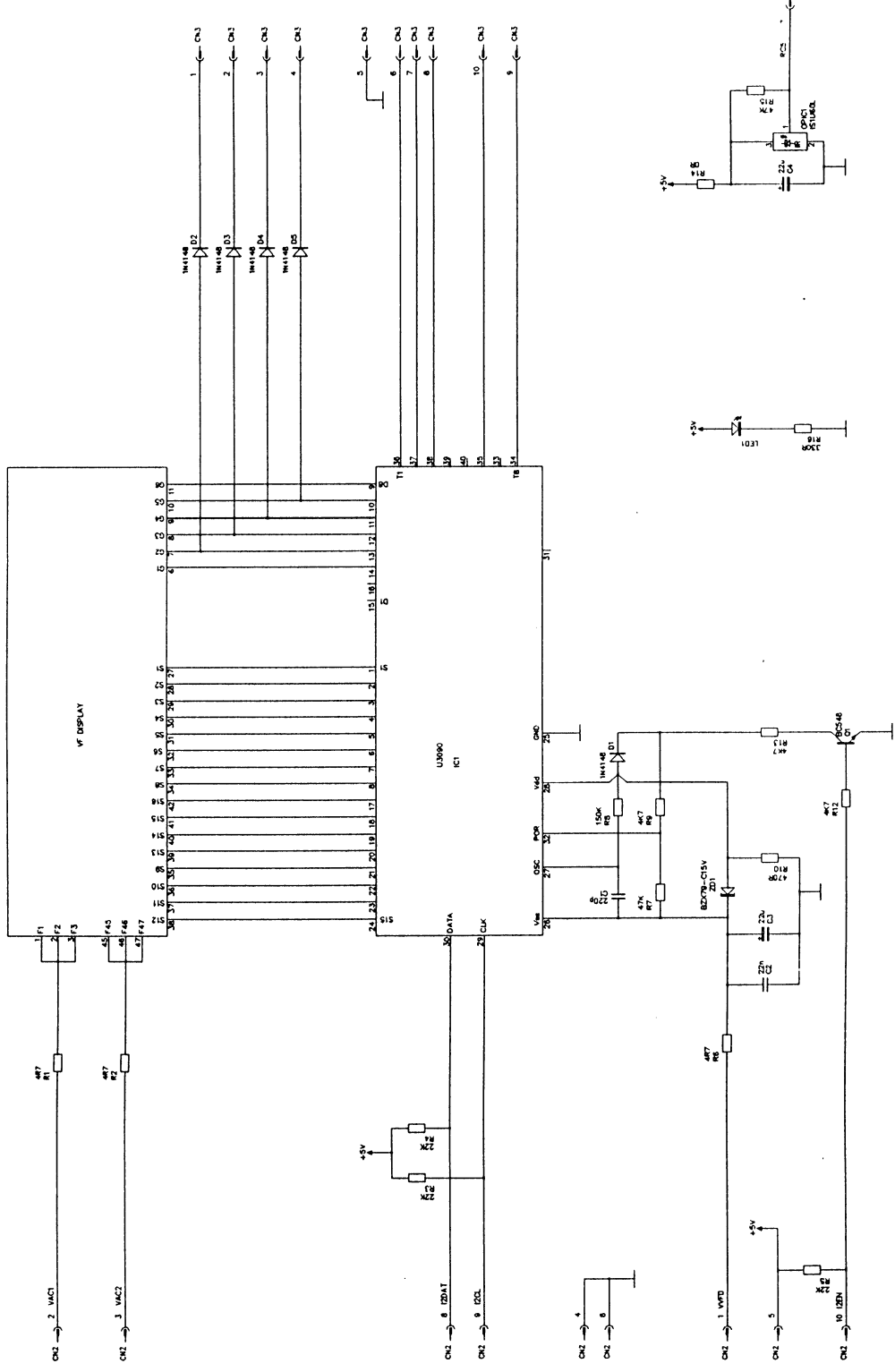

* NOTE: CH1, R11 NOT USED

This document is the intellectual property of Cree. All rights are reserved. No part of this document may be reproduced, stored in a retrieval system, or transmitted, in any form or by any means, without prior written permission from Cree.

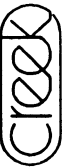

1	2	3	4	5	6	7
01/12/91	01/03/92					
Drawn K. Rodger	Checked	Approved				
1	1	1	1	1	1	1
A2	A2	A2	A2	A2	A2	A2

TITLE: CD60 DISPLAY

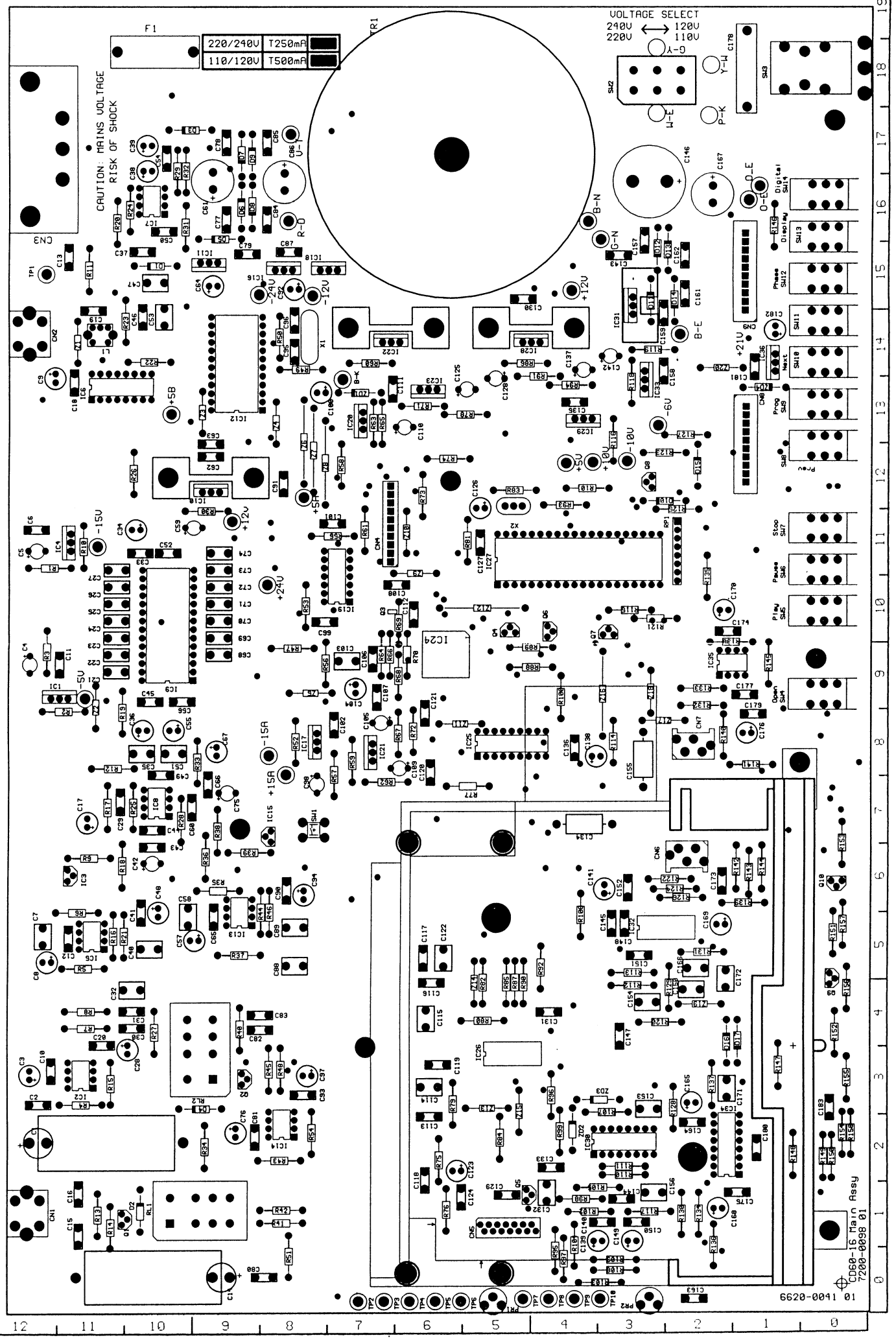

CAUTION: MAINS VOLTAGE
RISK OF SHOCK

VOLTAGE SELECT
290V ← 120V
220V → 110V

220/240V	T250mF
110/120V	T500mF

6628-0091 01

CD60-16 Main Assy
7200-0098 01

19
18
17
16
15
14
13
12
11
10
9
8
7
6
5
4
3
2
1
0

12
11
10
9
8
7
6
5
4
3
2
1
0

Part No. 0042-01
6620 DIS PLAY

7

6

5

4

3

2

1

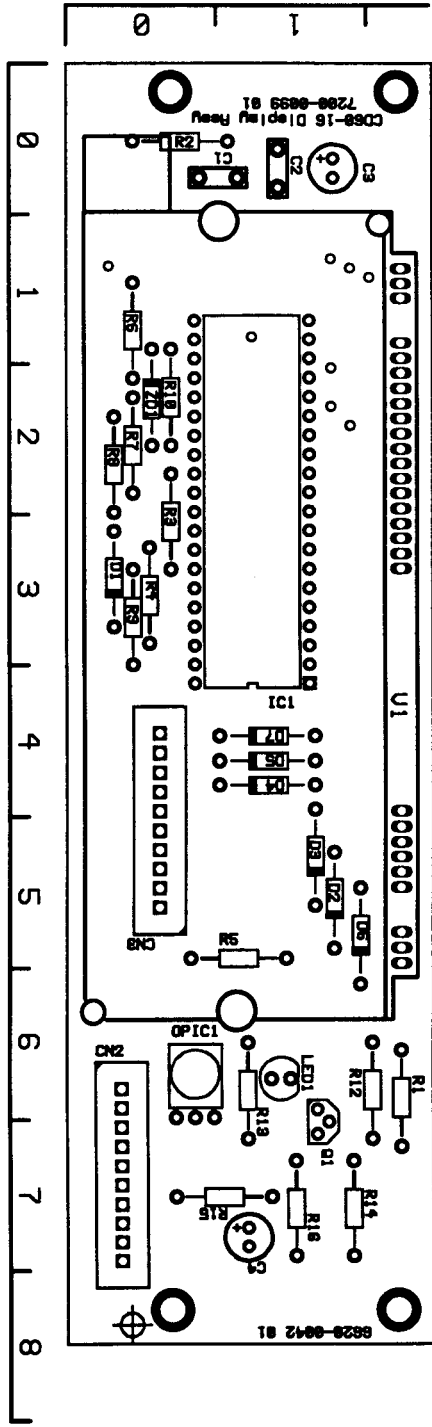

DATE	ISSUE	BY	CHKD
1-12-91	1		
	2		
	3		
	4		
	5		
	6		
	7		
	8		
	9		
	10		

TITLE	DATE	BY	CHKD

8829-8812 01

