

Service Manual

DVD PLAYER

MODEL: DG-K511S
DG-K513S
DG-K516S

✓ **Caution :**

In this Manual, some parts can be changed for improving, their performance without notice in the parts list. So, if you need the latest parts information, please refer to PPL(Parts Price List) in Service Information Center.

January. 2006

CONTENTS

CONTENTS

SPECIFICATIONS.....	2
CIRCUIT OPERATIONAL DESCRIPTION.....	3
VOLTAGE CHARTS.....	13
CIRCUIT DIAGRAM.....	14
PCB CIRCUIT BOARD.....	26
WAVEFORMS.....	36
TROUBLE SHOOTING.....	43
INSTRUMENT DISASSEMBLY.....	48
PARTLIST.....	55

SPECIFICATIONS

Laser		wavelength 650nm
Video		PAL/AUTO/NTSC
Frequency response		20Hz ~ 20KHz (± 1 dB)
Signal/noise ratio		≥ 90 dB
Channel separation		≥ 85 dB (1KHz)
Dynamic range		≥ 80 dB (1KHz)
Output Audio	Analog	output level : 2.0 + 0/-0.2Vrms (Load impedance : 1,0K Ω)
	Digital	output level : 0.5 \pm 0.1Vp-p (Load impedance : 75 Ω)
Output Video	Composite	output level : 1.0 \pm 0.1Vp-p (Load impedance : 75 Ω , imbalance, negative polarity)
	S-video	output level : brightness(Luma) 1.0 \pm 0.1Vp-p Chromaticity (Color) 0.286 \pm 20% (Load impedance : 75 Ω)
	Component	Y: 1Vp-p, Pb/Pr: 0.7Vp-p (Load impedance : 75 Ω)
Power		100-240V~, 50Hz~60Hz 12W
Dimensiones	Body (W x H x D)	430 x 38 x 245 mm
	Packing	510 x 88 x 305 mm
Weight (Gross / Net)		2.9Kg / 2.2Kg

Notes : Design and specifications in this instruction manual are subjected to change without prior notice to improve quality and function.

DVD Audio output standards

Output	Disc type		
	DVD	VIDEO-CD	CD
Analogue Audio output	48/96KHz sampling	44.1KHz sampling	44.1KHz sampling
Digital Audio output	48KHz sampling	44.1KHz sampling	44.1KHz sampling

CIRCUIT OPERATIONAL DESCRIPTION

DVD Module

1. Summary

DVD One Board consists of: Loader part that reads and transmits audio and video data saved at Optic Discs (DVD, CD-DA, VCD, CD-R) to MPEG Decoder part; MPEG Decoder part, which, by decoding and encoding data received from the Loader, produces analog signals; and u-Com that controls the overall system including the loader and MPEG decoder.

2. How Does it Operate

Insert the power cord and then power transmitted to each IC, and the SET will be the STAND-BY status which requires the least power for input the front panel key, input the STAND BY/ ON key, extinguished the LED. Once the Power On key is entered, u-Com recognizes it and initiates each chipset, performs sequential algorithms such as determining whether the disc is in or not, and if in, what type of disc is loaded.

Through this process, it can read disc data before transmitting it to the MPEG Decoder. The MPEG Decoder will then decode and encode such data before generating the final analog audio and video signal outputs.

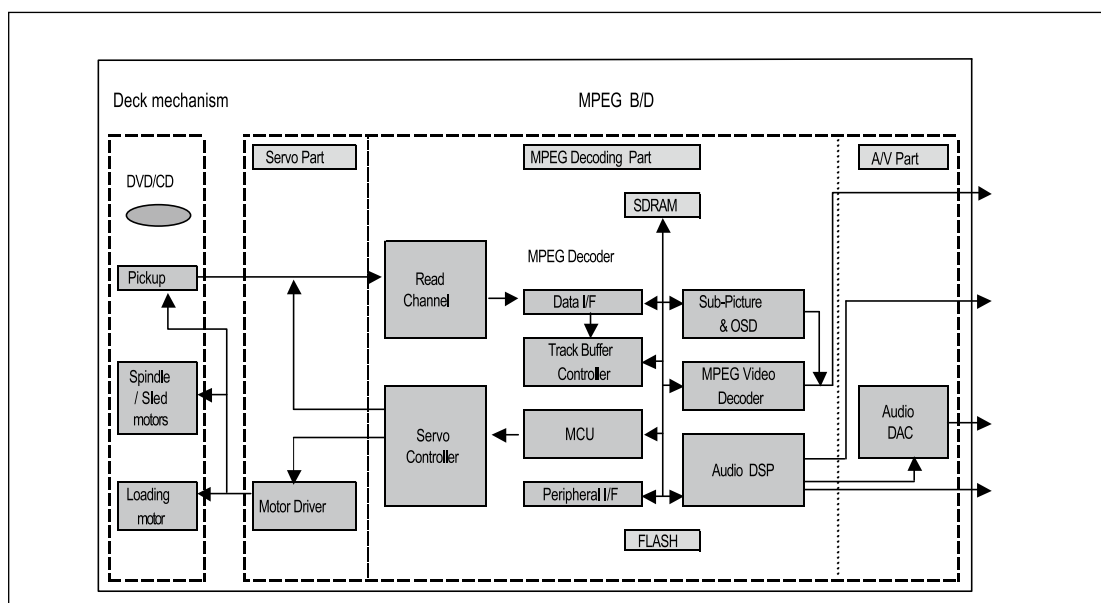

DVD-MODULE Block Diagram

CIRCUIT OPERATIONAL DESCRIPTION

3. Loader Part

The loader which read the data of audio/video from optic disc and transfer them to MPEG decoder can be divided into Deck total DVD assay(in a short term, Mecha) and Servo. Mecha mounts with the optical pick-up which allows reading the signal of a disc using laser beam and makes it operates and consists of the deck mechanism which allows loading a disc and reading the data. Servo is a sort of circuit which allows operating the loader and recovering the data and consists of Motor Drive IC operating the spindle, the sled, the loading motor.

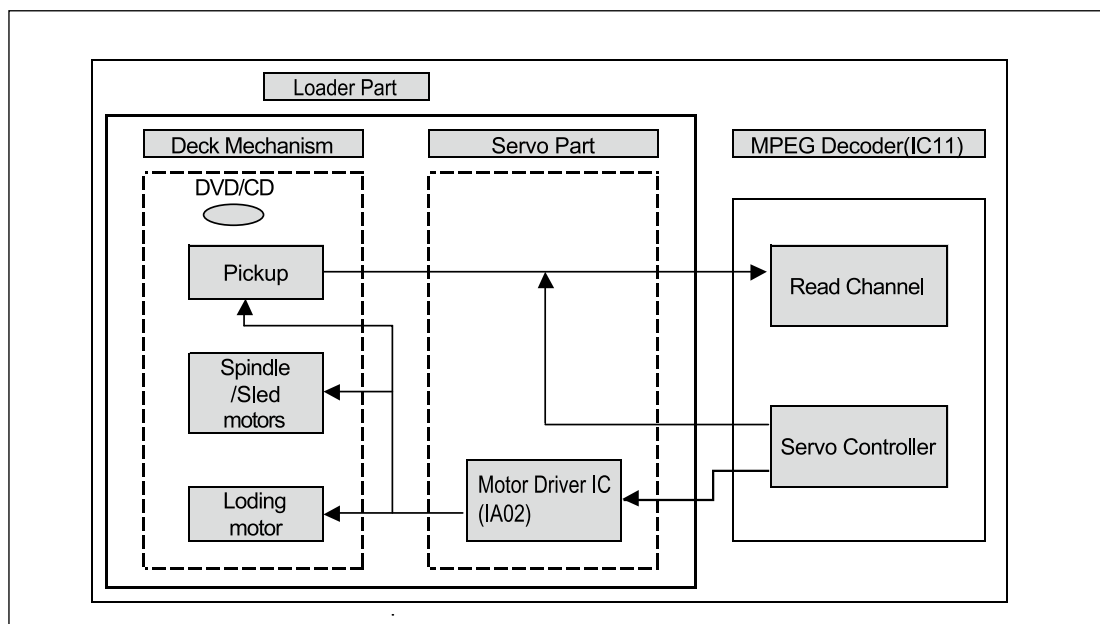

Loader Block Diagram

CIRCUIT OPERATIONAL DESCRIPTION

1) Motor Drive IC: AT5668S

The AT5668S is a 5-channel BTL driver IC for driving the motors and actuators in products such as CD-ROM/DVD-ROM/DVD-Player drives. Two of the channels use current feedback to minimize the current phase shift caused by the influence of load inductance. Driver IC generates the focus signal and the tracking signal for pick-up actuator, the sled signal for feed, spindle signal and the load signal for opening and closing of the tray. The focus signal, the tracking signal, the sled signal and the spindle signal are input into each relaxant port of the drive IC (in the order of No. 26 pin, 23, 4, and 1) and set the gain amplification and the center voltage through the internal OP-AMP and drive on both sides and then the focus signal and the tracking signal will be output as VOFC+, VOFC- and VOTK+, VOTK- on actuator, the sled signal and the spindle signal will be output as VOSL+, VOSL- and VOLD+, VOLD- on each motor. For the load signal the input opening/closing signal is output as VOTR+, VOTR- through the loading PRE FWD REV circuit.

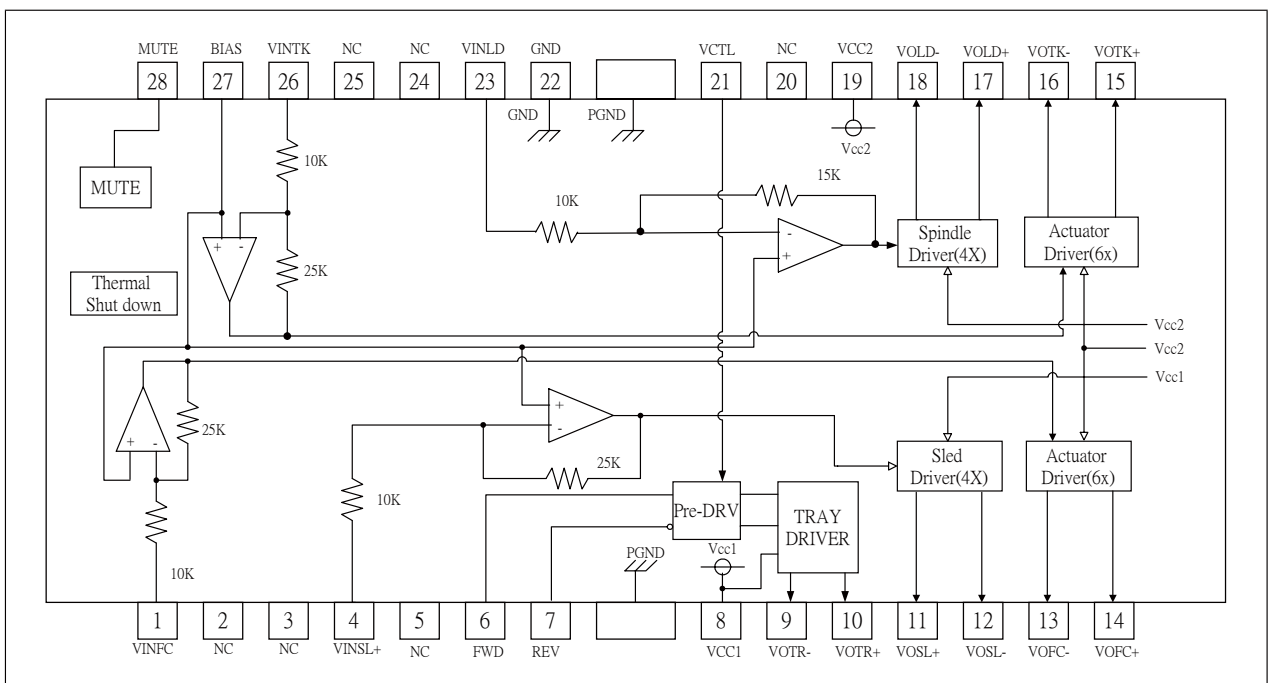

Motor Drive IC (AT5668S) Block Diagram

CIRCUIT OPERATIONAL DESCRIPTION

MPEG Decoder

The signal read from DVD disc is output into the RF signal and Servo related signal through the RF IC and they are input into the MPEG decoder and processed the MPEG decoding and divided into video/audio signal. The video signal is output into the analog audio signal through the built-in encoder block and also the audio signal into the audio DAC through the audio decoder block.

MPEG decoder consists of existing MPEG-2 decoder and single chip combined the digital signal processing part which is the core technology of DVD player with the Servo controller.

1) DVD Servo And MPEG-2 Decoder : MT1389

MediaTek MT1389 is a DVD player system-on-chip (SOC) which incorporates advanced features like high quality TV encoder and state-of-art de-interlace processing. The MT1389 enables consumer electronics manufacturers to build high quality, cost-effective DVD players, portable DVD players or any other home entertainment audio/video devices.

Based on MediaTek's world-leading DVD player SOC architecture, the MT1389 is the 3rd generation of the DVD player SOC. It integrates the MediaTek 2nd generation front-end analog RF amplifier and the Servo/MPEG AV decoder.

The progressive scan of the MT1389 utilized advanced motion-adaptive de-interlace algorithm to achieve the best movie/video playback. It also supports a 3:2 pull down algorithm to give the best film effect. The 108MHz/12-bit video DAC provides users a whole new viewing experience.

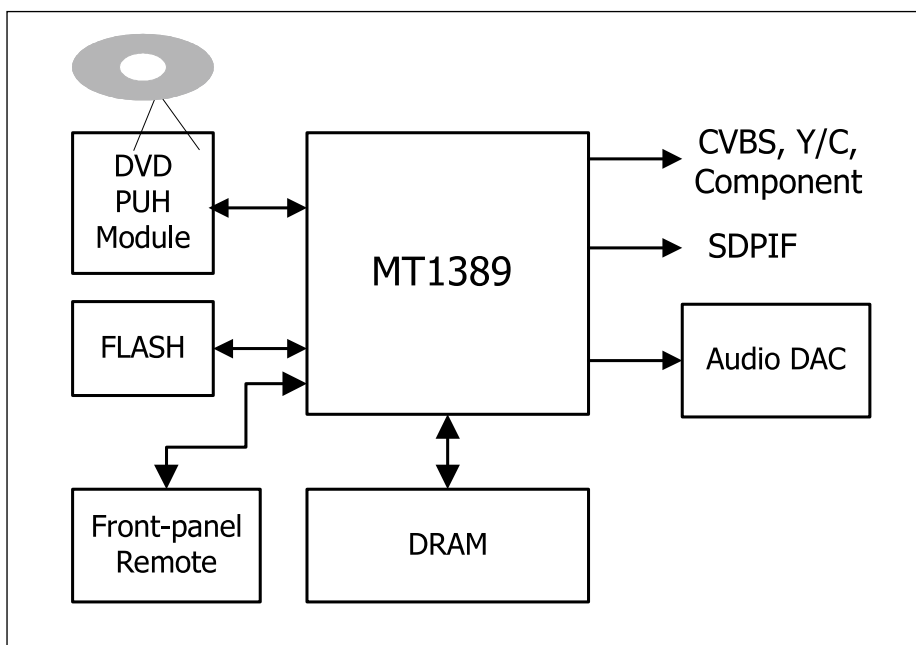

DVD Player System Diagram

CIRCUIT OPERATIONAL DESCRIPTION

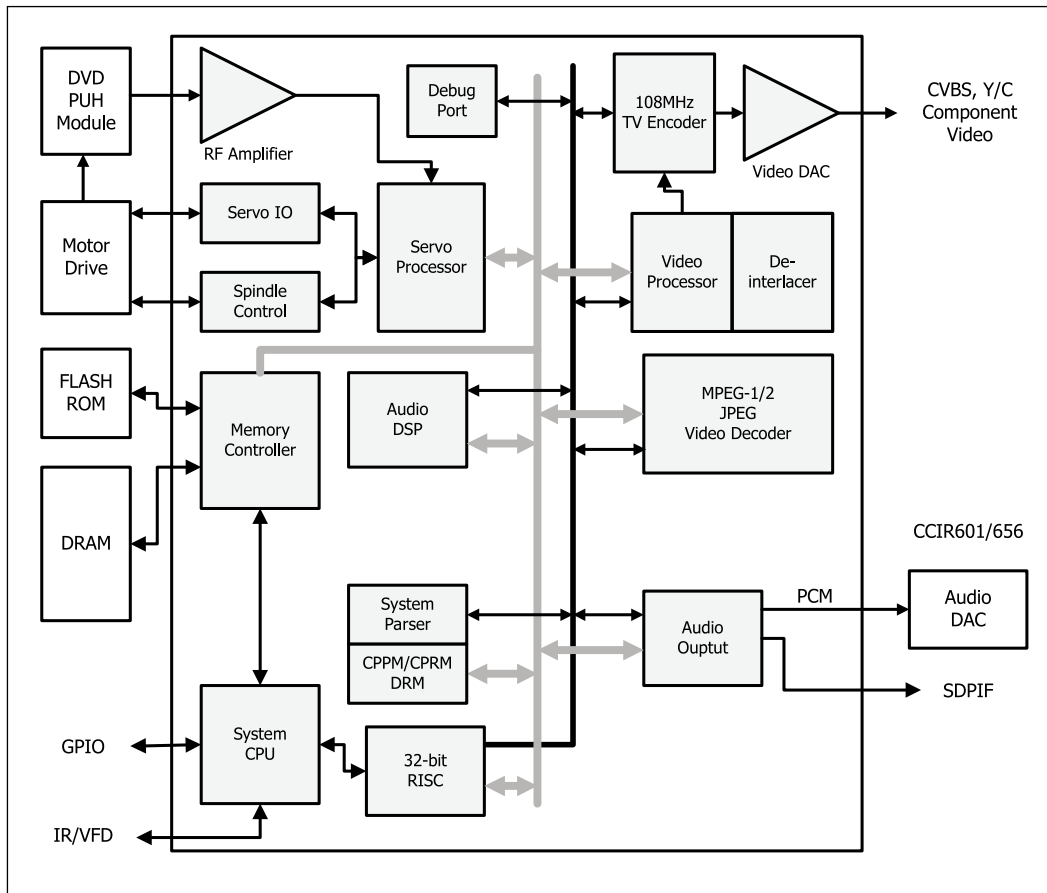

MT1389 Functional Block Diagram

CIRCUIT OPERATIONAL DESCRIPTION

2) Flash Memory : ES29LV160DB-70TG

Description

The ES29LV160 is a 16 megabit, 3.0 volt-only flashmemory device, organized as 2M x 8 bits (Bytemode) or 1M x 16 bits (Word mode) which is config-urable by BYTE#. Four boot sectors and thirty onemain sectors are provided : 16Kbytes x 1, 8Kbytes x 2, 32Kbytes x 1 and 64Kbytes x 31. The device ismanufactured with ESI's proprietary, high performance and highly reliable 0.18um CMOS flashtechnology. The device can be programmed orerased in-system with standard 3.0 Volt Vcc supply(2.7V-3.6V) and can also be programmed in stan-dard EPROM programmers. The device offers min-imum endurance of 100,000 program/erase cyclesand more than 10 years of data retention.

The ES29LV160 offers access time as fast as 70nsor 90ns, allowing operation of high-speed microprocessors without wait states. Three separate controlpins are provided to eliminate bus contention : chipenable (CE#), write enable (WE#) and outputenable (OE#).

All program and erase operation are automaticallyand internally performed and controlled by embed-ded program/erase algorithms built in the device.The device automati-cally generates and times thenecessary high-voltage pulses to be applied to thecells, performs the verification, and counts the number of sequences. Some status bits (DQ7, DQ6 andDQ5) read by data# polling or toggling betweenconsecutive read cycles provide to the users theinternal status of program/erase operation: whetherit is successfully done or still being progressed.

The ES29LV160 is completely compatible with theJEDEC standard command set of single power sup-ply Flash. Commands are written to the internalcommand register using standard write timings ofmicroprocessor and data can be read out from thecell array in the device with the same way as used inother EPROM or flash devices.

CIRCUIT OPERATIONAL DESCRIPTION

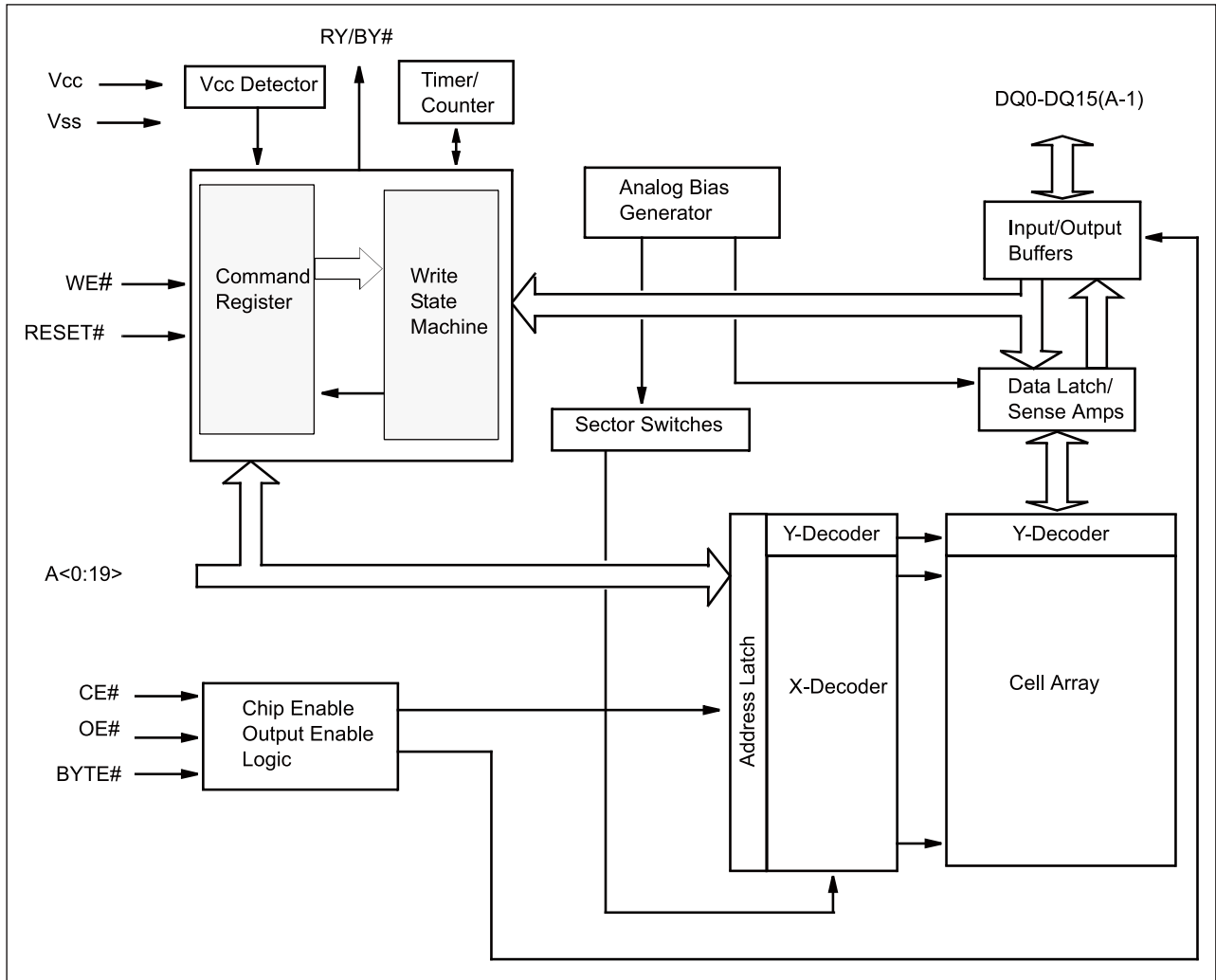

FLASH ES29LV160 Block Diagram

CIRCUIT OPERATIONAL DESCRIPTION

3) EEPROM : AT24C16A

This stores the information related to setup of DVD menus. This can read and write the optional information such as OSD, voice, language option after function for subtitle etc, the aspect or method of TV display, video option like display function and audio, screen saver, parental function through the I2C transmission method.

Description

The AT24C16A provides 16384 bits of serial electrically erasable and programmable read only memory (EEPROM) organized as 2048 words of 8 bits each. The device is optimized for use in many industrial and commercial applications where low power and low voltage operation are essential. The AT24C16A is available in space saving 8-lead PDIP, 8-lead JEDEC SOIC, 8-lead MAP and 8-lead TSSOP packages and is accessed via a 2-wire serial interface. In addition, the entire family is available in 2.7V (2.7V to 5.5V) and 1.8V (1.8V to 5.5V) versions.

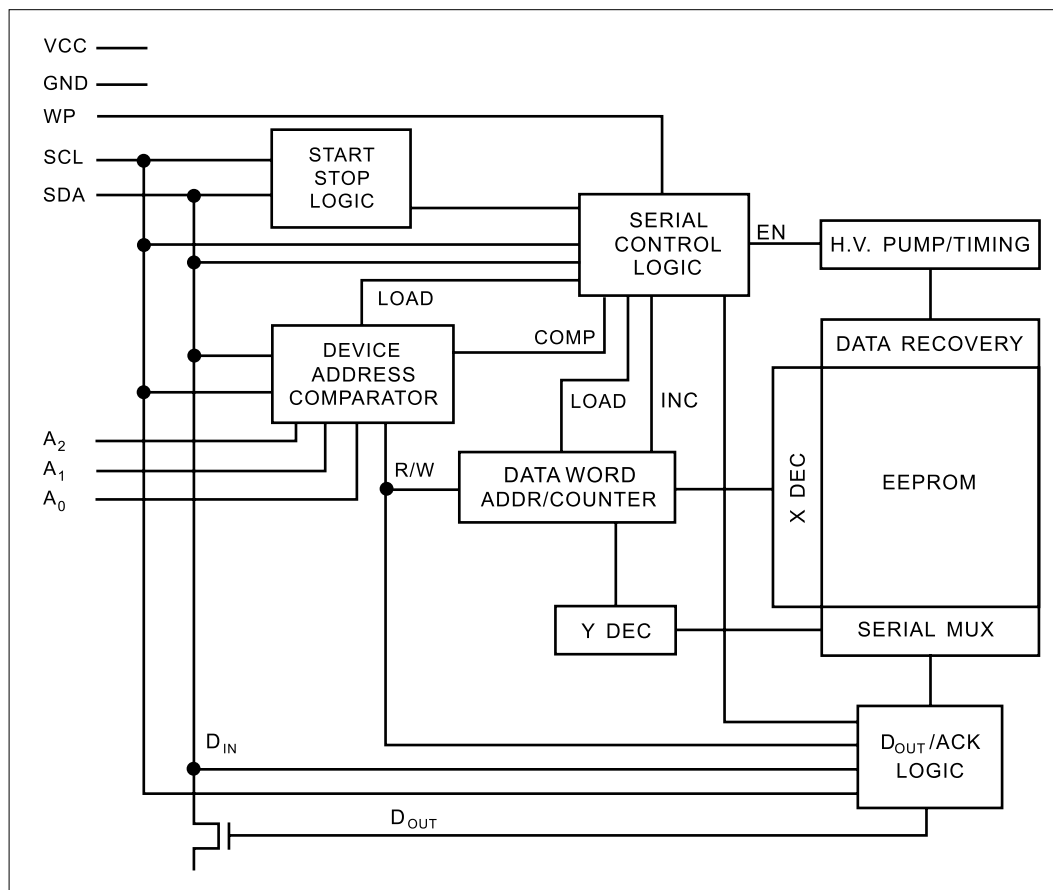

EEPROM AT24C16A Block Diagram

CIRCUIT OPERATIONAL DESCRIPTION

4) SDRAM : AW39S2016-7

Description

The AW39S2016-7s organized as 2-bank x 1,048,576-word x 16-bit(2Mx16), fabricated with high performance CMOS technology, Synchronous design allows precise cycle control with the use of system clock I/O transactions are possible on every clock cycle. Range of operating frequencies, programmable burst length and programmable latencies allow the same device to be useful for a variety of high bandwidth, high performance memory system applications.

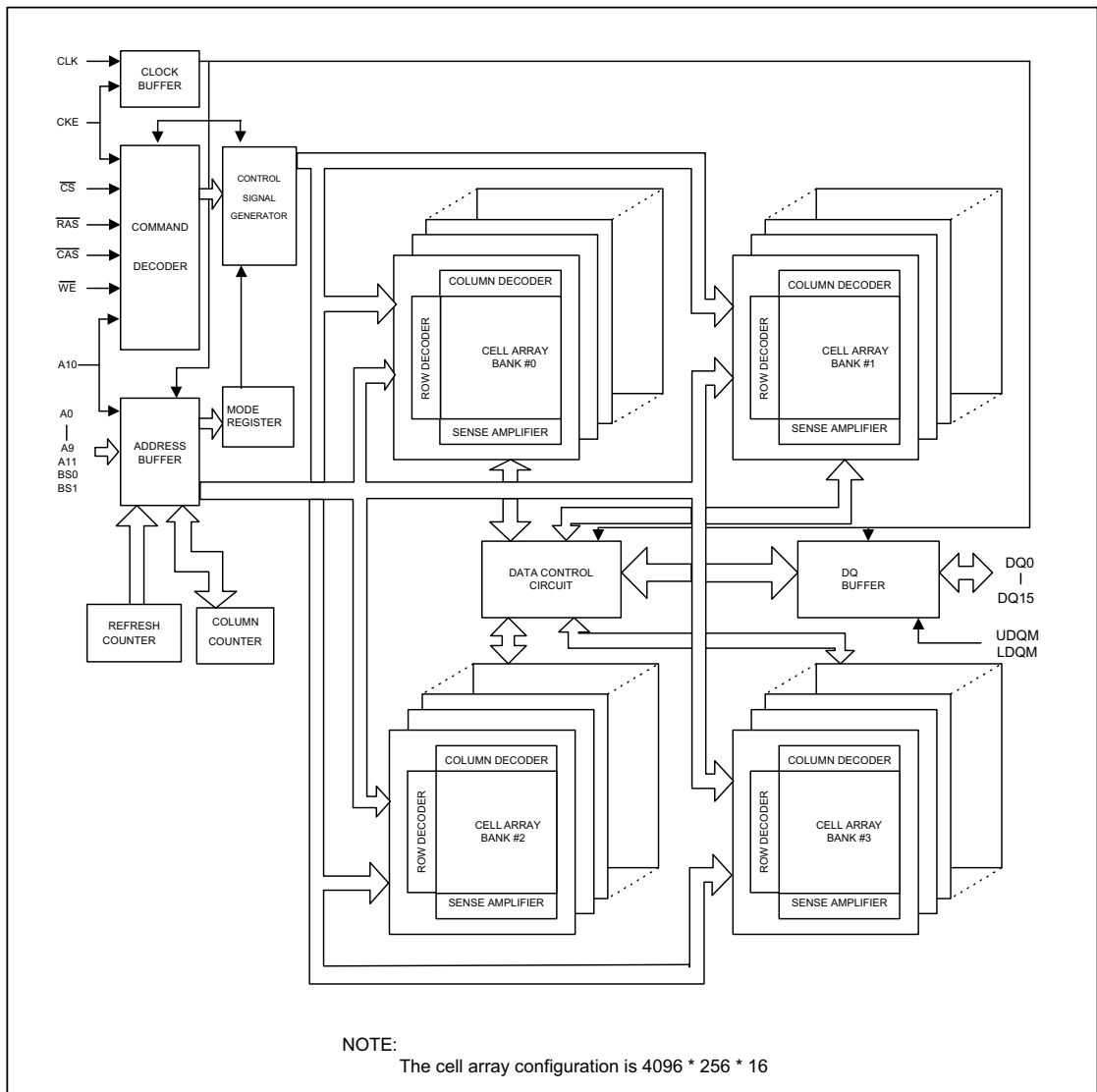

SDROM AW39S2016-7 Block Diagram

CIRCUIT OPERATIONAL DESCRIPTION

5) DAC : CS4360

Description

The CS4360 is a complete 6-channel digital-to-analog system including digital interpolation, fourth-order delta-sigma digital-to-analog conversion, digital deemphasis, volume control, channel mixing and analog filtering. The advantages of this architecture include: ideal differential linearity, no distortion mechanisms due to resistor matching errors, no linearity drift over time and temperature and a high tolerance to clock jitter.

The CS4360 accepts data at audio sample rates from 4kHz to 200kHz, consumes very little power and operates over a wide power supply range. These features are ideal for cost-sensitive, multi-channel audio systems including DVD players, A/V receivers, set-top boxes, digital TVs and VCRs, mini-component systems, and mixing consoles.

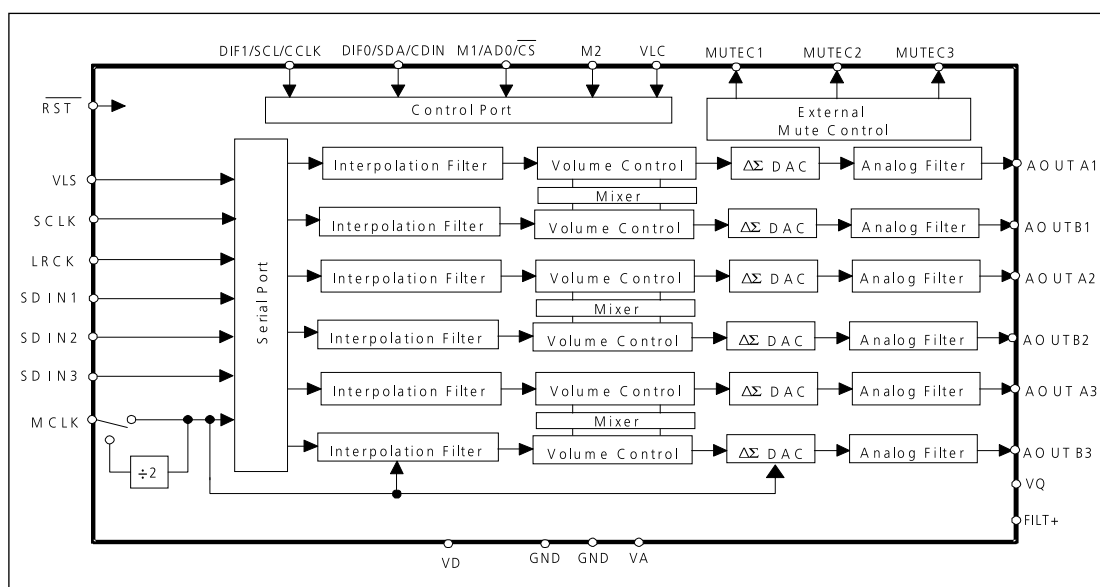

DAC CS4360 Block Diagram

VOLTAGE CHARTS

Power board output voltage

J1

Pin number	1	2	3	4	5	6	7	8	9
Output voltage	GND	S5V	3.3V	D5V	GND	A5V	GND	+12V	-12V

J2

Pin number	1	2	3	4	5	6
Output voltage	SW	F-	F+	GND	-24V	STB5V

Decode board input voltage

CN1

Pin number	1	2	3	4	5	6	7	8	9
Output voltage	GND	S5V	3.3V	D5V	GND	A5V	GND	+12V	-12V

2. DECODE BOARD SCHEMATIC DIAGRAM

1) INDEX SCHEMATIC DIAGRAM

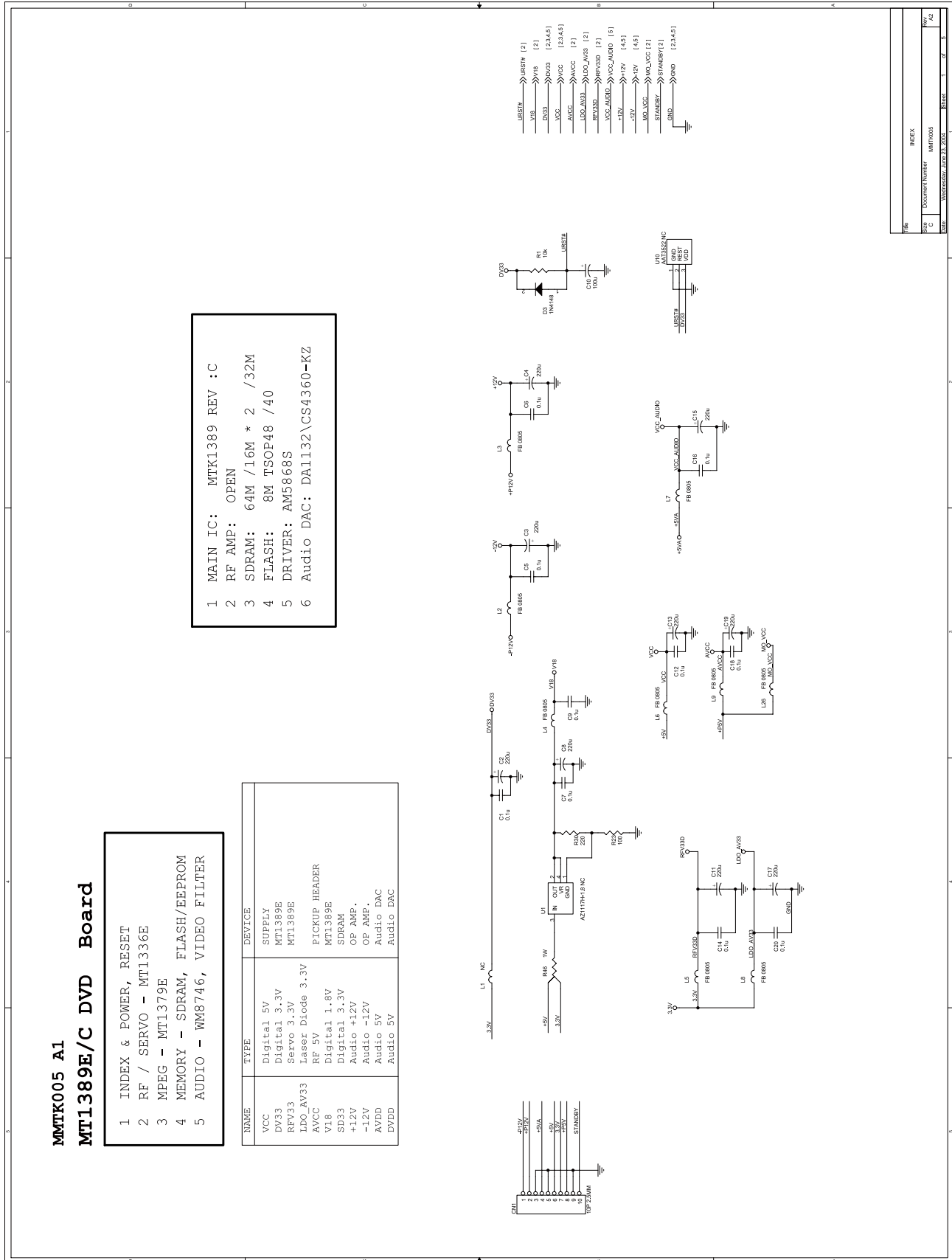

3) SDRAM & FLASH SCHEMATIC DIAGRAM

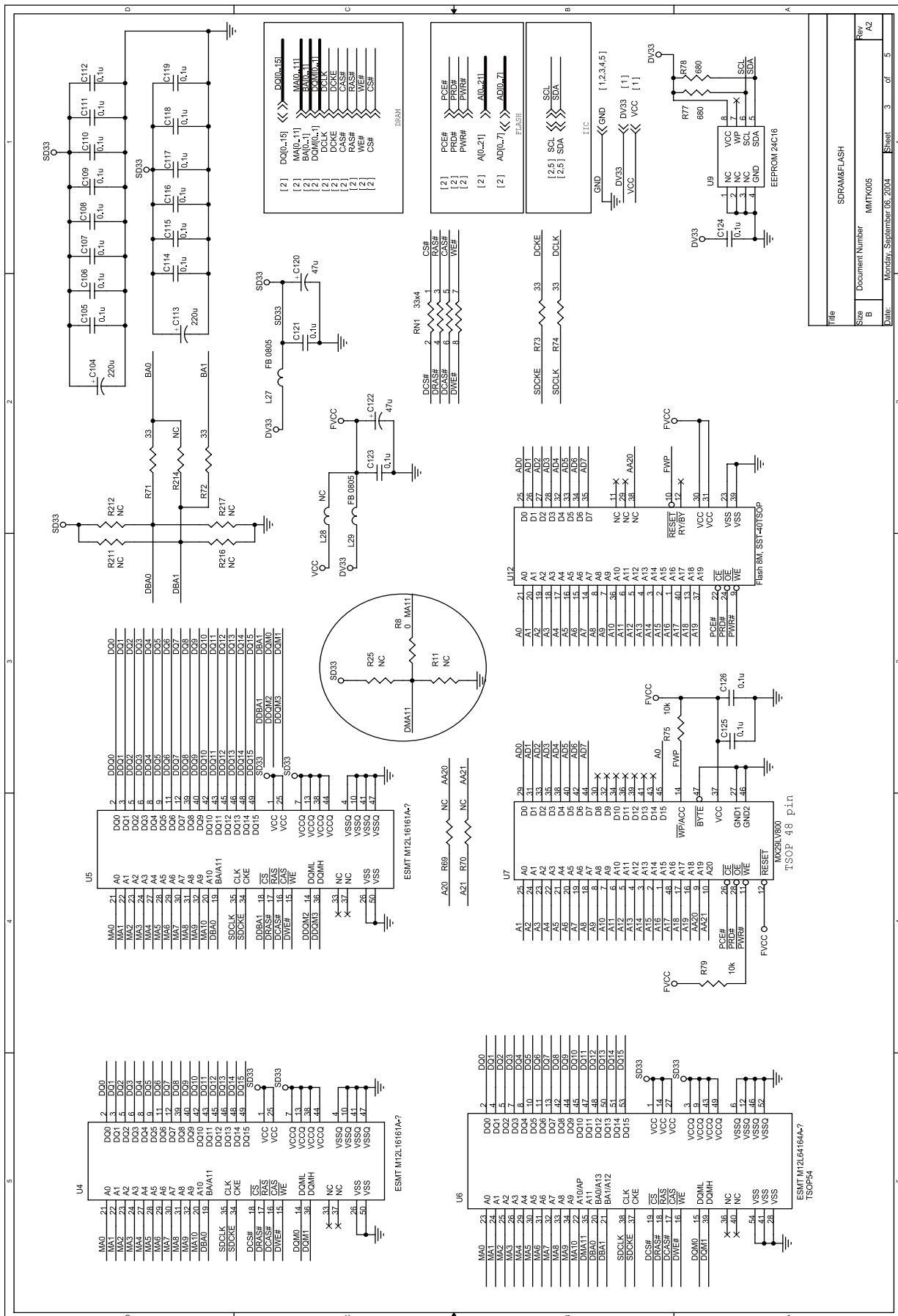

CIRCUIT DIAGRAM

4) VIDEO OUTPUT PORT SCHEMATIC DIAGRAM

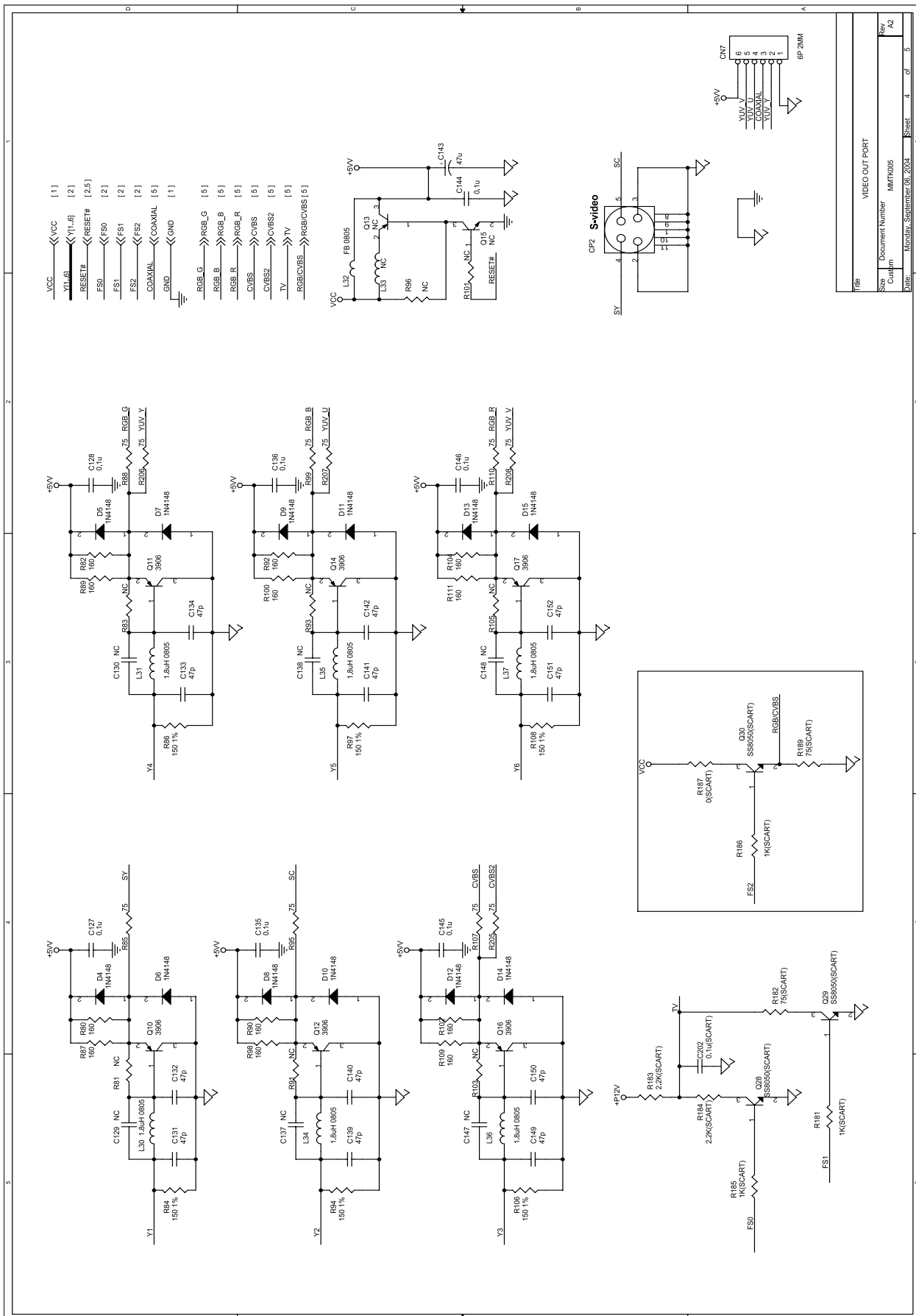

CONTROL BOARD SCHEMATIC DIAGRAM (DG-K513S)

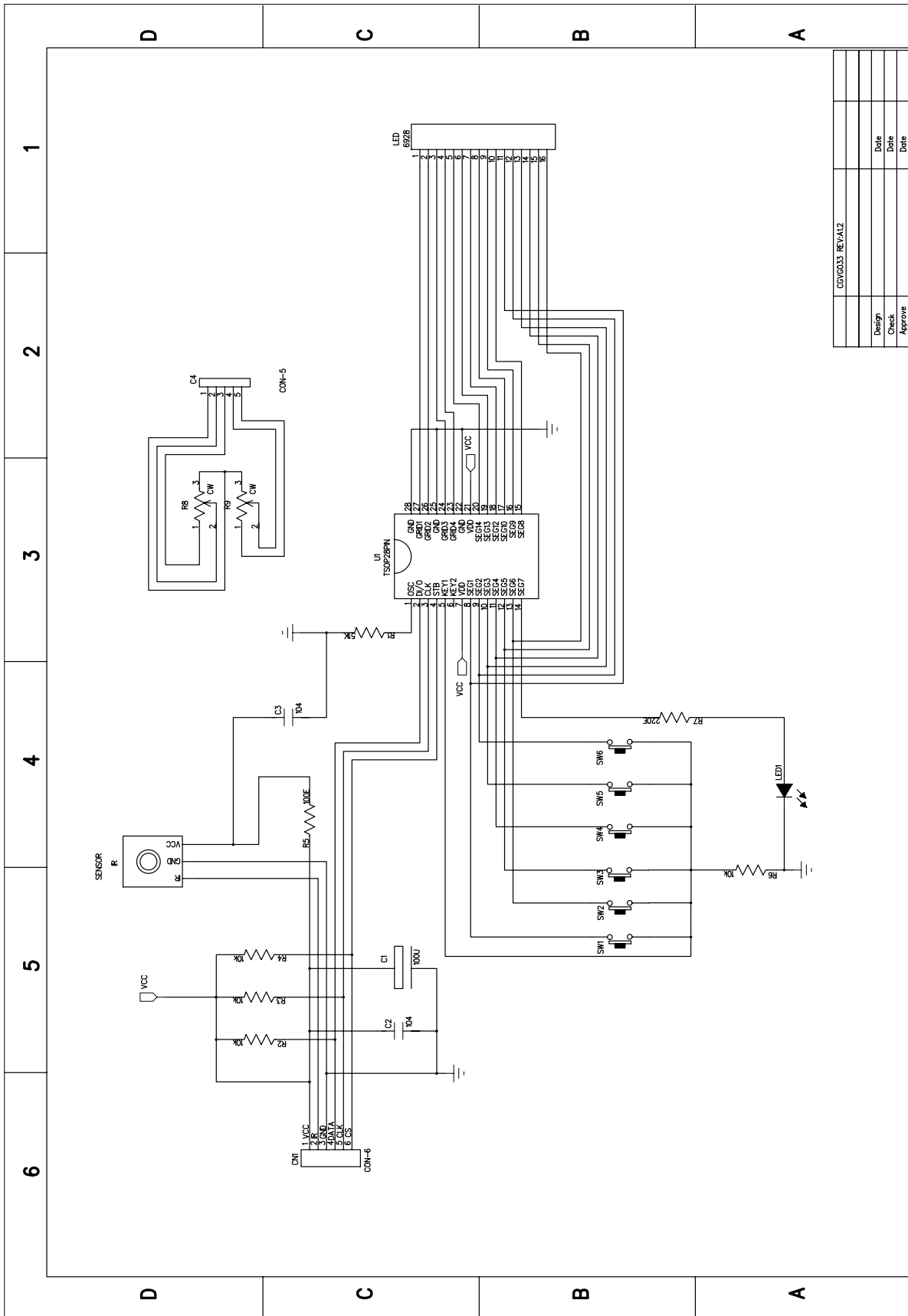

4. MICROPHONE BOARD SCHEMATIC DIAGRAM (DG-K511S/DG-K516S)

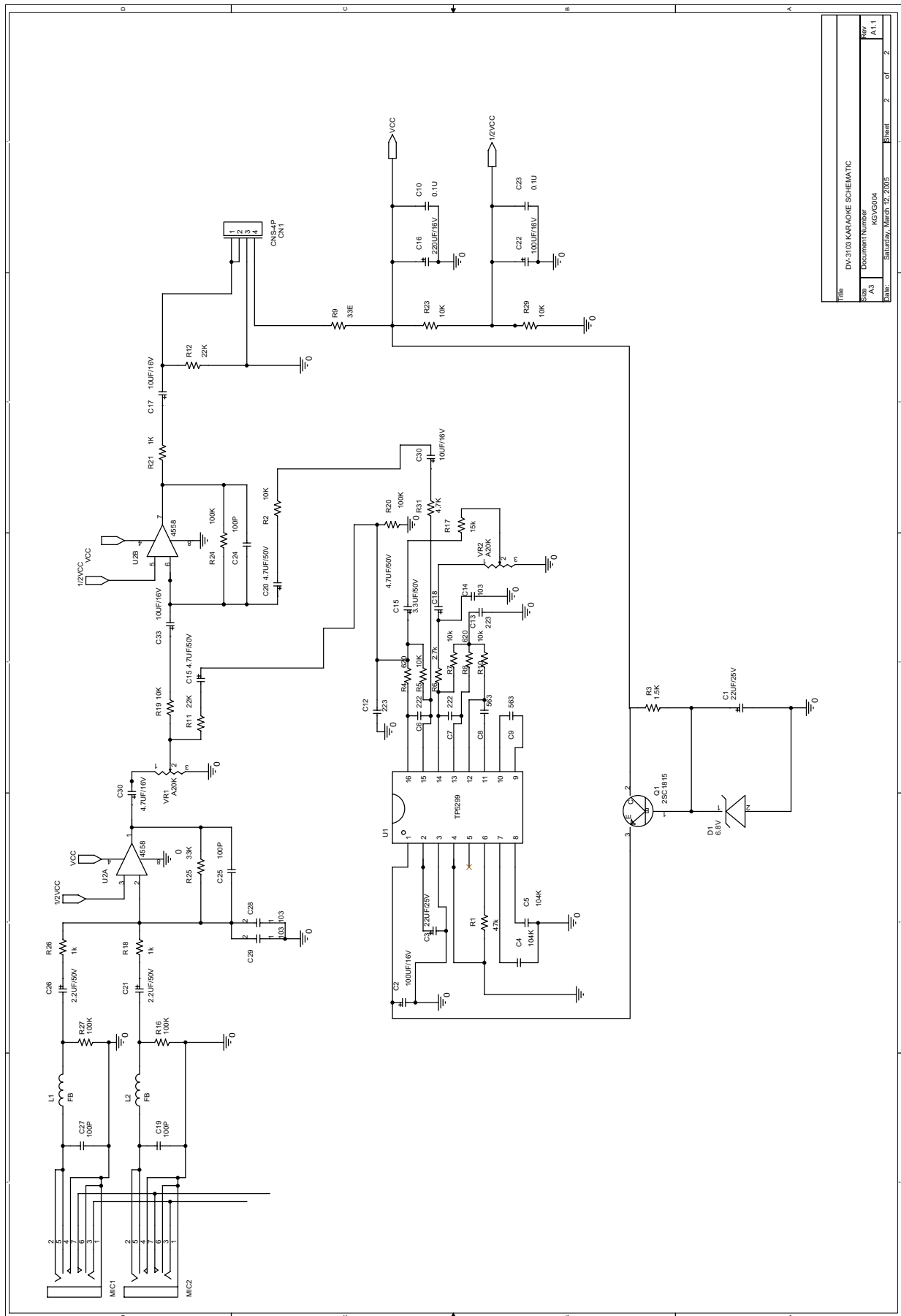

CIRCUIT DIAGRAM

MICROPHONE BOARD SCHEMATIC DIAGRAM (DG-K513S)

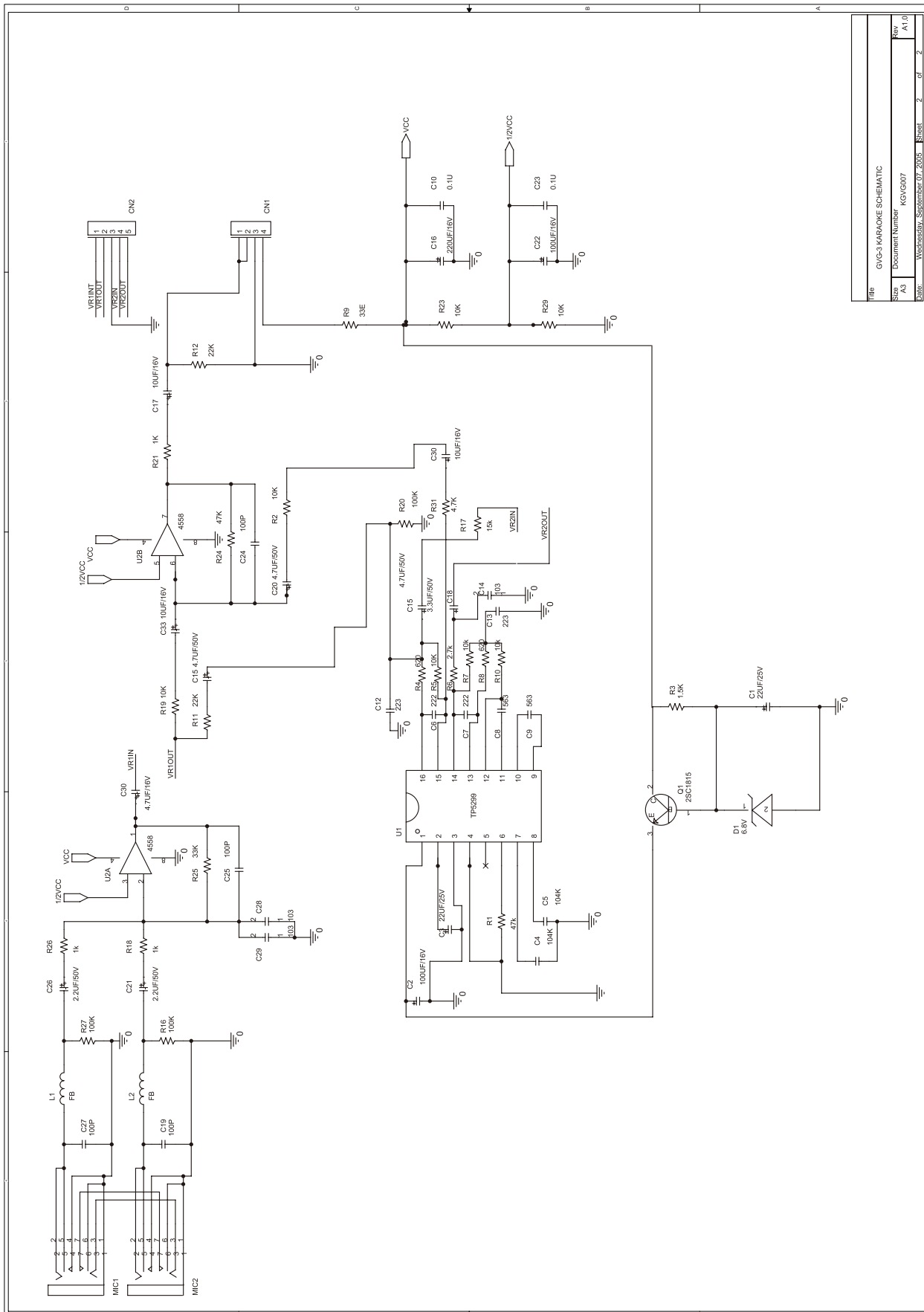

File	GVC-3 KARAOKE SCHEMATIC
Size	Document Number
A3	KGV/G07
Rev	A1.0
Drawn	Wednesday, September 07, 2005
Sheet	2 of 2

5. YUV BOARD SCHEMATIC DIAGRAM

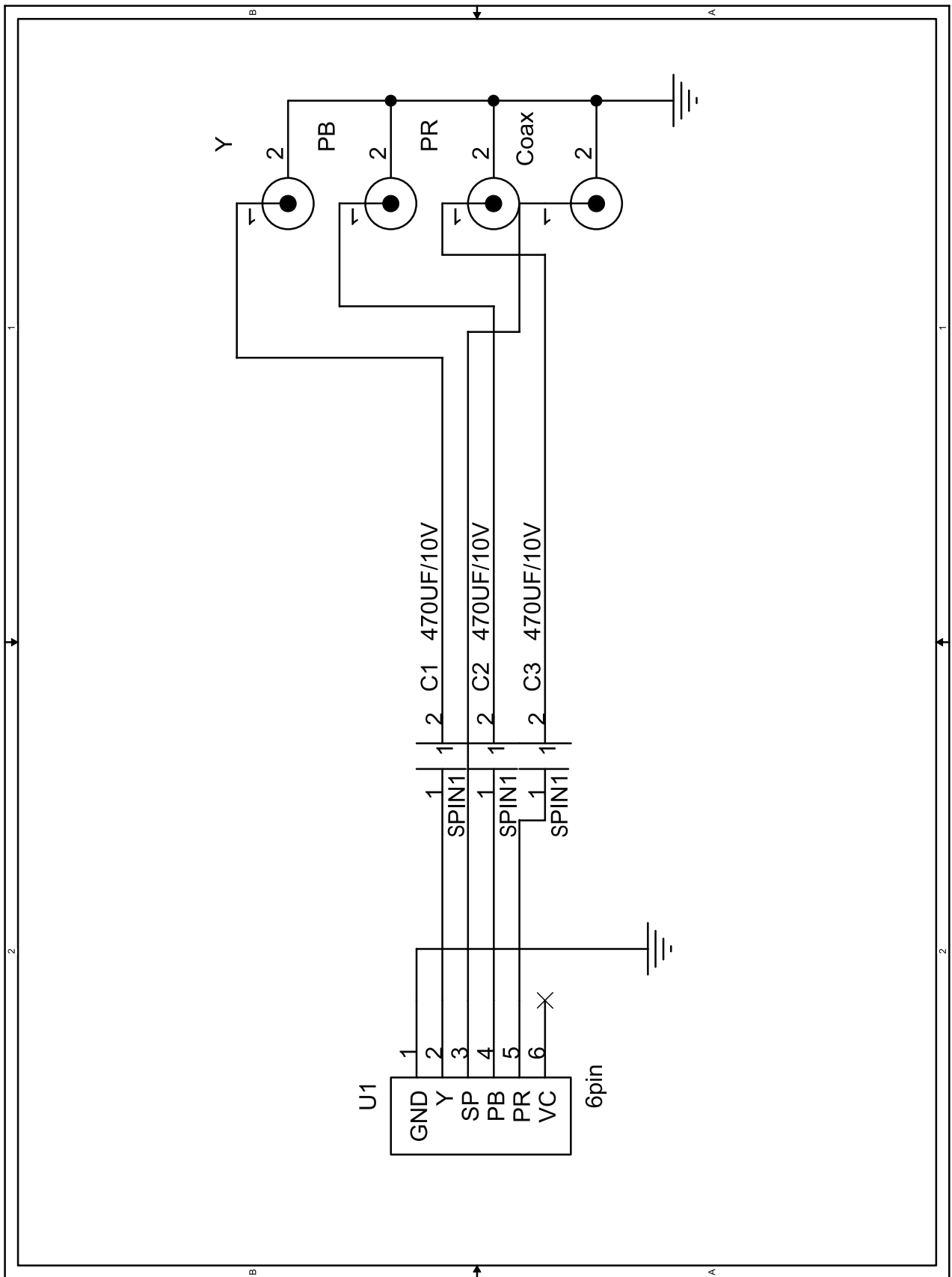

PCB CIRCUIT BOARD

1. POWER SUPPLY BOARD

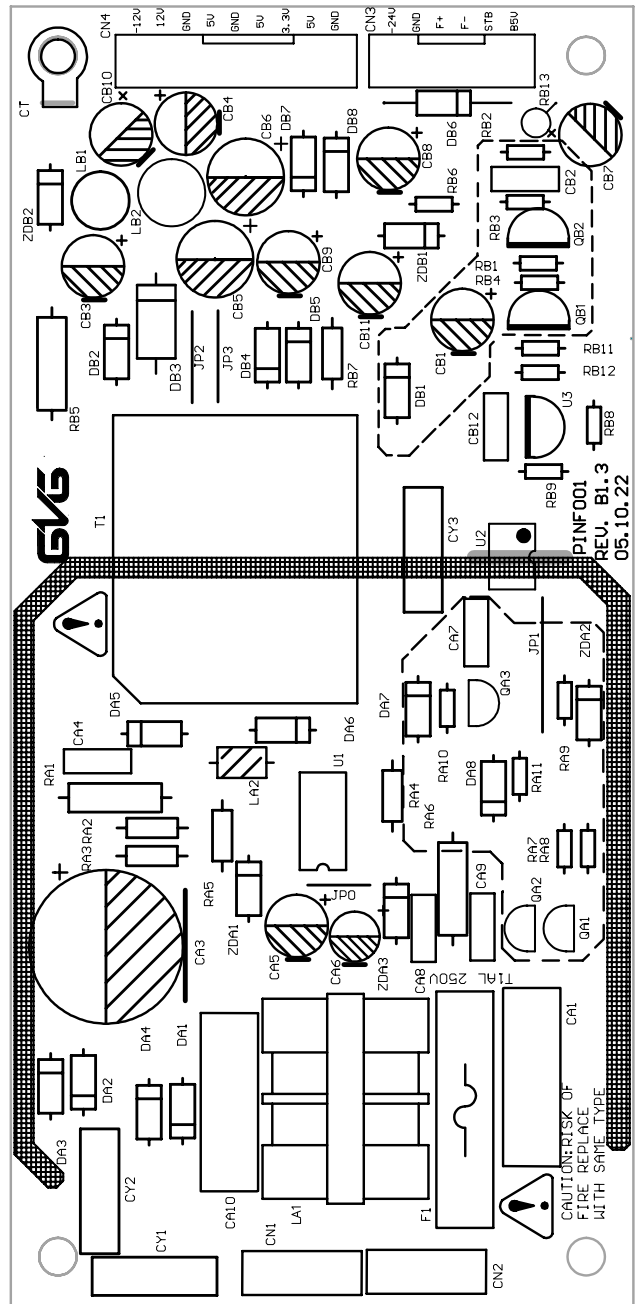
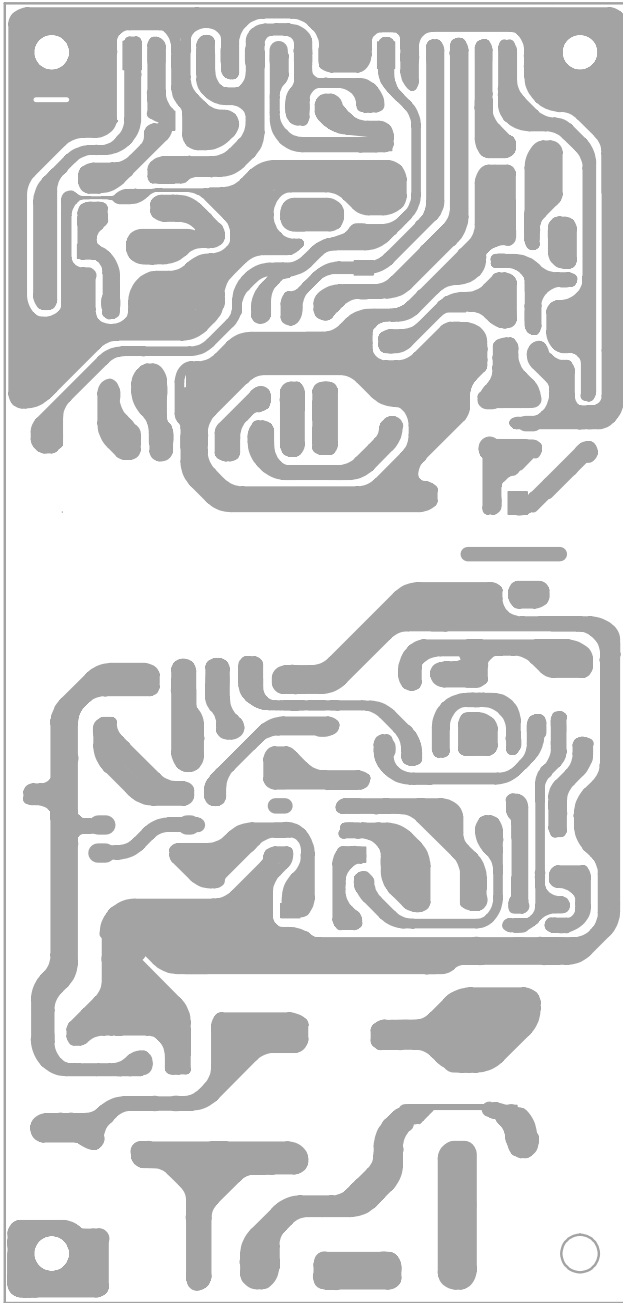

2. DECODE BOARD

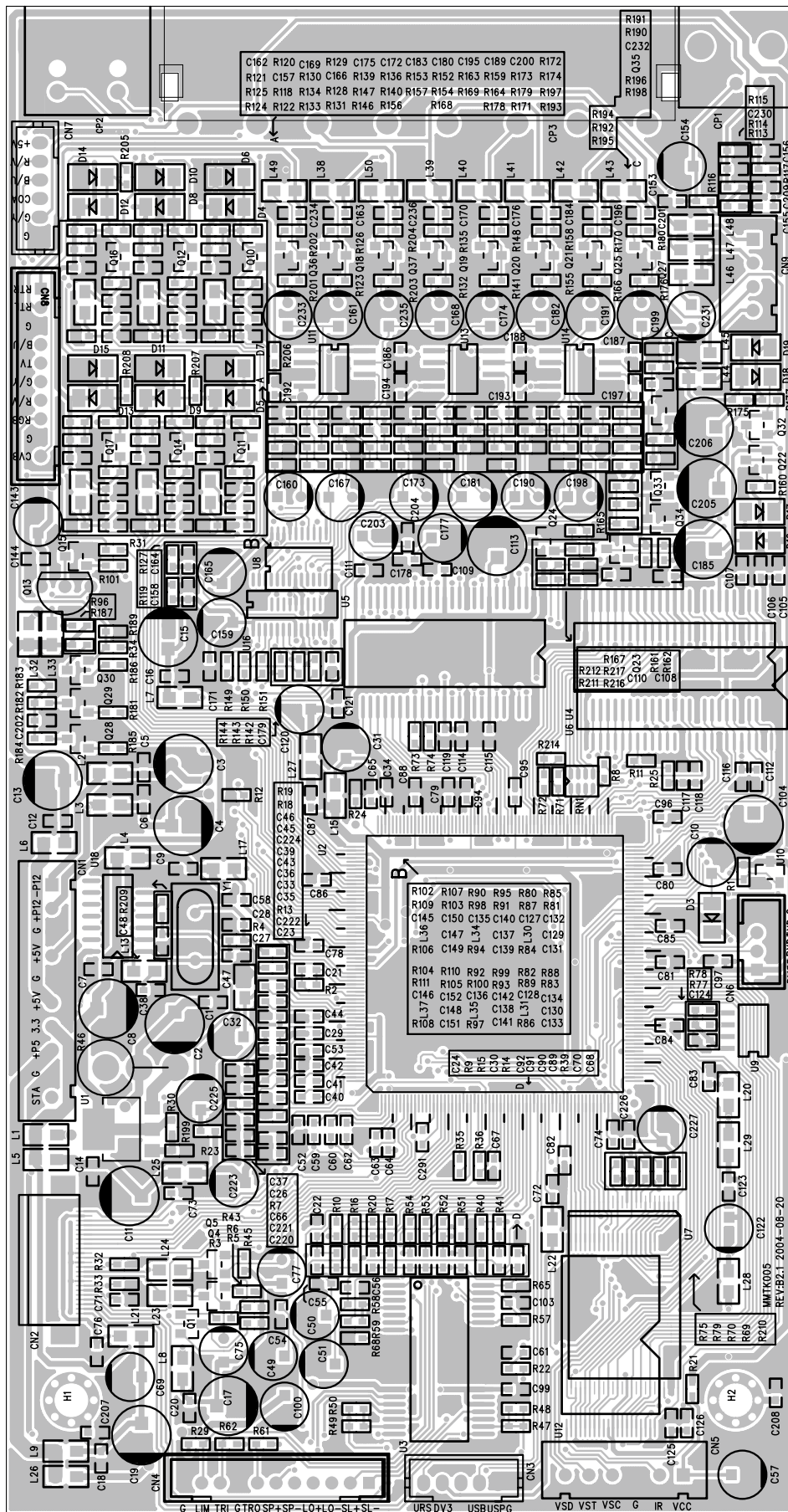



PCB CIRCUIT BOARD

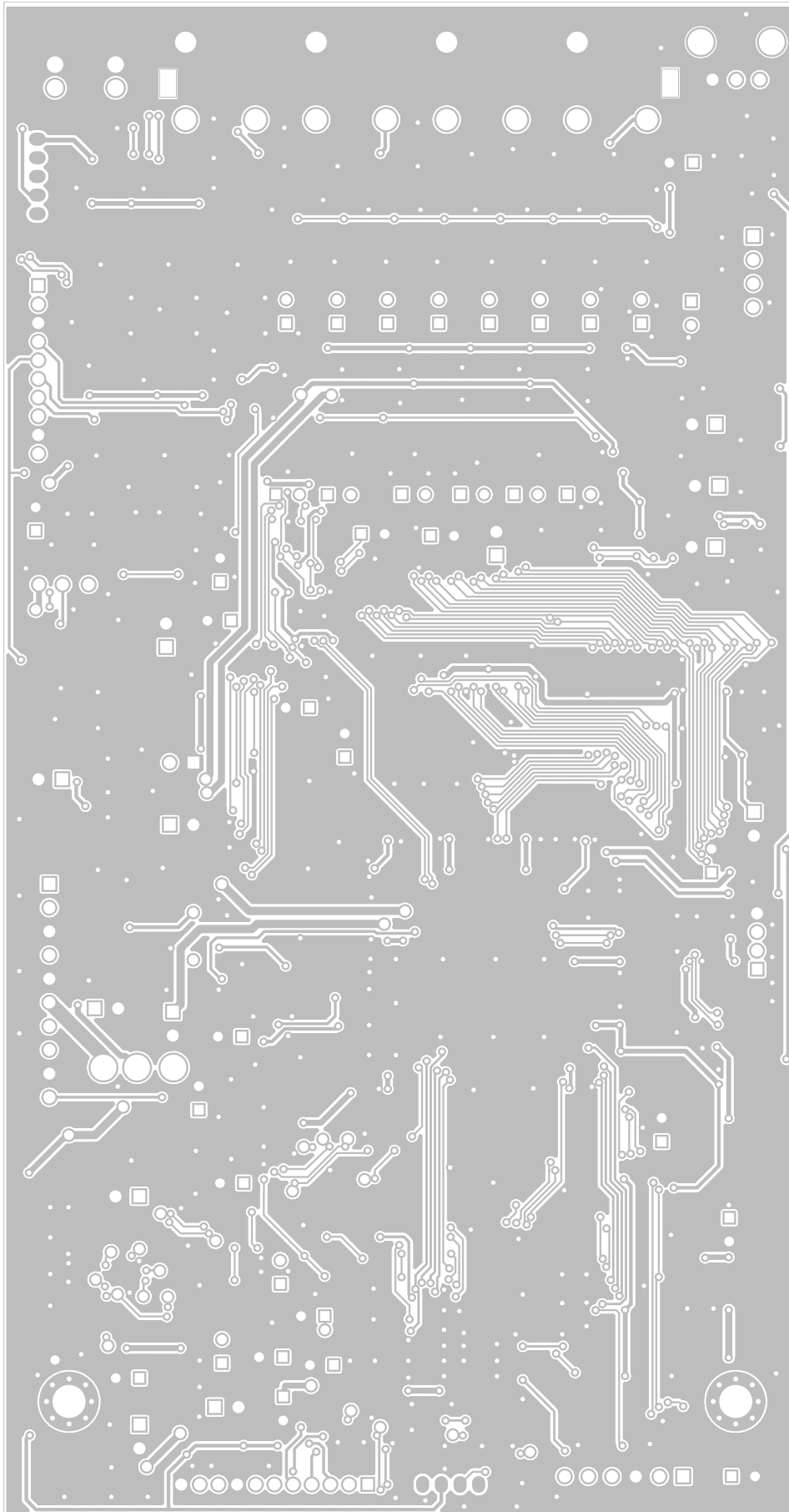



PCB CIRCUIT BOARD

3. CONTROL BOARD (DG-K511S)

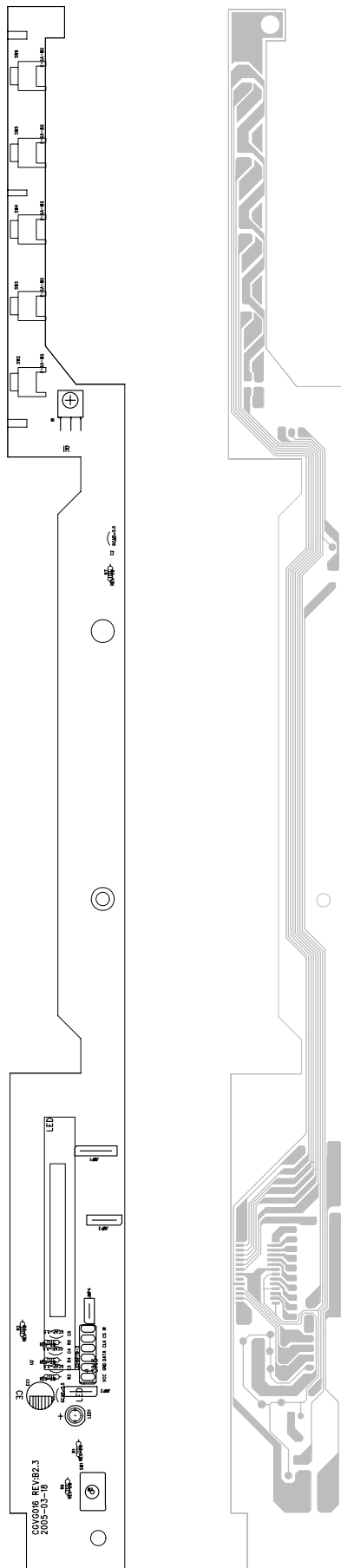



PCB CIRCUIT BOARD

CONTROL BOARD (DG-K513S)

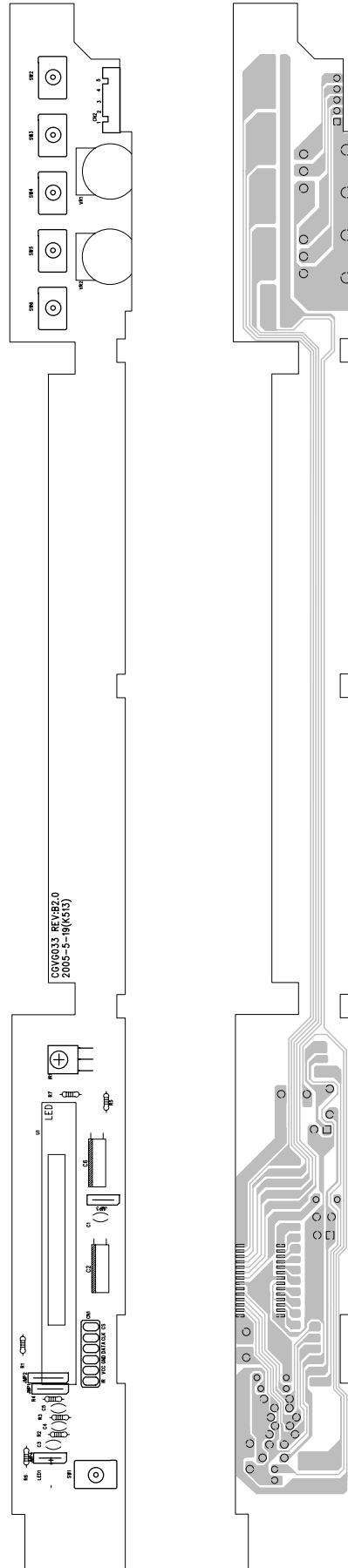



PCB CIRCUIT BOARD

CONTROL BOARD (DG-K516S)

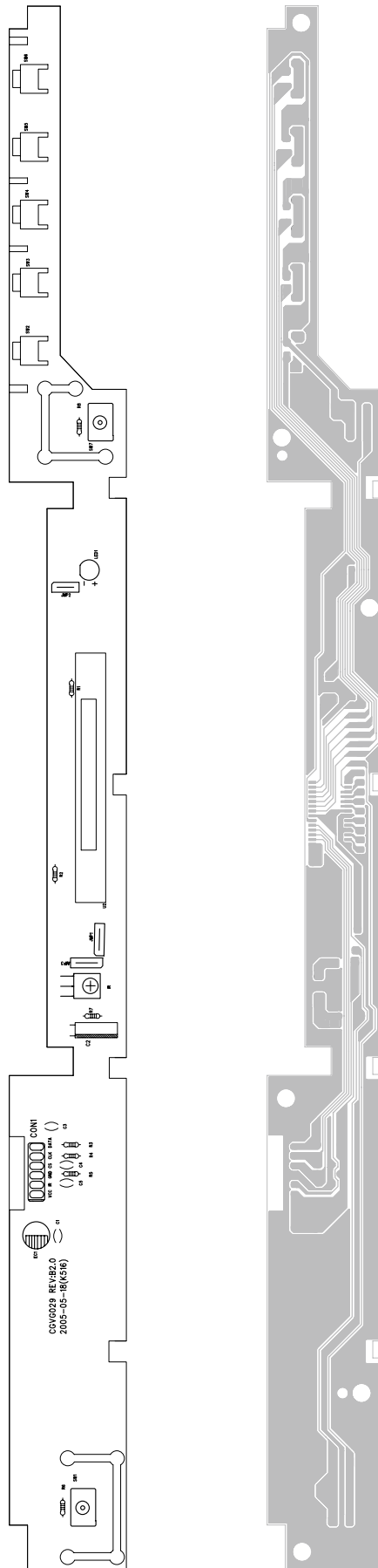

PCB CIRCUIT BOARD

4. MICROPHONE BOARD (DG-K511S)

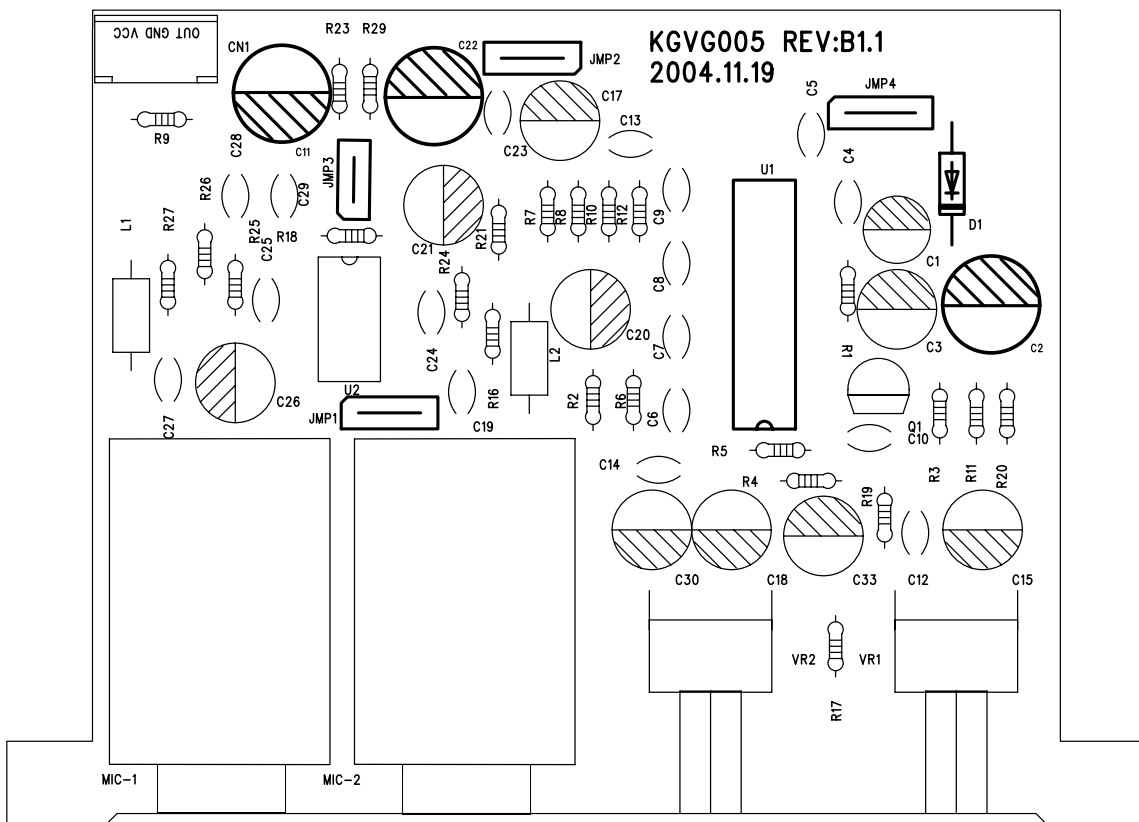
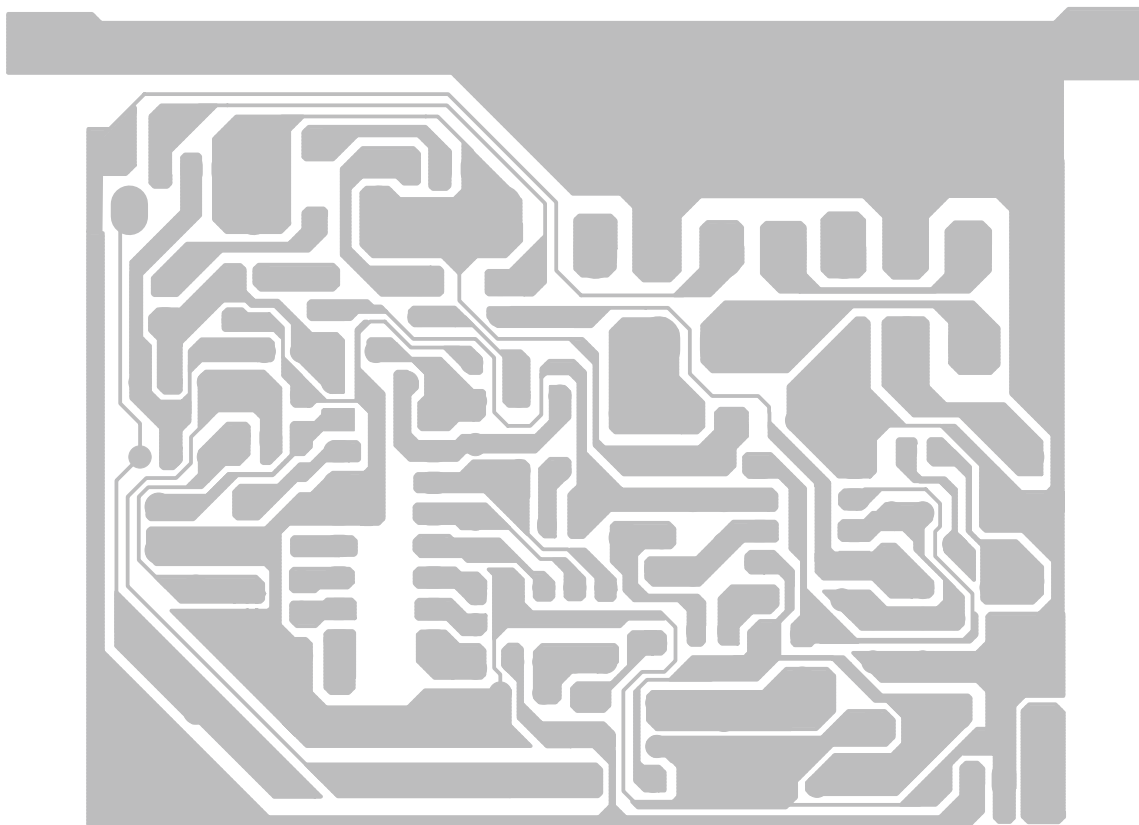

MICROPHONE BOARD (DG-K513S)

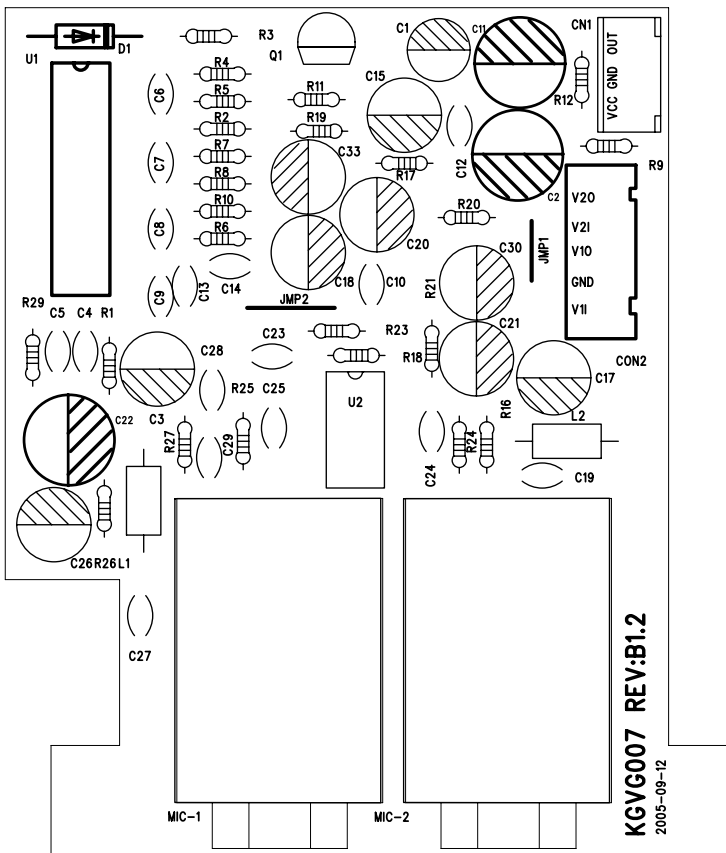
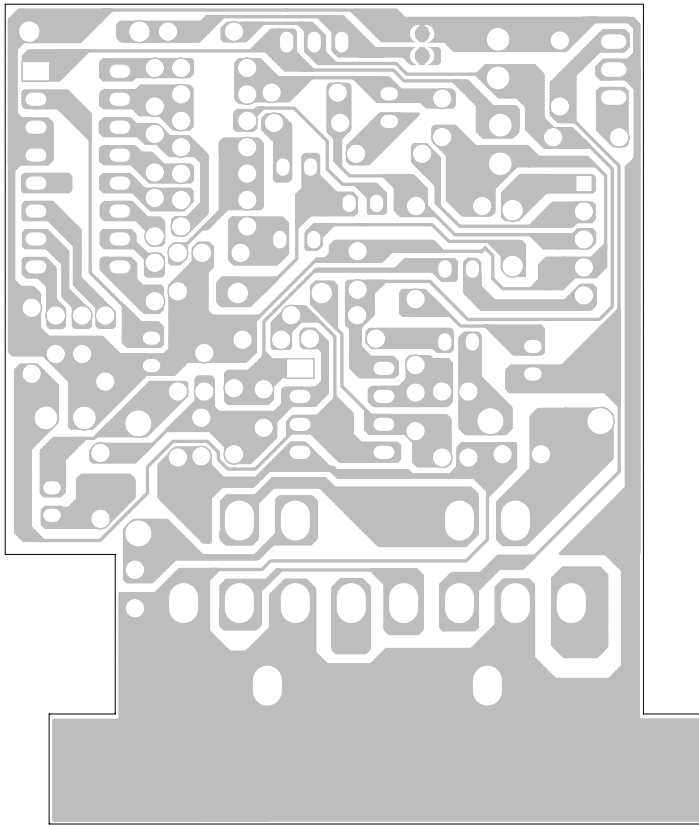

PCB CIRCUIT BOARD

MICROPHONE BOARD (DG-K516S)

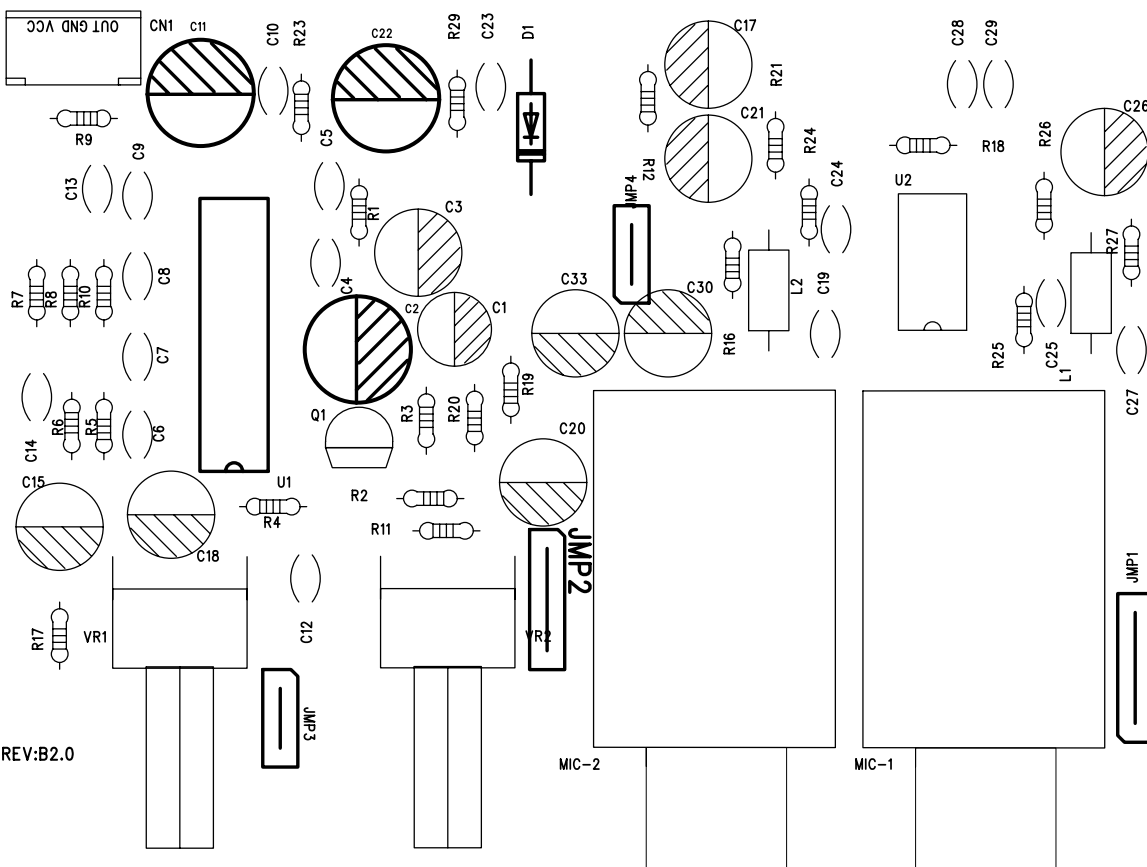
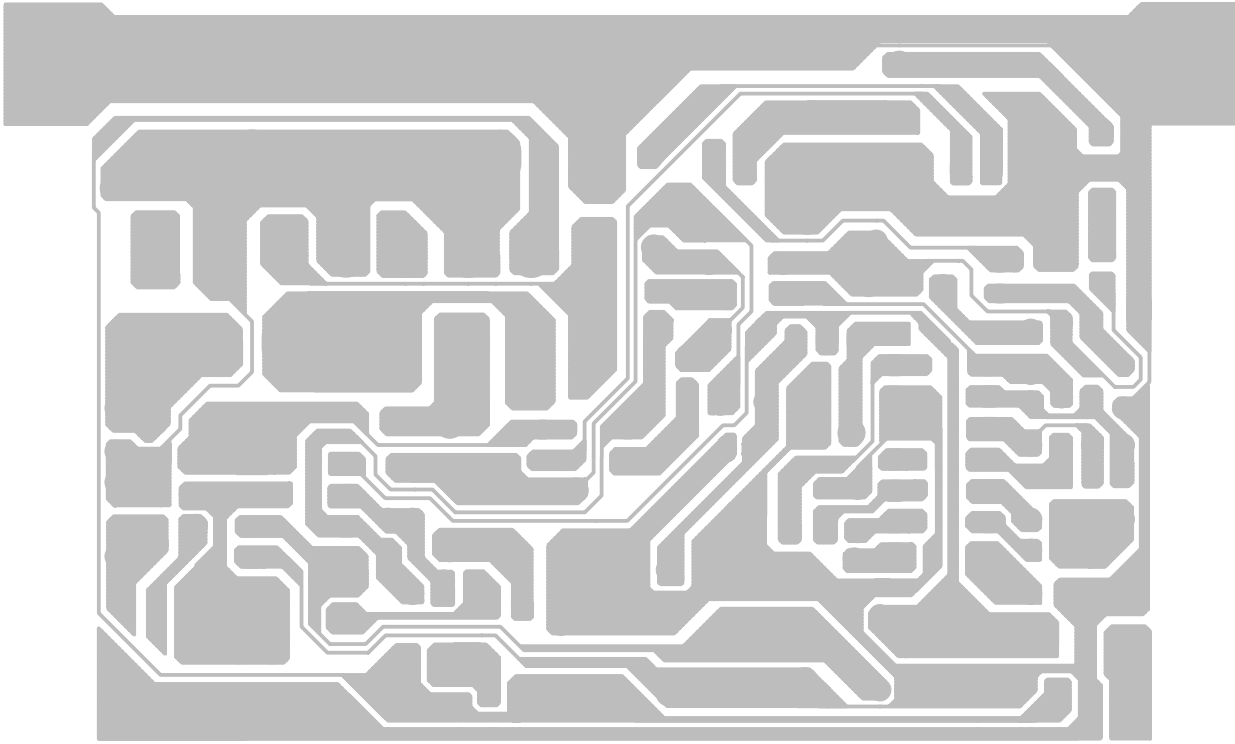

KGVG004 REV:B2.0
2004.11.16



PCB CIRCUIT BOARD

5. YUV OUTPUT BOARD

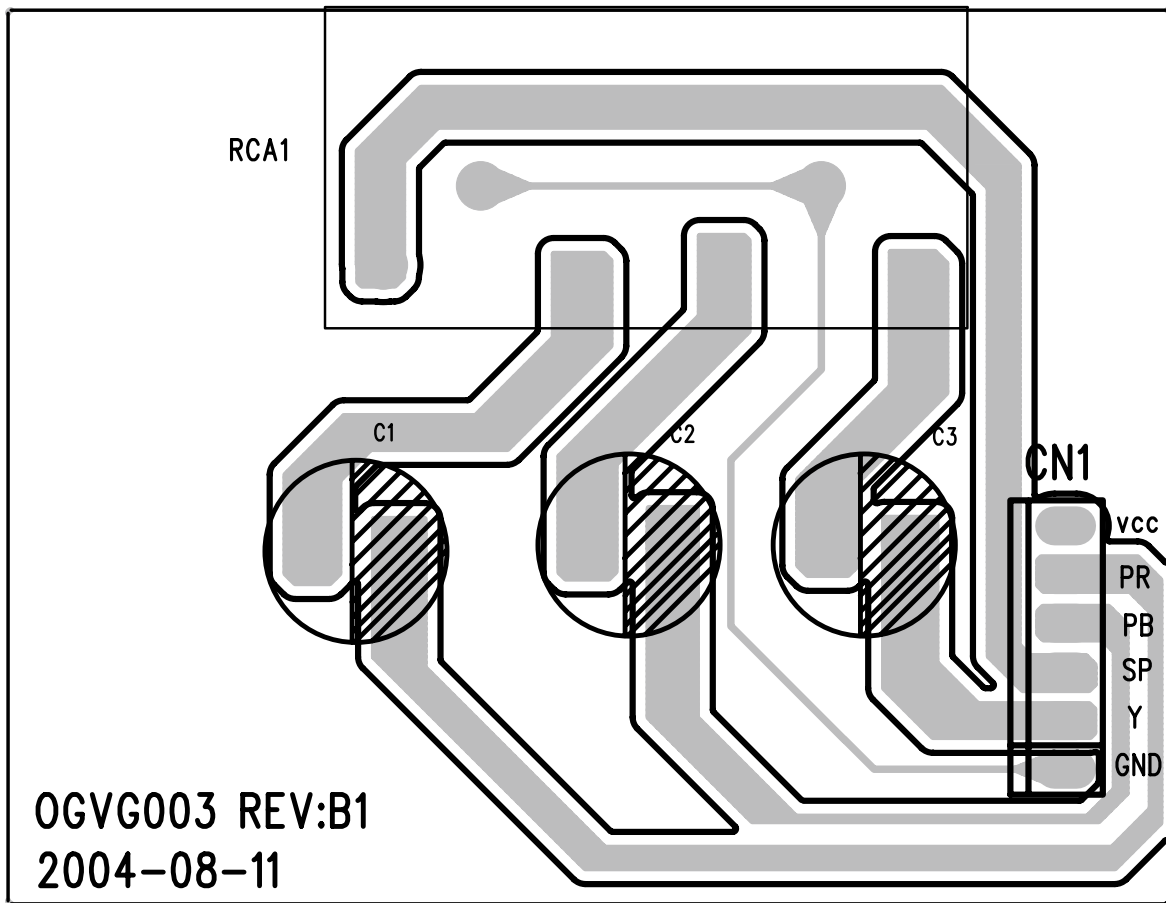

WAVEFORMS

1. VIDEO

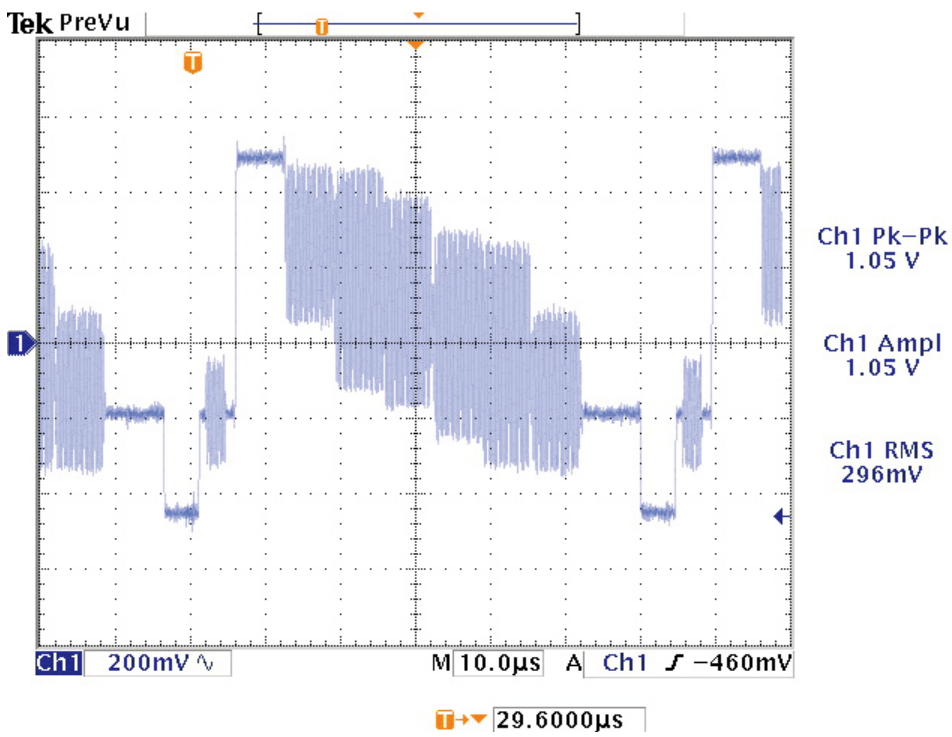

CP3 Pin5 (COLOR BAR_VIDEO OUT) CVBS

2. AUDIO

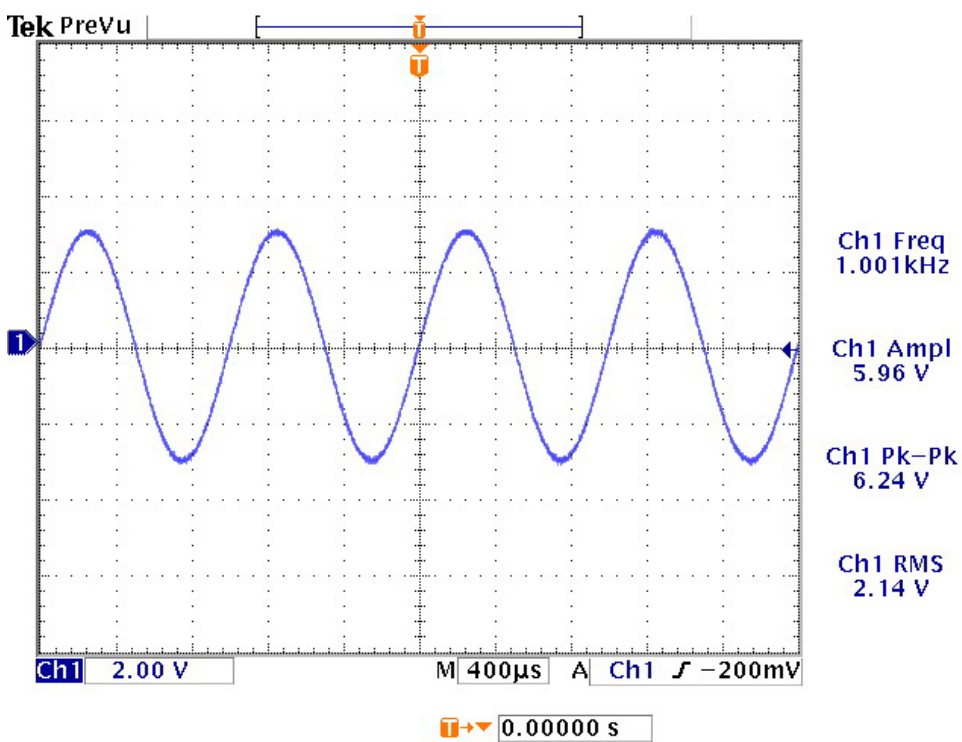

CP3 Pin 7&8(1KHz_AUDIO OUT)

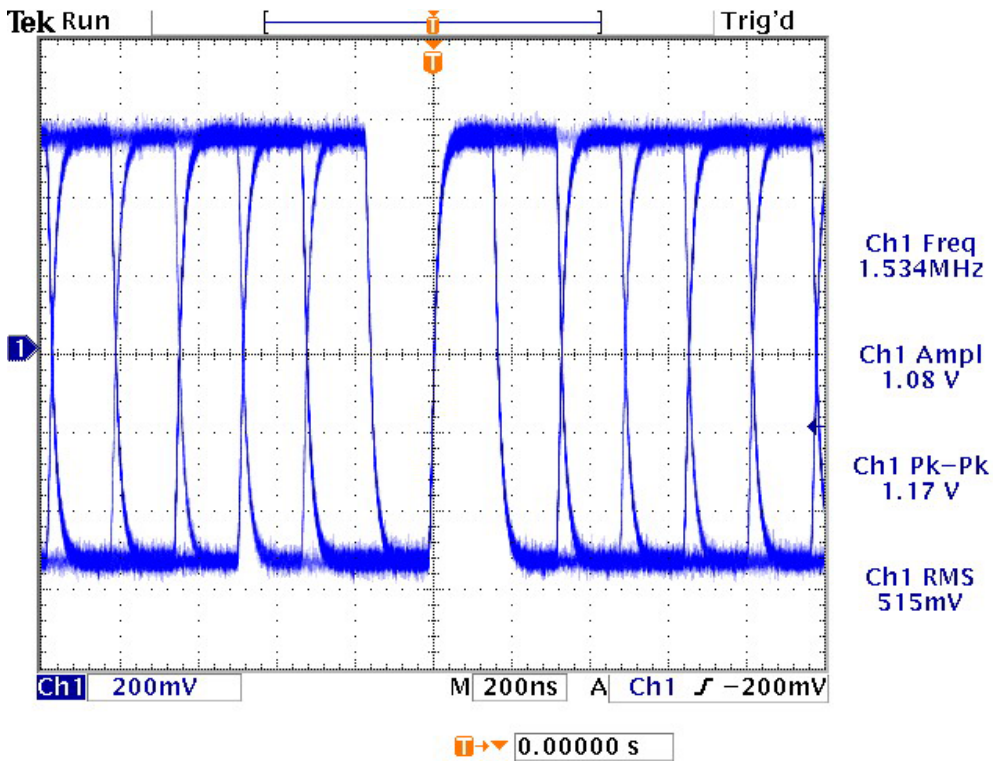

CP3 Pin6 (COAXIAL OUT)

3. SYSTEM WAVEFORMS

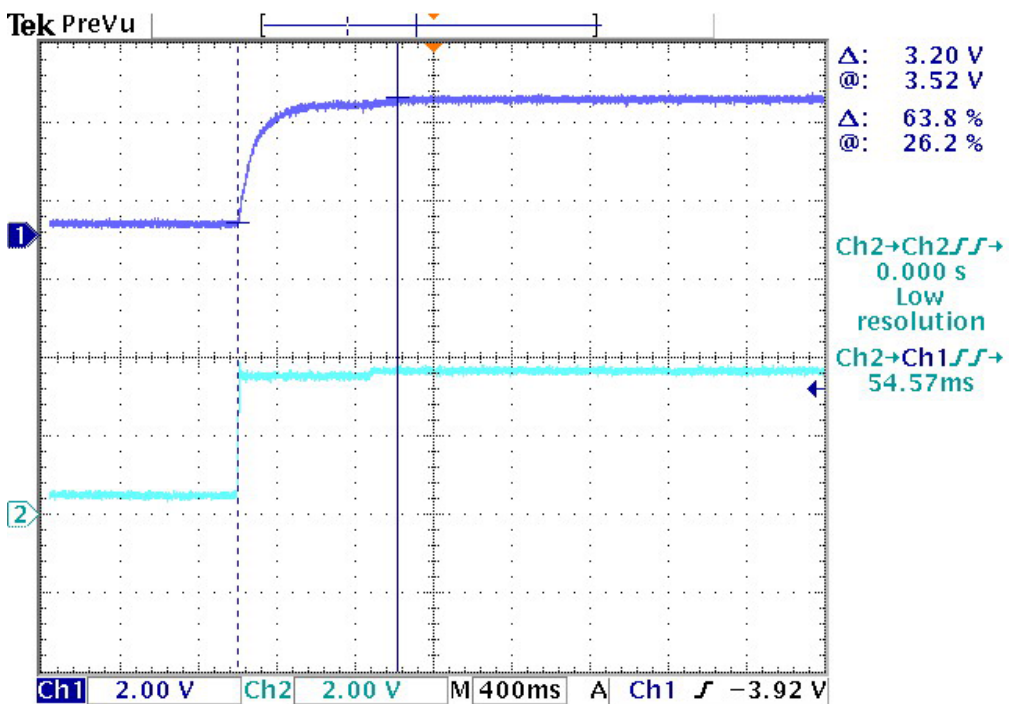

D3 Pin2 RESET & +3.3V ON/OFF

WAVEFORMS

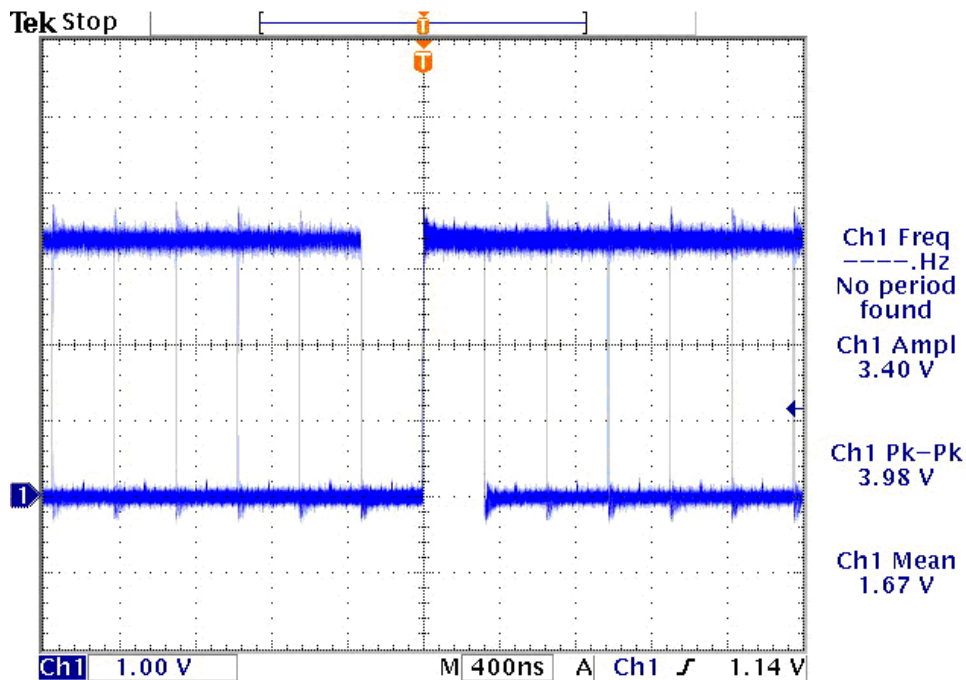

0.00000 s

(AUDIO SDAT0) U16:CS4360 Pin2

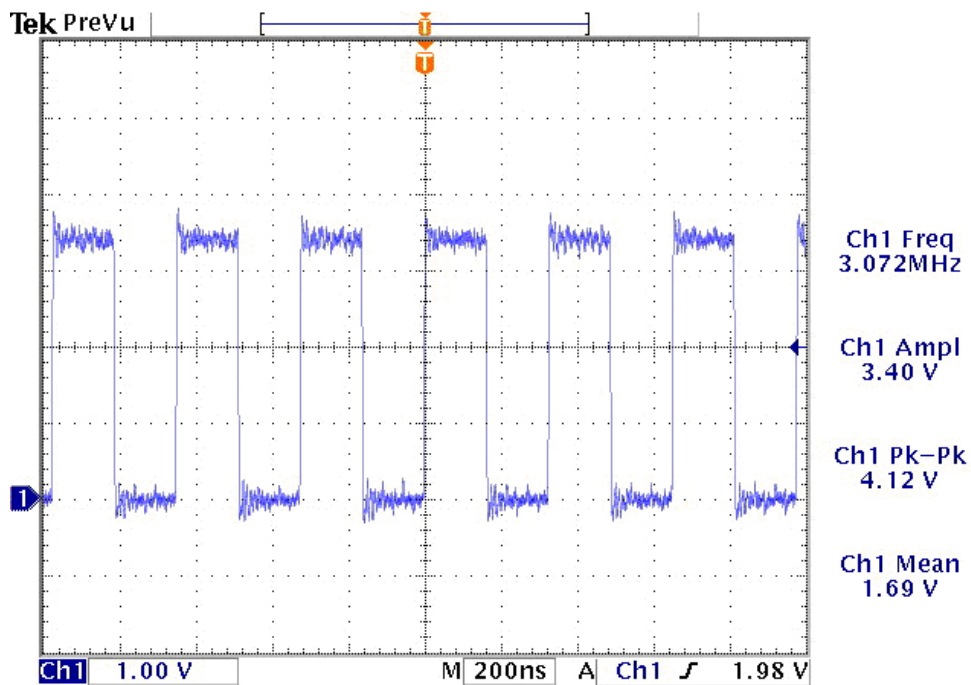

0.00000 s

(AUDIO SBCLK) U16:CS4360 Pin5

WAVEFORMS

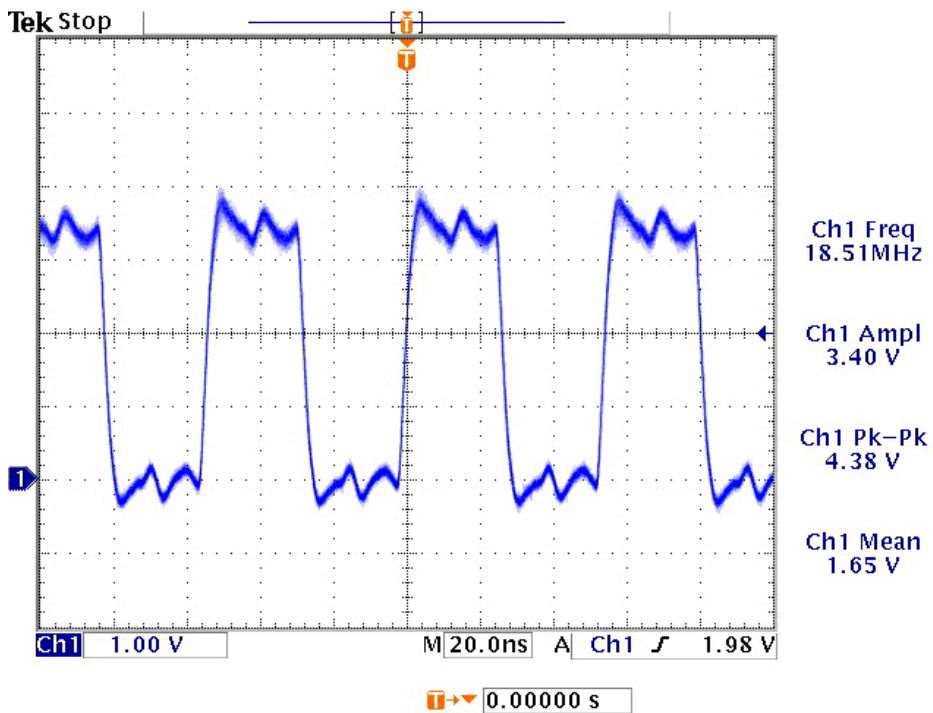

(AUDIO SACLK) U16:CS4360 Pin7

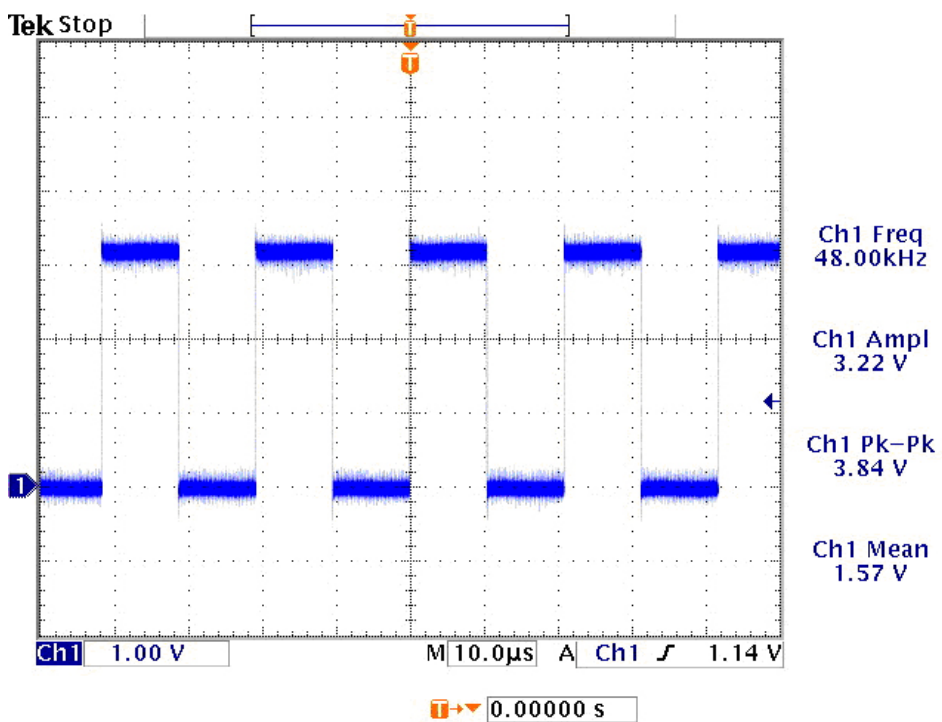

(AUDIO SLRCK) U16:CS4360 Pin6

WAVEFORMS

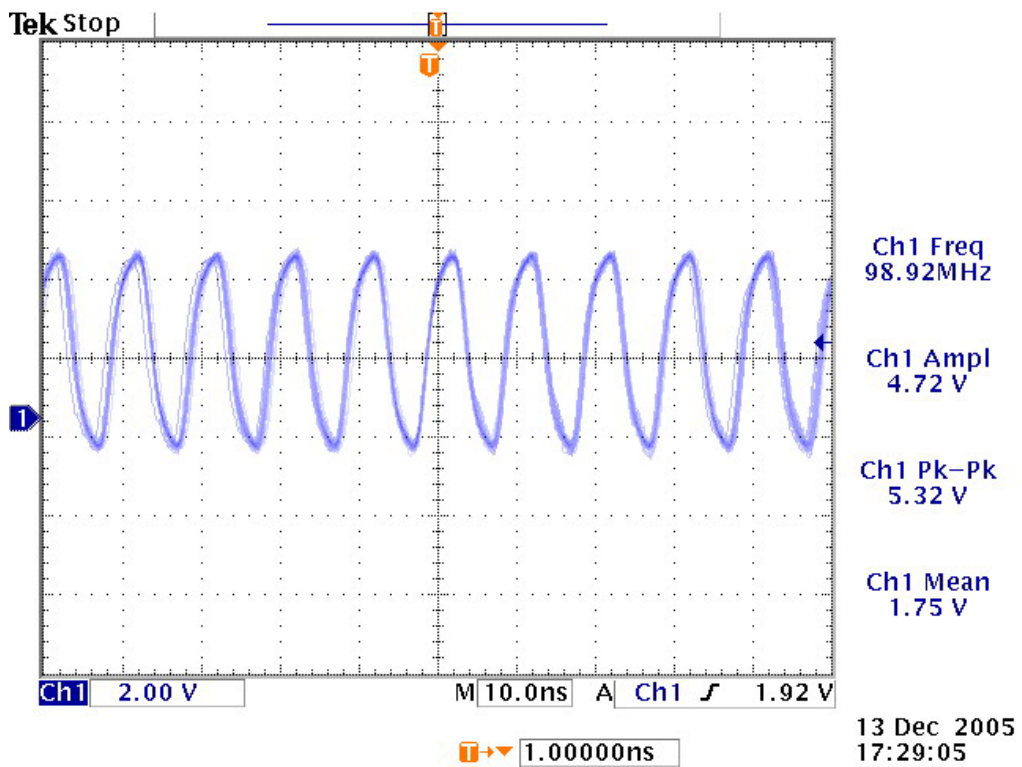

(SDRAM CLOCK) U6 Pin38

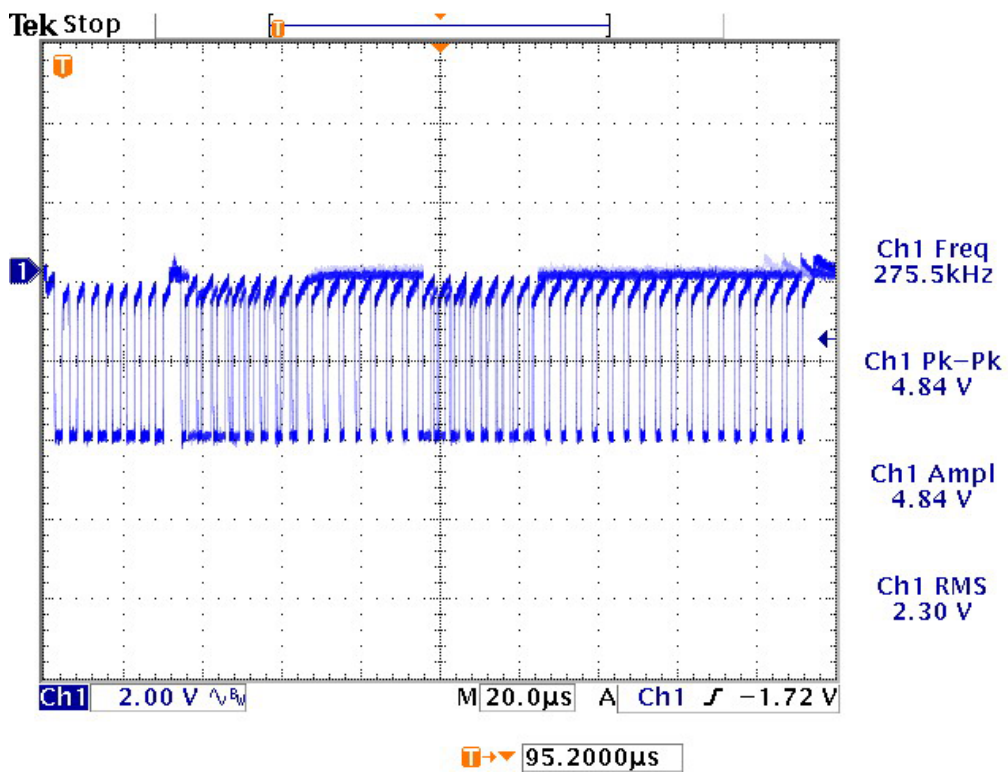

CN4 Pin4(VSC) S-CLK

WAVEFORMS

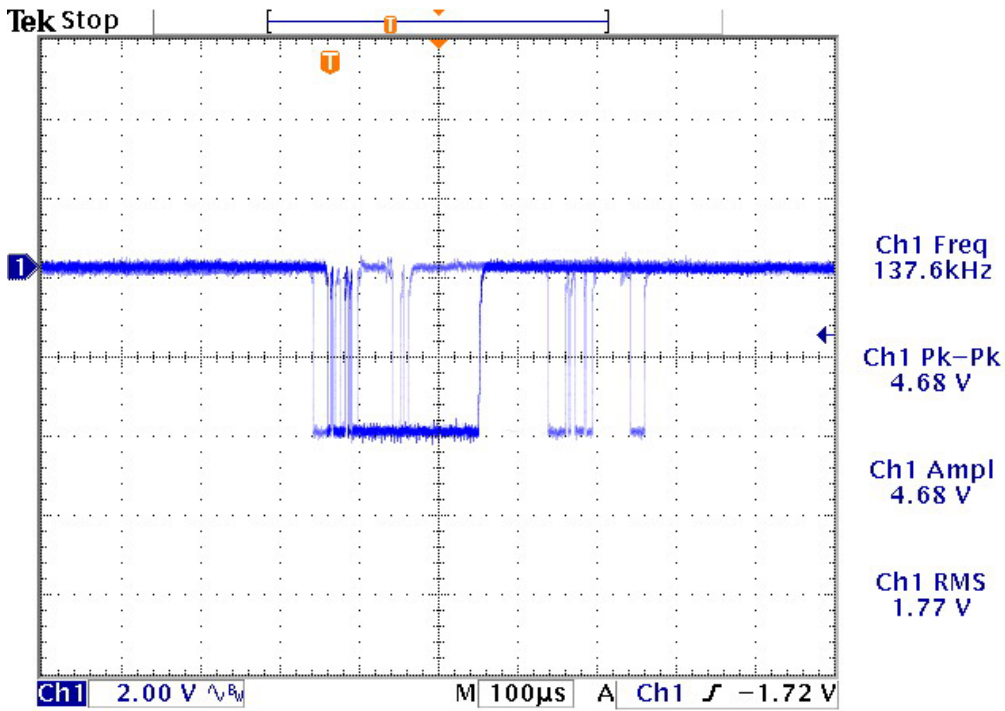

135.600μs

CN4 Pin6 (VSD) SDATA-IN

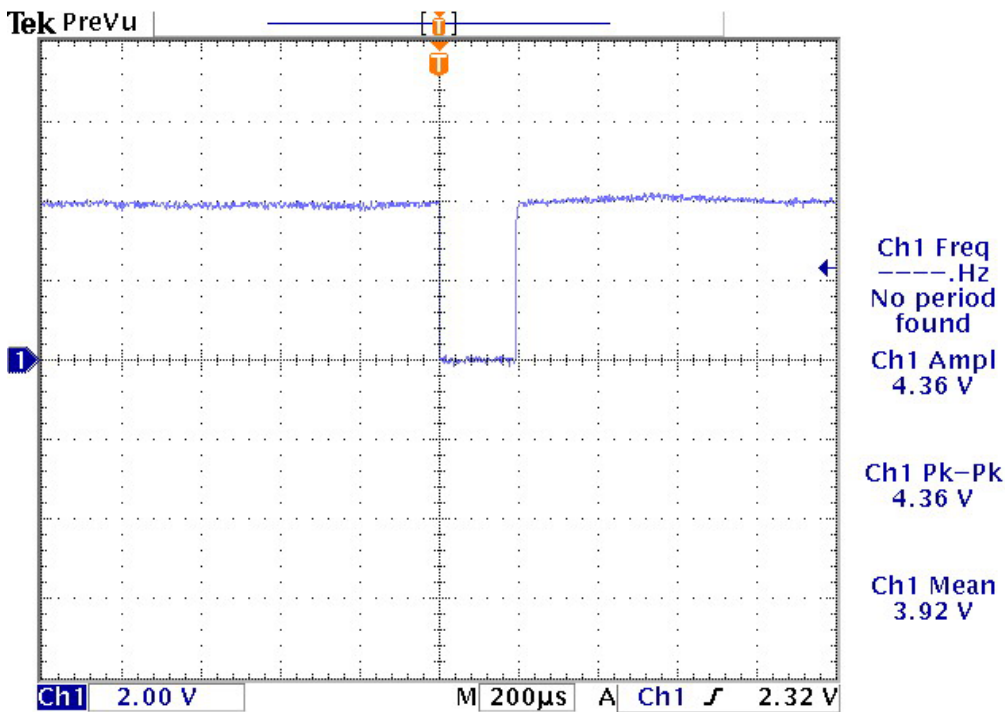

0.00000 s

13 Dec 2005
18:03:55

CN4 Pin5 (VST) S-CS

WAVEFORMS

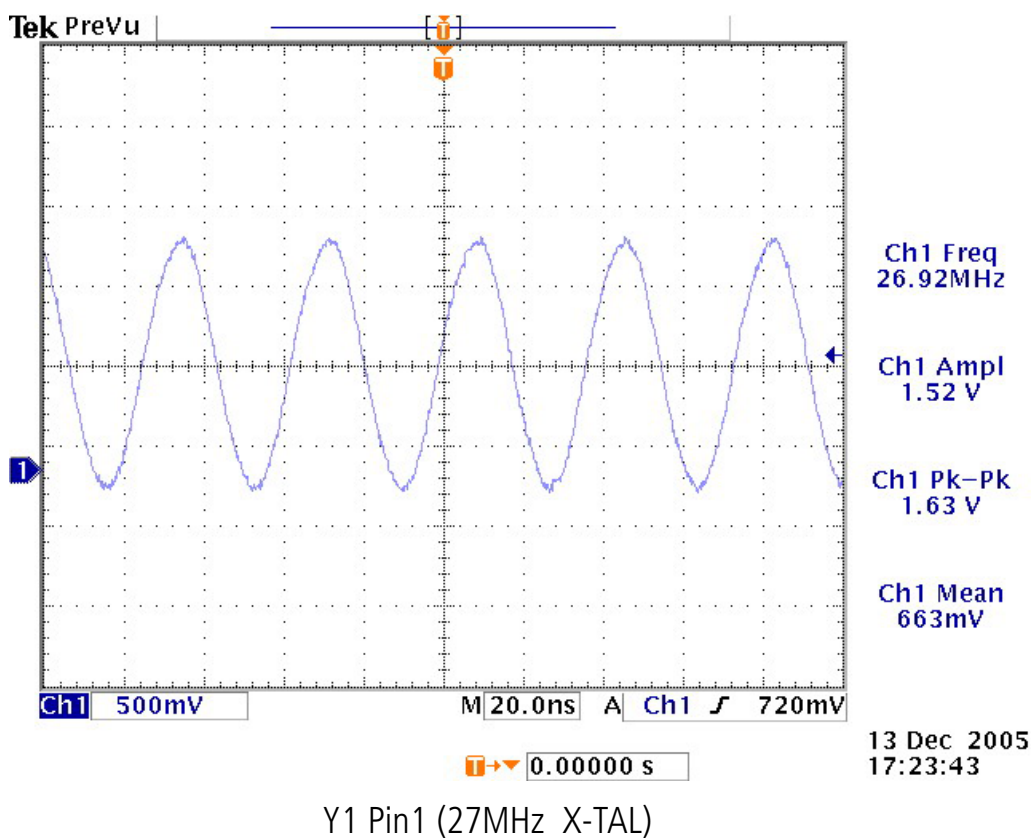
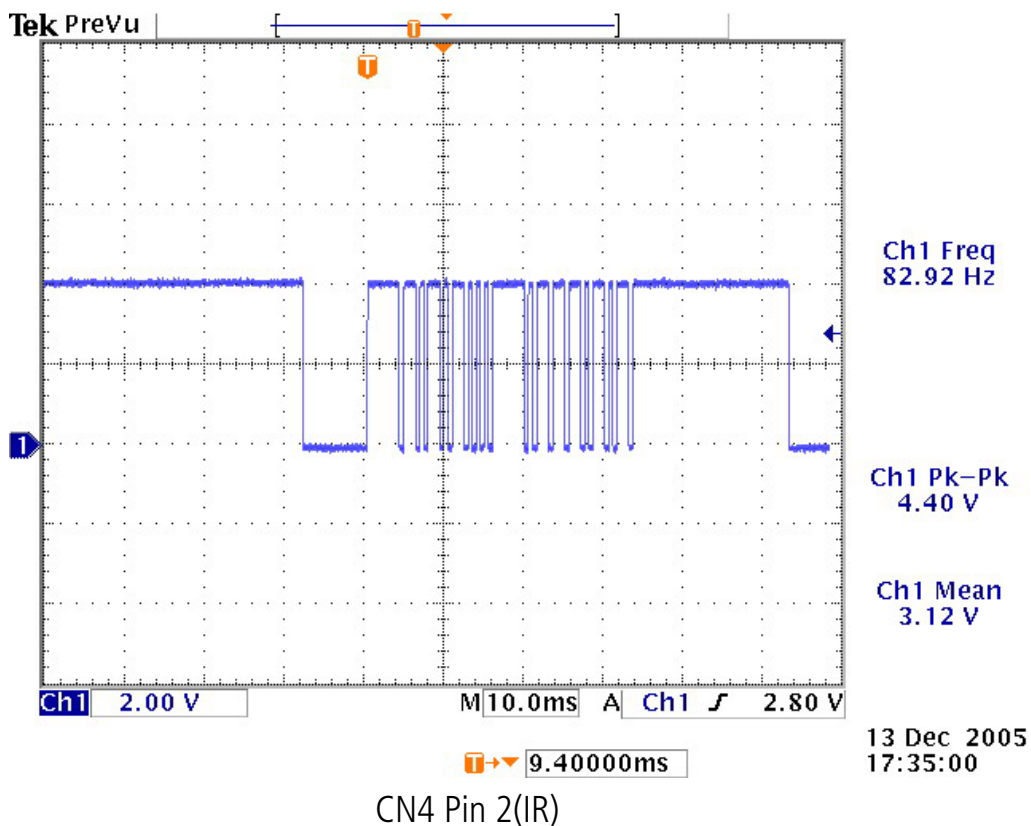

TROUBLE SHOOTING

1. POWER CIRCUIT

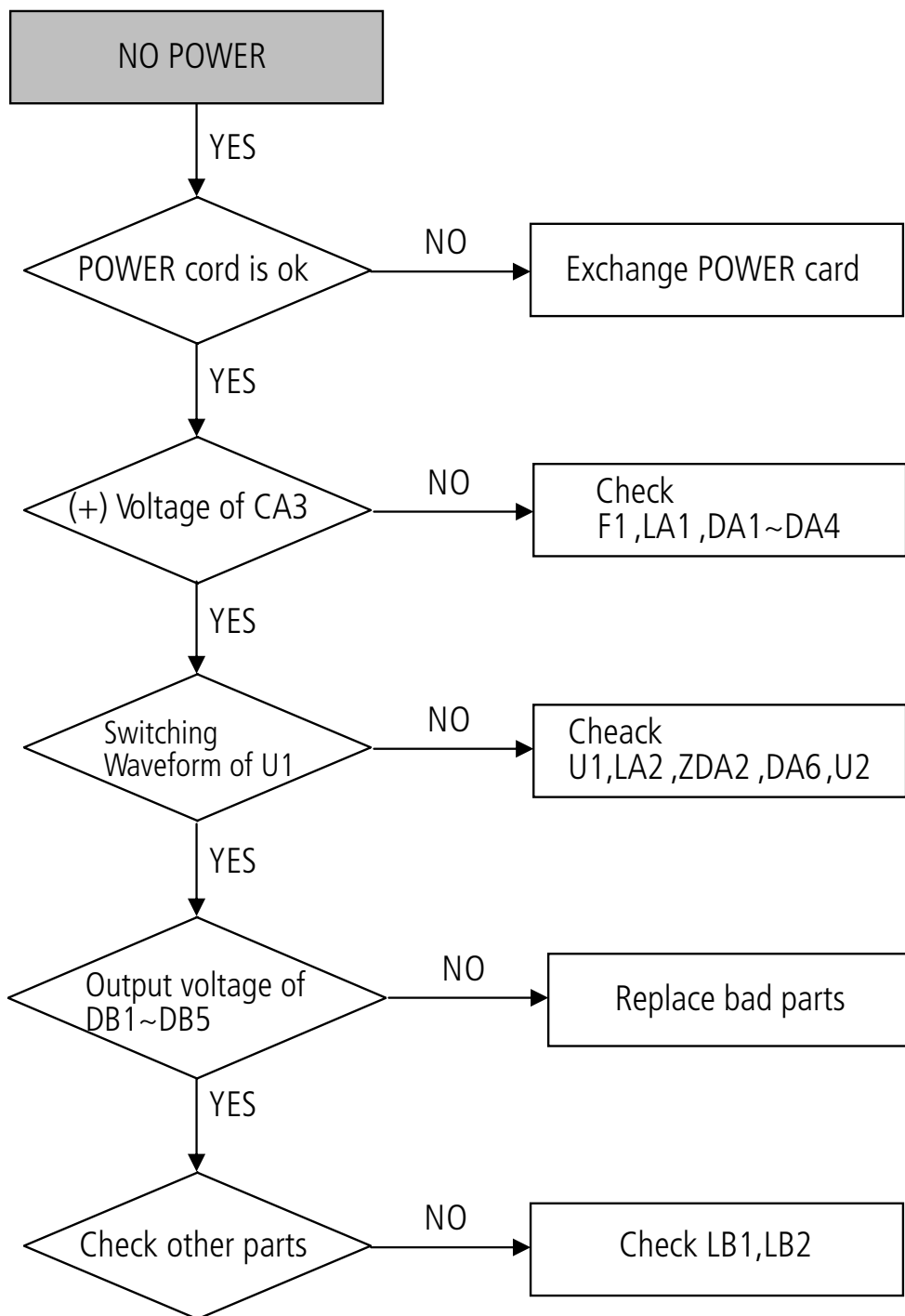

TROUBLE SHOOTING

2. CONTROL BOARD CIRCUIT

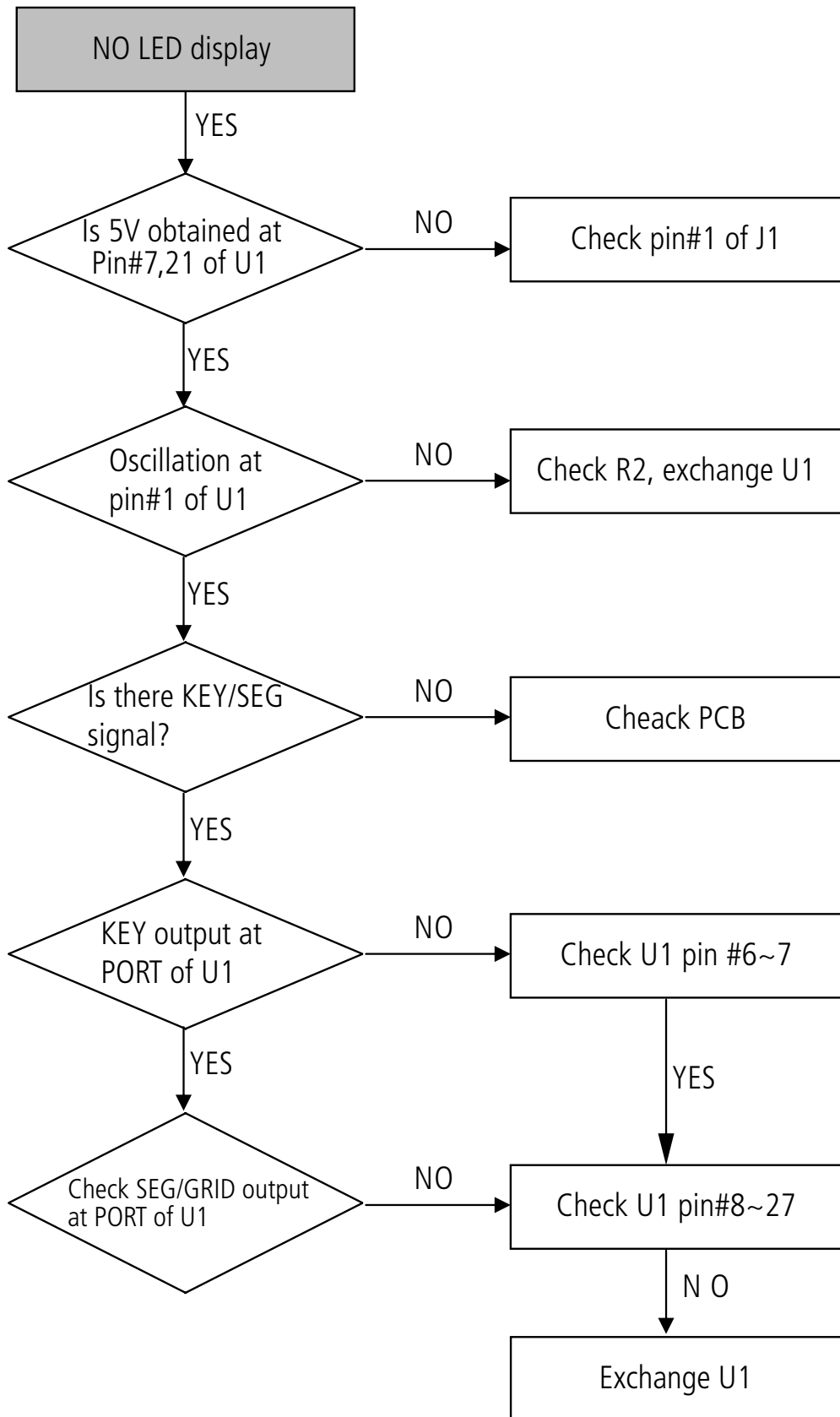

3. VIDEO CIRCUIT

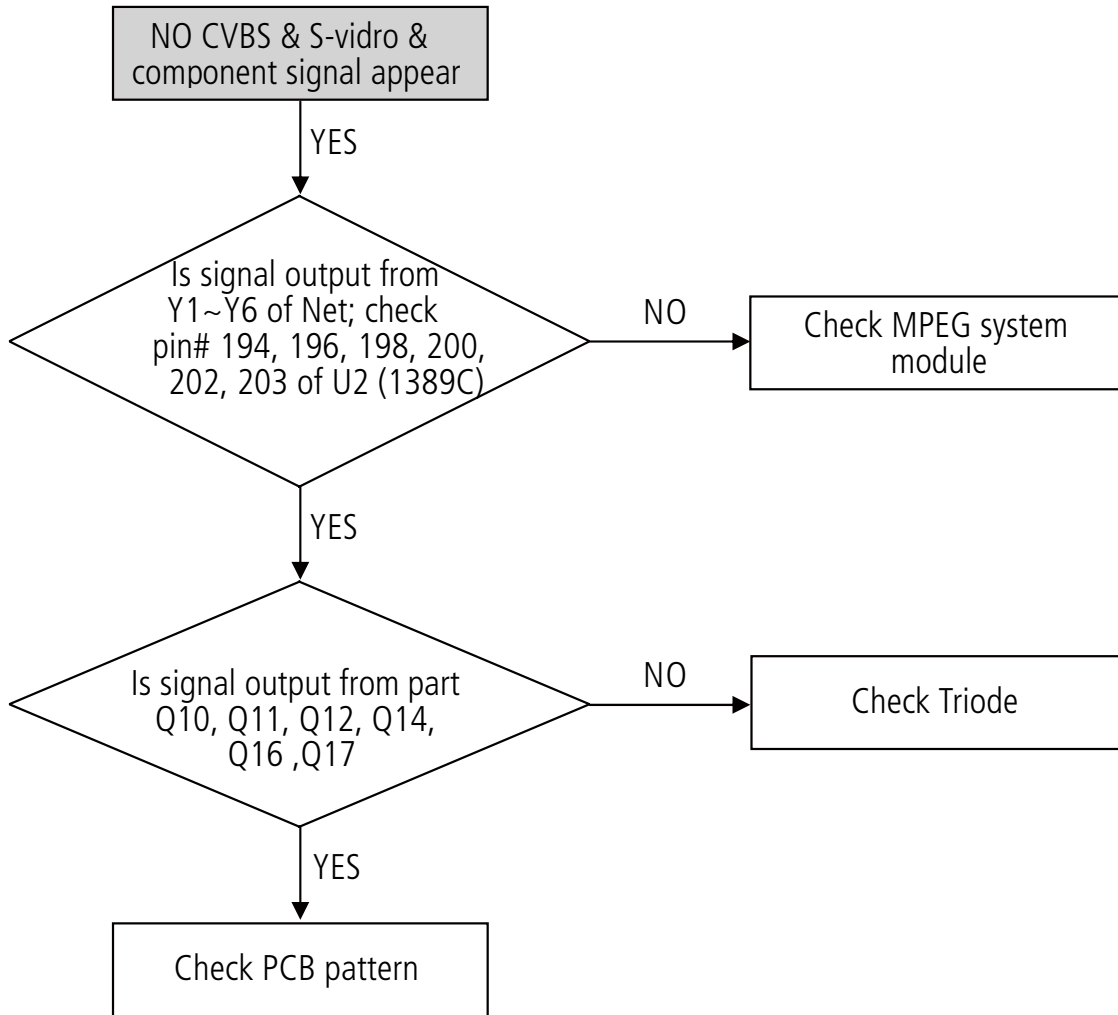

TROUBLE SHOOTING

4. AUDIO OUTPUT CIRCUIT

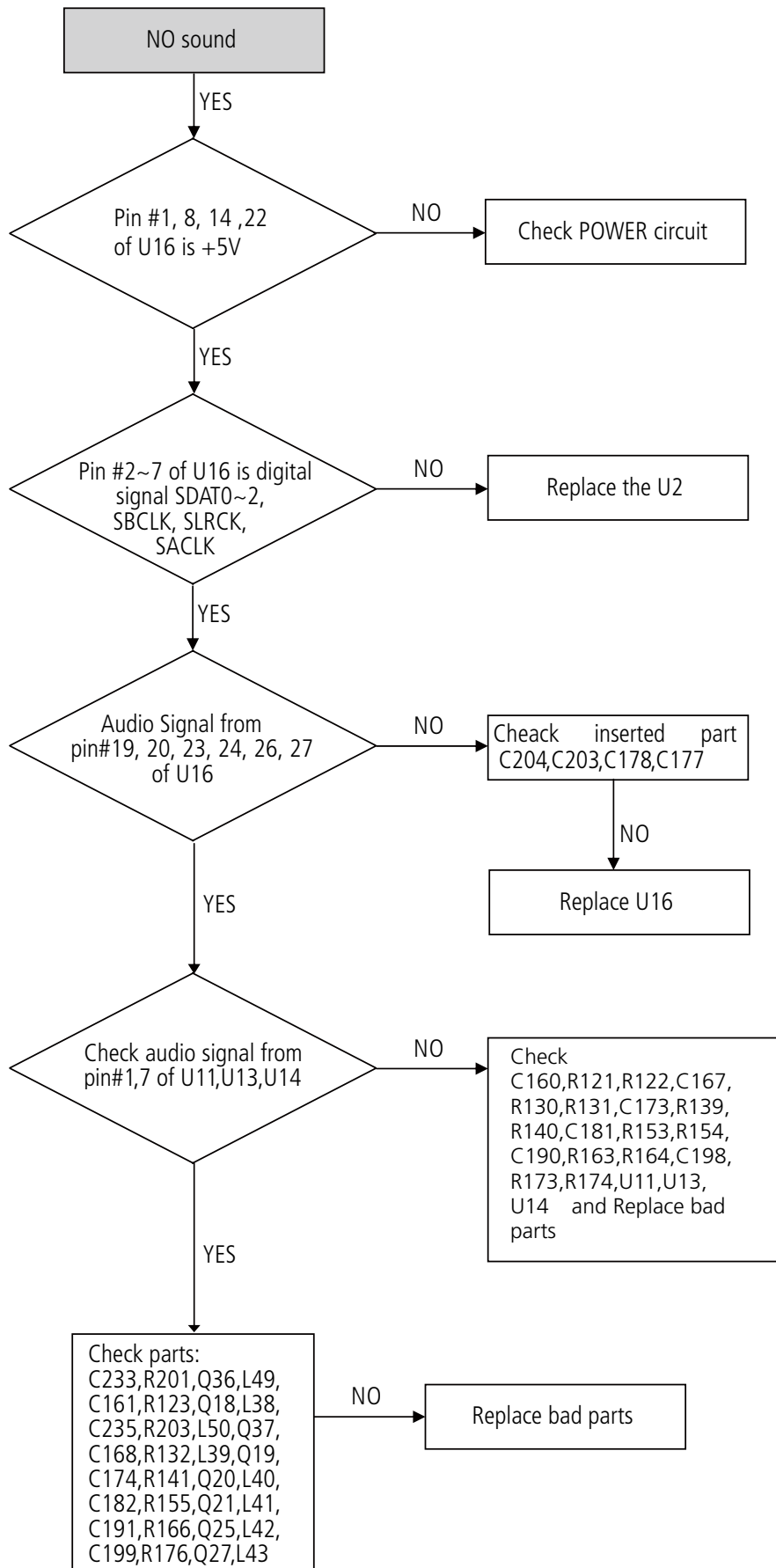

5. MPEG BOARD

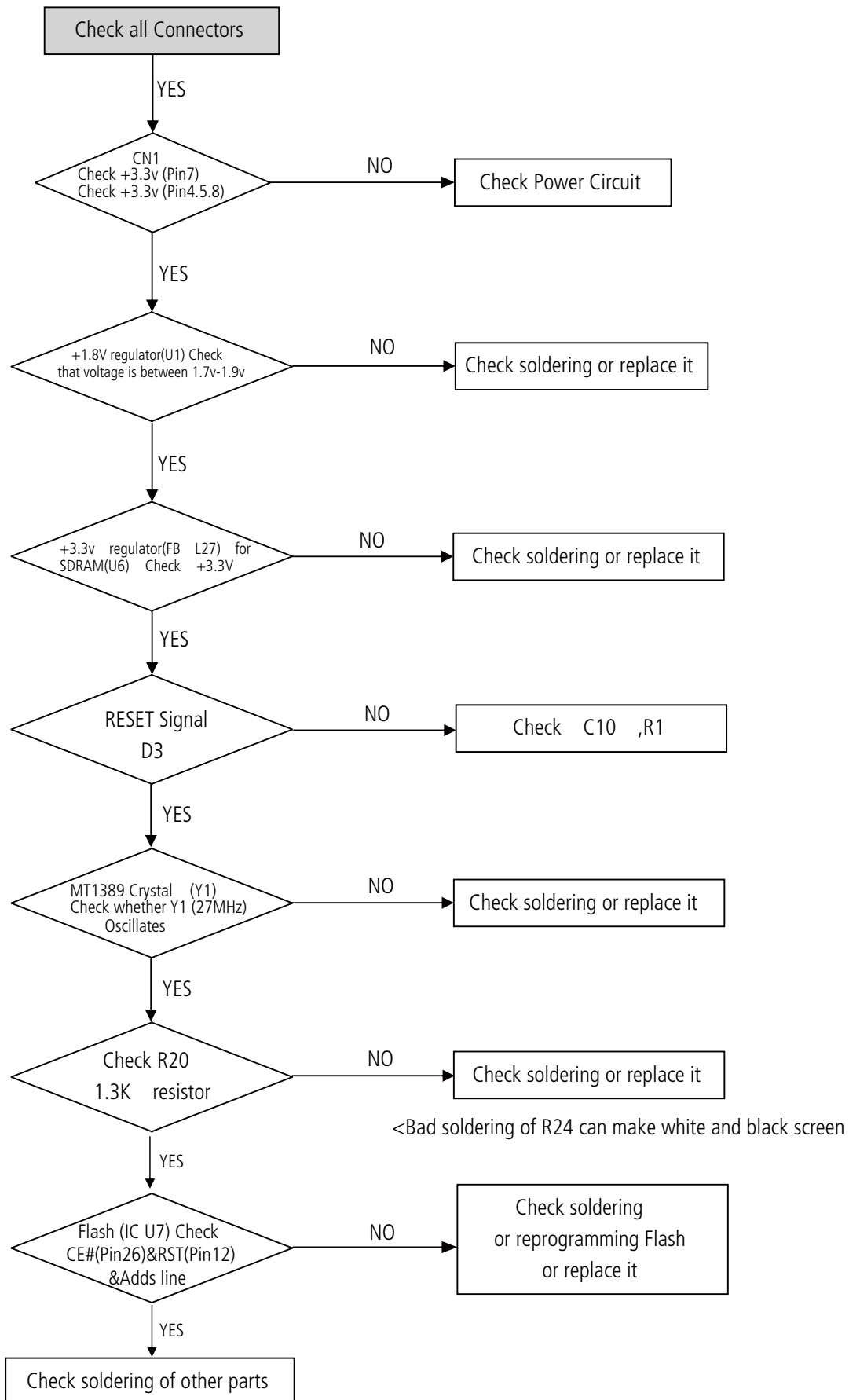

INSTRUMENT DISASSEMBLY

Perform all disassembly procedures in the order presented.
When reassembling, use the reverse procedure.
Make sure that all leads/ wiring are routed correctly when reassembling.

A. TOP COVER REMOVAL

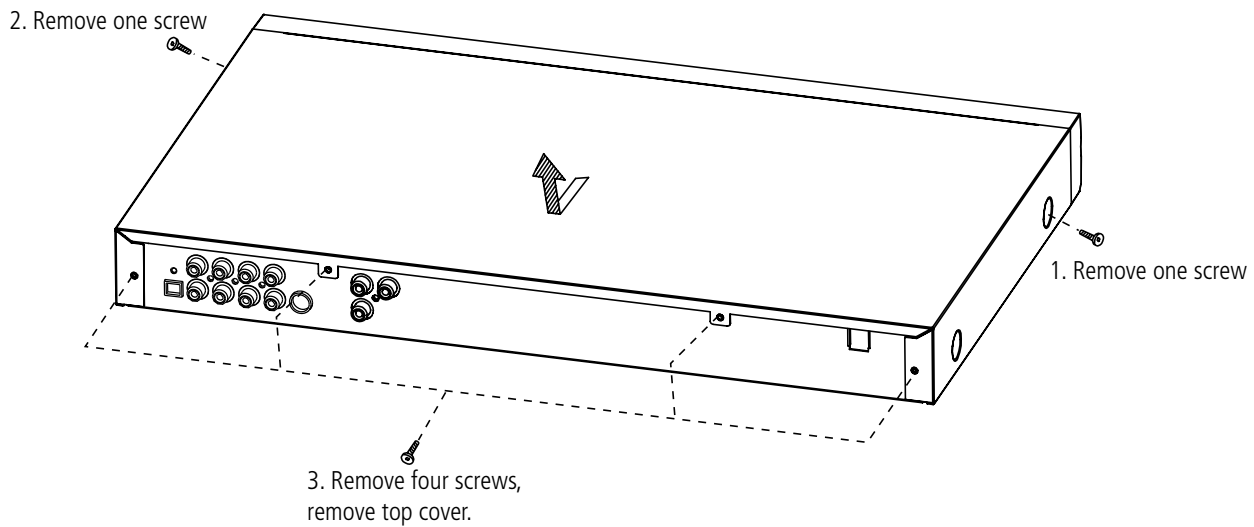
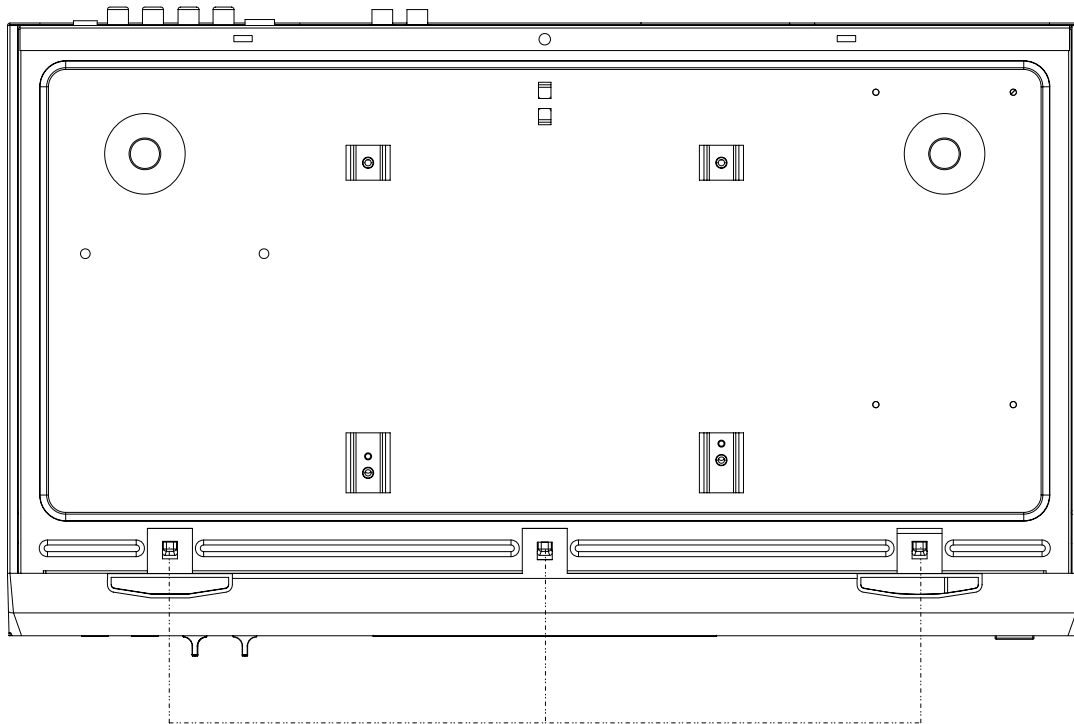

FIG. 1



INSTRUMENT DISASSEMBLY

B. FRONT PANEL DISASSEMBLY



Remove three hooks

Remove two hooks,
remove panel.

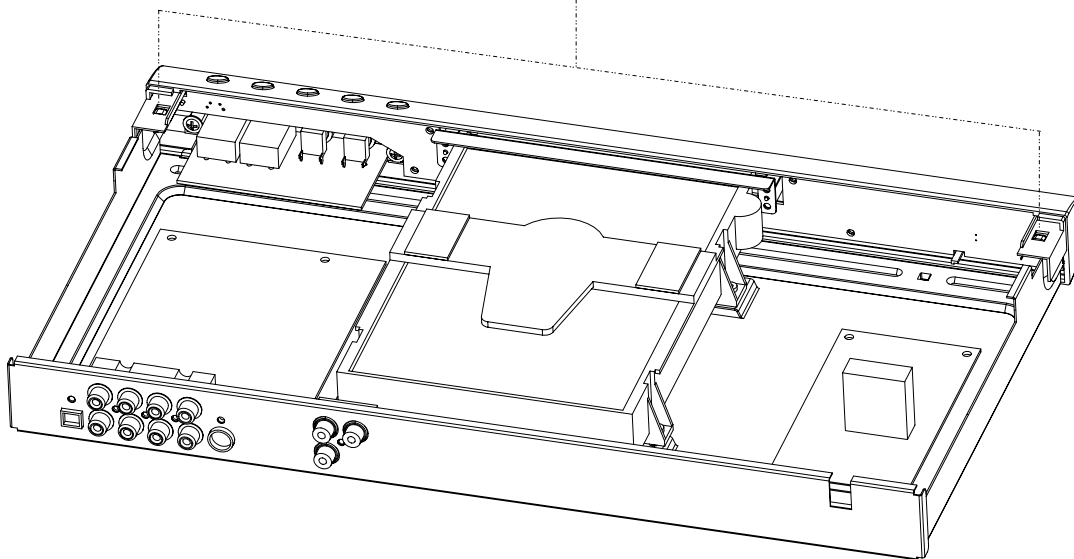

FIG. 2



INSTRUMENT DISASSEMBLY

C. DECODE BOARD DISASSEMBLY

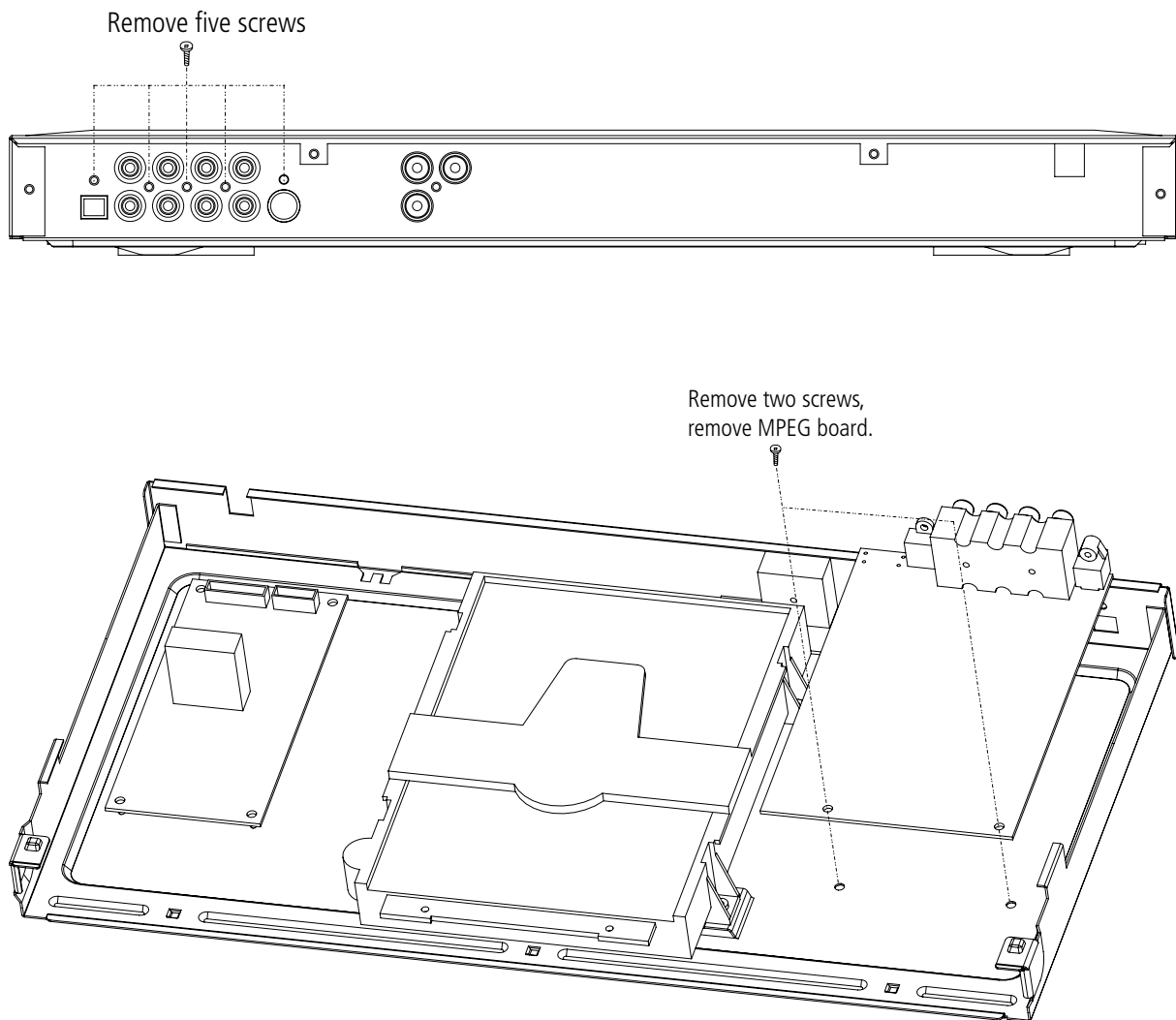

FIG. 3

D. POWER SUPPLY BOARD DISASSEMBLY

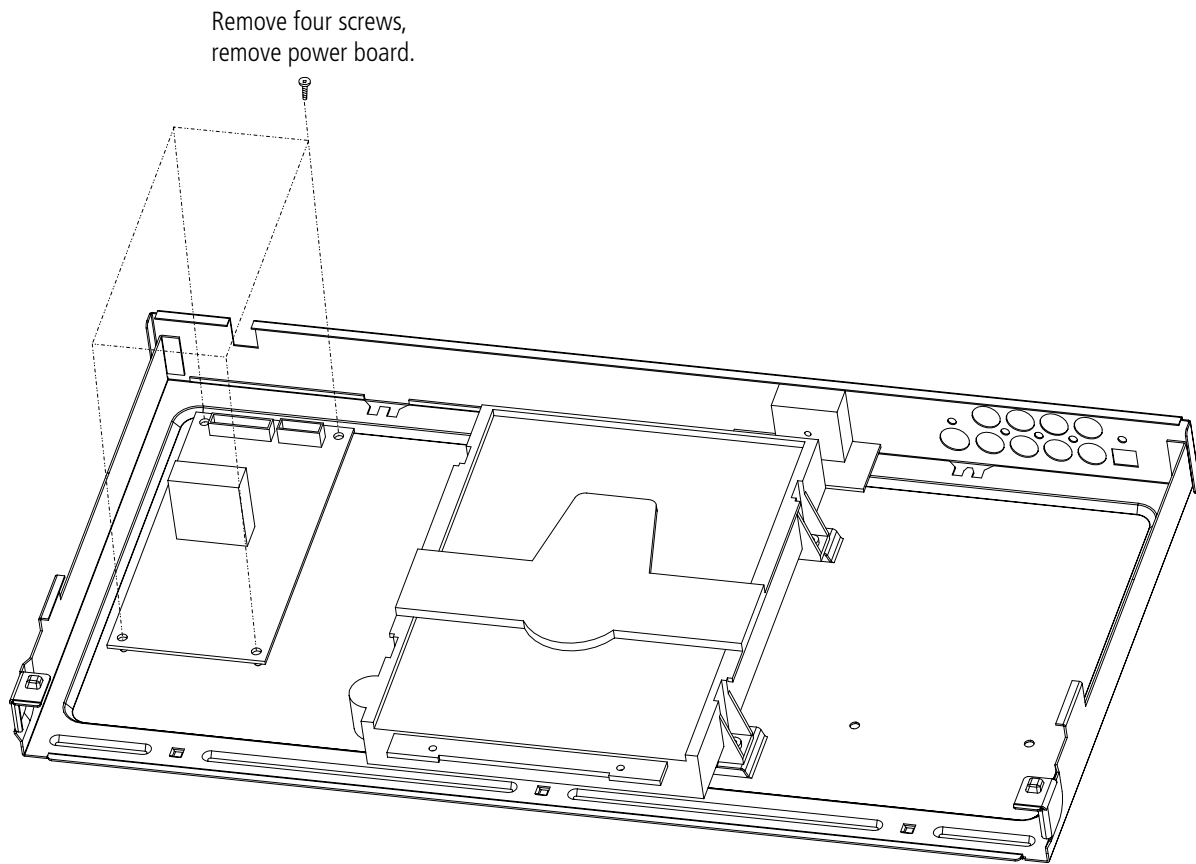

FIG. 5



INSTRUMENT DISASSEMBLY

E. YUV OUTPUT BOARD DISASSEMBLY

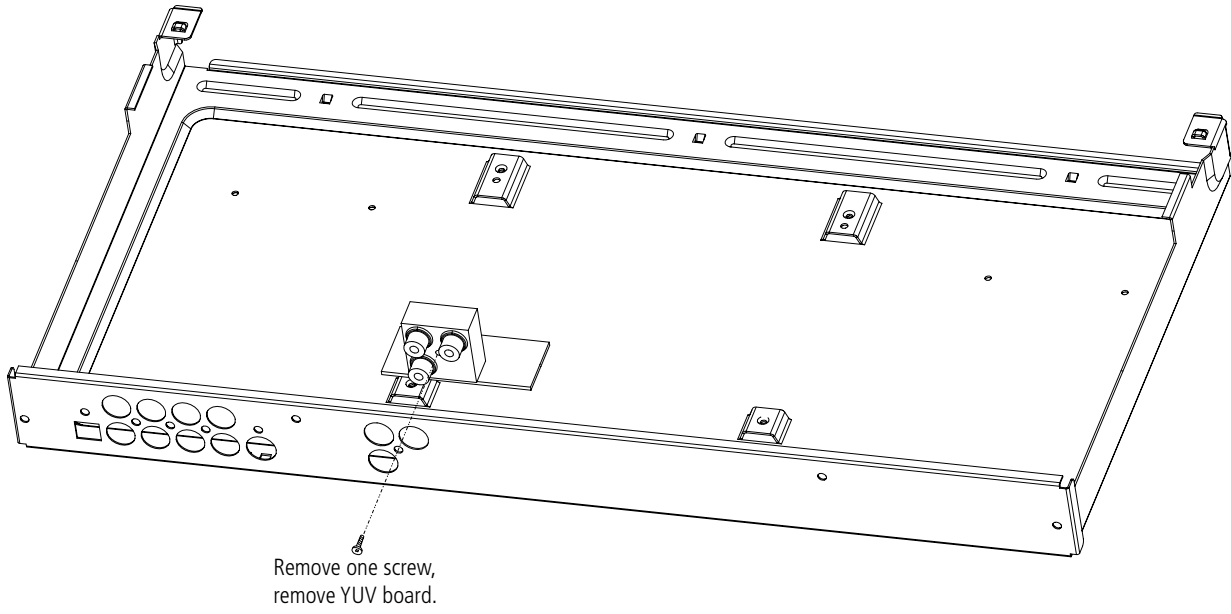

FIG. 6



F. DVD LOADER DISASSEMBLY

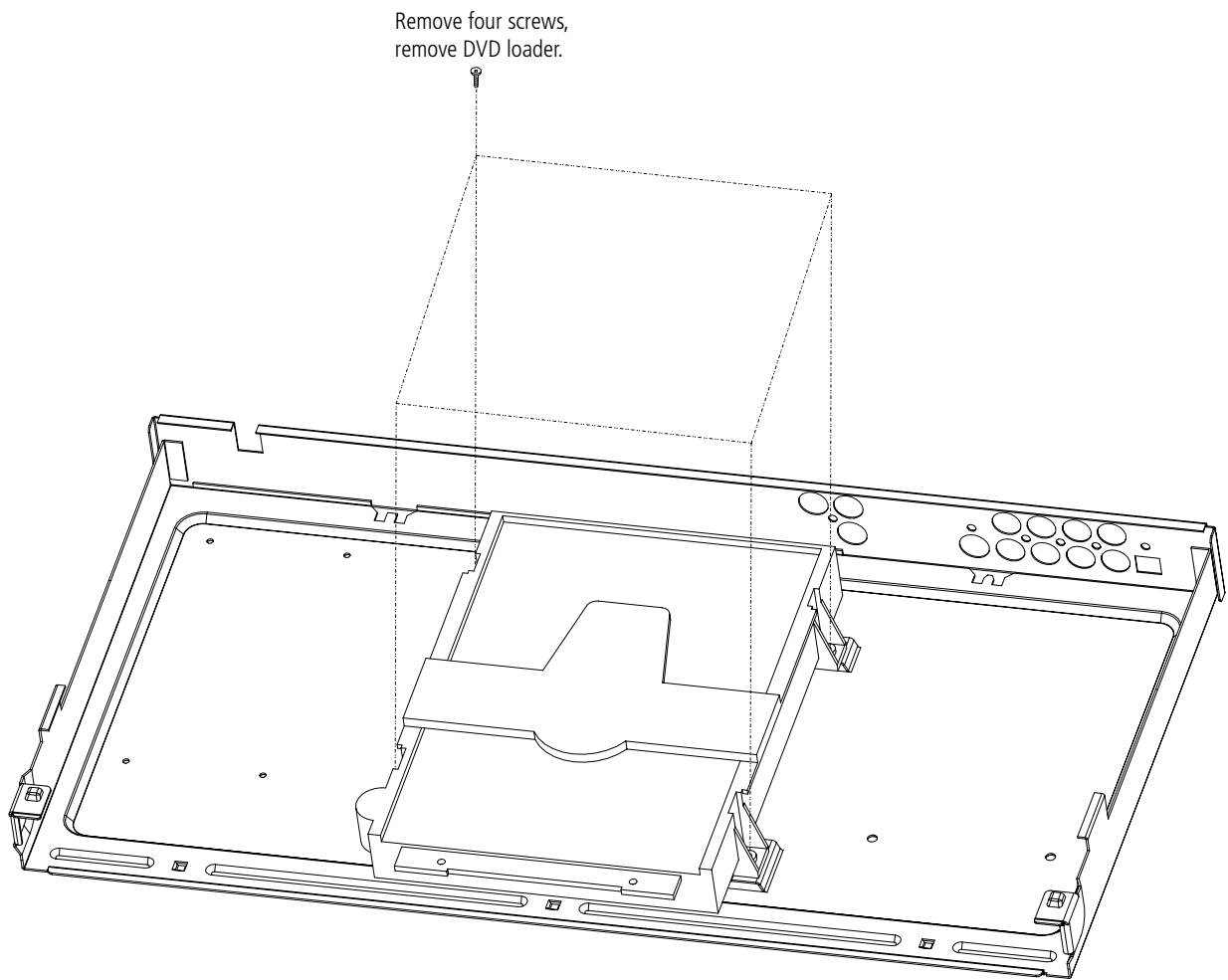

FIG. 7

INSTRUMENT DISASSEMBLY

G. REAR PANEL DISASSEMBLY

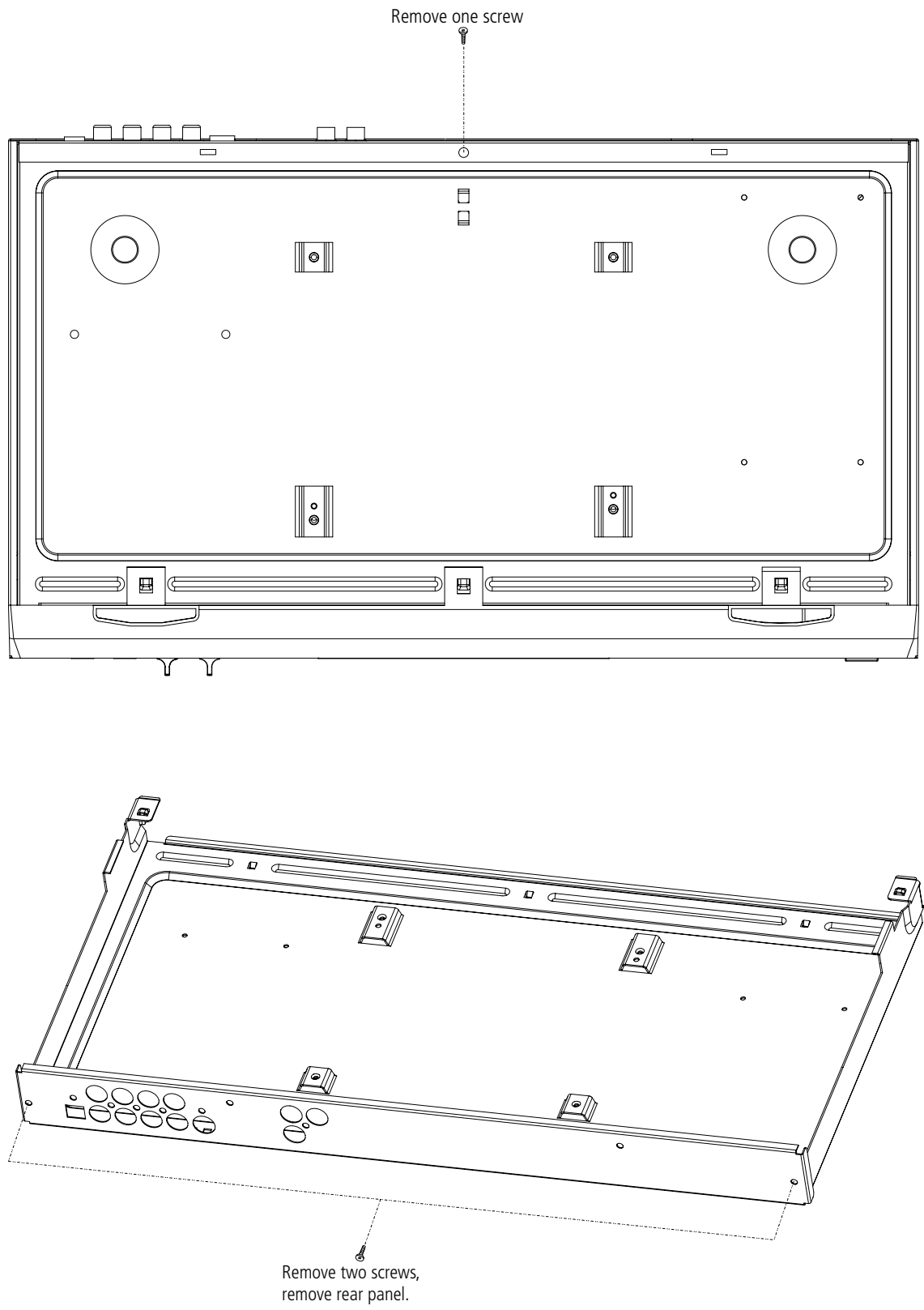

FIG. 8

PARTSLIST

SET Material List

Code: 6020629 (DG-K511S)

Unit:pcs

No	Part Code	Part Name	SPEC	QTY	Location
1	0900001	Battery	7# no Hg	2.0	
2	1100001	Ferrite Core	outside 28mm inside 16mm high7.5mm	1.0	power cord need process
3	1270001	Tie	black tie 120mm	1.0	for power cord
4	1270002	Tie	nylon tie 80mm	3.0	
5	1310141	Conn Wire	2.54 double 9P*350mm,red white conn wire ,reverse	1.0	
6	1310362	Conn Wire	2.0double 11P/9P*120mm,red white conn wire with 1,2P	1.0	from pmeg to loader
7	1350048	Power Cord	2pin UL report)(outside 1.5m 350*15mmwith ferrite core)	1.0	
8	1360001	AV Cable	audio 4pin red white cable 1.5m	1.0	
9	1360002	AV Cable	video 2pin yellow cable 1.5m	1.0	
10	1640046	DVD loader	shinwa loader SHD-2503CWJ-03 HOP-1200W OPU(with reverse OPU conn wire 0.5mm/24P 200mm)	1.0	
11	2010105	CD door	GVG-1/3/6/9 CD door (3815silver have Progressive Scan printing)	1.0	
12	2300179	Mirror	DG-K511S	1.0	
13	2500001	Handle	white handle	1.0	
14	3000123	T/Cover	GVG-3/6/7/8/9(silver)with new DAEWOO	1.0	
15	3010133	B/Cover	GVG-1-MTK(xinhua loader)-yingfeiling power pcb	1.0	
16	3020306	R/Panel	DG-K511S 5.1CH MTK1389C	1.0	
17	3500004	Screw	BTPW3*8	4.0	loader
18	3500005	Screw	BB3*8	5.0	audio5
19	3500007	Screw	BTPW3*6	6.0	T/Cover6
20	3500011	Screw	BB3*10	1.0	YUV 1
21	3500058	Screw	BM3*6	6.0	power pcb4 ,mpeg pcb 2
22	3500103	Screw	BTPW3*4	1.0	R/Panel
23	3670003	Cushion	thickness1.0mm dia3mm	2.0	
24	4050526	Gift Box	DG-K511S(Panama)	1.0	
25	4500077	Pad Foam	GVG-2 left foam	1.0	
26	4500078	Pad Foam	GVG-2 right foam	1.0	
27	4500090	Pad Foam	DVD small foam 200*40*23mm	1.0	near CD door
28	4500093	Pad Foam	DVD small foam 260*50*18mm	1.0	above panel
29	4600005	PE Bag	manual PE bag 04*230*370mm	1.0	
30	4600029	PE Bag	poly bag 350*500mm	1.0	
31	5000046	Masking Tape	15mm*10mm	1.0	for conn wire (mpeg pcb)
32	5000047	Masking Tape	50mm*10mm	1.0	for conn wire (base)
33	5000070	Aluminum Foil Sheet	100*15mm	1.0	for conn wire
34	5300692	Manual	DG-K511S 2rd edition	1.0	
35	5420137	W/Card	DAEWOO (DEAM-FL)according to buyer's PO 2rd edition	1.0	for DEAM-FL buyer
36	5420138	W/Card	DAEWOO(DEPASA)according to buyer's PO 2rd edition	1.0	for DEPASA buyer
37	5440073	Cushion	3816 front cushion 46.6*6.6*8mm(single has sticker)rigidity64	2.0	
38	5440074	Cushion	3816 rear cushion dia15.5mm,thickness 3mm(single has sticker)rigidity64	2.0	
39	5440129	Cushion	20x10x2mm(single has sticker)EVI rigidity60	2.0	loader
40	5450002	PVC Sheet	90x70x0.5mmPVC(single has sticker)	1.0	near transformer
41	5450112	PVC Sheet	81x68x0.65mmPVC(single has sticker)	1.0	near T/Cover
42	5750046	Power PCB Assy	GV-ICE2A0565A-LED-03 (NO STANDBY)	1.0	
43	5760021	YUV PCB Assy	GV-PDV950YUV13	1.0	
44	5780300	F/Panel Assy	DG-K511S(silver)	1.0	
45	5800448	MPEG PCB Assy	DG-K511S MTK1389C-MMTK005-B2-02 (5700260) shinwa	1.0	single stick mpeg skd pack
46	5900204	Remote Control	RC501-A00-(DVG-8500N)	1.0	

PARTSLIST

Code: 6020632 (DG-K513S)

No	Part Code	Part Name	SPEC	QTY	Location
1	0900001	Battery	7# NO Hg	2.0	
2	1100001	Ferrite Core	outside 28mm inside 16mm high7.5mm	1.0	power cord need process
3	1270001	Tie	black tie 120mm	1.0	for power cord
4	1270002	Tie	nylon tie 80mm	3.0	
5	1310141	Conn Wire	2.54 double 9P*350mm,red white conn reverse.	1.0	
6	1310362	Conn Wire	2.0 double 11P/9P*120mm,red white conn wire with 1,2P	1.0	
7	1350048	Power Cord	2pin UL report (outside 1.5m 350*15mm with ferrite core)	1.0	
8	1360001	AV Cable	audio 4pin red white cable 1.5m	1.0	
9	1360002	AV Cable	video 2pin yellow cable 1.5m	1.0	
10	1640046	DVD loader	shinwa loader SHD-2503CWJ-03 HOP-1200W OPU(with reverse OPU conn wire 0.5mm/24P 200mm)	1.0	
11	2010105	CD Door	GVG-1/3/6/9 CD door (3815silver have Progressive Scan print)	1.0	
12	2300182	Mirror	DG-K513S	1.0	
13	2500001	Handle	white handle	1.0	
14	3000123	T/Cover	GVG-3/6/7/8/9(silver)added DAEWOO	1.0	
15	3010135	B/Cover	GVG-3//6/7/9-MTK(shinwaw)- yingfeiling power pcb	1.0	
16	3020308	R/Panel	DG-K513S 5.1CH MTK1389C	1.0	
17	3500004	Screw	BTPW3*8	4.0	loader
18	3500005	Screw	BB3*8	5.0	audio 5
19	3500007	Screw	BTPW3*6	6.0	T/Cover 6
20	3500011	Screw	BB3*10	1.0	YUV 1
21	3500058	Screw	BM3*6	6.0	power pcb 4 MPEG PCB 2
22	3500103	Screw	BTPW3*4	1.0	R/Panel
23	3670003	Cushion	thickness 1.0mm dia 3mm	2.0	
24	4050530	Gift Box	DG-K513(Miami)	1.0	
25	4500077	Pad Foam	GVG-2 left foam	1.0	
26	4500078	Pad Foam	GVG-2 right foam	1.0	
27	4500090	Pad Foam	DVD small foam 200*40*23mm	1.0	near CD door
28	4500093	Pad Foam	DVD small foam 260*50*18mm	1.0	above panel
29	4600005	PE Bag	manual PE bag 04*230*370mm	1.0	
30	4600029	PE Bag	poly bag 350*500mm	1.0	
31	5000046	Masking Tape	15mm*10mm	1.0	for conn wire (mpeg)
32	5000047	Masking Tape	50mm*10mm	1.0	for conn wire (base)
33	5000070	Aluminum Foil Sheet	100*15mm	1.0	for connwire of loader
34	5300568	Manual	DG-K513S(Miami)	1.0	
35	5420137	W/Card	DAEWOO(DEAM-FL)according to buyer PO 2rd edition	1.0	DEAM-FL for PO
36	5420138	W/Card	DAEWOO (DEPASA)according to buyer PO 2rd edition	1.0	DEPASA for PO
37	5440073	Cushion	3816 front cushion 46.6*6.6*8mm(single has sticker)rigidity 64	2.0	
38	5440074	Cushion	3816 rear cushion dia 15.5mm, thickness 3mm(single has sticker)rigidity64	2.0	
39	5440129	Cushion	20x10x2mm(single has sticker)EVI rigidity 60	2.0	loader
40	5450002	PVC Sheet	90x70x0.5mmPVC(single has sticker)	1.0	near transformer
41	5750046	Power PCB Assy	GV-ICE2A0565A-LED-03 (NO STANDBY)	1.0	
42	5760021	YUV PCB Assy	GV-PDV950YUV13	1.0	
43	5780275	F/Panel Assy	DG-K513S (silver)	1.0	
44	5800453	MPEG PCB Assy	DG-K513S MTK1389C-MMTK005-B2-02 (5700260) shinwa	1.0	single stick mpeg
45	5900204	Remote Control	RC501-A00-(DVG-8500N)	1.0	

PARTSLIST

Code: 6020596 (DG-K516S)

No	Part Code	Part Name	SPEC	QTY	Location
1	0900001	Battery	7# no Hg	2.0	
2	1100001	Ferrite Core	outside 28mm inside 16mm high 7.5mm	1.0	power cord need process
3	1270001	Tie	black tie 120mm	1.0	for power cord
4	1270002	Tie	nylon 80mm	3.0	
5	1310141	Conn Wire	2.54 double 9P*350mm,red white conn wire ,reverse	1.0	
6	1310362	Conn Wire	2.0 double 11P/9P*120mm,red white conn wire 1,2P	1.0	from pmeg to loader
7	1350048	Power Cord	2pin UL report (outside 1.5m 350*15mm with ferrite core)	1.0	
8	1360001	AV Cable	audio 4pin red white cable 1.5m	1.0	
9	1360002	AV Cable	video 2pin yellow cable 1.5m	1.0	
10	1640046	DVD loader	shinwa loader SHD-2503CWJ-03 HOP-1200W OPU (with reverse OPU conn wire 0.5mm/24P 200mm)	1.0	
11	2010105	CD Door	GVG-1/3/6/9 CD door (3815silver have Progressive Scan printing)	1.0	
12	2300157	Mirroe	DG-K516S left mirror	1.0	
13	2300160	Mirroe	DG-K516S LED	1.0	
14	2300170	Mirroe	DG-K516S right mirror	1.0	
15	2500001	Handle	white handle	1.0	
16	3000123	T/Cover	GVG-3/6/7/8/9(silver)with new DAEWOO	1.0	
17	3010135	B/Cover	GVG-3//6/7/9-MTK(shinwa)-yingfeiling power pcb	1.0	
18	3020290	R/Panel	DG-K516S 5.1CH MTK1389C	1.0	
19	3500004	Screw	BTPW3*8	4.0	loader
20	3500005	Screw	BB3*8	5.0	audio 5
21	3500007	Screw	BTPW3*6	6.0	T/Cover 6
22	3500011	Screw	BB3*10	1.0	YUV 1
23	3500058	Screw	BM3*6	6.0	power pcb 4 MPEG PCB 2
24	3500103	Screw	BTPW3*4	1.0	R/Panel
25	3670003	Cushion	thickness1.0mm dia3mm	2.0	
26	4050500	Gift Box	DG-K516S	1.0	
27	4500077	Pad Foam	GVG-2 left foam	1.0	
28	4500078	Pad Foam	GVG-2 right foam	1.0	
29	4500090	Pad Foam	DVDsmall foam 200*40*23mm	1.0	near CD door
30	4500093	Pad Foam	DVD small foam 260*50*18mm	1.0	above panel
31	4600005	PE Bag	manual PE bag 04*230*370mm	1.0	
32	4600006	PE Bag	remote control PE bag 04*80*260mm	1.0	
33	4600029	PE Bag	poly bag 350*500mm	1.0	
34	5000046	Masking Tape	15mm*10mm	1.0	for conn wire (mpeg)
35	5000047	Masking Tape	50mm*10mm	1.0	for conn wire (base)
36	5000070	Aluminum Foil Sheet	100*15mm	1.0	for connwire of loader
37	5300528	Manual	DG-K516S	1.0	
38	5420137	W/Card	DAEWOO(DEAM-FL)according to buyer's PO 2rd edition	1.0	DEAM-FL for PO
39	5420138	W/Card	DAEWOO(DEPASA)according to buyer's PO 2rd edition	1.0	DEPASA for PO
40	5440073	Cushion	3816front cushion46.6*6.6*8mm(single has sticker)rigidity64	2.0	
41	5440074	Cushion	3816rear cushion dia 15.5mm,thickness3mm(single has sticker)rigidity64	2.0	
42	5440129	Cushion	20x10x2mm(single has sticker)EVI rigidity60	2.0	loader
43	5450002	PVC Sheet	90x70x0.5mmPVC(single has sticker)	1.0	near transformer
44	5450112	PVC Sheet	81x68x0.65mmPVC(single has sticker)	1.0	mic pcb
45	5750046	Power PCB Assy	GV-ICE2A0565A-LED-03 (NO STANDBY)	1.0	
46	5760021	YUV PCB Assy	GV-PDV950YUV13	1.0	
47	5780276	F/Panel Assy	DG-K516S (silver)	1.0	
48	5800426	MPEG PCB Assy	DG-K516S MTK1389C-MMTK005-B2-02 (5700260) shinwa	1.0	single stick mpeg
49	5900204	Remote Control	RC501-A00-(DVG-8500N)	1.0	

PARTSLIST

MPEG PCB Assy Material List

Code: 5700260

No	Part Code	Part Name	SPEC	QTY	Location
1	0000164	R Carbon Film	1W 3.3E ±5%	1.0	R46
2	0050001	R Chip	1/16w 0E ±5% 0603	12.0	R59.R69.R70.R10.R18.R19.R47.R49.R5,[2Mx16 SDRAM(R8,R71,R216)O type,(R8,R71,R211)P type,(R8,R214,R217)R type,(R8,R212,R214)S type],[1Mx16 SDRAM(R71,R72))
3	0050002	R Chip	1/16w 10E ±5% 0603	8.0	R32.R127.R22.R21.R45.R33.R43.R190
4	0050004	R Chip	1/16w 33E ±5% 0603	9.0	R151.R144.R73.R142.R149.R150.R143.R74.R210
5	0050006	R Chip	1/16w 75E ±5% 0603	7.0	R207.R107.R85.R114.R95.R206.R208
6	0050007	R Chip	1/16w100E ±5% 0603	1.0	R113
7	0050008	R Chip	1/16w110E ±5% 0603	1.0	R115
8	0050010	R Chip	1/16w160E ±5% 0603	12.0	R100.R82.R87.R109.R89.R92.R111.R80.R90.R102.R98.R104.
9	0050019	R Chip	1/16w 1K ±5% 0603	14.0	R12.R126.R135.R196.R132.R123,R141,R148,R155,R158,R166,R170,R176,R180
10	0050021	R Chip	1/16w2.2K ±5% 0603	1.0	R177
11	0050028	R Chip	1/16w 10K ±5% 0603	20.0	R61,R161.R195.R62.R160.R121.R65.R167.R68.R75.R130.R79.R192.R1.R29.R3,R139,R153,R163,R173
12	0050031	R Chip	1/16w 15K ±5% 0603	2.0	R13.R53
13	0050033	R Chip	1/16w 20K ±5% 0603	7.0	R118.R128,R136,R152,R159,R172,R54
14	0050034	R Chip	1/16w 22K ±5% 0603	2.0	R129.R120
15	0050035	R Chip	1/16w 47K ±5% 0603	2.0	R52.R51
16	0050036	R Chip	1/16w100K ±5% 0603	14.0	R191.R134.R4.R198.R7.R162.R125.R193.R171.R197,R147,R157,R169,R179
17	0050042	R Chip	1/16w6.8K ±5% 0603	1.0	R175
18	0050044	R Chip	1/16w6.8E ±5% 0603	1.0	R199
19	0050050	R Chip	1/16w 22E ±5% 0603	2.0	R116,R117
20	0050051	R Chip	1/16w 1E ±5% 0603	1.0	R20
21	0050053	R Chip	1/16w4.7E ±5% 0603	1.0	R119
22	0050054	R Chip	1/16w750K ±5% 0603	1.0	R2
23	0050056	R Chip	1/16w680E ±5% 0603	2.0	R77.R78
24	0050071	R Chip	1/16w 5.1K±5% 0603	6.0	R122.R131,R140,R154,R164,R174
25	0050089	R Chip	1/16w 1K ±1% 0603	1.0	R30
26	0050097	R Chip	1/16w1.2K ±5% 0603	1.0	R24
27	0050110	R Chip	1/16w 150K ±5% 0603	2.0	R15.R17
28	0050127	R Chip	1/16w 680E ±1% 0603	1.0	R23
29	0050135	R Chip	1/16w 180K ±5% 0603	6.0	R124.R133,R146,R156,R168,R178
30	0050136	R Chip	1/16w 680K ±5% 0603	2.0	R9.R14
31	0050140	R Chip	1/16w 150E ±1% 0603	6.0	R106.R97.R94.R86.R108.R84
32	0060002	R Chip Array	1/16w33E*4±5% 0603	1.0	RN1
33	0190013	C Electro	16V 220UF ±20% D6	13.0	C3.C206.C19.C11.C113.C8.C2.C15.C104.C13.C4.C17.C223
34	0190014	C Electro	16V 22UF ±20%	1.0	C227
35	0190022	C Electro	16V 47UF ±20% D5	9.0	C100.C143.C49.C120.C51.C50.C122.C77.C75
36	0190030	C Electro	16V 100UF ±20% D5	5.0	C57.C225.C159.C165.C69
37	0190031	C Electro	50V 3.3UF ±20%	2.0	C177.C203
38	0190033	C Electro	25V 10UF ±20% D5	17.0	C167.C31.C32.C231.C168.C161.C154.C160.C10,C173,C181,C190,C198,C174,C182,C191,C199
39	0190126	C Electro	16V 470UF ±20% D6.3	2.0	C185.C205
40	0200003	C Chip	22P 50V ±10% 0603	1.0	C232
41	0200004	C Chip	102 50V ±10% 0603	4.0	C208.C207.C33.C38
42	0200005	C Chip	27P 50V ±10% 0603	1.0	C156
43	0200008	C Chip	101 50V ±10% 0603	3.0	C230.C209.C61

PARTSLIST

No	Part Code	Part Name	SPEC	QTY	Location
44	0200012	C Chip	221 50V ±10% 0603	6.0	C157.C166,C172,C180,C189,C197
45	0200015	C Chip	153 50V ±10% 0603	1.0	C92
46	0200016	C Chip	333 50V ±10% 0603	1.0	C42
47	0200021	C Chip	1U 10V ±10% 0603	8.0	C43.C44.C59.C60.C62.C63.C64.C291
48	0200026	C Chip	68P 50V ±10% 0603	6.0	C170.C163.C176,C184,C196,C201
49	0200031	C Chip	473 50V ±10% 0603	2.0	C45.C46
50	0200032	C Chip	222 50V ±10% 0603	9.0	C30.C24.C222,C162.C169,C175,C183,C195,C200
51	0200041	C Chip	152 50V ±10% 0603	1.0	C74
52	0201006	C Chip	391 50V ±5% 0603	1.0	C21
53	0201009	C Chip	20P 50V ±5% 0603	1.0	C26
54	0201011	C Chip	331 50V ±5% 0603	2.0	C90.C89
55	0201012	C Chip	33P 50V ±5% 0603	2.0	C27.C28
56	0201033	C Chip	47P 50V ±5% 0603	12.0	C149.C133.C139.C134.C131.C151.C152.C150.C132,C142.C141.C140
57	0202001	C Chip	0.1U 50V +80%-20% 0603	93.0	105~112,114~119,20,9,85,178~179,14,12,67,16,1,6~7,123~128,18,121,52~56,186~188,158,29,86~88,76,153,135~136,5,171,78~83,39~41,91,84,34~37,23,99,66,71~73,58,164,144~146,103,192~194,155.94~97,204,220~221.224.226
58	0206002	C Chip	474 50V ±10% 0805	1.0	C47
59	0250018	Coil	(0805)10UH((SDFL2012S100KT)	2.0	L23.L24
60	0250020	Coil	(0805)1.8UH(SDFL2012Q1R8KT)	6.0	L30.L31.L34.L35.L36.L37
61	0250028	Coil	(0805) FB(PZ2012U601-2ROT)	28.0	L15.L2.L26.L38.L7.L45.L8.L46.L21.L17.L44,L22.L4.L32.L3.L25.L1.L39.L6.L27.L20.L9.L5,L40,L41,L42,L43,(L28(5V)orL29(3.3V)Flash)
62	0250072	Coil	(0805)2.7UH(SDFL2012Q2R7KT)	1.0	L13
63	0390001	Diode Chip	1N4148	17.0	D3~D19.
64	0460001	TR Chip	2N3904	9.0	Q19.Q34.Q24.Q18.Q35,Q20,Q21,Q25,Q27
65	0460006	TR Chip	SS8550 (SOT23)	2.0	Q4.Q5
66	0460007	TR Chip	2N3906 (SOT23)	11.0	Q10.Q14.Q12.Q11.Q16.Q32.Q33.Q22.Q23.Q17.Q1
67	0510130	IC	F4558S (SOP)	3.0	U11,U13,U14
68	0510131	IC	CS4360	1.0	U16
69	0510146	IC	AT24C16AN(SOP)	1.0	U9
70	0510195	IC	AMS1117-ADJ (SOT-223)	1.0	U1
71	0510316	IC	AE39S2016-7 TRI-ZIP 2*16M	1.0	U6
72	0510350	IC	AM5668S	1.0	U3
73	0510369	IC	MT1389DE RVE:C	1.0	U2
74	0510684	IC	ES29LV160DB-70TG 3.3V 48Pin "EXCELSEMI" no lead	1.0	U7
75	0610010	Crystal	27MHz 27P (HC-49/S)	1.0	Y1
76	1000438	PCB	MMTK005 REV:B2.2 mpeg pcb	1.0	
77	1150003	Conn Wafer	XH-4Pin 2.54mm	1.0	CN9
78	1150005	Conn Wafer	XH-6Pin 2.54mm	1.0	CN5
79	1150035	Conn Wafer	XH-6Pin 2.0mm	1.0	CN7
80	1150037	Conn Wafer	XH-4Pin 2.0mm	1.0	CN6
81	1150039	Conn Wafer	HOP1200/-24Pin 0.5mm horizontal	1.0	CN2
82	1150042	Conn Wafer	XH-11Pin 2.0mm	1.0	CN4
83	1150043	Conn Wafer	XH-9Pin 2.54mm	1.0	CN1
84	1150102	Conn Wafer	8pin AV8-8.4-13D-B	1.0	CP3
85	1150105	Conn Wafer	optical TX179AFT	1.0	CP1
86	1150115	Conn Wafer	S-video(with fixed hole)DSW-007	1.0	CP2

PARTSLIST

POWER PCB Assy Material List

Code: 5750046

NO	Part Code	Part Name	SPEC	QTY	Location
1	0000005	R Carbon Film	1/6W 10K ±5%	1.0	RA8 near ZD2
2	0000121	R Carbon Film	1/8W 1K ±5%	1.0	RB9
3	0000192	R Carbon Film	1/8W 470E ±5%	1.0	RB8
4	0000196	R Carbon Film	1/4W 430K ±5%	2.0	RA2,RA3
5	0000197	R Carbon Film	1/4W 15E ±5%	2.0	RA4,RA5
6	0000199	R Carbon Film	1/8W 5.1K ±5%	2.0	RB11,RB12
7	0000202	R Carbon Film	1W 1E ±5%	1.0	RA6
8	0000203	R Carbon Film	1W 68K ±5%	1.0	RA1
9	0110015	C Cera AC	275V 0.1UF±20% X2(DAIN)	2.0	CA1,CA10
10	0110025	C Cera AC	400VAC 470pF±10% Y1(JEC)	3.0	CY1,CY2,CY3
11	0150015	C Cera	223 50V ±10%	1.0	CA8
12	0150017	C Cera	1KV2200PF ±10% Y5P	1.0	CA4
13	0151009	C Cera	104 50V ±20%	2.0	CB12,CA9
14	0190026	C Electro	10V 220UF ±20%	1.0	CB6
15	0190039	C Electro	25V 22UF ±20% D5	1.0	CA7
16	0190041	C Electro	25V 220UF ±20% D8	1.0	CB9
17	0190045	C Electro	25V 47UF ±20% D6	3.0	CB4,CB10,CA5
18	0190077	C Electro	10V 1000UF ±20% D8	1.0	CB5
19	0190120	C Electro	10V 100UF ±20% D6	2.0	CB7,CB8
20	0190125	C Electro	400V 22UF ±20% D16x22	1.0	CA3
21	0190129	C Electro	25V 100UF ±20% D8	1.0	CB3
22	0190159	C Electro	50V 1UF ±20% D5	1.0	CA6
23	0250006	Coil	RH3.5*4.7*0.8	1.0	LA2
24	0250108	Coil	UT-20 25mH	1.0	LA1
25	0251013	Coil	10UH 0.5A ±10% D5	1.0	LB1
26	0251014	Coil	10uH 3A ±10% D8	1.0	LB2
27	0300024	Transformer	PINF001-L horizontal EEL19	1.0	T1
28	0320005	Diode	1N4007	4.0	DA1~DA4
29	0320026	Diode	RL201 2A50V	2.0	DB7,DB8
30	0330013	Zener Diode	4.3V 1/2W DO-35	1.0	RA9
31	0330023	Zener Diode	12V 1/2W DO-35	1.0	ZDA3
32	0330027	Zener Diode	18V 1/2W DO-35	1.0	ZDA1
33	0380019	Diode Schottky	1N5822 F17mm	1.0	DB3
34	0380022	Diode Schottky	FR105 1A600V	4.0	DB4,DA5,DA6,DB2
35	0510044	IC	TL431ACZ-AP 2.5V line2.54mm no lead	1.0	U3
36	0510475	IC	ICE2A0565A	1.0	U1
37	0510715	IC	ICE2B0565A	1.0	U1
38	0640008	IC Photo Coupler	K1010C (817)COSMO	1.0	U2
39	1000462	PCB	PINF001 REV:B1.3 power pcb 2005-10-22	1.0	
40	1150043	Conn Wafer	XH-9Pin 2.54mm	1.0	CN4
41	1150221	Conn Wafer	XH-2Pin 3.96mm(HX-5273)	1.0	CN1
42	1260006	Jmper	pin distance 10mm	3.0	JP2,JP3,CN2
43	1260007	Jmper	pin distance 12mm	2.0	JP1,RB5
44	1260011	Jmper	pin distance 15mm	1.0	DB6
45	1450006	Fuse	1A 250V UL	1.0	F1
46	1460002	Fuse Jack	metal fuse Jack	2.0	F1
47	3670001	Cushion	iron cushion Ø3.2	1.0	CT

PARTSLIST

Front Panel Assy Material List

Code: 5780300(DG-K511S)

No	Part Code	Part Name	SPEC	QTY	Location
1	1290024	Lead	18# single line 80mm	1.0	
2	2000328	Panel	DG-K511S(silver)	1.0	
3	2100262	Knob	GVG-1 power knob	1.0	
4	2100263	Knob	GVG-1 function knob	1.0	
5	2200042	Knob	3816potentiometern knob(silver)	2.0	
6	3500084	Screw	BB3*8 Ø5	12.0	control pcb8,housing 4
7	3500094	Screw	BTPW3*7(meson dia 9.0mm)	2.0	MIC PCB
8	3900114	Metal Base	GVG-3 panel housing	1.0	
9	5710067	Mic PCB Assy	GV-DMAGVG-5-01	1.0	
10	5730148	Control PCB Assy	GV-DCAGVG-1-LED-01 (NO STANDBY)	1.0	

Code: 5780275(DG-K513S)

No	Part Code	Part Name	SPEC	QTY	Location
1	1290024	Lead	18# single line 80mm	1.0	
2	2000365	F/Panel	DG-K513S	1.0	
3	2100265	Knob	GVG-3 power knob	1.0	
4	2100266	Knob	GVG-3 function knob	1.0	
5	3500081	Screw	BTPW3*8(meson dia 9.0mm)	2.0	MIC PCB
6	3500084	Screw	BB3*8 Ø5	11.0	control pcb 7,housing 4
7	3900114	Metal Base	GVG-3 panel housing	1.0	
8	5710070	MIC PCB Assy	GV-DMAGVG-3-01	1.0	
9	5730143	Control PCB Assy	GV-DCAGVG-3-LED-01 (NO STANDBY)	1.0	

Code: 5780276(DG-K516S)

No	Part Code	Part Name	SPEC	QTY	Location
1	1290024	Lead	18# single lin e80mm	1.0	
2	2000298	F/Panel	GVG-6(silver)	1.0	
3	2100260	Knob	GVG-6 power knob	1.0	
4	2100261	Knob	GVG-6 function knob	1.0	
5	2100267	Knob	GVG-6 close/open knob	1.0	
6	2200034	Knob	8500potentiometer(silver)	2.0	
7	3500010	Screw	BB3*6	2.0	knob
8	3500081	Screw	BTPW3*8(meson dia 9.0mm)	2.0	MIC PCB
9	3500084	Screw	BB3*8 Ø5	10.0	control PCB 6, housing 4
10	3900114	Metal Base	GVG-3 panel housing	1.0	
11	5710066	MIC PCB Assy	GV-DMAGVG-2-01	1.0	
12	5730146	Control PCB Assy	GV-DCAGVG-6-LED-01 (NO STANDBY)	1.0	

PARTSLIST

Control PCB Assy Material List

Code: 5730148(DG-K511S)

No	Part Code	Part Name	SPEC	QTY	Location
1	0000005	R Carbon Film	1/6W 10K ±5%	5.0	R1,R2,R3,R4,R6
2	0000019	R Carbon Film	1/6W 51K ±5%	1.0	R7
3	0000142	R Carbon Film	1/6W 100E ±5%	1.0	R5
4	0150007	C Cera	101 50V ±10%	3.0	C3,C4,C5
5	0152001	C Cera	104 50V -20%+80% F5 D6	1.0	C1
6	0190030	C Electro	16V 100UF ±20% D5	2.0	EC1,C2
7	0340001	LBD	dia 3mm	1.0	LED1
8	0510586	IC	V6928	1.0	U1
9	0711005	LED	LED MR-6659	1.0	U2
10	0800001	Switch	6*6*5	5.0	SW1~SW5
11	1000389	PCB	CGVG027 REV;B2.0 2005-06-18 control pcb	1.0	
12	1100002	Ferrite Core	outside 22.5mm inside 13.8mm, high 6.4mm	1.0	
13	1260002	Jumper	pin distance 5mm	2.0	JMP1,JMP5
14	1260005	Jumper	pin distance 8mm	1.0	JMP3
15	1260006	Jumper	pin distance 10mm	2.0	JMP4,JMP2
16	1310470	Conn Wire	2.54 single 6P*550mm,red white conn wire 2~3,5~6across	1.0	CON1
17	1500003	Receiver	PIC-317LM	1.0	IR1
18	5440077	Cushion	8x8x7mm(double has sticker)EVI	1.0	IR1
19	5440132	Cushion	40x4x7.5mm(double has sticker)EVlrigidity 64	1.0	LED

Code: 5730143(DG-K513S)

No	Part Code	Part Name	SPEC	QTY	Location
01	0000005	R Carbon Film	1/6W 10K ±5%	5.0	R2,R3,R4,R6,R7
03	0000019	R Carbon Film	1/6W 51K ±5%	1.0	R1
02	0000142	R Carbon Film	1/6W 100E ±5%	1.0	R5
19	0100024	Potentiometer	WHE101N-2A-B20KΩ 3pin NO lead	1.0	VR1
18	0100025	Potentiometer	WHE101N-2A-C20KΩ 3pin no lead	1.0	VR2
09	0150007	C Cera	101 50V ±10%	3.0	C4,C5,C3
10	0152001	C Cera	104 50V -20%+80% F5 D6	1.0	C1
08	0190030	C Electro	16V 100UF ±20% D5	2.0	C2,C6
18	0340001	LED	dia 3mm	1.0	LED1
11	0510586	IC	V6928	1.0	U1
12	0711005	LED Array	LED MR-6659	1.0	U2
05	0800001	Switch	6*6*5	6.0	SW1~6
15	1000387	PCB	CGVG033 REV;B2.0 2005-5-19 control pcb	1.0	
18	1100002	Ferrite Core	outside 22.5mm,inside 13.8mm ,high 6.4mm	1.0	
16	1260003	Jumper	pin distance 6mm	3.0	JMP1,JMP3,JMP4
17	1260018	Jumper	pin distance 9mm	1.0	JMP2
04	1310480	Conn Wire	2.54single 5P*120mm,red white conn wire 1,2~3 across	1.0	CN2
06	1310481	Conn Wire	2.54singel 6P*550mm,red white conn wire 1,2~3,5~6 across	1.0	CN1
07	1500003	Receiver	PIC-317LM	1.0	IR
13	5440100	Cushion	8x7x5mm(double has sticker) rigidity64	1.0	IR
14	5440124	Cushion	40x4x5mm(double has sticker)EVI rigidity64	1.0	LED

PARTSLIST

Code: 5730146(DG-K516S)

No	Part Code	Part Name	SPEC	QTY	Location
1	0000005	R Carbon Film	1/6W 10K ±5%	6.0	R1,R3,R4,R5,R6,R8
2	0000019	R Carbon Film	1/6W 51K ±5%	1.0	R2
3	0000142	R Carbon Film	1/6W 100E ±5%	1.0	R7
4	0150007	C Cera	101 50V ±10%	3.0	C3,C4,C5
5	0152001	C Cera	104 50V -20%+80% F5 D6	1.0	C1
6	0190030	C Electro	16V 100UF ±20% D5	2.0	EC1,C2
7	0340001	LBD	dia 3mm	1.0	LED1
8	0510586	IC	V6928	1.0	U1
9	0711005	LED	LED MR-6659	1.0	U2
10	0800001	Switch	6*6*5	2.0	SW1,SW7
11	0800022	Switch	KFC6*6*6 horizontal	5.0	SW2~SW6
12	1000458	PCB	CGVG029 REV;B2.1 2005-05-18 control PCB	1.0	
13	1100002	Ferrite Core	outside22.5mm,inside13.8mm,high6.4mm	1.0	
14	1260002	Jumper	pin distance 5mm	1.0	JMP2
15	1260003	Jumper	pin distance 6mm	2.0	JMP3,JMP1
16	1310482	Conn Wafer	2.54 single 6P*550mm,red white conn wir e2~3 across	1.0	CON1
17	1500003	Receiver	PIC-317LM	1.0	
18	5440091	Cushion	8x7x6mm(double has sticker)rigidity 64	1.0	IR
19	5440119	Cushion	40x4x7mm(double has sticker)EVI tigheidity 64	1.0	

PARTSLIST

MIC PCB Assy Material List

Code: 5710067 (DG-K511S)

No	Part Code	Part Name	SPEC	QTY	Location
1	0000002	R Carbon Film	1/6W 1K ±5%	3.0	R18,R21,R26
2	0000004	R Carbon Film	1/6W 4.7K ±5%	1.0	R2
3	0000005	R Carbon Film	1/6W 10K ±5%	5.0	R5,R7,R10,R23,R29
4	0000013	R Carbon Film	1/6W 1.5K ±5%	1.0	R3
5	0000015	R Carbon Film	1/6W 15K ±5%	1.0	R17
6	0000017	R Carbon Film	1/6W 22K ±5%	2.0	R11,R12
7	0000018	R Carbon Film	1/6W 47K ±5%	2.0	R1,R24
8	0000020	R Carbon Film	1/6W 100K ±5%	4.0	R16,R20,R25,R27
9	0000061	R Carbon Film	1/6W 33E ±5%	1.0	R9
10	0000062	R Carbon Film	1/6W 6.8K ±5%	2.0	R4,R8
11	0000112	R Carbon Film	1/6W 2.7K ±5%	1.0	R6
12	0100007	Potentiometer	RD902N-BA1-B20K 3pin	1.0	VR2
13	0100011	Potentiometer	R0903NE-F20-C20K 3pin	1.0	VR1
14	0150001	C Cera	563 50V ±10%	2.0	C8,C9
15	0150007	C Cera	101 50V ±10%	4.0	C19,C24,C25,C27
16	0150008	C Cera	104 50V ±10% 5	6.0	C4,C5,C10,C23,C28,C29
17	0150013	C Cera	103 50V ±10%	1.0	C14
18	0150014	C Cera	222 50V ±10%	2.0	C6,C7
19	0150015	C Cera	223 50V ±10%	2.0	C12,C13
20	0190008	C Electro	50V 4.7UF ±20% D5	2.0	C30,C20
21	0190012	C Electro	50V 10UF ±20%	1.0	C17
22	0190031	C Electro	50V 3.3UF ±20%	3.0	C21,C26,C15
23	0190039	C Electro	25V 22UF ±20% D5	3.0	C3,C1,C18
24	0190041	C Electro	25V 220UF ±20% D8	1.0	C11
25	0190103	C Electro	16V 100UF ±20% D6*5	2.0	C2,C22
26	0250006	Coil	RH3.5*4.7*0.8	2.0	L1,L2
27	0330001	Zener Diode	5.6V 1/2W DO-35	1.0	D1
28	0450013	TR	C1815 β=70~700	1.0	Q1
29	0510058	IC	TP5299P	1.0	U1
30	0510129	IC	F4558N (DIP)	1.0	U2
31	1000305	PCB	KGVG005 REV:B1.1 Mic PCB 2004.11.19	1.0	
32	1100003	Ferrite Core	outside 16mm inside 12mm high 8mm	1.0	
33	1150166	Conn Wafer	silver 7pin Mic jack (short pin)	2.0	MIC1,MIC2
34	1260002	Jumper	pin distance 5mm	3.0	JMP1,JMP2,JMP4
35	1260020	Jumper	pin distance 4mm	1.0	JMP3
36	1310086	Conn Wire	2.54 double 4P/3P*350mm	1.0	CN1

PARTSLIST

Code: 5710070 (DG-K513S)

No	Part Code	Part Name	SPEC	QTY	Location
1	0000002	R Carbon Film	1/6W 1K ±5%	3.0	R18,R21,R26
2	0000004	R Carbon Film	1/6W 4.7K ±5%	1.0	R2
3	0000005	R Carbon Film	1/6W 10K ±5%	6.0	R7,R10,R23,R29,R5,R19
4	0000013	R Carbon Film	1/6W 1.5K ±5%	1.0	R3
5	0000015	R Carbon Film	1/6W 15K ±5%	1.0	R17
6	0000017	R Carbon Film	1/6W 22K ±5%	2.0	R11,R12
7	0000018	R Carbon Film	1/6W 47K ±5%	2.0	R1,R24
8	0000020	R Carbon Film	1/6W 100K ±5%	4.0	R16,R20,R27,R25
9	0000061	R Carbon Film	1/6W 33E ±5%	1.0	R9
10	0000062	R Carbon Film	1/6W 6.8K ±5%	2.0	R4,R8
11	0000112	R Carbon Film	1/6W 2.7K ±5%	1.0	R6
12	0150001	C Cera	563 50V ±10%	2.0	C8,C9
13	0150007	C Cera	101 50V ±10%	4.0	C19,C24,C25,C27
14	0150008	C Cera	104 50V ±10% 5	4.0	C4,C5,C10,C23
15	0150013	C Cera	103 50V ±10%	3.0	C14,C28,C29
16	0150014	C Cera	222 50V ±10%	2.0	C6,C7
17	0150015	C Cera	223 50V ±10%	2.0	C12,C13
18	0190008	C Electro	50V 4.7UF ±20% D5	2.0	C30,C20
19	0190012	C Electro	50V 10UF ±20%	2.0	C33,C17
20	0190030	C Electro	16V 100UF ±20% D5	2.0	C2,C22
21	0190031	C Electro	50V 3.3UF ±20%	3.0	C15,C21,C26
22	0190039	C Electro	25V 22UF ±20% D5	3.0	C3,C1,C18
23	0190041	C Electro	25V 220UF ±20% D8	1.0	C11
24	0250006	Coil	RH3.5*4.7*0.8	2.0	L1,L2
25	0330001	Zener Diode	5.6V 1/2W DO-35	1.0	D1
26	0450013	TR	C1815 β=70~700	1.0	Q1
27	0510058	IC	TP5299P	1.0	U1
28	0510129	IC	F4558N (DIP)	1.0	U2
29	1000459	PCB	KGVG007 REV:B1.2 MIC PCB	1.0	
30	1100003	Ferrite Core	outside 16mm inside 12mm high8mm	1.0	
31	1150004	Conn Wafer	XH-5Pin 2.54mm	1.0	CON2
32	1150166	Conn Wafer	silver 7pin (short pin)	2.0	MIC1,MIC2
33	1260002	Jumper	pin distance 5mm	1.0	JMP2
34	1260005	Jumper	pin distance 8mm	1.0	JMP1
35	1310267	Conn Wire	2.54 double 4P/3P*250mm	1.0	CN1

PARTSLIST

Code: 5710066 (DG-K516S)

No	Part Code	Part Name	SPEC	QTY	Location
1	0000002	R Carbon Film	1/6W 1K ±5%	3.0	R18,R21,R26
2	0000004	R Carbon Film	1/6W 4.7K ±5%	1.0	R2
3	0000005	R Carbon Film	1/6W 10K ±5%	5.0	R7,R10,R29,R23,R5
4	0000013	R Carbon Film	1/6W 1.5K ±5%	1.0	R3
5	0000015	R Carbon Film	1/6W 15K ±5%	1.0	R17
6	0000017	R Carbon Film	1/6W 22K ±5%	2.0	R11,R12
7	0000018	R Carbon Film	1/6W 47K ±5%	2.0	R1,R24
8	0000020	R Carbon Film	1/6W 100K ±5%	4.0	R16,R20,R25,R27
9	0000061	R Carbon Film	1/6W 33E ±5%	1.0	R9
10	0000062	R Carbon Film	1/6W 6.8K ±5%	2.0	R4,R8
11	0000112	R Carbon Film	1/6W 2.7K ±5%	1.0	R6
12	0100007	Potentiometer	RD902N-BA1-B20K 3pin	1.0	VR2
13	0100011	Potentiometer	R0903NE-F20-C20K 3pin	1.0	VR1
14	0150001	C Cera	563 50V ±10%	2.0	C8,C9
15	0150007	C Cera	101 50V ±10%	4.0	C19,C24,C25,C27
16	0150008	C Cera	104 50V ±10% 5	4.0	C4,C5,C10,C23
17	0150013	C Cera	103 50V ±10%	3.0	C14,C28,C29
18	0150014	C Cera	222 50V ±10%	2.0	C6,C7
19	0150015	C Cera	223 50V ±10%	2.0	C12,C13
20	0190008	C Electro	50V 4.7UF ±20% D5	2.0	C30,C20
21	0190012	C Electro	50V 10UF ±20%	1.0	C17
22	0190031	C Electro	50V 3.3UF ±20%	3.0	C15,C21,C26
23	0190039	C Electro	25V 22UF ±20% D5	3.0	C3,C1,C18
24	0190041	C Electro	25V 220UF ±20% D8	1.0	C11
25	0190103	C Electro	16V 100UF ±20% D6*5	2.0	C2,C22
26	0250006	Coil	RH3.5*4.7*0.8	2.0	L1,L2
27	0330001	Zener Diode	5.6V 1/2W DO-35	1.0	D1
28	0450013	TR	C1815 β=70~700	1.0	Q1
29	0510058	IC	TP5299P	1.0	U1
30	0510129	IC	F4558N (DIP)	1.0	U2
31	1000296	PCB	KGVG004 REV:B2.0 mic pcb 2004.11.16	1.0	
32	1100003	Ferrite Core	outside 16mm inside 12mm high 8mm	1.0	
33	1150166	Conn Wafer	silver 7pin mic jack (short pin)	2.0	MIC1,MIC2
34	1260002	Jumper	pin distance 5mm	2.0	JMP1,JMP2
35	1260003	Jumper	pin distance 6mm	1.0	JMP4
36	1260020	Jumper	pin distance 4mm	1.0	JMP3
37	1310086	Conn Wire	2.54 double 4P/3P*350mm	1.0	CN1

YUV PCB Assy Material List

Code: 5760021

No	Part Code	Part Name	SPEC	QTY	Location
1	0190025	C Electro	10V 470UF \pm 20% D8	3.0	C1.C2.C3
2	1000301	PCB	OGVG004 REV:B1.1 YUV PCB	1.0	
3	1150161	Conn Wafer	3pin AV3-8.4-10D-F pin :3.6MM	1.0	RCA1
4	1310273	Conn Wire	2.0double 6P*60mm,red white conn wire with 3P	1.0	CN1