

NOTES:

1. UNLESS OTHERWISE SPECIFIED.
 - A. ALL RESISTORS ARE EXPRESSED IN OHMS AND ARE 1/4 W 5%.
 - B. ALL CAPACITORS ARE EXPRESSED IN MICROFARADS.
 - C. ALL DIODES ARE IN4148.
 - D. ALL POLARIZED CAPS AND C3 ARE LOW ESR, LOW LEAKAGE, RADIAL CAPACITORS.
2. SWITCH SHOW IN "OUT" POSITION.
3. * INDICATES HEATSINK ON DEVICE. (Q1 AND Q2)
4. ▲ SEE SELECTION PROCEDURE.

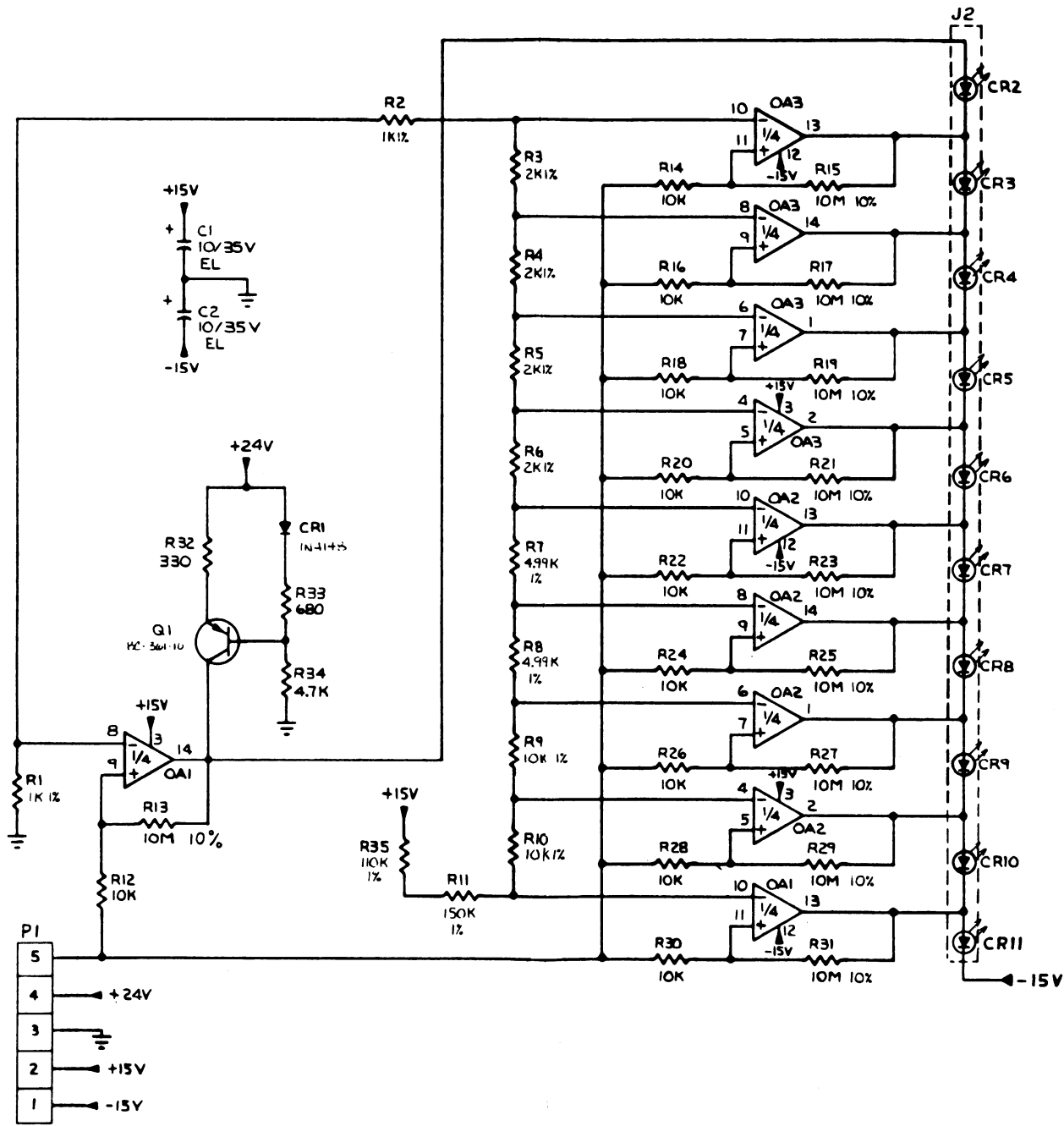

NOTES:

1. UNLESS OTHERWISE SPECIFIED.
 - A. ALL RESISTORS ARE EXPRESSED IN OHMS AND ARE 1/4 W 5%.
 - B. ALL CAPACITORS ARE EXPRESSED IN MICROFARADS.
 - C. ALL LED'S ARE RED.
 - D. ALL OP AMPS ARE LM339.
2. ALL LED CONNECTIONS MADE THROUGH J2.