

JACK BOARD

Professional Products 8760 South Sandy Parkway Sandy, Utah 84070		
Title: DDP JACK BOARD - 80-5359		
Size: B	Document Number: 055359B0.001	Rev: B0
Date: Thursday, March 30, 2000 Sheet 1 of 6		

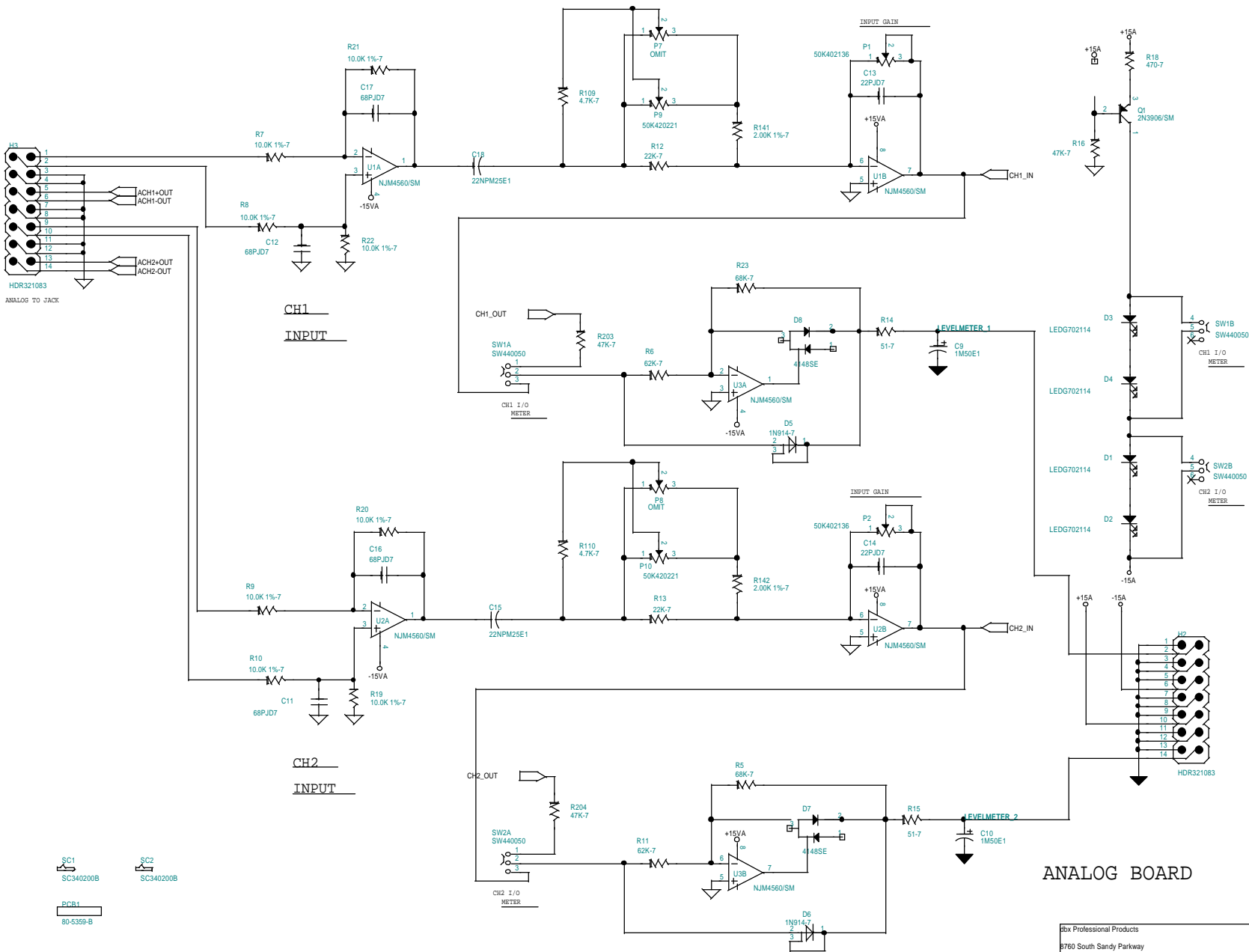

ANALOG BOARD

Pbx Professional Products 8760 South Sandy Parkway Sandy, Utah 84070		
Title: DIGITAL COMPRESSOR - 80-5359		
Size: B	Document Number: 055359B0.002	Rev: B0
Date: Thursday, March 30, 2000 Sheet 2 of 6		

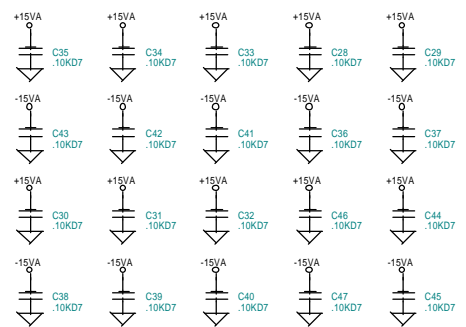
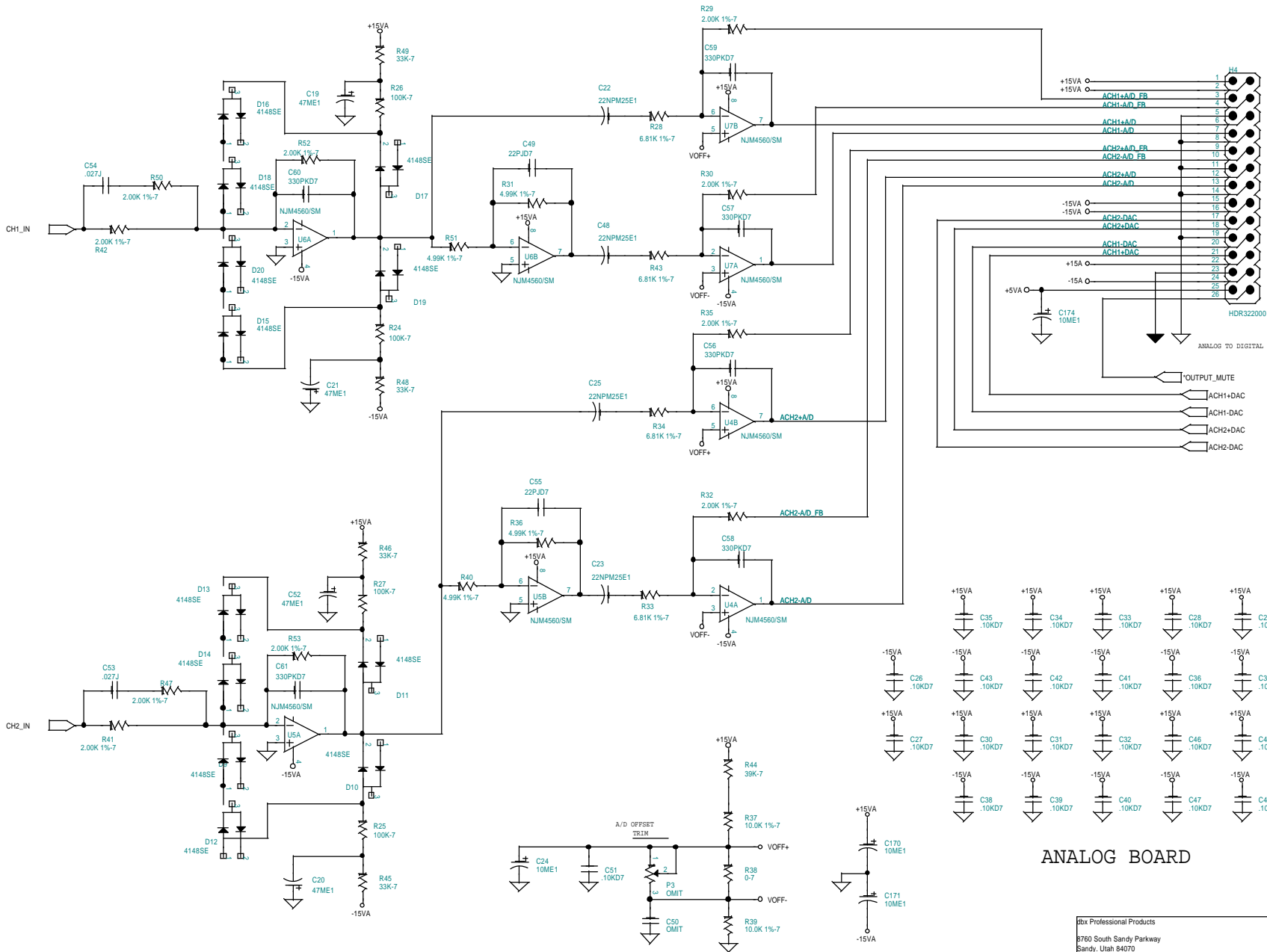

ANALOG BOARD

Professional Products 8760 South Sandy Parkway Sandy, Utah 84070		
Title: A/D - 80-5359		
Size: B	Document Number: 055359B0.003	Rev: B0
Date: Thursday, March 30, 2000 Sheet 3 of 6		

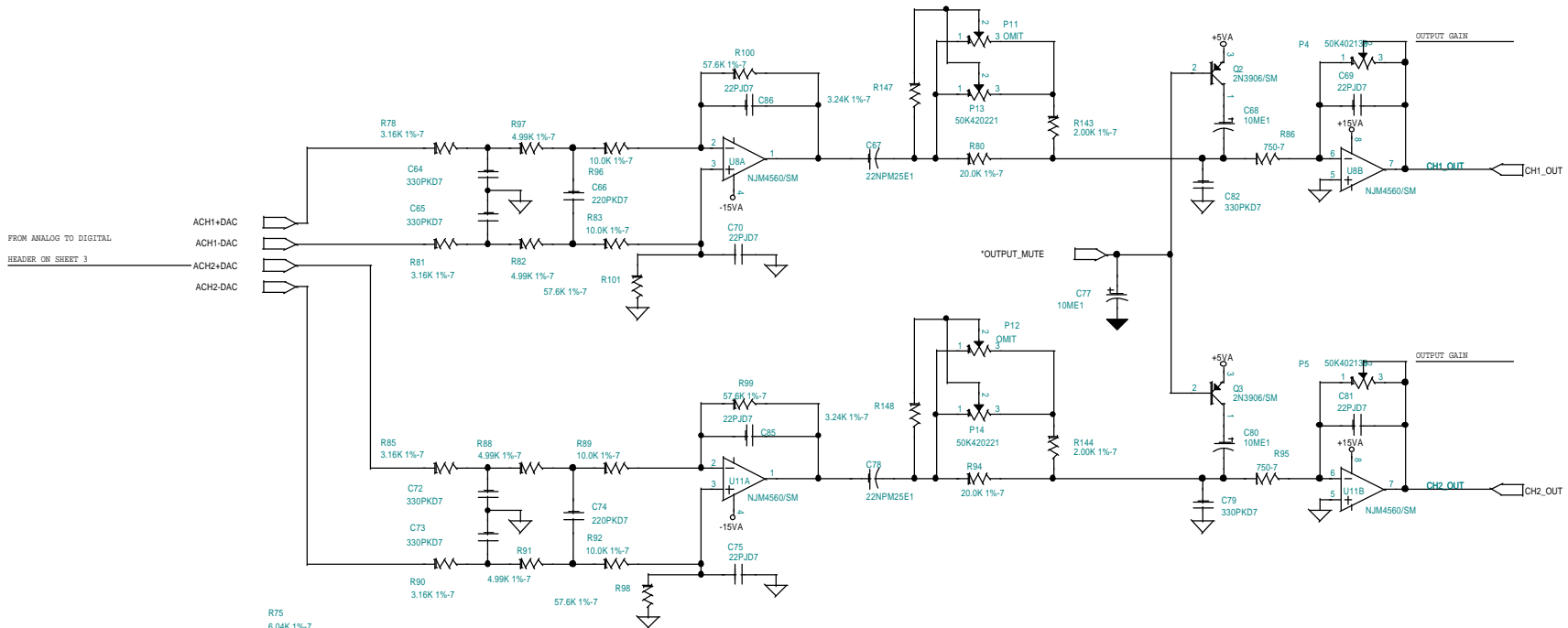

FROM ANALOG TO DIGITAL
HEADER ON SHEET 3

ACH1+DAC
ACH1-DAC
ACH2+DAC
ACH2-DAC

OUTPUT_GAIN

CH1_OUT

CH2_OUT

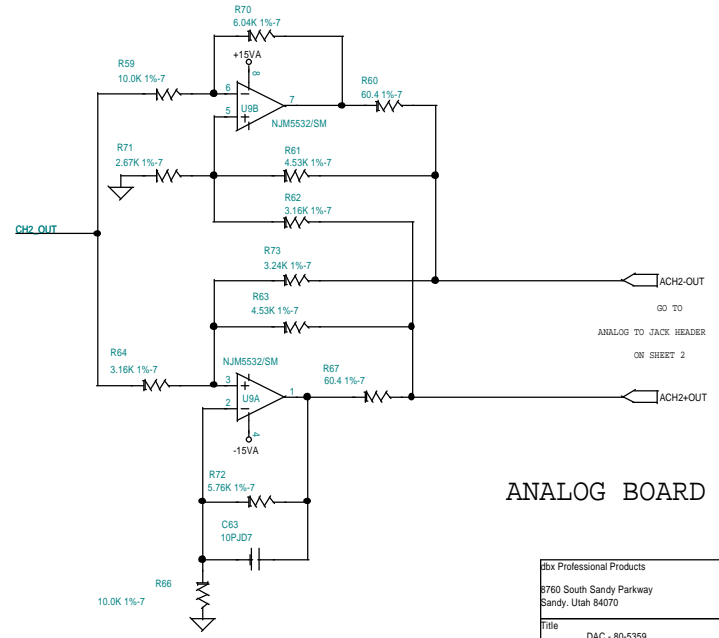
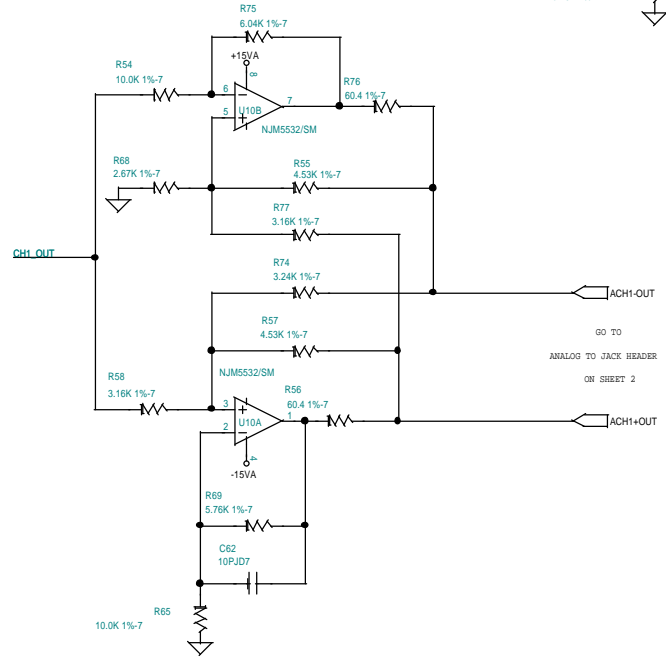

ANALOG BOARD

pbx Professional Products 8760 South Sandy Parkway Sandy, Utah 84070		
Title: DAC - 80-6359		
Size: B	Document Number: 055359B0.004	Rev: B0
Date: Thursday, March 30, 2000 Sheet 4 of 6		

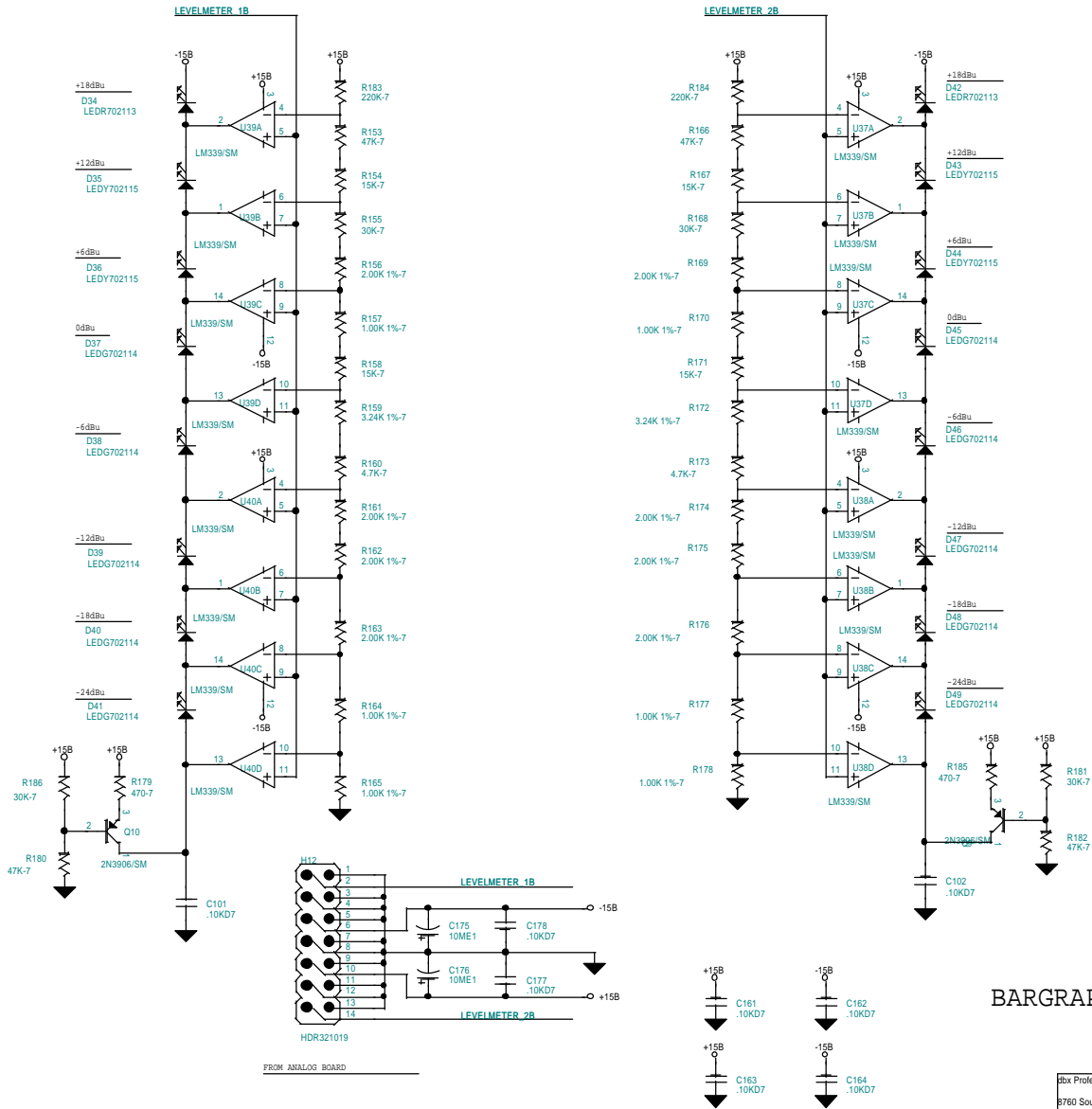

BARGRAPH BOARD

Pbx Professional Products 8760 South Sandy Parkway Sandy, Utah 84070		
Title: DDP - BARGRAPH PCB		
Size: B	Document Number: 05535980.005	Rev: B0
Date: Thursday, March 30, 2000 Sheet: 5 of 6		

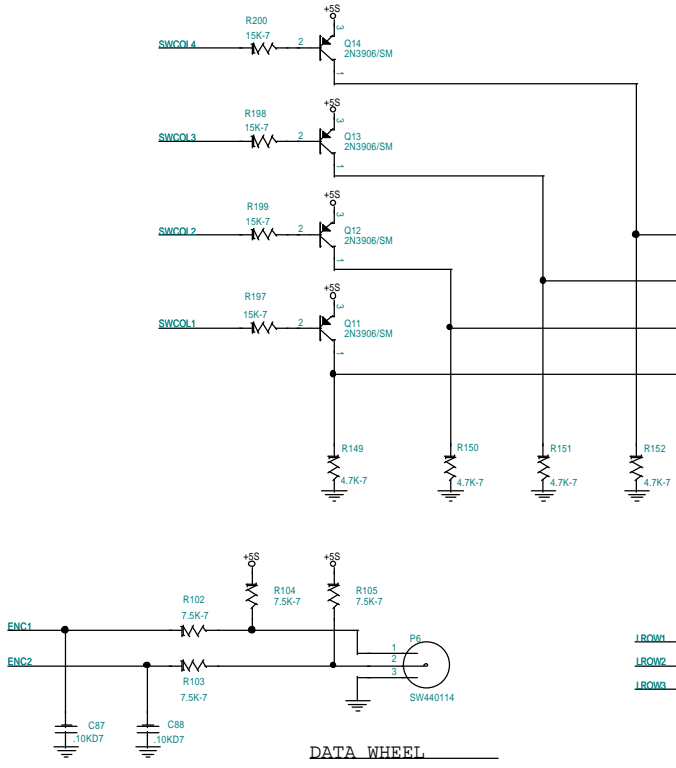
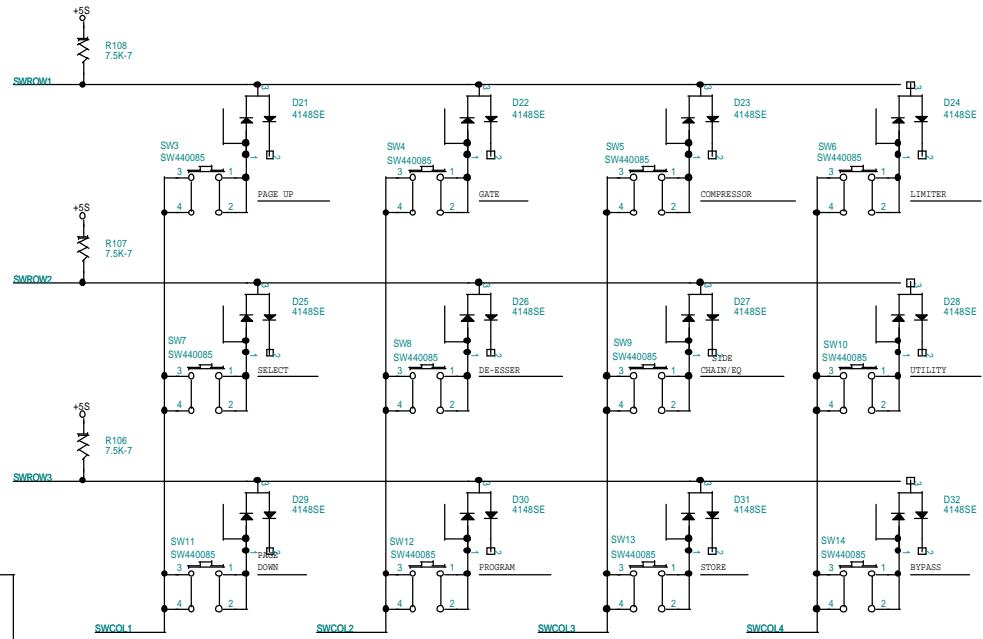
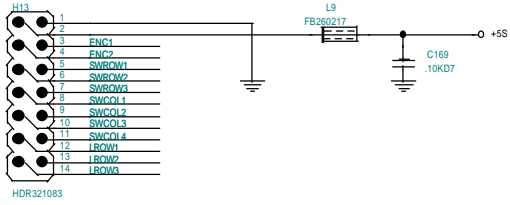

SWITCH BOARD

Pbx Professional Products 8760 South Sandy Parkway Sandy, Utah 84070		
Title DDP - SWITCH BOARD 80-5359		
Size B	Document Number 05535980.006	Rev B0
Date: Thursday, March 30, 2000 Sheet 6 of 6		

6	C1,C2,C3,C4,C66,C74	220PKD7	62-3138	220	pF Cap	50V 10%	Cerm, SMT 0805
4	C5,C6,C7,C8	470PKD7	62-3133	470	pF Cap	50V 10%	Cerm, SMT 0805
2	C9,C10	1M50E1	60-0044-01	1.0	uF Cap	50V -20/+20%	Elect., T&R C&F
4	C11,C12,C16,C17	68PJD7	62-3137	68	pF Cap	50V 5%	Cerm, SMT 0805
10	C13,C14,C49,C55,C69,C70, C75,C81,C85,C86	22PJD7	62-3134	22	pF Cap	50V 5%	Cerm, SMT 0805
8	C15,C18,C22,C23,C25,C48, C67,C78	22NPM25E1	60-0402	22	uF Cap	25V -20/+20%	Elect. NP , T&R
4	C19,C20,C21,C52	47ME1	60-0054-01	47	uF Cap	16V -20/+20%	Elect., T&R, 5X8mm body
9	C24,C68,C77,C80,C170, C171,C174,C175,C176	10ME1	60-0049-01	10	uF Cap	16V -20/+20%	Elect., -D Ammo
34	C26,C27,C28,C29,C30,C31, C32,C33,C34,C35,C36,C37, C38,C39,C40,C41,C42,C43, C44,C45,C46,C47,C51,C87, C88,C101,C102,C161,C162, C163,C164,C169,C177,C178	.10KD7	62-3139	.10	uF Cap	50V 20%	Cerm, SMT 0805
2	C53,C54	.027J	56-0033	.027	uF Cap	50V 5% Poly Film	273J ammo
12	C56,C57,C58,C59,C60,C61, C64,C65,C72,C73,C79,C82	330PKD7	62-3131	330	pF Cap	50V 10%	Cerm, SMT 0805
2	C62,C63	10PJD7	62-3140	10	pF Cap	50V 5%	Cerm, SMT 0805
14	D1,D2,D3,D4,D37,D38,D39, D40,D41,D45,D46,D47,D48, D49	LEDG702114	70-2114		Green Light Emitting Diode,		T1 (AUTO INSERT)
2	D5,D6	1N914-7	70-0110	1N914	Diode Silicon Switching,		75 Volts PIV, SMT
26	D7,D8,D9,D10,D11,D12,D13, D14,D15,D16,D17,D18,D19, D20,D21,D22,D23,D24,D25, D26,D27,D28,D29,D30,D31, D32	4148SE	70-0113	4148SE	Diode, SMT		
2	D34,D42	LED702113	70-2113		Red Light Emitting Diode, T1		(AUTO INSERT)
4	D35,D36,D43,D44	LEDY702115	70-2115		Yellow Light Emitting Diode, T1		(AUTO INSERT)
4	D50,D51,D57,D58	LSY702137	70-2137		LED, YELLOW, SMT		
2	D52,D53	LSR702135	70-2135		LED, RED, SMT		
6	D54,D55,D56,D59,D60,D61	LSG702136	70-2136		LED, GREEN, SMT		
4	H1,H2,H3,H13	HDR321083	32-1083		14 Pin Hdr, 7x2, 0.1" spacing,		0.025 pins, .375
1	H4	HDR322000	32-2000		26 Pin Hdr, 13x2, 0.1" spacing,		0.025 pins
1	H12	HDR321019	32-1019		14 Pin Hdr, 2x7 Rt Angle, .1" spc,		.025"gold Plt Pins
2	J1,J3	J320206	32-0206		XLR Female, R/A PC Mount Latching		A Series
4	J2,J4,J5,J7	J320119	32-0119		1/4 Phone Jack, Hor. Mount, Full		Nose Thread Slimline
2	J6,J8	J320204	32-0204		XLR Male, R/A PC Mount A Series		
5	L1,L2,L3,L4,L9	FB260217	26-0217		Ferrite Bead, 2.5Kohms @70Mhz,		SMT 0805
4	P1,P2,P4,P5	50K402136	40-2136		50 K "A" 16mm, Rot Pot, 15mm		D shaft, 41 Click
6	P3,P7,P8,P11,P12,C50	OMIT	00-0000		This part has been omitted		
1	P6	SW440114	44-0114		Encoder, 24 Pos. Vert Mount		15mm Shaft
4	P9,P10,P13,P14	50K420221	42-0221		50 K Trim Pot, Vertical Mount,		AMMO
1	PCB1	80-5359-B	80-5359-B		DBX DDP ANALOG BOARD, RAW		
9	Q1,Q2,Q3,Q9,Q10,Q11,Q12, Q13,Q14	2N3906/SM	70-1059		2N3906 PNP, Transistor, SOT23		
10	R1,R2,R3,R4,R73,R74,R147, R148,R159,R172	3.24K 1%-7	52-4509	3.24	KOhm Resistor 1% 1/10 Watt		TF, SMT 0805
2	R5,R23	68K-7	50-1536	68	KOhm Resistor 5% 1/10 Watt		TF, SMT 0805

Bill Of Materials	September 25, 1998	9:51:03				
Quan Reference	Part	SYMAN	Description			
2	R6,R11	62K-7	50-1501	62	KOhm Resistor	5% 1/10 Watt TF, SMT 0805
18	R7,R8,R9,R10,R19,R20,R21, R22,R37,R39,R54,R59,R65, R66,R83,R89,R92,R96	10.0K 1%-7	52-4500	10.0	KOhm Resistor	1% 1/10 Watt TF, SMT 0805
2	R12,R13	22K-7	50-1522	22	KOhm Resistor	5% 1/10 Watt TF, SMT 0805
2	R14,R15	51-7	50-1524	51	Ohm Resistor	5% 1/10 Watt TF, SMT 0805
7	R16,R153,R166,R180,R182, R203,R204	47K-7	50-1502	47	KOhm Resistor	5% 1/10 Watt TF, SMT 0805
5	R17,R155,R168,R181,R186	30K-7	50-1538	30	KOhm Resistor	5% 1/10 Watt TF, SMT 0805
3	R18,R179,R185	470-7	50-1518	470	Ohm Resistor	5% 1/10 Watt TF, SMT 0805
4	R24,R25,R26,R27	100K-7	50-1504	100	KOhm Resistor	5% 1/10 Watt TF, SMT 0805
4	R28,R33,R34,R43	6.81K 1%-7	52-4515	6.81	KOhm Resistor	1% 1/10 Watt TF, SMT 0805
22	R29,R30,R32,R35,R41,R42, R47,R50,R52,R53,R141, R142,R143,R144,R156,R161, R162,R163,R169,R174,R175, R176	2.00K 1%-7	52-4506	2.00	KOhm Resistor	1% 1/10 Watt TF, SMT 0805
8	R31,R36,R40,R51,R82,R88, R91,R97	4.99K 1%-7	52-4511	4.99	KOhm Resistor	1% 1/10 Watt TF, SMT 0805
1	R38	0-7	50-1531	0	Ohm Resistor	5% 1/10 Watt TF, SMT 0805
1	R44	39K-7	50-1528	39	KOhm Resistor	5% 1/10 Watt TF, SMT 0805
4	R45,R46,R48,R49	33K-7	50-1512	33	KOhm Resistor	5% 1/10 Watt TF, SMT 0805
4	R55,R57,R61,R63	4.53K 1%-7	52-4510	4.53	KOhm Resistor	1% 1/10 Watt TF, SMT 0805
4	R56,R60,R67,R76	60.4 1%-7	52-4503	60.4	Ohm Resistor	1% 1/10 Watt TF, SMT 0805
8	R58,R62,R64,R77,R78,R81, R85,R90	3.16K 1%-7	52-4508	3.16	KOhm Resistor	1% 1/10 Watt TF, SMT 0805
2	R68,R71	2.67K 1%-7	52-4507	2.67	KOhm Resistor	1% 1/10 Watt TF, SMT 0805
2	R69,R72	5.76K 1%-7	52-4512	5.76	KOhm Resistor	1% 1/10 Watt TF, SMT 0805
2	R70,R75	6.04K 1%-7	52-4513	6.04	KOhm Resistor	1% 1/10 Watt TF, SMT 0805
2	R80,R94	20.0K 1%-7	52-4501	20.0	KOhm Resistor	1% 1/10 Watt TF, SMT 0805
2	R86,R95	750-7	50-1530	750	Ohm Resistor	5% 1/10 Watt TF, SMT 0805
4	R98,R99,R100,R101	57.6K 1%-7	52-4514	57.6	KOhm Resistor	1% 1/10 Watt TF, SMT 0805
7	R102,R103,R104,R105,R106, R107,R108	7.5K-7	50-1521	7.5	KOhm Resistor	5% 1/10 Watt TF, SMT 0805
8	R109,R110,R149,R150,R151, R152,R160,R173	4.7K-7	50-1509	4.7	KOhm Resistor	5% 1/10 Watt TF, SMT 0805
8	R154,R158,R167,R171,R197, R198,R199,R200	15K-7	50-1516	15	KOhm Resistor	5% 1/10 Watt TF, SMT 0805
6	R157,R164,R165,R170,R177, R178	1.00K 1%-7	52-4505	1.00	KOhm Resistor	1% 1/10 Watt TF, SMT 0805
2	R183,R184	220K-7	50-1514	220	KOhm Resistor	5% 1/10 Watt TF, SMT 0805
10	R187,R188,R189,R190,R191, R192,R193,R194,R195,R196	100-7	50-1515	100	Ohm Resistor	5% 1/10 Watt TF, SMT 0805
2	R201,R202	680-7	50-1511	680	Ohm Resistor	5% 1/10 Watt TF, SMT 0805
2	SC1,SC2	SC340200B	34-0200-B	Switch Cap, Lighted, blank, dbx		
2	SW1,SW2	SW440050	44-0050	Mini In/Out DPDT Switch (6 Pin) E-Switch		
12	SW3,SW4,SW5,SW6,SW7,SW8, SW9,SW10,SW11,SW12,SW13, SW14	SW440085	44-0085	Lite Touch Switch, Mini, w/Projected Plunger		
9	U1,U2,U3,U4,U5,U6,U7,U8, U11	NJM4560/SM	72-4233	NJM4560 Dual Op-Amp, SMT SOIC		
2	U9,U10	NJM5532/SM	72-1439	IC, 5532MD, DUAL BIPOLAR OPAMP, SMT-SO8.2		

DOD Software
DDP ANALOG BOARD 80-5359
055359B0.000

Revised: September 23, 1998
Revision: B0

Page

Bill Of Materials September 25, 1998 9:51:03
Quan Reference Part SYMAN Description

055359b0

4 U37,U38,U39,U40
4 WA1,WA2,WA3,WA4

LM339/SM 72-4034
WA280187 28-0187-A

LM339 Low Power, Low offset voltage Quad Comparator
Washer, for grounding J320119

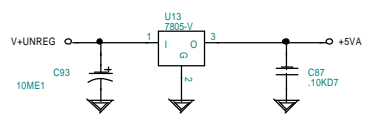
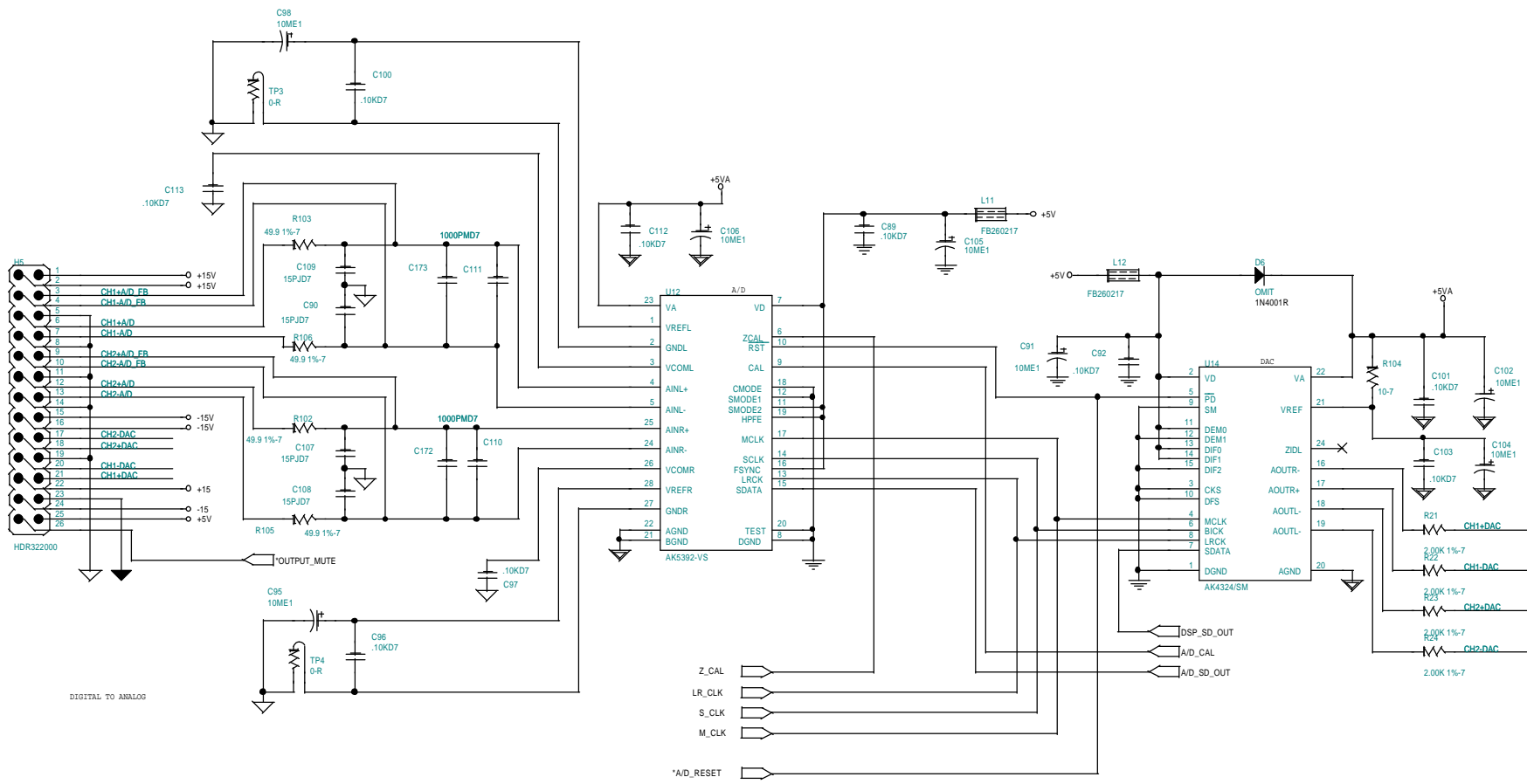

DIGITAL BOARD

DDP Professional Products 8760 South Sandy Parkway Sandy, Utah 84070		
Title: DDP DIGITAL A/D - 80-5328		
Size: B	Document Number: 055375C2.001	Rev: C2
Date: Thursday, March 23, 2000	Sheet: 1 of 5	

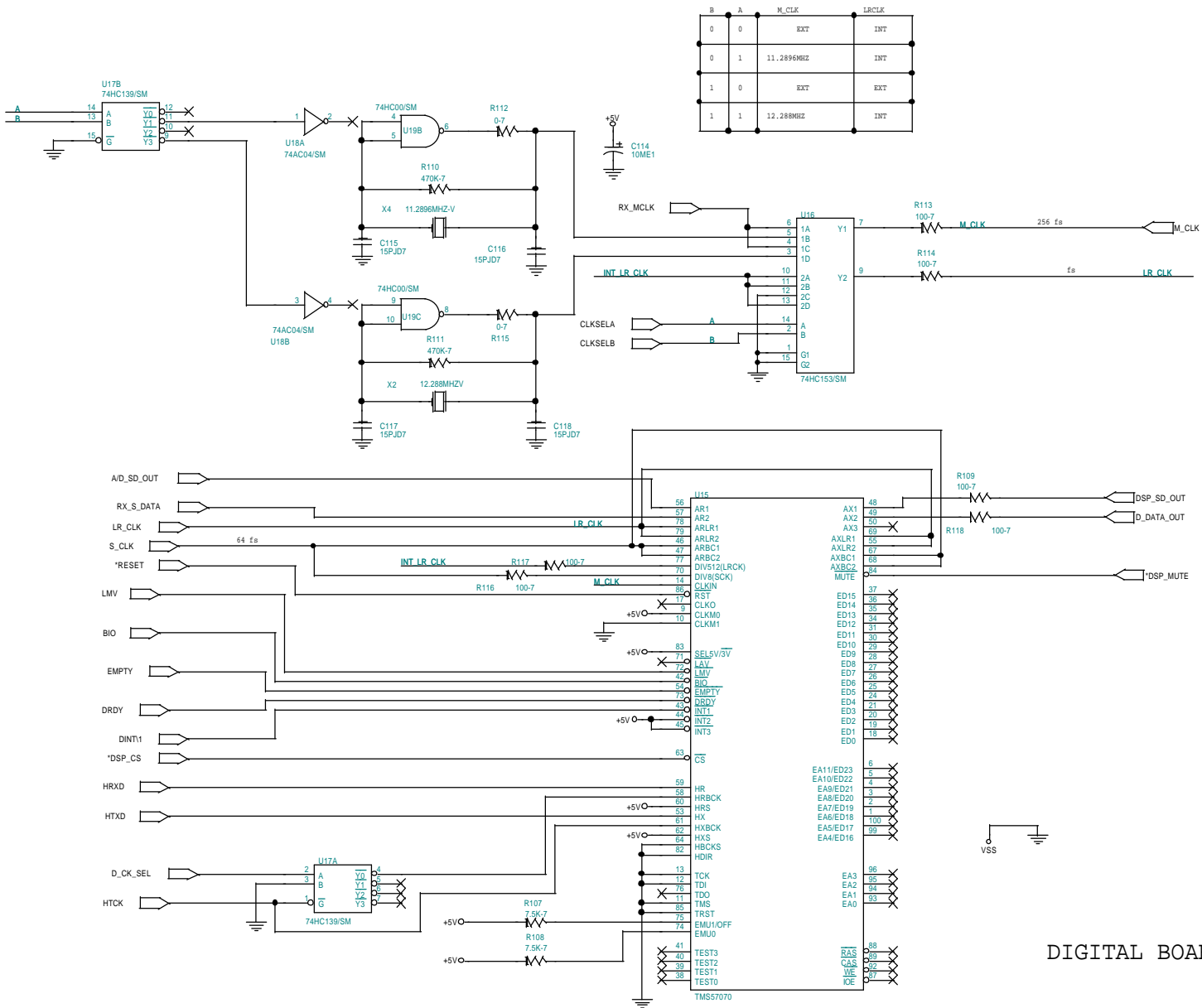

DIGITAL BOARD

dx Professional Products 8760 South Sandy Parkway Sandy, Utah 84070		
Title: DDP DIGITAL DSP - 80-5328		
Size: B	Document Number: 055375C2.002	Rev: C2
Date: Thursday, March 23, 2000 Sheet 2 of 5		

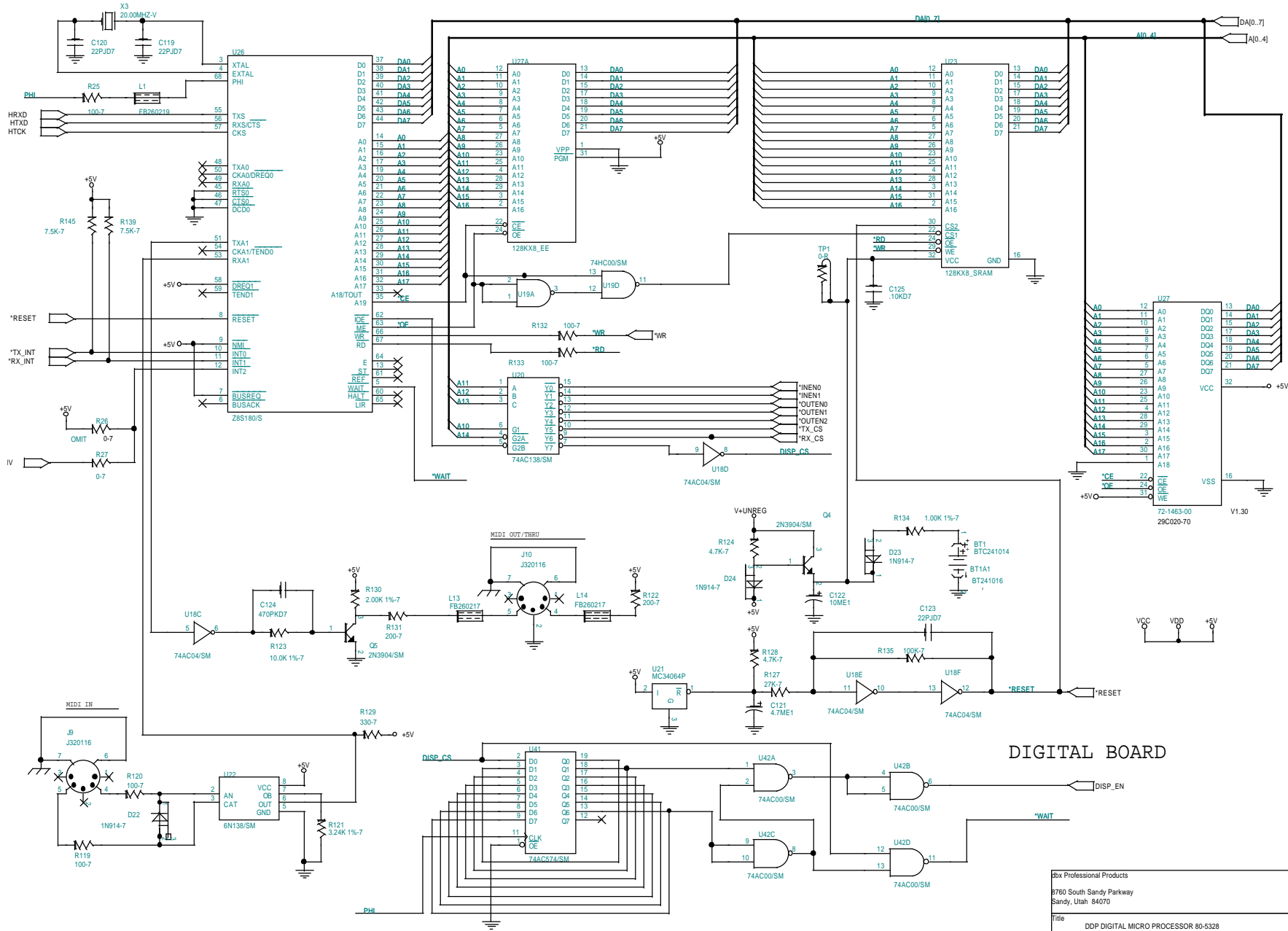

DIGITAL BOARD

Pbx Professional Products		
8760 South Sandy Parkway Sandy, Utah 84070		
Title DDP DIGITAL MICRO PROCESSOR 80-5328		
Size B	Document Number 055375C2.003	Rev C2
Date: Thursday, March 23, 2000 Sheet 3 of 5		

SWITCH BOARD

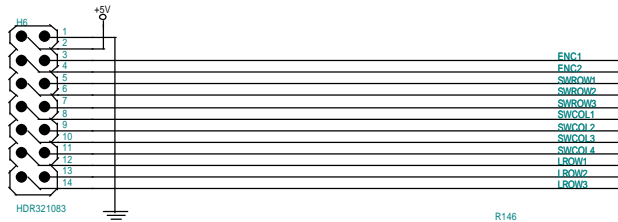

DIGITAL I/O

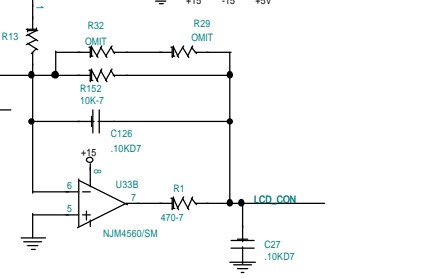
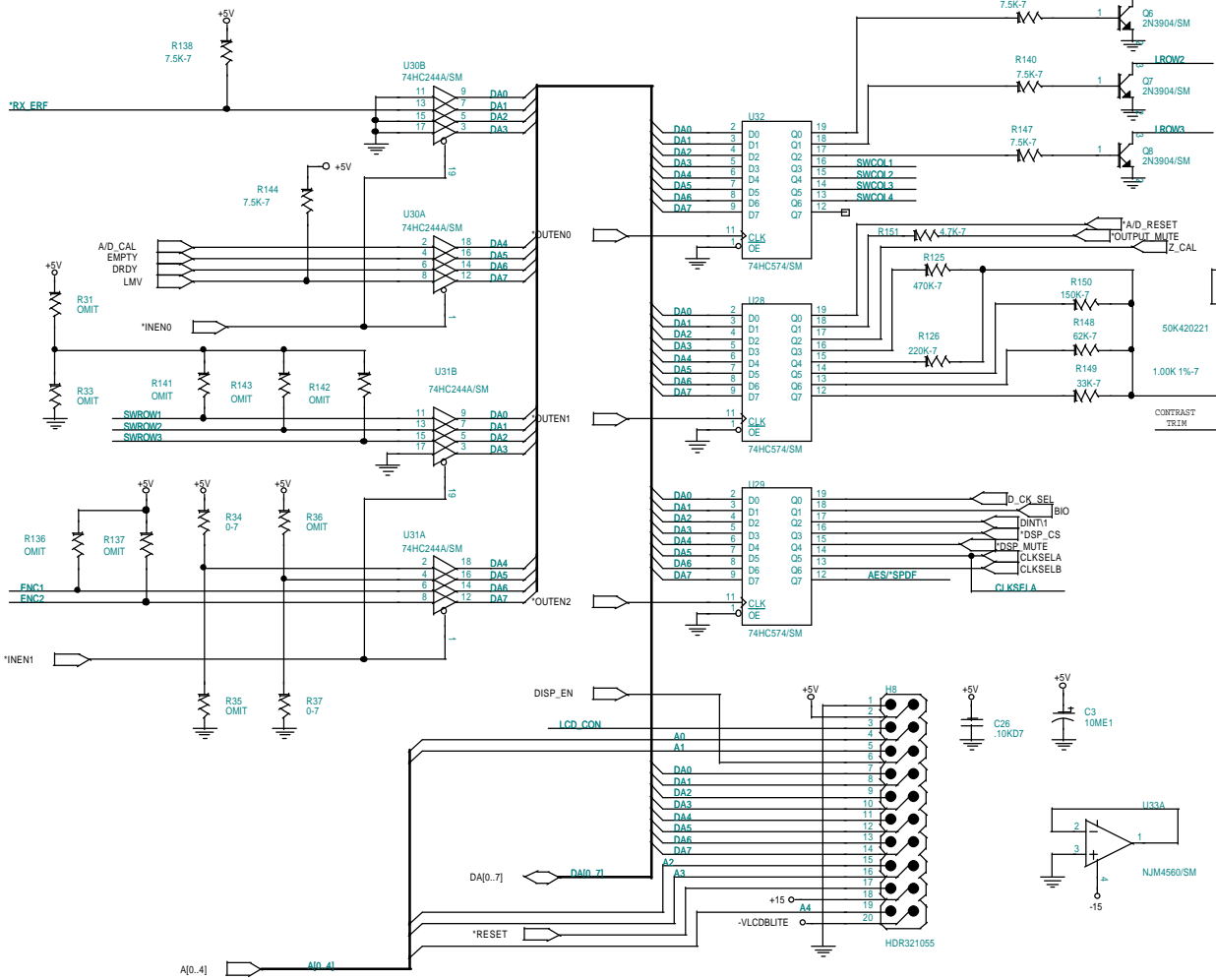
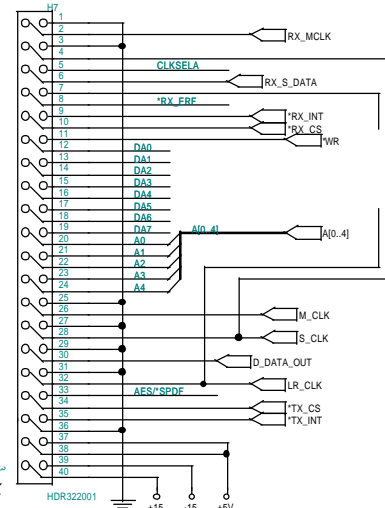

DIGITAL BOARD

LCD

dbx Professional Products		
8760 South Sandy Parkway Sandy, Utah 84070		
Title: dbx DDP DIGITAL I/O 80-5328		
Size: B	Document Number: 055375C2.004	Rev: C2
Date: Thursday, March 23, 2000	Sheet: 4 of 5	

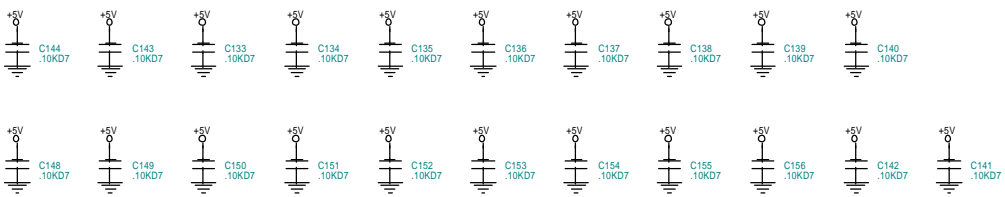
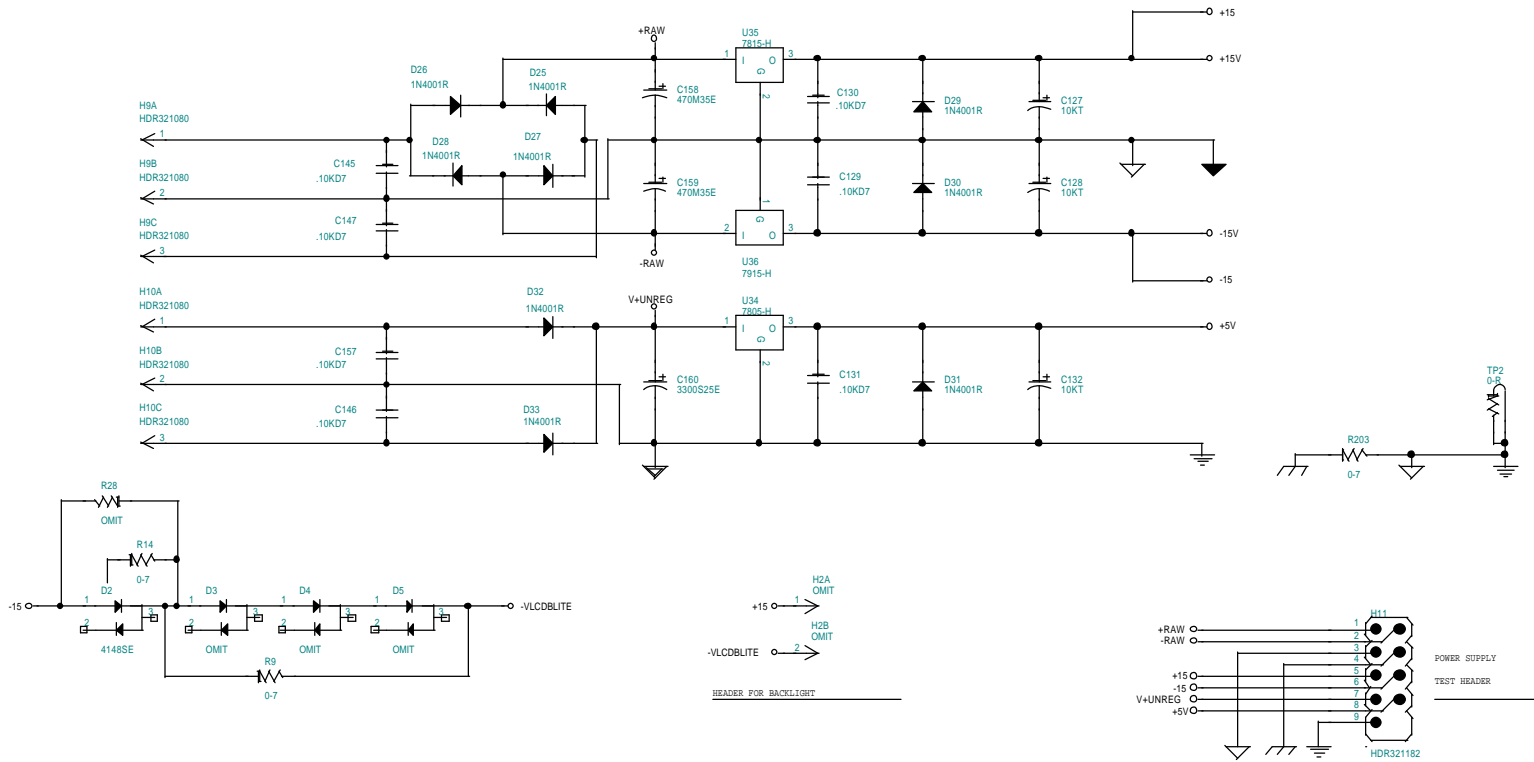

PCB1
80-5328-C

HS1
HST704204

HS2
INST704209

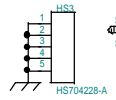

SR3
SR280058

SR4
SR280058

SR1
SR280059

SR2
SR280059

DIGITAL BOARD

dbx Professional Products 8760 South Sandy Parkway Sandy, Utah 84070		
Title dbx DDP DIGITAL POWER SUPPLY - 80-5328		
Size B	Document Number 055375C2.005	Rev C2
Date: Thursday, March 23, 2000	Sheet 5	of 5

&l0 (s0P (s15H (s8V (s0S &l6D &l66P &l3E &a7L &a120M &l61FDOD Software

Page 1

dbx DDP DIGITAL BOARD 80-5328

Revised: December 16, 1998

055375C2.000

Revision: C2

Bill Of Materials

December 17, 1998

8:15:00

Quan Reference

Part

SYMAN

Description

Quan	Reference	Part	SYMAN	Description
1	BT1	BTC241014	24-1014	Holder For 3V Battery
1	BT1A1	BT241016	24-1016	3V Battery, Lithium, Eveready Part #CR2032
11	C3,C91,C93,C95,C98,C102,C104,C105,C106,C114,C122	10ME1	60-0049-01	10 uF Cap 16V -20/+20% Elect., -D Ammo
42	C26,C27,C87,C89,C92,C96,C97,C100,C101,C103,C112,C113,C125,C126,C129,C130,C131,C133,C134,C135,C136,C137,C138,C139,C140,C141,C142,C143,C144,C145,C146,C147,C148,C149,C150,C151,C152,C153,C154,C155,C156,C157	.10KD7	62-3139	.10 uF Cap 50V 20% Cerm, SMT 0805
8	C90,C107,C108,C109,C115,C116,C117,C118	15PJD7	62-3128	15 pF Cap 50V 5% Cerm, SMT 0805
4	C110,C111,C172,C173	1000PMD7	62-3136	1000 pF Cap 50V 20% Cerm, SMT 0805
3	C119,C120,C123	22PJD7	62-3134	22 pF Cap 50V 5% Cerm, SMT 0805
1	C121	4.7ME1	60-0048-01	4.7 uF Cap 16V -20/+20% Elect., T&R
1	C124	470PKD7	62-3133	470 pF Cap 50V 10% Cerm, SMT 0805
3	C127,C128,C132	10KT	62-0163	10 uF Cap 16V 10% Tantalum T&R
2	C158,C159	470M35E	60-0060	470 uF Cap 35V -20/+20% Elect-S
1	C160	3300S25E	60-0087	3300 uF Cap 25V -20/+80% Elect-L
1	D2	4148SE	70-0113	4148SE Diode, SMT
3	D22,D23,D24	1N914-7	70-0110	1N914 Diode Silicon Switching, 75 Volts PIV, SMT
9	D25,D26,D27,D28,D29,D30,D31,D32,D33	1N4001R	70-0000	1N4001 Silicon Rectifier, 1 Amp, 50 Volts PIV, RADIAL
19	H2,D3,D4,D5,D6,R26,U27A,R28,R29,R31,R32,R33,R35,R36,R136,R137,R141,R142,R143	OMIT	00-0000	This part has been omitted
1	H5	HDR322000	32-2000	26 Pin Hdr, 13x2, 0.1" spacing, 0.025 pins
1	H6	HDR321083	32-1083	14 Pin Hdr, 7x2, 0.1" spacing, 0.025 pins, .375
1	H7	HDR322001	32-2001	40 Pin hdr, 20x2 0.1" spacing
1	H8	HDR321055	32-1055	20 Pin Hdr, 10X2, 0.1" spacing, 0.025 pins
2	H9,H10	HDR321080	32-1080	3 Pin Header, 0.1" spacing, 0.025" sq pins, Locking
1	H11	HDR321182	32-1182	9 Pin Hdr, 5X2, Straight, .23", 0.1" spacing
1	HS1	HS704204	70-4204	Heatsink, 3 Regulator, Top
1	HS2	INS704209	70-4209	Insulator, 3 Regulator Heatsink
1	HS3	HS704228-A	70-4228-A	Heatsink Base, 3 reg
2	J9,J10	J320116	32-0116	JACK, Shielded 5 pin DIN, PCB mount
1	L1	FB260219	26-0219	Ferrite Bead, 600 ohms @100Mhz, SMT 0805
4	L11,L12,L13,L14	FB260217	26-0217	Ferrite Bead, 2.5Kohms @70Mhz, SMT 0805
2	MW1,MW2	MODWIRE	00-0000	Mod Wire
1	P1	50K420221	42-0221	50 K Trim Pot, Vertical Mount, AMMO
1	PCB1	80-5328-C	80-5328-C	DBX DDP DIGITAL BOARD WITH DIGITAL IO, RAW
5	Q4,Q5,Q6,Q7,Q8	2N3904/SM	70-1058	2N3904 NPN, Transistor, SOT23
1	R1	470-7	50-1518	470 Ohm Resistor 5% 1/10 Watt TF, SMT 0805
8	R9,R14,R27,R34,R37,R112,R115,R203	0-7	50-1531	0 Ohm Resistor 5% 1/10 Watt TF, SMT 0805
2	R13,R134	1.00K 1%-7	52-4505	1.00 KOhm Resistor 1% 1/10 Watt TF, SMT 0805
5	R21,R22,R23,R24,R130	2.00K 1%-7	52-4506	2.00 KOhm Resistor 1% 1/10 Watt TF, SMT 0805
11	R25,R109,R113,R114,R116,	100-7	50-1515	100 Ohm Resistor 5% 1/10 Watt TF, SMT 0805

DOD Software

dbx DDP DIGITAL BOARD 80-5328

Revised: December 16, 1998

055375C2.000

Revision: C2

Bill Of Materials

December 17, 1998

8:15:00

Quan Reference

Part

SYMAN

Description

Quan Reference	Part	SYMAN	Description
	R117,R118,R119,R120,R132, R133		
4	R102,R103,R105,R106	49.9 1%-7 52-4502	49.9 Ohm Resistor 1% 1/10 Watt TF, SMT 0805
1	R104	10-7 50-1500	10 Ohm Resistor 5% 1/10 Watt TF, SMT 0805
9	R107,R108,R138,R139,R140, R144,R145,R146,R147	7.5K-7 50-1521	7.5 KOhm Resistor 5% 1/10 Watt TF, SMT 0805
3	R110,R111,R125	470K-7 50-1523	470 KOhm Resistor 5% 1/10 Watt TF, SMT 0805
1	R121	3.24K 1%-7 52-4509	3.24 KOhm Resistor 1% 1/10 Watt TF, SMT 0805
2	R122,R131	200-7 50-1510	200 Ohm Resistor 5% 1/10 Watt TF, SMT 0805
1	R123	10.0K 1%-7 52-4500	10.0 KOhm Resistor 1% 1/10 Watt TF, SMT 0805
3	R124,R128,R151	4.7K-7 50-1509	4.7 KOhm Resistor 5% 1/10 Watt TF, SMT 0805
1	R126	220K-7 50-1514	220 KOhm Resistor 5% 1/10 Watt TF, SMT 0805
1	R127	27K-7 50-1527	27 KOhm Resistor 5% 1/10 Watt TF, SMT 0805
1	R129	330-7 50-1517	330 Ohm Resistor 5% 1/10 Watt TF, SMT 0805
1	R135	100K-7 50-1504	100 KOhm Resistor 5% 1/10 Watt TF, SMT 0805
1	R148	62K-7 50-1501	62 KOhm Resistor 5% 1/10 Watt TF, SMT 0805
1	R149	33K-7 50-1512	33 KOhm Resistor 5% 1/10 Watt TF, SMT 0805
1	R150	150K-7 50-1526	150 KOhm Resistor 5% 1/10 Watt TF, SMT 0805
1	R152	10K-7 50-1503	10 KOhm Resistor 5% 1/10 Watt TF, SMT 0805
1	S27	PLCC/R-32 70-3026	32 PLCC Socket Rectangle, surface mount
2	SR1,SR2	SR280059 28-0059	Screw, 6-32 x 1/4", Pozi, Pan, Black
2	SR3,SR4	SR280058 28-0058	Screw, 6-32 x 3/8", Pozi, Pan, Black
4	TP1,TP2,TP3,TP4	0-R 50-0317	0 Ohm Resistor 5% 1/4 Watt Carbon Film Radial T&R
1	U12	AK5392-VS 72-1464	AK5392-VS 24 Bit A/D Converter, SMT
1	U13	7805-V 70-4014	7805 +5 Volt 1 Amp Voltage Regulator TO-220 VERT
1	U14	AK4324/SM 72-1426	AK4324 24 Bit Stereo DAC, Surface Mount
1	U15	TMS57070 72-3042	TMS57070 in QFP100 SPECIAL FOOTPRINT, SMT
1	U16	74HC153/SM 72-1430	74HC153 Dual 4-Channel Multiplexer, SMT
1	U17	74HC139/SM 72-5420	Dual 2 Line to 4 Line Decoder/Demultiplexer, SMT
1	U18	74AC04/SM 72-5426	74AC04, Hex Inverter,SMT
1	U19	74HC00/SM 72-5418	Quadruple 2-Input Positive-Nand Gate, SMT
1	U20	74AC138/SM 72-1452	74AC138 3 Line to 8 Line Decoder/Demultiplexer, SMT
1	U21	MC34064P 70-5004	MC34064 Undervoltage Sensing Circuit
1	U22	6N138/SM 70-2146	6N138 Opto-Isolator, SMT
1	U23	128KX8_SRA 72-5417	128K X 8 RAM Static, SMT
1	U26	Z8S180/S 72-4161	CPU Z8S180 Microprocessor, 20MHz, SMT
1	U27	72-1463-00 72-1463-00	W29C020-70 256K X 8 CMOS EEPROM,V1.30 (dbx DDP), SMT
3	U28,U29,U32	74HC574/SM 72-1263	Octal D-Type Edge Triggered Flip-Flops, SMT
2	U30,U31	74HC244A/S 72-1111	Octal Buffer-Line Driver W/3-State Outputs, SMT
1	U33	NJM4560/SM 72-4233	NJM4560 Dual Op-Amp, SMT SOIC
1	U34	7805-H 70-4014	7805 +5 Volt 1 Amp Voltage Regulator TO-220 HORIZ
1	U35	7815-H 70-4123	7815 +15 Volt 1 A Voltage Regulator TO-220 HORIZ
1	U36	7915-H 70-4124	7915 -15 Volt 1 A Voltage Regulator TO-220 HORIZ
1	U41	74AC574/SM 72-1453	Octal D-Type Edge triggered Flip-Flops, SMT 74AC574
1	U42	74AC00/SM 72-1454	Quadruple 2-Input Positive-Nand Gate, SMT 74AC00
1	X2	12.288MHZV 76-0319	12.288 MHZ Crystal, VERT
1	X3	20.00MHZ-V 76-0321	20.00 MHZ Crystal, Vert
1	X4	11.2896MHZ 76-0318	11.2896MHZ Crystal, VERT