

[All rights reserved. This service data sheet is the copyright of WIRELESS & ELECTRICAL TRADER and may not be reproduced, in whole or in part, without permission.]

"TRADER" SERVICE SHEET
1225

L15, C22 (M.W.) and L16, C22 (L.W.). Coils **L12, L15** and **L13, L16** are mounted at opposite ends of a length of ferrite rod to form the M.W. and L.W. internal aerials. Provision is also made for the use of the F.M. aerial on the A.M. bands. Aerial circuit tuning by **C22**.

Section **b** of **V2 (Mullard ECH81)** operates as A.M. mixer, and section **a** as oscillator. Oscillator grid coils **L17 (S.W.), L18 (M.W.)** and **L19 (L.W.)** are tuned by **C27**. Parallel trimming by **C28 (S.W.), C29, C30 (M.W.)** and **C31, C32 (L.W.)**; series tracking by **C33 (S.W.), C34 (M.W.)** and **C35 (L.W.)**. Reaction coupling from oscillator anode via **L20, L21** and **L22**. Additional reaction coupling on S.W. across the common impedance of tracker **C33**.

V3 (Mullard EF89) is a variable-mu R.F. pentode operating as intermediate frequency amplifier with tuned transformer couplings **C40, L25, L26, C41** and **C49, L30, L31, C50**.

A.M. Intermediate frequency 460 kc/s

Diode section **c** of **V4 (Mullard EABC80)** functions as A.M. signal detector, and the audio frequency component in its rectified output is developed across **R18** and passed via **S22, C56**, bass control circuit **C57, R25**, volume control **R27** and **C60** to grid of triode section **d** of **V4**, which operates

as A.F. amplifier. Tone correction at low-level settings of the volume control by **R26, C58**. I.F. filtering by **C53, R21** and the capacitance of the leads to chassis.

MR1 (Westinghouse WX6) is fed from **V3** anode circuit via **C51**, and the resulting D.C. potential developed across its load resistor **R16** is fed back as bias to **V2b** and **V3** giving automatic gain control on the A.M. bands.

Provision is made for the connection of a gramophone pick-up, across the volume control circuit via **S23**, which closes in the gram position of the waveband control. Three pick-up sockets are provided, and together with **R23, R24** are intended for amplitude correction between 78 r.p.m. and L.P. operation when using a turn-over type pick-up, as in the radiogram version. When employing a single-speed pick-up, or one of the interchangeable plug-in type, the pick-up leads should be connected to the L.P. socket for either pick-up.

DECCA

A.M./F.M. T

EMPLYING an elliptical moving coil speaker for reproduction of the middle and lower register, and an electrostatic speaker for high note reproduction, the Decca 66 is a 5-valve (plus rectifier and tuning indicator) A.M./F.M. table receiver, designed to operate from A.C. mains of 100-125V and 200-250V, 50c/s.

Model RG100 is a 3-speed console auto-radiogram version of the 66, employing the same chassis.

Release date and original prices: Model 66, September 1955, £30 18s 1d; Model RG100, August 1955, £41 14s 8d. Purchase tax extra.

CIRCUIT DESCRIPTION

A.M. aerial input via coupling coils **L11 (S.W.), L12 (M.W.)** and **L13 (L.W.)** to single-tuned circuits **L14, C22 (S.W.),**

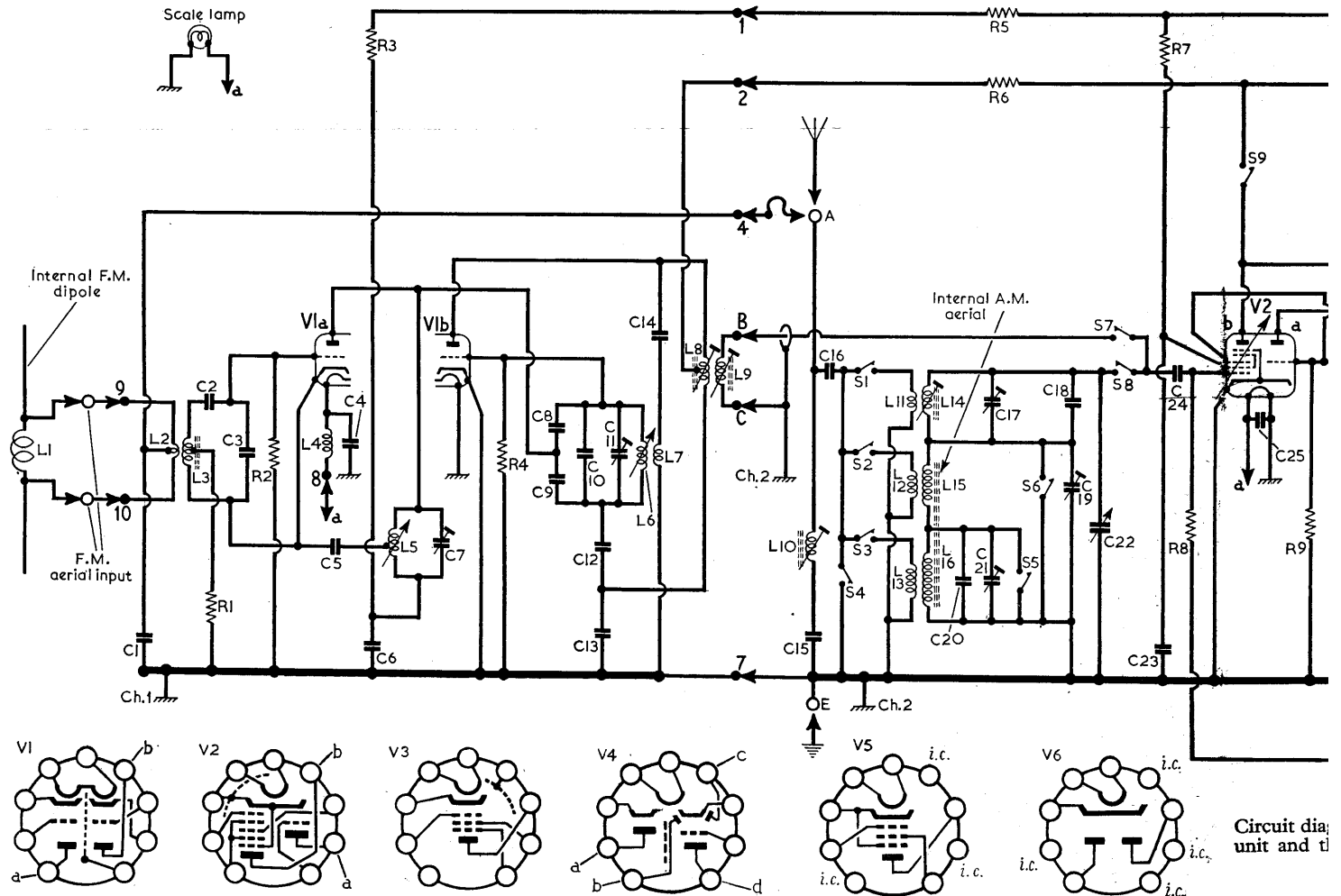

CCA 66 & RG100

F.M. Table Model and 3-speed Autoradiogram for A.C. Mains Operation

Resistance-capacitance coupling by **R29**, **C64** and **R31** between **V4d** and pentode output valve **V5** (Mullard EL84).

Treble-tone control by **R34** which shunts **C65** across **V5** control grid circuit and also controls the output of the electrostatic speaker. A polarizing voltage is fed to this speaker via **R44**. Negative feedback tone correction between **V5** anode and control grid circuit via **C67**, and by the frequency correction network **R40**, **C69**, **R41**, **R42**, **C70**, **R43**, **R38**, **R39**, **R37** and **C68** between **T1** secondary winding and **V4d** grid circuit. **S24** closes on M.W. and L.W. to increase the treble response on these bands.

H.T. current is supplied by I.H.C. full-wave rectifying valve **V6** (Mullard EZ80) H.T. Smoothing by **R30**, **R36**, **L32** and electrolytic capacitors **C62**, **C63**, **C72** and **C73**.

Operation on F.M.

Balanced 80Ω F.M. aerial input via coupling coil **L2** to fixed-tuned aerial circuit **L3**,

C2, **C3**. Section **a** of **V1** (Mullard ECC85) is an earthed-cathode R.F. amplifier. **V1a** anode/grid inter-electrode capacitance is neutralized by **C5**. The amplified output from **V1a** is coupled via single-tuned circuit **L5**, **C7** to **V1b**, which operates as an oscillator/mixer valve with tuned oscillator grid circuit **L6**, **C8**, **C9**, **C10**, **C11**. F.M. tuning is by means of the cores of **L5** and **L6** which are ganged to the common A.M./F.M. tuning control.

Oscillator radiation is kept to a minimum by means of **C8**, **C9**, **C12**, **C13** which form part of a balanced bridge circuit to prevent oscillator voltages from passing back into the R.F. amplifier.

V2b and **V3** form the two-valve F.M. intermediate frequency amplifier, which is coupled by tuned transformers **L8**, **L9**; **C38**, **L23**, **L24**, **C39**; and discriminator transformer **L27**, **L28**, **L29**, **C47**, to diode sections **a** and **b** of **V4**, which are connected in a ratio detector discriminator circuit.

F.M. intermediate frequency 10.7Mc/s.

The A.F. output of the ratio detector is developed across **C48**, and is passed via **S21** to the volume control circuit. Limiting is performed by the "fly-wheel" effect of D.C. reservoir **C55**. The limiting voltage developed across **C55** is fed back as an A.G.C. voltage to **V3** suppressor grid, but on S.W. **S20** closes to connect the suppressor grid to chassis.

GENERAL NOTES

Switches.—**S1-S24** are the waveband and radio/gram change-over switches ganged in four rotary units beneath the chassis. These units are indicated in the underside illustration of the chassis and shown in detail in the diagrams overleaf (cols. 5 and 6). The units are viewed here in the direction indicated by the arrows in location references E2 and E3. The associated switch table, in column 3 overleaf, indicates the switch operations in

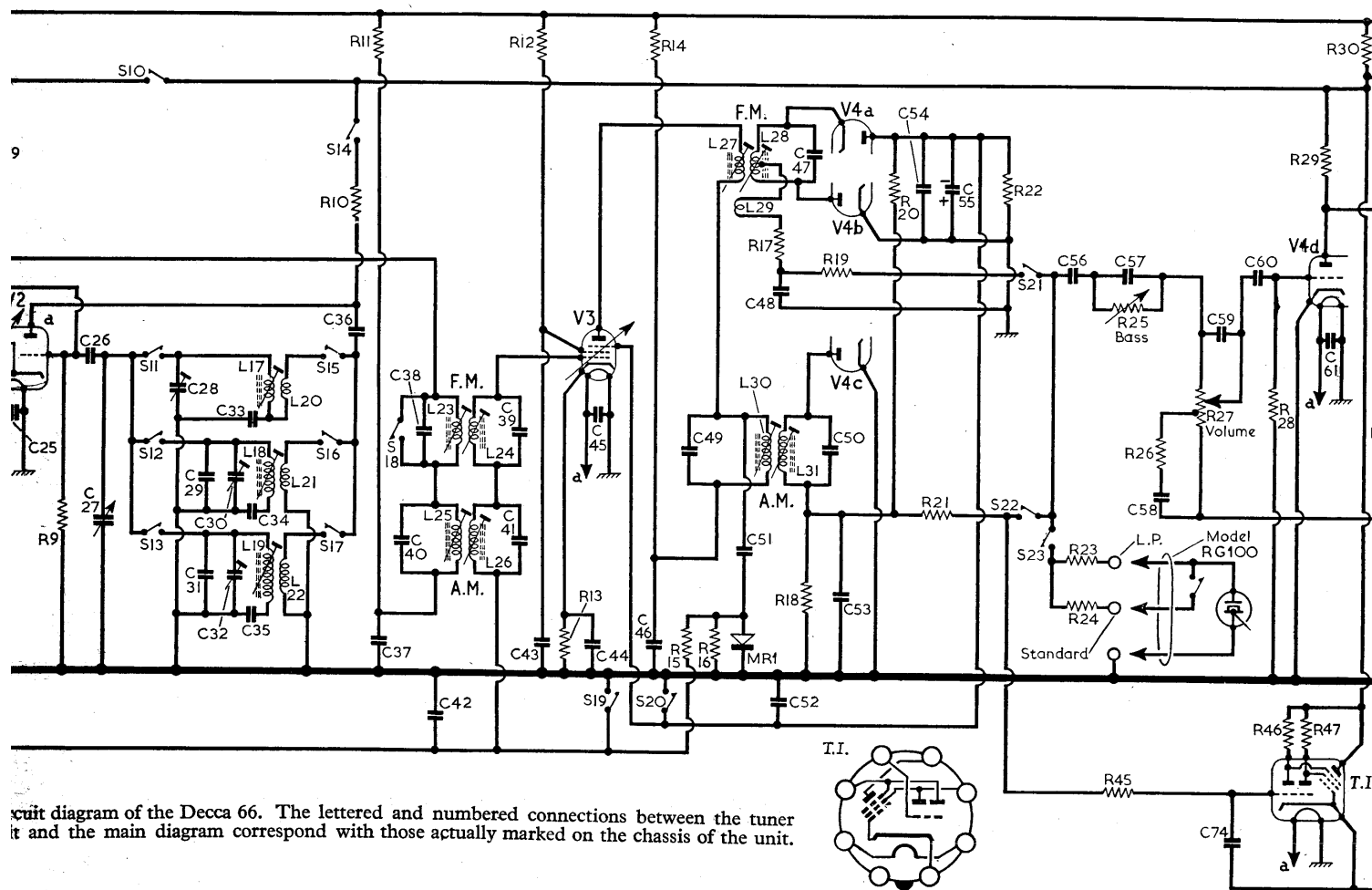

Circuit diagram of the Decca 66. The lettered and numbered connections between the tuner and the main diagram correspond with those actually marked on the chassis of the unit.

COMPONENT VALUES AND LOCATIONS

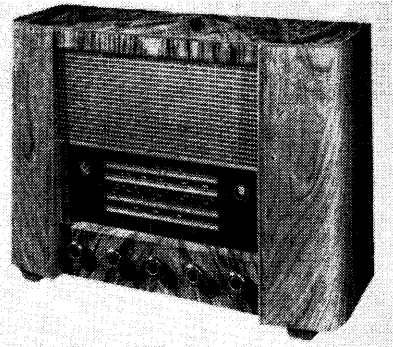

Appearance of the Decca 66.

the five control settings, starting from the fully anti-clockwise position of the control. A dash indicates open, and C, closed.

S25 is the Q.M.B. mains switch ganged with the volume control R27.

Scale Lamp.—This is a 6.5V, 0.3A lamp with a small clear spherical bulb and an M.E.S. base.

Model RG100.—This is an autoradio-gram version of the 66 employing an identical chassis, a Garrard RC111 three-

(Continued col. 1 overleaf)

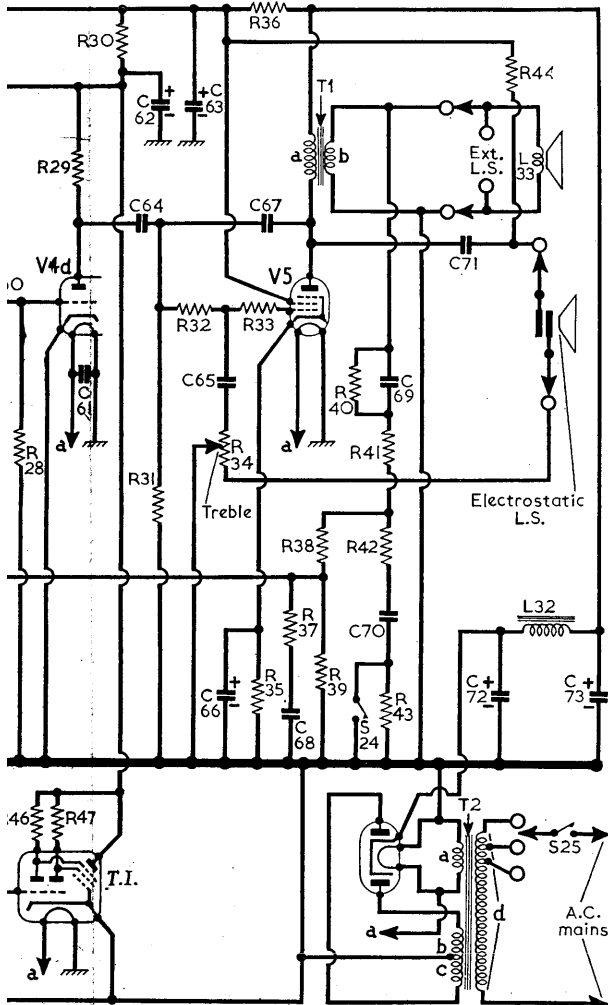

CAPACITORS		Values	Locations
C1	Aerial shunt ...	10pF	F4
C2	V1a C.G. ...	250pF	F4
C3	F.M. aerial tuning	10pF	F4
C4	Heater by-pass ...	250pF	F4
C5	Neut. coupling ...	8pF	F4
C6	H.T. decoupling ...	250pF	F4
C7	F.M. R.F. trim ...	10pF	F4
C8	F.M. tuning	7.5pF	F4
C9		7.5pF	F4
C10		3.8pF	F4
C11	6pF	F4	
C12	8pF	F4	
C13	105pF	F4	
C14	F.M. reaction coup.	30pF	F4
C15	I.F. filter tune ...	100pF	E2
C16	A.M. aerial coup. ...	200pF	E2
C17	S.W. aerial trim-	30pF	A1
C18	mers ...	5pF	A1
C19	M.W. aerial trim-	30pF	A1
C20	L.W. aerial trim-	100pF	B1
C21	mers ...	30pF	A1
C22	A.M. aerial tuning	—	A1
C23	V2b S.G. decoup. ...	0.005μF	E3
C24	V2b C.G. ...	50pF	E3
C25	Heater by-pass ...	0.005μF	E3
C26	V2a C.G. ...	50pF	E3
C27	A.M. osc. tuning ...	—	A1
C28	S.W. osc. trim. ...	30pF	E3
C29	M.W. osc. trimmers	30pF	E2
C30		30pF	E2
C31	L.W. osc. trimmers	185pF	E2
C32		30pF	E2
C33	S.W. osc. tracker ...	0.005μF	E3
C34	M.W. osc. tracker ...	565pF	E2
C35	L.W. osc. tracker ...	220pF	E2
C36	A.M. osc. coupling	300pF	E3
C37	H.T. decoupling	0.005μF	E3
C38	2nd F.M. I.F.T.	—	A1
C39	tuning ...	—	A1
C40	1st A.M. I.F.T.	—	A1
C41	tuning ...	—	A1
C42	A.M. A.G.C. decoup.	0.02μF	D3
C43	V3 S.G. decoupling	0.005μF	D3
C44	V3 cath. by-pass ...	0.005μF	D3
C45	Heater by-pass ...	0.005μF	D3
C46	H.T. decoupling ...	0.005μF	D3
C47	F.M. I.F.T. tun. ...	—	A1
C48	F.M. Load	300pF	D3
C49	2nd A.M. I.F.T.	—	A1
C50	tuning ...	—	A1
C51	A.M. A.G.C. coup.	50pF	D3
C52	F.M. A.G.C. decoup.	0.005μF	D3
C53	A.M. I.F. by-pass ...	100pF	D3
C54	F.M. I.F. by-pass ...	300pF	D3
C55	D.C. reservoir ...	2μF	D2
C56	A.F. coupling ...	0.01μF	D2
C57	Part bass control ...	300pF	C2
C58	Tone correctors	0.01μF	C2
C59		100pF	C2
C60	A.F. coupling ...	0.01μF	D3
C61	Heater by-pass ...	0.005μF	D3
C62	H.T. decoupling ...	8μF	A1
C63	A.F. coupling ...	32μF	D2
C64	Part treble control	0.01μF	D2
C65	V5 cath. by-pass ...	25μF	C2
C66	5pF	C2	
C67	0.1μF	C2	
C68	Neg. feed-back ...	0.05μF	C2
C69	0.25μF	C2	
C70	E.S. L.S. coupling	0.005μF	C2
C71	8μF	C3	
C72	H.T. smoothing ...	32μF	A1
C73	T.I. decoupling ...	0.01μF	B1

RESISTORS		Values	Locations
R1	V1a G.B. ...	20Ω	F4
R2	V1a C.G. ...	200kΩ	F4
R3	H.T. feed ...	1kΩ	F4
R4	V1b C.G. ...	300kΩ	F4
R5	H.T. feeds	10kΩ	E3
R6		10kΩ	E3
R7	V2b S.G. H.T. feed	39kΩ	E3
R8	V2b C.G. ...	1MΩ	E3
R9	V2a C.G. ...	20kΩ	E3
R10	H.T. feeds	27kΩ	E3
R11		1kΩ	D3
R12	V3 S.G. H.T. feed	100kΩ	D3
R13	V3 G.B. ...	330Ω	D3
R14	H.T. feed ...	1kΩ	D3
R15	A.M. A.G.C. decoup.	1MΩ	D3
R16	A.M. A.C.G. load ...	1.5MΩ	D3
R17	F.M. balancing ...	150Ω	D3
R18	A.M. signal load ...	220kΩ	D3
R19	Tone corrector ...	1MΩ	D2
R20	F.M. balancing ...	500kΩ	D3
R21	I.F. stopper ...	1MΩ	D2
R22	D.C. load ...	20kΩ	D2
R23	P.U. correctors	1.5MΩ	C3
R24		6.8MΩ	C3
R25	Bass control ...	5MΩ	C2
R26	Tone correction ...	51kΩ	C2
R27	Volume control ...	1.5MΩ	C2
R28	V4d C.G. ...	10MΩ	D3
R29	V4d anode load ...	220kΩ	D2
R30	H.T. smoothing ...	10kΩ	D2
R31	V5 C.G. ...	820kΩ	D2
R32	Part tone control ...	35kΩ	D2
L33	V5 C.G. stopper ...	2.2kΩ	C2
R34	Treble control ...	1MΩ	D2
R35	V5 G.B. ...	180Ω	C2
R36	H.T. smoothing ...	4.4kΩ	D3
R37	220Ω	C2	
R38	1kΩ	C2	
R39	1kΩ	C2	
R40	Negative feed-back	51kΩ	C2
R41	500Ω	C2	
R42	82Ω	C2	
R43	1kΩ	E2	
R44	E.S. L.S. polarizer	5.6kΩ	C2
R45	T.I. decoupling ...	820kΩ	D2
R46	T.I. loads ...	1MΩ	B1
R47		1MΩ	B1

OTHER COMPONENTS		Approx. Values (ohms)	Locations
L1	F.M. int. dipole ...	—	—
L2	F.M. aerial ...	—	F4
L3	Coup. coils ...	—	F4
L4	Heater choke ...	—	F4
L5	F.M. R.F. coil ...	—	F4
L6	F.M. Oscillator coils ...	—	F4
L7	coils ...	—	F4
L8	1st F.M. (Pri. I.F.T. {Sec. ...	—	F4
L9	I.F.T. {Sec. ...	—	F4
L10	A.M. I.F. filter ...	13.0	E2
L11	A.M. aerial coupling coils ...	15.0	A1
L12	15.0	B1	
L13	25.0	A1	
L14	A.M. aerial tuning coils ...	2.0	A1
L15	9.0	A1	
L16	—	E3	
L17	A.M. oscillator tuning coils ...	3.0	E2
L18	7.5	E2	
L19	29.0	E3	
L20	1.0	E2	
L21	2.0	E2	
L22	—	A1	
L23	2nd F.M. {Pri. ...	—	A1
L24	I.F.T. {Sec. ...	—	A1
L25	1st A.M. {Pri. ...	5.0	A1
L26	I.F.T. {Sec. ...	5.0	A1
L27	3rd F.M. {Pri. ...	3.0	A1
L28	I.F.T. {Sec. ...	—	A1
L29	Tert. ...	—	A1
L30	2nd A.M. {Pri. ...	5.0	A1
L31	I.F.T. {Sec. ...	5.0	A1
L32	H.T. smoothing ...	400.0	B1
L33	Speech coil ...	2.5	B1
T1	O.P. trans {a ...	400.0	C3
	b ...	—	
	c ...	—	
T2	Mains trans {a ...	280.0	B1
	b ...	280.0	B1
	c ...	30.0	D3
MR1	A.M. A.G.C. rect.	—	D3
S1-	Waveband switches	—	E2
S24	—	—	C2
S25	Mains sw., g'd R27	—	C2

Dealers are reminded that if the component numbers given in the accompanying tables are used when ordering replacement parts, it is advisable to mention the fact on the order, as these numbers may differ from those used in the manufacturers' circuit diagram.

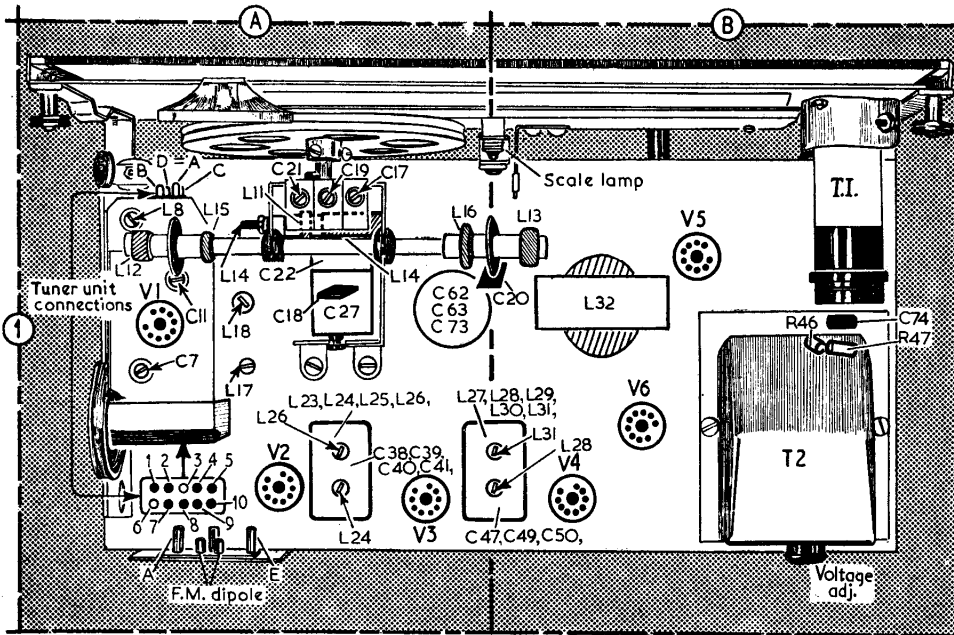

Plan illustration of the chassis. The F.M. tuner unit and its connections are identified in location reference A1.

General Notes—continued

speed record changer, and a Garrard GC2/PA turn-over crystal pick-up fitted with a Decca volume compensation switch (this latter feature must be mentioned when ordering a replacement pick-up head).

Modifications.—In the manufacturers' circuit diagram, C5 is shown as pre-set. The limiting capacitor C55 was 0.5 μ F in earlier models.

The colours of the leads from the electrostatic and moving coil speakers are black, red and yellow, blue respectively,

and similarly coloured connecting leads are employed between the chassis and the speaker tags. In our sample receiver, however, the chassis leads were not connected to speaker tags bearing similarly coloured leads. The black, red, yellow and blue chassis leads were connected in this case to speaker tags bearing blue, yellow, black and red leads, respectively.

Drive Cord Replacement.—About 36in and 50in of good-quality flax fishing line, plaited and waxed, are required for a new F.M. drive and gang drive respectively.

Switch Table

Switches	F.M.	S.W.	M.W.	L.W.	Gram.
S1	—	C	—	—	—
S2	—	—	—	—	—
S3	—	—	—	—	—
S4	C	—	—	C	—
S5	—	—	C	—	—
S6	—	C	—	—	—
S7	C	—	—	—	—
S8	—	C	—	C	—
S9	—	—	—	—	—
S10	C	—	—	—	—
S11	—	C	—	—	—
S12	—	—	C	—	—
S13	—	—	—	C	—
S14	—	C	—	C	—
S15	—	C	—	C	—
S16	—	—	C	—	—
S17	—	—	C	—	—
S18	—	C	—	C	—
S19	C	—	—	—	—
S20	—	C	—	—	—
S21	C	—	—	—	—
S22	—	C	—	C	—
S23	—	—	—	C	—
S24	—	—	C	—	—

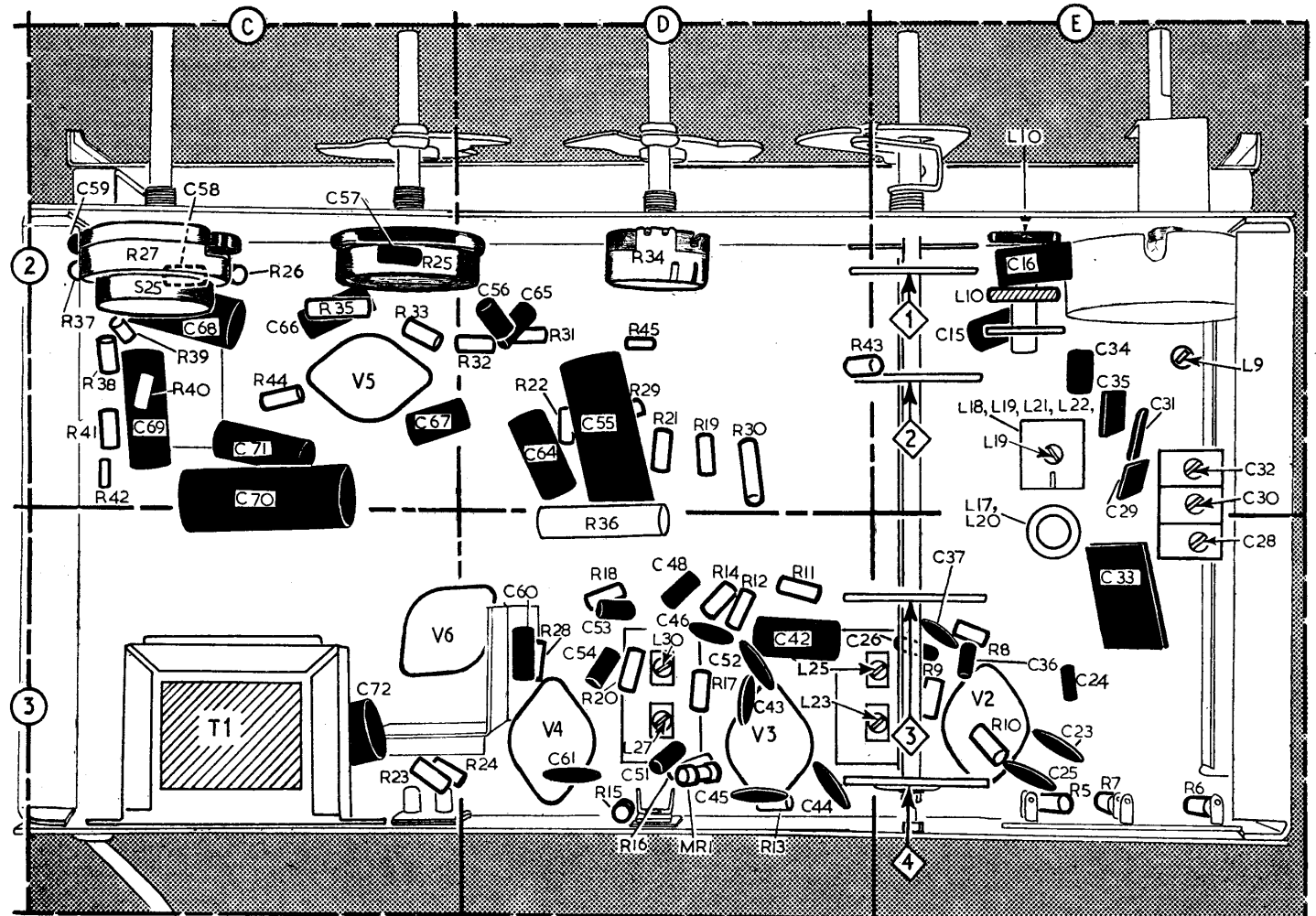

Underside view of main chassis. The switch units are identified by numbers 1-4 in diamonds, and are shown in detail in columns 5 and 6.

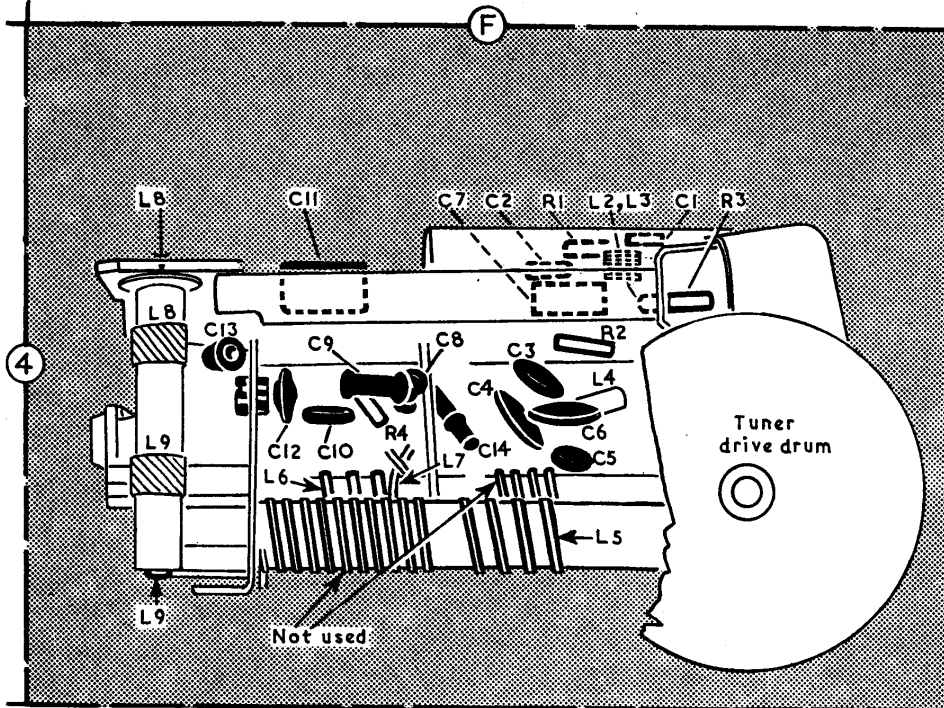

Side view of F.M. tuner unit chassis as seen with its screening cover removed.

of wobblator between chassis and junction of **S8**, **C24**, and make the following adjustments :

- 1.—Feed in a 10.7Mc/s signal, deviated by $\pm 60\text{kc/s}$, and adjust the cores of **L23** (location reference **E3**) and **L24** (**A1**) for maximum output.
- 2.—Adjust the cores of **L27** (**D3**) and **L28** (**A1**) for maximum output.
- 3.—Repeat the adjustments made in operations 1 and 2.
- 4.—Transfer wobblator output to F.M. aerial sockets. Feed in a 95Mc/s signal, deviated by $\pm 60\text{kc/s}$, and tune it in on receiver. Adjust the cores of **L8** (**A1**) and **L9** (**E2**) for maximum output.

F.M. R.F. and Oscillator Stages.

Check that with the gang at maximum capacitance, the cursor coincides with the datum line at the low-frequency end of the tuning scale. The tuner drive drive should now be fully clockwise.

- 5.—With wobblator and receiver tuned to 95Mc/s, adjust **C11** (**A1**) for maximum output.
- 6.—Adjust **C7** (**A1**) at the same frequency for maximum output. Disconnect wobblator output leads.

A.M. I.F. Stages.—Connect output of spot-frequency signal generator between chassis and junction of **S8**, **C24**. Switch receiver to M.W. and short-circuit **C27**. Make the following adjustments :

To make the gang drive drum accessible, the tuning scale should be removed (two spring clips) together with the scale backing plate (four self-tapping screws). Then turn gang to maximum capacitance and run the cords as shown in the sketch at the top of columns 8 and 9.

VALVE ANALYSIS

Valve voltages given in the table below are those derived from the manufacturers' information. The receiver was switched to M.W. and the gang turned to maximum capacitance, but there was no signal input. Voltages were measured with an Avometer Model 8, chassis being negative connection in every case.

Valve	Anode V	Screen V	Cath. V
V1 ECC85	—	—	—
V2 ECH81 {a	65	—	—
V2 ECH81 {b	212	55	—
V3 EF89	212	75	2
V4 EABC80 {a-c	—	—	—
V4 EABC80 {d	65	—	—
V5 EL84	310	215	7
V6 EZ80	330*	—	350†

* A.C. reading, each anode. † Cathode current, 59 mA.

CIRCUIT ALIGNMENT

Equipment Required.—A wobblated F.M. signal generator with an output impedance of 80Ω ; an output meter; an accurately calibrated spot-frequency signal generator; a 400Ω resistor; an insulated screwdriver-type trimming tool.

F.M. I.F. Stages.—Connect output meter across **T1** secondary winding. Switch receiver to F.M. Connect output

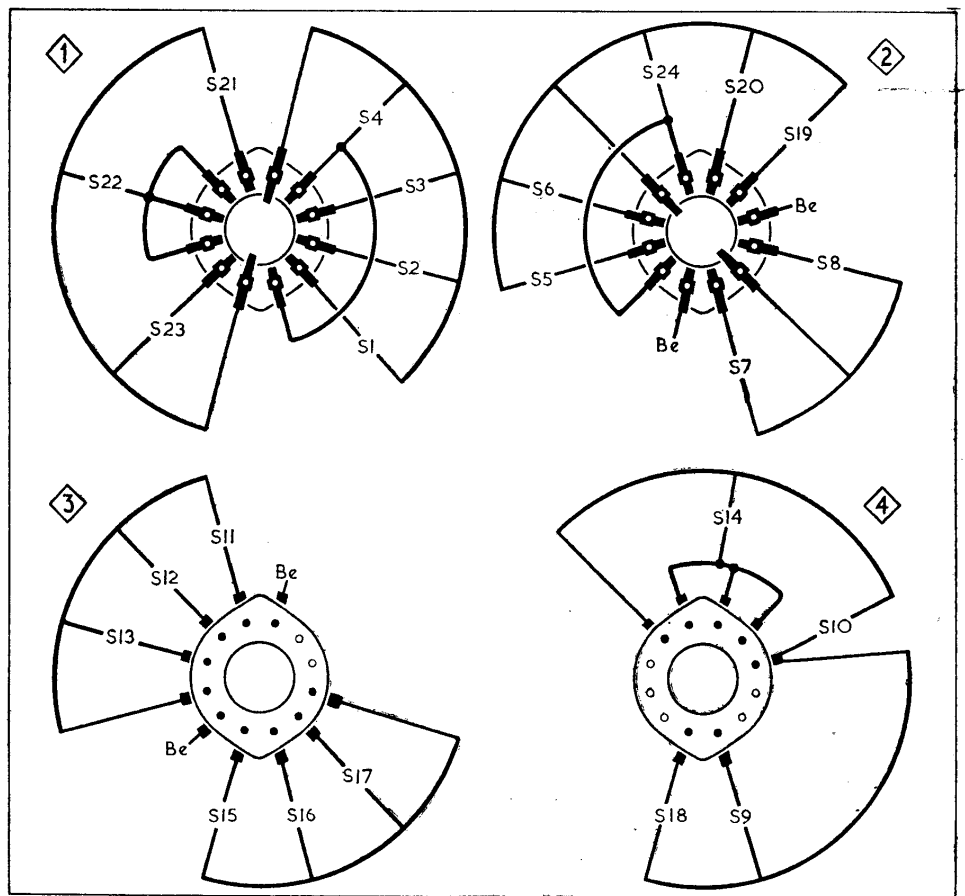
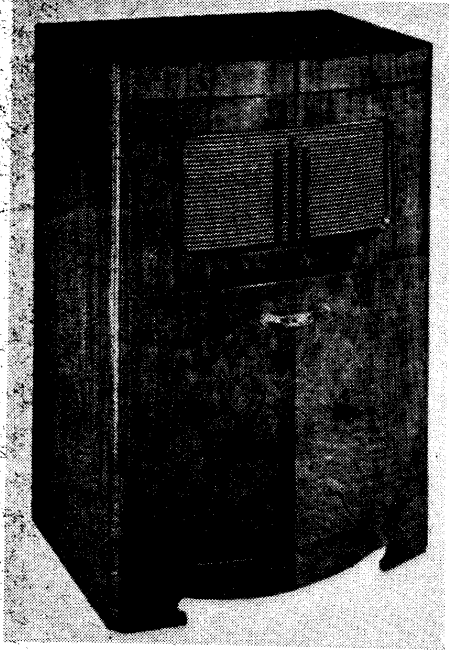
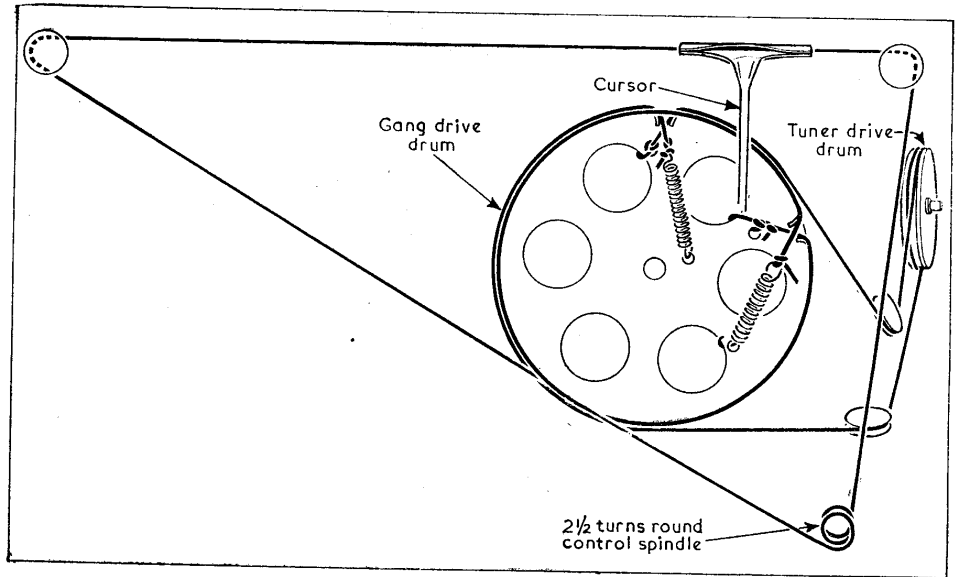

Diagram of the waveband switch units. They are identified by the numbers 1-4 in diamond surrounds in the underside illustration of the main chassis.



Appearance of the radiogram version RG100.



Sketch of the gang drive and F.M. unit drive cord systems as seen from the front of the chassis with the tuning scale and backing plate removed.

- 7.—Feed in 460kc/s signal and adjust the cores of **L25** (E3), **L26** (A1), **L30** (D3) and **L31** (A1) for maximum output.
- 8.—Repeat the adjustments in operation 7 until no further improvement results.
- 9.—Transfer signal generator leads, via a dummy aerial to A.M. aerial and earth sockets, and remove short-circuit from **C27**. At the same frequency, adjust the core of **L10** (E2) for minimum output.

A.M. R.F. and Oscillator Stages.—

Connect output of spot-frequency signal generator to A.M. aerial and earth sockets via a 400Ω resistor in the live lead for S.W. alignment, or via a dummy aerial for M.W. and L.W. alignment.

- 10.—Switch receiver to S.W. and tune it to 6Mc/s. Feed in a 6Mc/s signal and adjust the cores of **L17** (A1) and **L14** (A1) for maximum output, setting the core of **L17** to the peak further away from the adjusting end of the coil.
- 11.—Tune receiver to 18Mc/s, feed in an 18Mc/s signal and adjust **C28** (E3) and **C17** (A1) for maximum output, setting **C28** to the lesser capacitance peak.
- 12.—Repeat operations 10 and 11 until calibration is correct at both ends of band.
- 13.—Switch receiver to M.W. and tune it to 500m. Feed in a 600kc/s signal and adjust the core of **L18** (A1) for maximum output.
- 14.—Tune receiver to 250m, feed in a 1,200 kc/s signal and adjust **C30** (E2) and **C19** (A1) for maximum output.
- 15.—Repeat operations 13 and 14 until calibration is correct at both ends of band.
- 16.—Switch receiver to L.W. and tune it to 2,000m. Feed in a 150kc/s signal and adjust the core of **L19** (E2) for maximum output.
- 17.—Tune receiver to 1,200m, feed in a 250kc/s signal and adjust **C32** (E2) and **C21** (A1) for maximum output.

ADDITIONAL NOTES AND MODIFICATIONS