

DENON

Hi-Fi AV Surround Amplifier

SERVICE MANUAL

MODEL AVC-3020 2020/2020G

AV SURROUND AMPLIFIER

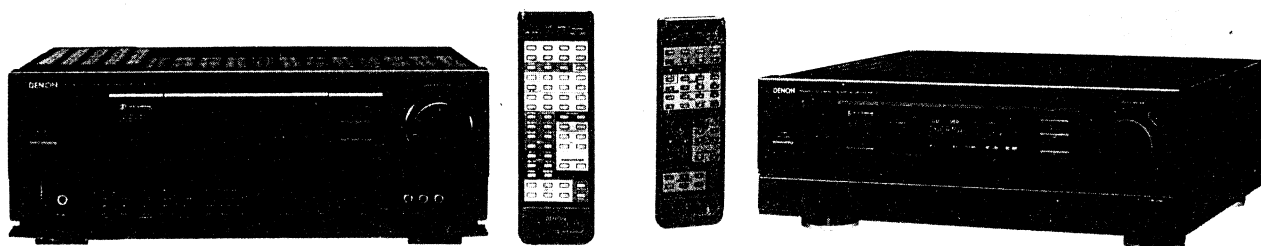

AVC-3020

AVC-2020

CONTENTS

OPERATING INSTRUCTIONS	2 ~ 23
WIRE ARRANGEMENT	24
DISASSEMBLY	25
CIRCUIT DESCRIPTIONS	26, 27
ADJUSTMENT	28
SEMICONDUCTORS	29 ~ 37
PRINTED WIRING BOARD	38 ~ 42
PRINTED WIRING BOARD PARTS LIST	42 ~ 50
BLOCK DIAGRAM	51
WIRING DIAGRAM	52
SCHEMATIC DIAGRAM	53 ~ 56
EXPLODED VIEW OF CHASSIS AND CABINET	56
PARTS LIST OF EXPLODED VIEW	57 ~ 59
REMOTE CONTROL UNIT	60 ~ 62
SCHEMATIC DIAGRAM	60
EXPLODED VIEW	61
PARTS LIST	62
KEY LAYOUT	62







NIPPON COLUMBIA CO., LTD.

SPECIFICATIONS

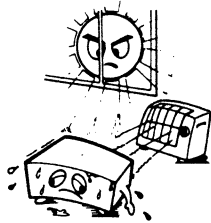
	AVC-3020 For U.S.A. and Canada Models	AVC-2020/2020G For Multi Voltage Model
Audio Section (Power amplifier)		
Rated output:	80 W + 80 W (20 Hz to 20 kHz 8 ohms 0.08% T.H.D.) (Main in – speakers out; 2-channel stereo mode)	80 W + 80 W (20 Hz to 20 kHz 6 ohms 0.08% T.H.D.) (Main in – speakers out; 2-channel stereo mode)
Frequency response:	5 Hz to 50 kHz (Main in – speaker out)	5 Hz to 50 kHz (Main in – speaker out)
Rated input level / impedance:	1 V / 10 k ohms (Main in – speaker out)	1 V / 10 k ohms (Main in – speaker out)
Signal-to-noise ratio:	115 dB (Main in – speaker out)	115 dB (Main in – speaker out)
Output terminals:	Main: A or B 6 to 16 ohms A + B 12 to 16 ohms Center: 6 to 16 ohms Rear: 6 to 16 ohms	Main: 100 W + 100 W (6 ohms EIAJ) Center: 50 W + 50 W (6 ohms EIAJ) Rear: 50 W + 50 W (6 ohms EIAJ)
(Pre-amplifier)		
Line input (Each line input – FRONT PRE OUT)		
Input sensitivity / impedance:	150 mV / 30 k ohms	150 mV / 30 k ohms
Frequency response:	10 Hz to 50 kHz: +0, -3 dB 5 Hz to 100 kHz: +0, -3 dB (VDP DIRECT)	10 Hz to 50 kHz: +0, -3 dB 5 Hz to 100 kHz: +0, -3 dB (VDP DIRECT)
Tone control range:	BASS: 100 Hz ± 10 dB TREBLE: 10 kHz ± 10 dB	BASS: 100 Hz ± 10 dB TREBLE: 10 kHz ± 10 dB
Signal-to-noise ratio (FRONT PRE OUT):	92 dB	92 dB
Distortion factor:	95 dB (VDP DIRECT)	95 dB (VDP DIRECT)
Rated output / Maximum output:	0.01% 1 kHz 3 V (BYPASS mode)	0.01% 1 kHz 3 V (BYPASS mode)
Maximum headphone output:	1 V / 8 V (common for FRONT, CENTER, REAR, MONO, each PRE OUT)	1 V / 8 V (common for FRONT, CENTER, REAR, MONO, each PRE OUT)
Phono equalizer (PHONO input – REC OUT)	284 mW (8 ohms)	284 mW (8 ohms)
RIAA deviation:	20 Hz to 20 kHz ± 1 dB	20 Hz to 20 kHz ± 1 dB
Signal-to-noise ratio:	76 dB (JIS-A, with 5 mV input)	76 dB (JIS-A, with 5 mV input)
Rated output / Maximum output:	150 mV / 8 V	150 mV / 8 V
Distortion factor:	0.03% (1 kHz, 3 V)	0.03% (1 kHz, 3 V)
Video Section		
Standard video jacks		
Input and output level / impedance:	1 Vp-p / 75 ohms	1 Vp-p / 75 ohms
Frequency response:	1 Hz to 10 MHz +0, -3 dB DC to 20 MHz +0, -1 dB (VDP – DIRECT)	1 Hz to 10 MHz +0, -3 dB DC to 20 MHz +0, -1 dB (VDP – DIRECT)
S-video output jacks		
Input and output level / impedance:	Y (brightness) signal: 1 Vp-p / 75 ohms C (color) signal: 0.286 Vp-p / 75 ohms	Y (brightness) signal: 1 Vp-p / 75 ohms C (color) signal: 0.286 Vp-p / 75 ohms
Frequency response:	1 Hz to 11 MHz +0, -3 dB DC to 20 MHz +0, -1 dB (VDP – DIRECT)	1 Hz to 11 MHz +0, -3 dB DC to 20 MHz +0, -1 dB (VDP – DIRECT)
General		
Power supply:	120 V AC, 60 Hz (for U.S.A. and Canada models)	110/220 V AC, 50/60 Hz (for multi-voltage model)
Power consumption:	6.0 A (for U.S.A. and Canada models)	250 W (for multi-voltage model)
Maximum external dimensions:	434 (W) x 160 (H) x 427 (D) mm (17-3/32" x 6-19/64" x 16-13/16") (AVC-3020/2020)	470 (W) x 160 (H) x 427 (D) mm (18-1/2" x 6-19/64" x 16-13/16") (AVC-2020G)
Weight:	15 kg (33 lbs 2 oz) (AVC-3020/2020)	16.2 kg (35 lbs 2 oz) (AVC-2020G)
Remote control unit (RC-134)		
System remote control with learning function		
Total buttons:	60	60
DENON system code		
DAT:	8 buttons	8 buttons
CD player:	8 buttons	8 buttons
Cassette deck:	8 buttons	8 buttons
Tuner:	2 buttons	2 buttons
AVC-3020/2020 fixed codes:	54 buttons	54 buttons
Learning buttons		
System call buttons:	5 (maximum of 15 codes per button)	5 (maximum of 15 codes per button)
Program – Audio:	54 buttons	54 buttons
– Video:	54 buttons	54 buttons
Maximum total:	108 buttons	108 buttons
Batteries:	107 IAA Type (four batteries)	107 IAA Type (four batteries)
External dimensions:	70 (W) x 215 (H) x 35 (D) mm (2-3/4" x 8-15/32" x 1-3/8")	70 (W) x 215 (H) x 35 (D) mm (2-3/4" x 8-15/32" x 1-3/8")
Weight:	230 g (Approx. 8 oz) (including batteries)	230 g (Approx. 8 oz) (including batteries)

* For purposes of improvement, specifications and design are subject to change without notice.

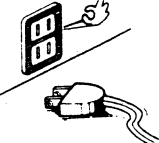
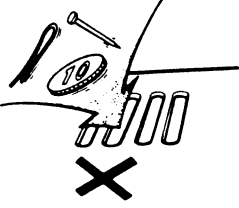
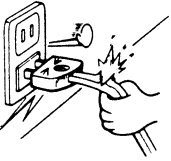
NOTE ON USE

 <p>Be careful of high temperatures</p> <ul style="list-style-type: none"> Do not place the set in a location where it will be exposed to direct sunlight or near a heating appliance. 	 <p>Caution on humidity, water, and dust</p> <ul style="list-style-type: none"> Do not place the set in a location where there is high humidity or a lot of dust. Flower vases or other items containing water should not be placed on top of the set. 	 <p>Do not open the case</p> <ul style="list-style-type: none"> Opening the top cover or the bottom plate of the case and inserting your hand is dangerous. Do not open the case. If some trouble arises with the performance of the set, remove the power plug soon and contact the store where the set was purchased or a nearby dealer.
<p>Caution on rack/cabinet installation</p> <ul style="list-style-type: none"> Avoid installing the set in a closed-type rack. When installing in a rack or cabinet, provide a sufficiently large ventilation opening to promote heat radiation. 	 <p>Care of the case</p> <ul style="list-style-type: none"> Avoid the use of pesticides near the set as well as wiping the case with benzine, thinner or other solvents since they may cause a change in quality or color. Use a soft cloth when wiping away dirt and follow the instructions carefully when using chemically treated cloths. 	 <p>During your absence</p> <ul style="list-style-type: none"> When not using the set for an extended period such as when taking a trip, be sure to disconnect the plug from the receptacle.
 <p>Do not allow foreign matter into the equipment</p> <ul style="list-style-type: none"> Be especially careful of needles, hair pins, and coins getting into the set. 	 <p>Care with the power cord</p> <ul style="list-style-type: none"> When removing the plug from the receptacle, do not pull the power cord; be sure to hold the plug when removing it. 	 <p>Do not block the ventilation holes of the set</p> <ul style="list-style-type: none"> Blocking of the ventilation holes will lead to damage of the set. The ventilation holes are very important for heat radiation from within the set. Care must be taken since placing an object against the holes will result in an extreme rise of temperature within the set.



CAUTION

RISK OF ELECTRIC SHOCK

DO NOT OPEN



CAUTION: TO REDUCE THE RISK OF ELECTRIC SHOCK, DO NOT REMOVE COVER (OR BACK). NO USER SERVICEABLE PARTS INSIDE. REFER SERVICING TO QUALIFIED SERVICE PERSONNEL.



The lightning flash with arrowhead symbol, within an equilateral triangle, is intended to alert the user to the presence of uninsulated "dangerous voltage" within the product's enclosure that may be of sufficient magnitude to constitute a risk of electric shock to persons.



The exclamation point within an equilateral triangle is intended to alert the user to the presence of important operating and maintenance (servicing) instructions in the literature accompanying the appliance.

WARNING: TO REDUCE THE RISK OF FIRE OR ELECTRIC SHOCK, DO NOT EXPOSE THIS APPLIANCE TO RAIN OR MOISTURE.

CAUTION

TO PREVENT ELECTRIC SHOCK DO NOT USE THIS (POLARIZED) PLUG WITH AN EXTENSION CORD, RECEPTACLE OR OTHER OUTLET UNLESS THE BLADES CAN BE FULLY INSERTED TO PREVENT BLADE EXPOSURE.

ATTENTION

POUR PREVENIR LES CHOCS ELECTRIQUES NE PAS UTILISER CETTE FICHE POLARISEE AVEC UN PROLONGATEUR UNE PRISE DE COURANT OU UNE AUTRE SORTIE DE COURANT, SAUF SI LES LAMES PEUVENT ETRE INSEREES A FOND SANS EN LAISSER AUCUNE PARTIE A DECOUVERT.

IMPORTANT SAFEGUARDS

1. Read Instructions – All the safety and operating instructions should be read before the appliance is operated.
2. Retain Instructions – The safety and operating instructions should be retained for future reference.
3. Heed Warnings – All warnings on the appliance and in the operating instructions should be adhered to.
4. Follow Instructions – All operating and use instructions should be followed.
5. Cleaning – Unplug this video product from the wall outlet before cleaning. Do not use liquid cleaners or aerosol cleaners. Use a damp cloth for cleaning.
6. Attachments – Do not use attachments not recommended by the video product manufacturer as they may cause hazards.
7. Water and Moisture – Do not use this video product near water – for example, near a bath tub, wash bowl, kitchen sink, or laundry tub, in a wet basement, or near a swimming pool, and the like.
8. Accessories – Do not place this video product on an unstable cart, stand, tripod, bracket, or table. The video product may fall, causing serious injury to a child or adult, and serious damage to the appliance. Use only with a cart, stand, tripod, bracket, or table recommended by the manufacturer, or sold with the video product. Any mounting of the appliance should follow the manufacturer's instructions, and should use a mounting accessory recommended by the manufacturer.
- 8A. An appliance and cart combination should be moved with care. Quick stops, excessive force, and uneven surfaces may cause the appliance and cart combination to overturn.

9. Ventilation – Slots and openings in the cabinet are provided for ventilation and to ensure reliable operation of the video product and to protect it from overheating, and these openings must not be blocked or covered. The openings should never be blocked by placing the video product on a bed, sofa, rug or other similar surface. This video product should never be placed near or over a radiator or heat register. This video product should not be placed in a built-in installation such as a bookcase or rack unless proper ventilation is provided or the manufacturer's instructions have been adhered to.
10. Power Sources – This video product should be operated only from the type of power source indicated on the marking label. If you are not sure of the type of power supply to your home, consult your appliance dealer or local power company. For video products intended to operate from battery power, or other sources, refer to the operating instructions.
11. Grounding or Polarization – This video product is equipped with a polarized alternating-current line plug (a plug having one blade wider than the other). This plug will fit into the power outlet only one way. This is a safety feature. If you are unable to insert the plug fully into the outlet, try reversing the plug. If the plug should still fail to fit, contact your electrician to replace your obsolete outlet. Do not defeat the safety purpose of the polarized plug.
12. Power-Cord Protection – Power-Supply cords should be routed so that they are not likely to be walked on or pinched by items placed upon or against them, paying particular attention to cords at plugs, convenience receptacles, and the point where they exit from the appliance.

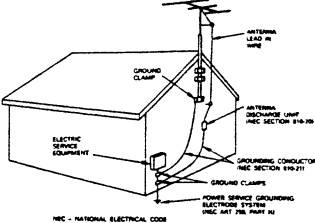

FIGURE 1
EXAMPLE OF ANTENNA GROUNDINGS AS PER NATIONAL ELECTRICAL CODE

NIC - NATIONAL ELECTRICAL CODE
13. Protective Attachment Plug – The appliance is equipped with an attachment plug having overload protection. This is a safety feature. See Instruction Manual for replacement or resetting of protective device. If replacement of the plug is required, be sure the service technician has used a replacement plug specified by the manufacturer that has the same overload protection as the original plug.
14. Outdoor Antenna Grounding – If an outside antenna or cable system is connected to the video product, be sure the antenna or cable system is grounded so as to provide some protection against voltage surges and built-up static charges. Section 310 of the National Electrical Code, ANSI/NFPA No. 70-1984, provides information with respect to proper grounding of the mast and supporting structure, grounding of the lead-in wire to an antenna discharge unit, size of grounding conductors, location of antenna-discharge unit, connection to grounding electrodes, and requirements for the grounding electrode. See Figure A.
15. Lightning – For added protection for this video product receiver during a lightning storm, or when it is left unattended and unused for long periods of time, unplug it from the wall outlet and disconnect the antenna or cable system. This will prevent damage to the video product due to lightning and power-line surges.
16. Power Lines – An outside antenna system should not be located in the vicinity of overhead power lines or other electric light or power circuits, or where it can fall into such power lines or circuits. When installing an outside antenna system, extreme care should be taken to keep from touching such power lines or circuits as contact with them might be fatal.
17. Overloading – Do not overload wall outlets and extension cords as this can result in a risk of fire or electric shock.
18. Object and Liquid Entry – Never push objects of any kind into this video product through openings as they may touch dangerous voltage points or short-out parts that could result in a fire or electric shock. Never spill liquid of any kind of the video product.
19. Servicing – Do not attempt to service this video product yourself as opening or removing covers may expose you to dangerous voltage or other hazards. Refer all servicing to qualified service personnel.
20. Damage Requiring Service – Unplug this video product from the wall outlet and refer servicing to qualified service personnel under the following conditions:
 - a. When the power-supply cord or plug is damaged.
 - b. If liquid has been spilled, or objects have fallen into the video product.
 - c. If the video product has been exposed to rain or water.
 - d. If the video product does not operate normally by following the operating instructions. Adjust only those controls that are covered by the operating instructions as an improper adjustment of other controls may result in damage and will often require extensive work by a qualified technician to restore the video product to its normal operation.
 - e. If the video product has been dropped or the cabinet has been damaged.
 - f. When the video product exhibits a distinct change in performance – this indicates a need for service.
21. Replacement Parts – When replacement parts are required, be sure the service technician has used replacement parts specified by the manufacturer or have the same characteristics as the original part. Unauthorized substitutions may result in fire, electric shock or other hazards.
22. Safety Check – Upon completion of any service or repairs to this video product, ask the service technician to perform safety checks to determine that the video product is in proper operating condition.

- We greatly appreciate your purchase.
- Read these operating instructions carefully to obtain the best performance and a long, trouble-free life from this amplifier. Be sure to keep these operating instructions for future reference.

– CONTENTS –

1	Before Using	4	• Independent recording of video program sources and independent video tape copying 1 and 2	27	
2	Installation Precautions	5	8	Remote Control Unit	28~37
3	Handling Precautions	5	• Part names and functions of the remote control unit	29~33	
4	Connections	6~11	• System code buttons	34	
5	Dolby Pro-logic Surround	12, 13	• System call buttons	35	
6	Part Names and Functions	14~23	• System entry buttons	36, 37	
7	Operation		9	Superimposing	38~40
	• Preparations for playback	24	10	Troubleshooting	40, 41
	• Playback of program sources 1 and 2	25	11	Last Function Memory	41
	• Recording program sources and copying tapes	26	12	Specifications	42
	• Recording video program sources and copying videos	26	13	Note on Use	43
	• Simultaneous recording	26			
	• Monitoring the recording	27			
	• Independent recording of program sources and independent tape copying	27			

Check that the following items are included in the package in addition to the main unit:

- ① Operating Instructions 1
- ② Warranty 1
- ③ Remote control unit (RC-134) 1
- ④ R6P/AA batteries 4
- ⑤ Indication plate 1

1 BEFORE USING

Read the following cautions carefully before using the amplifier:

- Moving the set
Be sure to unplug the power cord and disconnect other cords connecting the amplifier to other audio units before moving the amplifier to prevent damaging or short-circuiting the cords.
- Before turning on the power switch
Check again to make sure that all connections are correct and that there are no problems with the

connection cords. Be sure to turn the power STANDBY before disconnecting or connecting cords.

- Retain the operating instructions
After reading this manual, store it in a safe place.
- The illustrations used in this manual may differ somewhat from the actual amplifier.

• MULTI-VOLTAGE MODEL ONLY

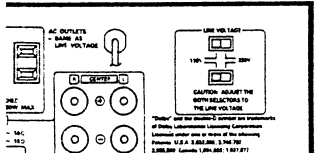

Setting the line voltage

- The customer can set the VOLTAGE SELECTORS on the back panel for appropriate line voltage.
- Do not use excessive force in setting the VOLTAGE SELECTOR KNOB – you may damage it.
- If the VOLTAGE SELECTOR KNOB does not slide smoothly, call qualified service personnel.
- Be sure to set both voltage selectors to same position.

2 INSTALLATION PRECAUTIONS

Using this amplifier or other electronic equipment containing microprocessors simultaneously with a tuner or TV may result in noise in the sound or picture.

If this should happen, take the following steps:

- Install the amplifier as far as possible from the tuner or TV set.
- Keep the antenna lines of the tuner or TV as far as possible from the amplifier's power cord and connection cables.
- This problem is especially frequent when using indoor antennas or 300 ohm feeder lines. We recommend using outdoor antennas and 75 ohm coaxial cables.

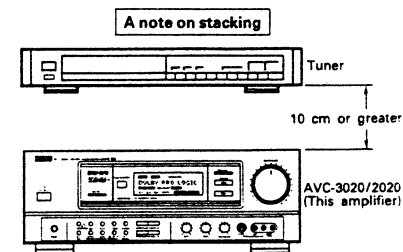

For cooling purposes, do not place another AV component directly on top of the amplifier. Be sure to leave a space of at least 10 cm.

3 HANDLING PRECAUTIONS

• Switching the input function when the input jacks are unconnected

Switching the input function when a component is not connected to the input jacks may result in the generation of click noise. If this should happen, turn down the MASTER VOLUME or connect a component to the input jacks.

• Playback with Dolby Pro-logic

The Dolby Pro-logic position provides optimum effectiveness for sources recorded with Dolby surround. A different surround mode should be selected when playing back sources other than this type. Note in particular that when playing back monaural recording sources, the bypass mode or the simulated mode should be used. Other modes will not provide a suitable effect.

• Muting of the PRE OUT jacks

An electronic muting circuit has been connected to the PRE OUT jacks. This circuit greatly attenuates the output signal for approximately 8 seconds after the power has been switched on. Raising the volume during this operation will result in an extremely large output once the muting has ended, so volume adjustments should be made only after the completion of muting.

• Rear output level while in the surround mode

The rear level will seem small for sources other than Dolby stereo sources. The reason for this is that a rear playback signal is not contained in the software. When playing back such software with a surround function, the mode should be set to something other than Dolby Pro-logic surround. The rear output level may seem small for software having a small rear signal, even Dolby stereo sources.

• Opening and closing the door

This amplifier is equipped with a door on the front panel. Press the "PUSH OPEN△" portion printed at the upper right edge of the door to release and open the door. Likewise, to close the door, press in the same manner until a click sound is heard.

NOTE:

The door will open naturally once it has been released, but it may stop before fully opening. This is not a fault; just lightly push the door open.

4 CONNECTIONS

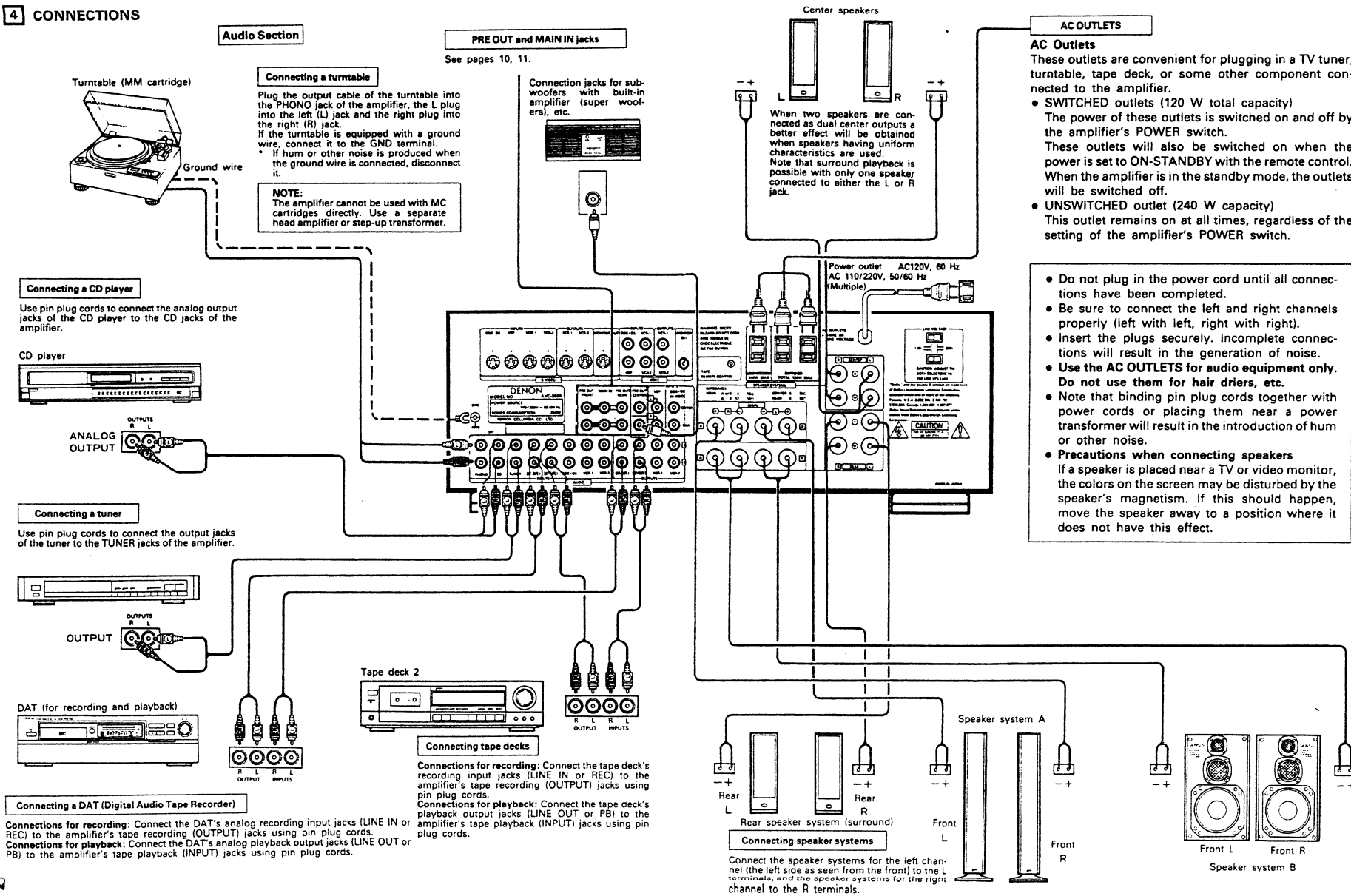

Video Section

Connecting a BS tuner

- Connect the BS tuner's S-output jack to the amplifier's [S-VIDEO] DBS/BS-IN jack using an S-jack connection cord.
- Connect the BS tuner's video output jack to the amplifier's [VIDEO] (yellow) DBS/BS-IN jack using a 75-ohm video coaxial cable pin plug cord.
- Connect the BS tuner's analog audio output jacks to the amplifier's [AUDIO] DBS/BS-IN jacks using pin plug cords.

In addition to the regular DBS/BS jacks, this amplifier is equipped with DBS/BS HI-VISION jacks to be used for future expansion purposes. When FUNCTION is set to DBS/BS, switching the HI-VISION switch on the front panel will provide output of the signals connected to the CENTER and REAR jacks directly from the center and rear speakers.

Connecting a monitor TV

- Connect the TV's S-video input jack to the amplifier's [S-VIDEO] MONITOR OUT jack using an S-jack connection cord.
- Connect the TV's video input jack to the amplifier's [VIDEO] MONITOR OUT jack using a 75-ohm video coaxial cable pin plug cord.

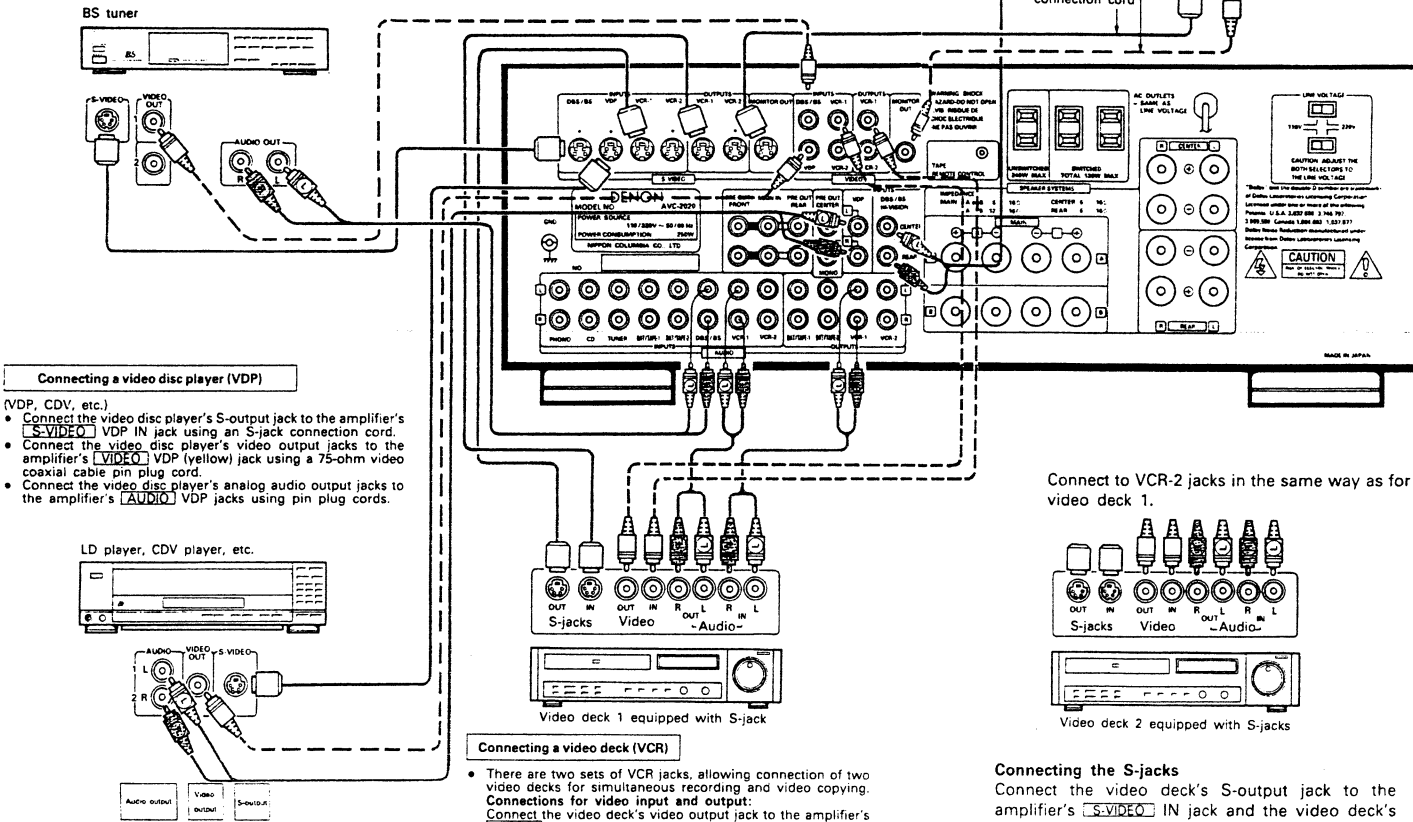

Connecting a video disc player (VDP)

- (VDP, CDV, etc.)
- Connect the video disc player's S-output jack to the amplifier's [S-VIDEO] VDP IN jack using an S-jack connection cord.
 - Connect the video disc player's video output jacks to the amplifier's [VIDEO] VDP (yellow) jack using a 75-ohm video coaxial cable pin plug cord.
 - Connect the video disc player's analog audio output jacks to the amplifier's [AUDIO] VDP jacks using pin plug cords.

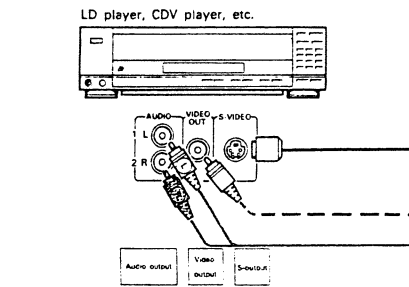

Connecting a video deck (VCR)

- There are two sets of VCR jacks, allowing connection of two video decks for simultaneous recording and video copying. **Connections for video input and output:** Connect the video deck's video output jack to the amplifier's [VIDEO] (yellow) VCR-1 IN jack and the video deck's video input jack to the amplifier's [VIDEO] (yellow) VCR-1 OUT jack using 75-ohm video coaxial cable pin plug cords.

Connecting the S-jacks

Connect the video deck's S-output jack to the amplifier's [S-VIDEO] IN jack and the video deck's S-input jack to the amplifier's [S-VIDEO] OUT jack using S-jack connection cords.

A note on the jacks

- The input selector for the S inputs and that for the pin jack inputs work in conjunction with each other.
- Superimposed displays use only special pin jack signal circuits and will not be displayed to S-jack monitor outputs.
- **Precaution when using S-jacks**
This amplifier's S-jacks (input and output) and pin jacks (input and output) have independent circuit structures, so that signals input from the S-jacks are only output from the S-jack outputs and signals input from the pin jacks are only output from the pin jack outputs. When connecting the amplifier with equipment that is equipped with S-jacks, keep the above point in mind and make connections according to the equipment instruction manuals.

Connecting the audio input and output jacks

- Connect the video deck's audio output jacks to the amplifier's [AUDIO] VCR-1 IN jacks and the video deck's audio input jacks to the amplifier's [AUDIO] VCR-1 OUT jacks using pin plug cords.
- A second video deck may be connected to the VCR-2 jacks in the same way.

The AVC-3020/2020 is equipped with VIDEO AUX jacks on the front panel for playback of video equipment. This is other equipment to be connected. The connection method is the same as that for the VDP.

Speaker System Connections

- This amplifier can accommodate connections of a total of eight speakers including two sets of (front) main amplifier speakers (A and B), one set of rear speakers, and one or two center speakers.
- Connect the speaker terminals with the speakers making sure that like polarities are matched (\oplus with \oplus , \ominus with \ominus). Mismatching of polarities will result in weak central sound, unclear orientation of the various instruments, and the sense of direction of the stereo being impaired.
- When making connections, take care that none of the individual conductors of the speaker cord come in contact with adjacent terminals, with other speaker cord conductors, or with the rear panel.

• Speaker Impedance

- When speaker systems A and B are used separately, speakers with an impedance of from 6 to 16 ohms can be connected.
- Be careful when using two pairs of front speakers (A + B) at the same time, since use of speakers with an impedance outside the range of 12 to 16 ohms will lead to damage.
- Speakers with an impedance of 6 to 12 ohms can be connected for use as center and rear speakers.
- The protection circuit may operate or damage may occur when speakers with an impedance outside of the above range are used.

- 1 Peel off the insulation from the tip of the cord.
- 2 Twist the conductors.
- 3 Turn the speaker terminal counterclockwise to loosen it.
- 4 Insert the exposed portion of wire completely and turn the terminal clockwise to tighten it.

Connecting the speaker terminals
Twist the conductors well or terminate the cord.



Connecting banana plugs

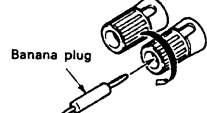

Turn clockwise to tighten, then insert the banana plug.

Speaker connections using the PRE OUT and MAIN IN jacks

These jacks are used when a separate pre-main (power) amplifier is used to amplify the front, rear, and center sounds.

Table of outputs when using the PRE OUT jacks

Diagram number	Jack output / Insertion of shorting pin	MAIN		REAR		CENTER	
		SP-A / SP-B	PRE OUT	SPEAKER	PRE OUT	SPEAKER	PRE OUT
1	FRONT PRE OUT-MAIN IN	FRONT	x	REAR	REAR	CENTER	CENTER
2	REAR PRE OUT-MAIN IN	REAR	FRONT	REAR	x	CENTER	CENTER
3	None	x	FRONT	REAR	REAR	CENTER	CENTER

Using a second pre-main (power) amplifier

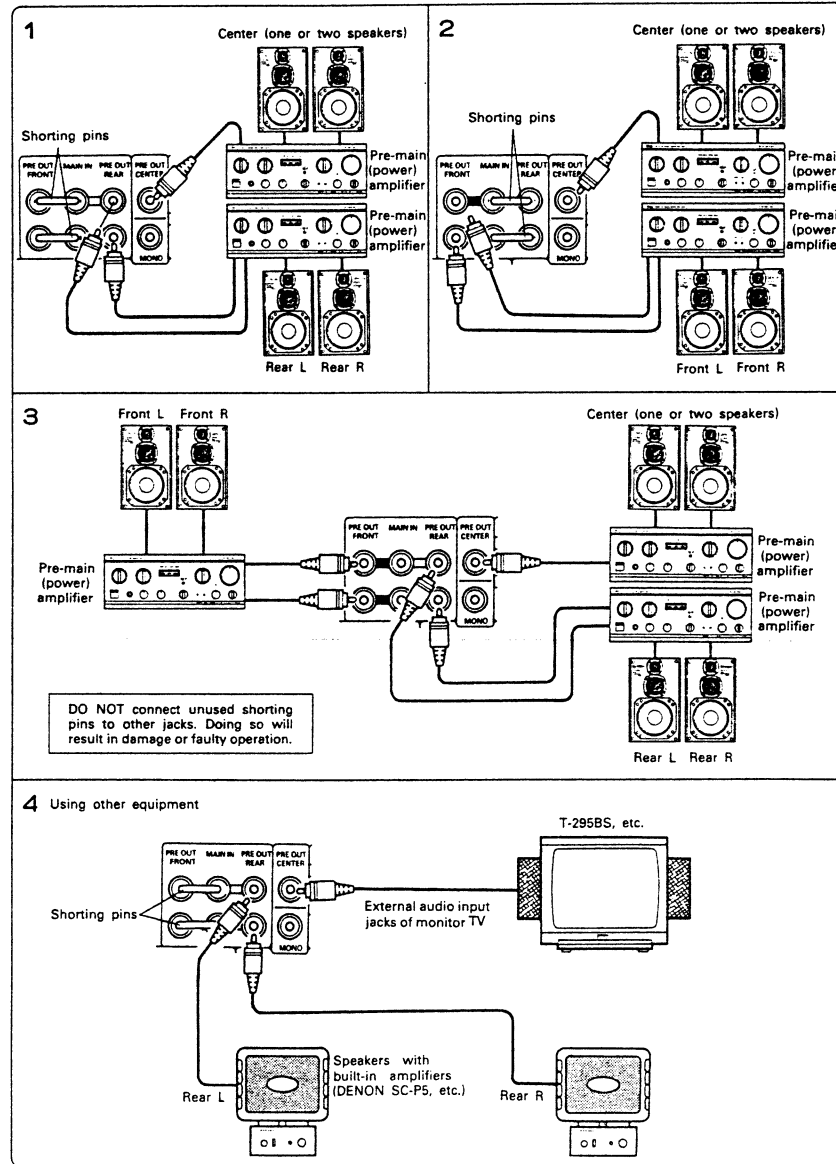

5 DOLBY PRO-LOGIC SURROUND

● Setting the delay time

The optimum delay time will differ depending on the listening position. Referring to the chart at right, set the optimum delay time for your room's space and setting position. For example, when the distance from the front speakers to the listening position is 6 m and that from the rear speakers to the listening position is 4 m, the optimum delay time will be 20 ms.

The variable range of the delay time differs depending on the mode.
For details about the variable range, see Page 14.

● Adjustment of the INPUT BALANCE control

The INPUT BALANCE control must be adjusted for proper Pro-logic reproduction.

1. Auto Balance Mode

When using the Dolby Pro-logic or Spectarea modes, normally set the AUTO BALANCE switch on and this will cause "AUTO BALANCE" to light up on the multi-function display.

2. Manual Mode

When you would like to adjust the INPUT BALANCE control and not use the auto balance function, adjust as follows:

- ① Set the Dolby Pro-logic surround mode.
- ② Set the center mode to center off.
- ③ Play back the speech portion of a film or some other source and adjust the INPUT BALANCE control so that a minimum amount of sound leaks from the front and rear speakers.

- ④ This completes the adjustment.

The center mode can be switched to suit the speaker system.

Listening position and optimum delay time for playback with Dolby Pro-logic surround

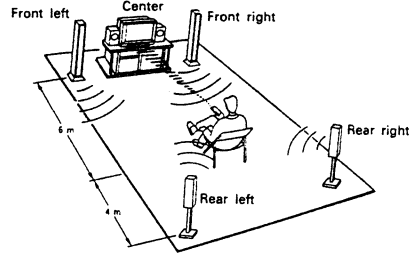
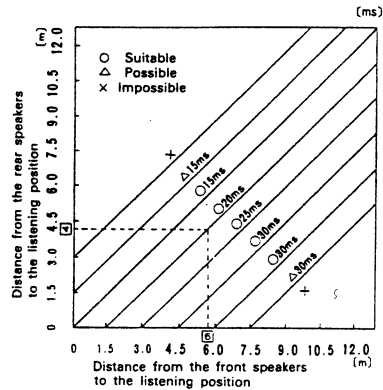

The on-off switching of the speaker outputs (speaker A, speaker B, rear, and center), the setting of the delay time, and the volume adjustment of the rear and center speakers can be set for each surround mode.

Manufactured under license from Dolby Laboratories Licensing Corporation. Additionally licensed under one or more of the following patents: U.S. numbers 3,632,886, 3,746,792 and 3,959,590; Canadian numbers 1,004,603 and 1,037,877. "Dolby" and the double-D symbol \square are trademarks of Dolby Laboratories Licensing Corporation.

● Speaker arrangement and Dolby Pro-logic and the center mode

Ideally, center speakers are used for playback of Dolby Pro-logic surround.

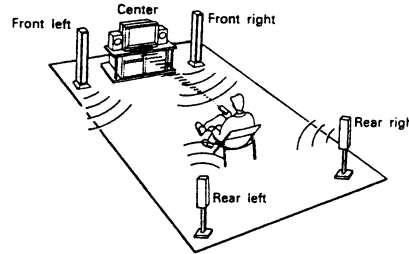

NORMAL mode

Normal mode: This mode is suited for an arrangement in which the center channel speakers are smaller than the left and right speakers. Signals below 100 Hz which have almost no effect on directional orientation are distributed to the left and right channels, whereas the center channel outputs signals greater than 100 Hz. As a result, the bass of the left and right channels increases the apparent depth of the sound.

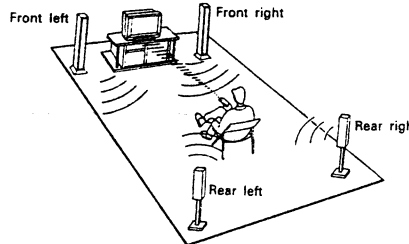

PHANTOM mode

Phantom mode: Use this mode when center channel speakers are not used. A directional emphasis circuit provides signal reproduction which is electrically oriented to the center and this provides an exciting sound field for your enjoyment.

● Test Tone

The test tone function is used to generate a test signal for adjusting the level of each channel in the Dolby Pro-logic surround mode. Before using Dolby Pro-logic surround, arrange the speakers as illustrated above and follow the procedure given here. Using the test tone, set the optimum volume balance for each speaker and set the volume and other controls so that each speaker can be heard at the same level.

In the normal and wide modes the test tone is provided as the speakers are switched in the following order:

→ Front left → Center → Front right → Rear →

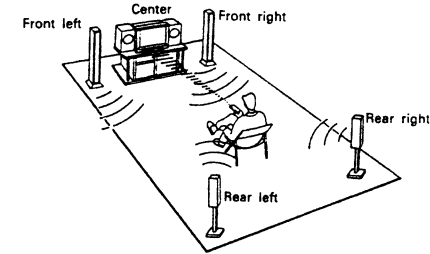

WIDE mode

Wide mode: This mode is suited for an arrangement in which the center channel speakers are of the same grade as the left and right speakers. The entire sound band from low region to high is output to the center channel to provide an exciting sound field for your enjoyment.

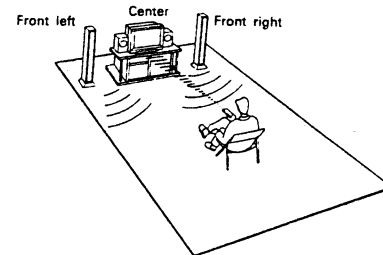

3-CH LOGIC

Three-channel logic mode: Use this mode when rear channel speakers are not used. The rear channel information is fed to the front speakers to provide the surround effect.

Use this signal to adjust the volume balance and set an optimum balance.

In the phantom mode the test tone is provided as the speakers are switched in the following order:

→ Front left → Front left and right → Front right → Rear →

In the 3-ch logic mode the test tone is provided as the speakers are switched in the following order:

→ Front left → Center → Front right →

Note that this amplifier provides the test tone at 4-second intervals for the first two cycles. Use the remote control unit (RC-134) for the adjustment of the test tone.

6 PART NAMES AND FUNCTIONS

Front panel

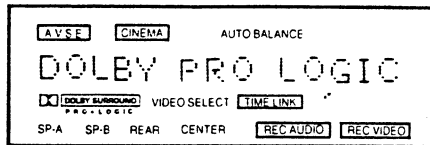
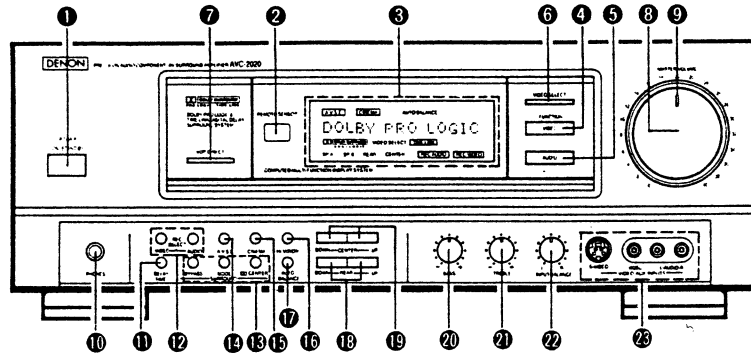

4 Multi-function display
Maximum display of 16 characters.
(See pages 19~23)

Rear panel

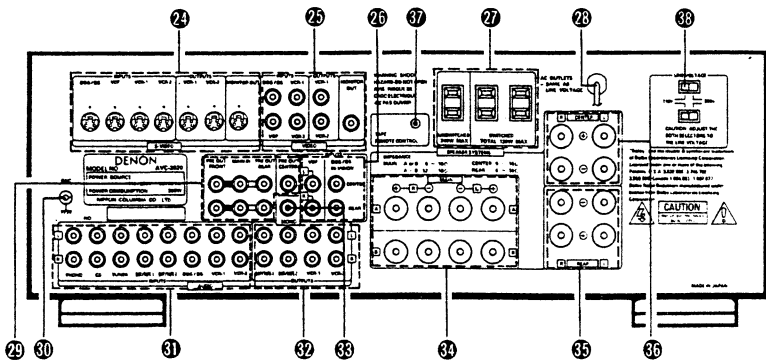

1 POWER switch
• ON

Pressing this button once will switch on the power and the MASTER VOLUME LED 4 will flash on and off (during which time the muting circuit operates to prevent the noise which would otherwise occur when the power switch is at "ON-STANDBY"). Several seconds after the power is switched on the LED will change from a flashing to a steadily lit state, the operation of the muting circuit is cancelled, and the amplifier enters the regular operating condition.

• STANDBY

Pressing the button once again will switch off the power and introduce the standby mode in which the LED of MASTER VOLUME 4 will be lit.

2 REMOTE SENSOR

This is the sensor of the wireless remote control unit. Point the wireless remote control unit (R-134) at this sensor when operating it.

3 Multi-function display

When the power is switched on, the multi-function display shows the surround mode and input/output information. Normally, one of the surround mode displays is shown. When another button is pressed, the display corresponding to that button appears for about 5 seconds. After this, the display returns to the surround mode display. For details on the multi-function display, see Pages 19 to 23.

4 VIDEO FUNCTION selector (Video input selection button)

This button switches the input positions which have video input signals. Pressing this button repeatedly or holding it down will change the input positions in the following order:

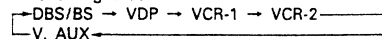

5 AUDIO FUNCTION selector (Audio input selection button)

This button switches the audio input positions. Pressing this button repeatedly or holding it down will change the input positions in the following order:

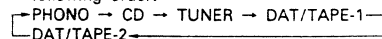

6 VIDEO SELECT (Independent switching button for the video signal)

This button is used to switch the video signals independently of the audio signals. Holding this button down will cause the video input signals to be switched in the order shown below. When the desired video input signal is displayed on the multi-function display, remove your finger from the button. Now, even if the AUDIO FUNCTION selector 5 is switched, the video signal will not change.

To cancel this condition, press the VIDEO SELECT button again or press the VIDEO FUNCTION selector 4.

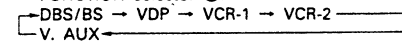

7 VDP DIRECT button

This button is used to provide higher picture quality and higher sound quality of the video and audio signals which are input from equipment connected to the VDP jacks on the rear panel.

Pressing this button switches the amplifier as described below.

• VDP direct standby

This is the standby period until the amplifier enters the VDP direct mode. Holding the button VDP DIRECT button down for about 3 seconds in this state will set the VDP direct mode. Releasing the button part way through will result in a return to the previous state.

• VDP direct: V (VDP video direct)

Holding the button down in the VDP direct standby mode will cause the video signal to bypass the on-screen circuit and other circuits to be output directly to the monitor output. This provides higher quality video reproduction.

* In this condition, video signal output for recording is automatically cancelled so that recording will not be possible by VTR, etc. The on-screen function will also be inoperative so that on-screen checks of the operating condition will not be possible.

Note that in this condition AUDIO REC SELECT (independent recording of the audio) is cancelled automatically and the signals from the equipment currently selected by the AUDIO FUNCTION selector 5 or the VIDEO FUNCTION selector 4 are output to DAT/TAPE-1, DAT/TAPE-2, VCR-1, and VCR-2.

- **VDP direct: V & A**
(VDP video and audio direct)
Pressing the VDP DIRECT button once more in the VDP video direct state will, in addition to the video signals, also bypass the audio signals from circuits which include the surround circuits and tone control circuits and output the signals to the front outputs to provide higher quality audio reproduction.
 - * In this condition, audio signal output for recording is automatically cancelled so that recording will not be possible by tape deck, etc. The surround mode will also be cancelled automatically and only direct playback from the front speakers will be possible.
- **Cancellation of the VDP direct mode**
The VDP direct mode can be cancelled by pressing the VDP DIRECT button one more time in the VDP video and audio direct states or by pressing VIDEO FUNCTION 4 or AUDIO FUNCTION 5

Selecting the VDP direct mode automatically cancels REC OUT SELECT (independent video and audio recording). Also, this mode is automatically cancelled when the power is switched off.

- 8 **MASTER VOLUME control**
Turn the knob clockwise to raise the volume and turn it counterclockwise to lower it.
- 9 **Master volume LED**
This LED flashes during regular operation and during the muting condition. It is lit steadily during the standby condition.
- 10 **PHONES jack**
This jack is used for headphone connections. When you do not wish output from the speakers, switch off the output with the remote control unit or switch off the output of the component connected to PRE OUT.
- 11 **DELAY TIME button**
Press this button to select the delay time. Pressing this button will switch the delay time settings through the range of 0 to 130 ms in 0.5 ms steps and from 30 to 130 ms in 2.0 ms steps.
 - For **DOLBY PRO-LOGIC** in the surround mode:
→ 20 ms → 30 ms → 15 ms →
 - For other surround modes (with the exception of LIVE):
→ 20 ms → 130 ms → 0 ms →

- 12 **REC SELECT**
(Independent switching buttons for audio and video recording outputs)
These buttons provide a selection of the audio recording and video recording modes which is independent of the selection of the FUNCTION selector.
 - **AUDIO button:**
This button selects a signal output to the recording output jacks of DAT/TAPE 1 and 2, as well as VCR-1 and 2.
With regard to the recording output, the signal input normally selected by the FUNCTION selector is output to the recording output side. Use of this button, however, permits selection of a signal from input jacks other than the FUNCTION selector jacks.
 - **VIDEO button**
This button selects a signal output to the recording output jacks of VCR-1 and 2. With regard to the video (audio) recording output, normally the video (audio) signal selected by the VIDEO FUNCTION selector 4 is output. Use of this button, however, permits selection of an input signal other than from the VIDEO FUNCTION selector.

- 13 **SURROUND buttons**
Pressing this button selects the surround mode.
 - **BYPASS button**
Pressing this button will bypass the surround mode to provide regular stereo playback. Rear output will not be provided.
 - **MODE button**
Pressing this button switches the surround mode in the following order:
Priority order

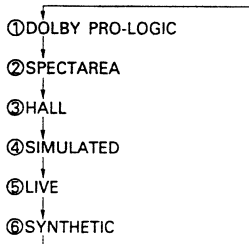

- 14 **DOLBY PRO-LOGIC (surround)**
Use this setting when playing back video software recorded in Dolby surround. Switch the CENTER MODE to suit the speaker system in use.
The delay time may be switched in the range of 15 ms to 30 ms to suit the size of the room and the position of the speakers.

- 15 **SPECTAREA**
Use this setting when playing back movie video software other than that using Dolby surround.
The delay time may be switched in the range of 0 ms to 130 ms.
- 16 **HALL (surround)**
Use this setting to create the atmosphere of a concert hall.
The delay time may be switched in the range of 0 ms to 130 ms.
There will be no output from the center speaker position.
- 17 **SIMULATED**
Use this setting to play back sources recorded in monaural with surround.
There will be no output from the center speaker position.
The delay time may be switched in the range of 0 ms to 130 ms.
- 18 **LIVE**
Use this setting to create the atmosphere of watching a live program in a studio.
The delay time is fixed at 0 ms.
- 19 **SYNTHETIC**
Use this setting to create an atmosphere in which sources recorded in stereo seem to have a further expanded breadth.
The delay time may be switched in the range of 0 ms to 130 ms.
 - **CENTER MODE button**
Press this button when DOLBY PRO-LOGIC has been selected.
When Dolby Pro-logic surround is used during playback, pressing this button will switch the center mode settings in the following order:
→ 1 NORMAL → 2 PHANTOM → 3 WIDE → 4 CENTER OFF →
- 20 **NORMAL:** Select this setting for playback with Dolby Pro-logic surround. This setting is effective when the center channel speakers are smaller than the left and right speakers.
- 21 **PHANTOM:** Select this setting for playback with Dolby Pro-logic surround without using the center speakers.
- 22 **WIDE:** Select this setting when the center channel speakers are of the same grade as the left and right speakers.
- 23 **CENTER OFF:** Select this setting when the input balance is adjusted manually.

See Pages 12 to 13 for information about speaker arrangement and the input balance adjustment method.

- 24 **A.V.S.E. (Bass correction button)**
This button is used to emphasize the bass range of the front speakers.
Setting this switch to ON when using movie video software provides even greater impressiveness. Use this function as desired.
- 25 **CINEMA (Treble correction button)**
This button is used when playing back movie video software and the speech portion is felt to be harsh upon the ears.
This function attenuates the treble range of the center speaker.
The function cannot be used in the Phantom, Hall, Simulated, or Center Off modes.
- 26 **HI-VISION (Hi-Vision input switch for use with BS (broadcast satellite) broadcasts)**
This function is to be used with future satellite broadcasts. The signals connected to the CENTER and REAR of the DBS/BS HI-VISION jacks on the rear panel do not pass through the surround circuits, but are output directly to the center and rear speakers. Note that this switch is effective only when the FUNCTION is set to DBS/BS.
- 27 **AUTO BALANCE (Input balance automatic adjustment button)**
This button can be used with the surround mode is set to Dolby Pro-logic or Spectarea. The button automatically corrects the level difference between the left channel and the right channel of the input signal.
- 28 **REAR LEVEL volume buttons**
Use these buttons to adjust the volume of the rear (surround) speakers.
 - **UP:** Press to increase the volume.
 - **DOWN:** Press to decrease the volume.
 The volume will change only while the UP or DOWN button is pressed, and will stop when the button is released. The change in volume is displayed on the multi-function display or the superimposed display.
These buttons cannot be used in the bypass or Dolby Pro-logic (3-ch logic) modes.

- 19 CENTER LEVEL volume buttons**
- **UP:** Press to increase the volume.
 - **DOWN:** Press to decrease the volume.
- The volume will change only while the UP or DOWN button is pressed, and will stop when the button is released. The change in volume is displayed on the multi-function display or the superimposed display.
- These buttons cannot be used in the following modes: HALL, SIMULATED, PHANTOM mode of DOLBY PRO-LOGIC, and CENTER OFF mode.

- 20 BASS control**
- This control is used to adjust the bass level of the front speaker output or the PRE OUT FRONT jacks.
- The bass is increased when the control is turned clockwise (↻) and decreased when turned counterclockwise (↺).

- 21 TREBLE control**
- This control is used to adjust the treble level of the front speaker output or the PRE OUT FRONT jacks.
- The treble is increased when the control is turned clockwise (↻) and decreased when turned counterclockwise (↺).

- 22 INPUT BALANCE control**
- This control is used to adjust the left/right input balance to provide effective surround playback. The INPUT BALANCE control functions as a front output balance in modes other than Dolby Pro-logic and Spectarea.

See Page 12 for information about the adjustment method.

- 23 VIDEO AUX INPUTS (External video input jacks)**
- Connect the component's S-output jack to the amplifier's S-VIDEO jack with a connection cord designed for S-jacks.
- Connect the component's video output jack to the VIDEO jack with a 75-ohm coaxial cable pin plug cord.
- Connect the component's audio output jacks to the AUDIO jacks with pin plug cords.

- 24 S-VIDEO input/output jacks**

- 25 VIDEO input/output jacks**

- 26 INPUTS (audio input jacks)**

- 27 AC OUTLETS**
See Page 7.

- 28 AC CORD (power cord)**

- 29 PRE OUT (FRONT, REAR, and CENTER), and MAIN IN jacks**
See Page 10.

- 30 GND (ground connection terminal)**
Connect the ground wire of the turntable to this terminal.

- 31 INPUTS (audio input jacks)**

- 32 OUTPUTS (audio output jacks)**

- 33 MONO (monaural output jack)**
This jack is connected to the optional subwoofer or the TV's monaural audio input jack.

- 34 MAIN SPEAKERS (main speaker terminals)**

- 35 REAR SPEAKERS (rear speaker terminals)**

- 36 CENTER SPEAKERS (center speaker terminals)**

NOTE:

Center speaker terminals

This amplifier is equipped with a center channel output which can accommodate dual center speakers.

Pro-logic surround effects can be obtained with only one speaker wired to the left and right terminals, however, the use of two speakers with similar characteristics wired to both sets of left and right terminals will provide a more effective dual center channel output.

- 37 TAPE/REMOTE CONTROL**
- This terminal is exclusively used for sending the remote control signals to the tape deck. Connect it with a 3.5mm mini-jack cord.

NOTE:

Do not hook up a headphones or microphone jack cord. Use this jack to connect a Denon cassette deck with a remote control jack (wired).

If the cassette deck does not have this jack, wired remote control is not possible.

- 38 LINE VOLTAGE (Line Voltage) Switch**
Multi Voltage model only.

Description of the Multi-function Display

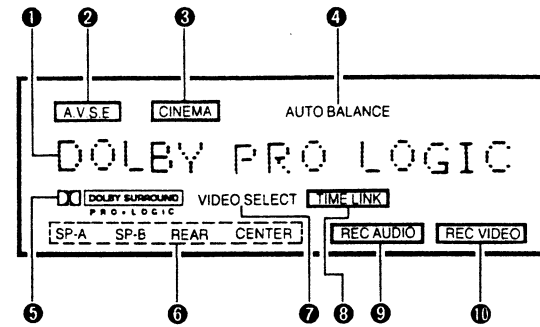

- 1 MULTIFUNCTION DISPLAY**
This display can show a maximum of 16 characters.
With each press of the remote control panel buttons, the set conditions are displayed in order.
Normally, the currently set surround mode is displayed. Display examples are presented on Pages 20 to 23.
- 2 A.V.S.E. indicator**
Pressing the A.V.S.E. button 1 causes this indicator to light up. Pressing the button again switches the indicator off.
- 3 CINEMA indicator**
Pressing the CINEMA button 3 causes this indicator to light up. Pressing the button again switches the indicator off.
Note that this indicator will not light up when the surround mode is set to PHANTOM, HALL, SIMULATED, or CENTER OFF.
- 4 AUTO BALANCE indicator**
Pressing the AUTO BALANCE button 4 causes this indicator to light up. However, it will only light up when the surround mode is set to DOLBY PRO. LOGIC or SPECTAREA.
- 5 DOLBY SURROUND indicator**
This indicator will light up when the SURROUND mode button 5 is pressed and DOLBY PRO. LOGIC is selected.
- 6 OUTPUT CHANNEL indicator**
This indicator shows the channel of the speakers to which the output is currently being sent.
- 7 VIDEO SELECT indicator**
This indicator lights up when the video input signal is selected independently of the audio signal.
- 8 TIME LINK display**
TIME LINK is automatically displayed when the Dolby time link digital delay system operates.
- 9 REC AUDIO indicator**
REC AUDIO is displayed when an audio signal to be recorded is switched independently by the REC OUT SELECTOR.
- 10 REC VIDEO indicator**
REC VIDEO is displayed when a video signal to be recorded is switched independently by the REC OUT SELECTOR.

• **Examples of Multi-function Display Patterns**

The modes shown reflect the states resulting from pressing the buttons on the front panel of the amplifier or by operating the remote control unit (RC-134).

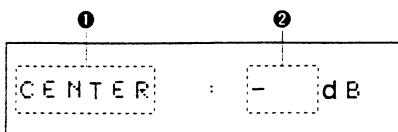
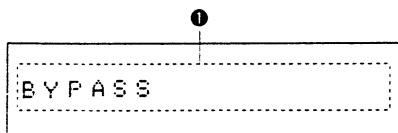
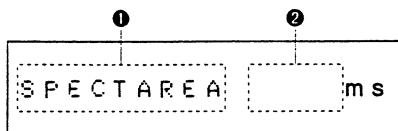
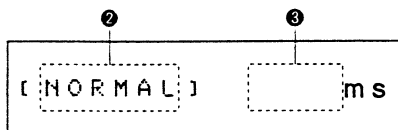
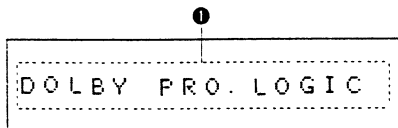

1. SURROUND MODE display

(1) **DOLBY PRO. LOGIC**

- ① DOLBY PRO. LOGIC, DOLBY 3-CH. LOGIC
 - ② NORMAL, PHANTOM, WIDE, CENTER OFF
 - ③ DELAY TIME
- DOLBY PRO. LOGIC settings between 15 ms and 30 ms will be displayed in 0.5 ms steps. DOLBY 3-CH. LOGIC is not displayed.

(2) **Other SURROUND MODE displays**

- These displays will be shown during surround modes such as those listed below. SPECTAREA, HALL, SIMULATED, SYNTHETIC:
- 0 ms to 30 ms settings are displayed in 0.5 ms steps and 30 ms to 130 ms settings are displayed in 2.0 ms steps.
- LIVE: fixed at 0 ms

(3) **BYPASS display**

- ① This display is shown in the bypass mode.

2. CENTER LEVEL display

- ① This display is shown when the CENTER LEVEL button is pressed.
- ② The display is in 2 dB steps from -48 dB (minimum) to 0 dB (maximum).

NOTE:
This display is only shown in modes that use the center speakers.

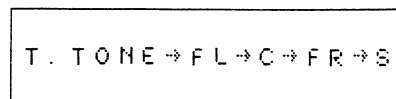
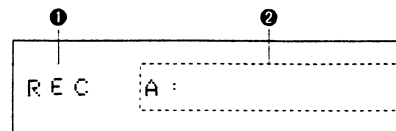
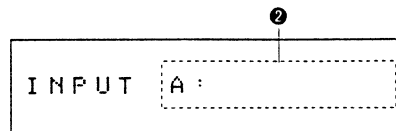
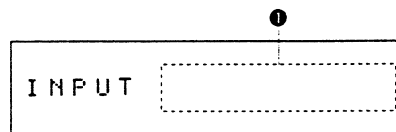
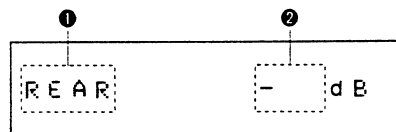

3. REAR LEVEL display

- ① The display will be shown when the REAR LEVEL button is pressed.
- ② The display is in 2 dB steps from -48 dB (minimum) to 0 dB (maximum).

NOTE:
This display is only shown in modes that use the rear speakers.

4. INPUT display

- ① Pressing the FUNCTION button (AUDIO or VIDEO) will cause "INPUT" to be displayed after which the function name will be displayed. When the function name has been preset by system entry, the entry name will be displayed.
- ② When the video signal has already been established with VIDEO SELECT, switching over to AUDIO FUNCTION will result in 3-second displays of the audio input and the video input.

5. REC OUT display

- ① **REC SELECT**
The display will be shown when AUDIO or VIDEO is pressed.
- ② **Audio outputs (A)**
The signals selected from among the following will be displayed: PHONO, CD, DAT/TAPE-1, DAT/TAPE-2, DBS/BS, VDP, VCR-1, VCR-2, and V-AUX. SOURCE is normally displayed.
- ③ **Video outputs (V)**
The signals selected from among the following will be displayed: DBS/BS, VDP, VCR-1, VCR-2, and V-AUX. SOURCE is normally displayed.

6. TEST TONE display

- This display will be shown when the TEST TONE button of the remote control unit is pressed. The arrow mark will move in conjunction with the output. This display will continue until the test tone is switched off.

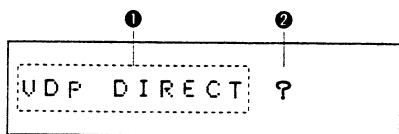

7. VDP DIRECT display

- ① The display will be shown when the VDP DIRECT button is pressed. Holding the button down for 3 seconds or longer will establish the display, and the video direct state will be set. Pressing the button again will also set the audio in the direct state.
- ② The display is shown during VDP DIRECT standby. When established, it will go off, and the VDP DIRECT mode will cause the display to change.

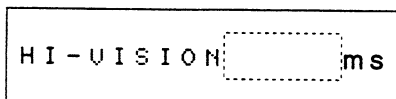

8. HI-VISION display

- When FUNCTION is set to DBS/BS, pressing the HI-VISION button will show the display.

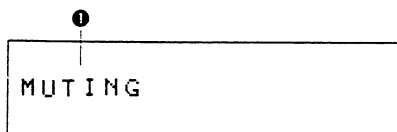

9. MUTING display

- ① This display will be shown when the MUTING button of the included remote control unit is switched on. The display will continue until the muting is cancelled.

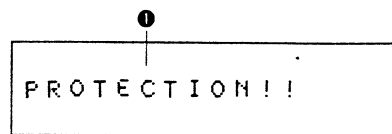

10. PROTECTION display

- ① This display is shown when the protection circuit is activated. See Page 24 for details.

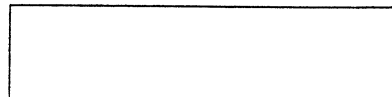

11. MULTIFUNCTION display off

- Follow this procedure when the multi-function display is not required. Holding down the "PANEL" button on the remote control will cause the multi-function display to continue to change and go off at the end. When this condition is set and a switch is operated, the associated display is shown and then the display automatically goes off. To return to the normal display, press the "PANEL" button of the remote control once again.

7 OPERATION

• Preparations for playback

1. Checking connections

- Referring to the connection diagrams (Pages 6 to 11) check to make sure that the connections are made properly.
- Check that the left and right speakers are connected properly and also that the polarity (\oplus , \ominus) is correct.
- Check that the left and right sides of the pin plug cords are connected properly.
- Check that each cord is securely connected.
- Check that each cord is of the proper type.

2. Checking the positions of the controls

- (See Pages 14 to 18 for a reference to the circled numbers.)
- Turn the MASTER VOLUME control fully counterclockwise to the "0" position.
 - Set the INPUT BALANCE Ⓢ , BASS Ⓣ , and TREBLE Ⓡ controls to their center positions.

After making the above checks, press POWER switch Ⓟ to switch on the power. The amplifier will be operable when the LED of the MASTER VOLUME control stops flashing after several seconds of muting.

Note on playback

The sound will be interrupted if one of the FUNCTION selector buttons Ⓢ Ⓣ is pressed during playback. This is due to the operation of the muting circuit which prevents noise from being amplified at the time of switching, and is not a malfunction.

- When using the accompanying remote control unit, press the corresponding button. For details, see Page 28 of Section 8 [REMOTE CONTROL UNIT].

Protection Circuit

This amplifier is provided with a high-speed protection circuit. This circuit protects the internal circuitry from large currents which may be created by the output signals when the speaker terminals are not completely connected or are short-circuited.

The operation of this protection circuit automatically cuts off the output to the speakers and displays "PROTECTION!" on the multi-function display and on the superimposed display. If this should happen be sure to unplug the power cord, check the speaker connections, then plug in the power cord and switch on the power again. If, after another check, the "PROTECTION!" display comes on again, contact your store of purchase.

1. Playback of program sources - 1 (Picture and sound from same source)

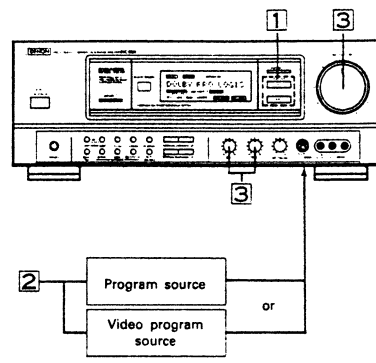

- 1 Select the desired program source by pressing the AUDIO FUNCTION selector button or the VIDEO FUNCTION selector button.

Program source	AUDIO FUNCTION SELECTOR
To listen to a record	PHONO
To listen to a CD	CD
To listen to FM or AM broadcasts	TUNER
To listen to the DAT or tape deck connected to the DAT/TAPE-1 jacks	DAT/TAPE-1
To listen to the DAT or tape deck connected to the DAT/TAPE-2 jacks	DAT/TAPE-2

Video program source	VIDEO FUNCTION SELECTOR
To watch a satellite broadcast	DBS/BS
To watch the video disc player connected to the VDP jacks	VDP
To watch the video deck connected to the VCR-1 jacks	VCR-1
To watch the video deck connected to the VCR-2 jacks	VCR-2
To watch the video camcorder equipped with playback function or another component connected to the (front panel) VIDEO-AUX jacks	V-AUX

- 2 Begin playback of the program source. For operating details, see the manual of the respective component.
- 3 Adjust the volume and tone.

2. Playback of program sources - 2 (Picture and sound from different sources - "Simulcast" playback)

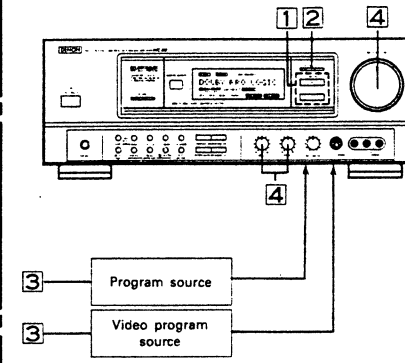

- 1 Select the program source you wish to listen to with the AUDIO FUNCTION selector or the VIDEO FUNCTION selector.
- 2 Hold down the VIDEO SELECT button for the video program source you wish to watch.
- 3 Begin playback of the program sources. For operating details, see the manual of the respective component.
- 4 Adjust the volume and tone.

* Note that when the VIDEO FUNCTION button is again used to select the video program source during Simulcast playback, the Simulcast playback will be cancelled automatically.

**3. Recording program sources and copying tapes
(Recording the audio source currently being monitored)**

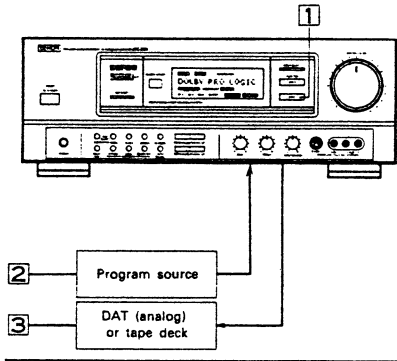

- 1 Press the AUDIO FUNCTION selector (audio input selection buttons) to select the program source you wish to record.

Program source	AUDIO FUNCTION SELECTOR
To record a record	PHONO
To record a CD	CD
To record from the tuner	TUNER
To record from the DAT or tape deck connected to the DAT/TAPE-1 jacks	DAT/TAPE-1
To record from the DAT or tape deck connected to the DAT/TAPE-2 jacks	DAT/TAPE-2

- 2 Begin playback of the program source you wish to record.
- 3 Begin recording on the tape deck or DAT (analog). For operating details, see the manual of the respective component. For instructions on copying tapes, see Page 27.

• Simultaneous recording

The signals from the sources selected by the FUNCTION selector are output simultaneously from the REC OUT jacks of the audio and video systems. If two tape decks and two Hi-Fi video decks are connected and all four components are set to the recording mode, the four components will record the same source simultaneously.

**4. Recording video program sources and copying videos
(Recording the sound and picture of the video source currently being monitored)**

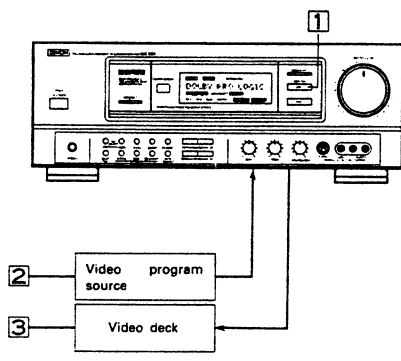

- 1 Press the VIDEO FUNCTION selector to select the program source you wish to record.

Video program source	VIDEO FUNCTION SELECTOR
To record from the BS tuner connected to the DBS/BS jacks	DBS/BS
To record from the video disc player connected to the VDP jacks	VDP
To record from the video tape deck connected to the VCR-1 jacks	VCR-1
To record from the video tape deck connected to the VCR-2 jacks	VCR-2
To record from the video camcorder equipped with playback function or another component connected to the (front panel) VIDEO-AUX jacks	V-AUX

- 2 Begin playback of the video program source you wish to record.
- 3 Begin recording on the video deck. For operating details, see the manual of the respective component.

**5. Independent recording of program sources and independent tape copying
(Recording the sound of a source other than the one currently being monitored)**

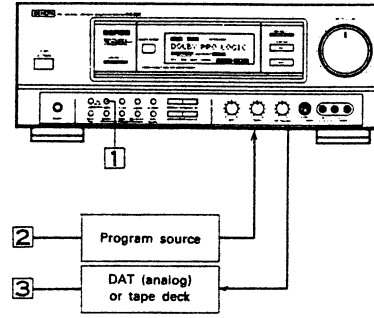

- 1 Hold down the REC SELECT AUDIO button (which independently selects the recording output). Program sources for independent recording will be displayed. Select the audio program source for independent recording by releasing your finger from the button when the desired source is displayed. The display will be switched in the following order:

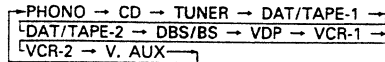

- 2 Begin playback of the program source to be recorded.
- 3 Begin recording on the tape deck or DAT (analog). For operating details, see the manuals of the respective components.
 - * Pressing the REC SELECT AUDIO button again will cancel this mode.

• Monitoring the recording

When making a recording using a 3-head tape deck, the sound that has actually been recorded on the tape can be checked. After completing the above settings, use the AUDIO FUNCTION selector to select DAT/TAPE-1 or -2 to which the 3-head deck is connected.

* Note that 5, 6, and 7 cannot be set during the VDP direct mode.

**6. Independent recording of video program sources and independent video tape copying-1
(Recording the picture of a source other than the one currently being monitored)**

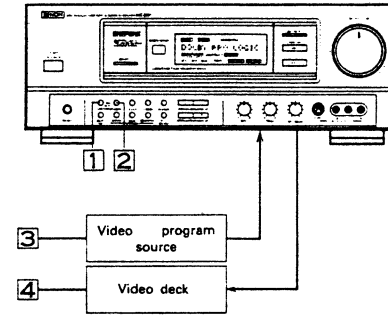

- 1 Hold down the REC SELECT VIDEO button (which independently selects the recording output). Program sources for independent recording will be displayed. Select the video program source for independent recording by releasing your finger from the button when the desired source is displayed. The display will be switched in the following order:

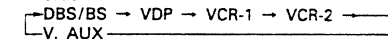

- 2 Begin playback of the video program source to be recorded.
- 3 Begin recording on the video deck. For operating details, see the manuals of the respective components.
 - * Pressing the REC SELECT VIDEO button again will cancel this mode.

**7. Independent recording of video program sources and independent video tape copying-2
(Simulcast recording)**

Combining the above procedures, the video and audio programs of different sources can be recorded (Simulcast recording).

- 1 Hold down the REC SELECT VIDEO button and release your finger when the video program source you wish to record is displayed.
- 2 Hold down the REC SELECT AUDIO button and release your finger when the video program source you wish to record is displayed.
- 3 Begin playback of the program sources.
- 4 Begin recording on the video deck.

8 REMOTE CONTROL UNIT

Following the procedure outlined below, insert the batteries before using the remote control unit.

1. Open the bottom cover of the remote control unit and remove the battery cover.

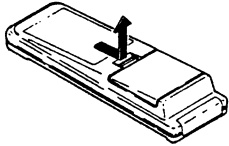

2. Insert the four R6P/AA batteries, matching the ⊕ and ⊖ marks on the batteries with those in the case.

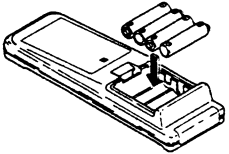

3. Close the bottom cover until it clicks shut.

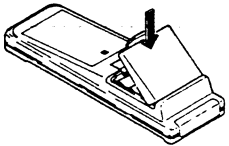

■ Using the remote control unit

The remote control unit uses highly linear infrared rays. Point it at the amplifier's remote sensor when operating it. The amplifier will not operate if the remote sensor is covered or if there is an obstacle between the remote control unit and the sensor.

Also note that strong light shining on the remote sensor may result in mistaken operations. In addition, using the amplifier near neon signs which generate pulse type noise may result in mistaken operations, so keep the amplifier as far as possible from such neon signs.

■ Cautions for batteries

- Be sure that the ⊕ and ⊖ ends of the batteries match the marks on the battery case of the remote control unit.
- Replace weak batteries as soon as possible.
- Do not mix new batteries with used ones.
- Do not use batteries of different types together. Note that some batteries of the same shape and size may provide different performance.
- Some batteries are rechargeable, others are not. Read the battery instructions carefully.
- Do not connect the ⊕ and ⊖ ends of the batteries directly with metal objects. (Do not short-circuit the batteries.)
- Do not disassemble, heat, or dispose of batteries in a fire. If the batteries should leak, carefully wipe off any fluid from the battery case, then insert new batteries.

■ Range of operation of the remote control unit

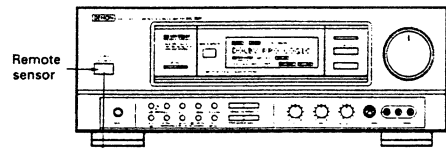

Range of remote control:
Approximately 7 m

If the range of the remote control seems short or the sensitivity poor, the batteries may be weak. Replace the batteries with new ones promptly.

■ A note on battery replacement

Have replacement batteries on hand so that the old batteries can be replaced as quickly as possible when the time comes.

The codes that have been learned may be lost if removed batteries are not replaced within about 5 minutes.

Part names and functions of the remote control unit

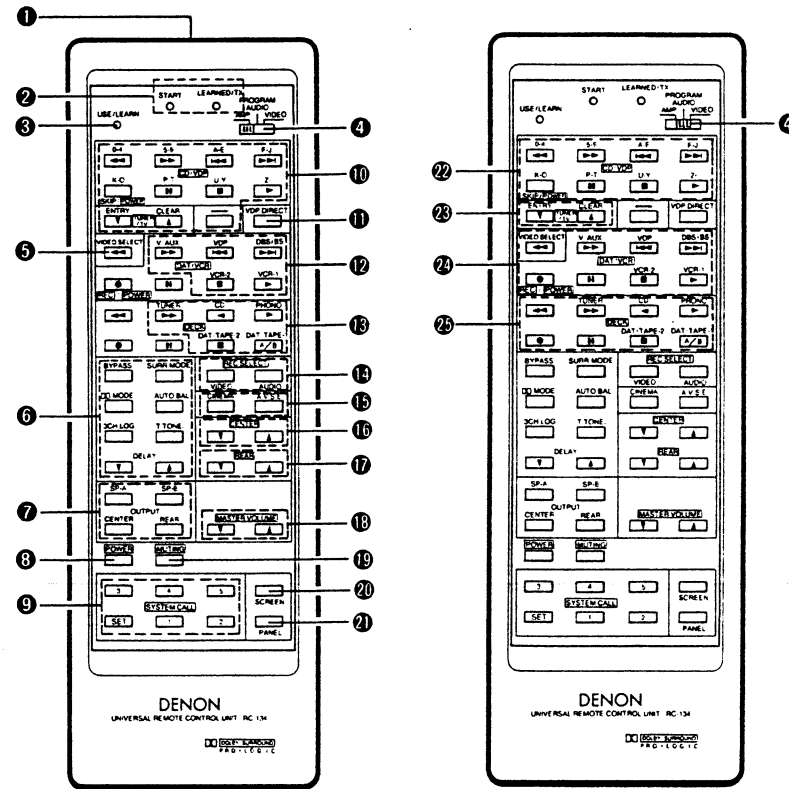

- 1 Transmitting window The remote control signals (infrared rays) are sent from this window.

Display plate:

The display plate for the remote control unit is included in the bag containing the Operating Instructions. Use the display plate when using the learning mode and indicate the codes stored at the different keys. Since the entered characters may rub off, when the display plate is used for a long period of time the characters should be protected with cellophane tape, etc. A pencil eraser may be used to simply erase the button indications when you wish to change them.

Follow the procedure described below to use the learning function of the remote control unit.

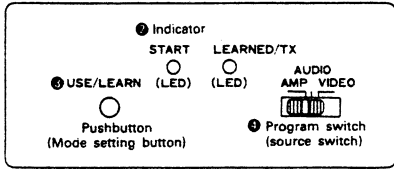

Operation

- USE/LEARN select button ③**
Press this button with the tip of a pen, etc. to set the learn mode.
The START and LEARNED/TX LEDs in the indicator section ② will start flashing to indicate that learning is possible.
- Set the PROGRAM switch to the desired side, PROGRAM AUDIO or VIDEO.
- Hold the transmitting windows of both your remote control unit and the RC-134 facing each other about 5 cm apart.
- Press the button of the RC-134 to which you wish to store the code for 1 to 2 seconds, then release it. The LEDs will stop flashing and the START LED will remain lit.
- Check that the START LED ② is lit, then hold down the corresponding button on the other remote control unit.
- Release the button when the START LED ② goes off and the LEARNED LED lights up. The code has now been stored. The two LEDs will once again start flashing.
Use this procedure to store other codes at other keys.

NOTE:

- If the code cannot be stored, the LEARNED LED will not light after the START LED has gone off. This may occur for a very limited number of models.
- If the memory is overloaded, both LEDs will start flashing rapidly after the START LED lights up. If this happens, no more codes can be stored.
Use the reset operation to re-learn codes.

- Repeat steps 4 through 6 above to store codes at other keys.

- After the learning operations are completed, press the USE/LEARN switch again. The two LEDs will stop flashing and the unit will be in the transmit mode. Check that the stored codes function properly.
The buttons for which learning is possible are 54 buttons with the PROGRAM switch ④ set to AUDIO, and 54 buttons with the PROGRAM switch ④ set to VIDEO, which makes a total of 108 buttons (maximum).

NOTE:

Depending on the type and length of the codes to be learned, it may not be possible to use all 108 buttons for learning.

Clearing operation

For individual sources

- Press the USE/LEARN switch ③ with the tip of a pen, etc., to set the learn mode.
- Set PROGRAM switch ④ to the side of the source you wish to clear (either AUDIO or VIDEO).
- Hold down the **POWER** ⑩ and **REAR** ⑪ buttons at the same time for at least 4 seconds.
- The START and LEARNED LEDs will light for 2 seconds, then go off when all learned codes for that source are cleared.
If the source is PROGRAM AUDIO or VIDEO, the remote control unit will be set to the initial codes (DENON system codes).

For all sources

- Press the USE/LEARN switch ③ with the tip of a pen, etc., to set the learn mode.
- The PROGRAM switch ④ may be set to any one of AMP, AUDIO, or VIDEO.
- Press the **MUTING** ⑬ button and the **REAR** ⑪ button ① at the same time for at least 4 seconds.
- When the START and LEARNED LEDs alternately light up 6 times, all learning codes will have been cleared.
Note the initial codes (DENON system codes) will be set.

Remote control operation

- Check that both LEDs are off.
If both LEDs are flashing or if the START LED is lit, press the USE/LEARN button to switch them off.
- When a remote control operation button is pressed, the LEARNED/TX LED will light and the remote control code will be transmitted.

Description of AVC-3020/2020 code buttons

- VIDEO SELECT**
(Independent switching button for the video signal)
(This button has the same function as the corresponding button on the amplifier.)
This button is used to switch the video signals independently of the audio signals.
Holding this button down will cause the video input signals to be switched in the order shown below. When the desired video input signal is displayed on the multi-function display, remove your finger from the button. Now, even if the AUDIO FUNCTION selector ⑤ is switched, the video signal will not change.
To cancel this condition, press the VIDEO SELECT button again or press the VIDEO FUNCTION selector ④.
DBS/BS → VDP → VCR-1 → VCR-2 → V. AUX

- SURROUND buttons**
(Same function as on amplifier; see Pages 16 to 17.)
 - BYPASS button**
Pressing this button will bypass the surround mode to provide regular stereo playback.
Rear output will not be provided.
 - SURROUND MODE button**
Pressing this button switches the surround mode in the following order:

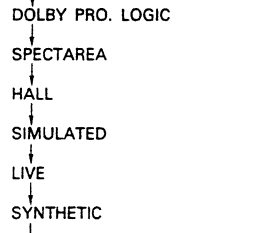

The first selection following BYPASS is DOLBY PRO. LOGIC.

- Dolby Center MODE button**
This button is only effective when the surround mode is set to DOLBY PRO. LOGIC. Pressing this button will switch the Dolby center mode settings in the following order:
NORMAL → PHANTOM → WIDE → CENTER OFF

- TEST TONE button**
This button produces a test signal for adjusting the level of each channel in the Dolby Pro-logic surround mode.
The test tone is switched as follows:
Front left → Center → Front right → Rear

This signal is used for adjusting the volume balance.

For details, see Page 13.

- 3-CH LOGIC button**
This button is used for playing back a video source recorded using Dolby surround without using the rear speakers.
Switching this button on combines the rear speaker audio with that of the front speakers. Pressing the button once more switches this function off and returns the set to normal operation.
- DELAY TIME button**
This button sets the delay time.
This button is only effective when the surround mode is on.
Pressing this button switches the delay time between 0 and 30 ms in 0.5 ms steps and between 30 and 130 ms in 2.0 ms steps. Pressing the ▲ side increases the delay time. Pressing the ▼ side decreases the delay time.
The following sequence is provided in the Dolby Pro-logic mode:

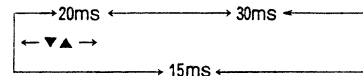

The following sequence is provided in other surround modes (not including LIVE):

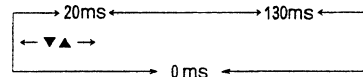

7 OUTPUT buttons

These buttons switch the speaker outputs on and off. The settings are displayed on the multi-function display and the superimposed display.

- SP-A: Operates the speaker system connected to the front speaker output terminals "A."
- SP-B: Operates the speaker system connected to the front speaker output terminals "B."
- CENTER: Operates the speaker system connected to the center speaker output terminals, and the center pre-out terminals.
- REAR: Operates the speaker system connected to the rear speaker output terminals, and the rear pre-out terminals.

8 POWER button (Same function as on amplifier)

If the amplifier is plugged into an AC outlet this button can be used to switch it to ON and STANDBY.

When pressed, the amplifier becomes operative. Pressing the button again activates the last function memory, which holds the settings for the various components as they were immediately before the standby condition, so that there is no need to perform complicated resettings.

When the power is switched off, the power supply to the SWITCHED AC outlets on the rear panel is also turned off.

9 SYSTEM CALL buttons

See Page 35.

10 SYSTEM ENTRY buttons

See Page 34 to 36.

11 VIDEO SELECT button

(Same function as on amplifier.)

Holding down the VDP DIRECT button for 3 seconds or longer will set this mode.

Higher grade video and audio will be provided since the video and audio signals output from the equipment connected to the VDP jacks of the rear panel will be output directly. See Page 15 for details.

12 VIDEO INPUT selection buttons

These buttons select the input signals of the video components.

These buttons select the input signals and switch the video signals.

- DBS/BS: Press this button to use the BS tuner connected to the DBS/BS jack.
- VDP: Press this button to play back the VDP connected to the VDP jack.
- VCR-1: Press this button to play back the video deck connected to the VCR-1 jack.
- VCR-2: Press this button to play back the video deck connected to the VCR-2 jack.
- V-AUX: Press this button to play back a video camcorder equipped with a playback function, or some other component that is connected to one of the front panel jacks.

13 AUDIO INPUT selection buttons

These buttons select the input signals of the audio components.

- PHONO: Press this button to play back the turntable connected to the PHONO jacks.
- CD: Press this button to play back the CD player connected to the CD jacks.
- TUNER: Press this button to play back the tuner connected to the TUNER jacks.
- DAT/TAPE-1: Press this button to play back the DAT or tape deck connected to the DAT/TAPE-1 jacks.
- DAT/TAPE-2: Press this button to play back the DAT or tape deck connected to the DAT/TAPE-2 jacks.

14 REC SELECT buttons (Independent switching buttons for audio and video recording outputs)

(Same function as on amplifier.)

These buttons provide a selection of the audio recording and video recording modes which is independent of the selection of the FUNCTION SELECTOR.

• AUDIO button:

This button selects a signal output to the recording output jacks of DAT/TAPE 1 and 2, as well as VCR-1 and 2.

With regard to the recording output, the signal input normally selected by the FUNCTION SELECTOR is output to the recording output side. Use of this button, however, permits selection of a signal from input jacks other than the FUNCTION SELECTOR jacks.

• VIDEO button

This button selects a signal output to the recording output jacks of VCR-1 and 2. With regard to the video recording output, normally the video signal selected by the VIDEO FUNCTION selection button 4 is output. Use of this button, however, permits selection of a signal from input jacks other than the VIDEO FUNCTION SELECTOR jacks.

15 TONE CONTROL buttons

(Same function as on amplifier.)

• CINEMA (Treble correction button)

This button attenuates the treble range of the center speaker.

The function cannot be used in the Phantom, Hall, Simulated, or Center Off modes.

• A.V.S.E. (Bass correction button)

This button is used to emphasize the bass range of the front speakers.

16 CENTER level control

These buttons are used to adjust the level of the center output.

Pressing the ▲ side button increases the volume of the center level.

Pressing the ▼ side button decreases the volume of the center level.

These buttons cannot be used in the Phantom, Hall, Simulated, or Center Off modes.

17 REAR level control

These buttons are used to adjust the level of the rear output.

Pressing the ▲ side button increases the volume of the rear level.

Pressing the ▼ side button decreases the volume of the rear level.

These buttons cannot be used in the Bypass or 3-ch Logic modes.

18 MASTER VOLUME control

These buttons are used to adjust the master volume level.

Pressing the ▲ side button turns the master volume control of the amplifier clockwise, increasing the overall volume level.

Pressing the ▼ side button turns the master volume control of the amplifier counterclockwise, decreasing the overall volume level.

19 MUTING button

Pressing this button cuts off the outputs from the PRE OUT jacks and the speakers.

The MASTER VOLUME LED will be flashing during the muting condition. Pressing this button once will set the muting, another press will cancel the muting, the next press sets the muting, and so on.

20 SCREEN button

Pressing this button provides a superimposed display of the current operating condition on the monitor screen.

Pressing this button will switch the superimposed display.

For details, see Pages 38 to 40.

21 PANEL button

Pressing this button provides a display of the current operating condition on the multi-function display.

Pressing this button will switch the multi-function display.

For details, see Pages 20 to 23.

• Description of DENON System Code buttons

When the PROGRAM switch ④ is set to AUDIO, the DENON component system code buttons are set to buttons ① through ⑤, and when set to VIDEO, the code buttons are set to ⑥.

When the PROGRAM switch ④ is set to AUDIO

① CD player system buttons

These buttons directly control the DENON remotely-controlled CD players.

The buttons have the same functions as the buttons on the CD player.

▶ PLAY button

Press this button to begin playback.

■ STOP button

Press this button to stop playback.

|| PAUSE button

Press this button to pause.

◀◀ (Manual search reverse button)

▶▶ (Manual search forward button)

Press these buttons for manual search in the forward or reverse directions.

I◀◀ (Auto search reverse button)

▶▶I (Auto search forward button)

Press these buttons for auto search in the forward or reverse directions. Use them to find the beginnings of tracks.

When the PROGRAM switch ④ is set to AUDIO

② VDP system buttons

These buttons directly control DENON LD players and other remotely-controlled LD players. The buttons have the same functions as the buttons on the LD player.

Note that some equipment cannot be operated with this remote control unit.

▶ PLAY button

Press this button to begin playback.

■ STOP button

Press this button to stop playback.

◀◀ (Manual search reverse button)

▶▶ (Manual search forward button)

Press these buttons for manual search in the forward or reverse directions.

I◀◀ (Auto search reverse button)

▶▶I (Auto search forward button)

Press these buttons for auto search in the forward or reverse directions. Use them to find the beginnings of tracks.

③ TUNER system buttons

These buttons directly control tuners equipped for remote control.

▲ PRESET channel up button

▼ PRESET channel down button

These buttons change the preset channel.

④ DAT system buttons

These buttons directly control the DENON remotely-controlled DAT.

The buttons have the same functions as the buttons on the DAT.

▶ PLAY button

Press this button to begin playback.

■ STOP button

Press this button to stop playback.

|| PAUSE button

Press this button to pause.

◀◀ (Manual search reverse button)

▶▶ (Manual search forward button)

Press these buttons for manual search in the forward or reverse directions.

I◀◀ (Auto search reverse button)

▶▶I (Auto search forward button)

Press these buttons for auto search in the forward or reverse directions. Use them to find the beginnings of tracks.

• REC (record button)

Use this button when recording.

⑤ DECK system buttons

These buttons directly control DENON cassette decks equipped for remote control.

The buttons have the same functions as the buttons on the cassette deck.

▶ PLAY (REV) button (forward direction)

Press this button to begin playback in the forward direction.

◀ PLAY button (reverse direction)

Press this button to begin playback in the reverse direction.

■ STOP button

Press this button to stop the deck.

|| PAUSE button

• REC button

These buttons have the same functions as the buttons on the cassette deck.

SELECT-A/B button

Use this button for selection of the deck when using a double deck.

◀◀ REW button

Press this button to rewind the tape.

▶▶ FF button

Press this button to fast-forward the tape.

⑥ SYSTEM CALL buttons

- Using one button the SYSTEM CALL function permits continuous transmission of the codes of previously learned buttons for up to a maximum of 15 buttons.

SYSTEM CALL registration

- Press the **SET** button. The START LED of the indicator section will start flashing.
- Set the PROGRAM ④ button and then press up to 15 buttons that you would like to set to system call operation in the order that you wish to send them. Each time a button is pressed the LEARNED/TX LED will light. (The maximum number of buttons that can be stored is 15.)
- Press one button you wish to have stored from among buttons ① through ⑤.
- The START LED will go out and the buttons will have been registered.
- Up to five buttons (① through ⑤) can be registered. To continue the procedure and register another button, repeat the operations of steps 1 through 4.

NOTE:

The contents of the pressed buttons will also be sent during system call registration and so the transmitting window should be covered or some other precaution taken to avoid unwanted operation of the amplifier.

SYSTEM CALL cancellation

- Press the **SET** button and the START LED will begin flashing.
- Press the button you wish to cancel among buttons ① through ⑤.
- The START LED will go out and the button will be reset.
- To continue the procedure and reset another button, repeat the operations of steps 1 through 3.

Using the SYSTEM CALL function

- Press once one of the ① through ⑤ buttons that have been registered for system call use.
- The LEARNED/TX LED will light. The remote control codes will be sent in the registered order approximately every 1.5 seconds.
- The LEARNED/TX LED will go out and the transmission will be completed.

SYSTEM ENTRY buttons

- The system entry function is used in conjunction with the function buttons and permits the names of the equipment used or some other information (up to 8 characters) to be stored and displayed. (Example: CD → DCD-1430, DAT/TAPE-1 → DR-70G, etc.)

Button names

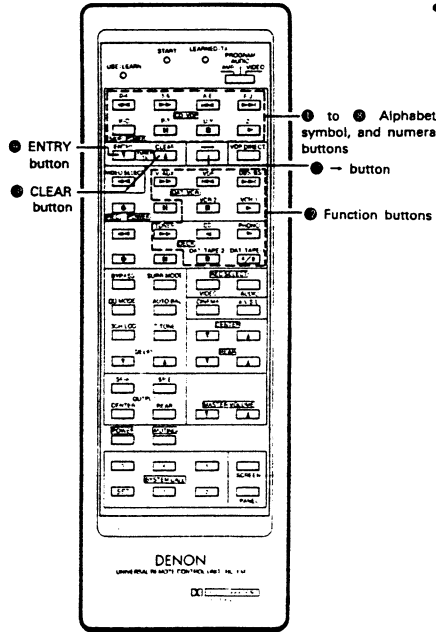

- Description of the remote control buttons used for system entry

① 0-4	→ 0 → 1 → 2 → 3 → 4
② 5-9	→ 5 → 6 → 7 → 8 → 9
③ A-E	→ A → B → C → D → E
④ F-J	→ F → G → H → I → J
⑤ K-O	→ K → L → M → N → O
⑥ P-T	→ P → Q → R → S → T
⑦ U-Y	→ U → V → W → X → Y
⑧ Z - .	→ Z → - → .

- ⑨ ENTRY Used when starting and completing storage of the system entry.
- ⑩ CLEAR Used when resetting the system entry.
- ⑪ → Input character setting button
- ⑫ Function Selects the button to which system entry is set.

NOTE:
When a button input has not been made for about 20 seconds during system entry, the system entry will automatically be completed.

SYSTEM ENTRY (registration)

Figure 1

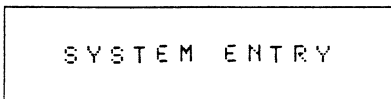
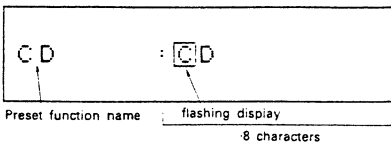

Figure 2



- Example: Enter DCD-1530 to CD.
- Set the PROGRAM switch to AMP.
 - Press the ENTRY key ⑨.
A display such as that shown in Figure 1 will appear on the multi-function display of the amplifier.
 - When the CD button ⑫, to which system entry is desired, is pressed within 10 seconds, the CD and flashing display will appear as shown in Figure 2.
 - To input the letter D, press the A-E button ③ four times and the D will be displayed. Pressing the → ⑪ will input the D and the flashing space will move to the right.

Figure 3

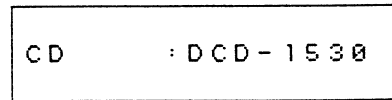
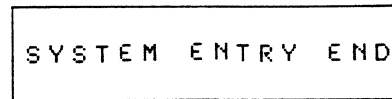
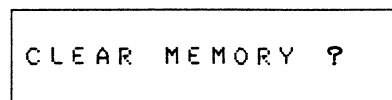

Figure 4



SYSTEM ENTRY CLEAR method

Figure 5



Superimposed display

Figure 6

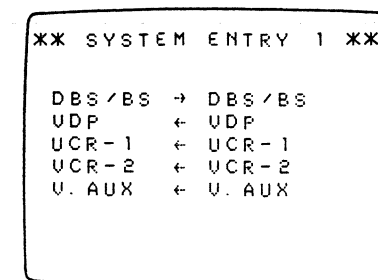
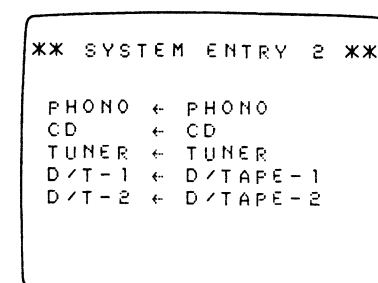

Figure 7



- To input the letter C, press the A-E button ③ three times and the C will be displayed. Pressing the → ⑪ button will input the C and the flashing space will move to the right.
- To input the letter D, press the A-E button ③ four times and the D will be displayed. Pressing the → ⑪ button will input the D and the flashing space will move to the right.
- Using the same method, enter the remaining characters by pressing the alphabet, symbol, and numeral buttons ① through ⑧ for the hyphen, 1, 5, 3, and 0. (See Figure 3.)
- Pressing the function button CD once again will store the contents in the currently registered function CD.
- Repeat steps 1 through 8 and store the system entry to another function button.
- Hereafter, the function display will be displayed as the name entered in the system entry.
- Press the ENTRY button and complete the operation.
- The same procedure is used to change registered contents.

For one function button at a time

- Press the ENTRY button ⑨.
- Press the function button ⑫ you wish to clear and it will be displayed.
- Pressing the CLEAR button ⑩ will delete the system entry.

For all function buttons

- Press the ENTRY button ⑨.
- Pressing the CLEAR button ⑩ will make the display of Figure 5 appear. Holding the button down for 4 more seconds will delete all of the system entries.
- After the system entries have been cleared, press the ENTRY ⑨ button when completing the ENTRY operation.

- System entries will be shown on the superimposed display the same as on the multi-function display. When selecting DBS/BS through V. AUX of the VIDEO INPUT selector buttons with the function button, the contents of Figure 6 will be displayed. Similarly, when selecting PHONO through DAT/TAPE-2 of the audio INPUT selector buttons with the function button, the contents of Figure 7 will be displayed.

9 SUPERIMPOSING

The operating condition of the amplifier is displayed on the monitor TV when the power is switched on, when the SCREEN button of the remote control unit is pressed, when buttons are pressed, and at other times. When the power is switched on and the SCREEN button of the remote control unit is pressed, displays such as the following will appear.

With repeated presses of the SCREEN button the display will change in the following order: screen 1 → screen 2 → screen 3 → system entry display → OFF (and a repetition of this sequence).

For details on the system entry display, see Pages 36 to 37.

Note that when the power is switched on, screens 1 and 2 will be displayed for about 6 seconds and then go off automatically.

At the time of normal button operation, only the display pertaining to the pressed button is displayed for about 4 seconds and then goes off automatically.

NOTE:

- Superimposed displays will not be output to S-jack monitor outputs and video signal outputs used for recording.
- For video inputs selected by a VIDEO INPUT selector button, the color background of the video will be cancelled following the completion of the superimposed display.

Screen-1 A.V.S.E. and CINEMA displays

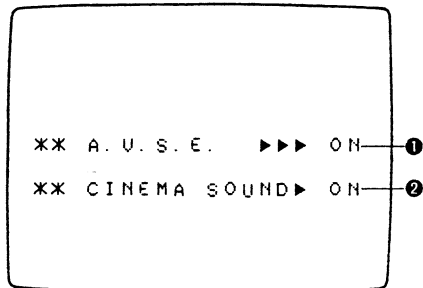

- 1 **A.V.S.E. display**
Displays the condition of the A.V.S.E. switch.
- 2 **CINEMA display**
Displays the condition of the CINEMA switch. Note that this display will only be shown for modes which use the center speakers.

Screen-2 INPUT & REC OUT display

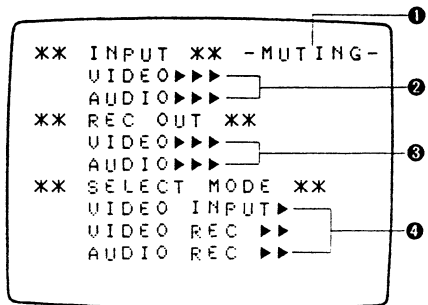

- 1 **Muting display**
Flashes when the muting function is on.
- 2 **INPUT SELECTOR display**
Displays the amplifier's inputs using abbreviations, etc. (When processed for system entry, the registered name is displayed.)
- 3 **REC OUT SELECTOR display**
Displays the recording output. (When processed for system entry, the registered name is displayed.)
- 4 **SELECT MODE display**
Is displayed when the REC OUT SELECT mode, VIDEO SELECT mode, and other select modes are specified.

Screen-3 SURROUND & OUTPUT display

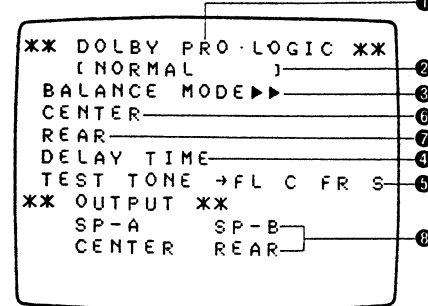

- 1 **SURROUND MODE display**
Displays the surround mode.
- 2 **CENTER MODE**
The center mode is displayed only when the surround mode is set to Dolby Pro-logic.
- 3 **BALANCE display**
Displays the volume balance as auto or manual.
- 4 **DELAY TIME display**
Displays the delay time. There is no display in the BYPASS mode.
- 5 **T. TONE display**
A display is provided when the test tone is on.
- 6 **CENTER LEVEL display**
Displays the center level when a surround mode other than the Dolby Pro-logic Phantom, Hall, or Simulated is selected. The ■ marks increase as the level is raised.
- 7 **REAR LEVEL display**
Displays the rear level as ■ marks. There is no display in the bypass mode or at the time of Dolby 3-ch logic.
- 8 **OUTPUT display**
Displays the various outputs when they are on.

NOTE:

Character screen wavering of the superimposed display

Depending on the video equipment and software, some of the characters of the superimposed display may be unstable due to noise or poorly adjusted tracking of the video equipment. Should this happen, adjust the tracking of the video equipment.

1. PROTECTION display

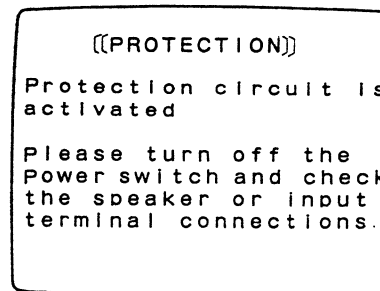

- 1 **PROTECTION (circuit) display**
This display appears when the protection circuit is activated. See Page 24 for details.

2. VDP DIRECT display

(VDP DIRECT)
STAND-BY

The Audio and Video record output signals are disabled when the VDP DIRECT function is on.

- ① **VDP DIRECT display**
Displayed during the standby period until the amplifier enters the VDP direct mode. Upon entering the VDP direct mode, this display is cancelled and the on-screen functions cease to operate.
See Pages 15 to 16 for details.

10 TROUBLESHOOTING

If a problem should arise, first check the following:

1. Are the connections correct?
2. Have you operated the amplifier according to the Operating Instructions?
3. Are the speakers, turntable, and other components operating properly?

If the amplifier is not operating properly, check the items listed in the table below. Should the problem persist, there may be a malfunction. Disconnect the power immediately and contact your store of purchase.

	Symptom	Cause	Measures	Page
Common problems arising when listening to the CD, records, tapes, and FM broadcasts	LED not lit and sound not produced when power switch set to on.	<ul style="list-style-type: none"> Power cord not plugged in securely. 	<ul style="list-style-type: none"> Check the insertion of the power cord plug. 	6-11
	LED lit but sound not produced.	<ul style="list-style-type: none"> Speaker cords not securely connected. OUTPUT button is off. Improper position of the audio input selection button. Volume control set to minimum. MUTING is on. 	<ul style="list-style-type: none"> Connect securely. Select SP-A, SP-B, CENTER, or REAR of the remote control's OUTPUT button. Set to a suitable position. Turn volume up to suitable level. Switch off MUTING. 	6 29 24-27 14-16 33
	LED continues flashing.	<ul style="list-style-type: none"> Speaker terminals are short-circuited. Incomplete connection of the shorting pin between PRE OUT and MAIN IN. 	<ul style="list-style-type: none"> Switch power off, connect speakers properly, then switch power back on. Connect shorting pin properly. 	7 11
	Sound produced only from one channel.	<ul style="list-style-type: none"> Incomplete connection of speaker cords. Incomplete connection of input/output cords. Left/right balance is off. 	<ul style="list-style-type: none"> Connect securely. Connect securely. Adjust balance knob properly. 	7 6-11 18
	Positions of instruments reversed during stereo playback.	<ul style="list-style-type: none"> Reverse connections of left and right speakers or left and right input/output cords. 	<ul style="list-style-type: none"> Check left and right connections. 	6-11

	Symptom	Cause	Measures	Page
When playing records	Humming noise produced when record is playing.	<ul style="list-style-type: none"> Ground wire of turntable not connected properly. Incomplete PHONO jock connection. TV or radio transmission antenna nearby. 	<ul style="list-style-type: none"> Connect securely. Connect securely. Contact your store of purchase. 	6-7 6-7 -
	Howling noise produced when volume is high.	<ul style="list-style-type: none"> Turntable and speaker systems too close together. Floor is unstable and vibrates easily. 	<ul style="list-style-type: none"> Separate as much as possible. Use cushions to absorb speaker vibrations transmitted by floor. If turntable is not equipped with insulators, use audio insulators (commonly available). 	- -
	Sound is distorted.	<ul style="list-style-type: none"> Stylus pressure too weak. Dust or dirt on stylus. Cartridge defective. 	<ul style="list-style-type: none"> Apply proper stylus pressure. Check stylus. Replace cartridge. 	- - -
	Volume is weak.	<ul style="list-style-type: none"> MC cartridge being used. 	<ul style="list-style-type: none"> Replace with MM cartridge or use a head amplifier or step-up transformer. 	6
Remote control unit	Amplifier does not operate properly when remote control unit is used. (When LEARNED/TX LED is lit)	<ul style="list-style-type: none"> Batteries dead. Remote control unit too far from amplifier. Obstacle between amplifier and remote control unit. Learning process to the button improper. Different button is being pressed. 	<ul style="list-style-type: none"> Replace with new batteries. Move closer. Remove obstacle. Set learning again. Press the proper button. 	28 28 28 30 30
	Amplifier does not operate properly when remote control unit is used. (When LEARNED/TX LED is not lit)	<ul style="list-style-type: none"> Learning process to the button improper. Learning process has not been applied to the button. Batteries dead. ⊕ and ⊖ ends of battery inserted in reverse. Improper position of PROGRAM switch. 	<ul style="list-style-type: none"> Set learning again. Apply learning process. Replace with new batteries. Insert batteries properly. Set to desired position (AMP, AUDIO, or VIDEO). 	30 30 28 28 30
	"PROTECTION" display appears on superimposed display and multi-function display.	<ul style="list-style-type: none"> Improper speaker cord connection. 	<ul style="list-style-type: none"> Connect speaker cord properly. 	24, 38

11 LAST FUNCTION MEMORY

- This amplifier is equipped with a last function memory which stores the input and output setting conditions as they were immediately before the power is switched off. This function eliminates the need to perform complicated resettings when the power is switched on.
- This amplifier is also equipped with a back-up memory. This function provides approximately one day of memory storage with the power cord disconnected.

WIRE ARRANGEMENT

In case wires require unclamping or loosening to move the location to perform adjustment or part replacement, be sure to arrange them neatly to restore properly in the same location as they were originally placed. Or, it may occasionally cause to occur a noise.

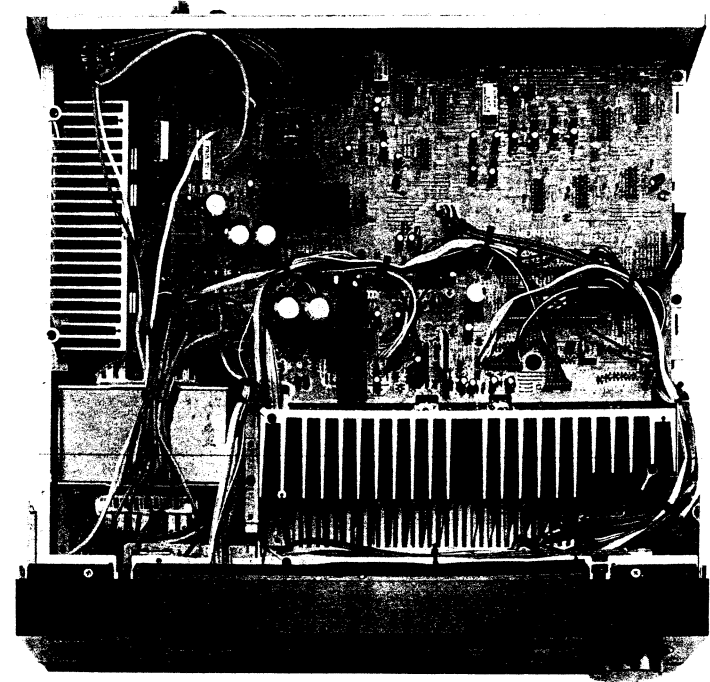

Note: Photo Shows wiring diagram for Asian Models, For U.S.A model, The power transformer is Substituted by a toroidal transformer and the voltage selector portion is deleted.

DISASSEMBLY

(To reassemble reverse disassembly)

1. Top Cover

Remove 9 screws, and pull up the top cover to arrow direction.

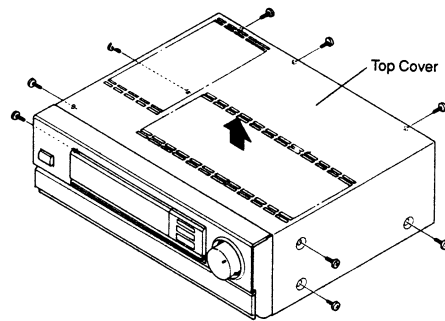
**2. Front Panel**

(1) Remove 4 screws on the both sides, and pull the side escutcheon.

(2) Remove 3 upper screws on Top Cover and 2 lower screws on Bottom Cover, then remove 5 hooks on the upper and middle stages, and pull the front panel to arrow direction.

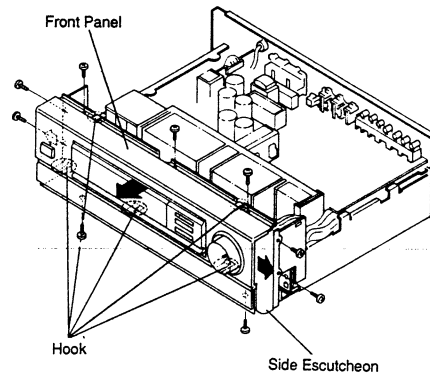
**3. Front Subpanel**

(1) Remove 1 screw from the side and pull the trap door.

(2) Remove a main volume control knob and remove a push-rievet from inside of the main volume control knob and detach LED PCB.

(3) Remove 2 upper hooks and pull the front subpanel to arrow direction.

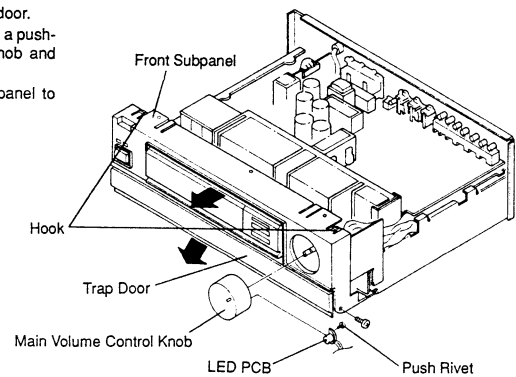
**4. Front Chassis**

(1) Remove 4 nuts.

(2) Remove 7 front screws ① and 2 lower screws ②.

(3) While removing hooks on the both sides to arrow direction, pull the front chassis.

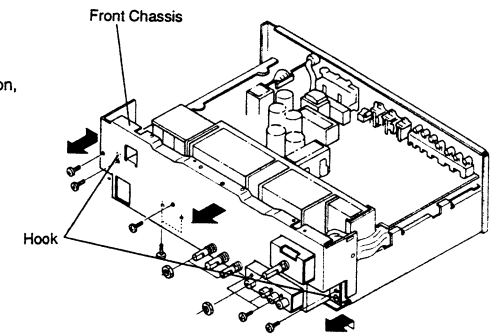
**5. Back Panel**

Remove 23 rear screws and 2 lower screws, and pull the back panel to arrow direction.

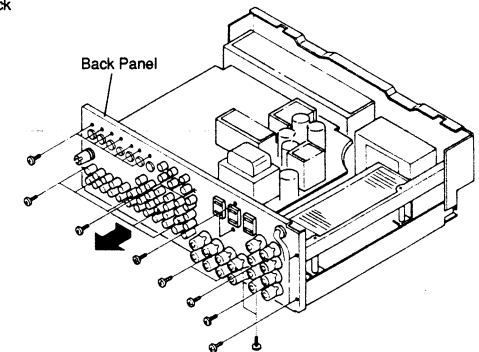

CIRCUIT DESCRIPTION

1. SYNCHRONOUS SIGNAL DISCRIMINATION & SEPARATION

TR713 sets ON at synchronous signal of the video signal. IC711 determines whether the synchronous signal is correct or not and separates the synchronous signal. When the synchronous signal separated by TR713 is correct, pin ⑥ outputs "High", if not correct (no video signal input or the video signal includes noise, etc.) pin ③ outputs "Low". When the "Low" output is applied to microcomputer (IC810), IC704 (M50554-001SP) is set to internal video color back.

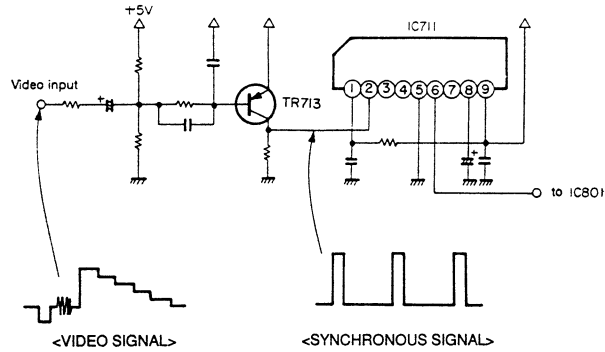

Figure 1

2. SURROUND CIRCUIT

(1) Table below shows output in each surround mode. Changes of output signal with select modes.

Table 1

SELECT MODE Condition	• NORMAL MODE (No select mode)			• VIDEO SELECT			• AUDIO REC			• VIDEO SELECT • AUDIO REC			• VIDEO SELECT • AUDIO REC • VIDEO REC			• VDP DIRECT			
	AUDIO MONITOR	VIDEO REC OUT	VIDEO REC OUT	AUDIO MON	VIDEO MON	AUDIO REC	AUDIO MON	VIDEO MON	AUDIO REC	AUDIO MON	VIDEO MON	AUDIO REC	AUDIO MON	VIDEO MON	AUDIO REC	AUDIO MON	VIDEO MON	AUDIO REC	V. REC
AUDIO FUNCTION	○	×	○	○	△	○	□	×	△	△	△	□	△	△	△	△	△	△	△
VIDEO FUNCTION	○	○	○	○	○	○	○	○	△	△	△	○	○	△	△	△	△	△	△
VIDEO SELECT	△	○	△	△	○	△	△	□	△	△	△	△	□	△	△	△	△	△	△
AUDIO REC SELECT	△	△	○	△	△	□	×	△	△	△	△	△	△	□	△	△	△	△	△
VIDEO REC SELECT	△	△	○	△	△	○	○	△	△	△	△	△	△	□	△	△	△	△	△
VDP DIRECT	VDP (RELAY)	×	×	VDP (RELAY)	×	×	VDP (RELAY)	×	×	VDP (RELAY)	×	×	VDP (RELAY)	×	×	VDP (RELAY)	×	×	VDP (RELAY)

○ Changes with other signal. □ Changes independently. △ No Change. × Turns OFF. () shows the resultants.

Audio signal control status (Using SSM-2125)

MODE	Surround mode signal control														Output Control				SSM-2125 (PRO. LOGIC)										
	LC7823 "L" Control Contents							SSM-2125 (PRO. LOGIC)		LV 1000	HD4152 (CENTER/REAR)			Delay Time Changeable range				DM ₁	DM ₂	DM ₃	DM ₄								
	1	2	3	4	5	6	7	CM ₁ Res	CM ₂ Res	(DELAY MUTE) DO	PASS /NR	R ₃₀	R ₃₁	L	H	L	L	D ₁₁ SP-A	D ₁₂ SP-B	D ₁₃ CENTER	D ₁₄ REAR	NOISE R ₅₀	R ₅₁	R ₅₂	R ₅₃				
BYPASS	○		○			○	L	L	H	H	H	H			○		H	L	L	L					15 msec-30 msec	H	L	L	L
PRO. LOG PHANTOM							H	H	L	L	L	L													By PRO. LOGIC T. TONE				
WIDE							L	L	L	L	L	L																	
3CH							L	H	L	L	L	L																	
SPECTAREA							H	H	L	H	H	H													0 msec-130 msec	H	H	L	H
HALL	○						L	L	H	H	H	H																	
SIMULATED	○						L	L	H	H	H	H													Fixed to 0 msec				
LIVE	○						L	L	H	H	H	H													0 msec-130 msec				
SYNTHETIC	○						L	L	H	H	H	H																	
HI. VISION	○						L	L	H	H	H	H													0 msec-130 msec	H	L	L	L
VDP DIRECT							L	L	H	H	H	H																	
	MANUAL	AUTO	INPUT	NUM2175	Normal Phase	Reverse Phase	VDP DIRECT																	0-30 msec steps by 0.5 msec.					
	Balance	Front Sig.	Surround Out																					30-130 msec steps by 2 msec.					
	Pro. Log.	C: L+R	S: L+R	S: L+R	S: Hi Vision C																			"L": Fixed to "L". Unable to control.					

At SPECTAREA mode, AUTO, BAL changes to ON/OFF feasible.

(2) Dolby Pro-logic surround circuit

AVR-3020/AVC-2020/AVC-2020G provides **Dolby pro-logic surround circuit** surround decoder which functions same as Dolby surround decoder for professional use. The circuit is also called **active decoder**, and it comprises a different circuit from **passive decoder**, conventionally employed for home use labelled as "Dolby surround." (Figure 2)

Directional enhancer to produce crisp sound image travel.

Main feature is **Directional enhancement circuit**. The conventional Dolby surround circuit is designed to control 3 channels (L-R-S), but this circuit provides a new center channel for 4 channels (L-R-C-S) control, and employs speaker system same as that of a theater to produce the sound effect.

A merit of directional enhancement circuit greatly improves the front and rear sound separation to provide a sharp and dynamic front and rear sound image traveling. Conventionally the front and rear separation is around 3 dB, but the pro-logic provides approximately 26 ~ 40 dB. (Figure 3, 4).

The directional enhancement circuit controls left, right, center and surround signals independently, and the sound image is very crisp and clear. With the conventional Dolby surround, the center sound image is nothing but compound of L and R channels, but the pro-logic has an independent center channel to produce the sound image, and achieved approximately 26 ~ 40 dB L and R channels separation. When the sound image is at center, both L and R channel output are cut down and as the sound image travels to L channel, center and R channel output are cut to enhance the travel of the sound as it is literally a directionally enhanced design.

Feature of Pro-Logic mode

- **NORMAL:** Signals in which below 100Hz is cut are applied to center channel, and the signals below 100Hz are applied to L and R front speakers. Employ L and R speakers of a certain grade (as a pointer, use ones better than book-shelf), and use a smaller speaker for the center channel.
- **WIDE:** Normal signal is applied to center channel as it is. Employ speakers of the same grade (better than book-shelf) for center channel as well as L and R speakers.
- **PHANTOM:** Center channel signals are evenly applied to L and R channels. When a center speaker is not available, this mode is employed. Even without the center channel, the directional enhancement circuit functions as it is.
- **3CH LOGIC:** "3CH LOGIC" mode built in remote control is to enjoy the surround mode without the surround speaker. In normal pro-logic mode, rear (Sch) outputs reversed phase of Lch, Rch input, but in this mode the output is mixed with the front direction Lch and Rch outputs.
- **TEST TONE (Remote control):** Used to adjust output level of each channel.

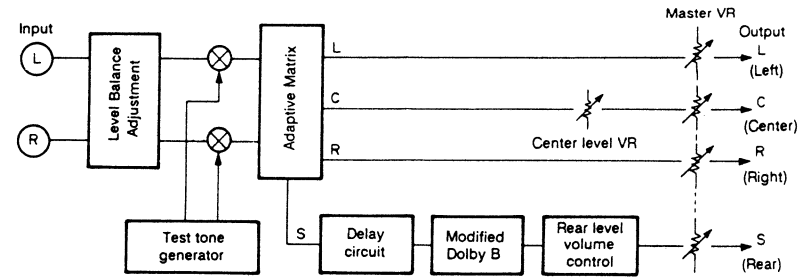

Figure 2

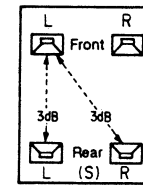

Figure 3
Dolby surround decoder
(Passive decoder)

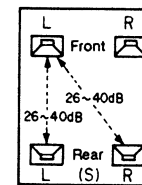

Figure 4
Dolby pro-logic surround decoder
(Active decoder)

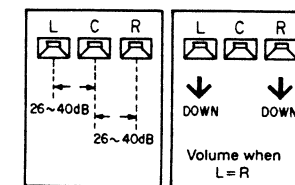

Figure 5
Dolby pro-logic surround decoder
(Active decoder)

Confirm Pro-logic circuit function

Confirm correct pro-logic circuit function with input signal shown in table below.

- **Measurement :** Apply the correct input signal, and adjust level VR of master, center and rear, so that the level falls approximately within * level, respectively.

	Input	Output	Mode		
			Normal	Phantom	Wide
Pro-logic	L ch only	L	* 0 dB (1 kHz)	→	→
		C	(a) Below -20 dB (Normally approximately -26 ~ -42 dB)		
		R			
		S			
	R ch only	L	Same as (a)		
		C			
		R	* 0 dB (1 kHz)	→	→
		S	Same as (a)		
	L = R Same Phase signal	L	Below -20 dB/approx. -6 dB	0 dB	Same as (a)
		C	* 0 dB/approx. -3 dB	Same as (a)	0 dB/0 dB
R		Below -20 dB/approx. -6 dB	0 dB	Same as (a)	
S		Same as (a)			
L = -R Both CHs Reversed Phase signal	L	Same as (a)			
	C				
	R				
	S	* +3 dB	→	→	
3 ch logic	L = -R Both CHs Reversed Phase signal	L	* -3 dB	→	→
		C	Same as (a)		
	S	R	* -3 dB	→	→
		S	Same as (a)		

* 1 kHz/100 Hz

Table 3

ADJUSTMENT



Idling Current (1U-2193-1) (1U-2196-2)

Required measurement equipment: DC Voltmeter

Arrangement

(1) Avoid direct blow from an air conditioner or an electric fan, and adjust the unit at normal room temperature 15°C ~ 30°C. (59°F ~ 86°F).



(2) Presetting

- POWER (Power source switch) → OFF ()
- VOLUME (Volume control) → 0: fully counterclockwise ( min.)
- BASS, TREBLE (Tone control) → 0: (Controls to center)
- SPEAKERS (Speaker terminal) → No load (Do not connect speaker, dummy resistor, etc.)

(3) Remove top cover and set VR201, 202 (1U-2193-1 Main PCB), VR301, 302 (1U-2196-2 Center Amp PCB) to counterclockwise end position.

Adjustment

(1) Connect DC Voltmeter to test points (Lch T.P.1, Rch T.P.2) of 1U-2193-1 (Main PCB = PCB at the lower bottom of the unit) and test points (L ch T.P.3, R ch T.P.4) of 1U-2196-2 (Center Amp PCB = PCB reversely attached to the main radiator).

(2) Connect power cord to AC line, and turn power switch "ON" (). Allow 10 minutes, and turn VR201, 202 and VR301, 302 clockwise () and adjust the TEST POINT voltage to 2.3 ± 1.0 mV DC.

(3) Allow 2 minutes, and adjust the VR201, 202 and VR301, 302 so that the meter reads 3.0 ± 1.0 mV DC.

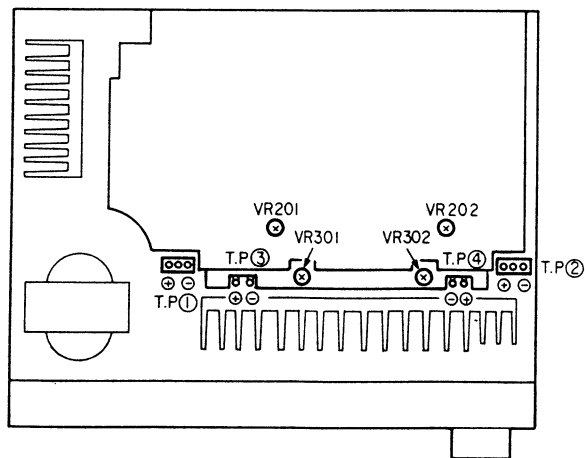

Video H SYNC· V SYNC Oscillation Frequency Adjustment

Required measurement equipment: Frequency Counter

Arrangement

Video & Microcomputer PCB (1U-2194) (Parts Side)

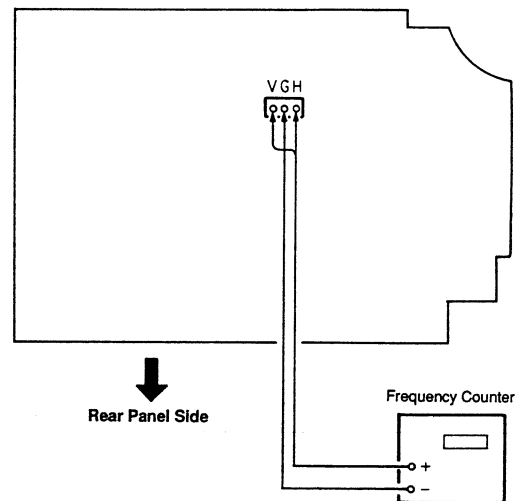

- Ground (-) side of frequency counter to G-terminal at center of the test point (T.P.) of Video and microcomputer PCB (1U-2194-1).
- Confirm that no insertion of video input or output is made. (With optional function)

(1) H SYNC (Horizontal synchronous pulse) Adjustment

- Connect probe for frequency counter to H.
- Turn VR72 with non-magnetic screwdriver and adjust the frequency counter so as to read $15.734 \text{ kHz} \pm 200 \text{ Hz}$.

(2) V SYNC (Vertical synchronous pulse Adjustment)

- Connect probe for frequency counter to V.
- Turn VR71 with non-magnetic screwdriver and adjust the frequency counter so as to read $55 \text{ Hz} \pm 1 \text{ Hz}$.

(3) Adjustment completion

- Disconnect the frequency counter.

SEMICONDUCTORS

• IC's

HD404019
(V: IC801)

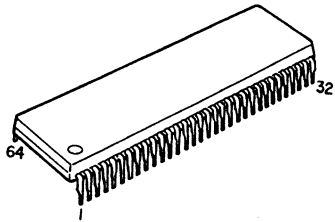

Note) Indications before IC numbers denote P.C.B. Name.

- FA : Front Amp P.C.B.
- V : Video P.C.B.
- FL : FL P.C.B.
- RA : Rear Amp P.C.B.
- V : VDP Direct P.C.B.

HD404019 Terminal Function

No.	Name	Circuitry	I/O	ACT	INT	Current	Symbol	Application
1	D11	PMOS	O	H	L	mA	SP-A	RELAY
2	D12	PMOS	O	H	L	mA	SP-B	RELAY
3	D13	PMOS	O	H	L	mA	CENTER	RELAY&PREOUT
4	D14	PMOS	O	H	L	mA	REAR	RELAY&PREOUT
5	D15	PMOS	O	H	L	mA	POWER	RELAY
6	R00	PMOS	O		L	mA	V.REC C	VIDEO Selector Multiplexer 4051 Control
7	R01	PMOS	O		L	mA	V.REC B	VIDEO Selector Multiplexer 4051 Control
8	R02	PMOS	O		L	mA	V.REC A	VIDEO Selector Multiplexer 4051 Control
9	R03	PMOS	O		L	mA	V.IN C	VIDEO Selector Multiplexer 4051 Control
10	R10	PMOS	O		L	mA	V.IN B	VIDEO Selector Multiplexer 4051 Control
11	R11	PMOS	O		L	mA	V.IN A	VIDEO Selector Multiplexer 4051 Control
12	R12	PMOS	O	H	L	mA	VCR-1	VCR REC Inhibit VCR-1
13	R13	PMOS	O	H	L	mA	VCR-2	VCR REC Inhibit VCR-2
14	R20	PMOS	O	H	L	mA	RES	OSD (M50554) FLD Driver RESET: "L"
15	R21	PMOS	O	L	L	mA	AVSE	AVSE (AVSE ON: "L")
16	R22	PMOS	O	H	L	mA	CINEMA	CINEMA C (CINEMA ON: "H")
17	R23	PMOS	O	H	L	mA	VDP-DIRECT	VDP-DIRECT (ON: "H")
18	RA0	PMOS	I	L	H	mA	PROTECT	PROTECT IN (PROTECT IN: "L")
19	RA1	PMOS	I			mA	SYNCDDET	SYNC DETECT (SYNC: ?????)
20	R30	NMOS	O		L	mA	C/R MODE1	4052 Control CENTER/REAR MODE-A
21	R31	NMOS	O		L	mA	C/R MODE2	4052 Control CENTER/REAR MODE-B
22	INT0		I	L	H		REM	Remote Control Input
23	INT1		I	L	H		POFF	Power Detect ("L" at power breakdown)

No.	Name	Circuitry	I/O	ACT	INT	Current	Symbol	Application
24	R50	NMOS	O	L	L	mA	N. ON/OFF	NOISE ON/OFF NJM2175L NOISE ON: "L"
25	R51	NMOS	O			mA	N. SEQ1	NOISE SEQ1 (A) NJM2175L
26	R52	NMOS	O			mA	N. SEQ2	NOISE SEQ2 (B) NJM2175L
27	R53	NMOS	O	H	L	mA	C. ON/OFF	CENTER ON/OFF NJM2175L CENTER ON: "H" 10
28	R60	NMOS	O	H	L	mA	C. MODE 1	(NORMAL) CENTER MODE 1 NJM2175L 15
29	R61	NMOS	O	H	L	mA	C. MODE 2	(WIDE) CENTER MODE 2 NJM2175L 15
30	R62	NMOS	O	H	L	mA	VOL UP	MOTOR VOL UP
31	R63	NMOS	O	H	L	mA	VOL DOWN	MOTOR VOL DOWN
32	Vcc						Vcc	POWER SUPPLY (+5V)
33	SCK		O	Si			FILD, OSD CLOCK	M50554 FLD CK
34	S1		O	Si			OSD ST	M50554 ST
35	S0		O	Si			FLD, OSD DATA	M50554 FLD DATA
36	R43		O	Si		mA	FLD ST	FLD ST
37	R70	NMOS	O	Si		mA	LV1000CK	TIME LINK CK
38	R71	NMOS	O	Si		mA	LV1000 SDATA	TIME LINK DATA
39	R72	NMOS	O	Si		mA	LV1000	TIME LINK SRAS
40	R73	NMOS	O	Si		mA	LV1000	TIME LINK SCAS
41	R80	NMOS	O	L	H	mA	LV1000	DELAY MUTE ("L" at MUTE MODE)
42	R81	NMOS	O	Si		mA	VOL CK	TC9176 CK
43	R82	NMOS	O	Si		mA	VOL DATA	TC9176 DATA
44	R83	NMOS	O	Si		mA	VOL ST	TC9176 ST
45	R90	NMOS	I	H	L		KR1	KEY RECEIVE 1
46	R91	NMOS	I	H	L		KR2	KEY RECEIVE 2
47	R92	NMOS	I	H	L		KR3	KEY RECEIVE 3
48	R93	NMOS	I	H	L		KR4	KEY RECEIVE 4
49	RESE						RESET	MICROCOMPUTER RESET
50	TEST						TEST	CONNECT TO Vcc
51	OSC1						OSC1	Ceramic Filter
52	OSC2						OSC2	Ceramic Filter
53	GND						GND	GND
54	D0	NMOS		H	L	mA	3CH/4CH	"H": 3CH 3CH/4CH NJM2175L
55	D1	NMOS	O		L	mA	FUNC CK	LC7821, 7822, 7823 CK
56	D2	NMOS	O	Si	L	mA	FUNC DATA	LC7821, 7822, 7823 DATA
57	D3	NMOS	O	Si	L	mA	FUNC ST	LC7821, 7822, 7823 ST
58	D4	PMOS	O	L	H	mA	LED	MASTER VOL. LED
59	D5	PMOS	O		H	mA	KS1	KEY SCAN 1
60	D6	PMOS	O		H	mA	KS2	KEY SCAN 2
61	D7	PMOS	O		H	mA	KS3	KEY SCAN 3
62	D8	PMOS	O		H	mA	KS4	KEY SCAN 4
63	D9	PMOS	O		H	mA	KS5	KEY SCAN 5
64	D10	PMOS	O	H	L	mA	HP/PRE	FRONT, MONO PRE OUT HEADPHONE

M50554-001SP (V: IC704)

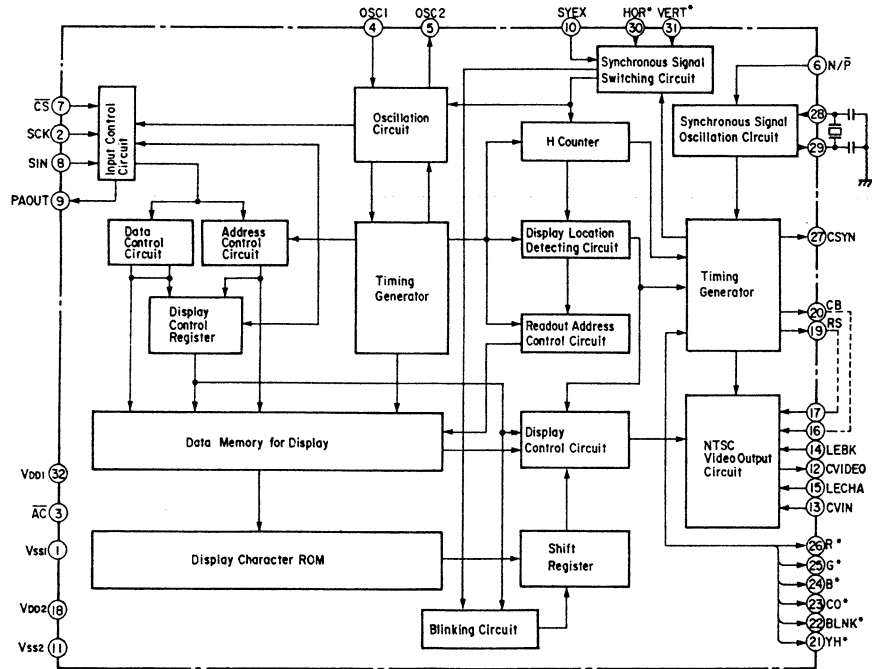
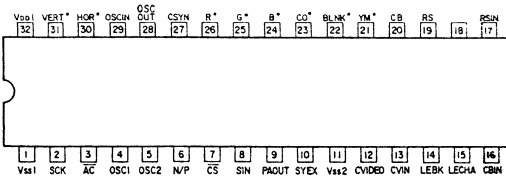
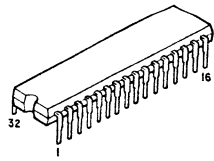

M50554-001SP Terminal Function

Pin No.	Symbol	Terminal Name	Function
1	V _{SS1}	Ground terminal	Digital ground terminal; connect to GND.
2	SCK	Serial clock input	When "L" at CS terminal, takes in SIN serial data at rise time of SCK. Hysteresis input. Built-in Pull-up resistor.
3	AC	Auto clear input	Reset IC internal circuit at "L" mode. Built-in Pull-up resistor. Hysteresis input.
4	OSC1	Oscillator circuit external terminal	External terminal for display oscillator circuit. Reference oscillation frequency is approx. 7MHz. Display position is horizontal of TV screen and character width are determined by this oscillation frequency.
5	OSC2		
6	N/P	NTSC/PAL switch input	Synchronous signal generator switch terminal of NTSC or PAL system. Generates synchronous signal of NTSC type at "H" mode, and synchronous signal of PAL type at "L" mode. Built-in Pull-up resistor.
7	CS	Chip select input	Chip select terminal; set to "L" mode for serial transfer. Built-in Pull-up resistor.
8	SIN	Serial data input	Serially inputs memory data and address for display control register and display data. Built-in Pull-up resistor.
9	PAOUT	Parity output	Odd number parity output; detects one-bit error in one word of SIN.
10	SYEX	Synchronous signal switch input	Switch terminal for external or internal synchronous signal. Enter external synchronous signal mode at "H" and internal synchronous signal mode at "L". SYEX comprises logic sum with EX register of address 243 in display control register and internal synchronization. Built-in Pull-up resistor.
11	V _{SS2}	Ground terminal	Analog ground terminal; connect to GND.
12	CVIDEO	Composite Video output	Output terminal of composite video signal. Outputs 2Vp-p composite video signal. At superimpose mode, outputs output characters, etc. superimposed on CVIN signal.
13	CVIN	Composite Video input	Input terminal of composite video signal. At superimpose mode, output characters, etc. are superimposed on this composite video signal.
14	LEBK	Blanking level	Input terminal to determine blanking level of video signal.
15	LECHA	Character level input	Input terminal to determine character output level of video signal.
16	CBIN	Color burst signal input	Input CB output after converting to color burst signal level of video signal, via external circuit.
17	RSIN	Character background carrier color signal input	Input RS output after converting to carrier color signal level of video signal, via external circuit.
18	V _{DD2}	Power supply terminal	Analog power supply terminal; connect to +5V.
19	RS	Character background carrier color signal output	Carrier color signal output for coloring character background. Outputs signal with phase angle to color burst signal CB. Amplitude 5V.
20	CB	Color burst signal output	Outputs color burst signal of 3.58MHz for NTSC system, 4.43MHz for PAL system. Amplitude 5V.
21	YH	Brightness signal output	Brightness signal output; able to select polarity at character ROM determination.
22	BLNK	Character background output	Outputs character background signal; able to select polarity at character ROM determination.
23	CO	Character output	Outputs character signal; able to select polarity at character ROM determination.
24	B	Blue color output	Blue color output; able to select polarity at character ROM determination.
25	G	Green color output	Green color output; able to select polarity at character ROM determination.
26	R	Red color output	Red color output; able to select polarity at character ROM determination.
27	CSYN	Composite synchronous signal output	Outputs composite synchronous signal of NTSC or PAL system. Negative polarity. Amplitude 5V.
28	OSCOUT	Synchronous signal generating oscillator circuit	External terminal of synchronous signal generating oscillator circuit. For NTSC system, oscillation frequency of 14.32MHz, and for PAL system, of 17.73MHz are used.
29			
30	HOR	Horizontal synchronous signal's signal	Inputs horizontal synchronous signal. Hysteresis input. Able to select polarity at character ROM determination.
31	VERT	Vertical synchronous signal's signal	Inputs vertical synchronous signal. Hysteresis input. Able to select polarity at character ROM determination.
32	V _{DD1}	Power supply terminal	Digital power supply terminal; connect to +5V.

LA7820 (V: IC705)

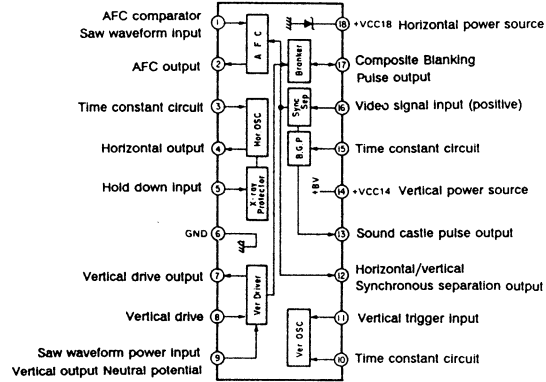
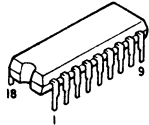

μPC1225H (RA: IC301-304)

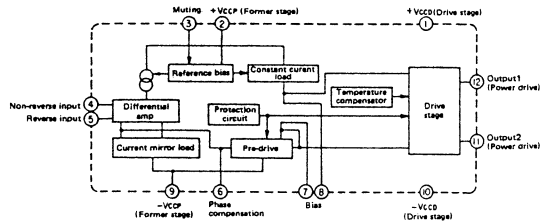
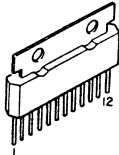

NJM2220S (V: IC711)

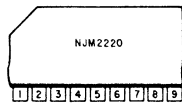
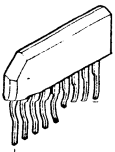

1. M.M time constant setting
2. SYNC input (Comp. H.V. SYNC)
3. SYNC output
4. SSG SYNC input
5. GND
6. SYNC DET Determine/Control
7. SYNC DET
8. M.M Smoother
9. V + 5 ~ 10V

TC4051BP
TC4052BP

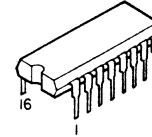

TC4051BP
(V: IC701, 702, 706, 707, 709, 710)

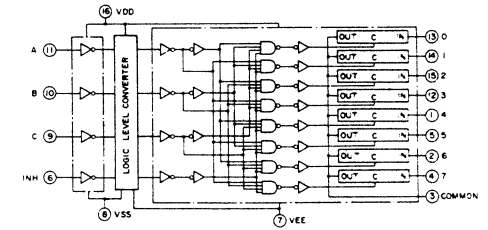
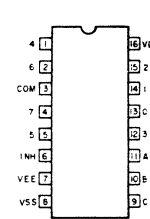

TC4052BP
(RA: IC541)

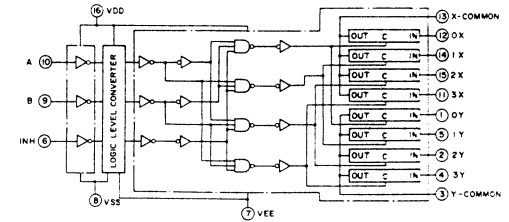
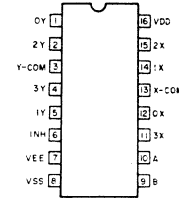

HD14066BP (V: IC703, 708)

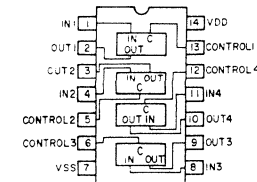
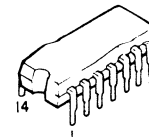

LC7821 (FA: IC102, 104)
 LC7822 (FA: IC103)
 LC7823 (RA: IC534)

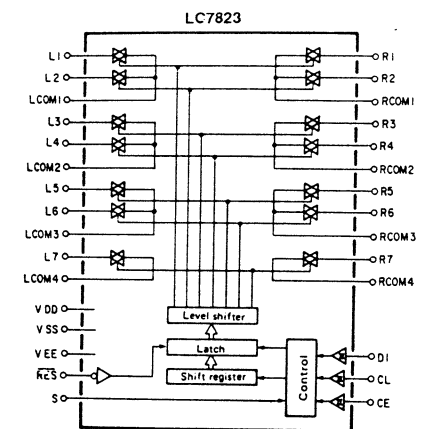
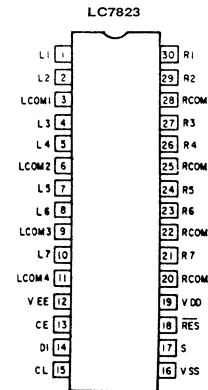
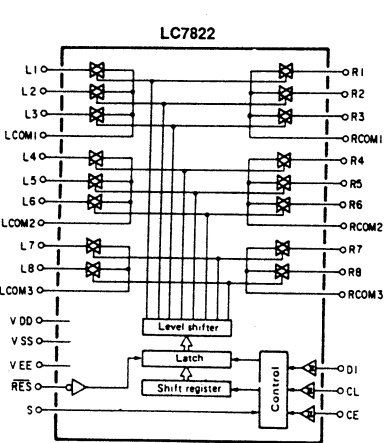
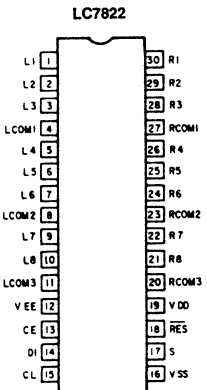
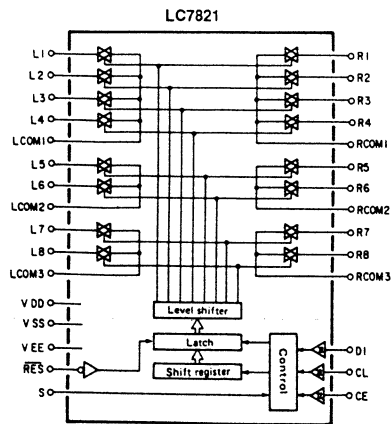
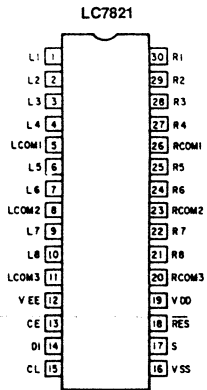
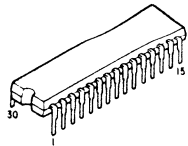
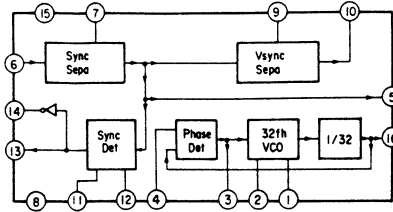
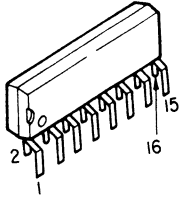

Table of LC7821, LC7822, LC7823 Terminal Function

Name of Terminal	I/O	Equivalent Internal Circuit	Function of Terminal																																											
V _{DD} , V _{SS} , V _{EE}			Power terminal.																																											
L1 - L8, R1 - R8, LCOM1 - LCOM4, BCOM1 - BCOM4		Refer to block diagram	In/Out terminal of analog switch.																																											
CL, DI, CE	I		Serial data input terminal (Schmitt buffer). CL = Clock input terminal. DI = Data input terminal. CE = Chip enable terminal.																																											
S	I		Selection terminal for using of two. Address will be shifted as per below table when switching S terminal to L or H. <table border="1" style="margin: 10px auto;"> <thead> <tr> <th rowspan="2">Name of Item</th> <th rowspan="2">S Terminal</th> <th colspan="4">Address</th> </tr> <tr> <th>A0</th> <th>A1</th> <th>A2</th> <th>A3</th> </tr> </thead> <tbody> <tr> <td rowspan="2">LC7821</td> <td>L</td> <td>0</td> <td>1</td> <td>0</td> <td>1</td> </tr> <tr> <td>H</td> <td>1</td> <td>1</td> <td>0</td> <td>1</td> </tr> <tr> <td rowspan="2">LC7822</td> <td>L</td> <td>0</td> <td>0</td> <td>1</td> <td>1</td> </tr> <tr> <td>H</td> <td>1</td> <td>0</td> <td>1</td> <td>1</td> </tr> <tr> <td rowspan="2">LC7823</td> <td>L</td> <td>0</td> <td>1</td> <td>1</td> <td>1</td> </tr> <tr> <td>H</td> <td>1</td> <td>1</td> <td>1</td> <td>1</td> </tr> </tbody> </table>	Name of Item	S Terminal	Address				A0	A1	A2	A3	LC7821	L	0	1	0	1	H	1	1	0	1	LC7822	L	0	0	1	1	H	1	0	1	1	LC7823	L	0	1	1	1	H	1	1	1	1
Name of Item	S Terminal	Address																																												
		A0	A1	A2	A3																																									
LC7821	L	0	1	0	1																																									
	H	1	1	0	1																																									
LC7822	L	0	0	1	1																																									
	H	1	0	1	1																																									
LC7823	L	0	1	1	1																																									
	H	1	1	1	1																																									
RES	I		Reset terminal. Condition of analog switch is not fixed at the time of turning on the power. When shift this terminal to L, all analog switches become OFF.																																											

NJM220S (V: IC711)



TC9176P (RA: IC544)

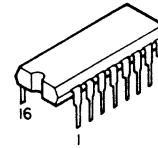

BA6109 (V: IC901)

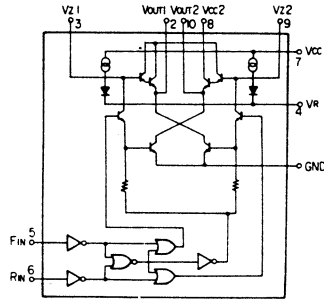
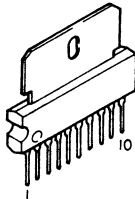

M51594A (V: IC802)

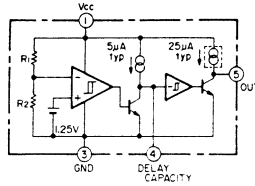
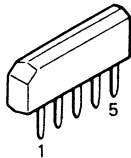

M5218AP
(FA: IC105, 501)
(RA: IC531, 532, 550, 920, 542, 546, 547, 543, 181)
(V: IC981)

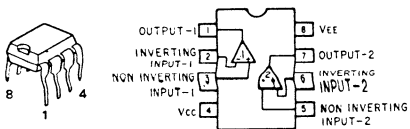

NJM4556D (FA: IC513)
NJM4558D-D (FA: IC101)
OP271 (RA: IC546)

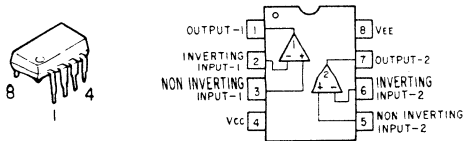

NJM7806FA (V: IC905, 915)
NJM7815FA (V: IC902, 903)

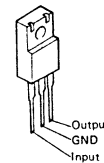

NJM7906FA (V: IC906)
NJM7915FA (V: IC904)

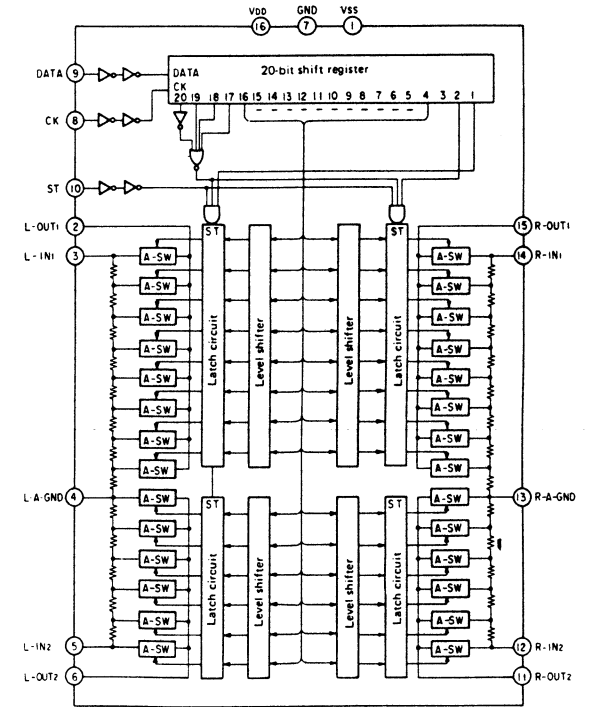
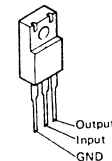

MSC7128-03SS (FL: IC917)

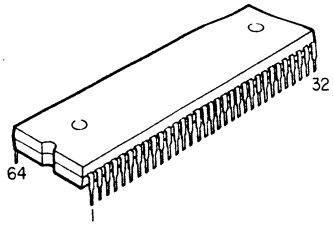

OSCO	1	64	CS
OSCI	2	63	DA
TEST COUNT	3	62	CP
TEST STEP	4	61	RESET
VSS	5	60	VDD1
VEE	6	59	VDD2
COM1	7	58	SEG1
COM2	8	57	SEG2
COM3	9	56	SEG3
COM4	10	55	SEG4
COM5	11	54	SEG5
COM6	12	53	SEG6
COM7	13	52	SEG7
COM8	14	51	SEG8
COM9	15	50	SEG9
COM10	16	49	SEG10
COM11	17	48	SEG11
COM12	18	47	SEG12
COM13	19	46	SEG13
COM14	20	45	SEG14
COM15	21	44	SEG15
COM16	22	43	SEG16
SEG36	23	42	SEG17
SEG35	24	41	SEG18
SEG34	25	40	SEG19
SEG33	26	39	SEG20
SEG32	27	38	SEG21
SEG31	28	37	SEG22
SEG30	29	36	SEG23
SEG29	30	35	SEG24
SEG28	31	34	SEG25
SEG27	32	33	SEG26

MSC7128-03SS Terminal Function

Terminal Name	Terminal No.	I/O	Connection to:	Function
V _{DD1}	60		Power supply	V _{DD1} —V _{SS} Internal logic power supply. V _{DD2} —V _{EE} Fluorescent display tube drive circuit power supply.
V _{DD2}	59			
V _{SS}	5			
V _{EE}	6			
DA	63	I	Microcomputer	Serial data input. Input from(Positive logic) LBS.
CP	62	I	Microcomputer	Shift clock input. Data shift at rise time of CP.
CS	64	I	Microcomputer	Chip select input. Serial transfer of data is prohibited when set to "Hi".
OSCI	2	I		External terminal of CR for CR oscillation. fosc = 250KHz at C= 100PF, R= 47KΩ.
OSCO	1	O		
RESET	61	I		Reset input (Built-in Pull-up resistor). Internal logic is reset when "LOW" is set, and output of SEG1-36, COM1-16 all become "LOW".
COM1 - COM16	7 - 22	O	Fluorescent display tube grid	Drive output of fluorescent display tube grid. Able to connect directly to fluorescent display tube, and no Pull-down resistor is needed. I _{OH} —30mA.
SEG1 - SEG35	58 - 24	O	Fluorescent display tube anode	Drive output of anode for fluorescent display tube 5x7 dot. Able to connect directly to fluorescent display tube and no Pull-down resistor is needed. I _{OH} —2mA.
SEG36	23	O	Fluorescent display tube anode	Drive output of anode for fluorescent display tube casole. Able to connect display to fluorescent display tube and no Pull-down resistor is needed. I _{OH} —10mA.
TEST STEP	4	I		Test mode setting input (Normally opened).
TEST COUNT	3	I		Test clock input (Normally opened).

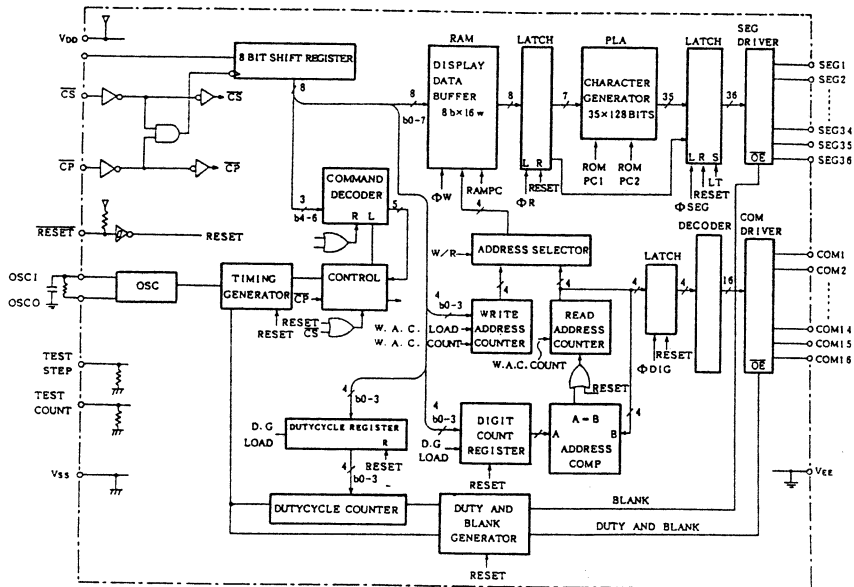

SSM-2125D (RA: IC551)

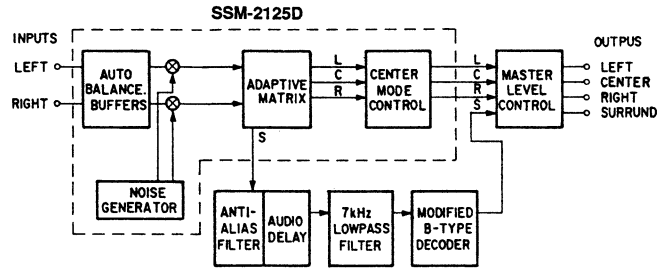
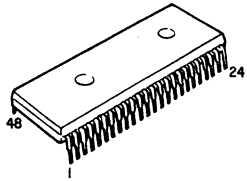

LV1000 (RA: IC539)

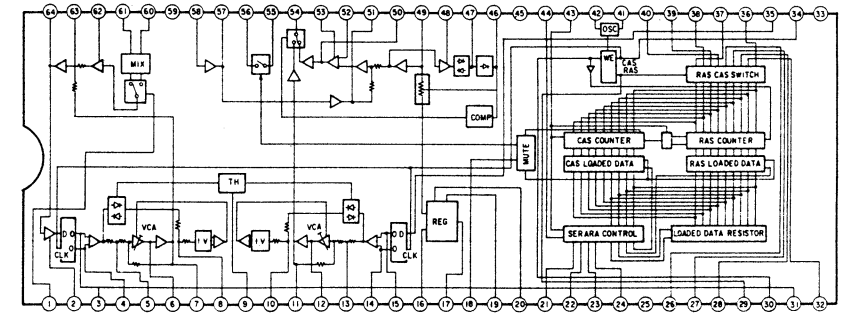
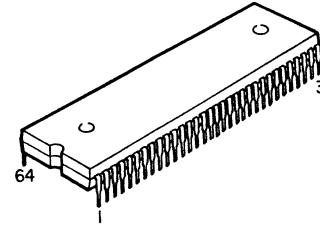

LM33256N-15 (RA: IC540)

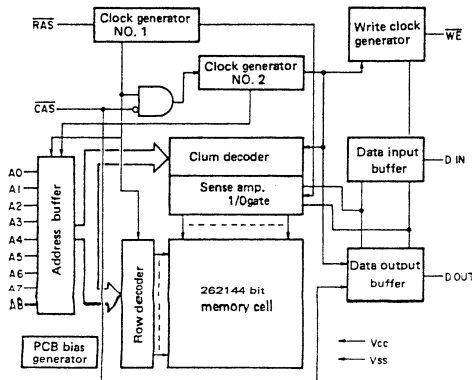
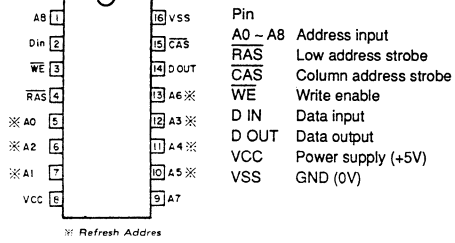
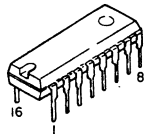

• TRANSISTORS

2SA970 (BL)
2SA988 (E/F)
2SC1815 (Y)
2SC1841 (E/F)
2SC2878 (A/B)

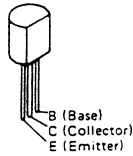

2SD667A (C)

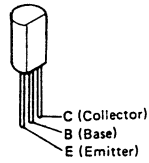

2SB1328 (P)
2SD2004 (P)

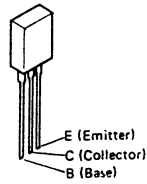

2SA1490LB3 (O/P/Y) (Z)
2SA1490 (O/P/Y) (Z)
2SA1492 (O/P/Y) (Y)
2SC3854 (O/P/Y) (Z)
2SC3854LB3 (O/P/Y) (Z)
2SC3856 (O/P/Y) (Y) (Z)

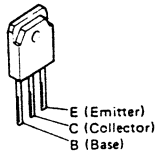

2SA1048 (GR)
2SC2458 (Y/GR) (BL)

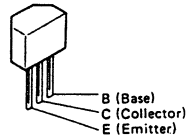

2SK184 (GR)

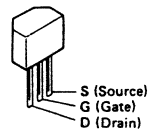

RN1202
RN1241 (A/B)
RN2202

RN1202

RN2202

RN1241 (A/B)

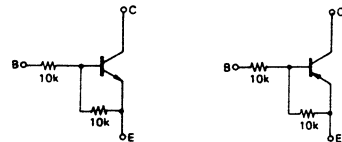
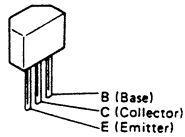

	R1	R2
RN1202	10 kΩ	10 kΩ

	R1	R2
RN2202	10 kΩ	10 kΩ

• IC PROTECTORS

ICP-N15T (V: IC99, 910, 916)
ICP-N20T (V: IC907, 908)

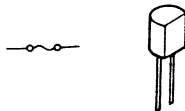

• DIODES (included LED)

1SS270A
1S2076A

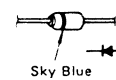

HZS4B-2
HZS5C-2
HZS7B-3
HZS7C-2
HZS9A-2
HZS9C-3
HZS12B-2
HZS15-3
HZS20-1
HZS20-1



1SR35-200

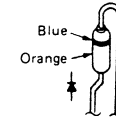

DSM1D2 (Type 3)

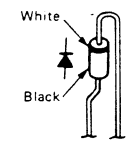

SFOR1A42 (Thyristor)

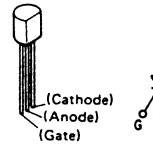

4D4B42

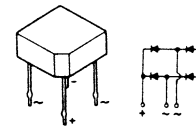

D5FB20 (4001)

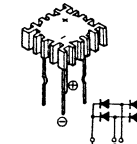

SEL2210R (Red)

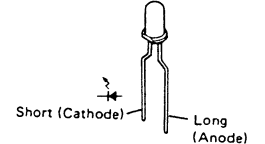

• FL DISPLAY

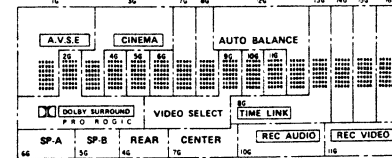
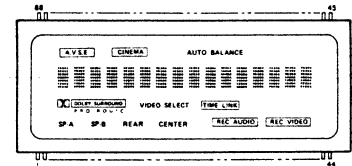

TERMINAL CONNECTION

TERMINAL No. ELECTRODE	88	87	86	85	84	83	82	81	80	79	78	77								
F1	NP	NP	NP	NP	NP	NP	NP	NP	P	P	P	P								
									(11)	(21)	(31)	(41)								
TERMINAL No. ELECTRODE	76	75	74	73	72	71	70	69	68	67	66	65	64	63	62	61	60	59	58	57
	P	P	P	P	P	P	P	P	P	NP	NP	NP	NP	P	P	P	P	P	P	P
	(81)	(12)	(22)	(32)	(42)	(52)	(13)	(23)	(33)	(43)	(53)	(63)	(73)	(83)	(93)	(103)	(113)	(123)	(133)	(143)
TERMINAL No. ELECTRODE	56	55	54	53	52	51	50	49	48	47	46	45								
	P	P	P	P	P	NP	NP	NP	NP	NP	NP	F2								
	(24)	(14)	(23)	(43)																

(LOWER)

TERMINAL No. ELECTRODE	33	34	35	36	37	38	39	40	41	42	43	44								
	P	P	P	P	NP	NP	NP	NP	NP	NP	NP	F2								
	(27)	(37)	(47)	(57)																
TERMINAL No. ELECTRODE	13	14	15	16	17	18	19	20	21	22	23	24	25	26	27	28	29	30	31	32
	3G	7G	8G	12G	13G	14G	15G	16G	11G	10G	2G	9G	NP	P	P	P	P	P	P	P
														(2)	(16)	(26)	(36)	(46)	(56)	(17)
TERMINAL No. ELECTRODE	1	2	3	4	5	6	7	8	9	10	11	12								
	F1	F1	NP	NP	NP	NP	NP	NP	NP	NP	NP	1G								

Notes: F: Filament NP: No Pin
G: Gird P: Anode

• OTHERS

SBX1610-52 (Remote Control Receiver)

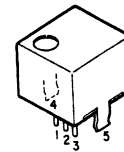

1. Vcc
2. Output
3. GND
4. Case fin
5. Case fin

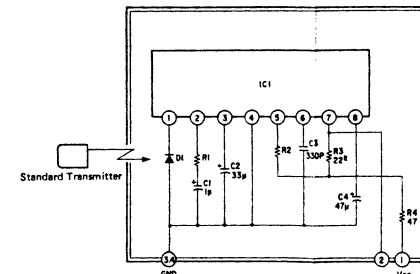

- IC1: CX20106A chip
- D1: Pin photodiode chip
- C1, C2, C4: Aluminium electrolytic capacitor
- C3: SL characteristic ± 5%
- R1: Gain control resistor
- R2: fo control resistor (using ± 1%)
- R (Other than above items): ± 5%

PRINTED WIRING BOARD (Pattern side)

1

2

3

4

5

6

7

8

1U-2193 FRONT AMP. UNIT ASS'Y

A

B

C

D

E

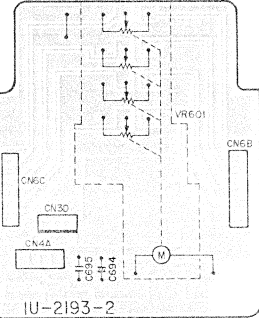
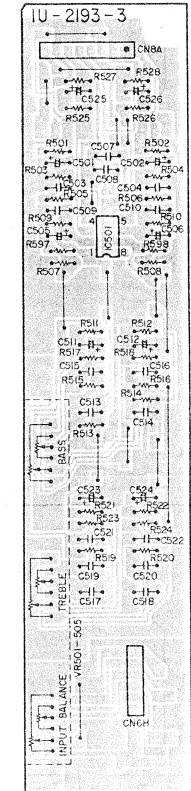
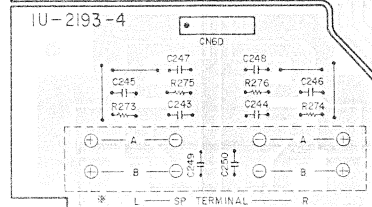
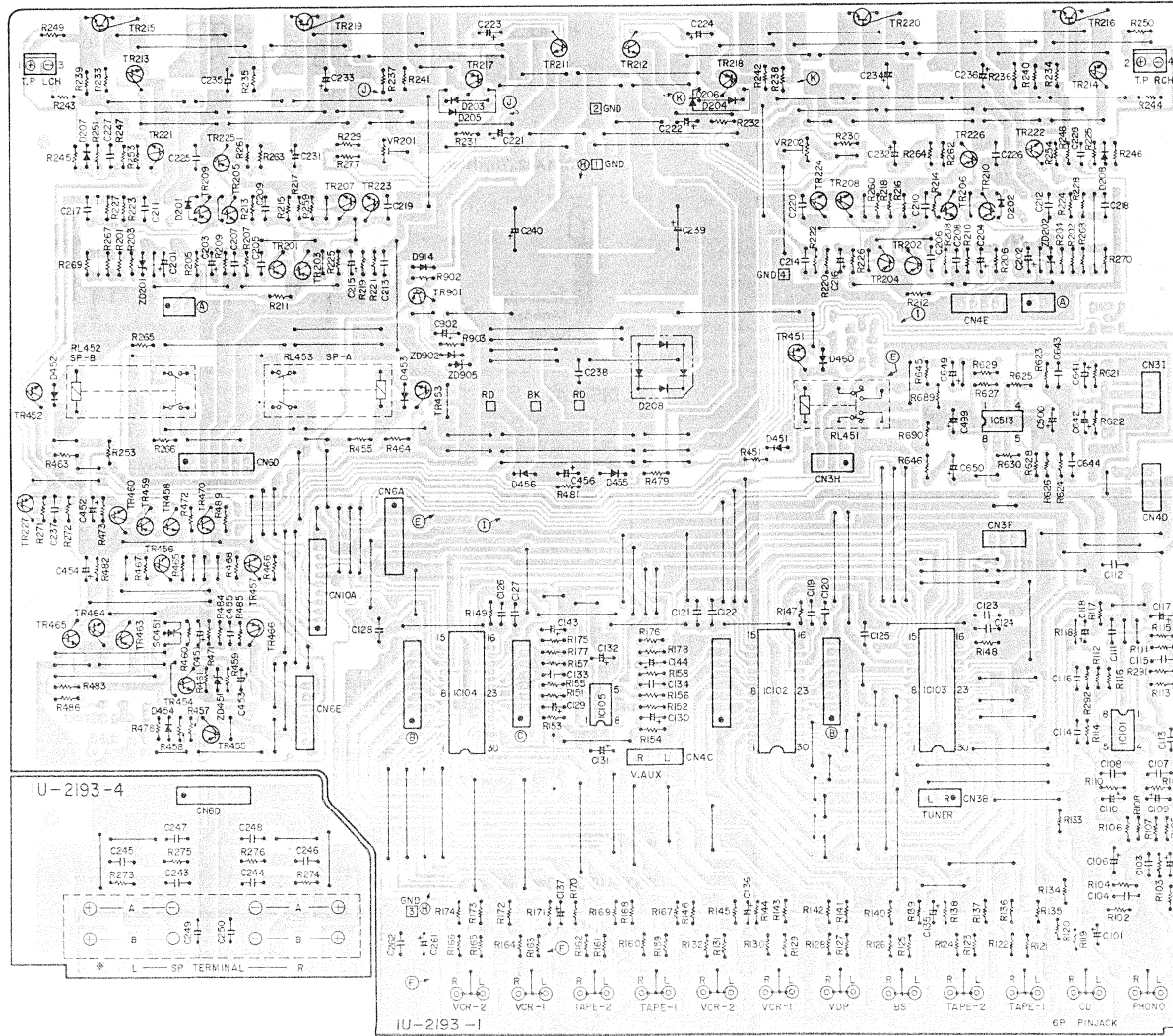

	UNIT No.	6P SP Terminal
U.S.A. & Canada	1U-2193B	205 0632 002
Multi-Voltage	1U-2193	205 0472 013

1U-2194 VIDEO UNIT ASS'Y

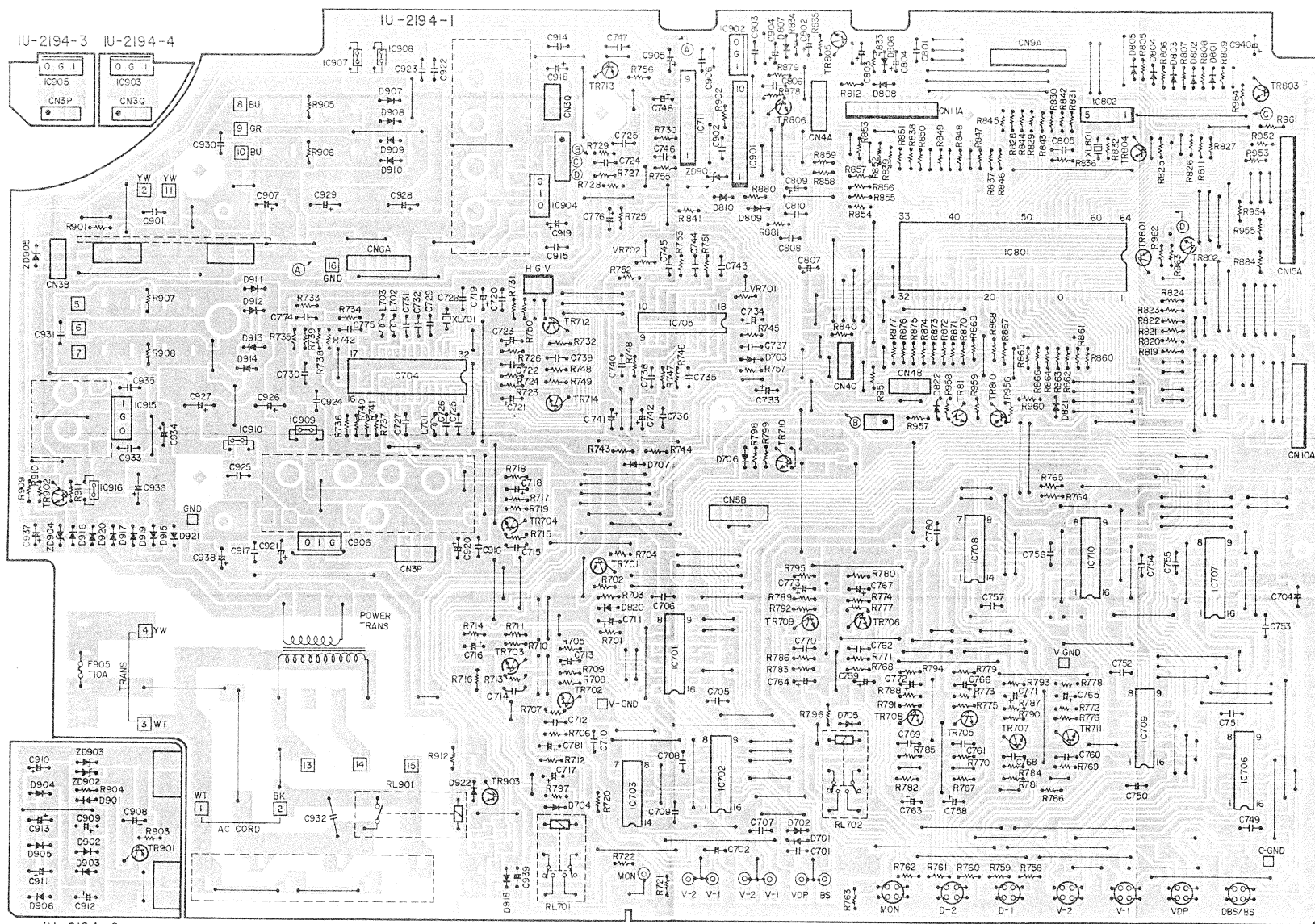

	UNIT No.	F901, 902	F905	F906	L702, 703
U.S.A. & Canada	1U-2194B	2.5A	8A	—	—
Multi-Voltage	1U-2194	—	8A	4A	27 μH

1 2 3 4 5 6 7 8

1U-2195 FL UNIT ASS'Y

A

IU-2195-6

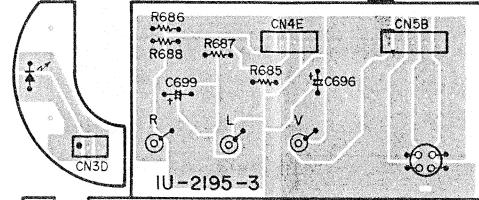

IU-2195-2

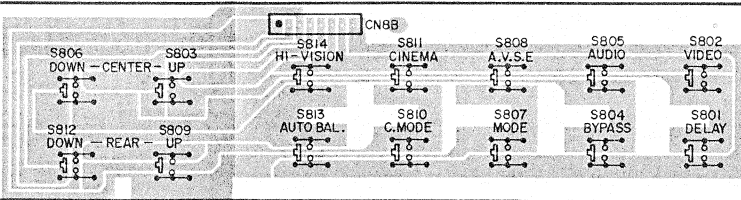

IU-2195-5

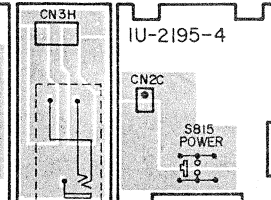

B

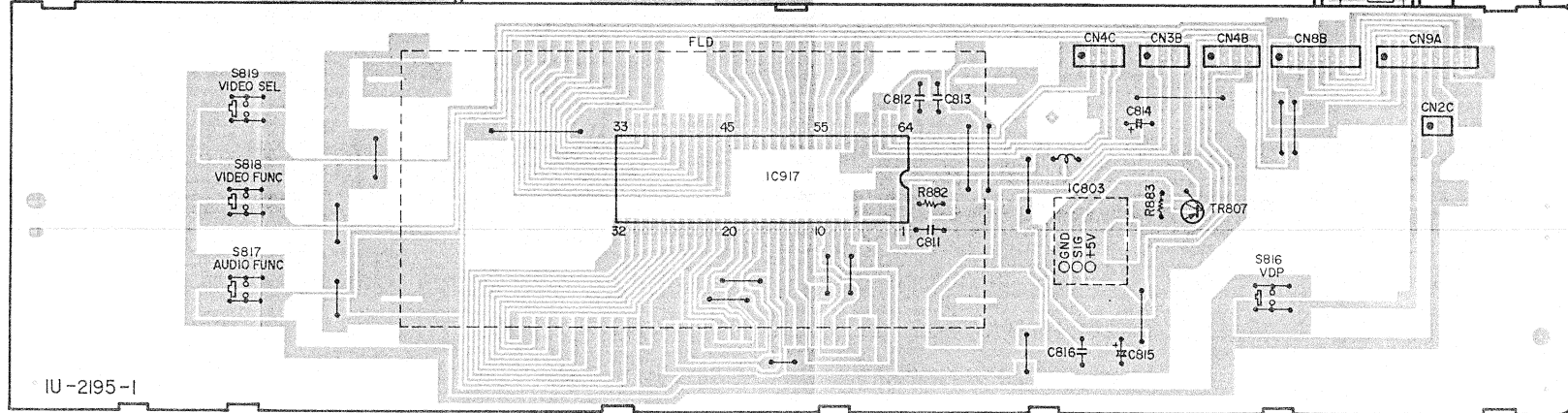

C

D

E

1 2 3 4 5 6 7 8

1U-2196 REAR AMP UNIT ASS'Y

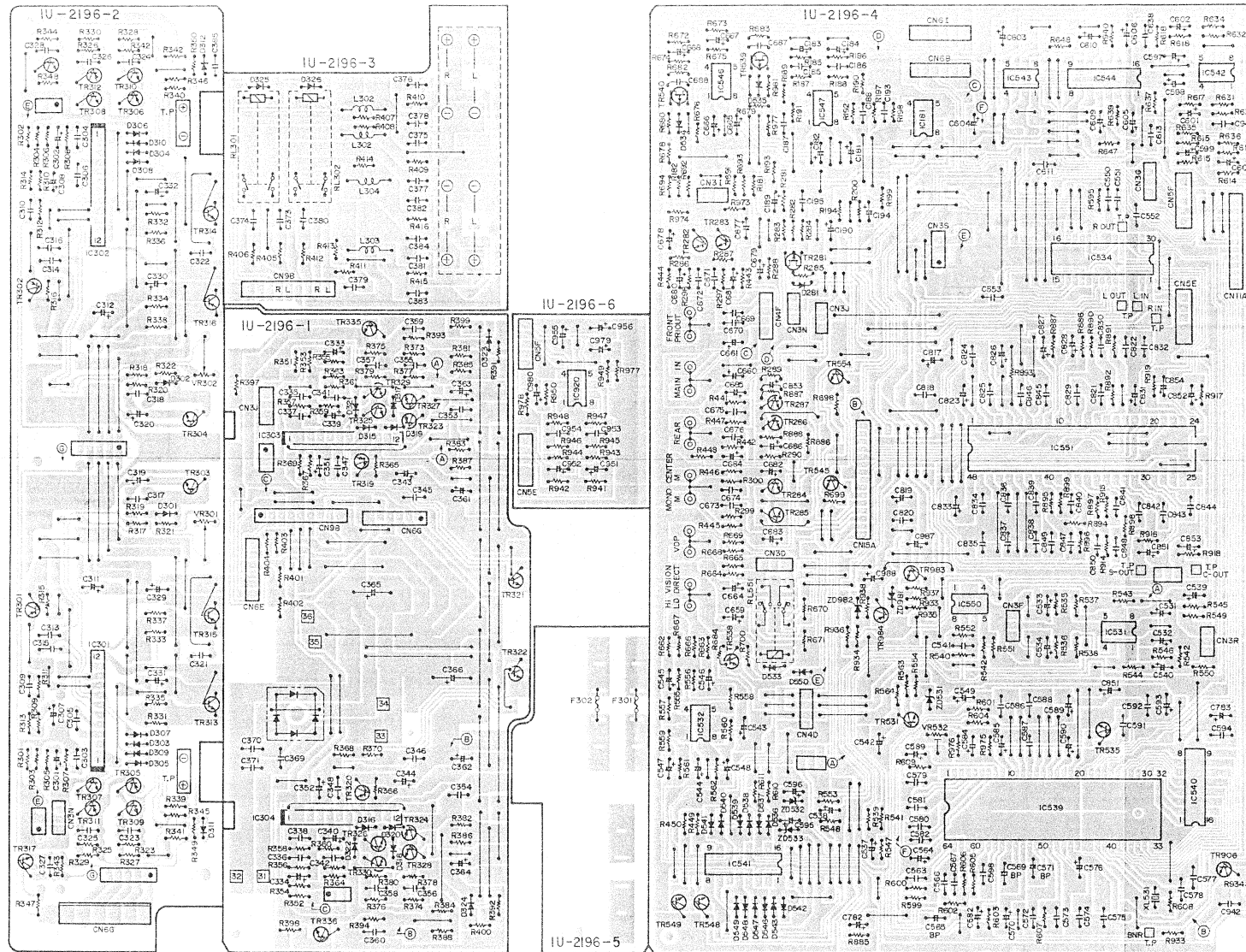

	UNIT No	R893	F301, 302	Fuse Holder	SP Terminal
U.S.A. & Canada	1U-2196B	10 MΩ	10A	4	205 0632 002
Multi-Voltage	1U-2196	—	—	—	205 0472 013

A
B
C
D
E

1U-2234 VDP DIRECT UNIT ASS'Y

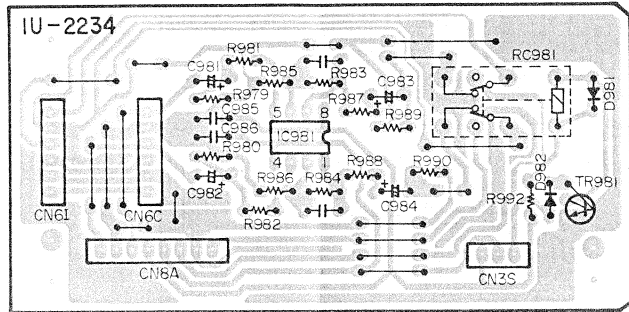

NOTE ON PARTS LIST

- Part indicated with the mark * ◎ * are not always in stock and possibly to take a long period of time for supplying, or in some case supplying of part may be refused.
- When ordering of part, clearly indicate "1" and "1" (i) to avoid mis-supplying.
- Ordering part without stating its part number can not be supplied.
- Part indicated with the mark *★* is not illustrated in the exploded view.

WARNING:

Parts marked with this symbol ⚠ have critical characteristics.
Use ONLY replacement parts recommended by the manufacturer.

● Resistors

Ex.: RN	14K	2E	1B2	G	FR
Type	Shape and performance	Power	Resistance	Allowable error	Others
RD	Carbon	2B	1W	F ±1%	P
RC	Fixed	2E	1W	G ±2%	NL
RS	Metallic film	2H	1W	J ±5%	NB
RW	Winding	3A	1W	K ±10%	FR
RN	Metal film	3D	2W	M ±20%	F
RK	Metal mixture	3F	3W		
		3H	5W		

Resistance
 1 8 2 ⇨ 1800Ω = 1.8kΩ
 T ————— indicates number of zeros after effective number
 ————— 2-digit effective number, decimal point indicated by R.
 • Units: Ω

● Capacitors

Ex.: CE	04W	1H	2R2	M	BP
Type	Shape and performance	Dielectric strength	Capacity	Allowable error	Others
CE	Aluminum foil electrolyte	0J	6.3V	F ±1%	HS
CA	Aluminum solid electrolyte	1A	10V	G ±2%	BP
CS	Tantalum electrolyte	1C	16V	J ±5%	HR
CG	Film	1E	25V	K ±10%	DL
CK	Ceramic	1V	35V	M ±20%	HF
CC	Ceramic	1H	50V	Z ±80%	U
CP	Oil	2A	100V		C
CM	Mica	2B	125V	P ±100%	W
CF	Metalized	2C	150V		F
CH	Metalized	2D	200V	C ±0.25pF	
		2E	250V	D ±0.5pF	
		2H	500V		
		2J	6.30V		

Capacity
 2 R 2 ⇨ 2.2 μF
 T ————— 1-digit effective number, decimal point indicated by R.
 ————— 2-digit effective number, decimal point indicated by R.
 • Units: μF, (for P, pF (p μF))
 • When the dielectric strength is indicated in AC, "AC" is included after the dielectric strength value.

PRINTED WIRING BOARD PARTS LIST
1U-2193B FRONT AMP UNIT ASS'Y

Ref. No.	Part No.	Part Name	Remarks	Ref. No.	Part No.	Part Name	Remarks
SEMICONDUCTORS							
IC101	265 0030 004	IC NJM4558D-D		† R257,258	244 2043 937	Metal Oxide 10Ω, 1W (N.B)	RS14B3A100JS(S)
IC102	262 1227 008	IC LC7821		† R259,260	241 2315 967	Carbon Film 68Ω, 1/4W (Fusible)	RD14B2E680GFR
IC103	262 1228 007	IC LC7822		† R261,262	241 2387 940	Carbon Film 4.7Ω, 1/4W (N.B)	RD14B2E4R7JNBS
IC104	262 1227 008	IC LC7821		† R263,264	241 2379 903	Carbon Film 470Ω, 1/4W (N.B)	RD14B2E471JNBS
IC105	263 0711 000	IC M5218AP		† R273-276	244 2043 937	Metal Oxide 10Ω, 1W (N.B)	RS14B3A100JS(S)
IC501	263 0711 000	IC M5218AP		† R425,426	241 2378 904	Carbon Film 180Ω, 1/4W (N.B)	RD14B2E181JNBS
IC513	263 0198 005	IC NJM4556D		† R451	241 2379 945	Carbon Film 680Ω, 1/4W (N.B)	RD14B2E681JNBS
TR201-204	271 0094 919	Transistor 2SA970(BL)		† R452	241 2380 905	Carbon Film 1.2KΩ, 1/4W (N.B)	RD14B2E122JNBS
TR205-208	273 0235 923	Transistor 2SC1841(E/F)		† R453	241 2378 904	Carbon Film 180Ω, 1/4W (N.B)	RD14B2E181JNBS
TR209,210	271 0131 924	Transistor 2SA988(E/F)		† R454	241 2378 962	Carbon Film 330Ω, 1/4W (N.B)	RD14B2E331JNBS
TR211,212	273 0198 905	Transistor 2SC1815(Y)		† R455	241 2378 904	Carbon Film 180Ω, 1/4W (N.B)	RD14B2E181JNBS
TR213,214	274 0151 903	Transistor 2SD2004(F)		† R456	241 2378 962	Carbon Film 330Ω, 1/4W (N.B)	RD14B2E331JNBS
TR217,218	272 0107 003	Transistor 2SB1329(F)		† R467,468	241 2378 962	Carbon Film 330Ω, 1/4W (N.B)	RD14B2E331JNBS
TR221-224	273 0235 923	Transistor 2SC1841(E/F)		† R645,646	244 2051 961	Metal Oxide 100Ω, 1W (N.B)	RS14B3A101JS(S)
TR225-227	271 0131 924	Transistor 2SA988(E/F)		† R902	241 2379 903	Carbon Film 470Ω, 1/4W (N.B)	RD14B2E471JNBS
TR451-454	273 0317 906	Transistor 2SC2458(BL)					
TR455	271 0191 906	Transistor 2SA1048(GR)					
TR456-458	273 0317 906	Transistor 2SC2458(BL)					
TR459	271 0191 906	Transistor 2SA1048(GR)					
TR460	273 0317 906	Transistor 2SC2458(BL)					
TR462	273 0317 906	Transistor 2SC2458(BL)					
TR463	271 0191 906	Transistor 2SA1048(GR)					
TR464,465	273 0317 906	Transistor 2SC2458(BL)					
TR466	271 0102 924	Transistor 2SA1015(GR)					
TR469	273 0317 906	Transistor 2SC2458(BL)					
TR471	271 0131 924	Transistor 2SA988(E/F)					
TR901	271 0131 924	Transistor 2SA988(E/F)					
D201-206	276 0049 914	Diode 1S2076A					
D207,208	276 0432 903	Diode 1SS270A					
D208	276 0424 005	Diode 4D4B42(LC1)					
D451-454	276 0432 903	Diode 1SS270A					
D914	276 0432 903	Diode 1SS270A					
ZD201,202	276 0476 927	Zener Diode HZS15-3	15V				
ZD451,452	276 0465 925	Zener Diode HZS7B-3	7V				
ZD902	276 0479 908	Zener Diode HZS20-1	20V				
ZD905	276 0479 924	Zener Diode HZS20-3	20V				
SC451	279 0016 904	Thyristor SFOR1A42					
RESISTORS (not included Carbon Film ±5%, 1/4W Type. Refer to the Schematic Diagram for those parts.)							
† R215-218	241 2380 963	Carbon Film 2.2KΩ, 1/4W (N.B)	RD14B2E22JNBS				
† R223,224	241 2377 976	Carbon Film 130Ω, 1/4W (N.B)	RD14B2E131JNBS				
† R227,228	241 2377 976	Carbon Film 130Ω, 1/4W (N.B)	RD14B2E131JNBS				
† R233,234	244 2043 982	Metal Oxide 0.22Ω, 1W (N.B)	RS14B3AR22JS(S)				
† R235,236	241 2378 920	Carbon Film 220Ω, 1/4W (N.B)	RD14B2E221JNBS				
† R237-242	244 2043 982	Metal Oxide 0.22Ω, 1W (N.B)	RS14B3AR22JS(S)				
† R245-248	241 2380 950	Carbon Film 2KΩ, 1/4W (N.B)	RD14B2E202JNBS				
Other Resistor							
VR201,202	211 6064 048	Semifixed Resistor 5KΩ	V06PB502				
VR601	211 0686 008	Variable Resistor 100KΩ	Master Volume				
	211 0687 007	Variable Resistor	3 Gang Volume				
CAPACITORS							
C101	254 4260 045	Electrolytic 1μF/50V	CE04W1H010M				
C103,104	253 3634 006	Ceramic 200pF/50V	CC45SL1H201J				
C105,106	254 4254 006	Electrolytic 10μF/16V	CE04W1C100M				
C107,108	253 1179 084	Ceramic 470pF/50V	CK45B1H47K D=3				
C109,110	254 4250 039	Electrolytic 220μF/6.3V	CE04W0J221M				
C111,112	253 1181 014	Ceramic 0.022μF/50V	CK45F1H223Z D=3				
C113,114	255 4199 999	Plastic Film 0.024μF/50V	CQ92M1H243J (MRZ)				
C115,116	255 1121 009	Plastic Film 0.0068μF/50V	CQ93M1H682J				
C117,118	254 4260 058	Electrolytic 2.2μF/50V	CE04W1H2R2M				
C119-121	253 1181 014	Ceramic 0.022μF/50V	CK45F1H223Z D=3				
C122	253 9030 028	Ceramic 2200pF/25V	CK45-1E222K				
C123-128	253 1181 014	Ceramic 0.022μF/50V	CK45F1H223Z D=3				
C129-132	254 4260 045	Electrolytic 1μF/50V	CE04W1H010M				
C133,134	253 1179 000	Ceramic 100pF/50V	CK45B1H101K D=3				
C135-137	254 4260 045	Electrolytic 1μF/50V	CE04W1H010M				
C138-140	253 1181 014	Ceramic 0.022μF/50V	CK45F1H223Z D=3				
C201,202	254 4260 090	Electrolytic 22μF/50V	CE04W1H220M				
C203,204	254 4254 035	Electrolytic 10μF/16V	CE04W1C100M				
C205,206	253 1179 042	Ceramic 220pF/50V	CK45B1H221K D=3				
C207,208	253 1179 000	Ceramic 100pF/50V	CK45B1H101K D=3				

1U-2234 VDP UNIT ASS'Y

Ref. No.	Part No.	Part Name	Remarks
SEMICONDUCTORS			
IC981	263 0711 000	IC M5218AP	
TR981	269 0025 901	Transistor RN1202(10K-10K)	Built-in Resistor
D982	276 0432 903	Diode 1SS270A	
RESISTORS (not included Carbon Film ±5%, 1/4W Type. Refer to the Schematic Diagram for those parts.)			
R992	241 2378 933	Carbon Film 240Ω,1/4W (N.B)	RD14B2E241JNBS
CAPACITORS			
C981-984	254 4254 006	Electrolytic 10μF/16V	CE04W1C100M
C985,986	253 1181 014	Ceramic 0.022μF/50V	CK45F1H223Z D=3
E.U. PARTS			
RL981	214 0127 003	Relay (RY-12W)	1
OTHER PARTS			
		P/W Board	(1)
CN3S	205 0233 032	3P EH Conn. Base	1
CN6C	205 0233 061	6P EH Conn. Base	1
CN6I	205 0277 069	6P EH Conn. Base (RD)	1
CN8A	205 0233 087	8P EH Conn. Base	1
CN3S	203 4652 040	3P EH Conn. Cord	1

BLOCK DIAGRAM

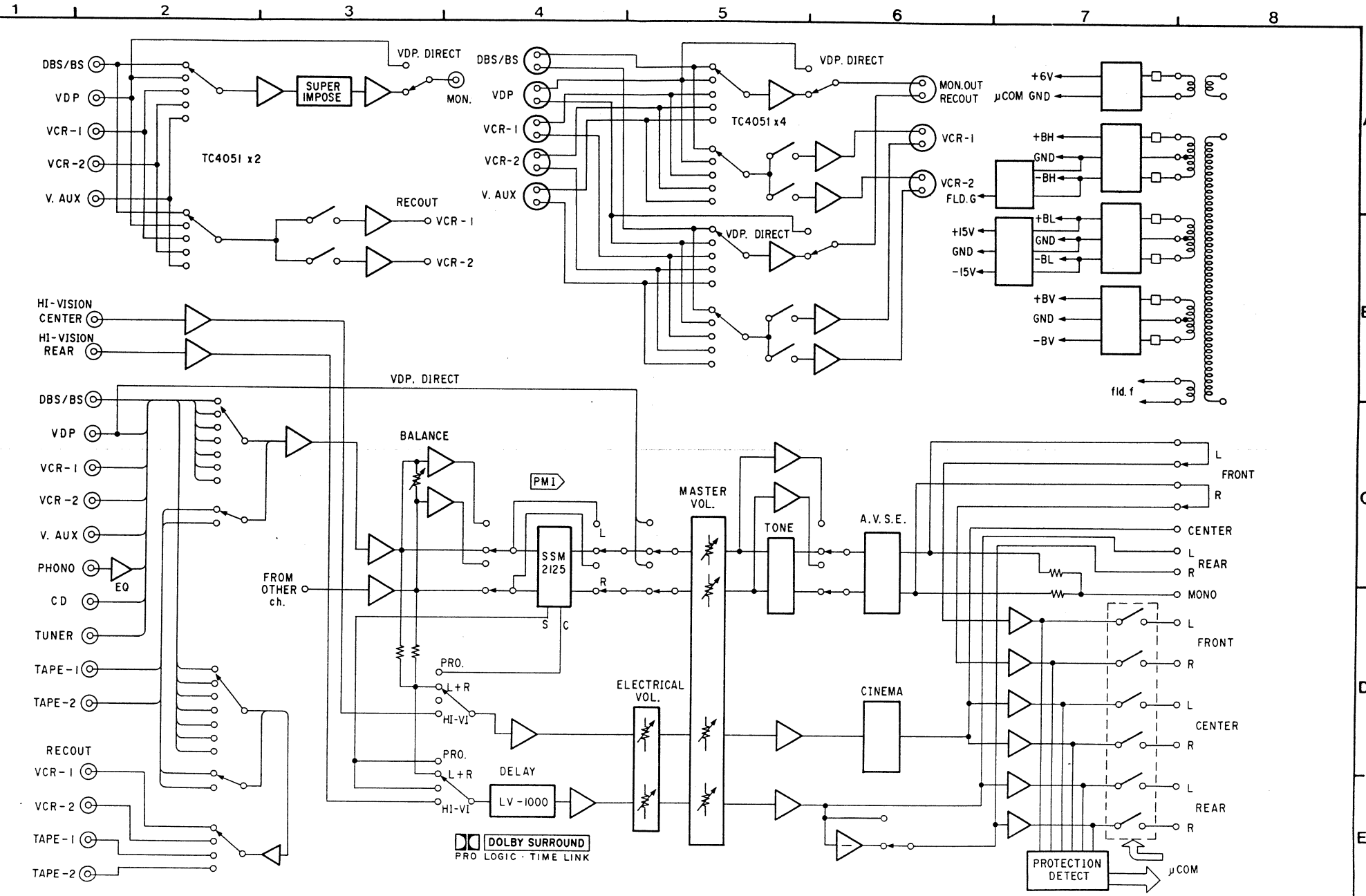

A
B
C
D
E

WIRING DIAGRAM

1 2 3 4 5 6 7 8

A

B

C

D

E

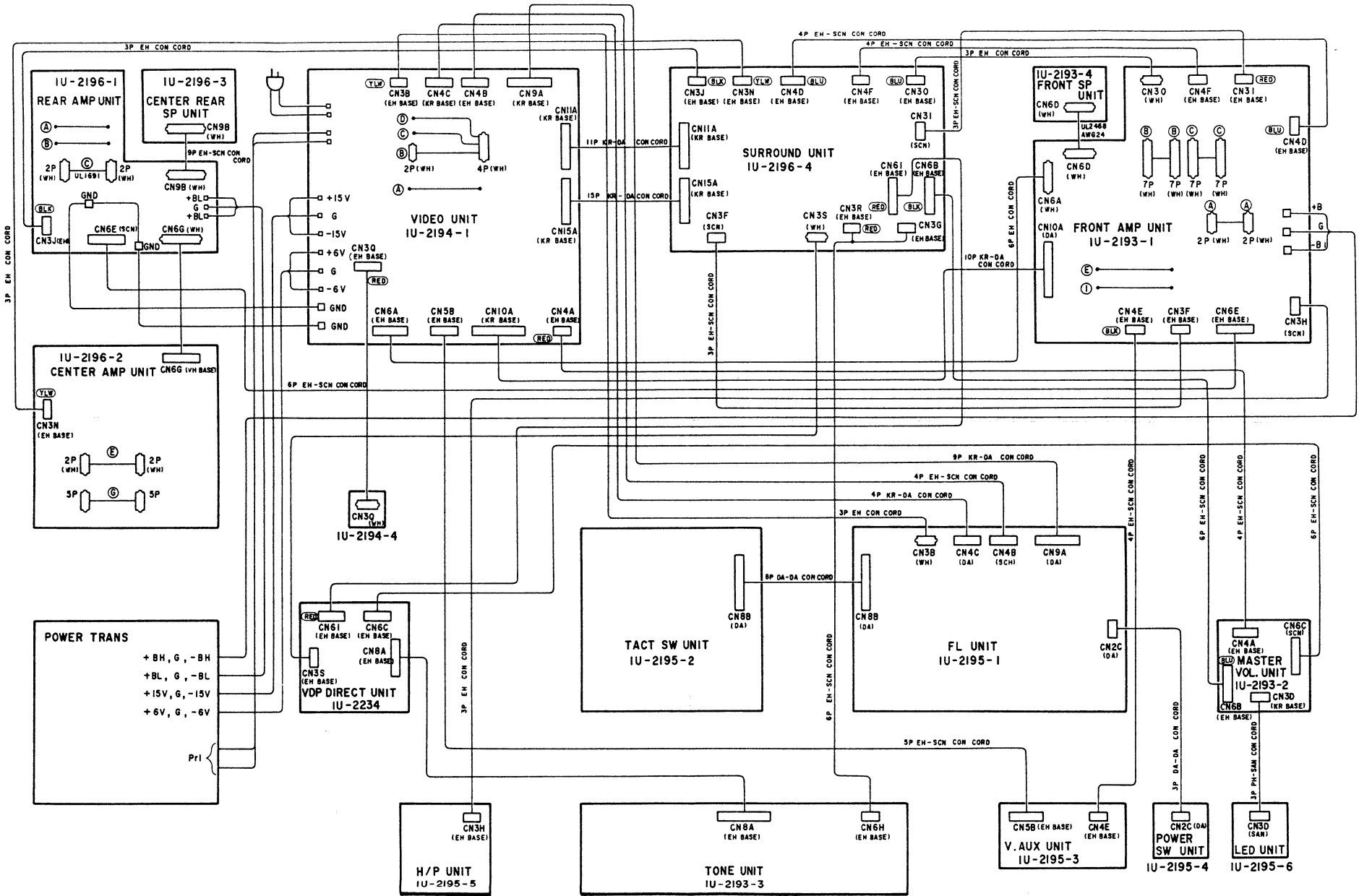

SCHEMATIC DIAGRAM (1/3) MAIN SECTION

1 2 3 4 5 6

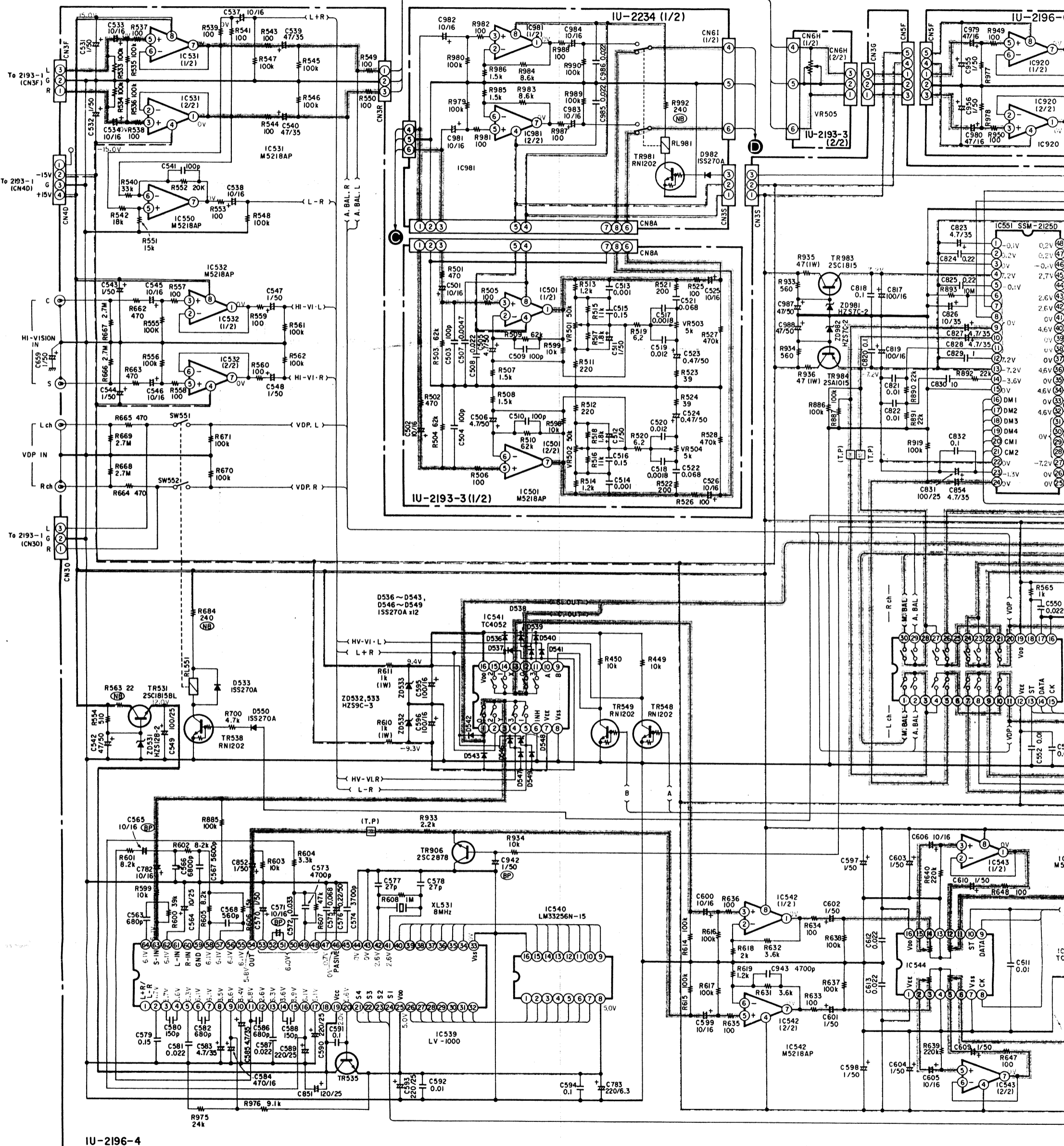

IU-2196-4

6

7

8

9

10

11

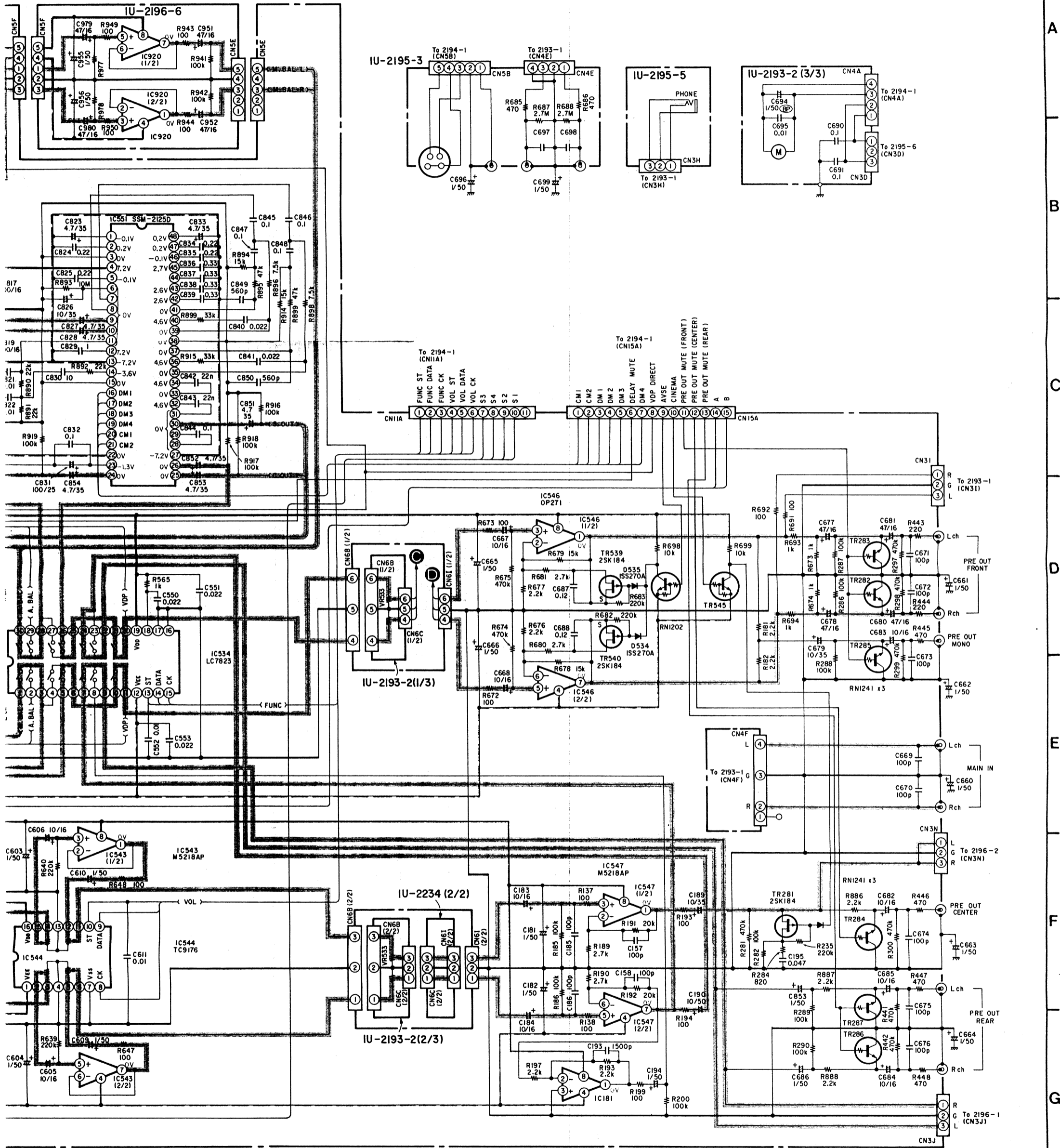

NOTE:
 - - - - - +B LINE
 - - - - - -B LINE
 // // // // // SIGNAL LINE

NOTES
 ALL RESISTANCE VALUES IN OHM. k=1,000 OHM, M=1,000,000 OHM
 ALL CAPACITANCE VALUES IN MICRO FARAD. P=MICRO-MICRO FARAD
 EACH VOLTAGE AND CURRENT ARE MEASURED AT NO SIGNAL INPUT CONDITION.
 CIRCUIT AND PARTS ARE SUBJECT TO CHANGE WITHOUT PRIOR NOTICE.

A
 B
 C
 D
 E
 F
 G
 H

SCHEMATIC DIAGRAM (2/3) VIDEO SECTION

1 2 3 4 5 6

A B C D E F G H

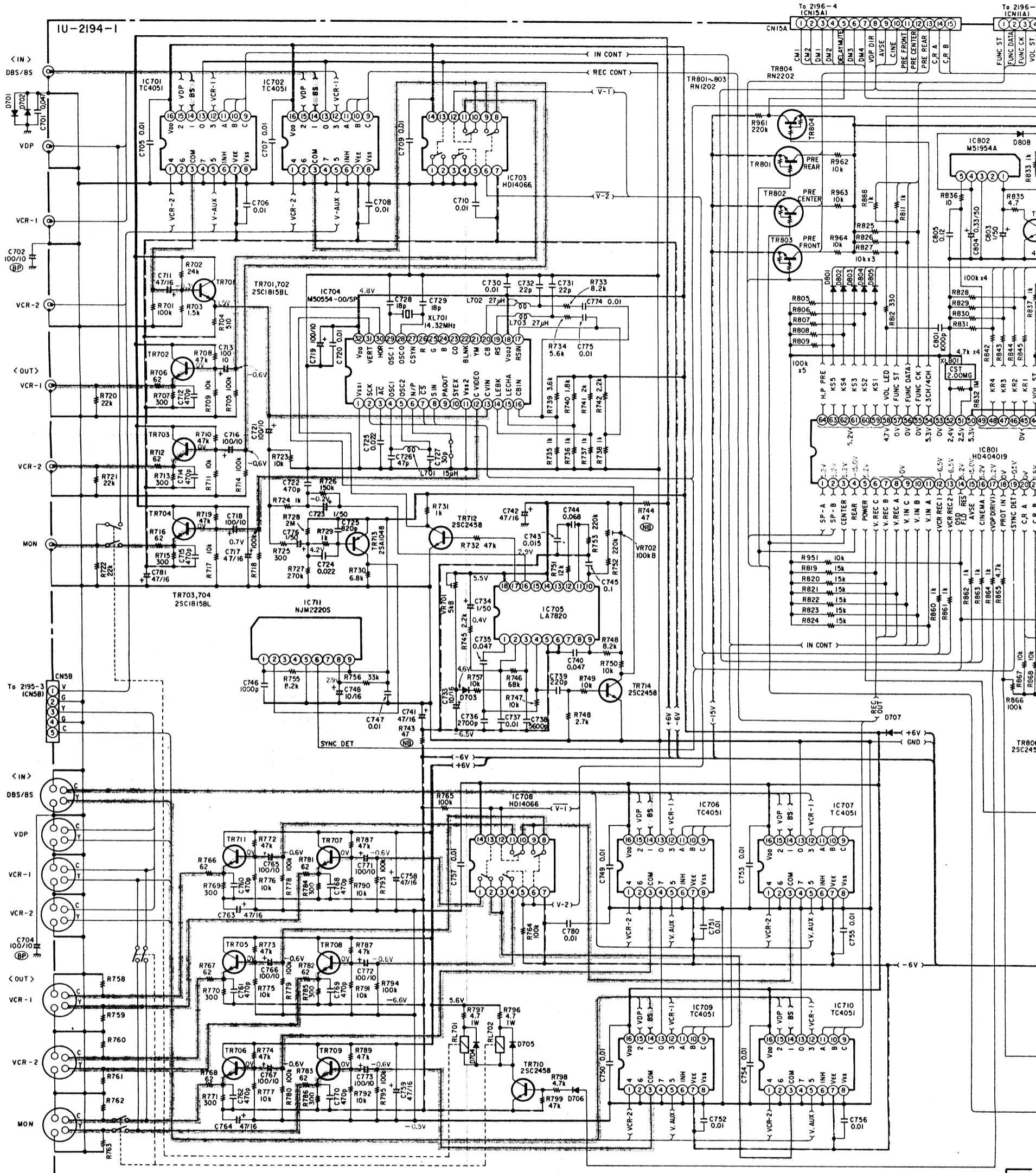

WARNING:
Parts marked with this symbol Δ have critical characteristics.
Use ONLY replacement parts recommended by the manufacturer.

CAUTION:
Before returning the unit to the customer, make sure you make either (1) a leakage current check or (2) a line to chassis resistance check. If the leakage current exceeds 0.5 milliamps, or if the resistance from chassis to either side of the power cord is less than 240 kohms, the unit is defective.

WARNING:
DO NOT return the unit to the customer until the problem is located and corrected.

NOTES
ALL RESISTANCE VALUES IN OHM. k=1,000 OHM, M=1,000,000 OHM.
ALL CAPACITANCE VALUES IN MICRO FARAD. P=MICRO-MICRO-FARAD.
EACH VOLTAGE AND CURRENT ARE MEASURED AT NO SIGNAL.
CIRCUIT AND PARTS ARE SUBJECT TO CHANGE WITHOUT NOTICE.

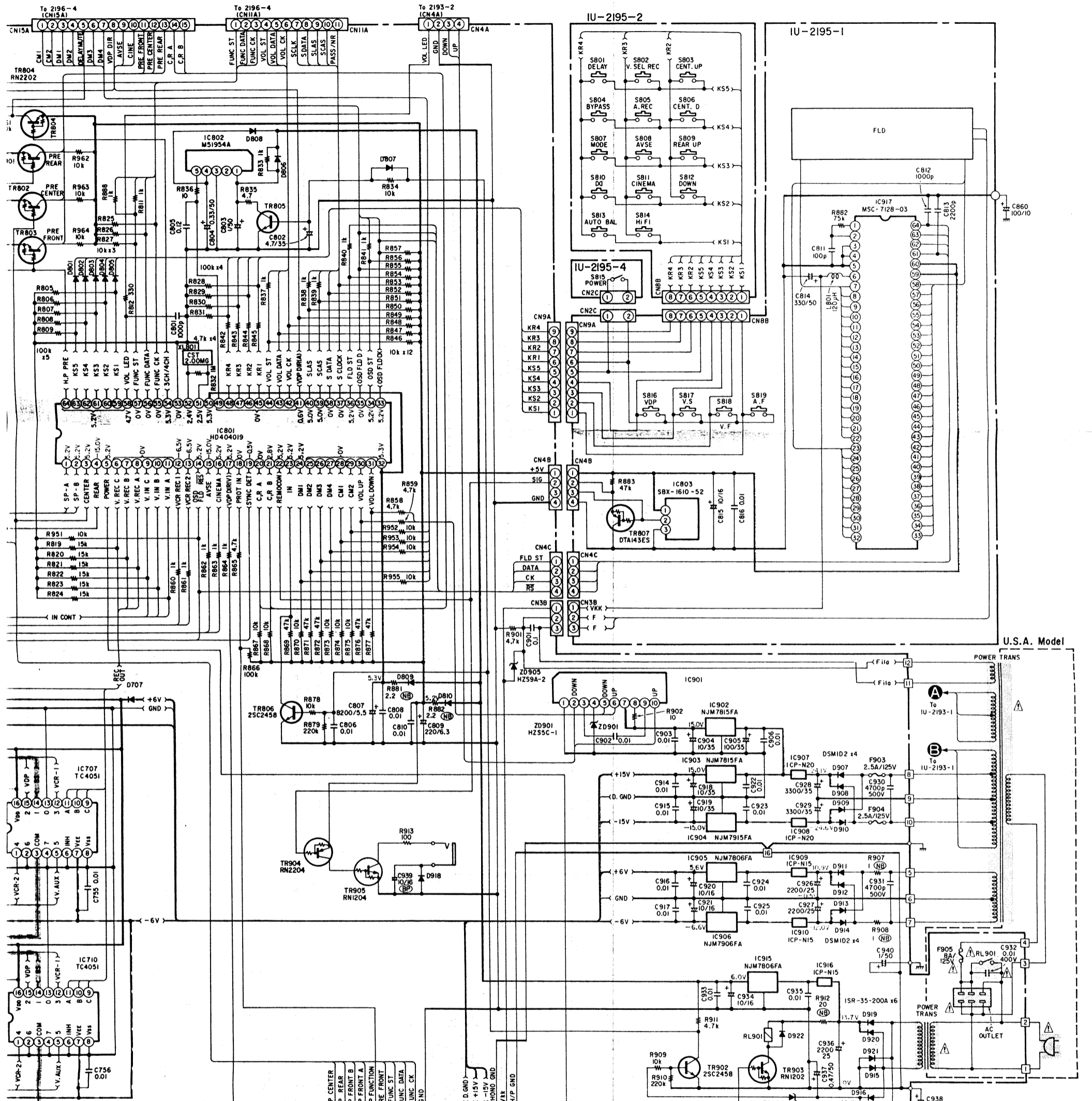

U.S.A. Model

NOTE:
 - - - - - +B LINE
 - - - - - -B LINE
 ———— SIGNAL LINE

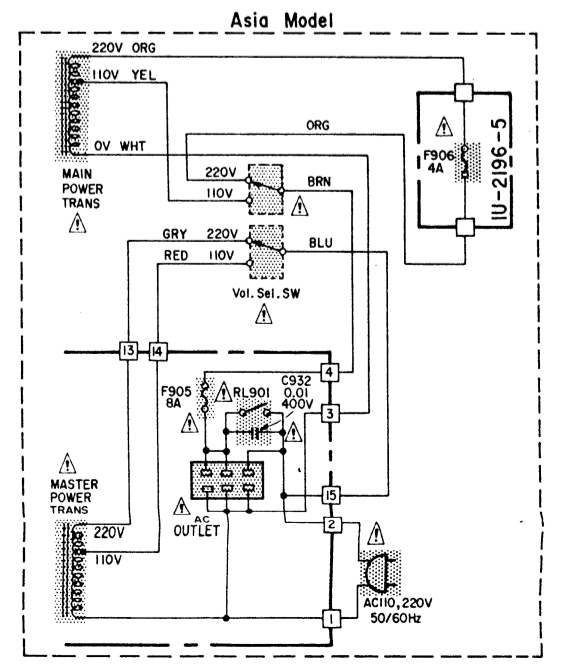

RESISTANCE VALUES IN OHM. k=1,000 OHM, M=1,000,000 OHM
 CAPACITANCE VALUES IN MICRO FARAD. P=MICRO-MICRO FARAD
 CH VOLTAGE AND CURRENT ARE MEASURED AT NO SIGNAL INPUT CONDITION.
 CIRCUIT AND PARTS ARE SUBJECT TO CHANGE WITHOUT PRIOR NOTICE.

SCHEMATIC DIAGRAM (3/3) AUDIO SECTION

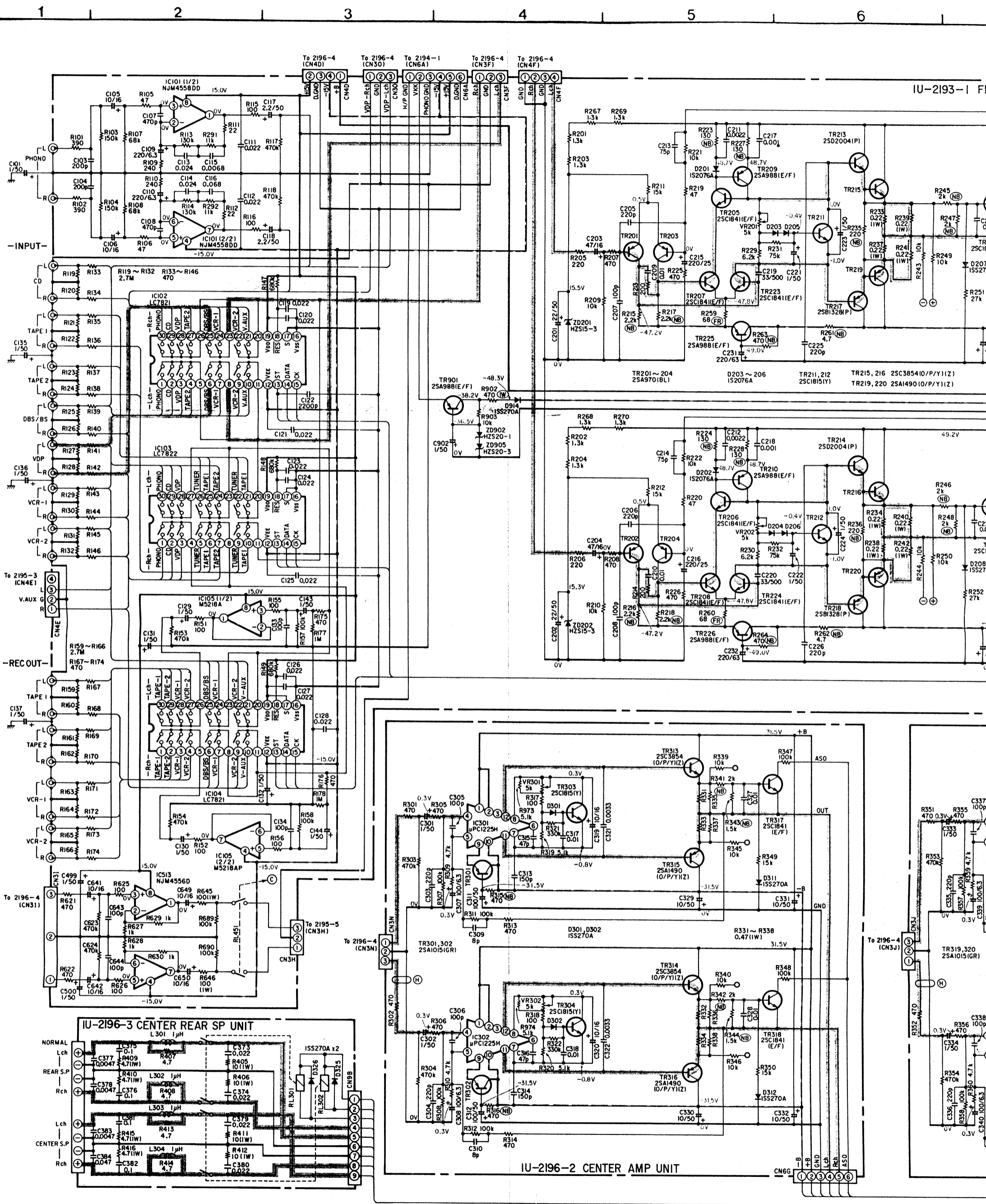

IU-2193-1 FF

IU-2196-3 CENTER REAR SP UNIT

IU-2196-2 CENTER AMP UNIT

6 7 8 9 10 11

A
B
C
D
E
F
G
H

IU-2193-1 FRONT AMP UNIT

IU-2193-4 FRONT SP UNIT

IU-2196-1 REAR AMP UNIT

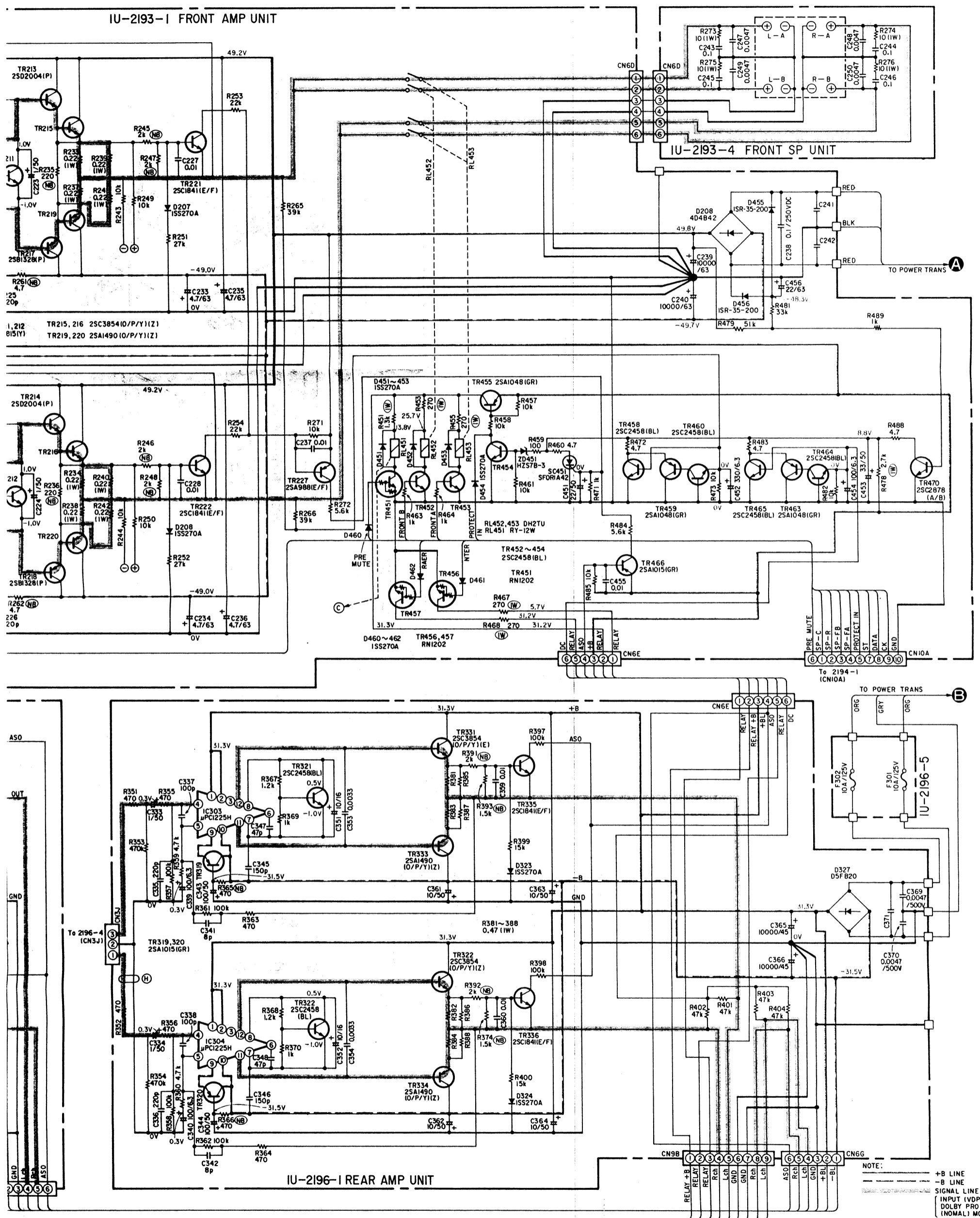

NOTE:
 --- +B LINE
 --- -B LINE
 --- SIGNAL LINE
 (INPUT TVDP) MODE.
 (DOLBY PRO LOGIC)
 (NORMAL) MODE.

NOTES
 ALL RESISTANCE VALUES IN OHM. K=1,000 OHM, M=1,000,000 OHM
 ALL CAPACITANCE VALUES IN MICRO FARAD. P=MICRO-MICRO FARAD
 EACH VOLTAGE AND CURRENT ARE MEASURED AT NO SIGNAL INPUT CONDITION.
 CIRCUIT AND PARTS ARE SUBJECT TO CHANGE WITHOUT PRIOR NOTICE.

EXPLODED VIEW OF CHASSIS AND CABINET

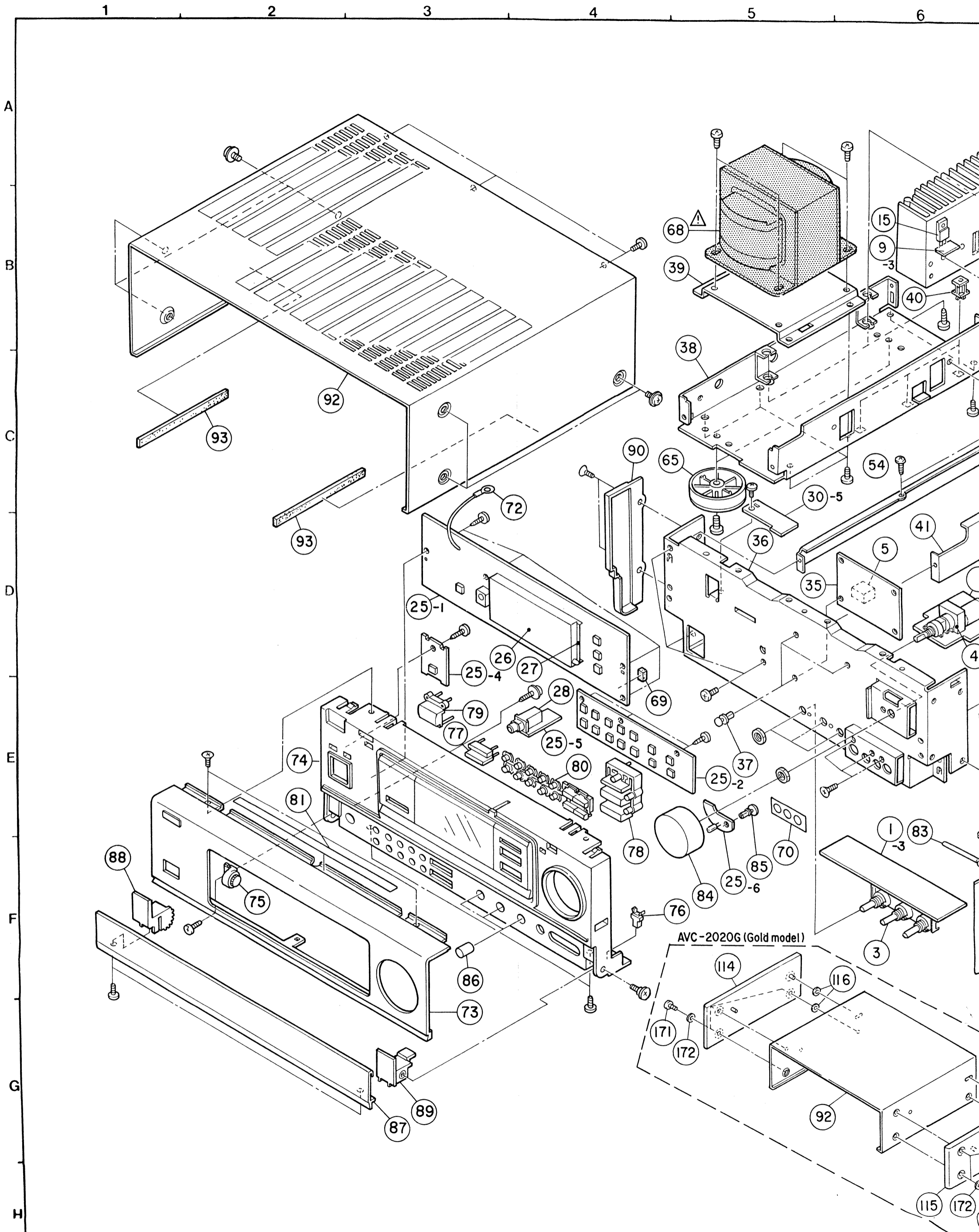

WARNING:

Parts marked with this symbol  have critical characteristics. Use ONLY replacement parts recommended by the manufacturer.

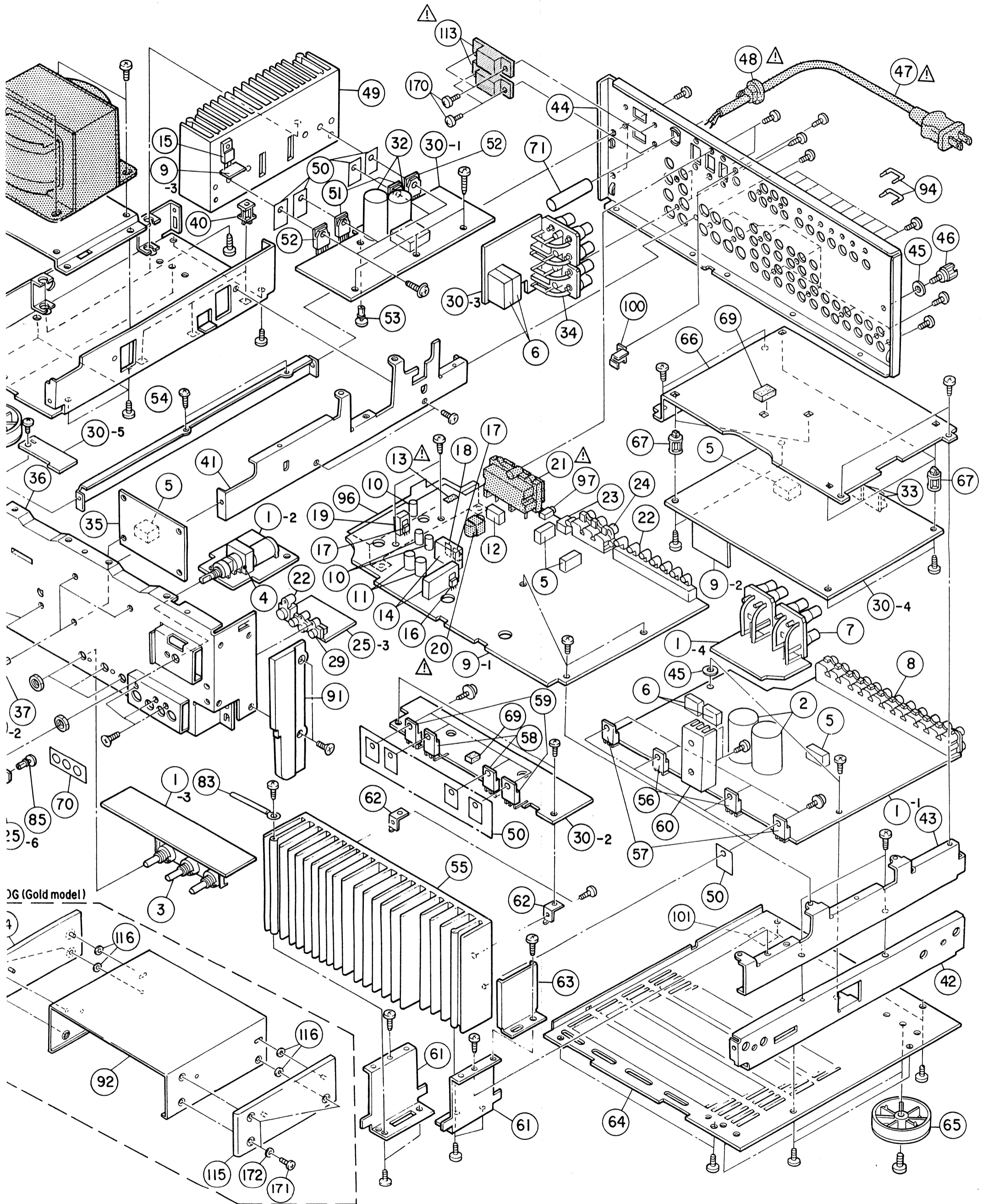

(Gold model)

PARTS LIST OF EXPLODED VIEW

Ref. No.	Part No.	Part Name	Remarks	Q'ty
1	Note	Front Amp Unit Ass'y		1 ^S
1-1	—	Front Amp Unit	(1)	(1)
1-2	—	Master Volume Unit	(1)	(1)
1-3	—	Tone Unit	(1)	(1)
1-4	—	Front Speaker Unit	(1)	(1)
2	254 6161 003	Chemicon 10000µF/63V	CE68W1J103M(DL) 3 Gang	2
3	211 0687 007	Variable Resistor	Master Vol.	1
4	211 0686 008	Variable Resistor 100KΩ		1
5	214 0127 003	Relay (RY-12W)		5
6	214 0129 001	Relay (DH2TU)		3
7	Note	8P Speaker Terminal		1
8	Note	6P Pin Jack(S-GND)		4
9	1U- 2194	Video Unit Ass'y		1 ^S
9-1	—	Video Unit	(1)	(1)
9-2	—	VKK Unit	(1)	(1)
9-3	—	+6V Unit	(1)	(1)
10	254 4256 091	Chemicon 2200µF/25V	CE04W1E222M	3
11	254 4259 014	Chemicon 3300µF/35V	CE04W1V332M	2
12	214 0120 000	Relay (TV-8)		1
13	Note	Fuse 5A	F905	1
14	417 0388 001	Radiator		2
15	263 0560 002	NJM7815FA Regulator	IC903	1
16	263 0561 001	NJM7915FA Regulator	IC904	1
17	262 1071 005	NJM7806FA Regulator	IC905,915	2
18	263 0683 002	NJM7906FA Regulator	IC906	1
19	417 9010 008	Radiator		1
20	Note	Power Trans (Mini)		1
21	203 3046 009	AC Outlet	Polarized	1
22	205 0605 000	S Terminal		8
23	204 8379 005	1P Pin Jack		1
24	204 8377 007	6P Pin Jack (S-GND)		1
25	1U- 2195	FL Unit Ass'y		1 ^S
25-1	—	FL Unit	(1)	(1)
25-2	—	Tact Switch Unit	(1)	(1)
25-3	—	V.AUX Unit	(1)	(1)
25-4	—	Power Switch Unit	(1)	(1)
25-5	—	H/Phone Unit	(1)	(1)
25-6	—	LED Unit	(1)	(1)
26	393 4115 000	FLD (FIP16X1JA)		1
27	412 3156 002	FLD Bracket		1
28	204 8341 004	Headphone Jack		1
29	204 8342 003	3P Pin Jack(C-GND)		1
30	Note	Rear Amp Unit Ass'y		1 ^S
30-1	—	Rear Amp Unit	(1)	(1)
30-2	—	Center Amp Unit	(1)	(1)
30-3	—	Center Rear Speaker Unit	(1)	(1)
30-4	—	Surround Unit	(1)	(1)
30-5	—	Fuse Unit	(1)	(1)
31	—	—		
32	254 6162 002	Chemicon 10000µF/ V	CE68W1J103M(DL)	2
33	204 8378 006	6P Pin Jack(S-GND)		2
34	Note	8P SP Terminal		1
35	1U- 2234	VDP Direct Unit Ass'y		1 ^S
36	411 1025 404	Front Chassis Ass'y		1
37	412 2741 036	P.W.B. Holder (H=10)		3
38	411 1026 209	Trans Chassis Ass'y		1
39	412 9160 102	Trans Bracket		1
40	415 9032 006	P.C.B. Holder (T)		3
41	411 1022 300	Center Chassis		1
42	411 9057 500	Side Chassis		1
43	412 3155 100	Support Bracket		1
44	Note	Rear Panel		1
45	477 0018 001	Washer (P-87)		2
46	205 0071 016	Terminal Ass'y		1

Ref. No.	Part No.	Part Name	Remarks	Q'ty
47	Note	AC Outlet		1
48	Note	AC Outlet		1
49	417 0415 204	Power Radiator (B)		1
50	415 0234 007	Insulating Sheet		12
51	271 0237 006	Transistor 2SA1490(O/P/M)(Z)		2
52	273 0386 005	Transistor 2SC3854(O/P/M)(Z)		2
53	412 2814 015	Card Spacer (L=14)		1
54	412 3154 101	Side Bracket		1
55	417 0414 108	Power Radiator (A)		1
56	271 0222 008	Transistor 2SA1492(O/P/Y)(Y)		2
57	273 0358 004	Transistor 2SC3856(O/P/Y)(Y)		2
58	271 0249 007	Transistor 2SA1490LB3 (O/P/M)(Z)		2
59	273 0400 004	Tansistor 2SC3854LB3 (O/P/Y)(Z)		2
60	417 0419 103	Mini Radiator		1
61	412 3150 008	Radiator Bracket (A)		2
62	412 3225 108	P.W.B. Bracket (A)		1
63	412 3271 000	Bracket		2
64	105 0930 103	Bottom Cover		1
65	104 0194 001	Foot Ass'y		4
66	411 1023 202	Shield Plate		1
67	443 9015 002	P.W. Spacer		6
68	Note	Power Trans		1
69	461 0390 054	Rubber Sheet		3
70	Note	Blind Sheet		1
71	—	—		
72	—	—		
73	Note	Front Panel Ass'y		1
74	Note	Inner Panel Ass'y		1
75	421 9007 007	Mini Dumper		1
76	435 0113 009	Latch (Y3Y18)		1
77	Note	Knob (VDP)		1
78	Note	Knob (Function)		1
79	Note	Push Knob (P)		1
80	Note	Function Sel. Knob		1
81	122 0183 049	Spacer		1
82	445 8004 007	Wire Clamper		15
83	445 0048 003	Cord Holder (L=76)		1
84	Note	VR Knob Ass'y		1
85	477 0096 007	Push Rivet		1
86	Note	Vol. Knob(B)		3
87	Note	Trap Door		1
88	Note	Hinge (L)		1
89	Note	Hinge (R)		1
90	Note	Side Plate (L)		1
91	Note	Side Plate (R)		1
92	Note	Top Cover		1
93	461 0334 007	Rubber Sheet		2
94	209 0103 009	Short Pin		2
95	—	—		
96	415 0595 005	Insulating Sheet		1
97	204 8260 004	Mini Jack		1
98	Note	Fuse 2.5A	F901, 902	2
99	Note	Fuse	F301, 302	1
100	Note	Safety Cover		1
101	Note	Dangerous Mark		1
SCREWS				
151	473 7007 000	Tapping Screw (S)4 x 8	Black	12
152	473 7015 005	Tapping Screw (S)3 x 6	Black	2
153	473 7015 018	Tapping Screw (S)3 x 8	Black	36
154	473 7511 004	F.Tapping Screw (P)3 x 10		4
155	473 7002 018	Tapping Screw (S)3 x 8		9
156	477 0064 107	Fixing Screw		22

Ref. No.	Part No.	Part Name	Remarks	Q'ty
157	473 8007 009	Cup Screw 3 x 12		12
158	473 7005 002	Tapping Screw (S)3 x 10		9
159	473 7501 001	Tapping Screw (P)3 x 10		10
160	473 7009 011	F.Tapping Screw (S)3 x 10		7
161	473 7501 027	Tapping Screw (P)3 x 16		4
162	477 0262 006	Special Screw		1
163	473 7002 021	Tapping Screw (S)3 x 8	Black	3
164	473 7500 044	Tapping Screw (P)3 x 8	Black	2
165	473 7514 001	Special Screw		1
166	Note	3P Sweling Screw		6
170	Note	Tapping Screw (P)3 x 10	Black	4
PACKING & ACCESSORIES (not included EXPLODED VIEW)				
201	GEN 1415 -2	Envelope Ass'y		1 ^S
201-1	505 8006 019	Envelope		1
201-2	511 2138 001	Inst. Manual		1
201-3	129 0129 004	Plate		1
201-4	499 0189 008	Remote Control Unit	RC-134	1
201-5	Note	DAI Warranty Home (4)		1
201-6	—	Battery	R03/AAA	2
202	504 0092 060	Styrene Paper	for AC Cord	1
203	504 9102 029	Styrene Paper	Set	1
204	505 9102 019	Poly Cover		1
205	503 0915 005	Cushion Ass'y		1
206	501 1494 037	Carton Case		1
207	—	—		
208	Note	Control Card Base		1
209	513 1349 004	Thermal Carbon Film		1

ADDENDUM LIST

Ref. No.	Parts Name & Descriptions	Parts No.			
		AVC-3020	AVC-2020		
		(Black)	(Black)	(Gold)	
1	Front Panel Ass'y	1U-2193B	1U-2193	1U-2193	
7	8P Speaker Terminal	205 0632 002	205 0472 013	205 0472 013	
9	Video Unit Ass'y	1U- 2194 B	1U- 2194	1U- 2194	
▲ 13	Fuse (F905)	206 1046 014 (8A)	206 1061 060 (8A/250V)	206 1061 060 (8A/250V)	
▲ 20	Power Trans (Mini)	233 5818 004	233 5793 006	233 5793 006	
30	Rear Amp Unit Ass'y	1U- 2196 B	1U- 2196	1U- 2196	
34	8P SP Terminal	205 0632 002	205 0472 013	205 0472 013	
44	Rear Panel	105 0945 033	105 0945 017	105 0945 020	
▲ 47	AC Cord	206 2060 002 (Polarized)	206 2083 005	206 2083 005	
▲ 48	Cord Bush	445 0056 008	445 0071 009	445 0071 009	
▲ 68	Power Trans	233 5897 009	233 5886 007	233 5886 007	
70	Blind Sheet	146 9045 100	146 9045 100	146 1117 007	
73	Front Panel Ass'y	144 2088 029	144 2088 003	144 2088 016	
74	Inner Panel Ass'y	146 1223 124	146 1223 108	146 1223 111	
77	Knob (VDP)	113 1410 102	113 1410 102	113 1410 115	
78	Knob (Function)	113 1411 101	113 1411 101	113 1411 114	
79	Push Knob (P)	113 1292 100	113 1292 100	113 1292 113	
80	Function Sel. Knob	113 1291 101	113 1291 101	113 1291 114	
84	VR Knob Ass'y	112 0569 103	112 0569 103	112 0569 132	
86	Vol. Knob (B)	112 0555 007	112 0555 007	112 0555 023	
87	Trap Door	144 2005 002	144 2005 002	144 2005 044	
88	Hinge (L)	401 0165 203	401 0165 203	401 0165 119	
89	Hinge (R)	401 0166 309	401 0166 309	401 0166 215	
90	Side Plate (L)	146 1204 101	146 1204 101	146 1204 114	
91	Side Plate (R)	146 1205 100	146 1205 100	146 1205 113	
92	Top Cover	102 0439 100	102 0439 100	102 0439 113	
▲ 96	Fuse (F901,902)	206 1053 076(2.5A)			
▲ 99	Fuse (F301,302)	206 1046 043 (10A)			
100	Safety Cover	412 3257 008	—	—	
101	Dangerous Mark	513 8266 009	—	—	
110	Fuse Label	—	513 1715 078(2)	513 1715 078(2)	
111	Fuse (F906)	—	206 1061 031 (4A/250V)	206 1061 031 (4A/250V)	
112	Preset Label	—	515 8030 008	515 8030 008	
▲ 113	Voltage Sel. Switch	—	212 1020 006(2)	212 1020 006(2)	
114	Wood Board (L)	—	—	101 2149 039	
115	Wood Board (R)	—	—	101 2143 035	
116	Felt Sheet	—	—	124 0032 015	
SCREWS					
166	3P Swelling Screw	477 0263 005(6)	477 0263 005(6)	—	
170	Tapping Screw(P) 3x10 Black	473 7508 017(4)	473 7508 017(8)	473 7508 017(8)	
171	Tapping Screw(S) 4x20 Black	—	—	473 7007 039(6)	
172	Washer #5	—	—	475 1006 016(6)	
173					
174					
PACKING & ACCESSORIES (not included EXPLODED VIEW)					
201-5	DAI Warranty Home (4)	515 0418 408	—	—	
206	Carton Case	501 1494 037	501 1494 066	501 1494 024	

NOTE FOR PARTS LIST

- Part indicated with the mark "◎" are not always in stock and possibly to take a long period of time for supplying, or in some case supplying of part may be refused.
- When ordering of part, clearly indicate "1" and "1" (i) to avoid mis-supplying.
- Ordering part without stating its part number can not be supplied.
- Part indicated with the mark "*" is not illustrated in the exploded view.

WARNING:
Parts marked with this symbol ▲ have critical characteristics.
Use ONLY replacement parts recommended by the manufacturer.

REMOTE CONTROL SCHEMATIC DIAGRAM

1 2 3 4 5 6 7 8

A

B

C

D

E

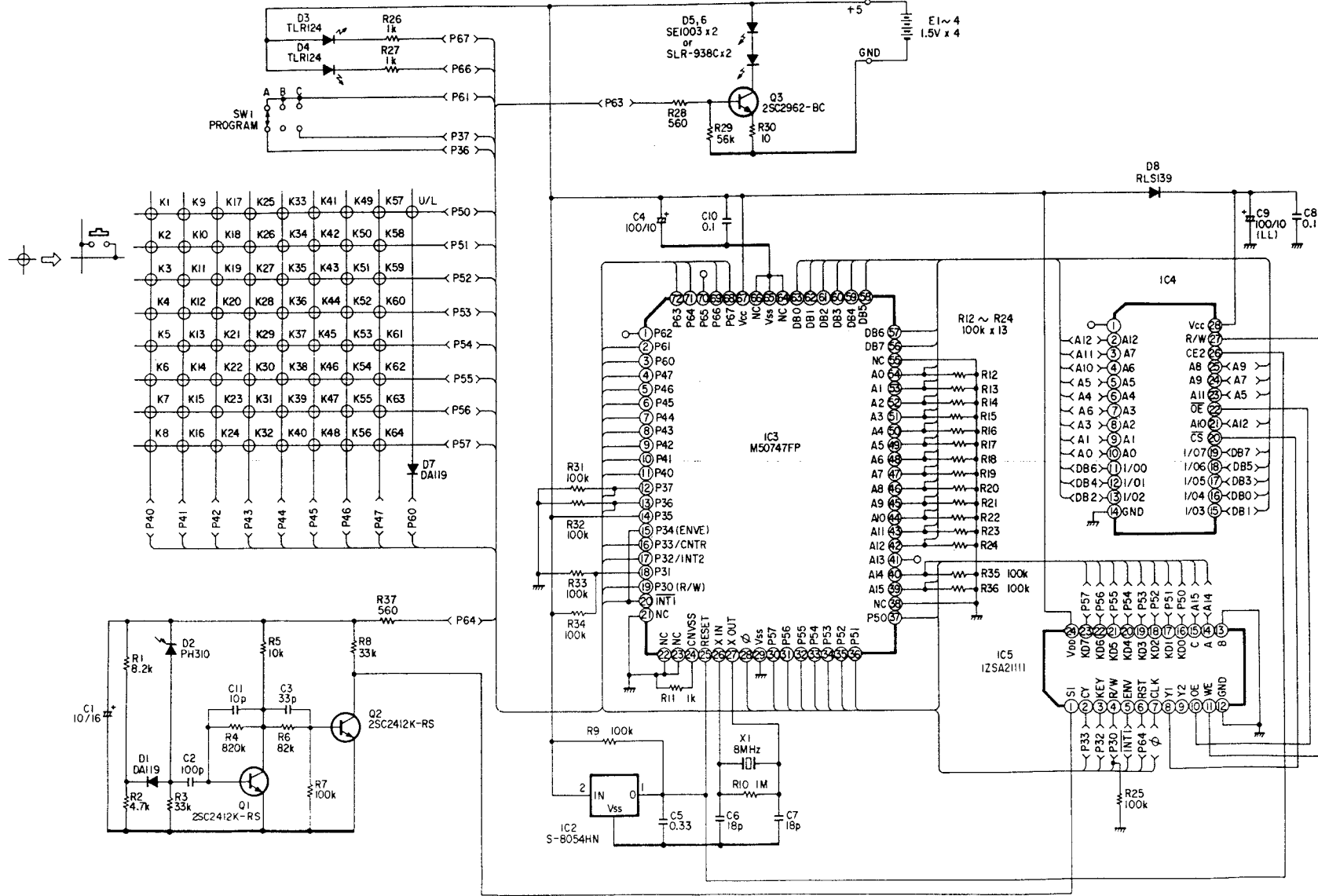

NOTES
 ALL RESISTANCE VALUES IN OHM. k=1,000 OHM, M=1,000,000 OHM
 ALL CAPACITANCE VALUES IN MICRO FARAD. P=MICRO-MICRO FARAD
 EACH VOLTAGE AND CURRENT ARE MEASURED AT NO SIGNAL INPUT CONDITION.
 CIRCUIT AND PARTS ARE SUBJECT TO CHANGE WITHOUT PRIOR NOTICE.

EXPLODED VIEW

1 2 3 4 5 6 7 8

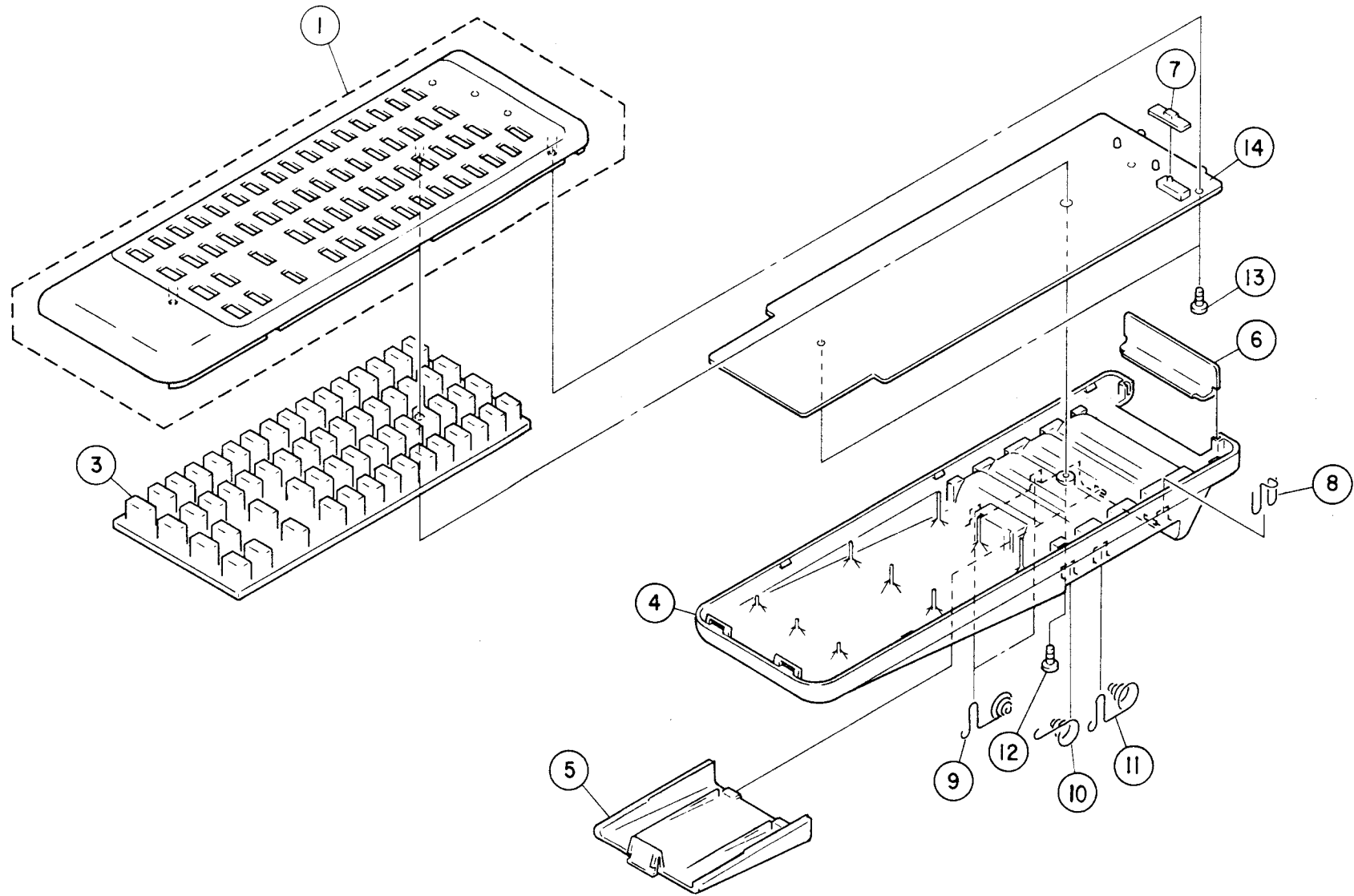

A
B
C
D
E

REMOTE CONTROL UNIT ASS'Y

Ref. No.	Part No.	Part Name	Remarks
SEMICONDUCTORS			
IC2	9H3 1000 021	IC S-8054HN	VOL. Detector
IC3	9H3 1000 091	IC TZSA21287	μ-com
IC4	9H3 1000 067	IC TC5564APL15	RAM CMOS
or		IC TC5564AFL15	RAM CMOS
IC5		IC μPD65005G259	Gate Array
or	9H3 1000 068	IC IZSA21111	
Q1,2	9H3 1000 069	Transistor 2SC2412R/S	Chip
Q3	9H3 1000 070	Transistor 2SC2982B/C	Chip
D1	9H3 1000 071	Diode DA119/118	Chip
D2	9H3 1000 029	Diode PH310	Photo
D3,4	9H3 1000 028	LED TLR124	Red
D5,6	9H3 1000 072	LED SE1003C (Infrared-Ray)	
D7	9H3 1000 071	Diode DA119/118	Chip
E.U. PARTS			
X1	9H3 1000 073	X'tal 8MHz	1
SW1	9H3 1000 074	Slide Switch	1
CAPACITORS			
C1		Electrolytic 47μF/10V	Chip
C2		Ceramic 100PF/50V	Chip
C3		Ceramic 10PF/50V	Chip
C4		Electrolytic 100μF/10V	Chip
C5		Ceramic 0.33μF/25V	Chip
C6,7		Ceramic 18PF/50V	Chip
C8		Ceramic 0.1μF/25V	Chip
C9		Electrolytic 100μF/10V	Chip
C10		Ceramic 0.1μF/25V	Chip
C11		Ceramic 10PF/50V	Chip
RESISTORS			
R1		Chip 8.2KΩ, 1/16W	RM73M-822J
R2		Chip 4.7KΩ, 1/16W	RM73M-472J
R3		Chip 33KΩ, 1/16W	RM73M-333J
R4		Chip 820KΩ, 1/16W	RM73M-824J
R5		Chip 10KΩ, 1/16W	RM73M-103J
R6		Chip 82KΩ, 1/16W	RM73M-823J
R7		Chip 100KΩ, 1/16W	RM73M-104J
R8		Chip 33KΩ, 1/16W	RM73M-333J
R9		Chip 100KΩ, 1/16W	RM73M-104J
R10		Chip 1MΩ, 1/16W	RM73M-105J
R11		Chip 1KΩ, 1/16W	RM73M-102J
R12-24		Chip 100KΩ, 1/16W	RM73M-104J
R25		Chip 100KΩ, 1/16W	RM73M-104J
R26,27		Chip 1KΩ, 1/16W	RM73M-102J
R28		Chip 560Ω, 1/16W	RM73M-561J
R29		Chip 56KΩ, 1/16W	RM73M-563J
R30		Chip 10Ω, 1/16W	RM73M-100J
R31,32		Chip 100KΩ, 1/16W	RM73M-104J

Ref. No.	Part No.	Part Name	Remarks
R33		Chip 100KΩ, 1/16W	RM73M-104J
R34		Chip 100KΩ, 1/16W	RM73M-104J
R35,36		Chip 100KΩ, 1/16W	RM73M-104J
R37		Chip 560Ω, 1/16W	RM73M-561J
OTHER PARTS			
J1-24	9H3 1000 092	P.W.Board Jumper (Chip)	(1) 24

PARTS LIST OF EXLODED VIEW

Ref. No.	Part No.	Part Name	Remarks	Q'ty
1	9H3 1000 094	Case Top Ass'y		1
2	—	—		
3	9H3 1000 093	Switch Rubber		1
4	9H3 1000 056	Case Bottom Ass'y		1
5	9H3 1000 057	Cover Battery		1
6	9H3 1000 058	IR Filter		1
7	9H3 1000 060	Switch Button		1
8	9H3 1000 064	Terminal Battery		1
9	9H3 1000 061	Spring Coil		2
10	9H3 1000 062	Spring Coil		1
11	9H3 1000 063	Spring Coil		1
12	—	Tapping Screw 2 x 6		1
13	—	Tapping Screw 2 x 5		2
14	—	P.W.Unit Ass'y		1 ^S

KEY LAYOUT

↑ Transmitting direction (upper side)

K5	K6	K7	K8
K13	K14	K15	K16
K21	K22	K23	K24
K29	K30	K31	K32
K37	K38	K39	K40
K45	K46	K47	K48
K53	K54	K55	K56
K61	K62	K63	K64
K57	K58	K59	K60
K49	K50	K51	K52
K41	K42	K43	K44
K33	K34	K35	K36
K25	K26	K27	K28
K17	K18	K19	K20
K9	K10	K11	K12
K1	K2	K3	K4

KEYBOARD PORT MAP

Microcomputer Port	P50	P51	P52	P53	P54	P55	P56	P57
P40	K1	K2	K3	K4	K5	K6	K7	K8
P41	K9	K10	K11	K12	K13	K14	K15	K16
P42	K17	K18	K19	K20	K21	K22	K23	K24
P43	K25	K26	K27	K28	K29	K30	K31	K32
P44	K33	K34	K35	K36	K37	K38	K39	K40
P45	K41	K42	K43	K44	K45	K46	K47	K48
P46	K49	K50	K51	K52	K53	K54	K55	K56
P47	K57	K58	K59	K60	K61	K62	K63	K64
P60	USE/LEARN							