

DENON

Ver. 3

Please refer to the
MODIFICATION NOTICE.

SERVICE MANUAL

MODEL	JP	E3	E3B	E2	EK	EA	E1	E1C
AVR-1311				✓				✓
AVR-391		✓				✓		

AV SURROUND RECEIVER

MODEL	JP	E3	E3B	E2	EK	EA	E1	E1C
DHT-1311XP				✓				
DHT-391XP		✓	✓ 2			✓		

5.1CH HOME THEATER SYSTEM

• For purposes of improvement, specifications and design are subject to change without notice.

• Please use this service manual with referring to the operating instructions without fail.

• Some illustrations using in this service manual are slightly different from the actual set.

SAFETY PRECAUTIONS

The following check should be performed for the continued protection of the customer and service technician.

LEAKAGE CURRENT CHECK

Before returning the unit to the customer, make sure you make either (1) a leakage current check or (2) a line to chassis resistance check. If the leakage current exceeds 0.5 milliamps, or if the resistance from chassis to either side of the power cord is less than 460 kohms, the unit is defective.

Be sure to test for leakage current with the AC plug in both polarities, in addition, in each power ON, OFF and STANDBY mode, if applicable.

CAUTION Please heed the points listed below during servicing and inspection.

◎ **Heed the cautions!**

Spots requiring particular attention when servicing, such as the cabinet, parts, chassis, etc., have cautions indicated on labels. Be sure to heed these cautions and the cautions indicated in the handling instructions.

◎ **Caution concerning electric shock!**

(1) An AC voltage is impressed on this set, so touching internal metal parts when the set is energized could cause electric shock. Take care to avoid electric shock, by for example using an isolating transformer and gloves when servicing while the set is energized, unplugging the power cord when replacing parts, etc.

(2) There are high voltage parts inside. Handle with extra care when the set is energized.

◎ **Caution concerning disassembly and assembly!**

Through great care is taken when manufacturing parts from sheet metal, there may in some rare cases be burrs on the edges of parts which could cause injury if fingers are moved across them. Use gloves to protect your hands.

◎ **Only use designated parts!**

The set's parts have specific safety properties (fire resistance, voltage resistance, etc.). For replacement parts, be sure to use parts which have the same properties. In particular, for the important safety parts that are marked \triangle on wiring diagrams and parts lists, be sure to use the designated parts.

◎ **Be sure to mount parts and arrange the wires as they were originally!**

For safety reasons, some parts use tape, tubes or other insulating materials, and some parts are mounted away from the surface of printed circuit boards. Care is also taken with the positions of the wires, solder and clamps are used to keep wires away from heating and high voltage parts, so be sure to set everything back as it was originally.

◎ **Inspect for safety after servicing!**

Check that all screws, parts and wires removed or disconnected for servicing have been put back in their original positions, inspect that no parts around the area that has been serviced have been negatively affected, conduct an insulation check on the external metal connectors and between the blades of the power plug, and otherwise check that safety is ensured.

(Insulation check procedure)

Unplug the power cord from the power outlet, disconnect the antenna, plugs, etc., and turn the power switch on. Using a 500V insulation resistance tester, check that the inplug and the externally exposed metal parts (antenna terminal, headphones terminal, input terminal, etc.) is 1M Ω or greater. If it is less, the set must be inspected and repaired.

CAUTION Concerning important safety parts

Many of the electric and structural parts used in the set have special safety properties. In most cases these properties are difficult to distinguish by sight, and using replacement parts with higher ratings (rated power and withstand voltage) does not necessarily guarantee that safety performance will be preserved. Parts with safety properties are indicated as shown below on the wiring diagrams and parts lists in this service manual. Be sure to replace them with parts with the designated part number.

(1) Schematic diagrams Indicated by the \triangle mark.

(2) Parts lists Indicated by the \triangle mark.

Using parts other than the designated parts could result in electric shock, fires or other dangerous situations.

NOTE FOR SCHEMATIC DIAGRAM

WARNING:

Parts marked with this symbol \triangle have critical characteristics. Use ONLY replacement parts recommended by the manufacturer.

CAUTION:

Before returning the unit to the customer, make sure you make either (1) a leakage current check or (2) a line to chassis resistance check. If the leakage current exceeds 0.5 milliamps, or if the resistance from chassis to either side of the power cord is less than 460 kohms, the unit is defective.

WARNING:

DO NOT return the unit to the customer until the problem is located and corrected.

NOTICE:

ALL RESISTANCE VALUES IN OHM. k=1,000 OHM / M=1,000,000 OHM

ALL CAPACITANCE VALUES IN MICRO FARAD. P=MICRO-MICRO FARAD EACH VOLTAGE AND CURRENT ARE MEASURED AT NO SIGNAL INPUT CONDITION. CIRCUIT AND PARTS ARE SUBJECT TO CHANGE WITHOUT PRIOR NOTICE.

NOTE FOR PARTS LIST

- Parts for which "nsp" is indicated on this table cannot be supplied.
- When ordering of part, clearly indicate "1" and "I" (i) to avoid mis-supplying.
- Ordering part without stating its part number can not be supplied.
- Part indicated with the mark "★" is not illustrated in the exploded view.
- Not including General-purpose Carbon Film Resistor in the P.W.Board parts list. (Refer to the Schematic Diagram for those parts.)
- Not including General-purpose Carbon Chip Resistor in the P.W.Board parts list. (Refer to the Schematic Diagram for those parts.)

WARNING: Parts marked with this symbol \triangle have critical characteristics. Use ONLY replacement parts recommended by the manufacturer.

● Resistors

Ex.:

RN	14K	2E	182	G	FR
Type	Shape and performance	Power	Resistance	Allowable error	Others

RD: Carbon	2B: 1/8 W	F: $\pm 1\%$	P: Pulse-resistant type
RC: Composition	2E: 1/4 W	G: $\pm 2\%$	NL: Low noise type
RS: Metal oxide film	2H: 1/2 W	J: $\pm 5\%$	NB: Non-burning type
RW: winding	3A: 1 W	K: $\pm 10\%$	FR: Fuse-resistor
RN: Metal film	3D: 2 W	M: $\pm 20\%$	F: Lead wire forming
RK: Metal mixture	3F: 3 W		
	3H: 5 W		

* Resistance

$\frac{1}{\uparrow} \frac{8}{\uparrow} \frac{2}{\uparrow} \Rightarrow 1800\text{ohm}=1.8\text{kohm}$
 Indicates number of zeros after effective number.
 2-digit effective number.

$\frac{1}{\uparrow} \frac{R}{\uparrow} \frac{2}{\uparrow} \Rightarrow 1.2\text{ohm}$
 1-digit effective number.
 2-digit effective number, decimal point indicated by R.
 : Units: ohm

● Capacitors

Ex.:

CE	04W	1H	3R2	M	BP
Type	Shape and performance	Dielectric strength	Capacity	Allowable error	Others

CE: Aluminum foil electrolytic	0J: 6.3 V	F: $\pm 1\%$	HS: High stability type
CA: Aluminium solid electrolytic	1A: 10 V	G: $\pm 2\%$	BP: Non-polar type
CS: Tantalum electrolytic	1C: 16 V	J: $\pm 5\%$	HR: Ripple-resistant type
CQ: Film	1E: 25 V	K: $\pm 10\%$	DL: For charge and discharge
CK: Ceramic	1V: 35 V	M: $\pm 20\%$	HF: For assuring high frequency
CC: Ceramic	1H: 50 V	Z: $\pm 80\%$	U: UL part
CP: Oil	2A: 100 V	: -20%	C: CSA part
CM: Mica	2B: 125 V	P: +100%	W: UL-CSA part
CF: Metallized	2C: 160 V	C: $\pm 0.25\text{pF}$	F: Lead wire forming
CH: Metallized	2D: 200 V	D: $\pm 0.5\text{pF}$	
	2E: 250 V	=: Others	
	2H: 500 V		
	2J: 630 V		

* Capacity (electrolyte only)

$\frac{2}{\uparrow} \frac{2}{\uparrow} \frac{2}{\uparrow} \Rightarrow 2200 \mu\text{F}$
 Indicates number of zeros after effective number.
 · Units: μF .

$\frac{2}{\uparrow} \frac{R}{\uparrow} \frac{2}{\uparrow} \Rightarrow 2.2 \mu\text{F}$
 1-digit effective number.
 2-digit effective number, decimal point indicated by R
 · Units: μF .

* Capacity (except electrolyte)

$\frac{2}{\uparrow} \frac{2}{\uparrow} \frac{2}{\uparrow} \Rightarrow 2200\text{pF}=0.0022 \mu\text{F}$
 Indicates number of zeros after effective number. (More than 2)
 2-digit effective number.
 · Units:pF

$\frac{2}{\uparrow} \frac{2}{\uparrow} \frac{1}{\uparrow} \Rightarrow 220\text{pF}$
 Indicates number of zeros after effective number. (0 or 1)
 2-digit effective number.
 · Units:pF

· When the dielectric strength is indicated in AC,"AC" is included after the dielectric strength value.

SYSTEM CONFIGURATION

- AVR-1311
- AVR-391

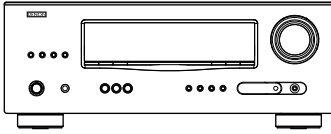

- DHT-1311XP (AVR-1311 + SYS-391HT)
- DHT-391XP (AVR-391 + SYS-391HT)

SYS-391HT : Refer to page 104-113 for the service manual.

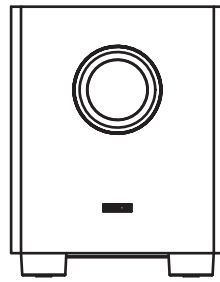

DSW-391



SC-F391(x2)

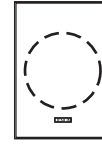

SC-R391(x2)

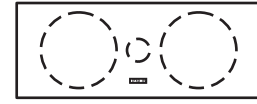

SC-C391

SYS-391HT

TECHNICAL SPECIFICATIONS

□ Audio Section

• Power amplifier

Rated output :

Front :

75 W + 75 W (8 Ω, 20 Hz – 20 kHz with 0.08 % T.H.D.)
110 W + 110 W (6 Ω, 1 kHz with 0.7 % T.H.D.)

Center :

75 W (8 Ω, 20 Hz – 20 kHz with 0.08 % T.H.D.)
110 W (6 Ω, 1 kHz with 0.7 % T.H.D.)

Surround :

75 W + 75 W (8 Ω, 20 Hz – 20 kHz with 0.08 % T.H.D.)
110 W + 110 W (6 Ω, 1 kHz with 0.7 % T.H.D.)

Output connectors : 6 – 16 Ω

• Analog

Input sensitivity/Input impedance : 200 mV/47 kΩ

Frequency response: 10 Hz – 100 kHz — +1, –3 dB (DIRECT mode)

S/N : 98 dB (IHF-A weighted, DIRECT mode)

□ Video Section

• Standard video connectors

Input/output level and impedance : 1 Vp-p, 75 Ω

Frequency response : 5 Hz – 10 MHz — +1, –3 dB

• Color component video connector

Input/output level and impedance :

Y (brightness) signal — 1 Vp-p, 75 Ω

P_B / C_B signal — 0.7 Vp-p, 75 Ω

P_R / C_R signal — 0.7 Vp-p, 75 Ω

Frequency response : 5 Hz – 10 MHz — +1, –3 dB

□ Tuner section

[FM] (Note: μV at 75 Ω, 0 dBf = 1 x 10⁻¹⁵ W)

Receiving Range (for 391E3, 391E3B) : △

[FM] 87.5 MHz – 107.9 MHz [AM] 520 kHz – 1710 kHz

Receiving Range (for 1311E2, 1311E1C, 391EA) :

[FM] 87.5 MHz – 108.0 MHz [AM] 522 kHz – 1611 kHz

Usable Sensitivity :

[FM] 1.2 μV (12.8 dBf) [AM] 18 μV

50 dB Quietening Sensitivity :

[FM] MONO 2.8 μV (20.2 dBf)

S/N (IHF-A) :

[FM] MONO 70 dB
STEREO 67 dB

Total harmonic Distortion (at 1 kHz) :

[FM] MONO 0.7 %
STEREO 1.0 %

□ General

Power supply (for 391E3, 391E3B) : AC 120 V, 60 Hz △
(for 1311E2, 391EA) : AC 230 V, 50 Hz
(for 1311E1C) : AC 220 V, 50 Hz

Power consumption :

330 W
Less than 0.5 W (Standby)

Maximum external dimensions :

435 (W) x 166 (H) x 381 (D) mm

Weight : 9.2 kg

□ Remote Control Unit (RC-1149)

Batteries : R03/AAA Type (two batteries)

Maximum external dimensions : 50 (W) x 211 (H) x 22 (D) mm

Weight : 110 g (including batteries)

DIMENSION

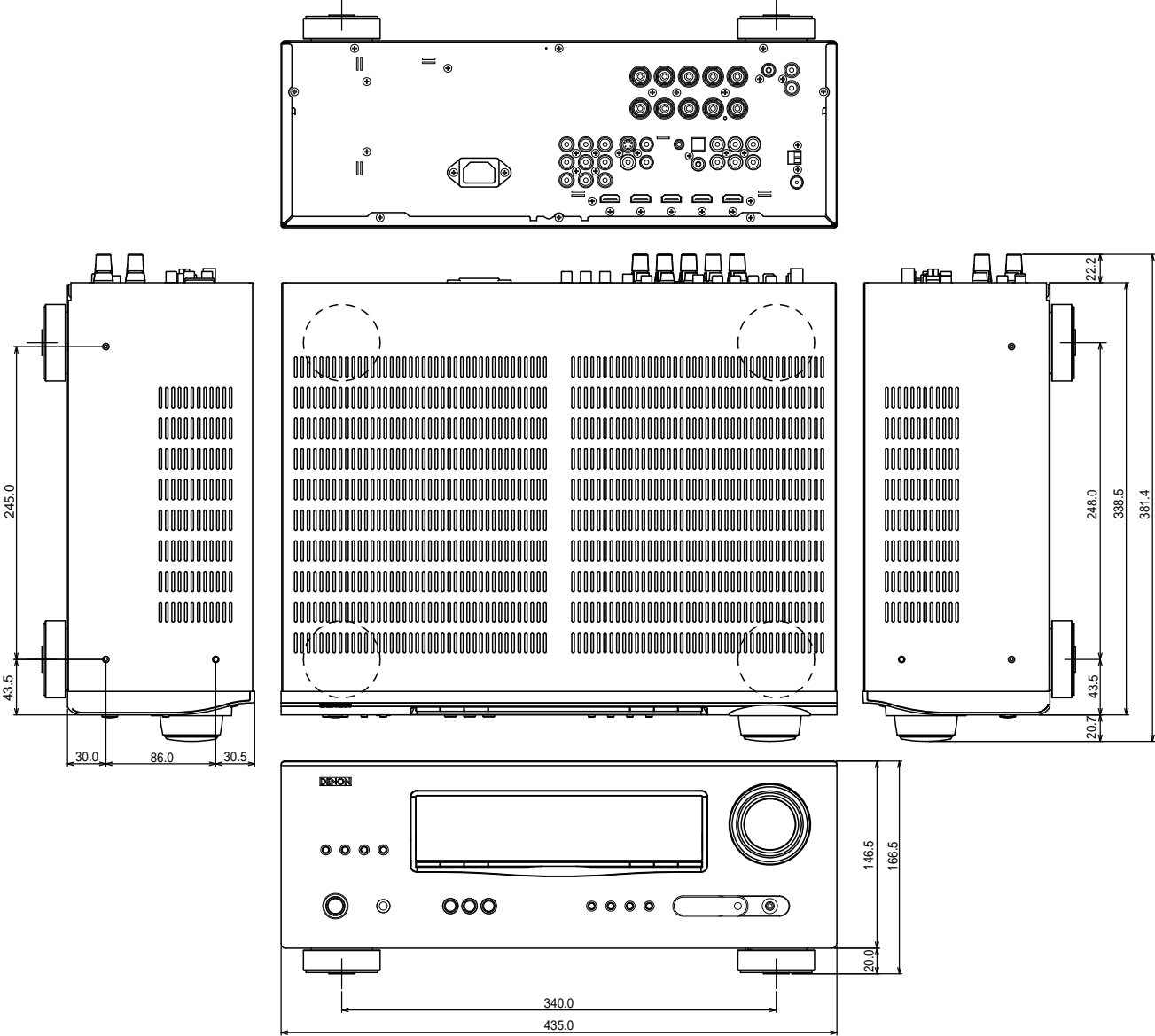

The illustration is AVR-1311 model.

CAUTION IN SERVICING

Initializing AV SURROUND RECEIVER

AV SURROUND RECEIVER initialization should be performed when the μ com, peripheral parts of μ com, and Digital P.W.B. are replaced.

1. Turn off the power using ON/STANDBY button.
2. Press ON/STANDBY button while simultaneously pressing SURROUND MODE ◀ and SURROUND MODE ▶ buttons.
3. Check that the entire display is flashing with an interval of about 1 second, and release your fingers from the 2 buttons and the microprocessor will be initialized.

Note:

- If step 3 does not work, start over from step 1.
- All user settings will be lost and this factory setting will be recovered when this initialization mode. So make sure to memorize your setting for restoring after the initialization.

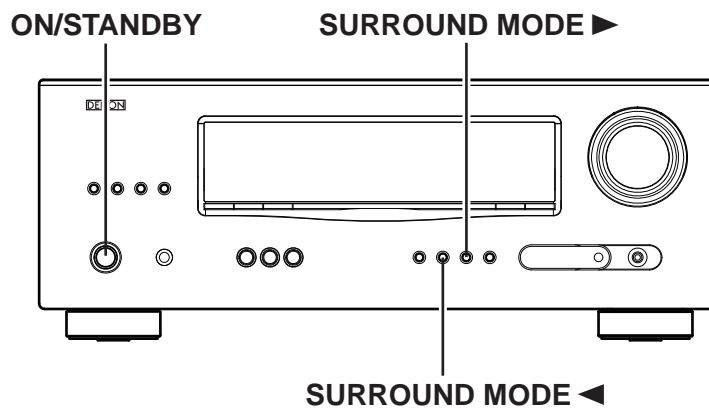

Service Jigs

When you update the firmware, you can use the following JIG (RS232C to internal connector conversion adapter with 4P FFC cable kit). Please order to Denon Official Service Distributor in your region if necessary.

8U-210100S : WRITING KIT : 1 Set
606050028012P : 7P FFC(1.0) L-240 : 1 Set
(Refer to "VERSION UPGRADE PROCEDURE OF FIRMWARE".)

DISASSEMBLY

- Disassemble in order of the arrow of the figure of following flow.
 - In the case of the re-assembling, assemble it in order of the reverse of the following flow.
 - In the case of the re-assembling, observe "attention of assembling" it.
 - If wire bundles are untied or moved to perform adjustment or parts replacement etc., be sure to rearrange them neatly as they were originally bundled or placed afterward.
- Otherwise, incorrect arrangement can be a cause of noise generation.

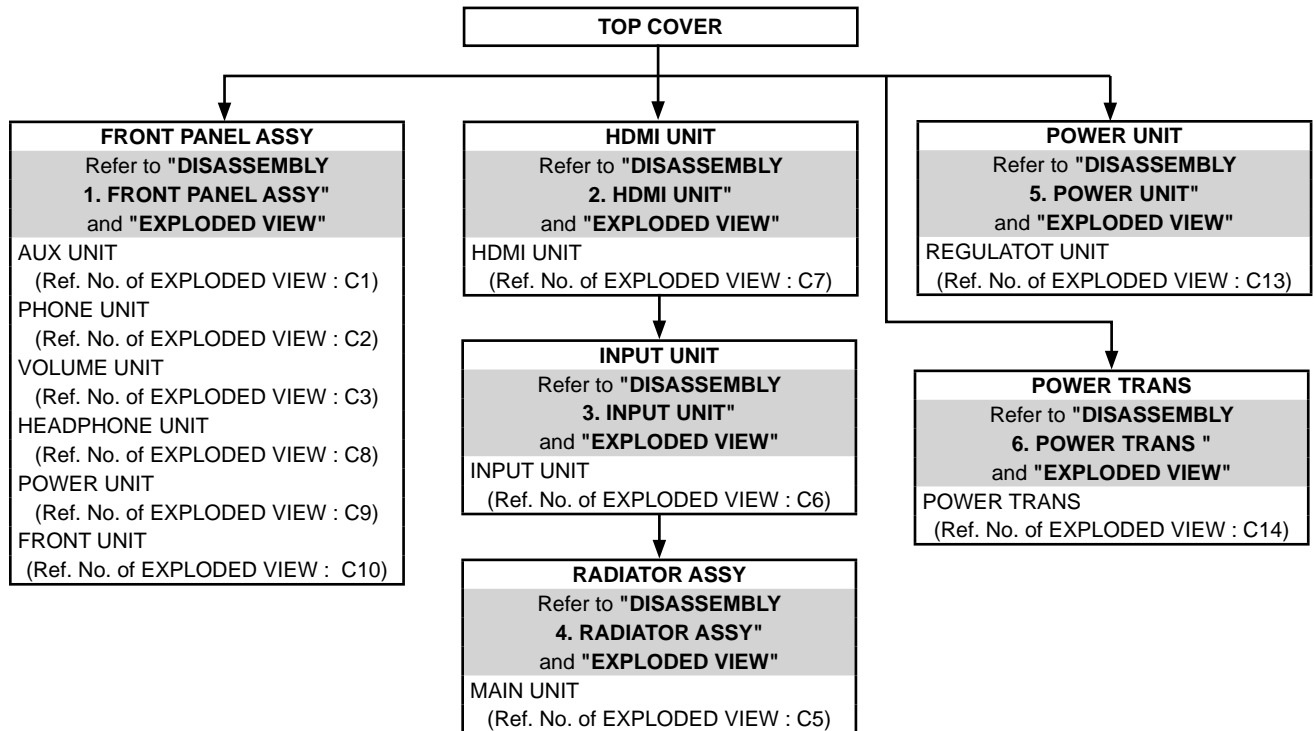

About the photos used for descriptions in the "DISASSEMBLY" section.

- The direction from which the photographs used herein were photographed is indicated at "Direction of photograph: ***" at the left of the respective photographs.
- Refer to the table below for a description of the direction in which the photos were taken.
- Photographs for which no direction is indicated were taken from above the product.

The viewpoint of each photograph (Photografy direction)

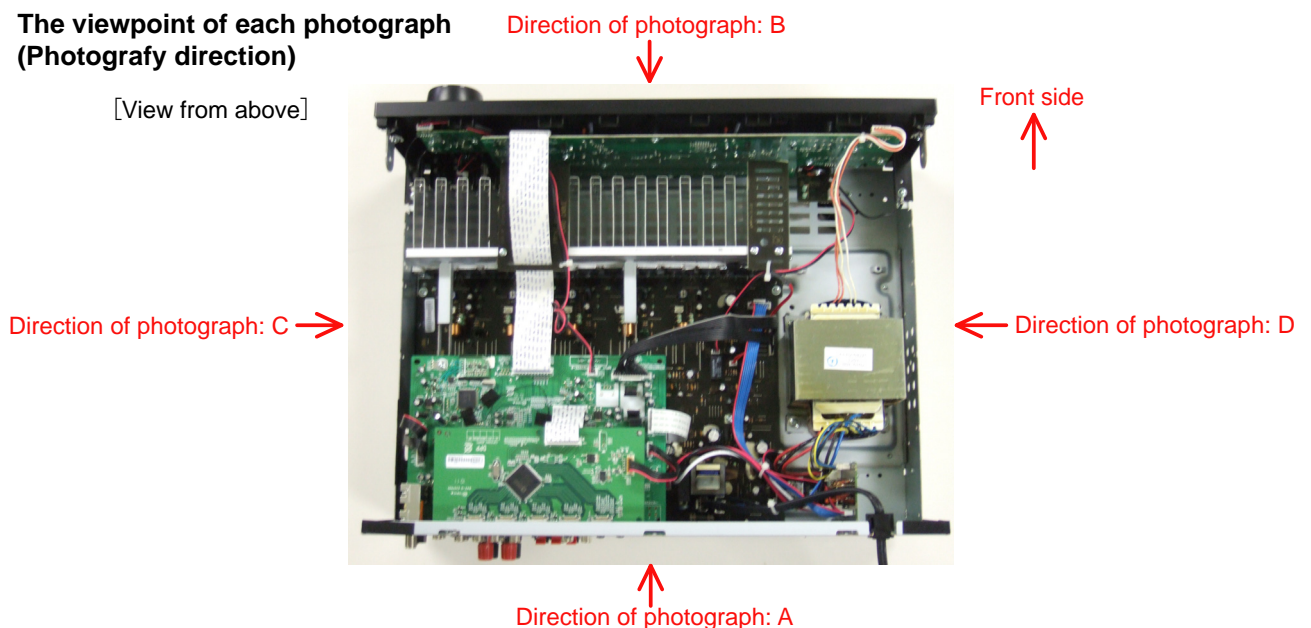

1. FRONT PANEL ASSY

Proceeding : **TOP COVER** → **FRONT PANEL ASSY**

(1) Remove the screws.

View from bottom

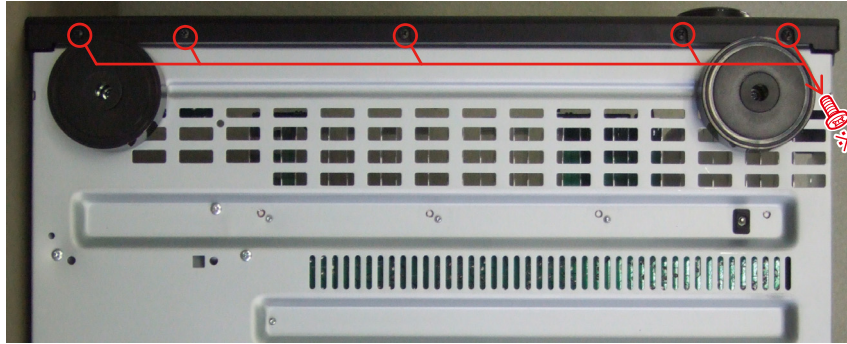

(2) Cut the wire clamp band, then disconnect the connector wires and FFC cable. Remove the screws.

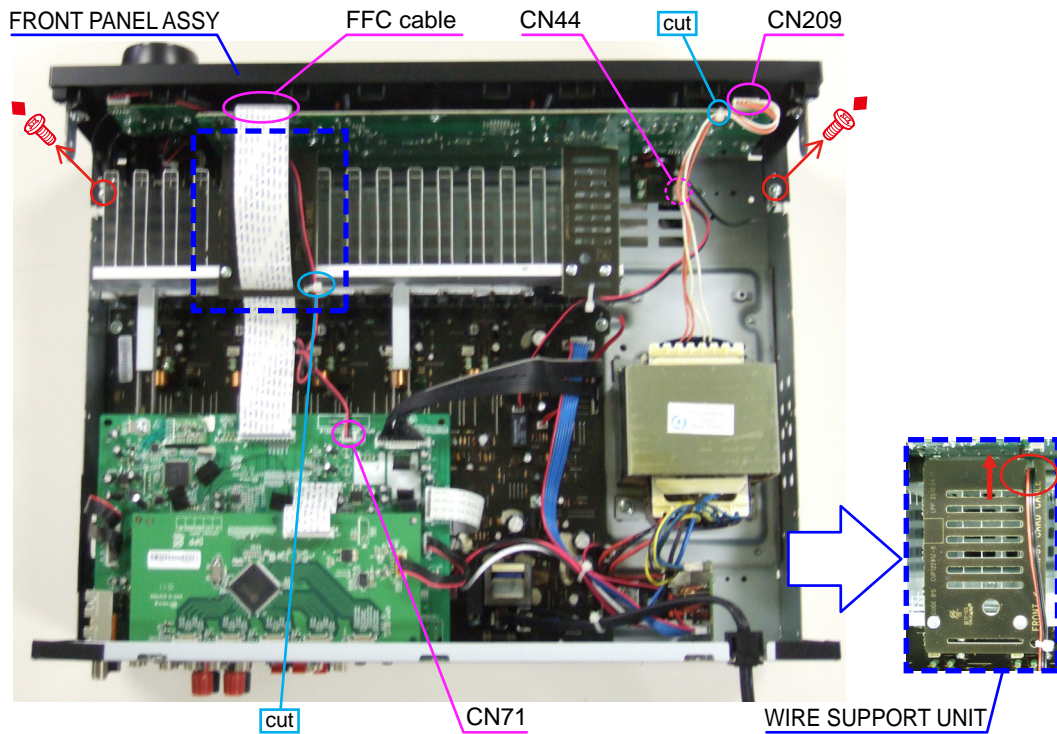

(3) Remove the screws.

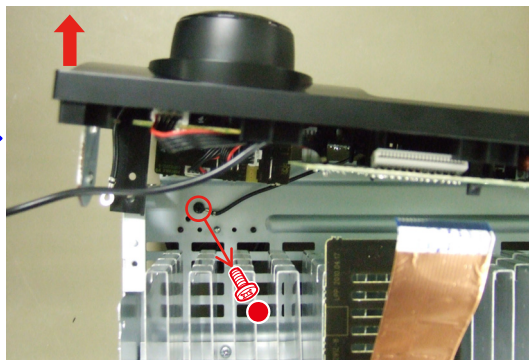
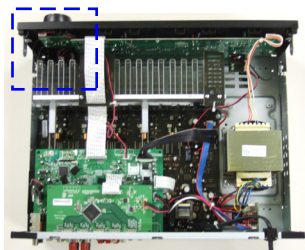

Please refer to "EXPLODED VIEW" for the disassembly method of each P.W.B included in FRONT PANEL ASSY.

2. HDMI UNIT

Proceeding : **TOP COVER** → **HDMI UNIT**

(1) Remove the screws.

Direction of photograph: A

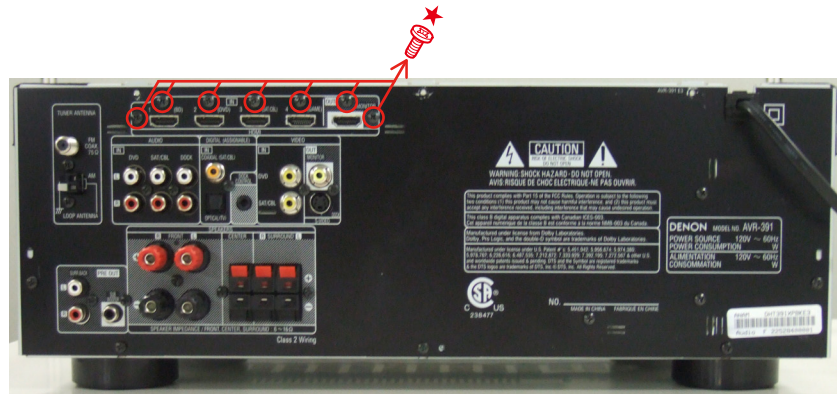

(2) Disconnect the connector wire and FFC cable.

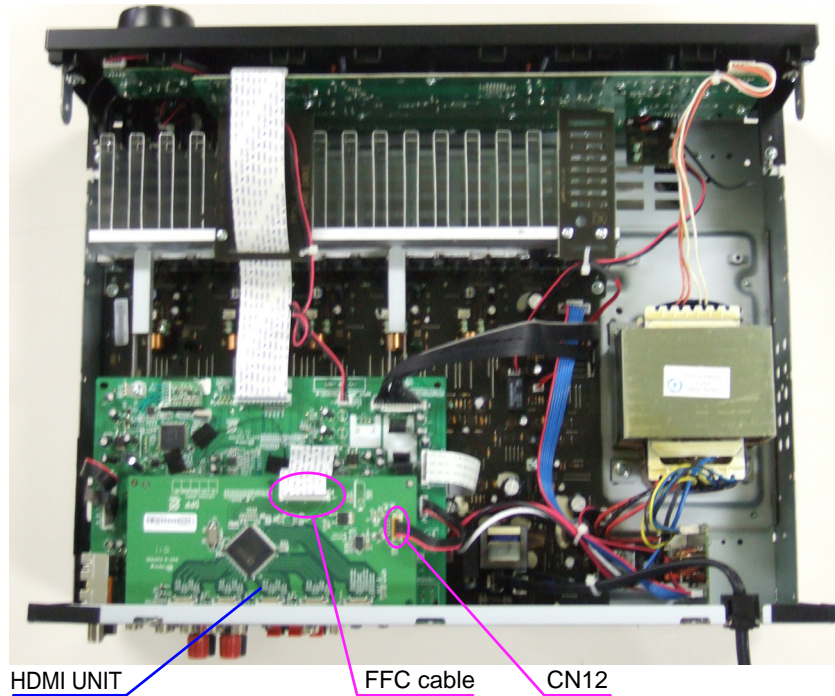

3. INPUT UNIT

Proceeding : **TOP COVER** → **HDMI UNIT** → **INPUT UNIT**

(1) Remove the screws.

Direction of photograph: A



(2) Disconnect the connector wires and FFC cables, then remove the screws.

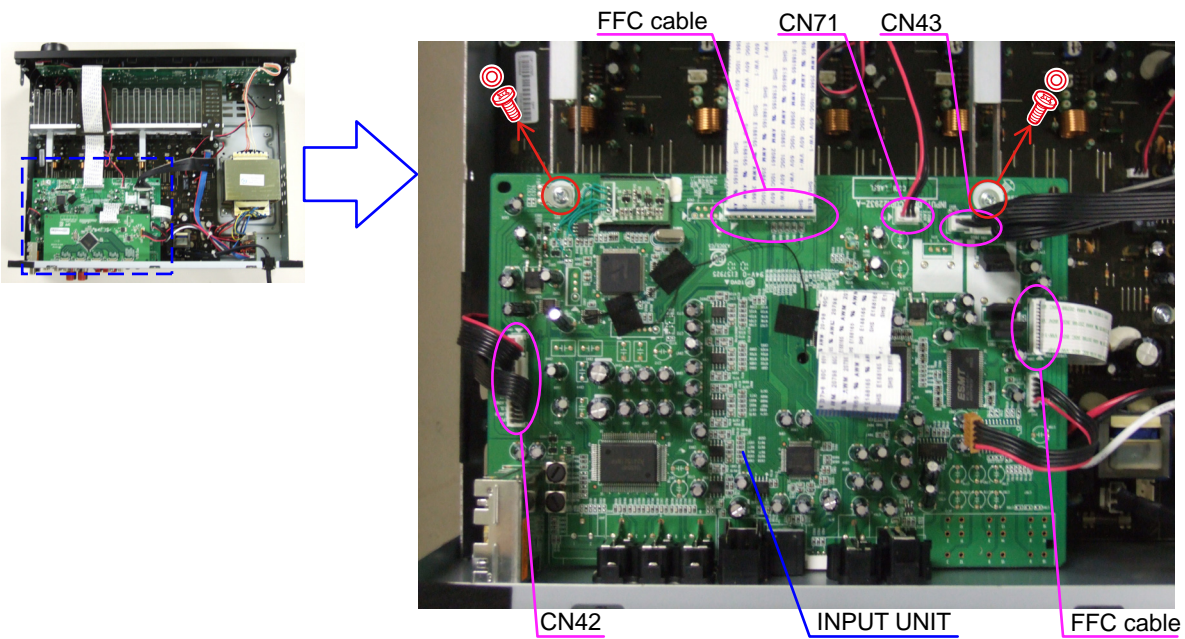

4. RADIATOR ASSY

Proceeding : **TOP COVER** → **HDMI UNIT** → **INPUT UNIT** → **RADIATOR ASSY**

(1) Remove the screws.

Direction of photograph: A



(2) Disconnect the connector wires, then remove the screws.

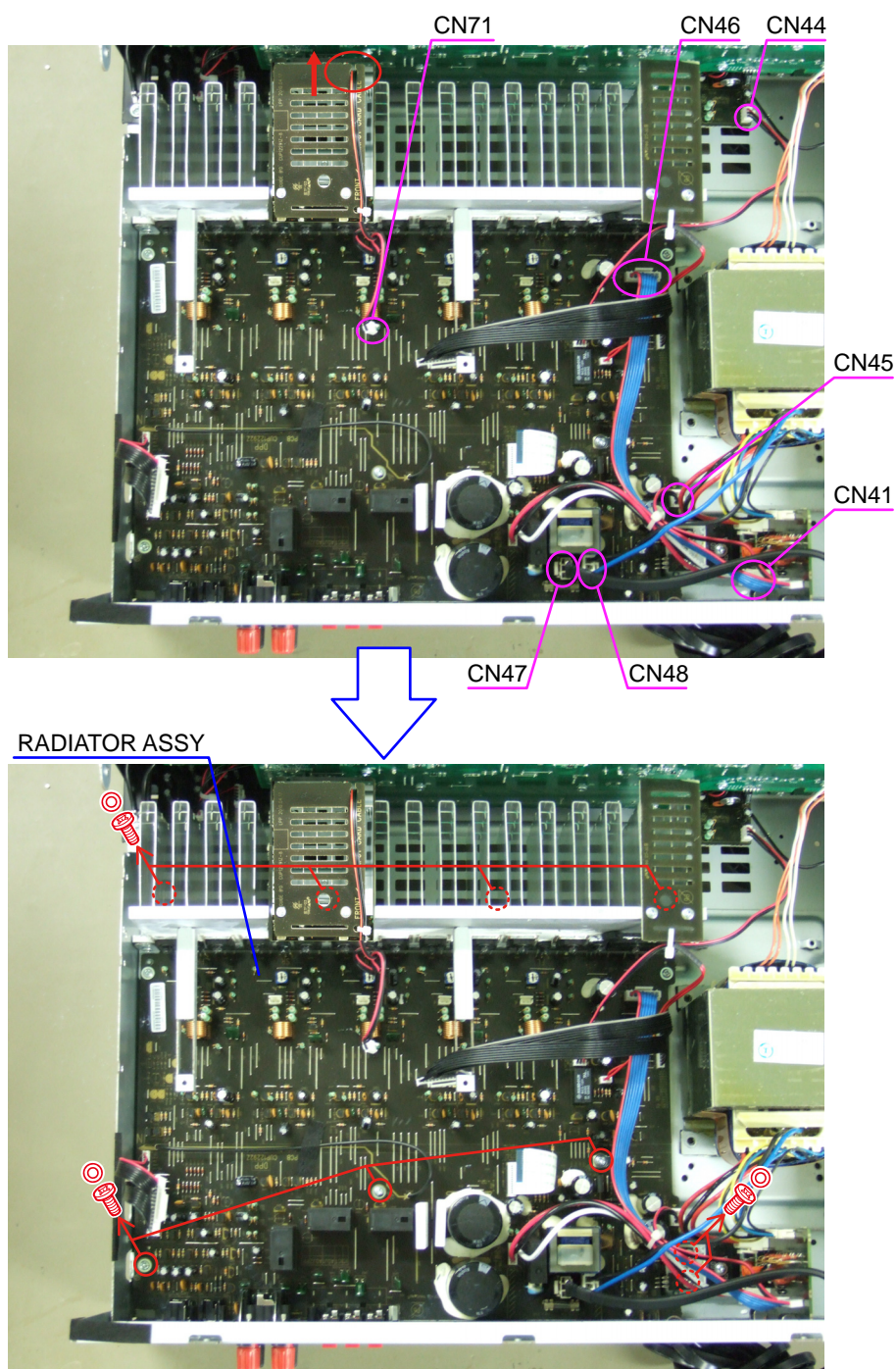

(3) Remove the RADIATOR ASSY from the main unit.

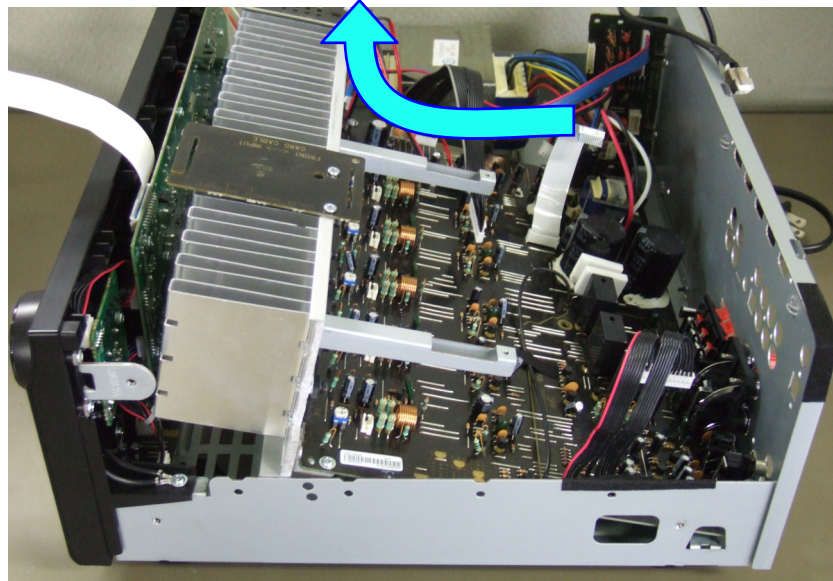

Direction of photograph: C

Please refer to "EXPLODED VIEW" for the disassembly method of each P.W.B included in RADIATOR ASSY.

5. POWER UNIT

Proceeding : **TOP COVER** → **POWER UNIT**

Please refer to "EXPLODED VIEW" for the disassembly method of POWER UNIT.

6. POWER TRANS

Proceeding : **CABINET TOP** → **TRANS MAIN**

Please refer to "EXPLODED VIEW" for the disassembly method of POWER TRANS.

SPECIAL MODE

Special mode setting button

※ Press the ON/STANDBY button to turn on while pressing both buttons A and B at the same time.

Mode	Button A	Button B	Contents
μcom/DSP Version display mode	STATUS	DIMMER	Firmware versions such as Main, DSP are displayed in the FL display. Errors are displayed when they occur. (Refer to page 14.)
Initialization mode	SURROUND MODE ◀	SURROUND MODE ▶	Backup data initialization is carried out. (Refer to page 6.)
Mode for switching tuner frequency step	SURROUND MODE ◀	RESTORER	---E2 model only--- Change tuner frequency step to AM9k/FM50kHz STEP or AM:10k/FM:200kHz.
Mode for preventing remote control acceptance	SURROUND MODE ◀	STATUS	Operations using remote control are rejected. "REMOTE LOCK:ON" is displayed in FL display. (Mode cancellation: Turn off power and execute the same button operations as when performing setup.)

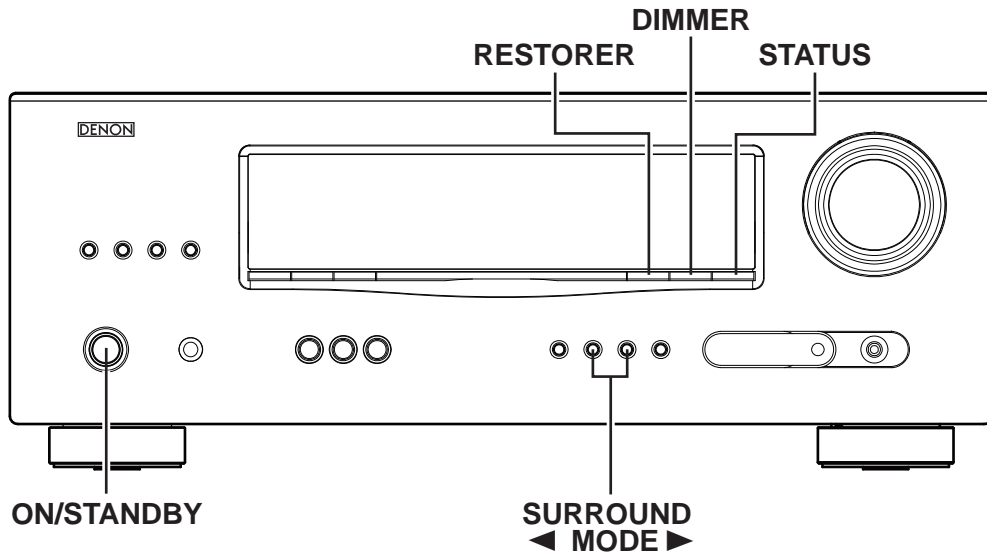

1. μ com/DSP Version display mode

1.1. Operation specifications

μ com/DSP version display mode:

When started up, the version information is displayed.

Starting up:

With the "DIMMER" and "STATUS" buttons pressed, press the "ON/STANDBY" button to turn the power on.

Now, press the "STATUS" button to the display the 2nd item information on the FL Display.

1.2. Display Order

Model name → Main- μ com version → DSP version → iPod Dock version (Connecting iPod Dock)

Display		State
Model name	AVR-391 E3 model	AVR391 E3
	AVR-1311 E2 model	AVR1311 E2
	AVR-391 EA model	AVR391 EA
	AVR-1311 E1C model	AVR1311 E1C
Main- μ com version		Main **.*
DSP version		DSP *.*.*
iPod Dock (ASD-1R/11R)		Dock Ver ***.*
iPod Dock (ASD-3/51)		Dock :I*****

Cleared of mode:

Press the "ON/STANDBY" button to turn the power off.

1.3. Error display

See the following table for each "Error information" display and its contents (status).

Condition	-	State
DSP NG	When DSP boot, executing DSP reset makes to becomes error.	DSP ERROR 01
DSP OK		(No error display, version display only)

ABOUT REPLACE THE MICROPROCESSOR WITH A NEW ONE

When replaced of the U-PRO (Microprocessor) or the Flash ROM, confirm contents of the following.

PWB Name	Ref. No.	Description	After replaced	Remark
DIGITAL	IC91	T5CN5	B	SOFTWARE: Main
DIGITAL	IC82	ST25VF080B-50-4C-S2AF	B	SOFTWARE: DSP ROM

After replaced

A : Mask ROM (With software). No need write-in of software to the microprocessor.

B : Flash ROM (With software). Usually, no need write-in of software. But, when the software was updated, you should be write-in of the new software to the microprocessor or flash ROM. Please check the software version.

C : Empty Flash ROM (Without software). You should be write-in of the software to the microprocessor or flash ROM. Refer to "Update procedure" or "writing procedure", when you should be write-in the software.

VERSION UPGRADE PROCEDURE OF FIRMWARE

1. Preparations

-Before starting the operation-

- (1) Personal Computer (Installed "BootTool_M330(Writing program).exe").
- (2) RS-232 cable (9P (Male), Straight).
- (3) 8U-210100S Writing Kit.
- (4) 606050028012P / 7P FFC(1.0) L=240.

-Connection of the AV receiver-

- (1) Confirm the power on/off switch of the AV receiver is turning off.
- (2) Connect the update terminal of AV receiver with the "Writing Kit".
(Refer to figure below for the connection of the 7P FFC cable.)
- (3) Connect the RS-232C cable from PC with the "Writing Kit".

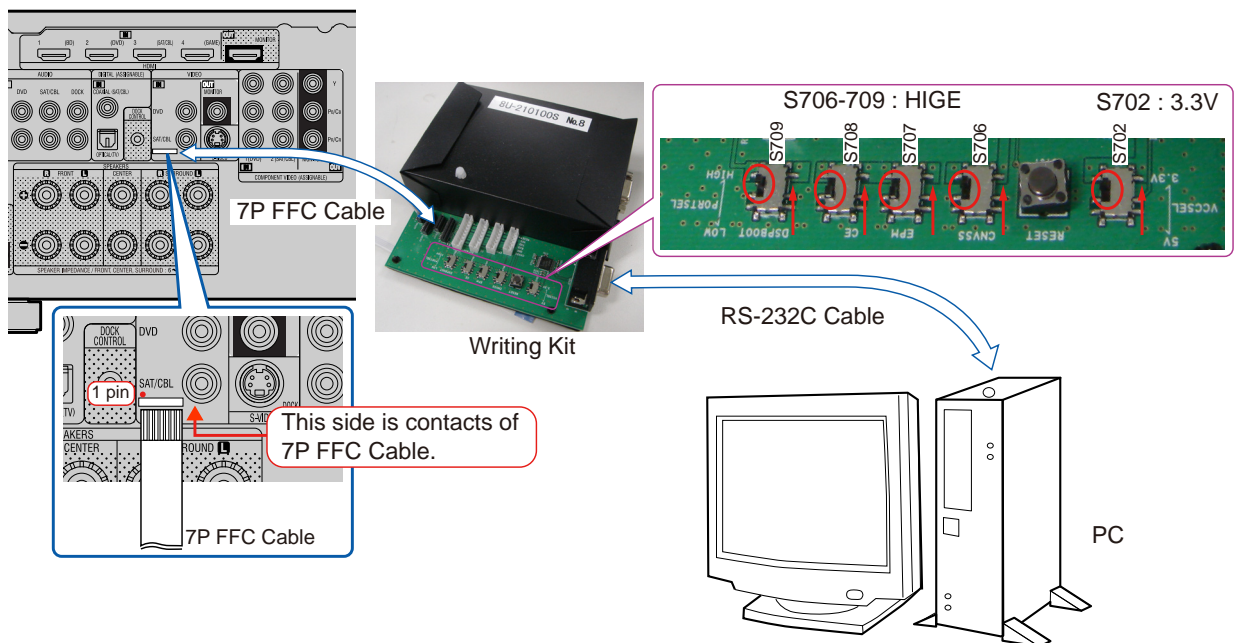

2. UPDATE FIRMWARE

- (1) Connect the update terminal of AV receiver with the "Writing Kit".
- (2) Set the switch of "Writing Kit" (Refer to the table below).

DSPBOOT	CE	EPM	CNVSS
H	H	H	H

- (3) Press the "ON/STANDBY" button to turn the power on of AV receiver.
- (4) Set the switch of "Writing Kit" (Refer to the table below).

DSPBOOT	CE	EPM	CNVSS
H	H	L	H

- (5) Press the "RESET" switch of "Writing Kit".
- (6) Run the "BootTool_M330(Writing program).exe" on desktop of PC.



BootTool_M330(Writing program).exe

- (7) Click the "Connect" button.

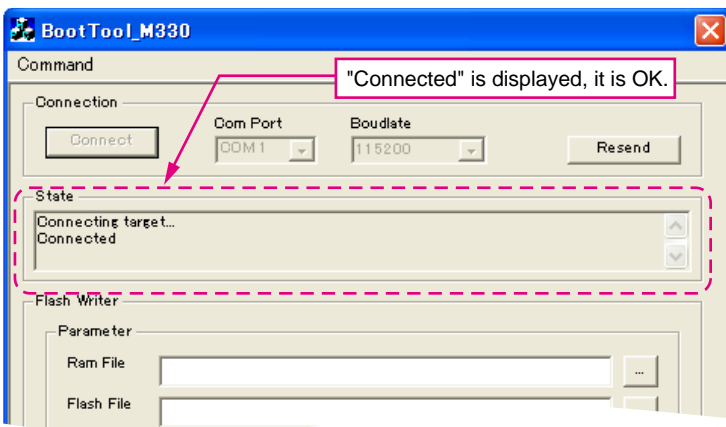
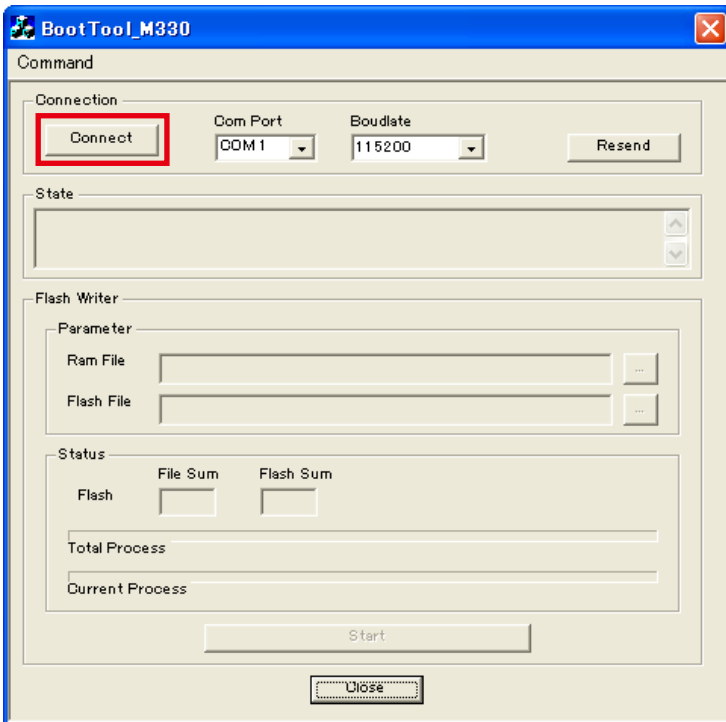

DSP SF1

(8) Choose Ram File(OnBoard_M330.s32).

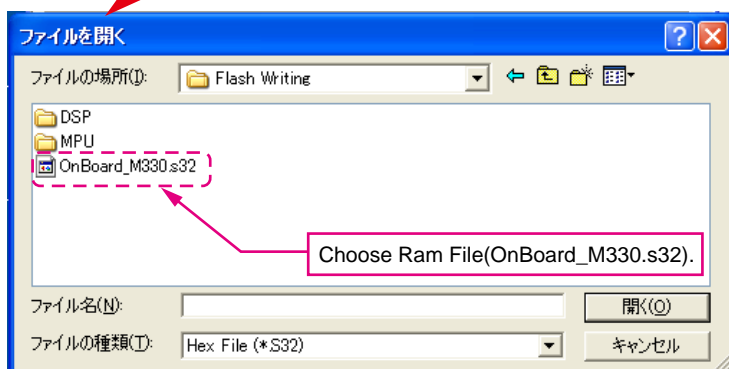
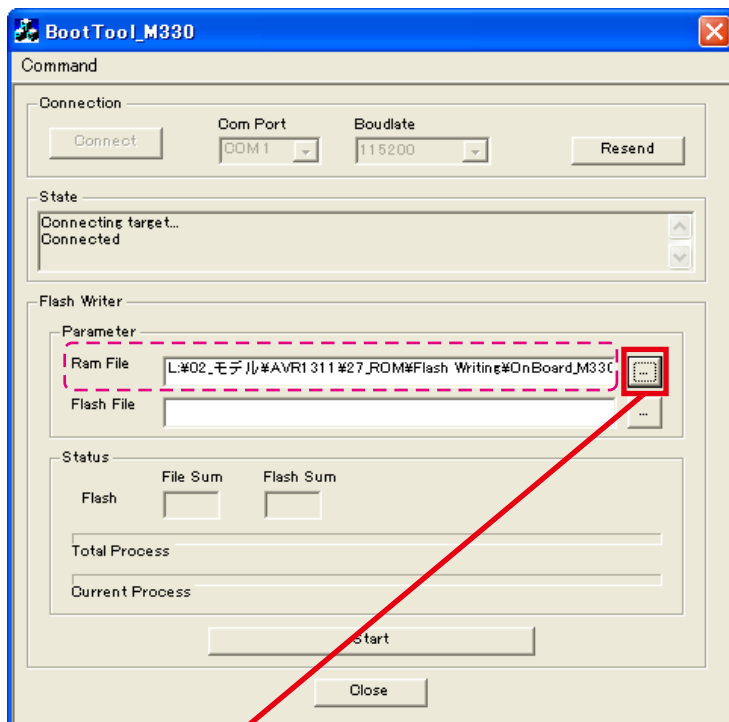

(9) Choose Flash File(DSP : SF1).

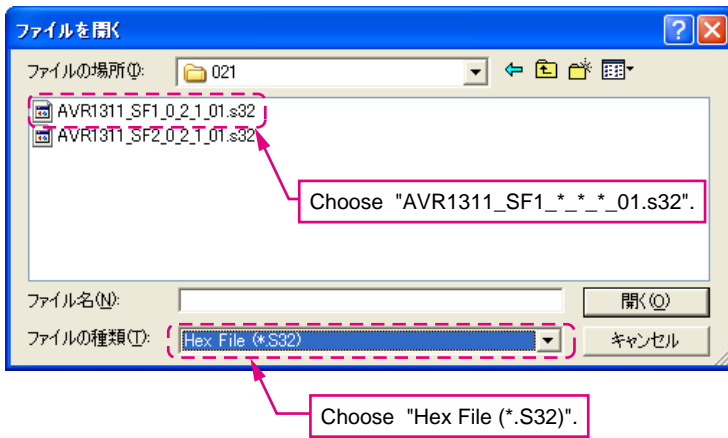
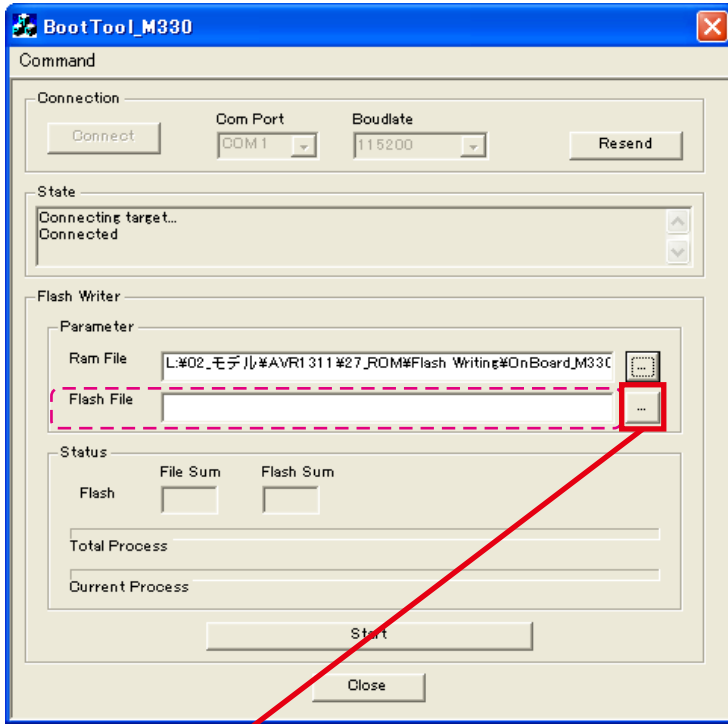

(10) Click the "Start" button.

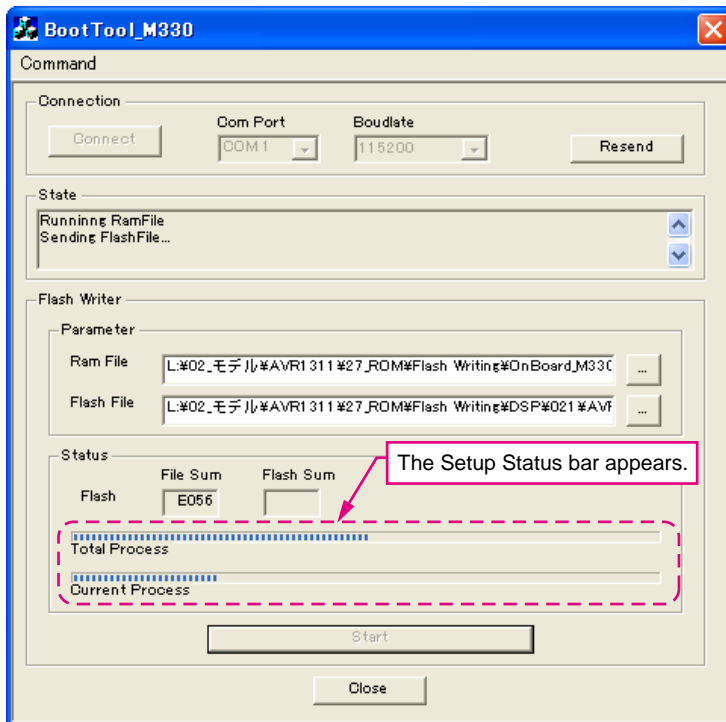
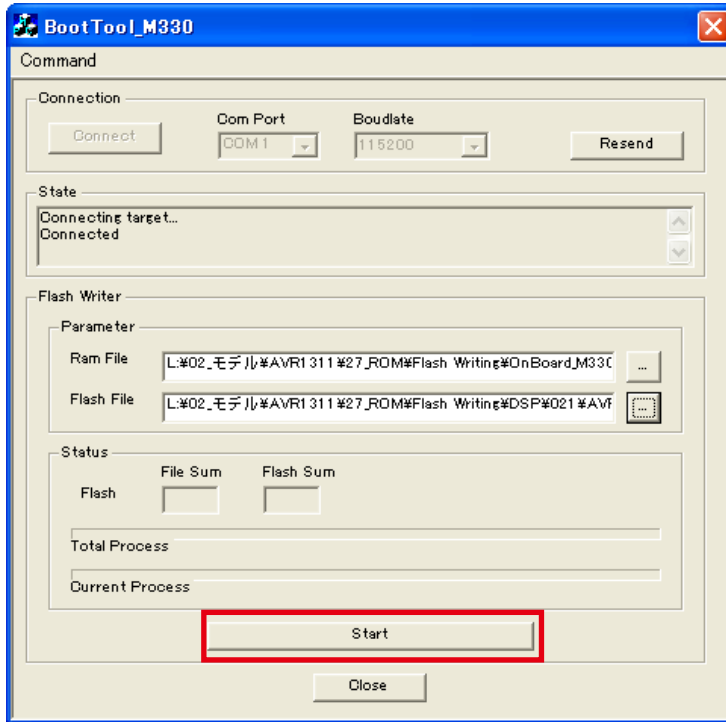

(11) "Finished!!" is displayed. Click the "OK" button.

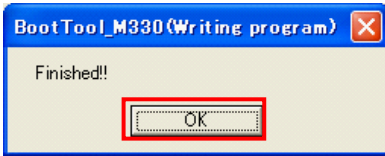

(12) Set the switch of "Writing Kit" (Refer to the table below).

DSPBOOT	CE	EPM	CNVSS
H	H	H	H

(13) Press the "RESET" switch of "Writing Kit".

(14) AV receiver is power on and starts update of DSP1.

(15) "Write Completed" is displayed in the FL tube.

(16) Set the switch of "Writing Kit" (Refer to the table below).

DSPBOOT	CE	EPM	CNVSS
H	H	L	H

(17) Press the "RESET" switch of "Writing Kit".

DSP SF2

(18) Click the "Resend" button.

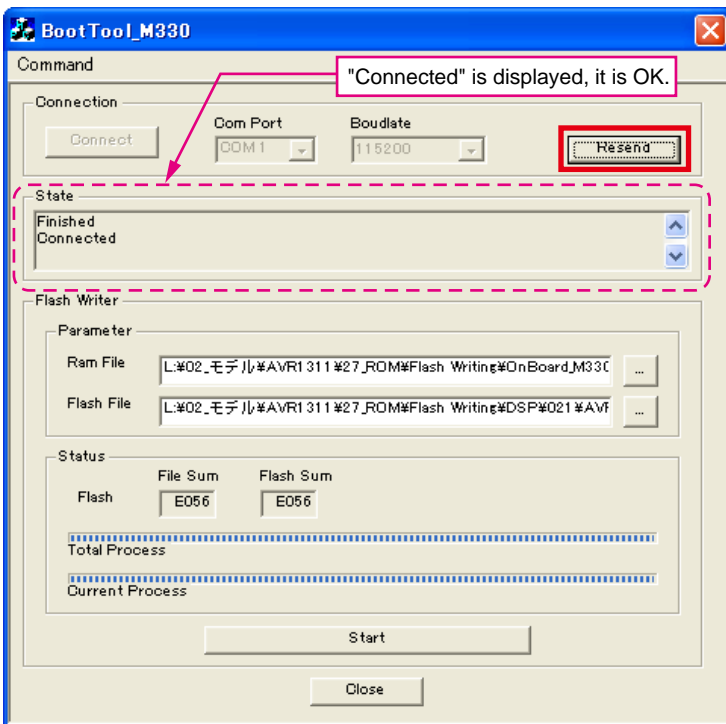

(19) Choose Flash File(DSP : SF2).

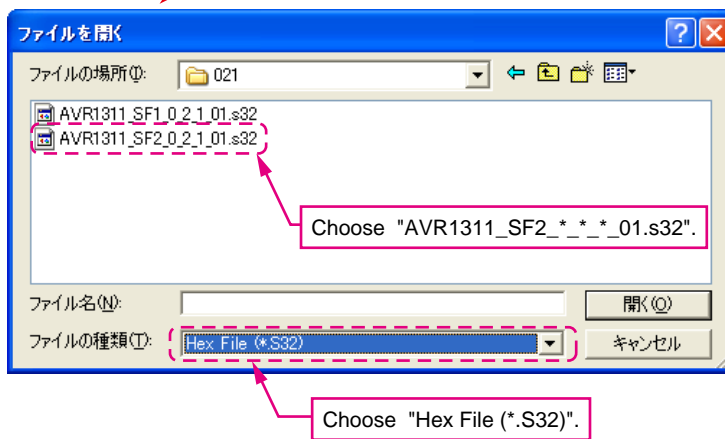
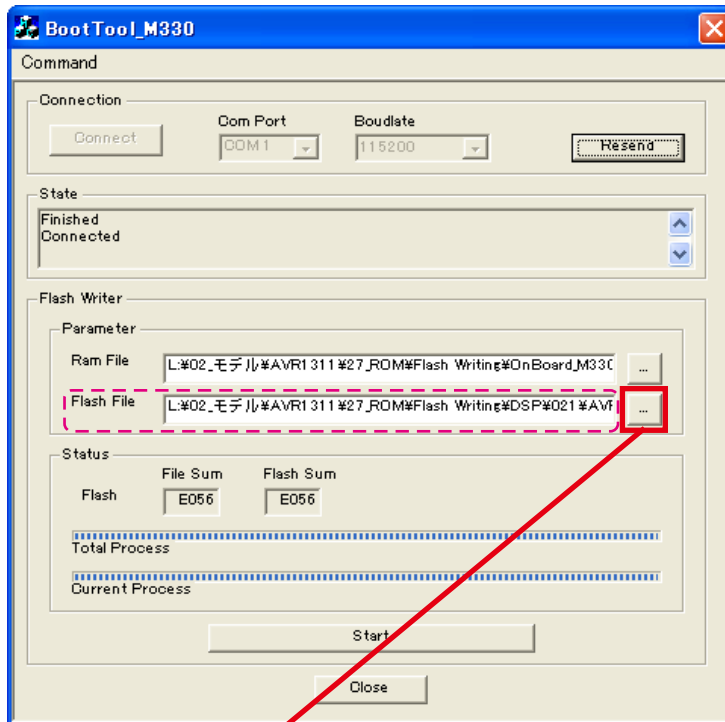

(20) Click the "Start" button.

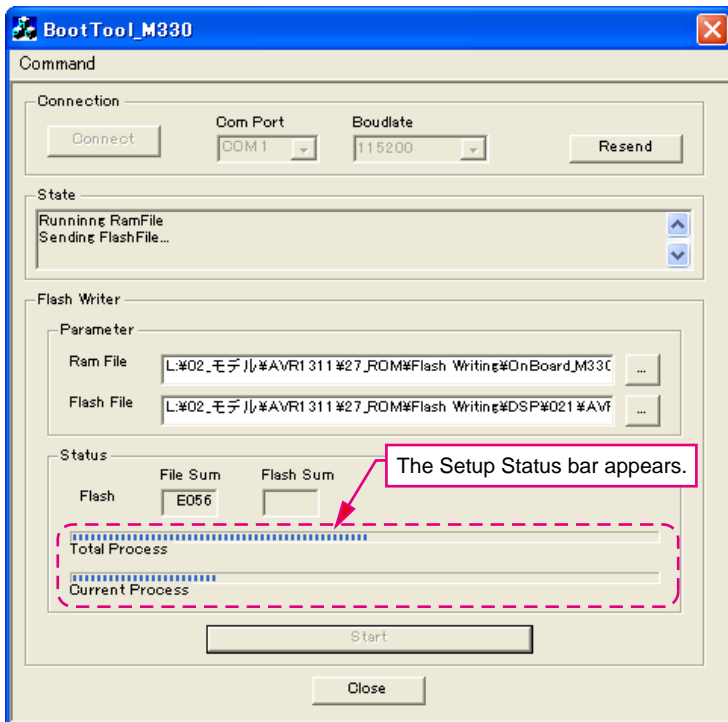
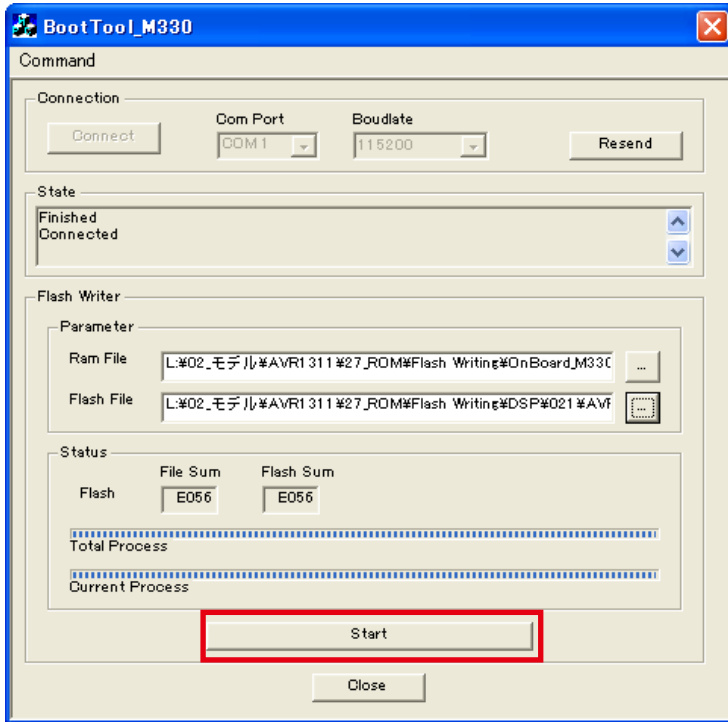

(21) "Finished!!" is displayed. Click the "OK" button.

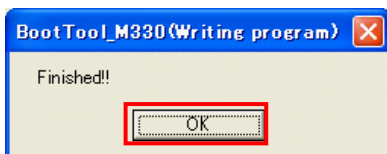

(22) Set the switch of "Writing Kit" (Refer to the table below).

DSPBOOT	CE	EPM	CNVSS
H	H	H	H

(23) Press the "RESET" switch of "Writing Kit".

(24) AV receiver is power on and starts update of DSP2.

(25) "Write Completed" is displayed in the FL tube.

(26) Set the switch of "Writing Kit" (Refer to the table below).

DSPBOOT	CE	EPM	CNVSS
H	H	L	H

(27) Press the "RESET" switch of "Writing Kit".

MAIN

(28) Click the "Resend" button.

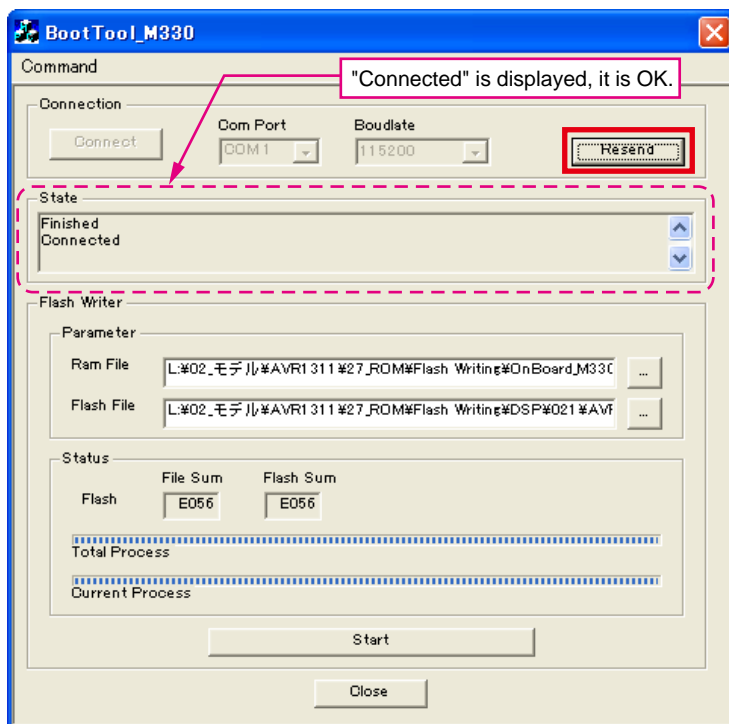

(29) Choose Flash File(MAIN).

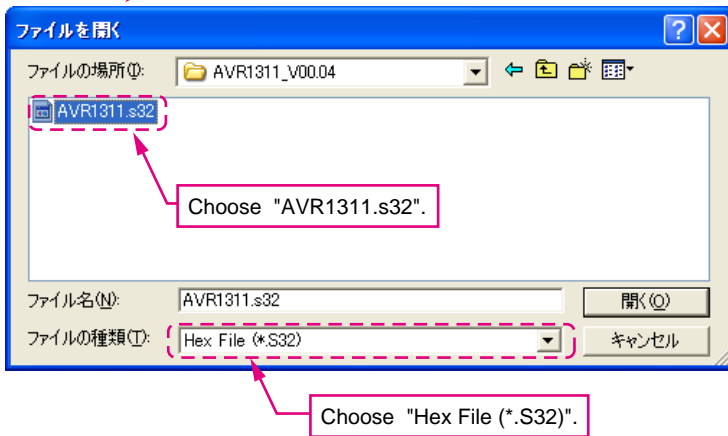
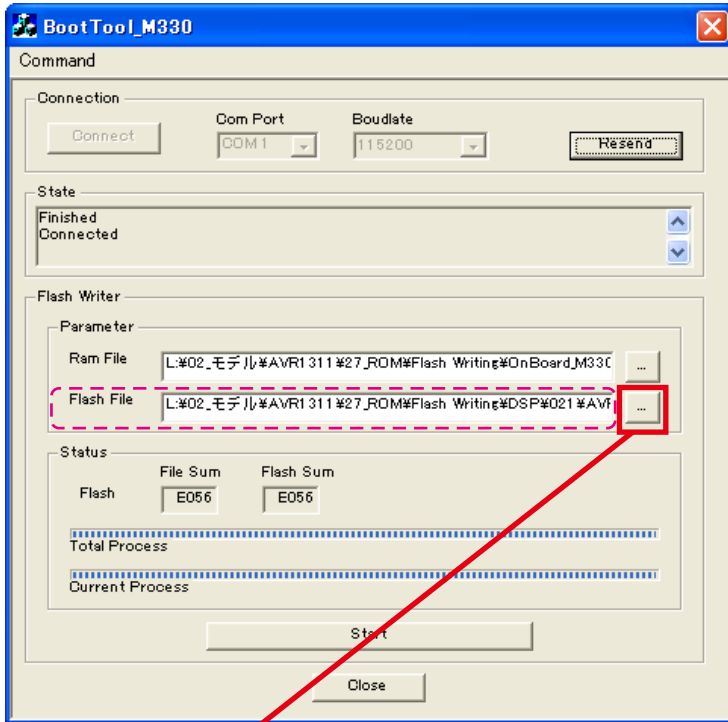

(30) Click the "Start" button.

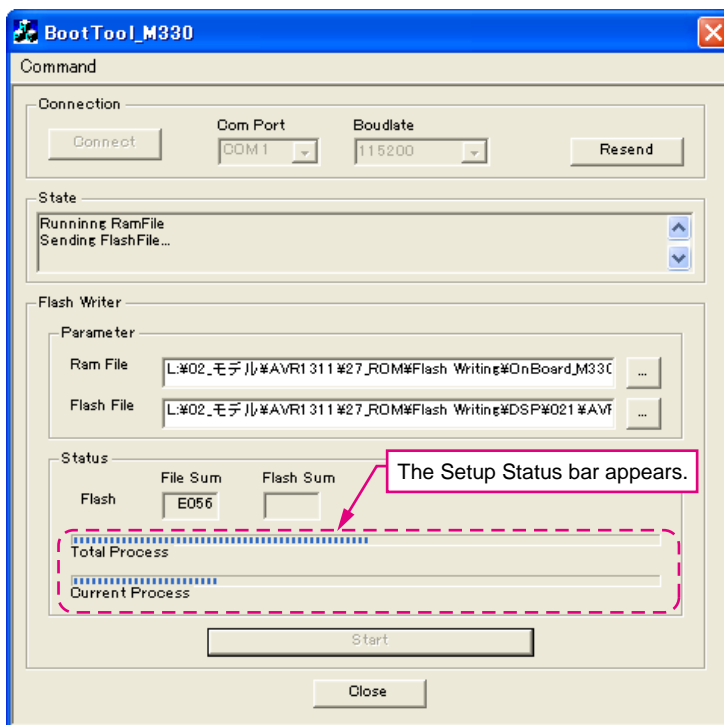
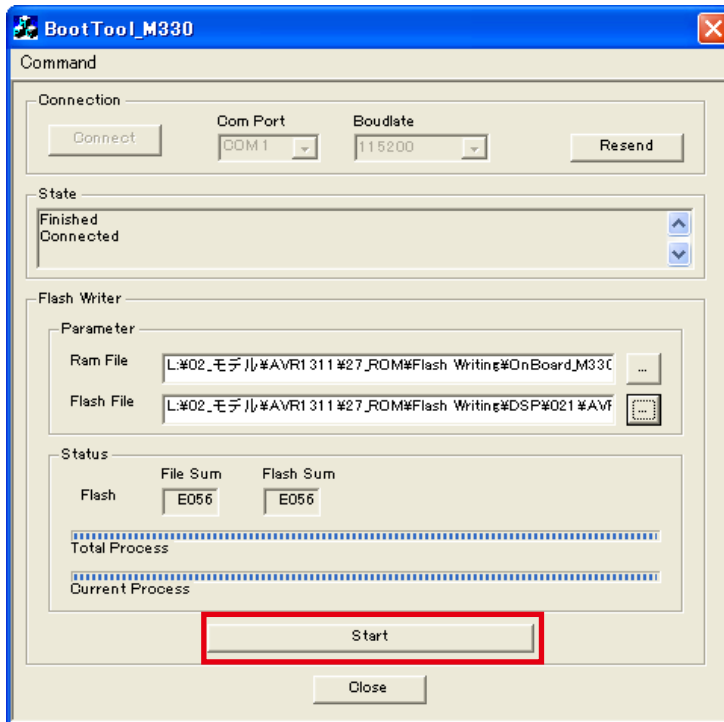

(31) "Finished!!" is displayed. Click the "OK" button.

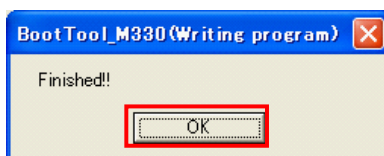

(32) Set the switch of "Writing Kit" (Refer to the table below).

DSPBOOT	CE	EPM	CNVSS
H	H	H	H

(33) Press the "RESET" switch of "Writing Kit".

(34) Initializing.

1. Turn off the power using ON/STANDBY button.
2. Press ON/STANDBY button while simultaneously pressing SURROUND MODE ◀ and SURROUND MODE ▶ buttons.
3. Check that the entire display is flashing with an interval of about 1 second, and release your fingers from the 2 buttons and the microprocessor will be initialized.

Note: •If step 3 does not work, start over from step 1.
 •All user settings will be lost and this factory setting will be recovered when this initialization mode.
 So make sure to memorize your setting for restoring after the initialization.

3. Notice:

Please keep the following notice for firmware update.

- (a) Keep the PC environment
- (b) Avoid the communication cable from the electrical noise source.
(e.g. telephone cable, AC line, a fluorescent light)
- (c) Don't remove cable during update.
- (d) Don't turn off the power during update.
- (e) Don't run other PC application during update.
- (f) Stop the resident program on PC (Virus checker and System check utility, etc)
- (g) Stop the screen saver on PC.
- (h) Stop the power save ability on PC.
- (i) In case of laptop PC, Use the AC adaptor.

Confirming the firmware's number after upgraded

After completion of the updating operation, the new version number can confirmed by starting up the AVR1311 or AVR391 according to the following procedure.

With the following operation, the AVR1311 or AVR391 can be set to the Flash ROM Version-Number Confirmation mode. Turn on power switch while simultaneously pressing "DIMMER" and "STATUS" buttons on the front panel. Every time the "STATUS" button is pressed, version number of the Model, Main, DSP, ... are indicated on the front panel section in the following order.

Depression	Button	Name	Remarks
1	STATUS	Model Name	AVR1311 or AVR391 **
2	STATUS	Main CPU	Main: **. **
3	STATUS	DSP ROM	DSP. *. **

ADJUSTMENT

Audio Section

Idling Current

Required measurement equipment: DC Voltmeter

1. Preparation

- (1) Avoid direct blow from an air conditioner or an electric fan, and adjust the unit at normal room temperature 15 °C ~ 30 °C.
- (2) Presetting
 - POWER (Power source switch) OFF
 - SPEAKER (Speaker terminal) No load
(Do not connect speaker, dummy resistor, etc.)

2. Adjustment

- (1) removed top cover and set VR41(FL),VR45(FR),VR42(C),VR44(SL),VR43(SR), on Main Amp. Unit at fully counterclockwise position.
- (2) Connect DC Voltmeter to test points (Front-Lch:CN51,Front-Rch:CN55,CENTERch:CN53, Surround-Lch:CN52,Surround-Rch:CN54).
- (3) Connect power cord to AC Line, and turn power switch "ON".
- (4) Presetting.
MASTER VOLUME : "---" counterclockwise (Ω min.)
SPEAKER (Speaker terminal) : No load
(Do not connect speaker, dummy resistor, etc.)
FUNCTION : DVD
- (5) Within 2 minutes after the power on, turn VR41 clockwise (Ω) to adjust the TEST POINT voltage to $1.5 \text{ mV} \pm 0.5 \text{ mV DC}$.
- (6) After 10 minutes from the preset above, turn VR401 to set the voltage to $2.0 \text{ mV} \pm 0.5 \text{ mV DC}$.
- (7) Adjust the Variable Resistors of other channels (VR42-VR45) in the same way.

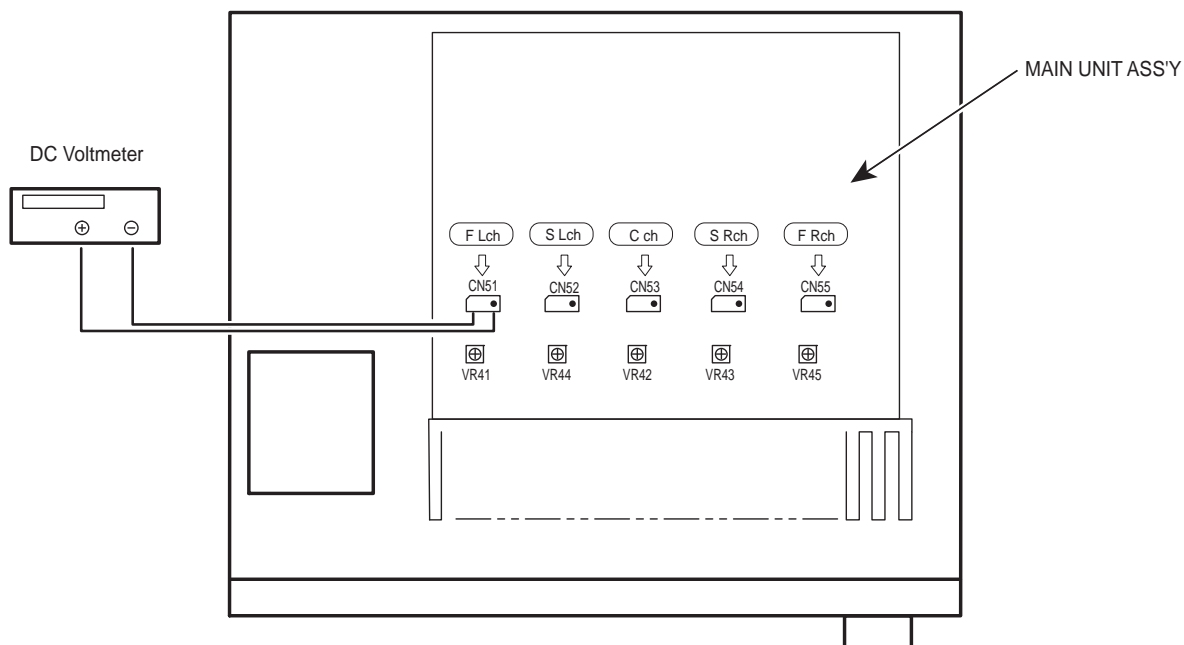

SURROUND MODES AND PARAMETERS

Symbols in the table

○ This indicates the audio output channels or surround parameters that can be set.

⊙ This indicates the audio output channels. The output channels depend on the settings of "Speaker Config."

Surround mode	Channel output				Surround Parameter				
	Front L/R	Center	Surround L/R	Surround Back L/R	Subwoofer *2	Mode	D. Comp *3	DRC *4	LFE *5
DIRECT (2channel)	○				⊙ *2		○	○	
DIRECT (Multi-channel)	○	⊙	⊙	⊙ *1	○		○	○	○
STEREO	○				⊙		○	○	○
MULTI CH IN	○	⊙	⊙	⊙	⊙		○	○	○
DOLBY PRO LOGIC IIx	○	⊙	⊙	⊙	⊙	○	○	○	
DOLBY PRO LOGIC II	○	⊙	⊙	⊙	⊙	○	○	○	
DTS NEO6	○	⊙	⊙	⊙	⊙	○	○	○	
DOLBY DIGITAL	○	⊙	⊙	⊙	⊙	○	○	○	
DOLBY DIGITAL Plus	○	⊙	⊙	⊙	⊙	○	○	○	○
DOLBY TrueHD	○	⊙	⊙	⊙	⊙	○	○	○	○
DTS SURROUND	○	⊙	⊙	⊙	⊙	○	○	○	○
DTS 96/24	○	⊙	⊙	⊙	⊙	○	○	○	○
DTS-HD	○	⊙	⊙	⊙	⊙	○	○	○	○
DTS Express	○	⊙	⊙	⊙	⊙	○	○	○	○
MULTI CH STEREO	○	⊙	⊙	⊙	⊙ *2		○	○	○
VIRTUAL	○				○		○	○	○

*1 A signal for each channel contained in an input signal is output as audio.

*2 Only when "Mode" is set to "LFE+Main", sound is output from the subwoofer.

*3 This item can be selected when a Dolby Digital or DTS signal is played.

*4 This item can be selected when a Dolby TrueHD signal is played.

*5 This item can be selected when a Dolby Digital or DTS signal or DVD-Audio is played.

Surround mode	Surround Parameter							RESTORER # 7
	AFDM #6	S.Back	Subwoofer ○ *2	PRO LOGIC II/IIx Music mode only			NEOS Music mode only Center Image	
				Panorama	Dimension	Center Width		
DIRECT (2 channel)								
DIRECT (Multi-channel)								
STEREO								
MULTI CH IN	<input type="radio"/>	<input type="radio"/>	<input type="radio"/>	<input type="radio"/>	<input type="radio"/>	<input type="radio"/>		<input type="radio"/>
DOLBY PRO LOGIC IIx		<input type="radio"/>		<input type="radio"/>	<input type="radio"/>	<input type="radio"/>		<input type="radio"/>
DOLBY PRO LOGIC II		<input type="radio"/>		<input type="radio"/>	<input type="radio"/>	<input type="radio"/>		<input type="radio"/>
DTS NEO:6		<input type="radio"/>		<input type="radio"/>			<input type="radio"/>	<input type="radio"/>
DOLBY DIGITAL	<input type="radio"/>	<input type="radio"/>						<input type="radio"/>
DOLBY DIGITAL Plus	<input type="radio"/>	<input type="radio"/>						<input type="radio"/>
DOLBY TrueHD	<input type="radio"/>	<input type="radio"/>						<input type="radio"/>
DTS SURROUND	<input type="radio"/>	<input type="radio"/>						<input type="radio"/>
DTS 96/24	<input type="radio"/>	<input type="radio"/>						<input type="radio"/>
DTS-HD	<input type="radio"/>	<input type="radio"/>						<input type="radio"/>
DTS Express	<input type="radio"/>	<input type="radio"/>						<input type="radio"/>
MULTI CH STEREO		<input type="radio"/>						<input type="radio"/>
VIRTUAL								<input type="radio"/>

*2 Only when "Mode" is set to "LFE+Main", sound is output from the subwoofer.

*6 This item can be selected when a Dolby Digital or DTS or DVD-Audio signal is played.

*7 This item can be set when the input signal is analog, PCM 48 kHz or 44.1 kHz.

Symbols in the table

- This indicates the default surround mode.
- ⊙ This indicates the surround mode that is fixed when "AFDM" is set to "ON".
- This indicates the selectable surround mode.

Surround mode	NOTE	Input signal types and formats															
		ANALOG		PCM		DTS-HD		DTS EXPRESS		DTS		DOLBY		DOLBY DIGITAL			
		LINEAR PCM (multi ch)	LINEAR PCM (2ch)	DTS-HD Master Audio	DTS-HD High Resolution Audio	DTS EXPRESS	DTS ES DSCR (With Flag)	DTS ES MTRX (With Flag)	DTS (5.1ch)	DTS 96/24	DOLBY TrueHD	DOLBY DIGITAL Plus	DOLBY DIGITAL EX (With Flag)	DOLBY DIGITAL EX (With no Flag)	DOLBY DIGITAL (5.1/5.4ch)	DOLBY DIGITAL (4/3ch)	DOLBY DIGITAL (2ch)
DTS SURROUND																	
DTS-HD MSTR																	
DTS-HD HI RES				●													
DTS ES DSCR16.1	*				⊙												
DTS ES MTRX6.1	*					●											
DTS SURROUND																	
DTS 96/24																	
DTS + PLIIx CINEMA	*																
DTS + PLIIx MUSIC	*																
DTS EXPRESS								●									
DTS + NEO:6	*																
DTS NEO:6 CINEMA																	○
DTS NEO:6 MUSIC																	○
DOLBY SURROUND																	
DOLBY TrueHD																	
DOLBY DIGITAL+																	
DOLBY DIGITAL EX	*																
DOLBY DIGITAL																	
DOLBY (D) +PLIIx CINEMA	*																
DOLBY (D) +PLIIx MUSIC	*																
DOLBY PRO LOGIC IIX CINEMA	*																
DOLBY PRO LOGIC IIX MUSIC	*																
DOLBY PRO LOGIC IIX GAME	*																
DOLBY PRO LOGIC II CINEMA	*																
DOLBY PRO LOGIC II MUSIC	*																
DOLBY PRO LOGIC II GAME	*																
DOLBY PRO LOGIC																	

* If "Speaker Config." = "S.B(Pre)" is set to "None", this surround mode cannot be selected.

Surround mode	NOTE	Input signal types and formats															
		ANALOG		PCM		DTS-HD		DTS			DOLBY		DOLBY DIGITAL				
		LINEAR PCM (multi ch)	LINEAR PCM (2ch)	DTS-HD Master Audio	DTS-HD High Resolution Audio	DTS EXPRESS	DTS ES DSCRT (With Flag)	DTS ES MTRX (With Flag)	DTS (5.1ch)	DTS 96/24	DOLBY TrueHD	DOLBY DIGITAL Plus	DOLBY DIGITAL EX (With Flag)	DOLBY DIGITAL EX (With no Flag)	DOLBY DIGITAL (5.1/5.4ch)	DOLBY DIGITAL (4/3ch)	DOLBY DIGITAL (2ch)
MULTI CH IN																	
MULTI CH IN		●															
MULTI CH IN + PLIIx CINEMA	*	○															
MULTI CH IN + PLIIx MUSIC	*	○															
MULTI CH IN 7.1		●◎ (7.1)															
DIRECT																	
DIRECT		○															
DSP SIMULATION																	
MULTI CH STEREO		○															
VIRTUAL		○															
STEREO																	
STEREO		●															

* If "Speaker Config." - "S.B(Pre)" is set to "None", this surround mode cannot be selected.

TROUBLE SHOOTING

1. POWER

1.1. Power not turn on

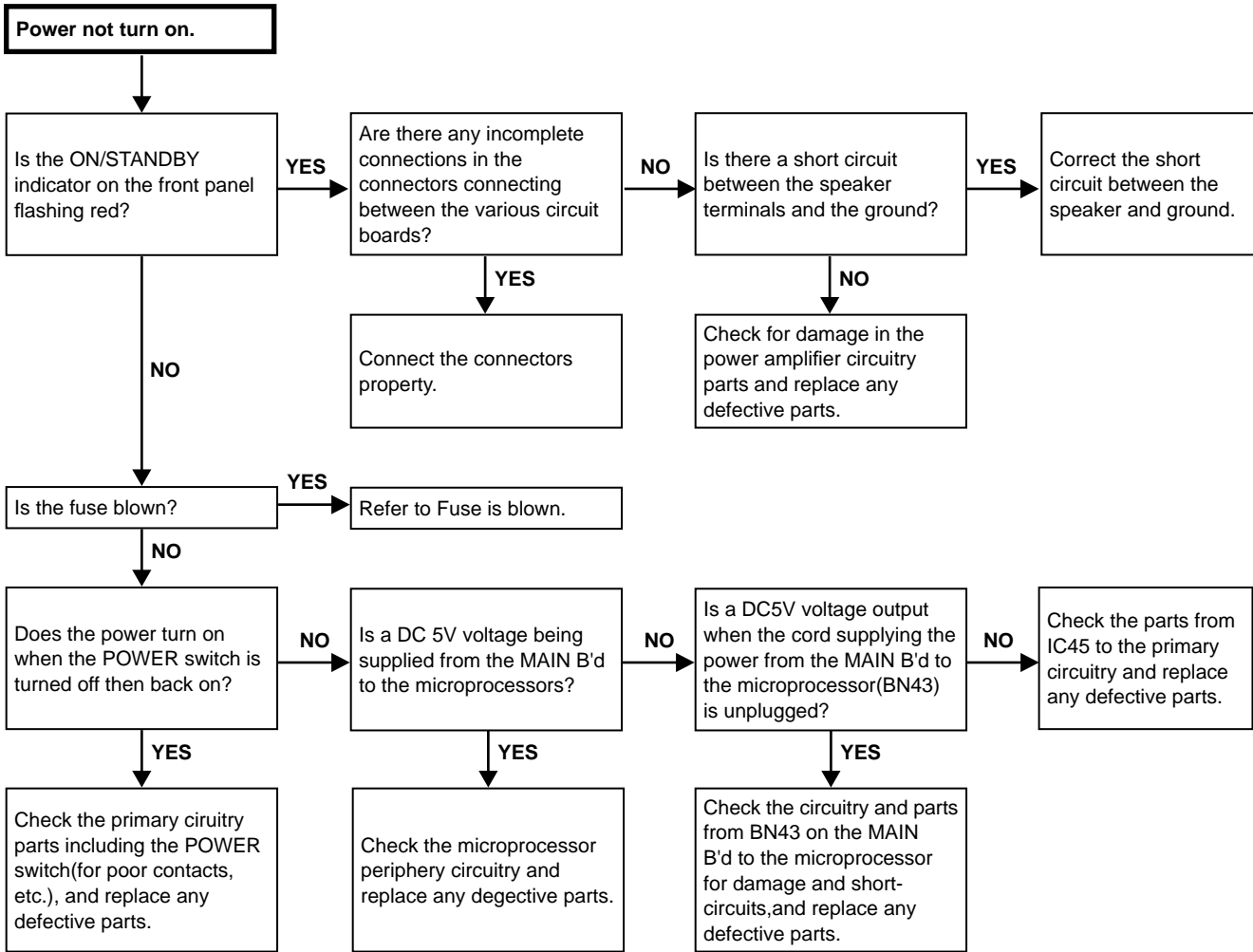

1.2. Fuse is blown

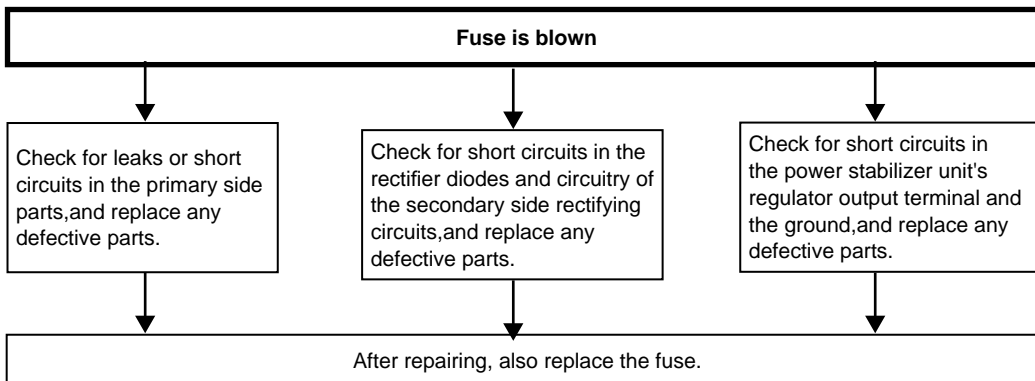

2. Analog video

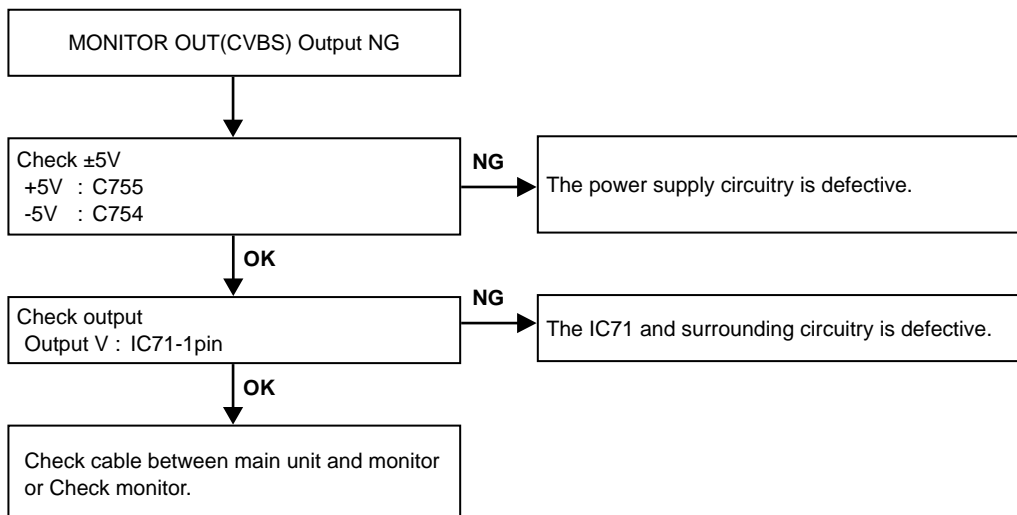

AVR-1311 model only

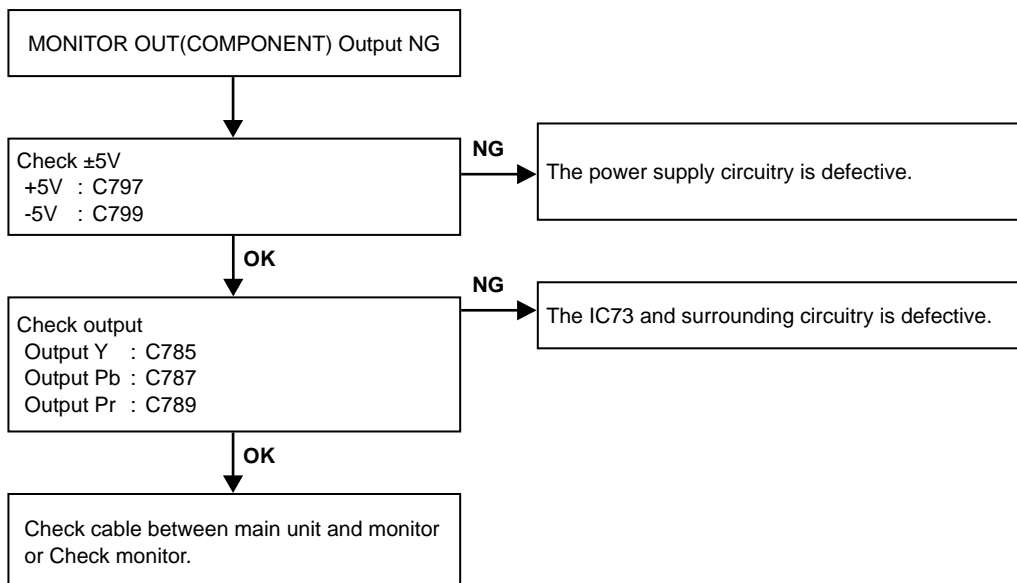

3. HDMI/DVI

3.1. No picture or sound is output

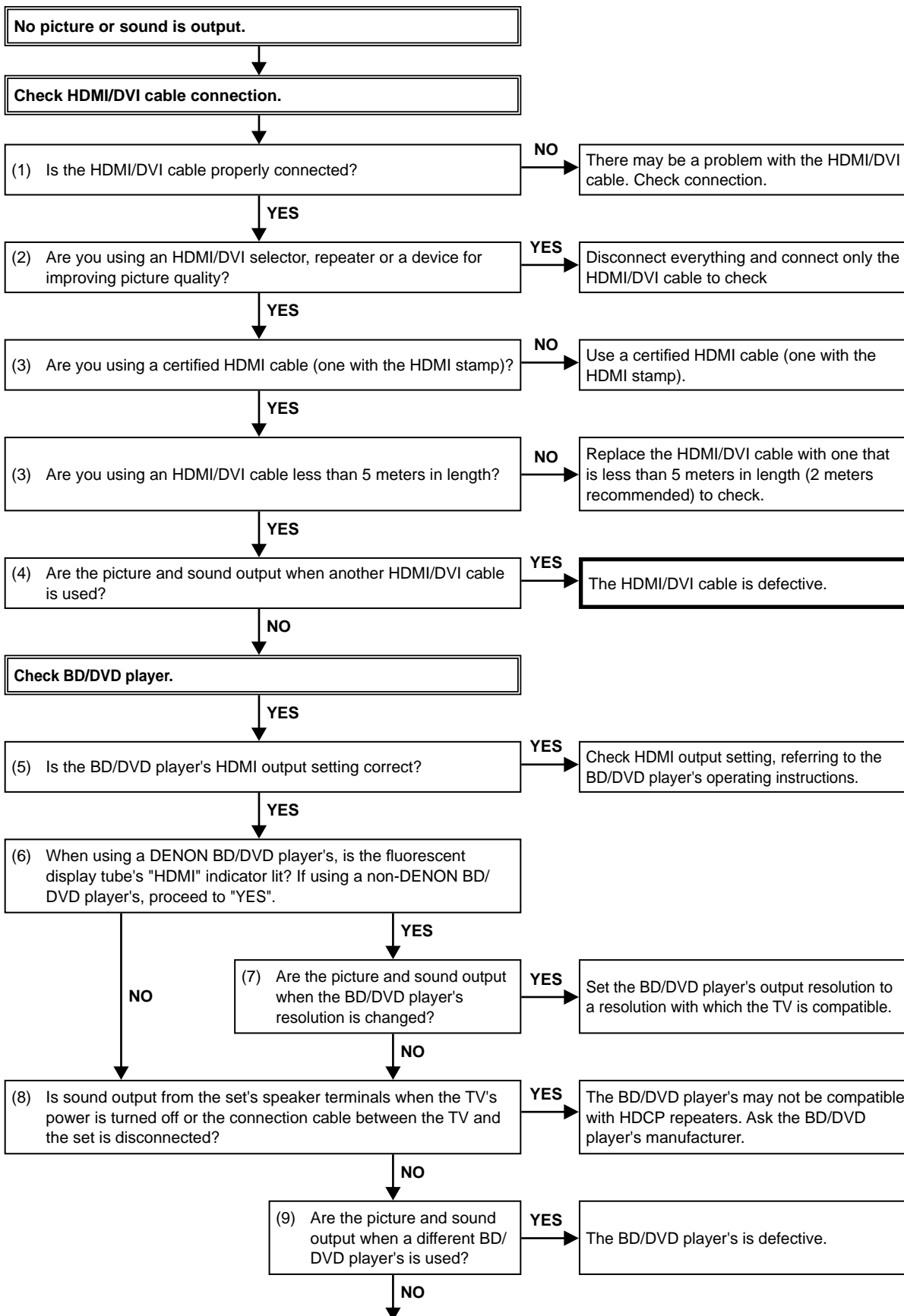

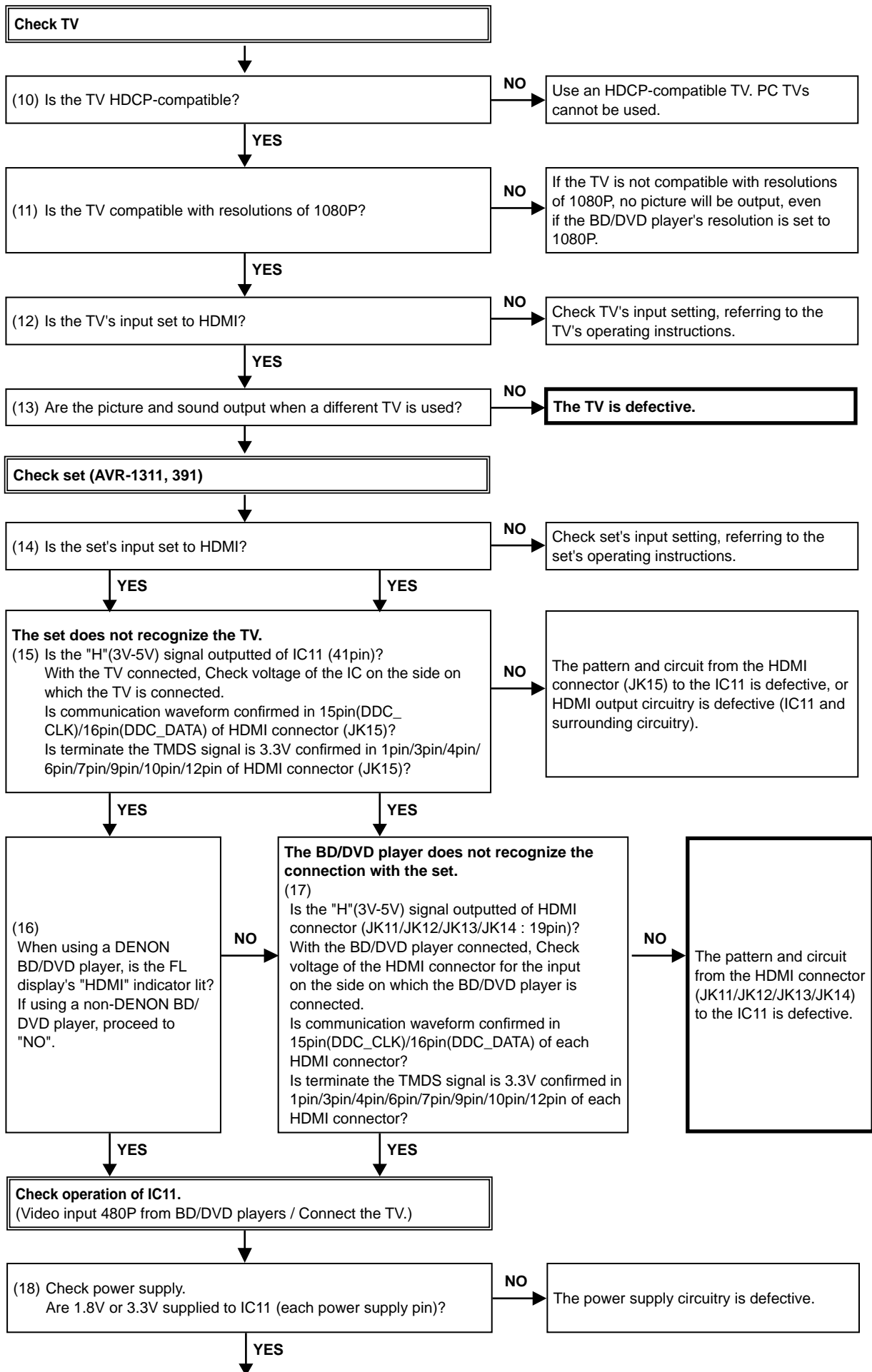

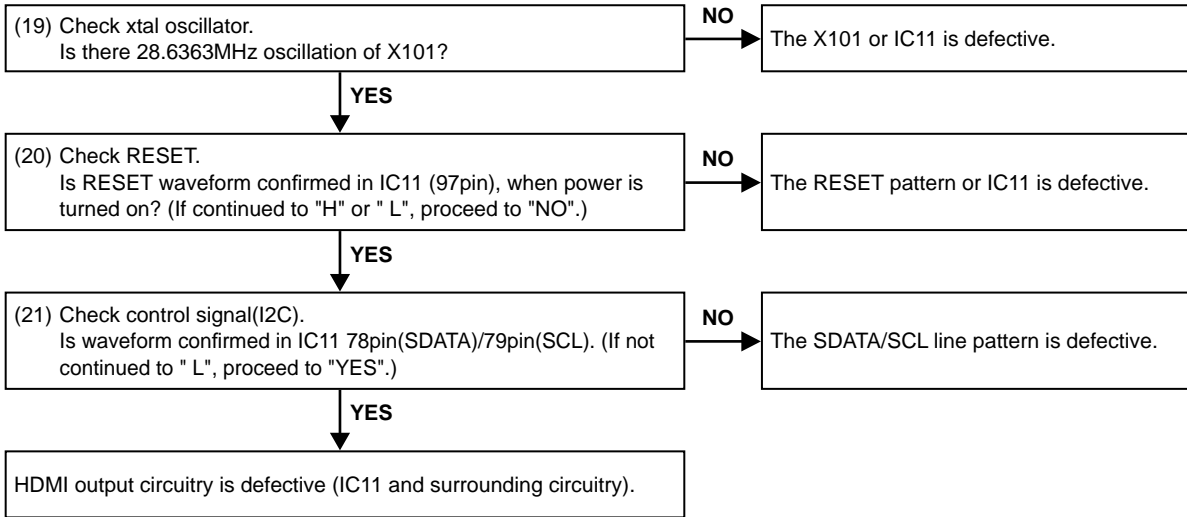

3.2. HDMI test point and waveforms

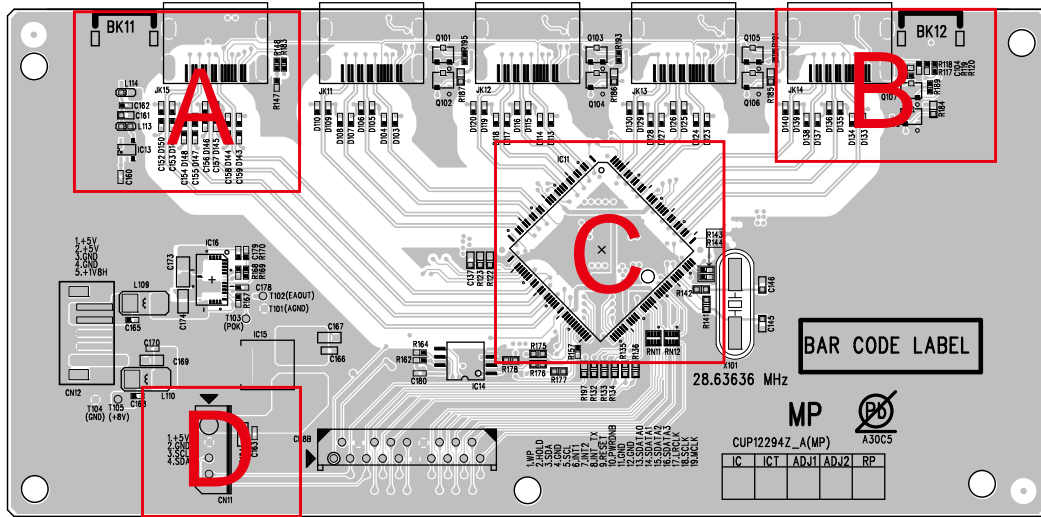

Detail A

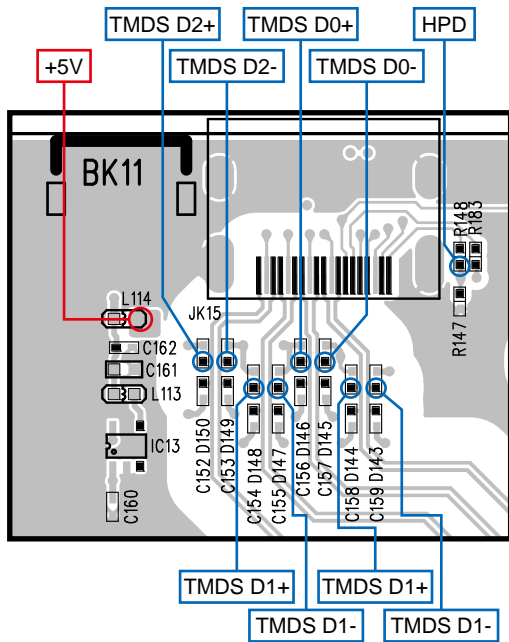

Detail B

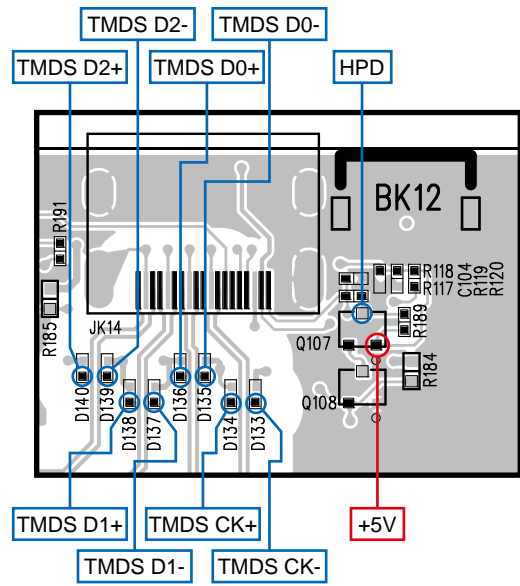

Detail C

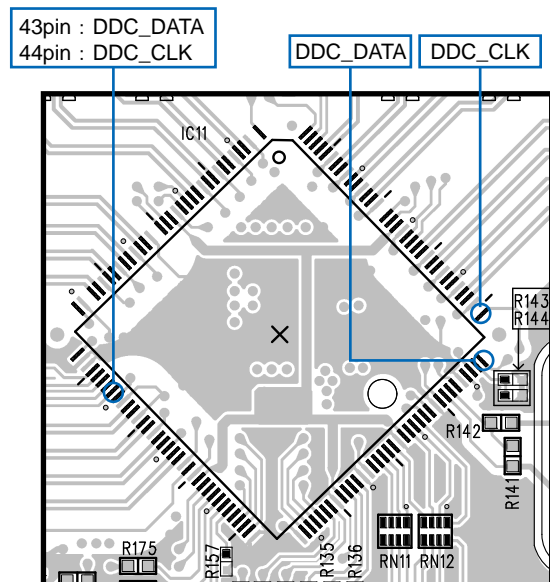

Detail D

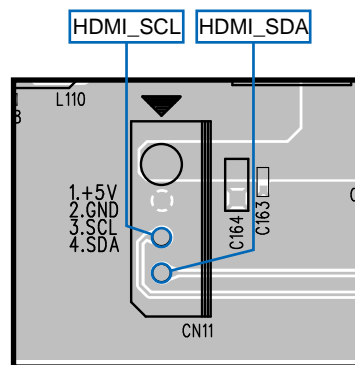

DDC_CLK/DDC_DATA/TMDS : Check item (15),(17)

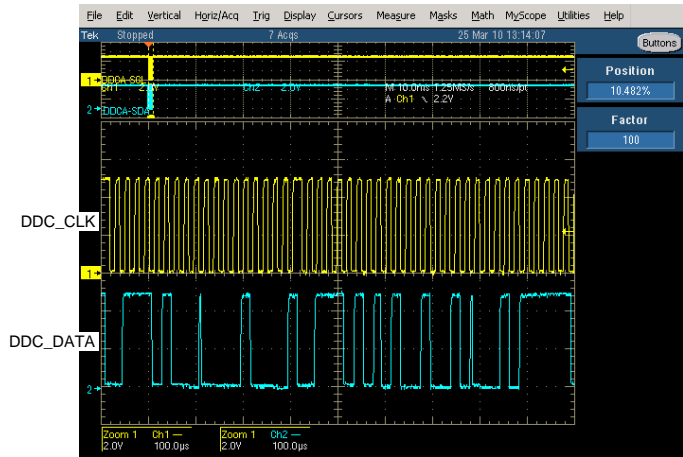
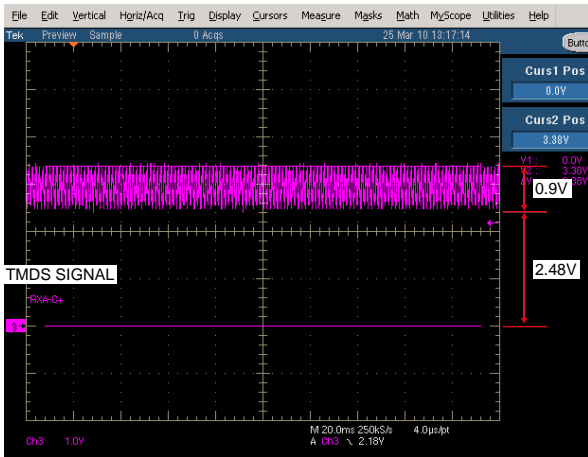

IPINDE/IPINVSNC/IPINHSNC/IPINPCK : Check item (21)

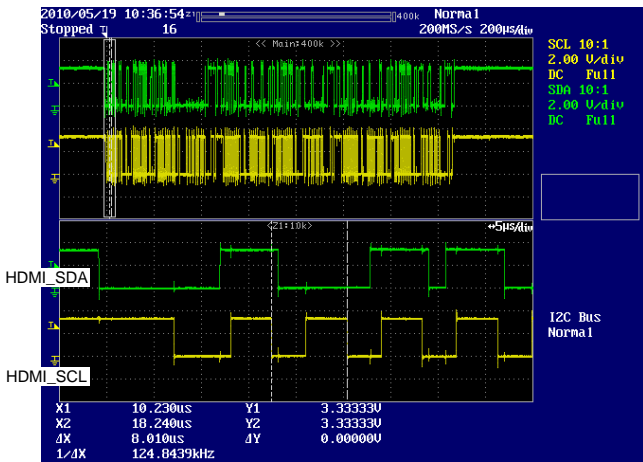

CLOCK FLOW & WAVE FORM IN DIGITAL BLOCK

Wave form

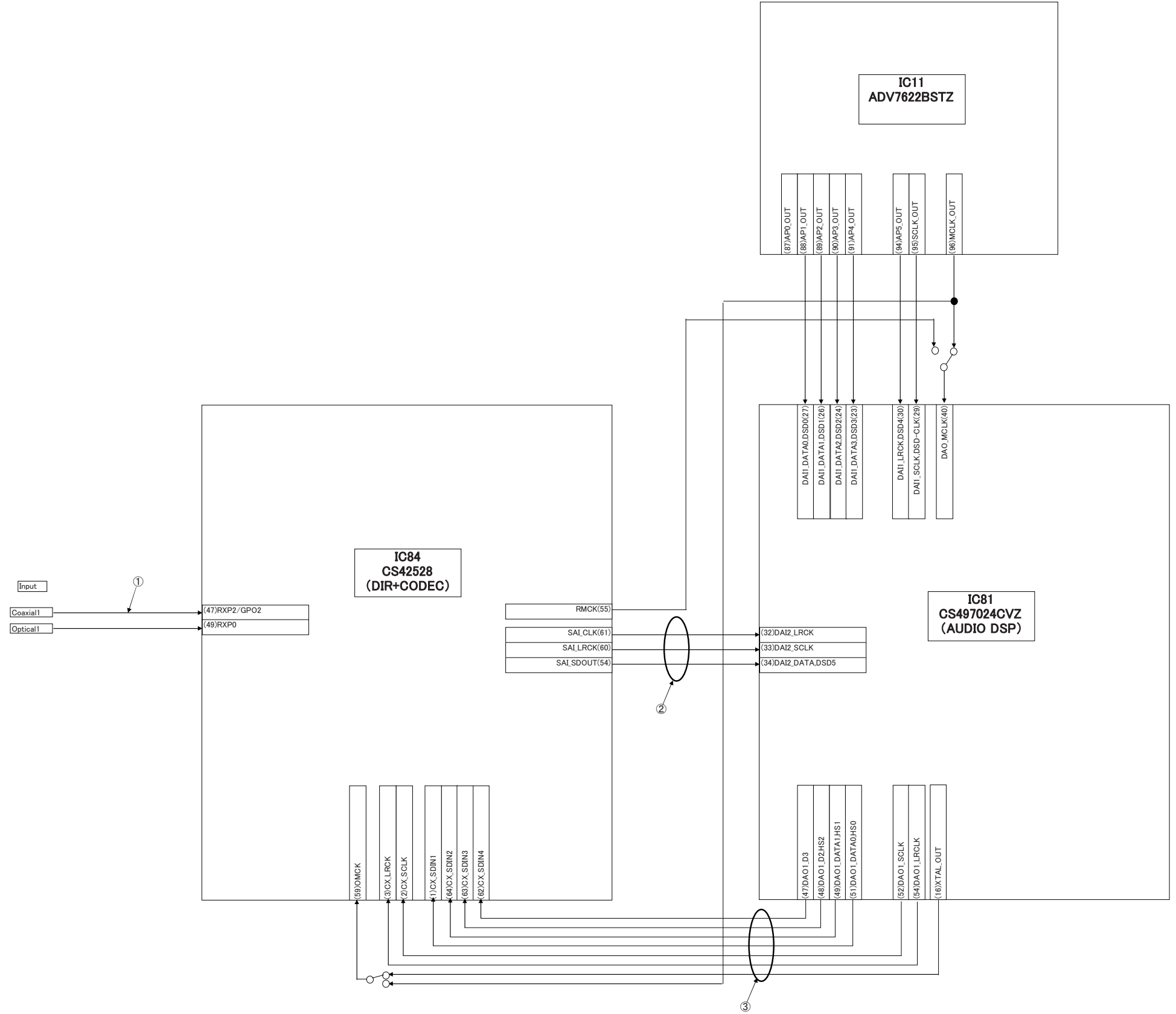
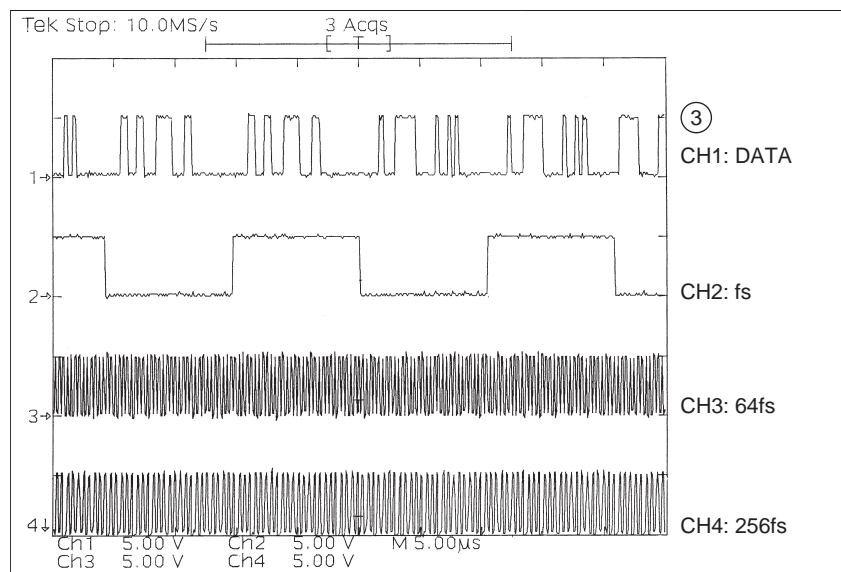
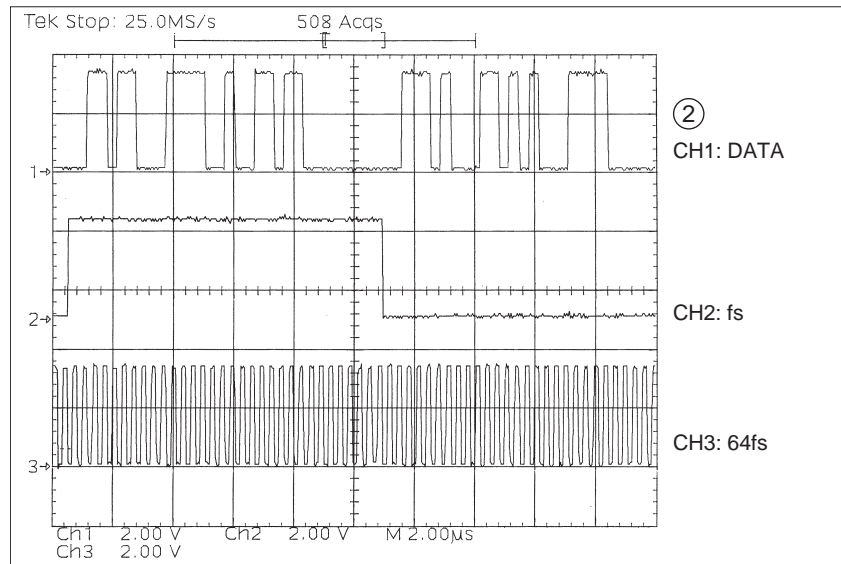
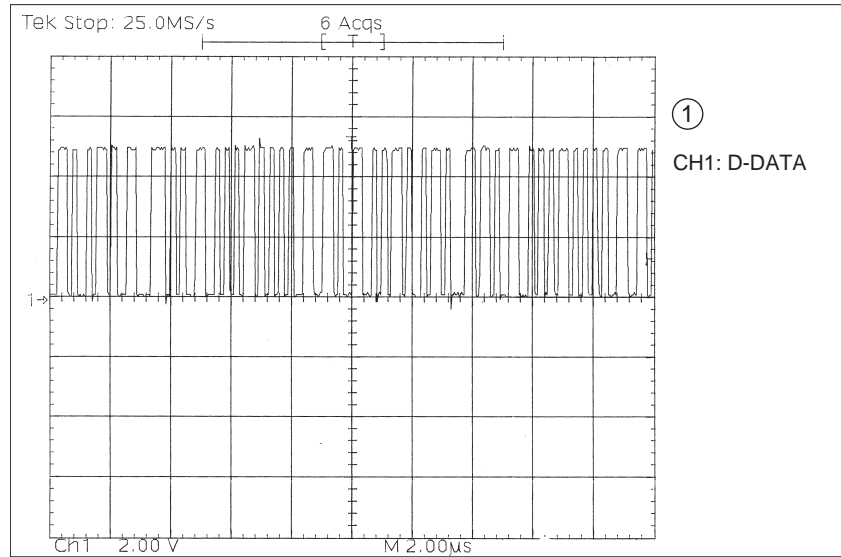

BLOCK DIAGRAM

ANALOG AUDIO BLOCK

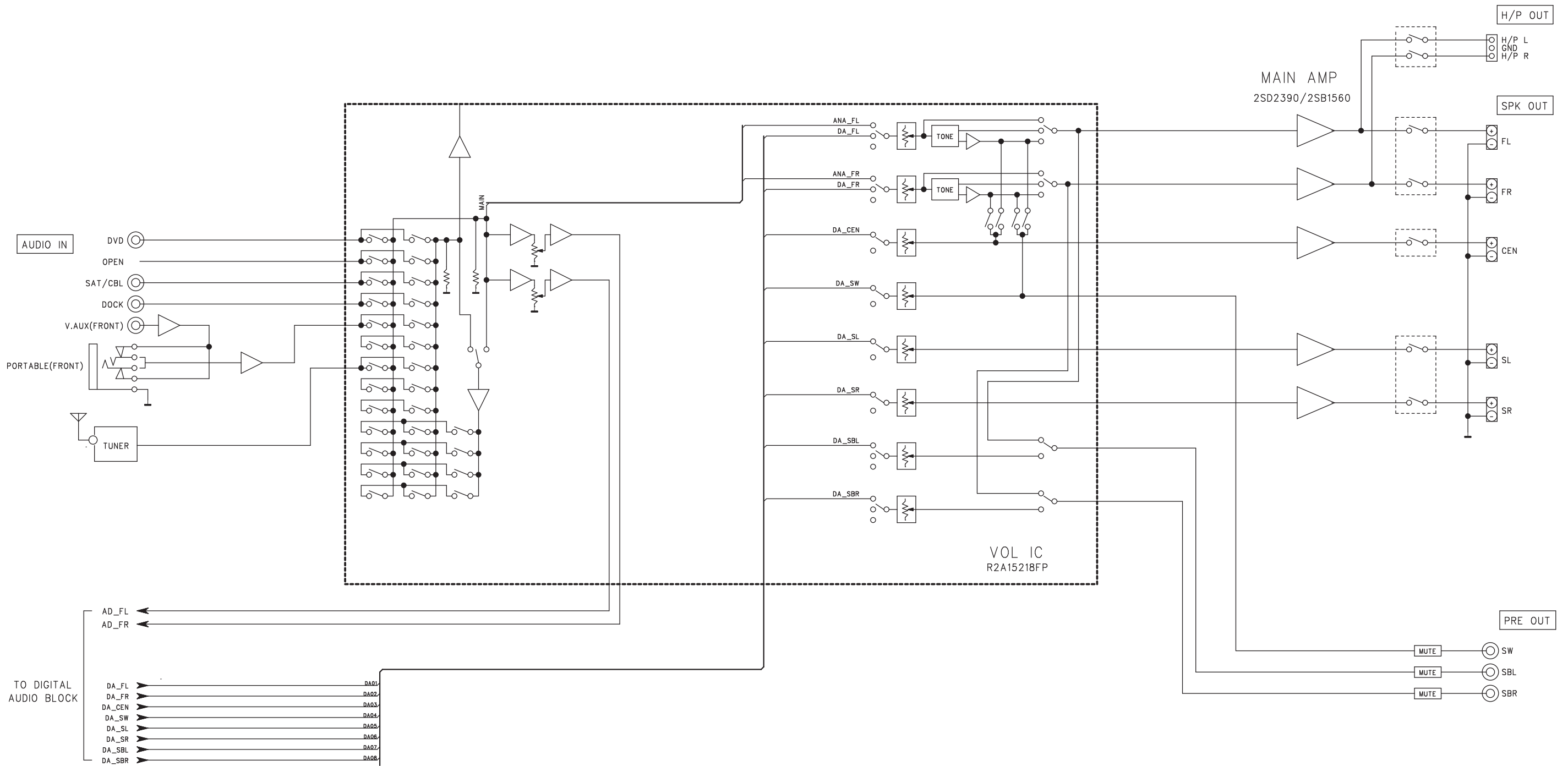

DIGITAL AUDIO BLOCK

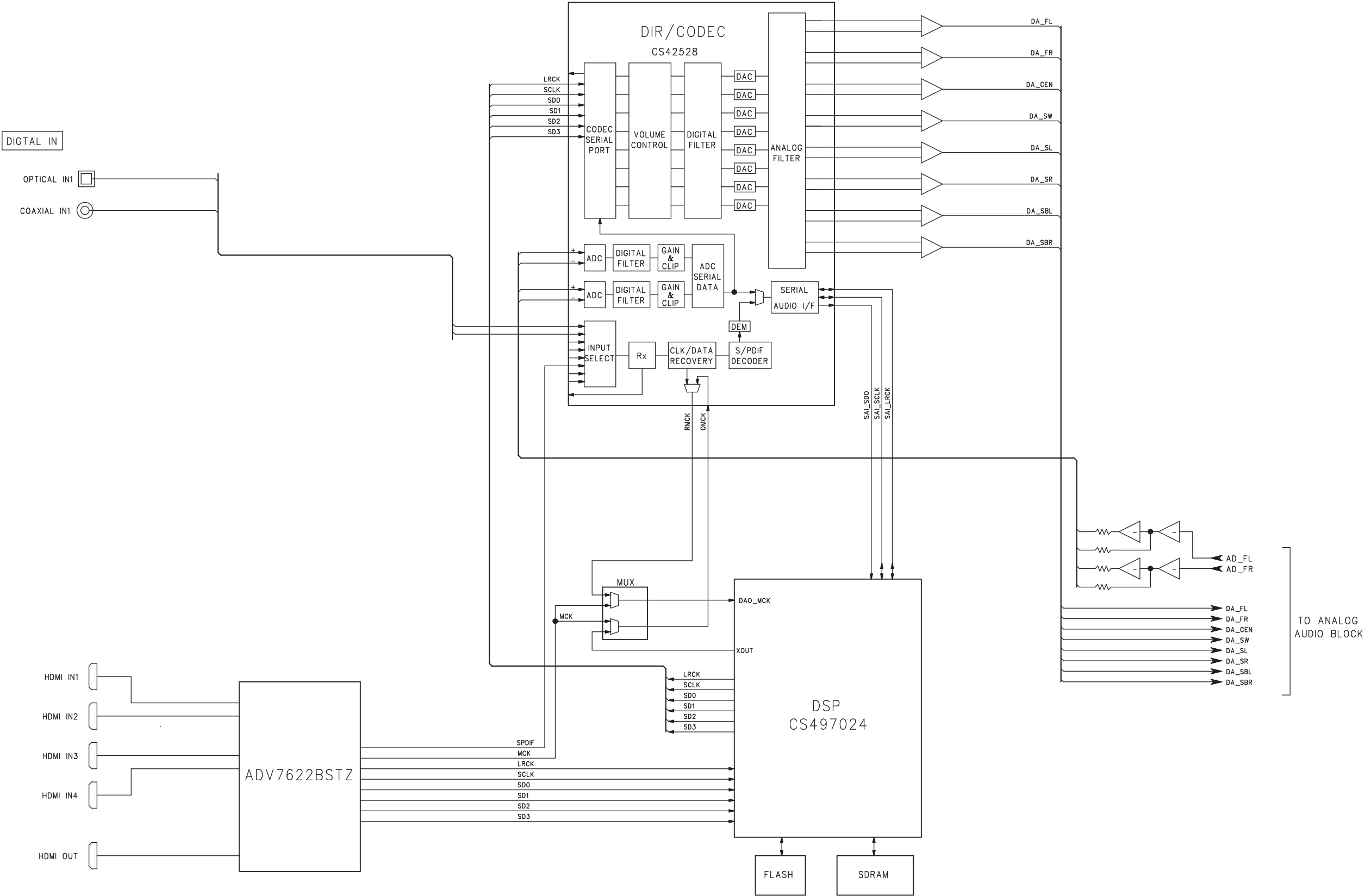

VIDEO BLOCK

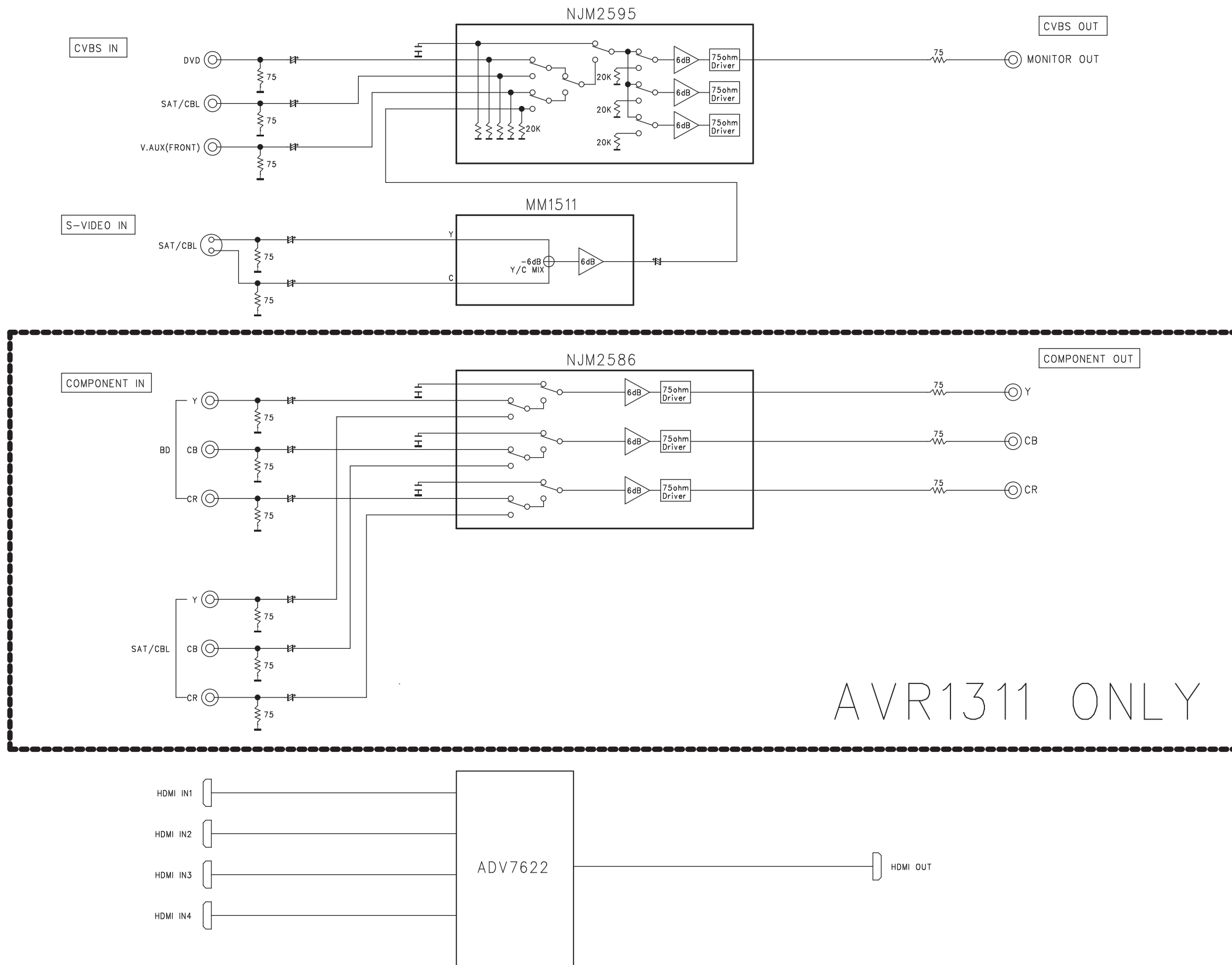

POWER BLOCK DIAGRAM

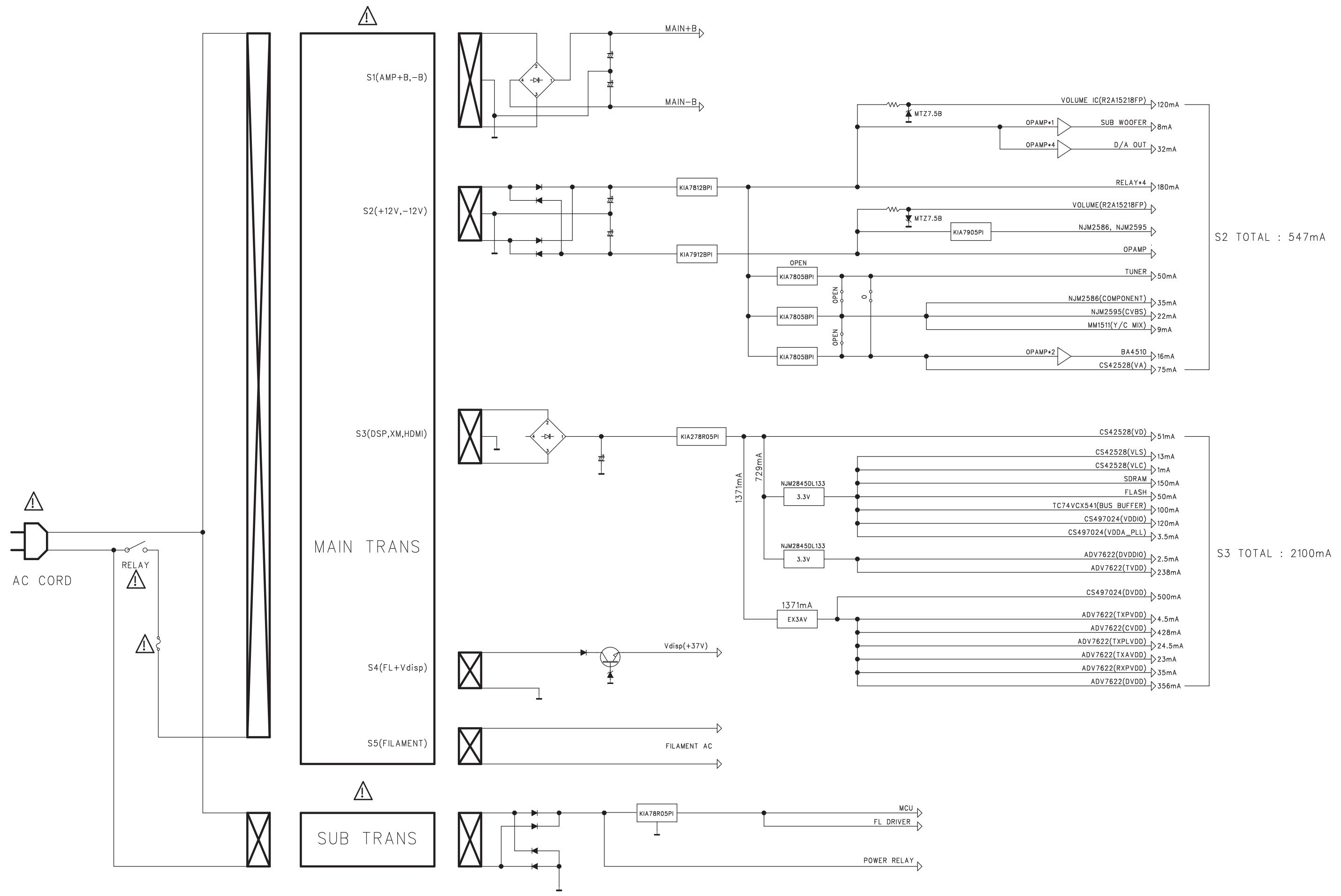

5CH LEVEL DIAGRAM

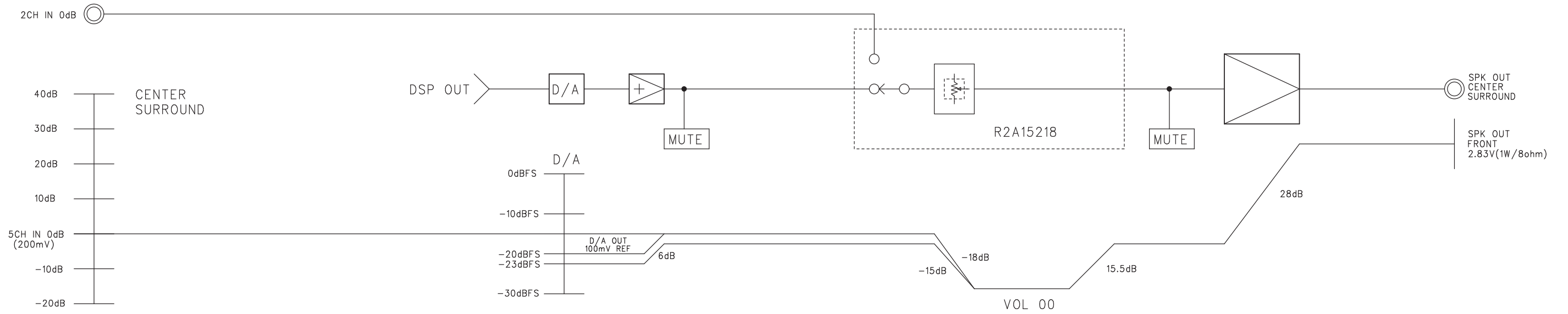
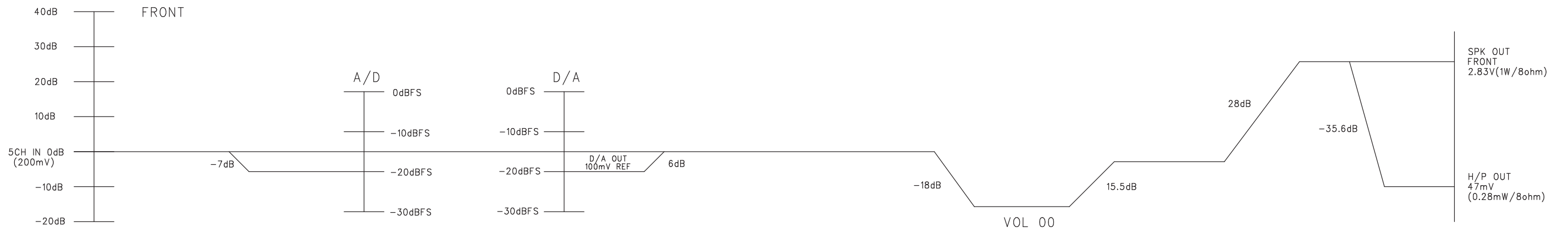
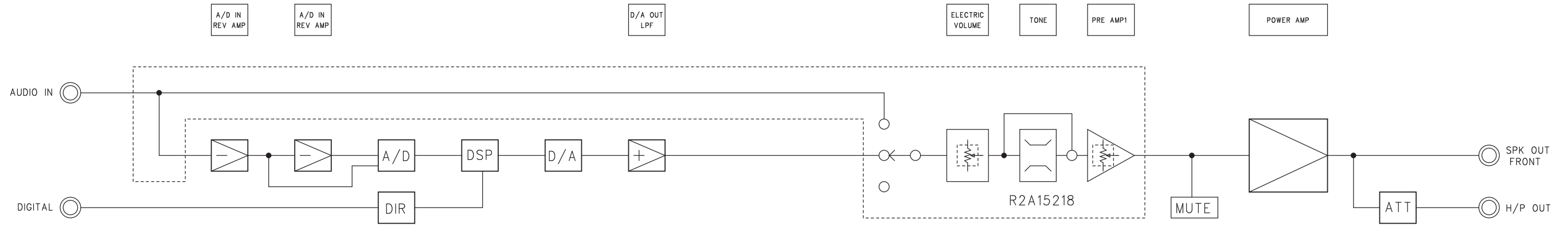

SUB WOOFER LEVEL DIAGRAM

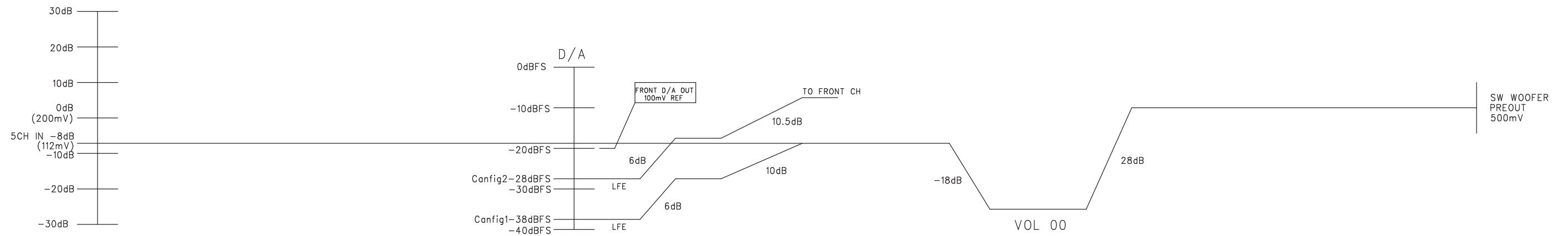
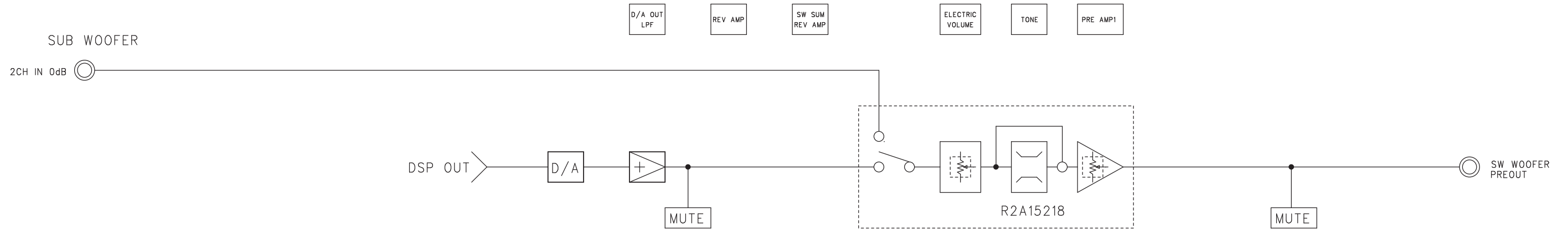

PRINTED WIRING BOARDS

FRONT (COMPONENT SIDE)

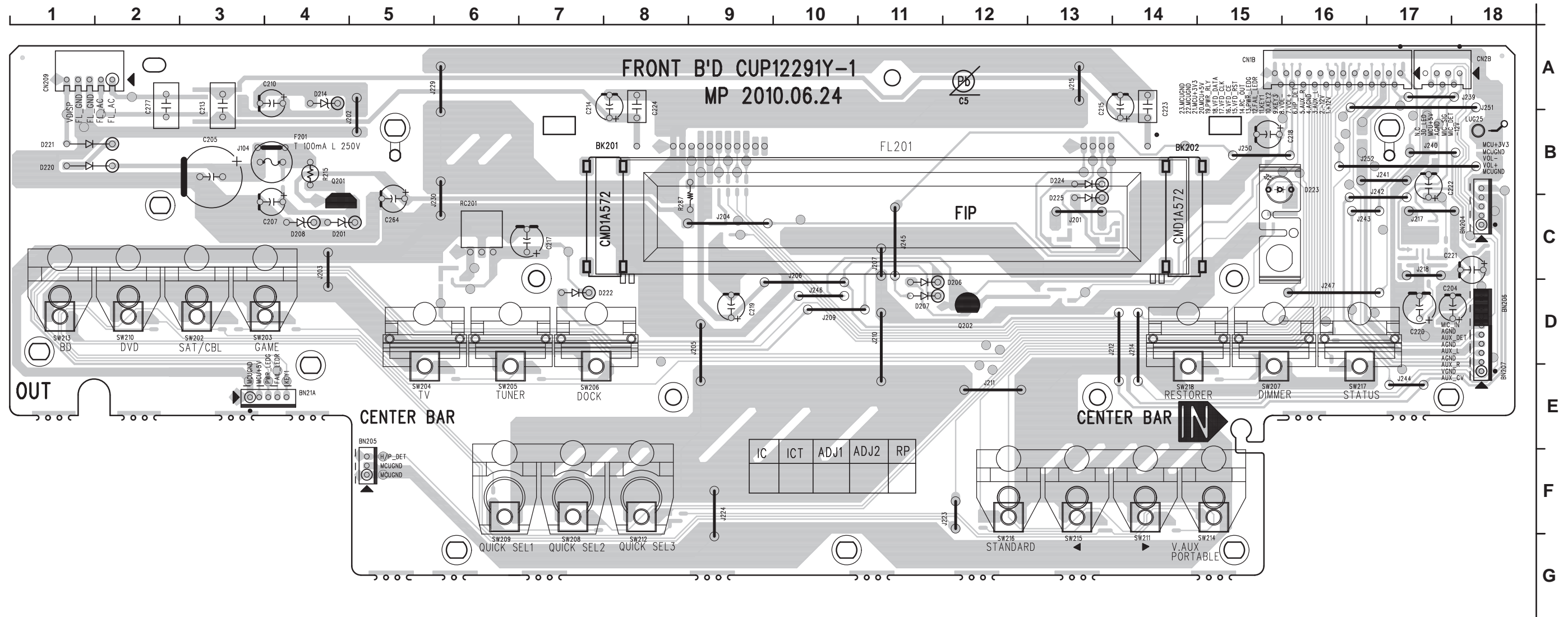

PHONE (COMPONENT SIDE)

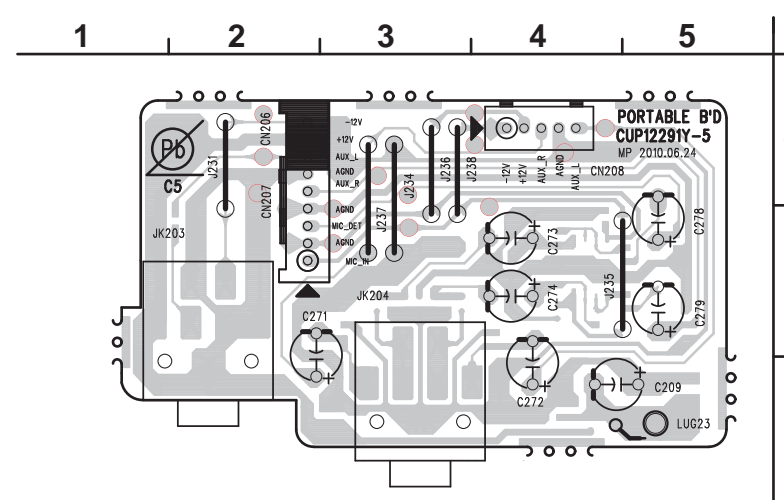

HEADPHONE (COMPONENT SIDE)

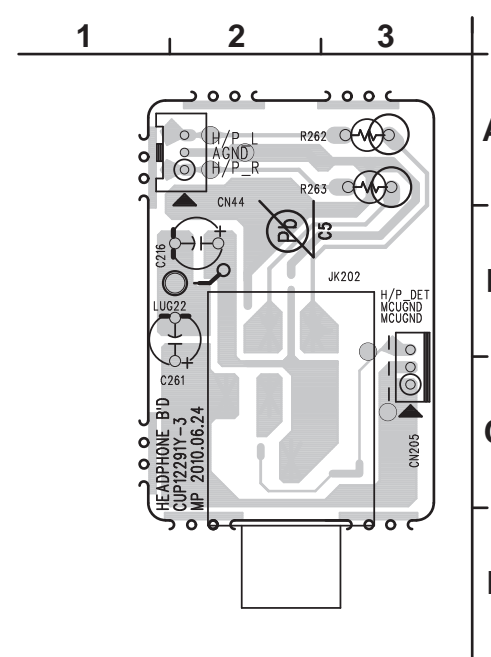

REGULATOR (COMPONENT SIDE)

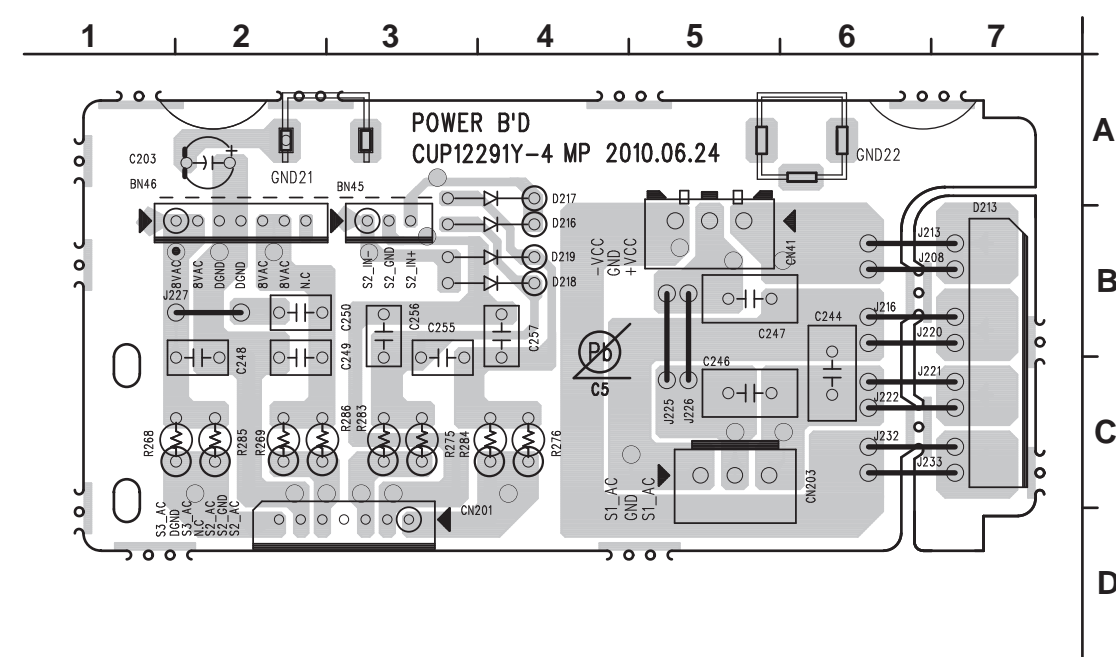

鉛フリー半田
半田付けには、鉛フリー半田 (Sn-Ag-Cu) を使用してください。

Lead-free Solder
When soldering, use the Lead-free Solder (Sn-Ag-Cu).

FRONT (FOIL SIDE)

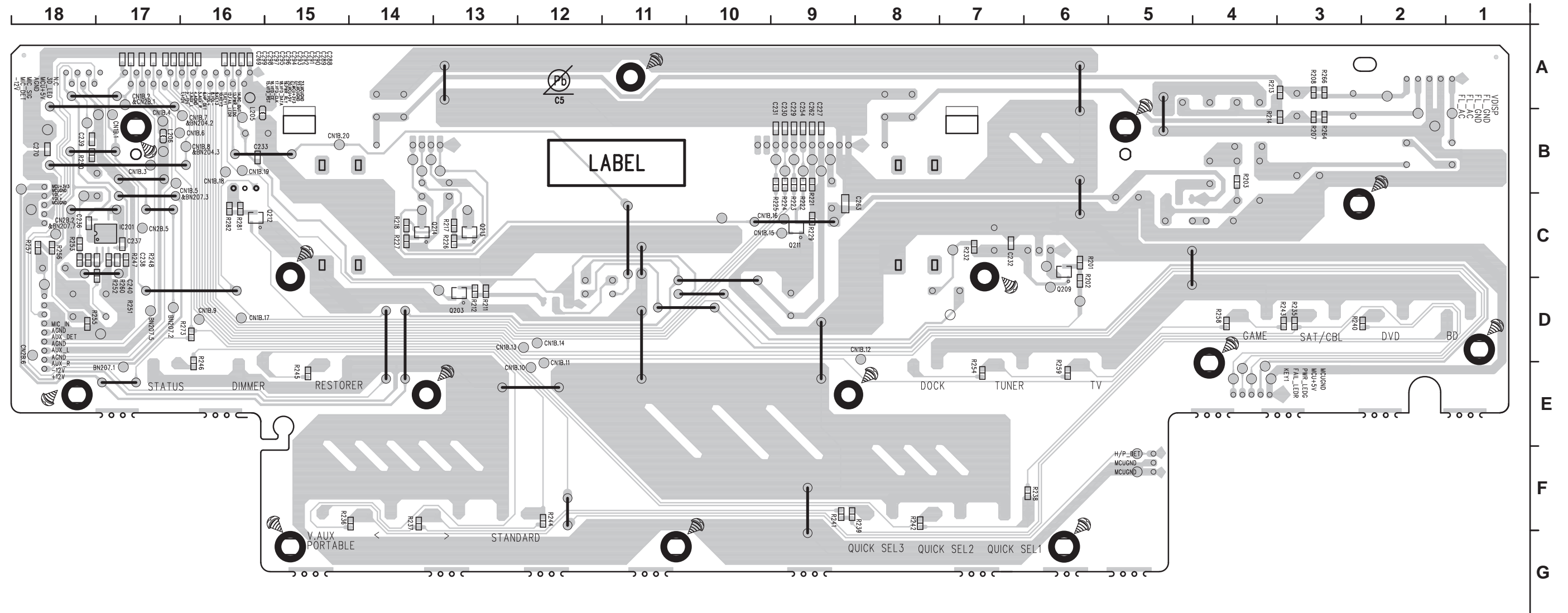

PHONE (FOIL SIDE)

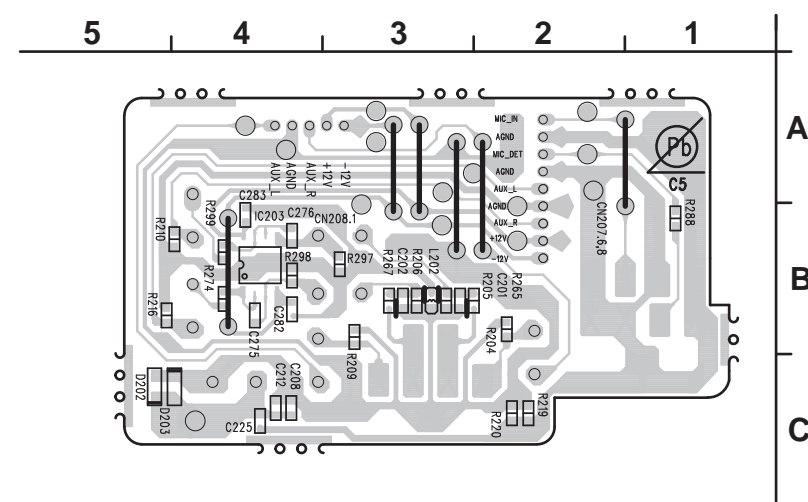

HEADPHONE (FOIL SIDE)

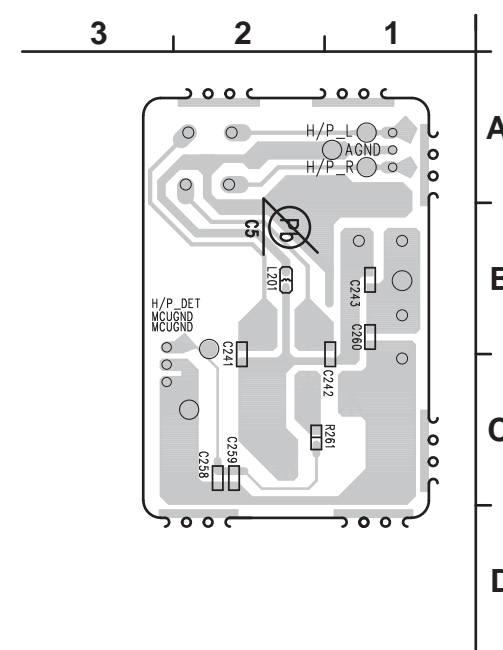

REGULATOR (FOIL SIDE)

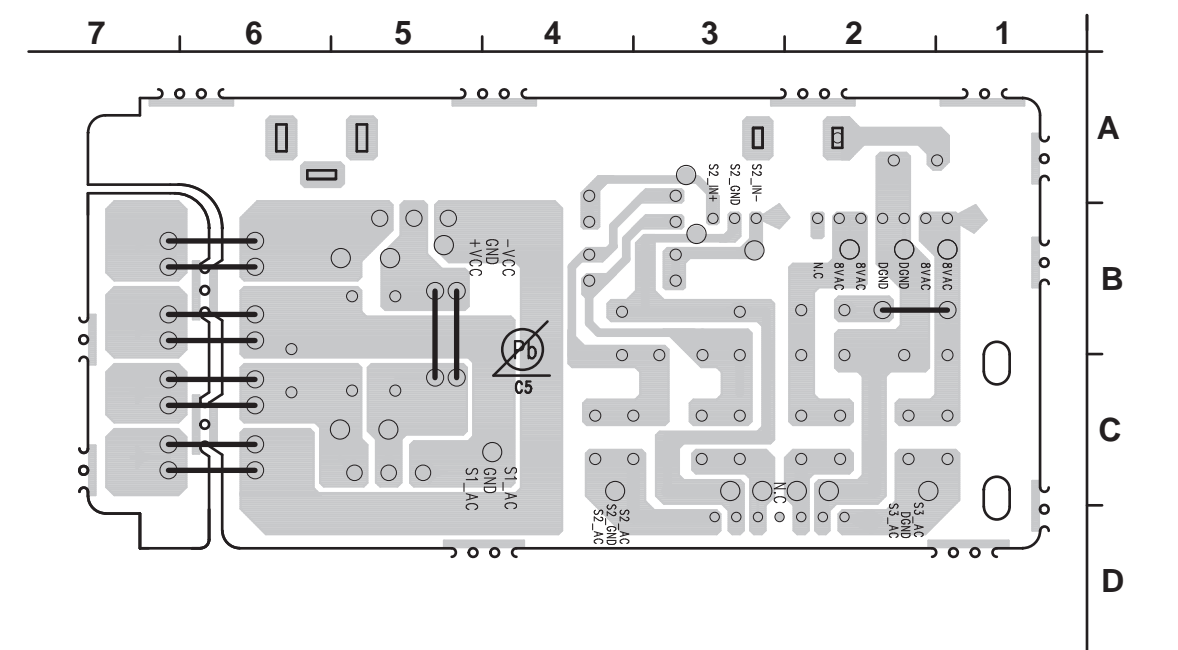

鉛フリー半田

半田付けには、鉛フリー半田 (Sn-Ag-Cu) を使用してください。

Lead-free Solder

When soldering, use the Lead-free Solder (Sn-Ag-Cu).

VOLUME (COMPONENT SIDE) ⚠

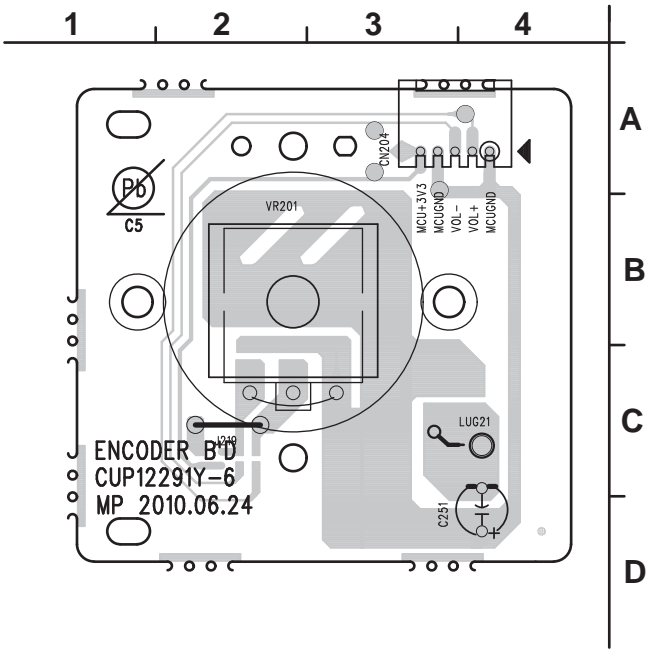

AUX (COMPONENT SIDE) ⚠

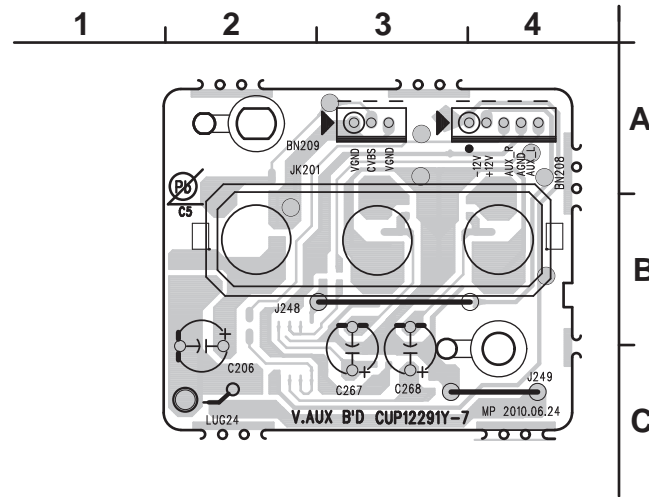

POWER (COMPONENT SIDE) ⚠

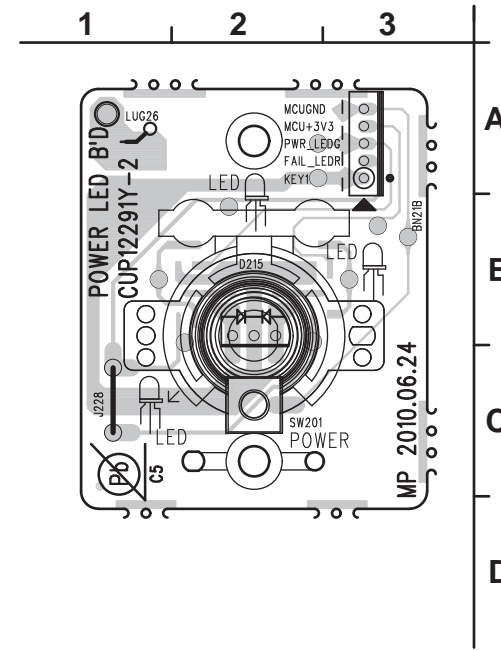

VOLUME (FOIL SIDE) ⚠

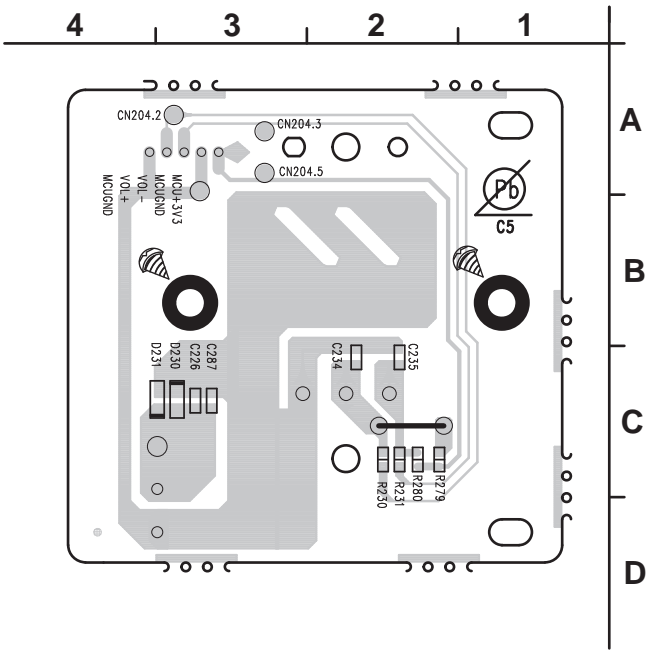

AUX (FOIL SIDE) ⚠

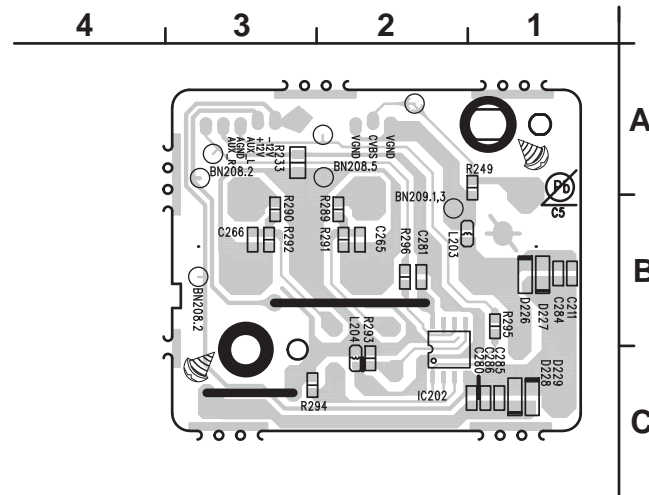

POWER (FOIL SIDE) ⚠

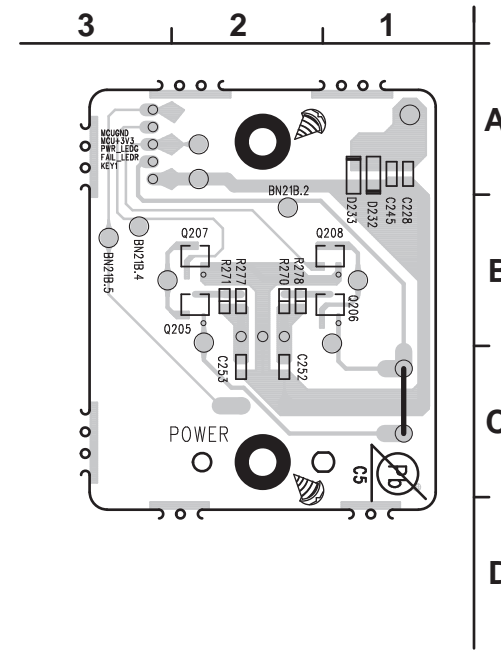

鉛フリー半田
半田付けには、鉛フリー半田 (Sn-Ag-Cu) を使用してください。

Lead-free Solder
When soldering, use the Lead-free Solder (Sn-Ag-Cu).

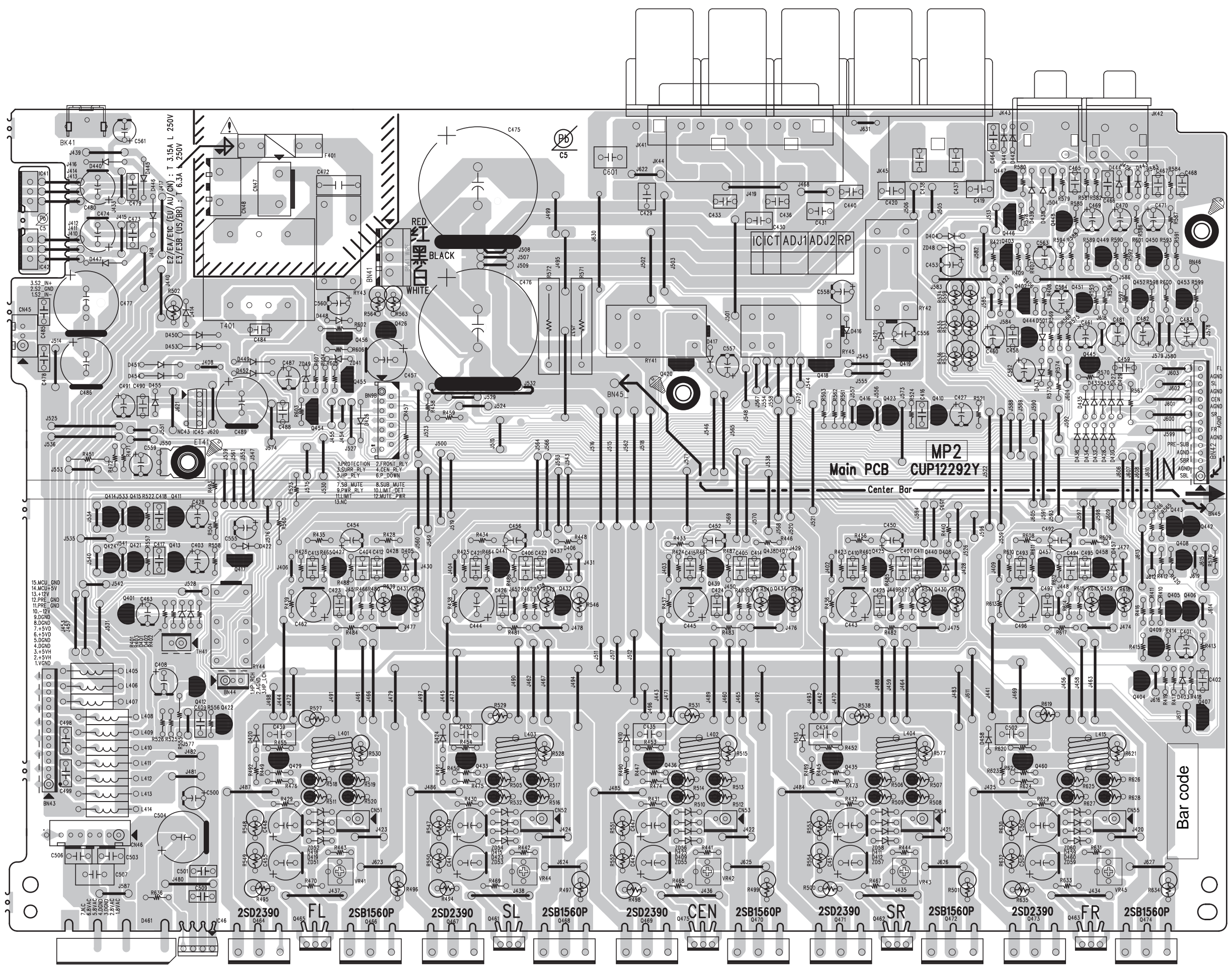

鉛フリー半田
半田付けには、鉛フリー半田 (Sn-Ag-Cu) を使用してください。

Lead-free Solder
When soldering, use the Lead-free Solder (Sn-Ag-Cu).

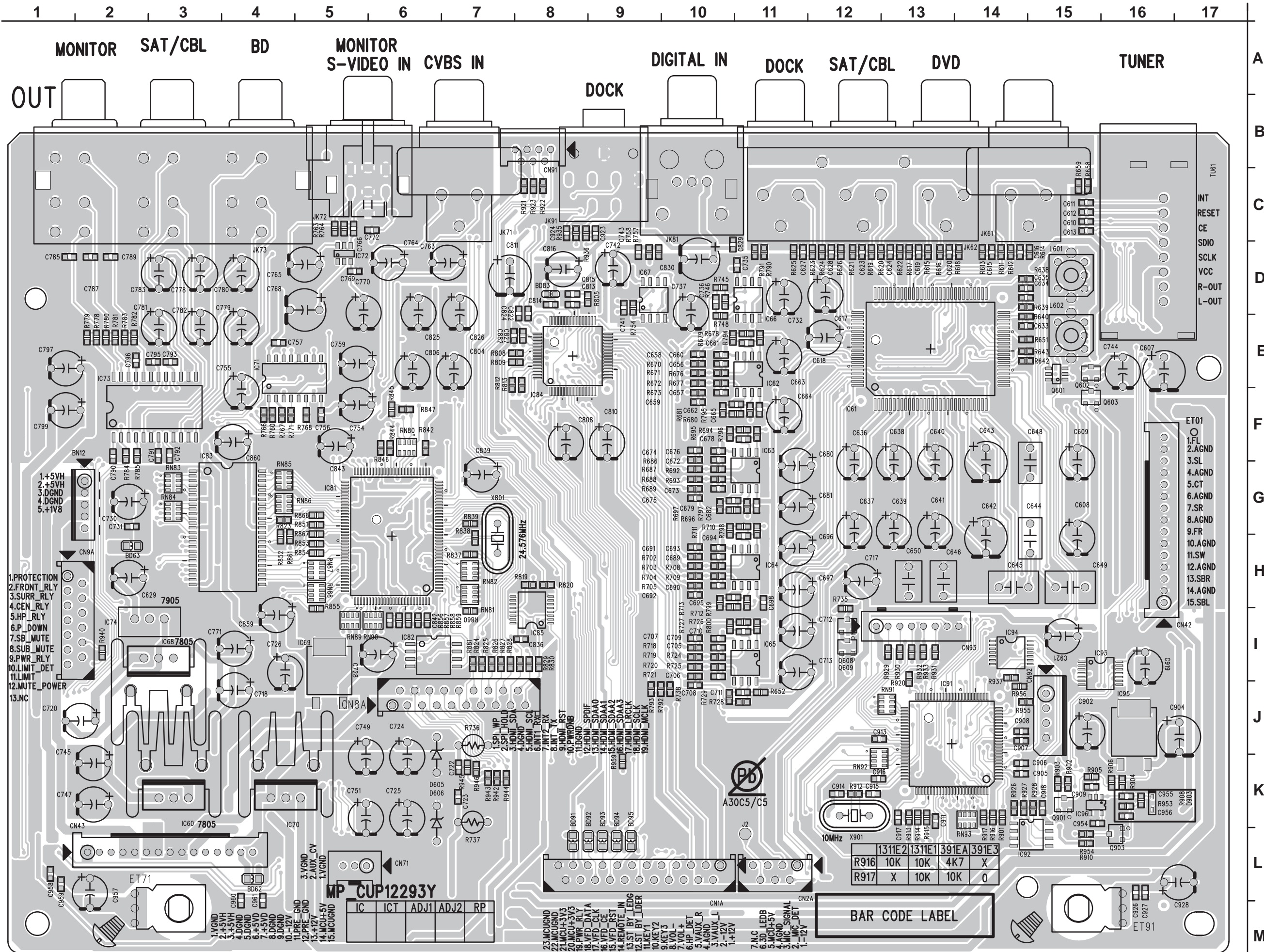

鉛フリー半田
半田付けには、鉛フリー半田 (Sn-Ag-Cu) を使用してください。

Lead-free Solder
When soldering, use the Lead-free Solder (Sn-Ag-Cu).

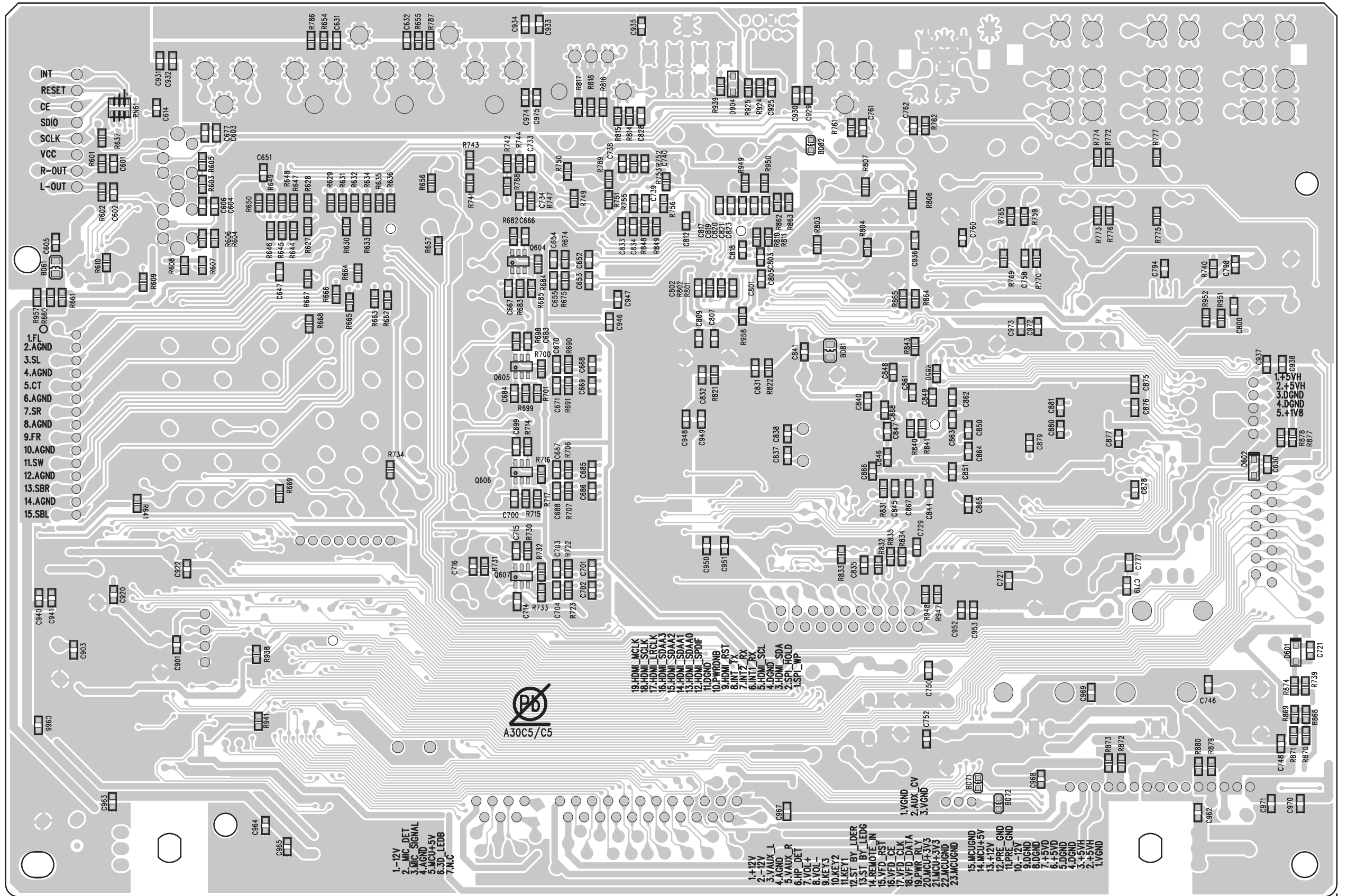

鉛フリー半田
半田付けには、鉛フリー半田 (Sn-Ag-Cu) を使用してください。

Lead-free Solder
When soldering, use the Lead-free Solder (Sn-Ag-Cu).

1. -12V
2. MIC_DET
3. MIC_SIGNAL
4. AGND
5. MCU+5V
6. 3.0 LEDB
7. N.C

19. HDMI_MCLK
18. HDMI_SCLK
17. HDMI_LRCLK
16. HDMI_SDA_A2
15. HDMI_SDA_A3
14. HDMI_SDA_A1
13. HDMI_SDA_A0
12. HDMI_SSPDIF
11. DGNB
10. PWRONB
9. HDMI_RST
8. INT7_RX
7. INT7_TX
6. HDMI_SCL
5. DGNB_SDA
4. DGNB_SDA
3. SPI_HOLD
2. SPI_WP
1. SP_WP

1. +12V
2. -12V
3. AUX_L
4. AGND
5. AUX_R
6. HP_DET
7. VOL+
8. VOL-
9. KEY3
10. KEY2
11. KEY1
12. ST_BY_LEDG
13. REMOTE_IN
14. REMOTE_IN
15. VFD_RST
16. VFD_CE
17. VFD_CLK
18. VFD_DATA
19. PWR_RLY
20. MCU+3V3
21. MCU+3V3
22. MCU_GND
23. MCU_GND
15. MCU_GND
14. MCU+5V
13. +12V
12. PRE_GND
11. PRE_GND
10. -12V
9. DGNB
8. DGNB
7. +5VD
6. +5VD
5. DGNB
4. DGNB
3. +5VH
2. +5VH
1. V_GND



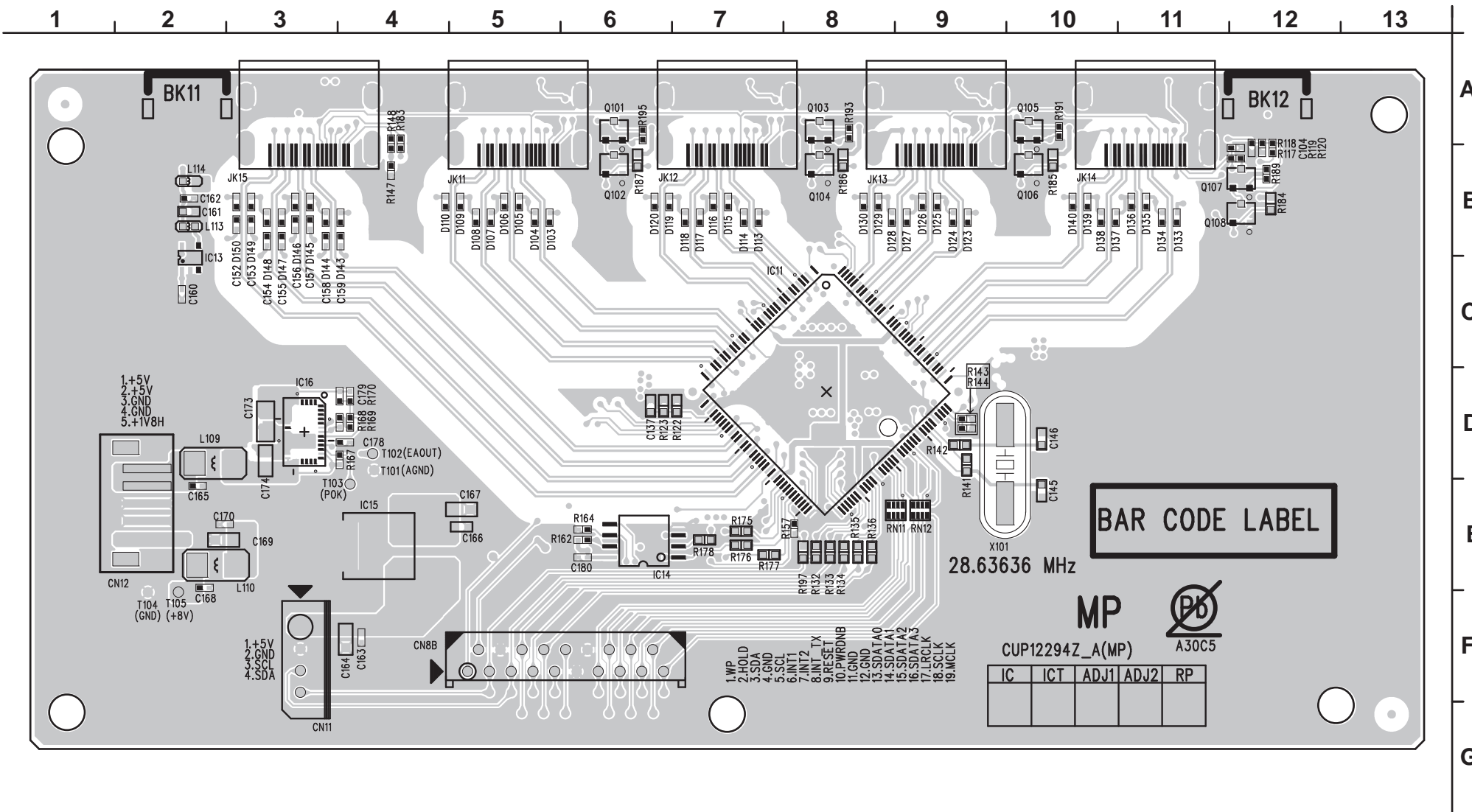

鉛フリー半田
半田付けには、鉛フリー半田 (Sn-Ag-Cu) を使用してください。

Lead-free Solder
When soldering, use the Lead-free Solder (Sn-Ag-Cu).

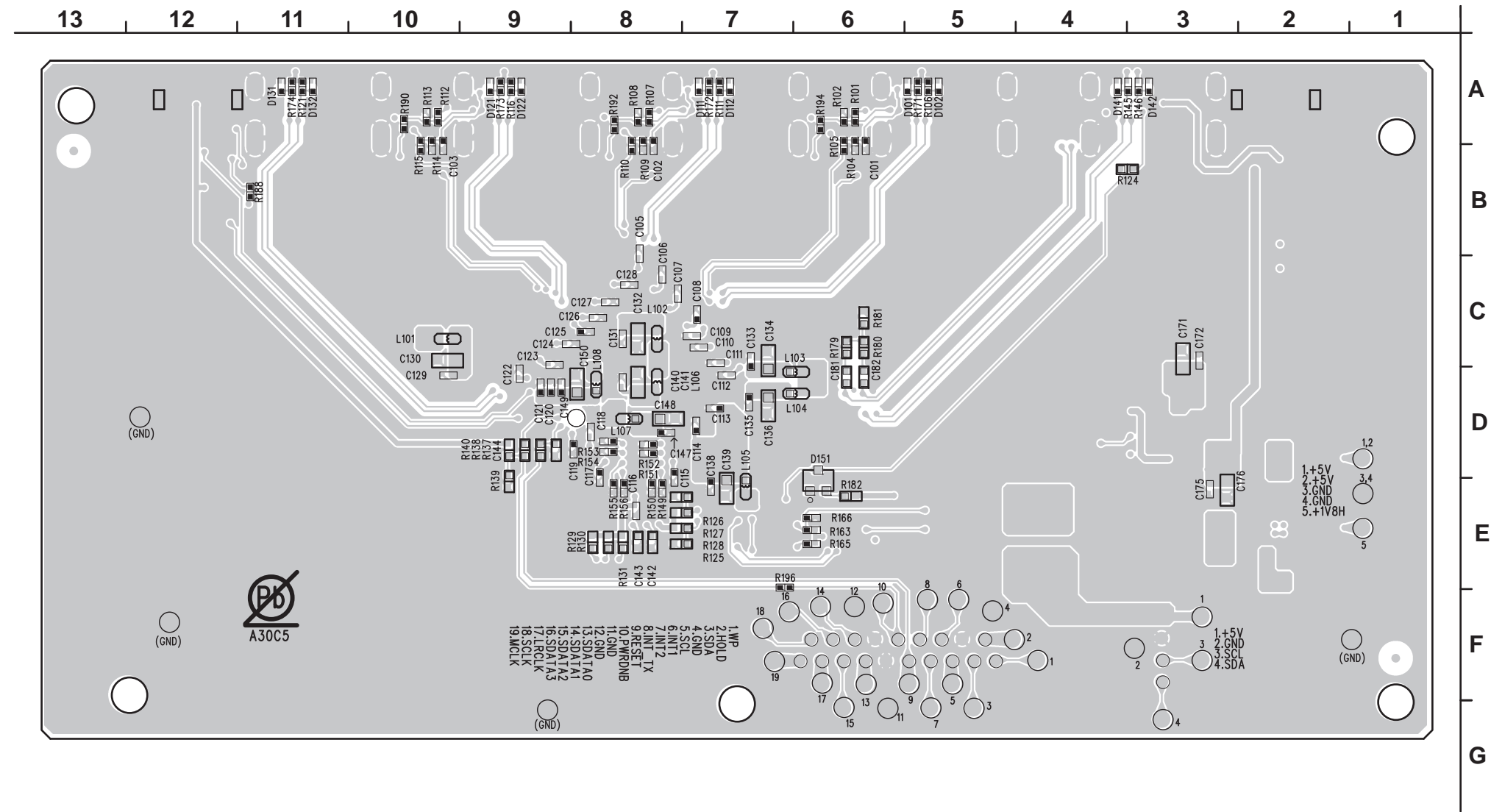

鉛フリー半田
半田付けには、鉛フリー半田 (Sn-Ag-Cu) を使用してください。

Lead-free Solder
When soldering, use the Lead-free Solder (Sn-Ag-Cu).

FRONT PART

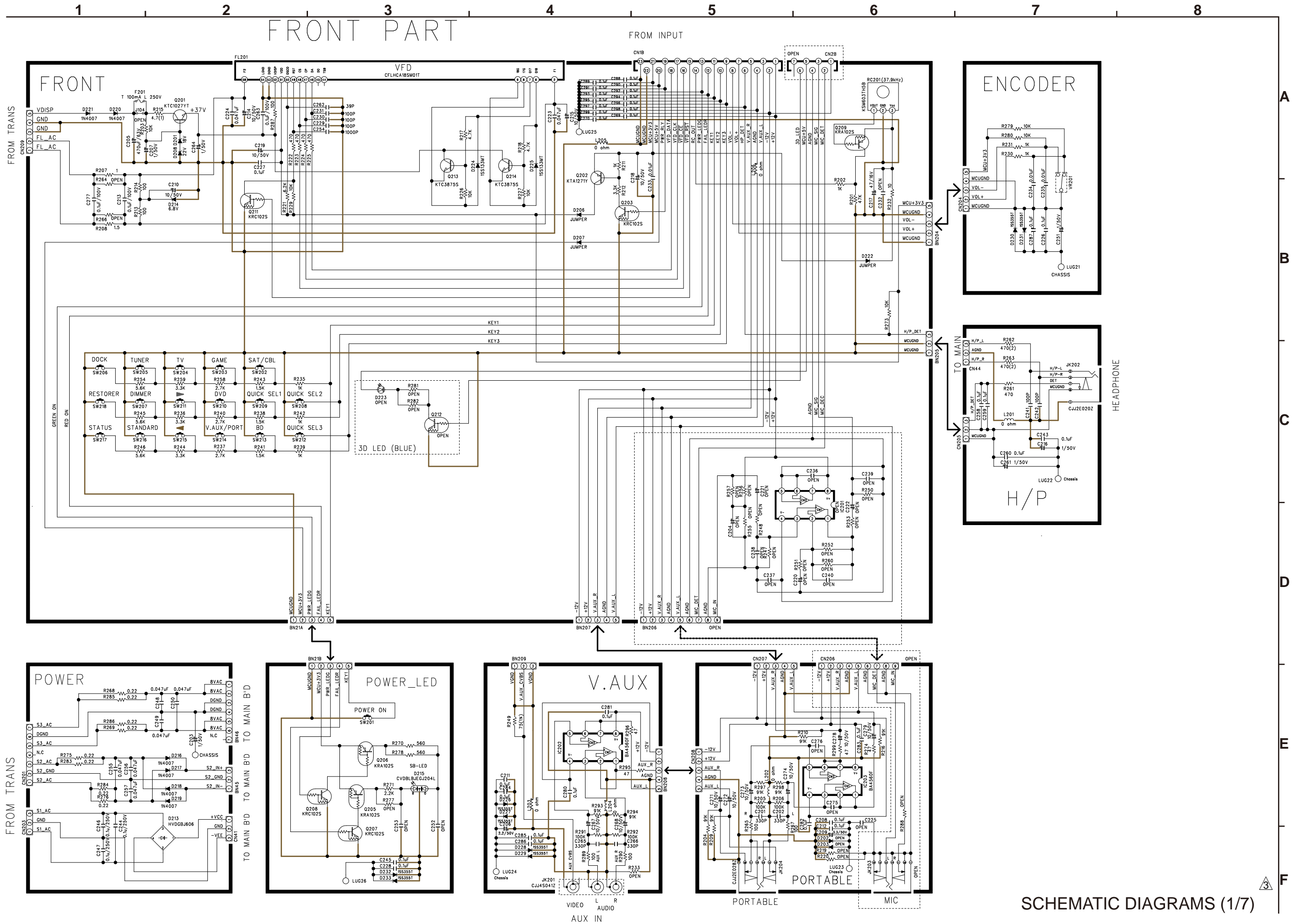

SCHEMATIC DIAGRAMS (1/7)

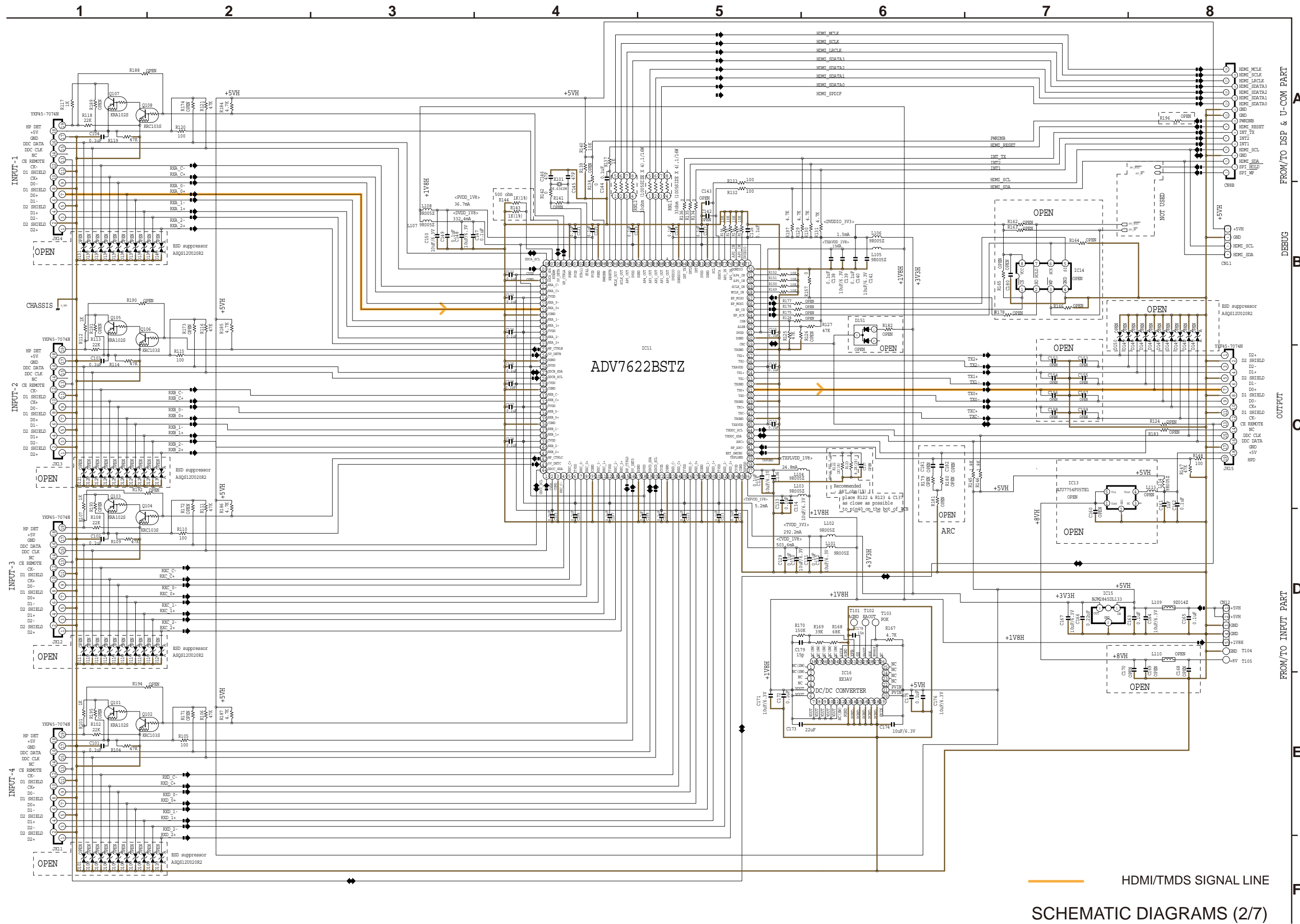

— HDMI/TMDS SIGNAL LINE
SCHEMATIC DIAGRAMS (2/7)

INPUT & VOLUME PART

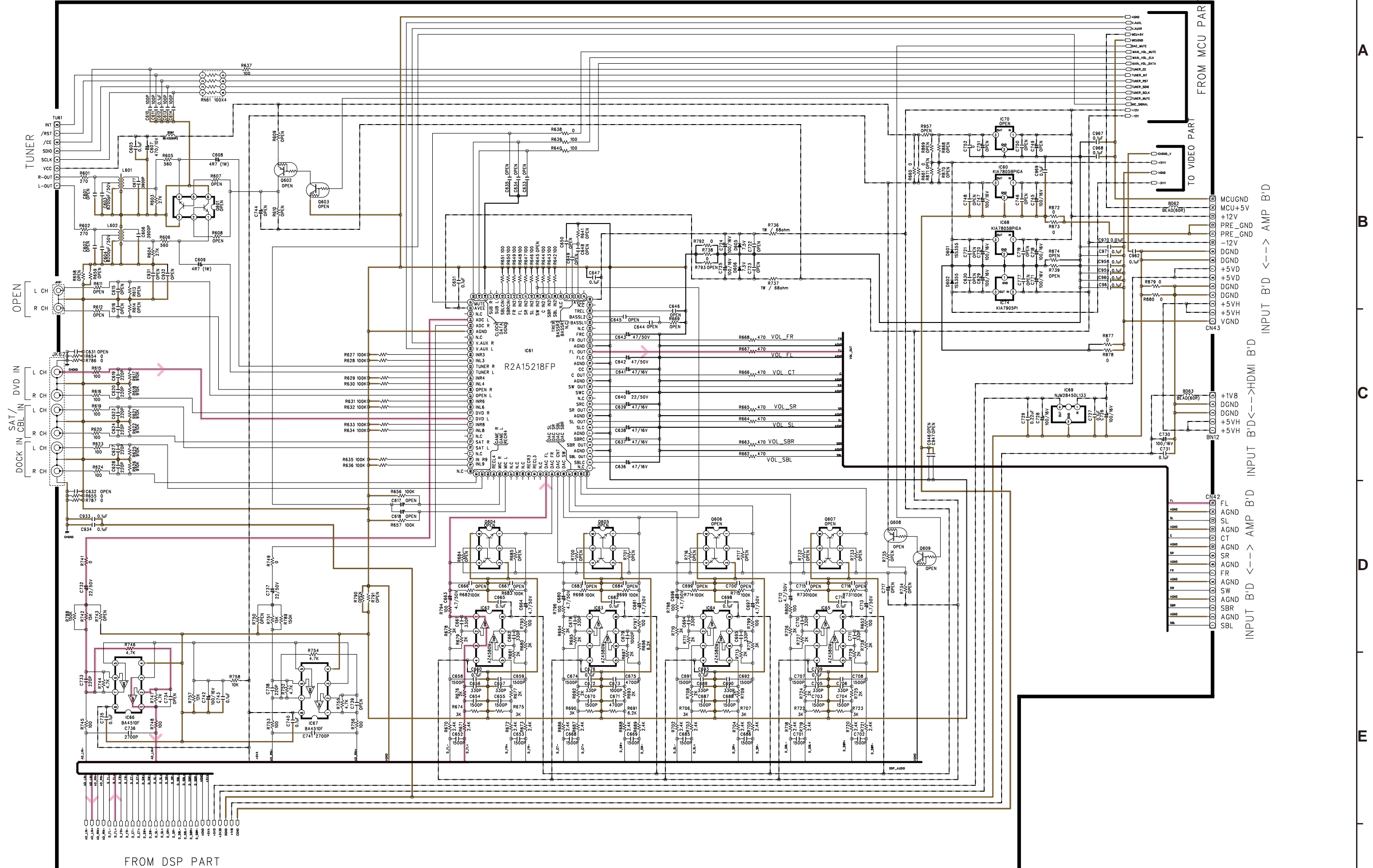

ANALOG AUDIO SIGNAL LINE
 SCHEMATIC DIAGRAMS (3/7)

VIDEO PART

TO FRONT B'D

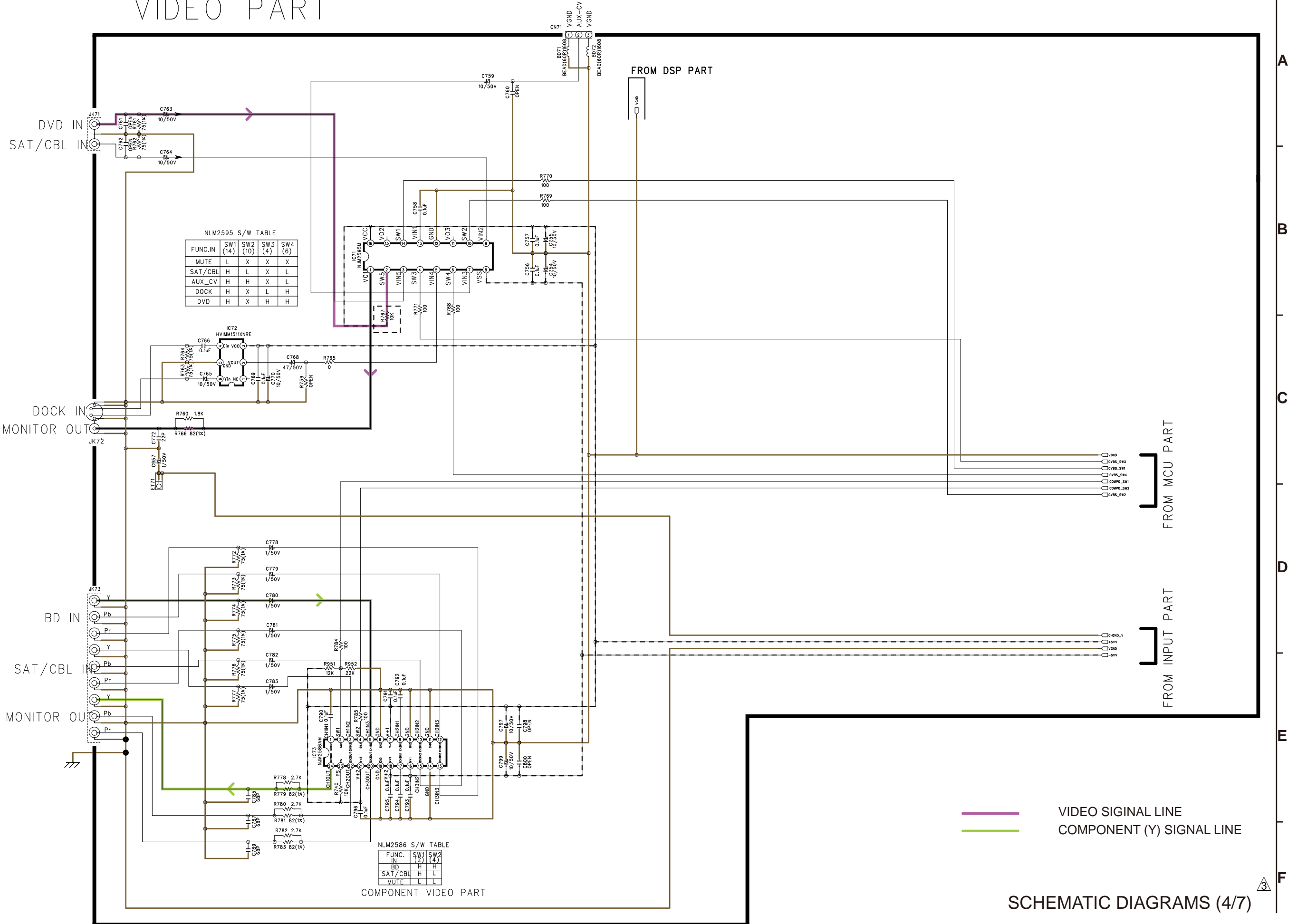

NLM2595 S/W TABLE

FUNC.IN	SW1 (14)	SW2 (10)	SW3 (4)	SW4 (6)
MUTE	L	X	X	X
SAT/CBL	H	L	X	L
AUX_CV	H	H	X	L
DOCK	H	X	L	H
DVD	H	X	H	H

NLM2586 S/W TABLE

FUNC.	SW1 IN	SW2 IN
BD	H	H
SAT/CBL	H	L
MUTE	L	L

FROM MCU PART

FROM INPUT PART

VIDEO SIGNAL LINE
COMPONENT (Y) SIGNAL LINE

DSP PART

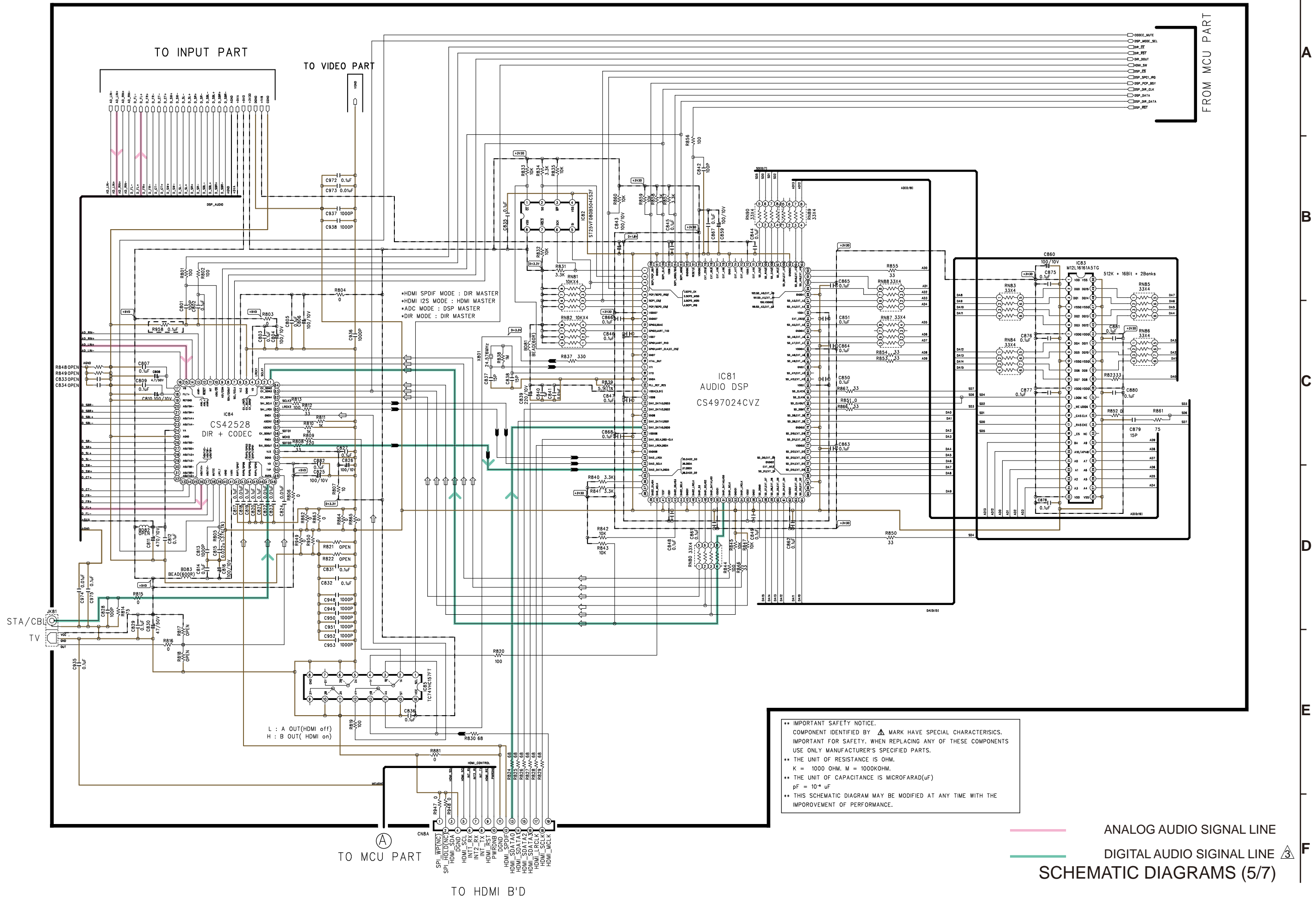

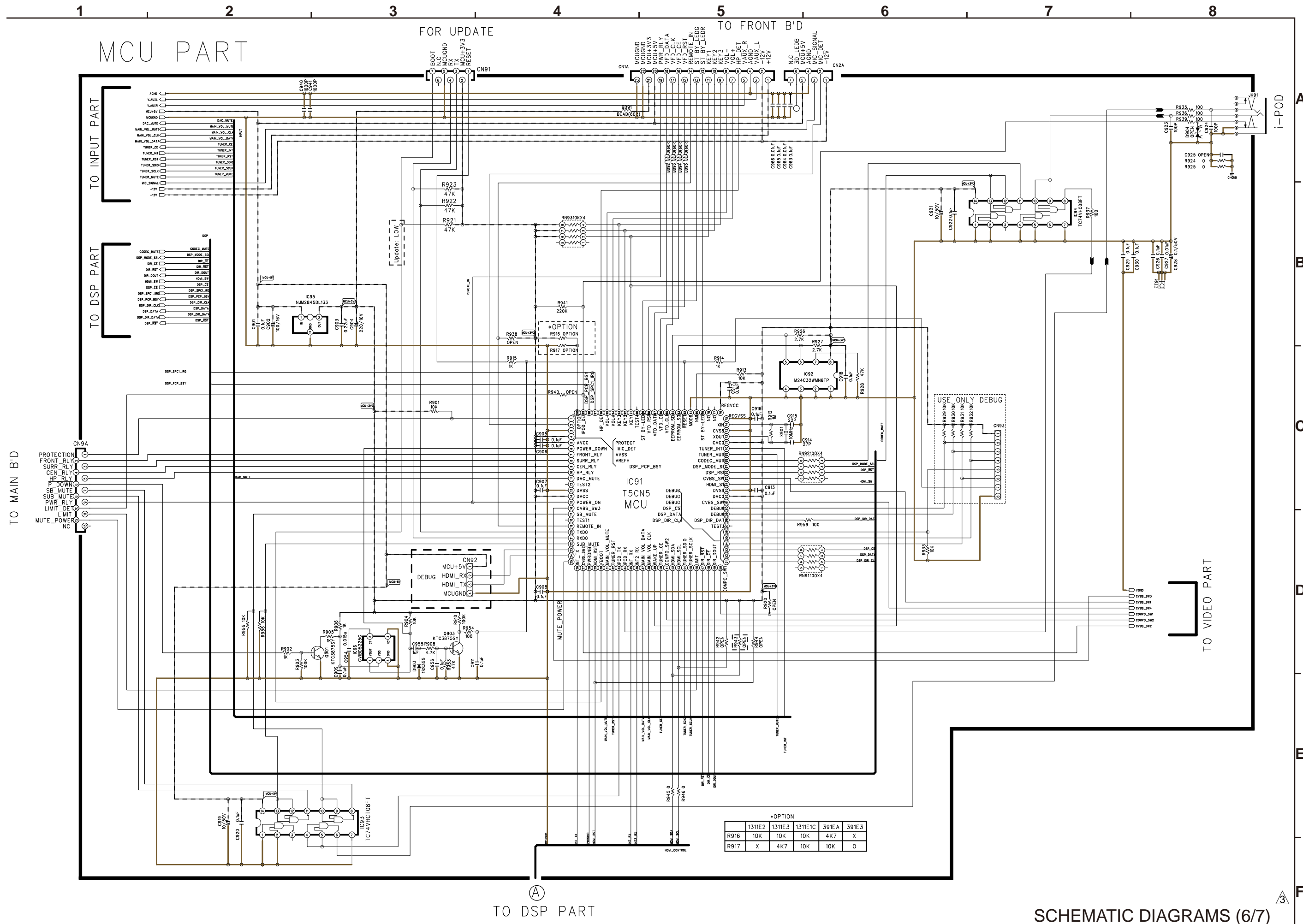

SCHEMATIC DIAGRAMS (6/7)

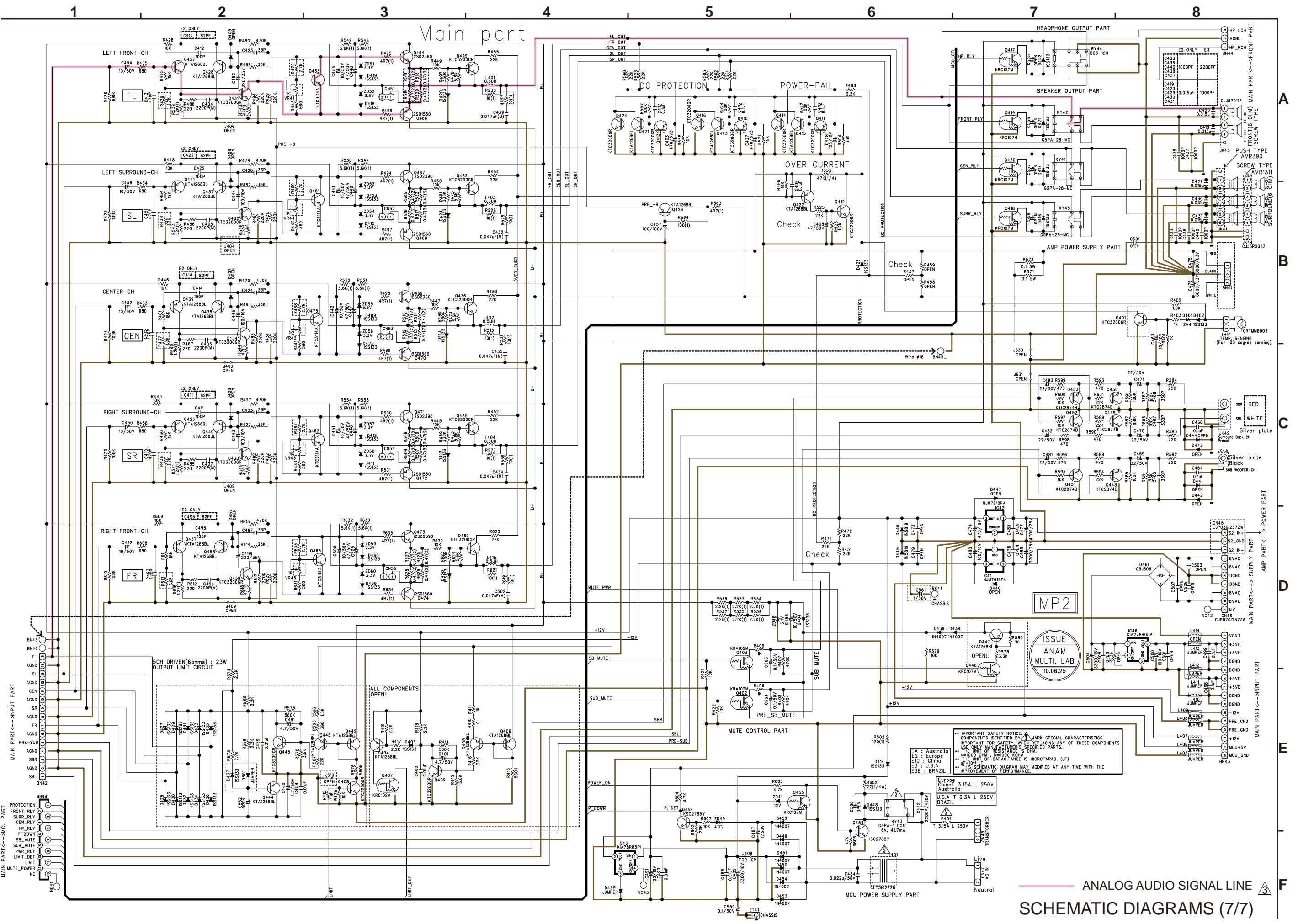

Main part

MP2

ISSUE
ANAM
MULTI. LAB
10.06.25

IMPORTANT SAFETY NOTICE:
COMPONENTS IDENTIFIED BY * MARK SPECIAL CHARACTERISTICS.
IMPORTANT FOR SAFETY, WHEN REPLACING ANY OF THESE COMPONENTS
USE ONLY MANUFACTURER'S SPECIFIED PARTS.
* = 1000 OHM, M = 1000 MICROH, μ = MICROFARAD. (μF)
= 10⁻⁴ μF
* THIS SCHEMATIC DIAGRAM MAY BE MODIFIED AT ANY TIME WITH THE
IMPROVEMENT OF PERFORMANCE.

EA : Australia
E2 : Europe
E3 : China
E4 : U.S.A
E5 : BRAZIL

Europe 3.15A L 250V
Australia
U.S.A T 6.3A L 250V
BRAZIL

ANALOG AUDIO SIGNAL LINE
SCHEMATIC DIAGRAMS (7/7)

WIRING DIAGRAM

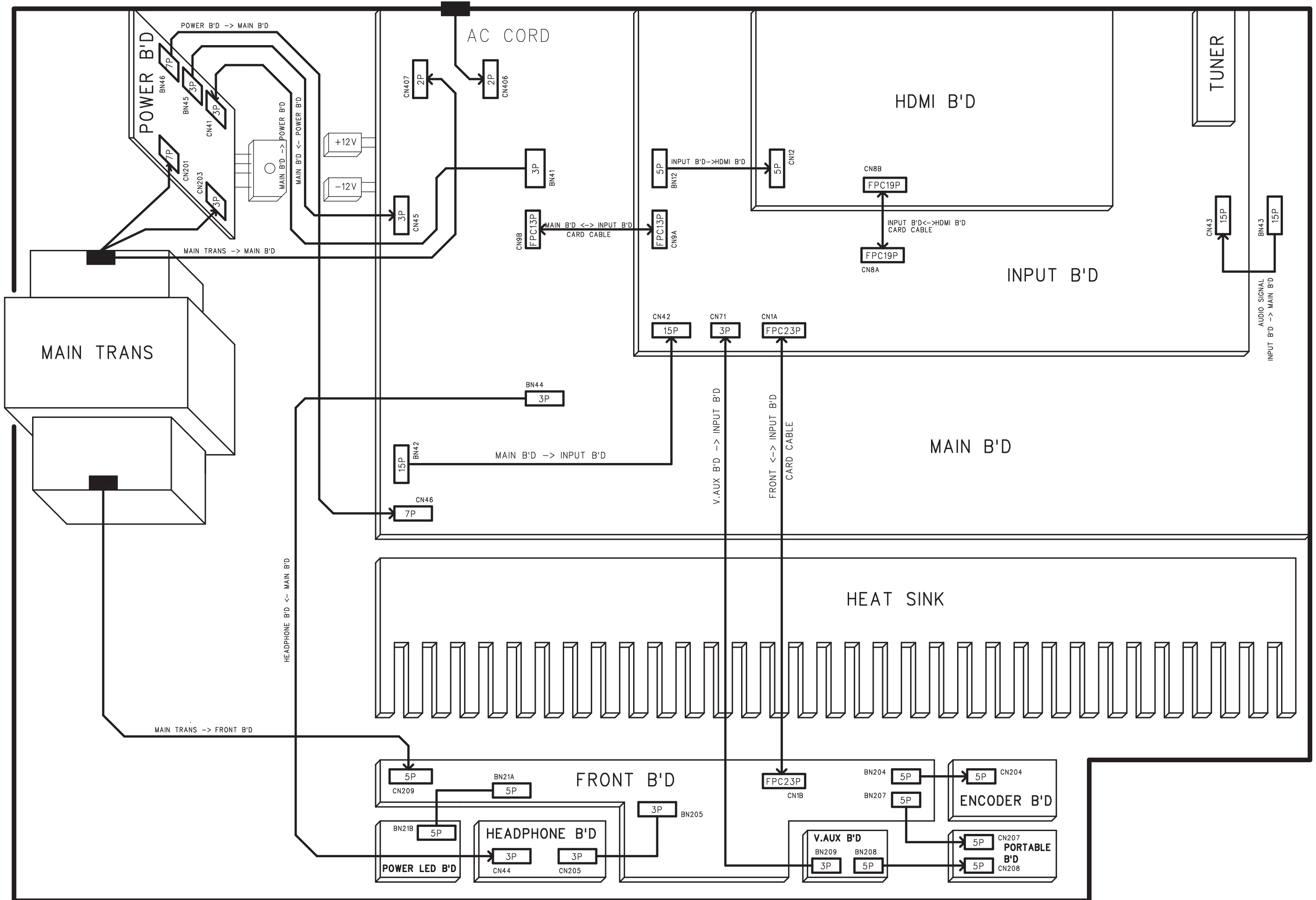

EXPLODED VIEW

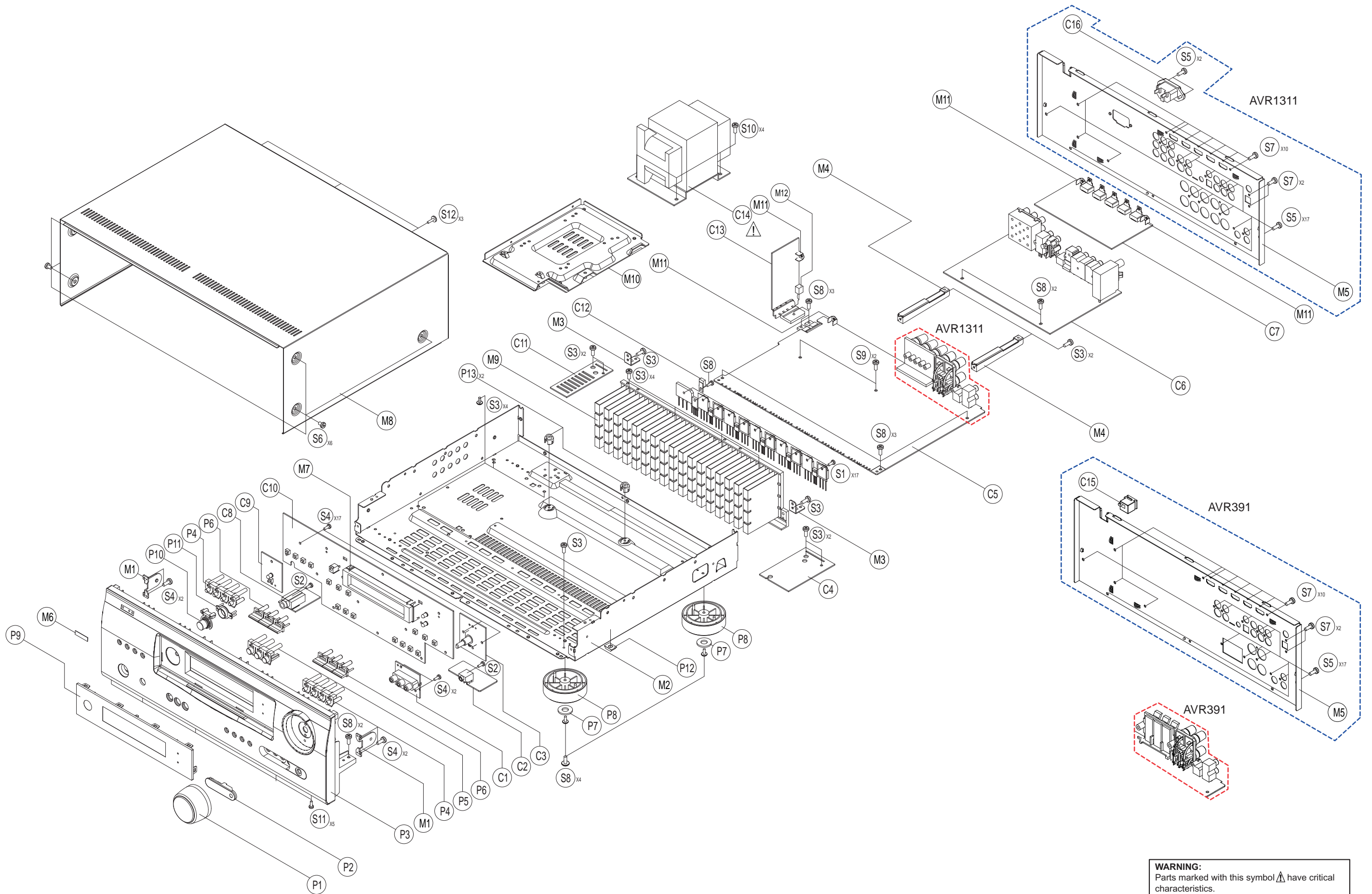

WARNING:
Parts marked with this symbol ⚠ have critical characteristics.
Use **ONLY** replacement parts recommended by the manufacturer.

PARTS LIST OF EXPLODED VIEW

* Parts for which "nsp" is indicated on this table cannot be supplied.

* P.W.B. ASS'Y for which "nsp" is indicated on this table cannot be supplied. When repairing the P.W.B. ASS'Y, check the board parts table and order replacement parts.

* Part indicated with the mark "★" is not illustrated in the exploded view.

* The parts listed below are for maintenance only, might differ from the parts used in the unit in appearances or dimensions.

Note: The symbols in the column "Remarks" indicate the following destinations.

1311E2 : Europe model

1311E1C : China model



391E3 : U.S.A. & Canada model

391E3B : Brazil model 

391EA : Australia model

BK : Black model

SP : Premium Silver model

Ref.No.	Part No.	Part Name	Remarks		Q'ty	New
C10'	nsp	FRONT P.W.B. UNIT ASS'Y		COP12291U		*
C10	nsp	FRONT UNIT				
C1	-	AUX UNIT				
C2	-	PHONE UNIT				
C3	-	VOLUME UNIT				
C9	-	POWER UNIT				
C8	-	HEADPHONE UNIT				
C13	-	REGULATOT UNIT				
C5'	nsp	MAIN P.W.B. UNIT ASS'Y	1311E2	COP12292E		*
C5'	nsp	MAIN P.W.B. UNIT ASS'Y	1311E1C	COP12292C		*
C5'	nsp	MAIN P.W.B. UNIT ASS'Y	391E3,391E3B	COP12292L		* 
C5'	nsp	MAIN P.W.B. UNIT ASS'Y	391EA	COP12292N		*
C5	-	MAIN UNIT				
C11	-	WIRE SUPPORT UNIT				
C6	nsp	INPUT P.W.B. UNIT ASS'Y	1311E2	COP12293E		*
C6	nsp	INPUT P.W.B. UNIT ASS'Y	1311E1C	COP12293C		*
C6	nsp	INPUT P.W.B. UNIT ASS'Y	391E3,391E3B	COP12293L		* 
C6	nsp	INPUT P.W.B. UNIT ASS'Y	391EA	COP12293N		*
C7	943189009470D	HDMI P.W.B. UNIT ASS'Y		COP12294U		*
P1	943412009840D	VOLUME KNOB	BK	CBN1A249	1	*
P1	943412009850D	VOLUME KNOB	SP	CBN1A249C73	1	*
P2	963419010060D	RCA COVER	BK	CGR1A510ZB28	1	
P2	963419011380D	RCA COVER	SP	CGR1A510YG45	1	
P3	943402009680D	FRONT PANEL	1311BKE2	CGW1A500B28Z	1	*
P3	943402009690D	FRONT PANEL	1311SPE2,1311SPE1C	CGW1A500RGG45Z	1	*
P3	943402009670D	FRONT PANEL	391BKE3,391BKE3B,391BKEA	CGW1A499B28Z	1	* 
P4	963411002810S	4KEY BUTTON	BK	CBT1A1138B28	2	
P4	963411002930S	4KEY BUTTON	SP	CBT1A1138G45	2	
P5	963411001410D	3KEYB BUTTON	BK	CBT1A1139B28Z	1	
P5	963411011340D	3KEYB BUTTON	SP	CBT1A1139G45Z	1	
P6	00D9630365002	WINE 3KEY BUTTON	BK	CBT1A1140B28	2	
P6	00D9630365301	WINE 3KEY BUTTON	SP	CBT1A1140G45	2	
P7	nsp	FOOT CUSHION		CHG2A289	4	
P8	943416009700D	FOOT		CKL2A093	4	
P9	943407009710D	FL WINDOW		CGU1A451Z	1	
P10	943411009860D	BUTTON STANDBY ASS'Y	BK	CBT1A1141ZA	1	*
P10	943411009870D	BUTTON STANDBY ASS'Y	SP	CBT1A1141YA	1	*
P11	00D9630137807	STANDBY LENS		CGL1A289	1	
P12	nsp	RUBBER		CHG1A113	1	

Ref.No.	Part No.	Part Name	Remarks		Q'ty	New	
P13	nsp	PCB HOLDER		CHE170	2		
M1	nsp	TOP BRACKET		CMD1A355	2		
M2	nsp	BOTTOM CHASSIS		CUA4A302	1		
M3	nsp	PCB BRACKET		CMD1A417	2		
M4	nsp	PCB BRACKET		CMD1A774	2		
M5	nsp	REAR PANEL	1311SPE2,1311BKE2	CKF4A437Z	1	*	
M5	nsp	REAR PANEL	1311SPE1C	CKF3A437Y	1	*	
M5	nsp	REAR PANEL	391BKE3	CKF1A437Z	1	*	
M5	nsp	REAR PANEL	391BKEA	CKF1A437Y	1	*	
M5	nsp	REAR PANEL	391BKE3B	CKF1A437X	1	*	
M6	00D1310158007	DENON BADGE(BLACK049)	BK	CGB1A140U	1		
M6	00D1310158010	DENON BADGE(SILVER052)	SP	CGB1A140T	1		
M7	nsp	FIP BRACKET		CMD1A572	2		
M8	00M07BW257010	TOP CABINET	BK	CKC2A155K117	1		
M8	943403002040M	TOP CABINET	SP	CKC1A155D11	1		
M9	nsp	HEAT SINK		CMY8A161	1		
M10	nsp	TRANS BRACKET		CMD2A675	1		
M11	nsp	PCB BRACKET		CMD1A569	4		
M12	nsp	PCB BRACKET		CMD1A188	1		
C12	943252010310S	POSISTOR ASS'Y (100)		CRTDHTS100180W	1		
△	C14	943101009650D	POWER TRANS	1311SPE2,1311BKE2, 391BKEA	CLT5U042ZE	1	*
△	C14	943101009660D	POWER TRANS	1311SPE1C	CLT5U042ZH	1	*
△	C14	943101009640D	POWER TRANS	391BKE3,391BKE3B	CLT5U042ZU	1	*
C15	nsp	CORD BUSHING		KHR1A028	1		
C16	00MYJ04002640	AC RECEPTACLE(15A/250V,R-301,B21)	1311BKE2,1311SPE2	CJJ8A006ZW			
★ H1	nsp	WIRE ASS'Y 2P(100MM)	1311SPE2,1311BKE2	CWZPM5003TW91A	1		
★ H2	943606009880D	CARD CABLE		CWC4C4A13B120B	1	*	
★ H3	943606009890D	CARD CABLE(Shield,105C)		CWC4C4A23B220B08S	1	*	
★ H4	943606009900D	CARD CABLE		CWC6C4A19B100B10	1	*	
★ H5	nsp	FERRITE RING		CLZ9W003Z	1		
★ H6	nsp	FERRITE CORE RINGTYPE		CLZ9Z004Y	1		
★ H7	nsp	FERRITE CORE		CLZ9Z071Z	1		
★ H8	nsp	CLAMPER		CHR301	7		
★ H9	nsp	TAPE HEMELON		CHS1A032	3		
★ H10	606050028012P	(7)P FFC(1.0)		606050028012P	1		
SCREWS							
S1	nsp	SPECIAL SCREW		CHD1A012R	17		
S2	nsp	SCREW		CTWS3+10GR	2		
S3	nsp	SCREW		CTB3+6JR	18		
S4	nsp	SCREW		CTBD3+10JR	23		
S5	nsp	SCREW	1311BKE2,1311SPE2, 1311SPE1C	CTBD3+8JFZR	19		
S5	nsp	SCREW	391BKE3,391BKE3B,391BKEA	CTBD3+8JFZR	17	△	
S6	nsp	SCREW	BK	CTWD4+6FFZR	6		
S6	nsp	SCREW	SP	CTWD4+6FFN	6		
S7	nsp	SCREW		CTB3+6FFZR	12		
S8	nsp	SCREW		CTW3+8JR	15		

Ref.No.	Part No.	Part Name	Remarks		Q'ty	New
S9	nsp	SCREW		CTW3+12JR	2	
S10	nsp	SPECIAL SCREW		CHD1A023R	4	
S11	nsp	SCREW	BK	CTB3+8JFZR	5	
S11	nsp	SCREW	SP	CTB3+8JFN	5	
S12	nsp	SCREW	BK	CTBD3+8JFZR	3	
S12	nsp	SCREW	SP	CTBD3+8JFN	3	

PACKING VIEW (for AVR-1311, 391)

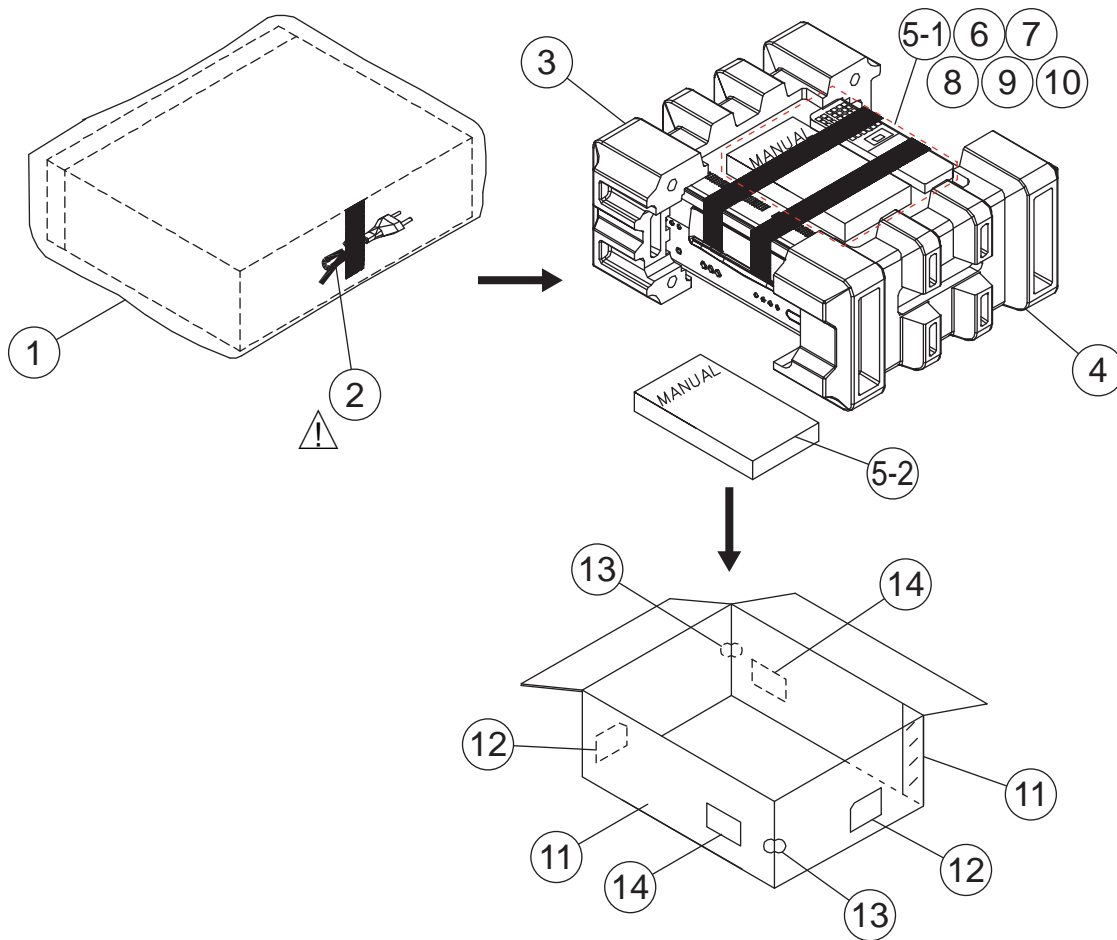

PARTS LIST OF PACKING & ACCESSORIES (for AVR-1311, 391)

* Parts for which "nsp" is indicated on this table cannot be supplied.

* Part indicated with the mark "★" is not illustrated in the exploded view.

* The parts listed below are for maintenance only, might differ from the parts used in the unit in appearances or dimensions.

Note: The symbols in the column "Remarks" indicate the following destinations.

1311E2 : Europe model

1311E1C : China model

391E3 : U.S.A. & Canada model

391EA : Australia model

BK : Black model

SP : Premium Silver model

Ref.No.	Part No.	Part Name	Remarks	Q'ty	New
1	nsp	POLYSET BAG		1	
⚠	90M-ZC000320R	POWER CORD	1311SPE2,1311BKE2	1	
⚠	90M-YC000790R	POWER CORD	1311SPE1C	1	
⚠	90M-YC000780R	POWER CORD	391BKE3	1	
⚠	943611010020S	POWER CORD	391BKEA	1	
3	943533009560D	SNOW PAD(L)		1	*
4	943533009570D	SNOW PAD(R)		1	*
5-1	541110486002D	INSTRUCTION MANUAL A	1311SPE2,1311BKE2	1	*
5-2	541110603005D	INSTRUCTION MANUAL B	1311SPE2,1311BKE2	1	*
5-1	541110488008D	INSTRUCTION MANUAL	1311SPE1C	1	*
5-1	541110484006D	INSTRUCTION MANUAL	391BKE3	1	*
5-1	541110489001D	INSTRUCTION MANUAL	391BKEA	1	*
6	307010085006D	REMOCON TRANSMITER ASS'Y		1	*
7	nsp	BATTERY (SIZE 'AAA')		2	

Ref.No.	Part No.	Part Name	Remarks		Q'ty	New
8	00D9430113403	FM 1 POLE ANT.	1311SPE2,1311BKE2, 1311SPE1C,391BKEA	CSA1A018Z	1	
8	90M-ZA000230R	FM 1 POLANT(UL)	391BKE3	CSA1A019Z	1	
9	943116009500S	AM LOOP ANT		CSA1A032Z	1	
10	nsp	POLY BAG		CPB1061W	1	
11	943531009950D	OUTCARTON BOX	1311SPE2,1311BKE2	CPG1A924X	1	*
11	943531009960D	OUTCARTON BOX	1311SPE1C	CPG1A924V	1	*
11	943531009520D	OUTCARTON BOX	391BKE3,391BKEA	CPG1A924Z	1	*
12	nsp	CONTROL LABEL		CQB1A993Z	2	
13	nsp	COLOR LABEL	1311SPE2,1311SPE1C	CQB1A 676	2	
14	nsp	PHOTO LABEL B	391BKE3	CQB1A1010Z	2	

PACKING VIEW (for DHT-1311XP, 391XP)

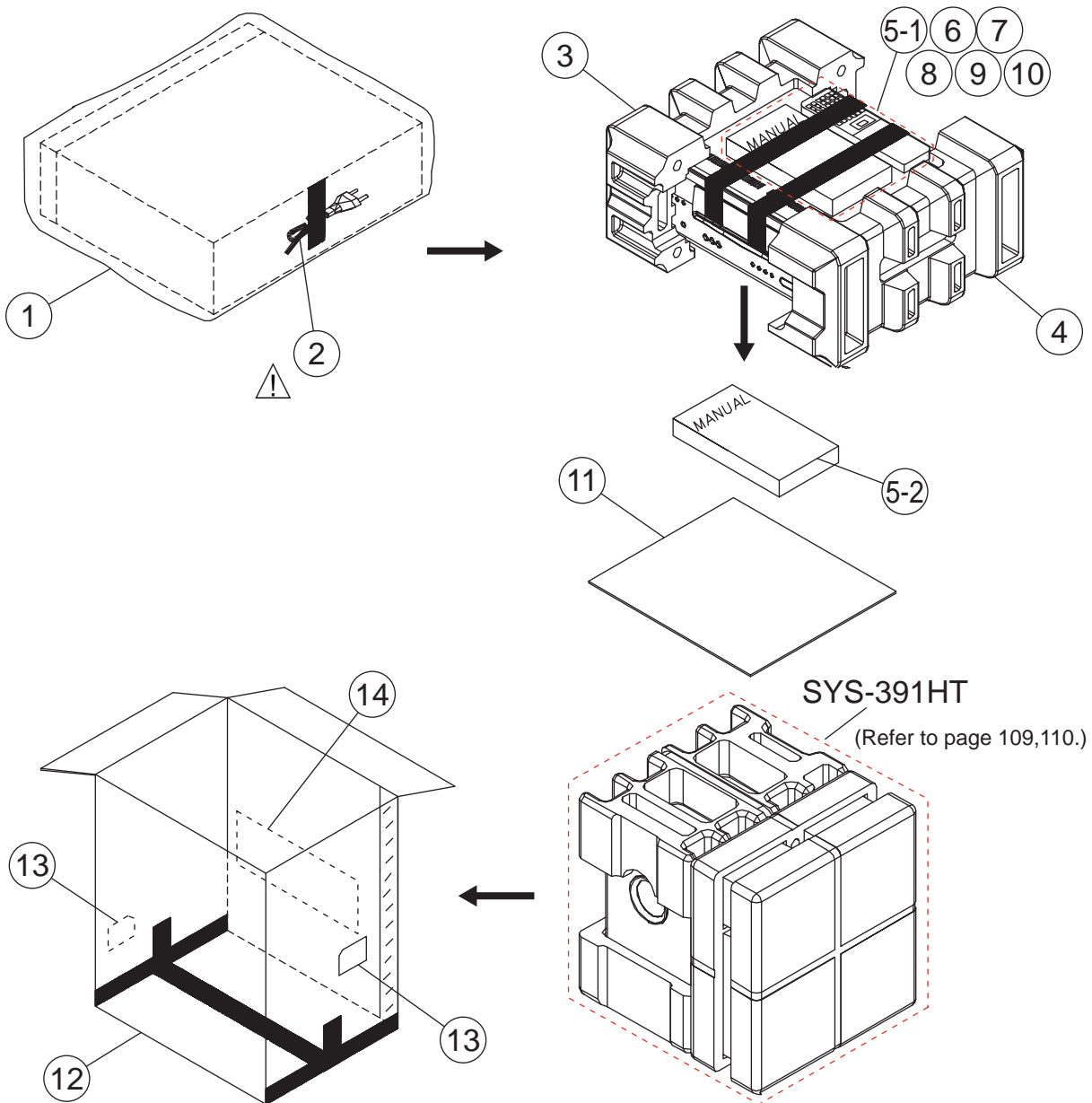

PARTS LIST OF PACKING & ACCESSORIES (for DHT-1311XP, 391XP)

* Parts for which "nsp" is indicated on this table cannot be supplied.

* Part indicated with the mark "★" is not illustrated in the exploded view.

* The parts listed below are for maintenance only, might differ from the parts used in the unit in appearances or dimensions.

Note: The symbols in the column "Remarks" indicate the following destinations.

1311E2 : Europe model

391E3 : U.S.A. & Canada model

391E3B : Brazil model ⚠

391EA : Australia model

BK : Black model

	Ref.No.	Part No.	Part Name	Remarks		Q'ty	New
	1	nsp	POLYSET BAG		CPP1A081Z	1	
⚠	2	90M-ZC000320R	POWER CORD	1311BKE2	CJA2B054Z	1	
⚠	2	90M-YC000780R	POWER CORD	391BKE3	CJA523FBYA	1	
⚠	2	943611010020S	POWER CORD	391BKEA	CJA2H116Z	1	
⚠	2	943611011130D	POWER CORD	391BKE3B	CJA2F118Z	1	⚠
	3	943533009930D	SNOW PAD(L)		CPS1A882	1	*

Ref.No.	Part No.	Part Name	Remarks		Q'ty	New
4	943533009940D	SNOW PAD(R)		CPS1A883	1	*
5-1	541110486002D	INSTRUCTION MANUAL A	1311SPE2,1311BKE2	CQX1A1538Z	1	*
5-2	541110603005D	INSTRUCTION MANUAL B	1311SPE2,1311BKE2	CQX1A1538Y	1	*
5-1	541110484006D	INSTRUCTION MANUAL	391BKE3,391BKE3B	CQX1A1537Z	1	*
5-1	541110489001D	INSTRUCTION MANUAL	391BKEA	CQX1A1541Z	1	*
6	307010085006D	REMOCON TRANSMITER ASS'Y		CARTAVR1311	1	*
7	nsp	BATTERY (SIZE 'AAA')		CABR03PPB	2	
8	00D9430113403	FM 1 POLE ANT.	1311BKE2,391BKEA	CSA1A018Z	1	
8	90M-ZA000230R	FM 1 POLANT(UL)	391BKE3,391BKE3B	CSA1A019Z	1	
9	943116009500S	AM LOOP ANT		CSA1A032Z	1	
10	nsp	POLY BAG		CPB1061W	1	
11	943537009980D	OUTCARTON BOX		CPG1A929	1	*
12	943531009990D	OUTCARTON BOX	1311BKE2	CPG1A925X	1	*
12	943531010000D	OUTCARTON BOX	391BKE3,391BKE3B,391BKEA	CPG1A925Z	1	*
13	nsp	COLOR LABEL		CQB1A993Z	2	
14	nsp	PHOTO LABEL A	391BKE3,391BKE3B	CQB1A1000Z	2	

SEMICONDUCTORS

Only major semiconductors are shown, general semiconductors etc. are omitted to list.
 The semiconductor which described a detailed drawing in a schematic diagram are omitted to list.

1. IC's

R2A15218FP (INPUT :IC61)

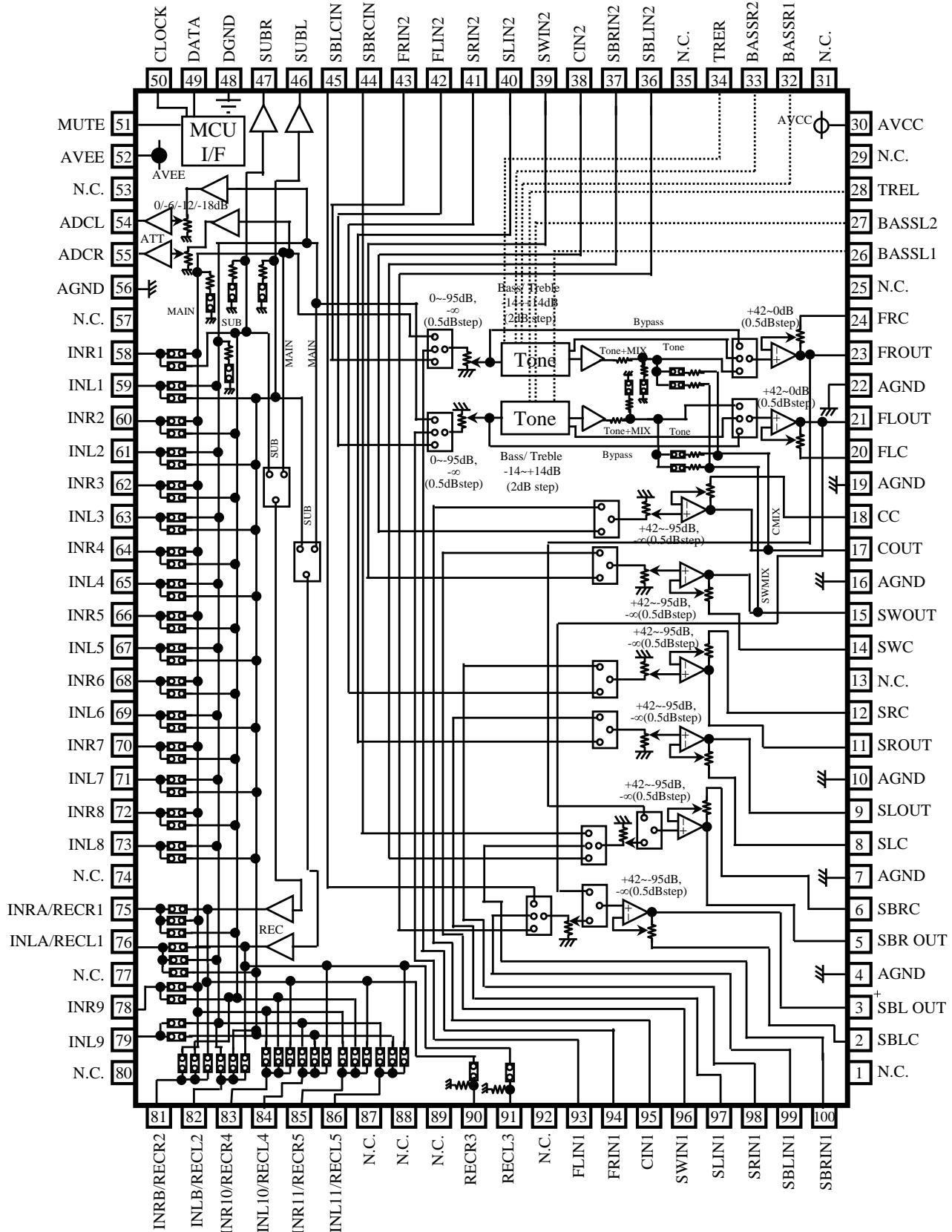

R2A15218FP Terminal Functions

PIN No.	Name	Function
23,21, 17,15, 11,9, 5,3	FROUT,FLOUT, COUT,SWOUT, SROUT, SLOUT, SBROUT,SBLOUT	Output pin of FL/FR/C/SW/SL/SR/SBL/SBR channel
24,20, 18,14, 12,8, 6,2	FRC,FLC, CC,SWC, SRC,SLC, SBRC,SBLC	Connects capacitor for reducing click noise of L/R/C/SW/SL/SR/SBL/SBR channel volume
4,7,10,16, 19,22,56	AGND	Analog ground of internal circuit
28,34	TREL, TRER	Frequency characteristic setting pin of L/R channel tone control (Treble)
26,27, 32,33	BASSL1,BASSL2 BASSR1,BASSR2	Frequency characteristic setting pin of L/R channel tone control (Bass)
30	AVCC	Positive power supply to internal circuit
43,42, 41,40, 39,38, 37,36	FRIN2, FLIN2, SRN2,SLIN2, SWIN2,CIN2, SBRIN2,SBLIN2	Input pin of L/R/C/SW/SL/SR/SBL/SBR channel (Multi IN 1/2)
93,94, 95,96, 97,98, 99,100	FLIN1, FRIN1, CIN1,SWIN1, SLIN1,SRIN1, SBLIN1,SBRIN1	
48	DGND	Digital ground of internal circuit
49	DATA	Input pin of control data
50	CLOCK	Input pin of control clock
52	AVEE	Negative power supply to internal circuit
59,61,63, 65,67,69, 71,73,79	INL1,INL2, INL3, INL4,INL5,INL6, INL7,INL8,INL9	Input pin of L/R channel (Input Selector)
58,60,62, 64,66,68, 70,72,78	INR1,INR2, INR3, INR4,INR5,INR6, INR7,INR8,INR9	
51	MUTE	Outside Mute Control PIN
44,45	SBRCIN,SBLCIN	Input pin for SBL/SBR channel Volume
46,47	SUBL,SUBR	Output pin for L/R channel SUB Output
54,55	ADCL, ADCR	Output pin for L/R channel ADC
90,91	RECR3,RECL3	Output pin for L/R channel REC Output
75,76, 81,82, 83,84, 85,86	INRA/RECR1,INLA/RECL1, INRB/RECR2,INLB/RECL2, INR10/RECR4,INL10/RECL4, INR11/RECR5,INL11/RECL5	Input pin of L/R channel (Input Selector)/ Output pin for L/R channel REC Output
1,13,25,29,31, 35,53, 57,74,77,80, 87,88,89,92	N.C.	No Connected PIN

NJM2595M (INPUT : IC71)

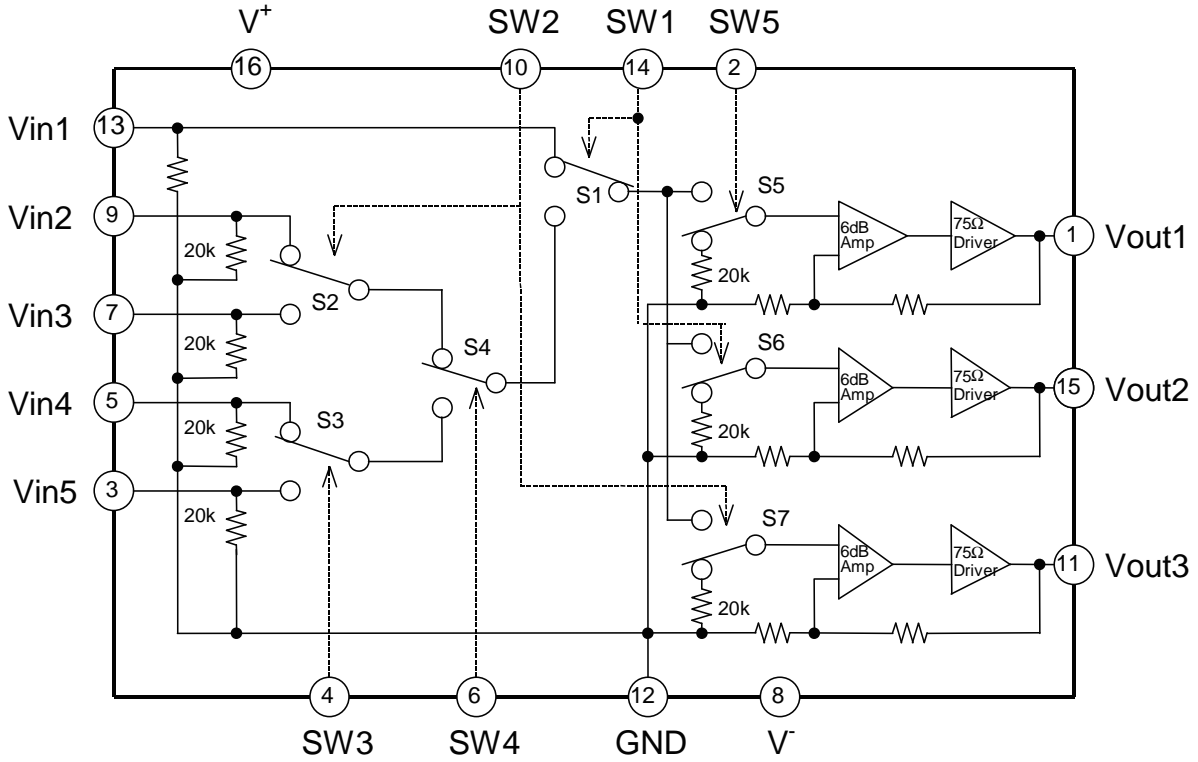

NJM2586M (INPUT : IC73)

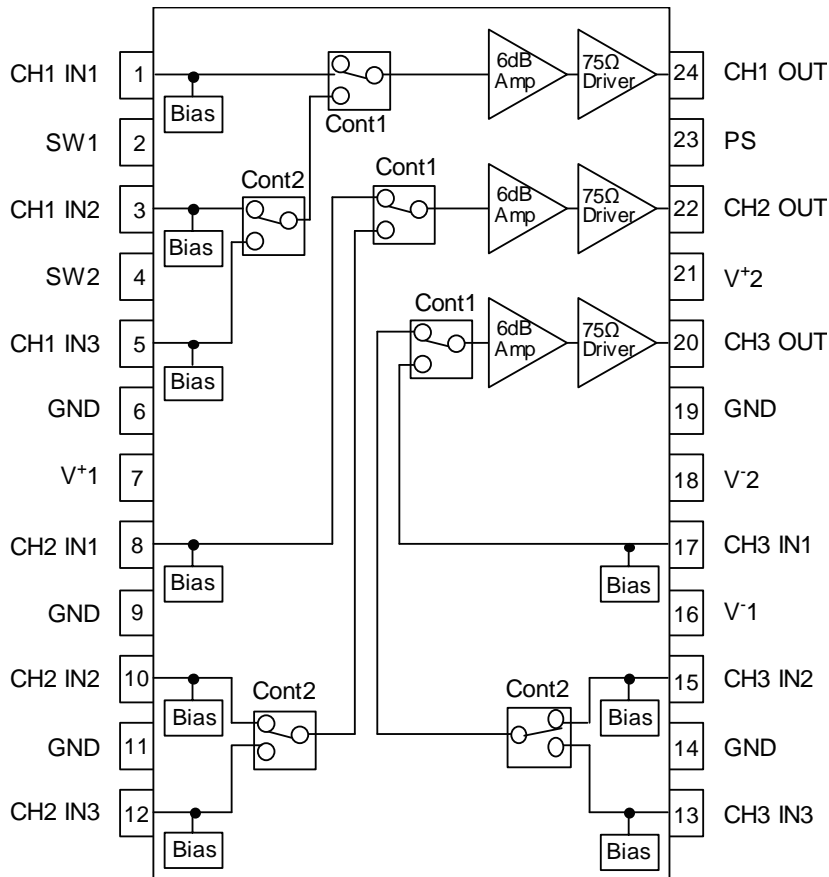

CS42528 (INPUT : IC84)

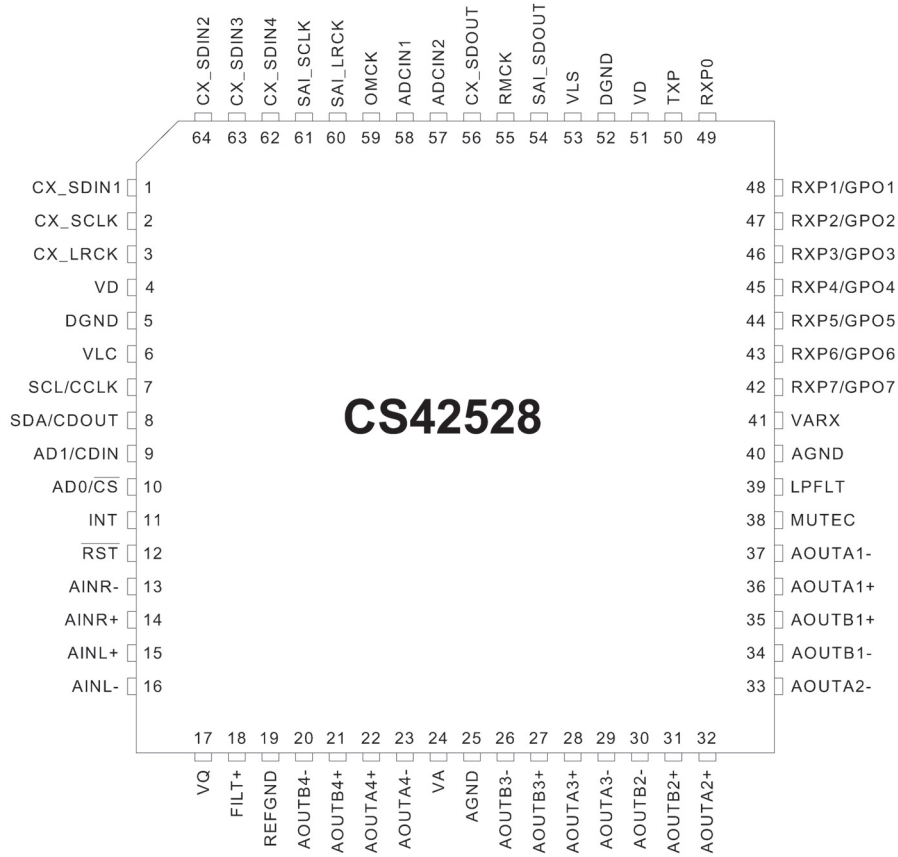

CS42528 Block diagram

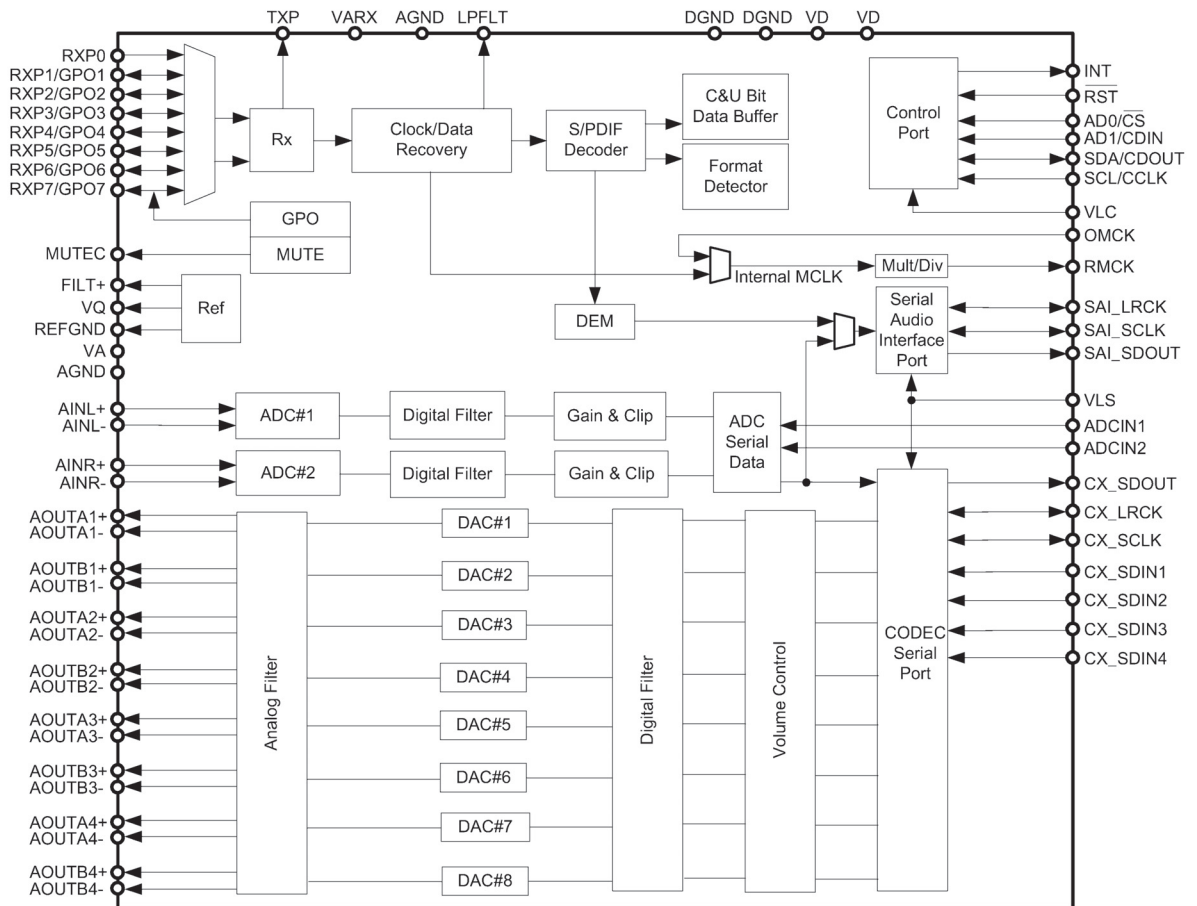

CS42528 Terminal Functions

INT	11	Interrupt (Output) - The CS42528 will generate an interrupt condition as per the Interrupt Mask register. See "Interrupts" on page 40 for more details.
$\overline{\text{RST}}$	12	Reset (Input) - The device enters a low power mode and all internal registers are reset to their default settings when low.
AINR- AINR+	13 14	Differential Right Channel Analog Input (Input) - Signals are presented differentially to the delta-sigma modulators via the AINR+/- pins.
AINL+ AINL-	15 16	Differential Left Channel Analog Input (Input) - Signals are presented differentially to the delta-sigma modulators via the AINL+/- pins.
VQ	17	Quiescent Voltage (Output) - Filter connection for internal quiescent reference voltage.
FILT+	18	Positive Voltage Reference (Output) - Positive reference voltage for the internal sampling circuits.
REFGND	19	Reference Ground (Input) - Ground reference for the internal sampling circuits.
AOUTA1 +,- AOUTB1 +,- AOUTA2 +,- AOUTB2 +,- AOUTA3 +,- AOUTB3 +,- AOUTA4 +,- AOUTB4 +,-	36,37 35,34 32,33 31,30 28,29 27,26 22,23 21,20	Differential Analog Output (Output) - The full-scale differential analog output level is specified in the Analog Characteristics specification table.
VA VARX	24 41	Analog Power (Input) - Positive power supply for the analog section.
AGND	25 40	Analog Ground (Input) - Ground reference. Should be connected to analog ground.
MUTEC	38	Mute Control (Output) - The Mute Control pin outputs high impedance following an initial power-on condition or whenever the PDN bit is set to a '1', forcing the codec into power-down mode. The signal will remain in a high impedance state as long as the part is in power-down mode. The Mute Control pin goes to the selected "active" state during reset, muting, or if the master clock to left/right clock frequency ratio is incorrect. This pin is intended to be used as a control for external mute circuits to prevent the clicks and pops that can occur in any single supply system. The use of external mute circuits are not mandatory but may be desired for designs requiring the absolute minimum in extraneous clicks and pops.
LPFLT	39	PLL Loop Filter (Output) - An RC network should be connected between this pin and ground.
RXP7/GPO7 RXP6/GPO6 RXP5/GPO5 RXP4/GPO4 RXP3/GPO3 RXP2/GPO2 RXP1/GPO1	42 43 44 45 46 47 48	S/PDIF Receiver Input/ General Purpose Output (Input/Output) - Receiver inputs for S/PDIF encoded data. The CS42528 has an internal 8:2 multiplexer to select the active receiver port, according to the Receiver Mode Control 2 register. These pins can also be configured as general purpose output pins, ADC Overflow indicators or Mute Control outputs according to the RXP/General Purpose Pin Control registers.
RXP0	49	S/PDIF Receiver Input (Input) - Dedicated receiver input for S/PDIF encoded data.
TXP	50	S/PDIF Transmitter Output (Output) - S/PDIF encoded data output, mapped directly from one of the receiver inputs as indicated by the Receiver Mode Control 2 register.
VLS	53	Serial Port Interface Power (Input) - Determines the required signal level for the serial port interfaces.
SAI_SDOUT	54	Serial Audio Interface Serial Data Output (Output) - Output for two's complement serial audio PCM data from the S/PDIF incoming stream. This pin can also be configured to transmit the output of the internal and external ADCs.
RMCK	55	Recovered Master Clock (Output) - Recovered master clock output from the External Clock Reference (OMCK, pin 59) or the PLL which is locked to the incoming S/PDIF stream or CX_LRCK.
CX_SDOUT	56	CODEC Serial Data Output (Output) - Output for two's complement serial audio data from the internal and external ADCs.
ADCIN1 ADCIN2	58 57	External ADC Serial Input (Input) - The CS42528 provides for up to two external stereo analog to digital converter inputs to provide a maximum of six channels on one serial data output line when the CS42528 is placed in One-Line Mode.
OMCK	59	External Reference Clock (Input) - External clock reference that must be within the ranges specified in the register "OMCK Frequency (OMCK Freqx)" on page 53.
SAI_LRCK	60	Serial Audio Interface Left/Right Clock (Input/Output) - Determines which channel, Left or Right, is currently active on the serial audio data line.
SAI_SCLK	61	Serial Audio Interface Serial Clock (Input/Output) - Serial clock for the Serial Audio Interface.

CS497024CVZ (INPUT : IC81)

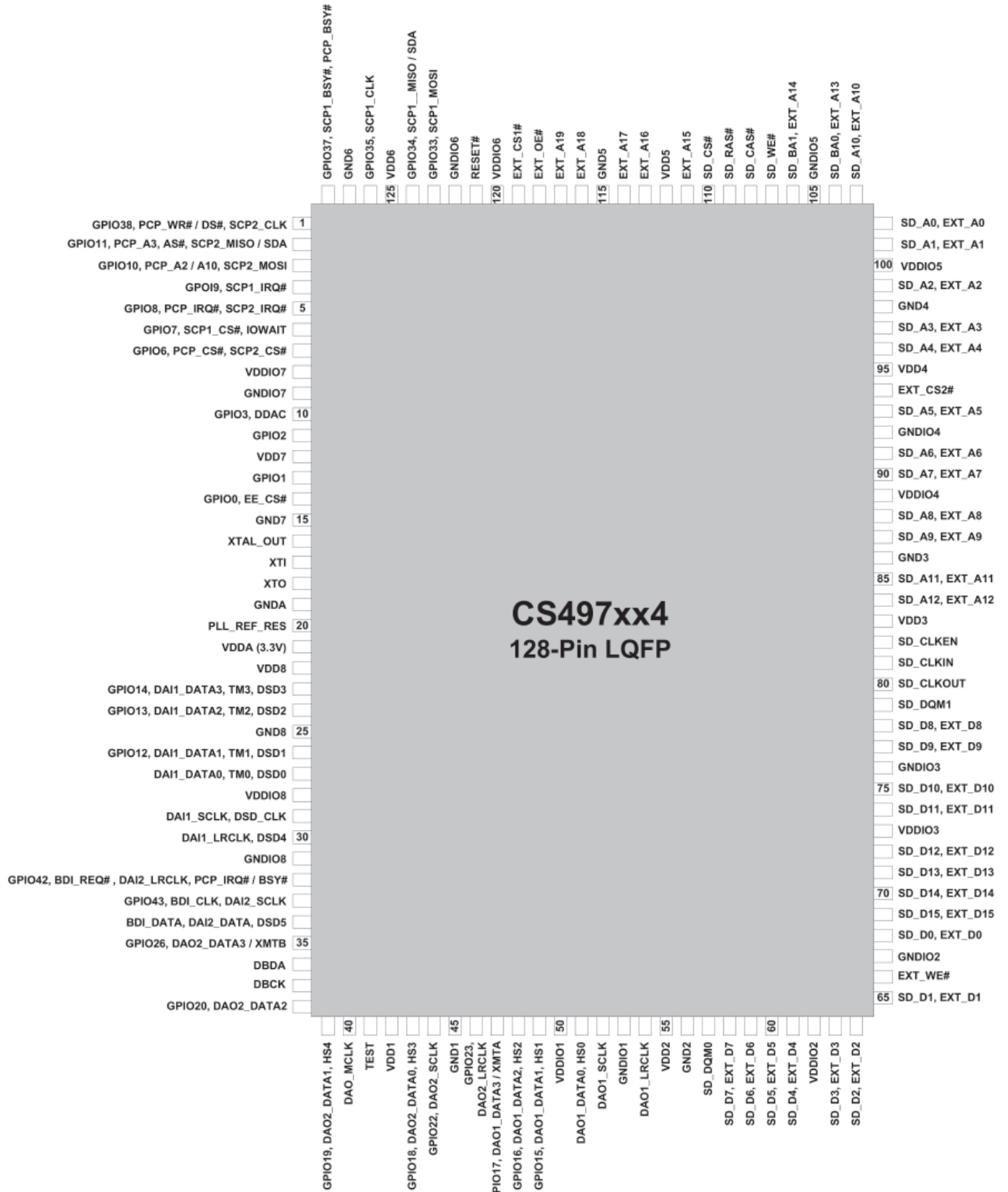

CS497024CVZ Block diagram

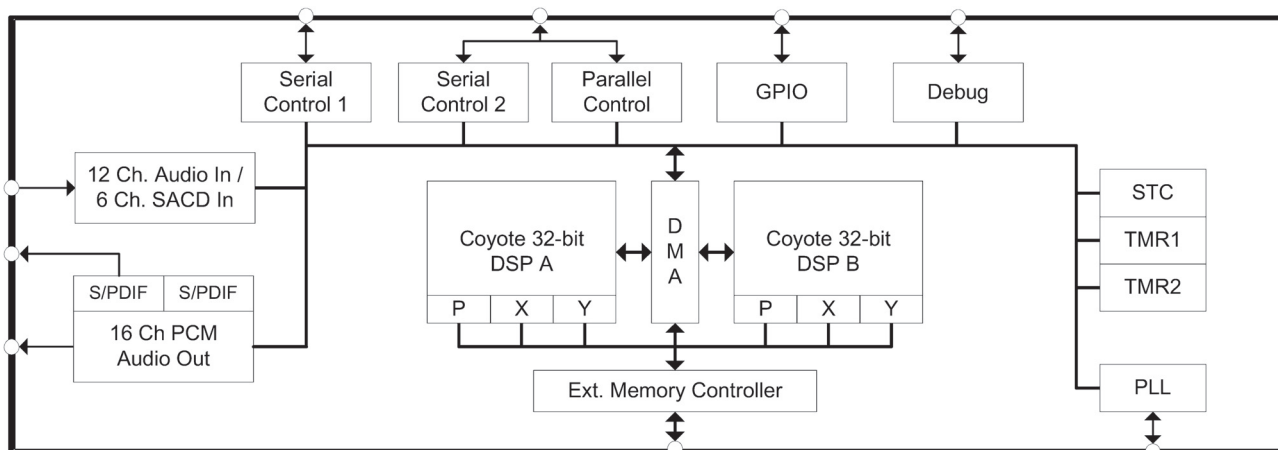

M12L16161A5TG (INPUT : IC83)

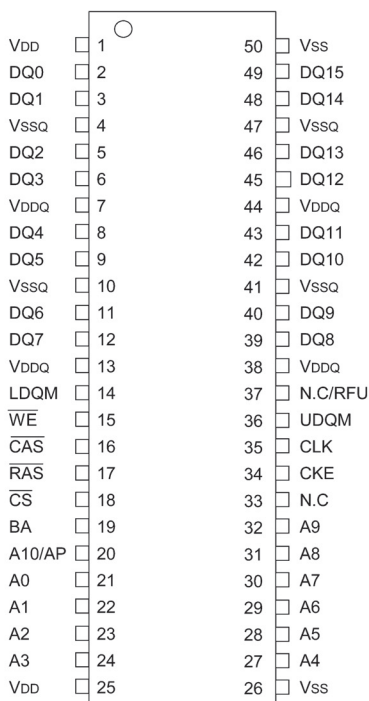

BLOCK DIAGRAM

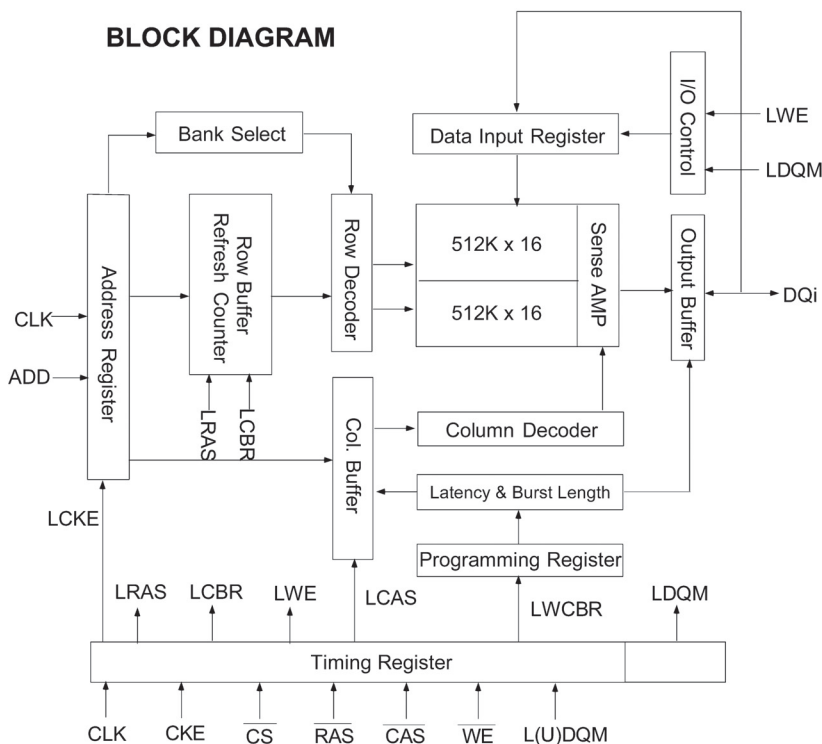

PIN FUNCTION DESCRIPTION

Pin	Name	Input Function
CLK	System Clock	Active on the positive going edge to sample all inputs.
CS	Chip Select	Disables or enables device operation by masking or enabling all inputs except CLK, CKE and L(U)DQM.
CKE	Clock Enable	Masks system clock to freeze operation from the next clock cycle. CKE should be enabled at least one cycle prior to new command. Disable input buffers for power down in standby.
A0 ~ A10/AP	Address	Row / column addresses are multiplexed on the same pins. Row address : RA0 ~ RA10, column address : CA0 ~ CA7
BA	Bank Select Address	Selects bank to be activated during row address latch time. Selects bank for read/write during column address latch time.
RAS	Row Address Strobe	Latches row addresses on the positive going edge of the CLK with RAS low. Enables row access & precharge.
CAS	Column Address Strobe	Latches column addresses on the positive going edge of the CLK with CAS low. Enables column access.
WE	Write Enable	Enables write operation and row precharge. Latches data in starting from CAS, WE active.
L(U)DQM	Data Input / Output Mask	Makes data output Hi-Z, tSHZ after the clock and masks the output. Blocks data input when L(U)DQM active.

TC74VHC157FT (INPUT : IC85)

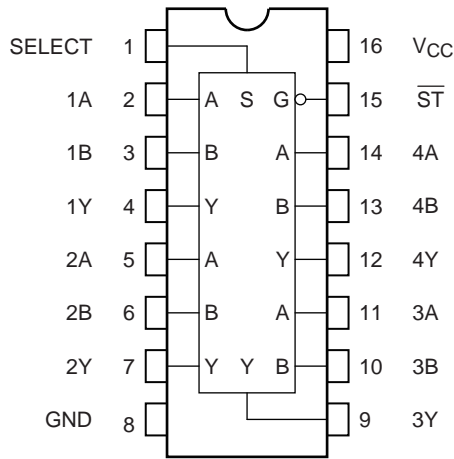

T5CN5 (INPUT : IC91)

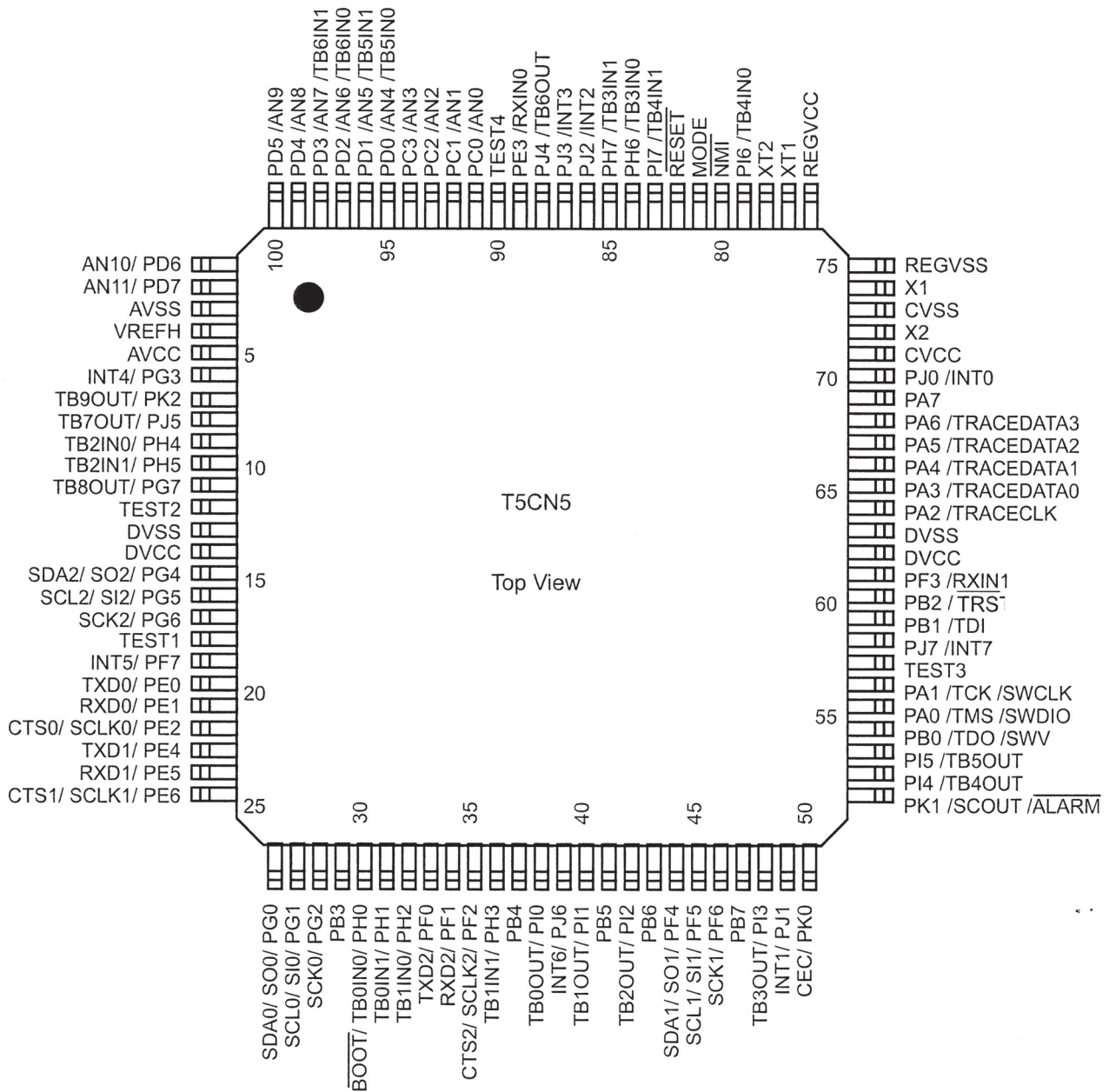

T5CN5 Terminal Functions

Pin No.	Pin name	Pin No.	Pin name
1	PD6, AN10	26	PG0, SO0, SDA0
2	PD7, AN11	27	PG1, SI0, SCL0
3	AVSS	28	PG2, SCK0
4	VREFH	29	PB3
5	AVCC	30	PH0, TB0IN0, $\overline{BOO1}$
6	PG3, INT4	31	PH1, TB0IN1
7	PK2, TB9OUT	32	PH2, TB1IN0
8	PJ5, TB7OUT	33	PF0, TXD2
9	PH4, TB2IN0	34	PF1, RXD2
10	PH5, TB2IN1	35	PF2, SCLK2, CTS2
11	PG7, TB8OUT	36	PH3, TB1IN1
12	TEST2	37	PB4
13	DVSS	38	PI0, TB0OUT
14	DVCC	39	PJ6, INT6
15	PG4, SO2, SDA2	40	PI1, TB1OUT
16	PG5, SI2, SCL2	41	PB5
17	PG6, SCK2	42	PI2, TB2OUT
18	TEST1	43	PB6
19	PF7, INT5	44	PF4, SO1, SDA1
20	PE0, TXD0	45	PF5, SI1, SCL1
21	PE1, RXD0	46	PF6, SCK1
22	PE2, SCLK0, CTS0	47	PB7
23	PE4, TXD1	48	PI3, TB3OUT
24	PE5, RXD1	49	PJ1, INT1
25	PE6, SCLK1, CTS1	50	PK0, CEC

Pin No.	Pin name	Pin No.	Pin name
51	PK1, SCOUT, \overline{ALARM}	76	REGVCC
52	PI4, TB4OUT	77	XT1
53	PI5, TB5OUT	78	XT2
54	PB0, TDO, SWV	79	PI6, TB4IN0
55	PA0, TMS, SWDIO	80	\overline{NMI}
56	PA1, TCK, SWCLK	81	MODE
57	TEST3	82	\overline{RESET}
58	PJ7, INT7	83	PI7, TB4IN1
59	PB1, TDI	84	PH6, TB3IN0
60	PB2, \overline{TRS}	85	PH7, TB3IN1
61	PF3, RXIN1	86	PJ2, INT2
62	DVCC	87	PJ3, INT3
63	DVSS	88	PJ4, TB6OUT
64	PA2, TRACECLK	89	PE3, RXIN0
65	PA3, TRACEDATA0	90	TEST4
66	PA4, TRACEDATA1	91	PC0, AN0
67	PA5, TRACEDATA2	92	PC1, AN1
68	PA6, TRACEDATA3	93	PC2, AN2
69	PA7	94	PC3, AN3
70	PJ0, INT0	95	PD0, AN4, TB5IN0
71	CVCC	96	PD1, AN5, TB5IN1
72	X2	97	PD2, AN6, TB6IN0
73	CVSS	98	PD3, AN7, TB6IN1
74	X1	99	PD4, AN8
75	REGVSS	100	PD5, AN9

ADV7622BSTZ (HDMI : IC11)

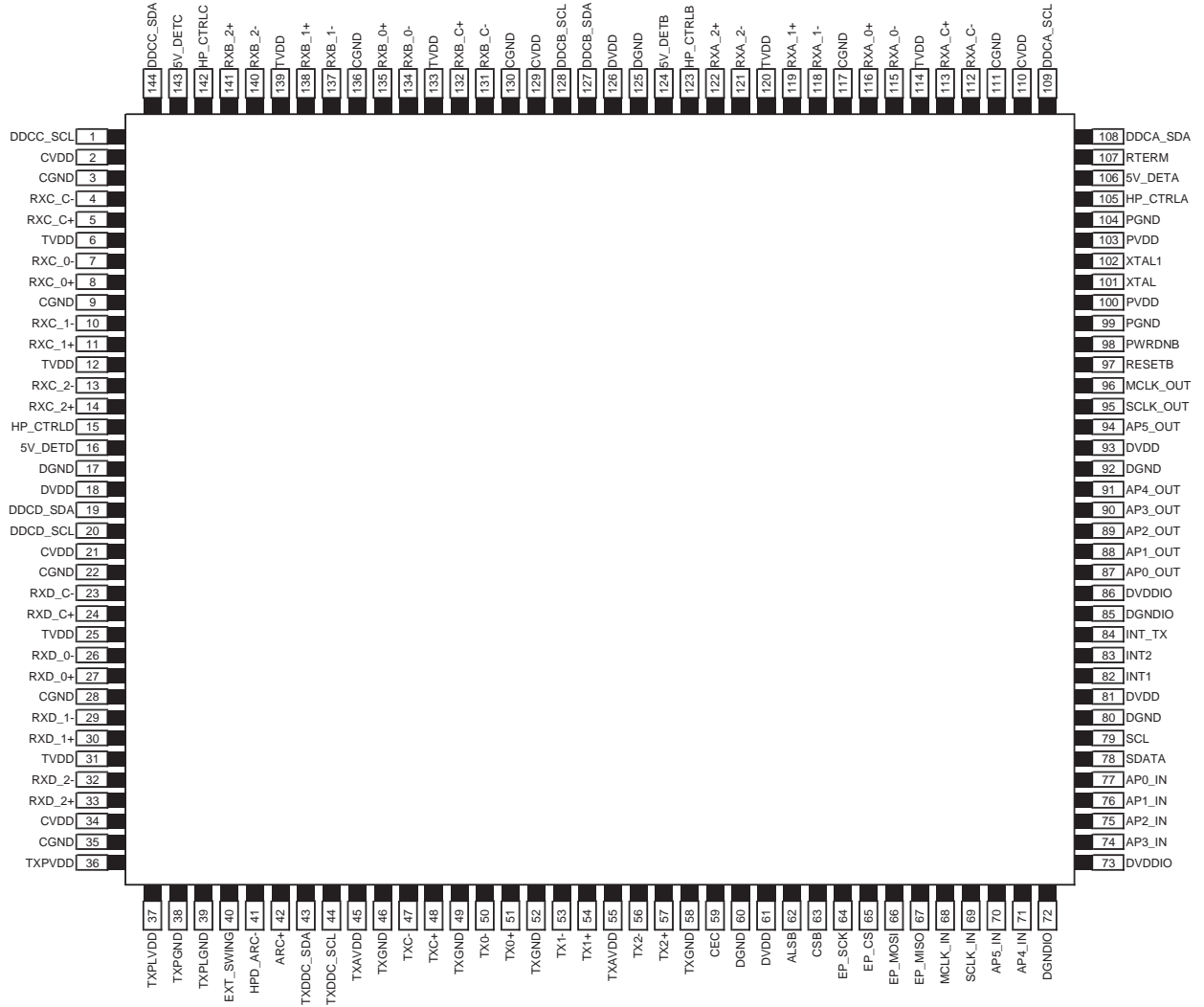

ADV7622BSTZ Terminal Functions

Location	Mnemonic	Type	Description
1	DDCC_SCL	Digital Input	HDCP slave serial clock port C. DDCC_SCL is a 3.3 V input that is 5 V tolerant.
2	CVDD	Power	Receiver comparator supply voltage (1.8V)
3	CGND	Ground	TVDD and CVDD Ground
4	RXC_C-	HDMI Input	Digital input clock Complement of port C in the HDMI interface.
5	RXC_C+	HDMI Input	Digital input clock True of port C in the HDMI interface.
6	TVDD	Power	Receiver terminator supply voltage (3.3 V)
7	RXC_0-	HDMI Input	Digital input channel 0 Complement of port C in the HDMI interface.
8	RXC_0+	HDMI Input	Digital input channel 0 True of port C in the HDMI interface.
9	CGND	Ground	TVDD and CVDD Ground
10	RXC_1-	HDMI Input	Digital input channel 1 Complement of port C in the HDMI interface.
11	RXC_1+	HDMI Input	Digital input channel 1 True of port C in the HDMI interface.
12	TVDD	Power	Receiver terminator supply voltage (3.3 V)
13	RXC_2-	HDMI Input	Digital input channel 2 Complement of port C in the HDMI interface.
14	RXC_2+	HDMI Input	Digital input channel 2 True of port C in the HDMI interface.
15	HP_CTRLD	Digital Output	Hot Plug Detect for Port D.
16	5V_DETD	Digital Input	5 V detect pin for port D in the HDMI interface.
17	DGND	Ground	Ground for DVDD
18	DVDD	Power	Digital supply voltage (1.8 V)
19	DDCD_SDA	Digital I/O	HDCP slave serial data ports D. DDCD_SDA is a 3.3 V input/output that is 5 V tolerant.
20	DDCD_SCL	Digital Input	HDCP slave serial clock port D. DDCD_SCL is a 3.3 V input that is 5 V tolerant.
21	CVDD	Power	Receiver comparator supply voltage (1.8V)
22	CGND	Ground	TVDD and CVDD Ground
23	RXD_C-	HDMI Input	Digital input clock Complement of port D in the HDMI interface.
24	RXD_C+	HDMI Input	Digital input clock True of port D in the HDMI interface.
25	TVDD	Power	Receiver terminator supply voltage (3.3 V)
26	RXD_0-	HDMI Input	Digital input channel 0 Complement of port

Location	Mnemonic	Type	Description
			D in the HDMI interface.
27	RXD_0+	HDMI Input	Digital input channel 0 True of port D in the HDMI interface.
28	CGND	Ground	TVDD and CVDD Ground
29	RXD_1-	HDMI Input	Digital input channel 1 complement of port D in the HDMI interface.
30	RXD_1+	HDMI Input	Digital input channel 1 true of port D in the HDMI interface.
31	TVDD	Power	Receiver terminator supply voltage (3.3 V)
32	RXD_2-	HDMI Input	Digital input channel 2 complement of port D in the HDMI interface.
33	RXD_2+	HDMI Input	Digital input channel 2 true of port D in the HDMI interface.
34	CVDD	Power	Receiver comparator supply voltage (1.8V)
35	CGND	Ground	TVDD and CVDD Ground
36	TXPVDD	Power	1.8 V Power Supply for Digital and I/O Power Supply. These pins supply power to the digital logic and I/Os. They should be filtered and as quiet as possible.
37	TXPLVDD	Power	1.8 V Power Supply.
38	TXGND	Ground	TXPVDD Ground
39	TXPGND	Ground	TXPLVDD Ground
40	EXT_SWING	Analog Input	Sets Internal Reference Currents. Place 887 Ω resistor (1% tolerance) between this pin and ground.
41	HPD_ARC-	Analog Input	Hot Plug Detect Signal. This indicates to the interface whether the receiver is connected. Supports 1.8 V to 5.0V CMOS logic levels.
42	ARC+	Analog Input	Audio return channel input
43	TXDDC_SDA	Digital I/O	Serial Port Data I/O to Receiver. This pin serves as the master to the DDC bus. Supports a 5 V CMOS logic level.
44	TXDDC_SCL	Digital Input	Serial Port Data Clock to Receiver. This pin serves as the master clock for the DDC bus. Supports a 5 V CMOS logic level.
45	TXAVDD	Power	1.8V power supply for TMDS outputs
46	TXGND	Ground	TXAVDD Ground
47	TXC-	HDMI Output	Differential Clock Output. Differential clock output at the TMDS clock rate; supports TMDS logic level.
48	TXC+	Output	Differential Clock Output. Differential clock output at the TMDS clock rate; supports TMDS logic level.

Location	Mnemonic	Type	Description
49	TXGND	Ground	TXAVDD Ground
50	TX0-	HDMI Output	Differential Output Channel 0 Complement. Differential output of the red data at 10× the pixel clock rate; supports TMDS logic level.
51	TX0+	HDMI Output	Differential Output Channel 0 True. Differential output of the red data at 10× the pixel clock rate; supports TMDS logic level.
52	TXGND	Ground	TXAVDD Ground
53	TX1-	HDMI Output	Differential Output Channel 1 Complement. Differential output of the red data at 10× the pixel clock rate; supports TMDS logic level.
54	TX1+	HDMI Output	Differential Output Channel 1 True. Differential output of the red data at 10× the pixel clock rate; supports TMDS logic level.
55	TXAVDD	Power	1.8V power supply for TMDS outputs
56	TX2-	HDMI Output	Differential Output Channel 2 Complement. Differential output of the red data at 10× the pixel clock rate; supports TMDS logic level.
57	TX2+	HDMI Output	Differential Output Channel 2 True. Differential output of the red data at 10× the pixel clock rate; supports TMDS logic level.
58	TXGND	Ground	TXAVDD Ground
59	CEC	Digital I/O	Consumer electronic control channel.
60	DGND	Ground	Ground for DVDD
61	DVDD	Power	Digital supply voltage (1.8 V)
62	ALSB	Digital Input	This pin is used to set I2C address of the Rx IO and the Tx Main Map.
63	CSB	Digital Input	Chip Select pin. This pin must be set low or left floating for the chip to process I2C messages that are destined to the ADV7622. The ADV7622 ignores I2C messages which he receives if this pin is high.
64	EP_SCK	Digital Output	SPI clock interface for the EDID
65	EP_CS	Digital Output	SPI chip selected interface for the EDID
66	EP_MOSI	Digital Output	SPI master out/slave in for the EDID
67	EP_MISO	Digital Input	SPI master in/slave out for the EDID
68	MCLK_IN	Digital Input	Audio Reference Clock. $128 \times N \times fs$ with

Location	Mnemonic	Type	Description
			N = 1, 2, 3, or 4. Set to $128 \times$ sampling frequency (fs), $256 \times$ fs, $384 \times$ fs, or $512 \times$ fs. Supports 1.8 V to 3.3 V CMOS logic levels.
69	SCLK_IN	Digital Input	I2S Audio Clock. Supports CMOS logic levels from 1.8 V to 3.3 V.
70	AP5_IN	Digital Input	Audio Input Port 5. CMOS logic levels from 1.8 V to 3.3 V.
71	AP4_IN	Digital Input	Audio Input Port 4. CMOS logic levels from 1.8 V to 3.3 V.
72	DGNDIO	Ground	Ground for DVDDIO
73	DVDDIO	Power	Digital I/O supply voltage (3.3 V)
74	AP3_IN	Digital Input	Audio Input Port 3. CMOS logic levels from 1.8 V to 3.3 V.
75	AP2_IN	Digital Input	Audio Input Port 2. CMOS logic levels from 1.8 V to 3.3 V.
76	AP1_IN	Digital Input	Audio Input Port 1. CMOS logic levels from 1.8 V to 3.3 V.
77	AP0_IN	Digital Input	Audio Input Port 0. CMOS logic levels from 1.8 V to 3.3 V.
78	SDATA	Digital I/O	I2C port serial data input/output pin. SDA is the data line for the control port.
79	SCL	Digital Input	I2C port serial clock input. SCL is the clock line for the control port.
80	DGND	Ground	Ground for DVDD
81	DVDD	Power	Digital supply voltage (1.8 V)
82	INT1 (AMUTE1)	Digital Output	Interrupt pin, can be active low or active high. When status bits change, this pin is triggered. The events that trigger an interrupt are under user control. This pin can also output an audio mute signal
83	INT2 (AMUTE2)	Digital Output	Interrupt pin, can be active low or active high. When status bits change, this pin is triggered. The events that trigger an interrupt are under user control. This pin can also output an audio mute signal. I2C LSB selection.
84	INT_TX	Digital Output	Interrupt. Open drain. A 2 k Ω pull-up resistor to the microcontroller I/O supply is recommended.
85	DGNDIO	Ground	Ground for DVDDIO
86	DVDDIO	Power	Digital I/O supply voltage (3.3 V)

Location	Mnemonic	Type	Description
87	AP0_OUT	Digital Output	Audio output port 0.
88	AP1_OUT	Digital Output	Audio output port 1.
89	AP2_OUT	Digital Output	Audio output port 2.
90	AP3_OUT	Digital Output	Audio output port 3.
91	AP4_OUT	Digital Output	Audio output port 4.
92	DGND	Ground	Ground for DVDD
93	DVDD	Power	Digital supply voltage (1.8 V)
94	AP5_OUT	Digital Output	Audio output port 5.
95	SCLK_OUT	Digital Output	Audio serial clock output.
96	MCLK_OUT	Digital Output	Audio master clock output.
97	RESETB	Digital Input	System reset input. Active low. A minimum low reset pulse width of 5 ms is required to reset the ADV7622 circuitry.
98	PWRDNB	Digital Input	Active low power-down pin. This pin should be used as a system detect when the internal EDID is powered from the 5V signal from the HDMI port when connected to active equipment. Pin pulled down internally.
99	PGND	Ground	Ground for PVDD
100	PVDD	Power	PLL supply voltage
101	XTAL	Miscellaneous Analog	Input pin for 28.63636 MHz crystal or an external 1.8 V 28.63636 MHz clock oscillator source to clock the ADV7622. The following crystal frequencies are also supported: 24.576 MHz and 27 MHz.
102	XTAL1	Miscellaneous Analog	Crystal output pin. This pin should be left floating if a clock oscillator is used.
103	PVDD	Power	PLL supply voltage
104	PGND	Ground	PVDD Ground
105	HP_CTRLA	Digital Output	Hot Plug Detect for port A.
106	5V_DETA	Digital Input	5 V detect pin for port A in the HDMI interface.
107	RTERM	Miscellaneous Analog	Sets internal termination resistance. A 500 Ω resistor between this pin and GND should be used.
108	DDCA_SDA	Digital I/O	HDCP slave serial data port A. DDCA_SDA is a 3.3 V input/output that is 5 V tolerant.
109	DDCA_SCL	Digital Input	HDCP slave serial clock port A. DDCA_SCL is a 3.3 V input that is 5 V tolerant.
110	CVDD	Power	Receiver comparator supply voltage (1.8V)
111	CGND	Ground	TVDD and CVDD Ground

Location	Mnemonic	Type	Description
112	RXA_C-	HDMI Input	Digital input clock Complement of port A in the HDMI interface.
113	RXA_C+	HDMI Input	Digital input clock True of port A in the HDMI interface.
114	TVDD	Power	Receiver terminator supply voltage (3.3 V)
115	RXA_0-	HDMI Input	Digital input channel 0 complement of port A in the HDMI interface.
116	RXA_0+	HDMI Input	Digital input channel 0 true of port A in the HDMI interface.
117	CGND	Ground	TVDD and CVDD Ground
118	RXA_1-	HDMI Input	Digital input channel 1 complement of port A in the HDMI interface.
119	RXA_1+	HDMI Input	Digital input channel 1 true of port A in the HDMI interface.
120	TVDD	Power	Receiver terminator supply voltage (3.3 V)
121	RXA_2-	HDMI Input	Digital input channel 2 complement of port A in the HDMI interface.
122	RXA_2+	HDMI Input	Digital input channel 2 true of port A in the HDMI interface.
123	HP_CTRLB	Digital Output	Hot Plug Detect for port B.
124	5V_DET B	Digital Input	5 V detect pin for port B in the HDMI interface.
125	DGND	Ground	Ground for DVDD
126	DVDD	Power	Digital supply voltage (1.8 V)
127	DDCB_SDA	Digital I/O	HDCP slave serial data ports B. DDCB_SDA is a 3.3 V input/output that is 5 V tolerant.
128	DDCB_SCL	Digital Input	HDCP slave serial clock port B. DDCB_SCL is a 3.3 V input that is 5 V tolerant.
129	CVDD	Power	Receiver comparator supply voltage (1.8V)
130	CGND	Ground	TVDD and CVDD Ground
131	RXB_C-	HDMI Input	Digital input clock complement of port B in the HDMI interface.
132	RXB_C+	HDMI Input	Digital input clock true of port B in the HDMI interface.
133	TVDD	Power	Receiver terminator supply voltage (3.3 V)
134	RXB_0-	HDMI Input	Digital input channel 0 complement of port B in the HDMI interface.
135	RXB_0+	HDMI Input	Digital input channel 0 true of port B in the HDMI interface.
136	CGND	Ground	TVDD and CVDD Ground
137	RXB_1-	HDMI Input	Digital input channel 1 complement of port B in the HDMI interface.

Location	Mnemonic	Type	Description
138	RXB_1+	HDMI Input	Digital input channel 1 true of port B in the HDMI interface.
139	TVDD	Power	Receiver terminator supply voltage (3.3 V)
140	RXB_2-	HDMI Input	Digital input channel 2 complement of port B in the HDMI interface.
141	RXB_2+	HDMI Input	Digital input channel 2 true of port B in the HDMI interface.
142	HP_CTRL_C	Digital Output	Hot Plug Detect for port C.
143	5V_DETC	Digital Input	5 V detect pin for port C in the HDMI interface.
144	DDCC_SDA	Digital I/O	HDCP slave serial clock port C. DDCC_SDA is a 3.3 V input/output that is 5 V tolerant.

EX3AV (HDMI : IC16)

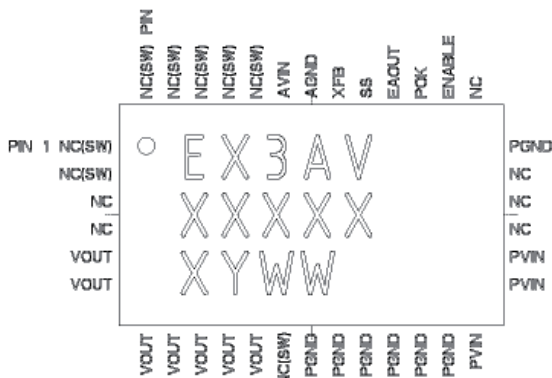

EX3AV Terminal Functions

PIN	NAME	FUNCTION
1-2, 12, 26, 34-38	NC(SW)	NO CONNECT – These pins are internally connected to the common switching node of the internal MOSFETs. They are not to be electrically connected to any external signal, ground, or voltage. Failure to follow this guideline may result in damage to the device.
3-4, 22-25	NC	NO CONNECT – These pins may be internally connected. Do not connect them to each other or to any other electrical signal. Failure to follow this guideline may result in device damage.
5-11	VOUT	Regulated converter output. Connect these pins to the load, and place output capacitor from these pins and PGND pins 13-15
13-18	PGND	Input/Output power ground. Connect these pins to the ground electrode of the Input and output filter capacitors. See VOUT and PVIN pin descriptions for more details.
19-21	PVIN	Input power supply. Connect to input power supply. Decouple with input capacitor to PGND pins 16-18.
27	ENABLE	Input Enable. Applying logic high enables the output and initiates a soft-start. Applying a logic low disables the output.
28	POK	Power OK is an open drain transistor for power system state indication. POK will be logic high when VOUT is with -10% to +20% of VOUT nominal.
29	EAOUT	Optional Error Amplifier output. Allows for customization of the control loop response.
30	SS	Soft-Start node. The soft-start capacitor is connected between this pin and AGND. The value of this capacitor determines the startup time.
31	XFB	External Feedback Input. The feedback loop is closed through this pin. A voltage divider at VOUT is used to set the output voltage. The mid point of the divider is connected to XFB. A phase lead capacitor from this pin to VOUT is also required to stabilize the loop.
32	AGND	Analog Ground. This is the Ground return for the controller. Needs to be connected to a quiet ground.
33	AVIN	Input power supply for the controller. Needs to be connected to input voltage at a quiet point.

2. FL DISPLAY

FLD (18-ST-13GINK) (FRONT : U100)

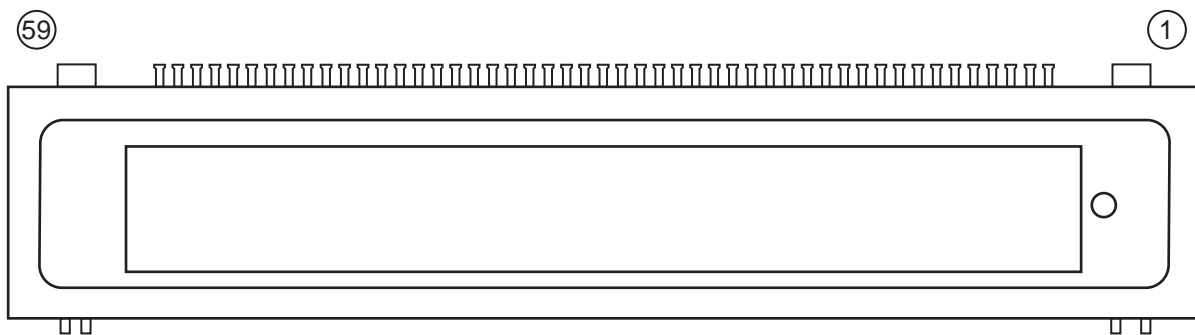

PIN CONNECTION

PIN NO.	59	58	57	56	55	54	53	52	51	50	49	48	47	46	45	44	43~10	9	8	7	6	5	4	3	2	1
CONNECTION	NX	F2	NP	NP	NP	L-GND	D-GND	DISP	VDD	OSCO	RST	CS	CP	DA	DO	TEST	NX	18G	17G	Q17	Q18	NP	NP	NP	F1	NX

◎ Note ◎

- 1) Fn : Filament pin
- 2) NP : No pin
- 3) NX : No extended pin
- 4) nG : Grid pin

GRID ASSIGNMENT

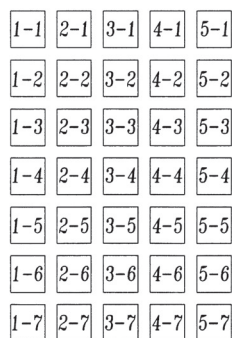
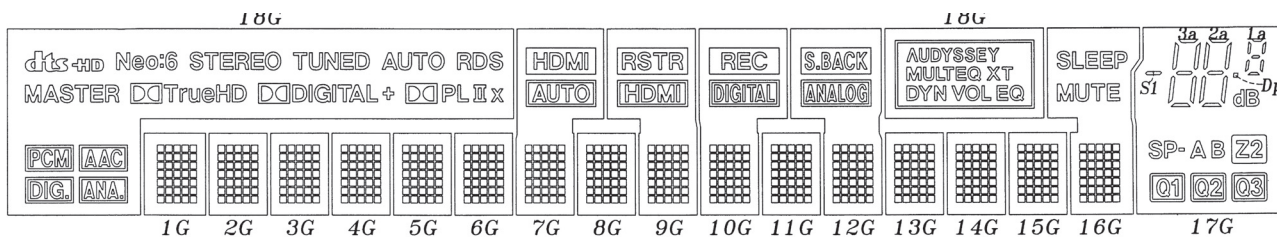

(1G~16G)

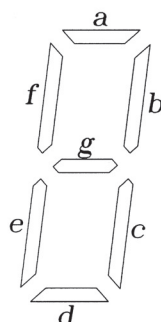

(17G)

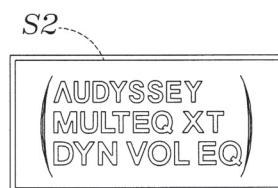

(18G)

ANODE CONNECTION

	COM1	COM2	COM3	COM4	COM5	COM6	COM7	COM8	COM9	COM10	COM11	COM12	COM13	COM14	COM15	COM16	COM17	COM18
	1G	2G	3G	4G	5G	6G	7G	8G	9G	10G	11G	12G	13G	14G	15G	16G	17G	18G
SEGA 1	1-1	1-1	1-1	1-1	1-1	1-1	1-1	1-1	1-1	1-1	1-1	1-1	1-1	1-1	1-1	1-1	S1	S2
SEGA 2	2-1	2-1	2-1	2-1	2-1	2-1	2-1	2-1	2-1	2-1	2-1	2-1	2-1	2-1	2-1	2-1	3d	EQ
SEGA 3	3-1	3-1	3-1	3-1	3-1	3-1	3-1	3-1	3-1	3-1	3-1	3-1	3-1	3-1	3-1	3-1	2d	VOL
SEGA 4	4-1	4-1	4-1	4-1	4-1	4-1	4-1	4-1	4-1	4-1	4-1	4-1	4-1	4-1	4-1	4-1	3e	DYN
SEGA 5	5-1	5-1	5-1	5-1	5-1	5-1	5-1	5-1	5-1	5-1	5-1	5-1	5-1	5-1	5-1	5-1	2e	XT
SEGA 6	1-2	1-2	1-2	1-2	1-2	1-2	1-2	1-2	1-2	1-2	1-2	1-2	1-2	1-2	1-2	1-2	3c	HAUTSBO
SEGA 7	2-2	2-2	2-2	2-2	2-2	2-2	2-2	2-2	2-2	2-2	2-2	2-2	2-2	2-2	2-2	2-2	2c	AUDITSEY
SEGA 8	3-2	3-2	3-2	3-2	3-2	3-2	3-2	3-2	3-2	3-2	3-2	3-2	3-2	3-2	3-2	3-2	3g	X
SEGA 9	4-2	4-2	4-2	4-2	4-2	4-2	4-2	4-2	4-2	4-2	4-2	4-2	4-2	4-2	4-2	4-2	2g	I
SEGA 10	5-2	5-2	5-2	5-2	5-2	5-2	5-2	5-2	5-2	5-2	5-2	5-2	5-2	5-2	5-2	5-2	3f	PL
SEGA 11	1-3	1-3	1-3	1-3	1-3	1-3	1-3	1-3	1-3	1-3	1-3	1-3	1-3	1-3	1-3	1-3	2f	DCI (PL)
SEGA 12	2-3	2-3	2-3	2-3	2-3	2-3	2-3	2-3	2-3	2-3	2-3	2-3	2-3	2-3	2-3	2-3	3b	+
SEGA 13	3-3	3-3	3-3	3-3	3-3	3-3	3-3	3-3	3-3	3-3	3-3	3-3	3-3	3-3	3-3	3-3	2b	MASTER
SEGA 14	4-3	4-3	4-3	4-3	4-3	4-3	4-3	4-3	4-3	4-3	4-3	4-3	4-3	4-3	4-3	4-3	3a	PCM
SEGA 15	5-3	5-3	5-3	5-3	5-3	5-3	5-3	5-3	5-3	5-3	5-3	5-3	5-3	5-3	5-3	5-3	2a	AMC
SEGA 16	1-4	1-4	1-4	1-4	1-4	1-4	1-4	1-4	1-4	1-4	1-4	1-4	1-4	1-4	1-4	1-4	Dp	DCI
SEGA 17	2-4	2-4	2-4	2-4	2-4	2-4	2-4	2-4	2-4	2-4	2-4	2-4	2-4	2-4	2-4	2-4	dB	AMA
SEGA 18	3-4	3-4	3-4	3-4	3-4	3-4	3-4	3-4	3-4	3-4	3-4	3-4	3-4	3-4	3-4	3-4	1d	POS
SEGA 19	4-4	4-4	4-4	4-4	4-4	4-4	4-4	4-4	4-4	4-4	4-4	4-4	4-4	4-4	4-4	4-4	1e	AUTO
SEGA 20	5-4	5-4	5-4	5-4	5-4	5-4	5-4	5-4	5-4	5-4	5-4	5-4	5-4	5-4	5-4	5-4	1c	TUNED
SEGA 21	1-5	1-5	1-5	1-5	1-5	1-5	1-5	1-5	1-5	1-5	1-5	1-5	1-5	1-5	1-5	1-5	1g	STEREO
SEGA 22	2-5	2-5	2-5	2-5	2-5	2-5	2-5	2-5	2-5	2-5	2-5	2-5	2-5	2-5	2-5	2-5	1f	Neoc6
SEGA 23	3-5	3-5	3-5	3-5	3-5	3-5	3-5	3-5	3-5	3-5	3-5	3-5	3-5	3-5	3-5	3-5	1b	400
SEGA 24	4-5	4-5	4-5	4-5	4-5	4-5	4-5	4-5	4-5	4-5	4-5	4-5	4-5	4-5	4-5	4-5	1a	d1x
SEGA 25	5-5	5-5	5-5	5-5	5-5	5-5	5-5	5-5	5-5	5-5	5-5	5-5	5-5	5-5	5-5	5-5	SP-	
SEGA 26	1-6	1-6	1-6	1-6	1-6	1-6	1-6	1-6	1-6	1-6	1-6	1-6	1-6	1-6	1-6	1-6	A	
SEGA 27	2-6	2-6	2-6	2-6	2-6	2-6	2-6	2-6	2-6	2-6	2-6	2-6	2-6	2-6	2-6	2-6	B	
SEGA 28	3-6	3-6	3-6	3-6	3-6	3-6	3-6	3-6	3-6	3-6	3-6	3-6	3-6	3-6	3-6	3-6	Z2	
SEGA 29	4-6	4-6	4-6	4-6	4-6	4-6	4-6	4-6	4-6	4-6	4-6	4-6	4-6	4-6	4-6	4-6	O1	
SEGA 30	5-6	5-6	5-6	5-6	5-6	5-6	5-6	5-6	5-6	5-6	5-6	5-6	5-6	5-6	5-6	5-6	O2	
SEGA 31	1-7	1-7	1-7	1-7	1-7	1-7	1-7	1-7	1-7	1-7	1-7	1-7	1-7	1-7	1-7	1-7	O3	
SEGA 32	2-7	2-7	2-7	2-7	2-7	2-7	2-7	2-7	2-7	2-7	2-7	2-7	2-7	2-7	2-7	2-7		
SEGA 33	3-7	3-7	3-7	3-7	3-7	3-7	3-7	3-7	3-7	3-7	3-7	3-7	3-7	3-7	3-7	3-7		
SEGA 34	4-7	4-7	4-7	4-7	4-7	4-7	4-7	4-7	4-7	4-7	4-7	4-7	4-7	4-7	4-7	4-7		
SEGA 35	5-7	5-7	5-7	5-7	5-7	5-7	5-7	5-7	5-7	5-7	5-7	5-7	5-7	5-7	5-7	5-7	MUTE	SLEEP
ADA							AUTO	REC	REC	REC	REC	REC	REC	REC	REC	REC	REC	REC
A8B							REC	REC	REC	REC	REC	REC	REC	REC	REC	REC	REC	REC

PARTS LIST OF P.W.B. UNIT

* Parts for which "nsp" is indicated on this table cannot be supplied.

* Part indicated with the mark "★" is not illustrated in the exploded view.

* The parts listed below are for maintenance only, might differ from the parts used in the unit in appearances or dimensions.

Note: The symbols in the column "Remarks" indicate the following destinations.

1311E2 : Europe model

1311E1C : China model

391E3 : U.S.A. & Canada model

391E3B : Brazil model ▲

391EA : Australia model

BK : Black model

SP : Premium Silver model

FRONT P.W.B. UNIT ASS'Y

Ref. No.	Part No.	Part Name	Remarks	Q'ty	New
SEMICONDUCTORS GROUP					
	IC202,203	943239005300M	IC BA4560RF		HVIBA4560RF
	Q201	943219006820S	TR KTC1027Y		CVTKTC1027YT
	Q202	00MHT600141B1	TR KTA1271Y		HVTKTA1271YT
	Q203	00D2690192902	TR KRC102S		HVTKRC102S
	Q205,206	00D2690184907	CHIP TR KRA102S		HVTKRA102S
	Q207,208	00D2690192902	TR KRC102S		HVTKRC102S
	Q209	00D2690184907	CHIP TR KRA102S		HVTKRA102S
	Q211	00D2690192902	TR KRC102S		HVTKRC102S
	Q213,214	00D2730464901	CHIP TR KTC3875SYRTK		HVTKTC3875SYRTK
	D201	943202010030S	DIODE ZJ18BT		CVDZJ18BT
	D206	nsp	COPPER WIRE		C3A206
	D207	nsp	COPPER WIRE		C3A206
	D208	943202010040S	DIODE ZJ22BT		CVDZJ22BT
	D213	943203003170S	DIODE GBJ606		HVDGBJ606
	D214	90M-HD302360R	DIODE ZJ6.8BT		CVDZJ6.8BT
	D215	943176010090S	LED BLBJEGJ204L		CVDBLBJEGJ204L
	D216-221	943203003150S	DIODE 1N4007T		HVD1N4007T
	D222	nsp	COPPER WIRE		C3A206
	D224,225	943201010100S	DIODE 1SS133MT		CVD1SS133MT
	D226-233	943209001080S	DIODE 1SS355T		CVD1SS355T
RESISTORS GROUP					
	R215	nsp	METAL RES(OXIDE)FILM,5%		KRG1SANJ4R7RT
	R249	nsp	CHIP RES1%75OHM		CRJ10DF75R0T
	R262,263	nsp	METAL RES OXIDEFILM2W		KRG2SANJ471RT
	R268,269	nsp	METAL RES FILM1W5%		CRG1SANJR22RTP
	R275,276	nsp	METAL RES FILM1W5%		CRG1SANJR22RTP
	R283-286	nsp	METAL RES FILM1W5%		CRG1SANJR22RTP
	VR201	943671010330S	ENCODER VR		CSR2A055Z
CAPACITORS GROUP					
	C201,202	nsp	CHIP CAP 330PF 50V J		CCU1H331JA
	C203	943134010530S	ELECT CAP 1UF 50V C		CCEA1HH1R0T
	C205	943134010690S	ELECT CAP		CCEA1JH471E
	C206	943134010540S	ELECT CAP 2.2UF 50 V		CCEA1HH2R2T
	C207	943134010530S	ELECT CAP 1UF 50V		CCEA1HH1R0T
	C210	943134010520S	ELECT CAP 10UF 50V		CCEA1HH100T

	Ref. No.	Part No.	Part Name	Remarks		Q'ty	New
	C211	nsp	CHIP CAP 0.1UF 50V K		CCUS1H104KC		
	C213	nsp	MYLAR CAP 0.1UF 50V J		HCQ1H104JZT		
	C214,215	943134010520S	ELECT CAP 10UF 50V		CCEA1HH100T		
	C216	943134010530S	ELECT CAP 1UF 50V		CCEA1HH1R0T		
	C217	943134010670S	ELECT CAP 47UF 16V		CCEA1CKS470T		
	C218,219	943134010520S	ELECT CAP 10UF 50V		CCEA1HH100T		
	C223,224	nsp	METALLIZEDFILM CAP		CCME2A473JXT		
	C226-228	nsp	CHIP CAP 0.1UF 50V K		CCUS1H104KC		
	C229-231	nsp	CHIP CAP 100PF 50V J		CCUS1H101JA		
	C233-235	nsp	CHIP CAP 0.01UF 50V K		CCUS1H103KC		
	C241,242	nsp	CHIP CAP 100PF 50V J		CCUS1H101JA		
	C244	nsp	METALLIZED CAP 0.1UF 250V J		KCME2E104JP04T		
	C245	nsp	CHIP CAP 0.1UF 50V K		CCUS1H104KC		
	C246,247	nsp	METALLIZED CAP 0.1UF 250V J		KCME2E104JP04T		
	C248-250	nsp	METALLIZED FILM CAP		CCME2A473JXT		
	C251	943134010530S	ELECT CAP 1UF 50V		CCEA1HH1R0T		
	C254	nsp	CHIP CAP 1000PF 50VK		CCUS1H102KC		
	C255-257	nsp	METALLIZED FILM CAP		CCME2A473JXT		
	C258,259	nsp	CHIP CAP 0.1UF 50V K		CCUS1H104KC		
	C261	943134010530S	ELECT CAP 1UF 50V		CCEA1HH1R0T		
	C262	nsp	CHIP CAP 39PF50V J		CCUS1H390JA		
	C263	nsp	CHIP CAP 0.1UF 100V		CCUC2A104KC		
	C264	943134010530S	ELECT CAP 1UF 50V		CCEA1HH1R0T		
	C265,266	nsp	CHIP CAP 330PF 50V J		CCUS1H331JA		
	C267,268	943134010520S	ELECT CAP 10UF 50V		CCEA1HH100T		
	C269,270	nsp	CHIP CAP 0.1UF 50VK		CCUS1H104KC		
	C271-274	943134010520S	ELECT CAP 10UF 50V		CCEA1HH100T		
	C277	nsp	MYLAR CAP 0.1UF 50V J		HCQ1H104JZT		
	C278,279	943134010520S	ELECT CAP 10UF 50V		CCEA1HH100T		
	C280-299	nsp	CHIP CAP 0.1UF50VK		CCUS1H104KC		
	C208	nsp	CHIP CAP 0.1UF50VK		CCUS1H104KC		
	C212	nsp	CHIP CAP 0.1UF50VK		CCUS1H104KC		
	C209	943134010700S	CAP,ELECT		CCEA1HH3R3T		
OTHERS PARTS GROUP							
	BK201,202	nsp	FIP BRACKET		CMD1A572		
	BN204	nsp	WIRE ASSY		CWB1B00510047		
	BN205	nsp	WIRE ASSY		CWB1B003050NN		
	BN207	nsp	WIRE ASSY		CWB4B00508047		
	BN208	nsp	WIRE ASSY		CWB4B005080E7		
	BN209	nsp	WIRE ASSY		CWB4B00330047		
	BN21A	nsp	WIRE ASSY		CWB1B00505077		
	BN45	nsp	WIRE ASSY(LOCK 3P 120MM 2.5MM)		CWB1D00312058		
	BN46	nsp	WIRE ASSY		CWB4D00725058		
	LUG23	nsp	WIRE ASSY		CWE8102100RV		
	CN1B	nsp	WAFER		CJP23GB116ZY		
	CN41	nsp	WAFER		CJP03KA060ZY		
	CN44	nsp	LOCKINGTYPE STRAIGHTWAFER 2MM		CJP03GI236ZW		
	CN201	nsp	WAFER STRAIGHT(7PIN)		CJP07GA01ZY		
	CN203	nsp	WAFER(3.96MM)		CJP03GA148ZW		
	CN204	nsp	WAFER(5PLOCKANGLE2.0MM)		CJP05GJ247ZW		

	Ref. No.	Part No.	Part Name	Remarks		Q'ty	New
	CN207	nsp	LOCKINGTYPE STRAIGHTWAFER 2mm		CJP05GI236ZW		
	CN208	nsp	WAFER STRAIGHT		CJP05GA19ZY		
	CN209	nsp	WAFER ANGLE(2.5mm)		CJP05GB03ZY		
	△ F201	943652000620S	FUSE(0.1A 372SERIES/TR5)		CBA2D0100A3EYT		
	FL201	943172010110S	VFD HCA-18SM01T		CFLHCA18SM01T		*
	GND21,22	nsp	PCB BRACKET		CMD1A569		
	JK201	90M-YT004310R	JACK BOARD(3P)		CJJ4S041Z		
	JK202	943643010130S	JACK		CJJ2E020Z		*
	JK204	943643010140S	JACK HEADPHONE(3.5mm GOLD)		CJJ2E028Z		*
	L201-206	nsp	CHIP FERRITE BEAD(60ohm 1608)		CLZ9R005Z		
	LUG21	nsp	WIRE ASS'Y(1P)		CWE8102080RV		
	LUG22	nsp	WIRE ASS'Y		CWE8202100RV		
	LUG24	nsp	WIRE ASS'Y		CWE8102100RV		
	LUG25	nsp	WIRE ASS'Y		CWE8102150RV		
	LUG26	nsp	WIRE ASS'Y(1P)		CWE8202080RV		
	RC201	943262010290S	REMOCON SENSOR		CRVKSM603TH5B		
	SW201-218	00D9430004402	TACT SW		CST1A012ZT		

MAIN P.W.B. UNIT ASS'Y

Ref. No.	Part No.	Part Name	Remarks	Q'ty	New
SEMICONDUCTORS GROUP					
IC41	00D2630641002	REGULATOR IC NJM7912FA		HVINJM7912FA	
IC42	00D2630801004	REGULATOR IC NJM7812FA		HVINJM7812FA	
IC45	00D2631162014	REGULATOR IC KIA78R05PI		HVIKIA78R05PI	
IC46	231010031706S	REGULATOR IC KIA278R05PI		HVIKIA278R05PI	
Q401	00MHT800931A0	TR KTC3200GR		HVTKTC3200GRT	△
Q402,403	00D9430154200	TR KRA102M		HVTKRA102MT	
Q408	00MHT800931A0	TR KTC3200GR		HVTKTC3200GRT	△
Q410-414	00MHT800931A0	TR KTC3200GR		HVTKTC3200GRT	△
Q415	00D2710301903	TR KTA1268BLATP		CVTKTA1268BLATPA	
Q416	00MHT800931A0	TR KTC3200GR		HVTKTC3200GRT	△
Q417-420	00D9430004305	TR KRC107M		HVTKRC107MT	
Q421,423	00D2710301903	TR KTA1268BLATP		CVTKTA1268BLATPA	
Q424	00MHT800931A0	TR KTC3200GR		HVTKTC3200GRT	△
Q425-428	00D2710301903	TR KTA1268BLATP		CVTKTA1268BLATPA	
Q429-436	00MHT800931A0	TR KTC3200GR		HVTKTC3200GRT	△
Q437-444	00D2710301903	TR KTA1268BLATP		CVTKTA1268BLATPA	
Q445	00MHT800931A0	TR KTC3200GR		HVTKTC3200GRT	△
Q448-453	943219010280S	TR KTC2874B		HVTKTC2874BT	
Q454	00MHT327851H0	TR KSC2785Y		HVTKSC2785YT	
Q455	00D9430004305	TR KRC107M		HVTKRC107MT	
Q456	00MHT327851H0	TR KSC2785Y		HVTKSC2785YT	
Q457,458	00D2710301903	TR KTA1268BLATP		CVTKTA1268BLATPA	
Q459,460	00MHT800931A0	TR KTC3200GR		HVTKTC3200GRT	△
Q461-463	90M-HT800120R	TR KTC3114A		HVTKTC3114A	
Q464	90M-HT400490R	POWER TR 2SD2390		HVT2SD2390	
Q465	90M-HT800120R	TR KTC3114A		HVTKTC3114A	
Q466	90M-HT200440R	POWER TR HVT2SB1560		HVT2SB1560	
Q467	90M-HT400490R	POWER TR 2SD2390		HVT2SD2390	
Q468	90M-HT200440R	POWER TR HVT2SB1560		HVT2SB1560	
Q469	90M-HT400490R	POWER TR 2SD2390		HVT2SD2390	
Q470	90M-HT200440R	POWER TR HVT2SB1560		HVT2SB1560	
Q471	90M-HT400490R	POWER TR 2SD2390		HVT2SD2390	
Q472	90M-HT200440R	POWER TR HVT2SB1560		HVT2SB1560	
Q473	90M-HT400490R	POWER TR 2SD2390		HVT2SD2390	
Q474	90M-HT200440R	POWER TR HVT2SB1560		HVT2SB1560	
Q475	90M-HT800120R	TR KTC3114A		HVTKTC3114A	
D401	943202010050S	DIODE ZJ2.4B		CVDZJ2.4BT	
D402	943201010100S	DIODE 1SS133M		CVD1SS133MT	
D404	943201010100S	DIODE 1SS133M		CVD1SS133MT	
D409-437	943201010100S	DIODE 1SS133M		CVD1SS133MT	
D438,439	943203003150S	DIODE 1N4007		HVD1N4007T	
D445,446	943204010120S	SCHOTTKY DIODE 1N5819		HVD1N5819T	
D448	943201010100S	DIODE 1SS133M		CVD1SS133MT	
D449-454	943203003150S	DIODE 1N4007		HVD1N4007T	
D455	nsp	COPPER WIRE		C3A206	
D458-460	943201010100S	DIODE 1SS133M		CVD1SS133MT	
D461	943203003170S	DIODE GBJ606		HVDGBJ606	
D501	nsp	COPPER WIRE		C3A206	

Ref. No.	Part No.	Part Name	Remarks	Q'ty	New
ZD41	943202010070S	DIODE ZJ12B			
ZD48	943202010080S	DIODE ZJ5.1B			
ZD49	90M-HD302440R	DIODE ZJ4.7B			
ZD51-60	90M-HD302390R	DIODE ZJ3.3B			
RESISTORS GROUP					
R494-501	nsp	METAL OXIDE FILM RES(4.7KOHM 5% 1W)			
R502	nsp	METAL OXID EFILM RES(120OHM 1W J)			
R505-514	nsp	METAL OXIDE FILMRES 2W			
R515	nsp	METAL OXIDEFILM RES(10OHM 1W J)			
R516-520	nsp	METAL OXIDE FILMRES 2W			
R527-531	nsp	METAL OXIDEFILM RES(10OHM 1W J)			
R532	nsp	METAL OXIDE FILMRES 2W			
R533-537	nsp	METAL OXID EFILM RES(2.2KOHM 1W J)			
R538	nsp	METAL OXIDEFILM RES(10OHM 1W J)			
R539-542	nsp	METAL OXID EFILM RES(1.2KOHM 1W)			
R543-546	nsp	METAL OXID EFILM RES(47OHM 1W J)			
R547-554	nsp	METAL OXID EFILM RES			
R559	nsp	METAL OXID EFILM RES(2.2KOHM 1W J)			
R563	nsp	METAL OXIDE FILM RES(4.7KOHM 5% 1W)			
R564	nsp	METAL OXIDE FILM RES(100KOHM 5% 1W)			
R577	nsp	METAL OXIDEFILM RES(10OHM 1W J)			
R616	nsp	METAL OXID EFILM RES(1.2KOHM 1W)			
R618	nsp	METAL OXID EFILM RES(47OHM 1W J)			
R619	nsp	METAL OXIDEFILM RES(10OHM 1W J)			
R621	nsp	METAL OXIDEFILM RES(10OHM 1W J)			
R625-628	nsp	METAL OXIDE FILMRES 2W			
	nsp	METAL OXID EFILM RES			
R632	nsp	METAL OXID EFILM RES			
R634,635	nsp	METAL OXIDE FILM RES(4.7KOHM 5% 1W)			
VR41-45	nsp	SEMI FIXED RES(1K BCURVE)			
CAPACITORS GROUP					
C403	943134010660S	ELECT CAP 470UF 6.3V			
C404-407	nsp	MYLAR CAP 2200PF 100V J			
C408	943134010680S	ELECT CAP 47UF 50V			
C409	nsp	SEMICONDUCTOR CAP 0.1UF 50V ZF			
C410	nsp	CERAMIC CAP 470PF 50V KB			
C411,412	nsp	CERAMIC CAP 100PF 50V KB			
C413	nsp	CERAMIC CAP 470PF 50V KB			
C414	nsp	CERAMIC CAP 100PF 50V KB			
C415	nsp	CERAMIC CAP 470PF 50V KB			
C416-418	nsp	SEMICONDUCTOR CAP 0.1UF 50V ZF			
C419,420	nsp	MYLAR CAP 0.01UF 100V J	1311E2		
C419,420	nsp	MYLAR CAP 1000PF 100V J MYLAR	1311E1C,391E3, 391E3B,391EA		
C421	nsp	CERAMIC CAP 470PF 50V KB			
C422	nsp	CERAMIC CAP 100PF 50V KB			

Ref. No.	Part No.	Part Name	Remarks	Q'ty	New
C423-426	nsp	CERAMIC CAP 33PF 50V J		CCCT1H330JC	
C427	943134010660S	ELECT CAP 470UF 6.3V		CCEA0JH471T	
C428	943134010490S	ELECT CAP 100UF 10V		CCEA1AH101T	
C429-431	nsp	MYLAR CAP 0.01UF 100V J	1311E2	HCQ11H103JZT	
C429-431	nsp	MYLAR CAP 1000PF 100V J MYLAR	1311E1C,391E3, 391E3B,391EA	HCQ11H102JZT	△
C432	nsp	MYLAR CAP 0.047UF 50V		HCQ11H473JZT	
C433	nsp	MYLAR CAP 0.047UF 50V	1311E2	HCQ11H473JZT	
C433	nsp	MYLAR CAP 2200PF 100V J	1311E1C,391E3, 391E3B,391EA	HCQ11H222JZT	△
C434-435	nsp	MYLAR CAP 0.047UF 50V		HCQ11H473JZT	
C436-438	nsp	MYLAR CAP 0.047UF 50V	1311E2	HCQ11H473JZT	
C436-438	nsp	MYLAR CAP 2200PF 100V J	1311E1C,391E3, 391E3B,391EA	HCQ11H222JZT	△
C439	nsp	MYLAR CAP 0.047UF 50V		HCQ11H473JZT	
C440	nsp	MYLAR CAP 0.047UF 50V	1311E2	HCQ11H473JZT	
C440	nsp	MYLAR CAP 2200PF 100V J	1311E1C,391E3, 391E3B,391EA	HCQ11H222JZT	△
C441,442	943134010520S	ELECT CAP 10UF 50V		CCEA1HH100T	
C443-445	943134010490S	ELECT CAP 100UF 10V		CCEA1AH101T	
C446-449	943134010680S	ELECT CAP 47UF 50V		CCEA1HH470T	
C450-456	943134010520S	ELECT CAP 10UF 50V		CCEA1HH100T	
C457	943134010480S	ELECT CAP 100UF 100V		CCEA2AH101E	
C458,459	nsp	CERAMIC CAP 0.01UF 50V ZF		CCFT1H103ZF	
C460,461	943134010610S	ELECT CAP 4.7UF 50V		CCEA1HH4R7T	
C462	943134010580S	ELECT CAP 220UF 35V		CCEA1VH221T	
C463	943134010520S	ELECT CAP 10UF 50V		CCEA1HH100T	
C464	nsp	SEMICONDUCTOR CAP 0.1UF 50V ZF		CCFT1H104ZF	
C465	nsp	CERAMIC CAP 330PF 50V KB		CCKT1H331KB	
C466	nsp	SEMICONDUCTOR CAP 0.1UF 50V ZF		CCFT1H104ZF	
C467,468	nsp	CERAMIC CAP 330PF 50V KB		CCKT1H331KB	
C469-471	943134010590S	ELECT CAP 22UF 50V		CCEA1HH220T	
C472	nsp	CERAMIC CAP (400V Y-CAP)		CCKDHS222ME	
C474	943134010640S	ELECT CAP470UF 16V		CCEA1CH471T	
C475,476	943134010460S	ELECT CAP (30X35)		CCET63VKL5682NKZ	*
C477	943134010620S	ELECT CAP 4700UF 25V		CCEA1EH472E	
C480	943134010500S	ELECT CAP 100UF 16V		CCEA1CH101T	
C481-483	943134010590S	ELECT CAP 22UF 50V		CCEA1HH220T	
C484	nsp	CERAMIC CAP 0.022UF 50V ZF		CCFT1H223ZF	
C486	943134010550S	ELECT CAP 2200UF 25V		CCEA1EH222E	
C487	943134010530S	ELECT CAP 1UF 50V		CCEA1HH1R0T	
C488	nsp	CERAMIC CAP 0.01UF 50V ZF		CCFT1H103ZF	
C489	943134010600S	ELECT CAP 3300UF 16V		CCEA1CH332E	
C490	nsp	CERAMIC CAP 0.01UF 50V ZF		CCFT1H103ZF	
C491	943134010500S	ELECT CAP 100UF 16V		CCEA1CH101T	
C492	943134010520S	ELECT CAP 10UF 50V		CCEA1HH100T	
C493	nsp	CERAMIC CAP 470PF 50V KB		CCKT1H471KB	
C494	nsp	MYLAR CAP 2200PF 100V J		HCQ11H222JZT	
C495	nsp	CERAMIC CAP 100PF 50V KB		CCKT1H101KB	
C496	943134010580S	ELECT CAP 220UF 35V		CCEA1VH221T	
C497	nsp	CERAMIC CAP 33PF 50V J		CCCT1H330JC	
C498,499	nsp	SEMICONDUCTOR CAP 0.1UF 50V ZF		CCFT1H104ZF	
C500	943134010500S	ELECT CAP 100UF 16V		CCEA1CH101T	
C502	nsp	MYLAR CAP 0.047UF 50V		HCQ11H473JZT	

Ref. No.	Part No.	Part Name	Remarks	Q'ty	New
C504	943134010600S	ELECT CAP 3300UF 16V		CCEA1CH332E	
C505	943134010680S	ELECT CAP 47UF 50V		CCEA1HH470T	
C508	943134010520S	ELECT CAP 10UF 50V		CCEA1HH100T	
C559	943134010470S	ELECT CAP 0.1UF 50V		CCEA1HH0R1T	
C561	943134010530S	ELECT CAP 1UF 50V		CCEA1HH1R0T	
C563,564	943134010470S	ELECT CAP 0.1UF 50V		CCEA1HH0R1T	
OTHERS PARTS GROUP					
BK41	nsp	PCB BRACKET		CMD1A569	
BN41	nsp	WIRE ASS'Y		CWB3FE03200UZ	
BN42	nsp	WIRE ASS'Y(15P 120MM 2.0MM)		CWB1B01512047	
BN43	nsp	WIRE ASS'Y		CWB4C01520047	
BN44	nsp	WIRE ASS'Y		CWB4B00345047	
BN45	nsp	WIRE ASS'Y		CWE8202200VV	
BN9B	nsp	WAFER CARD CABLE		CJP13GA115ZY	
CN45	nsp	STRAIGHT WAFER 3PIN 2.5MM		CJP03GI237ZW	
CN46	nsp	STRAIGHT WAFER 7PIN 2.5MM		CJP07GI237ZW	
CN47	nsp	WAFER 2PIN 2MM		CJP02KA060ZY	
CN48	nsp	WAFER 2PIN		CJP02GA89ZY	
CN51-55	nsp	WAFER STRAIGHT 2PIN		CJP02GA01ZY	
ET41	nsp	EARTH PALTE		HJT1A025	
F401	nsp	FUSE HOLDER		KJCF5S	
△ F401	90M-FS001420R	FUSE(218Series 250V 3.15A)	1311E2,1311E1C,391EA	KBA2C3150TLEY	△
△ F401	90M-FS001430R	FUSE(218Series 250V 6.3A)	391E3,391E3B	KBA2C6300TLEY	△
JK41	943646010230S	JACK NOSPC6PRRR/BBB	391E3,391E3B,391EA	CJJ5R004U	* △
JK42	943643010150S	JACK NOSPC2PW/R		CJJ4N034U	*
JK43	943643010160S	JACK NOSPC1PBLACK		CJJ4M046U	*
JK44	943646010240S	JACK NOSPC6PRRR/BBB	1311E2,1311E1C	CJJ5R008U	*
JK45	943646010250S	JACK NOSPC4PRR/BB		CJJ5P011U	*
L401-404	943115010260S	SPEAKER COIL (0.5UH)		CLEY0R5KAK	
L405-413	nsp	COPPER WIRE		C3A206	
L415	943115010260S	SPEAKER COIL (0.5UH)		CLEY0R5KAK	
RY41,42	943682010300S	RELAY G5PA-28		CSL3A018ZE	
△ RY43	943682004660S	POWER RERAY G5PA-1		CSL1E002ZE	
RY44	943682000810S	RELAY 12V2C2P		CSL4A016ZU	
RY45	943682010300S	RELAY G5PA-28		CSL3A018ZE	
△ T401	943101009650D	SUB TRANS(6.9V,65mA)	1311E2,391EA	CLT5I022ZE	△
△ T401	943101009660D	SUB TRANS(6.9V,65mA),CHINA	1311E1C	CLT5I022ZH	
△ T401	943101009640D	SUB TRANS(6.9V,65mA)	391E3,391E3B	CLT5I022ZU	△
TH41	943252010310S	POSISTOR ASS'Y(100)		CRTDHTS100180W	

INPUT P.W.B. UNIT ASS'Y

Ref. No.	Part No.	Part Name	Remarks	Q'ty	New
SEMICONDUCTORS GROUP					
IC60	943231010390S	REGULATOR IC KIA7805BPI	CVIKIA7805BPI		*
IC61	943235003810S	IC R2A15218FP	CVIR2A15218FP		
IC62-65	00D2631289900	IC AZ4580MTR-E1	CVIAZ4580MTR-E1		
IC66,67	00D2630934900	IC BA4510F	HVIBA4510F		
IC68	943231010390S	REGULATOR IC KIA7805BPI	CVIKIA7805BPI		*
IC69	943239010400S	REGULATOR IC NJM2845DL133	CVINJM2845DL133		
IC71	00MHC1023409Y	IC NJM2595MTE1	CVINJM2595MTE1		
IC72	00MHC1010455Y	IC R59-4174	HVIMM1511XNRE		
IC73	00MHC1023609Y	IC NJM2586	HVINJM2586AMTE1		
IC74	00D2631099006	REGULATOR IC KIA7905PI	CVIKIA7905PI		
IC81	943245010410S	IC CS497024CVZ	CVICS497024CVZ		*
IC82	943246010420S	IC SST25VF080B-50-4C-S2AF	CVIANAM1530AV		*
IC83	943246010430S	IC M12L16161A5TG	CVIM12L16161A5TG		*
IC84	90M-HC110090R	IC CS42528-CQ	HVICS42528-CQ		
IC85	00D2623198902	IC C74VHC157FT	HVITC74VHC157FT		
IC91	943243009610D	IC U-COM(T5CN5)	CVIANAM1529AV		*
IC92	943246010440S	IC M24C32WMN6TP	CVIM24C32WMN6TP		
IC93	00D2623410907	IC TC74VHCT08AFT	HVITC74VHCT08FT		
IC94	00D2623444902	IC TC74VHC08FT	CVITC74VHC08FT		
IC95	943239010400S	REGULATOR IC NJM2845DL133	CVINJM2845DL133		
IC96	943234010450S	IC BD5225G	CVIBD5225G		
Q901	90M-HX800100R	CHIP TR KTC3875SYRTK	HVTKTC3875SYRTK		
Q903	90M-HX800100R	CHIP TR KTC3875SYRTK	HVTKTC3875SYRTK		
D601,602	943209001080S	DIODE 1SS355	CVD1SS355T		
D605,606	943202010060S	DIODE ZJ7.5B	CVDZJ7.5BT		
D903	943209001080S	DIODE 1SS355	CVD1SS355T		
RESISTORS GROUP					
R736,737	nsp	METAL OXID EFILM RES(68OHM 1W)	CRG1SANJ680RT		
R761-764	nsp	CHIP RES(75OHM 1%)	CRJ10DF75R0T		
R766	nsp	CHIP RES(82OHM 1%)	CRJ10DF82R0T		
R772-777	nsp	CHIP RES(75OHM 1%)	1311E2,1311E1C CRJ10DF75R0T		
R779	nsp	CHIP RES(82OHM 1%)	1311E2,1311E1C CRJ10DF82R0T		
R781	nsp	CHIP RES(82OHM 1%)	1311E2,1311E1C CRJ10DF82R0T		
R783	nsp	CHIP RES(82OHM 1%)	1311E2,1311E1C CRJ10DF82R0T		
R805	nsp	CHIP RES(1.37KOHM 1/16W 1% 1608)	CRJ10DF1371T		
R839	nsp	CHIP RES(5.1K 1%)	CRJ10DF5101T		
R958	nsp	CHIP CAP 0.1uF 50V	CCUS1H104KC		
R607	nsp	RES,CHIP(2.2KOHM,5%,1608)	CRJ10DJ222T		
R608	nsp	RES,CHIP(2.2KOHM,5%,1608)	CRJ10DJ222T		
R609	nsp	RES,CHIP(47KOHM,5%,1608)	CRJ10DJ473T		
R610	nsp	RES,CHIP(47KOHM,5%,1608)	CRJ10DJ474T		
R638	nsp	RES,CHIP(0OHM,5%,1608)	CRJ10DJ0R0T		
R658	nsp	RES,CHIP(0OHM,5%,1608)	CRJ10DJ0R0T		
R659	nsp	RES,CHIP(0OHM,5%,1608)	CRJ10DJ0R0T		
R959	nsp	RES,CHIP(100OHM,5%,1608)	CRJ10DJ101T		

NOTE :
When update Firmware,
please confirm a last
version in SDI.
Use the service board
after updating it.

Ref. No.	Part No.	Part Name	Remarks	Q'ty	New
RN61	nsp	CHIP RES(100OHM 5% 1608X4)	CRJ104DJ101T		
RN80	nsp	CHIP RES(33OHM 5%,1608X4)	CRJ104DJ330T		
RN81,82	nsp	CHIP RES(10KOHM 5% 1608X4)	CRJ104DJ103T		
RN83-90	nsp	CHIP RES(33OHM 5% 1608X4)	CRJ104DJ330T		
RN91,92	nsp	CHIP RES(100OHM 5% 1608X4)	CRJ104DJ101T		
RN93	nsp	CHIP RES(10KOHM 5% 1608X4)	CRJ104DJ103T		
CAPACITORS GROUP					
C603,604	nsp	CHIP CAP	CCUS1H822KC		
C605	nsp	CHIP CAP 0.1UF 50V	CCUS1H104KC		
C606	nsp	CHIP CAP 3900PF 50V K	CCUS1H392KC		
C607	943134010630S	ELECT CAP 470UF 10V	CCEA1AH471T		
C608,609	943134010520S	ELECT CAP 10UF 50V	CCEA1HH100T		
C610,611	nsp	CHIP CAP 100PF 50V	CCUS1H101JA		
C612	nsp	CHIP CAP 0.1UF 50V	CCUS1H104KC		
C613,614	nsp	CHIP CAP 100PF 50V	CCUS1H101JA		
C619,620	nsp	CHIP CAP 220PF 50V	CCUS1H221JA		
C623,624	nsp	CHIP CAP 220PF 50V	CCUS1H221JA		
C627,628	nsp	CHIP CAP 220PF 50V	CCUS1H221JA		
C629	943134010500S	ELECT CAP 100UF 16V	CCEA1CH101T		
C635	nsp	CHIP RES 0OHM 5%	CRJ10DJ0R0T		
C636-639	943134010670S	ELECT CAP 100UF 16V	CCEA1CH101T		
C640	943134010590S	ELECT CAP 22UF 50V	CCEA1HH220T		
C641	943134010670S	ELECT CAP 100UF 16V	CCEA1CH101T		
C642,643	943134010680S	ELECT CAP 47UF 50V	CCEA1HH470T		
C647	nsp	CHIP CAP 0.1UF 50V	CCUS1H104KC		
C651	nsp	CHIP CAP 0.1UF 50V	CCUS1H104KC		
C652-655	nsp	CHIP CAP 1500PF 50VK	CCUS1H152KC		
C656,657	nsp	CHIP CAP 330PF 50V J	CCUS1H331JA		
C658,659	nsp	CHIP CAP 1500PF 50VK	CCUS1H152KC		
C660	nsp	CHIP CAP 0.1UF 50V	CCUS1H104KC		
C661,662	nsp	CHIP CAP 330PF 50V J	CCUS1H331JA		
C663,664	943134010610S	ELECT CAP 4.7UF 50V	CCEA1HH4R7T		
C665	nsp	CHIP CAP 0.1UF 50V	CCUS1H104KC		
C668-670	nsp	CHIP CAP 1500PF 50VK	CCUS1H152KC		
C671	nsp	CHIP CAP 4700PF 50V	CCUS1H472KC		
C672	nsp	CHIP CAP 330PF 50V J	CCUS1H331JA		
C673	nsp	CHIP CAP 1000PF 50V	CCUS1H102KC		
C674	nsp	CHIP CAP 1500PF 50VK	CCUS1H152KC		
C675	nsp	CHIP CAP 4700PF 50V	CCUS1H472KC		
C676	nsp	CHIP CAP 0.1UF 50V	CCUS1H104KC		
C677	nsp	CHIP CAP 3900PF 50V K	CCUS1H392KC		
C678	nsp	CHIP CAP 330PF 50V J	CCUS1H331JA		
C679	nsp	CHIP CAP 1000PF 50V	CCUS1H102KC		
C680,681	943134010610S	ELECT CAP 4.7UF 50V	CCEA1HH4R7T		
C682	nsp	CHIP CAP 0.1UF 50V	CCUS1H104KC		
C685-688	nsp	CHIP CAP 1500PF 50VK	CCUS1H152KC		
C689	nsp	CHIP CAP 330PF 50V J	CCUS1H331JA		
C690	nsp	CHIP CAP 330PF 50V J	CCUS1H331JA		
C691,692	nsp	CHIP CAP 1500PF 50VK	CCUS1H152KC		
C693	nsp	CHIP CAP 0.1UF 50V	CCUS1H104KC		
C694,695	nsp	CHIP CAP 330PF 50V J	CCUS1H331JA		

	Ref. No.	Part No.	Part Name		Remarks	Q'ty	New
	C696,697	943134010610S	ELECT CAP 4.7UF 50V		CCEA1HH4R7T		
	C698	nsp	CHIP CAP 0.1UF 50V		CCUS1H104KC		
	C701-704	nsp	CHIP CAP 1500PF 50VK		CCUS1H152KC		
	C705,706	nsp	CHIP CAP 330PF 50V J		CCUS1H331JA		
	C707,708	nsp	CHIP CAP 1500PF 50VK		CCUS1H152KC		
	C709	nsp	CHIP CAP 0.1UF 50V		CCUS1H104KC		
	C710,711	nsp	CHIP CAP 330PF 50V J		CCUS1H331JA		
	C712,713	943134010610S	ELECT CAP 4.7UF 50V		CCEA1HH4R7T		
	C714	nsp	CHIP CAP 0.1UF 50V		CCUS1H104KC		
	C718	943134010500S	ELECT CAP 100UF 16V		CCEA1CH101T		
	C720	943134010500S	ELECT CAP 100UF 16V		CCEA1CH101T		
	C724-726	943134010500S	ELECT CAP 100UF 16V		CCEA1CH101T		
	C727	nsp	CHIP CAP 0.1UF 50V		CCUS1H104KC		
	C728	943134010500S	ELECT CAP 100UF 16V		CCEA1CH101T		
	C729	nsp	CHIP CAP 0.22UF 16VK		CCUS1C224KC		
	C730	943134010500S	ELECT CAP 100UF 16V		CCEA1CH101T		
	C731	nsp	CHIP CAP 0.1UF 50V		CCUS1H104KC		
	C732	943134010590S	ELECT CAP 22UF 50V		CCEA1HH220T		
	C733	nsp	CHIP CAP 220PF 50V		CCUS1H221JA		
	C735	nsp	CHIP CAP 0.1UF 50V		CCUS1H104KC		
	C736	nsp	CHIP CAP 2700PF 50V K		CCUS1H272KC		
	C737	943134010590S	ELECT CAP 22UF 50V		CCEA1HH220T		
	C738	nsp	CHIP CAP 220PF 50V		CCUS1H221JA		
	C740	nsp	CHIP CAP 0.1UF 50V		CCUS1H104KC		
	C741	nsp	CHIP CAP 2700PF 50V K		CCUS1H272KC		
	C742	943134010500S	ELECT CAP 100UF 16V		CCEA1CH101T		
	C743	nsp	CHIP CAP 0.1UF 50V		CCUS1H104KC		
	C744	943134010530S	ELECT CAP 1UF 50V		CCEA1HH1R0T		
	C745,747	943134010500S	ELECT CAP 100UF 16V		CCEA1CH101T		
	C752	nsp	CHIP RES 00HM 5%		CRJ10DJ0R0T		
	C754,755	943134010520S	ELECT CAP 10UF 50V		CCEA1HH100T		
	C756-758	nsp	CHIP CAP 0.1UF 50V		CCUS1H104KC		
	C759	943134010520S	ELECT CAP 10UF 50V		CCEA1HH100T		
	C763-765	943134010520S	ELECT CAP 10UF 50V		CCEA1HH100T		
	C766	nsp	CHIP CAP 0.1UF 50V		CCUS1H104KC		
	C768	943134010680S	ELECT CAP 47UF 50V		CCEA1HH470T		
	C769	nsp	CHIP CAP 0.1UF 50V		CCUS1H104KC		
	C770	943134010520S	ELECT CAP 10UF 50V		CCEA1HH100T		
	C771	943134010500S	ELECT CAP 100UF 16V		CCEA1CH101T		
	C772	nsp	CHIP CAP 22PF 50V		CCUS1H220JA		
	C778-783	943134010530S	ELECT CAP 1UF 50V	1311E2,1311E1C	CCEA1HH1R0T		
	C785	nsp	CHIP CAP 68PF 50V J	1311E2,1311E1C	CCUS1H680JA		
	C787	nsp	CHIP CAP 68PF 50V J	1311E2,1311E1C	CCUS1H680JA		
	C789	nsp	CHIP CAP 68PF 50V J	1311E2,1311E1C	CCUS1H680JA		
	C790-796	nsp	CHIP CAP 0.1UF 50V	1311E2,1311E1C	CCUS1H104KC		
	C797	943134010520S	ELECT CAP 10UF 50V	1311E2,1311E1C	CCEA1HH100T		
	C799	943134010520S	ELECT CAP 10UF 50V	1311E2,1311E1C	CCEA1HH100T		
	C801	nsp	CHIP CAP 100PF 50V		CCUS1H101JA		
	C802,803	nsp	CHIP CAP 0.1UF 50V		CCUS1H104KC		
	C804	943134010490S	ELECT CAP 100UF 10V		CCEA1AH101T		
	C805	nsp	CHIP CAP 0.1UF 50V		CCUS1H104KC		
	C806	943134010490S	ELECT CAP 100UF 10V		CCEA1AH101T		
	C807	nsp	CHIP CAP 0.1UF 50V		CCUS1H104KC		

Ref. No.	Part No.	Part Name	Remarks	Q'ty	New
C808	943134010610S	ELECT CAP 4.7UF 50V	CCEA1HH4R7T		
C809	nsp	CHIP CAP 0.1UF 50V	CCUS1H104KC		
C810	943134010490S	ELECT CAP 100UF 10V	CCEA1AH101T		
C811	943134010630S	ELECT CAP 470UF 10V	CCEA1AH471T		
C812	nsp	CHIP CAP 0.1UF 50V	CCUS1H104KC		
C813	nsp	CHIP CAP 1000PF 50V	CCUS1H102KC		
C814	nsp	CHIP CAP 0.1UF 50V	CCUS1H104KC		
C815	nsp	CHIP CAP 0.022UF 50VK	CCUS1H223KC		
C816	943134010490S	ELECT CAP 100UF 10V	CCEA1AH101T		
C817	nsp	CHIP CAP 0.1UF 50V	CCUS1H104KC		
C818	nsp	CHIP CAP 0.01UF 50V	CCUS1H103KC		
C819	nsp	CHIP CAP 0.1UF 50V	CCUS1H104KC		
C820	nsp	CHIP CAP 0.1UF 50V	CCUS1H104KC		
C821	nsp	CHIP CAP 0.1UF 50V	CCUS1H104KC		
C822-824	nsp	CHIP CAP 0.01UF 50V	CCUS1H103KC		
C825,826	943134010490S	ELECT CAP 100UF 10V	CCEA1AH101T		
C827	nsp	CHIP CAP 0.1UF 50V	CCUS1H104KC		
C828	nsp	CHIP CAP 100PF 50V	CCUS1H101JA		
C829	nsp	CHIP CAP 0.1UF 50V	CCUS1H104KC		
C830	943134010680S	ELECT CAP 47UF 50V	CCEA1HH470T		
C831,832	nsp	CHIP CAP 0.1UF 50V	CCUS1H104KC		
C835,836	nsp	CHIP CAP 0.1UF 50V	CCUS1H104KC		
C837,838	nsp	CHIP CAP 15PF 50V	CCUS1H150JA		
C839	943134010560S	ELECT CAP 220UF10V	CCEA1AH221T		
C840	nsp	CHIP CAP 1UF 10V	CCUS1A105KC		
C841	nsp	CHIP CAP 0.01UF 50V	CCUS1H103KC		
C842	nsp	CHIP CAP 100PF 50V	CCUS1H101JA		
C843	943134010490S	ELECT CAP 100UF 10V	CCEA1AH101T		
C844-851	nsp	CHIP CAP 0.1UF 50V	CCUS1H104KC		
C859,860	943134010490S	ELECT CAP 100UF 10V	CCEA1AH101T		
C861-868	nsp	CHIP CAP 0.1UF 50V	CCUS1H104KC		
C875-878	nsp	CHIP CAP 0.1UF 50V	CCUS1H104KC		
C879	nsp	CHIP CAP 15PF 50V	CCUS1H150JA		
C880-882	nsp	CHIP CAP 0.1UF 50V	CCUS1H104KC		
C901	nsp	CHIP CAP 0.1UF 50V	CCUS1H104KC		
C902	943134010500S	ELECT CAP 100UF 16V	CCEA1CH101T		
C903	nsp	CHIP CAP 0.22UF 16VK	CCUS1C224KC		
C904	943134010570S	ELECT CAP 220UF 16V	CCEA1CH221T		
C905-909	nsp	CHIP CAP 0.1UF 50V	CCUS1H104KC		
C911	nsp	CHIP CAP 0.1UF 50V	CCUS1H104KC		
C913	nsp	CHIP CAP 0.1UF 50V	CCUS1H104KC		
C914	nsp	CHIP CAP 27PF 50V J	CCUS1H270JA		
C915	nsp	CHIP CAP 22PF 50V	CCUS1H220JA		
C916-918	nsp	CHIP CAP 0.1UF 50V	CCUS1H104KC		
C919	943134010520S	ELECT CAP 10UF 50V	CCEA1HH100T		
C920	nsp	CHIP CAP 0.1UF 50V	CCUS1H104KC		
C921	943134010520S	ELECT CAP 10UF 50V	CCEA1HH100T		
C922	nsp	CHIP CAP 0.1UF 50V	CCUS1H104KC		
C923,924	nsp	CHIP CAP 100PF 50V	CCUS1H101JA		
C928	943134010470S	ELECT CAP 0.1UF 50V	CCEA1HH0R1T		
C929,930	nsp	CHIP CAP 0.1UF 50V	CCUS1H104KC		
C933-935	nsp	CHIP CAP 0.1UF 50V	CCUS1H104KC		
C936-938	nsp	CHIP CAP 1000PF 50V	CCUS1H102KC		

	Ref. No.	Part No.	Part Name		Remarks	Q'ty	New
	TU61	943183010310S	TUNER(EUR)FM,AM,RDS(S/LAB)	1311E2,1311E1C,391EA	CNVMW104MV1S63SN		*
	TU61	943183010320S	TUNER(USA)FM(SCREW:FTYPE),AM(S/LAB)	391E3,391E3B	CNVMW004MV1S63SA		* 
	X801	943141010360S	CRYSTAL 24.576MHz 15PF 30PPM		HOX24576E150TF		
	X901	943141010370S	CRYSTAL 10.000MHz 22PF 30PPM		HOX10000E220TF		

HDM P.W.B. UNIT ASS'Y

	Ref. No.	Part No.	Part Name		Remarks	Q'ty	New
SEMICONDUCTORS GROUP							
	IC11	943236010380S	IC ADV7622BSTZ		CVIADV7622BSTZ		*
	IC15	943239010400S	REGULATOR IC NJM2845DL133		CVINJM2845DL133		
	IC16	nsp	IC EX3AV		CVIEX3AV		
	Q101	00D2690184907	CHIP TR KRA102S		HVTKRA102S		
	Q102	90M-BA001620R	CHIP TR KRC103S		CVTKRC103S		
	Q103	00D2690184907	CHIP TR KRA102S		HVTKRA102S		
	Q104	90M-BA001620R	CHIP TR KRC103S		CVTKRC103S		
	Q105	00D2690184907	CHIP TR KRA102S		HVTKRA102S		
	Q106	90M-BA001620R	CHIP TR KRC103S		CVTKRC103S		
	Q107	00D2690184907	CHIP TR KRA102S		HVTKRA102S		
	Q108	90M-BA001620R	CHIP TR KRC103S		CVTKRC103S		
RESISTORS GROUP							
	RN11,12	nsp	RESNETWORK CHIP (33ohm 1/16W)		CRJ064IJ330T		
CAPACITORS GROUP							
	C101-129	nsp	CHIP CAP 0.1UF 16V		CCUI1C104KC		
	C130	nsp	CHIP CAP 10UF 6.3V		CCUC0J106KC		
	C131	nsp	CHIP CAP 0.1UF 16V		CCUI1C104KC		
	C132	nsp	CHIP CAP 10UF 6.3V		CCUC0J106KC		
	C133	nsp	CHIP CAP 0.1UF 16V		CCUI1C104KC		
	C134	nsp	CHIP CAP 10UF 6.3V		CCUC0J106KC		
	C135	nsp	CHIP CAP 0.1UF 16V		CCUI1C104KC		
	C136	nsp	CHIP CAP 10UF 6.3V		CCUC0J106KC		
	C138	nsp	CHIP CAP 0.1UF 16V		CCUI1C104KC		
	C139	nsp	CHIP CAP 10UF 6.3V		CCUC0J106KC		
	C140	nsp	CHIP CAP 0.1UF 16V		CCUI1C104KC		
	C141	nsp	CHIP CAP 10UF 6.3V		CCUC0J106KC		
	C144	nsp	CHIP CAP 0.1UF 50V		CCUS1H104KC		
	C145,146	nsp	CHIP CAP 47PF 50V		CCUS1H470JA		
	C147	nsp	CHIP CAP 0.1UF 16V		CCUI1C104KC		
	C148	nsp	CHIP CAP 10UF 6.3V		CCUC0J106KC		
	C149	nsp	CHIP CAP 0.1UF 16V		CCUI1C104KC		
	C150	nsp	CHIP CAP 10UF 6.3V		CCUC0J106KC		
	C161	nsp	CHIP CAP 1UF 10V		CCUS1A105KC		
	C162	nsp	CHIP CAP 0.1UF 16V		CCUI1C104KC		
	C163	nsp	CHIP CAP 0.1UF 16V		CCUI1C104KC		
	C164	nsp	CHIP CAP 10UF 6.3V		CCUC0J106KC		
	C165	nsp	CHIP CAP 0.1UF 16V		CCUI1C104KC		
	C166	nsp	CHIP CAP 0.22UF 16V		CCUS1C224KC		
	C167	nsp	CHIP CAP 10UF 6.3V		CCUC0J106KC		
	C171	nsp	CHIP CAP 10UF 6.3V		CCUC0J106KC		
	C172	nsp	CHIP CAP 0.1UF 16V		CCUI1C104KC		
	C173	nsp	CHIP CAP 22UF 6.3V		CCUP0J226KC		
	C174	nsp	CHIP CAP 10UF 6.3V		CCUC0J106KC		
	C175	nsp	CHIP CAP 0.1UF 16V		CCUI1C104KC		
	C176	nsp	CHIP CAP 10UF 6.3V		CCUC0J106KC		

Ref. No.	Part No.	Part Name	Remarks	Q'ty	New
C178	nsp	CHIP CAP 0.015UF 25V	CCUI1E153KC		
C179	nsp	CHIP CAP 15PF 50V	CCUI1H150JA		
OTHERS PARTS GROUP					
BK11,12	nsp	PCB BRACKET	CMD1A569		
CN12	nsp	WAFER SMD(2MMPITCH)	CJP05GA208ZY		
CN8B	nsp	WAFER	CJP19GA115ZY		
JK11-15	644010108608S	HDMI JACK(SMD)	CJJ9H010Z		
L101-108	nsp	CHIP FERRITE BEAD(60ohm 1608)	CLZ9R005Z		
L109	nsp	CHIP FERRITE BEAD(60ohm 4516)	CLZ9Z014Z		
L114	nsp	CHIP FERRITE BEAD(60ohm 1608)	CLZ9R005Z		
TW91	nsp	WIRE ASS'Y 2P(100MM)	CWZPM5003TW91		
X101	943141010350S	CRYSTAL 28.636MHz 33PF 30PPM	COX28636E330S		

SYS-391HT section

SPEAKER SYSTEM PACK

TECHNICAL SPECIFICATIONS

□ Front speaker (SC-F391)

Type: 2-way, 3-speakers
Closed box / Low-leakage-flux

Drive units: 8 cm cone bass-mid x 2
2.5 cm high range x 1

Input impedance: 6 Ω

Max. input: 60 W (IEC)
120 W (PEAK)

Frequency range: 150 Hz – 22 kHz

Dimensions: 125 (W) x 320 (H) x 155 (D) mm
(4-59/64" x 12-19/32" x 6-7/64")

Weight: 2.0 kg (4 lbs 6.6 oz)

□ Center speaker (SC-C391)

Type: 2-way, 3-speakers
Closed box / Low-leakage-flux

Drive units: 8 cm cone bass mid x 2
2.5 cm high range x 1

Input impedance: 6 Ω

Max. input: 60 W (IEC)
120 W (PEAK)

Frequency range: 150 Hz – 22 kHz

Dimensions: 320 (W) x 125 (H) x 155 (D) mm
(12-19/32" x 4-59/64" x 6-7/64")

Weight: 2.0 kg (4 lbs 6.6 oz)

□ Surround speaker (SC-R391)

Type: Full-range, 1-speaker
Closed box

Drive units: 8 cm cone full range x 1

Input impedance: 6 Ω

Max. input: 60 W (IEC)
120 W (PEAK)

Frequency range: 150 Hz – 20 kHz

Dimensions: 125 (W) x 180 (H) x 155 (D) mm
(4-59/64" x 7-3/32" x 6-7/64")

Weight: 1.1 kg (2 lbs 6.8 oz)

□ Subwoofer (DSW-391)

Type: Reflex box
Built-in amplifier

Drive unit: 20 cm cone woofer x 1

Frequency range: 20 Hz – 150 Hz

Dynamic power: 100 W

Input impedance: 22 kΩ

Power supply: 120 V / 60 Hz (North America/Brazilian model)
230 V / 50 Hz (European model/Australian model)

Power consumption: 65 W
MAX. 0.5 W (Standby)

Dimensions: 280 (W) x 356 (H) x 410 (D) mm
(11-1/32" x 14-1/64" x 16-9/64")

Weight: 10.4 kg (22 lbs 14.8 oz)

DIMENSION

[SC-C391]

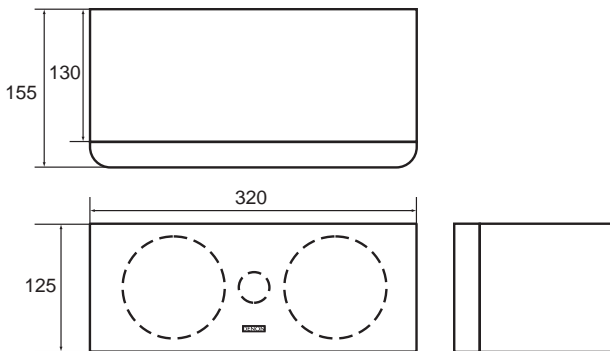

[SC-R391]

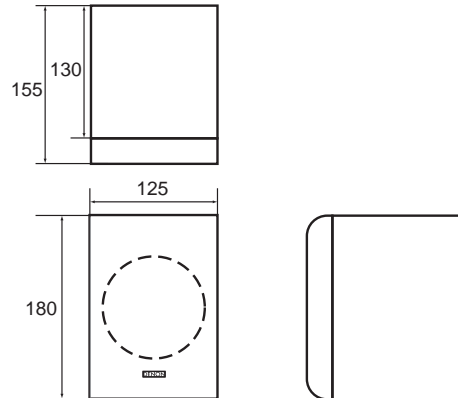

[SC-F391]

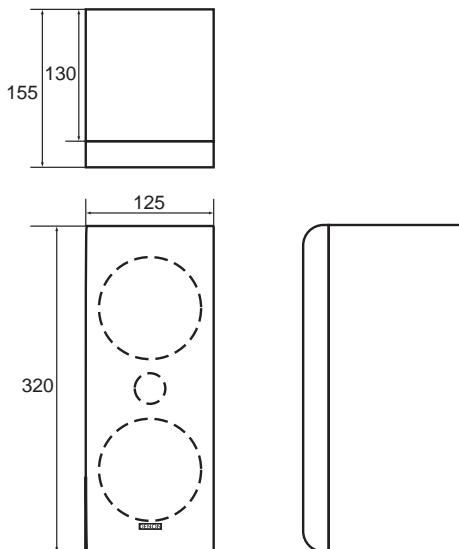

[DSW-391]

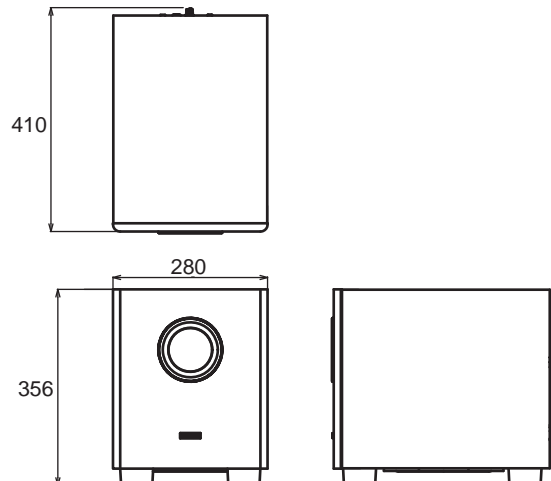

SC-F391 EXPLODED VIEW

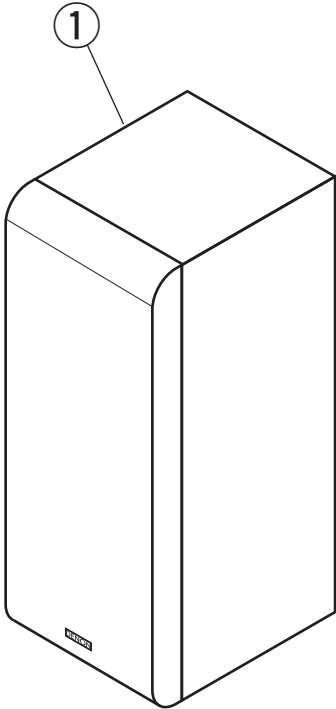

SC-F391 PARTS LIST OF EXPLODED VIEW

* Parts for which "nsp" is indicated on this table cannot be supplied.
 * The parts listed below are for maintenance only, might differ from the parts used in the unit in appearances or dimensions.

Ref. No.	Part No.	Part Name	Remarks	Q'ty	New
1	984189000120D	SPEAKER ASS'Y		00N-SCF391CKD	1 *

SC-R391 EXPLODED VIEW

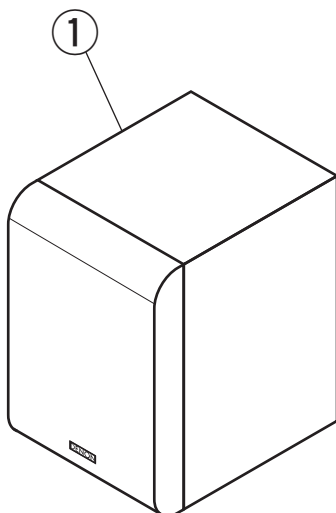

SC-R391 PARTS LIST OF EXPLODED VIEW

* Parts for which "nsp" is indicated on this table cannot be supplied.

* The parts listed below are for maintenance only, might differ from the parts used in the unit in appearances or dimensions.

Ref. No.	Part No.	Part Name	Remarks	Q'ty	New
1	984189000140D	SPEAKER ASS'Y		00N-SCR391CKD 1	*

SC-C391 EXPLODED VIEW

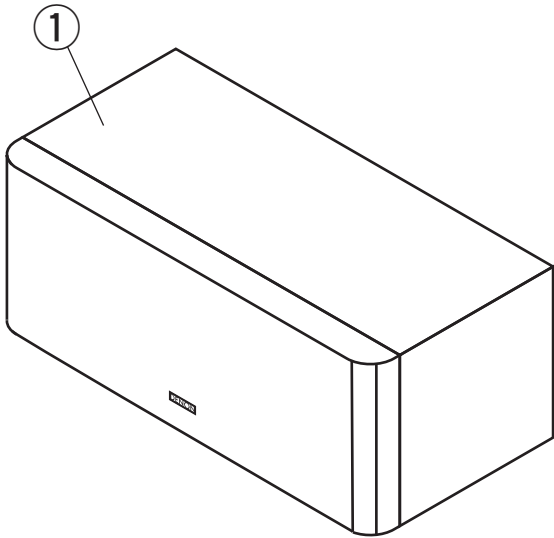

SC-C391 PARTS LIST OF EXPLODED VIEW

* Parts for which "nsp" is indicated on this table cannot be supplied.
 * The parts listed below are for maintenance only, might differ from the parts used in the unit in appearances or dimensions.

Ref. No.	Part No.	Part Name	Remarks	Q'ty	New
1	984189000130D	SPEAKER ASS'Y		00N-SCC391CKD 1	*

DSW-391 EXPLODED VIEW

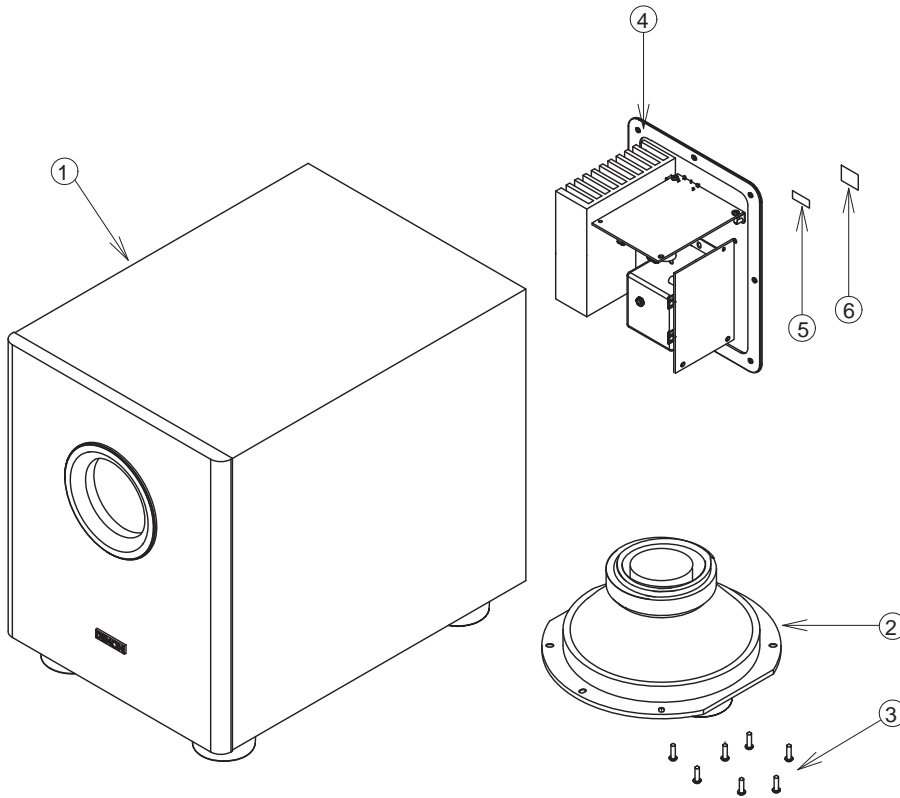

DSW-391 PARTS LIST OF EXPLODED VIEW

* Parts for which "nsp" is indicated on this table cannot be supplied.

* The parts listed below are for maintenance only, might differ from the parts used in the unit in appearances or dimensions.

Note: The symbols in the column "Remarks" indicate the following destinations.

E3 : U.S.A. and Canada model

E3B : Brazil model

E2 : Europe model

EA : Australia model

Ref. No.	Part No.	Part Name	Remarks		Q'ty	New
1	nsp	CABINET ASSY		-	1	*
2	984323000180D	DRIVER		304-00044-00	1	*
3	nsp	SCREW		S411-A4020E1J	14	*
4	984189000150D	AMPLIFIER	E2	326-W391CE-K0	1	*
4	984189000160D	AMPLIFIER	E3	326-W391UL-K0	1	*
4	984189000170D	AMPLIFIER	EA	326-W391AU-K0	1	*
4	984189000190D	AMPLIFIER	E3B	326-W391UB-K0	1	*
5	nsp	SAFETY LABEL	E2,EA	660-00W391-00	1	*
5	nsp	SAFETY LABEL	E3	660-10W391-00	1	*
6	nsp	SPEC LABEL	E2	600-00W391-00	1	*
6	nsp	SPEC LABEL	E3,E3B	600-10W391-00	1	*

SYS-391HT PACKING VIEW

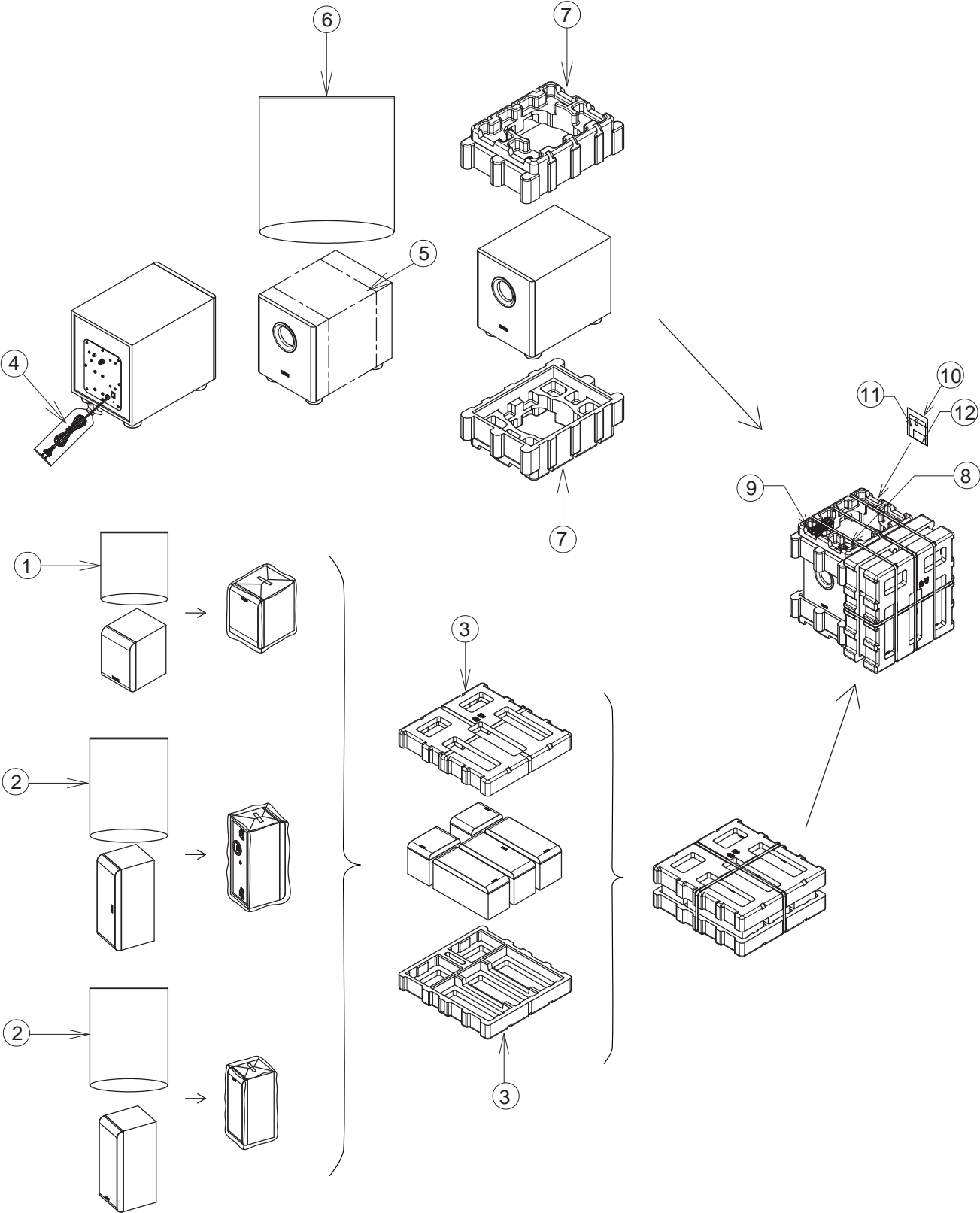

SYS-391HT PARTS LIST OF PACKING VIEW

* Parts for which "nsp" is indicated on this table cannot be supplied.

* The parts listed below are for maintenance only, might differ from the parts used in the unit in appearances or dimensions.

Note: The symbols in the column "Remarks" indicate the following destinations.

E3 : U.S.A. and Canada model

E3B : Brazil model 

E2 : Europe model

EA : Australia model

Ref. No.	Part No.	Part Name	Remarks		Q'ty	New
1	nsp	PE BAG		710-140034-00	1	*
2	nsp	PE BAG		710-140033-00	1	*
3	nsp	POLYFORM		720-F3910S-00	2	*
4	nsp	PE BAG		700-220001-00	1	*
5	nsp	MIRROR MAT		715-140028-00	1	*
6	nsp	PE BAG		700-120003-00	1	*
7	nsp	POLYFORM		720-W3910S-00	2	*
8	nsp	FOOT ASSY		755-C13001-00	1	*
9	nsp	CABLE ASSY		319-W39101-10	1	*
10	nsp	PE BAG		700-120006-00	1	*
11	nsp	CONTROL LABEL	E3	605-0W391U-00	2	*
11	nsp	CONTROL LABEL	E2	605-0W391C-00	2	*
11	nsp	CONTROL LABEL	EA	605-0W391E-00	2	*
11	nsp	CONTROL LABEL	E3B	605-0W391B-00	2	*
12	nsp	ATCM LABEL	E3	670-001001-00	1	*



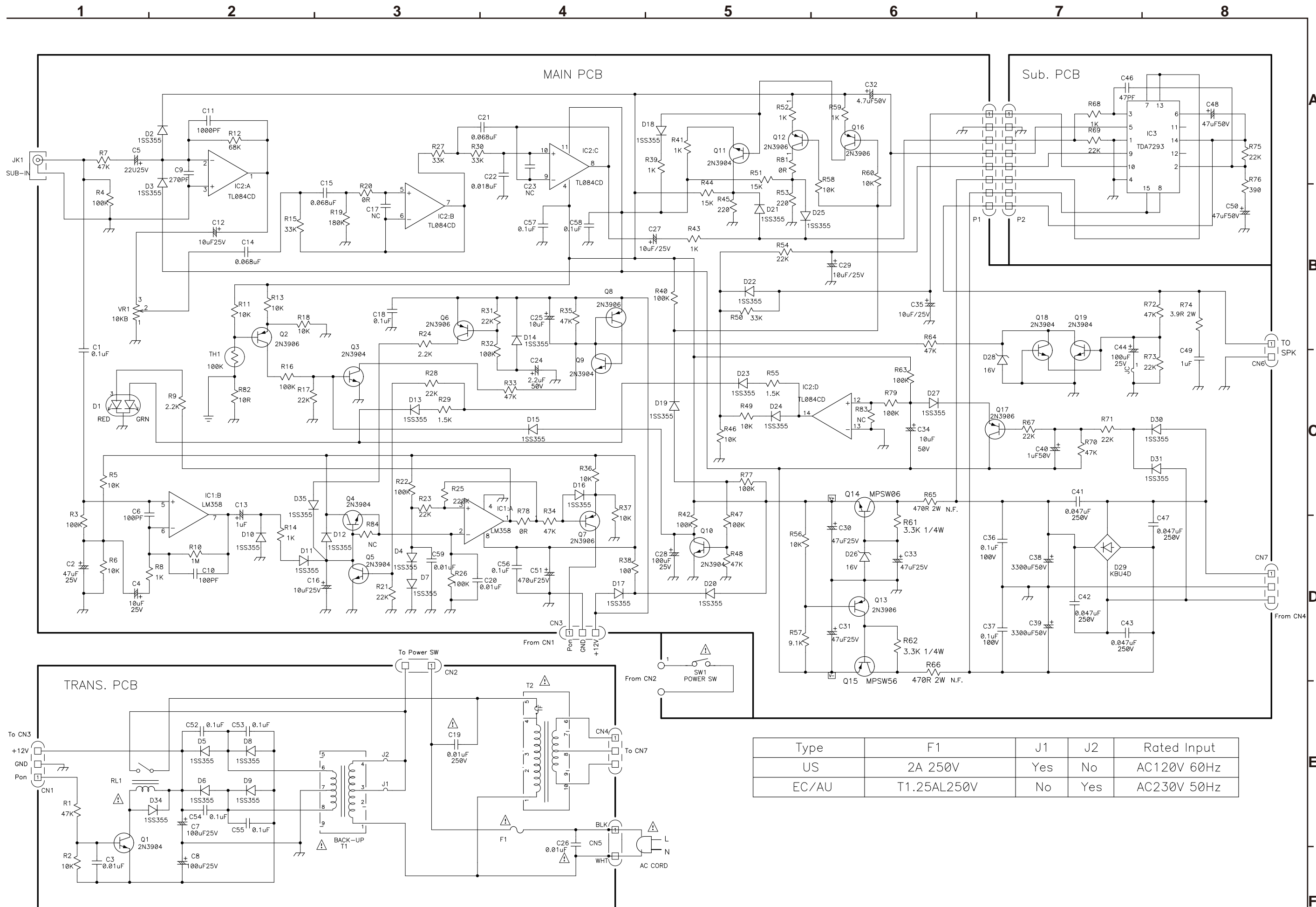

Type	F1	J1	J2	Rated Input
US	2A 250V	Yes	No	AC120V 60Hz
EC/AU	T1.25AL250V	No	Yes	AC230V 50Hz

SCHMATIC DIAGRAMS (1/1)