

DENON

Hi-Fi AV Surround Receiver

For Europe and Asia Models

SERVICE MANUAL

MODEL AVR-1400/1420

AV SURROUND RECEIVER

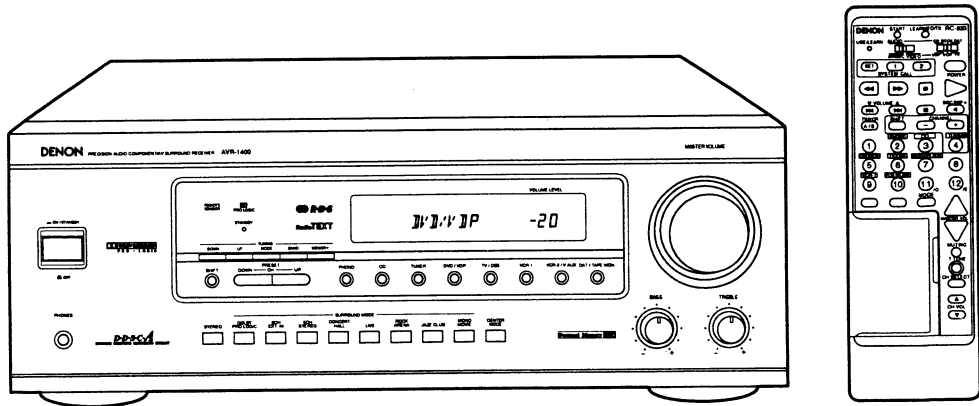

AVR-1420 has the accessories with wood board.

This service manual is supplement for Europe and Asia models. For servicing, refer to the service manual of AVR-1400 (For U.S.A./Canada model) already issued at the same time.

— TABLE OF CONTENTS —

OPERATING INSTRUCTIONS (RDS operation only)	2,3
NOTE FOR PARTS LIST	3
ADDENDUM PARTS LIST OF PRINTED WIRING BOARD	4,5
ADDENDUM PARTS LIST OF EXPLODED VIEW	6
EXPLODED VIEW OF CHASSIS AND CABINET	7
ADDITIONAL SEMICONDUCTORS	8
WIRE ARRANGEMENT	8

● In order to explain clearly, some illustrations using in this service manual may be slightly different from the actual set.

NIPPON COLUMBIA CO., LTD.

Recalling preset stations

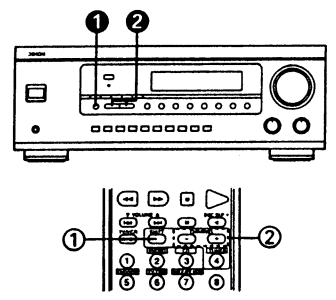

- 1 Watching the display, press the SHIFT button to select the preset memory block.
- 2 Watching the display, press the PRESET UP or DOWN button to select the desired preset channel.

RDS (Radio Data System)

RDS (works only on the FM band) is a broadcasting service which allows station to send additional information along with the regular radio program signal. The following three types of RDS information can be received on this unit:

Program Type (PTY)

PTY identifies the type of RDS program. The program types and their displays are as follows:

NEWS	News	DRAMA	Drama	ROCK M	Rock Music
AFFAIRS	Affairs	CULTURE	Culture	M. O. R. M	M.O.R. Music
INFO	Information	SCIENCE	Science	LIGHT M	Light Classical
SPORT	Sports	VARIED	Varied	CLASSICS	Serious Classical
EDUCATE	Education	POP M	Pop Music	OTHER M	Other Music

Traffic Program (TP)

TP identifies programs that carry traffic announcements. This allows you to easily find out the latest traffic conditions in your area before you leaving home.

Radio Text (RT)

RT allows the RDS station to send text messages that appear on the display.

NOTE:

The operations described below using the RDS, TPY and RD buttons will not function in areas in which there are no RDS broadcasts.

RDS search

Use this function to automatically tune to FM stations that provide RDS service.

- 1 Set the input function to "TUNER".

Set the slide switch to "AUDIO".
- 2 Press the RDS button until "RDS SEARCH" appears on the display.
- 3 Press the PRESET UP or DOWN button to automatically begin the RDS search operation.

If no RDS stations is found with above operation, all the reception band are searched.
- 4 When a broadcast station is found, that station's name appears on the display.
- 5 To continue searching, repeat step 3. If no other RDS station is found when all the frequencies are searched, "NO RDS" is displayed.

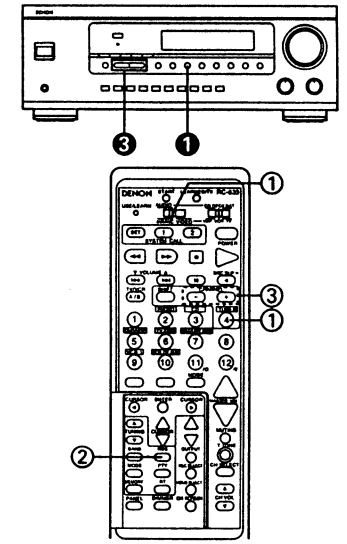

PTY search

Use this function to find RDS stations broadcasting a designated program type (PTY).
For a description of each program type, refer to "Program Type (PTY)".

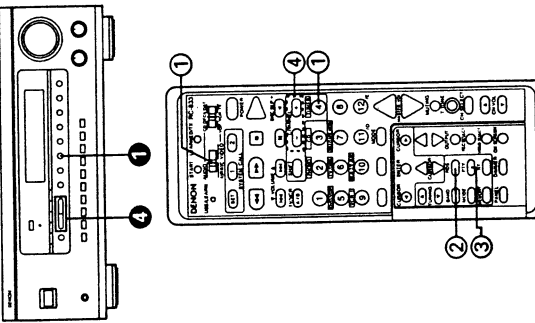

- 1 Set the input function to "TUNER".
Set the slide switch to "AUDIO".
- 2 Press the RDS button until "PTY SEARCH" appears on the display.
- 3 Watching the display, press the PTY button to call out the desired program type.
- 4 Press the PRESET UP or DOWN button to automatically begin the PTY search operation.

If there is no station broadcasting the designated program type with above operation, all the reception bands are searched.

- 5 The station name is displayed on the display after searching stops.

- 6 To continue searching, repeat step 4.
If no other station broadcasting the designated program type is found when all the frequencies are searched, "NO PROGRAMME" is displayed.

TP search

Use this function to find RDS stations broadcasting traffic program (TP stations).

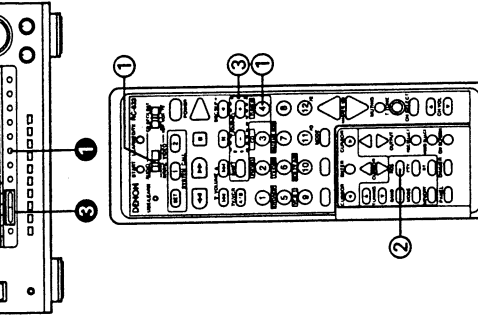

- 1 Set the input function to "TUNER".
Set the slide switch to "AUDIO".
- 2 Press the RDS button until "TP SEARCH" appears on the display.
- 3 Press the PRESET UP or DOWN button TP search begins.
If no TP station is found with above operation, all the reception bands are searched.
- 4 The station name is displayed on the display after searching stops.

To continue searching, repeat step 3.
If no other TP station is found when all the frequencies are searched, "NO PROGRAMME" is displayed.

RT (Radio Text)

"RT" appears on the display when radio text data is received.
When the RT button is pressed while receiving an RDS broadcast station, the text data broadcast from the station is displayed. To turn the display off, press the RT button again. If no text data is being broadcast, "NO TEXT DATA" is displayed.

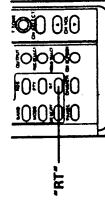

9 LAST FUNCTION MEMORY

- This unit is equipped with a last function memory which stores the input and output setting conditions as they were immediately before the power is switched off.
- The unit is also equipped with a back-up memory. This function provides approximately one week of memory storage when the main unit's power switch is off and with the power cord disconnected.

10 INITIALIZATION OF THE MICROPROCESSOR

When the indication of the display is not normal or when the operation of the unit does not show the reasonable result, the initialization of the microprocessor is required by the following procedure.

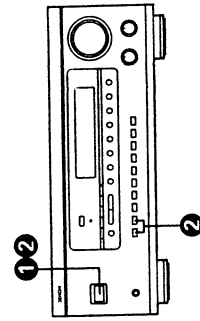

- 1 Switch off the unit using the main unit's POWER operation switch.
- 2 Hold the following STEREO button and DOLBY PRO LOGIC button, and turn the main unit's POWER operation switch on.
- 3 Check that the entire display is flashing with an interval of about 1 second, and release your fingers from the 2 buttons and the microprocessor will be initialized.

13

NOTE FOR PARTS LIST

- Part indicated with the mark "O" are not always in stock and possibly to take a long period of time for supplying, or in some case supplying of part may be refused.
- When ordering of part, clearly indicate "1" and "I" (i) to avoid mis-supplying.
- Ordering part without stating its part number can not be supplied.
- Part indicated with the mark "*" is not illustrated in the exploded view.
- Not including Carbon Film ±5%, 1/4W Type in the P.W.Board parts list. (Refer to the Schematic Diagram for those parts.)

WARNING:

Parts marked with this symbol have critical characteristics.
Use ONLY replacement parts recommended by the manufacturer.

Resistors

Ex.: RN 14K 2E 182 G ER Others
Type Shape Power Resist- Allowable Error Others
and performance strength

RD : Carbon	2B : 1/8W	F : ±1%	P : Pulse-resistant type
RC : Composition	2E : 1/4W	G : ±2%	NL : Low noise type
RS : Metal oxide film	2H : 1/2W	J : ±5%	NB : Non-burning type
RW : Winding	3A : 1W	K : ±10%	FR : Fuse-resistor
RN : Metal film	3D : 2W	M : ±20%	F : Lead wire forming
RK : Metal mixture	3F : 3W		
	3H : 5W		

*** Resistance**

$\overset{1}{\text{---}}\overset{B}{\text{---}}\overset{2}{\text{---}}$ ⇒ 1800 ohm = 1.8 kohm
Indicates number of zeros after effective number.
2-digit effective number.
• Units: ohm

$\overset{1}{\text{---}}\overset{B}{\text{---}}\overset{2}{\text{---}}$ ⇒ 1.2 ohm
1-digit effective number.
2-digit effective number, decimal point indicated by R.
• Units: ohm

Capacitors

Ex.: CE 04W 1H 2R2 M BP
Type Shape Dielectric Capacity Allowable Others
and performance strength error

CE : Aluminum foil electrolytic	0J : 6.3V	F : ±1%	HS : High stability type
CA : Aluminum solid electrolytic	1A : 10V	G : ±2%	BP : Non-polar type
CS : Tantalum electrolytic	1C : 16V	J : ±5%	HR : Ripple-resistant type
CO : Film	1E : 25V	K : ±10%	DL : For change and discharge
CK : Ceramic	1V : 35V	M : ±20%	HF : For assuring high frequency
CC : Ceramic	1H : 50V	Z : +80%	U : UL part
CP : Oil	2A : 100V	-20%	C : CSA part
CM : Mica	2B : 125V	P : +100%	W : UL-CSA type
CF : Metallized	2C : 160V	-0%	F : Lead wire forming
CH : Metallized	2D : 200V	C : ±0.25pF	
	2E : 250V	D : ±0.5pF	
	2H : 500V	= : Others	
	2J : 630V		

*** Capacity (electrolyte only)**

$\overset{2}{\text{---}}\overset{2}{\text{---}}\overset{2}{\text{---}}$ ⇒ 2200µF
Indicates number of zeros after effective number.
2-digit effective number.
• Units: µF

$\overset{2}{\text{---}}\overset{R}{\text{---}}\overset{2}{\text{---}}$ ⇒ 2.2µF
1-digit effective number.
2-digit effective number, decimal point indicated by R.
• Units: µF

*** Capacity (except electrolyte)**

$\overset{2}{\text{---}}\overset{2}{\text{---}}\overset{2}{\text{---}}$ ⇒ 2200pF=0.0022µF
(More than 2) — Indicates number of zeros after effective number.
2-digit effective number.
• Units: µF

$\overset{2}{\text{---}}\overset{2}{\text{---}}\overset{1}{\text{---}}$ ⇒ 220pF
(0 or 1) — Indicates number of zeros after effective number.
2-digit effective number.
• Units: pF

• When the dielectric strength is indicated in AC, "AC" is included after the dielectric strength value.

ADDENDUM PARTS LIST OF P.W.BOARD

1U-3063 AUDIO IN DISP . UNIT

Ref. No.	U.S.A. Model		Europe Model		Asia Model		Taiwan R.O.C Model		Remarks
	Part No.	Part Name	Part No.	Part Name	Part No.	Part Name	Part No.	Part Name	
	1U-3063	Audio in disp p.w.b. unit	1U-3063A	Audio in disp p.w.b. unit	1U-3063A	Audio in disp p.w.b. unit	1U-3063	Audio in disp p.w.b. unit	
R601,602	247 0018 905	Carbon chip 0 ohm 1/10W ±10%	247 0007 974	Carbon chip 1.3 kohm 1/10W ±5%	247 0007 974	Carbon chip 1.3 kohm 1/10W ±5%	247 0018 905	Carbon chip 0 ohm 1/10W ±10%	
C205,206	253 4537 924	Ceramic 33 pF/50V ±5%	253 1179 987	Ceramic 470 pF/50V ±10%	253 1179 987	Ceramic 470 pF/50V ±10%	253 4537 924	Ceramic 33pF/50V ±10%	
C617-626	—	—	257 0005 986	Ceramic chip 330 pF/50V ±5%	257 0005 986	Ceramic chip 330pF/50V ±5%	—	—	
LF601,602	—	—	235 9003 002	FTZ choke coil	235 9003 002	FTZ choke coil	—	—	

1U-3064 TU VR VIDEO UNIT

Ref. No.	U.S.A. Model		Europe Model		Asia Model		Taiwan R.O.C Model		Remarks
	Part No.	Part Name	Part No.	Part Name	Part No.	Part Name	Part No.	Part Name	
	1U-3064	TU VR video p.w.b. unit	1U-3064B	TU VR video p.w.b. unit	1U-3064A	TU VR video p.w.b. unit	1U-3064E	TU VR video p.w.b. unit	
C518	—	—	257 0005 960	Ceramic chip 270 pF/50V ±5%	—	—	—	—	
C519	—	—	257 0004 961	Ceramic chip 100 pF/50V ±5%	—	—	—	—	
C527	254 4260 948	Electrolytic 1 μ/50V ±20%	254 4260 922	Electrolytic 0.33 μF/50V ±20%	254 4260 922	Electrolytic 0.33 μ/50V ±20%	254 4260 922	Electrolytic 0.33 μ/50V ±20%	
C536	257 0004 961	Ceramic chip 100 pF/50V ±5%	—	—	257 0004 961	Ceramic chip 100 pF/50V ±5%	257 0004 961	Ceramic chip 100 pF/50V ±5%	
C537	—	—	254 4254 912	Electrolytic 22 μF/16V ±20%	—	—	—	—	
C539,540	257 0006 972	Ceramic chip 750 pF/50V ±5%	257 0005 986	Ceramic chip 330 pF/50V ±5%	257 0006 930	Ceramic chip 510 pF/50V ±5%	257 0006 930	Ceramic chip 510 pF/50V ±5%	
C564,565	—	—	257 0005 986	Ceramic chip 330 pF/50V ±5%	257 0005 986	Ceramic chip 330 pF/50V ±5%	—	—	
C701,702	—	—	257 0005 986	Ceramic chip 330 pF/50V ±5%	257 0005 986	Ceramic chip 330 pF/50V ±5%	—	—	
C707,708	—	—	257 0004 961	Ceramic chip 100 pF/50V ±5%	257 0004 961	Ceramic chip 100 pF/50V ±5%	—	—	
C715,716	—	—	257 0005 986	Ceramic chip 330 pF/50V ±5%	257 0005 986	Ceramic chip 330 pF/50V ±5%	—	—	
C729,730	—	—	257 0005 986	Ceramic chip 330 pF/50V ±5%	257 0005 986	Ceramic chip 330 pF/50V ±5%	—	—	
CF501	261 0135 907	Ceramic filter MA8	261 0146 006	Ceramic filter FMCFSK107M2-A	261 0135 907	Ceramic filter MA8	261 0135 907	Ceramic filter MA8	
CF502	261 0136 906	Ceramic filter MS2G	261 0146 006	Ceramic filter FMCFSK107M2-A	261 0136 906	Ceramic filter MS2G	261 0136 906	Ceramic filter MS2G	
IC501	216 0102 008	Front end	216 9013 004	FM front end (U) S	216 0102 008	Front end	216 0102 008	Front end	
LF501	—	—	232 9010 009	Antibirdie filter	—	—	—	—	
LF503,504	—	—	232 0085 004	LPF	—	—	—	—	
R502	—	—	247 0018 905	Carbon chip 0 ohm 1/10W ±10%	—	—	—	—	
R515	247 0005 905	Carbon chip 100 ohm 1/10W ±5%	—	—	247 0005 905	Carbon chip 100 ohm 1/10W ±5%	247 0005 905	Carbon chip 100 ohm 1/10W ±5%	
R516	247 0007 945	Carbon chip 1 kohm 1/10W ±5%	247 0006 920	Carbon chip 330 ohm 1/10W ±5%	247 0007 945	Carbon chip 1 kohm 1/10W ±5%	247 0007 945	Carbon chip 1 kohm 1/10W ±5%	
R517	—	—	247 0006 920	Carbon chip 330 ohm 1/10W ±5%	—	—	—	—	
R535	247 0010 945	Carbon chip 18 kohm 1/10W ±5%	247 0011 928	Carbon chip 39 kohm 1/10W ±5%	247 0011 928	Carbon chip 39 kohm 1/10W ±5%	247 0011 928	Carbon chip 39 kohm 1/10W ±5%	
R536	247 0018 905	Carbon chip 0 ohm 1/10W ±10%	247 0008 944	Carbon chip 2.7 kohm 1/10W ±5%	247 0018 905	Carbon chip 0 ohm 1/10W ±10%	247 0018 905	Carbon chip 0 ohm 1/10W ±10%	
R544,545	247 0012 927	Carbon chip 100 kohm 1/10W ±5%	247 0012 969	Carbon chip 150 kohm 1/10W ±5%	247 0012 927	Carbon chip 100 kohm 1/10W ±5%	247 0012 927	Carbon chip 100 kohm 1/10W ±5%	
R555,556	247 0009 927	Carbon chip 5.6 kohm 1/10W ±5%	247 0008 960	Carbon chip 3.3 kohm 1/10W ±5%	247 0009 927	Carbon chip 5.6 kohm 1/10W ±5%	247 0009 927	Carbon chip 5.6 kohm 1/10W ±5%	
R575,576	247 0012 943	Carbon chip 120 kohm 1/10W ±5%	247 0012 998	Carbon chip 200 kohm 1/10W ±5%	247 0012 943	Carbon chip 120 kohm 1/10W ±5%	247 0012 943	Carbon chip 120 kohm 1/10W ±5%	
R579	247 0018 905	Carbon chip 0 ohm 1/10W ±10%	—	—	247 0018 905	Carbon chip 0 ohm 1/10W ±10%	247 0018 905	Carbon chip 0 ohm 1/10W ±10%	
R580,581	247 0018 905	Carbon chip 0 ohm 1/10W ±10%	—	—	247 0018 905	Carbon chip 0 ohm 1/10W ±10%	247 0018 905	Carbon chip 0 ohm 1/10W ±10%	
R645	—	—	247 0009 985	Carbon chip 10 kohm 1/10W ±5%	—	—	—	—	
R646	—	—	247 0009 927	Carbon chip 5.6 kohm 1/10W ±5%	—	—	—	—	
R705	247 0006 962	Carbon chip 470 ohm 1/10W ±5%	247 0005 905	Carbon chip 100 ohm 1/10W ±5%	247 0005 905	Carbon chip 100 ohm 1/10W ±5%	247 0006 962	Carbon chip 470 ohm 1/10W ±5%	
R706	247 0006 962	Carbon chip 470 ohm 1/10W ±5%	247 0005 905	Carbon chip 100 ohm 1/10W ±5%	247 0005 905	Carbon chip 100 ohm 1/10W ±5%	247 0006 962	Carbon chip 470 ohm 1/10W ±5%	
R721,722	247 0006 962	Carbon chip 470 ohm 1/10W ±5%	247 0005 905	Carbon chip 100 ohm 1/10W ±5%	247 0005 905	Carbon chip 100 ohm 1/10W ±5%	247 0006 962	Carbon chip 470 ohm 1/10W ±5%	
R737,738	247 0006 962	Carbon chip 470 ohm 1/10W ±5%	247 0005 905	Carbon chip 100 ohm 1/10W ±5%	247 0005 905	Carbon chip 100 ohm 1/10W ±5%	247 0006 962	Carbon chip 470 ohm 1/10W ±5%	
R793-798	247 0018 905	Carbon chip 0 ohm 1/10W ±10%	247 0006 962	Carbon chip 470 ohm 1/10W ±5%	247 0006 962	Carbon chip 470 ohm 1/10W ±5%	247 0018 905	Carbon chip 0 ohm 1/10W ±10%	
TR501	—	—	275 0074 902	FET 2SK211-Y/GR	—	—	—	—	

1U-3065 CONTROL POWER UNIT

Ref. No.	U.S.A. Model		Europe Model		Asia Model		Taiwan R.O.C Model		Remarks
	Part No.	Part Name	Part No.	Part Name	Part No.	Part Name	Part No.	Part Name	
	1U-3065	Control power p.w.b. unit	1U-3065B	Control power p.w.b. unit	1U-3065A	Control power p.w.b. unit	1U-3065A	Control power p.w.b. unit	
C165,166	—	—	257 0003 920	Ceramic chip 27 pF/50V ±5%	—	—	—	—	
C167	—	—	254 4260 951	Electrolytic 2.2 μF/50V ±20%	—	—	—	—	
C168	—	—	254 4193 905	Electrolytic 10 μF/16V ±20% (SRA)	—	—	—	—	
C169	—	—	257 0006 943	Ceramic chip 560 pF/50V ±5%	—	—	—	—	
C170	—	—	257 0012 966	Ceramic chip 0.01 μF/50V +80, -20%	—	—	—	—	
C171	—	—	254 4254 909	Electrolytic 10 μF/16V ±20%	—	—	—	—	
C186	257 0008 983	Ceramic chip 1000 pF/50V ±10%	—	—	257 0008 983	Ceramic chip 1000 pF/50V ±10%	257 0008 983	Ceramic chip 1000 pF/50V ±10%	
C505,506	257 4537 924	Ceramic 33 pF/50V ±5%	253 1179 945	Ceramic 220 pF/50V ±10%	253 1179 945	Ceramic 220 pF/50V ±10%	253 4537 924	Ceramic 33 pF/50V ±5%	
C509,510	254 4254 938	Electrolytic 47 μF/16V ±20%	254 4254 941	Electrolytic 100 μF/16V ±20%	254 4254 938	Electrolytic 47 μF/16V ±20%	254 4254 938	Electrolytic 47 μF/16V ±20%	
C515,516	254 4260 993	Electrolytic 22 μF/50V ±20%	254 4254 938	Electrolytic 47 μF/16V ±20%	254 4260 993	Electrolytic 22 μF/50V ±20%	254 4260 993	Electrolytic 22 μF/50V ±20%	
C535 536	253 4537 924	Ceramic 33 pF/50V ±5%	253 1179 945	Ceramic 220 pF/50V ±10%	253 1179 945	Ceramic 220 pF/50V ±10%	253 4537 924	Ceramic 33 pF/50V ±5%	
C562	253 4537 924	Ceramic 33 pF/50V ±5%	253 1179 945	Ceramic 220 pF/50V ±10%	253 1179 945	Ceramic 220 pF/50V ±10%	253 4537 924	Ceramic 33 pF/50V ±5%	
D101	—	—	276 0432 903	Diode 1SS270A	—	—	—	—	
C111	—	—	262 1701 906	IC SAA6579T	—	—	—	—	
C112	—	—	262 1929 908	IC LC7074M-TE-R	—	—	—	—	
R149	—	—	247 0009 985	Carbon chip 10 kohm 1/10W ±5%	—	—	—	—	
R196	—	(Jumper)	—	(Jumper)	241 2400 924	Carbon film 5.1 kohm 1/4W ±5%	241 2400 924	Carbon film 5.1 kohm 1/4W ±5%	
R197	—	—	—	—	241 2400 995	Carbon film 10 kohm 1/4W ±5%	241 2400 995	Carbon film 10 kohm 1/4W ±5%	
R200	—	—	247 0009 985	Carbon chip 10 kohm 1/10W ±5%	—	—	—	—	
X101	—	—	399 0178 007	Crystal resonator 4.332 MHz	—	—	—	—	
X102	—	—	399 0191 903	Ceramic resonator 4.00MHz	—	—	—	—	

1U-3066 POWER AMP. UNIT

Ref. No.	U.S.A. Model		Europe Model		Asia Model		Taiwan R.O.C Model		Remarks
	Part No.	Part Name	Part No.	Part Name	Part No.	Part Name	Part No.	Part Name	
	1U-3066	Power amp. p.w.b. unit	1U-3066A	Power amp. p.w.b. unit	1U-3066A	Power amp. p.w.b. unit	1U-3066	Power amp. p.w.b. unit	
△ AC501	203 3976 002	AC outlet (2P)	—	—	—	—	203 3976 002	AC outlet (2P)	
CX23	—	—	205 0581 001	2P VH connector base	205 0581 001	2P VH connector base	—	—	
△ F1	206 1046 001	Fuse 6.3A	206 1015 032	Fuse 2.5A	206 1015 032	Fuse 2.5A	206 1046 001	Fuse 6.3A	
	—	—	513 2585 074	Fuse label	513 2585 074	Fuse label	—	—	for F1
△ F8	206 1046 014	Fuse 8A	206 1015 032	Fuse 2.5A	206 1015 032	Fuse 2.5A	206 1046 014	Fuse 8A	
	—	—	513 2585 074	Fuse label	513 2585 074	Fuse label	—	—	for F8
△ F11,12	206 1039 063	Fuse 2.0A	206 1015 061	Fuse 2A	206 1015 061	Fuse 2A	206 1039 063	Fuse 2.0A	
	—	—	513 2585 032	Fuse label	513 2585 032	Fuse label	—	—	for F11,12
JK502	204 8264 013	Head phone jack (NI)	204 8264 013	Head phone jack (NI)	204 8264 071	Head phone jack (gold)	204 8264 013	Head phone jack (NI)	
R734	242 2009 001	Composition 2.2 Mohm 1/2W ±10%	—	—	—	—	242 2009 001	Composition 2.2 Mohm 1/2W ±10%	
T501	233 6073 000	Power trans. (Mini)-EU	233 6058 009	Power trans. (Mini)-E2	233 6058 009	Power trans. (Mini)-E2	233 6073 000	Power trans. (Mini)-EU	
	—	—	415 0299 000	Condenser cover	415 0299 000	Condenser cover	—	—	or C648

ADDENDUM PARTS LIST OF EXPLODED VIEW

Ref. No.	Part Name	Part No.						
		U.S.A. /Canada Black Model	Europe Black Model	Asia Black Model	Taiwan R.O.C Black Model	Europe Gold Model	Taiwan R.O.C Gold Model	Asia Gold Model (AVR-1420)
13	Back panel	105 1260 209	105 1260 225	105 1260 225	105 1260 209	105 1260 225	105 1260 209	105 1260 238
14	Inner panel ass'y	146 2041 101	146 2041 169	146 2041 101	146 2041 101	146 2041 130	146 2041 172	146 2041 127
15	Tuning knob	113 1804 006	113 1804 006	113 1804 006	113 1804 006	113 1804 022	113 1804 019	113 1804 019
16	Function knob	113 1805 005	113 1805 005	113 1805 005	113 1805 005	113 1805 021	113 1805 018	113 1805 018
17	Tuning-2 knob	113 1823 100	113 1823 100	113 1823 100	113 1823 100	113 1823 126	113 1823 113	113 1823 113
△ 26	AC cord	206 2060 002	206 2063 009	206 2063 009	206 2060 002	206 2063 009	206 2060 002	206 2063 009
29	Power trans	233 6232 003	233 6240 008	233 6240 008	233 6232 003	233 6240 008	233 6232 003	233 6240 008
30	VR. knob ass'y	112 0744 067	112 0744 067	112 0744 067	112 0744 067	112 0744 054	112 0744 070	112 0744 070
31	Knob (MARU)	112 0685 100	112 0685 100	112 0685 100	112 0685 100	112 0685 168	112 0685 113	112 0685 113
32	Pknob (P) ass'y	113 9213 000	113 9213 000	113 9213 000	113 9213 000	113 9213 013	113 9213 039	113 9213 039
37	Top cover	102 0583 030	102 0583 030	102 0583 030	102 0583 030	102 0583 043	102 0583 043	102 0583 056
50	Side bracket	—	412 2955 107	412 2955 107	—	412 2955 107	—	412 2955 107
△ 51	AC outlet (E2)	—	203 3942 007	203 3942 007	—	203 3942 007	—	203 3942 007
52	UL tube (8.3)	—	415 0546 070	415 0546 070	—	415 0546 070	—	415 0546 070
53	Wood board (L)	—	—	—	—	—	—	101 2491 046
54	Wood board (R)	—	—	—	—	—	—	101 2492 045
55	Felt sheet	—	—	—	—	—	—	124 0032 015
56	CE label	—	513 2521 009	—	—	513 2521 009	—	—
57	Rating label (T)	—	—	—	513 2750 003	—	513 2750 003	—
58	Serial No.sheet (T)	—	—	—	513 2481 000	—	513 2481 000	—
59	Caution label (T)	—	—	—	513 2482 009	—	513 2482 009	—
60	Side pad	—	—	—	—	—	—	504 0159 013
61	5 Washer BKNI	—	—	—	—	—	—	475 1006 016
62	Screw 4X8 CBTS(B)-B-3P	473 8064 000	473 8064 000	473 8064 000	473 8064 000	—	—	—
63	Screw 4X25 CBTS (1)	—	—	—	—	—	—	473 3809 011
64	Screw 4X8 CBTS(B)-N-3P	—	—	—	—	473 8064 013	473 8064 013	—
65	Screw 3X8 CBTS (S)-B	—	473 7015 018	473 7015 018	—	473 7015 018	—	473 7015 018
66	Fixing screw	477 0064 107	—	—	477 0064 107	—	477 0064 107	—
67	Screw 3X8 CBTS (S)-B	—	—	—	—	—	—	473 7007 039
153	Cushion	503 1236 107	503 1236 107	503 1236 107	503 1236 107	503 1236 107	503 1236 107	503 1252 107
155	Instruction manual	511 3182 001	511 3205 001	511 3182 001	511 3182 001	511 3205 001	511 3182 001	511 3182 001
158	Remote controller RC-832	399 0458 002	—	399 0458 002	399 0458 002	—	399 0458 002	399 0458 002
158	Remote controller RC-833	—	399 0459 001	—	—	399 0459 001	—	—
161	Carton case	501 1988 006	501 1988 006	501 1988 006	501 1988 006	501 1988 006	501 1988 006	501 1954 085
170	KOLIN label (T)	—	—	—	513 2641 086	—	513 2641 086	—
171	Color label (gold)	—	—	—	—	513 9111 001	—	513 9111 001
172	CE label	—	513 2521 009	—	—	513 2521 009	—	—
173	Rating label (T)	—	—	—	513 2750 003	—	—	—

EXPLODED VIEW OF CHASSIS AND CABINET

1 2 3 4 5 6 7 8

WARNING:
Parts marked with this symbol  have critical characteristics.
Use **ONLY** replacement parts recommended by the manufacturer.

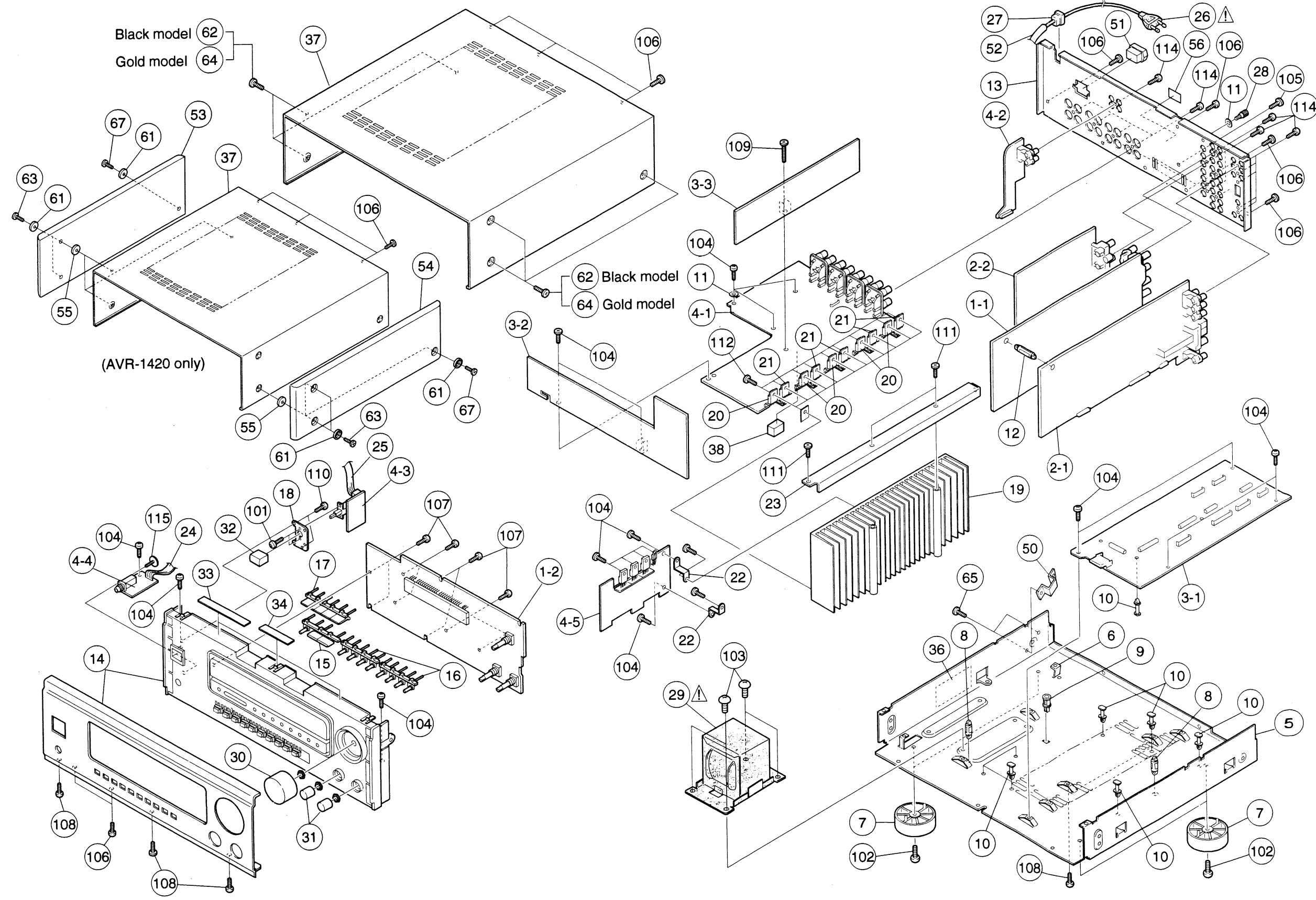

A
B
C
D
E

ADDITIONAL SEMICONDUCTORS

SAA6579T (CO: IC111)

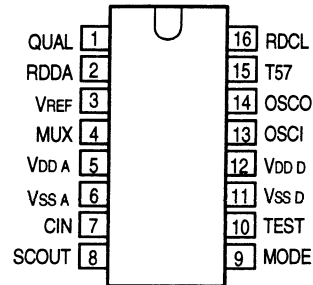
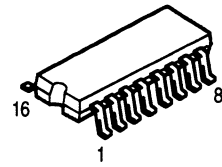

SAA6579T Terminal Function

Pin No.	Symbol	Function
1	QUAL	Quality indication output.
2	RDDA	RDS data output.
3	Vref	Reference voltage output (0.5 VDD A).
4	MUX	Multiplex signal input.
5	VDD A	+5V power supply for analog part.
6	VSS A	Ground for analog part (0V).
7	CIN	Subcarrier input to comparator.
8	SCOUT	Subcarrier output of reconstruction filter.
9	MODE	Oscillation mode/test control input.
10	TEST	Test enable input.
11	VSS D	Ground for digital part (0V).
12	VDD D	+5V power supply for digital part.
13	OSCI	Oscillator input.
14	OSCO	Oscillator output.
15	T57	57kHz clock signal output.
16	RDCL	RDS clock output.

WIRE ARRANGEMENT

In case of wires require unclasp or loosening to move the location to perform adjustment or part replacement, be sure to rearrange them neatly to restore properly in the same location as they were originally placed, or causing to produce a noise may occasionally occur.

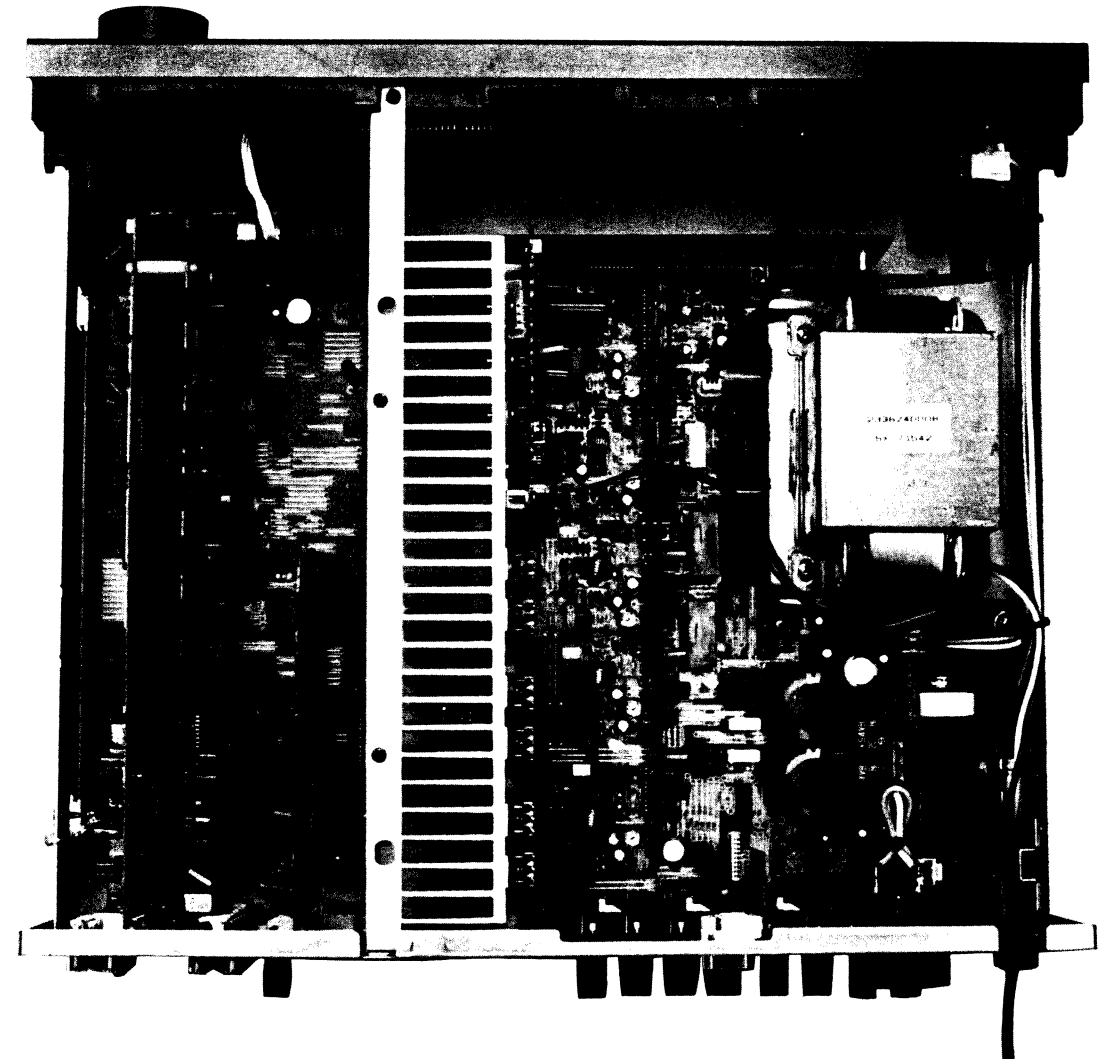

LC7074M (CO: IC112)

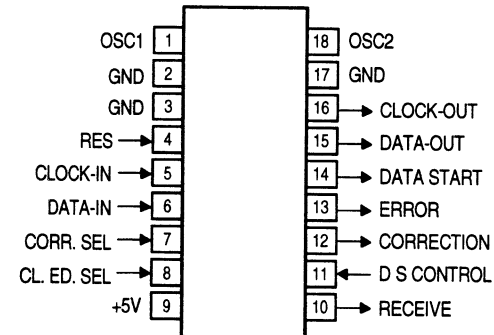
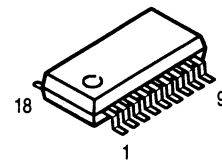

DENON

Hi-Fi AV Surround Receiver

SERVICE MANUAL MODEL AVR-1400 AV SURROUND RECEIVER

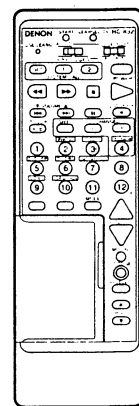
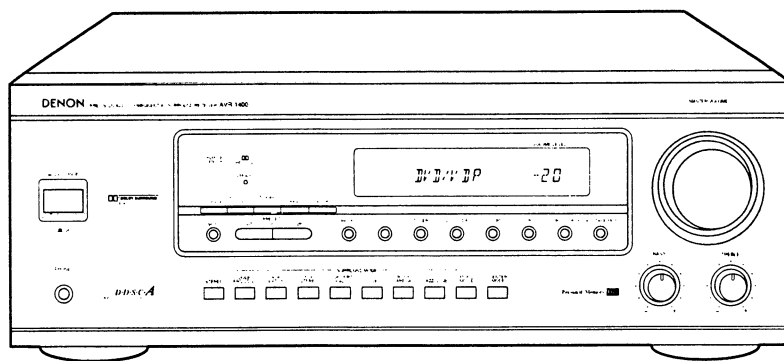

— TABLE OF CONTENTS —

OPERATING INSTRUCTIONS	2-11
SPECIFICATIONS	12
WIRE ARRANGEMENT	13
DISASSEMBLY	14
BLOCK DIAGRAM	15
BLOCK LEVEL DIAGRAM	16
ADJUSTMENT	16-18
SEMICONDUCTORS	19-30
PRINTED WIRING BOARD	31-34
NOTE FOR PARTS LIST	35
PARTS LIST OF P.W.B. UNIT ASS'Y	36-43
EXPLODED VIEW OF CHASSIS AND CABINET	44
PARTS LIST OF EXPLODED VIEW	45
WIRING DIAGRAM	46
SCHEMATIC DIAGRAM	47-56
REMOTE CONTROL UNIT (RC-832)	57, 58
SCHEMATIC DIAGRAM	57
EXPLODED VIEW	58
PARTS LIST	58

● In order to explain clearly, some illustrations using in this service manual may be slightly different from the actual set.

NIPPON COLUMBIA CO., LTD.

SAFETY INSTRUCTIONS

1. Read Instructions – All the safety and operating instructions should be read before the appliance is operated.
2. Retain Instructions – The safety and operating instructions should be retained for future reference.
3. Heed Warnings – All warnings on the appliance and in the operating instructions should be adhered to.
4. Follow Instructions – All operating and use instructions should be followed.
5. Water and Moisture – The appliance should not be used near water – for example, near a bathtub, washbowl, kitchen sink, laundry tub, in a wet basement, or near a swimming pool, and the like.
6. Carts and Stands – The appliance should be used only with a cart or stand that is recommended by the manufacturer.
- 6A. An appliance and cart combination should be moved with care. Quick stops, excessive force, and uneven surfaces may cause the appliance and cart combination to overturn.
 
7. Wall or Ceiling Mounting – The appliance should be mounted to a wall or ceiling only as recommended by the manufacturer.
8. Ventilation – The appliance should be situated so that its location or position does not interfere with its proper ventilation. For example, the appliance should not be situated on a bed, sofa, rug, or similar surface that may block the ventilation openings; or, placed in a built-in installation, such as a bookcase or cabinet that may impede the flow of air through the ventilation openings.
9. Heat – The appliance should be situated away from heat sources such as radiators, heat registers, stoves, or other appliances (including amplifiers) that produce heat.
10. Power Sources – The appliance should be connected to a power supply only of the type described in the operating instructions or as marked on the appliance.
11. Grounding or Polarization – Precautions should be taken so that the grounding or polarization means of an appliance is not defeated.
12. Power-Cord Protection – Power-supply cords should be routed so that they are not likely to be walked on or pinched by items placed upon or against them, paying particular attention to cords at plugs, convenience receptacles, and the point where they exit from the appliance.
14. Cleaning – The appliance should be cleaned only as recommended by the manufacturer.
15. Power Lines – An outdoor antenna should be located away from power lines.
16. Outdoor Antenna Grounding – If an outside antenna is connected to the receiver, be sure the antenna system is grounded so as to provide some protection against voltage surges and built-up static charges. Article 810 of the National Electrical Code, ANSI/NFPA 70, provides information with regard to proper grounding of the mast and supporting structure, grounding of the lead-in wire to an antenna-discharge unit, size of grounding conductors, location of antenna-discharge unit, connection to grounding electrodes, and requirements for the grounding electrode. See Figure A.
17. Nonuse Periods – The power cord of the appliance should be unplugged from the outlet when left unused for a long period of time.
18. Object and Liquid Entry – Care should be taken so that objects do not fall and liquids are not spilled into the enclosure through openings.
19. Damage Requiring Service – The appliance should be serviced by qualified service personnel when:
 - A. The power-supply cord or the plug has been damaged; or
 - B. Objects have fallen, or liquid has been spilled into the appliance; or
 - C. The appliance has been exposed to rain; or
 - D. The appliance does not appear to operate normally or exhibits a marked change in performance; or
 - E. The appliance has been dropped, or the enclosure damaged.
20. Servicing – The user should not attempt to service the appliance beyond that described in the operating instructions. All other servicing should be referred to qualified service personnel!

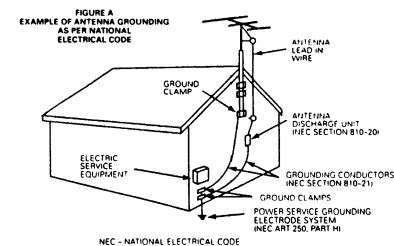

• SAFETY PRECAUTIONS

WARNING:

TO PREVENT FIRE OR SHOCK HAZARD, DO NOT EXPOSE THIS APPLIANCE TO RAIN OR MOISTURE.



CAUTION

RISK OF ELECTRIC SHOCK
DO NOT OPEN



CAUTION: TO REDUCE THE RISK OF ELECTRIC SHOCK, DO NOT REMOVE COVER (OR BACK). NO USER-SERVICEABLE PARTS INSIDE. REFER SERVICING TO QUALIFIED SERVICE PERSONNEL.



The lightning flash with arrowhead symbol, within an equilateral triangle, is intended to alert the user to the presence of uninsulated "dangerous voltage" within the product's enclosure that may be of sufficient magnitude to constitute a risk of electric shock to persons.



The exclamation point within an equilateral triangle is intended to alert the user to the presence of important operating and maintenance (servicing) instructions in the literature accompanying the appliance.

• FOR U.S.A. & CANADA MODEL ONLY

CAUTION

TO PREVENT ELECTRIC SHOCK DO NOT USE THIS (POLARIZED) PLUG WITH AN EXTENSION CORD, RECEPTACLE OR OTHER OUTLET UNLESS THE BLADES CAN BE FULLY INSERTED TO PREVENT BLADE EXPOSURE.

• POUR LES MODELE CANADIEN UNIQUEMENT

ATTENTION

POUR PREVENIR LES CHOCS ELECTRIQUES NE PAS UTILISER CETTE FICHE POLARISEE AVEC UN PROLONGATEUR UNE PRISE DE COURANT OU UNE AUTRE SORTIE DE COURANT, SAUF SI LES LAMES PEUVENT ETRE INSEREES A FOND SANS EN LAISSER AUCUNE PARTIE A DECOUVERT.

• 安全事項

警告：

為防着火或觸電，切勿讓本機遭雨淋濕或受潮。



CAUTION

RISK OF ELECTRIC SHOCK
DO NOT OPEN



注意：為減少觸電危險，切勿折下機殼（或機背）。機身內並無用戶修理用零件。請交由專業修理人員修理本機。



三角形內有箭頭的閃電符號旨在提醒用戶，本產品機殼內有未經絕緣的“危險電壓”，其幅度足以使人觸電而發生危險。



三角形內加感嘆號旨在提醒用戶，有重要的操作與維修說明書配合本機。

“SERIAL NO. _____

PLEASE RECORD UNIT SERIAL NUMBER ATTACHED TO THE REAR OF THE CABINET FOR FUTURE REFERENCE”

“NO. DE SERIE _____

PRIERE DE NOTER LE NUMERO DE SERIE DE L'APPAREIL INSCRIT A L'ARRIERE DU COFFRET DE FAÇON A POUVOIR LE CONSULTER EN CAS DE PROBLEME.”

“序號 _____

請將來機背後所附序號記錄下來，以作參考之用。”

TABLE OF CONTENTS

1 Note on Use	5	8 Using the Surround Function	16-18
2 Before Using	5	9 Listening to the Radio	19, 20
3 Cautions on Installation	5	10 Last Function Memory	20
4 Cautions on Handling	5	11 Initialization of the Microprocessor	20
5 Connections	6-8	12 Troubleshooting	21
6 Remote Control Unit	9-12	13 Specifications	22
7 Operations	13-15		

TABLE DES MATIERES

1 Observations Relatives à L'utilisation	23	8 Utilisation de la Fonction D'ambiance	34-36
2 Avant Utilisation	23	9 Écouter la Radio	37, 38
3 Précautions D'installation	23	10 Mémoire de Dernière Fonction	38
4 Précautions de Manipulation	23	11 Initialisation du Microprocesseur	38
5 Connexions	24-26	12 Dépistage des Pannes	39
6 Télécommande	27-30	13 Spécifications	40
7 Fonctionnement	31-33		

目錄

1 使用注意事項	41	8 使用環迴聲功能	52-54
2 使用前須知	41	9 收聽電台廣播	55, 56
3 安裝注意事項	41	10 維持功能記憶	56
4 處理注意事項	41	11 微處理器的初始化	56
5 聯接方法	42-44	12 故障診斷	57
6 遙控器	45-48	13 規格	58
7 操作說明	49-51		

ACCESSORIES

Check that the following parts are included in addition to the main unit:

① Operating instructions	1	② Warranty (for North American model only)	1	③ Service station list	1
④ Remote control unit (RC-832)	1	⑤ R6P/AA batteries	2	⑥ AM loop antenna	1
		⑦ FM indoor antenna	1	⑧ FM antenna adaptor	1

ACCESSOIRES

Vérifier que les articles suivants sont inclus dans le carton en plus de l'unité principale:

① Mode d'emploi	1	② Certificat de garantie (pour l'Amérique du Nord uniquement)	1	③ Liste des centres d'entretien	1
④ Télécommande (RC-832)	1	⑤ Piles R6P/AA	2	⑥ Antenne-cadre AM	1
		⑦ Antenne intérieure FM	1	⑧ Adaptateur d'antenne FM	1

配件

除主機外，另附下列物品，請查檢：

1 操作說明書	2 保用証 (只限北美機型)	3 維修站一覽表	1 遙控器
4 遙控器 (RC-832)	5 R6P/AA電池	6 AM環形天線	7 FM室內天線
	8 AM環形天線	9 FM室內天線	10 FM天線轉接器

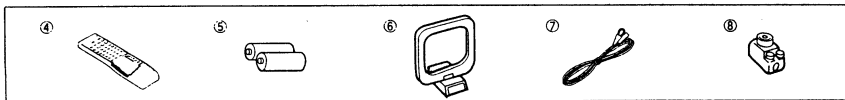

1 NOTE ON USE

<ul style="list-style-type: none"> Avoid high temperatures. Allow for sufficient heat dispersion when installed on a rack. 	<ul style="list-style-type: none"> Keep the set free from moisture, water, and dust. 	<ul style="list-style-type: none"> Do not let foreign objects in the set.
<ul style="list-style-type: none"> Unplug the power cord when not using the set for long periods of time. 	<ul style="list-style-type: none"> Do not let insecticides, benzene, and thinner come in contact with the set. 	
<ul style="list-style-type: none"> Handle the power cord carefully. Hold the plug when unplugging the cord. 	<ul style="list-style-type: none"> Do not obstruct the ventilation holes. 	<ul style="list-style-type: none"> Never disassemble or modify the set in any way.

* (For sets with ventilation holes)

2 BEFORE USING

Pay attention to the following before using this unit:

- Moving the set**
To prevent short circuits or damaged wires in the connection cords, always unplug the power cord and disconnect the connection cords between all other audio components when moving the set.
- Before turning the power operation switch on**
Check once again that all connections are proper and that there are not problems with the connection cords. Always set the power operation switch to the standby position before connecting and disconnecting connection cords.
- Store this instructions in a safe place.**
After reading, store this instructions along with the warranty in a safe place. Also fill in the items on the back page for your convenience.
- Note that the illustrations in this instructions may differ from the actual set for explanation purposes.**

4 CAUTIONS ON HANDLING

- Switching the input function when input jacks are not connected**
A clicking noise may be produced if the input function is switched when nothing is connected to the input jacks. If this happens, either turn down the MASTER VOLUME control or connect components to the input jacks.
- Muting of PRE OUT jacks**
The PRE OUT jacks include a muting circuit. Because of this, the output signals are greatly reduced for several seconds after the power operation switch is turned on or input function, surround mode or any other set-up is changed. If the volume is turned up during this time, the output will be very high after the muting circuit stops functioning. Always wait until the muting circuit turns off before adjusting the volume.
- Whenever the POWER operation switch is in the OFF state (see page 13), the apparatus is still connected on some AC line voltages.**
Please be sure to unplug the cord when you leave home for, say, a vacation.

3 CAUTIONS ON INSTALLATION

Noise or disturbance of the picture may be generated if this unit or any other electronic equipment using microprocessors is used near a tuner or TV.

If this happens, take the following steps:

- Install this unit as far as possible from the tuner or TV.
- Set the antenna wires from the tuner or TV away from this unit's power cord and input/output connection cords.
- Noise or disturbance tends to occur particularly when using indoor antennas or 300 Ω/ohms feeder wires. **We recommend using outdoor antennas and 75 Ω/ohms coaxial cables.**

For heat dispersal, leave at least 10 cm of space between the top, back and sides of this unit and the wall or other components.

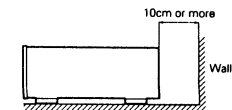
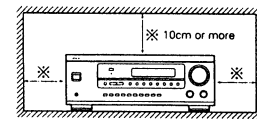

5 CONNECTIONS

- Do not plug in the power cord until all connections have been completed.
- Be sure to connect the left and right channels properly (left with left, right with right).
- Insert the plugs securely. Incomplete connections will result in the generation of noise.
- Use the AC OUTLETS for audio equipment only. Do not use them for hair driers, etc.
- Note that binding pin plug cords together with power cords or placing them near a power transformer will result in generating hum or other noise.
- Noise or humming may be generated if a connected audio equipment is used independently without turning the power of this unit on. If this happens, turn on the power of the this unit.

Connecting the audio components

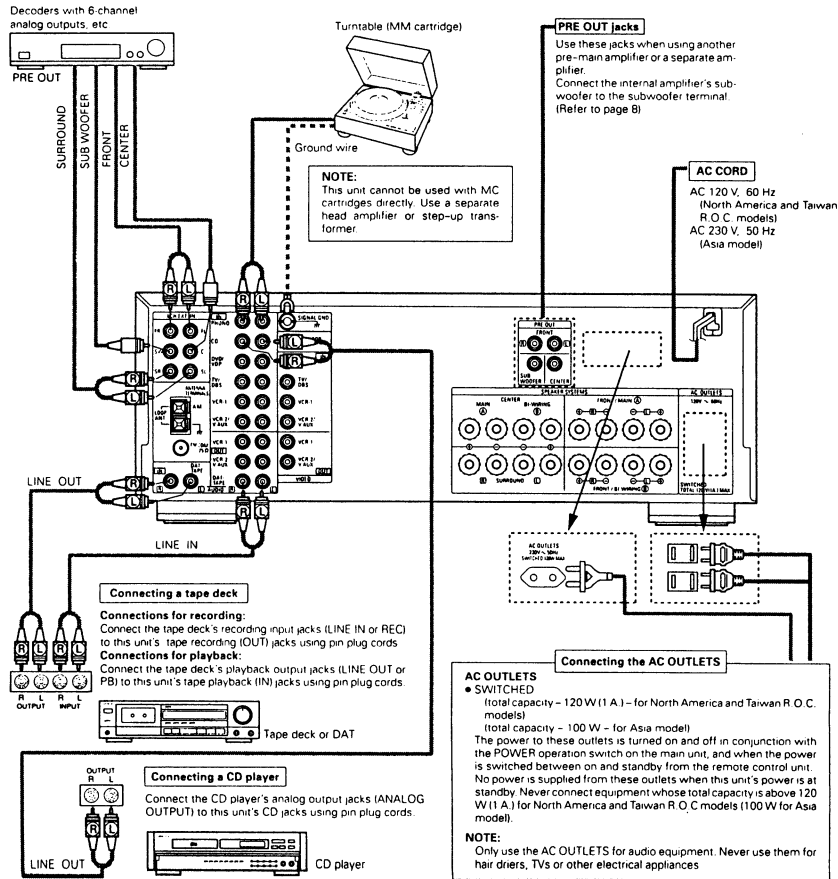

Connecting the video equipments

To connect the video signal, connect using a 75 Ω/ohms video signal cable cord. Using an improper cable can result in a drop in video quality.

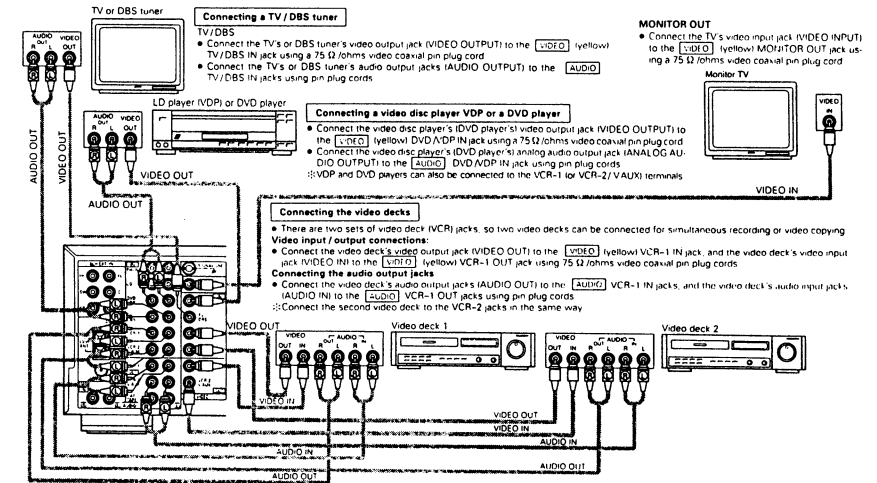

Connecting the antenna terminals

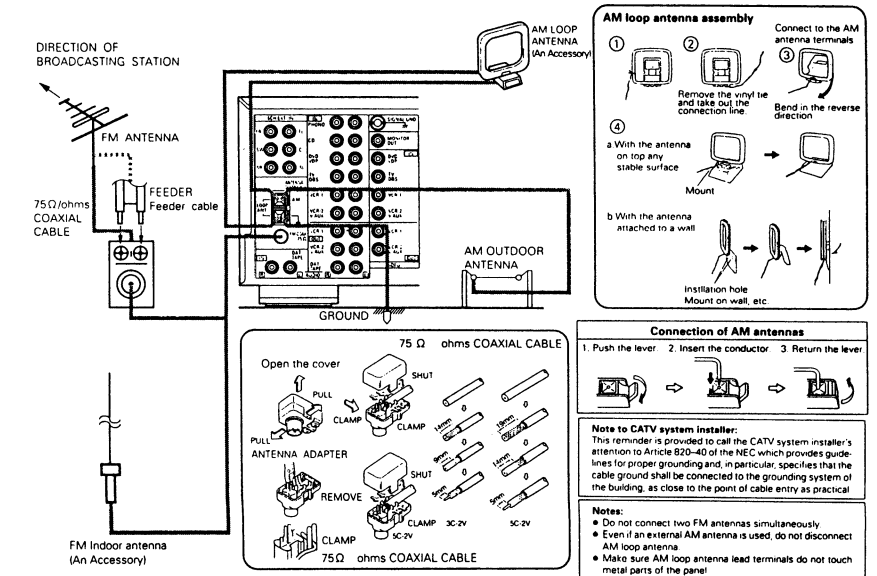

Speaker system connections

- Connect the speaker terminals with the speakers making sure that like polarities are matched (⊕ with ⊕, ⊖ with ⊖). Mismatching of polarities will result in weak central sound, unclear orientation of the various instruments, and the sense of direction of the stereo being impaired.
- When making connections, take care that none of the individual conductors of the speaker cord come in contact with adjacent terminals, with other speaker cord conductors, or with the rear panel. Use banana plugs the speaker cords touch or if their core wire is thick and it is difficult to connect the cord to the speaker terminal. (In this case as well, pay attention to the treatment of the conductor sticking out of the banana plug.)
(for North America and Taiwan R.O.C. models only.)

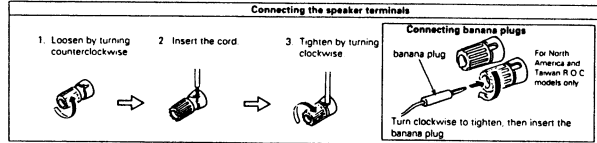

Precautions when connecting speakers
If a speaker is placed near a TV or video monitor, the colors on the screen may be disturbed by the speaker's magnetism. If this should happen, move the speaker away to a position where it does not have this effect.

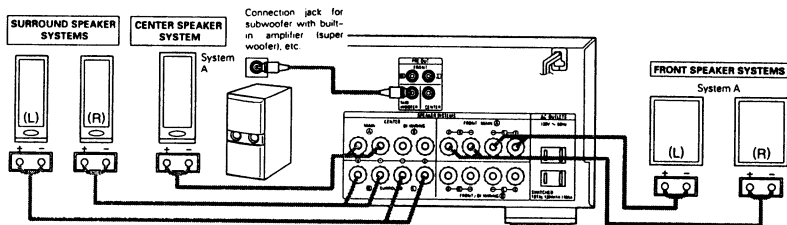

- About bi-wiring
If your speakers have bi-wiring terminals, you can achieve higher quality sound by adding cords and using bi-wiring, as shown on the diagram below.
- By connecting speaker systems to both the speaker A and B terminals, you can play the same music source simultaneously in different rooms. (Use speakers with impedances of 12 Ω/ohms.)

Bi-wiring procedure

SPEAKER SYSTEM (BI-WIRING)

When bi-wiring with bi-wireable speakers, connect the mid and high range terminals to SYSTEM (A) [or SYSTEM (B)], the low range terminals to SYSTEM (B) [or SYSTEM (A)].

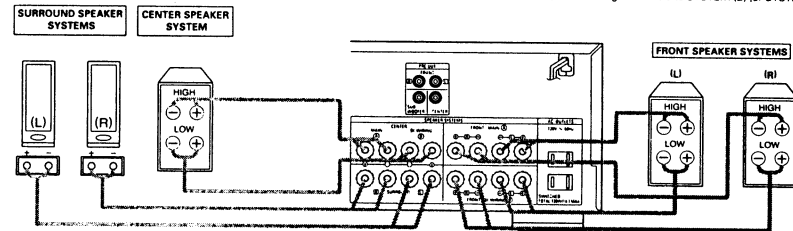

Protector circuit

This set has a built-in high speed protector circuit which protects the internal circuitry from strong currents that may be generated if the speakers are used with their cords insecurely connected to the speaker terminals or if the cords are short-circuited, and when the internal temperature becomes abnormally high due to blocked ventilation holes or continuous high power conditions while using speakers other than the specified ones.

If this protector circuit is activated, the speaker output is automatically cut off, the display turns off and the STANDBY LED flashes rapidly. If this should happen, be sure to turn off the set's power, then check the speaker cord connections, remove the object blocking the ventilation holes, or replace the speakers with speakers with impedances within the specified range before turning the power back on. The sound will be muted for several seconds, after which the set will operate normally.

Speaker Impedance

- When speaker systems A and B are used separately, speakers with an impedance of from 6 to 16 Ω/ohms can be connected for use as front and center speakers.
- Be careful when using two pairs of front or center speakers (A + B) at the same time, since use of speakers with an impedance of less than 12 Ω/ohms will lead to damage.
- Speakers with an impedance of 6 to 16 Ω/ohms can be connected for use as surround speakers.
- The protection circuit may operate or damage may occur when speakers with an impedance outside of the above range are used.

6 REMOTE CONTROL UNIT

Following the procedure outlined below, insert the batteries before using the remote control unit.

Range of operation of the remote control unit

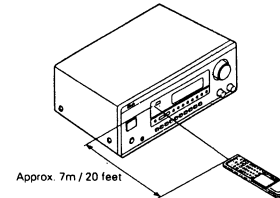

Point the remote control unit at the remote control sensor as shown on the diagram at the left.

NOTES:

- The remote control unit can be used from a straight distance of approximately 7 meters/20 feet, but this distance will shorten or operation will become difficult if there are obstacles between the remote control unit and the remote control sensor, if the remote control sensor is exposed to direct sunlight or other strong light, or if operated from an angle.
- Neon signs or other devices emitting pulse-type noise nearby may result in malfunction, so keep the set as far away from such devices as possible.

Inserting the batteries

- Press as shown by the arrow and slide off.
- Insert the SUM3 batteries properly, as shown on the diagram.
- Close the lid.

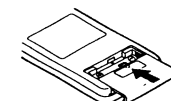
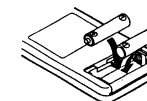
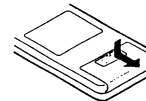

NOTES:

- Use only AA, R6P, UM-3 batteries for replacement.
- Be sure the polarities are correct. (See the illustration inside the battery compartment.)
- Remove the batteries if the remote control transmitter will not be used for an extended period of time.
- If batteries leak, dispose of them immediately. Avoid touching the leaked material or letting it come in contact with clothing, etc. Clean the battery compartment thoroughly before installing new batteries.
- Have replacement batteries on hand so that the old batteries can be replaced as quickly as possible when the time comes.
- The codes that have been learned may be lost if removed batteries are not replaced within about 5 minutes.

System code buttons

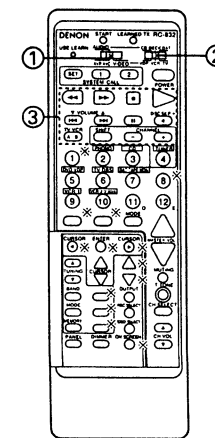

DENON remote-controllable audio components can be controlled using this unit's remote control unit. Note that some components, however, cannot be operated with this remote control unit.

- Set to slide switch to "AUDIO" ("AVR/AVC").
- Set the slide switch to the position for the component to be operated (CD, DECK or DAT).



- Use the buttons shown below to operate the audio component. For details, refer to the respective component's manual.

a. For CD players and DATs

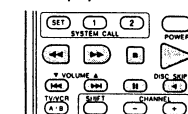

- Manual search (reverse and forward)
- Stop
- Play
- Auto search
- Pause
- DISC : Disc selection
- SKIP+ : (CD changer only)

b. For tape decks (DECK)

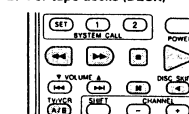

- Reverse
- Forward
- Stop
- Forward play
- Pause
- A/B : A/B deck selection
- Reverse play

* These buttons does not function.
(Some buttons can be used by using the pre-set memory or the learning function.)

Preset memory

DENON and other makes of components can be operated by setting the preset memory for your make of video component. **Operation is not possible for some models, however. In this case use the learning function (see page 11) to store the remote control signals.** For instructions on clearing the presettings stored in the preset memory, see page 12.

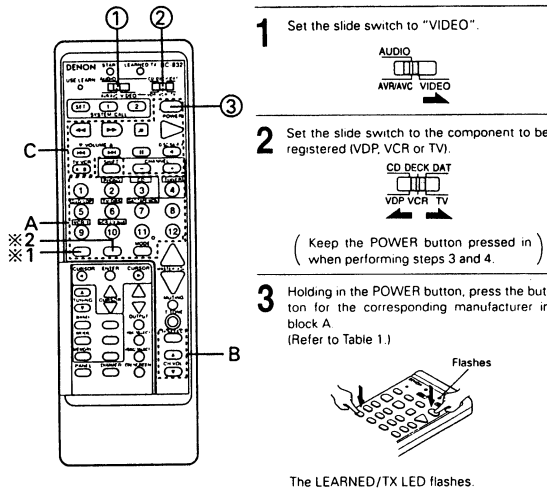

- 1 Set the slide switch to "VIDEO".
- 2 Set the slide switch to the component to be registered (VDP, VCR or TV).
(Keep the POWER button pressed in when performing steps 3 and 4.)
- 3 Holding in the POWER button, press the button for the corresponding manufacturer in block A (Refer to Table 1.)
- 4 Next, while holding in the POWER button, press the button for the code in block B. (Refer to Table 1.) The operation is completed when the LEARNED/TX LED lights.
- 5 To continue registering other components, repeat steps 2 to 4.

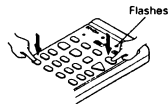

The LEARNED/TX LED flashes.

This remote control unit can be used to operate components of other manufacturers without using the learning function by registering the manufacturer of the component as shown on Table 1.

Table 1: Combinations of Personal System Codes for Different Manufacturers

"VDP"				"VCR"				"TV"			
A	B	Code	Code	A	B	Code	Code	A	B	Code	Code
①		DENON A	DENON B	①				①			
②	(PHONO)	DENON (DVD)		②	(PHONO)	HITACHI A	HITACHI B	②	(PHONO)	DENON/HITACHI	
③	(CD)	MITSUBISHI		③	(CD)	MITSUBISHI A	MITSUBISHI B	③	(CD)	MITSUBISHI A	MITSUBISHI B
④	(TUNER)	PANASONIC		④	(TUNER)	PANASONIC A	PANASONIC B	④	(TUNER)	PANASONIC A	PANASONIC B
⑤	(DVD/VDP)			⑤	(DVD/VDP)	JVC (VCR) A	JVC (VCR) B	⑤	(DVD/VDP)	JVC (VCR) A	
⑥	(TV/DBS)	SONY A	SONY B	⑥	(TV/DBS)	SONY A	SONY B	⑥	(TV/DBS)	SONY	
⑦	(DAT TAPE MON)	PIONEER		⑦	(DAT TAPE MON)	PIONEER		⑦	(DAT TAPE MON)	PIONEER	
⑧				⑧		TOSHIBA A	TOSHIBA B	⑧		TOSHIBA A	
⑨	(VCR-1)			⑨	(VCR-1)	SANYO A	SANYO B	⑨	(VCR-1)	SANYO A	
⑩	(VCR-2/VAUX)			⑩	(VCR-2/VAUX)	SHARP A	SHARP B	⑩	(VCR-2/VAUX)	SHARP	
⑪	/0			⑪	/0	NEC A	NEC B	⑪	/0	NEC A	
⑫	/E	PHILIPS		⑫	/E	PHILIPS A	PHILIPS B	⑫	/E	PHILIPS A	
※1	○	RCA		※1	○	RCA A	RCA B	※1	○	RCA A	
※2	○			※2	○	GENERAL ELECTRIC A	GENERAL ELECTRIC B	※2	○	GENERAL ELECTRIC A	GENERAL ELECTRIC B
⑬	○	MAGNAVOX		⑬	○	MAGNAVOX A	MAGNAVOX B	⑬	○	MAGNAVOX A	

NOTES:

- The signals for the pressed buttons are emitted while setting the preset memory. To avoid accidental operation, cover the remote control unit's transmitting window while setting the preset memory.
- Some models and years of manufacture of components of the manufacturers listed on Table 1 cannot be used.

Operation after components are registered

- 1 Set the slide switch to "VIDEO".
- 2 Set the slide switch to the component to be registered (VDP, VCR or TV).

- 3 Use the buttons shown below to operate the video component. (Some models cannot be used) For details, refer to the respective component's manual.
 - a. VDP
 - POWER : Power on/off
 - Manual search (reverse and forward)
 - Stop
 - Play
 - Auto search
 - Pause
 - b. VCR
 - POWER : Power on/off
 - Manual search (reverse and forward)
 - Stop
 - Play
 - Pause
 - Channel selection
 - c. TV
 - POWER : Power on/off
 - VOLUME : Volume up/down
 - TV/VCR : TV/video selection
 - CHANNEL : Channel selection

Remote control unit learning function

If your AV components are not DENON products or if operation is not possible with the preset memory settings, the components' remote control signals can be "learned" to enable remote control operation. The buttons that can be "learned" are the CD, DAT and DECK system buttons (see page 9) and the VDP, VCR and TV system buttons (see page 11). (For the TV only, the A block buttons can also be "learned".)

- 1 Press the USE/LEARN selector button with the tip of a pen etc., to set the learn mode. Both the START and LEARNED/TX indicators flash.
- 2 Set the program switch to the side to be "learned". Set to the AUDIO side for the CD, tape deck or DAT position, to the VIDEO side for the VDP, VCR or TV position.
- 3 Set the program switch to the position to be "learned".

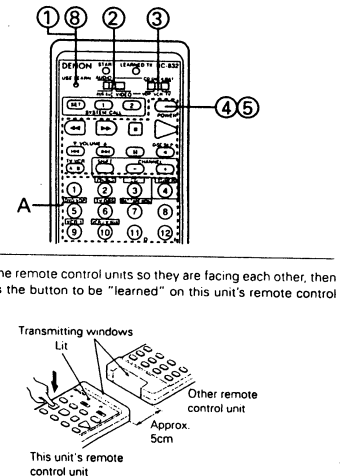

The indicator stops flashing and the START LED lights. The learnable buttons are the buttons which can be operated with the DENON system codes for the CD player, DAT and tape deck, the buttons which can be operated with the preset memory for the VCR, VDP and TV. For the TV only, however, the buttons in the section indicated "A" on the diagram above can also be "learned". Use these to "learn" TV channels.

NOTE: Use button ① / 0 as the 0 number button, button ⑦ / E as the enter button.

- 5 Check that the START LED is lit, then press the button to be "learned" on the other remote control unit.

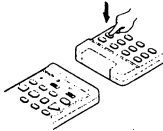

- 6 Once the START LED turns off and the LEARNED/TX LED lights, release the button on the other remote control unit.

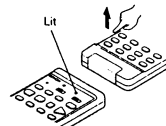

The two LEDs start flashing again.

- 7 To "learn" other buttons, repeat steps 2 to 6.

- 8 Once the learning operation is completed, press the USE/LEARN selector button again. The two LEDs stop flashing and the learning mode is cancelled.

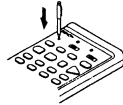

Check that the stored codes work properly.

NOTES:

- Up to 26 codes can be "learned", but this number may be lower if the codes are long
- If a non-learnable button is pressed or two or more buttons are pressed at once, the two LEDs will once again light when the button(s) is released.
- If the codes could not be stored, the LEARNED/TX LED does not light after the START LED turns off. For limited number of models, codes cannot be stored in RC-832.
- If the two LEDs start flashing rapidly after the START LED lights, this means that the memory is already full, and the code you have just attempted to store was not stored. To "learn" that code, first perform the resetting operation.

Clearing "learned" remote control signals and the preset memory settings

- 1 Press the USE/LEARN selector button with the tip of a pen, etc., to set the learn mode.

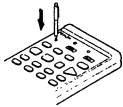

- 2 To clear "learned" remote control signals, set the slide switch to the position at which the signals were "learned". To clear the preset memory settings, set the slide switch to "VIDEO".



- 3 Set the slide switch to the position at which the signals were "learned" or at which the preset memory settings were set.

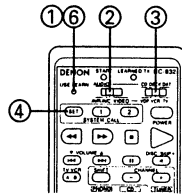

- 4 Press the SYSTEM CALL SET button, and hold it in for at least four seconds.

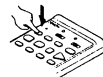

- 5 When both the START and LEARNED / TX LEDs light simultaneously, all the stored codes are cleared.

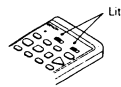

- 6 Press the USE/LEARN selector button.

7 OPERATIONS

Preparations for playback

Preparations:

Check that all connections are proper.

- 1 Set to the center position.

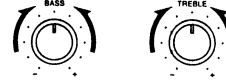

- 2 Set the remote control unit's slide switch to the AUDIO position (only when operating with the remote control unit)



- 3 Turn on the power. Press the POWER operation switch (button).



- **ON/STANDBY**
The power turns on and "STANDBY" indicator is lit. Several seconds are required from the time the POWER operation switch is set to the "ON/STANDBY" position until sound is output. This is due to the built-in muting circuit that prevents noise when the POWER operation switch is turned on and off.
- **OFF**
The power turns off and "STANDBY" indicator is off. In this position, the power cannot be turned on and off from the remote control unit.

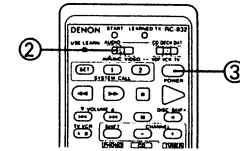
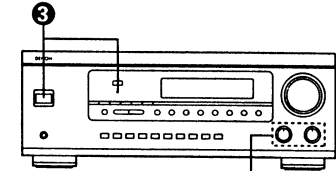

Set the POWER operation switch to this position to turn the power on and off from the included remote control unit (RC-832).

Playing the program source (Stereo playback)

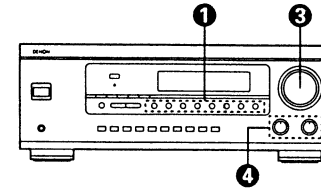

- 2 Start playback on the selected component. For operating instructions, refer to the various components' manuals.

- 3 Adjust the MASTER VOLUME control.

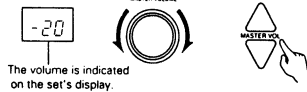

The volume is indicated on the set's display.

- The volume can be adjusted in units of 1 dB from -60 to 0 to +18 dB.

- 4 Adjust the BASS and TREBLE.



Turn the control clockwise to increase the bass or treble, counterclockwise to decrease it.

NOTE: The tone controls only affect the pre-out output and speaker output of the front left and front right channels.

- 1 Press the button for the program source to be played.
EX 1: CD



EX 2: DAT / TAPE
DAT/TAPE MON



- Press the button once to switch the source to DAT/TAPE input, again to cancel DAT/TAPE input.

Simulcast playback

Use this switch to monitor a video source other than the audio source.

- 1 Press the VIDEO SELECT button repeatedly until the desired source appears on the display.



The video source switches as follows each time the button is pressed:

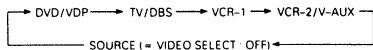

- * Cancelling simulcast playback
- Select "SOURCE" using the video select button.
- Switch the program source to the component connected to the video.

Using the muting function

Use this to turn off the audio output temporarily.

- 1 Press the MUTING button.
 - * Cancelling MUTING mode. Press the MUTING button again.



- * **Caution:** Switching off the power of the unit and the remote control unit will cancel the settings.

Listen with headphones

- 1 Connect the headphones to the PHONES jack of the front panel.



- 2 Press the OUTPUT button to play the sound over the headphones only.



- The output to the speaker and pre-out jacks is turned off and no sound is produced from the speakers.

- * **Caution:** Switching off the power of the unit and the remote control unit will cancel the settings.

Front panel display

When an operation is performed on the main unit or on the remote control unit, that operation appears on the display, making it possible to check the operation visually. The set's operating status can also be checked on the display using the procedure described below.

- 1 Press the PANEL button.

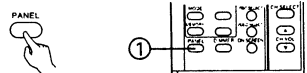

The input and output sources and the surround setting, etc., appear in order on the display each time the button is pressed.

Using the dimmer function

Use this function to adjust the brightness of the main unit's display.

- 1 Press the DIMMER button.

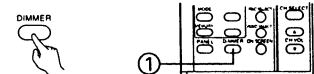

The brightness changes in the following order each time the button is pressed:

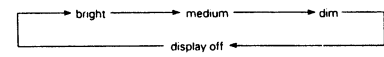

Recording the program source (recording the source currently being monitored)

- 1 Follow steps 1 to 3 under "Playing the program source".
- 2 Start recording on the tape or video deck. For instructions, refer to the component's operating instructions.

Simultaneous recording

The signals of the source selected with the function selector button are output simultaneously to the DAT/TAPE and VCR 1 and 2 REC OUT jacks. If a total of three tape and/or video decks are connected and set to the recording mode, the same source can be recorded simultaneously on every decks. In addition, if the TAPE MONITOR (DAT/TAPE) button is pressed, the audio signals from the tape deck are output to the VCR 1 and 2 AUDIO REC OUT jacks.

System call (remote control unit)

This function allows you to preset frequently used operation patterns in the remote control unit then automatically send a series of up to ten remote control codes with a single button.

- 1 **Presetting**
Press the SET button.



- 3 Press the SYSTEM CALL button ("1" or "2") at which you want to store the codes. The setting is now stored.

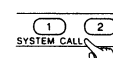

- 2 Press the buttons for the codes to be sent, changing the position of the slide switch as necessary. (Up to ten buttons can be set.) Buttons which have been "learned" and buttons which have been preset can also be selected.

- 4 **Recalling**
Press the SYSTEM CALL button ("1" or "2") at which the desired codes have been stored. The series of codes is now sent.

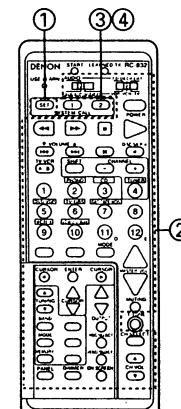
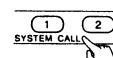

8 USING THE SURROUND FUNCTION

This unit is equipped with signal processing sections for decoding and reproducing movie soundtracks the same way as in movie theaters.

Before playing with the surround function

Before playing with the surround function, be sure to use the test tones to adjust the playback level from the different speakers. This adjustment can be performed from the remote control unit, as described below. Adjusting with the remote control unit using the test tones is only effective in the DOLBY PRO LOGIC mode. The adjusted levels are automatically stored in the memory.

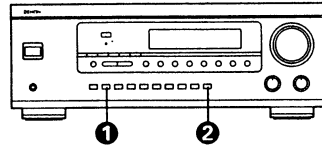

1 Set the Dolby Pro Logic mode.

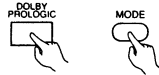

2 Select the center mode.

(Refer to the description of the center mode below.)
Select the center mode according to the center speaker.

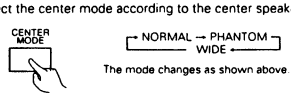

3 Press the test tone button.

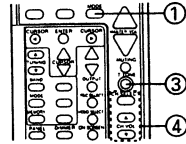

4 Test tones are produced from the speakers in the order shown below, at 4 second intervals for the first two cycles, 2 second intervals after that.



Use the channel volume adjust buttons to adjust so that the volume of the test tones is the same for all the speakers.

Press the channel select button to select the speaker to be adjusted, if necessary.



5 After completing the adjustment, press the test tone button again.



NOTES:

- When the center mode is set to Phantom, no test tones are output from the center speaker.
- When the center mode switch is pressed, the surround mode automatically switches to the DOLBY PRO LOGIC mode.

After adjusting using the test tones, adjust the channel levels either according to the playback sources or to suit your tastes, as described below.

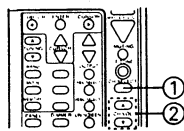

1 Press the channel select button to select the speaker to be adjusted.



2 Adjust the level of the selected speaker.



Center Mode

Set the center mode as described below, according to the type of center speaker being used.

- **Normal mode:** This mode is suited for an arrangement in which the center channel speaker is smaller than the left and right speakers. Signals below 100 Hz which have almost no effect on directional orientation are distributed to the left and right channels, whereas the center channel output signals greater than 100 Hz. As a result, the bass of the left and right channels increases the apparent deepness of the sound.
- **Phantom mode:** Use this mode when center channel speaker is not used. A directional emphasis circuit provides signal reproduction which is electrically oriented to the center and this provides an exciting sound field for your enjoyment.
- **Wide mode:** This mode is suited for an arrangement in which the center channel speaker is of the same grade as the left and right speakers. The entire sound band from low region to high is output to the center channel to provide an exciting sound field for your enjoyment.

NOTES:

- The center mode applies to the DOLBY PRO LOGIC mode.
- The output from the center speaker is turned off if the center mode is set to the phantom mode in any surround mode other than Dolby Pro Logic.
- If a center speaker is added to the system afterwards or if the center speaker is changed, be sure to reset the center mode as described above.

Using the Dolby Pro Logic mode

DOLBY PRO LOGIC

When using conventional video tapes, laserdiscs, TV programs or CDs with the mark, Dolby Pro Logic provides extremely natural sound movement and positioning, immersing you in the on-screen action. Pro Logic uses a directional emphasis circuit to decode four output channels (front left and right, center and surround) from the two audio channels provided on the software.

This set is equipped with three Dolby Pro Logic play modes: Normal, Phantom and Wide.

Play a pre-recorded source with the mark.

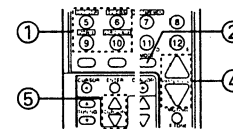
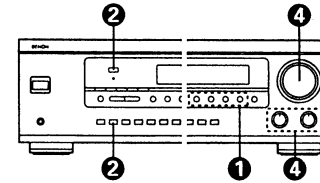

1 Press the button for the program source to be played.

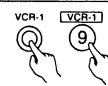

DELAY TIME

The optimum delay time will differ depending on the listening position. Referring to the chart below, set the optimum delay time for your room's space and seating position. For example, when the distance from the front speakers to the listening position is 20 feet and that from the surround speakers to the listening position is 15 feet, the optimum delay time will be 20 ms. The variable range of the delay time differs depending on the mode.

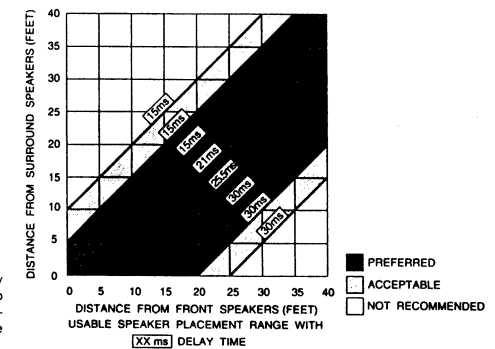
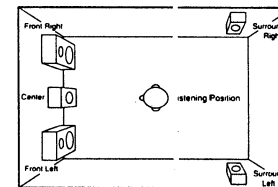

Dolby Surround systems with Pro Logic decoding most closely replicate the Dolby Stereo theatrical experience. Only two surround speakers are necessary in the home listening environment to provide the same enveloping sound field as multiple surround speakers in the theater.

Manufactured under license from Dolby Laboratories Licensing Corporation. DOLBY, the double-D symbol and "PRO LOGIC," are trademarks of Dolby Laboratories Licensing Corporation.

Surround simulation

Types of surround modes and their characteristics

1	STEREO	Sound is produced from the two front channels. (Nothing is output from the Surround and center channels.)
2	6CH EXT. IN	Connect the output of the external Dolby Digital decoder to this unit's 6CH EXT. IN.
3	SCH STEREO	The signals of the left and right channels are distributed to the different speakers to achieve a stereo sound from all directions at the listening position.
4	CONCERT HALL	Use this setting to create the atmosphere of a concert hall.
5	LIVE	Use this setting to create the atmosphere of watching a live performance.
6	ROCK ARENA	The powerful reverberations of this mode produce a sound field which recreates the excitement of live concerts. This mode is effective for rock, popular music, etc.
7	JAZZ CLUB	This mode creates the sound field of a live house with a low ceiling and hard wall reverberations. The result is that the artist seems to be performing right before your eyes.
8	MONO MOVIE	In this mode, a sense of expansion is added to monaural audio sources. This mode is best suited for playing old movies or movie tapes recorded in monaural.

※ Depending on the program source being played, the effect may not be very noticeable. In this case, try other surround modes, without worrying about their names, to create a sound field suited to your tastes.

Personal Memory Plus function for EASY USE

This unit automatically stores the surround mode adding selected effects for all input sources. The corresponding surround mode is recalled automatically each time an input source is selected.

Using the surround simulation

Preparations: Select the input device and start playback.

1 Select the surround mode according to the input source.

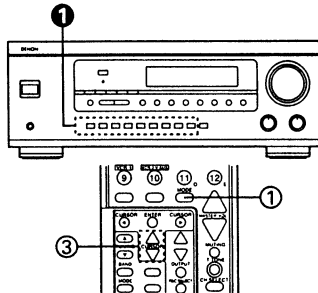
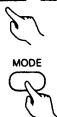

2 If necessary, adjust the levels. Refer to page 16.

3 Adjust the DELAY TIME to the desired settings.



NOTES:

- To listen to the signal of equipment that is connected to the "6CH EXT. IN" input jack, make sure the video input of the equipment is selecting the connected function and select "6CH EXT. IN" with the "6CH EXT. IN" mode button or with the remote control mode button.

Surround modes and parameters

MODE	The following table shows the presence or absence of signals in the various modes, and whether or not they can be controlled. Initial settings are indicated in parentheses.				PARAMETER SOURCE		
	FRONT L/R	CENTER	SURROUND	SUBWOOFER	CENTER MODE	TEST TONE	DELAY TIME
STEREO	○	○	○	○	○	○	15 - 30 msec (20 msec / step)
DOLBY PROLOGIC	○	○	○	○	○	○	
6CH EXT. IN	○	○	○	○	○	○	0 - 33 msec (21 msec) 3 msec / step
SCH STEREO	○	○	○	○	○	○	
CONCERT HALL	○	○	○	○	○	○	0 - 33 msec (21 msec) 3 msec / step
LIVE	○	○	○	○	○	○	
ROCK ARENA	○	○	○	○	○	○	0 - 33 msec (21 msec) 3 msec / step
JAZZ CLUB	○	○	○	○	○	○	
MONO MOVIE	○	○	○	○	○	○	

○ : Signal present or controllable.

○ : Can be turned on and off according to the center mode setting.
 × : No signal or not controllable.

9 LISTENING TO THE RADIO

Auto preset memory

This unit is equipped with a function for automatically searching for FM broadcast stations and storing them in the preset memory.

1 Switch on the unit using the main unit's Power operation switch while holding in the MEMORY button. The unit automatically begins searching for FM broadcast stations.



2 When the first FM broadcast station is found, that station is stored in the preset memory at channel A1. Subsequent stations are automatically stored in order at preset channels A2 to A8, B1 to B8, C1 to C8, D1 to D8 and E1 to E8, for a maximum of 40 stations.

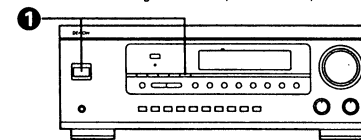

3 Channel A1 is tuned in after the auto preset memory operation is completed.

NOTES:

- If an FM station cannot be preset automatically due to poor reception, use the "Manual tuning" operation to tune in the station, then preset it using the manual "Preset memory" operation.
- To interrupt this function, press the POWER operation button.

Auto tuning

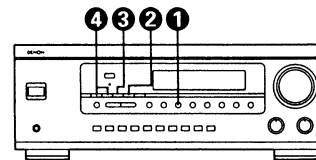

2 Watching the display, press the BAND button to select the desired band (AM or FM).



3 Press the MODE button to set the auto tuning mode.

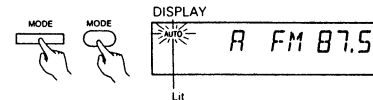

4 Press the TUNING UP or DOWN button.

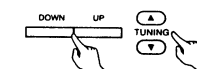

- Automatic searching begins, then stops when a station is tuned in.

NOTE:

- When in the auto tuning mode on the FM band, the "STEREO" indicator lights on the display when a stereo broadcast is tuned in. At open frequencies, the noise is muted and the "TUNED" and "STEREO" indicators turn off.

1 Set the input function to "TUNER".

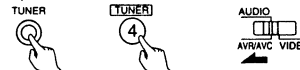

Manual tuning

1 Set the input function to "TUNER".

2 Watching the display, press the BAND button to select the desired band (AM or FM).

3 Press the MODE button to set the manual tuning mode. Check that the display's "AUTO" indicator turns off.

4 Press the TUNING UP or DOWN button to tune in the desired station. The frequency changes continuously when the button is held in.

NOTE:

- When the manual tuning mode is set, FM stereo broadcasts are received in monaural and the "STEREO" indicator turns off.

Preset memory

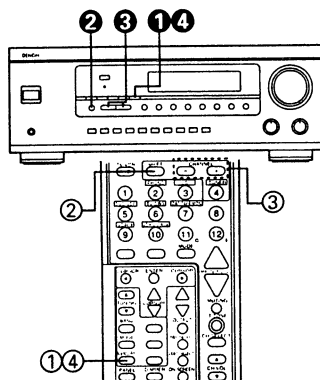

Preparations: Use the "Auto tuning" or "Manual tuning" operation to tune in the station to be preset in the memory.

- 1 Press the MEMORY button.

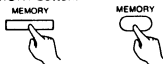

Recalling preset stations

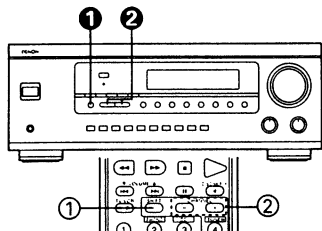

10 LAST FUNCTION MEMORY

- This unit is equipped with a last function memory which stores the input and output setting conditions as they were immediately before the power is switched off.
- The unit is also equipped with a back-up memory. This function provides approximately one week of memory storage when the main unit's power switch is off and with the power cord disconnected.

11 INITIALIZATION OF THE MICROPROCESSOR

When the indication of the display is not normal or when the operation of the unit does not show the reasonable result, the initialization of the microprocessor is required by the following procedure.

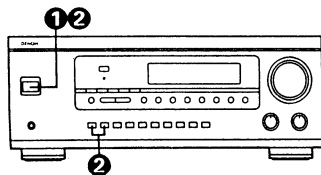

- 2 Press the SHIFT button and select the desired memory block (A to E).

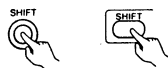

- 3 Press the PRESET UP or DOWN button to select the desired preset channel (1 to 8).

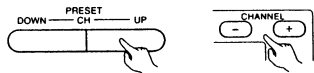

- 4 Press the MEMORY button again to store the station in the preset memory.

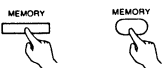

- * To preset other channels, repeat steps 1 to 4. A total of 40 broadcast stations can be preset—8 stations (channels 1 to 8) in each of blocks A to E.

12 TROUBLESHOOTING

If a problem should arise, first check the following:

1. Are the connections correct?
2. Have you operated the receiver according to the Operating Instructions?
3. Are the speakers, turntable, and other components operating properly?

If this unit is not operating properly, check the items listed in the table below. Should the problem persist, there may be a malfunction. Disconnect the power immediately and contact your store of purchase.

	Symptom	Cause	Measures	Page
Common problems arising when listening to the CD, records, tapes, and FM broadcasts, etc.	DISPLAY not lit and sound not produced when POWER operation switch set to on.	<ul style="list-style-type: none"> Power cord not plugged in securely. 	<ul style="list-style-type: none"> Check the insertion of the power cord plug Turn the power on with the remote control unit after turning the POWER operation switch on. 	6 13
	DISPLAY lit but sound not produced	<ul style="list-style-type: none"> Speaker cords not securely connected Improper position of the audio function button. Volume control set to minimum MUTING is on. 	<ul style="list-style-type: none"> Connect securely. Set to a suitable position. Turn volume up to suitable level Switch off MUTING 	8 13 13 14
	DISPLAY is not displayed and the "STANDBY" LED flashes at a high rate.	<ul style="list-style-type: none"> Speaker terminals are short-circuited Block the ventilation holes of the set. The unit is operating at continuous high-power conditions and/or inadequate ventilation. 	<ul style="list-style-type: none"> Switch power off, connect speakers properly, then switch power back on Turn off the set's power, then ventilate it well to cool it down. Once the set is cooled down, turn the power back on. Turn off the set's power, then ventilate it well to cool it down. Once the set is cooled down, turn the power back on. 	8 5 5
	Sound produced only from one channel.	<ul style="list-style-type: none"> Incomplete connection of speaker cords Incomplete connection of input/output cords. 	<ul style="list-style-type: none"> Connect securely. Connect securely. 	8 6, 7
When playing records	Positions of instruments reversed during stereo playback.	<ul style="list-style-type: none"> Reverse connections of left and right speakers or left and right input/output cords. 	<ul style="list-style-type: none"> Check left and right connections 	6-8
	Humming noise produced when record is playing	<ul style="list-style-type: none"> Ground wire of turntable not connected properly. Incomplete PHONO jack connection. TV or radio transmission antenna nearby. 	<ul style="list-style-type: none"> Connect securely. Connect securely. Contact your store of purchase. 	6 6 —
	Howling noise produced when volume is high.	<ul style="list-style-type: none"> Turntable and speaker systems too close together. Floor is unstable and vibrates easily. 	<ul style="list-style-type: none"> Separate as much as possible Use cushions to absorb speaker vibrations transmitted by floor. If turntable is not equipped with insulators, use audio insulators (commonly available). 	— —
	Sound is distorted	<ul style="list-style-type: none"> Stylus pressure too weak. Dust or dirt on stylus. Cartridge defective. 	<ul style="list-style-type: none"> Apply proper stylus pressure. Check stylus. Replace cartridge. 	— — —
Remote control unit	Volume is weak.	<ul style="list-style-type: none"> MC cartridge being used 	<ul style="list-style-type: none"> Replace with MM cartridge or use a head amplifier or step-up transformer. 	6
	This unit does not operate properly when remote control unit is used	<ul style="list-style-type: none"> Batteries dead Remote control unit too far from this unit. Obstacle between this unit and remote control unit. Different button is being pressed ⊕ and ⊖ ends of battery inserted in reverse. 	<ul style="list-style-type: none"> Replace with new batteries Move closer. Remove obstacle Press the proper button Insert batteries properly 	9 9 9 — 9

SPECIFICATIONS

- **Audio section**

- (Power amplifier)

- Rated output:

for North America model:	Front:	65 W + 65 W	(8 Ω / ohms, 20 Hz ~ 20 kHz with 0.05% T.H.D.)
	Center:	65 W	(8 Ω / ohms, 20 Hz ~ 20 kHz with 0.05% T.H.D.)
	Surround:	65 W + 65 W	(8 Ω / ohms, 20 Hz ~ 20 kHz with 0.05% T.H.D.)
for Asia and Taiwan R.O.C. models:	Front:	90 W + 90 W	(6 Ω / ohms, EIAJ)
	Center:	90 W	(6 Ω / ohms, EIAJ)
	Surround:	90 W + 90 W	(6 Ω / ohms, EIAJ)

- Dynamic power:

85 W × 2 ch (8 Ω / ohms)
145 W × 2 ch (4 Ω / ohms)
175 W × 2 ch (2 Ω / ohms)

- Output terminals:

Front/Center:	A or B or Bi-wiring	6 to 16 Ω / ohms
	A + B	12 to 16 Ω / ohms
Surround:	6 to 16 Ω / ohms	

- (Analog)

- Line input (Each line input—FRONT PRE OUT)

Input sensitivity / input impedance:	200 mV / 47 kΩ / kohms
Frequency response:	10 Hz ~ 50 kHz: +1, -3 dB
Tone control range:	BASS: ± 10 dB at 100 Hz
	TREBLE: ± 10 dB at 10 kHz

S/N:	96 dB
Distortion:	0.05% (20 Hz ~ 20 kHz)

Rated output	1.2 V
Maximum headphones output:	27 mW (8 Ω / ohms)

- Phono equalizer (PHONO input —REC OUT)

Input sensitivity:	2.5 mV / 47 kΩ / kohms
RIAA deviation:	± 1 dB (20 Hz to 20 kHz)
S/N:	74 dB (A weighting, with 5 mV input)
Rated output / Maximum output	150 mV / 8 V
Distortion factor:	0.03% (1 kHz, 3V)

- **Video section**

- (Standard video jacks)

Input / output level and impedance:	1 Vp-p, 75 Ω / ohms
Frequency response:	5 Hz ~ 10 MHz +1, -3 dB

- **Tuner section**

Receiving Range:	[FM] (note: μV at 75 Ω / ohms, 0 dBf = 1×10^{-15} W)	[AM]
	87.50 MHz ~ 107.90 MHz (for North America model)	520 kHz ~ 1710 kHz (for North America model)
Usable Sensitivity:	87.50 MHz ~ 108.00 MHz (for Asia and Taiwan R.O.C. models)	522 kHz ~ 1611 kHz (for Asia and Taiwan R.O.C. models)
	1.0 μV (11.2 dBf)	18 μV
50 dB Quietening Sensitivity:	MONO 1.6 μV (15.3 dBf)	
	STEREO 23 μV (38.5 dBf)	
S/N: (IHF-A):	MONO 80 dB	50 dB
	STEREO 75 dB	
Total Harmonic Distortion (at 1 kHz):	MONO 0.15%	
	STEREO 0.3%	

- **General**

Power supply:	AC 120 V, 60 Hz (for North America and Taiwan R.O.C. models)
	AC 230 V, 50 Hz (for Asia model)
Power consumption:	4.0 A (for North America model)
	190 W (for Asia and Taiwan R.O.C. models)
Maximum external dimensions:	434 (W) × 161 (H) × 416 (D) mm (17-3/32" × 6-11/32" × 16-3/8") (AVR-1400)
	470 (W) × 162 (H) × 416 (D) mm (18-1/2" × 6-3/8" × 16-3/8") (AVR-1420)
Weight:	10.6 kg (23 lbs 6 oz) (AVR-1400)
	12.0 kg (26 lbs 7 oz) (AVR-1420)

- **Remote control unit (RC-832)**

Batteries:	R6P/AA Type (two batteries)
External dimensions:	70 (W) × 215 (H) × 19 (D) mm (2-3/4" × 8-15/32" × 3/4")
Weight:	180 g (Approx. 6 oz) (including batteries)

* For purposes of improvement, specifications and design are subject to change without notice.

WIRE ARRANGEMENT

In case of wires require unclasping or loosening to move the location to perform adjustment or part replacement, be sure to rearrange them neatly to restore properly in the same location as they were originally placed, or causing to produce a noise may occasionally occur.

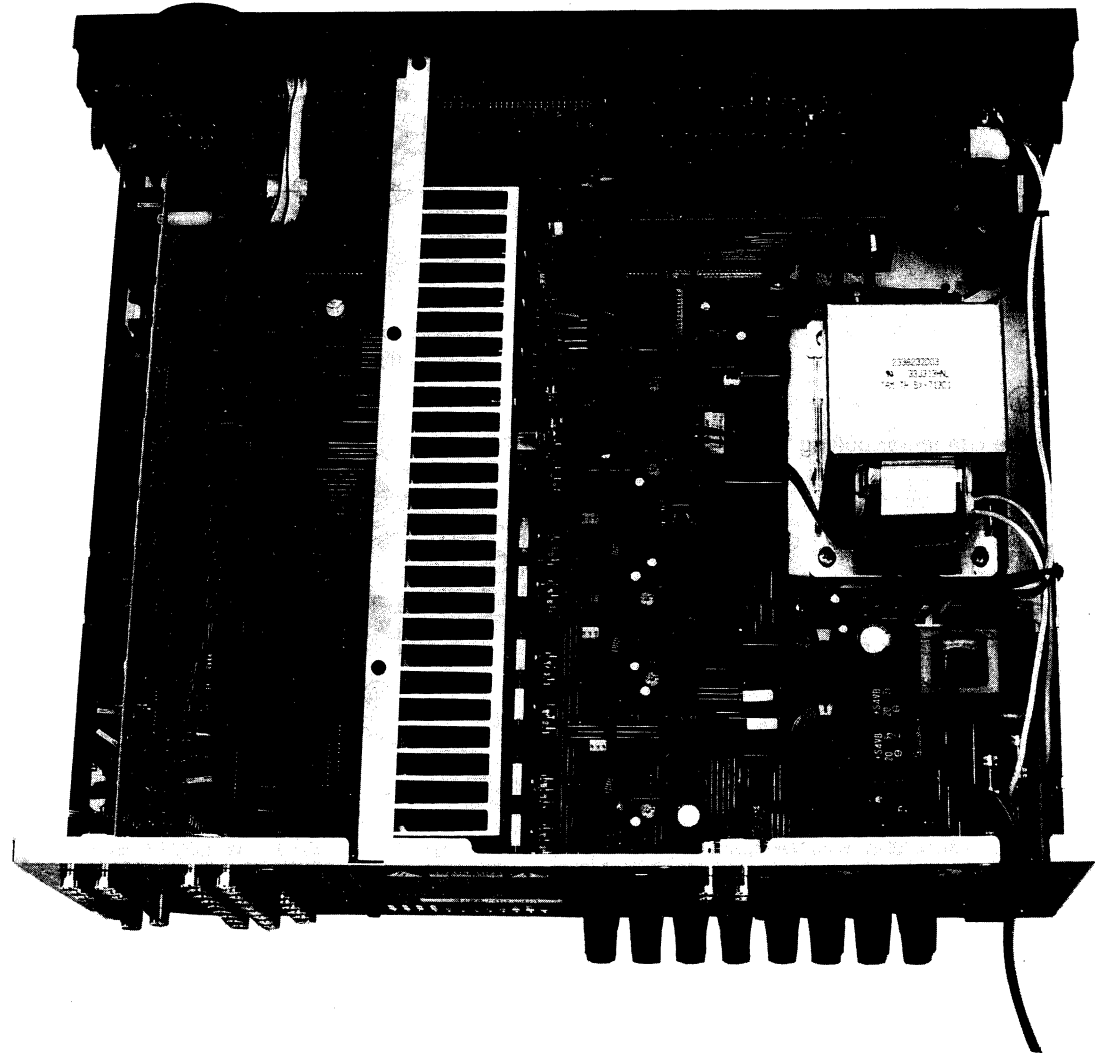

DISASSEMBLY

(To reassemble reverse disassembly)

1. Front Aluminium Panel

- 1) Pull out 3 Knobs.
- 2) Remove 5 screws ① and ②.
- 3) Unfasten 3 upper hooks and 2 below hooks.

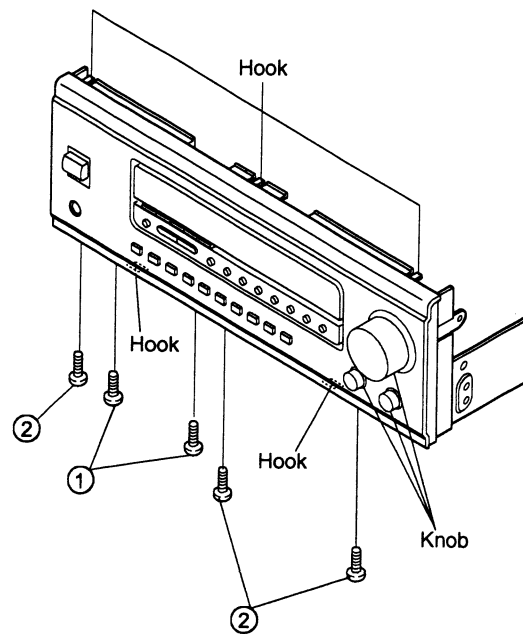

2. Front Mold Panel

- 1) Remove 4 screws ③, ④.
- 2) Detach the Front Mold Panel in the arrow direction as it connects with connectors.

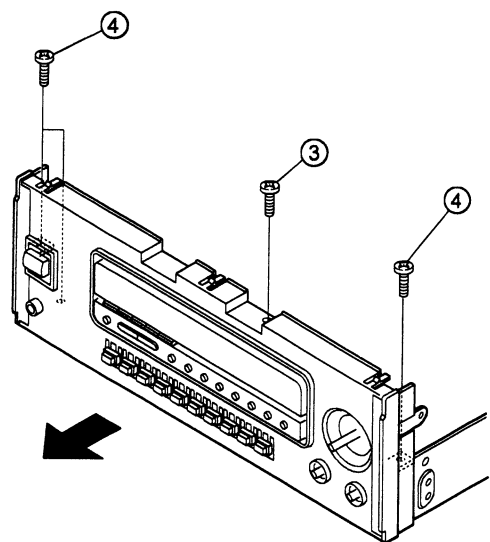

● Disassembling P.W.Board

- 3) Remove 3 nuts ⑤ and 11 screws ⑥, ⑦, ⑧.

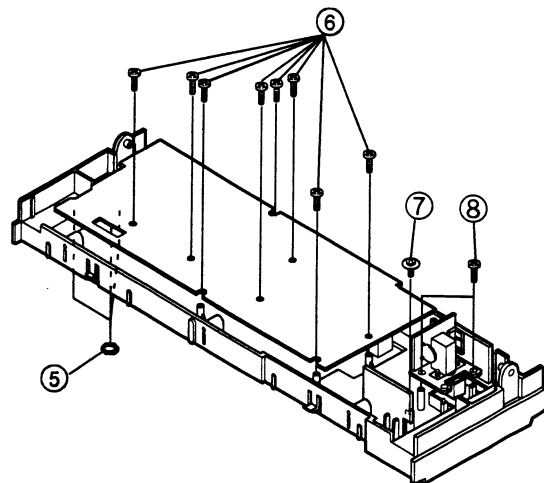

3. Tuner, Audio In and C-Video Unit

- 1) Remove 23 screws ⑦, ⑧.
- 2) Disconnect the connector, pulling the objective Unit in the arrow direction.

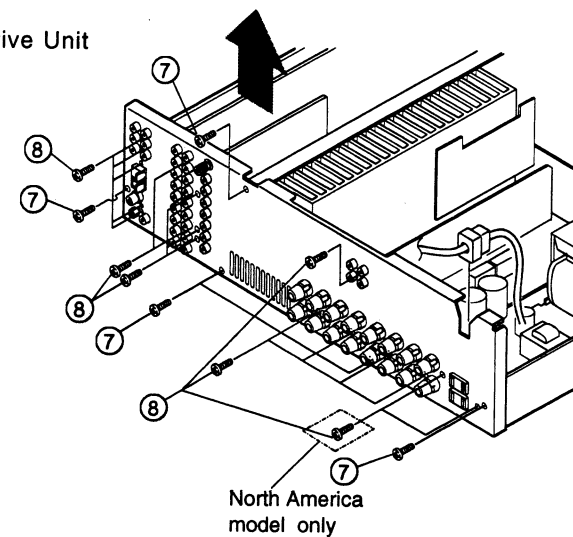

4. Amp Unit

- 1) Remove 1 screw ⑨.
- 2) Disconnect from the connector, pulling in the arrow direction ①.

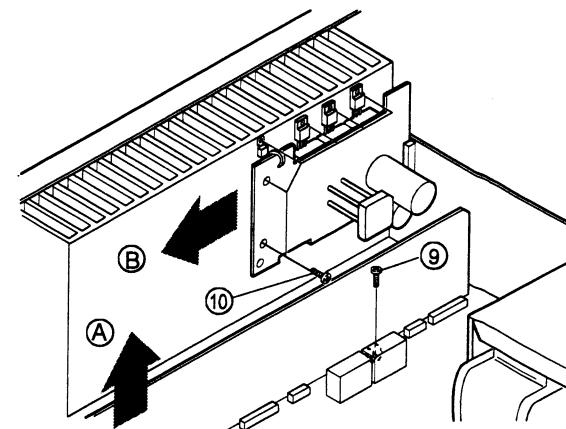

5. Regulator Unit

- 1) Remove 6 screws ⑩.
- 2) Disconnect from the connector, pulling in the arrow direction ②.

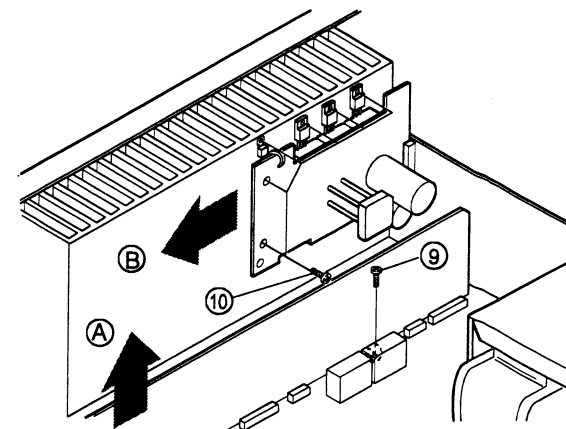

6. When Maintenance for Control Unit (1U-3065-1) and Power Unit (1U-3066-1)

- 1) Unfasten the Front Aluminium Panel.
- 2) Remove 14 screws ⑪, ⑫.
- 3) Unfasten the hooks of Holder ③.
- 4) Then separate Chassis only, and by standing it in the arrow direction, it is possible to check with power on.

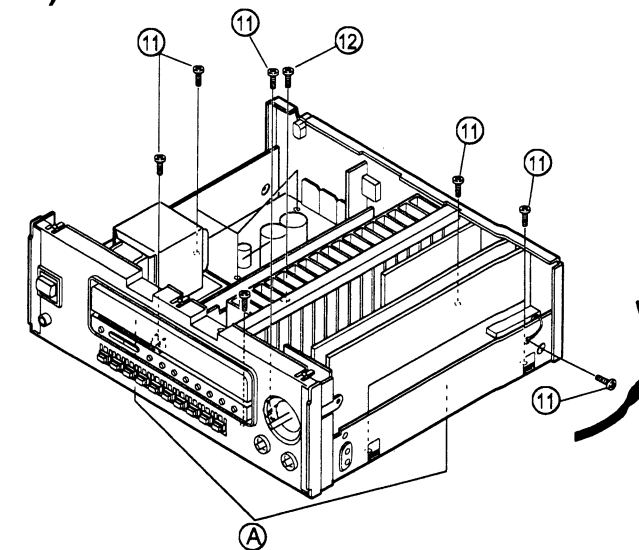

BLOCK DIAGRAM

1 2 3 4 5 6 7 8

A

B

C

D

E

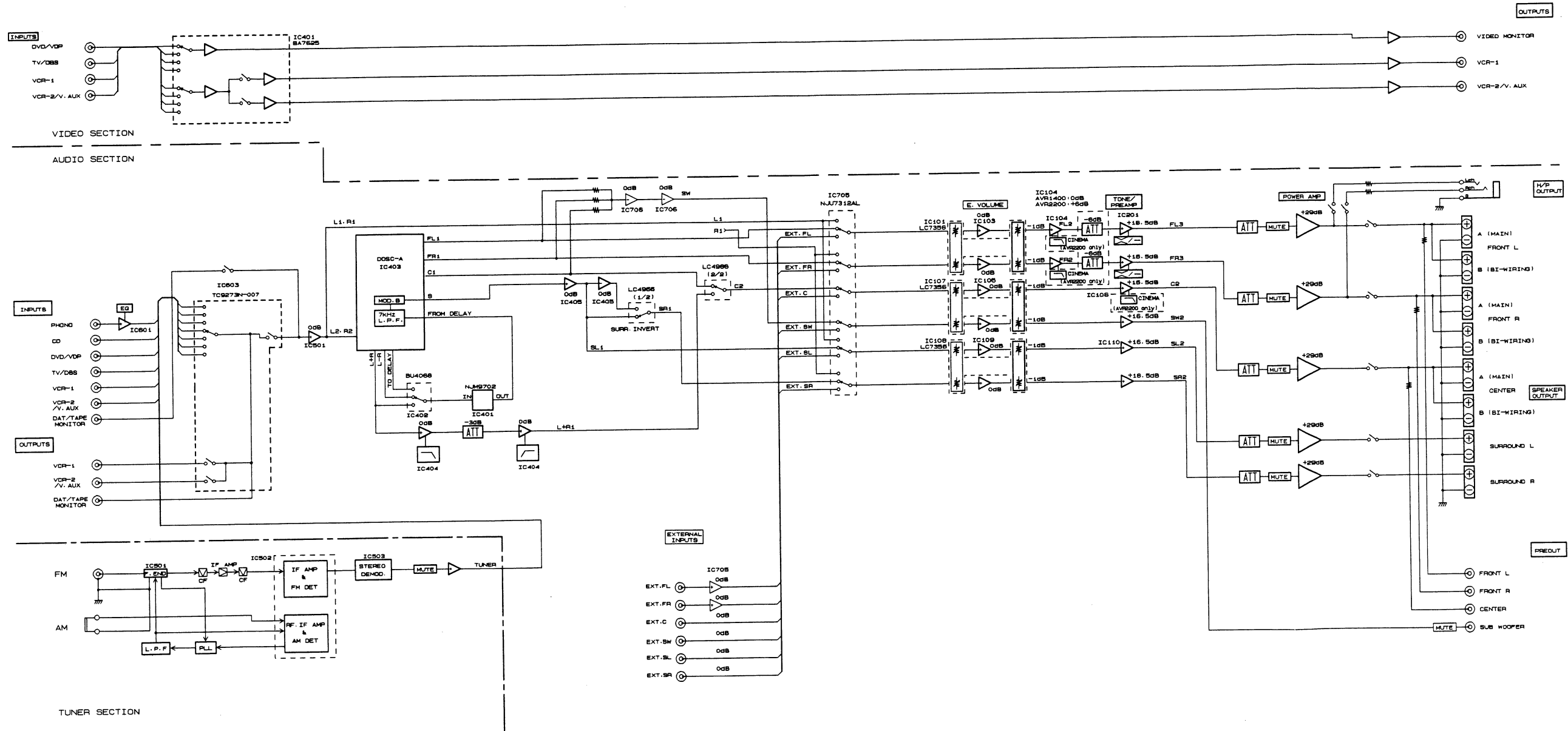

BLOCK LEVEL DIAGRAM

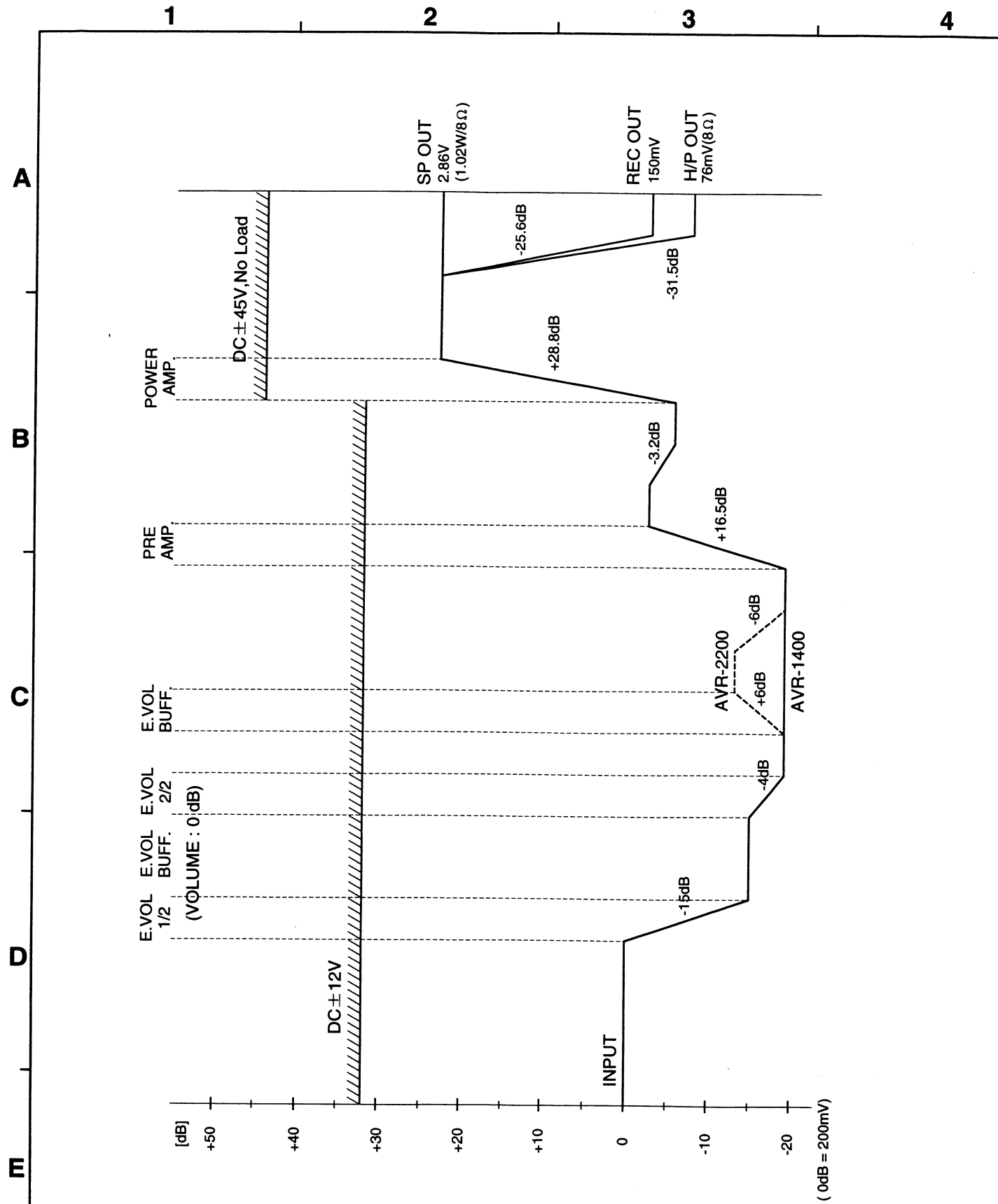

ADJUSTMENT

Tuner Section

CONNECTION DIAGRAM OF MEASURING INSTRUMENTS

● FM

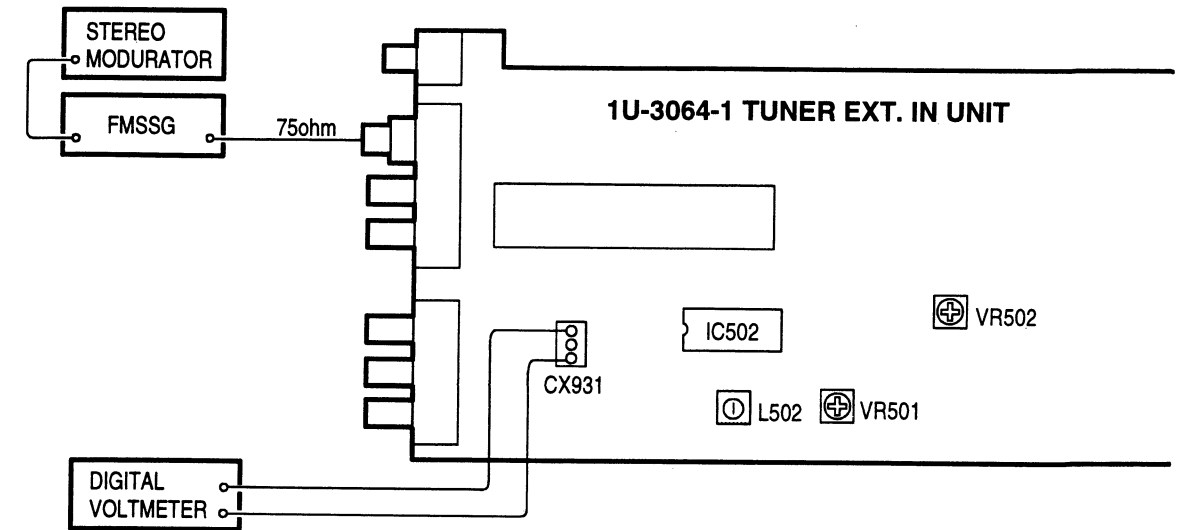

● AM

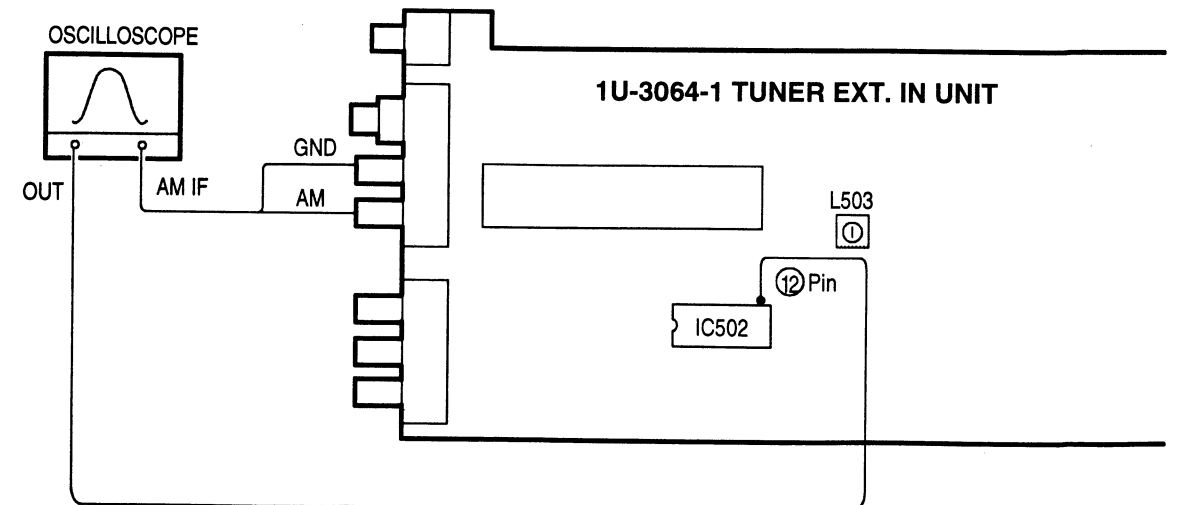

FM/MPX ALIGNMENT

Step	Alignment Item	Tuning Frequency Setting	Input					Output		Adjust		Remarks
			Type	Frequency	Input Level	Modulation	Coupling	Type	Connect to	Points	Adjust to	
1	Tuning Center	98.1 MHz	FM SSG	98.1 MHz	60 dB μ	None	Antenna Terminal	Digital Voltmeter	CX931	L502	\pm 50mV	Function : FM Mode : Auto
2	Separation	98.1 MHz	FM SSG	98.1 MHz	60 dB μ	Stereo (L) 1KHz 100%	Antenna Terminal	AC Voltmeter	AUDIO OUT Terminal (R)	VR502	Maximum Separation	—
3	Signal Level	98.1 MHz	FM SSG	98.1 MHz	20 dB μ	Off	Antenna Terminal	—	—	VR501	Light "TUNED" FLD Character	—

AM ALIGNMENT

Step	Alignment Item	Frequency	Input	Output		Adjustment		Remarks
				Type	Connect to	Points	Adjust to	
1	IF	—	IF SWEEP (Input level is not over to work A.G.C.)	Oscilloscope	IC502 12Pin	L503	Maximum height and best symmetry curve	

Audio Section

Idling Current (1U-3066-1)

Required measurement equipment : DC Voltmeter

Arrangement

- (1) Avoid direct blow from an air conditioner or an electric fan, and adjust the unit at normal room temperature 15 °C ~ 30 °C (59 °F ~ 86 °F).
- (2) Presetting
 - POWER (Power source switch) → OFF
 - VOLUME (Volume control) → "..." : fully counterclockwise (⌚ min.)
 - BASS, TREBLE (Tone control) → FLAT: (Controls to center)
 - SPEAKER-A (Speaker terminal) → No load (Do not connect speaker, dummy resistor, etc.)

Adjustment

- (1) Remove top cover and set VR501, VR502, VR503, VR504, VR505, on 1U-3066-1 (Power Unit) at counterclockwise (⌚) fully.
- (2) Connect DC Voltmeter to test points (FRONT-Lch: TP501, FRONT-Rch: TP502, CENTER ch: TP503, SURROUND-Lch: TP504, SURROUND-Rch: TP505).
- (3) Connect power cord to AC Line, and turn power switch "ON".
- (4) Presetting. MODE : 5CH STEREO
 FUNCTION : CD
- (5) Allow 2 minutes, and turn VR501 clockwise (⌚) and adjust the TEST POINTS voltage to 1.5 mV ±0.5 mV DC.
- (6) After 10 minutes from preset, turn VR501 to set the voltage to 3 mV ±0.5 mV DC.
- (7) Adjust the Variable Resistors of other channels in the same way.

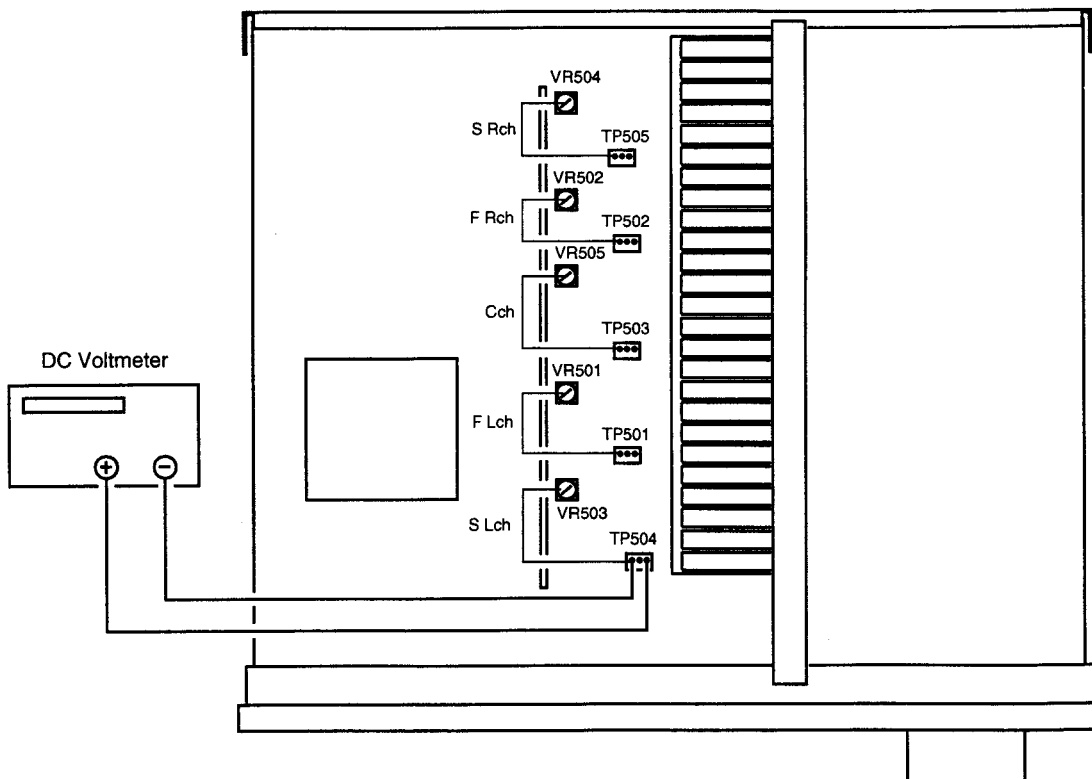

SEMICONDUCTORS

● IC's

Note: Indications before IC numbers denote P.W.B. name.

- AU** : Audio in, Display Unit
- TU** : Tuner, Volume, Video Unit
- CO** : Control, Power Unit
- PA** : Power Amp Unit

TMP87CS71F-6631 (CO: IC113)

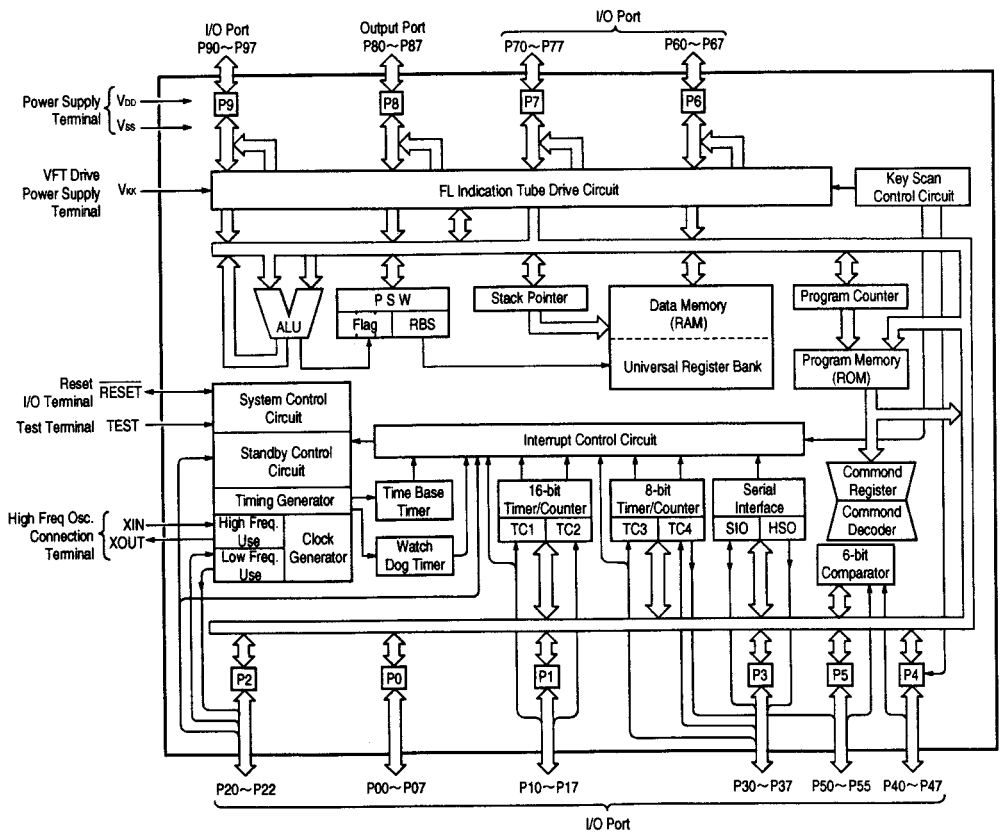
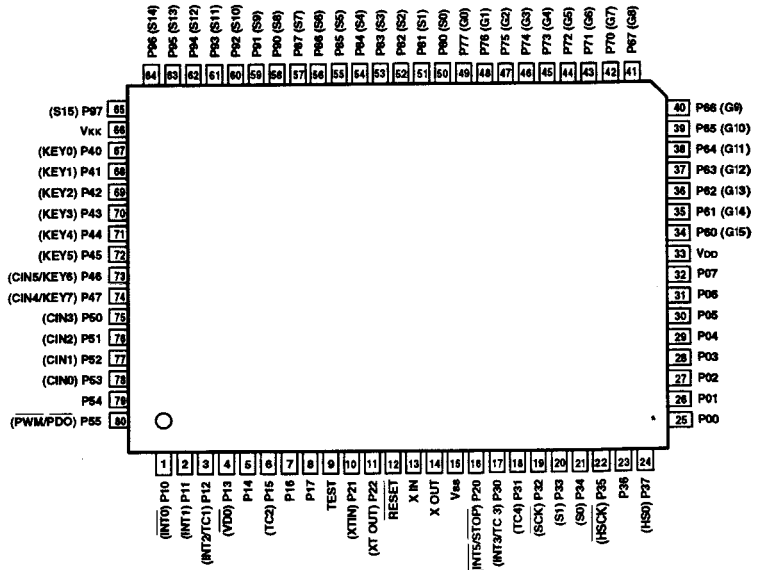
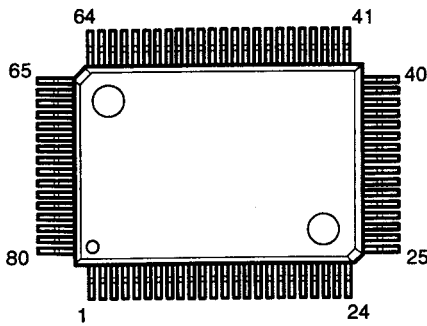

TMP87CS71F-6631 (IC113) Terminal Function

Pin No.	Port Name	Symbol	I/O	Type	Op	Det	Res	Init	Function
1	P10/INT 0	PROTECTION IN	I	—	Eu	E&L	Z	—	Protection detecting input. (L: Detected)
2	P11/INT 1	EFFECT	O	C	—	—	Z	L	Surround signal select output.
3	P12/INT 2	RDS START	I	—	Eu	Ed	Z	—	RDS data input (LC7074). *E2 model only.
4	P13/DVO	STEREO/MONO	O	C	—	—	Z	L	STEREO/MONO control signal. (L: STEREO receiving)
5	P14	PLL-ST	O	C	—	—	Z	L	LM7001 control output.
6	P15/TC2	PLL-CLK	O	C	—	S	Z	L	LM7001 control output.
7	P16	PLL-DATA	O	C	—	S	Z	L	LM7001 control output.
8	P17	TUNER MUTE	O	C	—	—	Z	H	Tuner mute output. (H: Mute)
9	TEST	TEST	I	—	GND	S	—	—	Connect to ground.
10	P21/XTIN	STEREO SIGNAL	I	—	Eu	Lv	Z	—	STEREO control signal. (L: STEREO receiving)
11	P22/XTO	TUNED SIGNAL	I	—	Eu	Lv	Z	—	Tuning detection. (L: Tuning)
12	RESET	RESET	I	—	Eu	Lv	L	—	Reset input.
13	XIN	XIN	I	—	—	—	—	—	Oscillator circuit terminal. (4MHz)
14	XOUT	XOUT	O	—	—	—	—	—	Oscillator circuit terminal. (4MHz)
15	VSS	GND	I	—	GND	—	—	—	Ground.
16	P20/INT 5	POWER OFF	I	—	Eu	Lv	Z	—	Power OFF detection terminal. (L: Power OFF)
17	P30/INT 3	REMOCON	I	—	Ed	E&L	Z	—	Remote signal input.
18	P31/TC4	RDS RST	O	N	—	—	Z	L	RDS reset output (LC7074). *E2 model only.
19	P32/SCK	RDS CLK	I	—	—	S	Z	—	RDS clock input (LC7074).
20	P33/SI	RDS DATA	I	—	—	S	Z	—	RDS data input (LC7074).
21	P34/SO	OSD RST	O	N	Eu	—	Z	H	OSD control output. (M35015), AVR1400/2200: Lout fixed
22	P35/HSCK	OSD CLK	O	N	Eu	S	Z	H	OSD control output. (M35015), AVR1400/2200: Lout fixed
23	P36	OSD CS	O	N	Eu	—	Z	H	OSD control output. (M35015), AVR1400/2200: Lout fixed
24	P37/HSO	OSD DATA	O	N	Eu	S	Z	L	OSD control output. (M35015), AVR1400/2200: Lout fixed
25	P00	POWER	O	C	—	—	Z	H	Power supply relay control output. (H: ON)
26	P01	FL RST	O	C	—	—	Z	L	Fluorescent display control output. (MSC1937)
27	P02	FL DATA	O	C	—	—	Z	L	Fluorescent display control output. (MSC1937)
28	P03	FL CLK	O	C	—	—	Z	L	Fluorescent display control output. (MSC1937)
29	P04	DD REQ	O	C	—	—	Z	L	Digital delay control output. (NJU9702G)
30	P05	DD DATA	O	C	—	—	Z	L	Digital delay control output. (NJU9702G)
31	P06	DD CLK	O	C	—	—	Z	L	Digital delay control output. (NJU9702G)
32	P07	SURR.LPF	O	C	—	—	Z	L	Surround signal frequency response select output. (H: LPF ON)
33	VDD	VDD	I	—	—	—	—	—	Connect to +5V power supply.
34	P60	A	O	P	Id	—	Z	H	Video input control output. (BA7625, BA7626) (L: Select)
35	P61	B	O	P	Id	—	Z	H	Video input control output. (BA7625, BA7626) (L: Select)
36	P62	E. VOL CE2	O	P	Id	—	L	L	Electronic volume control output. (LC7536) (Center/Sub woofer, Rear L/R)
37	P63	E. VOL CE1	O	P	Id	—	L	L	Electronic volume control output. (LC7536) (Front L/R)
38	P64	E. VOL DATA	O	P	Id	—	L	H	Electronic volume control output. (LC7536)
39	P65	E. VOL CK	O	P	Id	—	L	H	Electronic volume control output. (LC7536)
40	P66	SURR INVERT	O	P	Id	—	L	L	Surround signal invert control output.
41	P67	CINEMA	O	P	Id	—	L	L	Cinema Equalizer control output. (H: ON)
42	P70	PRO. CNT-E	O	P	Id	—	L	H	Test tone control output.
43	P71	PRO. CNT-A	O	P	Id	—	L	L	Test tone control output.
44	P72	PRO. CNT-B	O	P	Id	—	L	L	Test tone control output.
45	P73	PRO. NORMAL	O	P	Id	—	L	L	Center mode control output.
46	P74	PRO. WIDE	O	P	Id	—	L	H	Center mode control output.
47	P75	VOL. MUTE	O	P	Id	—	L	L	Control signal at minus infinite of master volume. (L: infinite)
48	P76	SUR	O	P	Id	—	L	H	Surround signal select control output.
49	P77	L+R	O	P	Id	—	L	H	Surround signal select control output.
50	P80	L-R	O	P	Id	—	L	H	Surround signal select control output.
51	P81	STANDBY LED	O	P	Id	—	L	H	Standby indication LED drive output. (H: Lighting)
52	P82	PRO LOGIC LED	O	P	Id	—	L	H	Pro Logic indication LED drive output. (H: Lighting)
53	P83	H/P MUTE	O	P	Id	—	L	H	Headphone and pre-output relay control output. (L: Mute)
54	P84	SP-CENTER	O	P	Id	—	L	L	Center speaker relay control output. (L: Mute)
55	P85	SP-REAR	O	P	Id	—	L	L	Rear speaker relay control output. (L: Mute)

Pin No.	Port Name	Symbol	I/O	Type	Op	Det	Res	Ini	Function
56	P86	SP-A	O	P	Id	—	L	H	Front speaker relay control output. (L: Mute)
57	P87	SUB WOOFER MUTE	O	P	Id	—	L	H	Sub woofer mute output. (L: Mute)
58	P90	C	O	P	Id	—	Z	H	Video input control output. (BA7625, BA7626) (L: Select)
59	P91	D	O	P	Id	—	Z	H	Video input control output. (BA7625, BA7626) (L: Select)
60	P92	E	O	P	Id	—	Z	H	Video input/output control output. (BA7625, BA7626)(L:Select)
61	P93	S2	O	P	Id	—	L	—	Video signal select control output, AVR1400/2200: Lout Fixed
62	P94	S1	O	P	Id	—	L	—	Video signal select control output, AVR1400/2200: Lout Fixed
63	P95	FUNC CLK	O	P	Id	S	L	L	Function control output. (TC9273-007,-004, NJU7312AL)
64	P96	FUNC DATA	O	P	Id	S	L	L	Function control output. (TC9273-007,-004, NJU7312AL)
65	P97	FUNC ST1	O	P	Id	—	L	L	Function control output. (TC9273-007,-004)
66	VKK	VKK	I	—	—	—	—	—	Connect to ground.
67	P40/KEY0	FUNC ST2	O	N	Eu	—	Z	L	Function control output. (NJU7312AL)
68	P41/KEY1	S-MONITOR DET.	I	—	Eu	Lv	Z	—	Judgement whether S monitor is connected or not (L: Connecting input),AVR1400: Lout fixed
69	P42/KEY2	S-SIGNAL DET.	I	—	Eu	Lv	Z	—	S signal input control. (H: S signal input),AVR1400: Lout fixed
70	P43/KEY3	OSD SYNC DET.	I	—	Eu	Lv	Z	—	OSD sync switching signal. (H: External sync),AVR1400/2200: Lout fixed
71	P44/KEY4	VSEL A	I	—	Eu	—	Z	—	Master volume setting signal. (Rotary encode)
72	P45/KEY5	VSEL B	I	—	Eu	—	Z	—	Master volume setting signal. (Rotary encode)
73	P46/CIN5	MODE	I	—	Eu	Lv	Z	—	Version select.
74	P47/CIN4	KEY5	I	—	Eu	Lv	Z	—	Key input 5.
75	P50/CIN3	KEY4	I	—	Eu	Lv	Z	—	Key input 4.
76	P51/CIN2	KEY3	I	—	Eu	Lv	Z	—	Key input 3.
77	P52/CIN1	KEY2	I	—	Eu	Lv	Z	—	Key input 2.
78	P53/CIN0	KEY1	I	—	Eu	Lv	Z	—	Key input 1.
79	P54	TAPE MONITOR	O	N	Eu	—	Z	H	Tape Monitor control output. (H: Tape Monitor On)
80	P55/PMW	MODE.M	I	—	Eu	—	Z	—	Version select.

NOTE:

Pin No. : Terminal number of microcomputer.

Port Name : The name entered in the data sheet of microcomputer.

Symbol : Symbolized interface function.

I/O : Input or out of part.

"I" = Input port
 "O" = Output port

Type : Composition of port in case of output port.

"C" = CMOS output
 "N" = NMOS open drain output
 "P" = PMOS open drain output

Op : Pull up/Pull down selection information.

"Iu" = Inner microcomputer pull up
 "Id" = Inner microcomputer pull down
 "Eu" = External microcomputer pull up
 "Ed" = External microcomputer pull down

Det : Indicates judging state of input port. Level detection is "LV"; Edge detection is "Ed"; Detection by both shifting is "E&L"; Serial data detection is "S" (Serial data output is also "S").

Res : State at reset.

"H" = Outputs High Level at reset
 "L" = Outputs Low Level at reset
 "Z" = Becomes High impedance mode at reset

Ini : Initial output state.

Function : Function and logical level explanation of signals to be interface.

LC7536
(TU: IC101, 107, 108)

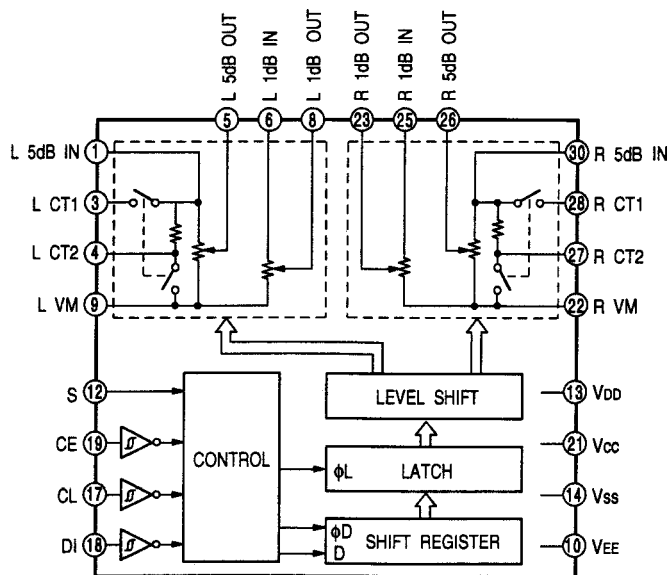
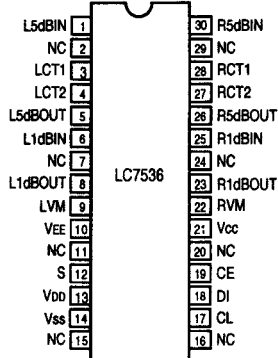
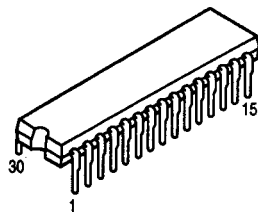

LC7536 Terminal Function

Pin No.	Symbol	I/O	Function
1	L 5dB IN	I	Input terminal for 5dB step attenuator, it should be driven with low impedance path.
2	NC	-	No connection.
3	L CT1	I	For loudness control, connect a capacitor between CT1 and 5dB IN with high frequency compensation, and also connect a capacitor between CT2 and Vm with low frequency compensation.
4	L CT2		
5	L 5dBOUT	O	Output terminal for 5dB step attenuator with approx. 1Mohm load impedance.
6	L 1dBIN	I	Input terminal for 1dB step attenuator, it should be driven with low impedance.
7	NC	-	No connection.
8	L 1dBOUT	O	Output terminal for 1dB step attenuator with approx. 47kohm ~ 1Mohm load impedance.
9	L Vm		Common terminal for volume control.
10	VEE	I	Connect to power supply.
11	NC	-	No connection.
12	S		Selection terminal for address code during data format.
13	VDD	I	Connect to power supply (Pay attention to the rising time so that Vcc does rise up faster than VDD when the power turns).
14	VSS	I	Connect to power supply.
15	NC	-	No connection.
16	NC	-	No connection.
17	CL	I	Input terminal for controlling LC7536 serial data with 0 ~ 5V amplitude.
18	DI		
19	CE		
20	NC	-	No connection.
21	VCC	I	Connect power supply (Pay attention to the rising time so that Vcc does not rise up faster than VDD when the power turns).
22	R Vm		Common terminal for volume control.
23	R 1dBOUT	O	Output terminal for 1dB step attenuator with approx. 47kohm ~ 1Mohm load impedance.
24	NC	-	No connection.
25	R 1dBIN	I	Input terminal for 1dB step attenuator, it should be driven with low impedance.
26	R 5dBOUT	O	Output terminal for 5dB step attenuator with approx. 1Mohm load impedance.
27	R CT2	I	For loudness control, connect a capacitor between CT1 and 5dBIN with high frequency compensation, and also connect a capacitor between CT2 and Vm with low frequency compensation.
28	R CT1		
29	NC	-	No connection.
30	R 5dBIN	I	Input terminal for 5dB step attenuator, it should be driven with low impedance path.

MSC1937-03RS
(AU: IC102)

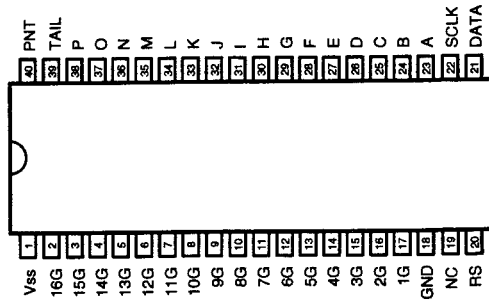
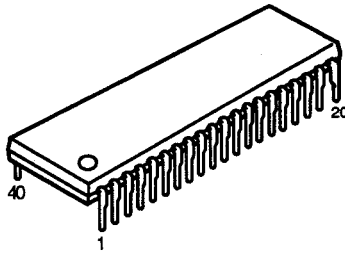

MSC1937-03RS Terminal Function

Pin No.	Symbol	I/O	Function
1	Vss	-	Power supply (+5V).
2	16G	O	Digit 16 output.
3	15G	O	Digit 15 output.
4	14G	O	Digit 14 output.
5	13G	O	Digit 13 output.
6	12G	O	Digit 12 output.
7	11G	O	Digit 11 output.
8	10G	O	Digit 10 output.
9	9G	O	Digit 9 output.
10	8G	O	Digit 8 output.
11	7G	O	Digit 7 output.
12	6G	O	Digit 6 output.
13	5G	O	Digit 5 output.
14	4G	O	Digit 4 output.
15	3G	O	Digit 3 output.
16	2G	O	Digit 2 output.
17	1G	O	Digit 1 output.
18	GND	-	Ground.
19	NC	-	No connection.
20	RS	I	POWER-ON-RESET. (H: RESET)
21	DATA	I	Data input.
22	SCLK	I	Shift clock input.
23	A	O	Segment A output.
24	B	O	Segment B output.
25	C	O	Segment C output.
26	D	O	Segment D output.
27	E	O	Segment E output.
28	F	O	Segment F output.
29	G	O	Segment G output.
30	H	O	Segment H output.
31	I	O	Segment I output.
32	J	O	Segment J output.
33	K	O	Segment K output.
34	L	O	Segment L output.
35	M	O	Segment M output.
36	N	O	Segment N output.
37	O	O	Segment O output.
38	P	O	Segment P output.
39	TAIL	-	No connection.
40	PNT	O	Point output.

**BA7625 (TU: IC401)
(BA7626)**

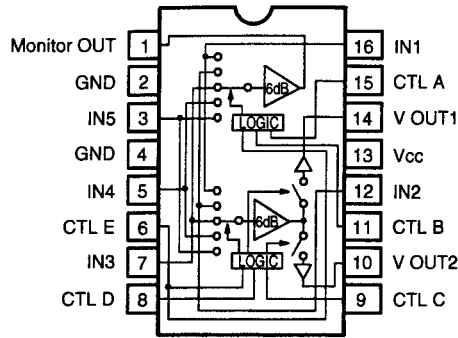
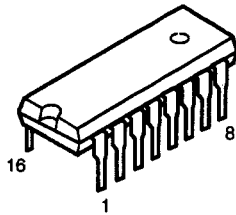

A	B	E	MONITOR OUT
L	L	*	IN 1
H	L	*	IN 2
L	H	*	IN 3
H	H	L	IN 4
H	H	H	IN 5

C	D	E	V OUT 1
L	L	*	—
H	L	*	IN 2
L	H	*	IN 3
H	H	L	IN 4
H	H	H	IN 5

C	D	E	V OUT 2
L	L	*	IN 1
H	L	*	—
L	H	*	IN 3
H	H	L	IN 4
H	H	H	IN 5

Note 1: * mark means that feasible for either H or L.
 Note 2: Each input terminal is provided with sink chip clamp (BA7625).
 Each input terminal takes 20kohm at the end (BA7626).

**NJU9702G
(AU: IC401)**

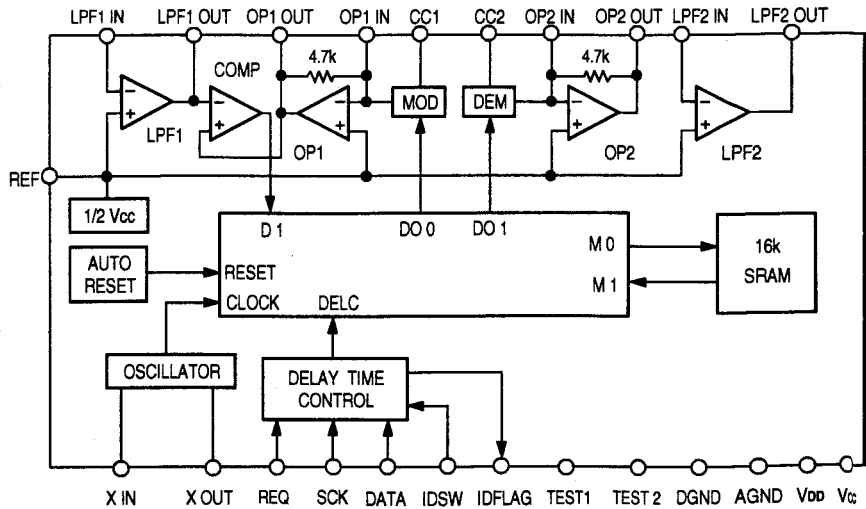
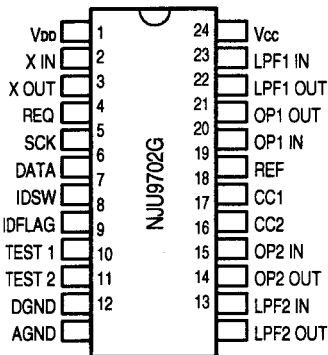

**BU4066BCF
(AU: IC402)**

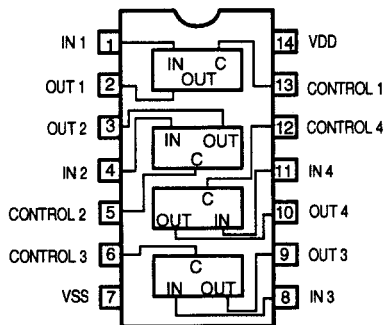
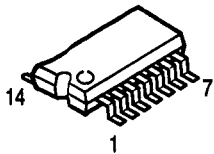

**LC4966
(AU: IC704)**

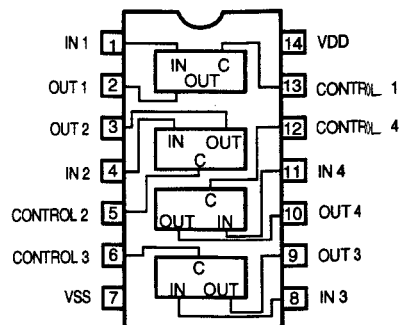
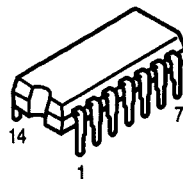

DDSC-A
(AU: IC403)

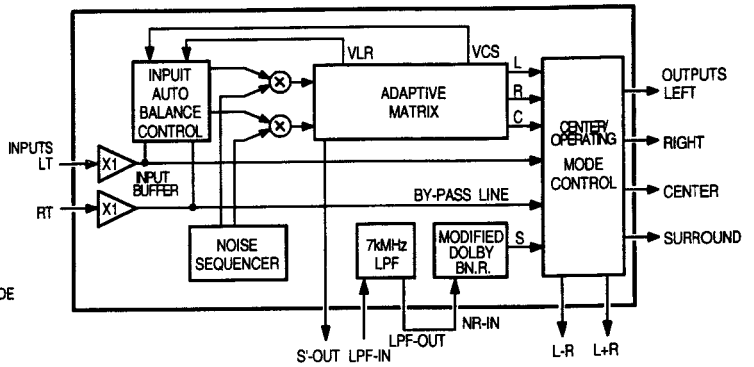
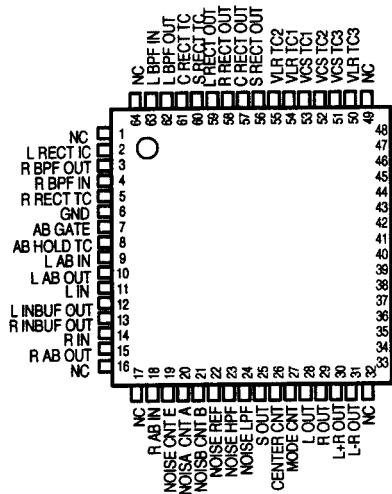

LA1265 (S)
(TU: IC502)

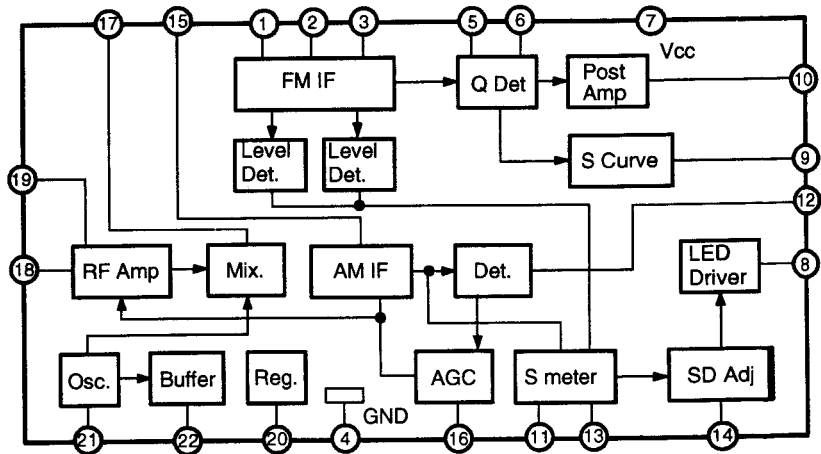
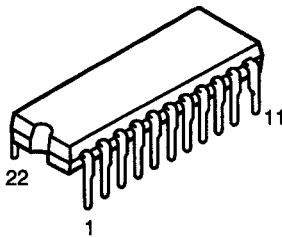

LA3401
(TU: IC503)

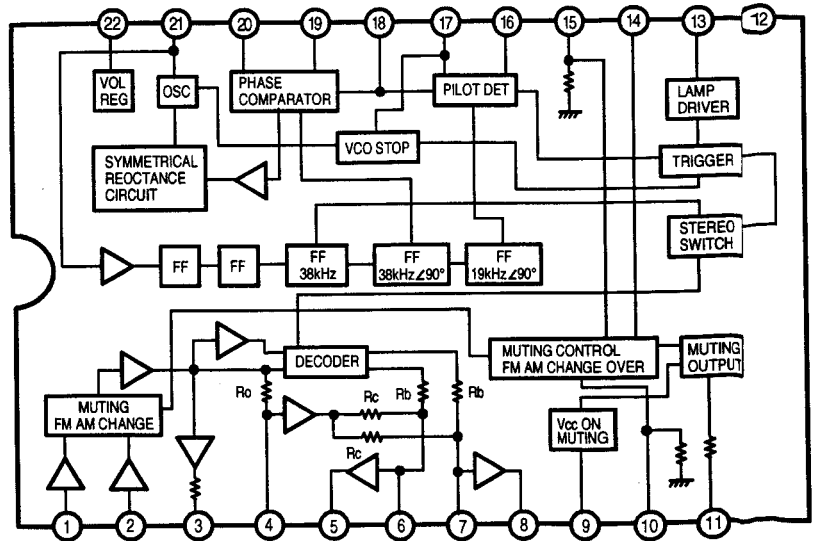
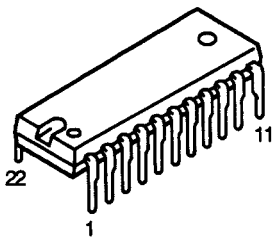

BA15218F (AU: IC404, 405, 706)
 (TU: IC105,106,109,110)
 NJM2068MD(AU: IC201,501,601)
 (TU: IC103, 104,701)

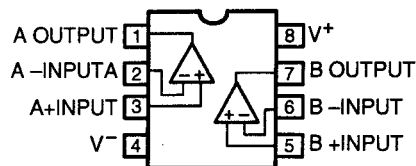
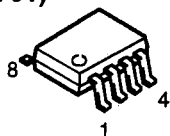

LM7001 (TU: IC505)

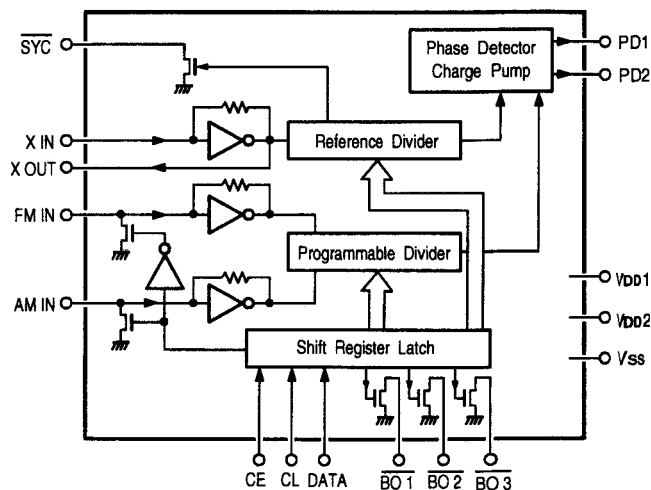
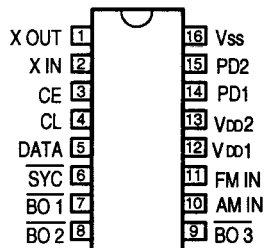
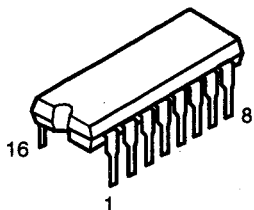

TC9273N-007 (AU: IC603)

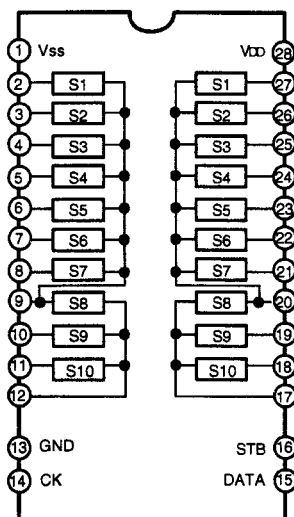
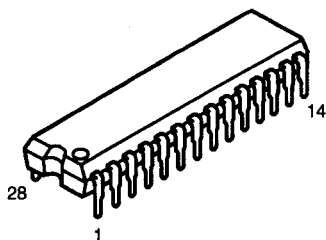

TC9273N Terminal Function

Pin No.	Symbol	Name	Function	Note
1	Vss	-Power Terminal	Dual Power Use: VDD = 8.0~17 V GND = 0V Vss = -8.0~17V	Signal Power Use: VDD = 8.0~18V Vss = GND = 0V
13	GND	Digital Ground		
28	VDD	+Power Terminal		
2-12 17-27	S1-11	I/O Terminal	Input terminal of analog switch.	—
14	CK	Clock Input	Clock input for data transfer.	Low level Border Input Terminal
15	DATA	Data Input	Serial input for switch setting.	
16	STB	Strobe Input	Strobe input for data writing.	

NJM7806FA (S) (PA: IC502, 505)
 NJM7812FA (S) (PA: IC503)

NJM7912FA (PA: IC504)

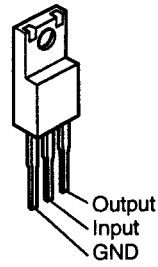
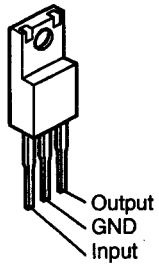

NJU7312AL (TU: IC705)

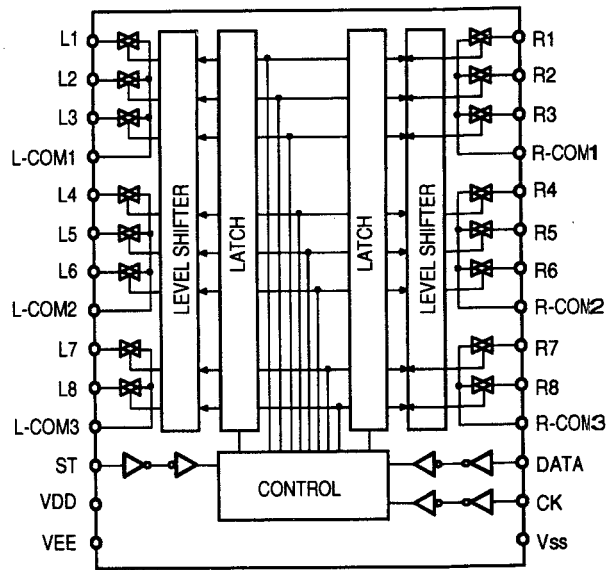
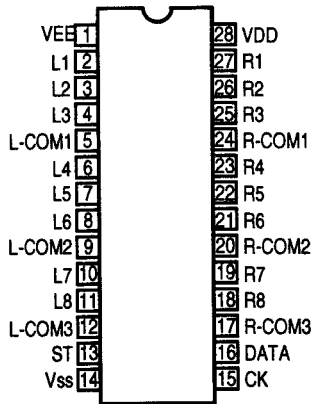
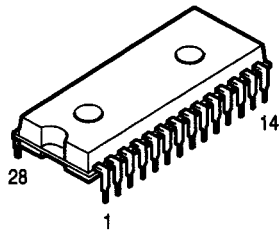

● IC PROTECTOR
 ICP-N15 (PA: IC501)

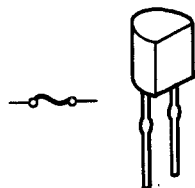

● TRANSISTORS

2PA1015GR
 2SA970 (BL)
 2SA988 (E/F)
 2SC1841 (E/F)
 2SC2878 (A/B)

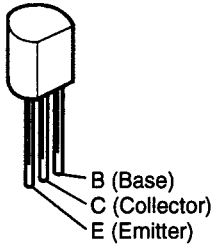

2SC2705 (O)/(Y)
 2SD1292 (R)

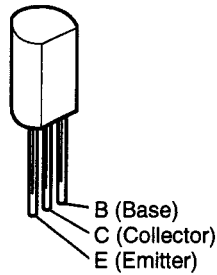

2SA1491 (O/P/Y)
 2SC3855 (O/P/Y)

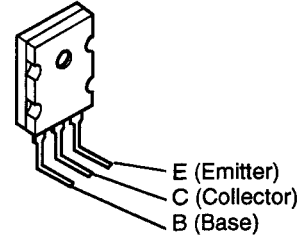

DTA114ES
 DTC114ES

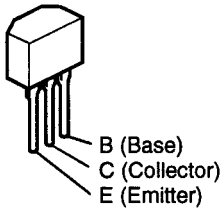

DTA114ES

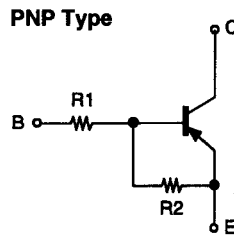

	R1	R2
DTA114ES	10kohm	10kohm

DTC114ES

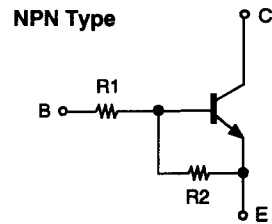

	R1	R2
DTC114ES	10kohm	10kohm

DTA114TK
 DTA114EK
 DTA144EK
 DTC114EK
 DTC144EK
 DTC323TK
 RN2402

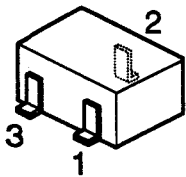

1: GND/Emitter
 2: Out/Collector
 3: In/Base

DTA114TK
 DTA114EK
 DTA144EK
 RN2402

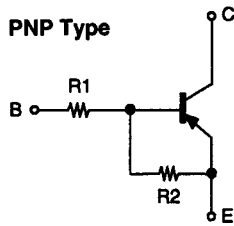

	R1	R2
DTA114EK	10kohm	-
DTA114EK	10kohm	10kohm
DTA144EK	47kohm	47kohm
RN2402	10kohm	10kohm

DTC114EK
 DTC144EK
 DTC323TK

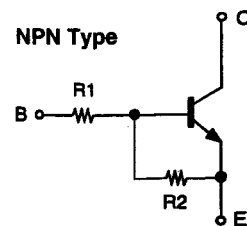

	R1	R2
DTC114EK	10kohm	10kohm
DTC144EK	47kohm	47kohm
DTC323TK	2.2kohm	-

2SA933S (S)
2SC3311A
2SC1740S (S)

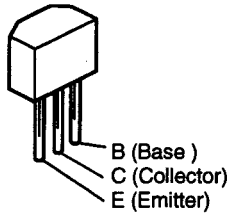

2SK209 (GR)

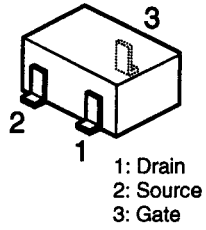

2SD601A

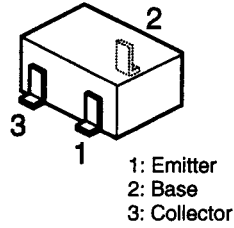

2SC2712 (Y/GR)
2SC2996 (Y)

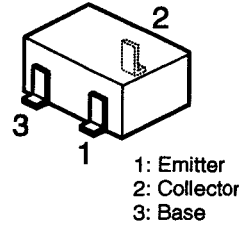

2SA1725 (O/P/Y)
2SC4495

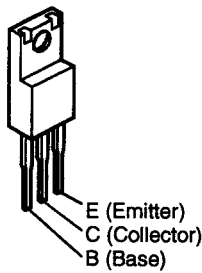

2SB1328 (Q)
2SD2004 (Q)

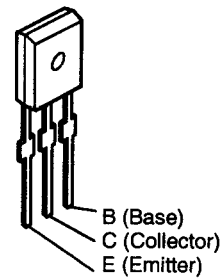

● DIODES (included LED)

1SS270A

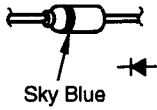

MTZJ3.3A MTZJ7.5A
MTZJ5.6A MTZJ9.1A
MTZJ6.2A MTZJ36A

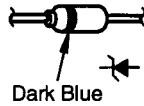

1SR35-200A

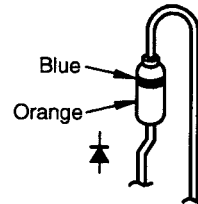

S4VB20
(PA: D518,519,520)

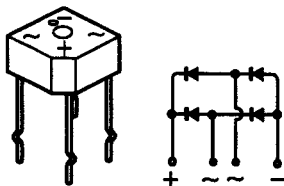

SEL1210S (Red)
(AU: LD103)
SEL1410E (Green)
(AU: LD101,110,111)

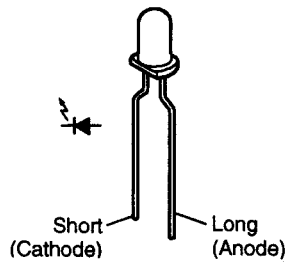

● OTHER
GP1U271X (Remote Control Sensor)
 (AU: IC101)

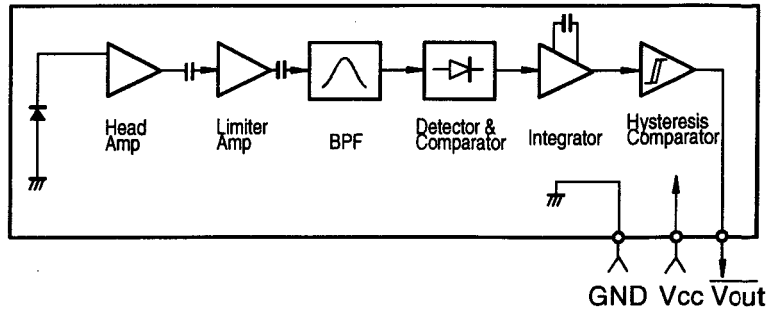
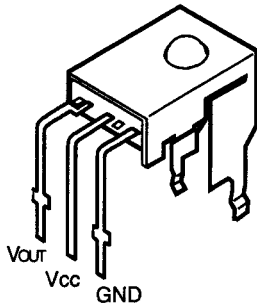

● FL DISPLAY FIP16FM7R (Part No.: 3934156001)(AU: FL101)

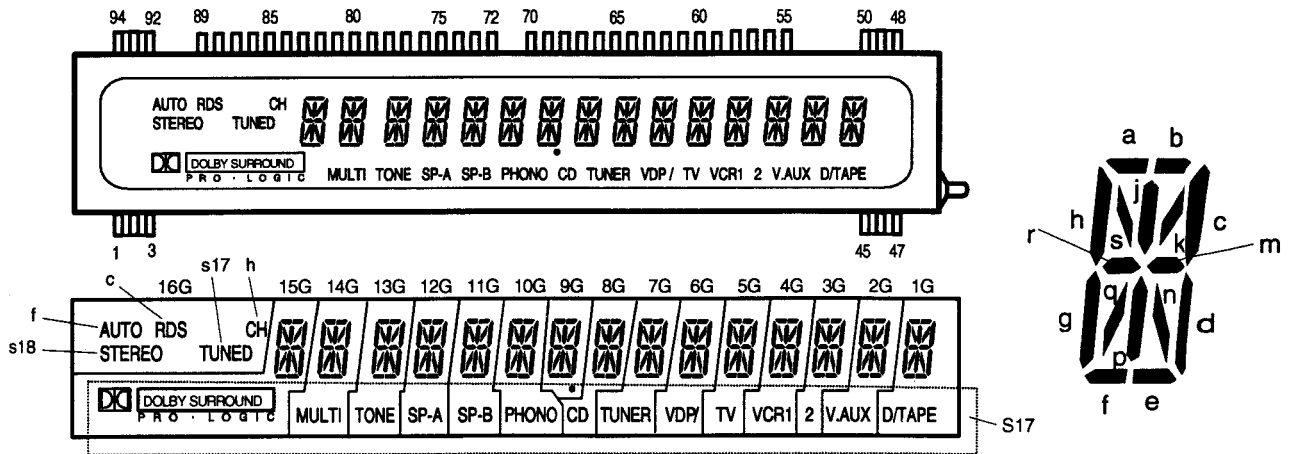

(UPPER)

TERMINAL No.	94	93	92	91	90	89	88	87	86	85	84	83	82	81								
ELECTRODE	F1	F1	F1	NP	NP	P	P	P	P	P	P	P	P	P								
						a	b	c	j	k	s	h	r	m								
TERMINAL No.	80	79	78	77	76	75	74	73	72	71	70	69	68	67	66	65	64	63	62	61		
ELECTRODE	P	P	P	P	P	P	P	P	P	NP	16G	15G	14G	13G	12G	11G	10G	9G	8G	7G		
	d	n	q	p	g	f	e	s17	s18													
TERMINAL No.										60	59	58	57	56	55	54	53	52	51	50	49	48
ELECTRODE										6G	5G	4G	3G	2G	1G	NP	NP	NP	NP	F2	F2	F2

(LOWER)

TERMINAL No.										35	36	37	38	39	40	41	42	43	44	45	46	47
ELECTRODE										NP	NP	NP	NP	NP	NP	NP	NP	NP	NP	F2	F2	F2
TERMINAL No.	15	16	17	18	19	20	21	22	23	24	25	26	27	28	29	30	31	32	33	34		
ELECTRODE	NP	NP	NP	NP	NP	NP	NP	NP	NP	NP	NP	NP	NP	NP	NP	NP	NP	NP	NP	NP	NP	NP
TERMINAL No.	1	2	3	4	5	6	7	8	9	10	11	12	13	14								
ELECTRODE	F1	F1	F1	NP	NP	NP	NP	NP	NP	NP	NP	NP	NP	NP								

Notes: F: Filament G: Grid A: Anode NP: No Pin

PRINTED WIRING BOARD

1U-3063

1 2 3 4 5 6 7 8

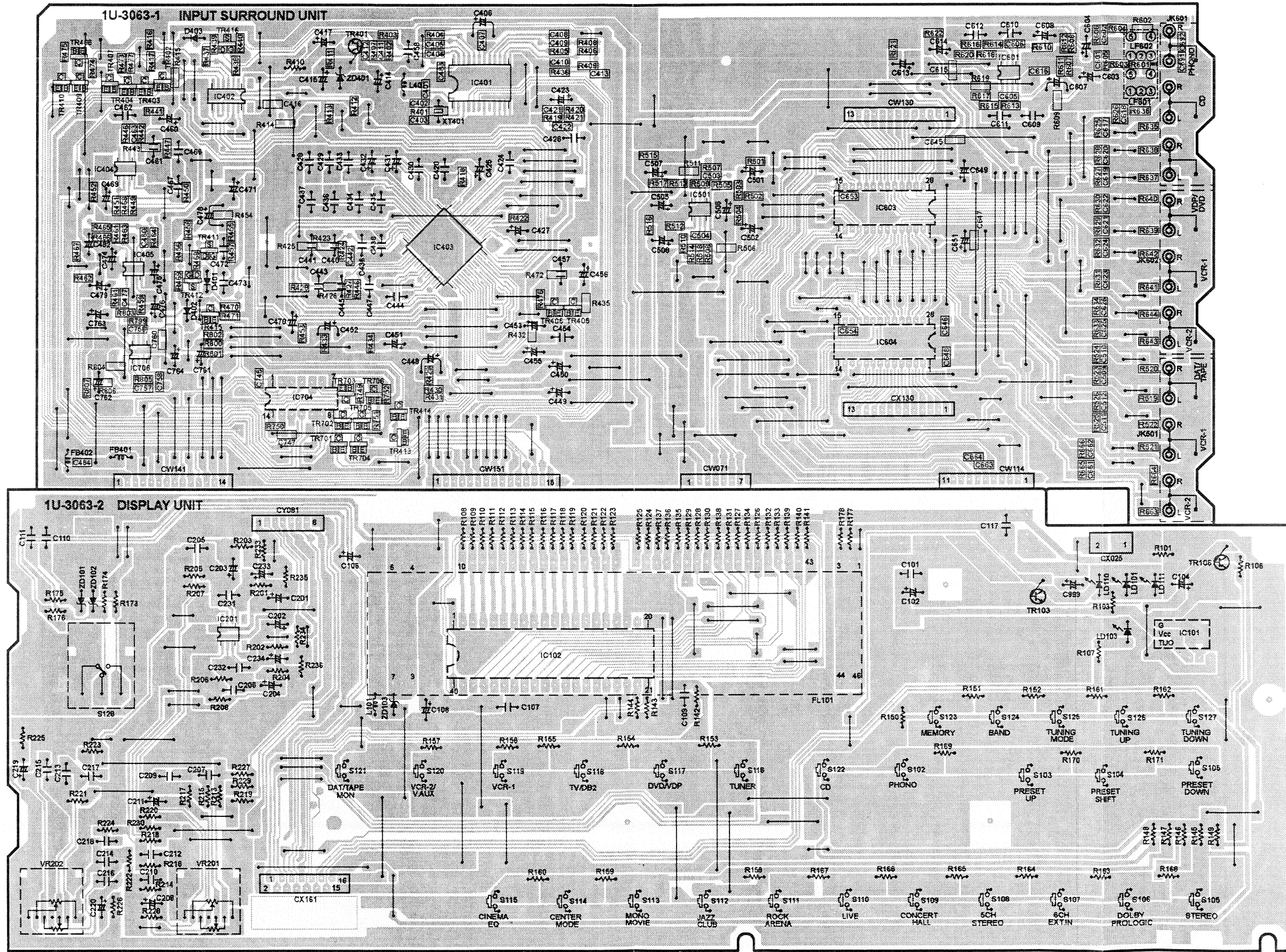

A
B
C
D
E

1

2

3

4

5

6

7

8

1U-3064

A

B

C

D

E

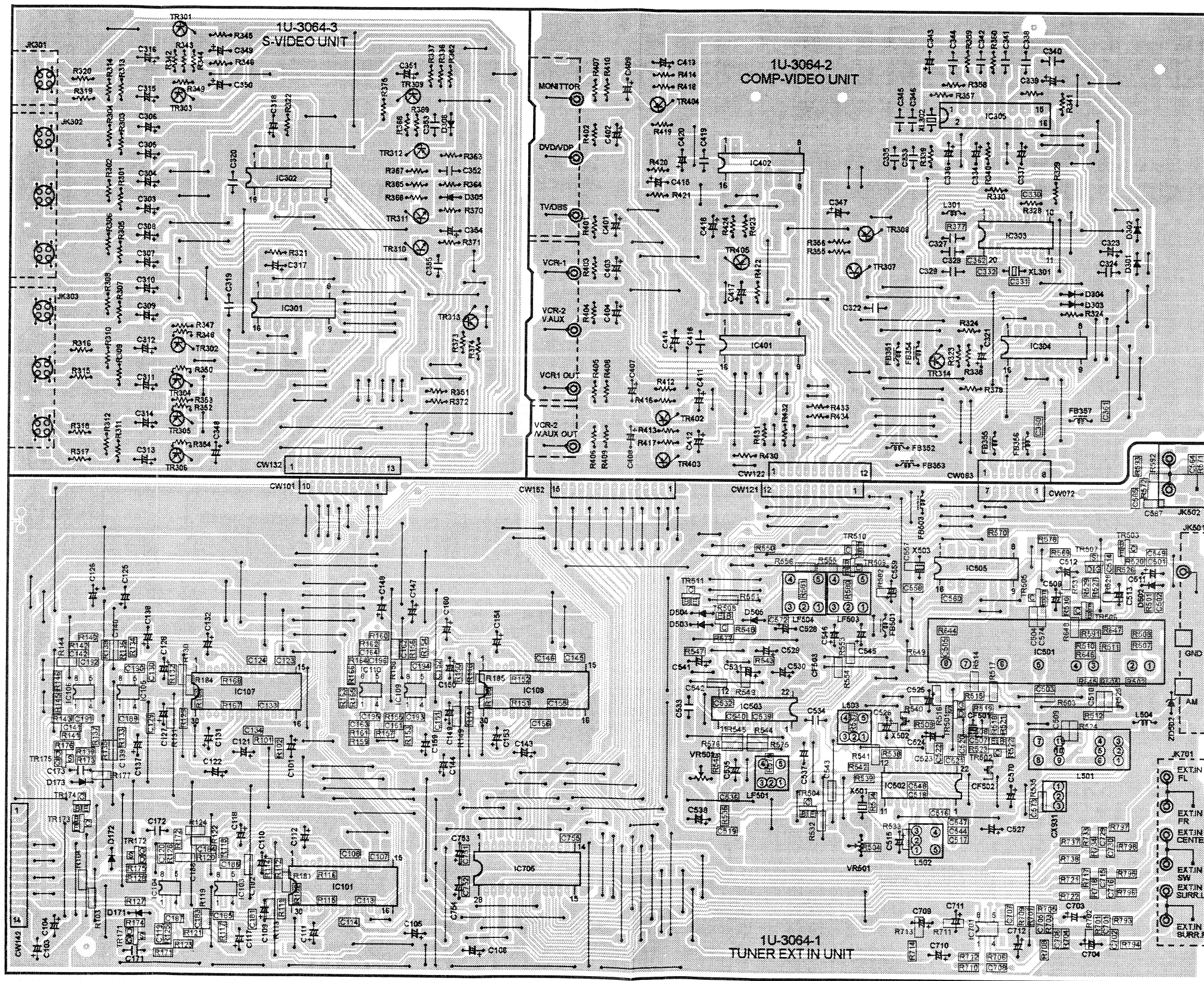

1U-3065

1 2 3 4 5 6 7 8

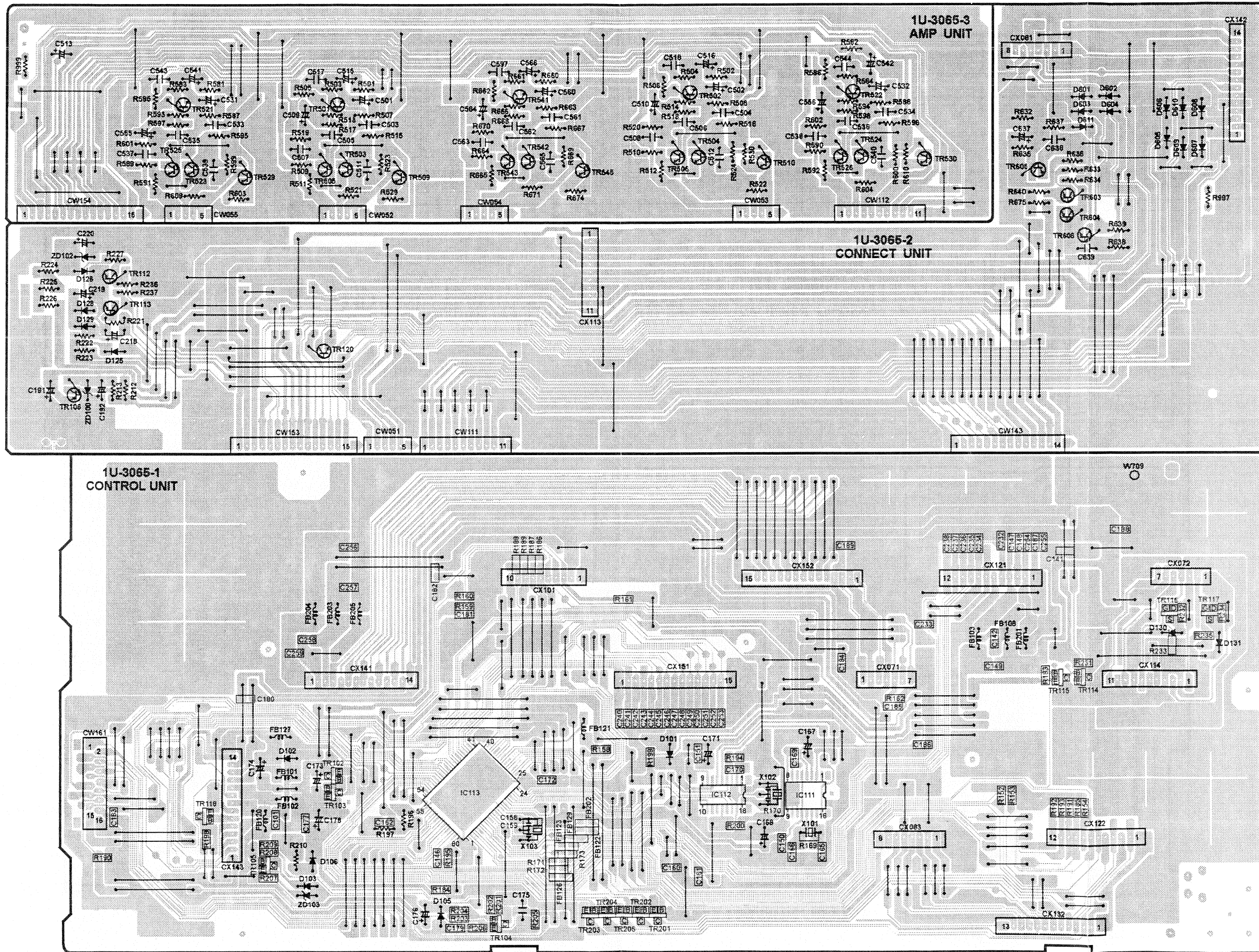

A

B

C

D

E

1U-3066

1 2 3 4 5 6 7 8

A

B

C

D

E

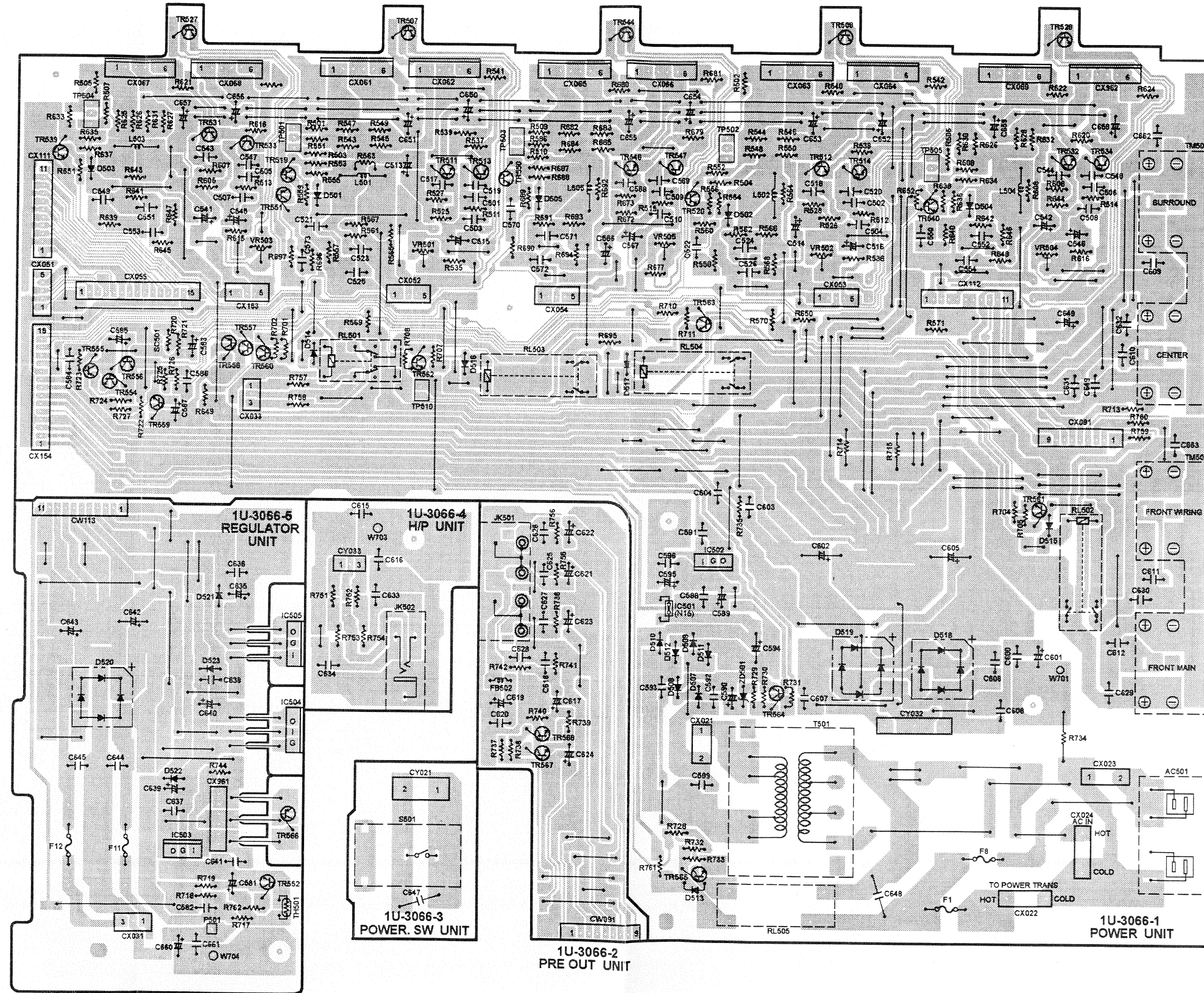

NOTE FOR PARTS LIST

- Part indicated with the mark "⊙" are not always in stock and possibly to take a long period of time for supplying, or in some case supplying of part may be refused.
- When ordering of part, clearly indicate "1" and "I" (I) to avoid mis-supplying.
- Ordering part without stating its part number can not be supplied.
- Part indicated with the mark "★" is not illustrated in the exploded view.
- Not including Carbon Film ±5%, 1/4W Type in the P.W.Board parts list. (Refer to the Schematic Diagram for those parts.)

WARNING:

Parts marked with this symbol  have critical characteristics.
Use ONLY replacement parts recommended by the manufacturer.

● **Resistors**

Ex.: **RN 14K 2E 182 G FR**
 Type Shape Power Resist- Allowable Others
 and per- ance error
 formance

RD : Carbon	2B : 1/8W	F : ±1%	P : Pulse-resistant type
RC : Composition	2E : 1/4W	G : ±2%	NL : Low noise type
RS : Metal oxide film	2H : 1/2W	J : ±5%	NB : Non-burning type
RW : Winding	3A : 1W	K : ±10%	FR : Fuse-resistor
RN : Metal film	3D : 2W	M : ±20%	F : Lead wire forming
RK : Metal mixture	3F : 3W		
	3H : 5W		

* **Resistance**

$\overset{1}{\text{R}}\overset{2}{\text{R}} \Rightarrow 1800 \text{ ohm} = 1.8 \text{ kohm}$
 Indicates number of zeros after effective number.
 2-digit effective number.

• Units: ohm

$\overset{1}{\text{R}}\overset{2}{\text{R}} \Rightarrow 1.2 \text{ ohm}$
 1-digit effective number.
 2-digit effective number, decimal point indicated by R.

• Units: ohm

● **Capacitors**

Ex.: **CE 04W 1H 2R2 M BP**
 Type Shape Dielectric Capacity Allowable Others
 and per- strength error
 formance

CE : Aluminum foil electrolytic	0J : 6.3V	F : ±1%	HS : High stability type
CA : Aluminum solid electrolytic	1A : 10V	G : ±2%	BP : Non-polar type
CS : Tantalum electrolytic	1C : 16V	J : ±5%	HR : Ripple-resistant type
CO : Film	1E : 25V	K : ±10%	DL : For change and discharge
CK : Ceramic	1V : 35V	M : ±20%	HF : For assuring high frequency
CC : Ceramic	1H : 50V	Z : +80%	U : UL part
CP : Oil	2A : 100V	-20%	C : CSA part
CM : Mica	2B : 125V	P : +100%	W : UL-CSA type
CF : Metallized	2C : 160V	-0%	F : Lead wire forming
CH : Metallized	2D : 200V	C : ±0.25pF	
	2E : 250V	D : ±0.5pF	
	2H : 500V	= : Others	
	2J : 630V		

* **Capacity (electrolyte only)**

$\overset{2}{\text{R}}\overset{2}{\text{R}} \Rightarrow 2200\mu\text{F}$
 Indicates number of zeros after effective number.
 2-digit effective number.

• Units: μF .

$\overset{2}{\text{R}}\overset{2}{\text{R}} \Rightarrow 2.2\mu\text{F}$
 1-digit effective number.
 2-digit effective number, decimal point indicated by R.

• Units: μF .

* **Capacity (except electrolyte)**

$\overset{2}{\text{R}}\overset{2}{\text{R}} \Rightarrow 2200\text{pF} = 0.0022\mu\text{F}$
 (More than 2) — Indicates number of zeros after effective number.
 2-digit effective number.

• Units: μF .

$\overset{2}{\text{R}}\overset{2}{\text{R}}\overset{1}{\text{R}} \Rightarrow 220\text{pF}$
 (0 or 1) — Indicates number of zeros after effective number.
 2-digit effective number.

• Units: pF.

• When the dielectric strength is indicated in AC, "AC" is included after the dielectric strength value.

PARTS LIST OF P.W.B. UNIT ASS'Y 1U-3063 AUDIO IN DISP UNIT ASS'Y

Ref. No.	Part No.	Part Name	Remarks	Ref. No.	Part No.	Part Name	Remarks
SEMICONDUCTORS GROUP				R419	247 0009 969	Carbon chip 8.2 kohm 1/10W	RM73B--822J
IC101	499 0290 007	Remocon sensor GP1U271X		R420,421	247 0010 929	Carbon chip 15 kohm 1/10W	RM73B--153J
IC102	262 2035 008	IC MSC1937-03RS		R422	247 0019 988	Carbon chip 100 kohm 1/10W	RM73B--104F
IC201	263 0896 909	IC NJM2068MD		R423	247 0009 956	Carbon chip 7.5 kohm 1/10W	RM73B--752J
IC401	262 2342 005	IC NJU9702G		R424	247 0011 944	Carbon chip 47 kohm 1/10W	RM73B--473J
IC402	262 1875 900	IC BU4066BCF		R425	247 0010 929	Carbon chip 15 kohm 1/10W	RM73B--153J
IC403	263 0938 003	IC DDSC-A		R426	247 0009 956	Carbon chip 7.5 kohm 1/10W	RM73B--752J
IC404,405	263 0615 902	IC BA15218F		R427	247 0011 944	Carbon chip 47 kohm 1/10W	RM73B--473J
IC501	263 0896 909	IC NJM2068MD		R428	247 0010 929	Carbon chip 15 kohm 1/10W	RM73B--153J
IC601	263 0896 909	IC NJM2068MD		R429	247 0016 923	Carbon chip 4.7 Mohm 1/10W	RM73B--475K
IC603	262 2034 009	IC TC9273N-007		R430,431	247 0011 960	Carbon chip 56 kohm 1/10W	RM73B--563J
IC704	263 0359 006	IC LC4966		R432	247 0012 927	Carbon chip 100 kohm 1/10W	RM73B--104J
IC706	263 0615 902	IC BA15218F		R433,434	247 0011 944	Carbon chip 47 kohm 1/10W	RM73B--473J
TR103	269 0020 906	Transistor DTC114ES(10K-10K)		R435	247 0012 927	Carbon chip 100 kohm 1/10W	RM73B--104J
TR106	269 0046 906	Transistor DTA114ES(10K-10K)		R441,442	247 0009 985	Carbon chip 10 kohm 1/10W	RM73B--103J
TR401	274 0169 908	Transistor 2SD1292(R)		R443	247 0013 984	Carbon chip 470 kohm 1/10W	RM73B--474J
TR402-406	269 0054 901	Transistor DTC144EK		R446	247 0007 945	Carbon chip 1 kohm 1/10W	RM73B--102J
TR701	269 0054 901	Transistor DTC144EK		R447	247 0009 901	Carbon chip 4.7 kohm 1/10W	RM73B--472J
TR702	269 0055 900	Transistor DTA144EK		R449	247 0009 969	Carbon chip 8.2 kohm 1/10W	RM73B--822J
TR703,704	269 0054 901	Transistor DTC144EK		R450	247 0008 986	Carbon chip 3.9 kohm 1/10W	RM73B--392J
TR705	269 0055 900	Transistor DTA144EK		R451	247 0005 905	Carbon chip 100 ohm 1/10W	RM73B--101J
TR706	269 0054 901	Transistor DTC144EK		R452	247 0012 927	Carbon chip 100 kohm 1/10W	RM73B--104J
LD101	393 9452 904	LED SEL1410E	Green	R453,454	247 0011 944	Carbon chip 47 kohm 1/10W	RM73B--473J
LD103	393 9434 906	LED SEL1210S	Red	R456	247 0005 905	Carbon chip 100 ohm 1/10W	RM73B--101J
LD110,111	393 9452 904	LED SEL1410E	Green	R459	247 0013 984	Carbon chip 470 kohm 1/10W	RM73B--474J
ZD101,102	276 0637 902	Zener diode MTZJ6.2A	6.2V	R461	247 0005 905	Carbon chip 100 ohm 1/10W	RM73B--101J
ZD103	276 0644 937	Zener diode MTZJ9.1A	9.1V	R462	247 0012 927	Carbon chip 100 kohm 1/10W	RM73B--104J
ZD401	276 0637 902	Zener diode MTZJ6.2A	6.2V	R463	247 0009 901	Carbon chip 4.7 kohm 1/10W	RM73B--472J
RESISTORS GROUP				R464	247 0018 905	Carbon chip 0 ohm 1/10W	RM73B--0R0K
R401	247 0014 967	Carbon chip 1 Mohm 1/10W	RM73B--105J	R465	247 0009 901	Carbon chip 4.7 kohm 1/10W	RM73B--472J
R402	247 0010 945	Carbon chip 18 kohm 1/10W	RM73B--183J	R466	247 0005 905	Carbon chip 100 ohm 1/10W	RM73B--101J
R403	247 0009 927	Carbon chip 5.6 kohm 1/10W	RM73B--562J	R467	247 0012 927	Carbon chip 100 kohm 1/10W	RM73B--104J
R404,405	247 0003 936	Carbon chip 20 ohm 1/10W	RM73B--200J	R472	247 0011 944	Carbon chip 47 kohm 1/10W	RM73B--473J
R406	247 0010 945	Carbon chip 13 kohm 1/10W	RM73B--183J	R476	247 0011 944	Carbon chip 47 kohm 1/10W	RM73B--473J
R407	247 0009 956	Carbon chip 7.5 kohm 1/10W	RM73B--752J	R477	247 0018 905	Carbon chip 0 ohm 1/10W	RM73B--0R0K
R408,409	247 0010 929	Carbon chip 15 kohm 1/10W	RM73B--153J	R501-504	247 0012 927	Carbon chip 100 kohm 1/10W	RM73B--104J
R410	241 2387 908	Carbon film 1 ohm 1/4W(NB)	RD14B2E010JNBS	R505,506	247 0005 905	Carbon chip 100 ohm 1/10W	RM73B--101J
R411	247 0007 945	Carbon chip 1 kohm 1/10W	RM73B--102J	R509,510	247 0018 905	Carbon chip 0 ohm 1/10W	RM73B--0R0K
R412-414	247 0009 969	Carbon chip 8.2 kohm 1/10W	RM73B--822J	R511-514	247 0005 905	Carbon chip 100 ohm 1/10W	RM73B--101J
R415-417	247 0011 944	Carbon chip 47 kohm 1/10W	RM73B--473J	R515-518	247 0012 927	Carbon chip 100 kohm 1/10W	RM73B--104J
R418	247 0013 942	Carbon chip 330 kohm 1/10W	RM73B--334J	R519-522	247 0006 962	Carbon chip 470 ohm 1/10W	RM73B--471J
				R523-526	247 0015 966	Carbon chip 2.7 Mohm 1/10W	RM73B--275J
				R601,602	247 0018 905	Carbon chip 0 ohm 1/10W	RM73B--0R0K
				R603,604	247 0006 946	Carbon chip 390 ohm 1/10W	RM73B--391J
				R605,606	247 0011 986	Carbon chip 68 kohm 1/10W	RM73B--683J
				R607,608	247 0012 969	Carbon chip 150 kohm 1/10W	RM73B--154J
				R609,610	247 0004 922	Carbon chip 47 ohm 1/10W	RM73B--470J
				R611,612	247 0005 992	Carbon chip 240 ohm 1/10W	RM73B--241J
				R613,614	247 0012 956	Carbon chip 130 kohm 1/10W	RM73B--134J
				R615,616	247 0009 998	Carbon chip 11 kohm 1/10W	RM73B--113J

Ref. No.	Part No.	Part Name	Remarks	Ref. No.	Part No.	Part Name	Remarks
R617,618	247 0003 949	Carbon chip 22 ohm 1/10W	RM73B--220J	C414	254 4252 930	Electrolytic 100 μ F/10V	CE04W1A101M
R619,620	247 0005 905	Carbon chip 100 ohm 1/10W	RM73B--101J	C415	254 4254 909	Electrolytic 10 μ F/16V	CE04W1C100M
R621,622	247 0011 944	Carbon chip 47 kohm 1/10W	RM73B--473J	C416	257 0014 935	Ceramic chip 0.1 μ F/25V	CK73F1E104Z
R625-634	247 0015 966	Carbon chip 2.7 Mohm 1/10W	RM73B--275J	C417	254 4260 948	Electrolytic 1 μ F/50V	CE04W1H010M
R635-644	247 0006 962	Carbon chip 470 ohm 1/10W	RM73B--471J	C418	256 1035 978	Metalized 0.68 μ F/50V	CF93A1H684J
R663,664	247 0006 962	Carbon chip 470 ohm 1/10W	RM73B--471J	C421	257 0009 924	Ceramic chip 2200 pF/50V	CK73B1H222K
R665,666	247 0015 966	Carbon chip 2.7 Mohm 1/10W	RM73B--275J	C422	257 0006 927	Ceramic chip 470 pF/50V	CC73SL1H471J
R749-752	247 0011 944	Carbon chip 47 kohm 1/10W	RM73B--473J	C423	254 4260 948	Electrolytic 1 μ F/50V	CE04W1H010M
R799-802	247 0010 961	Carbon chip 22 kohm 1/10W	RM73B--223J	C424	256 1034 937	Metallized 0.047 μ F/50V	CF93A1H473J
R803	247 0018 905	Carbon chip 0 ohm 1/10W	RM73B--0R0K	C425	254 4250 958	Electrolytic 470 μ F/6.3V	CE04W0J471M
R804,805	247 0009 901	Carbon chip 4.7 kohm 1/10W	RM73B--472J	C426	255 1264 995	Mylar film 5600 pF/50V	CQ93M1H562J(B)
R806	247 0005 905	Carbon chip 100 ohm 1/10W	RM73B--101J	C427	254 4254 941	Electrolytic 100 μ F/16V	CE04W1C101M
R807	247 0012 927	Carbon chip 100 kohm 1/10W	RM73B--104J	C428-430	256 1035 910	Metalized 0.22 μ F/16V	CF93A1H224J
VR201	211 0883 018	Variable resistor 30 kohm	V14P25FC303K	C431,432	254 4260 977	Electrolytic 4.7 μ F/50V	CE04W1H4R7M
VR202	211 0883 005	Variable resistor 10 kohm	V14P25FC103K	C433	256 1035 910	Metalized 0.22 μ F/16V	CF93A1H224J
CAPACITORS GROUP				C434-437	256 1034 979	Metalized 0.1 μ F/50V	CF93A1H104J
C101	253 9039 906	BC ceramic cap. 0.1 μ F/25V	CK45=1E104Z(DD-3)	C438,439	255 1265 978	Mylar film 0.022 μ F/50V	CQ93M1H223J(B)
C102	254 4260 948	Electrolytic 1 μ F/50V	CE04W1H010M	C440,441	256 1034 979	Metalized 0.1 μ F/50V	CF93A1H104J
C104	254 4196 944	Electrolytic 1 μ F/50V	CE04W1H010M(SRA)	C442	257 0006 969	Ceramic chip 680 pF/50V	CC73SL1H681J
C106	254 4261 921	Electrolytic 100 μ F/50V	CE04W1H101M	C443	256 1034 937	Metallized 0.047 μ F/50V	CF93A1H473J
C107	253 1181 904	Ceramic 0.01 μ F/50V	CK45F1H103Z(DD-3)	C444,445	256 1034 979	Metalized 0.1 μ F/50V	CF93A1H104J
C108	254 4250 945	Electrolytic 330 μ F/6.3V	CE04W0J331M	C446	257 0006 969	Ceramic chip 680 pF/50V	CC73SL1H681J
C109	253 1179 903	Ceramic 100 pF/50V	CK45B1H101K(DD-3)	C447	256 1034 937	Metallized 0.047 μ F/50V	CF93A1H473J
C110,111	253 1181 904	Ceramic 0.01 μ F/50V	CK45F1H103Z(DD-3)	C448	254 4254 912	Electrolytic 22 μ F/16V	CE04W1C220M
C117	256 1034 979	Metalized 0.1 μ F/50V	CF93A1H104J	C449-452	254 4254 909	Electrolytic 10 μ F/16V	CE04W1C100M
C201,202	254 4260 948	Electrolytic 1 μ F/50V	CE04W1H010M	C453	254 4254 912	Electrolytic 22 μ F/16V	CE04W1C220M
C203,204	254 4254 938	Electrolytic 47 μ F/16V	CE04W1C470M	C454	255 1264 982	Mylar film 4700 pF/50V	CQ93M1H472J(B)
C205,206	253 4537 924	Ceramic 33 pF/50V	C45SL1H330J(DD-3)	C455	254 4252 930	Electrolytic 100 μ F/10V	CE04W1A101M
C207,208	255 1264 940	Mylar film 2200 pF/50V	CQ93M1H222J(B)	C456	254 4254 909	Electrolytic 10 μ F/16V	CE04W1C100M
C209,210	256 1035 907	Metallized 0.18 μ F/50V	CF93A1H184J	C457	256 1035 910	Metallized 0.22 μ F/16V	CF93A1H224J
C211,212	254 4260 948	Electrolytic 1 μ F/50V	CE04W1H010M	C460	254 4254 909	Electrolytic 10 μ F/16V	CE04W1C100M
C215,216	255 1265 949	Mylar film 0.012 μ F/50V	CQ93M1H123J(B)	C461	255 1264 953	Mylar film 2700 pF/50V	CQ93M1H272J(B)
C217,218	256 1034 940	Metallized 0.056 μ F/50V	CF93A1H563J	C462	255 1264 995	Mylar film 5600 pF/50V	CQ93M1H562J(B)
C219,220	254 4260 922	Electrolytic 0.33 μ F/50V	CE04W1HR33M	C466,467	256 1034 979	Metalized 0.1 μ F/50V	CF93A1H104J
C231,232	253 4538 949	Ceramic 100 pF/50V	C45SL1H101J(DD-3)	C469-471	254 4254 909	Electrolytic 10 μ F/16V	CE04W1C100M
C233,234	254 4260 980	Electrolytic 10 μ F/50V	CE04W1H100M	C474,475	254 4260 948	Electrolytic 1 μ F/50V	CE04W1H010M
C401	257 0014 935	Ceramic chip 0.1 μ F/25V	CK73F1E104Z	C476	254 4254 909	Electrolytic 10 μ F/16V	CE04W1C100M
C402,403	257 0005 944	Ceramic chip 220 pF/50V	CC73SL1H221J	C479	254 4254 909	Electrolytic 10 μ F/16V	CE04W1C100M
C404	257 0006 927	Ceramic chip 470 pF/50V	CC73SL1H471J	C481	257 0004 961	Ceramic chip 100 pF/50V	CC73SL1H101J
C405	257 0011 996	Ceramic chip 0.1 μ F/25V	CK73B1E104K	C482	254 4254 909	Electrolytic 10 μ F/16V	CE04W1C100M
C406	254 4254 938	Electrolytic 47 μ F/16V	CE04W1C470M	C483	257 0014 935	Ceramic chip 0.1 μ F/25V	CK73F1E104Z
C407,408	257 0011 983	Ceramic chip 0.047 μ F/25V	CK73B1E473K	C484	257 0008 983	Ceramic chip 1000 pF/50V	CK73B1H102K
C409	257 0011 996	Ceramic chip 0.1 μ F/25V	CK73B1E104K	C501,502	254 4254 909	Electrolytic 10 μ F/16V	CE04W1C100M
C410	257 0006 927	Ceramic chip 470 pF/50V	CC73SL1H471J	C505,506	254 4260 948	Electrolytic 1 μ F/50V	CE04W1H010M
C411,412	257 0009 979	Ceramic chip 5600 pF/50V	CK73B1H562K	C507,508	254 4254 941	Electrolytic 100 μ F/16V	CE04W1C101M
C413	257 0009 940	Ceramic chip 3300 pF/50V	CK73B1H332K	C509-512	257 0004 961	Ceramic chip 100 pF/50V	CC73SL1H101J
				C601,602	257 0005 944	Ceramic chip 220 pF/50V	CC73SL1H221J
				C603,604	254 4254 909	Electrolytic 10 μ F/16V	CE04W1C100M
				C605,606	257 0004 961	Ceramic chip 100 pF/50V	CC73SL1H101J
				C607,608	254 4250 932	Electrolytic 220 μ F/6.3V	CE04W0J221M

**PARTS LIST OF P.W.B. UNIT ASS'Y
1U-3064 TU VR VIDEO UNIT ASS'Y**

Ref. No.	Part No.	Part Name	Remarks
C609,610	255 4199 999	Mylar film 0.024 μF/50V	Q92M1H243J(MRZ)
C611,612	255 1265 907	Mylar film 6800 pF/50V	CQ93M1H682J(B)
C613,614	254 4254 938	Electrolytic 47 μF/16V	CE04W1C470M
C615,616	257 0012 982	Ceramic chip 0.022 μF/50V	CK73F1H223Z
C645	257 0012 966	Ceramic chip 0.01 μF/50V	CK73F1H103Z
C647	257 0012 966	Ceramic chip 0.01 μF/50V	CK73F1H103Z
C649	254 4260 977	Electrolytic 4.7 μF/50V	CE04W1H4R7M
C651	254 4260 977	Electrolytic 4.7 μF/50V	CE04W1H4R7M
C661,662	257 0004 961	Ceramic chip 100 pF/50V	CC73SL1H101J
C745	257 0012 966	Ceramic chip 0.01 μF/50V	CK73F1H103Z
C747	257 0012 966	Ceramic chip 0.01 μF/50V	CK73F1H103Z
C756-758	257 0004 961	Ceramic chip 100 pF/50V	CC73SL1H101J
C760	257 0004 961	Ceramic chip 100 pF/50V	CC73SL1H101J
C761,762	254 4260 980	Electrolytic 10 μF/50V	CE04W1H100M
C763,764	254 4260 948	Electrolytic 1 μF/50V	CE04W1H010M
C999	254 4260 948	Electrolytic 1 μF/50V	CE04W1H010M

OTHER PARTS GROUP

				Q'ty
CW071	205 0942 022	7P connector socket(TUC-P)		1
CW114	205 0885 066	11P connector socket (TUC-P)		1
CW141	205 0885 011	14P connector socket (TUC-P)		1
CW151	205 0885 040	15P connector socket (TUC-P)		1
CX025	205 0644 003	2P wrapping terminal		1
CX161	205 1055 028	16P connector base (TKC-V)		1
CY081	204 2446 015	8P PH-SAN cord		1
FB401,402	235 0049 900	Beads inductor		2
FL101	393 4156 001	FLD FIP16FM7R		1
JK501	204 8543 006	6 P pin jack		1
JK601,602	204 8543 006	6 P pin jack		2
L101	235 0060 989	Inductor 120 μH		1
L401	235 0060 989	Inductor 120 μH		1
S101~114	212 5604 910	Tact switch -TA (ALPS)		16
S116~127	212 5604 910	Tact switch -TA (ALPS)		14
S128	212 0373 000	Rotary encorder EC16B		1
XT401	399 0223 907	Ceramic 2.00 MHz	CSA2.00MG-TF01	1

SEMICONDUCTORS GROUP

Ref. No.	Part No.	Part Name	Remarks
IC101	262 2214 007	IC LC7536	
IC103,104	263 0896 909	IC NJM2068MD	
IC105,106	263 0615 902	IC BA15218F	
IC107,108	262 2214 007	IC LC7536	
IC109,110	263 0615 902	IC BA15218F	
IC401	263 0856 004	IC BA7625	
IC501	216 0102 008	Front end	
IC502	263 0891 001	IC LA1265(S)	
IC503	263 0439 007	IC LA3401	
IC505	262 2348 009	IC LM7001JU	
IC701	263 0896 909	IC NJM2068MD	
IC705	262 2397 005	IC NJU7312AL	
TR402-404	271 0290 904	Transistor 2PA1015GR	
TR502	273 0411 909	Transistor 2SC2996-Y	
TR503,504	269 0083 901	Transistor DTA114EK	
TR505	269 0114 906	Transistor RN2402	
TR506	273 0403 904	Transistor 2SC2712-Y/GR	
TR507	275 0094 908	FET 2SK209-GR	
TR508	269 0054 901	Transistor DTC144EK	
TR509,510	269 0066 902	Transistor DTC323TK	
TR511	269 0086 908	Transistor DTA114TK	
D501	276 0432 903	Diode 1SS270A	
D503~505	276 0432 903	Diode 1SS270A	
ZD502	276 0644 937	Zener diode MTZJ9.1A	9.1V

RESISTORS GROUP

R101	247 0009 901	Carbon chip 4.7 kohm 1/10W	RM73B--472J
R102	247 0008 960	Carbon chip 3.3 kohm 1/10W	RM73B--332J
R111,112	247 0011 944	Carbon chip 47 kohm 1/10W	RM73B--473J
R113,114	247 0013 900	Carbon chip 220 kohm 1/10W	RM73B--224J
R115,116	247 0011 944	Carbon chip 47 kohm 1/10W	RM73B--473J
R117,118	247 0005 905	Carbon chip 100 ohm 1/10W	RM73B--101J
R119,120	247 0012 927	Carbon chip 100 kohm 1/10W	RM73B--104J
R121,122	247 0005 905	Carbon chip 100 ohm 1/10W	RM73B--101J
R125,126	247 0018 905	Carbon chip 0 ohm 1/10W	RM73B--0R0K
R127,128	247 0005 905	Carbon chip 100 ohm 1/10W	RM73B--101J
R129,130	247 0011 944	Carbon chip 47 kohm 1/10W	RM73B--473J
R131,132	247 0013 900	Carbon chip 220 kohm 1/10W	RM73B--224J
R133,134	247 0005 905	Carbon chip 100 ohm 1/10W	RM73B--101J
R135,136	247 0012 927	Carbon chip 100 kohm 1/10W	RM73B--104J
R137,138	247 0005 905	Carbon chip 100 ohm 1/10W	RM73B--101J
R139,140	247 0007 916	Carbon chip 750 ohm 1/10W	RM73B--751J
R141	247 0009 901	Carbon chip 4.7 kohm 1/10W	RM73B--472J
R142	247 0009 914	Carbon chip 5.1 kohm 1/10W	RM73B--512J
R143,144	247 0005 905	Carbon chip 100 ohm 1/10W	RM73B--101J

Ref. No.	Part No.	Part Name	Remarks
R145,146	247 0012 927	Carbon chip 100 kohm 1/10W	RM73B--104J
R147,148	247 0011 944	Carbon chip 47 kohm 1/10W	RM73B--473J
R149,150	247 0013 900	Carbon chip 220 kohm 1/10W	RM73B--224J
R151,152	247 0011 944	Carbon chip 47 kohm 1/10W	RM73B--473J
R153,154	247 0005 905	Carbon chip 100 ohm 1/10W	RM73B--101J
R155,156	247 0012 927	Carbon chip 100 kohm 1/10W	RM73B--104J
R157,158	247 0005 905	Carbon chip 100 ohm 1/10W	RM73B--101J
R159,160	247 0007 916	Carbon chip 750 ohm 1/10W	RM73B--751J
R161,162	247 0009 901	Carbon chip 4.7 kohm 1/10W	RM73B--472J
R163,164	247 0005 905	Carbon chip 100 ohm 1/10W	RM73B--101J
R165,166	247 0012 927	Carbon chip 100 kohm 1/10W	RM73B--104J
R167,168	247 0011 944	Carbon chip 47 kohm 1/10W	RM73B--473J
R181-186	247 0018 905	Carbon chip 0 ohm 1/10W	RM73B--0R0K
R501	247 0002 966	Carbon chip 10 ohm 1/10W	RM73B--100J
R503	247 0007 945	Carbon chip 1 kohm 1/10W	RM73B--102J
R504,505	247 0018 905	Carbon chip 0 ohm 1/10W	RM73B--0R0K
R507-512	247 0018 905	Carbon chip 0 ohm 1/10W	RM73B--0R0K
R514,515	247 0005 905	Carbon chip 100 ohm 1/10W	RM73B--101J
R516	247 0007 945	Carbon chip 1 kohm 1/10W	RM73B--102J
R518	247 0005 989	Carbon chip 220 ohm 1/10W	RM73B--221J
R519	247 0006 962	Carbon chip 470 ohm 1/10W	RM73B--471J
R520	247 0007 945	Carbon chip 1 kohm 1/10W	RM73B--102J
R521	247 0009 901	Carbon chip 4.7 kohm 1/10W	RM73B--472J
R522	247 0006 920	Carbon chip 330 ohm 1/10W	RM73B--331J
R523	247 0007 961	Carbon chip 1.2 kohm 1/10W	RM73B--122J
R524,525	247 0012 927	Carbon chip 100 kohm 1/10W	RM73B--104J
R526	247 0005 905	Carbon chip 100 ohm 1/10W	RM73B--101J
R527	247 0009 969	Carbon chip 8.2 kohm 1/10W	RM73B--822J
R528	247 0008 986	Carbon chip 3.9 kohm 1/10W	RM73B--392J
R529	247 0006 946	Carbon chip 390 ohm 1/10W	RM73B--391J
R530	247 0005 947	Carbon chip 150 ohm 1/10W	RM73B--151J
R531	247 0018 905	Carbon chip 0 ohm 1/10W	RM73B--0R0K
R532	247 0005 921	Carbon chip 120 ohm 1/10W	RM73B--121J
R533	247 0010 929	Carbon chip 15 kohm 1/10W	RM73B--153J
R534	247 0005 921	Carbon chip 120 ohm 1/10W	RM73B--121J
R535	247 0010 945	Carbon chip 18 kohm 1/10W	RM73B--183J
R536	247 0018 905	Carbon chip 0 ohm 1/10W	RM73B--0R0K
R537	247 0011 986	Carbon chip 68 kohm 1/10W	RM73B--683J
R538	247 0009 943	Carbon chip 6.8 kohm 1/10W	RM73B--682J
R539	247 0009 927	Carbon chip 5.6 kohm 1/10W	RM73B--562J
R540,541	247 0009 985	Carbon chip 10 kohm 1/10W	RM73B--103J
R542,543	247 0008 960	Carbon chip 3.3 kohm 1/10W	RM73B--332J
R544,545	247 0012 927	Carbon chip 100 kohm 1/10W	RM73B--104J
R546	247 0011 973	Carbon chip 62 kohm 1/10W	RM73B--623J
R547	247 0012 927	Carbon chip 100 kohm 1/10W	RM73B--104J
R548	247 0009 985	Carbon chip 10 kohm 1/10W	RM73B--103J
R549	247 0012 927	Carbon chip 100 kohm 1/10W	RM73B--104J
R550	247 0009 927	Carbon chip 5.6 kohm 1/10W	RM73B--562J
R551	247 0009 985	Carbon chip 10 kohm 1/10W	RM73B--103J
R553,554	247 0008 960	Carbon chip 3.3 kohm 1/10W	RM73B--332J
R555,556	247 0009 927	Carbon chip 5.6 kohm 1/10W	RM73B--562J

Ref. No.	Part No.	Part Name	Remarks
R569	247 0009 985	Carbon chip 10 kohm 1/10W	RM73B--103J
R571,572	247 0015 966	Carbon chip 2.7 Mohm 1/10W	RM73B--275J
R575,576	247 0012 943	Carbon chip 120 kohm 1/10W	RM73B--124J
R577	247 0010 961	Carbon chip 22 kohm 1/10W	RM73B--223J
R578-581	247 0018 905	Carbon chip 0 ohm 1/10W	RM73B--0R0K
R582	247 0002 966	Carbon chip 10 ohm 1/10W	RM73B--100J
R592,593	247 0006 962	Carbon chip 470 ohm 1/10W	RM73B--471J
R644	247 0018 905	Carbon chip 0 ohm 1/10W	RM73B--0R0K
R647-649	247 0018 905	Carbon chip 0 ohm 1/10W	RM73B--0R0K
R701,702	247 0011 973	Carbon chip 62 kohm 1/10W	RM73B--623J
R703,704	247 0012 998	Carbon chip 200 kohm 1/10W	RM73B--204J
R705,706	247 0006 962	Carbon chip 470 ohm 1/10W	RM73B--471J
R709,710	247 0018 905	Carbon chip 0 ohm 1/10W	RM73B--0R0K
R711,712	247 0005 905	Carbon chip 100 ohm 1/10W	RM73B--101J
R713,714	247 0012 927	Carbon chip 100 kohm 1/10W	RM73B--104J
R717,718	247 0015 966	Carbon chip 2.7 Mohm 1/10W	RM73B--275J
R721,722	247 0006 962	Carbon chip 470 ohm 1/10W	RM73B--471J
R733,734	247 0015 966	Carbon chip 2.7 Mohm 1/10W	RM73B--275J
R737,738	247 0006 962	Carbon chip 470 ohm 1/10W	RM73B--471J
R793-798	247 0018 905	Carbon chip 0 ohm 1/10W	RM73B--0R0K
VR501	211 6093 941	Semi fixed resistor 10 kohm	V06PB103
VR502	211 6093 970	Semi fixed resistor 100 kohm	V06PB104

CAPACITORS GROUP

C103	254 4260 977	Electrolytic 4.7 μ F/50V	CE04W1H4R7M
C104	254 4260 977	Electrolytic 4.7 μ F/50V	CE04W1H4R7M
C105,106	254 4260 980	Electrolytic 10 μ F/50V	CE04W1H100M
C107,108	257 0012 982	Ceramic chip 0.022 μ F/50V	CK73F1H223Z
C109-112	254 4260 980	Electrolytic 10 μ F/50V	CE04W1H100M
C114	257 0012 966	Ceramic chip 0.01 μ F/50V	CK73F1H103Z
C117,118	254 4260 980	Electrolytic 10 μ F/50V	CE04W1H100M
C121,122	254 4254 909	Electrolytic 10 μ F/16V	CE04W1C100M
C123,124	257 0012 982	Ceramic chip 0.022 μ F/50V	CK73F1H223Z
C125,126	254 4260 948	Electrolytic 1 μ F/50V	CE04W1H010M
C127,128	254 4254 909	Electrolytic 10 μ F/16V	CE04W1C100M
C131,132	254 4254 909	Electrolytic 10 μ F/16V	CE04W1C100M
C134	257 0012 966	Ceramic chip 0.01 μ F/50V	CK73F1H103Z
C137,138	254 4254 909	Electrolytic 10 μ F/16V	CE04W1C100M
C141,142	257 0004 961	Ceramic chip 100 pF/50V	CC73SL1H101J
C143,144	254 4254 909	Electrolytic 10 μ F/16V	CE04W1C100M
C145,146	257 0012 982	Ceramic chip 0.022 μ F/50V	CK73F1H223Z
C147,148	254 4260 948	Electrolytic 1 μ F/50V	CE04W1H010M
C149,150	254 4254 909	Electrolytic 10 μ F/16V	CE04W1C100M
C153,154	254 4254 909	Electrolytic 10 μ F/16V	CE04W1C100M
C156	257 0012 966	Ceramic chip 0.01 μ F/50V	CK73F1H103Z
C159,160	254 4254 909	Electrolytic 10 μ F/16V	CE04W1C100M
C163,164	257 0004 961	Ceramic chip 100 pF/50V	CC73SL1H101J
C401-404	254 4260 977	Electrolytic 4.7 μ F/50V	CE04W1H4R7M

Ref. No.	Part No.	Part Name	Remarks	Ref. No.	Part No.	Part Name	Remarks	Q'ty
C407~409	254 4250 958	Electrolytic 470 μ F/6.3V	CE04W0J471M	OTHER PARTS GROUP				
C411	254 4254 909	Electrolytic 10 μ F/16V	CE04W1C100M	CF501	261 0135 907	Ceramic filter MA8		1
C413	254 4254 909	Electrolytic 10 μ F/16V	CE04W1C100M	CF502	261 0136 906	Ceramic filter MS2G		1
C415	254 4252 930	Electrolytic 100 μ F/10V	CE04W1A101M	CF503	261 0079 005	Ceramic resonator CSB456F11		1
C416	253 1181 917	Ceramic 0.022 μ F/50V	CK45F1H223Z(DD-3)	CW072	205 0942 022	7P connector socket(TUC-P)		1
C417	254 4260 948	Electrolytic 1 μ F/50V	CE04W1H010M	CW083	205 0885 095	8P connector socket (TUC-P)		1
C501,502	257 0008 983	Ceramic chip 1000 pF/50V	CK73B1H102K	CW101	205 0885 053	10P connector socket (TUC-P)		1
C503~505	257 0010 900	Ceramic chip 0.01 μ F/50V	CK73B1H103K	CW121,122	205 0885 079	12P connector socket (TUC-P)		2
C507,508	257 0010 900	Ceramic chip 0.01 μ F/50V	CK73B1H103K	CW142	205 0885 011	14P connector socket (TUC-P)		1
C509	257 0002 947	Ceramic chip 12 pF/50V	CC73SL1H120J	CW152	205 0885 040	15P connector socket (TUC-P)		1
C510	257 0010 900	Ceramic chip 0.01 μ F/50V	CK73B1H103K	CX931	205 0190 036	3P NH connector base		1
C511	254 4260 906	Electrolytic 0.1 μ F/50V	CE04W1H0R1M	FB501	235 0049 900	Beads inductor		1
C512	254 4254 938	Electrolytic 47 μ F/16V	CE04W1C470M	JK401,402	204 8516 017	3P pin jack		2
C513	254 3056 917	Electrolytic 1 μ F/50V	CE04D1H010MBP	JK403	204 8512 008	1P pin jack		1
C514	257 0010 942	Ceramic chip 0.022 μ F/50V	CK73B1H223K	JK501	205 0847 004	3P antenna terminal (PAL/F)		1
C515	254 4254 938	Electrolytic 47 μ F/16V	CE04W1C470M	JK502	204 8562 003	2P pin jack (S-GND)		1
C516,517	257 0010 900	Ceramic chip 0.01 μ F/50V	CK73B1H103K	JK701	204 8513 010	6P pin jack (S-GND)		1
C520	257 0004 961	Ceramic chip 100 pF/50V	CC73SL1H101J	L501	231 2096 001	MW ant.-osc. coil		1
C521~523	257 0010 900	Ceramic chip 0.01 μ F/50V	CK73B1H103K	L502	231 2085 009	FM det. trans.		1
C524	254 4260 935	Electrolytic 0.47 μ F/50V	CE04W1HR47M	L503	231 1138 009	AM IFT		1
C525	254 4260 980	Electrolytic 10 μ F/50V	CE04W1H100M	L504	235 0060 905	Inductor 2.2 μ H		1
C526	257 0010 942	Ceramic chip 0.022 μ F/50V	CK73B1H223K	X501	261 0031 001	Ceramic filter BFU450C4		1
C527	254 4260 948	Electrolytic 1 μ F/50V	CE04W1H010M	X502	261 0116 007	Ceramic filter SFU450B3		1
C528	254 4254 938	Electrolytic 47 μ F/16V	CE04W1C470M	X503	399 0075 003	Crystal 7.2 MHz		1
C529	254 4260 948	Electrolytic 1 μ F/50V	CE04W1H010M		001 0066 034	Earth wire	for TUNER	1
C530	254 4260 919	Electrolytic 0.22 μ F/50V	CE04W1HR22M		203 0312 009	AMISEN ass'y	for TUNER	1
C531	254 4260 948	Electrolytic 1 μ F/50V	CE04W1H010M					
C532	257 0010 900	Ceramic chip 0.01 μ F/50V	CK73B1H103K					
C533	256 1034 937	Metallized 0.047 μ F/50V	CF93A1H473J					
C534	256 1034 940	Metallized 0.056 μ F/50V	CF93A1H563J					
C535	254 3053 910	Electrolytic 22 μ F/16V	CE04D1C220MBP					
C536	257 0004 961	Ceramic chip 100 pF/50V	CC73SL1H101J					
C538	254 4254 912	Electrolytic 22 μ F/16V	CE04W1C220M					
C539,540	257 0006 972	Ceramic chip 750 pF/50V	CC73SL1H751J					
C541	254 4260 951	Electrolytic 2.2 μ F/50V	CE04W1H2R2M					
C544	257 0010 900	Ceramic chip 0.01 μ F/50V	CK73B1H103K					
C545,546	254 4254 909	Electrolytic 10 μ F/16V	CE04W1C100M					
C557,558	257 0002 976	Ceramic chip 16 pF/50V	CC73SL1H160J					
C559	254 4260 948	Electrolytic 1 μ F/50V	CE04W1H010M					
C560	257 0010 900	Ceramic chip 0.01 μ F/50V	CK73B1H103K					
C570	254 4254 909	Electrolytic 10 μ F/16V	CE04W1C100M					
C571	254 4260 948	Electrolytic 1 μ F/50V	CE04W1H010M					
C574	257 0004 961	Ceramic chip 100 pF/50V	CC73SL1H101J					
C587	257 0014 935	Ceramic chip 0.1 μ F/25V	CK73F1E104Z					
C703,704	254 4260 980	Electrolytic 10 μ F/50V	CE04W1H100M					
C705,706	257 0004 961	Ceramic chip 100 pF/50V	CC73SL1H101J					
C709,710	254 4260 980	Electrolytic 10 μ F/50V	CE04W1H100M					
C711,712	254 4260 977	Electrolytic 4.7 μ F/50V	CE04W1H4R7M					
C751,752	257 0012 966	Ceramic chip 0.01 μ F/50V	CK73F1H103Z					
C753,754	254 4260 977	Electrolytic 4.7 μ F/50V	CE04W1H4R7M					

PARTS LIST OF P.W.B. UNIT ASS'Y

1U-3065 CONTROL POWER UNIT ASS'Y

Ref. No.	Part No.	Part Name	Remarks	Ref. No.	Part No.	Part Name	Remarks
SEMICONDUCTORS GROUP				CAPACITORS GROUP			
IC113	262 2429 009	IC TMP87CS71F-6631		R195	247 0018 905	Carbon chip 0 ohm 1/10W	RM73B--0R0K
TR102	269 0083 901	Transistor DTA114EK		R198,199	247 0009 985	Carbon chip 10 kohm 1/10W	RM73B--103J
TR103	269 0054 901	Transistor DTC144EK		R201	247 0009 985	Carbon chip 10 kohm 1/10W	RM73B--103J
TR104	274 0163 904	Transistor 2SD601A		R202	247 0013 900	Carbon chip 220 kohm 1/10W	RM73B--224J
TR105	269 0054 901	Transistor DTC144EK		R203	247 0009 985	Carbon chip 10 kohm 1/10W	RM73B--103J
TR106	271 0131 924	Transistor 2SA988(E/F)		R204	247 0009 901	Carbon chip 4.7 kohm 1/10W	RM73B--472J
TR112,113	269 0046 906	Transistor DTA114ES(10K-10K)		R205	247 0009 985	Carbon chip 10 kohm 1/10W	RM73B--103J
TR114	269 0054 901	Transistor DTC144EK		R206	247 0009 901	Carbon chip 4.7 kohm 1/10W	RM73B--472J
TR115	269 0055 900	Transistor DTA144EK		R207-209	247 0007 945	Carbon chip 1 kohm 1/10W	RM73B--102J
TR116,117	275 0094 908	FET 2SK209-GR		R210,212	241 2387 940	Carbon film 4.7 ohm 1/4W(NB)	RD14B2E4R7JNBS
TR118	269 0055 900	Transistor DTA144EK		R224-226	244 2055 996	Metal oxide 1.2 kohm 1W	S14B3A122JNBS(S)
TR120	269 0020 906	Transistor DTC114ES(10K-10K)		R231	247 0011 944	Carbon chip 47 kohm 1/10W	RM73B--473J
TR201-205	269 0054 901	Transistor DTC144EK		R529,530	241 2376 964	Carbon film 47 ohm 1/4W(NB)	RD14B2E470JNBS
TR501,502	273 0253 918	Transistor 2SC2878(A/B)		R609,610	241 2376 964	Carbon film 47 ohm 1/4W(NB)	RD14B2E470JNBS
TR503-506	271 0094 919	Transistor 2SA970(BL)		R674	241 2376 964	Carbon film 47 ohm 1/4W(NB)	RD14B2E470JNBS
TR509,510	273 0281 906	Transistor 2SC2705(O)/(Y)		RESISTORS GROUP			
TR521,522	273 0253 918	Transistor 2SC2878(A/B)		R158	247 0018 905	Carbon chip 0 ohm 1/10W	RM73B--0R0K
TR523-526	271 0094 919	Transistor 2SA970(BL)		R159-162	247 0009 901	Carbon chip 4.7 kohm 1/10W	RM73B--472J
TR529,530	273 0281 906	Transistor 2SC2705(O)/(Y)		R171-173	247 0007 945	Carbon chip 1 kohm 1/10W	RM73B--102J
TR541	273 0253 918	Transistor 2SC2878(A/B)		R186-189	247 0009 985	Carbon chip 10 kohm 1/10W	RM73B--103J
TR542,543	271 0094 919	Transistor 2SA970(BL)		R190	247 0012 927	Carbon chip 100 kohm 1/10W	RM73B--104J
TR545	273 0281 906	Transistor 2SC2705(O)/(Y)					
TR603,604	271 0131 924	Transistor 2SA988(E/F)					
TR605	273 0445 001	Transistor 2SC4495					
TR606	271 0131 924	Transistor 2SA988(E/F)					
D102	276 0553 905	Diode 1SR35-200A	36V	C101	257 0012 966	Ceramic chip 0.01 μ F/50V	CK73F1H103Z
D103	276 0432 903	Diode 1SS270A	5.6V	C142	257 0004 961	Ceramic chip 100 pF/50V	CC73SL1H101J
D105	276 0432 903	Diode 1SS270A	3.3V	C149	257 0008 983	Ceramic chip 1000 pF/50V	CK73B1H102K
D106	276 0553 905	Diode 1SR35-200A		C158,159	257 0004 903	Ceramic chip 56 pF/50V	CC73SL1H560J
D125,126	276 0553 905	Diode 1SR35-200A		C172	257 0014 935	Ceramic chip 0.1 μ F/25V	CK73F1E104Z
D128-131	276 0432 903	Diode 1SS270A		C173	254 4254 909	Electrolytic 10 μ F/16V	CE04W1C100M
D601-611	276 0432 903	Diode 1SS270A		C174	254 4250 932	Electrolytic 220 μ F/6.3V	CE04W0J221M
ZD100	276 0645 978	Zener diode MTZJ36A	36V	C175	256 1034 982	Metalized 0.12 μ F/50V	CF93A1H124J
ZD102	276 0643 996	Zener diode MTZJ5.6A	5.6V	C176	254 4258 905	Electrolytic 4.7 μ F/35V	CE04W1V4R7M
ZD103	276 0634 905	Zener diode MTZJ3.3A	3.3V	C177	257 0012 966	Ceramic chip 0.01 μ F/50V	CK73F1H103Z
				C178	259 0007 702	Back up cap. 8200 μ F/5.5V	SB CAP==822=C
				C179	257 0012 966	Ceramic chip 0.01 μ F/50V	CK73F1H103Z
				C181	257 0006 927	Ceramic chip 470 pF/50V	CC73SL1H471J
				C183-189	257 0008 983	Ceramic chip 1000 pF/50V	CK73B1H102K
				C191,192	254 4260 948	Electrolytic 1 μ F/50V	CE04W1H010M
				C218,219	254 4260 977	Electrolytic 4.7 μ F/50V	CE04W1H4R7M
				C220	254 4260 980	Electrolytic 10 mF/50V	CE04W1H100M
				C232,233	257 0008 983	Ceramic chip 1000 pF/50V	CK73B1H102K
				C236-238	257 0004 961	Ceramic chip 100 pF/50V	CC73SL1H101J
				C255,256	257 0008 983	Ceramic chip 1000 pF/50V	CK73B1H102K
				C259	257 0008 983	Ceramic chip 1000 pF/50V	CK73B1H102K
				C501,502	254 4260 980	Electrolytic 10 μ F/50V	CE04W1H100M
				C503,504	253 4538 949	Ceramic 100 pF/50V	CC45SL1H101J(DD-3)
				C505,506	253 4537 924	Ceramic 33 pF/50V	CC45SL1H330J(DD-3)
				C507,508	253 4482 901	Ceramic 33 pF/500V	CC45SL2H330J
				C509,510	254 4254 938	Electrolytic 47 μ F/16V	CE04W1C470M
				C511,512	255 4202 941	Polypropylene film 1000 pF/50V	CQ93P1H102J
				C513	254 4260 980	Electrolytic 10 μ F/50V	CE04W1H100M
				C515,516	254 4260 993	Electrolytic 22 μ F/50V	CE04W1H220M
				C531,532	254 4260 980	Electrolytic 10 μ F/50V	CE04W1H100M

**PARTS LIST OF P.W.B. UNIT ASS'Y
1U-3066 POWER AMP UNIT ASS'Y**

Ref. No.	Part No.	Part Name	Remarks
C533,534	253 4538 949	Ceramic 100 pF/50V	CC45SL1H101J(DD-3)
C535,536	253 4537 924	Ceramic 33 pF/50V	CC45SL1H330J(DD-3)
C537,538	253 4482 901	Ceramic 33 pF/500V	CC45SL2H330J
C539,540	255 4202 941	Polypropylene film 1000 pF/50V	CQ93P1H102J
C541,542	254 4260 993	Electrolytic 22 μF/50V	CE04W1H220M
C555,556	254 4254 938	Electrolytic 47 μF/16V	CE04W1C470M
C560	254 4260 980	Electrolytic 10 μF/50V	CE04W1H100M
C561	253 4538 949	Ceramic 100 pF/50V	CC45SL1H101J(DD-3)
C562	253 4537 924	Ceramic 33 pF/50V	CC45SL1H330J(DD-3)
C563	253 4482 901	Ceramic 33 pF/500V	CC45SL2H330J
C564	254 4254 938	Electrolytic 47 μF/16V	CE04W1C470M
C565	255 4202 941	Polypropylene film 1000 pF/50V	CQ93P1H102J
C566	254 4260 993	Electrolytic 22 μF/50V	CE04W1H220M
C637	254 4260 980	Electrolytic 10 μF/50V	CE04W1H100M
C638,639	253 1181 904	Ceramic 0.01 μF/50V	CK45F1H103Z(DD-3)

Ref. No.	Part No.	Part Name	Remarks
SEMICONDUCTORS GROUP			
IC501	268 0073 905	IC ICP-N15	IC protector
IC502	263 0793 002	IC NJM7806FA(S)	
IC503	263 0801 004	IC NJM7812FA(S)	
IC504	263 0641 002	IC NJM7912FA	
IC505	263 0793 002	IC NJM7806FA(S)	
TR507,508	273 0303 910	Transistor 2SC1740S(S)	
TR511,512	274 0151 929	Transistor 2SD2004(Q)	
TR513,514	272 0107 922	Transistor 2SB1328(Q)	
TR519,520	273 0235 923	Transistor 2SC1841(E/F)	
TR527,528	273 0303 910	Transistor 2SC1740S(S)	
TR531,532	274 0151 929	Transistor 2SD2004(Q)	
TR533,534	272 0107 922	Transistor 2SB1328(Q)	
TR539,540	273 0235 923	Transistor 2SC1841(E/F)	
TR544	273 0303 910	Transistor 2SC1740S(S)	
TR546	274 0151 929	Transistor 2SD2004(Q)	
TR547	272 0107 922	Transistor 2SB1328(Q)	
TR550	273 0235 923	Transistor 2SC1841(E/F)	
TR551	271 0131 924	Transistor 2SA988(E/F)	
TR552	273 0429 904	Transistor 2SC3311A	
TR554	273 0429 904	Transistor 2SC3311A	
TR555	271 0192 905	Transistor 2SA933S(S)	
TR556,557	273 0429 904	Transistor 2SC3311A	
TR558	271 0192 905	Transistor 2SA933S(S)	
TR559-565	273 0429 904	Transistor 2SC3311A	
TR566	271 0254 018	Transistor 2SA1725(O/P/Y)	
TR567,568	273 0253 918	Transistor 2SC2878(A/B)	
D501~505	276 0432 903	Diode 1SS270A	
D507~512	276 0553 905	Diode 1SR35-200A	
D513~517	276 0432 903	Diode 1SS270A	
D518~520	276 0305 001	Diode S4VB20	
D521~523	276 0432 903	Diode 1SS270A	
ZD501	276 0644 911	Zener diode MTZJ7.5A	7.5V

OTHER PARTS GROUP			Q'ty
CW051~055	205 0885 008	5P connector socket TUC-P	5
CW111,112	205 0885 066	11P connector socket TUC-P	2
CW143	205 0885 011	14P connector socket TUC-P	1
CW153,154	205 0885 040	15P connector socket TUC-P	2
CW161	205 1056 027	16P connector socket TKC-V	1
CX071,072	205 0943 021	7P connector base (TUC-P)	2
CX081	205 0343 087	8P connector base(KR-PH)	1
CX083	205 0884 096	8P connector base (TUC-P)	1
CX101	205 0884 054	10P connector base (TUC-P)	1
CX113,114	205 0884 067	11P connector base (TUC-P)	2
CX121,122	205 0884 070	12P connector base (TUC-P)	2
CX141~143	205 0884 012	14P connector base (TUC-P)	3
CX151,152	205 0884 041	15P connector base (TUC-P)	2
FB101~103	235 0049 900	Beads inductor	4
FB120,121	235 0049 900	Beads inductor	4
FB122,123	235 0106 908	Chip emifil (21A05)	2
FB126	235 0106 908	Chip emifil (21A05)	3
FB127	235 0049 900	Beads inductor	2
FB129	235 0106 908	Chip emifil (21A05)	3
FB202	235 0106 908	Chip emifil (21A05)	3
X103	399 0191 903	Ceramic 4.00 MHz	1
	205 1034 010	M3 Screw terminal	3

RESISTORS GROUP			
R526~528	244 2052 957	Metal oxide 5.6 kohm 1W	S14B3A562JNB S(S)
R537,538	241 2378 962	Carbon film 330 ohm 1/4W(NB)	RD14B2E331JN BS
R539~542	241 2387 908	Carbon film 1 ohm 1/4W(NB)	RD14B2E010JN BS
R543~550	244 2043 982	Metal oxide 0.22 ohm 1W	S14B3AR22JNB S(S)
R557~571	244 2043 937	Metal oxide 10 ohm 1W	S14B3A100JNB S(S)
R605~608	244 2052 957	Metal oxide 5.6 kohm 1W	S14B3A562JNB S(S)
R619,620	241 2378 962	Carbon film 330 ohm 1/4W(NB)	RD14B2E331JN BS
R621-624	241 2387 908	Carbon film 1 ohm 1/4W(NB)	RD14B2E010JN BS
R625~632	244 2043 982	Metal oxide 0.22 ohm 1W	S14B3AR22JNB S(S)
R639,640	244 2043 937	Metal oxide 10 ohm 1W	S14B3A100JNB S(S)
R672,673	244 2052 957	Metal oxide 5.6 kohm 1W	S14B3A562JNB S(S)
R679	241 2378 962	Carbon film 330 ohm 1/4W(NB)	RD14B2E331JN BS
R680,681	241 2387 908	Carbon film 1 ohm 1/4W(NB)	RD14B2E010JN BS

Ref. No.	Part No.	Part Name	Remarks
R682-685	244 2043 982	Metal oxide 0.22 ohm 1W	S14B3AR22JNBS(S)
R690	244 2043 937	Metal oxide 10 ohm 1W	S14B3A100JNBS(S)
R714,715	243 2039 032	Winding 0.1 ohm 5W	RW99=3H0R1K
R734	242 2009 001	Composition 2.2 Mohm 1/2W	RC05GF2H225K(UL)
R744	241 2376 919	Carbon film 30 ohm 1/4W(NB)	RD14B2E300JNBS
R751,752	244 2052 960	Metal oxide 220 ohm 1W	S14B3A221JNBS(S)
R757,758	244 2052 960	Metal oxide 220 ohm 1W	S14B3A221JNBS(S)
R761	241 2375 978	Carbon film 20 ohm 1/4W(NB)	RD14B2E200JNBS
VR501-505	211 6093 912	Semi fixed resistor 4.7 kohm	V06PB472

CAPACITORS GROUP

C513,514	254 4261 918	Electrolytic 47 μF/50V	CE04W1H470M
C515,516	254 4263 987	Electrolytic 10 μF/100V	CE04W2A100M
C517-520	253 4494 902	Ceramic 100 pF/500V	CC45SL2H101J
C521,522	256 1034 979	Metalized 0.1 μF/50V	CF93A1H104J
C541,542	254 4261 918	Electrolytic 47 μF/50V	CE04W1H470M
C543,544	253 4494 902	Ceramic 100 pF/500V	CC45SL2H101J
C545,546	254 4263 987	Electrolytic 10 μF/100V	CE04W2A100M
C547,548	253 4494 902	Ceramic 100 pF/500V	CC45SL2H101J
C549,550	256 1034 979	Metalized 0.1 μF/50V	CF93A1H104J
C566	254 4261 918	Electrolytic 47 μF/50V	CE04W1H470M
C567	254 4263 987	Electrolytic 10 μF/100V	CE04W2A100M
C568,569	253 4494 902	Ceramic 100 pF/500V	CC45SL2H101J
C570	256 1034 979	Metalized 0.1 μF/50V	CF93A1H104J
C573	253 1181 904	Ceramic 0.01 μF/50V	CK45F1H103Z(DD-3)
C581	254 4254 938	Electrolytic 47 μF/16V	CE04W1C470M
C582	253 9039 906	BC ceramic cap. 0.1 μF/25V	CK45=1E104Z(DD-3)
C583	254 4254 909	Electrolytic 10 μF/16V	CE04W1C100M
C584	253 9039 906	BC ceramic cap. 0.1 μF/25V	CK45=1E104Z(DD-3)
C585	254 4250 945	Electrolytic 330 μF/6.3V	CE04W0J331M
C586	253 9039 906	BC ceramic cap. 0.1 μF/25V	CK45=1E104Z(DD-3)
C587	254 4250 945	Electrolytic 330 μF/6.3V	CE04W0J331M
C588	253 1181 904	Ceramic 0.01 μF/50V	CK45F1H103Z(DD-3)
C589	254 4254 909	Electrolytic 10 μF/16V	CE04W1C100M
C590	254 4260 948	Electrolytic 1 μF/50V	CE04W1H010M
C591-593	253 1181 904	Ceramic 0.01 μF/50V	CK45F1H103Z(DD-3)
C594	254 4256 790	Electrolytic 2200 μF/25V	CE04W1E222MC
C595	254 4260 948	Electrolytic 1 μF/50V	CE04W1H010M
C599	256 1034 979	Metalized 0.1 μF/50V	CF93A1H104J
C601	254 4260 948	Electrolytic 1 μF/50V	CE04W1H010M
C602	254 6200 003	Electrolytic 10000 μF/56V	E68W==103MC(DL)
C603,604	256 1042 903	Metalized 0.1 μF/250V	CF93A2E104K
C605	254 6200 003	Electrolytic 10000 μF/56V	E68W==103MC(DL)
C606-608	256 1042 903	Metalized 0.1 μF/250V	CF93A2E104K
C609-612	255 1265 936	Mylar film 0.01 μF/50V	CQ93M1H103JB)
C615	253 1181 904	Ceramic 0.01 μF/50V	CK45F1H103Z(DD-3)
C617	254 4254 912	Electrolytic 22 μF/16V	CE04W1C220M
C618	253 1179 903	Ceramic 100 pF/50V	CK45B1H101K(DD-3)
C619	254 4260 948	Electrolytic 1 μF/50V	CE04W1H010M

Ref. No.	Part No.	Part Name	Remarks
C620	253 1181 904	Ceramic 0.01 μF/50V	CK45F1H103Z(DD-3)
C621-624	254 4254 938	Electrolytic 47 μF/16V	CE04W1C470M
C629-632	255 1265 936	Mylar film 0.01 μF/50V	CQ93M1H103J(B)
C633,634	253 1180 921	Ceramic 1000 pF/50V	CK45B1H102K(DD-3)
C635	254 4258 947	Electrolytic 47 μF/35V	CE04W1V470M
C636-638	253 1181 904	Ceramic 0.01 μF/50V	CK45F1H103Z(DD-3)
C639,640	254 4258 947	Electrolytic 47 μF/35V	CE04W1V470M
C641	253 1181 904	Ceramic 0.01 μF/50V	CK45F1H103Z(DD-3)
C642	254 4257 702	Electrolytic 3300 μF/25V	CE04W1E332MC
C643	254 4256 787	Electrolytic 1000 μF/25V	CE04W1E102MC
C644,645	256 1034 979	Metalized 0.1 μF/50V	CF93A1H104J
C646	254 4262 784	Electrolytic 470μF/63 V	CE04W1J471MC
C647,648	253 8014 702	Ceramic 0.01 F/400V(AC)	CK45F2GAC103MC
C649	255 1265 936	Mylar film 0.01 μF/50V	CQ93M1H103J(B)
C660	254 4260 948	Electrolytic 1 μF/50V	CE04W1H010M
C662	255 1265 936	Mylar film 0.01 μF/50V	CQ93M1H103J(B)

OTHER PARTS GROUP

Ref. No.	Part No.	Part Name	Remarks	Q'ty
Δ AC501	203 3976 002	AC outlet (2P)		1
CW091	205 0885 037	9P connector socket (TUC-P)		1
CW113	205 0885 066	11P connector socket (TUC-P)		1
CX021	205 0581 001	2P VH connector base		1
CX022,024	205 0606 025	2P wrapping terminal		2
CX031	205 0233 032	3 P EH connector base		1
CX033	205 0343 032	3P connector base (KR-PH)		1
CX051-055	205 0884 009	5P connector base TUC-P		5
CX061-069	205 1064 064	6P pin header (TXX)V		9
CX091	205 0884 038	9P connector base TUC-P		1
CX111,112	205 0884 067	11P connector base TUC-P		2
CX153,154	205 0884 041	15P connector base TUC-P		2
CX963	205 1064 064	6P pin header (TXX)V		1
CY021	205 0581 001	2P VH connector base		1
CY032	205 0087 039	3 P wrapping terminal		1
CY033	205 0343 032	3P connector base (KR-PH)		1
Δ F001	206 1046 001	Fuse 6.3A UL 20mm		1
Δ F008	206 1046 014	Fuse 8A		1
Δ F011,012	206 1039 063	Fuse 2.0A		2
FB502	235 0049 900	Beads inductor		1
JK501	204 8545 004	4P pin jack (GND)		

Ref. No.	Part No.	Part Name	Remarks	Q'ty
JK502	204 8264 013	Head phone jack (NI)		1
L501-505	235 0068 004	Inductor 1μH		5
RL501	214 0127 003	Relay (RY-12W)		1
RL502-504	214 0194 007	Relay (VB12SMBU)		3
RL505	214 0188 000	Relay VS-12MBNR-SM2(TV-8)		1
Δ S501	212 1031 008	Power switch (TV-5)		1
SC501	279 0016 904	Thyristor SF0R1A42		1
Δ T501	233 6073 000	Power trans. (Min)-EU		1
TH501	279 0034 067	Posistor PTH9M04BB222TS2F333		1
TM501,502	205 0472 013	8P SP terminal (EAEK)		2
TP501-505	205 0190 036	3P NH connector base		5
TP510	205 0343 029	2P connector base (KR-PH)		1
	202 0040 909	Fuse clip		8
	415 0309 026	P.V.C. tube (L=20)	for TH501	2

EXPLODED VIEW OF CHASSIS AND CABINET

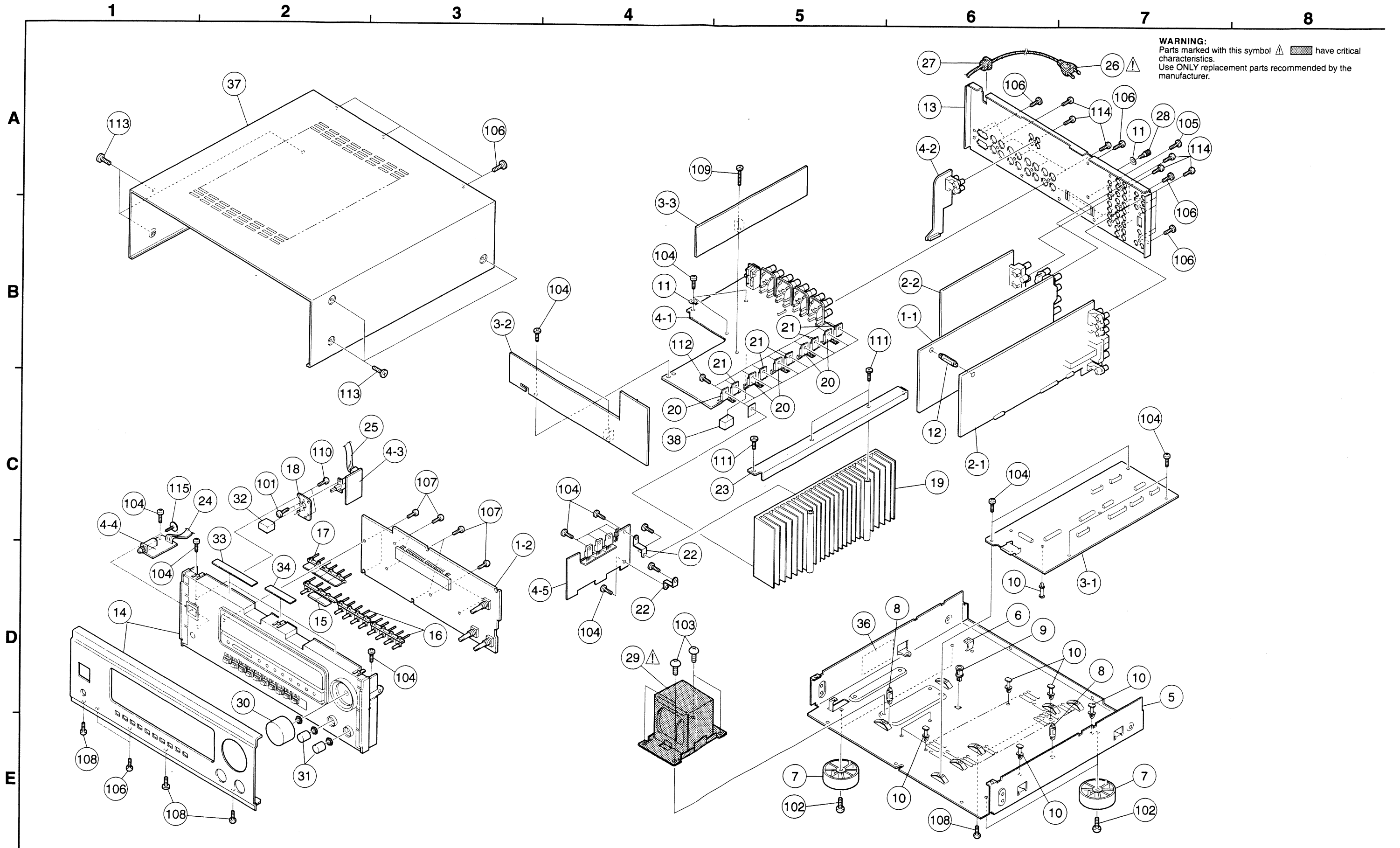

PARTS LIST OF EXPLODED VIEW

Ref. No.	Part No.	Part Name	Remarks	Q'ty	Ref. No.	Part No.	Part Name	Remarks	Q'ty
1	1U-3063	Audio in Disp. P.W.B. unit ass'y		1	SCREWS				
1-1	1U-3063-1	Input surround unit			101	471 3303 016	Screw 3X6 CBS-Z		2
1-2	1U-3063-2	Display unit			102	473 7002 018	Screw 3X8 CBTS(S)-Z		4
2	1U-3064	TU VR video P.W.B. unit ass'y		1	103	473 7004 016	Screw 4X6 CBTS (S)-Z		4
2-1	1U-3064-1	Tuner Ext. in unit			104	473 7005 002	Screw 3X10 CBTS(S)-Z		18
2-2	1U-3064-2	C-video unit			105	473 7006 043	Screw 3X14 CBTS (S)-B		1
3	1U-3065	Control power P.W.B. unit ass'y		1	106	473 7015 018	Screw 3X8 CBTS(S)-B		10
3-1	1U-3065-1	Control unit			107	473 7500 015	Screw 3X8 CBTS(P)-Z		8
3-2	1U-3065-2	Connect unit			108	473 7501 001	Screw 3X10 CBTS (P)-Z		5
3-3	1U-3065-3	AMP UNIT			109	473 7501 030	Screw 3X20 CBTS (P)-Z		1
4	1U-3066	Power amp. P.W.B. unit ass'y		1	110	473 7505 007	Screw 2.6X8 CBTS(P)-Z		2
4-1	1U-3066-1	Power unit			111	473 7508 017	Screw 3X10 CBTS(P)-B		3
4-2	1U-3066-2	Pre out unit			112	473 8007 009	Cup screw 3X12		10
4-3	1U-3066-3	Power switch unit			113	473 8064 000	Screw 4X8 CBTS(B)-B-3P		6
4-4	1U-3066-4	Head phone unit			114	477 0064 107	Fixing screw		18
4-5	1U-3066-5	Regulator unit			115	477 0262 006	Special screw		1
5	411 1372 209	Main chassis		1	PACKING & ACCESORIES (Not included EXPLODED VIEW)				
6	412 4210 002	Bracket		1	151	504 9102 029	Stylen paper		1
7	104 0194 205	Foot ass'y		4	152	505 9102 019	Poly. cover		1
8	449 0133 017	P.W.B. holder		2	153	503 1236 107	Cushion		1
9	412 3548 005	P.W.B. catcher		1	154	505 8006 019	Envelope		1
10	412 2814 028	Card spacer (L=10)		8	155	511 3182 001	Instruction manual		1
11	477 0018 001	Washer (P-87)		2	156	231 0922 009	Loop antenna		1
12	449 0133 004	P.W.B. holder		1	157	395 0023 008	FM ant. ass'y		1
13	105 1260 209	Back panel		1	158	399 0458 002	Remote controller RC-832		1
14	146 2041 101	Inner panel ass'y		1	159	515 0671 504	Service station list (EX)		1
15	113 1804 006	Tuning knob		1	160	529 0079 008	FM ant. adapter		1
16	113 1805 005	Function knob		2	161	501 1988 006	Carton case		1
17	113 1823 100	Tuning-2 knob		1	162	513 1389 006	Control card base		1
18	412 4163 007	Switch bracket		1	163	513 1349 004	Thermal carbon film		1
19	417 0553 001	Power radiator		1	164	515 0690 103	DEL warranty home		1
20	273 0389 031	Transistor 2SC3855 LB(O/P/Y)(Z)		5	165	517 1318 037	UPC label		1
21	271 0240 035	Transistor 2SA1491 LB(O/P/Y)(Z)		5					
22	412 4127 001	P.W.B. bracket (B)		2					
23	412 4296 000	Radiator bracket		1					
24	203 4871 067	3P KR-KR ribbon 175	CN033	1					
25	203 2374 029	2P VA-VA cord	CN021	1					
△	28 206 2060 002	AC cord (polarized)		1					
△	27 445 0056 008	Cord bush		1					
	28 205 0071 016	Terminal ass'y		1					
△	29 233 6232 003	Power trans. (E3)		1					
	30 112 0744 067	VR. knob ass'y		1					
	31 112 0685 100	Knob (MARU)		2					
	32 113 9213 000	P-knob (P) ass'y		1					
	33 461 0976 009	Rubber sheet		2					
	34 461 0976 012	Rubber sheet		1					
	35 445 8004 007	Wire clasper		3					
	36 513 2706 028	Caution label		1					
	37 102 0583 030	Top cover		1					
	38 461 0539 048	Rubber sheet		1					

WIRING DIAGRAM

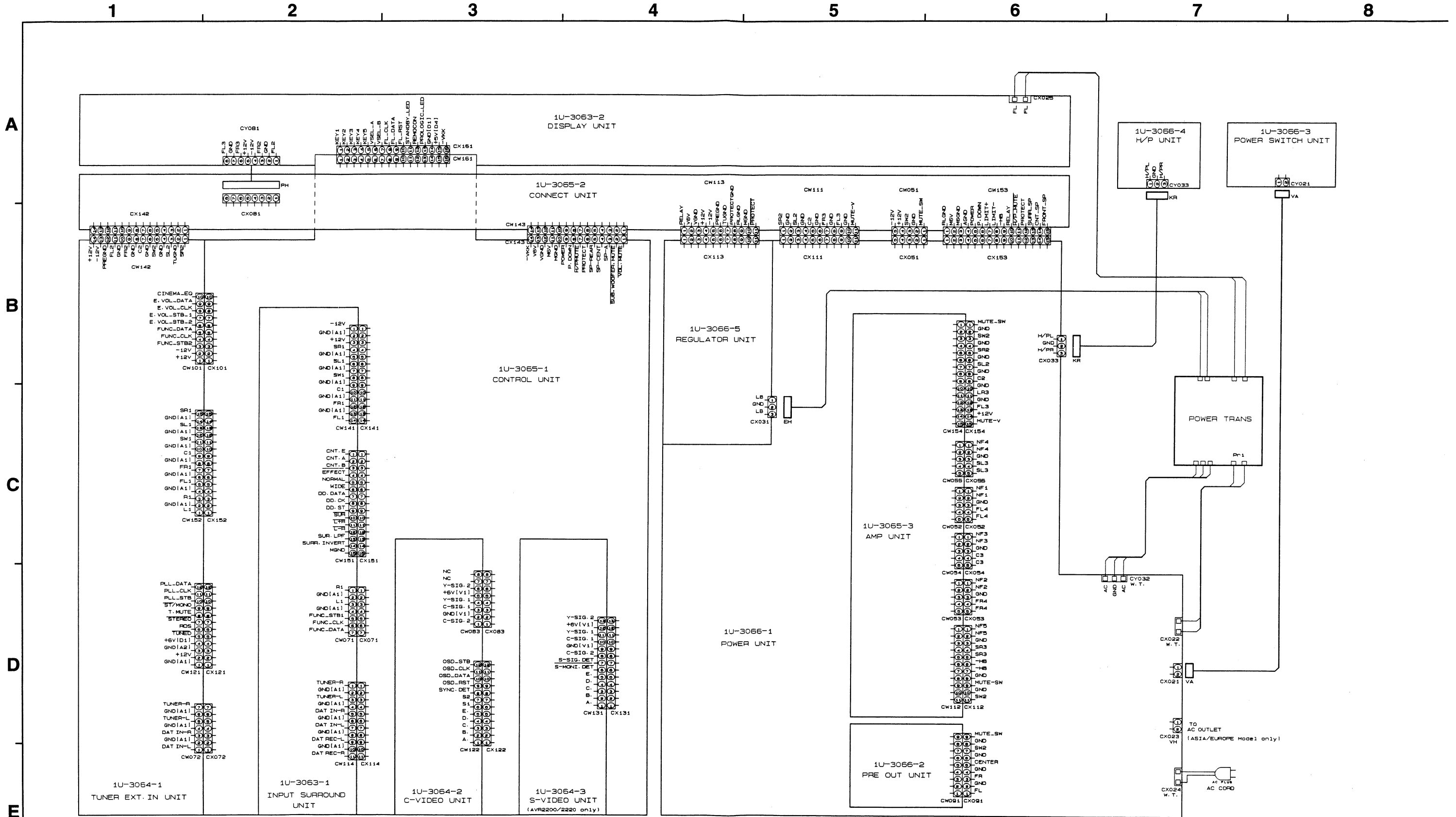

SCHEMATIC DIAGRAM (1/9)

1 2 3 4 5 6

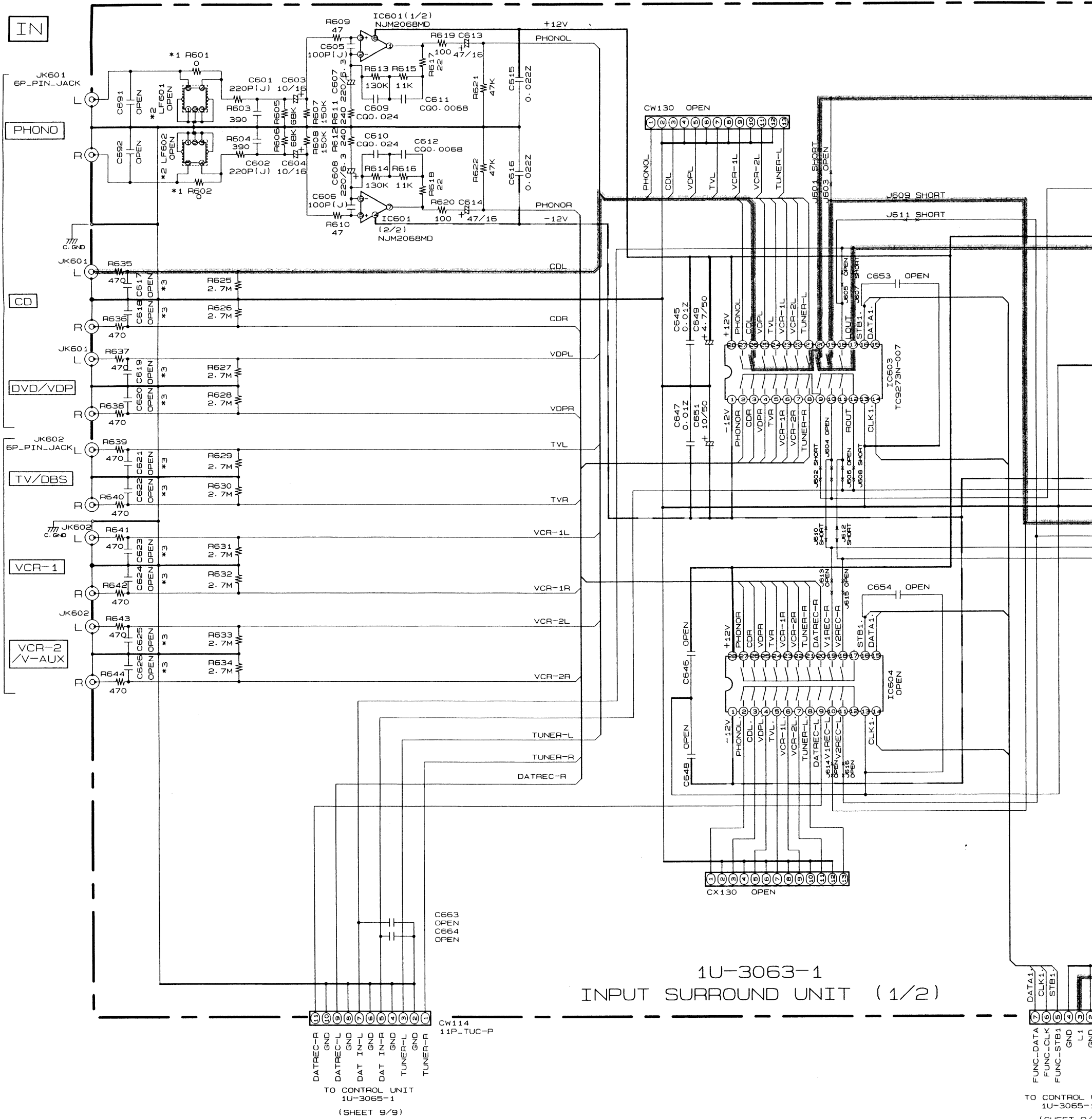

	*1 R601, 602	*2 LF601, 602	*3 C617~626
* USA TAIWAN R. O. C.	0	—	—
ASIA	1.3K	L. P. F.	330P
EUROPE	1.3K	L. P. F.	330P
JAPAN	0	—	—

NOTICE
ALL RESISTANCE VALUES IN OHM. k=1,000 OHM M=1,000,000 OHM
ALL CAPACITANCE VALUES IN MICRO FARAD. P=MICRO-MICRO FARAD
EACH VOLTAGE AND CURRENT ARE MEASURED AT NO SIGNAL INPUT
CONDITION.
CIRCUIT AND PARTS ARE SUBJECT TO CHANGE WITHOUT PRIOR
NOTICE.

6 7 8 9 10 11

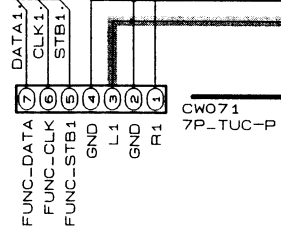
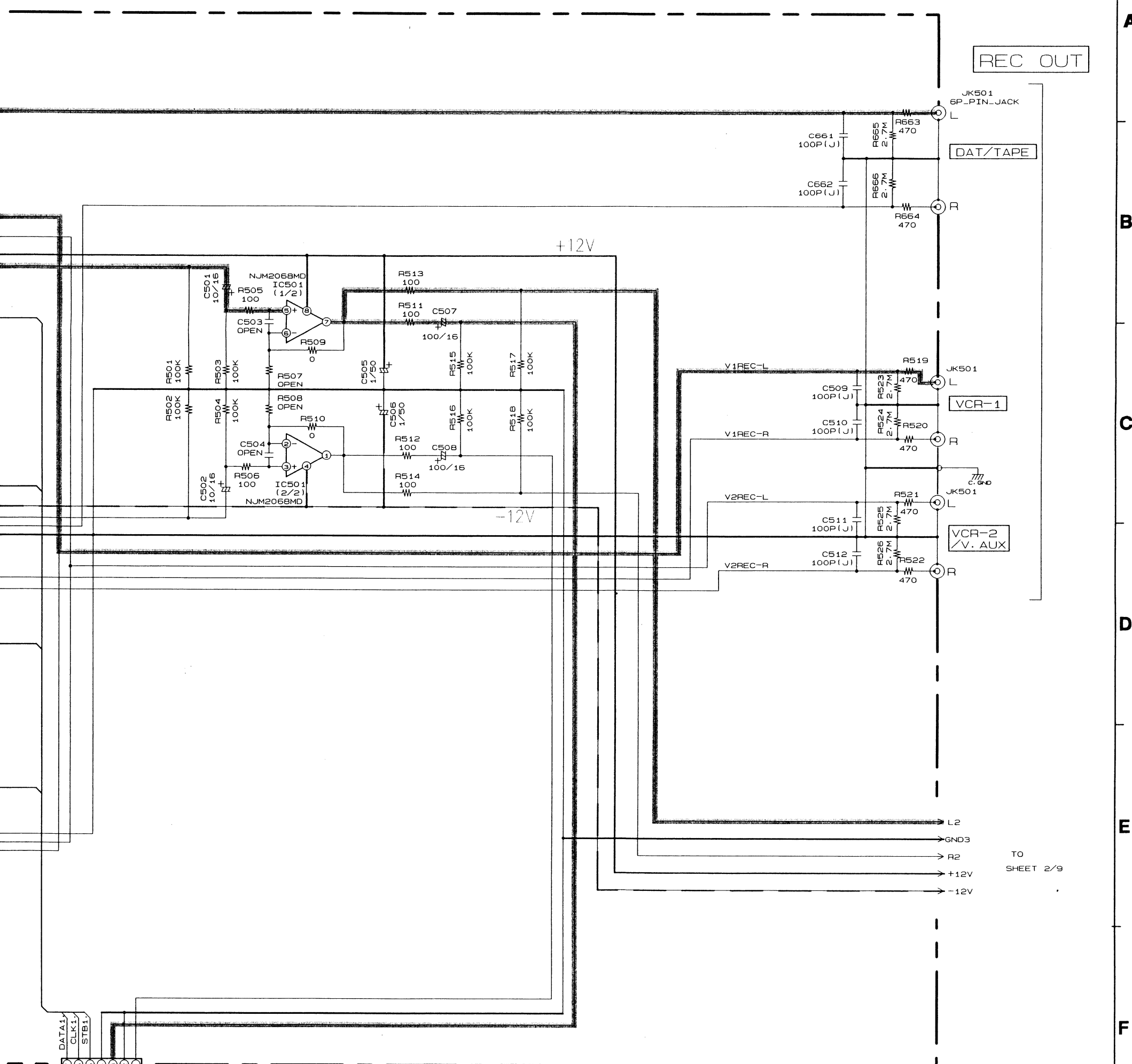

TO CONTROL UNIT
1U-3065-1
(SHEET 9/9)

TO SHEET 2/9

— +B LINE
- - -B LINE
- / - SIGNAL LINE

1,000,000 OHM
RO-MICRO FARAD
O SIGNAL INPUT
OUT PRIOR

WARNING:
Parts marked with this symbol have critical characteristics. Use ONLY replacement parts recommended by the manufacturer.

CAUTION:
Before returning the unit to the customer, make sure you make either (1) a leakage current check or (2) a line to chassis resistance check. If the leakage current exceeds 0.5 milliamperes, or if the resistance from chassis to either side of the power cord is less than 240 kohms, the unit is defective.

WARNING:
DO NOT return the unit to the customer until the problem is located and corrected.

SCHEMATIC DIAGRAM (1/9)

A
B
C
D
E
F
G
H

1 2 3 4 5 6

A

B

C

D

E

F

G

H

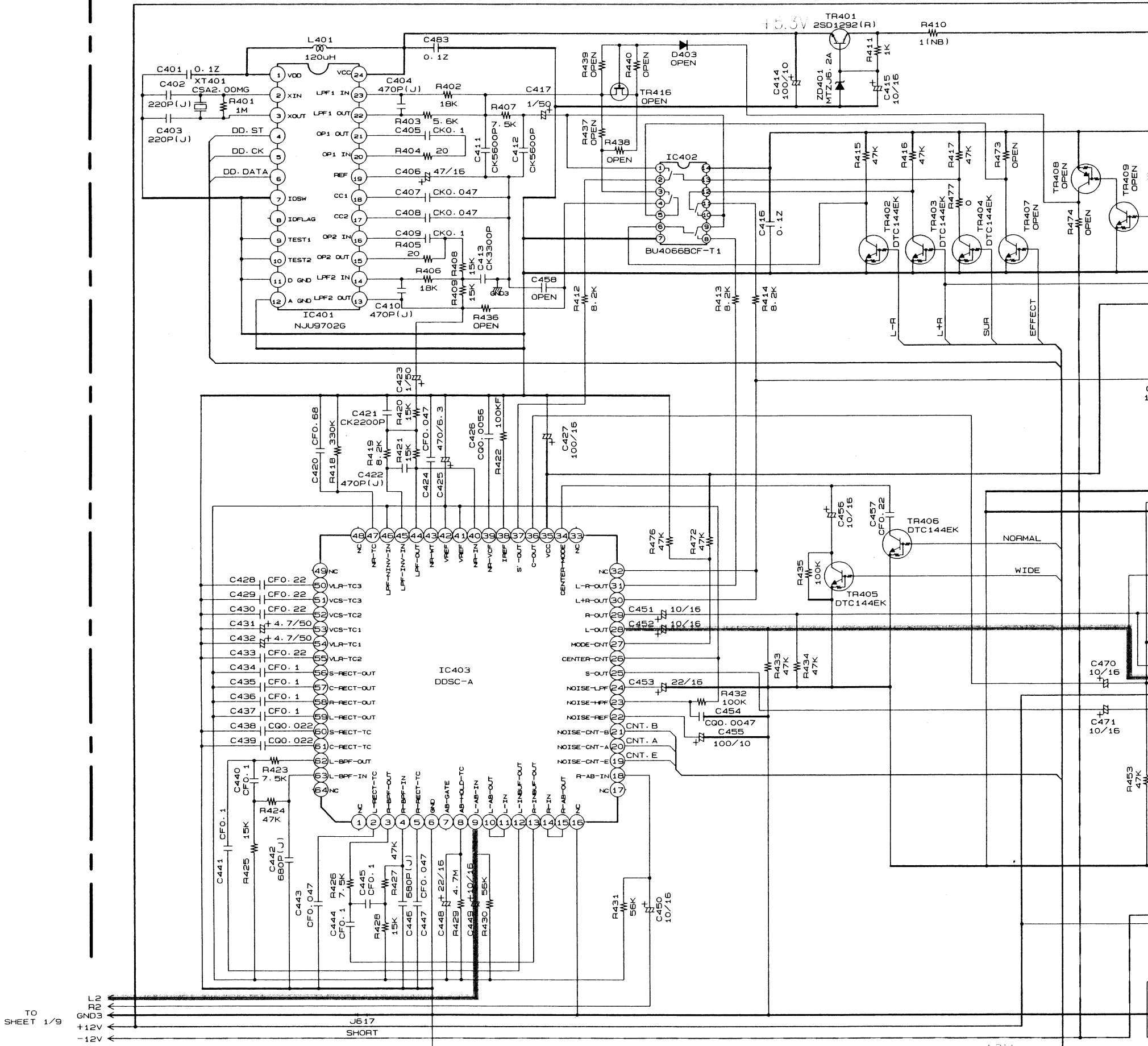

1U-3063-1
INPUT SURROUND UNIT (2/2)

NOTICE
ALL RESISTANCE VALUES IN OHM. k=1,000 OHM M=1,000,000 OHM
ALL CAPACITANCE VALUES IN MICRO FARAD. P=MICRO-MICRO FARAD
EACH VOLTAGE AND CURRENT ARE MEASURED AT NO SIGNAL INPUT
CONDITION.
CIRCUIT AND PARTS ARE SUBJECT TO CHANGE WITHOUT PRIOR NOTICE.

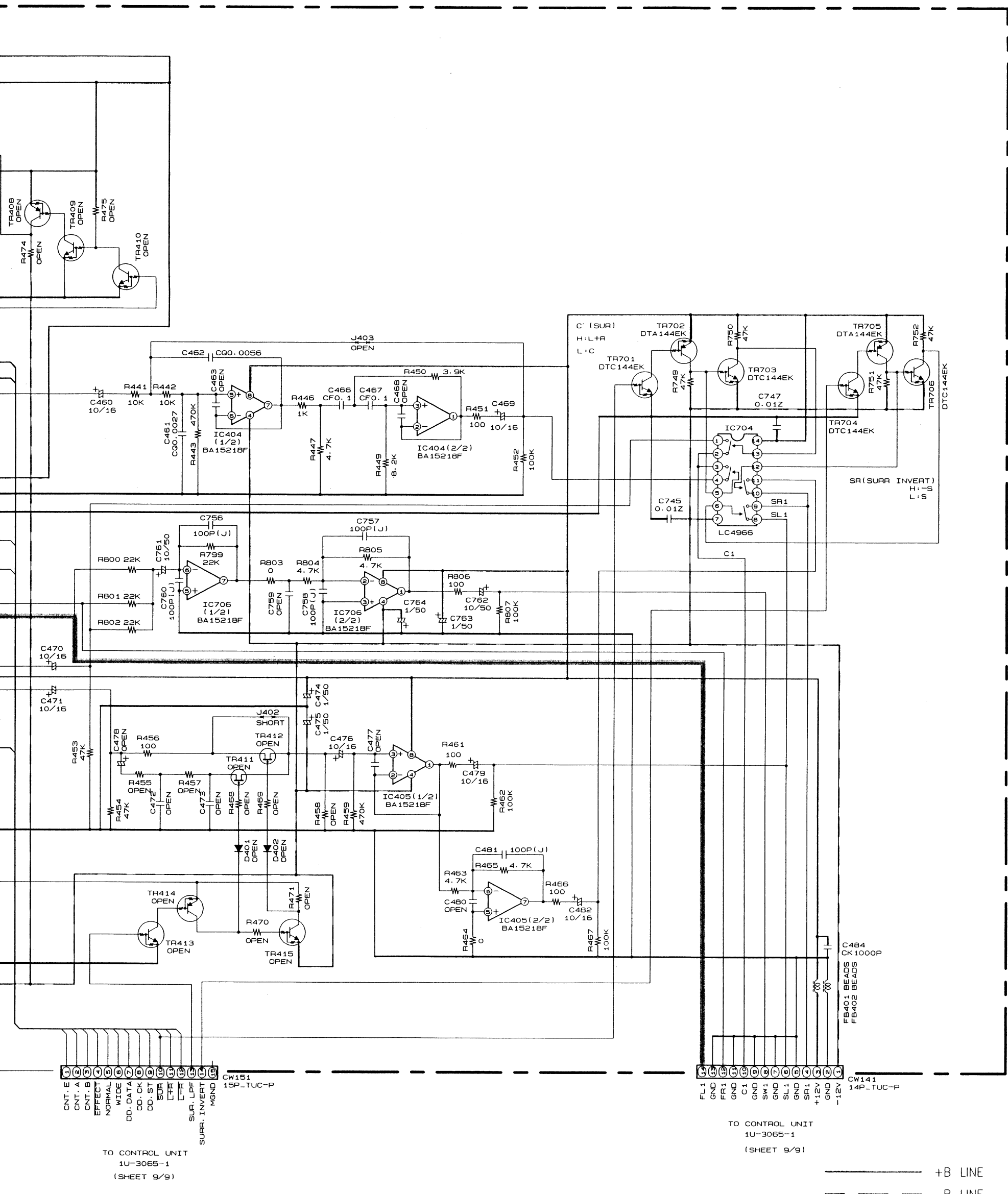

OHM M=1,000,000 OHM
 P=MICRO-MICRO FARAD
 OPEN AT NO SIGNAL INPUT
 CHANGE WITHOUT PRIOR

WARNING:
 Parts marked with this symbol have critical characteristics. Use ONLY replacement parts recommended by the manufacturer.

CAUTION:
 Before returning the unit to the customer, make sure you make either (1) a leakage current check or (2) a line to chassis resistance check. If the leakage current exceeds 0.5 milliamps, or if the resistance from chassis to either side of the power cord is less than 240 kohms, the unit is defective.

WARNING:
 DO NOT return the unit to the customer unit the problem is located and corrected.

TO CONTROL UNIT
 1U-3065-1
 (SHEET 9/9)

TO CONTROL UNIT
 1U-3065-1
 (SHEET 9/9)

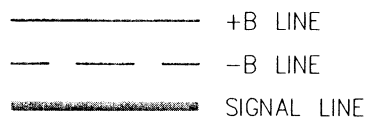

SCHEMATIC DIAGRAM (2/9)

SCHEMATIC DIAGRAM (3/9)

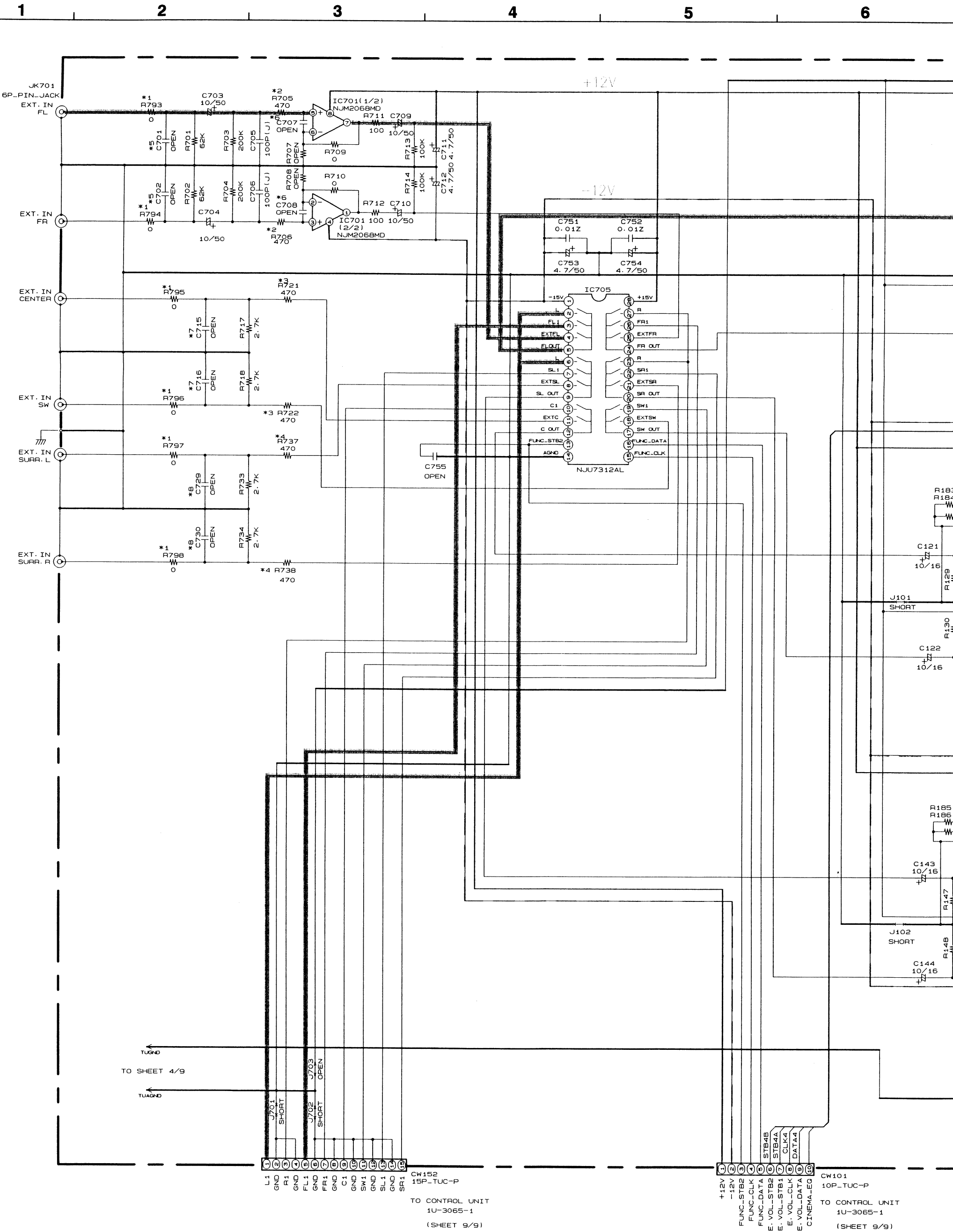

	*1 R793~798	*2 R705, 706	*3 R721, 722	*4 R737, 738	*5 C701, 702	*6 C707, 708	*7 C715, 716	*8 C729, 730	*9 R123, 124	*10 R125, 126	*11 R171, 172	*12 R173	*13 R174 ~177	*14 C119, 120	*15 C171, 172	*16 C173
* USA	0	470	470	470	—	—	—	—	—	0	—	—	—	—	—	—
TAIWAN R. O. C.	0	470	470	470	—	—	—	—	—	0	—	—	—	—	—	—
ASIA (AVR1400)	470	100	100	100	330P	100P	330P	330P	—	0	—	—	—	—	—	—
EUROPE	470	100	100	100	330P	100P	330P	330P	—	0	—	—	—	—	—	—
JAPAN	0	470	470	470	—	—	—	—	1K	1K	330	6.8K	47K	100P [J]	CF0.068	CO0.0082
ASIA (AVR2200)	470	100	100	100	330P	100P	330P	330P	1K	1K	330	6.8K	47K	100P [J]	CF0.068	CO0.0082

TO CONTROL UNIT
1U-3065-1
(SHEET 9/9)

TO CONTROL UNIT
1U-3065-1
(SHEET 9/9)

6 7 8 9 10 11

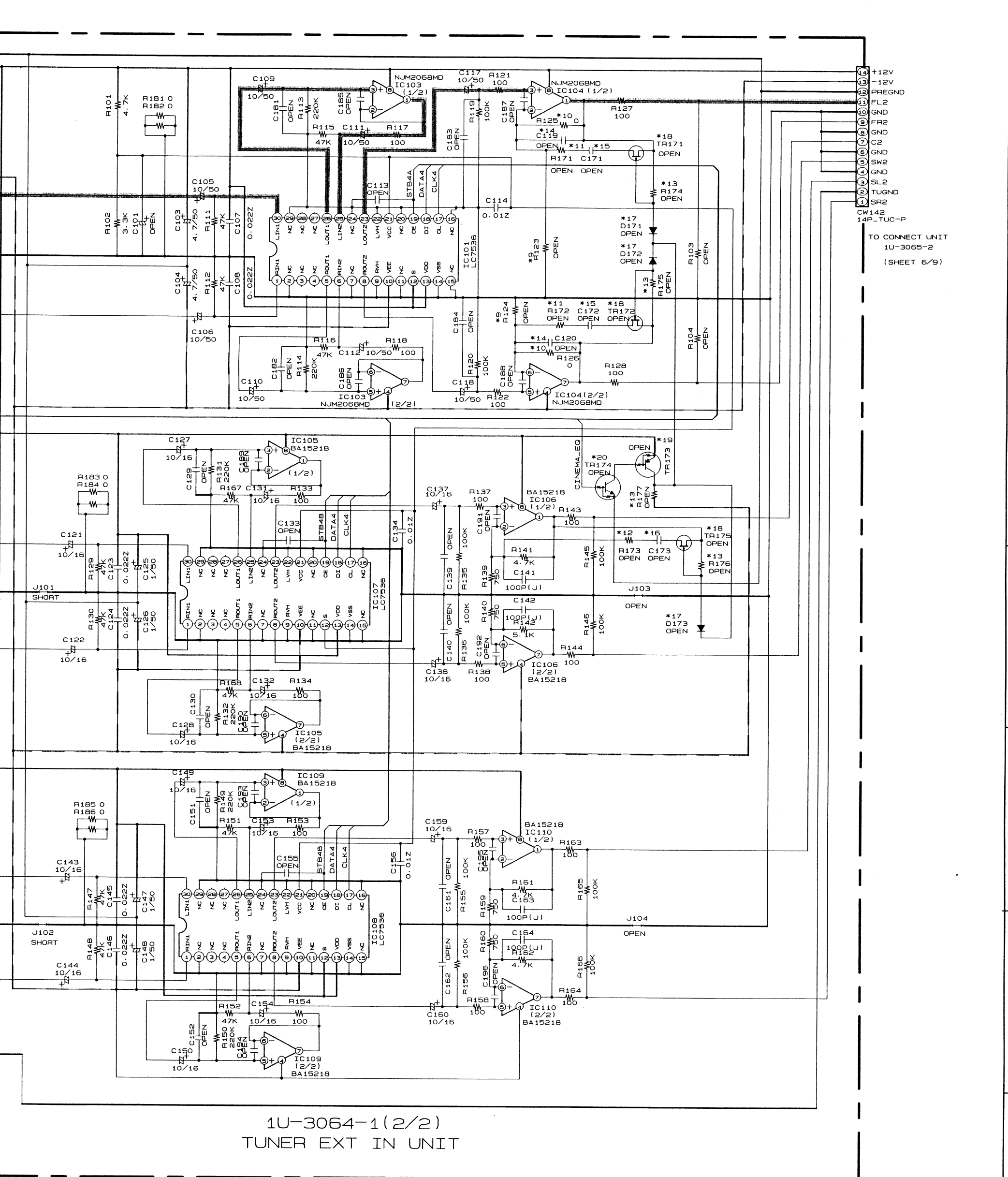

1U-3064-1(2/2)
TUNER EXT IN UNIT

NOTICE
ALL RESISTANCE VALUES IN OHM. k=1,000 OHM M=1,000,000 OHM
ALL CAPACITANCE VALUES IN MICRO FARAD. P=MICRO-MICRO FARAD
EACH VOLTAGE AND CURRENT ARE MEASURED AT NO SIGNAL INPUT CONDITION.
CIRCUIT AND PARTS ARE SUBJECT TO CHANGE WITHOUT PRIOR NOTICE.

WARNING:
Parts marked with this symbol have critical characteristics. Use ONLY replacement parts recommended by the manufacturer.

CAUTION:
Before returning the unit to the customer, make sure you make either (1) a leakage current check or (2) a line to chassis resistance check. If the leakage current exceeds 0.5 milliamps, or if the resistance from chassis to either side of the power cord is less than 240 kohms, the unit is defective.

WARNING:
DO NOT return the unit to the customer unit the problem is located and corrected.

*15 C171-172	*16 C173	*17 D171 ~173	*18 TR171, 172, 175	*19 TR173	*20 TR174
CF0.068	CQ0.0082	1SS270A	2SK209(GR)	DTA144EK	DTC144EK
CF0.068	CQ0.0082	1SS270A	2SK209(GR)	DTA144EK	DTC144EK

— +B LINE
- - - -B LINE
— SIGNAL LINE

SCHEMATIC DIAGRAM (3/9)

A
B
C
D
E
F
G
H

SCHEMATIC DIAGRAM (4/9)

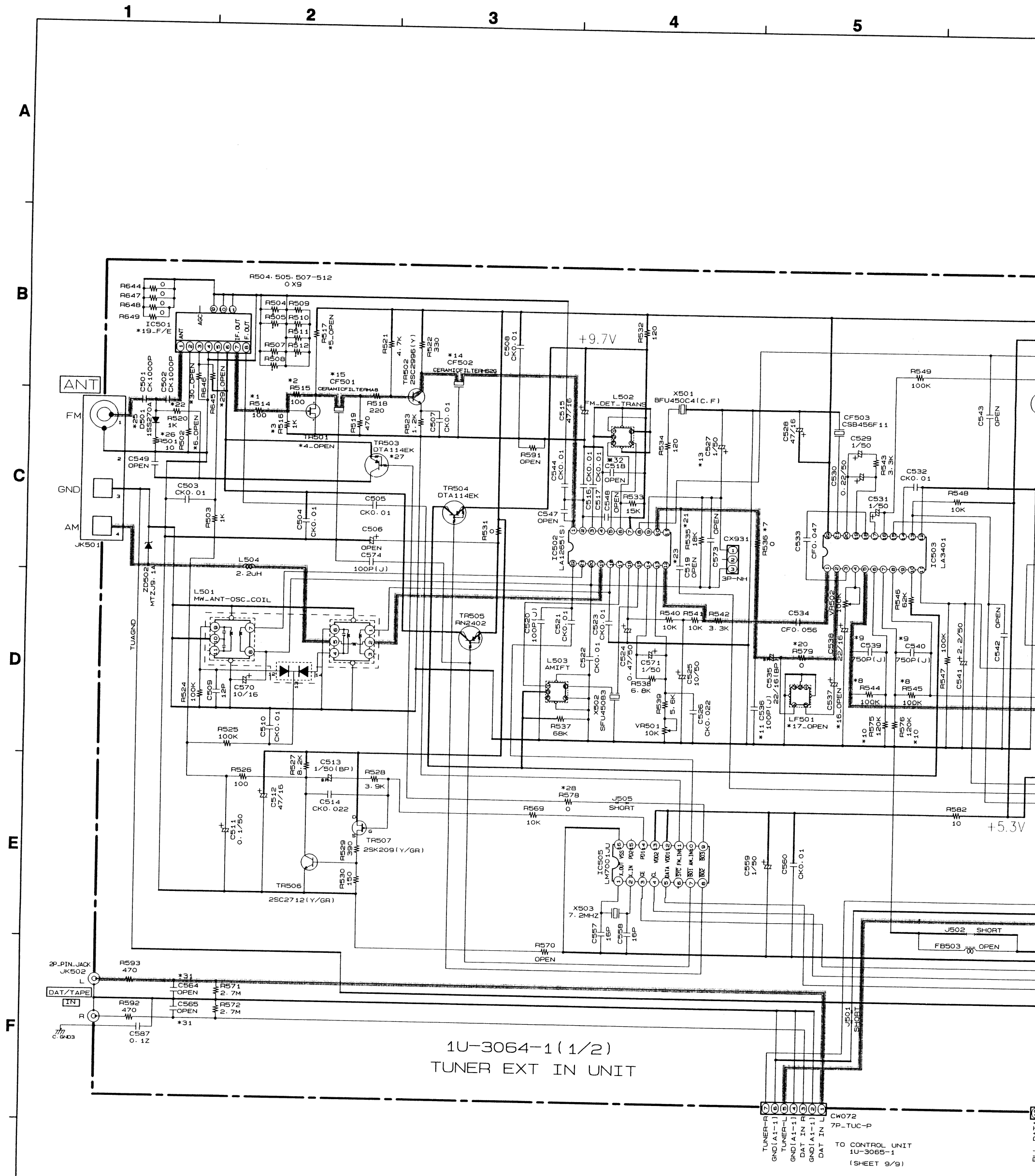

NOTICE
 ALL RESISTANCE VALUES IN OHM. k=1,000 OHM M=1,000,000 OHM
 ALL CAPACITANCE VALUES IN MICRO FARAD. P=MICRO-MICRO FARAD
 EACH VOLTAGE AND CURRENT ARE MEASURED AT NO SIGNAL INPUT
 CONDITION.
 CIRCUIT AND PARTS ARE SUBJECT TO CHANGE WITHOUT PRIOR
 NOTICE.

WARNING:
 Parts marked with this symbol Δ have critical characteristics.
 Use ONLY replacement parts recommended by the manufacturer.

CAUTION:
 Before returning the unit to the customer, make sure you make either
 leakage current check or (2) a line to chassis resistance check. If the
 current exceeds 0.5 milliamps, or if the resistance from chassis to ei
 of the power cord is less than 240 kohms, the unit is defective.

WARNING:
 DO NOT return the unit to the customer unit the problem is located
 corrected.

TUNER-R
 GND(A1-1)
 TUNER-L
 GND(A1-1)
 DAT IN R
 GND(A1-1)
 DAT IN L
 CW072
 7P-TUC-P
 TO CONTROL UNIT
 1U-3065-1
 (SHEET 9/9)

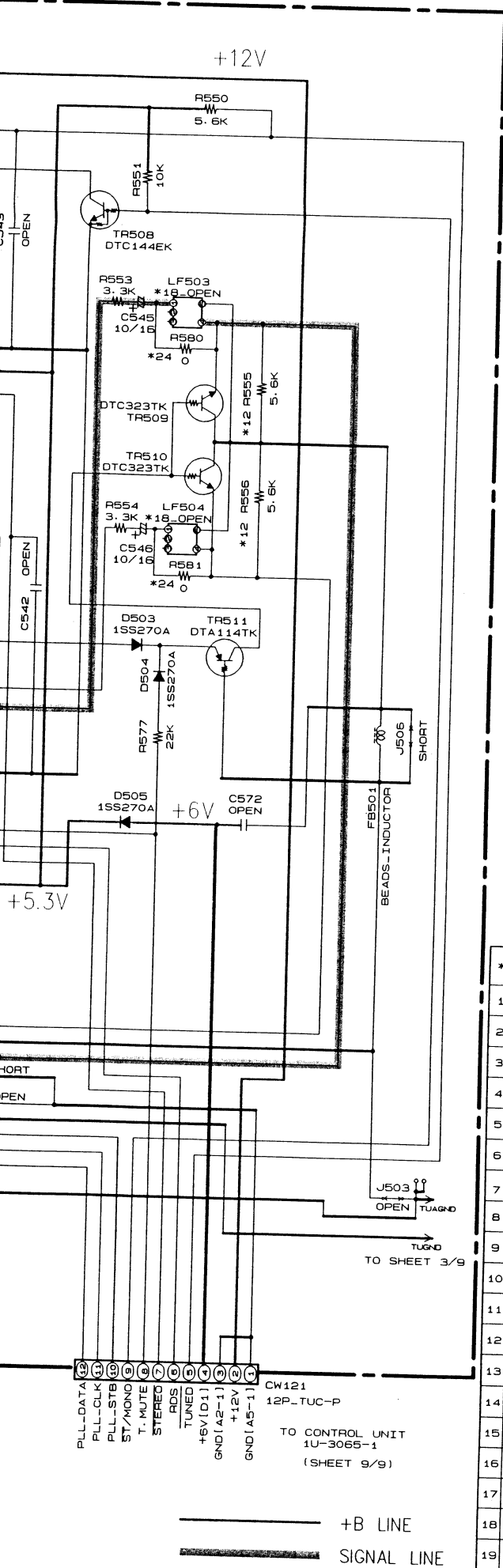

* NO	* USA	TAIWAN	ASIA	EUROPE	JAPAN
1 R514		100		100	0
2 R515		100			100
3 R516		1K		330	330
4 TR501				2SK211[GR]	
5 R517				330	
6 R502				0	
7 R536		0		2.7K	0
8 R544, 545		100K		150K	100K
9 C539, 540	750p		510P	330P	510p
10 R575, 576		120K		200K	120K
11 C536		100p			
12 R555, 556		5.6K		3.3K	5.6K
13 C527	1/50		0.33/50	0.33/50	0.33/50
14 CF502		SFE 10.7MS2G		SFT 10.7MS2	SFE 10.7MS2G
15 CF501		SFE 10.7MAB		SFT 10.7MS2	SFE 10.7MAB
16 C537				22/16	
17 LF501				ANTI BIRDIE FILTER	
18 LF503, 504				LPF 2320085004	LPF 2320085004
19 IC501		F/E 2160102008		F/E 2169013004	F/E 2169012005

* NO	* USA	TAIWAN	ASIA	EUROPE	JAPAN
20 R579		0			0
21 R535	18K		39K	39K	18K
22 R520		1K		1K	
23 C519				CK 100p	
24 R580, 581		0			
25 D501		1SS270A		1SS270A	
26 R501		10		10	
27 TR503		DTA114EK		DTA114EK	
28 R578		0		0	
29 R645				10K	
30 R646				5.6K	
31 C564, 565				330P	
32 C518				270P	

Characteristics.
 Manufacturer.
 You make either (1) a
 check. If the leakage
 chassis to either side
 defective.

is located and

SCHEMATIC DIAGRAM (5/9)

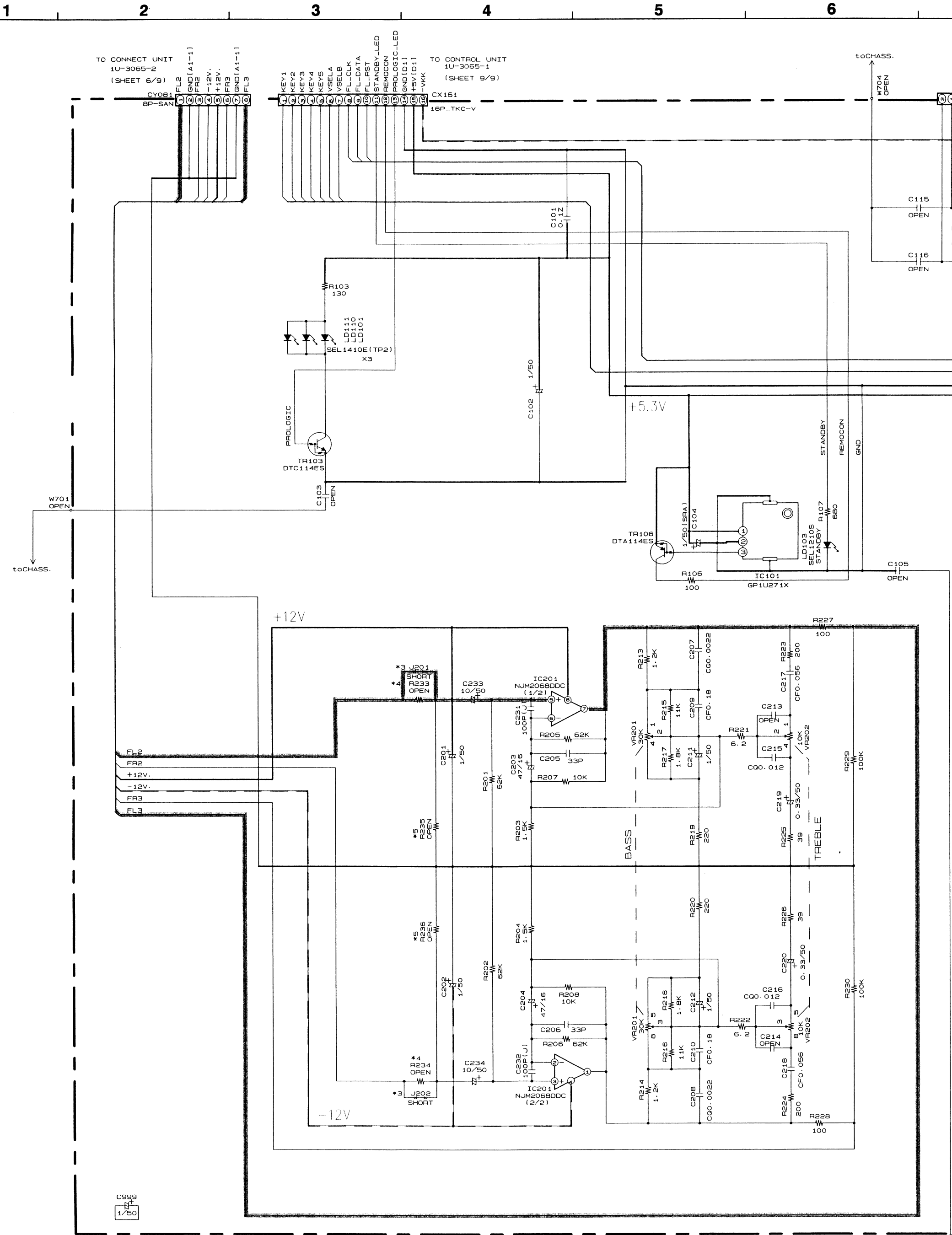

R996	R997	R998
47K	47K	OPEN
1/50	1/50	1/50

	*1	*2	*3	*4	*5
	S115	R160	J201, 202	R233, 234	R235, 236
* USA / EUROPE	—	—	SHORT	—	—
TAIWAN R. O. C. / ASIA (AVR1400)	—	—	—	—	—
JAPAN / ASIA (AVR2200)	TACT SW	510	OPEN	9.1K	15K

	C205, 206
* USA	33P
TAIWAN R. O. C.	33P
ASIA	470P
EUROPE	470P

NOTICE
 ALL RESISTANCE VALUES IN OHM \leq 1,000 OHM \leq 1M
 ALL CAPACITANCE VALUES IN MICRO FARAD. P-MICRO
 EACH VOLTAGE AND CURRENT ARE MEASURED AT NO
 LOAD CONDITION.
 CIRCUIT AND PARTS ARE SUBJECT TO CHANGE WITH
 NOTICE

7 8 9 10 11

A
B
C
D
E
F
G
H

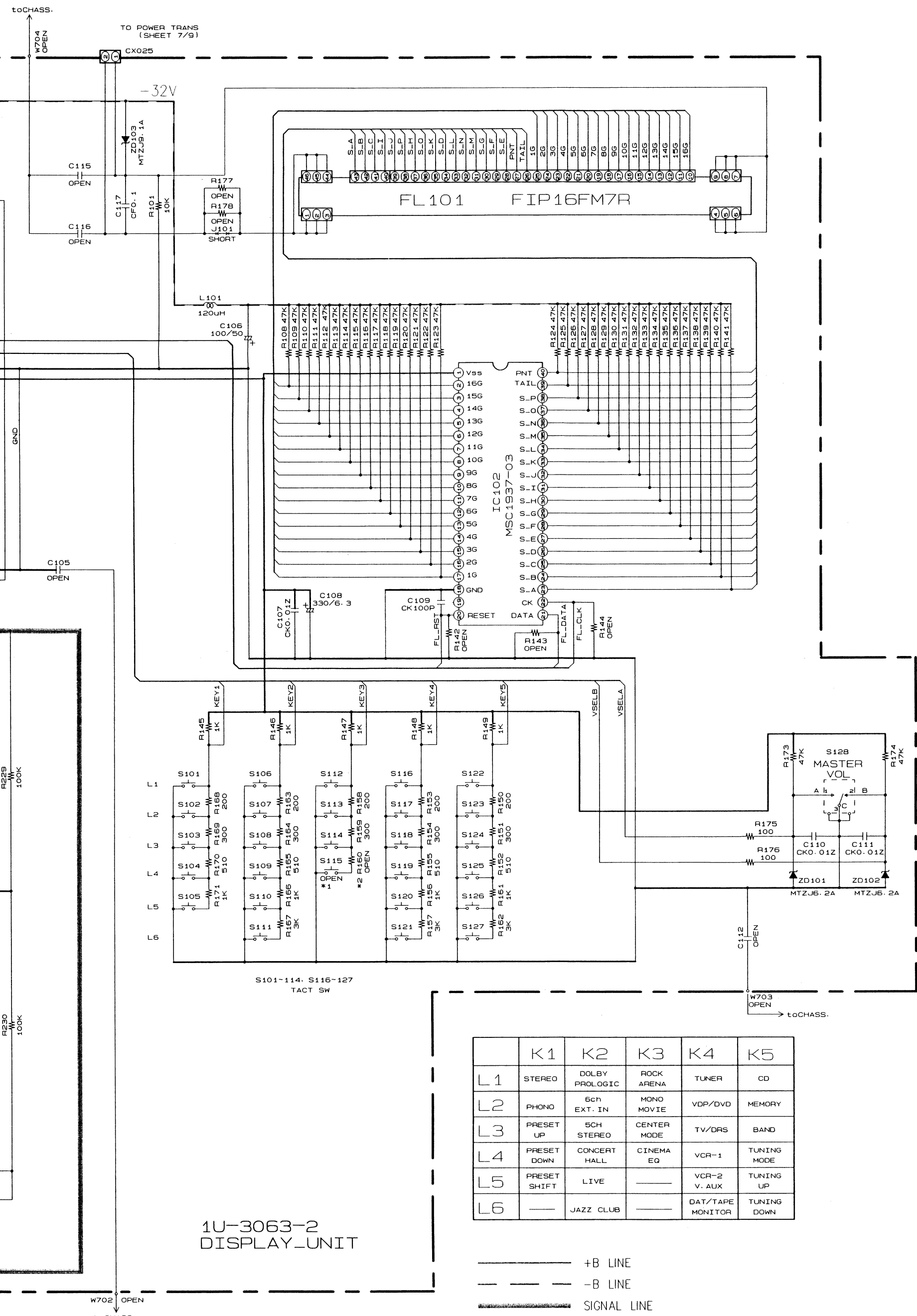

1U-3063-2
DISPLAY UNIT

	K1	K2	K3	K4	K5
L1	STEREO	DOLBY PROLOGIC	ROCK ARENA	TUNER	CD
L2	PHONO	6ch EXT. IN	MONO MOVIE	VDP/DVD	MEMORY
L3	PRESET UP	5CH STEREO	CENTER MODE	TV/DRS	BAND
L4	PRESET DOWN	CONCERT HALL	CINEMA EQ	VCR-1	TUNING MODE
L5	PRESET SHIFT	LIVE	---	VCR-2 V. AUX	TUNING UP
L6	---	JAZZ CLUB	---	DAT/TAPE MONITOR	TUNING DOWN

----- +B LINE
 - - - - - -B LINE
 _____ SIGNAL LINE

WARNING:
 Parts marked with this symbol have critical characteristics. Use ONLY replacement parts recommended by the manufacturer.
CAUTION:
 Before returning the unit to the customer, make sure you make either (1) a leakage current check or (2) a line to chassis resistance check. If the leakage current exceeds 0.5 millamps, or if the resistance from chassis to either side of the power cord is less than 240 kohms, the unit is defective.
WARNING:
 DO NOT return the unit to the customer until the problem is located and corrected.

SCHEMATIC DIAGRAM (5/9)

SCHEMATIC DIAGRAM (6/9)

1 2 3 4 5 6

A
B
C
D
E
F
G
H

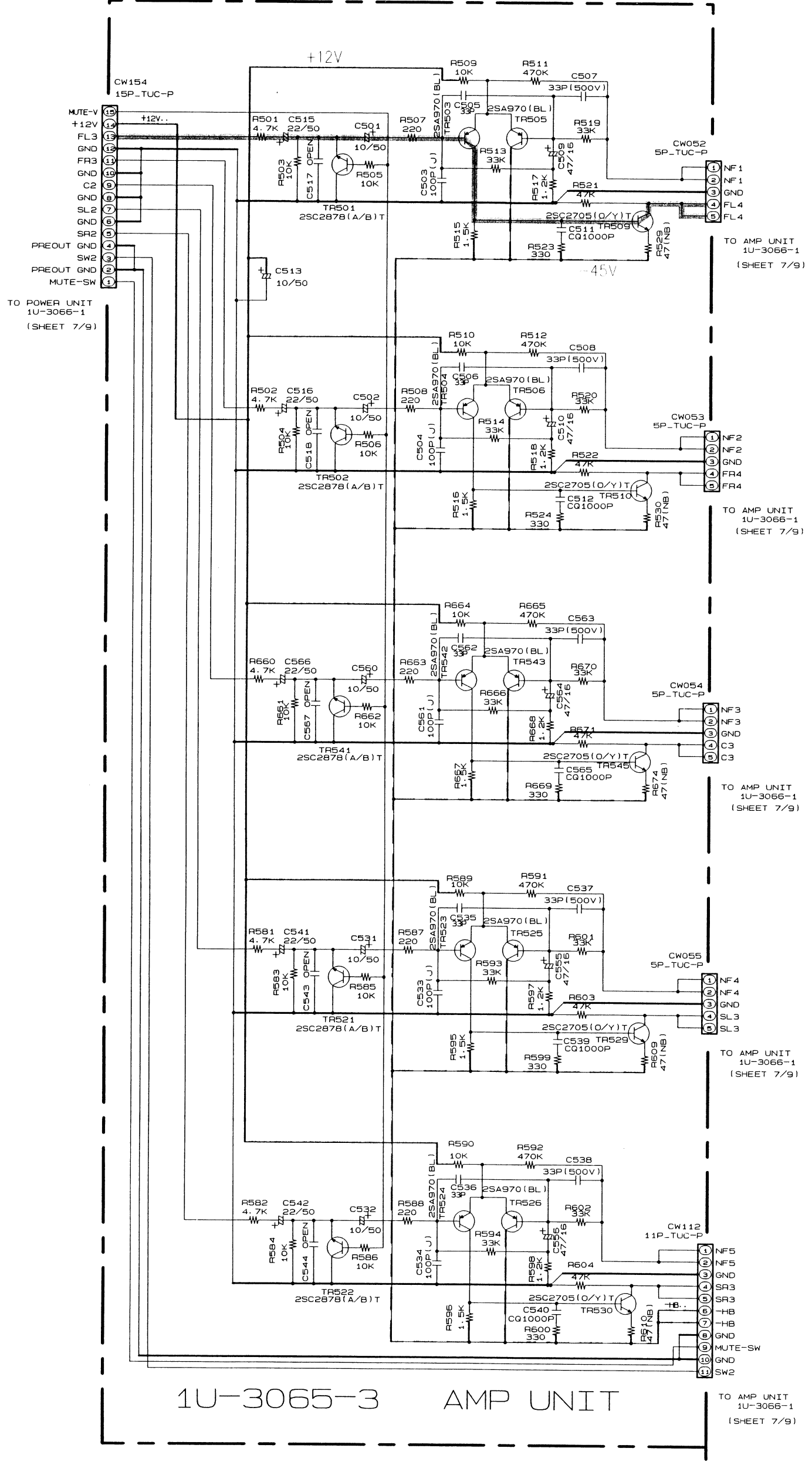

	C205,206	C509,510	
USA TAIWAN R.O.C	—	47/16	
ASIA	—	47/16	
EUROPE	560p	100/16	

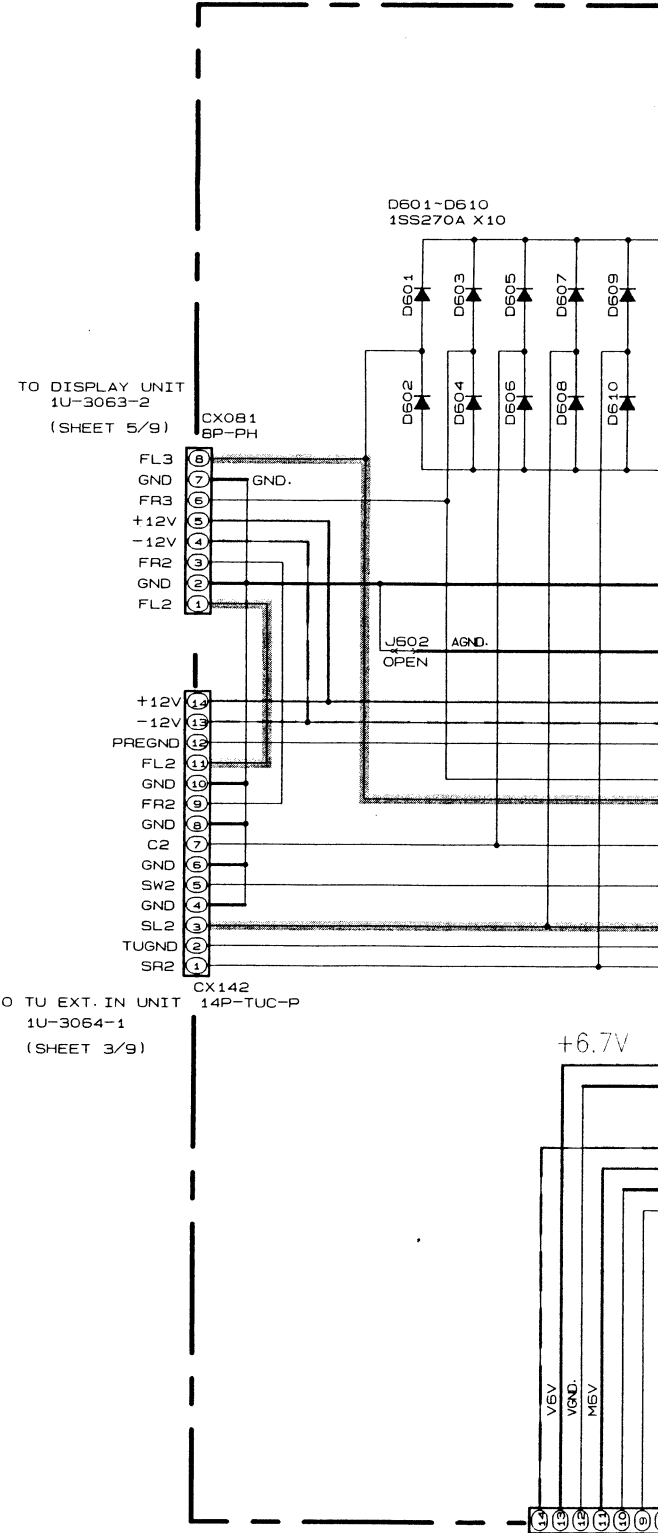

NOTICE
 ALL RESISTANCE VALUES IN OHM.
 ALL CAPACITANCE VALUES IN MICR.
 EACH VOLTAGE AND CURRENT ARE
 CONDITION.
 CIRCUIT AND PARTS ARE SUBJECT
 NOTICE.

C509,510	C515,516	C505,506	C535,536,562
47/16	22/50	33p	33p
47/16	22/50	220p	220p
100/16	47/16	470p	220p

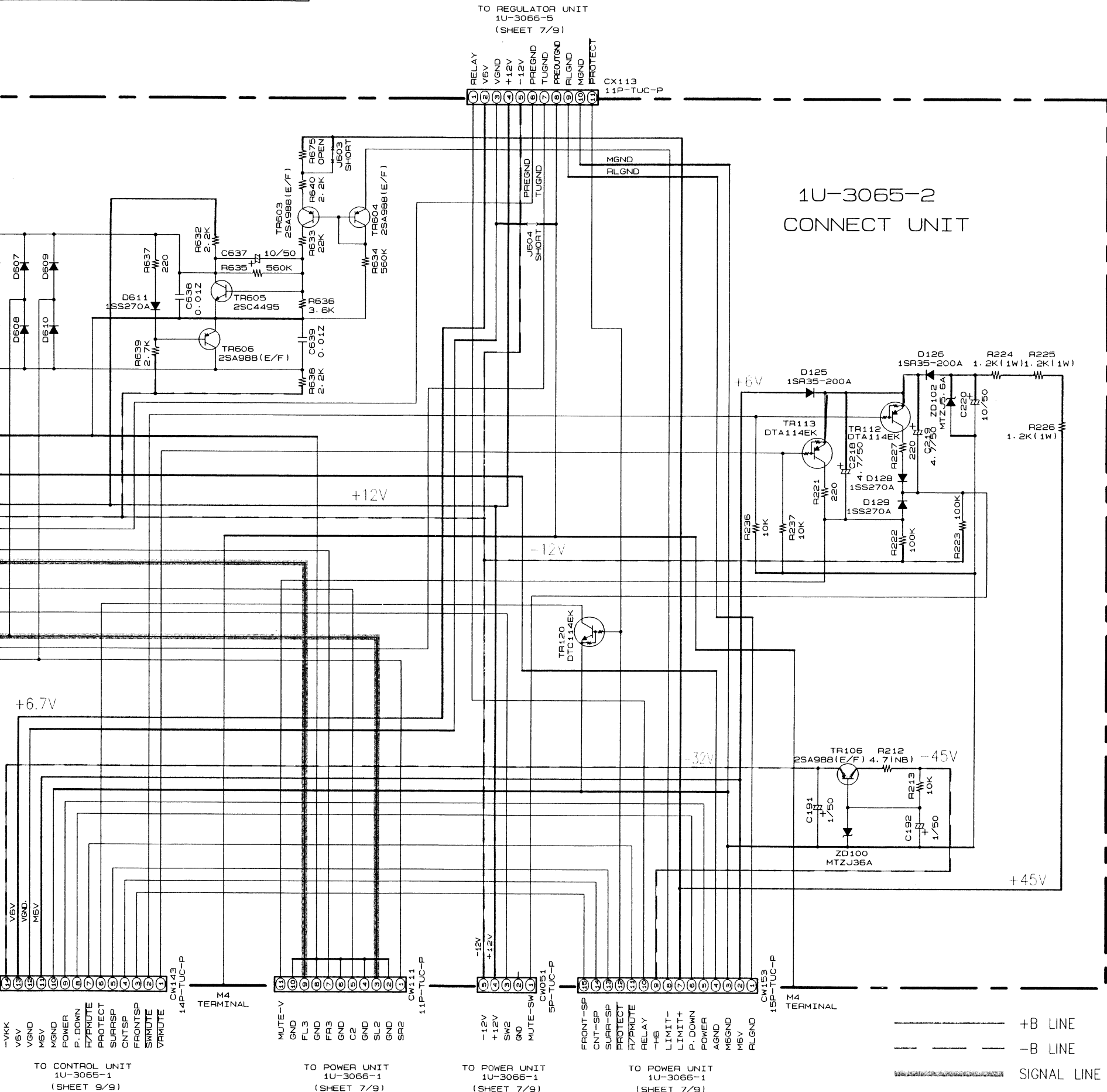

WARNING:

Parts marked with this symbol have critical characteristics. Use ONLY replacement parts recommended by the manufacturer.

CAUTION:

Before returning the unit to the customer, make sure you make either (1) a leakage current check or (2) a line to chassis resistance check. If the leakage current exceeds 0.5 milliamps, or if the resistance from chassis to either side of the power cord is less than 240 kohms, the unit is defective.

WARNING:

DO NOT return the unit to the customer unit the problem is located and corrected.

VALUES IN OHM. k=1,000 OHM M=1,000,000 OHM
VALUES IN MICRO FARAD. P=MICRO-MICRO FARAD
CURRENT ARE MEASURED AT NO SIGNAL INPUT
ARE SUBJECT TO CHANGE WITHOUT PRIOR

SCHEMATIC DIAGRAM (7/9)

1 2 3 4 5 6

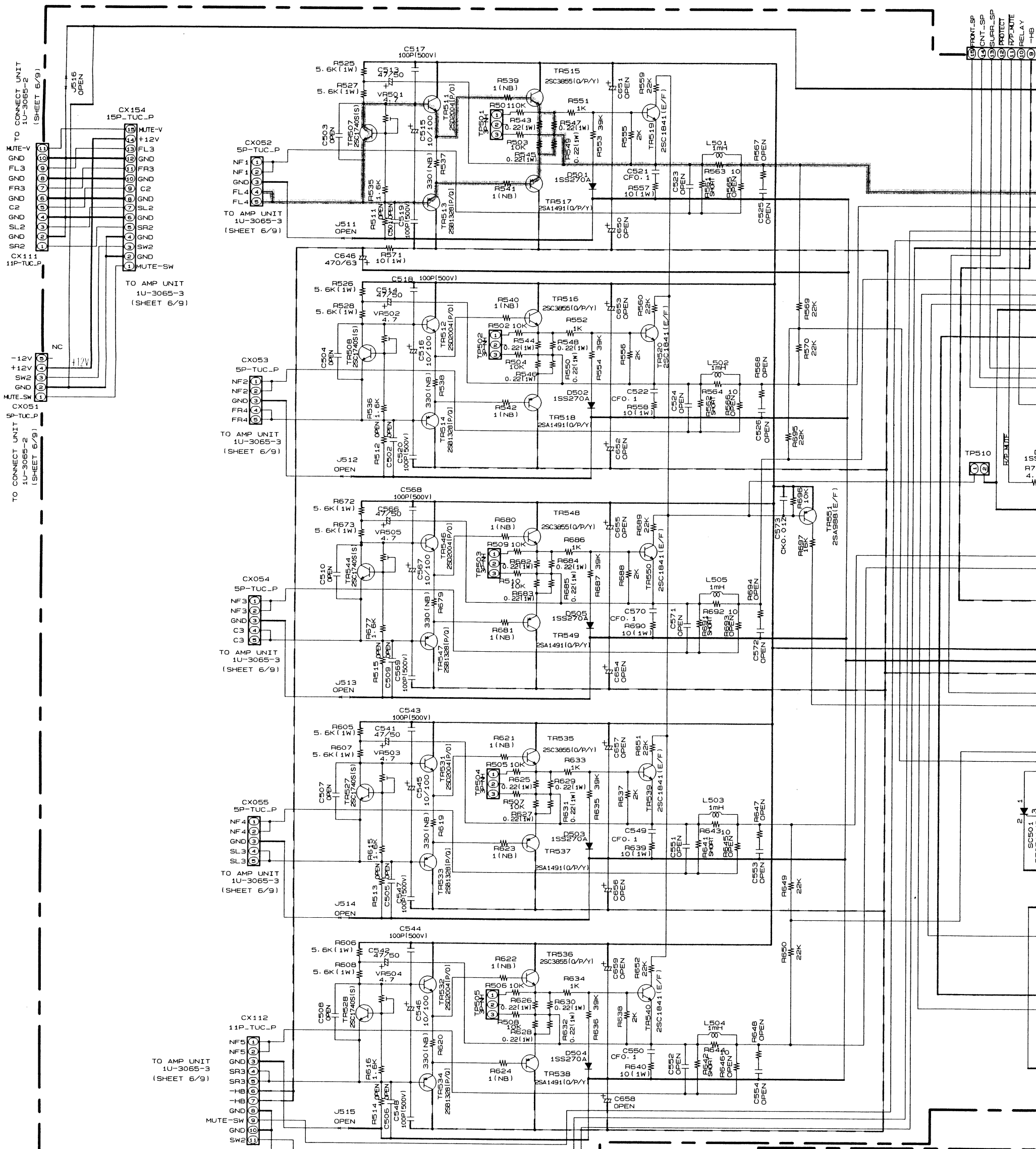

1U-3066-1 POWER UNIT

	*1	*2	*3	*4	*5	*6	*7	*8
	F1	F8	F503, F504	T501	CX023	AC601	R734	JK502
* USA	6.3A/125V 2061045001	8A/125V 2061045014	2A/125V 2061039063	2336073000	—	2P AC OUTLET	2.2M	N1
ASIA	2.5A/250V 2061015032	2.5A/250V 2061015032	2A/250V 2061015061	2336058009	2P VH	—	—	AU
EUROPE	2.5A/250V 2061015032	2.5A/250V 2061015032	2A/250V 2061015061	2336058009	2P VH	—	—	N1
JAPAN	—	8A/125V 2061052008	—	—	—	2P AC OUTLET	—	N1

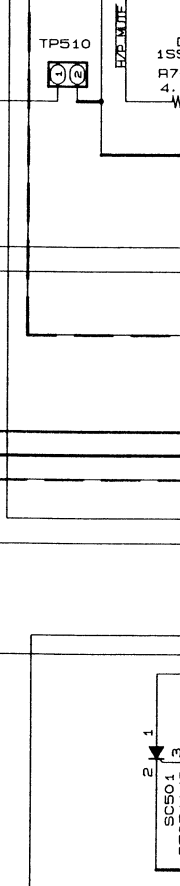
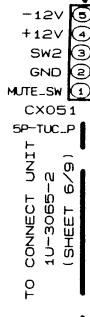
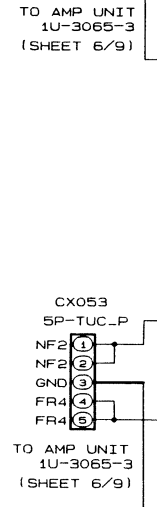
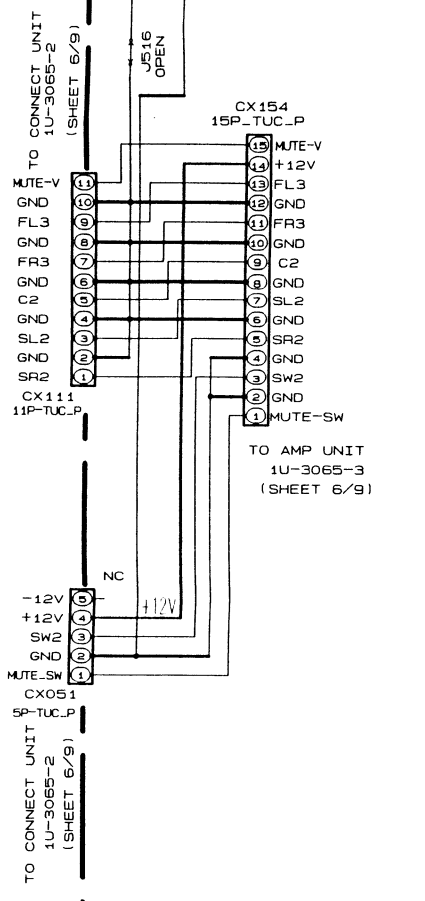
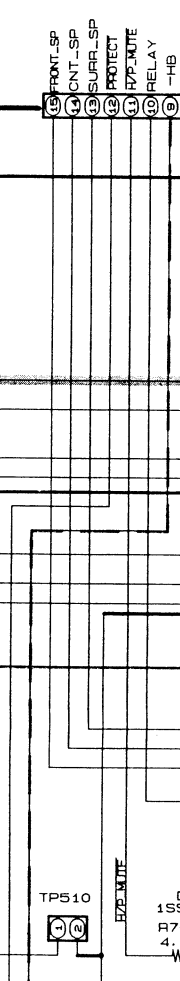
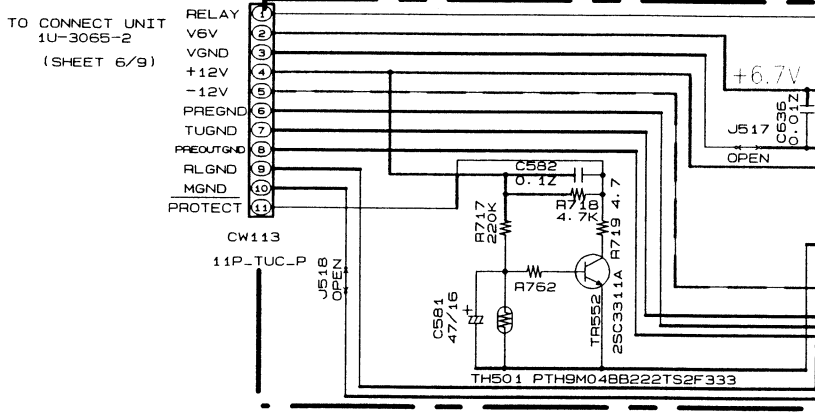

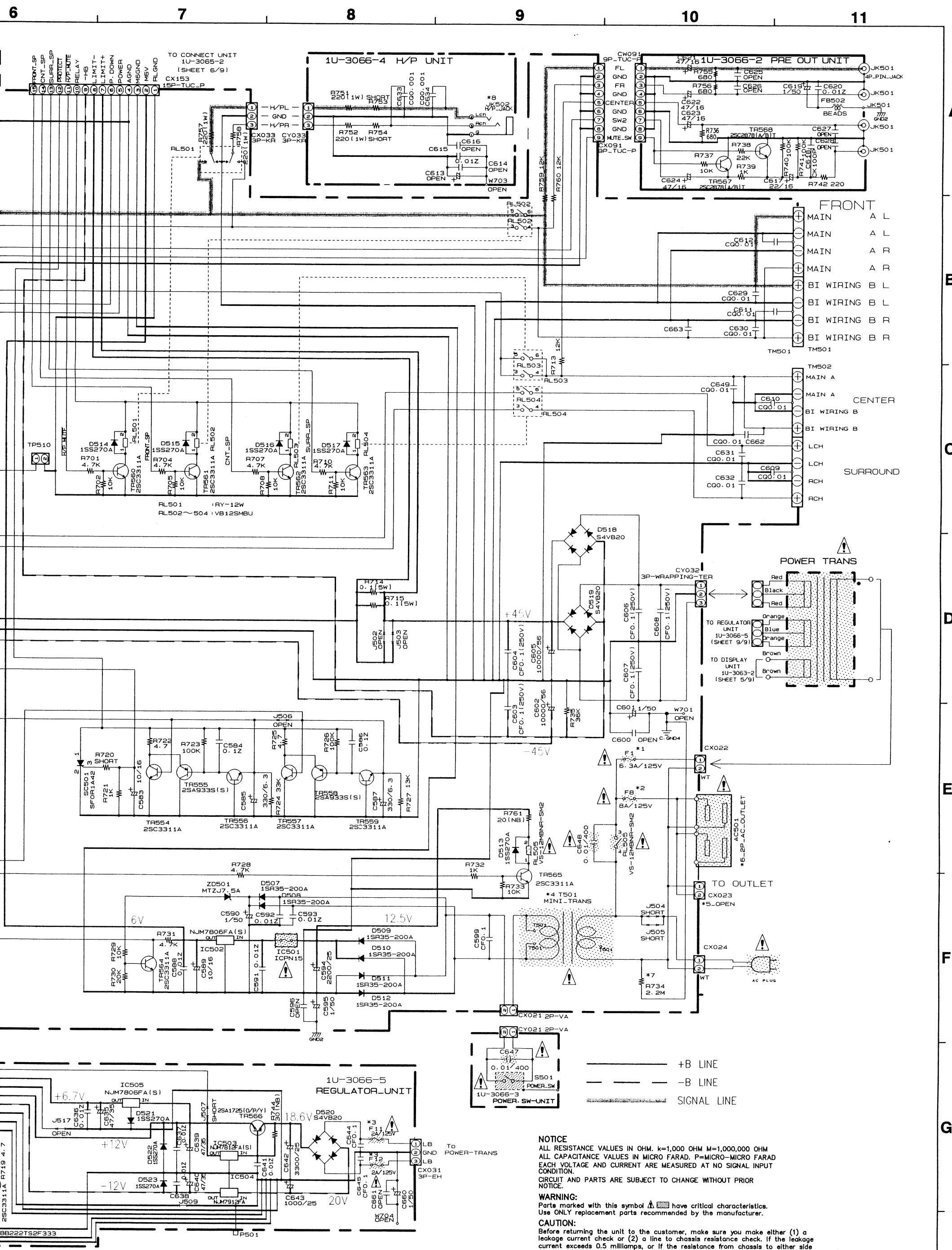

NOTICE
 ALL RESISTANCE VALUES IN OHM. K=1,000 OHM M=1,000,000 OHM
 ALL CAPACITANCE VALUES IN MICRO FARAD. P=MICRO-MICRO FARAD
 EACH VOLTAGE AND CURRENT ARE MEASURED AT NO SIGNAL INPUT
 CONDITION.
 CIRCUIT AND PARTS ARE SUBJECT TO CHANGE WITHOUT PRIOR
 NOTICE.

WARNING:
 Parts marked with this symbol  have critical characteristics.
 Use ONLY replacement parts recommended by the manufacturer.

CAUTION:
 Before returning the unit to the customer, make sure you make either (1) a
 leakage current check or (2) a line to chassis resistance check. If the leakage
 current exceeds 0.5 milliamperes, or if the resistance from chassis to either side
 of the power cord is less than 240 kohms, the unit is defective.

WARNING:
 DO NOT return the unit to the customer until the problem is located and
 corrected.

SCHEMATIC DIAGRAM (7/9)

SCHEMATIC DIAGRAM (8/9)

1 2 3 4 5

A
B
C
D
E
F
G
H

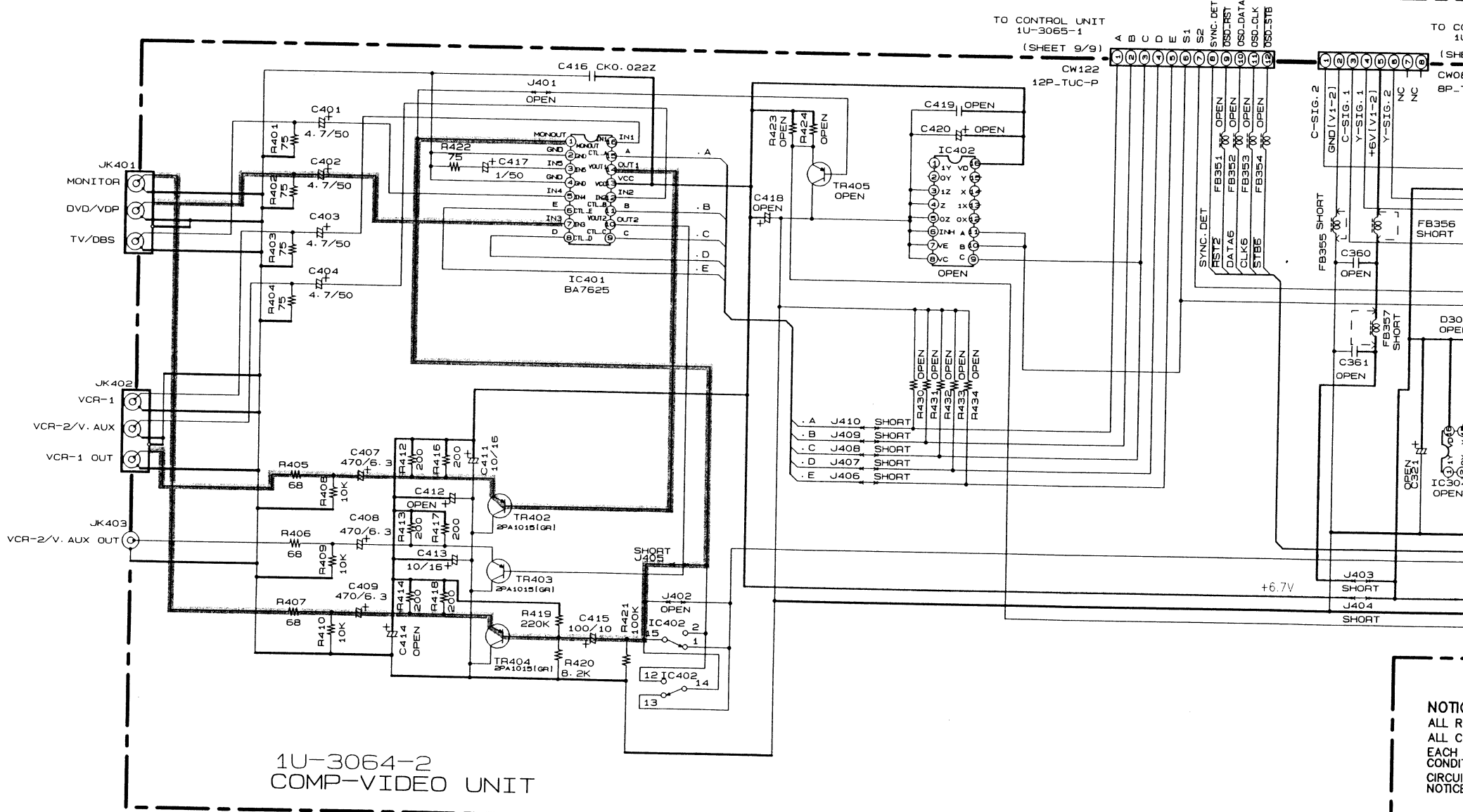
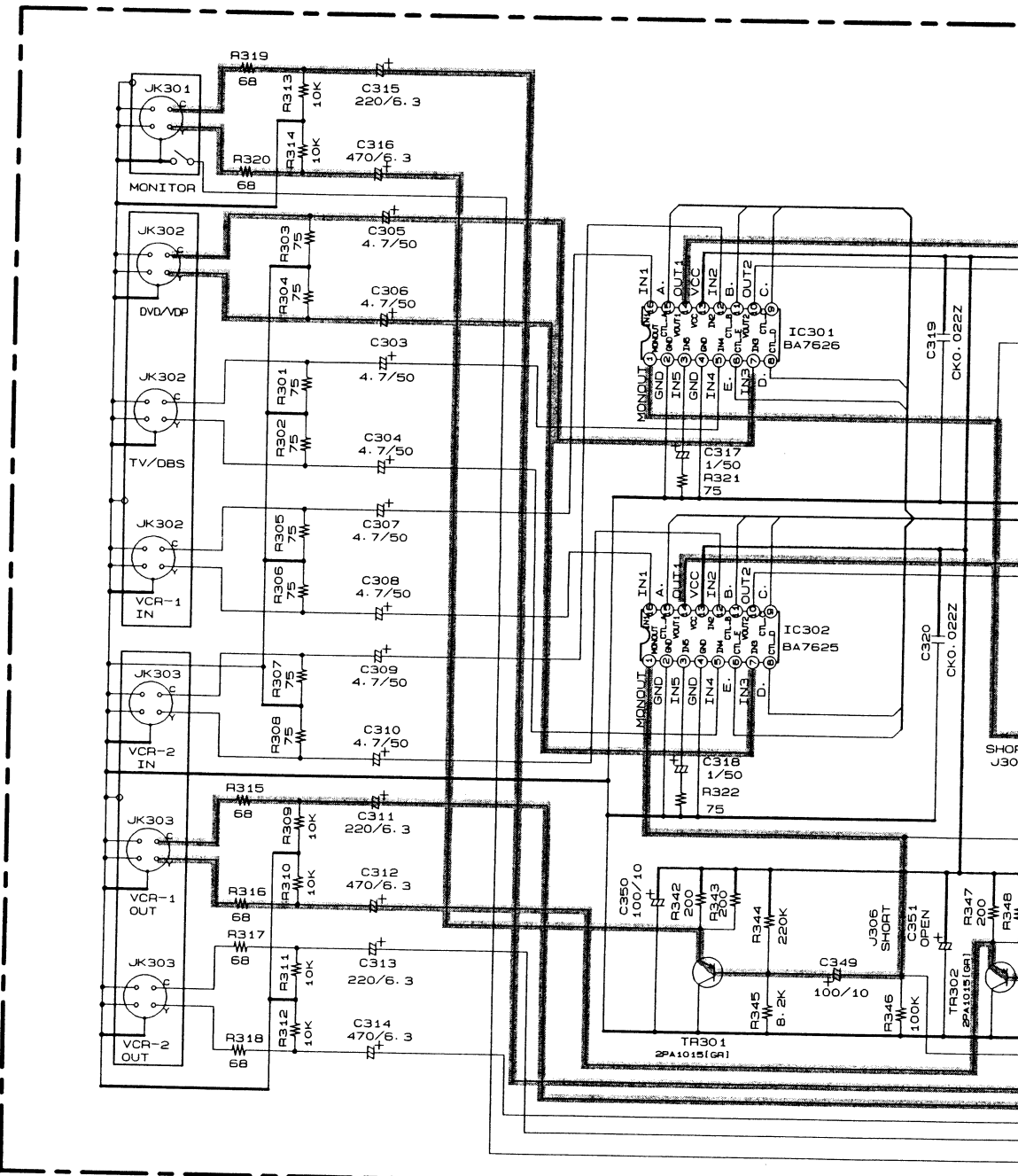

1U-3064-2
COMP-VIDEO UNIT

TO CONTROL UNIT
1U-3065-1
(SHEET 9/9)
CW122
12P-TUC-P

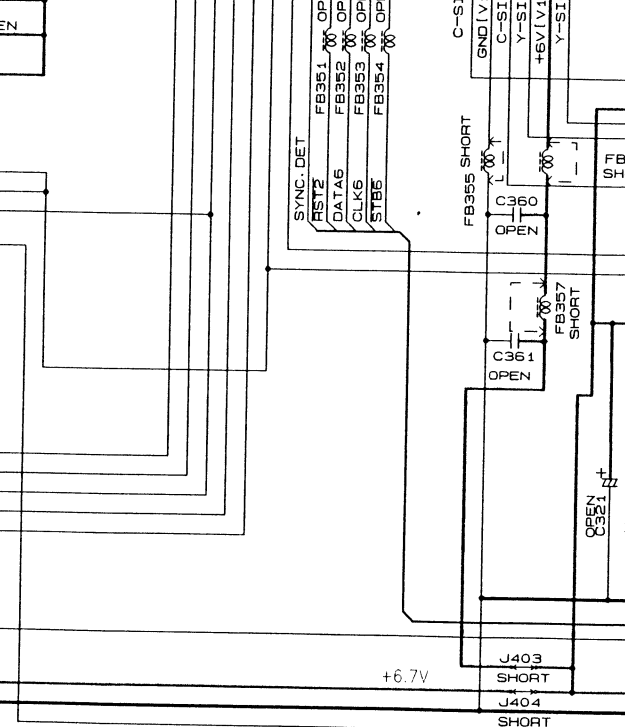
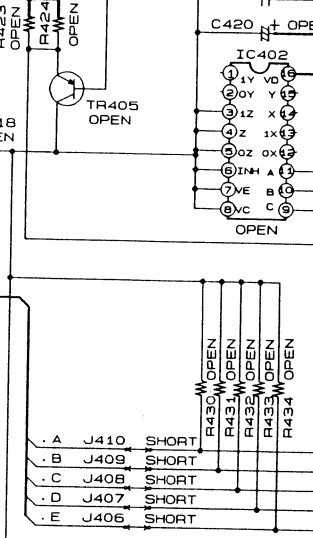

NOTICE
ALL R...
ALL C...
EACH...
CIRCUIT...
NOTICE

1U-3064-3
S-VIDEO UNIT
(AVR2200/2220 only)

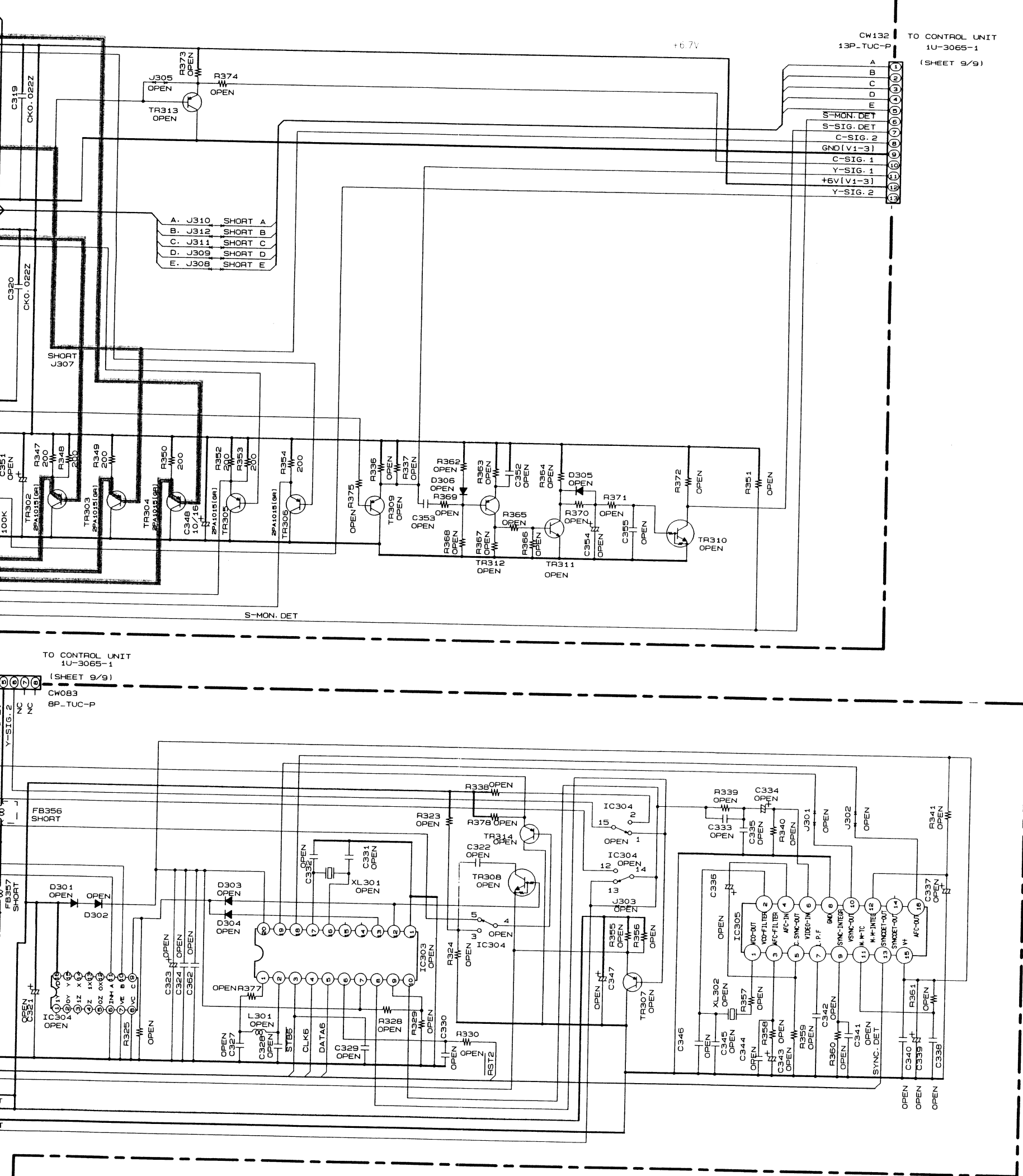

- A. J310 SHORT A
- B. J312 SHORT B
- C. J311 SHORT C
- D. J309 SHORT D
- E. J308 SHORT E

TO CONTROL UNIT
1U-3065-1
(SHEET 9/9)

CW132 TO CONTROL UNIT
13P-TUC-P
1U-3065-1
(SHEET 9/9)

NOTICE
ALL RESISTANCE VALUES IN OHM. k=1,000 OHM M=1,000,000 OHM
ALL CAPACITANCE VALUES IN MICRO FARAD. P=MICRO-MICRO FARAD
EACH VOLTAGE AND CURRENT ARE MEASURED AT NO SIGNAL INPUT
CONDITION.
CIRCUIT AND PARTS ARE SUBJECT TO CHANGE WITHOUT PRIOR
NOTICE.

WARNING:
Parts marked with this symbol have critical characteristics.
Use ONLY replacement parts recommended by the manufacturer.

CAUTION:
Before returning the unit to the customer, make sure you make either (1) a
leakage current check or (2) a line to chassis resistance check. If the leakage
current exceeds 0.5 millamps, or if the resistance from chassis to either side
of the power card is less than 240 kohms, the unit is defective.

WARNING:
DO NOT return the unit to the customer unit the problem is located and
corrected.

— +B LINE
— SIGNAL LINE

SCHEMATIC DIAGRAM (9/9)

1

2

3

4

5

6

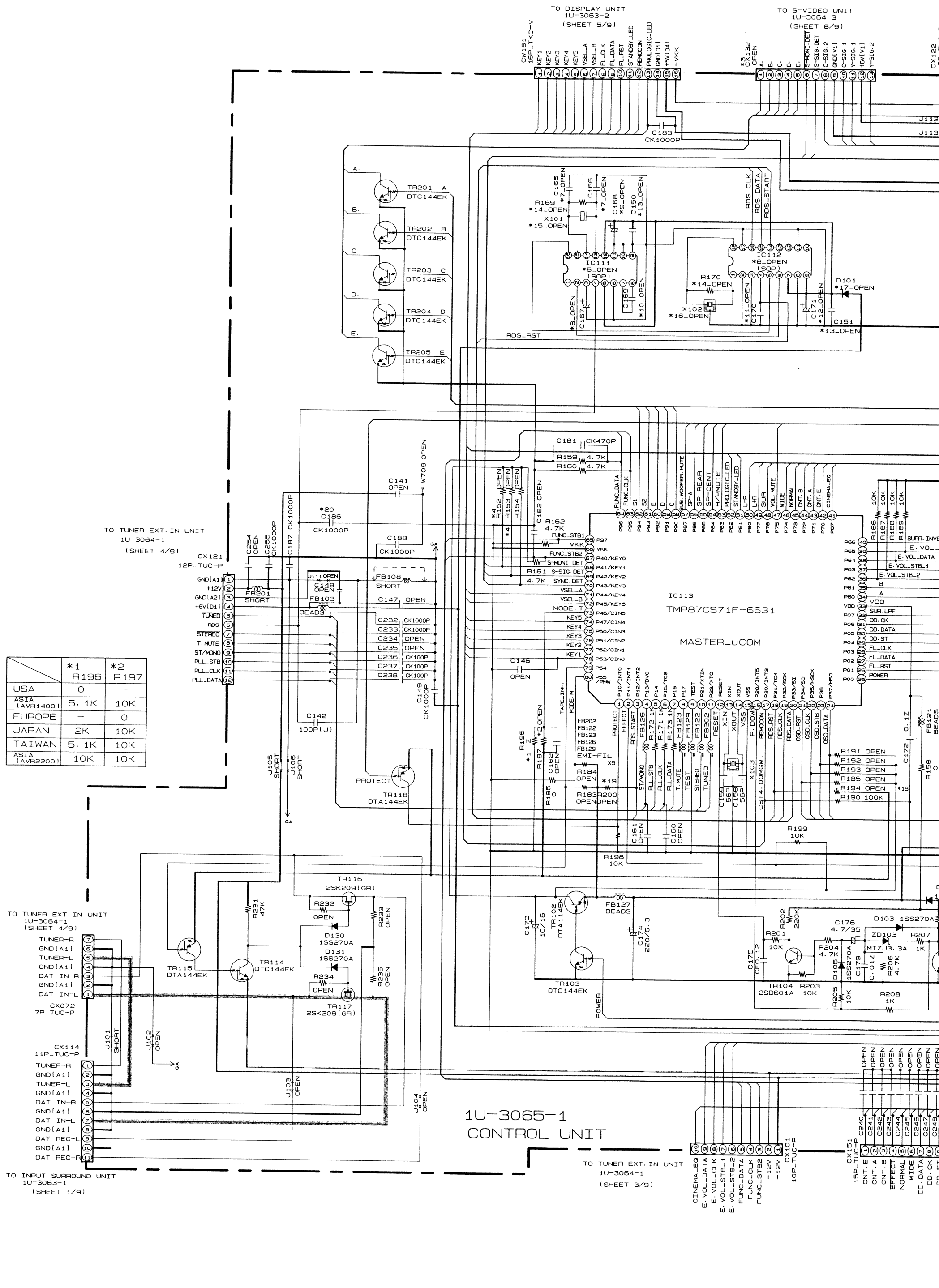

TO TUNER EXT. IN UNIT
1U-3064-1
(SHEET 4/9)

TO TUNER EXT. IN UNIT
1U-3064-1
(SHEET 4/9)

TO TUNER EXT. IN UNIT
1U-3064-1
(SHEET 4/9)

TUNER-R
GND(A1)
TUNER-L
GND(A1)
DAT IN-R
GND(A1)
DAT IN-L
GND(A1)
DAT REC-L
GND(A1)
DAT REC-R

CX072
7P_TUC-P

CX114
11P_TUC-P

TUNER-R
GND(A1)
TUNER-L
GND(A1)
DAT IN-R
GND(A1)
DAT IN-L
GND(A1)
DAT REC-L
GND(A1)
DAT REC-R

TO INPUT SURROUND UNIT
1U-3063-1
(SHEET 1/9)

	*1 R196	*2 R197
USA	0	-
ASIA (AVR1400)	5.1K	10K
EUROPE	-	0
JAPAN	2K	10K
TAIWAN	5.1K	10K
ASIA (AVR2200)	10K	10K

**1U-3065-1
CONTROL UNIT**

TO TUNER EXT. IN UNIT
1U-3064-1
(SHEET 3/9)

TO DISPLAY UNIT
1U-3063-2
(SHEET 5/9)

TO S-VIDEO UNIT
1U-3064-3
(SHEET 8/9)

TO TUNER EXT. IN UNIT
1U-3064-1
(SHEET 3/9)

TO TUNER EXT. IN UNIT
1U-3064-1
(SHEET 3/9)

6 7 8 9 10 11

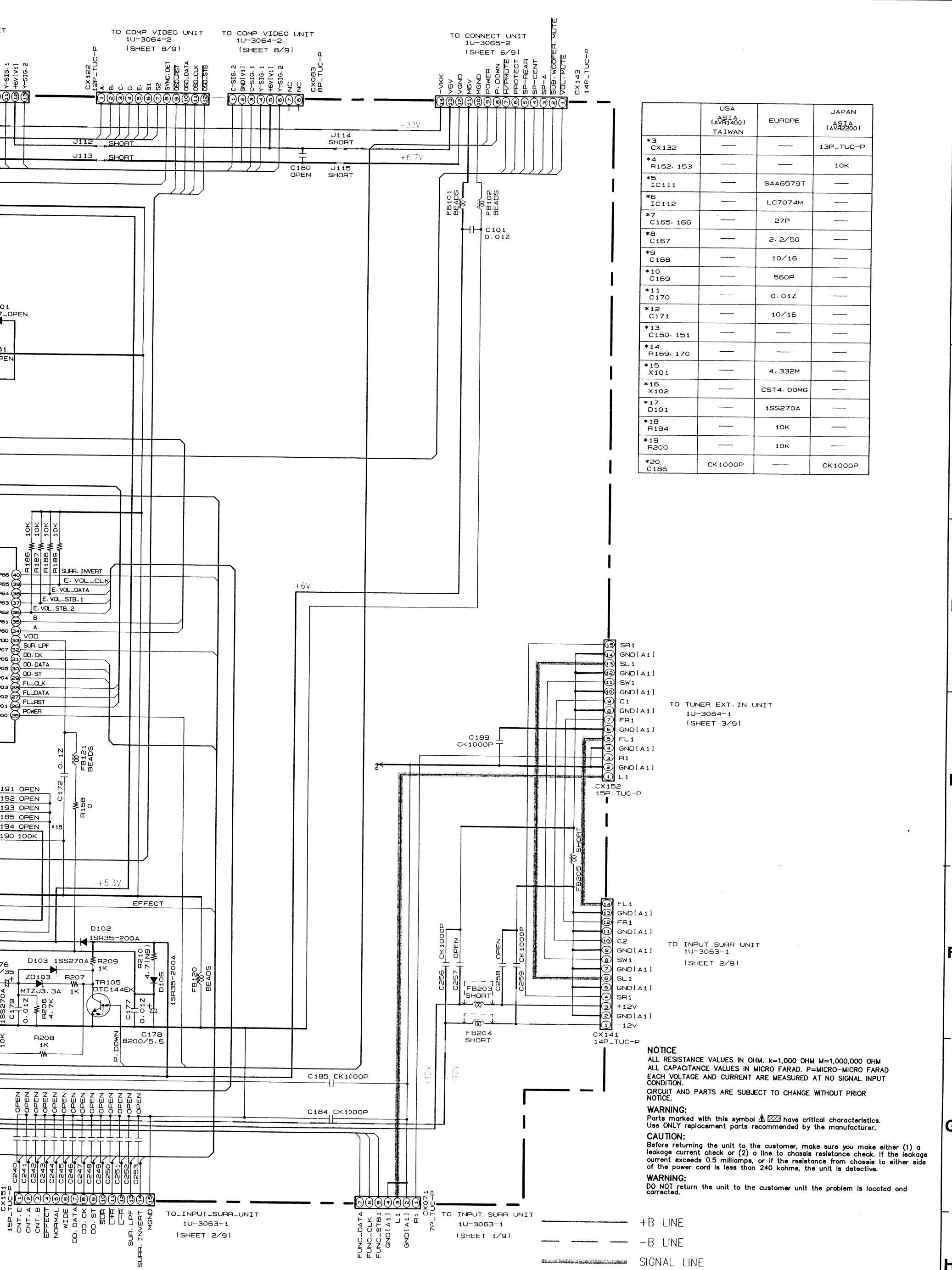

	USA (AVR1400) TAIWAN	EUROPE	JAPAN (AVR2200)
*3 CX132	—	—	13P_TUC-P
*4 R152, 153	—	—	10K
*5 IC111	—	SAA6579T	—
*6 IC112	—	LC7074M	—
*7 C165, 166	—	27P	—
*8 C167	—	2.2/50	—
*9 C168	—	10/16	—
*10 C169	—	550P	—
*11 C170	—	0.01Z	—
*12 C171	—	10/16	—
*13 C150, 151	—	—	—
*14 R169, 170	—	—	—
*15 X101	—	4.332M	—
*16 X102	—	CST4.00MG	—
*17 D101	—	1SS270A	—
*18 R194	—	10K	—
*19 R200	—	10K	—
*20 C186	CK1000P	—	CK1000P

TO TUNER EXT. IN UNIT
1U-3064-1
(SHEET 3/9)

TO INPUT SURR UNIT
1U-3063-1
(SHEET 2/9)

NOTICE
ALL RESISTANCE VALUES IN OHM. k=1,000 OHM M=1,000,000 OHM
ALL CAPACITANCE VALUES IN MICRO FARAD. P=MICRO-MICRO FARAD
EACH VOLTAGE AND CURRENT ARE MEASURED AT NO SIGNAL INPUT
CONDITION.
CIRCUIT AND PARTS ARE SUBJECT TO CHANGE WITHOUT PRIOR
NOTICE.

WARNING:
Parts marked with this symbol have critical characteristics.
Use ONLY replacement parts recommended by the manufacturer.

CAUTION:
Before returning the unit to the customer, make sure you make either (1) a
leakage current check or (2) a line to chassis resistance check. If the leakage
current exceeds 0.5 milliamperes, or if the resistance from chassis to either side
of the power cord is less than 240 kohms, the unit is defective.

WARNING:
DO NOT return the unit to the customer until the problem is located and
corrected.

—+B LINE
- - - -B LINE
——— SIGNAL LINE

SCHEMATIC DIAGRAM (9/9)

A
B
C
D
E
F
G
H

REMOTE CONTROL UNIT (RC-832)

1 2 3 4 5 6 7 8

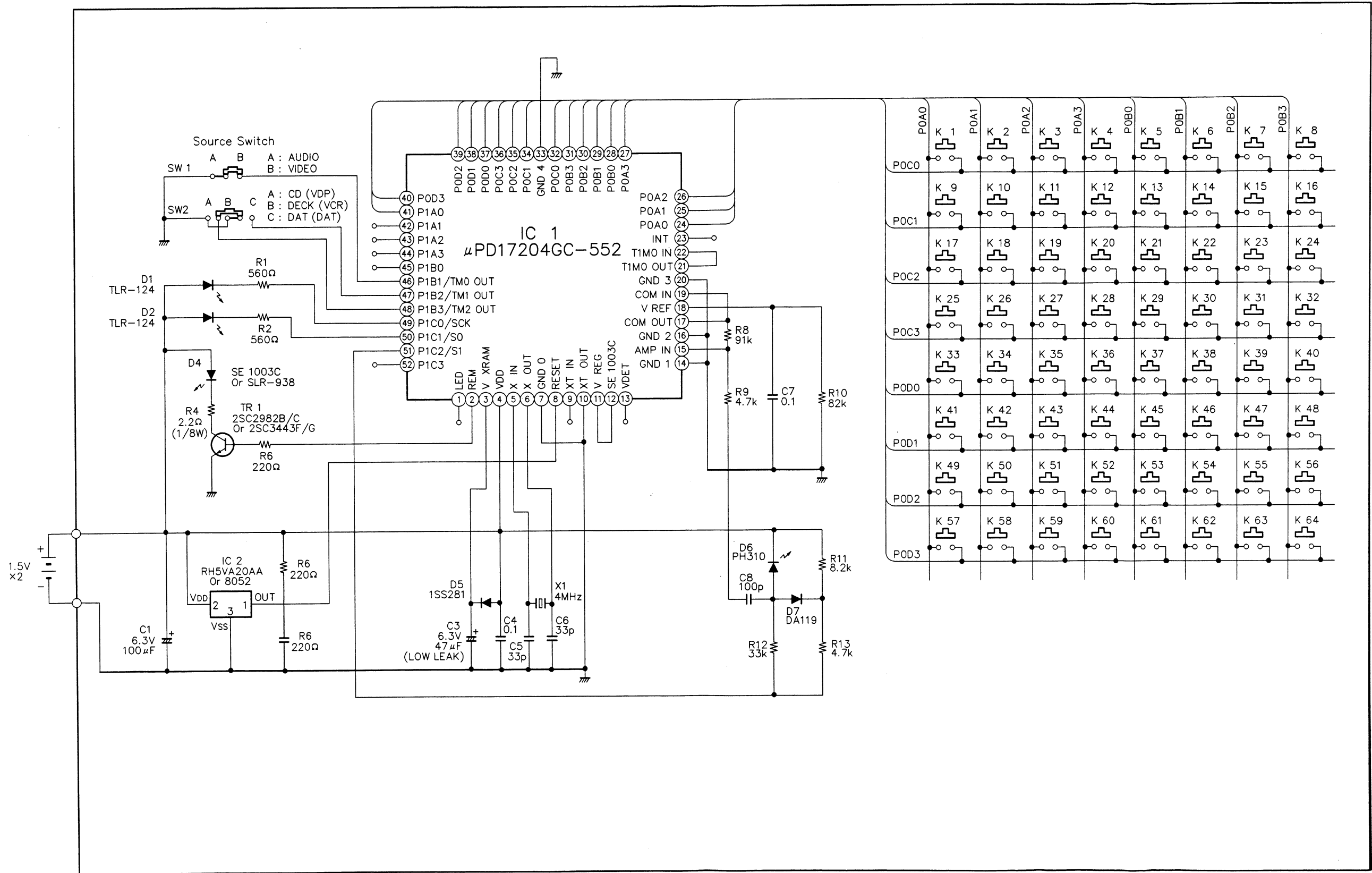

A
B
C
D
E

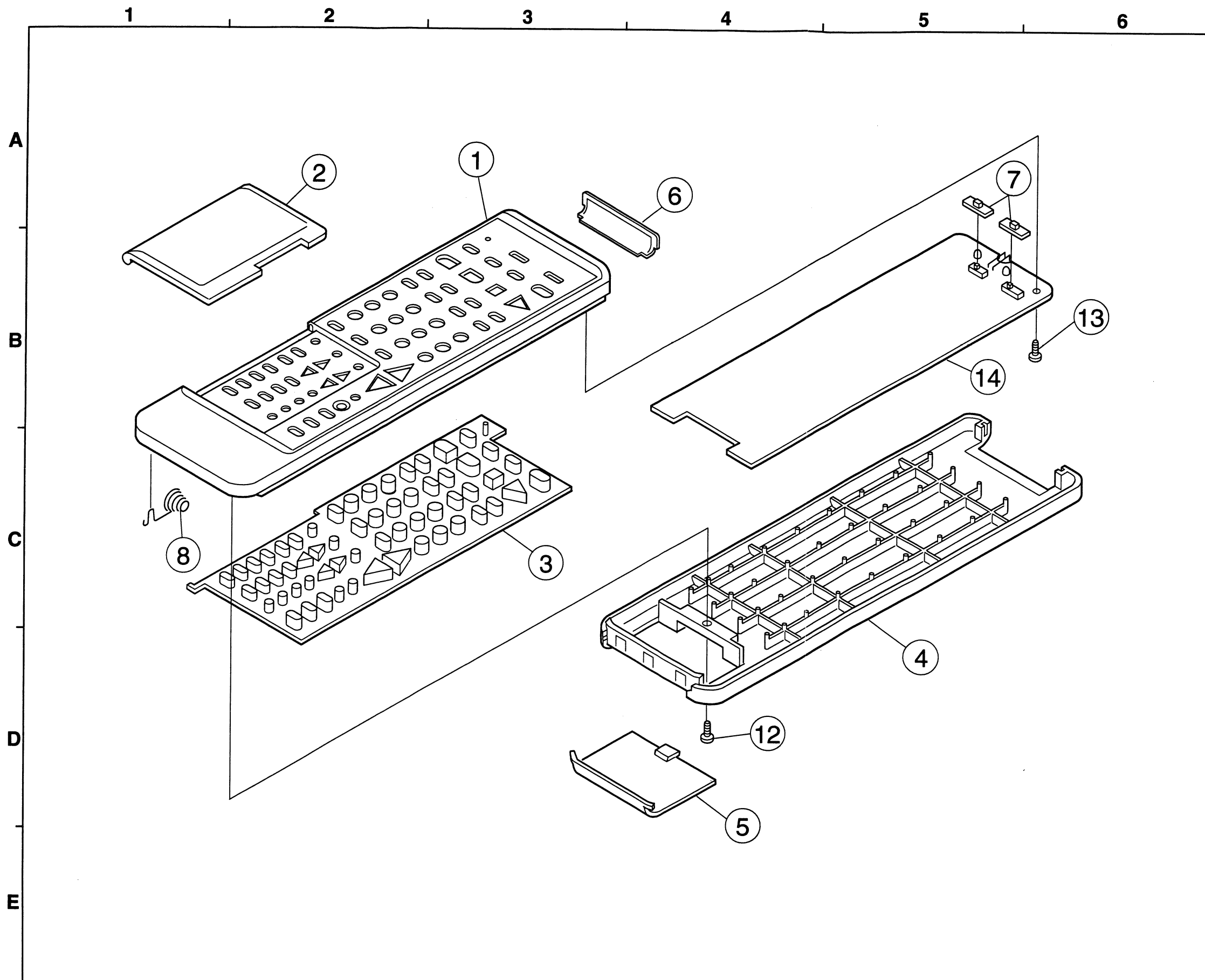

PARTS LIST OF REMOTE CONTROL UNIT (RC-832)

Ref. No.	Part No.	Part Name	Remarks	Q'ty
● 1	9H3 1000 170	Top Case (RC832) Ass'y		1s
● 2	9H3 1000 168	Cover		1
● 3	9H3 1000 169	Switch Rubber		1
● 4	9H3 1000 166	Bottom Case		1
● 5	9H3 1000 167	Battery Cover		1
● 6	9H3 1000 148	Filter		1
● 7	9H3 1000 150	Slide Knob		2
● 8	9H3 1000 152	Coil Spring		1
9	—	—		
10	—	—		
11	—	—		
12	9H3 1000 154	Tapping Screw 2x6		1
13	9H3 1000 107	Tapping Screw 2x5		1
14	9H3 1000 161	Main P.W.B. Ass'y		1s
IC1	9H3 1000 162	IC μ PD17204GC-552	μ -Com	1
IC2	9H3 1000 158	IC RH5VA10AA	vol. Detector	1
Q1	9H3 1000 070	Transistor 2SC2982	Chip	1
D1,2	9H3 1000 028	LED TLR124	Visible-Red	2
D4	9H3 1000 131	LED SE1003-C	Infrared	1
D5	9H3 1000 087	Diode 1SS2B1		1
D6	9H3 1000 029	Diode PH310	Photo-PIN	1
D7	9H3 1000 071	Diode DA119	Chip	1
X1	9H3 1000 088	Ceramic Resonator	KBR4, 0M503	1
SW1	9H3 1000 089	Slide Switch		1
SW2	9H3 1000 074	Slide Switch		1
C1	254 4213 034	Electrolytic 100 μ F/6.3V	CE04W0J101 M	1
C3	254 4213 021	Electrolytic 47 μ F/6.3V	CE04W0J470M	1