

DENON

Hi-Fi Component

SERVICE MANUAL

MODEL AVR-1601/681

AV SURROUND RECEIVER

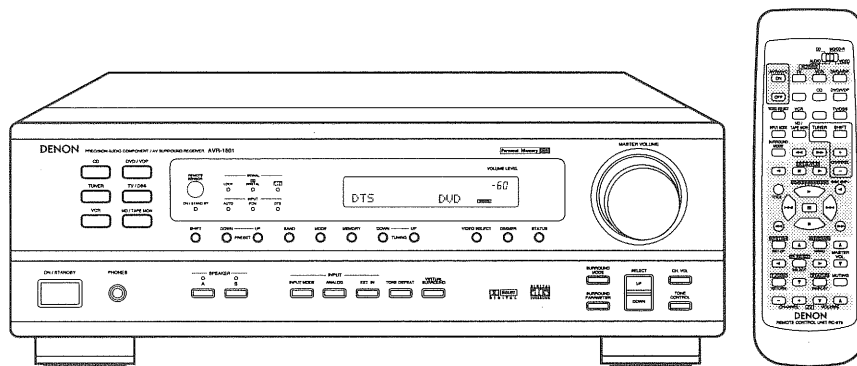

— TABLE OF CONTENTS —

SAFETY PRECAUTIONS	2
SPECIFICATIONS	2
DISASSEMBLY	3
CLOCK FLOW	4
LEVEL DIAGRAM	5,6
BLOCK DIAGRAM	7
ADJUSTMENT	8
SEMICONDUCTORS	9~15
PRINTED WIRING BOARDS	16~23
NOTE FOR PARTS LIST	24
PARTS LIST OF P.W.B. UNIT ASS'Y	25~37
EXPLODED VIEW	38
PARTS LIST OF EXPLODED VIEW	39
WIRING DIAGRAM	40
SCHEMATIC DIAGRAMS	41~48
(1/8) MAIN UNIT / VOLTAGE SEL UNIT	41
(2/8) INPUT UNIT	42
(3/8) FRONT UNIT / TACT SW UNIT / H/P, POWER SW UNIT	43
(4/8) CPU UNIT / PRE-AMP UNIT	44
(5/8) CNT UNIT	45
(6/8) VIDEO UNIT / S-VIDEO UNIT	46
(7/8) TUNER UNIT	47
(8/8) DSP UNIT	48
PACKING VIEW	49
PARTS LIST OF PACKING & ACCESSORIES	49

• Some illustrations using in this service manual are slightly different from the actual set.

NIPPON COLUMBIA CO., LTD.

SAFETY PRECAUTIONS

The following check should be performed for the continued protection of the customer and service technician.

LEAKAGE CURRENT CHECK

Before returning the unit to the customer, make sure you make either (1) a leakage current check or (2) a line to chassis resistance check. If the leakage current exceeds 0.5 milliamps, or if the resistance from chassis to either side of the power cord is less than 460 kohms, the unit is defective.

SPECIFICATIONS

Audio Section

Power Amplifier

Rated output:

Front:	60W+60W	(8Ω/ohms, 20Hz~20kHz with 0.08% T.H.D)
	90W+90W	(6Ω/ohms, 1kHz with 0.7% T.H.D) (U.S.A., Canada & Europe Models)
	100W+100W	(6Ω/ohms, EIAJ) (Asia Model)
Center:	60W	(8Ω/ohms, 20Hz~20kHz with 0.08% T.H.D)
	90W	(6Ω/ohms, 1kHz with 0.7% T.H.D) (U.S.A., Canada & Europe Models)
	100W	(6Ω/ohms, EIAJ) (Asia Model)
Surround:	60W+60W	(8Ω/ohms, 20Hz~20kHz with 0.08% T.H.D)
	90W+90W	(6Ω/ohms, 1kHz with 0.7% T.H.D) (U.S.A., Canada & Europe Models)
	100W+100W	(6Ω/ohms,EIAJ) (Asia Model)

Output terminals:

Front:	A or B 6 to 16Ω/ohms
	A+B 12 to 16Ω/ohms
Center/Surround:	6 to 16Ω/ohms

Analog

LINE input - PRE OUT

Input sensitivity/input impedance: 200mV/47kΩ/kohms

Frequency response: 10Hz~100kHz: +1, -3dB (TONE DEFEAT ON)

S/N ratio: 98dB (IHF-A weighted)(TONE DEFEAT ON)

Video Section

Standard video jacks

Input/output level and impedance: 1Vp-p,75Ω/ohms

Frequency response: 5Hz~10MHz — +1, -3dB

S-video jacks (U.S.A., Canada & Asia Models)

Input/output level and impedance: Y(brightness)signal — 1Vp-p, 75Ω/ohms

C(color)signal — 0.286Vp-p, 75Ω/ohms

Frequency response: 5Hz~10MHz: — +1, -3dB

Tuner section

Receiving range:

U.S.A., Canada &

Asia (for Multiple voltage) Models: 87.50MHz~107.90MHz

Europe & Asia (for China) Models: 87.50MHz~108.00MHz

Usable sensitivity:

50 dB quieting sensitivity:

MONO 1.6μV (15.3dBf)

STEREO 23μV (38.5dBf)

MONO 80dB (IHF-A weighted)

STEREO 75dB (IHF-A weighted)

MONO 0.15% (1kHz)

STEREO 0.3% (1kHz)

[FM] (note: μV at 75Ω/ohms, 0dBf = 1×10^{-15} W)

[AM]

520kHz~1710kHz

522kHz~1611kHz

18μV

General

Power supply:

U.S.A., Canada Models

AC120V,60Hz

Europe Model

AC230V,50Hz

Asia(for Multiple voltage)Model

AC115/230V,50/60Hz

Asia(for China)Model

AC220V,50Hz

Power consumption:

200W

Maximum external dimensions:

434 (W) × 147 (H) × 417 (D) mm (17-3/32" × 5-25/32" × 16-7/16")

Mass:

9.5kg (20 lbs 15.1 oz)

Remote control unit (RC-875)

Batteries:

R6P/AA Type (two batteries)

External dimensions:

54 (W) × 172 (H) × 27.2 (D) mm (2-1/8" × 6-49/642" × 1-5/64")

Mass:

100g (Approx. 6 oz) (including batteries)

* For purposes of improvement, specifications and design are subject to change without notice.

DISASSEMBLY

(Follow the procedure below in reverse order when reassembling)

Top Cover

Remove 6 screws ① and 3 screws ②, detach the Top Cover in the arrow direction.

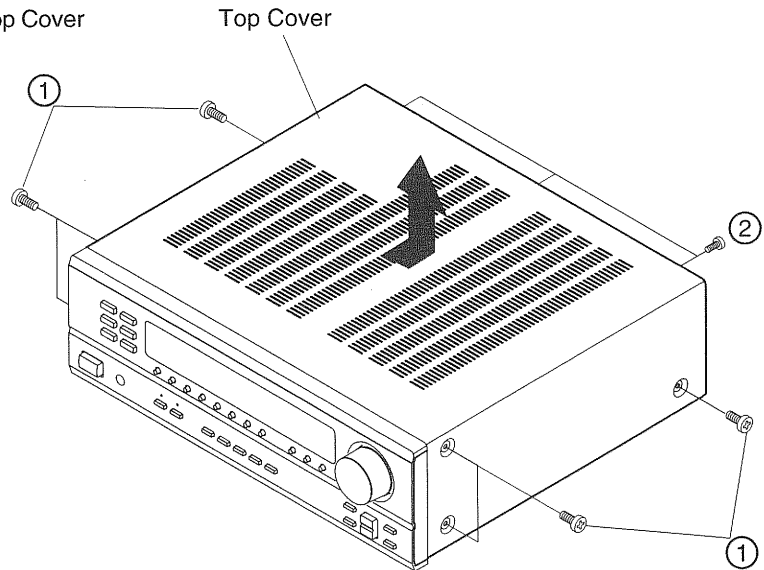

Front Panel

1. Remove 6 screws ③.
2. Detach the Front Panel in the arrow direction.

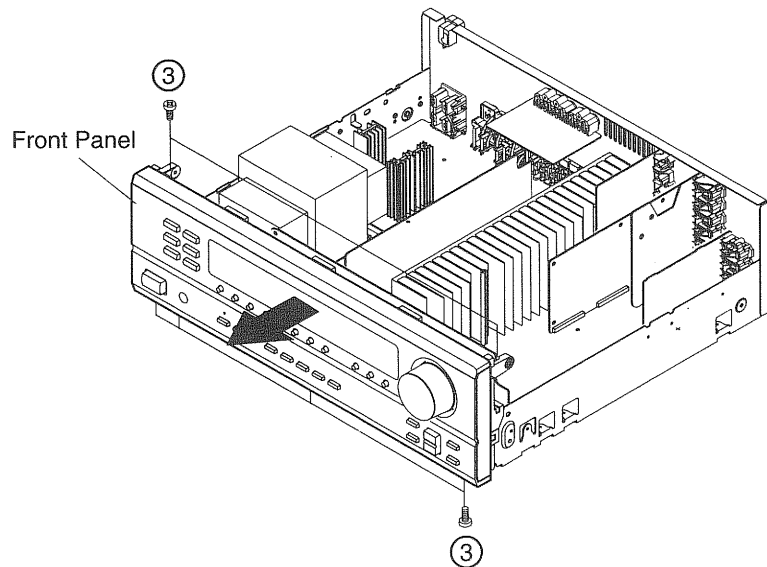

Rear Panel

1. Remove cord bushing ④ from the Rear Panel.
2. Remove 28 screw ⑤.
3. Detach the Rear Panel in the arrow direction.

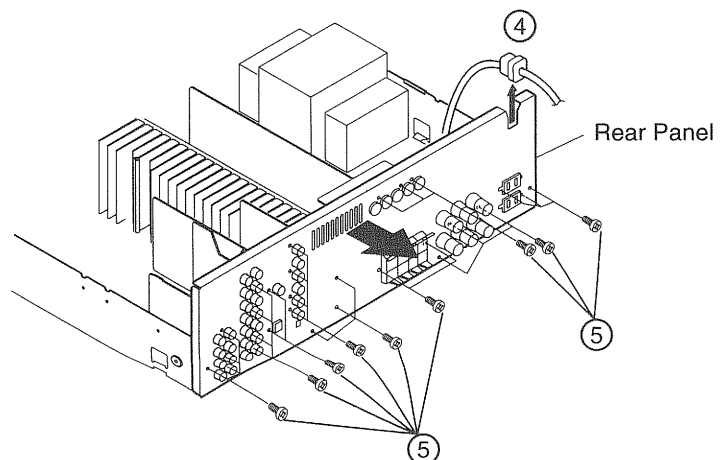

CLOCK FLOW

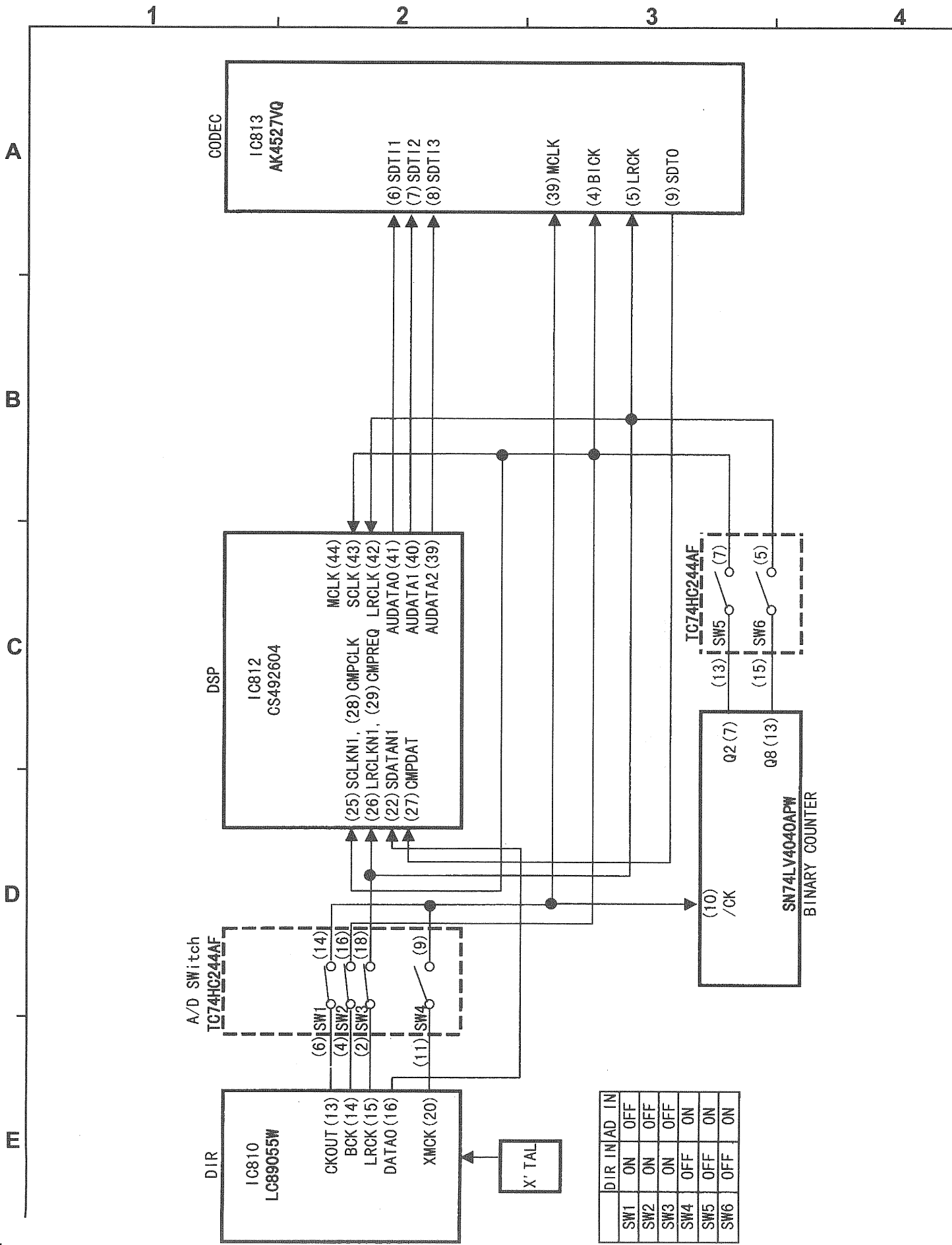

LEVEL DIAGRAM

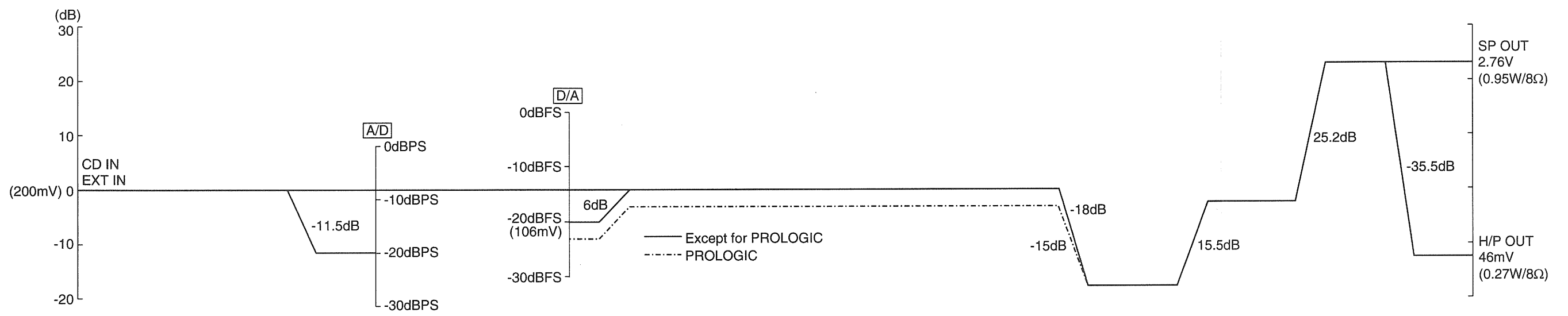
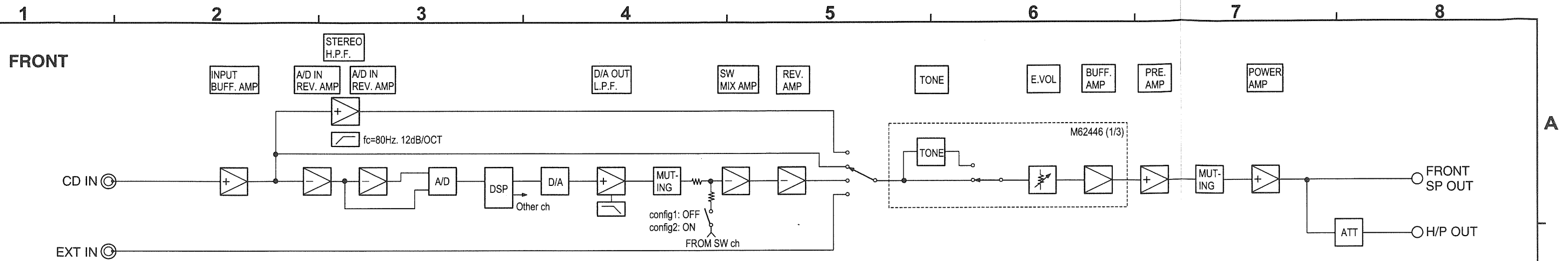

CENTER SURROUND

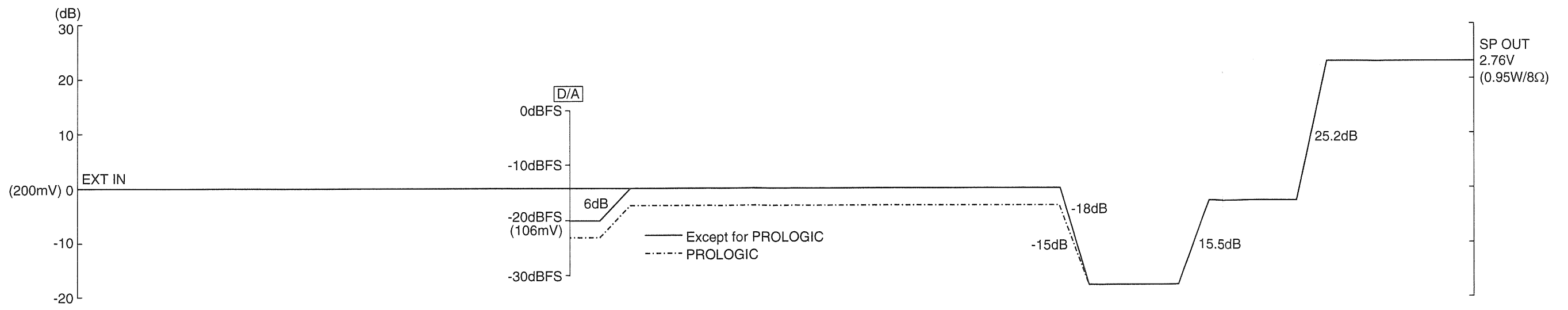
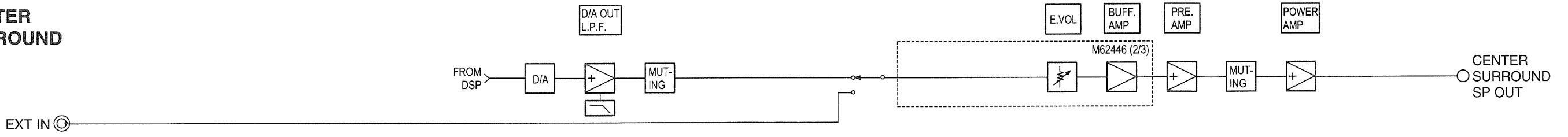

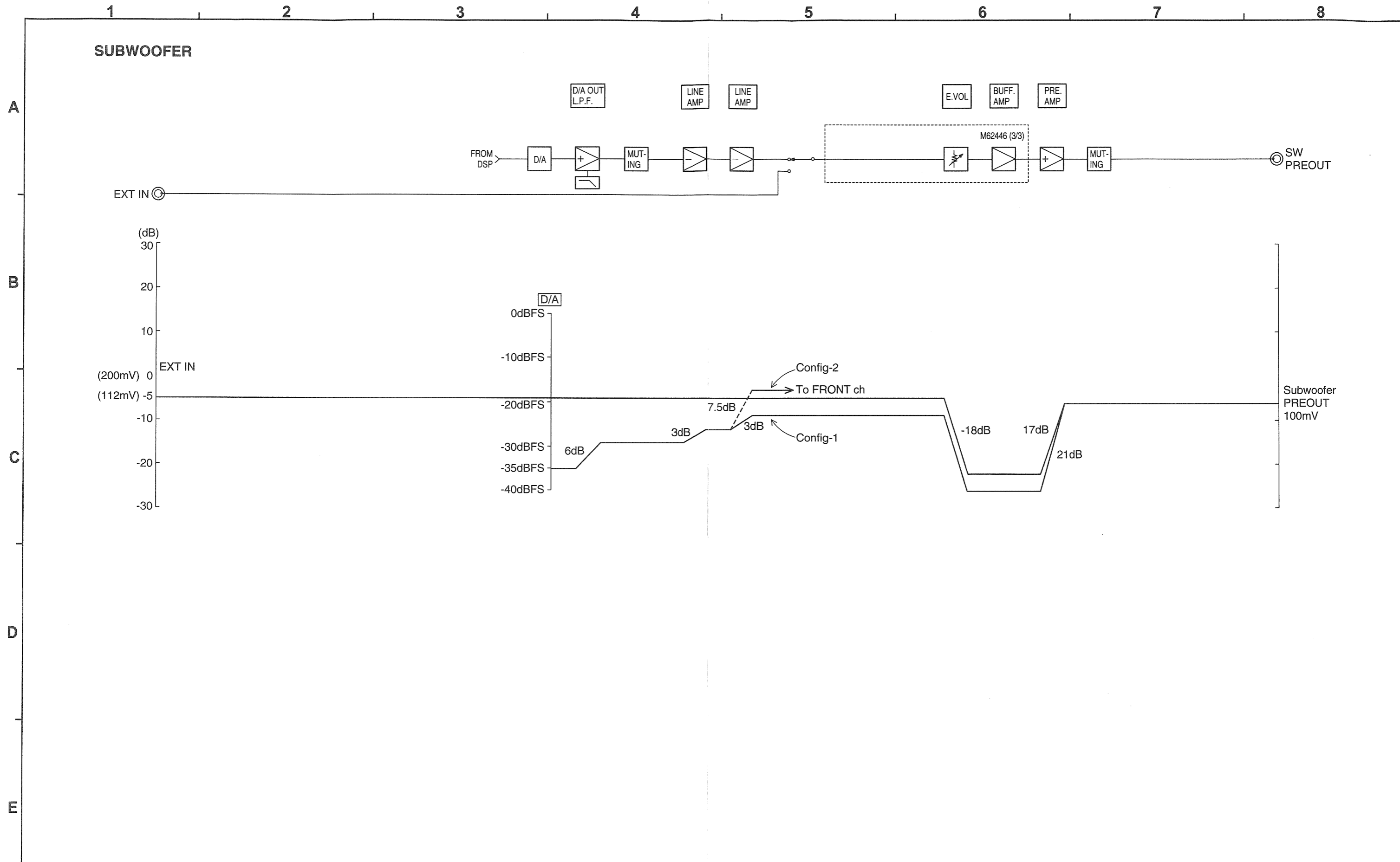

BLOCK DIAGRAM

1 2 3 4 5 6 7 8

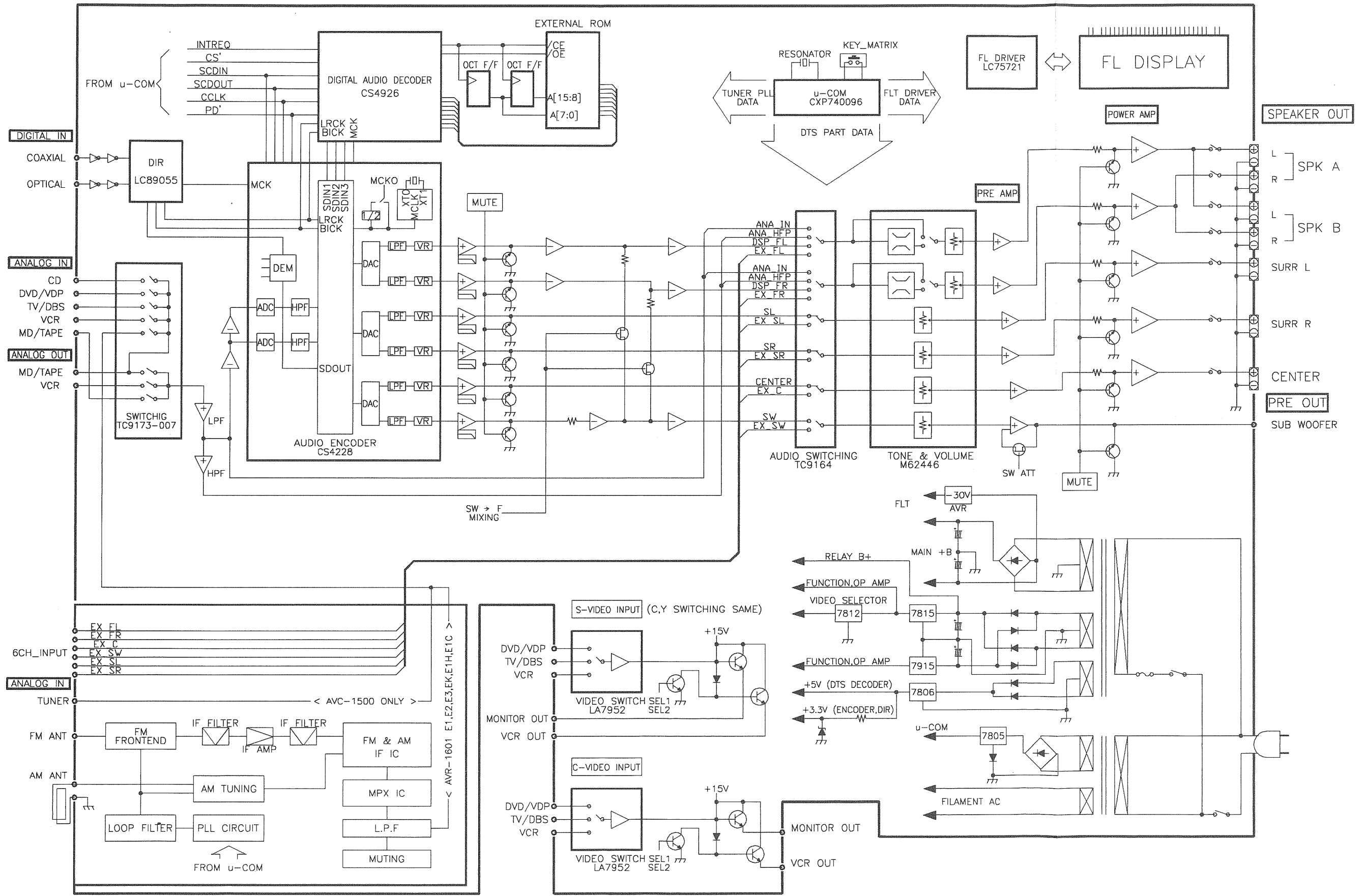

A

B

C

D

E

ADJUSTMENT

Tuner Section

CONNECTION DIAGRAM OF MEASURING INSTRUMENTS

● FM

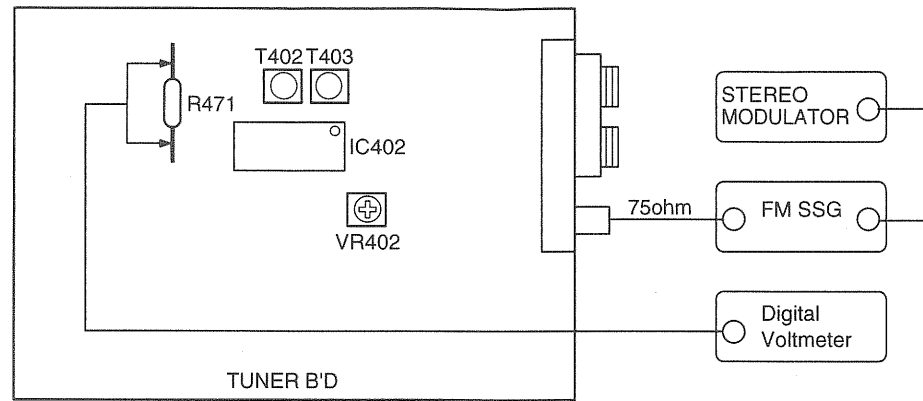

FM ALIGNMENT

Step	Alignment Item	Tuning Frequency Setting	Input					Output		Adjustment	
			Type	Frequency	Input Level	Modulation	Coupling	Type	Connect to	Points	Adjust to
1	Center Adjustment	98.1MHz (98.0MHz)	FM SSG	98.1MHz	60dBμ	Mono 1kHz 100%	Antenna Terminal	Digital Voltmeter	R471	T402	± 50mV
2	Distortion	98.1MHz (98.0MHz)	FM SSG	98.1MHz	60dBμ	Mono 1kHz 100%	Antenna Terminal	Distortion Meter	Output Terminal (L)	T403	Minimum Distortion
3	Repeat Steps 1 and 2										
4	Signal Level	98.1MHz (98.0MHz)	FM SSG	98.1MHz	20dBμ	OFF	Antenna Terminal	Light "TUNED" on FL Display		VR402	20 ± 1/10 dB

● AM

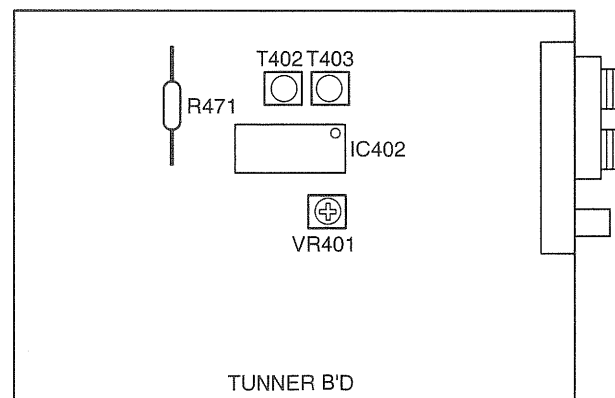

AM ALIGNMENT

Step	Alignment Item	Frequency	Input	Output		Adjustment		Remarks
				Type	Connect to	Points	Adjust to	
1	Signal Level	999 (1000) kHz	AM SSG	—	—	VR401	Light "TUNED" on FL Display	SSG OUTPUT 74dBμ (EMF)

Audio Section

Idling Current

Required measurement equipment : DC Voltmeter

Preparation

- Avoid direct blow from an air conditioner or an electric fan, and adjust the unit at normal room temperature 15 °C ~ 30 °C (59 °F ~ 86 °F).
- Presetting
 - POWER (Power source switch) → OFF
 - SPEAKER (Speaker terminal) → No load (Do not connect speaker, dummy resistor, etc.)

Adjustment

- Remove top cover and set VR101, VR102, VR103, VR104, VR105 on Amp. Unit at full counterclockwise (◯) position.
- Connect DC Voltmeter to test points (FRONT-Lch: TP101, FRONT-Rch: TP102, CENTER ch: TP103, SURROUND-Lch: TP104, SURROUND-Rch: TP105).
- Connect power cord to AC Line, and turn power switch "ON".
- Presetting.
 - MASTER VOLUME : "---" counterclockwise (◯ min.)
 - MODE : 5CH STEREO
 - FUNCTION : CD
- Within 2 minutes after the power on, turn VR101 clockwise (◯) to adjust the TEST POINT voltage to 1.5 mV ±0.5 mV DC.
- After 10 minutes from the preset above, turn VR101 to set the voltage to 2 mV ±0.5 mV DC.
- Adjust the Variable Resistors of other channels in the same way.

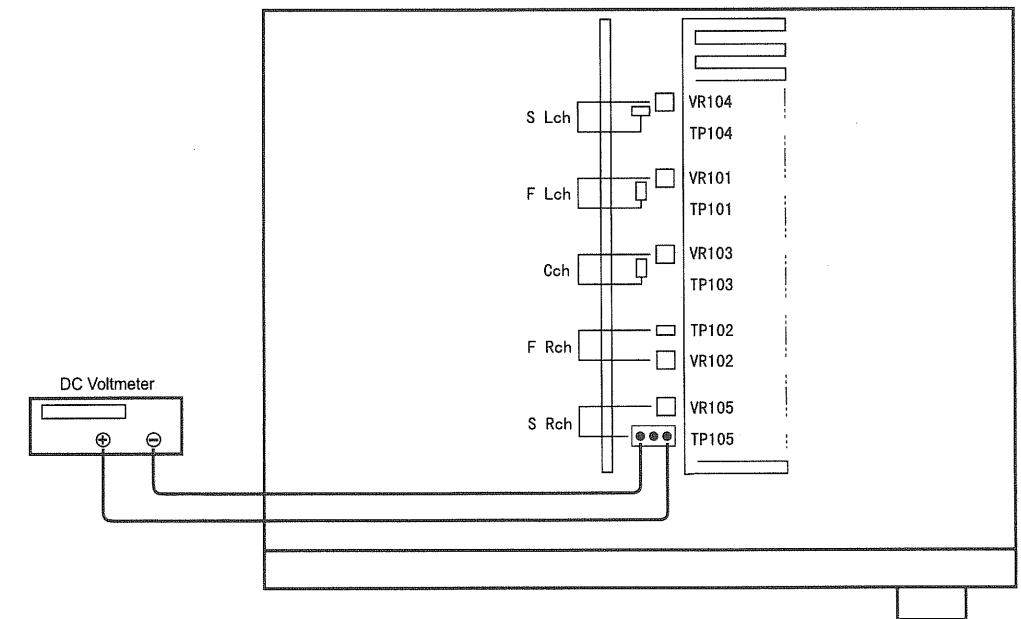

SEMICONDUCTORS

● ICs

CS492604-CLR (AU: IC812)

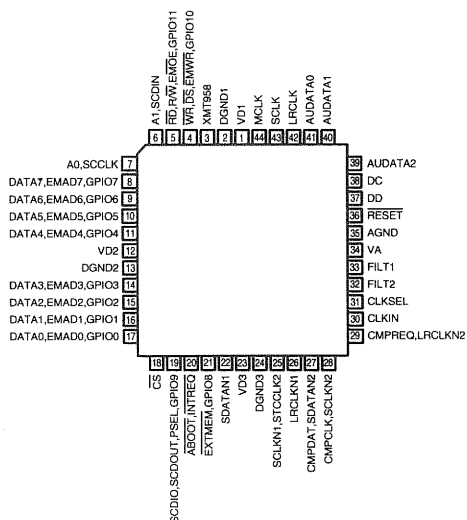

CS492604-CLR Terminal Function

Pin No.	Pin Name	Function
1	VD1	Digital positive supply
2	DGND1	Digital supply ground
3	XMT958	SPDIF transmitter output
4	WR, DS, EMWR, GPIO10	Host write strobe or host data strobe or external memory write enable or general purpose input & output number 10
5	RD, R/W, EMOE, GPIO11	Host parallel output enable or host parallel R/W or external memory output enable or general purpose input & output number 11
6	A1, SCDIN	Host address bit one or SPI serial control data input
7	A0, SCCLK	Host parallel address bit zero or serial control port clock
8	DATA7, EMAD7, GPIO7	
9	DATA6, EMAD6, GPIO6	
10	DATA5, EMAD5, GPIO5	
11	DATA4, EMAD4, GPIO4	
12	VD2	Digital positive supply
13	DGND2	Digital supply ground
14	DATA3, EMAD3, GPIO3	
15	DATA2, EMAD2, GPIO2	
16	DATA1, EMAD1, GPIO1	
17	DATA0, EMAD0, GPIO0	
18	CS	Host parallel chip select, host serial SPI chip select
19	SCDIO, SCDOUT, PSEL, GPIO9	Serial control port data input and output, parallel port type select
20	INTREQ, ABOOT	Control port interrupt request, automatic boot enable
21	EXTMEM, GPIO8	External memory chip select or general purpose input & output number 8
22	SDATAN1	PCM audio data input number one
23	VD3	Digital positive supply
24	DGND3	Digital supply ground
25	SCLKN1, STCCLK2	PCM audio input bit clock
26	LRCLKN1	PCM audio input sample rate clock
27	CMPDAT, SDATAN2	PCM audio data input number two
28	CMPCLK, SCLKN2	PCM audio input bit clock
29	CMPREQ, LRCLKN2	PCM audio input sample rate clock
30	CLKIN	Master clock input
31	CLKSEL	DSP clock select
32	FILT2	Phase locked loop filter
33	FILT1	Phase locked loop filter
34	VA	Analog positive supply
35	AGND	Analog supply ground
36	RESET	Master reset input
37	DD	Reserved
38	DC	Reserved
39	AUDATA2	Digital audio output 2
40	AUDATA1	Digital audio output 1
41	AUDATA0	Digital audio output 0
42	LRCLK	Audio output sample rate clock
43	SCLK	Audio output bit clock
44	MCLK	Audio master clock

LC89055W (IC810)

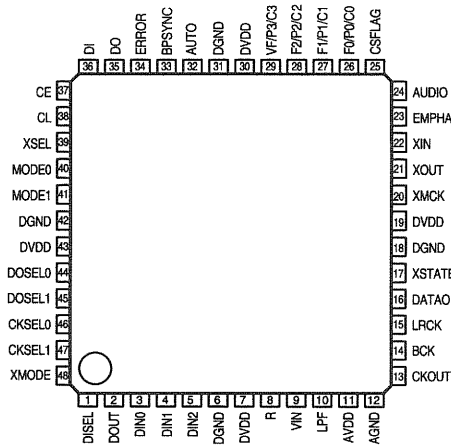

LC89055W Terminal Function

Pin No.	Pin Name	I/O	Function
1	DISEL	I	Data input terminal (select input pin of DIN0, DIN1)
2	DOUT	O	Input bi-phase data through output terminal
3	DIN0	I	Amp built-in coaxial/optical input correspond data input terminal
4	DIN1	I	Amp built-in coaxial/optical input correspond data input terminal
5	DIN2	I	Optical input correspond data input terminal
6	DGND		Digital GND
7	DVDD		Digital power supply
8	R	I	VCO gain control input terminal
9	VIN	I	VCO free-run frequency setting input terminal
10	LPF	O	PLL loop filter setting terminal
11	AVDD		Analog power supply
12	AGND		Analog GND
13	CKOUT	O	Clock output terminal (256fs, 384fs, 512fs, X'tal osc., VCO free-run osc.)
14	BCK	O	64fs clock output terminal
15	LRCK	O	fs clock output terminal (L: Rch, H: Lch, I ² S: Reverse)
16	DATAO	O	Data output terminal
17	XSTATE	O	Input data detecting result output terminal
18	DGND		Digital GND
19	DVDD		Digital power supply
20	XMCK	O	X'tal osc. clock output terminal (24.576MHz or 12.288MHz)
21	XOUT	O	X'tal osc. connection output terminal
22	XIN	I	X'tal osc. connection input terminal, external signal input possible (24.576MHz or 12.288MHz)
23	EMPHA	O	Emphasis information output terminal of channel status
24	AUDIO	O	Bit1 output terminal of channel status
25	CSFLAG	O	Top 40bit revise flag output terminal of channel status
26	F0/P0/C0	O	Input fs cal. sig. out/data type out/input word inf. output terminal
27	F1/P1/C1	O	Input fs cal. sig. out/data type out/input word inf. output terminal
28	F2/P2/C2	O	Input fs cal. sig. out/data type out/input word inf. output terminal
29	VF/P3/C3	O	Validity flag out/data type out/input word inf. output terminal
30	DVDD		Digital power supply
31	DGND		Digital GND
32	AUTO	O	Non PCM burst data transfer detect sig. output terminal
33	BPSYNC	O	Non PCM burst data preamble Pa, Pb, Pc, Pd sync sig. output terminal
34	ERROR	O	PLL lock error, data error flag output terminal
35	DO	O	CPU/IFD read data output terminal
36	DI	I	CPU I/F write data input terminal
37	CE	I	CPU I/F chip enable input terminal
38	CL	I	CPU I/F chip enable input terminal
39	XSEL	I	Frequency select input pin of XIN X'tal osc. (24.576MHz or 12.288MHz)
40	MODE0	I	Mode setting input terminal
41	MODE1	I	Mode setting input terminal
42	DGND		Digital GND
43	DVDD		Digital power supply
44	DOSEL0	I	Data output format select input terminal
45	DOSEL1	I	Data output format select input terminal
46	CKSEL0	I	Output clock select input terminal
47	CKSEL1	I	Output clock select input terminal
48	XMODE	I	Reset input terminal

• For latch-up countermeasure, set digital (DVDD) and analog (AVDD) power on/off in the same timing.

AK4527VQ (IC813)

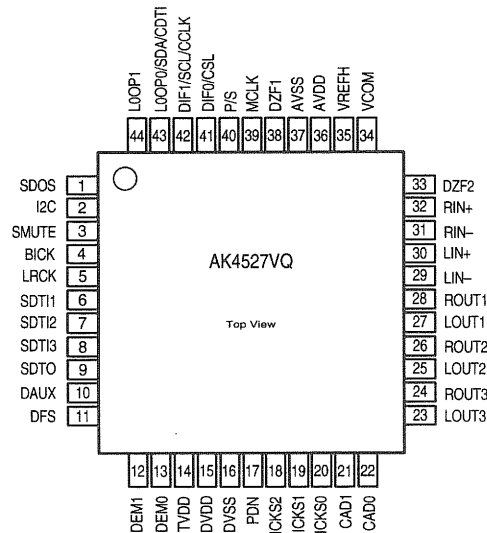

AK4527VQ Terminal Function

Pin No.	Pin Name	I/O	Function
1	SDOS	I	SDTO source select pin, L: Internal ADC output, H: DAUX input
2	I2C	I	Serial control mode select pin, L: 3-core serial, H: I ² C bus
3	SMUTE	I	Soft mute pin, H: Soft mute start, L: Release
4	BICK	I	Audio serial data clock pin
5	LRCK	I	Input channel clock pin
6	SDTI1	I	DAC1 audio serial data input pin
7	SDTI2	I	DAC2 audio serial data input pin
8	SDTI3	I	DAC3 audio serial data input pin
9	SDTO	O	Audio serial data output pin
10	DAUX	I	Auxiliary audio serial data input pin
11	DFS	I	Double speed sampling mode pin, L: Normal, H: Double
12	DEM1	I	De-emphasis-1 pin
13	DEM0	I	De-emphasis-2 pin
14	TVDD	—	Power pin for output buffer, 2.7V~5.5V
15	DVDD	—	Digital power pin, 4.5V~5.5V
16	DVSS	—	Digital GND pin, 0V
17	PDN	I	Power down & reset pin, L: Powered-down and register initialized, Reset with PDN when switching CAD0-1
18	ICKS2	I	Input clock select-2 pin
19	ICKS1	I	Input clock select-1 pin
20	ICKS0	I	Input clock select-0 pin
21	CAD1	I	Chip address-1 pin
22	CAD0	I	Chip address-0 pin
23	LOUT3	O	DAC3L channel analog out pin
24	ROUT3	O	DAC3R channel analog out pin
25	LOUT2	O	DAC2L channel analog out pin
26	ROUT2	O	DAC2R channel analog out pin
27	LOUT1	O	DAC1L channel analog out pin
28	ROUT1	O	DAC1R channel analog out pin
29	LIN-	I	L-ch analog inverted input pin
30	LIN+	I	L-ch analog non-inverted input pin
31	RIN-	I	R-ch analog inverted input pin
32	RIN+	I	R-ch analog non-inverted input pin
33	DZF2	O	0 input detect 2 pin, H: Input data of G2 is 8192 times "0" in a raw or RSTN bit "0", L: When P/S= "0"
34	VCOM	O	Common V-out pin, AVDD/2, connect large capacitor to avoid noise
35	VREFH	I	Ref. V input pin, AVDD
36	AVDD	—	Analog GND pin, 4.5V~5.5V
37	AVSS	—	Analog GND pin, 0V
38	DZF1	O	0 input detect pin, H: Input data of G1 is 8192 times "0" in a raw or RSTN bit "0", L: When P/S= "0"
39	MCLK	I	Master clock input pin
40	P/S	I	Parallel/Serial select pin, L: Serial control
41	DIF0	I	Audio data I/F format 0 pin (parallel control)
41	CSN	I	Chip select pin (3-wire serial control), connect to DVDD when I ² C bus control
42	DIF1	I	Audio data I/F format 1 pin (parallel control)
42	SCL/CCLK	I	Control data clock pin (serial control), I ² C="L": CCLK (3-wire serial), I ² C="H": SCL (I ² C bus)
43	LOOP0	I	Loop back mode 0 pin (parallel control), effects digital loop back ADC to all DAC
43	SDA/CDTI	I/O	Control data input pin (serial control), I ² C="L": CCTI (3-wire serial), I2C="H" SDA (I ² C bus)
44	LOOP1	I	Loop back mode 1 pin, from SDT1 to all DAC

LC75721E (C301)

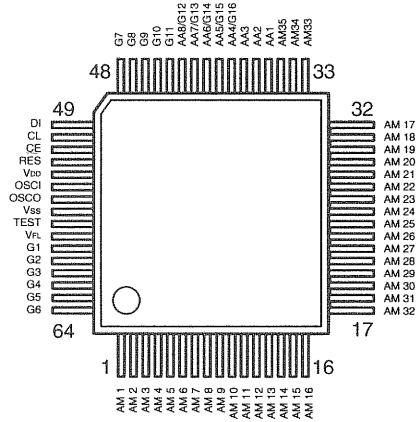

● LC75721E Terminal Function

Symbol	Function
VDD	Power terminal +5V
Vss	Power terminal GND
VFL	Power terminal FL drive
DI	Serial data transfer terminal DI: Data
CL	CL: Clock
CE	CE: Chip enable
OSCI	External CR connecting terminal
OSCO	
RES	System reset terminal
AM1~AM35	Anode output terminal
AA1~AA3	
AA4/G16	
AA5/G15	
AA6/G14	
AA7/G13	Anode/Grid output terminal
AA8/G12	
G1~G11	Grid output terminal
TEST	LSI test terminal

KIC9164AN(C221)

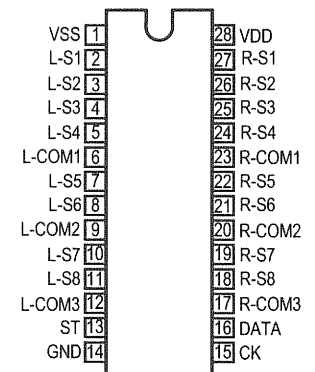

TC9273N-007(IC701)

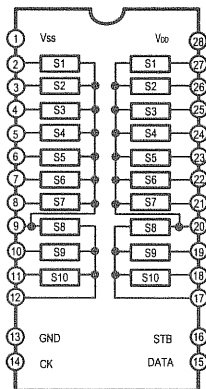

● TC9273N Terminal Function

Pin No	Symbol	Name	Function	
1	Vss	+Power Terminal	Dual Power Use:VDD = 8.0~17 V	Single Power Use:VDD = 8.0~18V GND=0V
13	GND	Digital Ground	GND=0V	
28	VDD	+Power Terminal	Vss=-8.0~-17V	
2~12	S1~S10	I/O Terminal	Input terminal of analog switch.	
14	CK	Clock Input	Clock input for data transfer.	Low level Border Input Terminal
15	DATA	Data Input	Serial input for switch setting.	
16	STB	Strobe Input	Strobe InputStrobe input for data writing.	

W27C020(IC807)

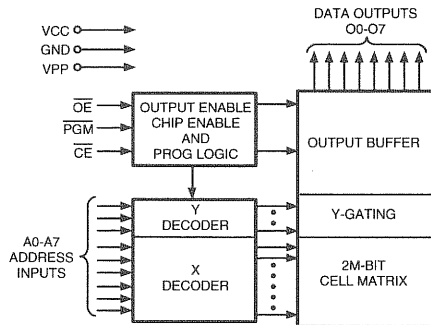
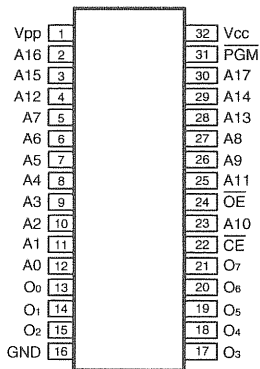

NJM2068DD
(IC241,251,261,271,281,291,702,703)
BA4510F(IC805~806)
NJM2068MD (IC814~816)

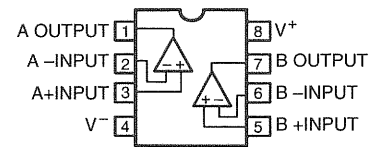

SN74LV00APW(IC822)

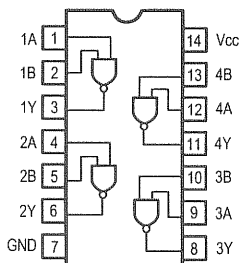

MC74HCU04AD(IC803)

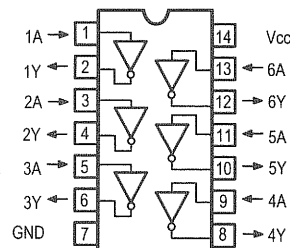

LA7952(IC601,651,652)

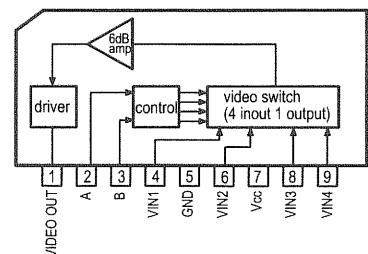

SN74LV4040 (IC831)

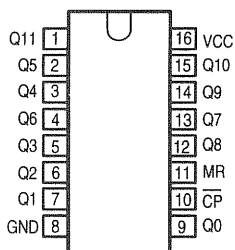

Terminal Function

INPUTS		OUTPUTS
CP	MR	Qn
↑	L	no change
↓	L	count
X	H	L

H=HIGH voltage level
L=LOW voltage level
X=don't care
↑=LOW-to-HIGH clock transition
↓=HIGH-to-LOW clock transition

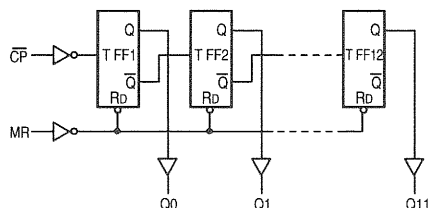

**KA7805 (IC103,104)
KA7815 (IC101)
KIA7812 (IC602)**

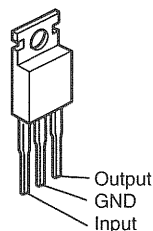

**NJM7805FA (S)
(IC829)**

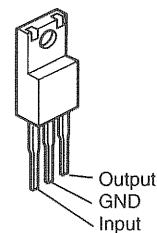

KIA7915 (IC102)

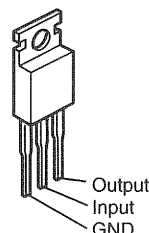

BA033FP (IC811)

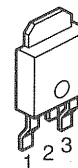

M62446FP (IC231)

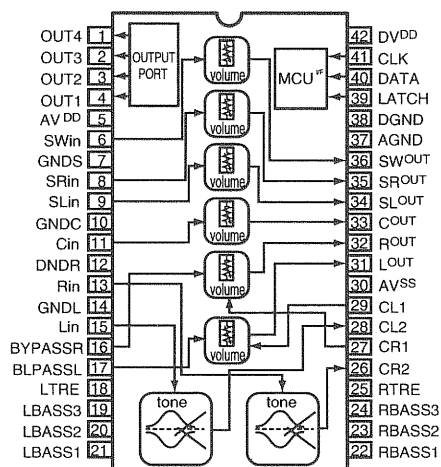

PC74HC4094 (IC302)

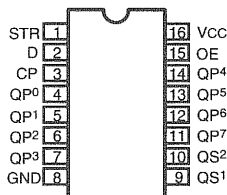

TC74HC125D (IC821)

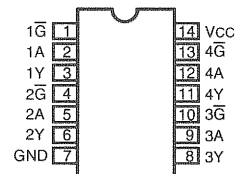

PC74HCT574 (IC808,809)

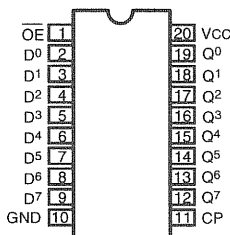

TC74HCT244 (IC828,830)

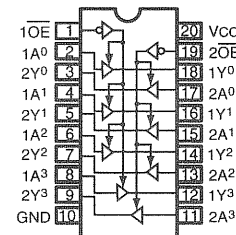

● **IC PROTECTOR**

ICP-N15 (IC105)

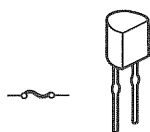

● **POSISTOR**

P43T7D330BW16



● **OPTICAL OUT**

GP1F37R1 (IC802)

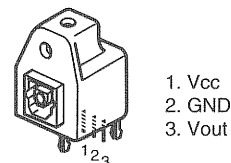

● **IR SENSOR**

NJL64H380A(RMC301)

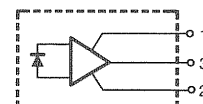
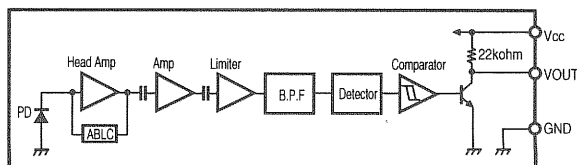
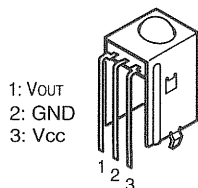

● TRANSISTOR

KTC2874 (B)
2SC3199(Y)
KSC1845 (F)
KTA1266 (Y)
KTA1268 (BL)
KTC3198(Y)
KTC3200 (BL)
KSA992 (F)

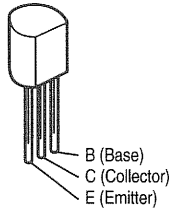

2SB1559
2SD2389

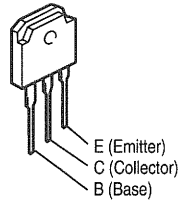

2SC4137

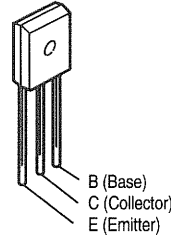

KSA916(Y)

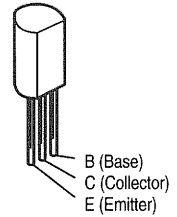

2SC2412K(S)

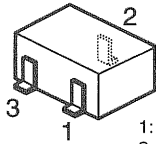

1: GND/(Emitter)
2: Output/(Collector)
3: Input/(Base)

DTA114ES(PNP)
DTA144ES(PNP)
DTC144ES(NPN)
DTC114YS(NPN)

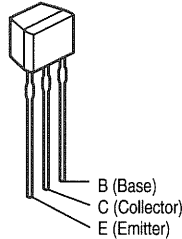

PNP Type

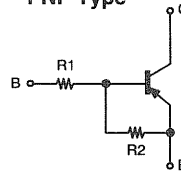

	R1	R2
DTA114ES	10kohm	10kohm
DTA144ES	47kohm	47kohm

NPN Type

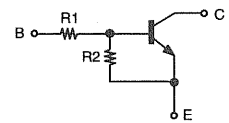

	R1	R2
DTC114YS	10kohm	47kohm
DTC144ES	47kohm	47kohm

2SC1740S

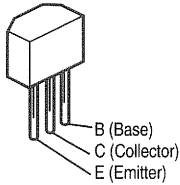

DTA114EK
DTA144EK
DTC114EK
DTC144EK

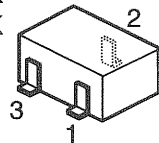

1: GND/(Emitter)
2: Output/(Collector)
3: Input/(Base)

PNP Type

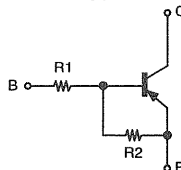

	R1	R2
DTA114EK	10kohm	10kohm
DTA144EK	47kohm	47kohm

NPN Type

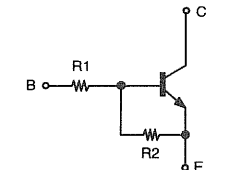

	R1	R2
DTC114EK	10kohm	10kohm
DTC144EK	47kohm	47kohm

● DIODES (LED Included)

1SS133

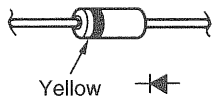

1N4004A

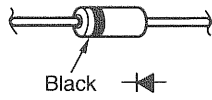

MTZJ9.1B
MTZJ5.6B
MTZJ6.2B
MTZJ18B
MTZJ20B
MTZJ3.3B
MTZJ7.5A
MTZJ7.5B

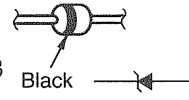

KDS160

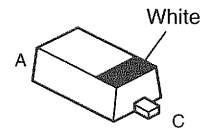

KBPC604

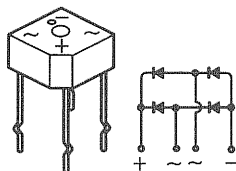

HL50RDRF4T
(LED301~307)

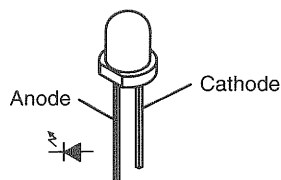

HL-30RDRF3
(LED308,309)

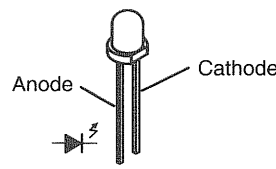

● FET

2SK117(Y)

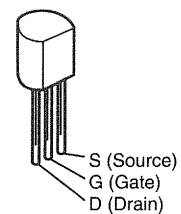

● FL DISPLAY

16-st-42GNK (FL301)

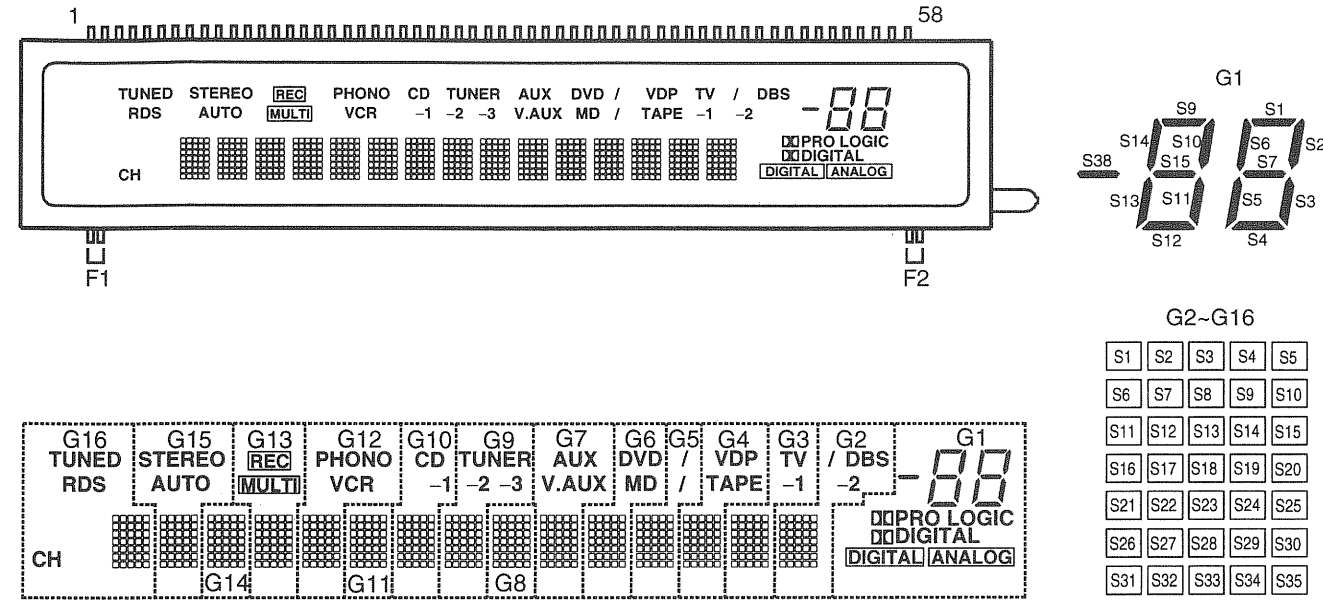

Pin Assignment

PIN NO.	1	2	3	4	5	6	7	8	9	10	11	12	13	14	15	16	17	18	19	20
CONNECTION	F1	F1	S1	S2	S3	S4	S5	S6	S7	S8	S9	S10	S11	S12	S13	S14	S15	S16	S17	S18
PIN NO.	21	22	23	24	25	26	27	28	29	30	31	32	33	34	35	36	37	38	39	40
CONNECTION	S19	S20	S21	S22	S23	S24	S25	S26	S27	S28	S29	S30	S31	S32	S33	S34	S35	S36	S37	S38
PIN NO.	41	42	43	44	45	46	47	48	49	50	51	52	53	54	55	56	57	58		
CONNECTION	G16	G15	G14	G13	G12	G11	G10	G9	G8	G7	G6	G5	G4	G3	G2	G1	F2	F2		

F1,F2 : Filament
 G1~G16 : Grid
 S1~S38 : Anode

Anode & Grid Assignment

	G1	G2-G16		G1	G2-G16		G1	G2-G16		G1	G2-G16
S1	S1	S1	S10	S10	S10	S19	---	S19	S28	---	S28
S2	S2	S2	S11	S11	S11	S20	---	S20	S29	---	S29
S3	S3	S3	S12	S12	S12	S21	---	S21	S30	---	S30
S4	S4	S4	S13	S13	S13	S22	---	S22	S31	---	S31
S5	S5	S5	S14	S14	S14	S23	---	S23	S32	---	S32
S6	S6	S6	S15	S15	S15	S24	---	S24	S33	---	S33
S7	S7	S7	S16	---	S16	S25	---	S25	S34	---	S34
S8	---	S8	S17	DIGITAL	S17	S26	---	S26	S35	---	S35
S9	S9	S9	S18	PRO LOGIC	S18	S27	---	S27			

	G1	G2	G3	G4	G5	G6	G7	G8	G9	G10	G11	G12	G13	G14	G15	G16
S36	DIGITAL	/	TV	VDP	/(DVD)	DVD	AUX	---	TUNER	CD	---	PHONO	REC	---	STEREO	TUNED
S37	ANALOG	-2	-1	TAPE	/(MD)	MD	V.MAX	---	-2	-1	---	VCR	MULTI	---	AUTO	RDS
S38	S38	DBS	---	---	---	---	---	---	-3	---	---	---	---	---	---	CH

PRINTED WIRING BAORDS

1 2 3 4 5 6 7 8

MAIN P.W.B. ASS'Y

A

B

C

D

E

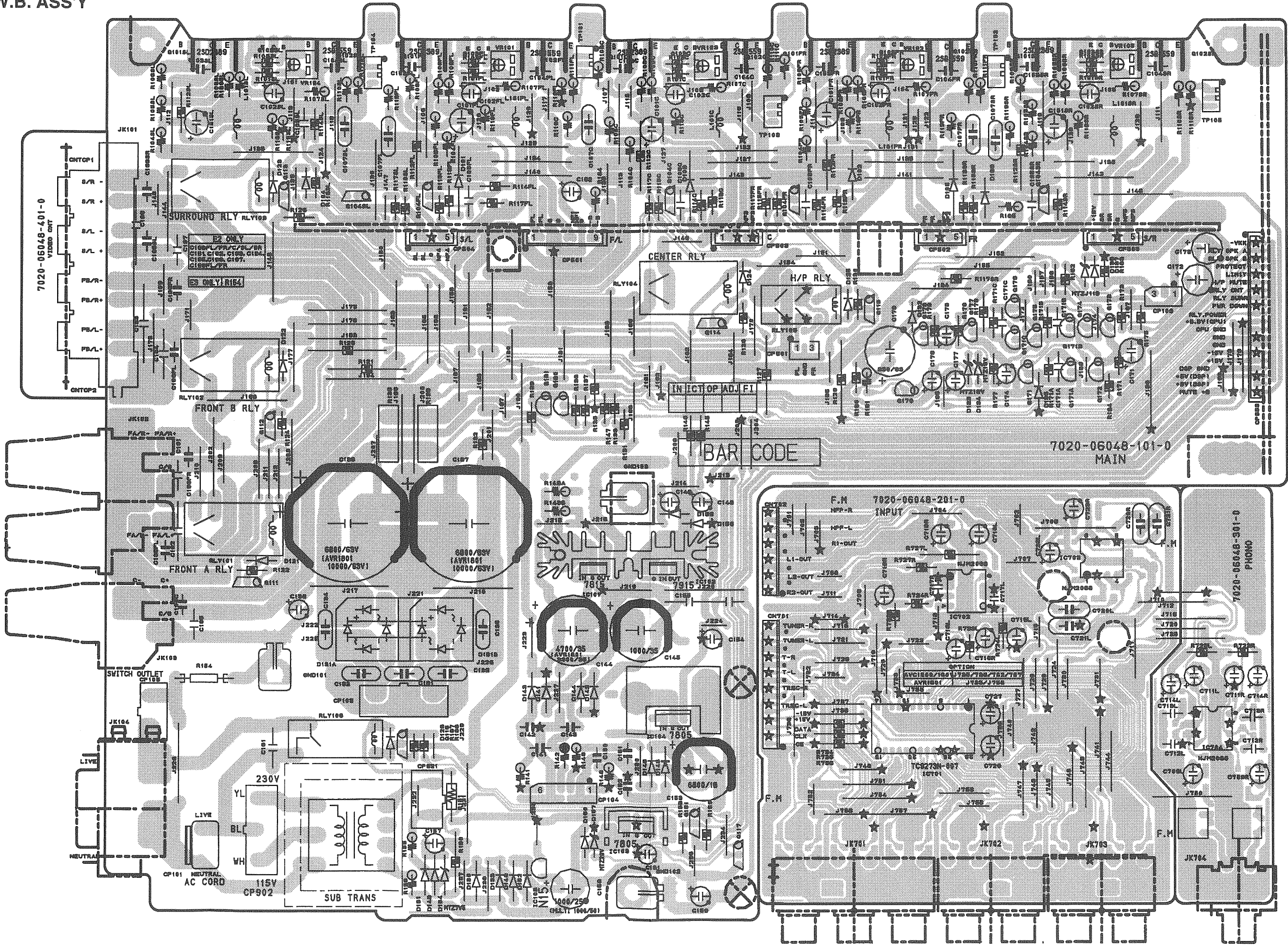

COMPONENT SIDE

1 2 3 4 5 6 7 8

A

B

C

D

E

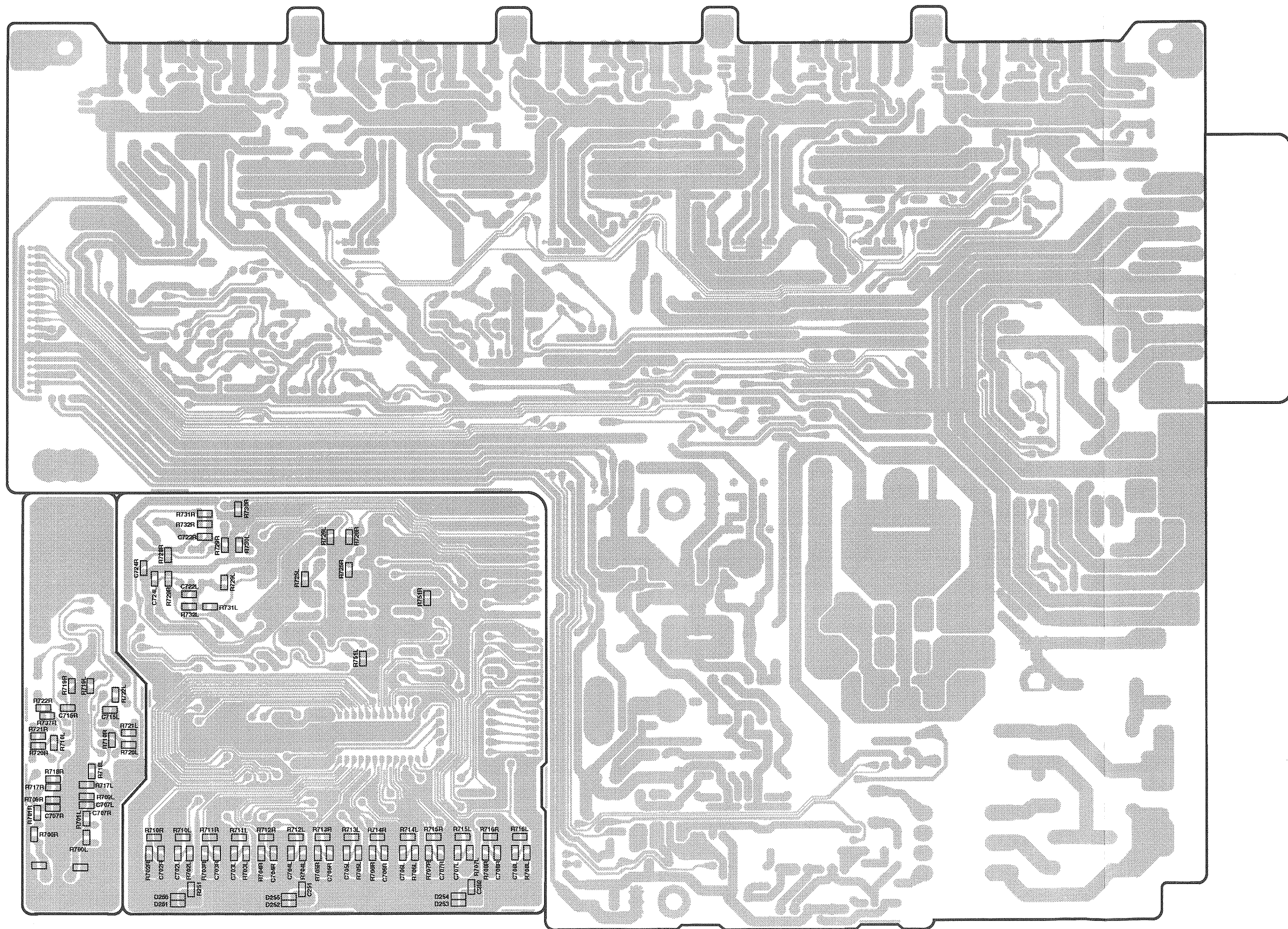

FOIL SIDE

1 2 3 4 5 6 7 8

PROCESSOR P.W.B. ASS'Y

A

B

C

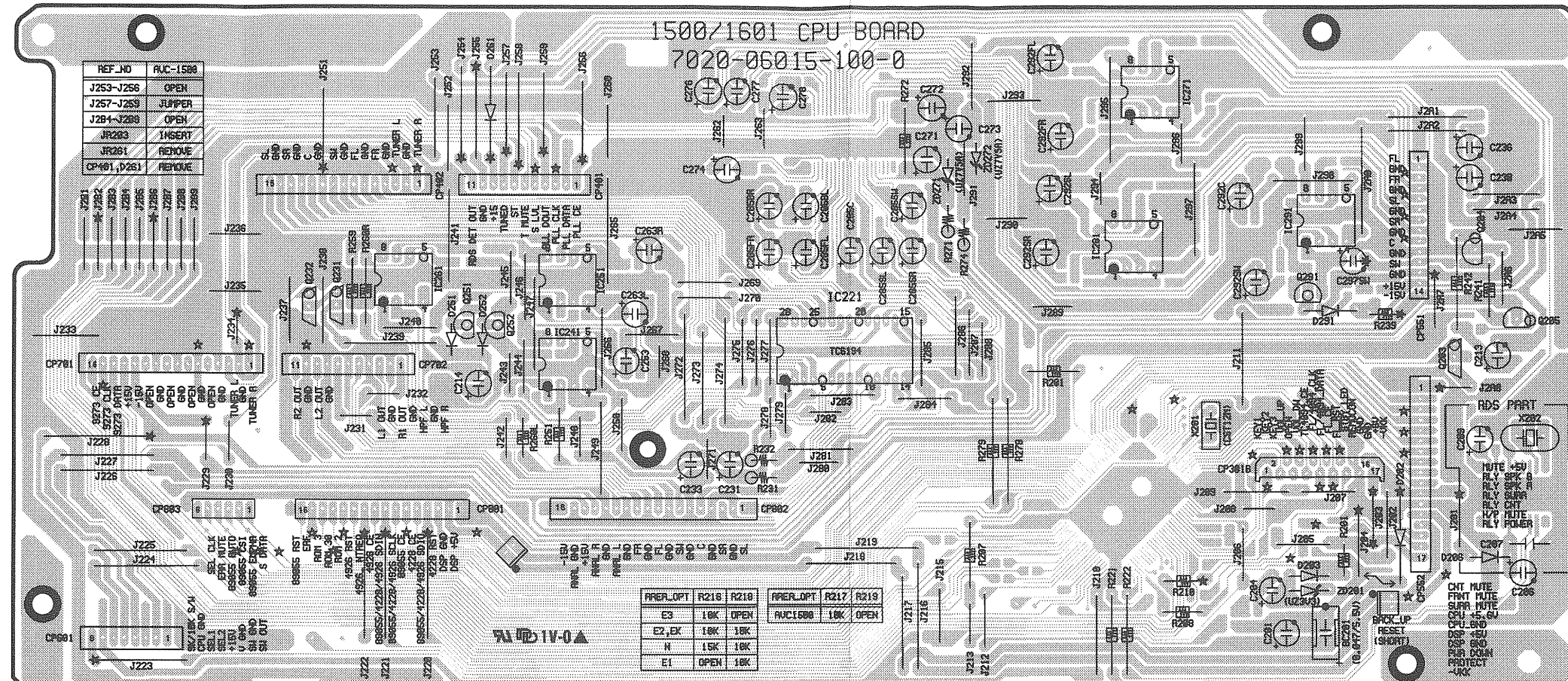

D

E

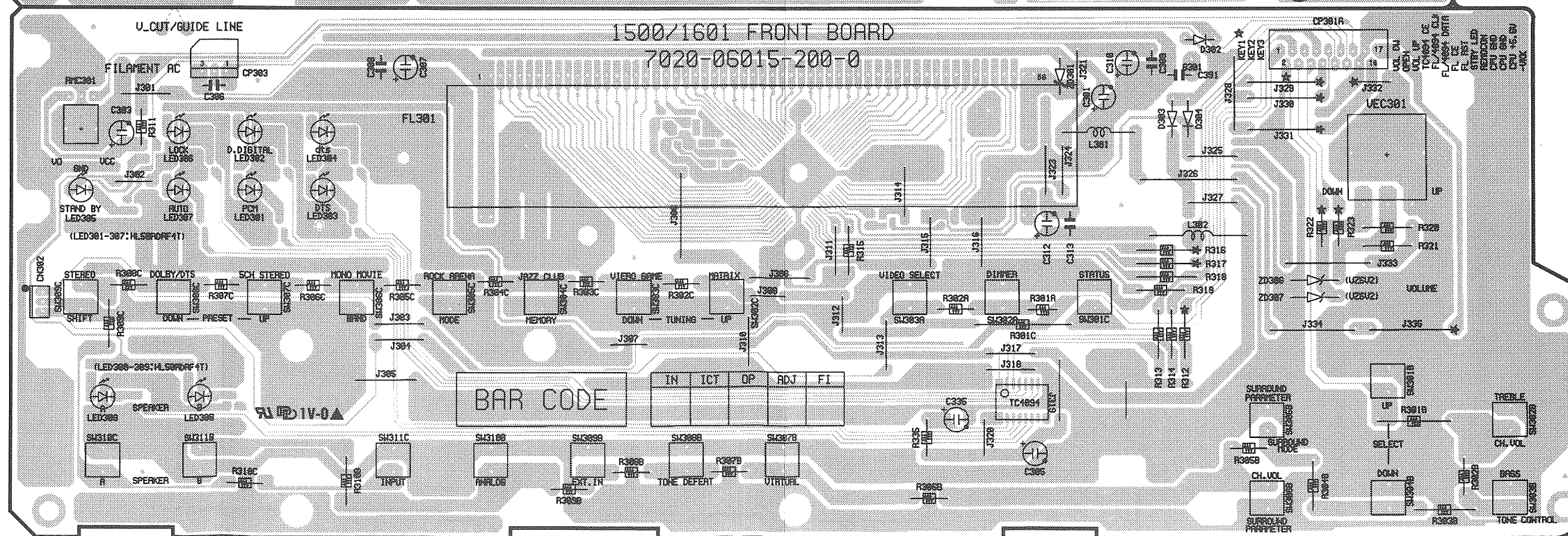

COMPONENT SIDE

1 2 3 4 5 6 7 8

A

B

C

D

E

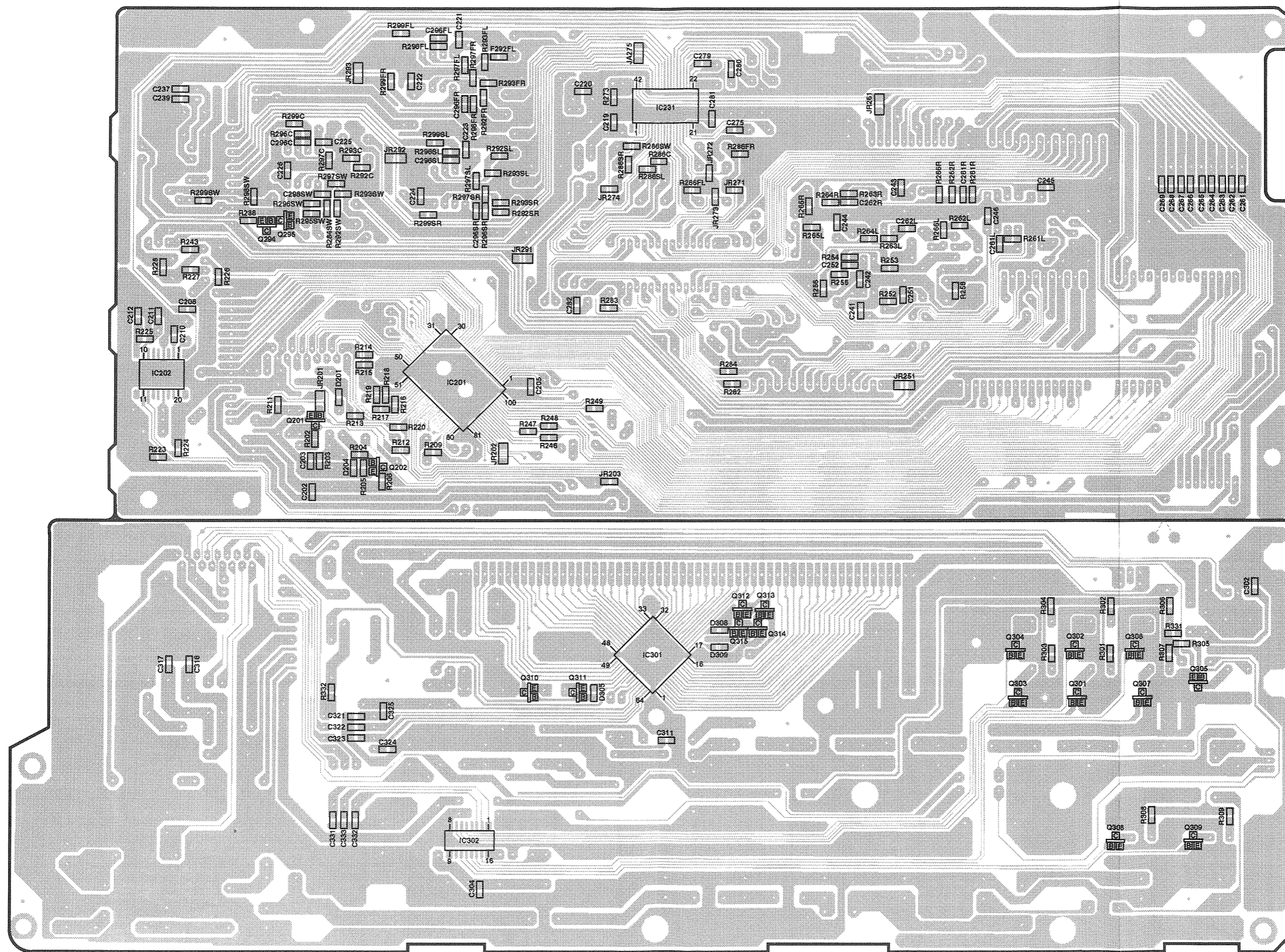

FOIL SIDE

1 2 3 4 5 6 7 8

CNT P.W.B. ASS'Y

A

B

C

D

E

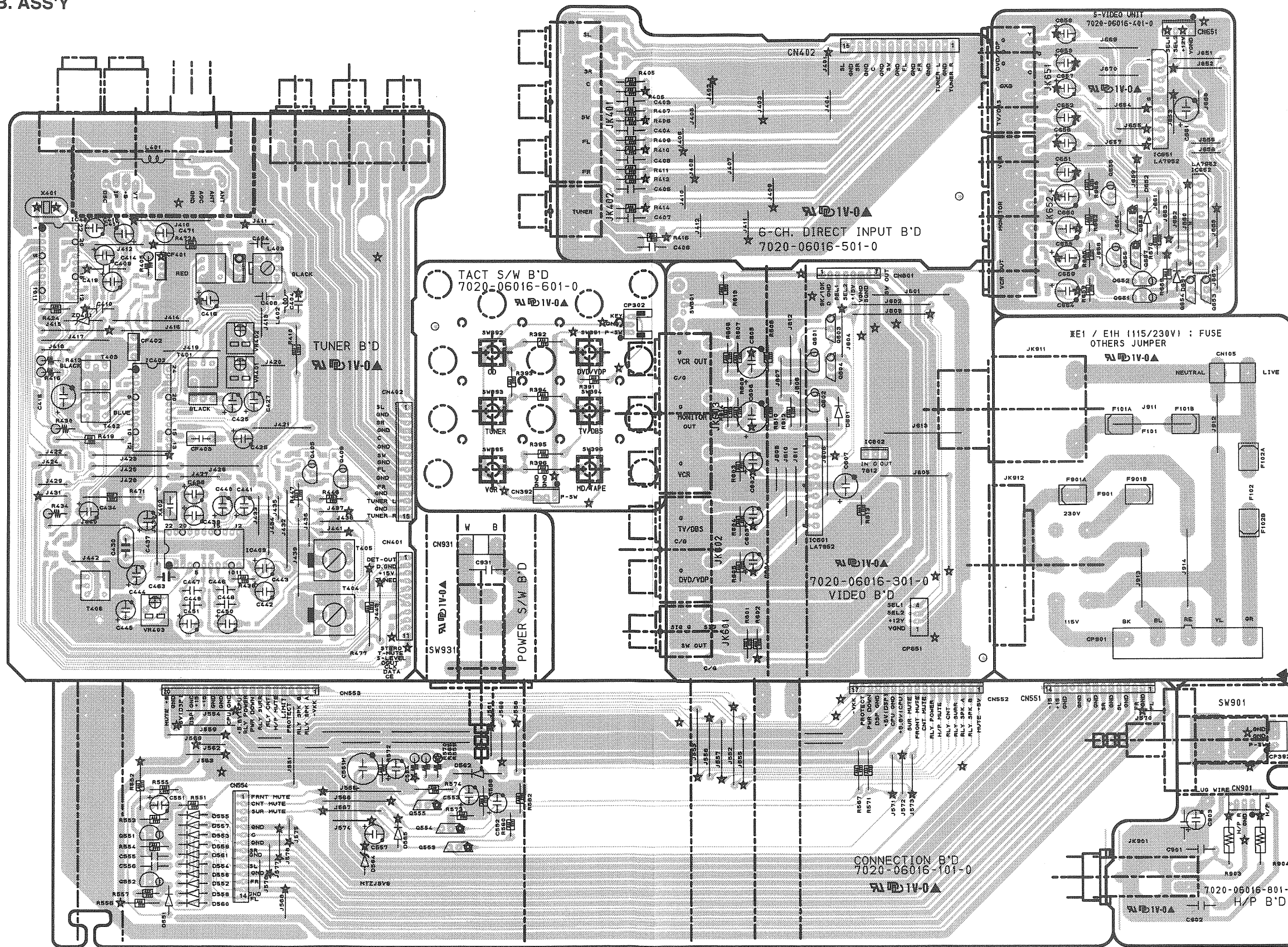

COMPONENT SIDE

1 2 3 4 5 6 7 8

A
B
C
D
E

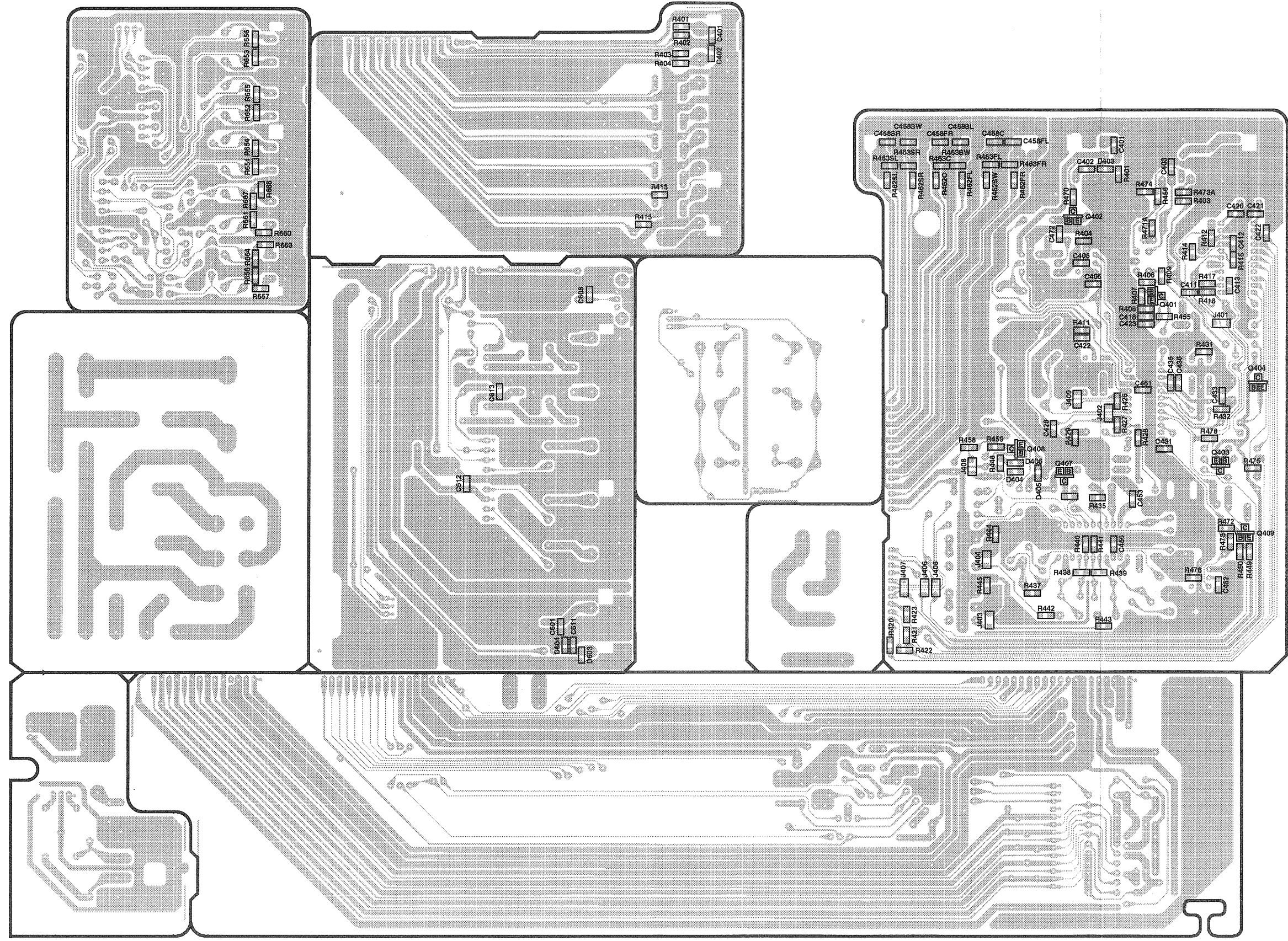

FOIL SIDE

1 2 3 4 5 6 7 8

PRE-AMP P.W.B. ASS'Y

A

B

C

D

E

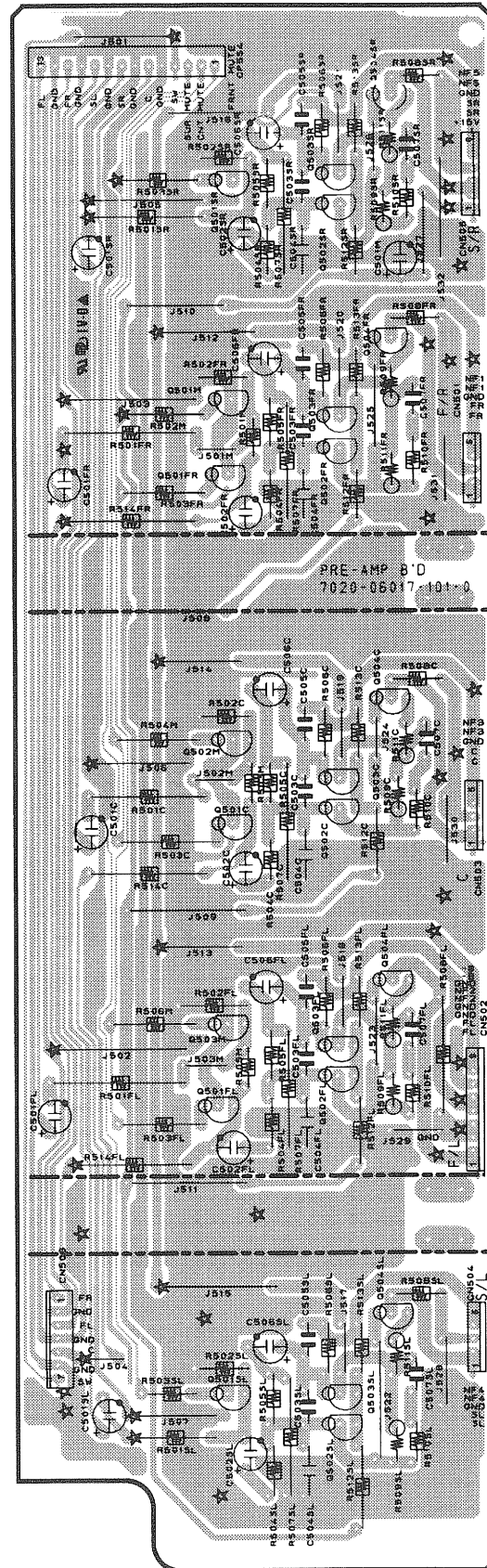

COMPONENT SIDE

DSP P.W.B. ASS'Y

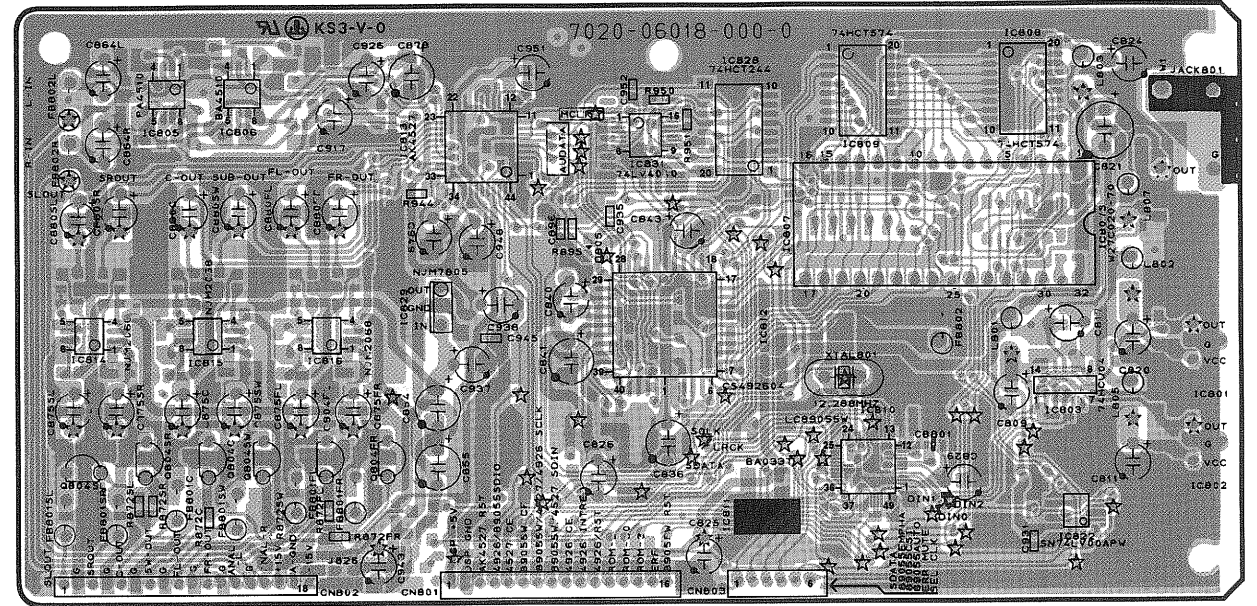

COMPONENT SIDE

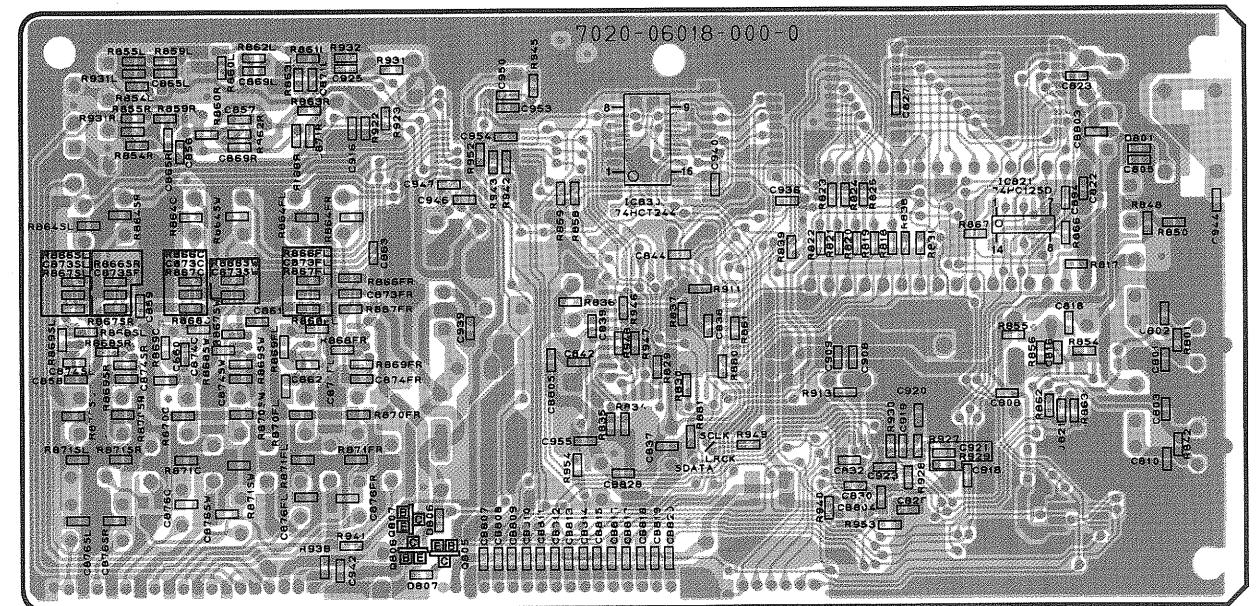

FOIL SIDE

Ref. No.	Part No.	Part Name	Remarks	Ref. No.	Part No.	Part Name	Remarks	
C443		Electrolytic 10 μ F/35V	D040100085100	C656-658		Electrolytic 47 μ F/10V	D040470082050	
C444		Electrolytic 4.7 μ F/50V	D0404R7087100				for E3,EU,E1,E1C, E1H,E1T	
C445		Electrolytic 10 μ F/35V	D040100085100	C659,660		Electrolytic 470 μ F/10V	D040471082060	
C446,447		Ceramic 270pF/50V	D004271277050				for E3,EU,E1,E1C, E1H,E1T	
C446,447		Ceramic 330pF/50V	D000331167070	C661		Electrolytic 100 μ F/16V	D040101083100	
C446,447		Ceramic 180pF/50V	D000181067060				for E3,EU,E1,E1C, E1H,E1T	
C448,449		Ceramic 470pF/50V	D004471067060	C662,663		Ceramic chip 0.047 μ F/50V	D011473777200	
C448,449		Ceramic 330pF/50V	D000331167070				for E3,EU,E1,E1C, E1H,E1T	
C450,451		Electrolytic 10 μ F/35V	D040100085100	C901,902		Ceramic 0.001 μ F/50V	D005102177530	
C453		Ceramic chip 27pF/50V	D010270167200	C903		Electrolytic 1 μ F/50V	D040010087080	
C456		Ceramic chip 680pF/50V	D010681167200	C904	960 9003 108	Ceramic 0.022 μ F/25V	D005223594520	
C461		Ceramic chip 27pF/50V	D010270167200	OTHER PARTS GROUP				Q'ty
C462		Ceramic chip 470pF/50V	D010471167200	CF401	960 0187 104	Ceramic filter SFE10.7MA8	E430107000140	1
C462C,FL, FR,SL,SR, SW		Ceramic chip 220pF/50V	D010221167200	CF401	960 0177 509	Ceramic filter SFE10.7MS3GH	E430107000150	1
C463		Mylar film 0.056 μ F/100V	D02056306C060	CF401	960 0187 104	Ceramic filter SFE10.7MA8	E430107000140	1
C464		Ceramic 3pF/50V	D000030007050	CF402	960 0187 104	Ceramic filter SFE10.7MA8	E430107000140	1
C471VT		Electrolytic 1 μ F/50V	D040010087080	CF402	960 0177 509	Ceramic filter SFE10.7MS3GH	E430107000150	1
C472VT		Ceramic chip 0.047 μ F/50V	D011473777200	CF402	960 0177 509	Ceramic filter SFE10.7MS3GH	E430107000150	1
C551		Electrolytic 2.2 μ F/50V	D0402R2087100	CF403	960 0187 609	Ceramic resonator	E830450000070	1
C551M		Electrolytic 100 μ F/35V	D040101085100	CN392	960 0198 009	2P connector cord	L000800020040	1
C551S		Ceramic 0.047 μ F/50V	D005473597520	CN401	963 0046 600	11P connector base	L101352371110	1
C552-554		Electrolytic 0.1 μ F/50V	D040R10087070	CN402	963 0049 607	15P connector base	L101352371510	1
C555,556		Ceramic 0.01 μ F/16V	D005103773530	CN551	960 0124 604	14P connector base	L101352371410	1
C557		Electrolytic 10 μ F/35V	D040100085050	CN552	963 0049 704	17P connector base	L101352371710	1
C601		Ceramic chip 100pF/50V	D010101167200	CN553	963 0049 801	20P connector base	L101352372010	1
C602-604		Electrolytic 47 μ F/10V	D040470082050	CN554	960 0198 106	14P connector cord	L000800140010	1
C605,606		Electrolytic 470 μ F/6.3V	D040471081100	CN601	963 0046 309	8P connector base	L101352370810	1
C607		Electrolytic 100 μ F/16V	D040101083100	CN651	960 0197 903	4P connector cord	L000141040010	1
C608		Ceramic chip 100pF/50V	D010101167200	CN901	960 0197 301	3P connector cord	L352103263300	1
C608		Carbon chip 0 ohm 1/10W	C200000060200	CP302	963 0049 908	3P connector base	L101220030010	1
C611		Ceramic chip 0.01 μ F/50V	D011103777200	CP392	963 0048 909	3P connector base	L101220030000	1
C612,613		Ceramic chip 0.047 μ F/50V	D011473777200				for E3,EU	
C651-653		Electrolytic 47 μ F/10V	D040470082050				for E3,EU,E1, E1C,E1H,E1T	
C654,655		Electrolytic 470 μ F/10V	D040471082060				for E3,EU,E1,E1C, E1H,E1T	

Ref. No.	Part No.	Part Name	Remarks	Q'ty	Ref. No.	Part No.	Part Name	Remarks	Q'ty
CP392	960 0059 707	2P connector base	L000351020040 for E2,E1,E1C, E1H,E1T	1		960 0181 401	4P S terminal	G403040010010 for E3,EU,E1, E1C,E1H,E1T	1
CP651	963 0050 104	4P connector base	L101220040000 for E3,EU,E1, E1C,E1H,E1T	1	—	960 0176 209	Push switch	G000122000010 for E3,EU	1
FE401	960 0187 706	Front end	E900401010020	1	—	960 0187 502	Head phone jack(D6.5)	G402038400031	1
G901	—	1P wire	8410800010010	1					
J403,404		Carbon chip 0 ohm 1/10W	C200000061300 for E3,EU,E1, E1C,E1H,E1T	2					
L401	963 0052 102	Inductor 1μH	D3301R0001020	1					
L402	960 0010 307	Inductor 10μH	D330100700520	1					
L403	963 0056 409	MW IF COIL RBW07VB-K5025 BLK	D950500500010	1					
SW391-396	963 0045 708	Tact switch	G180000270010	6					
SW601	963 0056 700	SLIDE SW	G060110100010 for E1,E1H,E1T	1					
SW901	963 0056 603	Push switch	G000040890000 for E2,E1,E1C, E1H,E1T	1					
SW901	960 0176 209	Push switch	G000122000010 for E3,EU	1					
T401	960 0186 600	MW IF COIL PCFMAF-270	D950500200000	1					
T402	960 0007 349	FM DET TRANS	D951561100000	1					
T403	960 0007 352	FM DET TRANS	D951561200000	1					
T404,405	960 0071 207	MPX filter	E401500100000 for E2	2					
T406	960 0037 607	antibirdie filter	E403126832410 for E2	1					
X401	960 0187 405	Crystal 7.2 MHz	E8007R2000071	1					
X402	963 0043 302	Resonator CSB456F11	E830456000050	1					
—	960 0184 000	Screw bracket	4010210196000	2					
—	963 0054 003	Shield tuner pack	3070210056000	1					
—	960 0184 602	Plaate	4470210146000	1					
—	963 0052 403	3P antenna terminal	G593021068010	1					
—	960 0188 307	6P pin jack	G603060610010	1					
—	960 0194 508	1P pin jack	G600010003020	1					
—	960 0194 605	2P pin jack	G601020163010	1					
—	960 0188 404	3P pin jack	G606030164020	1					
—	960 0181 304	3P S terminal	G402042190000 for E3,EU,E1, E1C,E1H,E1T	1					

AMP P.W.B. UNIT

DSP P.W.B. UNIT

Ref. No.	Part No.	Part Name	Remarks	
SEMICONDUCTORS GROUP				
Q501C,FL, FR,SL,SR	960 0196 603	Transistor KTC2874B	J502287400010	
Q502C,FL, FR,SL,SR	960 0196 205	Transistor KSA992F	J5000992F0050	
Q503C,FL, FR,SL,SR	960 0196 506	Transistor KSC1845F	J5021845F0000	
RESISTORS GROUP				
R509C,FL, FR,SL,SR	960 9005 902	Metal film 1.2 kohm 1/4W	C060012263050	
R511C,FL, FR,SL,SR	960 9004 301	Metal film 47 ohm 1/4W	C060047063050	
CAPACITORS GROUP				
C501C,FL, FR,SL,SR		Electrolytic 22 μ F/16V	D040220083070	
C501M		Electrolytic 10 μ F/35V	D040100085100	
C502C,FL, FR,SL,SR		Electrolytic 10 μ F/35V	D040100085100	
C503C,FL, FR,SL,SR	963 9003 165	Ceramic 220pF/500V	D009092212500	
C504C,FL, FR,SL,SR	963 9003 178	Ceramic 220pF/50V	D005221277520	
C505C,FL, FR,SL,SR	963 9003 181	Ceramic 33pF/500V	D00033006D050	
C506C,FL, FR,SL,SR		Electrolytic 100 μ F/10V	D040101082060	
C507C,FL, FR,SL,SR	963 9003 194	Mylar film 0.0022 μ F/100V	D02022206C060	
OTHER PARTS GROUP			Q'ty	
CN501	963 0046 406	9P connector socket	L101352370910	1
CN502-504	963 0050 201	5P connector socket	L101352370510	3
CN505	963 0050 308	6P connector socket	L101352370610	1
CP554	963 0050 405	14P connector base	L101220140000	1
—	960 0184 000	Screw bracket	4010210196000	2

Ref. No.	Part No.	Part Name	Remarks
SEMICONDUCTORS GROUP			
IC802	960 0180 800	Optical connector (GP1F37R1)	E100137000010
IC803	963 0023 500	IC MC74HCU04AD	J040740400200
IC805,806	963 0043 807	IC BA4510F	J121451000010
IC807	960 0195 002	IC W27C020	J000270200010
IC807S	963 0025 508	32P IC socket	G450320000010
IC808,809	960 0179 206	IC DC74HCT574	J040745740040
IC810	960 0195 507	IC LC89055W	J046890550010
IC811	960 0195 905	IC BA033FP	J12603R300020
IC812	960 0195 701	IC CS492604-CL	262 2657 907
IC813	960 0195 604	IC AK4527VQ	J080452700010
IC814~816	960 0174 502	IC NJM2068DD	J121206800020
IC821	960 0195 206	IC TC74HC125D	J040741250130
IC822	960 0195 109	IC SN74LV00APW	J040740000170
IC828	963 0043 409	IC DC74HCT244	J040742440080
IC829	960 0196 001	IC NJM7805FA (S)	J126780500130
IC830	963 0043 409	IC DC74HCT244	J040742440080
IC831	960 0195 303	IC SN74LV4040	J040744040030
Q804C,FL, FR,SL,SR, SW	960 0196 603	Transistor KTC2874B	J502287400010
Q805	269 0083 901	Transistor DTA114EK	J5200114E0210
Q806	269 0082 902	Transistor DTC114EK	J5220114E0210
Q807	269 0083 901	Transistor DTA114EK	J5200114E0210
D801	960 0197 000	Diode KDS160	K005016000010
D803-807	960 0197 000	Diode KDS160	K005016000010
RESISTORS GROUP			
J821,824		Carbon chip 0 ohm 1/10W	C200000060200
J828,829		Carbon chip 0 ohm 1/10W	C200000060200
R817-825		Carbon chip 10 kohm 1/10W	C200010360200
R830,831		Carbon chip 10 kohm 1/10W	C200010360200
R834,835		Carbon chip 4.7 kohm 1/10W	C200047260200
R836		Carbon chip 10 kohm 1/10W	C200010360200
R837		Carbon chip 47 ohm 1/10W	C200047060200
R838		Carbon chip 10 kohm 1/10W	C200010360200
R839,842		Carbon chip 4.7 kohm 1/10W	C200047260200
R848		Carbon chip 100 ohm 1/10W	C200010160200
R850		Carbon chip 75 ohm 1/10W	C200075060200
R854		Carbon chip 2.2 kohm 1/10W	C200022260200
R854L,4R		Carbon chip 47 kohm 1/10W	C200047360200
R855		Carbon chip 100 kohm 1/10W	C200010460200
R856		Carbon chip 10 kohm 1/10W	C200010360200
R858,859		Carbon chip 0 ohm 1/10W	C200000060200
R859R		Carbon chip 4.7 kohm 1/10W	C200047260200
R860L,R		Carbon chip 4.7 kohm 1/10W	C200047260200
R861		Carbon chip 47 ohm 1/10W	C200047060200
R861L,R		Carbon chip 470 ohm 1/10W	C200047160200
R862L,R		Carbon chip 4.7 kohm 1/10W	C200047260200

Ref. No.	Part No.	Part Name	Remarks	Ref. No.	Part No.	Part Name	Remarks
R863L,R		Carbon chip 470 ohm 1/10W	C200047160200	CAPACITORS GROUP			
R864C,FL, FR,SL,SR, SW		Carbon chip 100 kohm 1/10W	C200010460200	C803,805		Ceramic chip 22pF/50V	D010220167200
R866		Carbon chip 10 kohm 1/10W	C200010360200	C808		Ceramic chip 0.1µF/50V	D011104597200
R866C,FL, FR,SL,SR, SW		Carbon chip 4.7 kohm 1/10W	C200047260200	C809		Electrolytic 100µF/10V	D040101082060
R867		Carbon chip 100 kohm 1/10W	C200010460200	C810		Ceramic chip 0.1µF/50V	D011104597200
R867C,FL, FR,SL,SR, SW		Carbon chip 4.7 kohm 1/10W	C200047260200	C811		Electrolytic 47µF/10V	D040470082050
R868C,FL, FR,SL,SR, SW		Carbon chip 4.7 kohm 1/10W	C200047260200	C816		Ceramic chip 22pF/50V	D010220167200
R869C,FL, FR,L,SL,SR, SW		Carbon chip 4.7 kohm 1/10W	C200047260200	C817		Electrolytic 0.1µF/50V	D040R10087070
R870C,FL, FR,SL,SR, SW		Carbon chip 1 kohm 1/10W	C200010260200	C818		Ceramic chip 0.1µF/50V	D011104597200
R871C,FL, FR,SL,SR, SW		Carbon chip 100 kohm 1/10W	C200010460200	C821		Electrolytic 1000µF/6.3V	D040102081060
R872C,FL, FR,SL,SR, SW		Carbon chip 2.2 kohm 1/10W	C200022260200	C822,823		Ceramic chip 0.1µF/50V	D011104597200
R880,881		Carbon chip 47 ohm 1/10W	C200047060200	C824		Electrolytic 100µF/10V	D040101082060
R895		Carbon chip 100 kohm 1/10W	C200010460200	C825		Electrolytic 1µF/50V	D040010087050
R911		Carbon chip 10 kohm 1/10W	C200010360200	C826		Electrolytic 10µF/35V	D040100085050
R913		Carbon chip 1 Mohm 1/10W	C200010560200	C827		Ceramic chip 0.1µF/50V	D011104597200
R922		Carbon chip 4.7 kohm 1/10W	C200047260200	C829		Electrolytic 10µF/35V	D040100085050
R923		Carbon chip 6.2 kohm 1/10W	C200062260200	C830		Ceramic chip 0.1µF/50V	D011104597200
R927		Carbon chip 75 ohm 1/10W	C200075060200	C832,833		Ceramic chip 0.1µF/50V	D011104597200
R928		Carbon chip 5.1 kohm 1/10W	C200051260200	C836		Electrolytic 220µF/6.3V	D040221081050
R929		Carbon chip 8.2 kohm 1/10W	C200082260200	C837,838		Ceramic chip 0.1µF/50V	D011104597200
R930		Carbon chip 3 kohm 1/10W	C200030260200	C839		Ceramic chip 0.22µF/50V	D011224597200
R931		Carbon chip 6.2 kohm 1/10W	C200062260200	C840		Electrolytic 2.2µF/50V	D0402R2087250
R931L,R		Carbon chip 18 kohm 1/10W	C200018360200	C841		Electrolytic 47µF/10V	D040470082050
R932		Carbon chip 4.7 kohm 1/10W	C200047260200	C842		Ceramic chip 0.1µF/50V	D011104597200
R938		Carbon chip 470 kohm 1/10W	C200047460200	C843		Electrolytic 100µF/10V	D040101082060
R940		Carbon chip 10 kohm 1/10W	C200010360200	C844		Ceramic chip 0.1µF/50V	D011104597200
R941		Carbon chip 1 kohm 1/10W	C200010260200	C854,855		Electrolytic 100µF/25V	D040101084060
R941		Carbon chip 470 ohm 1/10W	C200047160200	C856~863		Ceramic chip 0.1µF/50V	D011104597200
R942,943		Carbon chip 0 ohm 1/10W	C200000060200	C864L,R		Electrolytic 10µF/35V	D040100085050
R945~948		Carbon chip 0 ohm 1/10W	C200000060200	C865L,R		Ceramic chip 100pF/50V	D010101167200
R949		Carbon chip 47 ohm 1/10W	C200047060200	C869L,R		Ceramic chip 100pF/50V	D010101167200
R950,951		Carbon chip 0 ohm 1/10W	C200000060200	C871L,R		Ceramic chip 1000pF/50V	D011102777200
R952~954		Carbon chip 100 ohm 1/10W	C200010160200	C873C,FL, FR,SL,SR, SW		Ceramic chip 680pF/50V	D010681167200
				C874C,FL, FR,SL,SR, SW		Ceramic chip 680pF/50V	D010681167200
				C875C,FL, FR,SL,SR, SW		Electrolytic 10µF/35V	D040100085050
				C876C,FL, FR,SL,SR, SW		Ceramic chip 3300pF/50V	D011332777200
				C878		Electrolytic 100µF/10V	D040101082060
				C880C,FL, FR,SL,SR, SW		Electrolytic 10µF/35V	D040100085050
				C894,896		Ceramic chip 0.1µF/50V	D011104597200
				C908,909		Ceramic chip 27pF/50V	D010270167200
				C916		Ceramic chip 0.1µF/50V	D011104597200

VOLTAGE SEL P.W.B. UNIT

Ref. No.	Part No.	Part Name	Remarks	Ref. No.	Part No.	Part Name	Remarks	Q'ty
C917		Electrolytic 10μF/35V	D040100085050	OTHER PARTS GROUP				
C918		Ceramic chip 0.1μF/50V	D011104597200	CN105	963 0059 105	2P connector cord	L000121020040 for E1,E1H,E1T	1
C919		Ceramic chip 0.01μF/50V	D011103777200	CN903	963 0058 805	2P connector cord	L000101020070 for E1,E1H,E1T	1
C920		Ceramic chip 0.1μF/50V	D011104597200	CP901	963 0061 203	5P connector base	L104353280500 for E1,E1H,E1T	1
C921		Ceramic chip 0.01μF/50V	D011103777200	CP902	963 0059 309	3P connector base	L000151030030 for E1,E1H,E1T	1
C923,925		Ceramic chip 0.1μF/50V	D011104597200	△F101	960 0142 602	Fuse 2.5A	G650252251160 for E1,E1H,E1T	1
C926		Electrolytic 10μF/35V	D040100085050	△F101A,B	960 0005 804	Fuse clip	G645000050010 for E1,E1H,E1T	2
C931,935		Ceramic chip 0.01μF/50V	D011103777200	△F102	963 0044 709	Fuse 3.15A	G650312251160 for E1,E1H,E1T	1
C936		Ceramic chip 0.1μF/50V	D011104597200	△F102A,B	960 0005 804	Fuse clip	G645000050010 for E1,E1H,E1T	2
C937		Electrolytic 10μF/35V	D040100085050	△F901	963 0057 107	Fuse 6.3A	G650632251160 for E1,E1H,E1T	1
C938		Electrolytic 1μF/50V	D040010087050	△F901A,B	960 0005 804	Fuse clip	G645000050010 for E1,E1H,E1T	2
C939,940		Ceramic chip 0.01μF/50V	D011103777200	△JK911	960 0143 203	AC outlet(2P)	G435040110000 for E1,E1H,E1T	1
C943		Electrolytic 0.1μF/50V	D040R10087070	JK912	963 0056 904	SLIDE SW	G060268320010 for E1,E1H,E1T	1
C944		Ceramic chip 0.01μF/50V	D011103777200	—		Supporter	4070210192000 for E1,E1H,E1T	2
C945		Ceramic chip 1000pF/50V	D011102777200	—	963 0051 103	Spacer	4300210062000 for E1,E1H,E1T	1
C946,947		Ceramic chip 0.1μF/50V	D011104597200					
C948		Electrolytic 10μF/35V	D040100085050					
C949		Electrolytic 2.2μF/50V	D0402R2087250					
C950		Ceramic chip 0.1μF/50V	D011104597200					
C951		Electrolytic 100μF/10V	D040101082060					
C952,953		Ceramic chip 0.1μF/50V	D011104597200					
C956		Ceramic chip 1000pF/50V	D011102777200					
OTHER PARTS GROUP				OTHER PARTS GROUP				
CB801	963 0050 502	BEAD,COIL CHIPBEADS	7611010000020					1
CB803-805	963 0050 502	BEAD,COIL CHIPBEADS	7611010000020					3
CB807-820	963 0050 502	BEAD,COIL CHIPBEADS	7611010000020					14
CB828,840	963 0050 502	BEAD,COIL CHIPBEADS	7611010000020					2
CN801	963 0046 707	16P connector socket	L101352371610					1
CN802	963 0050 609	18P connector socket	L101352371810					1
CN803	963 0050 308	6P connector socket	L101352370610					1
FB801C,FL, FR,SL,SR, SW	963 0050 706	Beads inductor	7610035500010					6
FB802L,R	963 0050 706	Beads inductor	7610035500010					2
JACK801	963 0052 500	1P pin jack	G600010003100					1
L801	963 0050 803	Inductor 4.7μH	D3304R7000150					1
L803	963 0050 900	Inductor 2.2μH	D3302R2000150					1
L805	963 0050 803	Inductor 4.7μH	D3304R7000150					1
L807	963 0050 900	Inductor 2.2μH	D3302R2000150					1
XTAL801	960 0180 907	Crystal 12.288MHz	E80012R288020					1

EXPLODED VIEW

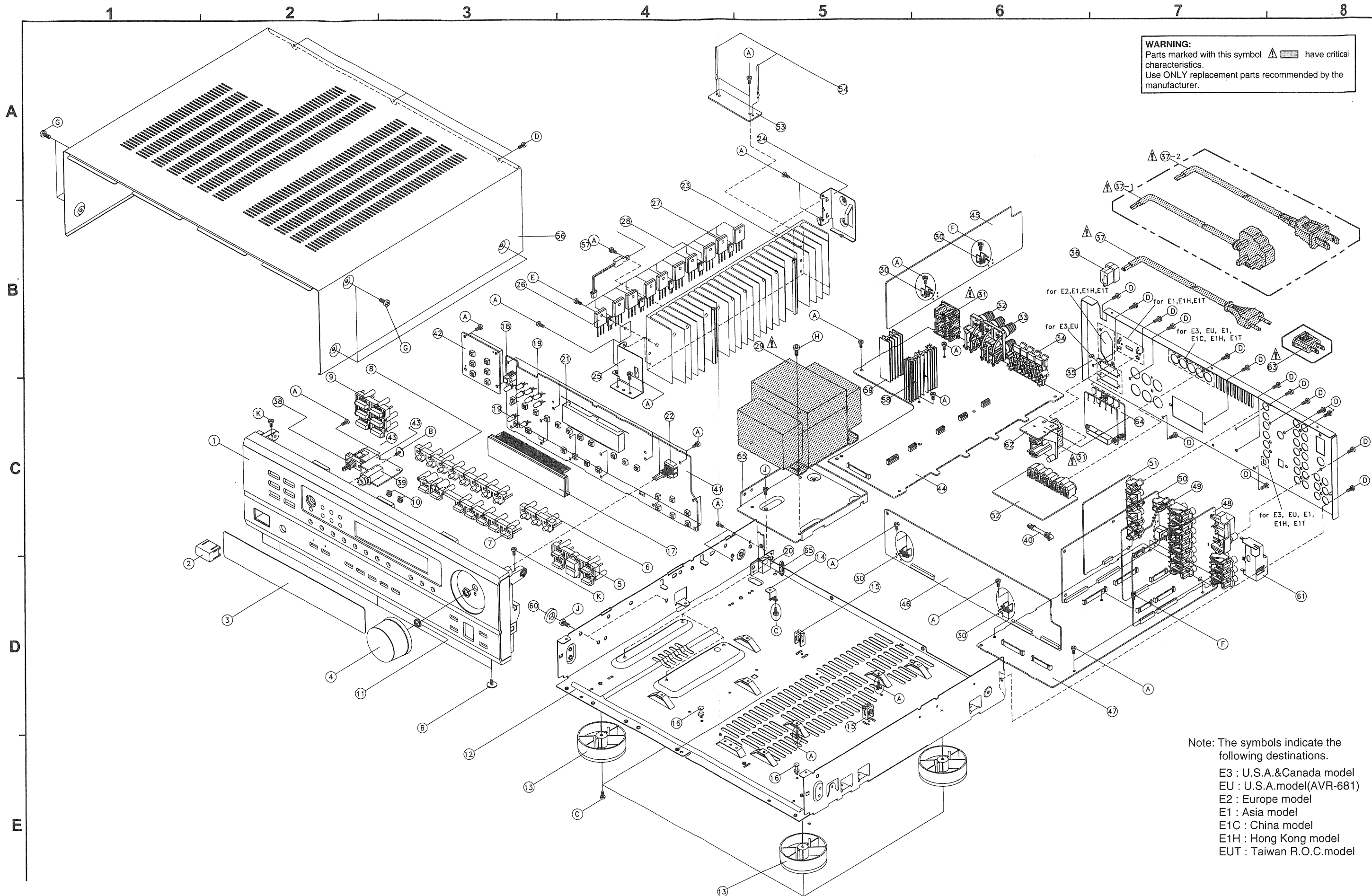

Note: The symbols indicate the following destinations.
 E3 : U.S.A.&Canada model
 EU : U.S.A.model(AVR-681)
 E2 : Europe model
 E1 : Asia model
 E1C : China model
 E1H : Hong Kong model
 EUT : Taiwan R.O.C.model

Note: The symbols in the column "Remarks" indicate the following destinations.
 E3: U.S.A. model, Csnada model E1C: China model
 EU: U.S.A. model (AVR-681) E1H: Hong Kong model
 E2: Europe model E1T: Taiwan R.O.C. model
 E1: Asia model

PARTS LIST OF EXPLODED VIEW

Ref. No.	Part No.	Part Name	Remarks	Q'ty	Ref. No.	Part No.	Part Name	Remarks	Q'ty
	963 0042 002	Main P.W.B assy	7025HK9908010 for E3,EU	1	1	963 0053 143	Front panel	3067210261020 for E1C(Black model)	1
	963 0042 028		7025HK9908040 for E2	1	2	960 0185 009	Power button	5090210201000 for Black model	1
	963 0042 031		7025HK9908110 for E1	1	2	960 0191 705	Power button	5097210201120 for Gold mode	1
	963 0042 044		7025HK9908100 for E1T	1	3	960 0191 501	Window	5077210262000	1
	963 0042 057		7025HK9908080 for E1H	1	4	963 0054 906	Main volume knob	5087210191010 for Black model	1
	963 0042 060		7025HK9908060 for E1C	1	4	960 0191 608	Main volume knob	5087210191100 for Gold mode	1
44	—	Main P.W.B assy		1	5	963 0053 703	Button (5key)	5097210471000 for Black model	1
49	—	Input P.W.B assy		1	5	960 0191 802	Button (5key)	5097210471100 for Gold mode	1
53	—	Video CNT P.W.B assy	for E3,EU,E1, E1C,E1H,E1T	1	6	963 0053 606	Button (3key)	5090210511000 for Black model	1
	963 0042 109	Processor P.W.B assy	7025HK9908011 for E3,EU	1	6	960 0192 209	Button (3key)	5097210511100 for Gold mode	1
	963 0042 112		7025HK9908041 for E2	1	7	963 0053 402	Button (7key)	5090210491000 for Black model	1
	963 0042 125		7025HK9908111 for E1,E1T,E1H,E1C	1	7	960 0192 005	Button (7key)	5097210491100 for Gold mode	1
41	—	Front P.W.B assy		1	8	963 0053 509	Button (8key)	5090210501000 for Black model	1
47	—	CPU P.W.B assy		1	8	960 0192 102	Button (8key)	5097210501100 for Gold mode	1
62	—	Outlet P.W.B assy	for E2	1	9	963 0053 305	Button (6key)	5090210481000 for Black model	1
	963 0042 206	CNT P.W.B assy	7025HK9908012 for E3,EU	1	9	960 0191 909	Button (6key)	5097210481100 for Gold mode	1
	963 0042 219		7025HK9908042 for E2	1	10	960 0191 404	Lens	3710210043000	2
	963 0042 222		7025HK9908112 for E1,E1T,E1H	1	11	963 0051 006	Knob spring	3720210116000	1
	963 0042 235		7025HK9908062 for E1C	1	12	960 0198 203	Chassis	3208210146300 for E3,EU,E2	1
42	—	Switch P.W.B assy		1	12	960 0198 216	Chassis	3208210146301 for E1,E1C,E1H,E1T	1
43	—	Head phone P.W.B assy		1	13	960 0183 904	Foot assy	4008020061010	4
46	—	Cnt P.W.B assy		1	14	960 0184 107	Supporter bracket	4010210206000	1
48	—	Tuner P.W.B assy		1	15	960 0003 301	PCB supporter	4070001601010	2
51	—	Video P.W.B assy		1	16	963 0051 103	Card spacer	4300210062000	2
52	—	S-Video P.W.B assy	for E3,EU,E1, E1C,E1H,E1T	1	17	960 0180 509	FLT (16-ST-42GNK)	K530164200010 FL301	1
45	—	Amp P.W.B assy	7025HK9908013	1	18	960 0181 100	IC NJL64H380A	E940643800000 RMC301	1
50	—	DSP P.W.B assy	7025HK9908014	1	19	960 0197 204	LED P15-RD/HL50DRF4T	K500052015010 LED301-309	9
64	—	Voltage sel P.W.B assy	for E1,E1T,E1H for E1,E1H,E1T	1	20	963 0044 505	Side bracket	4010210236000 for E2,E1,E1C,E1H,E1T	1
1	963 0053 101	Front panel	3067210261000 for E3	1	21	960 0184 408	FLT holder	4320200026000	1
1	963 0053 130	Front panel	3067210261030 for EU	1	22	960 0181 207	Rotary encoder	G121162420400 VEC301	1
1	963 0053 114	Front panel	3067210261010 for E2	1	23	—	Heat sink	2120210128200	1
1	963 0053 127	Front panel	3067210261120 for E1,E1C (Gold model),E1H,E1T	1	24	960 0184 204	Heat sink bracket B	4010210386000	1
					25	960 0184 301	Heat sink bracket F	4010210396000	1

Ref. No.	Part No.	Part Name	Remarks	Q'ty	Ref. No.	Part No.	Part Name	Remarks	Q'ty
26	960 0090 107	Transistor 2SB1559Y	J5011559Y1170 Q102C,FL,FR,SL,SR	5	55	960 0192 306	Trans bracket	4010210466000	1
27	960 0090 000	Transistor 2SD2389Y	J5032389Y1170 Q101C,FL,FR,SL,SR	5	56	963 0053 004	Top cover	3000210096000 for Black model	1
28	960 0114 300	Transistor 2SC4137	J5024137V0130 Q103C,FL,FR,SL,SR	5	56	960 0191 006	Top cover	3000210096100 for Gold mode	1
△	963 0053 907	Power trans	8200858690100 for E3,EU	1	57	960 0187 900	Posistor	F320161001020	1
△	963 0053 910	Power trans	8200858690090 for E2	1	58	—	Heat sink	2120043538050	1
△	963 0053 923	Power trans	8200858690080 for E1,E1H,E1T	1	59	—	Heat sink	2120044308010	1
△	963 0053 936	Power trans	8200858690110 for E1C	1	60	963 0051 200	Cushion	4050210165000	2
	30	960 0184 000	Screw bracket	4	61	963 0054 003	Shield tuner pack	3070210056000	1
△	31	960 0187 803	AC outlet(2P)	1	△	63	963 0061 300	AC plug adapter for E1T	1
△	31	960 0143 203	AC outlet	1	65	963 0044 602	Supporter	4070210192000 for E2,E1,E1C,E1H,E1T	1
	32	960 0194 809	2P speaker terminal	1	65	963 0044 602	Supporter	4070210192000 for E1,E1H,E1T	2
	33	960 0188 608	4P speaker terminal	1	★	960 0093 104	Push livet	2410040353010 for E2,E1,E1C,E1H,E1T	6
	34	960 0194 304	8P speaker terminal	1	★	963 0061 407	Fuse caution label	5527042410020 for E3,EU	1
	35	963 0053 208	Back panel	1	★	963 0061 407	FFC cable	L301186171850	1
	35	963 0053 240	Back panel	1	★	513 3340 001	Label (A)	for E1,E1H,E1T	1
	35	963 0053 211	Back panel	1	★	515 8030 066	Preset label	for E1,E1H,E1T	1
	35	963 0053 224	Back panel	1	★	513 2482 009	Caution label	for E1T	1
	35	963 0053 237	Back panel	1	★	513 2481 000	Serial No. sheet	for E1T	1
	36	960 0192 403	Cord bush	1	★	513 3331 007	Rating sheet	for E1,E1H,E1T	1
△	37	960 0165 304	AC cord assy	1	SCREWS				
△	37	963 0060 408	AC cord assy	1	A	9630018007	Screw (2S 3x8 ZNY/BH)	B020030081B10 for E3,EU	53
△	37-1	960 0143 009	AC cord assy	1	A	9630018007	Screw (2S 3x8 ZNY/BH)	B020030081B10 for E2,E1,E1C,E1H,E1T	55
△	37-2	960 0166 400	AC cord assy	1	B	960 9008 527	Screw (2S 3x8 WASHER)	1500001456020 for Black model	5
△	37-2	963 0060 301	AC cord assy	1	B	960 9008 420	Screw (2S 3x8 WASHER)	1500001456010 for Gold mode	5
	38	960 0176 209	Push switch	1	C	9630048200	Screw (2S 3x10 ZNY/BH)	B020030101B10	5
	38	963 0056 603	Push switch	1	D	9600108701	Screw (2S 3x10 DOT BK)	B020030103B11 for E3,EU	31
	39	960 0187 502	Head phone jack (D6.5)	1	D	9600108701	Screw (2S 3x10 DOT BK)	B020030103B11 for E2	28
	40	—	PCB holder	1	D	9600108701	Screw (2S 3x10 DOT BK)	B020030103B11 for E1,E1H,E1T	33
	54	—	Wire clamp	2	D	9600108701	Screw (2S 3x10 DOT BK)	B020030103B11 for E1C	30
					E	963 9004 009	Screw (2S 3x14 WASHER ZNY/HH)	B018230141H10	15
					F	9630018104	Screw (2S 3x17 ZNY/BH)	B020030171B10	2
					G	9630048307	Screw (2S 4x8 DOT BK)	1500040083B10 for Black model	6
					G	963 9004 012	Screw (2S 4x8 DOT NI)	1500040084B10 for Gold mode	6
					H	9609008417	Screw (3S 4x8 ZNY/BH)	B028940081B10	4
					J	963 9004 025	Screw (3S 4x6 ZNY/BH)	B020740061B10	6
					K	963 9004 038	Screw (2S 3x8 ZNY)	1500001206010	2

WIRING DIAGRAM

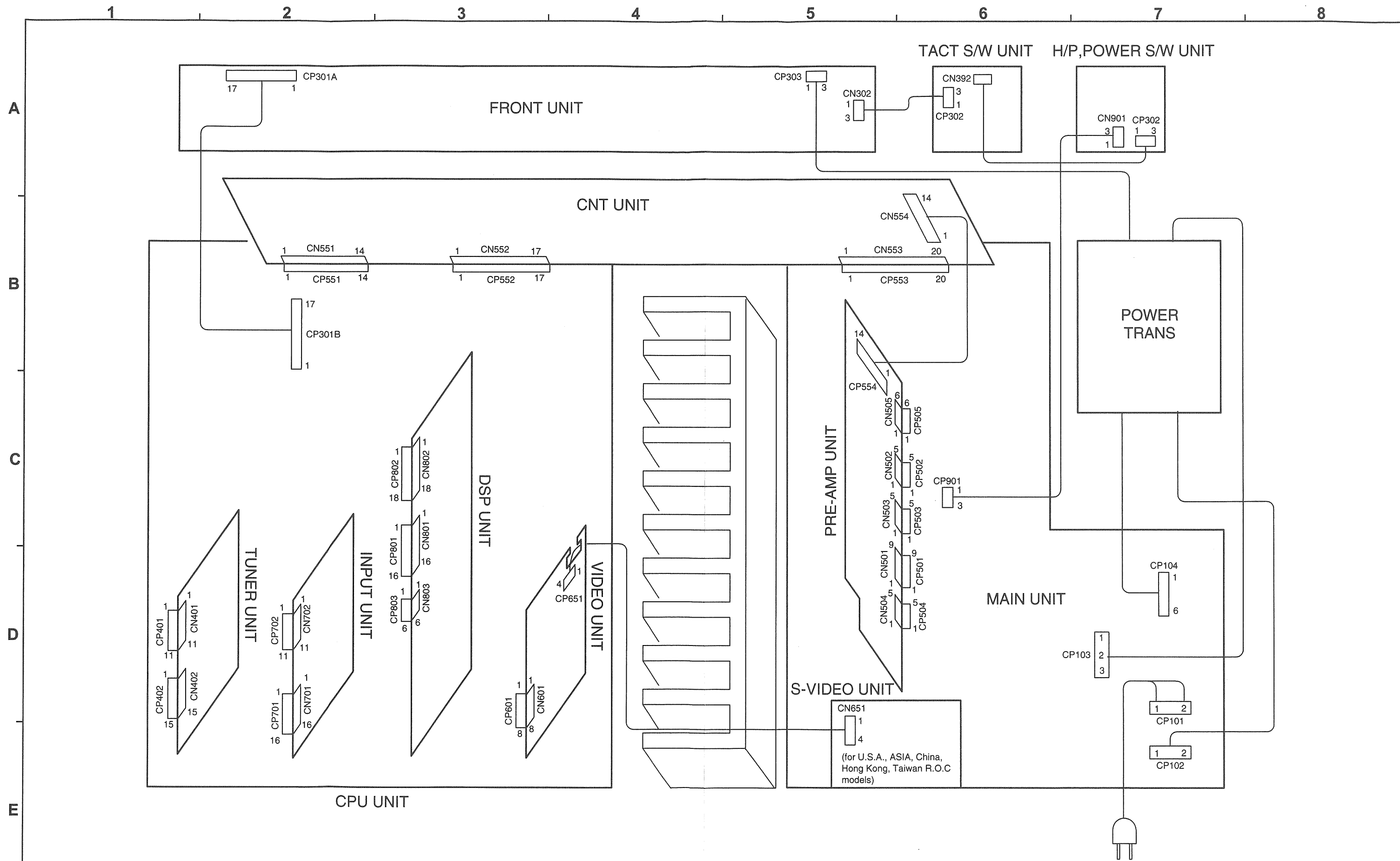

SCHEMATIC DIAGRAMS (1/8)

1 2 3 4 5 6 7 8

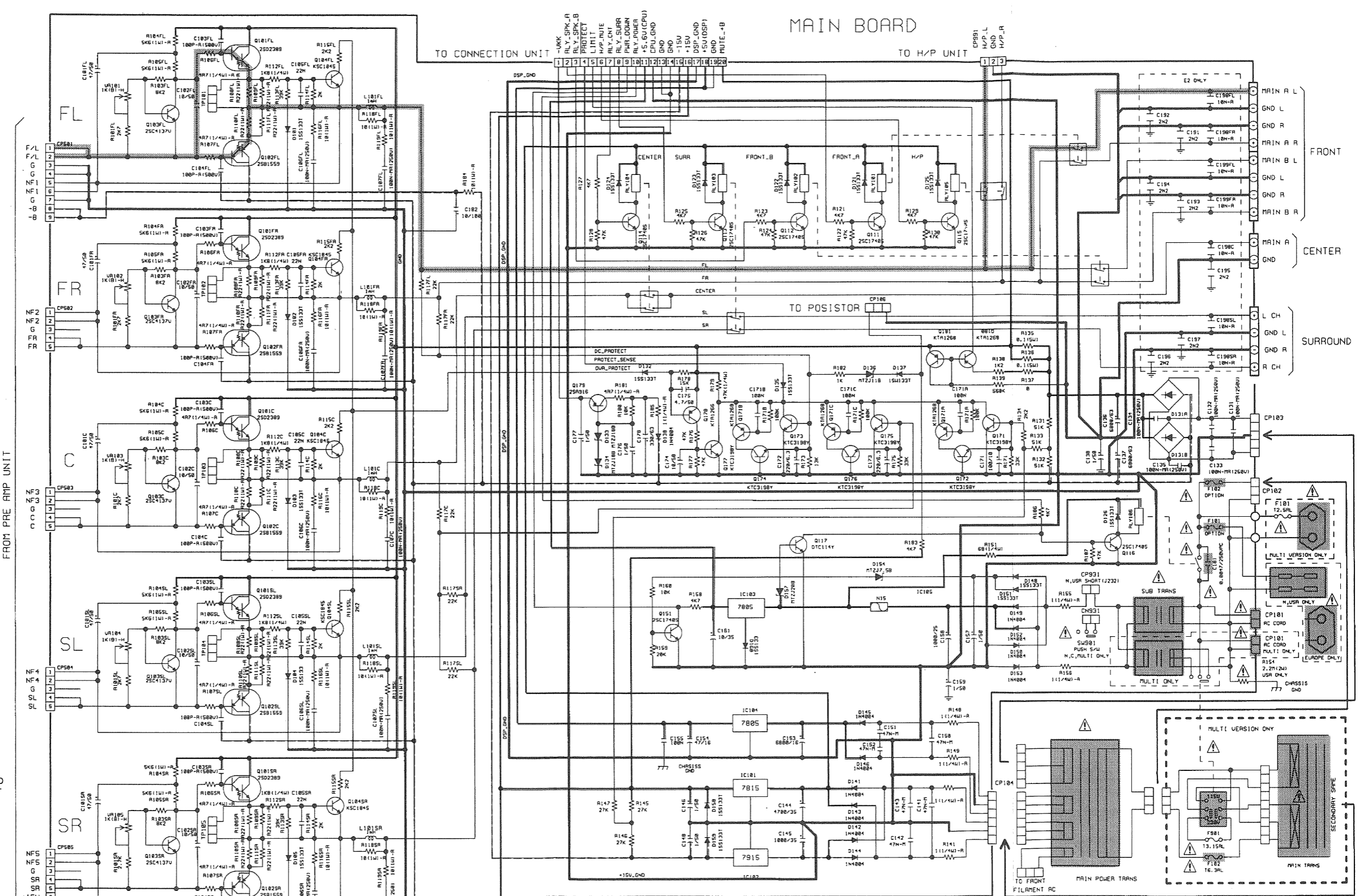

NOTICE
 ALL RESISTANCE VALUES IN OHM. K=1,000 OHM M=1,000,000 OHM
 ALL CAPACITANCE VALUES IN MICRO FARAD. P=MICRO-MICRO FARAD
 EACH VOLTAGE AND CURRENT ARE MEASURED AT NO SIGNAL INPUT
 CONDITION.
 CIRCUIT AND PARTS ARE SUBJECT TO CHANGE WITHOUT PRIOR
 NOTICE.

WARNING:
 Parts marked with this symbol have critical characteristics.
 Use ONLY replacement parts recommended by the manufacture.

CAUTION:
 Before returning the unit to the customer, make sure you make either (1) a
 leakage current check or (2) a line to chassis resistance check. If the leakage
 current exceeds 0.5 milliamperes, or if the resistance from chassis to either side
 of the power card is less than 460 kohms, the unit is defective.

WARNING:
 DO NOT return the unit to the customer until the problem is located and
 corrected.

— +B LINE
 - - - -B LINE
 ■■■■■ SIGNAL LINE

	F101	F102	F901	POSITION
N	T8A	T8A	X	MAIN B'D
E3	8A/125V	8A/125V	X	MAIN B'D
E2	T2.5AL	T3.15AL	X	MAIN B'D
C	X	T3.15AL	X	MAIN B'D
H,T,E1	T2.5AL	T6.3AL	T3.15AL	U.SEL B'D

SCHEMATIC DIAGRAMS (1/8)
 MAIN UNIT
 VOLTAGE SEL UNIT

SCHEMATIC DIAGRAMS (2/8)

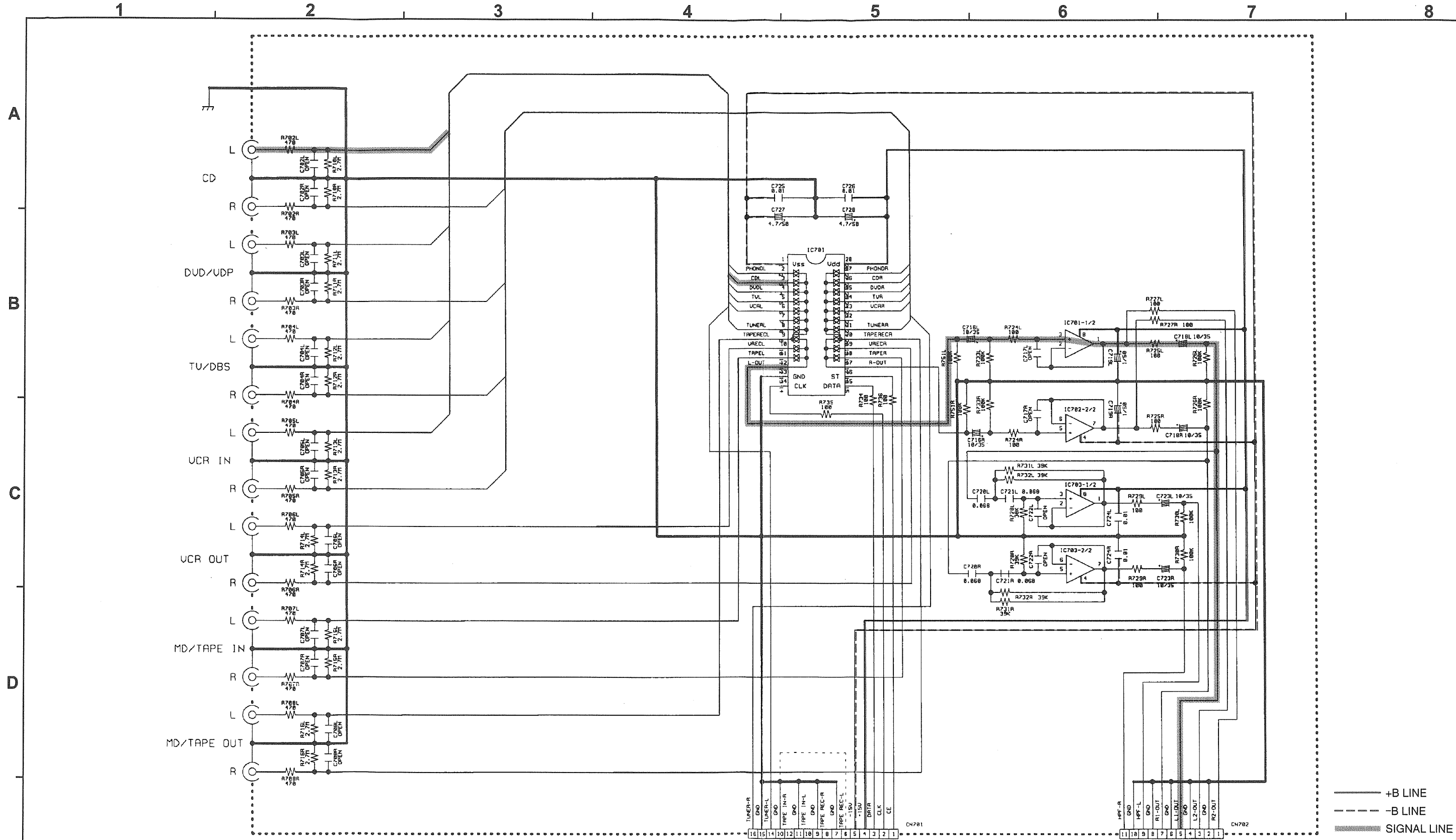

NOTICE
 ALL RESISTANCE VALUES IN OHM. k=1,000 OHM M=1,000,000 OHM
 ALL CAPACITANCE VALUES IN MICRO FARAD. P=MICRO-MICRO FARAD
 EACH VOLTAGE AND CURRENT ARE MEASURED AT NO SIGNAL INPUT
 CONDITION.
 CIRCUIT AND PARTS ARE SUBJECT TO CHANGE WITHOUT PRIOR
 NOTICE.

WARNING:
 Parts marked with this symbol have critical characteristics.
 Use ONLY replacement parts recommended by the manufacture.
CAUTION:
 Before returning the unit to the customer, make sure you make either (1) a
 leakage current check or (2) a line to chassis resistance check. If the leakage
 current exceeds 0.5 milliamps, or if the resistance from chassis to either side
 of the power card is less than 460 kohms, the unit is defective.
WARNING:
 DO NOT return the unit to the customer until the problem is located and
 corrected.

AVR-1601 ONLY

SCHEMATIC DIAGRAMS (2/8)
INPUT

SCHEMATIC DIAGRAMS (3/8)

1 2 3 4 5 6 7 8

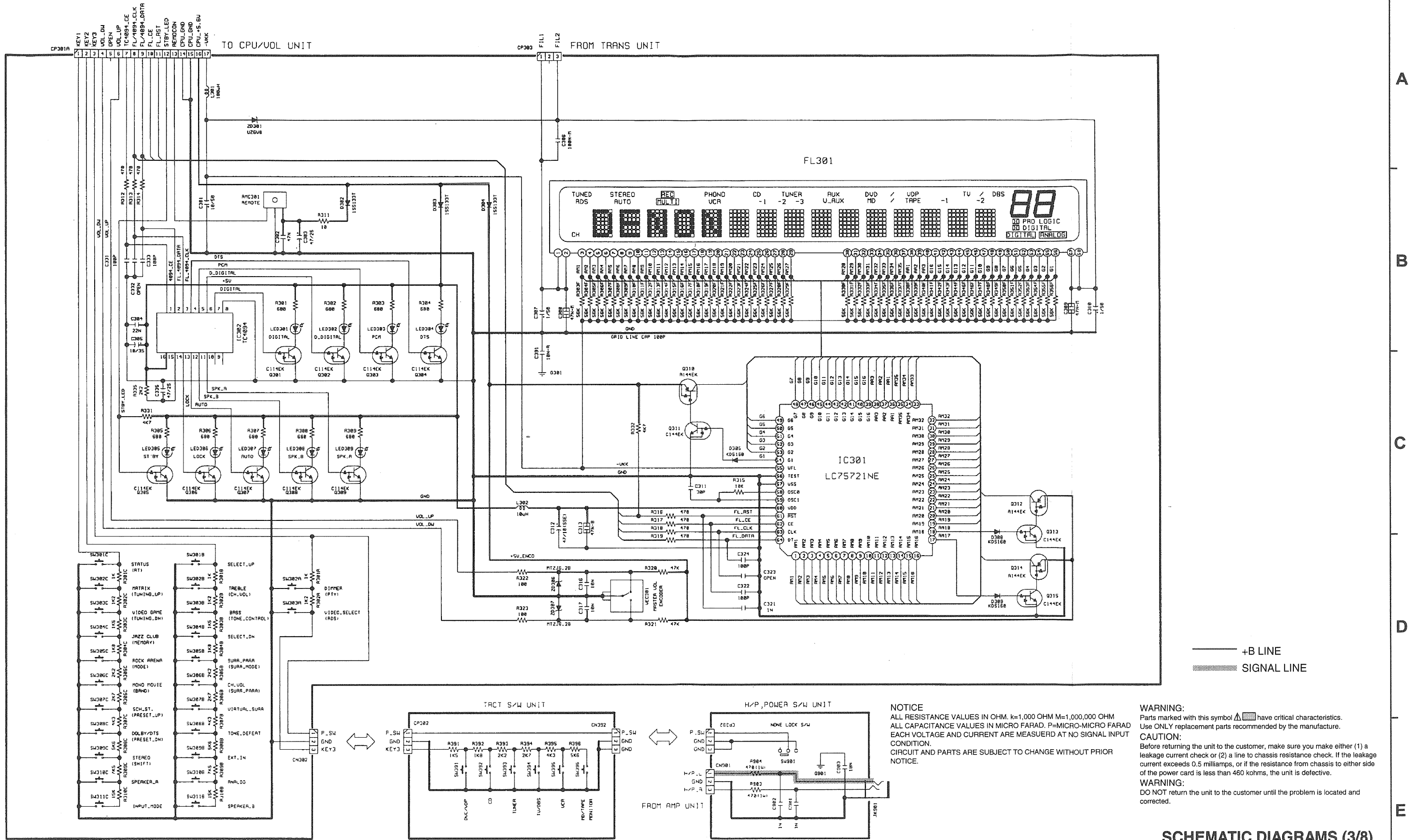

NOTICE
 ALL RESISTANCE VALUES IN OHM. k=1,000 OHM M=1,000,000 OHM
 ALL CAPACITANCE VALUES IN MICRO FARAD. P=MICRO-MICRO FARAD
 EACH VOLTAGE AND CURRENT ARE MEASURED AT NO SIGNAL INPUT
 CONDITION.
 CIRCUIT AND PARTS ARE SUBJECT TO CHANGE WITHOUT PRIOR
 NOTICE.

WARNING:
 Parts marked with this symbol Δ have critical characteristics.
 Use ONLY replacement parts recommended by the manufacture.
CAUTION:
 Before returning the unit to the customer, make sure you make either (1) a
 leakage current check or (2) a line to chassis resistance check. If the leakage
 current exceeds 0.5 milliamperes, or if the resistance from chassis to either side
 of the power card is less than 460 kohms, the unit is defective.
WARNING:
 DO NOT return the unit to the customer until the problem is located and
 corrected.

SCHEMATIC DIAGRAMS (3/8)
FRONT UNIT / TACT S/W UNIT
H/P, POWER S/W UNIT

SCHEMATIC DIAGRAMS (4/8)

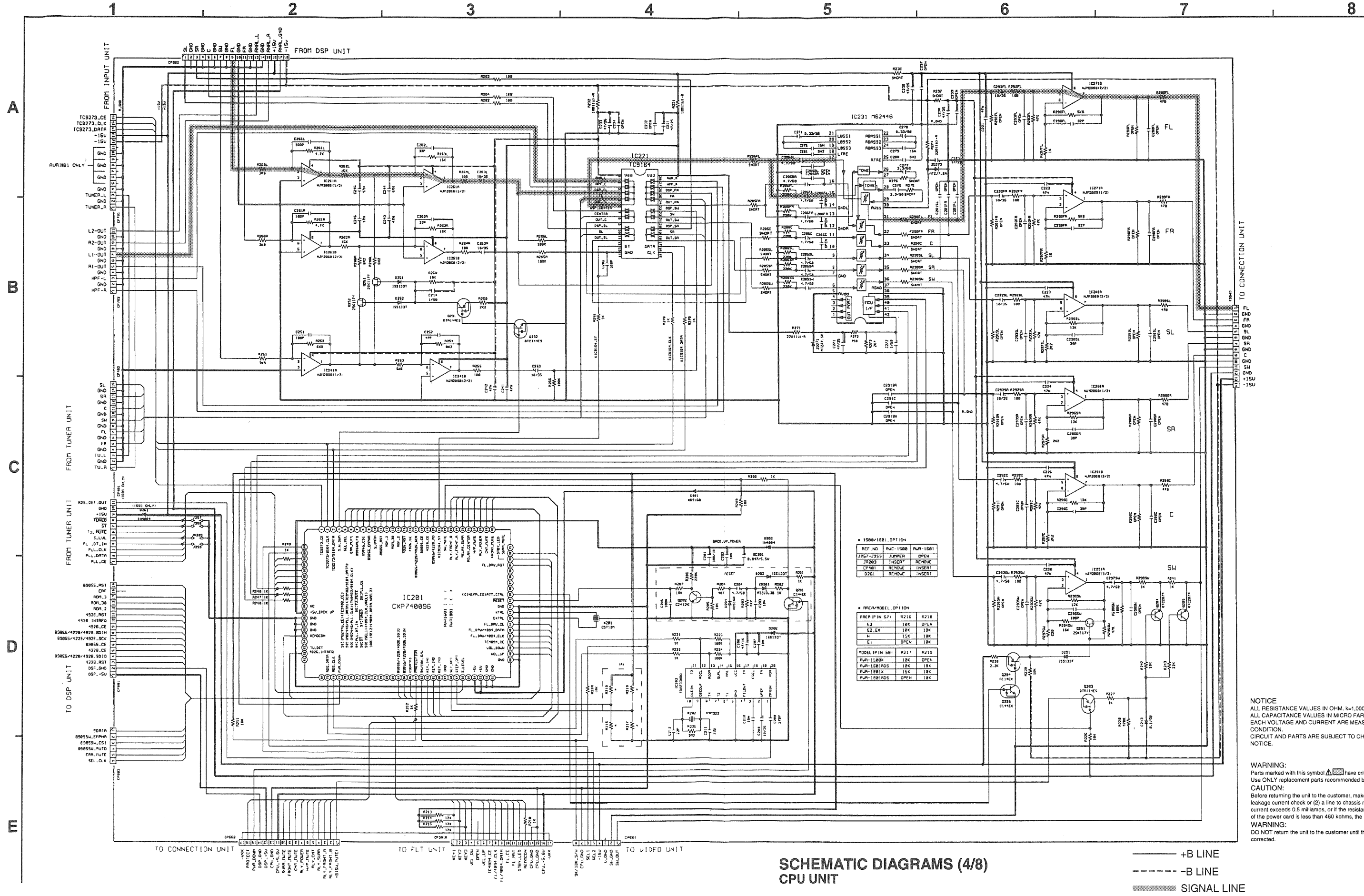

SCHEMATIC DIAGRAMS (4/8)
CPU UNIT

NOTICE
ALL RESISTANCE VALUES IN OHM. k=1,000 OHM M=1,000,000 OHM
ALL CAPACITANCE VALUES IN MICRO FARAD. P=PICTO-MICRO FARAD
EACH VOLTAGE AND CURRENT ARE MEASURED AT NO SIGNAL INPUT
CONDITION.
CIRCUIT AND PARTS ARE SUBJECT TO CHANGE WITHOUT PRIOR
NOTICE.

WARNING:
Parts marked with this symbol have critical characteristics.
Use ONLY replacement parts recommended by the manufacturer.
CAUTION:
Before returning the unit to the customer, make sure you make either (1) a
leakage current check or (2) a line to chassis resistance check. If the leakage
current exceeds 0.5 milliamperes, or if the resistance from chassis to either side
of the power cord is less than 460 kohms, the unit is defective.
WARNING:
DO NOT return the unit to the customer until the problem is located and
corrected.

SCHEMATIC DIAGRAMS (5/8)

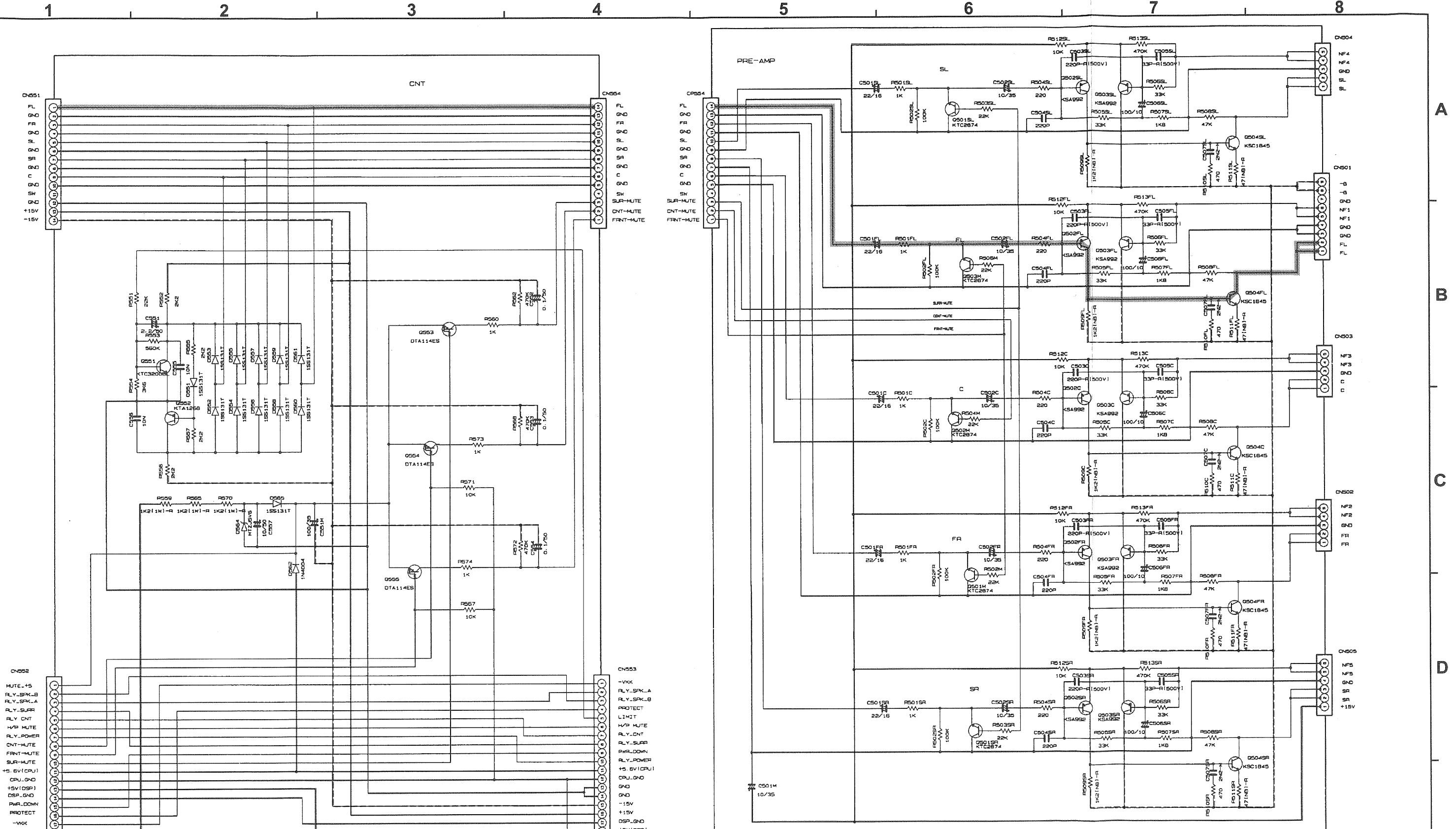

CN551
FL
FR
GND
SL
SR
SW
SUR-MUTE
CNT-MUTE
FRNT-MUTE
+15V
-15V

CN552
MUTE-15
RLY_SPK-B
RLY_SPK-A
RLY_SUR
LIMIT
HVP MUTE
RLY_CNT
RLY_SURR
PWR_DOWN
RLY_POWER
CNT-MUTE
FRNT-MUTE
SUR-MUTE
+5_BV(CPU)
CPU_GND
+5V(DSP)
DSP_GND
PWR_DOWN
-VKK

CN553
-VKK
RLY_SPK-A
RLY_SPK-B
PROTECT
LIMIT
HVP MUTE
RLY_CNT
RLY_SURR
PWR_DOWN
RLY_POWER
+5_BV(CPU)
CPU_GND
GND
-15V
+15V
DSP_GND
+5V(DSP)
GND
MUTE-15

NOTICE
ALL RESISTANCE VALUES IN OHM, k=1,000 OHM M=1,000,000 OHM
ALL CAPACITANCE VALUES IN MICRO FARAD, P=MICRO-MICRO FARAD
EACH VOLTAGE AND CURRENT ARE MEASURED AT NO SIGNAL INPUT
CONDITION.
CIRCUIT AND PARTS ARE SUBJECT TO CHANGE WITHOUT PRIOR
NOTICE.

WARNING:
Parts marked with this symbol Δ have critical characteristics.
Use ONLY replacement parts recommended by the manufacturer.
CAUTION:
Before returning the unit to the customer, make sure you make either (1) a
leakage current check or (2) a line to chassis resistance check. If the leakage
current exceeds 0.5 millamps, or if the resistance from chassis to either side
of the power card is less than 460 kohms, the unit is defective.
WARNING:
DO NOT return the unit to the customer until the problem is located and
corrected.

— +B LINE
- - - -B LINE
▨ SIGNAL LINE

SCHEMATIC DIAGRAMS (5/8)
CNT UNIT / PRE-AMP UNIT

A
B
C
D
E

SCHEMATIC DIAGRAMS (6/8)

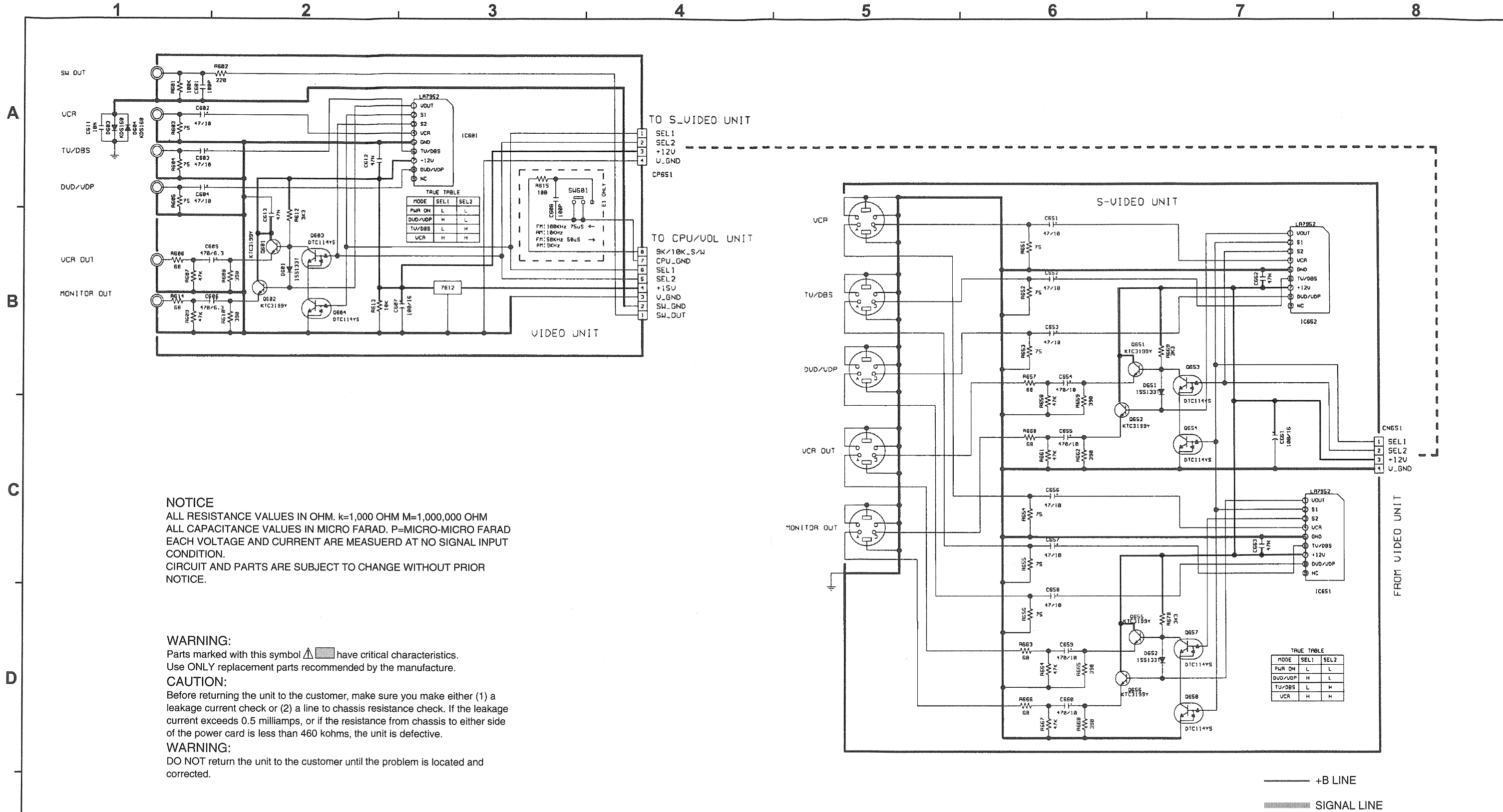

SCHEMATIC DIAGRAMS (6/8)
 VIDEO UNIT / S-VIDEO UNIT

SCHEMATIC DIAGRAMS (7/8)

1 2 3 4 5 6 7 8

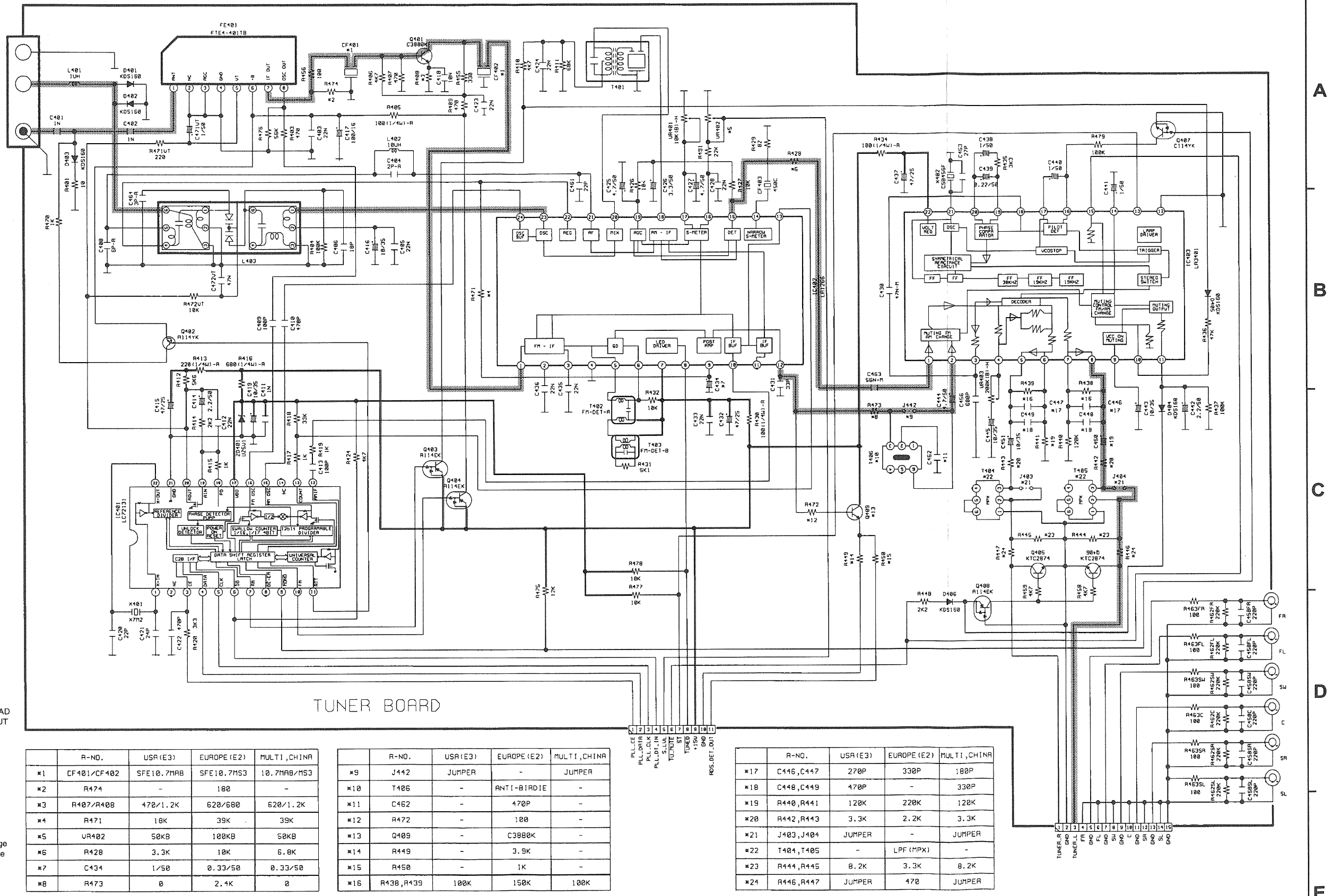

SCHEMATIC DIAGRAMS (7/8)
TUNER UNIT

SCHEMATIC DIAGRAMS (8/8)

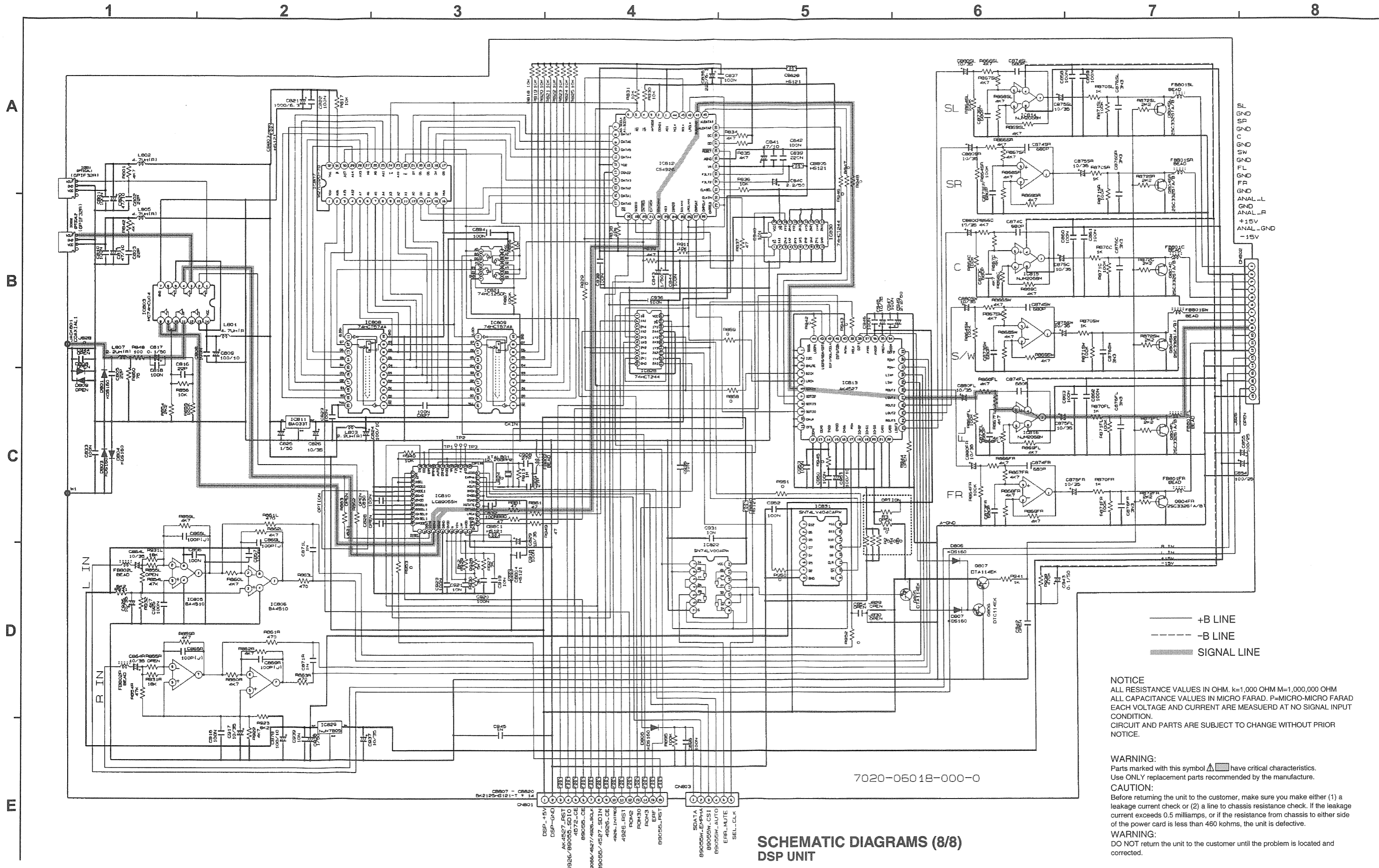

SCHEMATIC DIAGRAMS (8/8)
DSP UNIT

NOTICE
 ALL RESISTANCE VALUES IN OHM. K=1,000 OHM M=1,000,000 OHM
 ALL CAPACITANCE VALUES IN MICRO FARAD. P=MICRO-MICRO FARAD
 EACH VOLTAGE AND CURRENT ARE MEASURED AT NO SIGNAL INPUT
 CONDITION.
 CIRCUIT AND PARTS ARE SUBJECT TO CHANGE WITHOUT PRIOR
 NOTICE.

WARNING:
 Parts marked with this symbol Δ have critical characteristics.
 Use ONLY replacement parts recommended by the manufacture.

CAUTION:
 Before returning the unit to the customer, make sure you make either (1) a
 leakage current check or (2) a line to chassis resistance check. If the leakage
 current exceeds 0.5 milliamps, or if the resistance from chassis to either side
 of the power card is less than 460 kohms, the unit is defective.

WARNING:
 DO NOT return the unit to the customer until the problem is located and
 corrected.

PACKING VIEW

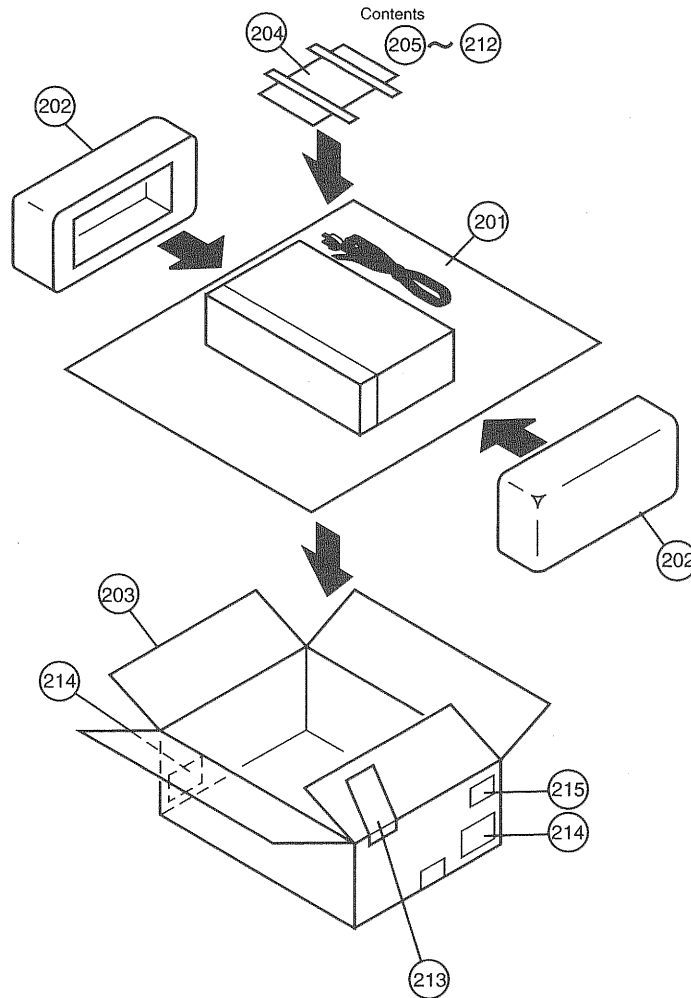

PARTS LIST OF PACKING & ACCESSORIES

Note: The symbols in the column "Remarks" indicate the following destinations.
 E3: U.S.A. model, Csnada model E1C: China model
 EU: U.S.A. model (AVR-681) E1H: Hong Kong model
 E2: Europe model E1T: Taiwan R.O.C. model
 E1: Asia model

Ref. No.	Part No.	Part Name	Remarks	Q'ty	Ref. No.	Part No.	Part Name	Remarks	Q'ty
201	960 0185 601	Set poly bag	6330210019000	1	212	963 0061 300	AC plug adapter	L10928300310A for E1T	1
202	960 0193 101	Cushion	6230210154000	1	213	515 0817 009	DEL Warranty home	for E3,EU	1
203	963 0054 100	Carton case	6007210150000 for E3,E2	1	214	—	Control label	5500014920010	2
203	963 0054 113	Carton case	6007210150040 for EU	1	215	—	UPC label	5507002330010 for E3	1
203	963 0054 553	Carton case	6007210150100 for E1H	1	215	—	UPC label	5507002330040 for EU	1
203	963 0054 540	Carton case	6007210150030 for E1,E1C,E1T	1	215	—	POS label	5507002330030 for E2	1
204	963 0045 106	Poly bag	6330000240000	1	★	—	Label (RDS,RADIO TEXT)	5507051670010 for E2	2
205	963 0056 001	Instruction manual	for E3,EU	1	★	—	Label (CCIB)	5500020160030 for E1C	2
205	963 0056 014	Instruction manual	for E2	1	★	513 3341 000	Carton label (A)	for E1,E1C,E1H,E1T	1
205	963 0056 043	Instruction manual	for E1,E1C,E1H,E1T	1	★	513 3342 009	Carton label (B)	for E1,E1C,E1H,E1T	1
206	963 0056 027	Instruction manual	for E1C	1	★	513 9111 001	Color label (Gold)	for E1,E1C(Gold model), E1H,E1T	2
207	515 0867 004	SS. list		1	★	963 0055 918	Pad	6240210144000 for E1H	2
208	963 0052 306	AM loop antenna	E605010090000	1					
209	963 0052 209	FM antenna	E605000030010	1					
210	960 0193 402	Remocon RC-875	8300875000010	1					
211	—	Battery (R6P/AA)	G670001R50010	2					

DENON

NIPPON COLUMBIA CO., LTD.

14-14, AKASAKA 4-CHOME, MINATO-KU, TOKYO 107-8011 JAPAN
Telephone: 03 (3584) 8111