

DENON

For U.S.A., Canada, Europe,
Asia, China, Hong Kong &
Taiwan R.O.C. model

Hi-Fi Component

SERVICE MANUAL

MODEL AVR-1602/682

AV SURROUND RECEIVER

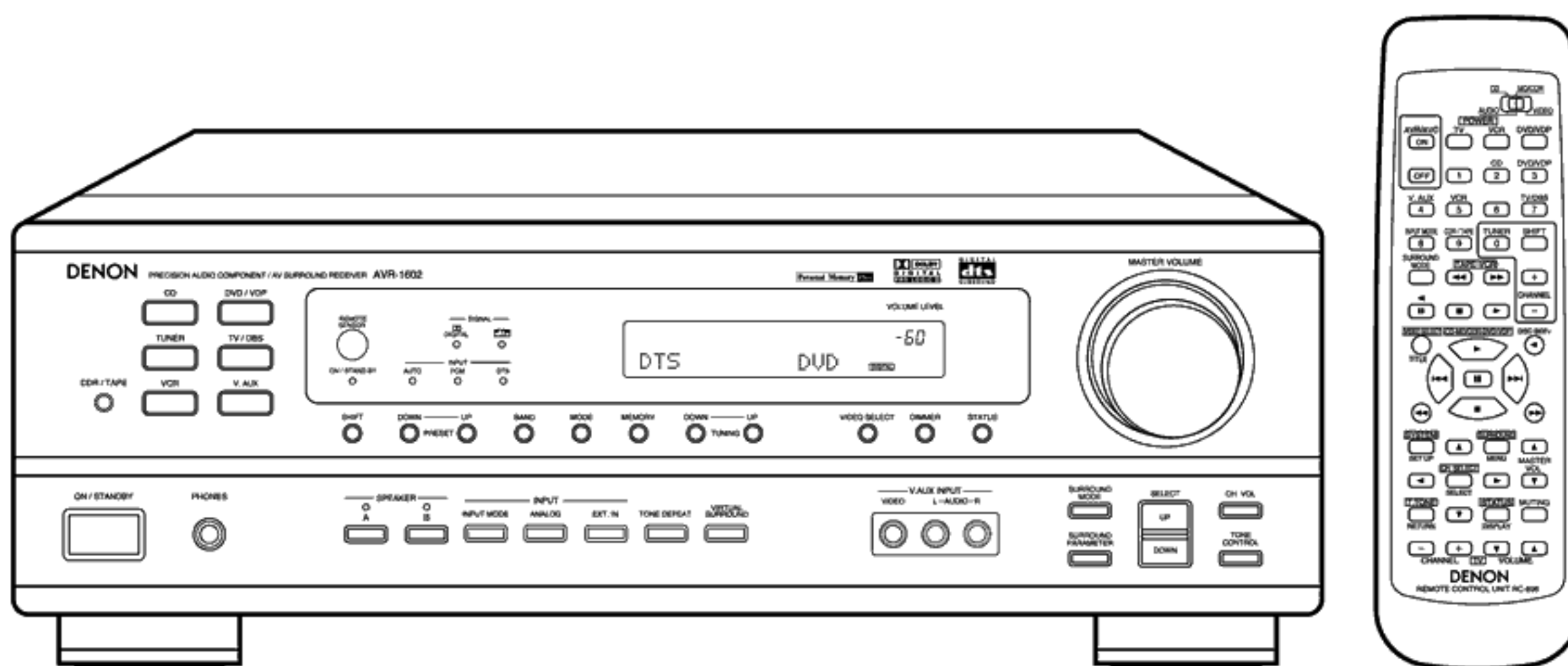

● Some illustrations using in this service manual are slightly different from the actual set.

NIPPON COLUMBIA CO., LTD.

14-14, AKASAKA 4-CHOME, MINATO-KU, TOKYO 107-8011 JAPAN
Telephone: 03 (3584) 8111

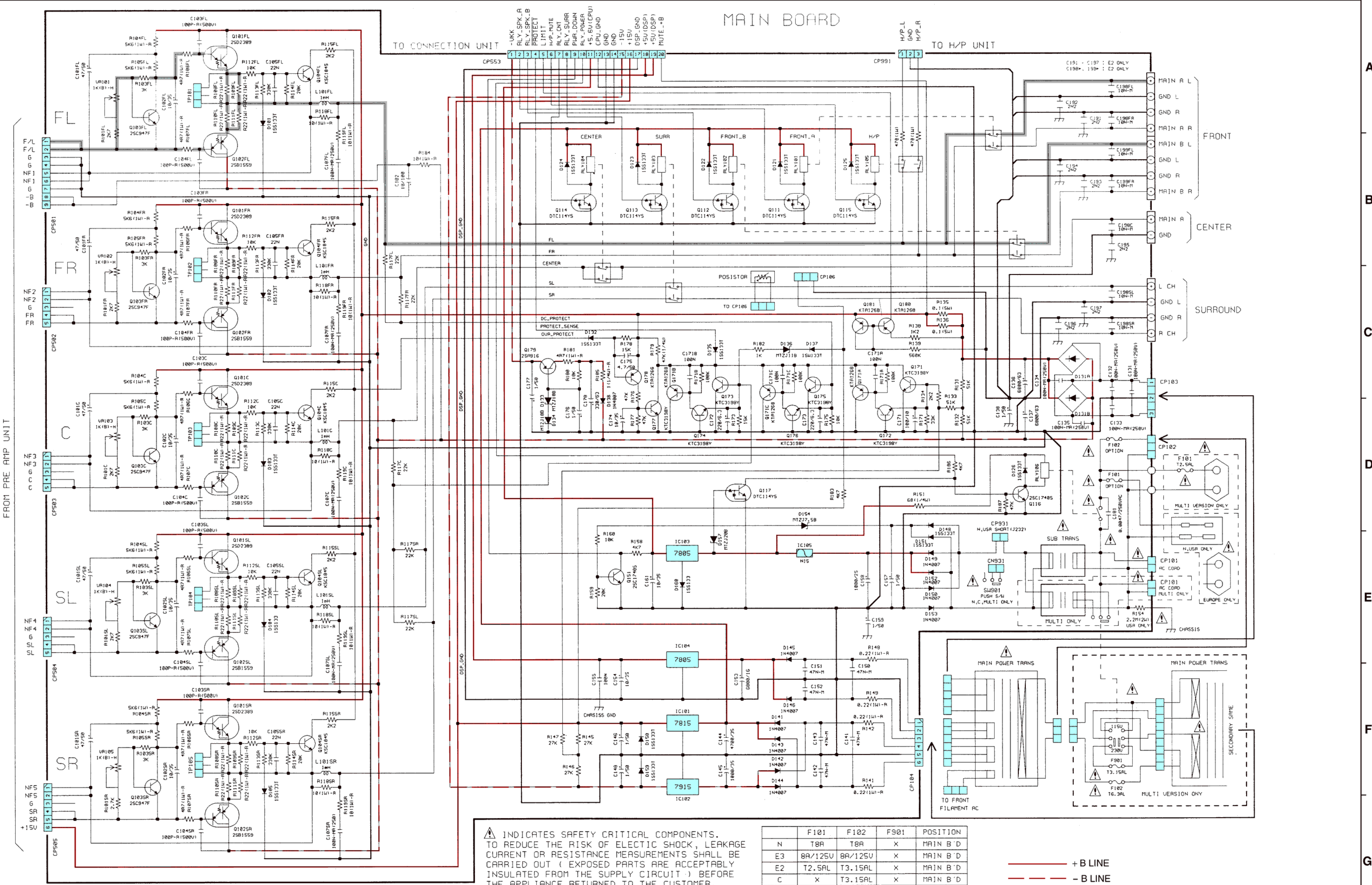

NOTICE
 ALL RESISTANCE VALUES IN OHM. K=1,000 OHM M=1,000,000 OHM
 ALL CAPACITANCE VALUES IN MICRO FARAD. P=MICRO-MICRO FARAD
 EACH VOLTAGE AND CURRENT ARE MEASURED AT MO SIGNAL INPUT
 CONDITION.
 CIRCUIT AND PARTS ARE SUBJECT TO CHANGE WITHOUT PRIOR
 NOTICE.

⚠ INDICATES SAFETY CRITICAL COMPONENTS.
 TO REDUCE THE RISK OF ELECTRIC SHOCK, LEAKAGE
 CURRENT OR RESISTANCE MEASUREMENTS SHALL BE
 CARRIED OUT (EXPOSED PARTS ARE ACCEPTABLY
 INSULATED FROM THE SUPPLY CIRCUIT) BEFORE
 THE APPLIANCE RETURNED TO THE CUSTOMER.

WARNING:
 Parts marked with this symbol ⚠ have critical characteristics.
 Use ONLY replacement parts recommended by the manufacture.

CAUTION:
 Before returning the unit to the customer, make sure you make either (1) a
 leakage current check or (2) a line to chassis resistance check. If the leakage
 current exceeds 0.5 milliamps, or if the resistance from chassis to either side
 of the power card is less than 460kohms, the unit is defective.

WARNING:
 DO NOT return the unit to the customer until the problem is located and
 corrected.

	F101	F102	F901	POSITION
N	T8A	T8A	X	MAIN B'D
E3	8A/125V	8A/125V	X	MAIN B'D
E2	T2.5AL	T3.15AL	X	MAIN B'D
C	X	T3.15AL	X	MAIN B'D
H,T,E1	T2.5AL	T6.3AL	T3.15AL	U. SEL B'D

— + B LINE
 - - - - - B LINE
 ——— SIGNAL LINE

FROM

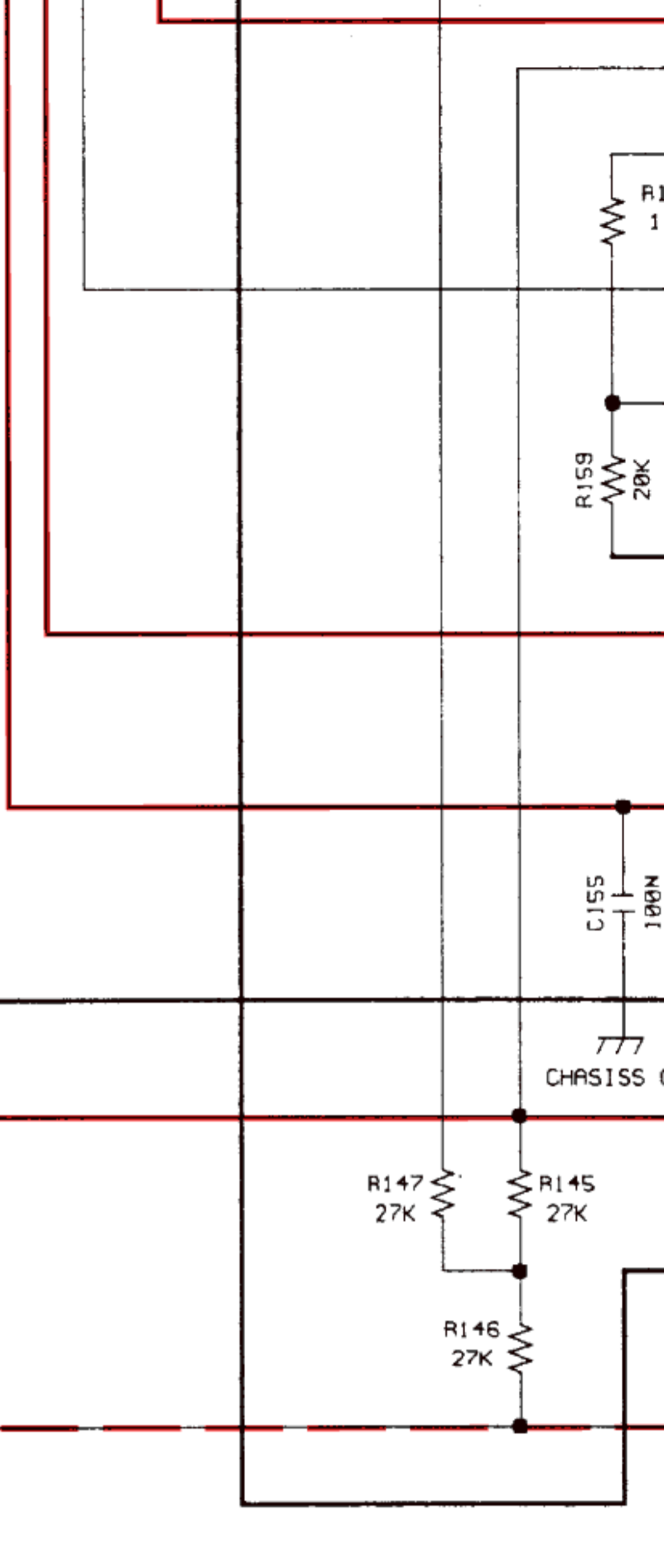
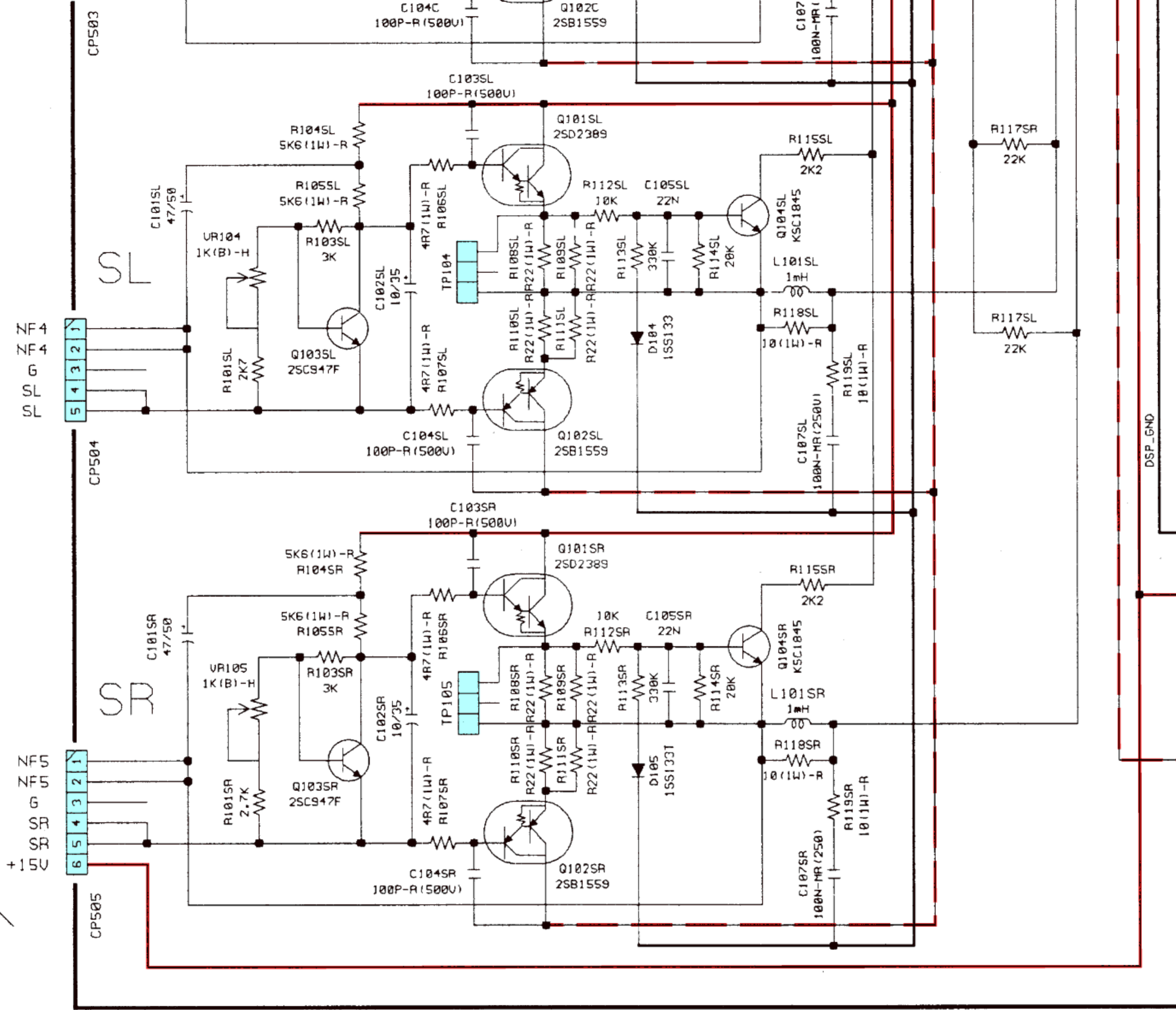

NOTICE
 ALL RESISTANCE VALUES IN OHM. k=1,000 OHM M=1,000,000 OHM
 ALL CAPACITANCE VALUES IN MICRO FARAD. P=MICRO-MICRO FARAD
 EACH VOLTAGE AND CURRENT ARE MEASURED AT NO SIGNAL INPUT
 CONDITION.
 CIRCUIT AND PARTS ARE SUBJECT TO CHANGE WITHOUT PRIOR
 NOTICE.

⚠ INDICATES SAFETY
 TO REDUCE THE RISK OF
 CURRENT OR RESISTANCE
 CARRIED OUT (EXPOSED
 INSULATED FROM THE SU
 THE APPLIANCE RETURNED

WARNING:
 Parts marked with this symbol /
 Use ONLY replacement parts re
CAUTION:
 Before returning the unit to the c
 leakage current check or (2) a li
 current exceeds 0.5 milliamps, c
 of the power card is less than 4

WARNING:
 DO NOT return the unit to the c
 corrected.

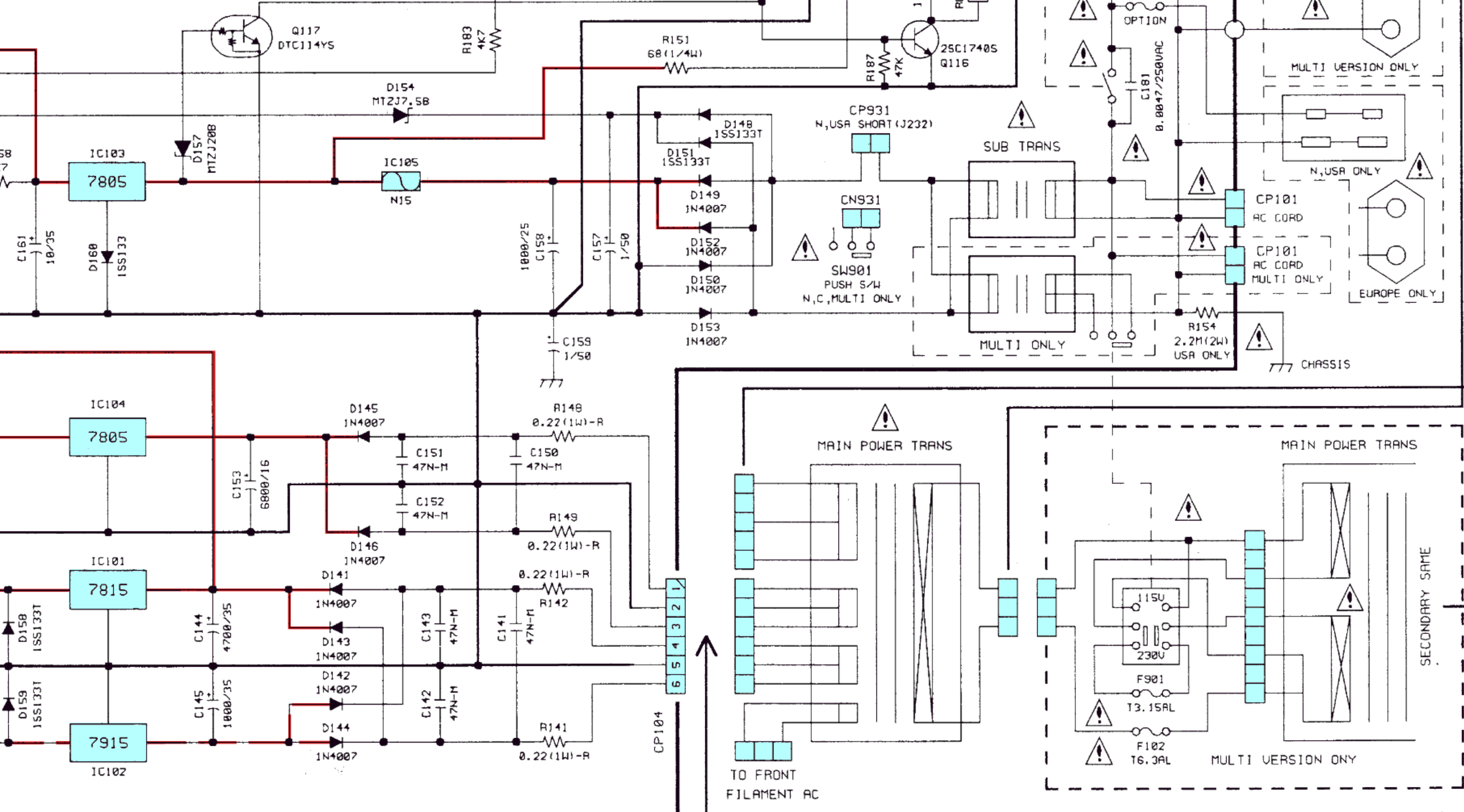

AL COMPONENTS.
 CTIC SHOCK, LEAKAGE
 SUREMENTS SHALL BE
 S ARE ACCEPTABLY
 CIRCUIT) BEFORE
 THE CUSTOMER.

	F101	F102	F901	POSITION
N	T8A	T8A	X	MAIN B'D
E3	8A/125V	8A/125V	X	MAIN B'D
E2	T2.5AL	T3.15AL	X	MAIN B'D
C	X	T3.15AL	X	MAIN B'D
H,T,E1	T2.5AL	T6.3AL	T3.15AL	U.SEL B'D

— + B LINE
 - - - - - B LINE
 ——— SIGNAL LINE

ve critical characteristics.
 ded by the manufacture.
 , make sure you make either (1) a
 ssis resistance check. If the leakage
 esistance from chassis to either side
 , the unit is defective.

until the problem is located and

SCHEMATIC DIAGRAMS(5/7) MAIN P.W.B. UNIT

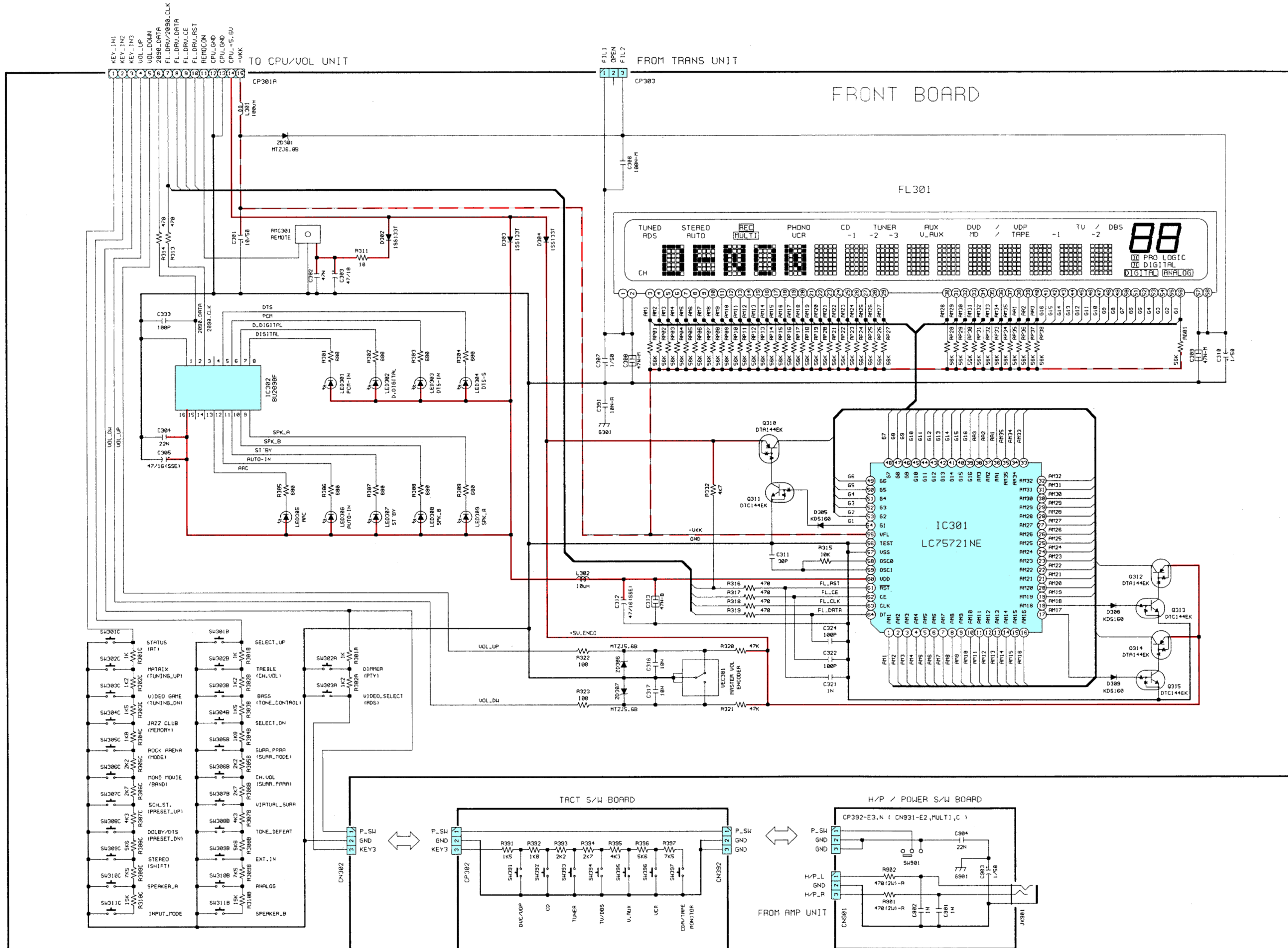

ALL RESISTANCE VALUES IN OHM. K=1,000 OHM M=1,000,000 OHM
 ALL CAPACITANCE VALUES IN MICRO FARAD. P=MICRO-MICRO FARAD
 EACH VOLTAGE AND CURRENT ARE MEASURED AT NO SIGNAL INPUT
 CONDITION.
 CIRCUIT AND PARTS ARE SUBJECT TO CHANGE WITHOUT PRIOR
 NOTICE.

WARNING:
 Parts marked with this symbol \triangle have critical characteristics.
 Use ONLY replacement parts recommended by the manufacturer.

CAUTION:
 Before returning the unit to the customer, make sure you make either (1) a
 leakage current check or (2) a line to chassis resistance check. If the leakage
 current exceeds 0.5 millamps, or if the resistance from chassis to either side
 of the power card is less than 460kohms, the unit is defective.

WARNING:
 DO NOT return the unit to the customer until the problem is located and
 corrected.

— + B LINE
 - - - - - B LINE

SCHEMATIC DIAGRAMS(6/7)

1

2

3

4

5

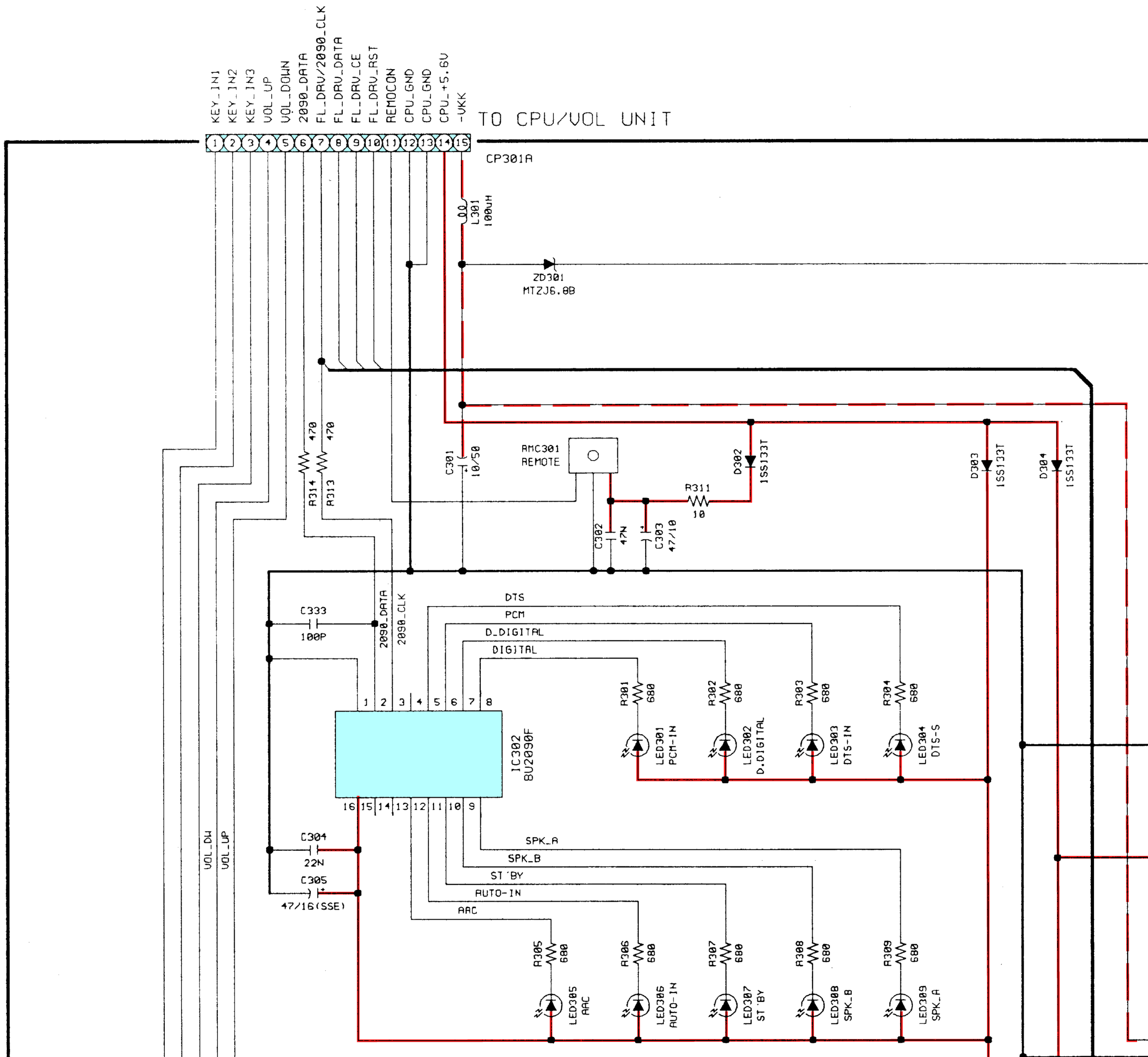

FIL1
OPEN
FIL2
FROM TRANS UNIT

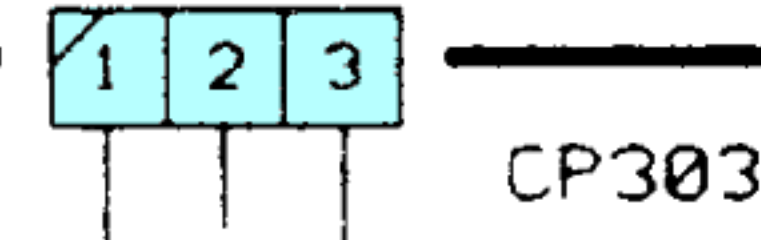

FRONT BOARD

FL301

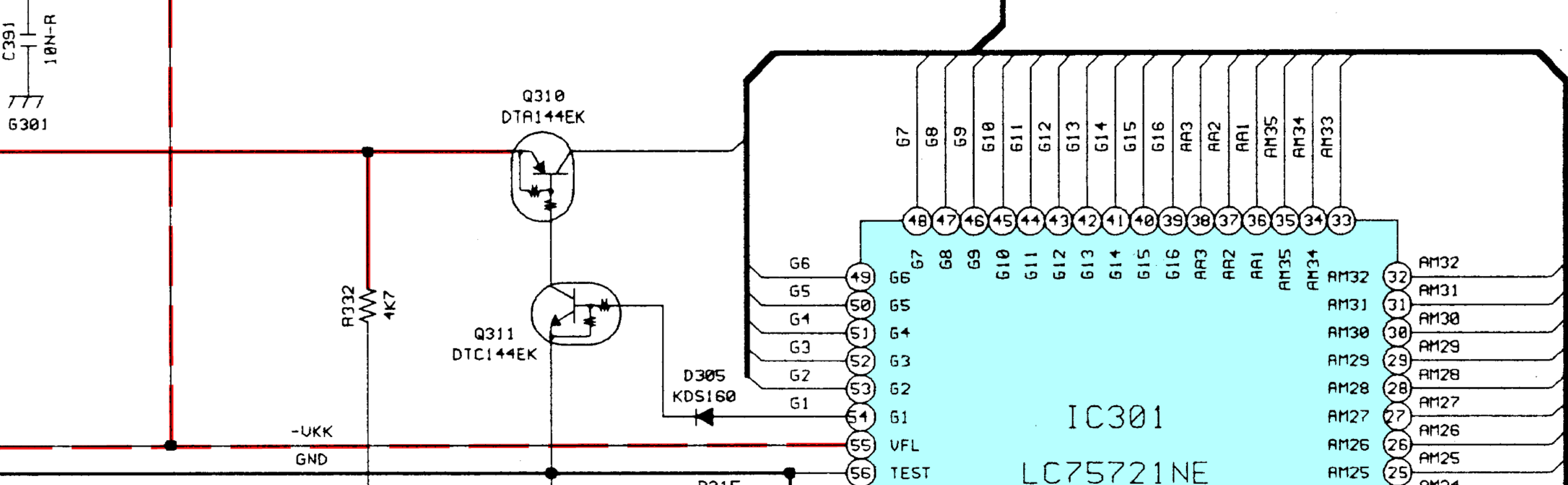
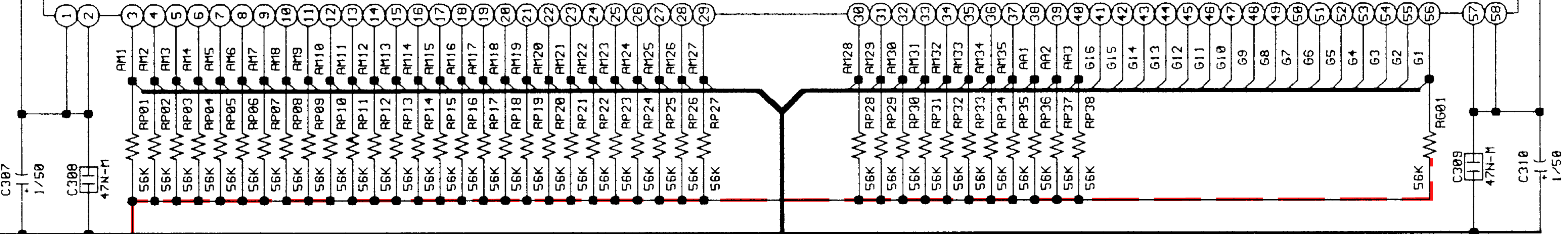
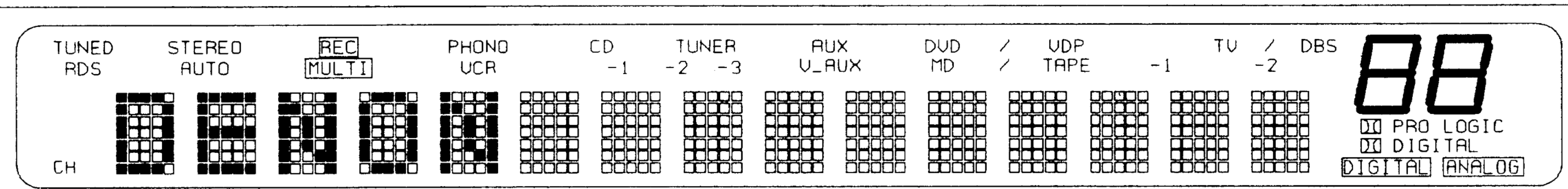

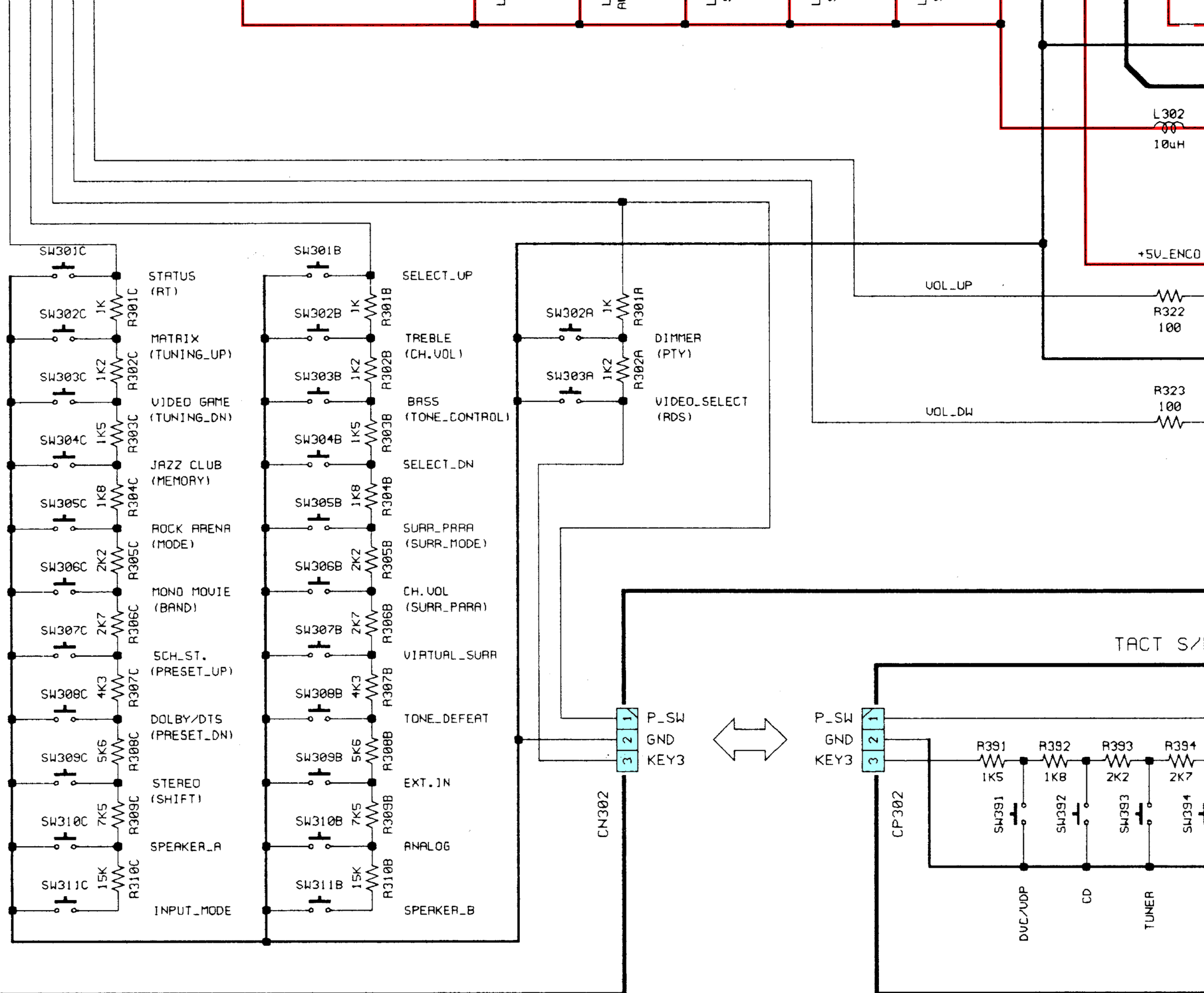

ALL RESISTANCE VALUES IN OHM. k=1,000 OHM M=1,000,000 OHM
 ALL CAPACITANCE VALUES IN MICRO FARAD. P=MICRO-MICRO FARAD
 EACH VOLTAGE AND CURRENT ARE MEASUERD AT MO SIGNAL INPUT
 CONDITION.

CIRCUIT AND PARTS ARE SUBJECT TO CHANGE WITHOUT PRIOR
 NOTICE.

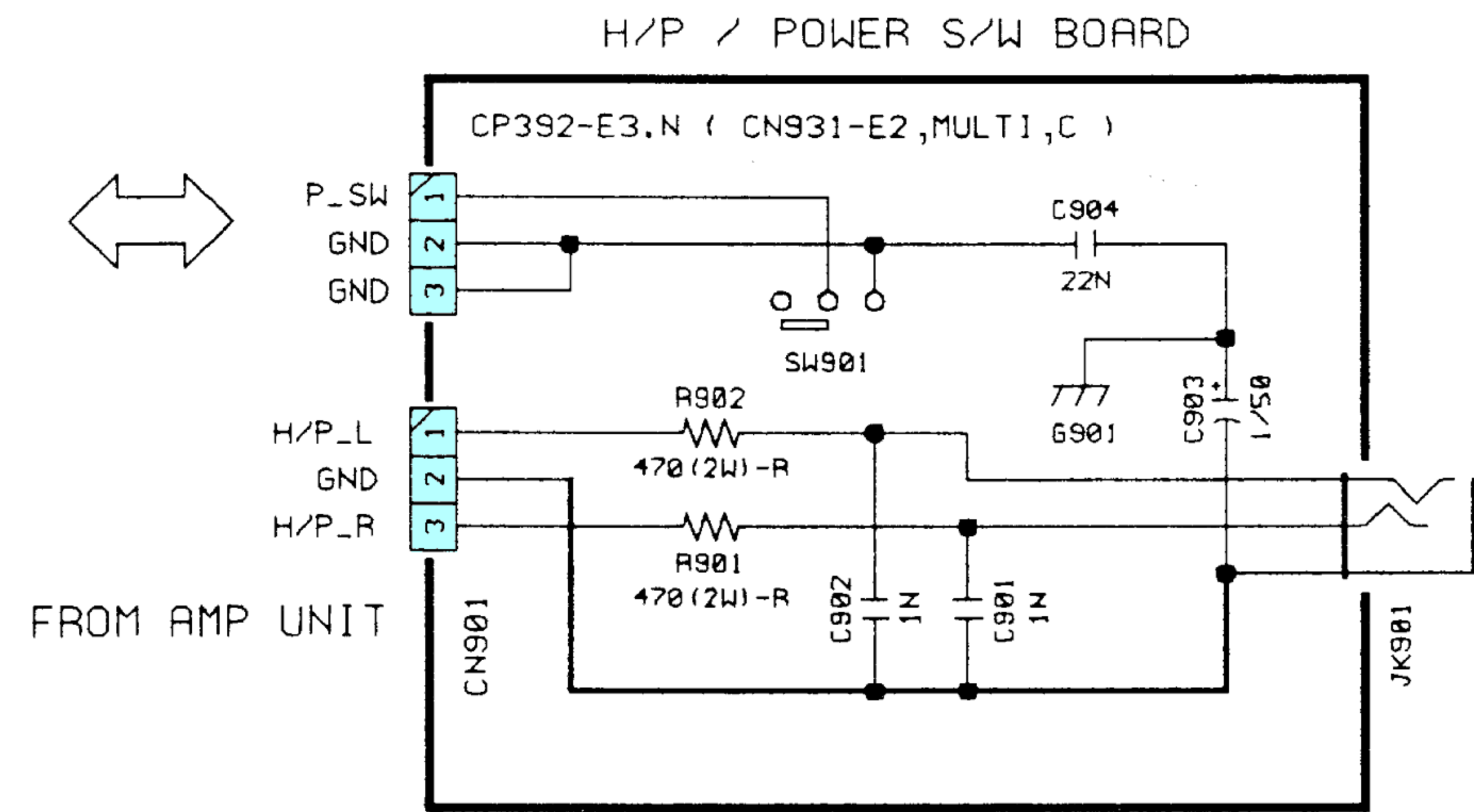
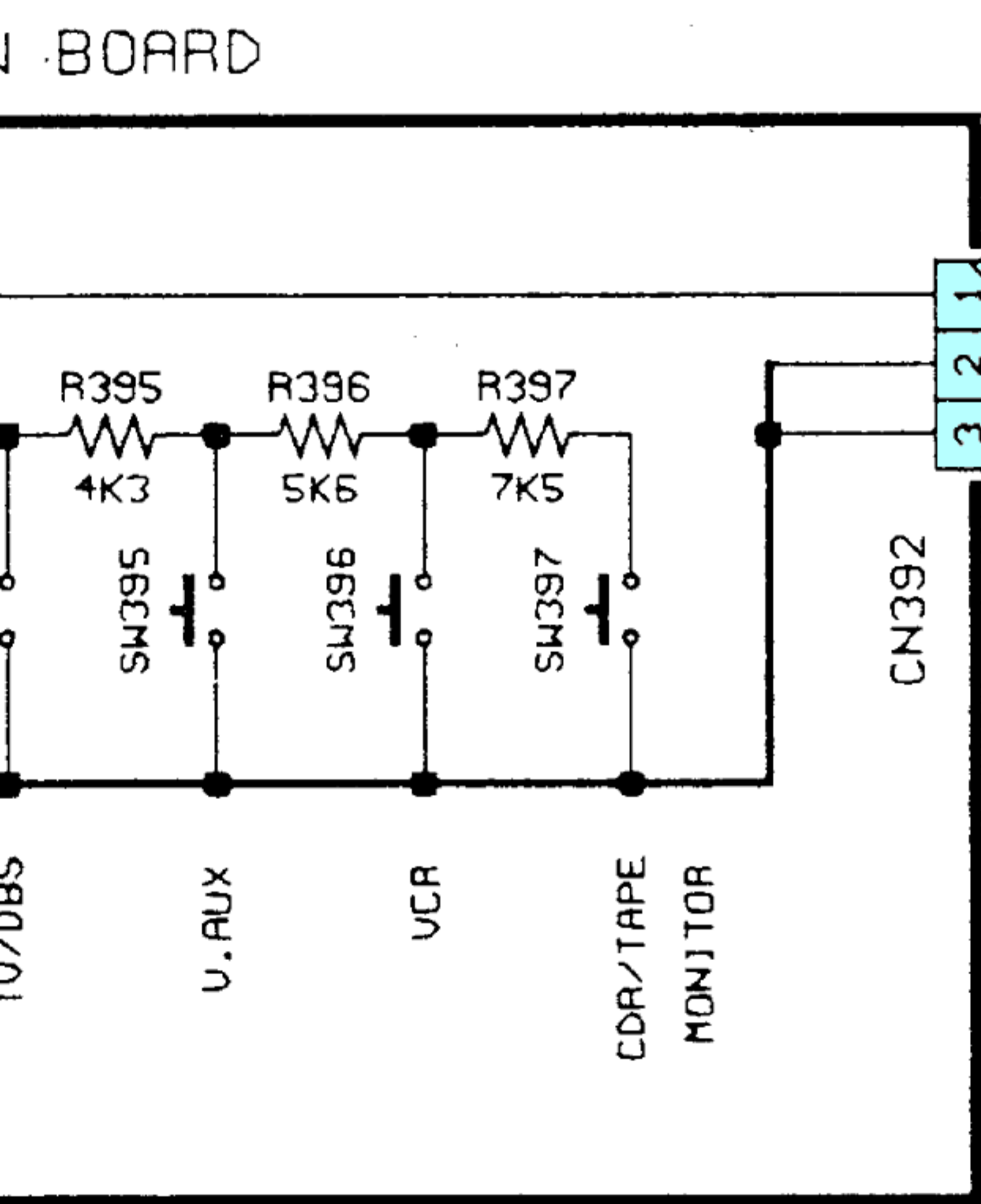
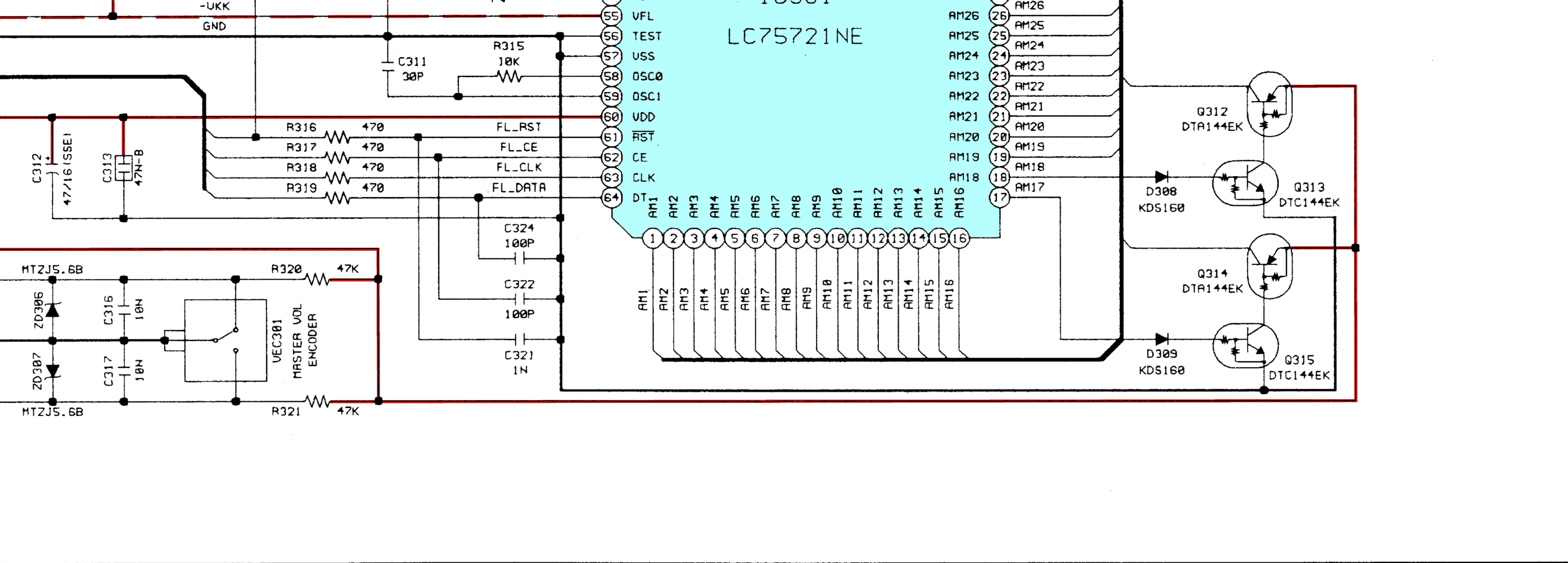

WARNING:

Parts marked with this symbol  have critical characteristics. Use ONLY replacement parts recommended by the manufacture.

CAUTION:

Before returning the unit to the customer, make sure you make either (1) a leakage current check or (2) a line to chassis resistance check. If the leakage current exceeds 0.5 milliamps, or if the resistance from chassis to either side of the power card is less than 460kohms, the unit is defective.

WARNING:

DO NOT return the unit to the customer until the problem is located and corrected.



SCHEMATIC DIAGRAMS(6/7)
 FRONT P.W.B. UNIT
 TACT S/W P.W.B. UNIT
 H/P & POWER S/W P.W.B. UNIT

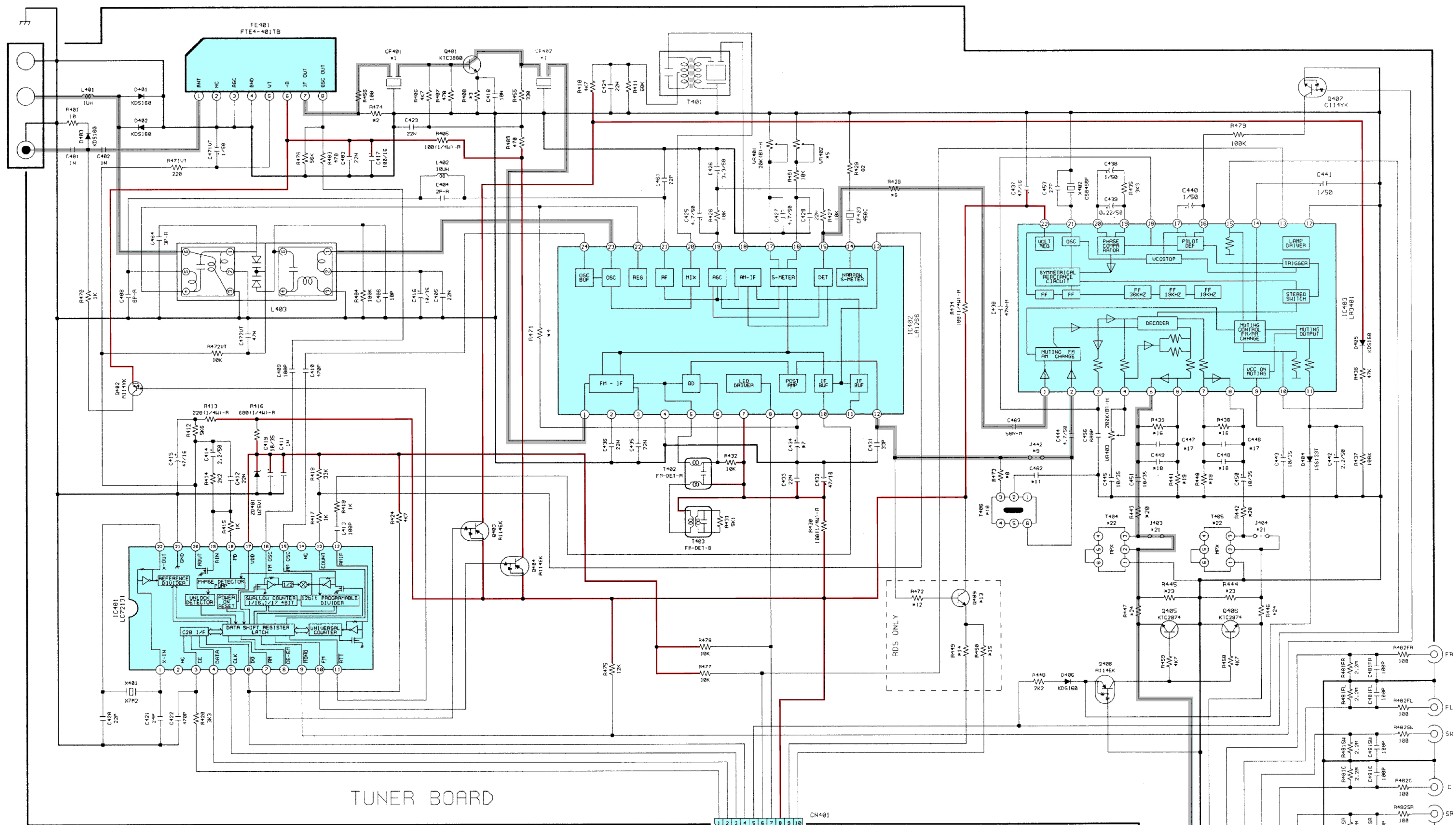

TUNER BOARD

R-NO.	USA(E3)	EUROPE(E2)	MULTI,CHINA
*1	CF401/CF402	SFE10.7MAB	10.7MAB/MS3
*2	R474	-	180
*3	R407/R408	470/1.2K	620/680
*4	R471	18K	39K
*5	UR402	50KB	100KB
*6	R428	3.3K	10K
*7	C434	1/50	0.33/50
*8	R473	-	2.4K

R-NO.	USA(E3)	EUROPE(E2)	MULTI,CHINA
*9	J442	JUMPER	JUMPER
*10	T406	-	ANT1-BIRDIE
*11	C462	-	470P
*12	R472	-	100
*13	Q409	-	KTC3880
*14	R449	-	3.9K
*15	R450	-	1K
*16	R438,R439	100K	150K

R-NO.	USA(E3)	EUROPE(E2)	MULTI,CHINA
*17	C446,C447	270P	330P
*18	C448,C449	470P	330P
*19	R440,R441	120K	220K
*20	R442,R443	3.3K	2.2K
*21	J403,J404	JUMPER	JUMPER
*22	T404,T405	-	LPF(MPX)
*23	R444,R445	8.2K	3.3K
*24	R446,R447	JUMPER	470

NOTICE

ALL RESISTANCE VALUES IN OHM. k=1,000 OHM M=1,000,000 OHM
 ALL CAPACITANCE VALUES IN MICRO FARAD. P=MICRO-MICRO FARAD
 EACH VOLTAGE AND CURRENT ARE MEASURED AT MO SIGNAL INPUT
 CONDITION.
 CIRCUIT AND PARTS ARE SUBJECT TO CHANGE WITHOUT PRIOR
 NOTICE.

WARNING:

Parts marked with this symbol Δ have critical characteristics.
 Use ONLY replacement parts recommended by the manufacture.

CAUTION:

Before returning the unit to the customer, make sure you make either (1) a leakage current check or (2) a line to chassis resistance check. If the leakage current exceeds 0.5 millamps, or if the resistance from chassis to either side of the power card is less than 460kohms, the unit is defective.

WARNING:

DO NOT return the unit to the customer until the problem is located and corrected.

— + B LINE
 — SIGNAL LINE

SCHEMATIC DIAGRAMS(7/7)

1 2 3 4 5

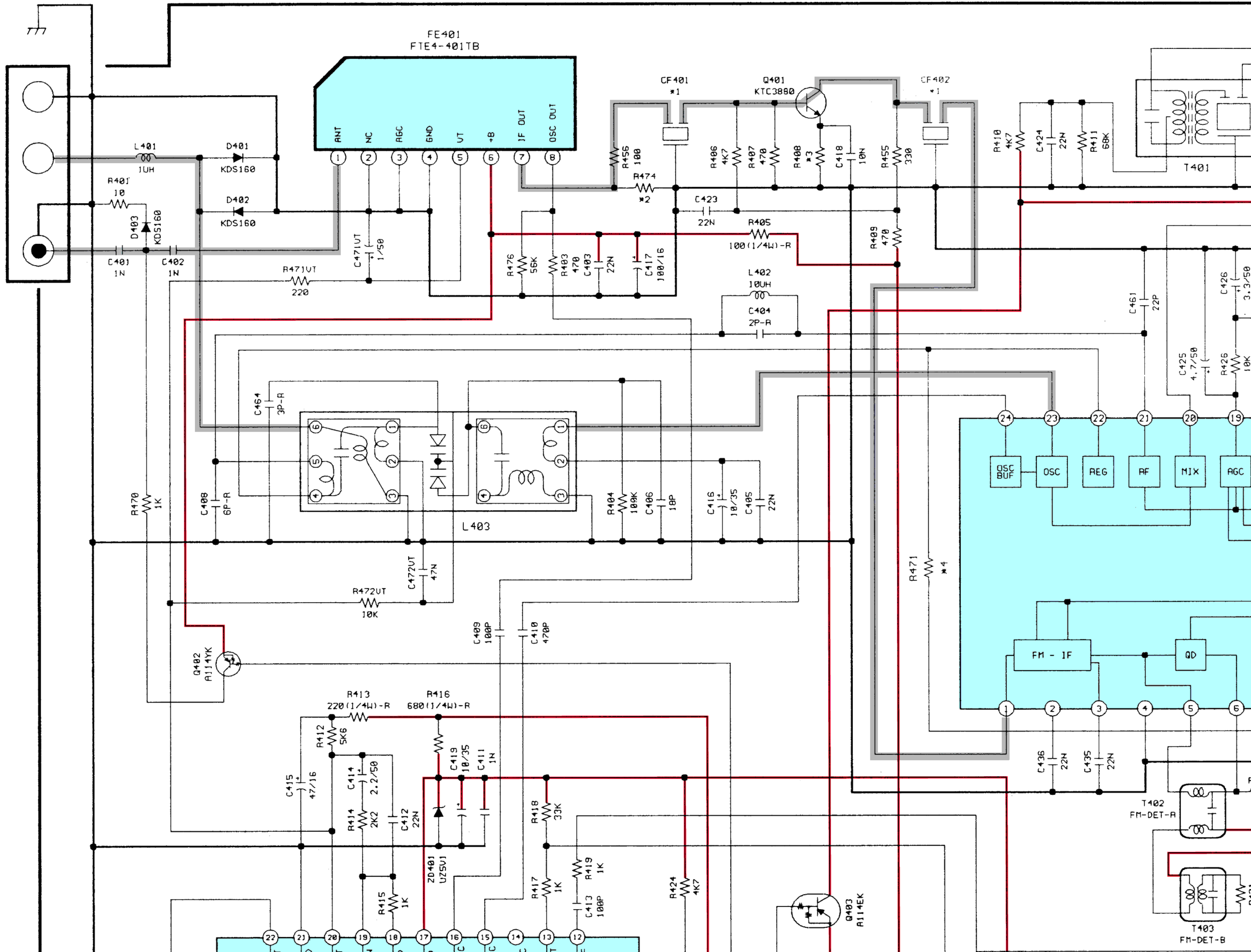

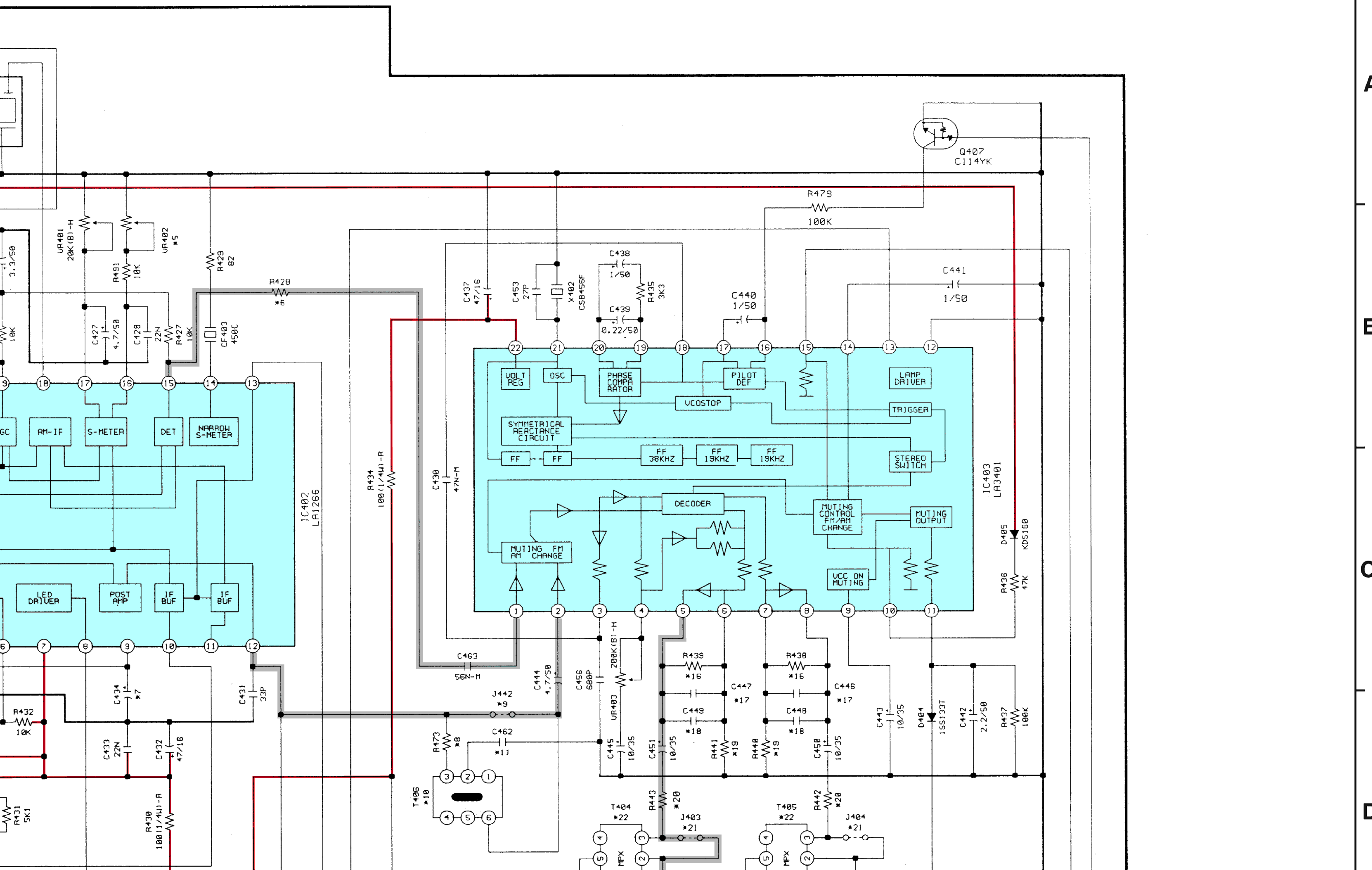

A

B

C

D

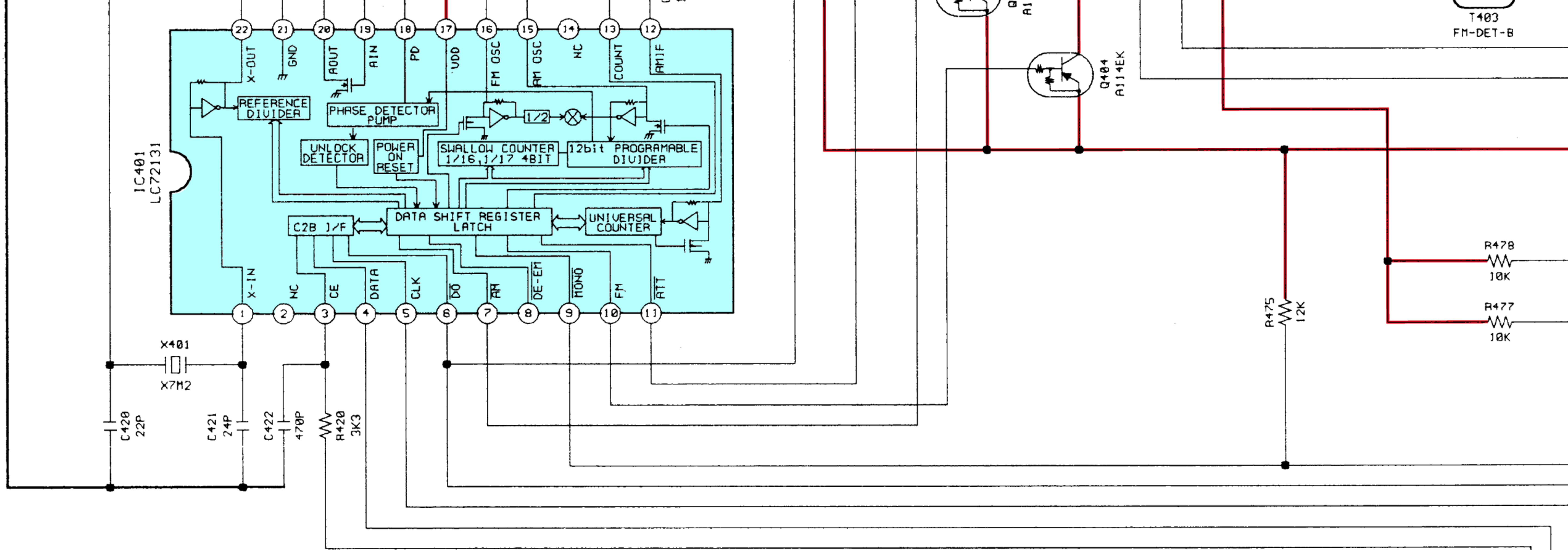

TUNER BOARD

	R-NO.	USA (E3)	EUROPE (E2)	MULTI ,CHINA
*1	CF401/CF402	SFE10.7MA8	SFE10.7MS3	10.7MA8/MS3
*2	R474	-	180	-
*3	R407/R408	470/1.2K	620/680	620/1.2K
*4	R471	18K	39K	39K
*5	UR402	50KB	100KB	50KB
*6	R428	3.3K	10K	6.8K
*7	C434	1/50	0.33/50	0.33/50
*8	R473	-	2.4K	-

	R-NO.	USA (E3)	EUROPE (E2)	MULTI ,CHINA
*9	J442	JUMPER	-	JUMPER
*10	T406	-	ANTI-BIRDIE	-
*11	C462	-	470P	-
*12	R472	-	100	-
*13	Q409	-	KTC3880	-
*14	R449	-	3.9K	-
*15	R450	-	1K	-
*16	R438 ,R439	100K	150K	100K

NOTICE

ALL RESISTANCE VALUES IN OHM. k=1,000 OHM M=1,000,000 OHM
 ALL CAPACITANCE VALUES IN MICRO FARAD. P=MICRO-MICRO FARAD
 EACH VOLTAGE AND CURRENT ARE MEASURED AT MO SIGNAL INPUT
 CONDITION.
 CIRCUIT AND PARTS ARE SUBJECT TO CHANGE WITHOUT PRIOR
 NOTICE.

WARNING:

Parts marked with this symbol  have
 Use ONLY replacement parts recommended.

CAUTION:

Before returning the unit to the customer
 (1) a leakage current check or (2) a line to chassis
 current exceeds 0.5 milliamps, or if the resistance
 of the power card is less than 460kohms.

WARNING:

DO NOT return the unit to the customer
 until corrected.

1 2
 PLL_CE
 PLL_DATA

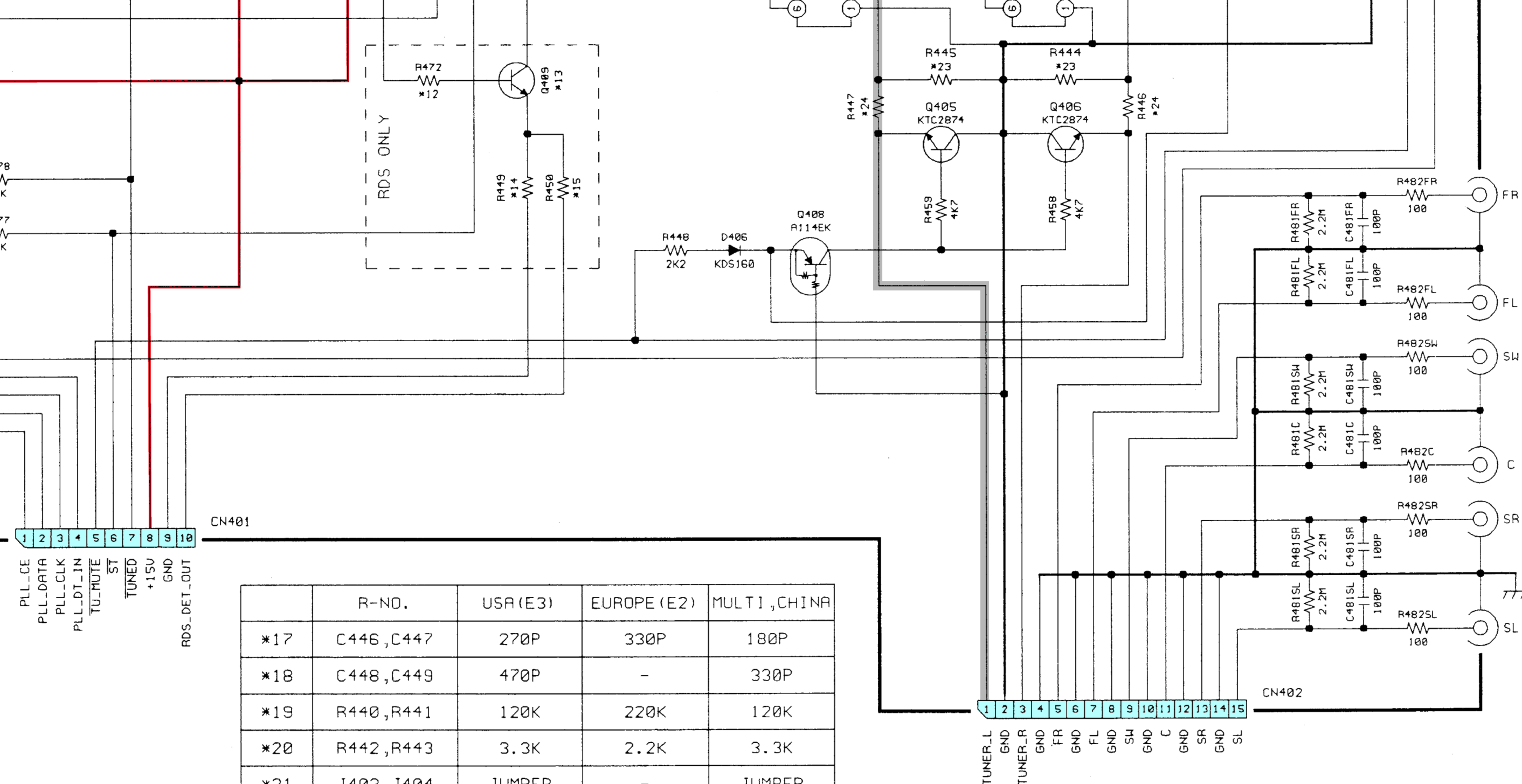

	R-NO.	USA (E3)	EUROPE (E2)	MULTI, CHINA
*17	C446, C447	270P	330P	180P
*18	C448, C449	470P	-	330P
*19	R440, R441	120K	220K	120K
*20	R442, R443	3.3K	2.2K	3.3K
*21	J403, J404	JUMPER	-	JUMPER
*22	T404, T405	-	LPF (MPX)	-
*23	R444, R445	8.2K	3.3K	8.2K
*24	R446, R447	JUMPER	470	JUMPER

— + B LINE
 SIGNAL LINE

have critical characteristics.
 recommended by the manufacture.

customer, make sure you make either (1) a
 e to chassis resistance check. If the leakage
 if the resistance from chassis to either side
 0kohms, the unit is defective.

customer until the problem is located and

SCHEMATIC DIAGRAMS(7/7) TUNER P.W.B. UNIT