

DENON

For U.S.A., Canada, Europe,
Asia, China, Hong Kong &
Taiwan R.O.C. model

Hi-Fi Component

SERVICE MANUAL

MODEL AVR-1602/682

AV SURROUND RECEIVER

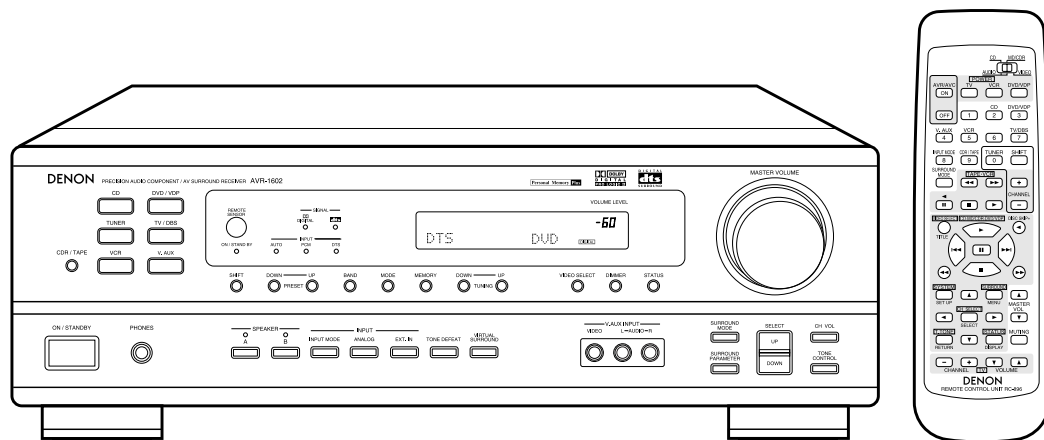

● Some illustrations using in this service manual are slightly different from the actual set.

NIPPON COLUMBIA CO., LTD.

14-14, AKASAKA 4-CHOME, MINATO-KU, TOKYO 107-8011 JAPAN
Telephone: 03 (3584) 8111

SAFETY PRECAUTIONS

The following check should be performed for the continued protection of the customer and service technician.

LEAKAGE CURRENT CHECK

Before returning the unit to the customer, make sure you make either (1) a leakage current check or (2) a line to chassis resistance check. If the leakage current exceeds 0.5 milliamps, or if the resistance from chassis to either side of the power cord is less than 460 kohms, the unit is defective.

SPECIFICATIONS

Audio Section

Power Amplifier

Rated output:	Front:	70W+70W	(8Ω/ohms, 20Hz~20kHz with 0.08% T.H.D)
		100W+100W	(6Ω/ohms, 1kHz with 0.7% T.H.D) (U.S.A., Canada & Europe Models)
		110W+110W	(6Ω/ohms, EIAJ) (Asia Model)
Center:		70W	(8Ω/ohms, 20Hz~20kHz with 0.08% T.H.D)
		100W	(6Ω/ohms, 1kHz with 0.7% T.H.D) (U.S.A., Canada & Europe Models)
		110W	(6Ω/ohms, EIAJ) (Asia Model)
Surround:		70W+70W	(8Ω/ohms, 20Hz~20kHz with 0.08% T.H.D)
		100W+100W	(6Ω/ohms, 1kHz with 0.7% T.H.D) (U.S.A., Canada & Europe Models)
		110W+110W	(6Ω/ohms, EIAJ) (Asia Model)
Output terminals:	Front:	A or B	6 to 16W/ohms
		A+B	12 to 16W/ohms
	Center/Surround:		6 to 16W/ohms

Analog

LINE input - PRE OUT

Input sensitivity/input impedance:	200mV/47kΩ/kohms
Frequency response:	10Hz~100kHz: +1, -3dB (TONE DEFEAT ON)
S/N ratio:	98dB (IHF-A weighted) (TONE DEFEAT ON)

Video Section

Standard video jacks

Input/output level and impedance:	1Vp-p, 75Ω/ohms
Frequency response:	5Hz~10MHz — +1, -3dB

S-video jacks (U.S.A., Canada & Asia Models)

Input/output level and impedance:	Y(brightness)signal — 1Vp-p, 75Ω/ohms
	C(color)signal — 0.286Vp-p, 75Ω/ohms
Frequency response:	5Hz~10MHz: — +1, -3dB

Tuner section

Receiving range:	[FM] (note: μV at 75Ω/ohms, 0dBf = 1×10 ⁻¹⁵ W)	[AM]	
	U.S.A., Canada Models:	87.50MHz~107.90MHz	520kHz~1710kHz
	Europe & Asia (for China) Models:	87.50MHz~108.00MHz	522kHz~1611kHz
	Asia (for Multiple voltage) Models:	87.50MHz~107.90MHz (0.2MHz steps)	520kHz~1710kHz (10kHz steps)
Usable sensitivity:	87.50MHz~108.00MHz (0.05MHz steps)	522kHz~1611kHz (9kHz steps)	
50 dB quieting sensitivity:	1.0μV (11.2dBf)	18μV	
S/N ratio:	MONO 1.6μV (15.3dBf)		
	STEREO 23μV (38.5dBf)		
Total harmonic distortion:	MONO 80dB (IHF-A weighted)		
	STEREO 75dB (IHF-A weighted)		
	MONO 0.15% (1kHz)		
	STEREO 0.3% (1kHz)		

General

Power supply:	U.S.A., Canada Models	AC120V,60Hz
	Europe Model	AC230V,50Hz
	Asia(for Multiple voltage)Model	AC115/230V,50/60Hz
	Asia(for China)Model	AC220V,50Hz
Power consumption:	3.7A (USA & Canada model), 200W (Europe & Asia model)	
Maximum external dimensions:	434 (W) × 147 (H) × 417 (D) mm (17-3/32" × 5-25/32" × 16-7/16")	
Mass:	9.8kg (20 lbs 9.7 oz)	

Remote control unit (RC-896)

Batteries:	R6P/AA Type (two batteries)
External dimensions:	54 (W) × 172.5 (H) × 29 (D) mm (2-1/8" × 6-51/64" × 1-9/64")
Mass:	120g (Approx. 4.2 oz) (including batteries)

* For purposes of improvement, specifications and design are subject to change without notice.

DISASSEMBLY

(Follow the procedure below in reverse order when reassembling)

Top Cover

Remove 6 screws ① and 3 screws ②, detach the Top Cover in the arrow direction.

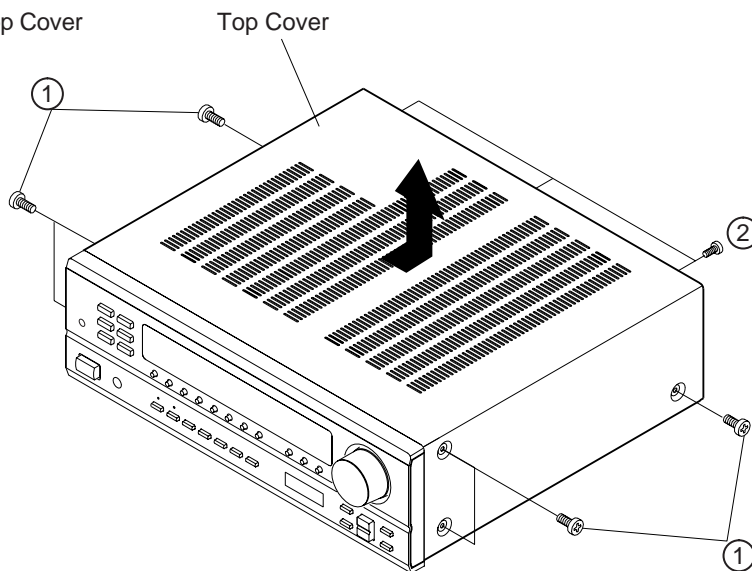

Front Panel

1. Remove 4 screws ③ and 2 screws ④.
2. Detach the Front Panel in the arrow direction.

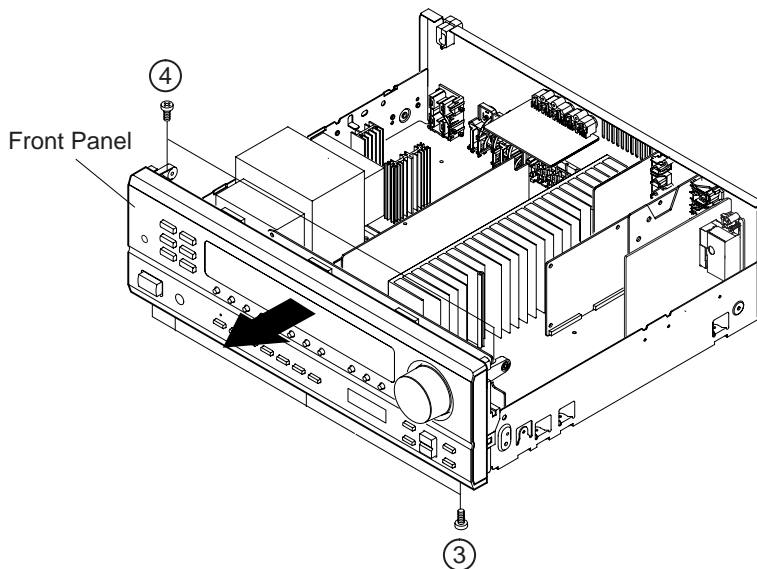

Rear Panel

1. Remove cord bushing ⑤ from the Rear Panel.
2. Remove 31 screws ⑥.
3. Detach the Rear Panel in the arrow direction.

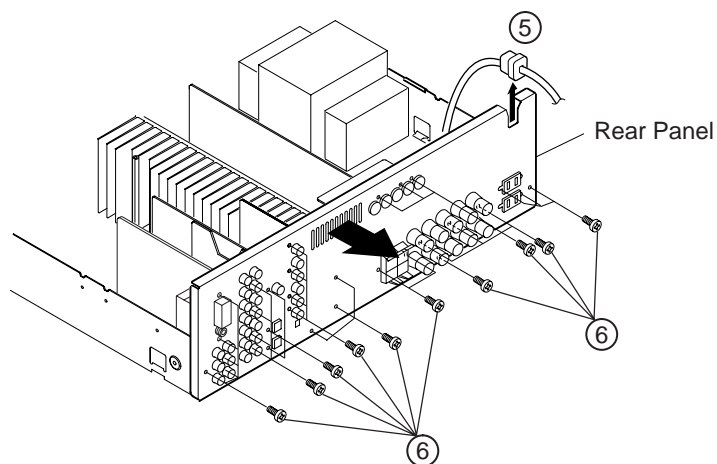

LEVEL DIAGRAM

1 2 3 4 5 6 7 8

LEVEL DIAGRAM

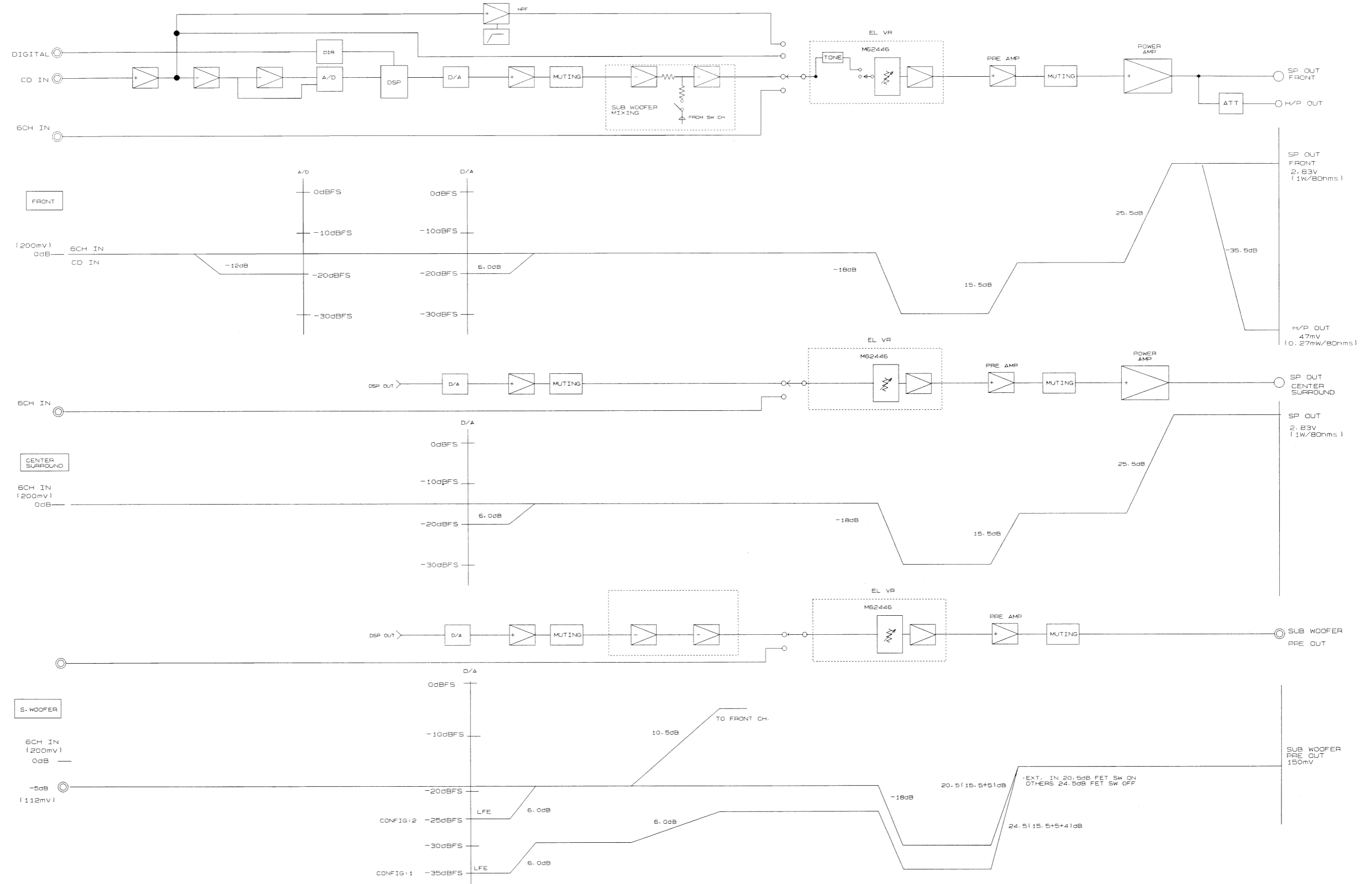

A
B
C
D
E

BLOCK DIAGRAM

1 2 3 4 5 6 7 8

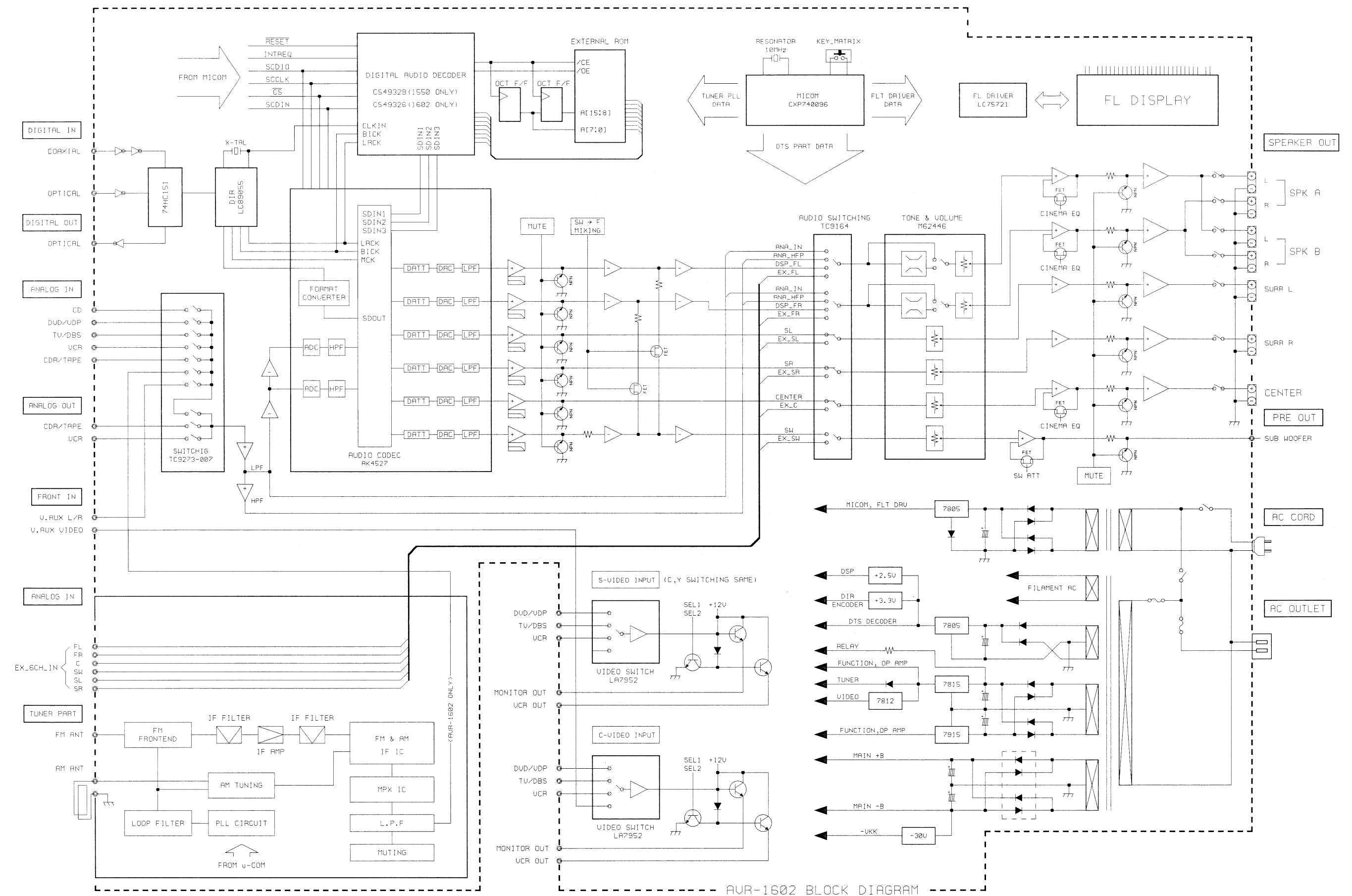

AVR-1602 BLOCK DIAGRAM

A
B
C
D
E

ADJUSTMENT

Tuner Section

CONNECTION DIAGRAM OF MEASURING INSTRUMENTS

● FM

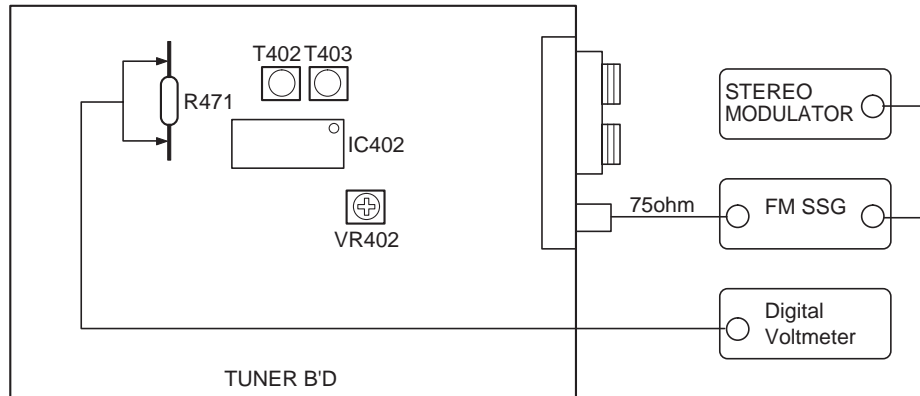

FM ALIGNMENT

Step	Alignment Item	Tuning Frequency Setting	Input					Output		Adjustment	
			Type	Frequency	Input Level	Modulation	Coupling	Type	Connect to	Points	Adjust to
1	Center Adjustment	98.1MHz (98.0MHz)	FM SSG	98.1MHz	60dB μ	Mono 1kHz 100%	Antenna Terminal	Digital Voltmeter	R471	T402	$\pm 50mV$
2	Distortion	98.1MHz (98.0MHz)	FM SSG	98.1MHz	60dB μ	Mono 1kHz 100%	Antenna Terminal	Distortion Meter	Output Terminal (L)	T403	Minimum Distortion
3	Repeat Steps 1 and 2										
4	Signal Level	98.1MHz (98.0MHz)	FM SSG	98.1MHz	20dB μ	OFF	Antenna Terminal	Light "TUNED" on FL Display	VR402		20^{+14}_{-10} dB

● AM

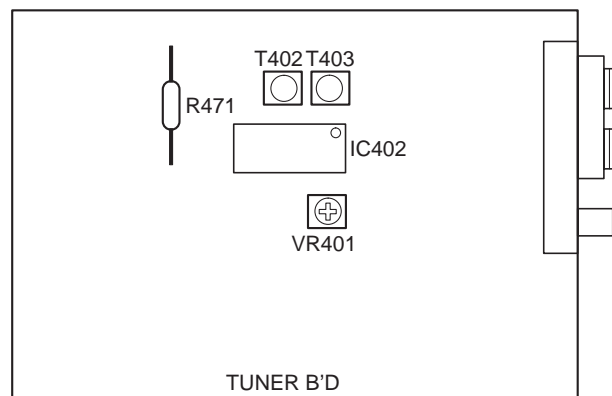

AM ALIGNMENT

Step	Alignment Item	Frequency	Input	Output		Adjustment		Remarks
				Type	Connect to	Points	Adjust to	
1	Signal Level	999 (1000) kHz	AM SSG	—	—	VR401	Light "TUNED" on FL Display	SSG OUTPUT 74dB μ (EMF)

Audio Section

Idling Current

Required measurement equipment : DC Voltmeter

Preparation

- (1) Avoid direct blow from an air conditioner or an electric fan, and adjust the unit at normal room temperature 15 °C ~ 30 °C (59 °F ~ 86 °F).
- (2) Presetting
 - POWER (Power source switch) → OFF
 - SPEAKER (Speaker terminal) → No load (Do not connect speaker, dummy resistor, etc.)

Adjustment

- (1) Remove top cover and set VR101, VR102, VR103, VR104, VR105 on Amp. Unit at full counterclockwise (⚙) position.
- (2) Connect DC Voltmeter to test points (FRONT-Lch: TP104, FRONT-Rch: TP105, CENTER ch: TP103, SURROUND-Lch: TP101, SURROUND-Rch: TP102).
- (3) Connect power cord to AC Line, and turn power switch "ON".
- (4) Presetting.

MASTER VOLUME	: "---	counterclockwise (⚙ min.)
MODE	: 5CH STEREO	
FUNCTION	: CD	
- (5) Within 2 minutes after the power on, turn VR101 clockwise (⚙) to adjust the TEST POINT voltage to 1.5 mV \pm 0.5 mV DC.
- (6) After 10 minutes from the preset above, turn VR101 to set the voltage to 2.5 mV \pm 0.5 mV DC.
- (7) Adjust the Variable Resistors of other channels in the same way.

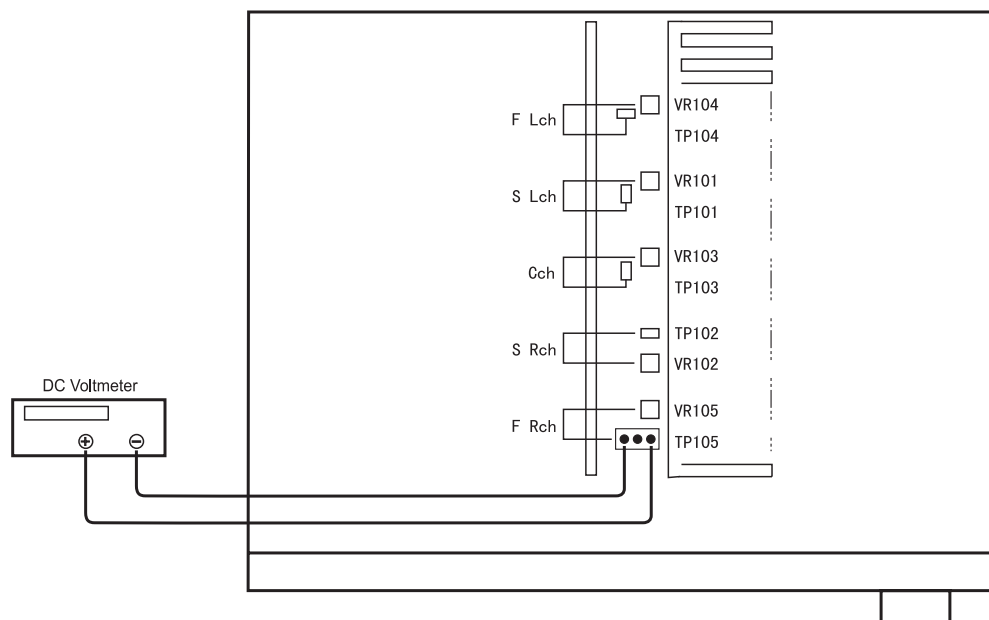

SEMICONDUCTORS

● IC's
CS49326-CL
(IC812)

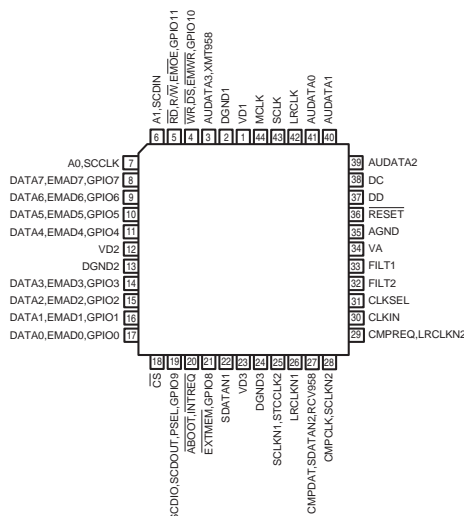

CS49326-CL Terminal Function

Pin No.	Pin Name	Function
1	VD1	Digital positive supply
2	DGND1	Digital supply ground
3	AUDATA3, XMT958	SPDIF transmitter output, Digital audio output 3
4	WR, DS, EMWR, GPIO10	Host write strobe or host data strobe or external memory write enable or general purpose input & output number 10
5	RD, R/W, EMOE, GPIO11	Host parallel output enable or host parallel R/W or external memory output enable or general purpose input & output number11
6	A1, SCDIN	Host address bit one or SPI serial control data input
7	A0, SCCLK	Host parallel address bit zero or serial control port clock
8	DATA7, EMAD7, GPIO7	
9	DATA6, EMAD6, GPIO6	
10	DATA5, EMAD5, GPIO5	
11	DATA4, EMAD4, GPIO4	
12	VD2	Digital positive supply
13	DGND2	Digital supply ground
14	DATA3, EMAD3, GPIO3	
15	DATA2, EMAD2, GPIO2	
16	DATA1, EMAD1, GPIO1	
17	DATA0, EMAD0, GPIO0	
18	CS	Host parallel chip select, host serial SPI chip select
19	SCDIO, SCDOUT, PSEL, GPIO9	Serial control port data input and output, parallel port type select
20	INTREQ, ABOOT	Control port interrupt request, automatic boot enable
21	EXTMEM, GPIO8	External memory chip select or general purpose input & output number 8
22	SDATAN1	PCM audio data input number one
23	VD3	Digital positive supply
24	DGND3	Digital supply ground
25	SCLKN1, STCCLK2	PCM audio input bit clock
26	LRCLKN1	PCM audio input sample rate clock
27	CMPDAT, SDATAN2, RCV958	PCM audio data input number two
28	CMPCLK, SCLKN2	PCM audio input bit clock
29	CMPREQ, LRCLKN2	PCM audio input sample rate clock
30	CLKIN	Master clock input
31	CLKSEL	DSP clock select
32	FILT2	Phase locked loop filter
33	FILT1	Phase locked loop filter
34	VA	Analog positive supply
35	AGND	Analog supply ground
36	RESET	Master reset input
37	DD	Reserved
38	DC	Reserved
39	AUDATA2	Digital audio output 2
40	AUDATA1	Digital audio output 1
41	AUDATA0	Digital audio output 0
42	LRCLK	Audio output sample rate clock
43	SCLK	Audio output bit clock
44	MCLK	Audio master clock

LC89055W (IC810)

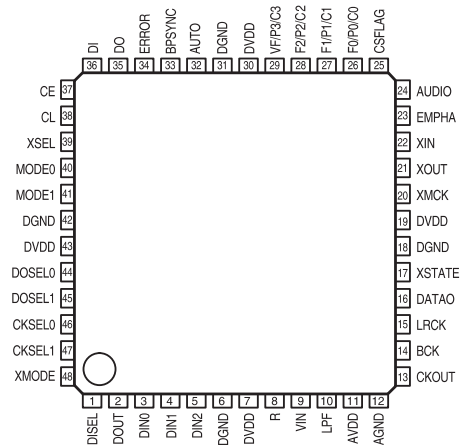

LC89055W Terminal Function

Pin No.	Pin Name	I/O	Function
1	DISEL	I	Data input terminal (select input pin of DIN0, DIN1)
2	DOUT	O	Input bi-phase data through output terminal
3	DIN0	I	Amp built-in coaxial/optical input correspond data input terminal
4	DIN1	I	Amp built-in coaxial/optical input correspond data input terminal
5	DIN2	I	Optical input correspond data input terminal
6	DGND		Digital GND
7	DVDD		Digital power supply
8	R	I	VCO gain control input terminal
9	VIN	I	VCO free-run frequency setting input terminal
10	LPF	O	PLL loop filter setting terminal
11	AVDD		Analog power supply
12	AGND		Analog GND
13	CKOUT	O	Clock output terminal (256fs, 384fs, 512fs, X'tal osc., VCO free-run osc.)
14	BCK	O	64fs clock output terminal
15	LRCK	O	fs clock output terminal (L: Rch, H: Lch, I ² S: Reverse)
16	DATAO	O	Data output terminal
17	XSTATE	O	Input data detecting result output terminal
18	DGND		Digital GND
19	DVDD		Digital power supply
20	XMCK	O	X'tal osc. clock output terminal (24.576MHz or 12.288MHz)
21	XOUT	O	X'tal osc. connection output terminal
22	XIN	I	X'tal osc. connection input terminal, external signal input possible (24.576MHz or 12.288MHz)
23	EMPHA	O	Emphasis information output terminal of channel status
24	AUDIO	O	Bit1 output terminal of channel status
25	CSFLAG	O	Top 40bit revise flag output terminal of channel status
26	F0/P0/C0	O	Input fs cal. sig. out/data type out/input word inf. output terminal
27	F1/P1/C1	O	Input fs cal. sig. out/data type out/input word inf. output terminal
28	F2/P2/C2	O	Input fs cal. sig. out/data type out/input word inf. output terminal
29	VF/P3/C3	O	Validity flag out/data type out/input word inf. output terminal
30	DVDD		Digital power supply
31	DGND		Digital GND
32	AUTO	O	Non PCM burst data transfer detect sig. output terminal
33	BPSYNC	O	Non PCM burst data preamble Pa, Pb, Pc, Pd sync sig. output terminal
34	ERROR	O	PLL lock error, data error flag output terminal
35	DO	O	CPU/IFD read data output terminal
36	DI	I	CPU I/F write data input terminal
37	CE	I	CPU I/F chip enable input terminal
38	CL	I	CPU I/F chip enable input terminal
39	XSEL	I	Frequency select input pin of XIN X'tal osc. (24.576MHz or 12.288MHz)
40	MODE0	I	Mode setting input terminal
41	MODE1	I	Mode setting input terminal
42	DGND		Digital GND
43	DVDD		Digital power supply
44	DOSEL0	I	Data output format select input terminal
45	DOSEL1	I	Data output format select input terminal
46	CKSEL0	I	Output clock select input terminal
47	CKSEL1	I	Output clock select input terminal
48	XMODE	I	Reset input terminal

- For latch-up countermeasure, set digital (DVDD) and analog (AVDD) power on/off in the same timing.

AK4527BVQ (IC813)

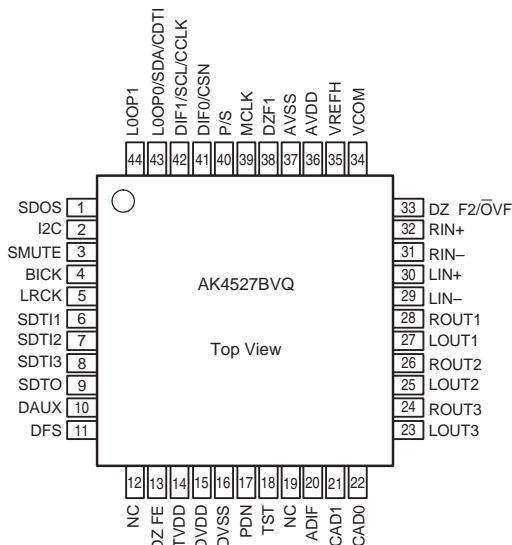

AK4527BVQ Terminal Function

Pin No.	Pin Name	I/O	Function
1	SDOS	I	SDTO source select pin, L: Internal ADC output, H: DAUX input
2	I2C	I	Serial control mode select pin, L: 3-core serial, H: I ² C bus
3	SMUTE	I	Soft mute pin, H: Soft mute start, L: Release
4	BICK	I	Audio serial data clock pin
5	LRCK	I	Input channel clock pin
6	SDT11	I	DAC1 audio serial data input pin
7	SDT12	I	DAC2 audio serial data input pin
8	SDT13	I	DAC3 audio serial data input pin
9	SDTO	O	Audio serial data output pin
10	DAUX	I	Auxiliary audio serial data input pin
11	DFS	I	Double speed sampling mode pin, L: Normal, H: Double
12	NC	—	No Connect, No internal bonding
13	DZFE	I	Zero input detect enable pin
14	TVDD	—	Power pin for output buffer, 2.7V~5.5V
15	DVDD	—	Digital power pin, 4.5V~5.5V
16	DVSS	—	Digital GND pin, 0V
17	PDN	I	Power down & reset pin, L: Powered-down and register initialized, Reset with PDN when switching P/S or CAD0-1
18	TST	I	Test pin, connected to DVSS
19	NC	—	No Connect, No internal bonding
20	ADIF	I	Analog Input Format Select pin
21	CAD1	I	Chip address-1 pin
22	CAD0	I	Chip address-0 pin
23	LOUT3	O	DAC3L channel analog out pin
24	ROUT3	O	DAC3R channel analog out pin
25	LOUT2	O	DAC2L channel analog out pin
26	ROUT2	O	DAC2R channel analog out pin
27	LOUT1	O	DAC1L channel analog out pin
28	ROUT1	O	DAC1R channel analog out pin
29	LIN-	I	L-ch analog inverted input pin
30	LIN+	I	L-ch analog non-inverted input pin
31	RIN-	I	R-ch analog inverted input pin
32	RIN+	I	R-ch analog non-inverted input pin
33	DZF2/OVF	O	0 input detect 2 pin/Analog input overflow detect pin
34	VCOM	O	Common V-out pin, AVDD/2, connect large capacitor to avoid noise
35	VREFH	I	Ref. V input pin, AVDD
36	AVDD	—	Analog GND pin, 4.5V~5.5V
37	AVSS	—	Analog GND pin, 0V
38	DZF1	O	0 input detect pin, H: Input data of G1 is 8192 times "0" in a raw or RSTN bit "0"
39	MCLK	I	Master clock input pin
40	P/S	I	Parallel/Serial select pin, L: Serial control
41	DIF0	I	Audio data I/F format 0 pin (parallel control)
	CSN	I	Chip select pin (3-wire serial control), connect to DVDD when I ² C bus control
	DIF1	I	Audio data I/F format 1 pin (parallel control)
42	SCL/CCLK	I	Control data clock pin (serial control), I ² C="L": CCLK (3-wire serial), I ² C="H": SCL (I ² C bus)
43	LOOP0	I	Loop back mode 0 pin (parallel control), effects digital loop back ADC to all DAC
	SDA/CDTI	I/O	Control data input pin (serial control), I ² C="L": CCT1 (3-wire serial), I ² C="H": SDA (I ² C bus)
44	LOOP1	I	Loop back mode 1 pin, from SDT1 to all DAC

LC72131 (IC401)

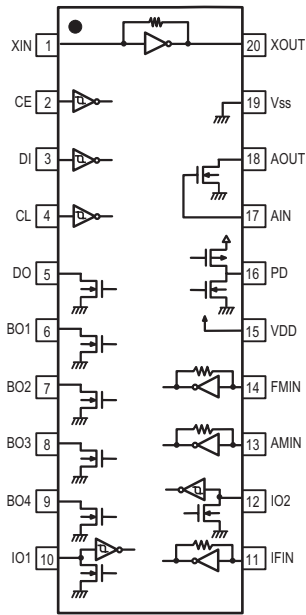

LA1266 (IC402)

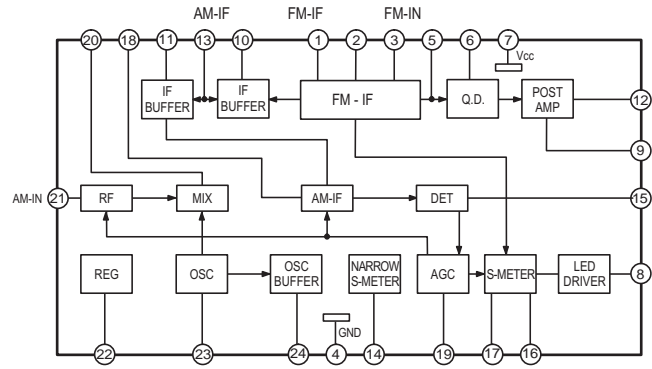
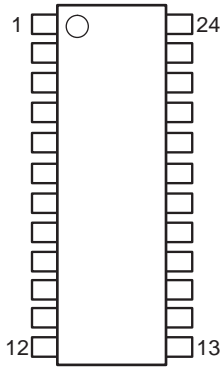

LA3401 (IC403)

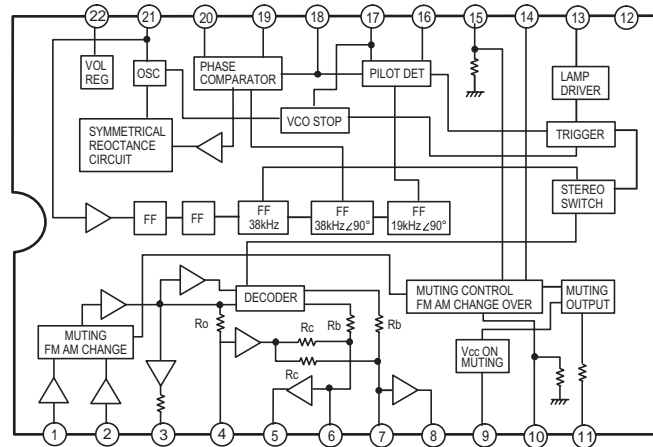

BU2090F (IC302)

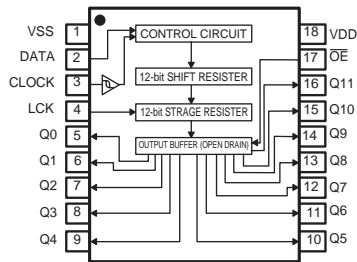

TDA7330BD (IC202)

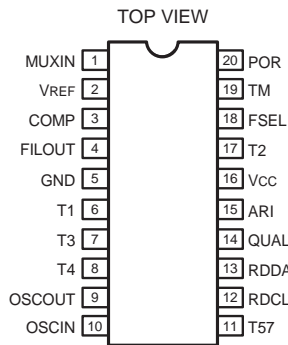

MM74LCX244 (IC818,819)

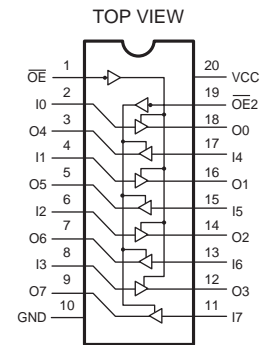

MM74HC151 (IC832)

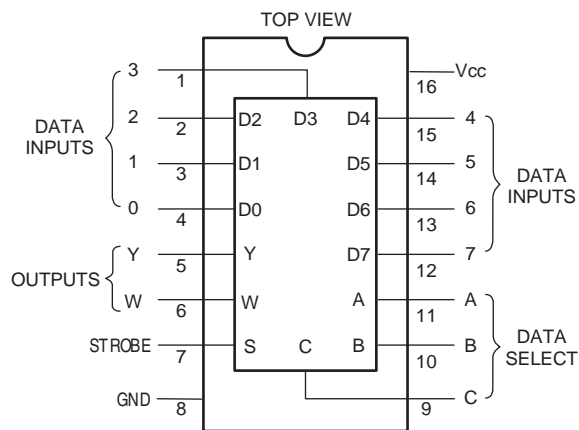

**RC1117S25T (IC820)
RC1117S33ST (IC811)**

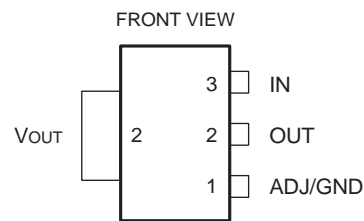

LC75721E (IC301)

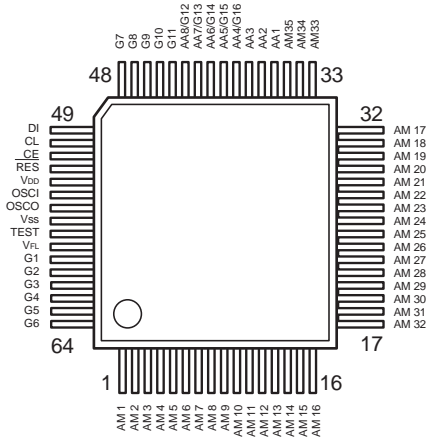

● LC75721E Terminal Function

Symbol	Function
V _{DD}	Power terminal +5V
V _{SS}	Power terminal GND
V _{FL}	Power terminal FL drive
DI	Serial data transfer terminal
CL	DI: Data
CE	CL: Clock
	CE: Chip enable
OSCI	External CR connecting terminal
OSCO	
RES	System reset terminal
AM1-AM35	Anode output terminal
AA1-AA3	
AA4/G16 AA5/G15 AA6/G14 AA7/G13 AA8/G12	
G1-G11	Grid output terminal
TEST	LSI test terminal

KIC9164AN (IC221)

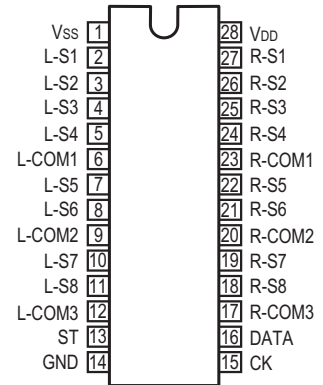

TC9273N-007(IC701)

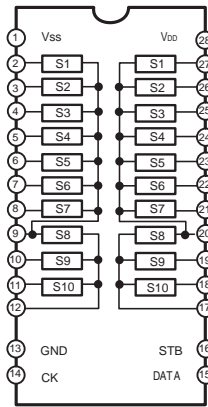

● TC9273N Terminal Function

Pin No.	Symbol	Name	Function	
1	V _{SS}	+ Power Terminal	Dual Power Use: V _{DD} =8.0~17V	Single Power Use: V _{DD} =8.0~18V
13	GND	Digital Ground	GND=0V	
28	V _{DD}	+ Power Terminal	V _{SS} =-8.0~-17V	
2-12 12-27	S1-S10	I/O Terminal	Input terminal of analog switch.	
14	CK	Clock Input	Clock input for data transfer.	
15	DATA	Data Input	Serial input for switch setting.	
16	STB	Strobe Input	Strobe Input Strobe input for data writing.	
				Low level Border Input Terminal

W27W201 (IC807)

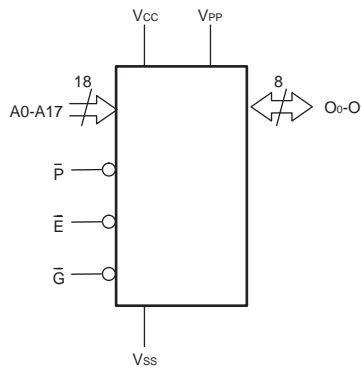
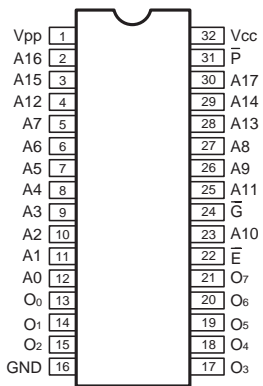

NJM2068DD
(IC241,251,261,271,281,291,702,703)
BA4510F (IC805~806)
NJM2068MD (IC814~816)

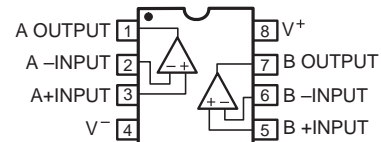

SN74LV00APW (IC822)

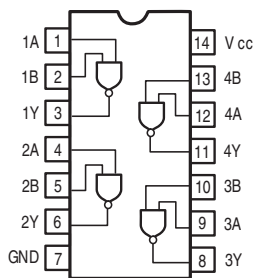

74HCU04 (IC803)

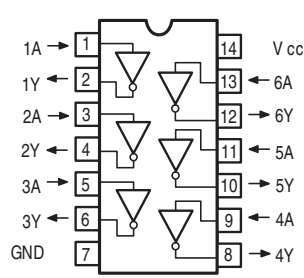

LA7952 (IC601,651,652)

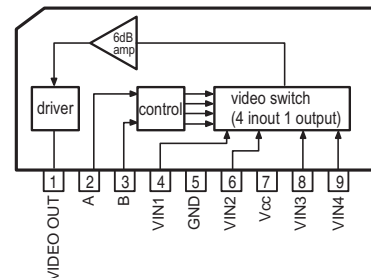

SN74LV4040 (IC831)

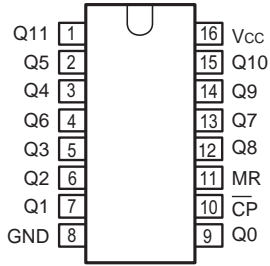

Terminal Function

INPUTS		OUTPUTS
CP	MR	Qn
↑	L	no change
↓	L	count
X	H	L

H=HIGH voltage level
 L=LOW voltage level
 X=don't care
 ↑=LOW-to-HIGH clock transition
 ↓=HIGH-to-LOW clock transition

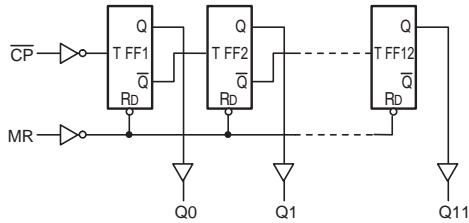

M62446FP (IC231)

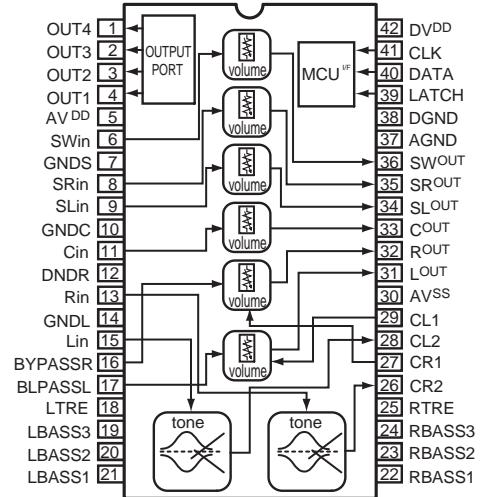

KIA7805AP (IC104)

KIA7815AP (IC101)

NJM7805FA (IC103,829)

NJM7812FA (IC602)

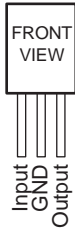

NJM7915FA (IC102)

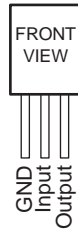

MM74LCX574 (IC808,809)

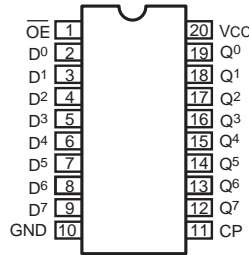

MM74HCT244 (IC828,830)

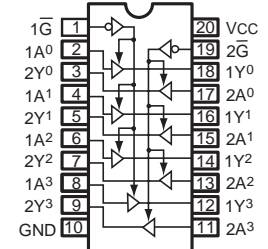

● **OPTICAL**

INPUT GP1FA502RZ (IC802)

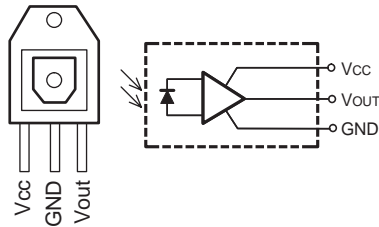

OUTPUT GP1FA502TZ (IC817)

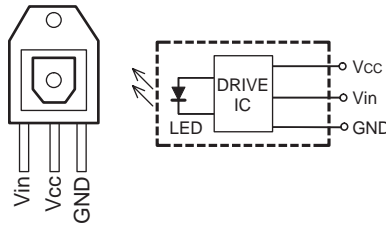

● **IC PROTECTOR**

ICP-N15 (IC105)

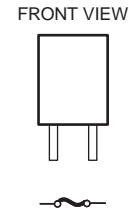

● **IR SENSOR**

NJL64H380A(RMC301)

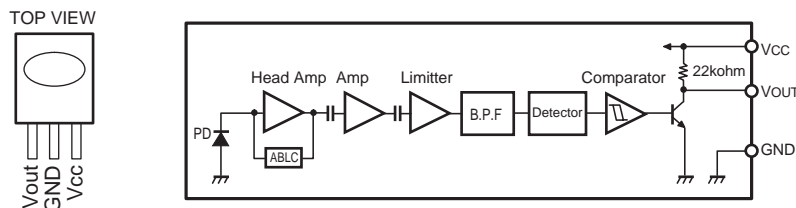

● **POSISTOR**

P43T7D330BW16

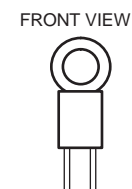

● TRANSISTORS

DTA114ES
DTC114TS
DTC114YS
DTC144ES



DTA114EK
DTA114YK
DTA144EK
DTC114EK
DTC114YK
DTC144EK

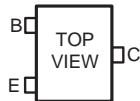

DTA Series

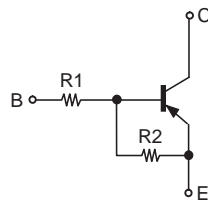

	R1	R2
DTA114EK	10kohm / Ω	10kohm / Ω
DTA114ES	10kohm / Ω	10kohm / Ω
DTA114YK	10kohm / Ω	47kohm / Ω
DTA144EK	47kohm / Ω	47kohm / Ω

DTC Series

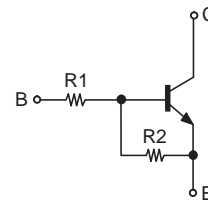

	R1	R2
DTC114EK	10kohm / Ω	10kohm / Ω
DTC114TS	10kohm / Ω	—
DTC114YK	10kohm / Ω	47kohm / Ω
DTC114YS	10kohm / Ω	47kohm / Ω
DTC144EK	47kohm / Ω	47kohm / Ω
DTC144ES	47kohm / Ω	47kohm / Ω

2SC1740S
2SC3199Y
KSA916Y
KSA992F
KSC1845F
KTA1266Y
KTA1268BL
KTC2874B
KTC3198Y
KTC3200BL



2SC2412K
KTC3880S

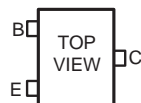

2SK117



● DIODES (LED included)

MTZJ3.3B
MTZJ5.1B
MTZJ5.6B
MTZJ6.8B
MTZJ7.5A
MTZJ7.5B
MTZJ11B
MTZJ18B
MTZJ20B

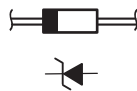

1N4007
1SS133

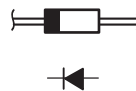

KDS160



HL-50RDRF4T



KBPC604

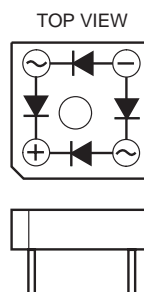

● FL DISPLAY

16-st-42GNK (FL301)

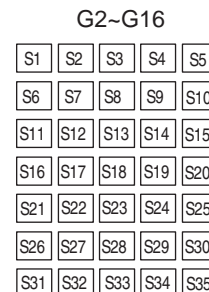
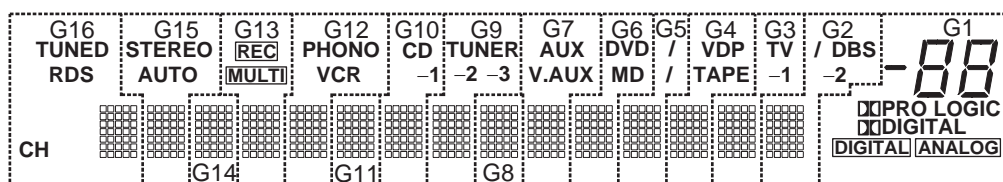
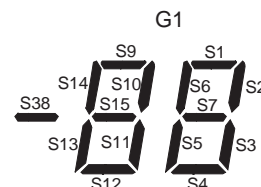
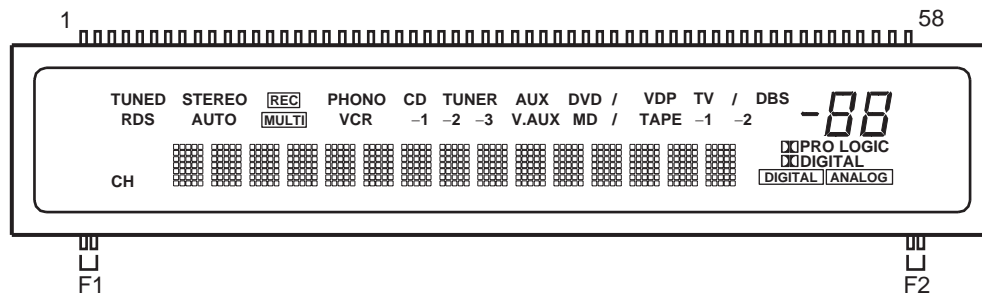

Pin Assignment

PIN NO.	1	2	3	4	5	6	7	8	9	10	11	12	13	14	15	16	17	18	19	20
CONNECTION	F1	F1	S1	S2	S3	S4	S5	S6	S7	S8	S9	S10	S11	S12	S13	S14	S15	S16	S17	S18
PIN NO.	21	22	23	24	25	26	27	28	29	30	31	32	33	34	35	36	37	38	39	40
CONNECTION	S19	S20	S21	S22	S23	S24	S25	S26	S27	S28	S29	S30	S31	S32	S33	S34	S35	S36	S37	S38
PIN NO.	41	42	43	44	45	46	47	48	49	50	51	52	53	54	55	56	57	58		
CONNECTION	G16	G15	G14	G13	G12	G11	G10	G9	G8	G7	G6	G5	G4	G3	G2	G1	F2	F2		

F1, F2 : Filament
 G1~G16: Grid
 S1~S38 : Anode

Anode & Grid Assignment

	G1	G2~G16		G1	G2~G16		G1	G2~G16		G1	G2~G16
S1	S1	S1	S10	S10	S10	S19	—	S19	S28	—	S28
S2	S2	S2	S11	S11	S11	S20	—	S20	S29	—	S29
S3	S3	S3	S12	S12	S12	S21	—	S21	S30	—	S30
S4	S4	S4	S13	S13	S13	S22	—	S22	S31	—	S31
S5	S5	S5	S14	S14	S14	S23	—	S23	S32	—	S32
S6	S6	S6	S15	S15	S15	S24	—	S24	S33	—	S33
S7	S7	S7	S16	—	S16	S25	—	S25	S34	—	S34
S8	—	S8	S17	DIGITAL	S17	S26	—	S26	S35	—	S35
S9	S9	S9	S18	PRO LOGIC	S18	S27	—	S27			

	G1	G2	G3	G4	G5	G6	G7	G8	G9	G10	G11	G12	G13	G14	G15	G16
S36	DIGITAL	/	TV	VDP	/(DVD)	DVD	AUX	—	TUNER	CD	—	PHONO	REC	—	STEREO	TUNED
S37	ANALOG	-2	-1	TAPE	/(MD)	MD	V.AUX	—	-2	-1	—	VCR	MULTI	—	AUTO	RDS
S38	S38	DBS	—	—	—	—	—	—	-3	—	—	—	—	—	—	CH

PRINTED WIRING BOARDS

1 2 3 4 5 6 7 8

MAIN P.W.B. UNIT Ass'y

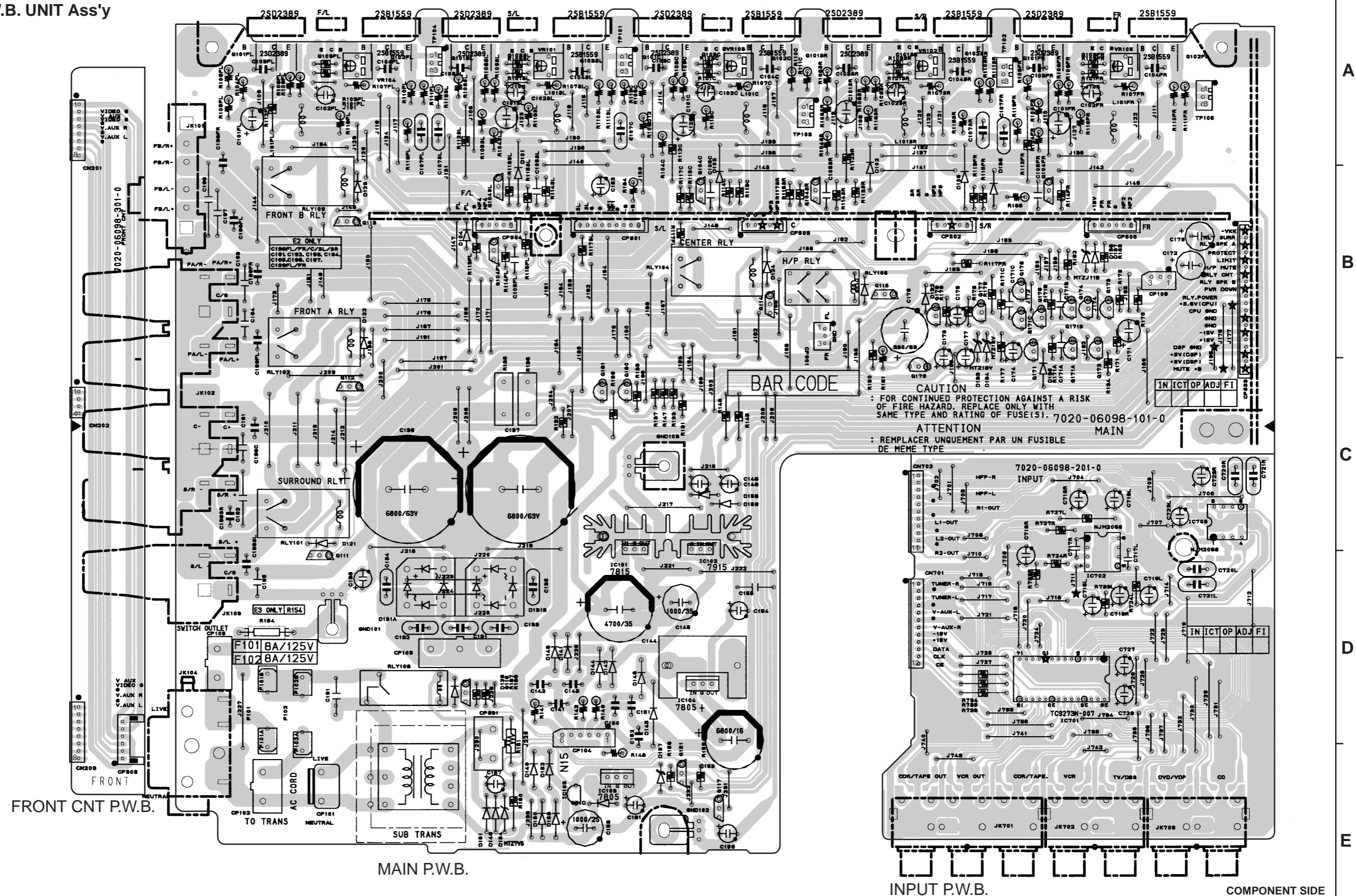

FRONT CNT P.W.B.

MAIN P.W.B.

INPUT P.W.B.

COMPONENT SIDE

A
B
C
D
E

1 2 3 4 5 6 7 8

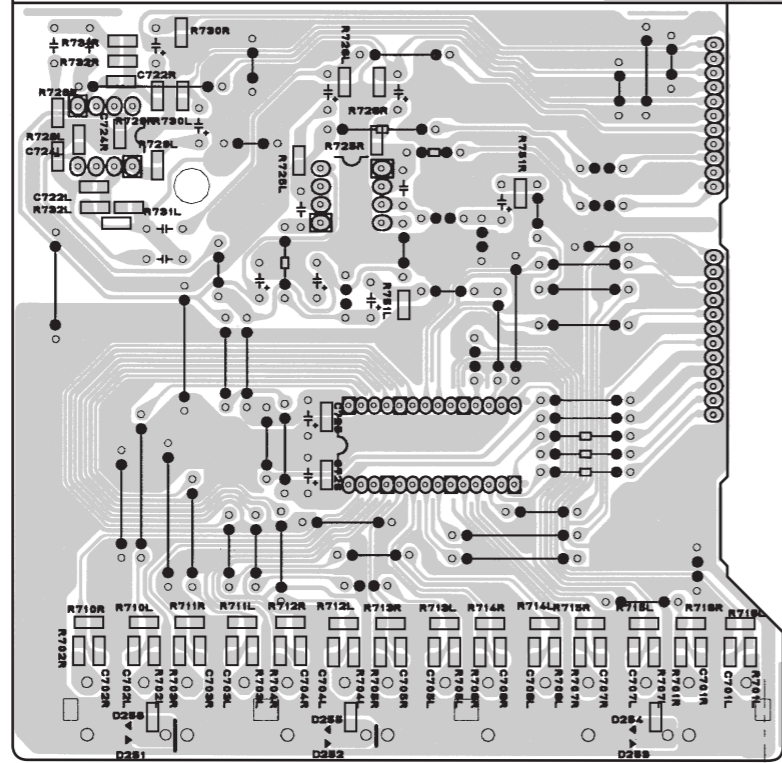
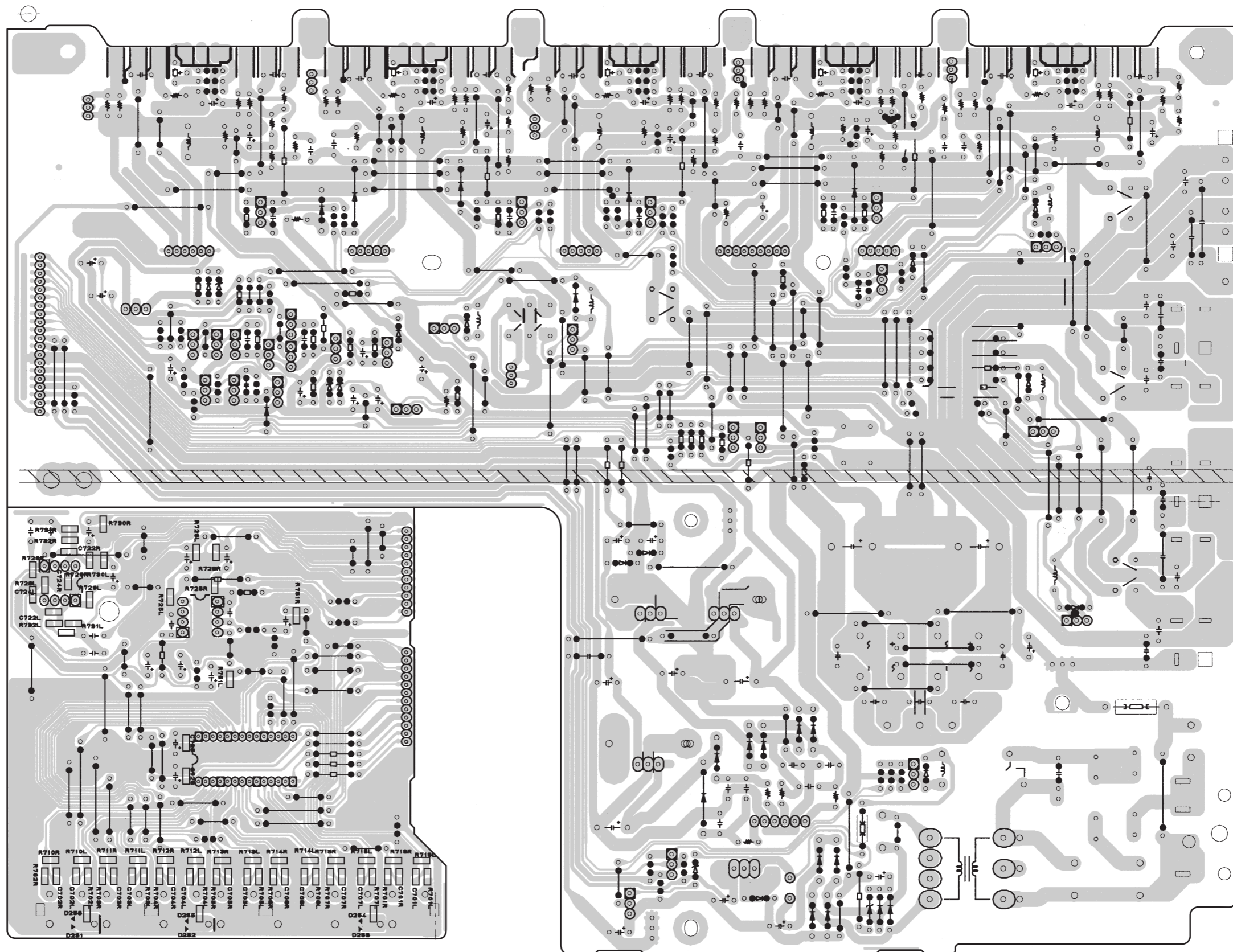

INPUT P.W.B.

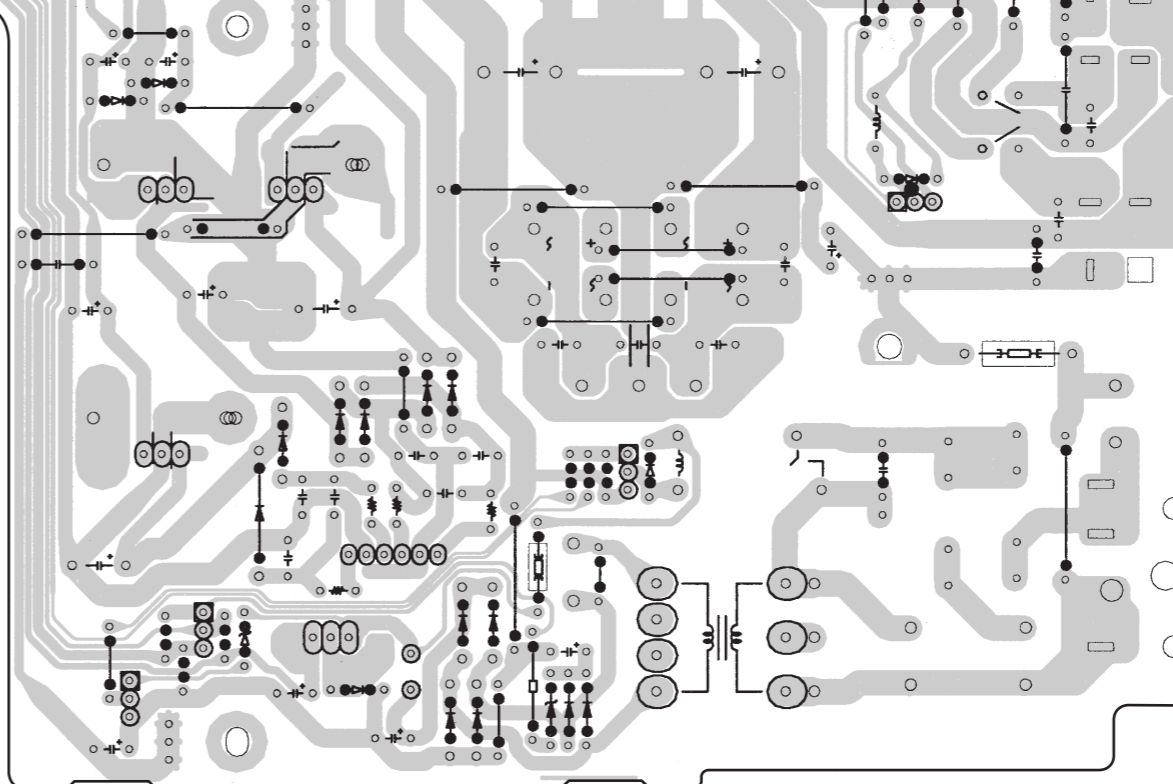

MAIN P.W.B.

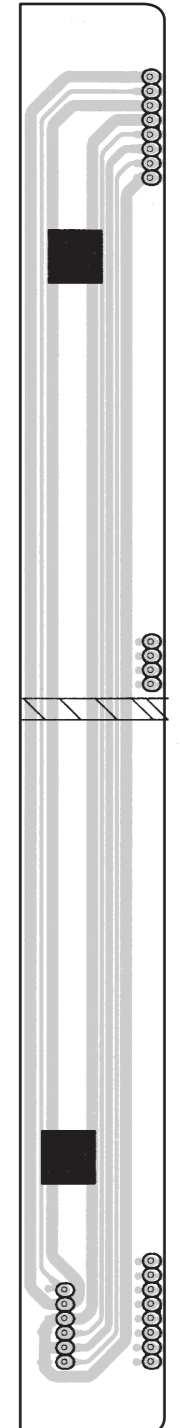

FRONT CNT P.W.B.

A
B
C
D
E

FOIL SIDE

1 2 3 4 5 6 7 8

CPU P.W.B. UNIT Ass'y

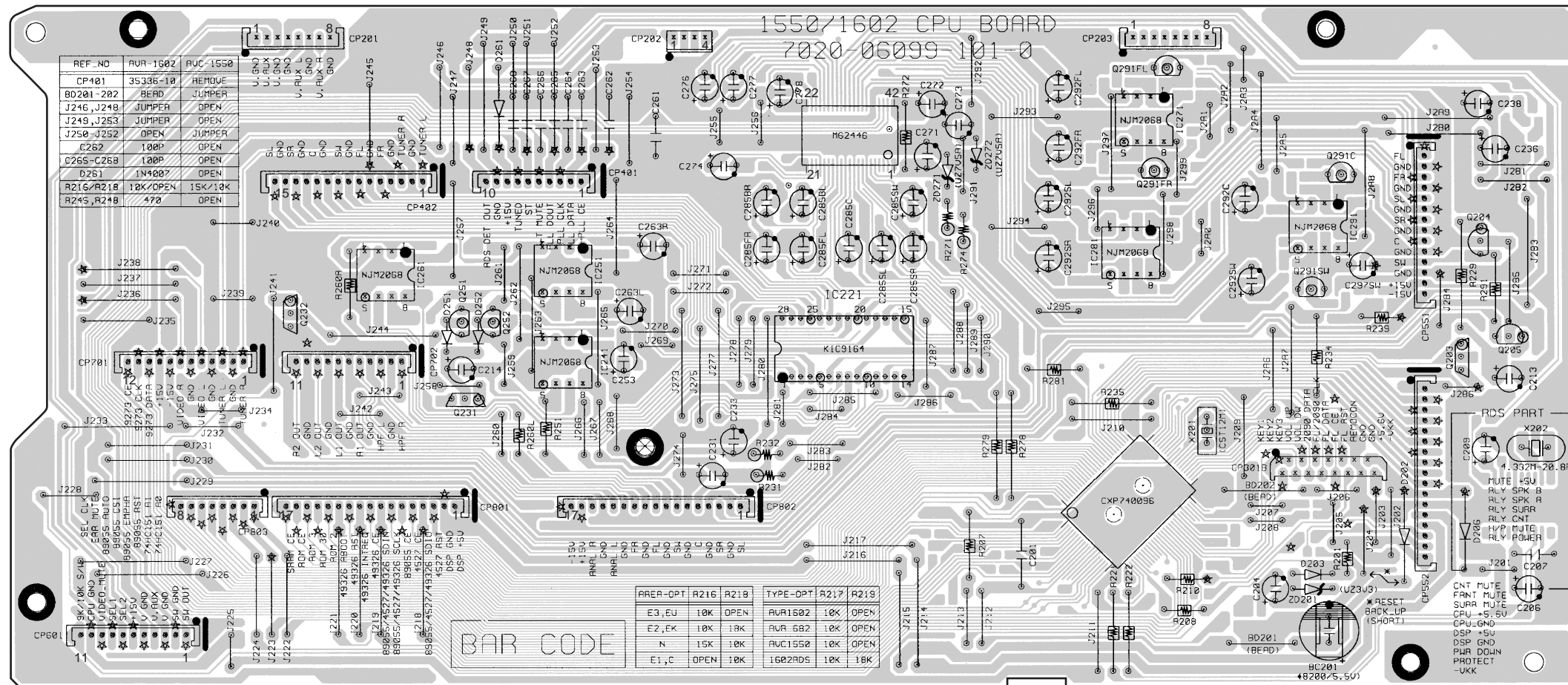

CPU P.W.B

AC OUTLET P.W.B (E2 ONLY)

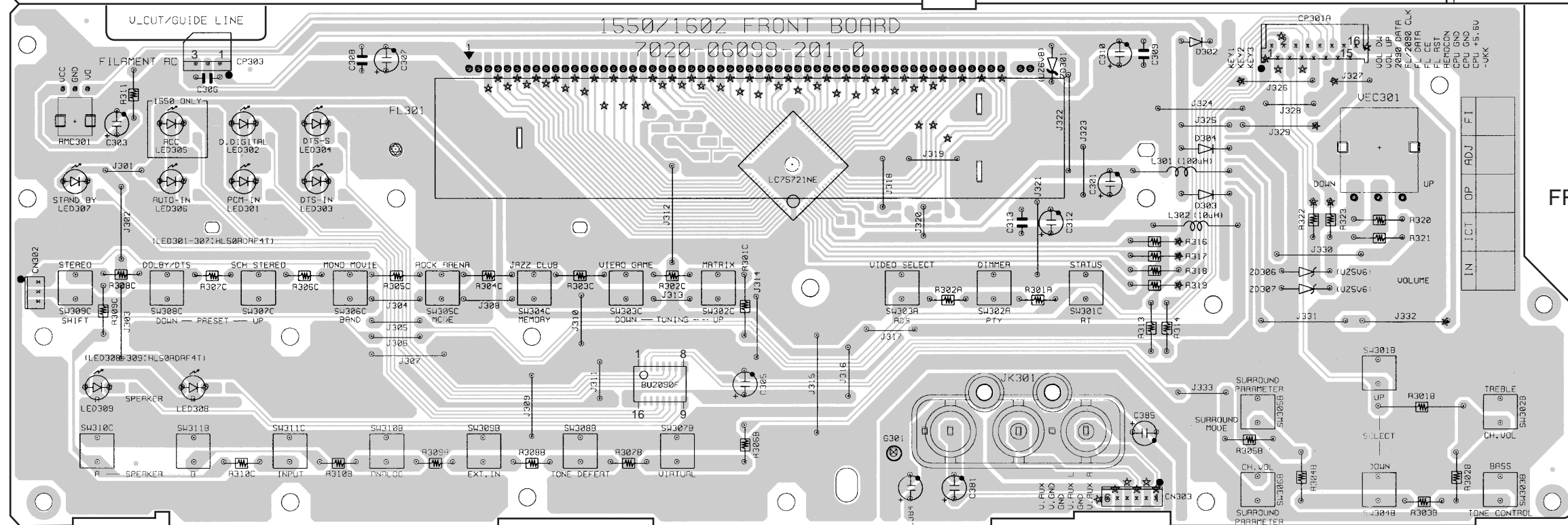
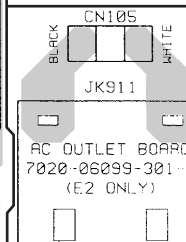

FRONT P.W.B

COMPONENT SIDE

A
B
C
D
E

1 2 3 4 5 6 7 8

CPU P.W.B

AC OUTLET P.W.B
(E2 ONLY)

AC OUTLET BOARD
7070-0E299-301-0
(E2 ONLY)

FRONT P.W.B

AREA-OP1	R216	R218	TAPE-OP1	R217	R219
E3,EU	10K	OPEN	AVR1602	10K	OPEN
E2,EK	10K	10K	AVR 682	10K	OPEN
N	15K	10K	AVC1550	10K	OPEN
E1,C	OPEN	10K	1602PDS	10K	10K

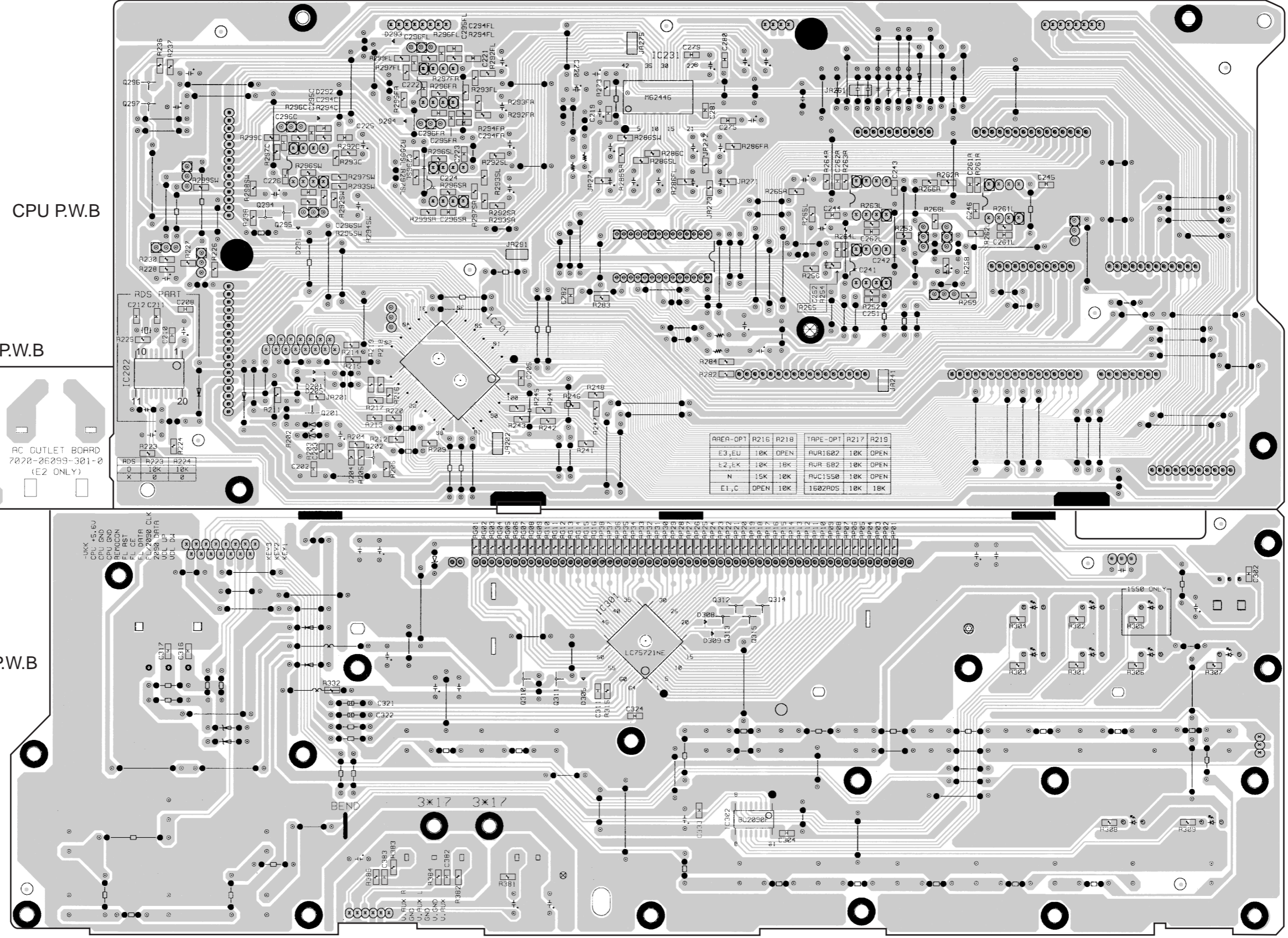

A
B
C
D
E

FOIL SIDE

1 2 3 4 5 6 7 8

CONNECTION P.W.B. UNIT Ass'y

TUNER P.W.B.

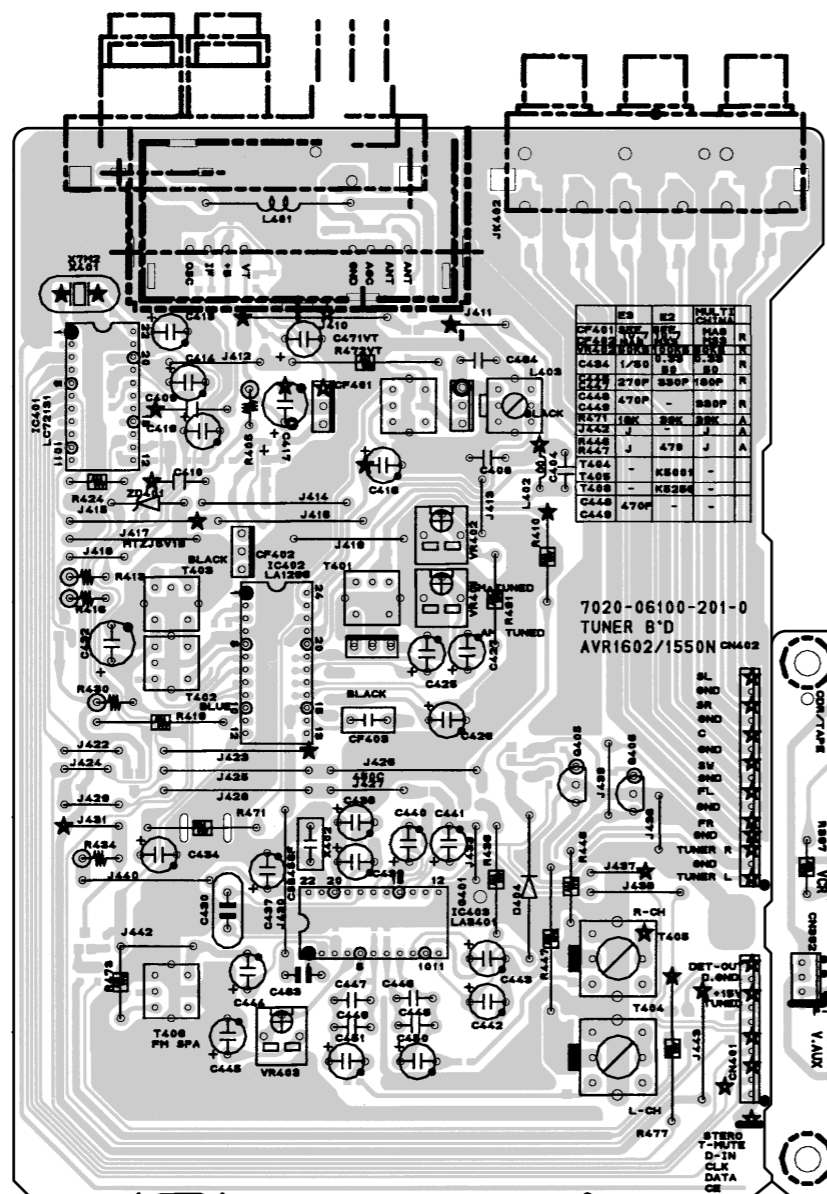

TACT S/W P.W.B.

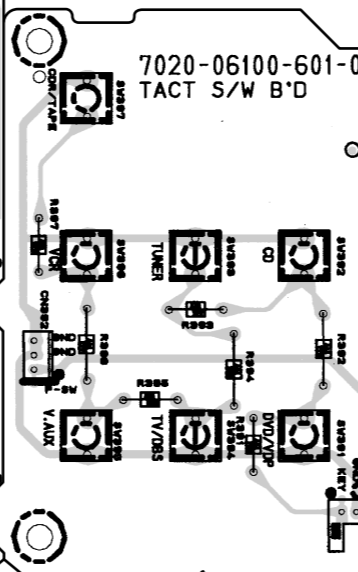

VIDEO P.W.B.

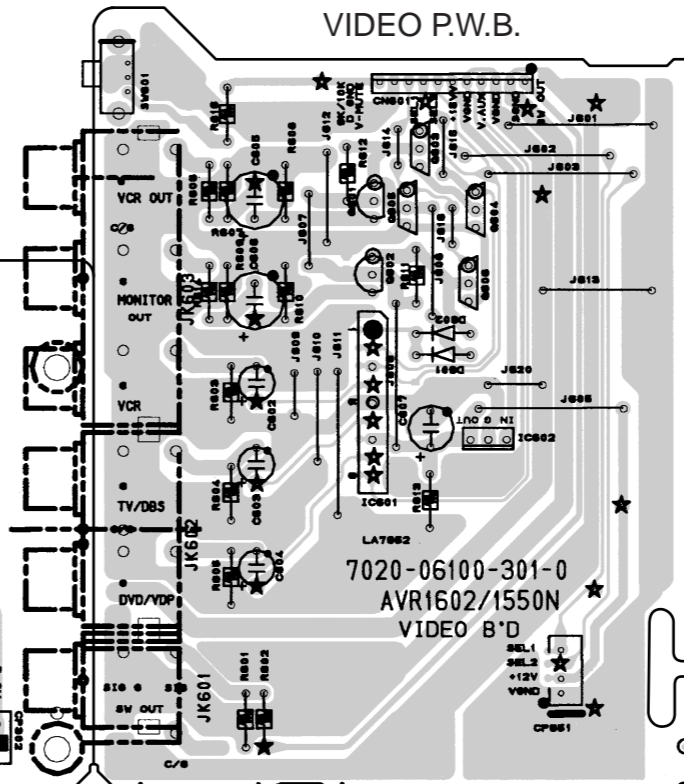

S-VIDEO P.W.B.

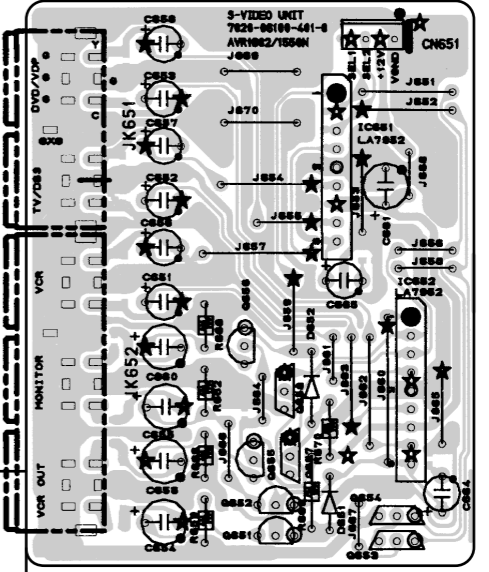

H/P P.W.B.

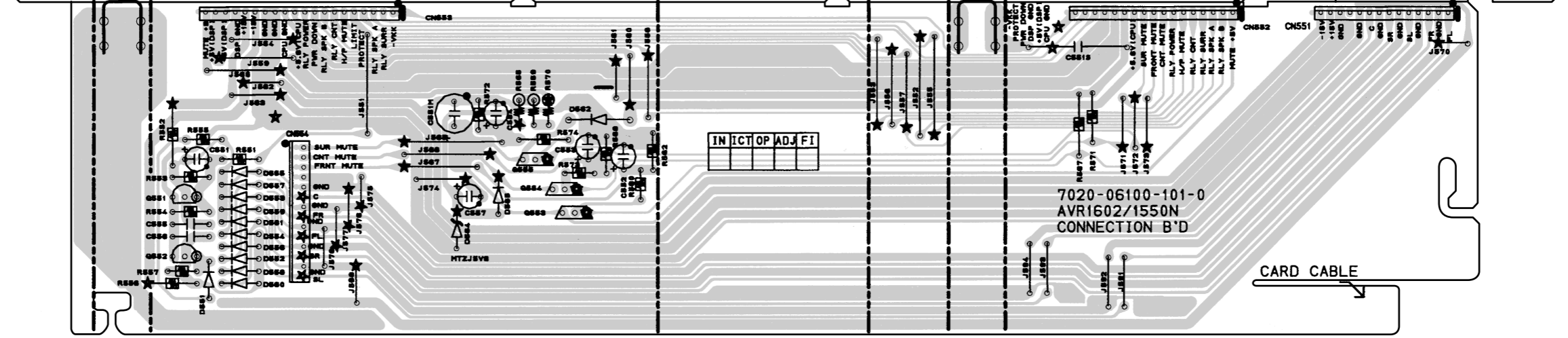
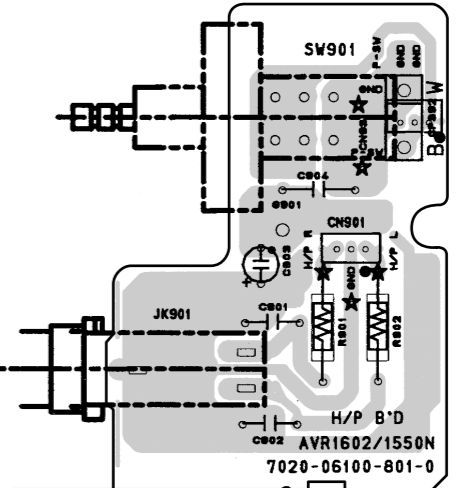

CONNECTION P.W.B.

COMPONENT SIDE

A
B
C
D
E

1 2 3 4 5 6 7 8

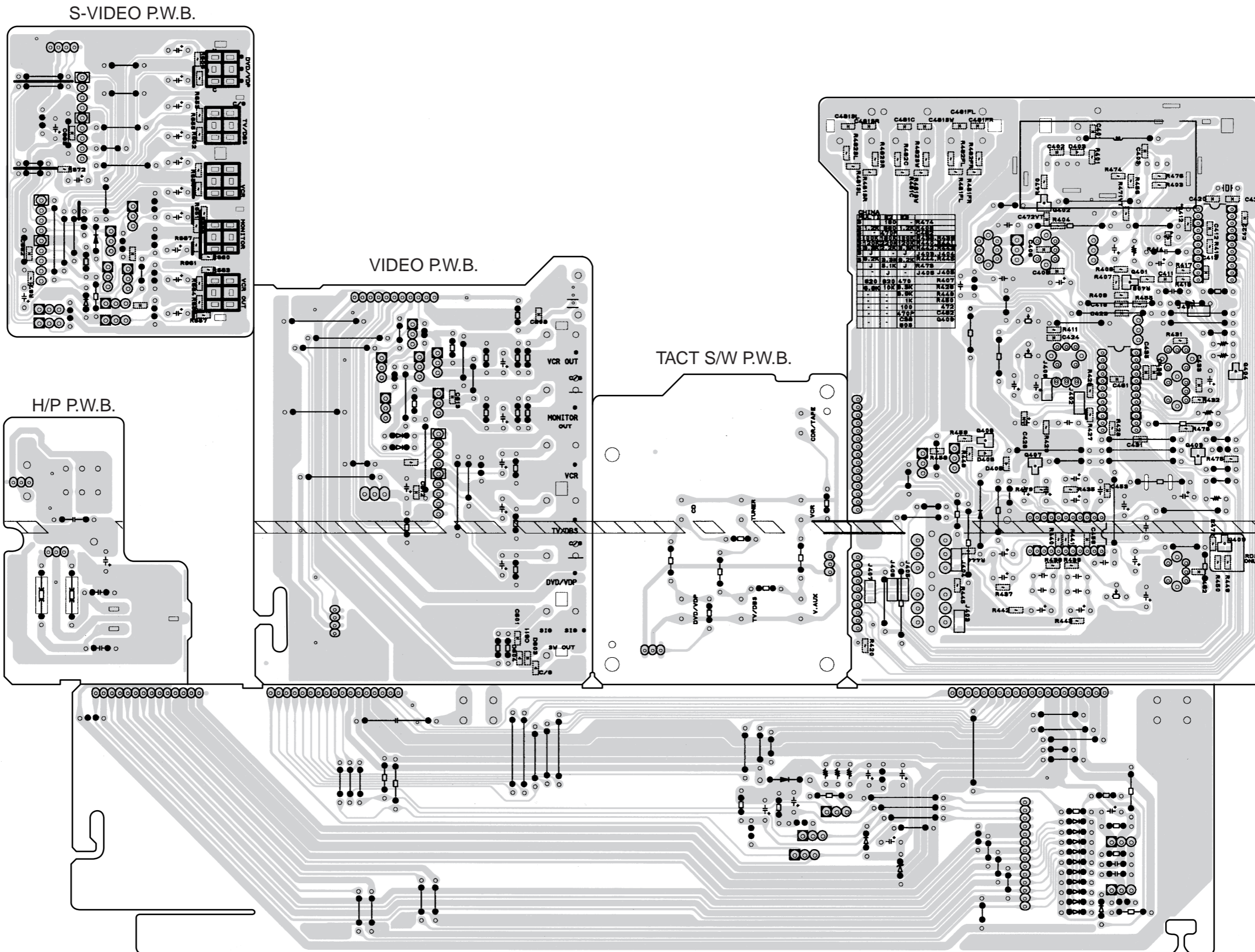

A
B
C
D
E

FOIL SIDE

CONNECTION P.W.B.

1 2 3 4 5 6 7 8

PRE AMP P.W.B. UNIT Ass'y

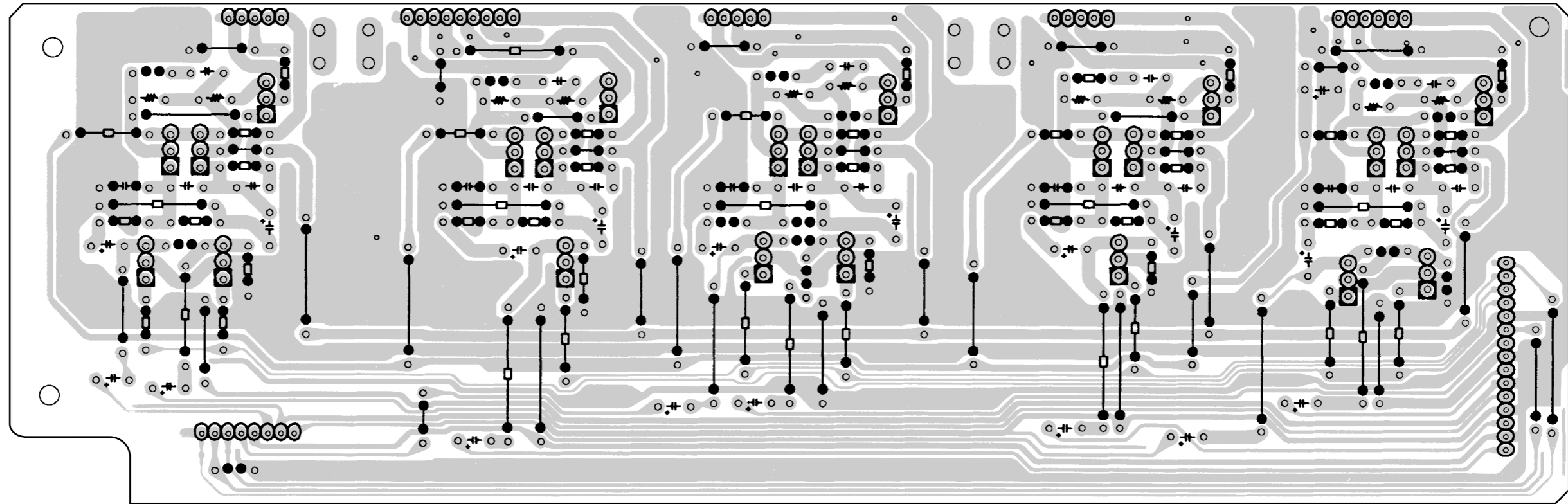
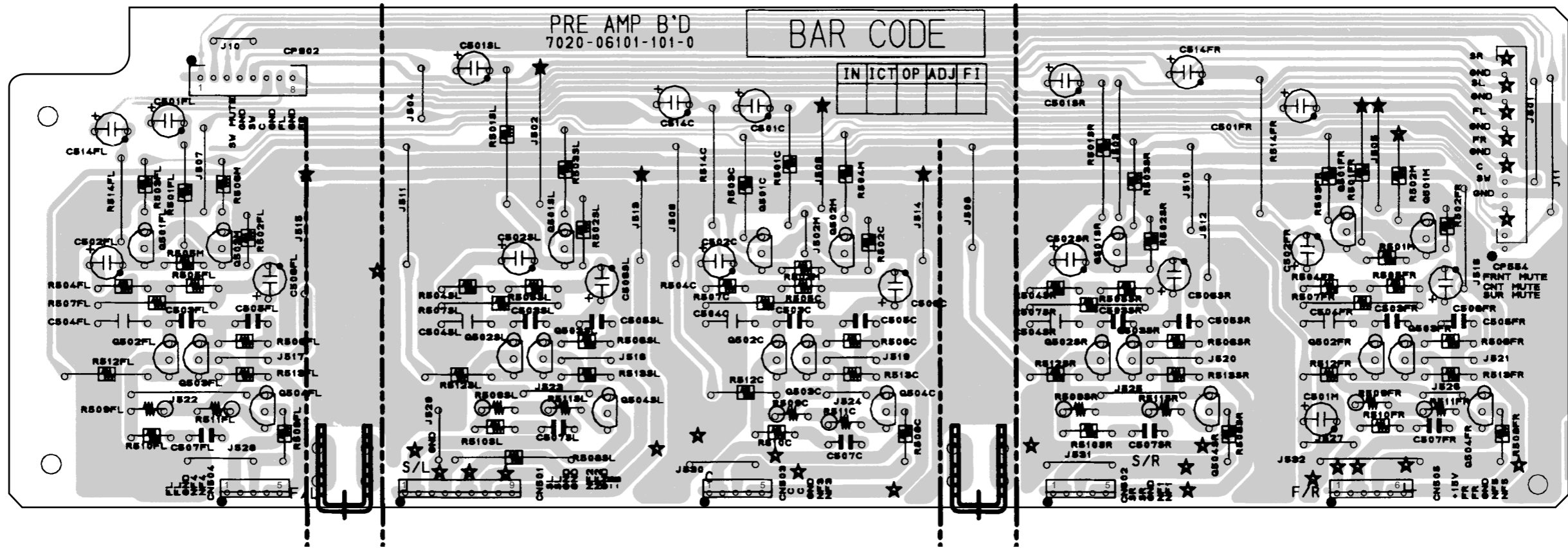

A
B
C
D
E

1 2 3 4 5 6 7 8

DSP P.W.B. UNIT Ass'y

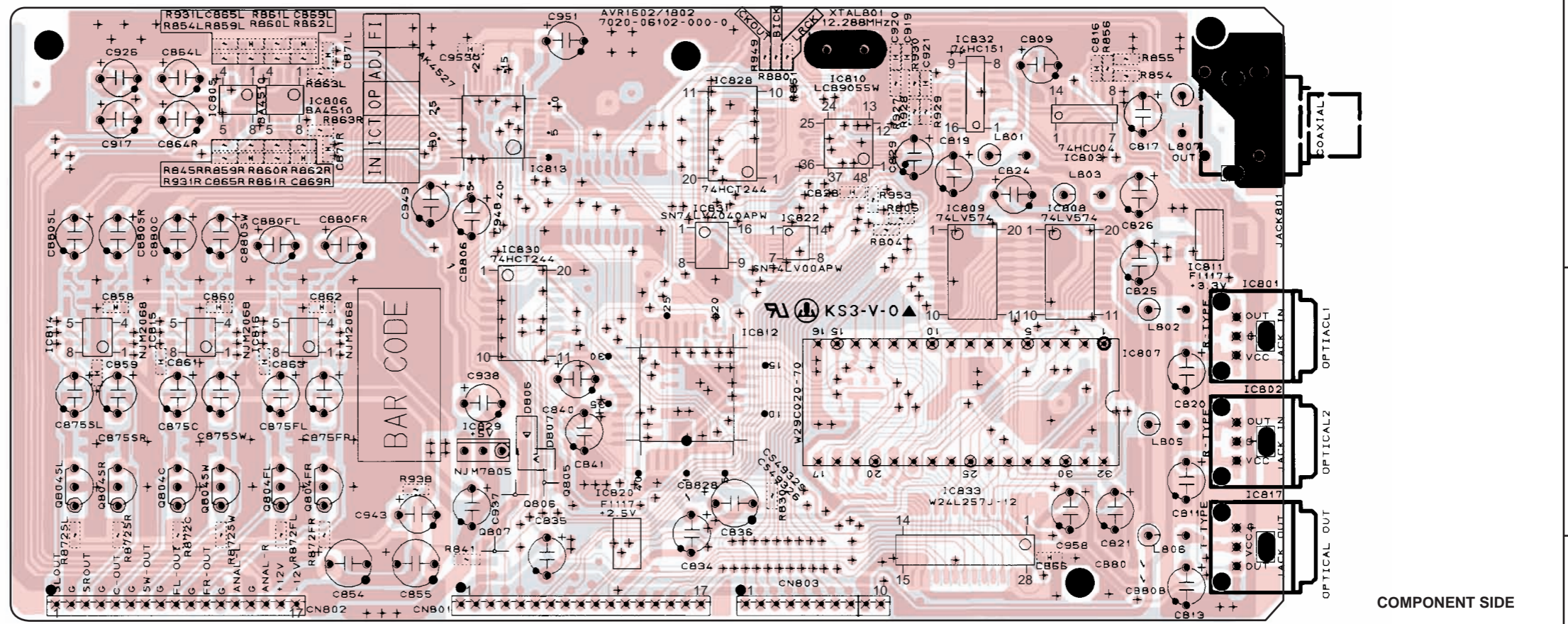

COMPONENT SIDE

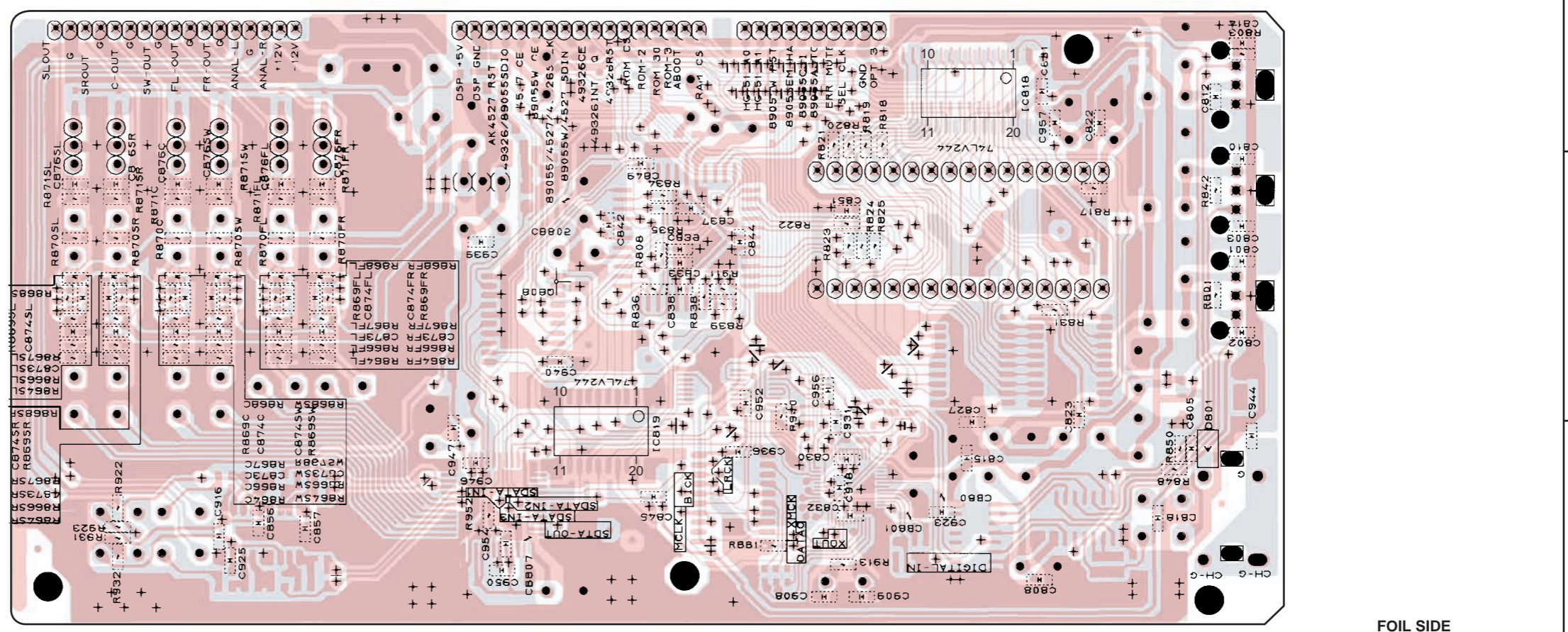

FOIL SIDE

A
B
C
D
E

1 2 3 4

VOLTAGE SEL P.W.B. UNIT Ass'y

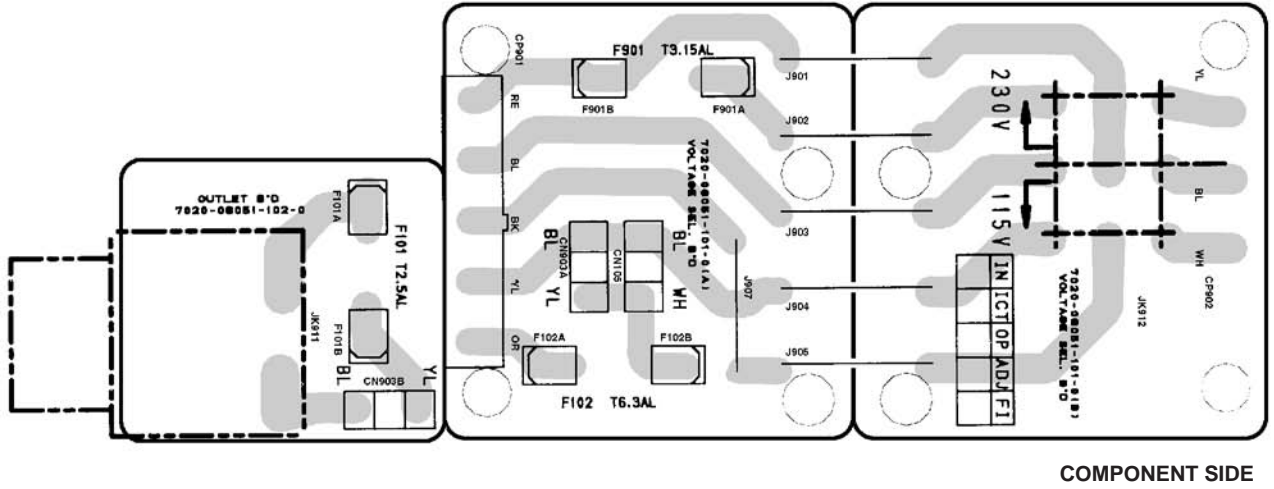

A

B

C

D

E

NOTE FOR PARTS LIST

- Part indicated with the mark "⊙" are not always in stock and possibly to take a long period of time for supplying, or in some case supplying of part may be refused.
- When ordering of part, clearly indicate "1" and "I" (i) to avoid mis-supplying.
- Ordering part without stating its part number can not be supplied.
- Part indicated with the mark "★" is not illustrated in the exploded view.
- Not including Carbon Film ±5%, 1/4W Type in the P.W.Board parts list. (Refer to the Schematic Diagram for those parts.)

WARNING:

Parts marked with this symbol   have critical characteristics.
Use ONLY replacement parts recommended by the manufacturer.

● **Resistors**

Ex.: RN 14K 2E 182 G FR
 Type Shape Power Resist- Allowable Others
 and per- ance error

RD : Carbon	2B : 1/8W	F : ±1%	P : Pulse-resistant type
RC : Composition	2E : 1/4W	G : ±2%	NL : Low noise type
RS : Metal oxide film	2H : 1/2W	J : ±5%	NB : Non-burning type
RW : Winding	3A : 1W	K : ±10%	FR : Fuse-resistor
RN : Metal film	3D : 2W	M : ±20%	F : Lead wire forming
RK : Metal mixture	3F : 3W		
	3H : 5W		

* **Resistance**

1 8 2 ⇒ 1800 ohm = 1.8 kohm
 ↑ ↑ ↑
 Indicates number of zeros after effective number.
 2-digit effective number.

• Units: ohm

1 R 2 ⇒ 1.2 ohm
 ↑ ↑ ↑
 1-digit effective number.
 2-digit effective number, decimal point indicated by R.

• Units: ohm

● **Capacitors**

Ex.: CE 04W 1H 2R2 M BP
 Type Shape Dielectric Capacity Allowable Others
 and per- strength error

CE : Aluminum foil electrolytic	0J : 6.3V	F : ±1%	HS : High stability type
CA : Aluminum solid electrolytic	1A : 10V	G : ±2%	BP : Non-polar type
CS : Tantalum electrolytic	1C : 16V	J : ±5%	HR : Ripple-resistant type
CQ : Film	1E : 25V	K : ±10%	DL : For charge and discharge
CK : Ceramic	1V : 35V	M : ±20%	HF : For assuring high frequency
CC : Ceramic	1H : 50V	Z : +80%	U : UL part
CP : Oil	2A : 100V	-20%	C : CSA part
CM : Mica	2B : 125V	P : +100%	W : UL-CSA type
CF : Metallized	2C : 160V	-0%	F : Lead wire forming
CH : Metallized	2D : 200V	C : ±0.25pF	
	2E : 250V	D : ±0.5pF	
	2H : 500V	= : Others	
	2J : 630V		

* **Capacity (electrolyte only)**

2 2 2 ⇒ 2200µF
 ↑ ↑ ↑
 Indicates number of zeros after effective number.
 2-digit effective number.

• Units: µF.

2 R 2 ⇒ 2.2µF
 ↑ ↑ ↑
 1-digit effective number.
 2-digit effective number, decimal point indicated by R.

• Units: µF.

* **Capacity (except electrolyte)**

2 2 2 ⇒ 2200pF=0.0022µF
 ↑ ↑ ↑
 (More than 2) — Indicates number of zeros after effective number.
 2-digit effective number.

• Units: pF.

2 2 1 ⇒ 220pF
 ↑ ↑ ↑
 (0 or 1) — Indicates number of zeros after effective number.
 2-digit effective number.

• Units: pF.

• When the dielectric strength is indicated in AC, "AC" is included after the dielectric strength value.

PARTS LIST OF P.W.B. UNIT ASS'Y

MAIN P.W.B. ASS'Y

Note : The symbols in the column "Remarks" indicate the following destinations.
 E3: U.S.A. & Canada model EU: U.S.A. model (AVR-682)
 E2: Europe model E1: Asia model
 E1C: China model E1H: Hong Kong model
 E1T: Taiwan R.O.C. model

Ref. No.	Part No.	Part Name	Remarks	Ref. No.	Part No.	Part Name	Remarks	
SEMICONDUCTORS GROUP								
IC101	963 0057 903	IC KIA7815AP		R106SL,106SR	244 2051 987	Metal film 4.7 ohm 1W	for E3,EU	
IC102	963 0044 806	IC NJM7915FA		R107C	244 2051 987	Metal film 4.7 ohm 1W		
IC103	960 0196 001	IC NJM7805FA		R107FL,107FR	244 2051 987	Metal film 4.7 ohm 1W		
IC104	963 0057 709	IC KIA7805AP		R107SL,107SR	244 2051 987	Metal film 4.7 ohm 1W		
IC105	960 0195 808	IC ICP-N15		R108C	244 2043 982	Metal film 0.22 ohm 1W		
IC701	960 0174 308	IC TC9273N-007		R108FL,108FR	244 2043 982	Metal film 0.22 ohm 1W		
IC702,703	960 0179 701	IC NJM2068DD		R108SL,108SR	244 2043 982	Metal film 0.22 ohm 1W		
Q104C	960 0196 506	Transistor KSC1845F		R109C	244 2043 982	Metal film 0.22 ohm 1W		
Q104FL,104FR	960 0196 506	Transistor KSC1845F		R109FL,109FR	244 2043 982	Metal film 0.22 ohm 1W		
Q104SL,104SR	960 0196 506	Transistor KSC1845F		R109SL,109SR	244 2043 982	Metal film 0.22 ohm 1W		
Q111-115	960 0196 904	Transistor DTC114YS		R110C	244 2043 982	Metal film 0.22 ohm 1W		
Q116	960 0196 409	Transistor 2SC1740SR		R110FL,110FR	244 2043 982	Metal film 0.22 ohm 1W		
Q117	960 0196 904	Transistor DTC114YS		R110SL,110SR	244 2043 982	Metal film 0.22 ohm 1W		
Q151	960 0196 409	Transistor 2SC1740SR		R111C	244 2043 982	Metal film 0.22 ohm 1W		
Q171	960 0005 202	Transistor KTC3198Y		R111FL,111FR	244 2043 982	Metal film 0.22 ohm 1W		
Q171A-171C	960 0196 302	Transistor KTA1268BL		R111SL,111SR	244 2043 982	Metal film 0.22 ohm 1W		
Q172-177	960 0005 202	Transistor KTC3198Y		R118C	244 2043 937	Metal oxide 10 ohm 1W(NB)		
Q178	960 0005 105	Transistor KTA1266Y		R118FL,118FR	244 2043 937	Metal oxide 10 ohm 1W(NB)		
Q179	960 0189 005	Transistor KSA916Y		R118SL,118SR	244 2043 937	Metal oxide 10 ohm 1W(NB)		
Q180,181	960 0196 302	Transistor KTA1268BL		R119C	244 2043 937	Metal oxide 10 ohm 1W(NB)		
D101-105	963 0020 309	Diode 1SS133T		R119FL,119FR	244 2043 937	Metal oxide 10 ohm 1W(NB)		
D121-126	963 0020 309	Diode 1SS133T		R119SL,119SR	244 2043 937	Metal oxide 10 ohm 1W(NB)		
D131A,131B	960 0197 107	Diode KBPC604		R135,136	963 0045 203	Winding 0.1 ohm 5W		
D132	963 0020 309	Diode 1SS133T		R141,142	244 2043 982	Metal film 0.22 ohm 1W		
D133,134	963 0046 202	Diode MTZJ18B		R148,149	244 2043 982	Metal film 0.22 ohm 1W		
D135	963 0020 309	Diode 1SS133T		R151	963 9003 343	Metal film 68 ohm 1/4W		
D136	963 0058 504	Diode MTZJ11B		R154	963 0043 108	Metal film 2.2 Mohm 1/2W		
D137	963 0020 309	Diode 1SS133T		R155,156	963 9003 039	Metal film 1 ohm 1/4W		
D138	963 0058 407	Diode 1N4007		R179	963 9003 055	Metal film 47 kohm 1/4W		
D141-146	963 0058 407	Diode 1N4007		R181	244 2051 987	Metal film 4.7 ohm 1W		
D148	963 0020 309	Diode 1SS133T		R184	244 2043 937	Metal oxide 10 ohm 1W(NB)		
D149,150	963 0058 407	Diode 1N4007		R185	963 9003 039	Metal film 1 ohm 1/4W		
D151	963 0020 309	Diode 1SS133T		R701L,701R	963 9004 339	Carbon chip 470 ohm 1/16W		
D152,153	963 0058 407	Diode 1N4007		R702L,702R	963 9004 339	Carbon chip 470 ohm 1/16W		
D154	963 0047 405	Diode MTZJ7.5B		R703L,703R	963 9004 339	Carbon chip 470 ohm 1/16W		
D157	963 0058 708	Diode MTZJ20B		R704L,704R	963 9004 339	Carbon chip 470 ohm 1/16W		
D158-160	963 0020 309	Diode 1SS133T		R705L,705R	963 9004 339	Carbon chip 470 ohm 1/16W		
RESISTORS GROUP								
R104C	244 2052 957	Metal film 5.6 kohm 1W		R706L,706R	963 9004 339	Carbon chip 470 ohm 1/16W		
R104FL,104FR	244 2052 957	Metal film 5.6 kohm 1W		R707L,707R	963 9004 339	Carbon chip 470 ohm 1/16W		
R104SL,104SR	244 2052 957	Metal film 5.6 kohm 1W		R710L,710R	963 9004 245	Carbon chip 2.2 Mohm 1/16W		
R105C	244 2052 957	Metal film 5.6 kohm 1W		R711L,711R	963 9004 245	Carbon chip 2.2 Mohm 1/16W		
R105FL,105FR	244 2052 957	Metal film 5.6 kohm 1W		R712L,712R	963 9004 245	Carbon chip 2.2 Mohm 1/16W		
R105SL,105SR	244 2052 957	Metal film 5.6 kohm 1W		R713L,713R	963 9004 245	Carbon chip 2.2 Mohm 1/16W		
R106C	244 2051 987	Metal film 4.7 ohm 1W		R714L,714R	963 9004 245	Carbon chip 2.2 Mohm 1/16W		
R106FL,106FR	244 2051 987	Metal film 4.7 ohm 1W		R715L,715R	963 9004 245	Carbon chip 2.2 Mohm 1/16W		
				R716L,716R	963 9004 245	Carbon chip 2.2 Mohm 1/16W		
				R725L,725R	960 9003 385	Carbon chip 100 ohm 1/16W		
				R726L,726R	963 9004 083	Carbon chip 100 kohm 1/16W		
				R728L,728R	963 9004 300	Carbon chip 39 kohm 1/16W		
				R729L,729R	963 9003 385	Carbon chip 100 ohm 1/16W		
				R730L,730R	963 9004 083	Carbon chip 100 kohm 1/16W		

Ref. No.	Part No.	Part Name	Remarks	Ref. No.	Part No.	Part Name	Remarks
R731L,731R	963 9004 300	Carbon chip 39 kohm 1/16W		C198FL,198FR	960 9006 202	Ceramic 0.01uF/50V	for E2
R732L,732R	963 9004 300	Carbon chip 39 kohm 1/16W		C198SL,198SR	960 9006 202	Ceramic 0.01uF/50V	for E2
R751L,751R	963 9004 083	Carbon chip 100 kohm 1/16W		C199FL,199FR	960 9006 202	Ceramic 0.01uF/50V	for E2
VR101-105	960 0091 601	Semi fixed resistor 1 kohm		C701L,701R	963 9004 575	Ceramic chip 100pF/50V	for E2
CAPACITORS GROUP				C702L,702R	963 9004 575	Ceramic chip 100pF/50V	for E2
C101C		Electrolytic 47uF/50V		C703L,703R	963 9004 575	Ceramic chip 100pF/50V	for E2
C101FL,101FR		Electrolytic 47uF/50V		C704L,704R	963 9004 575	Ceramic chip 100pF/50V	for E2
C101SL,101SR		Electrolytic 47uF/50V		C705L,705R	963 9004 575	Ceramic chip 100pF/50V	for E2
C102C		Electrolytic 10uF/35V		C706L,706R	963 9004 575	Ceramic chip 100pF/50V	for E2
C102FL,102FR		Electrolytic 10uF/35V		C707L,707R	963 9004 575	Ceramic chip 100pF/50V	for E2
C102SL,102SR		Electrolytic 10uF/35V		C716L,716R		Electrolytic 10uF/35V	
C103C	963 9003 084	Ceramic 100pF/500V		C718L,718R		Electrolytic 10uF/35V	
C103FL,103FR	963 9003 084	Ceramic 100pF/500V		C719L,719R		Electrolytic 10uF/35V	
C103SL,103SR	963 9003 084	Ceramic 100pF/500V		C720L,720R	963 9003 152	Mylar film 0.068uF/100V	
C104C	963 9003 084	Ceramic 100pF/500V		C721L,721R	963 9003 152	Mylar film 0.068uF/100V	
C104FL,104FR	963 9003 084	Ceramic 100pF/500V		C723L,723R		Electrolytic 10uF/35V	
C104SL,104SR	963 9003 084	Ceramic 100pF/500V		C724L,724R	963 9004 698	Ceramic chip 0.01uF/50V	
C105C	960 9003 108	Ceramic 0.022uF/25V		C725,726	963 9004 698	Ceramic chip 0.01uF/50V	
C105FL,105FR	960 9003 108	Ceramic 0.022uF/25V		C727,728		Electrolytic 10uF/35V	
C105SL,105SR	960 9003 108	Ceramic 0.022uF/25V		OTHER PARTS GROUP			
C107C	963 9003 097	Mylar film 0.1uF/250V		CN201	963 0046 309	8P connector base	1
C107FL,107FR	963 9003 097	Mylar film 0.1uF/250V		CN202	963 0075 707	4P connector base	1
C107SL,107SR	963 9003 097	Mylar film 0.1uF/250V		CN203	963 0046 309	8P connector base	1
C131-135	963 9003 097	Mylar film 0.1uF/250V		CN701	960 0117 103	12P connector base	1
C136,137	963 0087 203	Electrolytic 10000uF/63V		CN702	963 0046 600	11P connector base	
C138		Electrolytic 1uF/50V		CP101	960 0197 505	2P connector base	1
C141-143	963 0021 900	Mylar film 0.047uF/100V		CP102	960 0123 304	2P connector base	for E3,EU,E2,E1C 1
C144	963 9003 110	Electrolytic 4700uF/35V		CP102	963 0066 208	3P connector base	for E1,E1H,E1T 1
C145	963 9003 123	Electrolytic 1000uF/35V		CP103	963 0066 208	3P connector base	1
C146		Electrolytic 1uF/50V		CP104	960 0128 804	6P connector base	1
C148		Electrolytic 1uF/50V		CP105	960 0123 304	2P connector base	for E2,E1,E1H,E1T 1
C150-152	963 0021 900	Mylar film 0.047uF/100V		CP106	960 0123 207	3P connector base	1
C153	963 0021 104	Electrolytic 6800uF/16V		CP303	963 0075 600	6P connector base	1
C154		Electrolytic 10uF/35V		CP501	963 0046 901	9P connector base	1
C155	963 0020 202	Ceramic 0.1uF/50V		CP502-504	963 0048 608	5P connector base	3
C157		Electrolytic 1uF/50V		CP505	963 0049 500	6P connector base	1
C158	963 9003 136	Electrolytic 1000uF/25V		CP553	963 0048 802	20P connector base	1
C159		Electrolytic 1uF/50V		CP901	963 0048 909	3P connector base	1
C161		Electrolytic 10uF/35V		CP931	960 0123 304	2P connector base	for E2,E1,E1C,E1H,E1T 1
C171		Electrolytic 100uF/10V		△ F101	960 0188 705	Fuse 125V-8A	for E3,EU 1
C171A-171C	963 0020 202	Ceramic 0.1uF/50V		△ F101	960 0142 602	Fuse 250V-T2.5A	for E2 1
C172,173		Electrolytic 220uF/6.3V		F101A,101B	960 0005 804	Fuse clip	for E3,EU,E2 2
C174		Electrolytic 10uF/35V		△ F102	960 0188 705	Fuse 125V-8A	for E3,EU 1
C175		Electrolytic 4.7uF/50V		△ F102	963 0044 709	Fuse 250V-T3.15A	for E2,E1C 1
C176,177		Electrolytic 1uF/50V		F102A,102B	960 0005 804	Fuse clip	for E3,EU,E2,E1C 2
C178	963 9003 149	Electrolytic 330uF/63V		GND101-103	960 9006 600	Terminal	3
△ C181	963 0076 104	Ceramic 4700pF/250V(AC)					
C182	963 9004 795	Electrolytic 10uF/100V	for E2				
C191-197		Ceramic 2200pF/16V	for E2				
C198C	960 9006 202	Ceramic 0.01uF/50V	for E2				

Note : The symbols in the column "Remarks" indicate the following destinations.
 E3: U.S.A. & Canada model EU: U.S.A. model (AVR-682)
 E2: Europe model E1: Asia model
 E1C: China model E1H: Hong Kong model
 E1T: Taiwan R.O.C. model

CPU P.W.B. ASS'Y

Ref. No.	Part No.	Part Name	Remarks	Q'ty	Ref. No.	Part No.	Part Name	Remarks
JK103	960 0194 809	2P Terminal		1	SEMICONDUCTORS GROUP			
△ JK104	960 0181 508	AC outlet	for E3,EU	1	IC201	963 0084 303	IC CXP740096-135Q	for E2
L101C	963 0049 005	Inductor 0.5uH		1	IC202	963 0057 602	IC TDA7330BD	
L101FL,101FR	963 0049 005	Inductor 0.5uH		2	IC221	963 0080 201	IC KIC9164AN	
L101SL,101SR	963 0049 005	Inductor 0.5uH		2	IC231	960 0179 604	IC M62446FP	
RLY101-104	960 0181 702	Relay G5PA-28 24V 5A		4	IC241	960 0179 701	IC NJM2068DD	
RLY105	963 0071 303	Relay RSB24S 24V 2A30VDC		1	IC251	960 0179 701	IC NJM2068DD	
RLY106	960 0181 605	Relay G5PA-1-8 12V 5A		1	IC261	960 0179 701	IC NJM2068DD	
TP101-105	960 0161 405	3P connector base		5	IC271	960 0179 701	IC NJM2068DD	
	—	Heat sink		1	IC281	960 0179 701	IC NJM2068DD	
	—	Heat sink		1	IC291	960 0179 701	IC NJM2068DD	
	963 0068 400	Condenser cover	for E2,E1,E1C,E1H,E1T	1	IC301	960 0180 004	IC LC75721E	
	963 0060 000	Fuse label F101	for E2	1	IC302	963 0074 504	IC BU2090F	
	963 0090 504	Fuse label F102	for E1C	1	RMC301	960 0181 100	Remote sensor NJL64H380A	
△	960 0185 708	Sub trans.	for E3,EU	1	Q201	963 0075 202	Transistor DTC144EK	
△	960 0185 711	Sub trans.	for E2	1	Q202	963 0045 902	Transistor 2SC2412K	
△	960 0185 737	Sub trans.	for E1,E1H,E1T	1	Q203	963 0075 309	Transistor DTA114ES	
△	960 0185 724	Sub trans.	for E1C	1	Q204,205	960 0196 603	Transistor KTC2874B	
	963 0018 007	Screw 3x8 CBTS(B)		3	Q231	963 0075 309	Transistor DTA114ES	
	960 0158 308	4P Terminal		1	Q232	963 0075 503	Transistor DTC144ES	
	963 0074 009	8P Terminal		1	Q251,252	960 0196 807	FET 2SK117Y	
	960 0194 702	4P pin jack		2	Q291C	960 0196 807	FET 2SK117Y	
	960 0188 307	6P pin jack		1	Q291FL,291FR	960 0196 807	FET 2SK117Y	
					Q291SW	960 0196 807	FET 2SK117Y	
					Q294	963 0058 203	Transistor DTA114EK	
					Q295	963 0075 202	Transistor DTC144EK	
					Q296	963 0058 203	Transistor DTA114EK	
					Q297	963 0075 202	Transistor DTC144EK	
					Q310	963 0075 008	Transistor DTA144EK	
					Q311	963 0075 202	Transistor DTC144EK	
					Q312	963 0075 008	Transistor DTA144EK	
					Q313	963 0075 202	Transistor DTC144EK	
					Q314	963 0075 008	Transistor DTA144EK	
					Q315	963 0075 202	Transistor DTC144EK	
					D201	960 0197 000	Diode KDS160	
					D202	963 0058 407	Diode 1N4007	
					D203	963 0020 309	Diode 1SS133	
					D204,205	960 0197 000	Diode KDS160	for E2
					D206	963 0020 309	Diode 1SS133	
					D251,252	963 0020 309	Diode 1SS133	
					D261	963 0058 407	Diode 1N4007	
					D291-294	960 0197 000	Diode KDS160	
					D302-304	963 0020 309	Diode 1SS133	
					D305	960 0197 000	Diode KDS160	
					D308,309	960 0197 000	Diode KDS160	

Ref. No.	Part No.	Part Name	Remarks	Ref. No.	Part No.	Part Name	Remarks
ZD201	963 0047 502	Zener diode MTZJ3.3B		R286C	963 9004 232	Carbon chip 220 kohm 1/16W	
ZD271,272	960 0222 603	Zener diode MTZJ7.5A		R286FL,286FR	963 9004 232	Carbon chip 220 kohm 1/16W	
ZD301	960 0095 801	Zener diode MTZJ6.8B		R286SL,286SR	963 9004 232	Carbon chip 220 kohm 1/16W	
ZD306,307	960 0095 607	Zener diode MTZJ5.6B		R286SW	963 9004 232	Carbon chip 220 kohm 1/16W	
LED301-304	960 0197 204	LED PI5-RD/HL50RDRF4T		R292C	963 9003 385	Carbon chip 100 ohm 1/16W	
LED306-309	960 0197 204	LED PI5-RD/HL50RDRF4T		R292FL,292FR	963 9003 385	Carbon chip 100 ohm 1/16W	
RESISTORS GROUP				R292SL,292SR	963 9003 385	Carbon chip 100 ohm 1/16W	
R202	963 9003 398	Carbon chip 1 kohm 1/16W		R292SW	963 9003 385	Carbon chip 100 ohm 1/16W	
R203,204	963 9004 342	Carbon chip 4.7 kohm 1/16W		R293C	963 9004 355	Carbon chip 47 kohm 1/16W	
R205	963 9004 070	Carbon chip 10 kohm 1/16W		R293FL,293FR	963 9004 355	Carbon chip 47 kohm 1/16W	
R206	963 9004 232	Carbon chip 220 kohm 1/16W		R293SL,293SR	963 9004 355	Carbon chip 47 kohm 1/16W	
R209	963 9004 070	Carbon chip 10 kohm 1/16W		R293SW	963 9004 355	Carbon chip 47 kohm 1/16W	
R211	963 9004 070	Carbon chip 10 kohm 1/16W		R294C	963 9004 481	Carbon chip 8.2 kohm 1/16W	
R212	963 9003 398	Carbon chip 1 kohm 1/16W		R294FL,294FR	963 9004 371	Carbon chip 5.1 kohm 1/16W	
R213-215	963 9004 122	Carbon chip 12 kohm 1/16W		R294SW	963 9005 338	Carbon chip 16 kohm 1/10W	
R216	963 9004 070	Carbon chip 10 kohm 1/16W	for E3,EU,E2	R295SW	963 9004 355	Carbon chip 47 kohm 1/16W	
R217	963 9004 070	Carbon chip 10 kohm 1/16W	for E3,EU	R296C	963 9005 341	Carbon chip 13 kohm 1/10W	
R218	963 9004 070	Carbon chip 10 kohm 1/16W	for E1,E1C,E1H,E1T	R296FL,296FR	963 9004 834	Carbon chip 5.6 kohm 1/16W	
R218,219	963 9004 177	Carbon chip 18 kohm 1/16W	for E2	R296SL,296SR	963 9005 341	Carbon chip 13 kohm 1/10W	
R220	963 9004 070	Carbon chip 10 kohm 1/16W		R296SW	963 9004 122	Carbon chip 12 kohm 1/16W	
R223,224	963 9003 372	Carbon chip 0 ohm 1/16W	for E3,EU,E1,E1C,E1H,E1T	R297C	963 9004 216	Carbon chip 2.2 kohm 1/16W	
R223,224	963 9004 070	Carbon chip 10 kohm 1/16W	for E2	R297FL,297FR	963 9003 398	Carbon chip 1 kohm 1/16W	
R225	963 9004 245	Carbon chip 2.2 Mohm 1/16W	for E2	R297SL,297SR	963 9004 216	Carbon chip 2.2 kohm 1/16W	
R226	963 9004 070	Carbon chip 10 kohm 1/16W		R297SW	963 9005 008	Carbon chip 620 ohm 1/16W	
R227	963 9003 398	Carbon chip 1 kohm 1/16W		R298SW	963 9004 083	Carbon chip 100 kohm 1/16W	
R228	963 9004 368	Carbon chip 470 kohm 1/16W		R299C	963 9004 339	Carbon chip 470 ohm 1/16W	
R230	963 9004 229	Carbon chip 22 kohm 1/16W		R299FL,299FR	963 9004 339	Carbon chip 470 ohm 1/16W	
R231,232	244 2051 961	Metal film 100 ohm 1W		R299SL,299SR	963 9004 339	Carbon chip 470 ohm 1/16W	
R236	963 9004 216	Carbon chip 2.2 kohm 1/16W		R299SW	963 9003 398	Carbon chip 1 kohm 1/16W	
R237	963 9004 070	Carbon chip 10 kohm 1/16W		R301-304	963 9004 436	Carbon chip 680 ohm 1/16W	
R238	963 9004 216	Carbon chip 2.2 kohm 1/16W		R306-309	963 9004 436	Carbon chip 680 ohm 1/16W	
R241-248	963 9004 339	Carbon chip 470 ohm 1/16W		R315	963 9004 070	Carbon chip 10 kohm 1/16W	
R252	963 9004 449	Carbon chip 6.8 kohm 1/16W		R332	963 9004 342	Carbon chip 4.7 kohm 1/16W	
R253	963 9004 834	Carbon chip 5.6 kohm 1/16W		R381	963 9004 465	Carbon chip 75 ohm 1/16W	
R254	963 9004 481	Carbon chip 8.2 kohm 1/16W		R382,383	963 9004 339	Carbon chip 470 ohm 1/16W	
R255	963 9003 385	Carbon chip 100 ohm 1/16W		R384,385	963 9004 245	Carbon chip 2.2 Mohm 1/16W	
R256	963 9004 083	Carbon chip 100 kohm 1/16W		RG01	963 9004 397	Carbon chip 56 kohm 1/16W	
R258	963 9004 070	Carbon chip 10 kohm 1/16W		RP01-38	963 9004 397	Carbon chip 56 kohm 1/16W	
R259	963 9004 216	Carbon chip 2.2 kohm 1/16W		CAPACITORS GROUP			
R261L,261R	963 9004 342	Carbon chip 4.7 kohm 1/16W		BC201	963 0061 504	Electric double layer 8200uF/5.5V	
R262L,262R	963 9004 151	Carbon chip 15 kohm 1/16W		C201	963 9004 546	Ceramic 0.01uF/16V	
R263L,263R	963 9004 151	Carbon chip 15 kohm 1/16W		C202	963 9004 711	Ceramic chip 0.1uF/50V	
R264L,264R	963 9003 385	Carbon chip 100 ohm 1/16W		C203	963 9004 698	Ceramic chip 0.01uF/50V	
R265L,265R	963 9004 083	Carbon chip 100 kohm 1/16W		C204		Electrolytic 4.7uF/50V	
R266L,266R	963 9004 410	Carbon chip 6.2 kohm 1/16W		C205	963 9004 711	Ceramic chip 0.1uF/50V	
R271	244 2051 958	Metal film 220 ohm 1W		C206		Electrolytic 47uF/10V	for E2
R273	963 9005 325	Carbon chip 2.7 kohm 1/16W		C207	963 9004 546	Ceramic 0.01uF/16V	for E2
R274	244 2051 958	Metal film 220 ohm 1W					
R282-284	963 9003 385	Carbon chip 100 ohm 1/16W					

Ref. No.	Part No.	Part Name	Remarks	Ref. No.	Part No.	Part Name	Remarks	Q'ty
C208	963 9005 354	Ceramic chip 270pF/50V	for E2	C305		Electrolytic 47uF/16V		
C209		Electrolytic 10uF/35V	for E2	C306	963 9004 766	Mylar film 0.1uF/100V		
C210	963 9004 698	Ceramic chip 0.01uF/50V	for E2	C307		Electrolytic 1uF/50V		
C211,212	963 9004 614	Ceramic chip 27pF/50V	for E2	C308,309	963 0021 900	Mylar film 0.047uF/100V		
C213		Electrolytic 0.1uF/50V		C310		Electrolytic 1uF/50V		
C214		Electrolytic 1uF/50V		C311	963 9005 406	Ceramic chip 30pF/50V		
C219-226	963 9004 753	Ceramic chip 0.047uF/50V		C312		Electrolytic 47uF/16V		
C231		Electrolytic 47uF/25V		C313	963 9005 419	Mylar film 0.047uF/63V		
C233		Electrolytic 47uF/25V		C316,317	963 9004 698	Ceramic chip 0.01uF/50V		
C236		Electrolytic 47uF/25V		C321	963 9004 685	Ceramic chip 1000pF/50V		
C238		Electrolytic 47uF/25V		C322	963 9004 575	Ceramic chip 100pF/50V		
C241-246	963 9004 753	Ceramic chip 0.047uF/50V		C324	963 9004 575	Ceramic chip 100pF/50V		
C251	963 9004 575	Ceramic chip 100pF/50V		C333	963 9004 575	Ceramic chip 100pF/50V		
C252	963 9004 643	Ceramic chip 47pF/50V		C381		Electrolytic 47uF/10V		
C253		Electrolytic 10uF/35V		C382,383	963 9004 575	Ceramic chip 100pF/50V		
C261-268	963 9004 520	Ceramic 100pF/50V		C384,385		Electrolytic 1uF/50V		
C261L,261R	963 9004 575	Ceramic chip 100pF/50V		OTHER PARTS GROUP				
C262L,262R	963 9004 627	Ceramic chip 33pF/50V		BD201,202	963 0053 800	Beads inductor		2
C263L,263R		Electrolytic 10uF/35V		CN105	963 0089 405	2P connector cord	for E2	1
C271		Electrolytic 47uF/10V		CN302	963 0087 300	3P connector cord		1
C272		Electrolytic 1uF/50V		CN303	963 0090 407	6P connector cord		1
C273		Electrolytic 47uF/10V		CP201	963 0046 804	8P connector base		1
C274		Electrolytic 0.33uF/50V		CP202	963 0075 804	4P connector base		1
C275	963 9005 367	Ceramic chip 0.015uF/50V		CP203	963 0046 804	8P connector base		1
C276,277		Electrolytic 3.3uF/50V		CP301A	963 0075 901	15P FPC base		1
C278		Electrolytic 0.33uF/50V		CP301B	960 0217 524	15P FPC base		1
C279	963 9005 367	Ceramic chip 0.015uF/50V		CP303	963 0049 102	3P connector base		1
C280,281	963 9005 370	Ceramic chip 8200pF/50V		CP401	963 0047 007	10P connector base		1
C282	963 9004 575	Ceramic chip 100pF/50V		CP402	963 0049 209	15P connector base		1
C285BL,285BR		Electrolytic 4.7uF/50V		CP551	960 0123 003	14P connector base		1
C285C		Electrolytic 4.7uF/50V		CP552	963 0049 306	17P connector base		1
C285FL,285FR		Electrolytic 4.7uF/50V		CP601	963 0047 104	11P connector base		1
C285SL,285SR		Electrolytic 4.7uF/50V		CP701	960 0116 803	12P connector base		1
C285SW		Electrolytic 4.7uF/50V		CP702	963 0047 104	11P connector base		1
C292C		Electrolytic 4.7uF/50V		CP801,802	963 0049 306	17P connector base		2
C292FL,292FR		Electrolytic 10uF/35V		CP803	963 0046 804	8P connector base		1
C292SL,292SR		Electrolytic 10uF/35V		FL301	960 0180 509	FLT 16-ST-42GNK		1
C292SW		Electrolytic 4.7uF/50V		G301	—	1P lug wire L60 BK		1
C294C	963 9005 383	Ceramic chip 2700pF/50V		JK301	963 0067 508	3P pin jack		1
C294FL,294FR	963 9005 396	Ceramic chip 4700pF/50V		L301	960 0128 008	Inductor 100uH		1
C295C	963 9004 575	Ceramic chip 100pF/50V		L302	960 0010 307	Inductor 10uH		1
C295FL,295FR	963 9004 672	Ceramic chip 680pF/50V		SW301B,301C	963 0045 708	Tact switch		2
C296C	963 9004 630	Ceramic chip 39pF/50V		SW302A-302C	963 0045 708	Tact switch		3
C296FL,296FR	963 9005 422	Ceramic chip 82pF/50V		SW303A-303C	963 0045 708	Tact switch		3
C296SL,296SR	963 9004 630	Ceramic chip 39pF/50V						
C296SW	963 9004 575	Ceramic chip 100pF/50V						
C297SW		Electrolytic 4.7uF/50V						
C301		Electrolytic 10uF/50V						
C302	963 9004 753	Ceramic chip 0.047uF/50V						
C303		Electrolytic 47uF/10V						
C304	963 9004 737	Ceramic chip 0.022uF/25V						

Note : The symbols in the column "Remarks" indicate the following destinations.
 E3: U.S.A. & Canada model EU: U.S.A. model (AVR-682)
 E2: Europe model E1: Asia model
 E1C: China model E1H: Hong Kong model
 E1T: Taiwan R.O.C. model

CNT P.W.B. ASS'Y

Ref. No.	Part No.	Part Name	Remarks	Q'ty	Ref. No.	Part No.	Part Name	Remarks
SW304B,304C	963 0045 708	Tact switch		2	SEMICONDUCTORS GROUP			
SW305B,305C	963 0045 708	Tact switch		2	IC401	963 0043 700	IC LC72131	
SW306B,306C	963 0045 708	Tact switch		2	IC402	963 0043 904	IC LA1266	
SW307B,307C	963 0045 708	Tact switch		2	IC403	963 0044 000	IC LA3401	
SW308B,308C	963 0045 708	Tact switch		2	IC601	960 0180 101	IC LA7952	
SW309B,309C	963 0045 708	Tact switch		2	IC602	963 0074 902	IC NJM7812FA	
SW310B,310C	963 0045 708	Tact switch		2	IC651,652	960 0180 101	IC LA7952	for E3,EU,E1,E1C,E1H,E1T
SW311B,311C	963 0045 708	Tact switch		2	Q401	963 0058 300	Transistor KTC3880S	
VEC301	960 0181 207	Encoder EC16B2420431		1	Q402	963 0075 105	Transistor DTC114EK	
X201	960 0181 003	Ceramic resonator CST12.0MTW		1	Q403,404	963 0058 203	Transistor DTA114EK	
X202	960 0091 818	Crystal 4.332MHz	for E2	1	Q405,406	960 0196 603	Transistor KTC2874B	
	960 0184 408	FLT holder		1	Q407	963 0024 208	Transistor DTC114YK	
△	960 0143 203	AC outlet	for E2	1	Q408	963 0058 203	Transistor DTA114EK	
	—	Wire clamp	for E3,EU,E1,E1C,E1H,E1T	2	Q409	963 0058 300	Transistor KTC3880S	for E2
					Q551	960 0196 700	Transistor KTC3200BL	
					Q552	960 0196 302	Transistor KTA1268BL	
					Q553-555	963 0075 309	Transistor DTA114ES	
					Q601,602	960 0096 800	Transistor 2SC3199Y	
					Q603,604	960 0196 904	Transistor DTC114YS	
					Q605,606	963 0075 406	Transistor DTC114TS	
					Q651,652	960 0096 800	Transistor 2SC3199Y	for E3,EU,E1,E1C,E1H,E1T
					Q653,654	960 0196 904	Transistor DTC114YS	for E3,EU,E1,E1C,E1H,E1T
					Q655,656	960 0096 800	Transistor 2SC3199Y	for E3,EU,E1,E1C,E1H,E1T
					Q657,658	960 0196 904	Transistor DTC114YS	for E3,EU,E1,E1C,E1H,E1T
					D403	960 0197 000	Diode KDS160	
					D404	963 0020 309	Diode 1SS133	
					D405,406	960 0197 000	Diode KDS160	
					D551-561	963 0020 309	Diode 1SS133	
					D562	963 0058 407	Diode 1N4007	
					D564	960 0095 607	Zener diode MTZJ5.6B	
					D565	963 0020 309	Diode 1SS133	
					D601,602	963 0020 309	Diode 1SS133	
					D651,652	963 0020 309	Diode 1SS133	for E3,EU,E1,E1C,E1H,E1T
					ZD401	960 0095 500	Zener diode MTZJ5.1B	
					RESISTORS GROUP			
					R401	963 9004 821	Carbon chip 10 ohm 1/16W	
					R403	963 9004 339	Carbon chip 470 ohm 1/16W	
					R404	963 9004 083	Carbon chip 100 kohm 1/16W	
					R405	960 9003 807	Metal film 100 ohm 1/4W	
					R406	963 9004 342	Carbon chip 4.7 kohm 1/16W	
					R407	963 9004 339	Carbon chip 470 ohm 1/16W	for E3,EU
					R407	963 9005 008	Carbon chip 620 ohm 1/16W	for E2,E1,E1C,E1H,E1T
					R408	963 9004 119	Carbon chip 1.2 kohm 1/16W	for E3,EU,E1,E1C,E1H,E1T

Ref. No.	Part No.	Part Name	Remarks	Ref. No.	Part No.	Part Name	Remarks
R408	963 9004 436	Carbon chip 680 ohm 1/16W	for E2	R559	244 2055 996	Metal film 1.2 kohm 1W	
R409	963 9004 339	Carbon chip 470 ohm 1/16W		R565	244 2055 996	Metal film 1.2 kohm 1W	
R411	963 9005 011	Carbon chip 68 kohm 1/16W		R570	244 2055 996	Metal film 1.2 kohm 1W	
R412	963 9004 834	Carbon chip 5.6 kohm 1/16W		R651-656	963 9004 465	Carbon chip 75 ohm 1/16W	for E3,EU,E1,E1C,E1H,E1T
R413	960 9006 503	Metal film 220 ohm 1/4W		R657	963 9004 423	Carbon chip 68 ohm 1/10W	for E3,EU,E1,E1C,E1H,E1T
R414	963 9004 216	Carbon chip 2.2 kohm 1/16W		R658	963 9004 070	Carbon chip 10 kohm 1/16W	for E3,EU,E1,E1C,E1H,E1T
R415	963 9003 398	Carbon chip 1 kohm 1/16W		R660	963 9004 423	Carbon chip 68 ohm 1/10W	for E3,EU,E1,E1C,E1H,E1T
R416	963 9005 024	Metal film 680 ohm 1/4W		R661	963 9004 070	Carbon chip 10 kohm 1/16W	for E3,EU,E1,E1C,E1H,E1T
R417	963 9003 398	Carbon chip 1 kohm 1/16W		R663	963 9004 423	Carbon chip 68 ohm 1/10W	for E3,EU,E1,E1C,E1H,E1T
R418	963 9004 274	Carbon chip 33 kohm 1/16W		R664	963 9004 070	Carbon chip 10 kohm 1/16W	for E3,EU,E1,E1C,E1H,E1T
R420	963 9004 847	Carbon chip 3.3 kohm 1/16W		R666	963 9004 423	Carbon chip 68 ohm 1/10W	for E3,EU,E1,E1C,E1H,E1T
R426,427	963 9004 070	Carbon chip 10 kohm 1/16W		R667	963 9004 070	Carbon chip 10 kohm 1/16W	for E3,EU,E1,E1C,E1H,E1T
R428	963 9004 070	Carbon chip 10 kohm 1/16W	for E2	R671,672	963 9004 465	Carbon chip 75 ohm 1/16W	for E3,EU,E1,E1C,E1H,E1T
R428	963 9004 847	Carbon chip 3.3 kohm 1/16W	for E3,EU	R901,902	960 9009 270	Metal film 470 ohm 2W	
R428	963 9004 449	Carbon chip 6.8 kohm 1/16W	for E1,E1C,E1H,E1T	VR401	960 0096 606	Semi fixed resistor 20 kohm	
R429	963 9004 850	Carbon chip 82 ohm 1/16W		VR402	963 0056 205	Semi fixed resistor 50 kohm	for E3,EU,E1,E1C,E1H,E1T
R430	960 9003 807	Metal film 100 ohm 1/4W		VR402	960 0096 402	Semi fixed resistor 100 kohm	for E2
R431	963 9004 371	Carbon chip 5.1 kohm 1/16W		VR403	963 0052 005	Semi fixed resistor 200 kohm	
R432	963 9004 070	Carbon chip 10 kohm 1/16W		CAPACITORS GROUP			
R434	960 9003 807	Metal film 100 ohm 1/4W		C401,402	963 9004 685	Ceramic chip 1000pF/50V	
R435	963 9004 847	Carbon chip 3.3 kohm 1/16W		C403	963 9004 737	Ceramic chip 0.022uF/25V	
R437	963 9004 083	Carbon chip 100 kohm 1/16W		C404	963 9004 892	Ceramic 2pF/50V	
R438,439	963 9004 083	Carbon chip 100 kohm 1/16W	for E3,EU,E1,E1C,E1H,E1T	C405	963 9004 737	Ceramic chip 0.022uF/25V	
R438,439	963 9004 164	Carbon chip 150 kohm 1/16W	for E2	C406	963 9005 435	Ceramic chip 18pF/50V	
R440,441	963 9004 863	Carbon chip 120 kohm 1/16W	for E3,EU,E1,E1C,E1H,E1T	C408	960 9004 709	Ceramic 6pF/50V	
R440,441	963 9004 232	Carbon chip 220 kohm 1/16W	for E2	C409	963 9004 520	Ceramic 100pF/50V	
R442,443	963 9004 216	Carbon chip 2.2 kohm 1/16W	for E2	C410	963 9004 915	Ceramic 470pF/50V	
R442,443	963 9004 847	Carbon chip 3.3 kohm 1/16W	for E3,EU,E1,E1C,E1H,E1T	C411	963 9004 685	Ceramic chip 1000pF/50V	
R444,445	963 9004 847	Carbon chip 3.3 kohm 1/16W	for E2	C412	963 9004 737	Ceramic chip 0.022uF/25V	
R444,445	963 9004 481	Carbon chip 8.2 kohm 1/16W	for E3,EU,E1,E1C,E1H,E1T	C413	963 9004 575	Ceramic chip 100pF/50V	
R448	963 9004 216	Carbon chip 2.2 kohm 1/16W		C414		Electrolytic 2.2uF/50V	
R449	963 9005 037	Carbon chip 3.9 kohm 1/16W	for E2	C415		Electrolytic 47uF/10V	
R450	963 9003 398	Carbon chip 1 kohm 1/16W	for E2	C416		Electrolytic 10uF/35V	
R455	963 9004 876	Carbon chip 330 ohm 1/16W		C417		Electrolytic 100uF/16V	
R456	963 9003 385	Carbon chip 100 ohm 1/16W		C418	963 9004 698	Ceramic chip 0.01uF/50V	
R458,459	963 9004 342	Carbon chip 4.7 kohm 1/16W		C419		Electrolytic 10uF/35V	
R470	963 9003 398	Carbon chip 1 kohm 1/16W		C420,421	963 9004 591	Ceramic chip 22pF/50V	
R471VT	963 9004 203	Carbon chip 220 ohm 1/16W		C422	963 9004 656	Ceramic chip 470pF/50V	
R472	963 9003 385	Carbon chip 100 ohm 1/16W	for E2	C423,424	963 9004 737	Ceramic chip 0.022uF/25V	
R474	963 9004 889	Carbon chip 180 ohm 1/16W	for E2	C425		Electrolytic 4.7uF/50V	
R475	963 9004 122	Carbon chip 12 kohm 1/16W		C426		Electrolytic 3.3uF/50V	
R476	963 9004 397	Carbon chip 56 kohm 1/16W		C427		Electrolytic 4.7uF/50V	
R478	963 9004 070	Carbon chip 10 kohm 1/16W		C428	963 9004 737	Ceramic chip 0.022uF/25V	
R479	963 9004 083	Carbon chip 100 kohm 1/16W		C430	963 0021 900	Mylar film 0.047uF/200V	
R481C	963 9004 245	Carbon chip 2.2 Mohm 1/16W		C431	963 9004 627	Ceramic chip 33pF/50V	
R481FL,481FR	963 9004 245	Carbon chip 2.2 Mohm 1/16W		C432		Electrolytic 47uF/10V	
R481SL,481SR	963 9004 245	Carbon chip 2.2 Mohm 1/16W		C433	963 9004 737	Ceramic chip 0.022uF/25V	
R481SW	963 9004 245	Carbon chip 2.2 Mohm 1/16W		C434		Electrolytic 1uF/50V	for E3,EU
R482C	963 9003 385	Carbon chip 100 ohm 1/16W					
R482FL,482FR	963 9003 385	Carbon chip 100 ohm 1/16W					
R482SL,482SR	963 9003 385	Carbon chip 100 ohm 1/16W					
R482SW	963 9003 385	Carbon chip 100 ohm 1/16W					

Ref. No.	Part No.	Part Name	Remarks	Ref. No.	Part No.	Part Name	Remarks	Q'ty
C434		Electrolytic 0.33uF/50V	for E2,E1,E1C,E1H,E1T	C903		Electrolytic 1uF/50V		
C435,436	963 9004 737	Ceramic chip 0.022uF/25V		C904	960 9003 108	Ceramic 0.022uF/25V		
C437		Electrolytic 47uF/10V		OTHER PARTS GROUP				
C438		Electrolytic 1uF/50V		CF401	960 0187 104	FM ceramic filter SFE10.7MA8	for E3,EU,E1,E1C,E1H,E1T	1
C439		Electrolytic 0.22uF/50V		CF401	960 0177 509	FM ceramic filter SFE10.7MS3	for E2	1
C440,441		Electrolytic 1uF/50V		CF402	960 0187 104	FM ceramic filter SFE10.7MA8	for E3,EU	1
C442		Electrolytic 2.2uF/50V		CF402	960 0177 509	FM ceramic filter SFE10.7MS3	for E2,E1,E1C,E1H,E1T	1
C443		Electrolytic 10uF/35V		CF403	960 0187 609	Ceramic resonator BFU450C		1
C444		Electrolytic 4.7uF/50V		CN392	963 0086 000	2P connector cord	for E3,EU	1
C445		Electrolytic 10uF/35V		CN401	963 0046 503	10P connector base		1
C446,447	963 9004 931	Ceramic 180pF/50V	for E1,E1C,E1H,E1T	CN402	963 0049 607	15P connector base		1
C446,447	963 9005 448	Ceramic 330pF/50V	for E2	CN551	960 0124 604	14P connector base		1
C446,447	963 9005 053	Ceramic 270pF/50V	for E3,EU	CN552	963 0049 704	17P connector base		1
C448,449	963 9004 960	Ceramic 470pF/50V	for E3,EU	CN553	963 0049 801	20P connector base		1
C448,449	963 9004 960	Ceramic 470pF/50V	for E1,E1C,E1H,E1T	CN554	963 0090 708	14P connector cord		1
C450,451		Electrolytic 10uF/35V		CN601	963 0046 600	11P connector base		1
C453	963 9004 614	Ceramic chip 27pF/50V		CN651	963 0090 805	4P connector cord	for E3,EU,E1,E1C,E1H,E1T	1
C456	963 9004 672	Ceramic chip 680pF/50V		CN901	963 0090 902	3P connector cord		1
C461	963 9004 591	Ceramic chip 22pF/50V		CN931	963 0089 502	2P connector cord	for E2,E1,E1C,E1H,E1T	1
C462	963 9004 656	Ceramic chip 470pF/50V	for E2	CP302	963 0049 908	3P connector base		1
C463	963 9004 782	Mylar film 0.056uF/200V		CP392	963 0048 909	3P connector base	for E3,EU	1
C464	963 9004 973	Ceramic 3pF/50V		CP651	963 0050 104	4P connector base	for E3,EU,E1,E1C,E1H,E1T	1
C471VT		Electrolytic 1uF/50V		FE401	960 0187 706	FM tuner FTE4-401TB		1
C472VT	963 9004 753	Ceramic chip 0.047uF/50V		G401	—	1P lug wire L60 BK		1
C481C	963 9004 575	Ceramic chip 100pF/50V		G901	—	1P lug wire L80 BK		1
C481FL,481FR	963 9004 575	Ceramic chip 100pF/50V		JK901	960 0187 502	Headphone jack	for E3,EU,E2	1
C481SL,481SR	963 9004 575	Ceramic chip 100pF/50V		JK901	960 0176 306	Headphone jack	for E1,E1C,E1H,E1T	1
C481SW	963 9004 575	Ceramic chip 100pF/50V		L401	963 0052 102	Inductor 1uH		1
C551		Electrolytic 2.2uF/50V		L402	960 0010 307	Inductor 10uH		1
C551M		Electrolytic 100uF/35V		L403	963 0056 409	MW IF coil RBW07VB		1
C551S	963 9004 562	Ceramic 0.047uF/50V		SW391-397	963 0045 708	Tact switch		7
C552-554		Electrolytic 0.1uF/50V		SW601	963 0056 700	Slide switch	for E1,E1H,E1T	1
C555,556	963 9004 546	Ceramic 0.01uF/16V		SW901	960 0176 209	Push switch	for E3,EU	1
C557		Electrolytic 10uF/35V		SW901	963 0056 603	Push switch	for E2,E1,E1C,E1H,E1T	1
C601	963 9004 575	Ceramic chip 100pF/50V		T401	960 0007 323	MW IF coil PCFMAF-270		1
C602-604		Electrolytic 47uF/10V		T402	960 0007 349	FM IF coil M292MEA-K5611FKG		1
C605,606		Electrolytic 470uF/6.3V		T403	960 0007 352	FM IF coil 292MEA-K5612X		1
C607		Electrolytic 100uF/16V		T404,405	960 0071 207	MPX filter 253AGG-K5001-KR	for E2	2
C608	963 9004 575	Ceramic chip 100pF/50V	for E1,E1H,E1T	T406	960 0037 607	Antibirdie filter T126SE-K5256	for E2	1
C611	963 9004 698	Ceramic chip 0.01uF/50V		X401	960 0187 405	Crystal 7.2MHz		1
C612,613	963 9004 753	Ceramic chip 0.047uF/50V		X402	963 0043 302	Ceramic resonator CSB456F11		1
C651-653		Electrolytic 47uF/10V	for E3,EU,E1,E1C,E1H,E1T					
C654,655		Electrolytic 470uF/10V	for E3,EU,E1,E1C,E1H,E1T					
C656-658		Electrolytic 47uF/10V	for E3,EU,E1,E1C,E1H,E1T					
C659,660		Electrolytic 470uF/10V	for E3,EU,E1,E1C,E1H,E1T					
C661		Electrolytic 100uF/16V	for E3,EU,E1,E1C,E1H,E1T					
C662,663	963 9004 753	Ceramic chip 0.047uF/50V	for E3,EU,E1,E1C,E1H,E1T					
C664,665		Electrolytic 1uF/50V	for E3,EU,E1,E1C,E1H,E1T					
C901,902	963 9004 533	Ceramic 0.001uF/50V						

PRE-AMP P.W.B. ASS'Y

Ref. No.	Part No.	Part Name	Remarks	Q'ty
	960 0184 000	Bracket		2
	963 0054 003	Shield cover		1
	963 0088 406	Earth plate		1
	963 0052 403	3P Terminal		1
	960 0188 307	6P pin jack		1
	960 0194 508	1P pin jack		1
	960 0194 605	2P pin jack		1
	960 0188 404	3P pin jack		1
	960 0181 304	3P jack	for E3,EU,E1,E1C,E1H,E1T	1
	960 0181 401	DIN jack	for E3,EU,E1,E1C,E1H,E1T	1

Ref. No.	Part No.	Part Name	Remarks
SEMICONDUCTORS GROUP			
Q501C	960 0196 603	Transistor KTC2874B	
Q501FL,501FR	960 0196 603	Transistor KTC2874B	
Q501SL,501SR	960 0196 603	Transistor KTC2874B	
Q502C	960 0196 205	Transistor KSA992F	
Q502FL,502FR	960 0196 205	Transistor KSA992F	
Q502SL,502SR	960 0196 205	Transistor KSA992F	
Q503C	960 0196 205	Transistor KSA992F	
Q503FL,503FR	960 0196 205	Transistor KSA992F	
Q503SL,503SR	960 0196 205	Transistor KSA992F	
Q504C	960 0196 506	Transistor KSC1845F	
Q504FL,504FR	960 0196 506	Transistor KSC1845F	
Q504SL,504SR	960 0196 506	Transistor KSC1845F	
RESISTORS GROUP			
R509C	960 9005 902	Metal film 1.2 kohm 1/4W	
R509FL,509FR	960 9005 902	Metal film 1.2 kohm 1/4W	
R509SL,509SR	960 9005 902	Metal film 1.2 kohm 1/4W	
R511C	960 9004 301	Metal film 47 ohm 1/4W	
R511FL,511FR	960 9004 301	Metal film 47 ohm 1/4W	
R511SL,511SR	960 9004 301	Metal film 47 ohm 1/4W	
CAPACITORS GROUP			
C501C		Electrolytic 22uF/16V	
C501FL,501FR		Electrolytic 22uF/16V	
C501M		Electrolytic 10uF/35V	
C501SL,501SR		Electrolytic 22uF/16V	
C502C		Electrolytic 10uF/35V	
C502FL,502FR		Electrolytic 10uF/35V	
C502SL,502SR		Electrolytic 10uF/35V	
C503C	960 9003 165	Ceramic 220pF/500V	
C503FL,503FR	960 9003 165	Ceramic 220pF/500V	
C503SL,503SR	960 9003 165	Ceramic 220pF/500V	
C504C	963 9003 178	Ceramic 220pF/50V	
C504FL,504FR	963 9003 178	Ceramic 220pF/50V	
C504SL,504SR	963 9003 178	Ceramic 220pF/50V	
C505C	963 9003 181	Ceramic 33pF/500V	
C505FL,505FR	963 9003 181	Ceramic 33pF/500V	
C505SL,505SR	963 9003 181	Ceramic 33pF/500V	
C506C		Electrolytic 100uF/10V	
C506FL,506FR		Electrolytic 100uF/10V	
C506SL,506SR		Electrolytic 100uF/10V	
C507C	963 9003 194	Mylar film 0.0022uF/100V	
C507FL,507FR	963 9003 194	Mylar film 0.0022uF/100V	
C507SL,507SR	963 9003 194	Mylar film 0.0022uF/100V	
OTHER PARTS GROUP			
CN501	963 0046 406	9P connector base	1
CN502-504	963 0050 201	5P connector base	3
CN505	963 0050 308	6P connector base	1
CP554	963 0050 405	14P connector base	1
	960 0184 000	Bracket	2

DSP P.W.B. ASS'Y

Ref. No.	Part No.	Part Name	Remarks	Ref. No.	Part No.	Part Name	Remarks
SEMICONDUCTORS GROUP							
IC802	269 0186 002	Optical connector GP1FA502RZ		R855	963 9004 083	Carbon chip 100 kohm 1/16W	
IC803	963 0073 903	IC 74VHCU04		R856	963 9004 070	Carbon chip 10 kohm 1/16W	
IC805,806	963 0043 807	IC BA4510F		R859L,859R	963 9004 342	Carbon chip 4.7 kohm 1/16W	
IC807	963 0073 709	IC M27W201		R860L,860R	963 9004 342	Carbon chip 4.7 kohm 1/16W	
IC807S	963 0025 508	IC IC socket		R861	963 9004 326	Carbon chip 47 ohm 1/16W	
IC808,809	963 0074 407	IC MM74LCX574WMX		R861L,861R	963 9004 339	Carbon chip 470 ohm 1/16W	
IC810	960 0195 507	IC LC89055W(ES4)		R862L,862R	963 9004 342	Carbon chip 4.7 kohm 1/16W	
IC811	963 0074 805	IC RC1117S33ST		R863L,863R	963 9004 339	Carbon chip 470 ohm 1/16W	
IC812	963 0079 208	IC CS49326-CL		R864C	963 9004 083	Carbon chip 100 kohm 1/16W	
IC813	963 0074 601	IC AK4527B-VQ		R864FL,864FR	963 9004 083	Carbon chip 100 kohm 1/16W	
IC814-816	963 0024 004	IC NJM2068M		R864SL,864SR	963 9004 083	Carbon chip 100 kohm 1/16W	
IC817	269 0189 009	Optical connector GP1FA502TZ		R864SW	963 9004 083	Carbon chip 100 kohm 1/16W	
IC818,819	963 0074 203	IC MM74LCX244WMX		R866C	963 9004 342	Carbon chip 4.7 kohm 1/16W	
IC820	963 0074 708	IC RC1117S25T		R866FL,866FR	963 9004 342	Carbon chip 4.7 kohm 1/16W	
IC822	960 0195 109	IC SN74LV00APW		R866SL,866SR	963 9004 342	Carbon chip 4.7 kohm 1/16W	
IC828	963 0074 300	IC MM74HCT244WMX		R866SW	963 9004 342	Carbon chip 4.7 kohm 1/16W	
IC829	960 0196 001	IC NJM7805FA		R867C	963 9004 342	Carbon chip 4.7 kohm 1/16W	
IC830	963 0074 300	IC MM74HCT244WMX		R867FL,867FR	963 9004 342	Carbon chip 4.7 kohm 1/16W	
IC831	960 0195 303	IC SN74LV4040APWR		R867SL,867SR	963 9004 342	Carbon chip 4.7 kohm 1/16W	
IC832	963 0074 106	IC MM74HC151MX		R867SW	963 9004 342	Carbon chip 4.7 kohm 1/16W	
Q804C	960 0196 603	Transistor KTC2874B		R868C	963 9004 342	Carbon chip 4.7 kohm 1/16W	
Q804FL,804FR	960 0196 603	Transistor KTC2874B		R868FL,868FR	963 9004 342	Carbon chip 4.7 kohm 1/16W	
Q804SL,804SR	960 0196 603	Transistor KTC2874B		R868SL,868SR	963 9004 342	Carbon chip 4.7 kohm 1/16W	
Q804SW	960 0196 603	Transistor KTC2874B		R868SW	963 9004 342	Carbon chip 4.7 kohm 1/16W	
Q805	963 0075 105	Transistor DTC114EK		R869C	963 9004 342	Carbon chip 4.7 kohm 1/16W	
Q806	963 0058 203	Transistor DTA114EK		R869FL,869FR	963 9004 342	Carbon chip 4.7 kohm 1/16W	
Q807,808	963 0075 105	Transistor DTC114EK		R869SL,869SR	963 9004 342	Carbon chip 4.7 kohm 1/16W	
D801	960 0197 000	Diode KDS160		R869SW	963 9004 342	Carbon chip 4.7 kohm 1/16W	
D806,807	960 0197 000	Diode KDS160		R870C	963 9003 398	Carbon chip 1 kohm 1/16W	
RESISTORS GROUP							
R801	963 9004 342	Carbon chip 4.7 kohm 1/16W		R870FL,870FR	963 9003 398	Carbon chip 1 kohm 1/16W	
R803	963 9004 342	Carbon chip 4.7 kohm 1/16W		R870SL,870SR	963 9003 398	Carbon chip 1 kohm 1/16W	
R804,805	963 9003 385	Carbon chip 100 ohm 1/16W		R870SW	963 9003 398	Carbon chip 1 kohm 1/16W	
R808	963 9004 274	Carbon chip 33 kohm 1/16W		R871C	963 9004 083	Carbon chip 100 kohm 1/16W	
R817-825	963 9004 070	Carbon chip 10 kohm 1/16W		R871FL,871FR	963 9004 083	Carbon chip 100 kohm 1/16W	
R830	963 9004 342	Carbon chip 4.7 kohm 1/16W		R871SL,871SR	963 9004 083	Carbon chip 100 kohm 1/16W	
R831	963 9004 070	Carbon chip 10 kohm 1/16W		R871SW	963 9004 083	Carbon chip 100 kohm 1/16W	
R834,835	963 9004 342	Carbon chip 4.7 kohm 1/16W		R872C	963 9004 216	Carbon chip 2.2 kohm 1/16W	
R836	963 9004 070	Carbon chip 10 kohm 1/16W		R872FL,872FR	963 9004 216	Carbon chip 2.2 kohm 1/16W	
R838	963 9004 070	Carbon chip 10 kohm 1/16W		R872SL,872SR	963 9004 216	Carbon chip 2.2 kohm 1/16W	
R839	963 9004 342	Carbon chip 4.7 kohm 1/16W		R872SW	963 9004 216	Carbon chip 2.2 kohm 1/16W	
R841	963 9004 339	Carbon chip 470 ohm 1/16W		R880,881	963 9004 326	Carbon chip 47 ohm 1/16W	
R842	963 9004 342	Carbon chip 4.7 kohm 1/16W		R911	963 9004 070	Carbon chip 10 kohm 1/16W	
R845R	963 9004 355	Carbon chip 47 kohm 1/16W		R913	963 9004 096	Carbon chip 1 Mohm 1/16W	
R848	963 9003 385	Carbon chip 100 ohm 1/16W		R922	963 9004 342	Carbon chip 4.7 kohm 1/16W	
R850	963 9004 465	Carbon chip 75 ohm 1/16W		R923	963 9004 410	Carbon chip 6.2 kohm 1/16W	
R854	963 9004 216	Carbon chip 2.2 kohm 1/16W		R927	963 9004 465	Carbon chip 75 ohm 1/16W	
R854L	963 9004 355	Carbon chip 47 kohm 1/16W		R928	963 9004 371	Carbon chip 5.1 kohm 1/16W	
				R929	963 9004 481	Carbon chip 8.2 kohm 1/16W	
				R930	963 9004 261	Carbon chip 3 kohm 1/16W	
				R931	963 9004 410	Carbon chip 6.2 kohm 1/16W	
				R931L,931R	963 9004 177	Carbon chip 18 kohm 1/16W	

Ref. No.	Part No.	Part Name	Remarks	Ref. No.	Part No.	Part Name	Remarks
R932	963 9004 342	Carbon chip 4.7 kohm 1/16W		C873FL,873FR	963 9004 672	Ceramic chip 680pF/50V	
R938	963 9004 368	Carbon chip 470 kohm 1/16W		C873SL,873SR	963 9004 672	Ceramic chip 680pF/50V	
R940	963 9004 070	Carbon chip 10 kohm 1/16W		C873SW	963 9004 672	Ceramic chip 680pF/50V	
R949	963 9004 326	Carbon chip 47 ohm 1/16W		C874C	963 9004 672	Ceramic chip 680pF/50V	
R952,953	963 9003 385	Carbon chip 100 ohm 1/16W		C874FL,874FR	963 9004 672	Ceramic chip 680pF/50V	
CAPACITORS GROUP				C874SL,874SR	963 9004 672	Ceramic chip 680pF/50V	
C801	963 9004 711	Ceramic chip 0.1uF/50V		C874SW	963 9004 672	Ceramic chip 680pF/50V	
C802,803	963 9004 591	Ceramic chip 22pF/50V		C875C		Electrolytic 10uF/35V	
C805	963 9004 591	Ceramic chip 22pF/50V		C875FL,875FR		Electrolytic 10uF/35V	
C808	963 9004 711	Ceramic chip 0.1uF/50V		C875SL,875SR		Electrolytic 10uF/35V	
C809		Electrolytic 47uF/10V		C875SW		Electrolytic 10uF/35V	
C810	963 9004 711	Ceramic chip 0.1uF/50V		C876C	963 9004 740	Ceramic chip 3300pF/50V	
C811		Electrolytic 47uF/10V		C876FL,876FR	963 9004 740	Ceramic chip 3300pF/50V	
C812	963 9004 711	Ceramic chip 0.1uF/50V		C876SL,876SR	963 9004 740	Ceramic chip 3300pF/50V	
C813		Electrolytic 47uF/10V		C876SW	963 9004 740	Ceramic chip 3300pF/50V	
C814	963 9004 591	Ceramic chip 22pF/50V		C880C		Electrolytic 10uF/35V	
C815	963 9004 711	Ceramic chip 0.1uF/50V		C880FL,880FR		Electrolytic 10uF/35V	
C816	963 9004 591	Ceramic chip 22pF/50V		C880SL,880SR		Electrolytic 10uF/35V	
C817	963 9004 711	Electrolytic 0.1uF/50V		C880SW		Electrolytic 10uF/35V	
C818	963 9004 711	Ceramic chip 0.1uF/50V		C908,909	963 9004 614	Ceramic chip 27pF/50V	
C819,820		Electrolytic 47uF/10V		C916	963 9004 711	Ceramic chip 0.1uF/50V	
C821		Electrolytic 100uF/10V		C917		Electrolytic 10uF/35V	
C822,823	963 9004 711	Ceramic chip 0.1uF/50V		C918	963 9004 711	Ceramic chip 0.1uF/50V	
C824		Electrolytic 47uF/10V		C919	963 9004 698	Ceramic chip 0.01uF/50V	
C825		Electrolytic 1uF/50V		C920	963 9004 711	Ceramic chip 0.1uF/50V	
C826		Electrolytic 10uF/35V		C921	963 9004 698	Ceramic chip 0.01uF/50V	
C827	963 9004 711	Ceramic chip 0.1uF/50V		C923	963 9004 711	Ceramic chip 0.1uF/50V	
C828	963 9004 698	Ceramic chip 0.01uF/50V		C925	963 9004 711	Ceramic chip 0.1uF/50V	
C829		Electrolytic 10uF/35V		C926		Electrolytic 10uF/35V	
C830-832	963 9004 711	Ceramic chip 0.1uF/50V		C931	963 9004 698	Ceramic chip 0.01uF/50V	
C833	963 9004 656	Ceramic chip 470pF/50V		C936	963 9004 711	Ceramic chip 0.1uF/50V	
C834		Electrolytic 10uF/35V		C937		Electrolytic 10uF/35V	
C835		Electrolytic 1uF/50V		C938		Electrolytic 1uF/50V	
C836		Electrolytic 220uF/6.3V		C939,940	963 9004 698	Ceramic chip 0.01uF/50V	
C837,838	963 9004 711	Ceramic chip 0.1uF/50V		C943	963 9004 711	Electrolytic 0.1uF/50V	
C839	963 9004 698	Ceramic chip 0.01uF/50V		C944	963 9004 698	Ceramic chip 0.01uF/50V	
C840		Electrolytic 2.2uF/50V		C946,947	963 9004 711	Ceramic chip 0.1uF/50V	
C841		Electrolytic 47uF/10V		C948		Electrolytic 10uF/35V	
C842	963 9004 711	Ceramic chip 0.1uF/50V		C949		Electrolytic 2.2uF/50V	
C844	963 9004 711	Ceramic chip 0.1uF/50V		C950	963 9004 711	Ceramic chip 0.1uF/50V	
C845	963 9004 698	Ceramic chip 0.01uF/50V		C951		Electrolytic 100uF/10V	
C849	963 9004 698	Ceramic chip 0.01uF/50V		C952,953	963 9004 711	Ceramic chip 0.1uF/50V	
C851	963 9004 698	Ceramic chip 0.01uF/50V		C954	963 9004 698	Ceramic chip 0.01uF/50V	
C854,855		Electrolytic 100uF/25V		C956	963 9004 685	Ceramic chip 1000pF/50V	
C856-863	963 9004 711	Ceramic chip 0.1uF/50V		C957	963 9004 711	Ceramic chip 0.1uF/50V	
C864L,864R		Electrolytic 10uF/35V		C958		Electrolytic 100uF/10V	
C865L,865R	963 9004 575	Ceramic chip 100pF/50V					
C866	963 9004 698	Ceramic chip 0.01uF/50V					
C869L,869R	963 9004 575	Ceramic chip 100pF/50V					
C871L,871R	963 9004 685	Ceramic chip 1000pF/50V					
C873C	963 9004 672	Ceramic chip 680pF/50V					

Note : The symbols in the column "Remarks" indicate the following destinations.
 E1 : Asia model
 E1H : Hong Kong model
 E1T : Taiwan R.O.C. model

VOLTAGE SEL. P.W.B. ASS'Y
 (for Asia, Hong Kong & Taiwan R.O.C. model)

Ref. No.	Part No.	Part Name	Remarks	Q'ty	Ref. No.	Part No.	Part Name	Remarks	Q'ty
OTHER PARTS GROUP					OTHER PARTS GROUP				
CB801	963 0050 502	Chip beads HB-IT2012		1	CN105	963 0059 105	2P connector cord	for E1,E1H,E1T	1
CB803-808	963 0050 502	Chip beads HB-IT2012		6	CN903	963 0058 805	2P connector cord	for E1,E1H,E1T	1
CB828	963 0050 502	Chip beads HB-IT2012		1	CP901	963 0061 203	5P connector base	for E1,E1H,E1T	1
CN801,802	963 0049 704	17P connector base		2	CP902	963 0059 309	3P connector cord	for E1,E1H,E1T	1
CN803	963 0046 309	8P connector base		1	△ F101	960 0142 602	Fuse 250V-T2.5A	for E1,E1H,E1T	1
JACK801	963 0052 500	1P pin jack		1	F101A,101B	960 0005 804	Fuse clip	for E1,E1H,E1T	2
L801,802	963 0050 803	Inductor 4.7uH		2	△ F102	963 0044 709	Fuse 250V-T3.15A	for E1,E1H,E1T	1
L803	963 0050 900	Inductor 2.2uH		1	F102A,102B	960 0005 804	Fuse clip	for E1,E1H,E1T	2
L805,806	963 0050 803	Inductor 4.7uH		2	△ F901	963 0057 107	Fuse 250V-T6.3A	for E1,E1H,E1T	1
L807	963 0050 900	Inductor 2.2uH		1	F901A,901B	960 0005 804	Fuse clip	for E1,E1H,E1T	2
XTAL801	960 0180 907	Crystal 12.288MHz		1	JK911	960 0143 203	AC outlet	for E1,E1H,E1T	1
					JK912	963 0056 904	Slide switch	for E1,E1H,E1T	1
							P.C. supporter	for E1,E1H,E1T	2
							Card spacer	for E1,E1H,E1T	1

EXPLODED VIEW

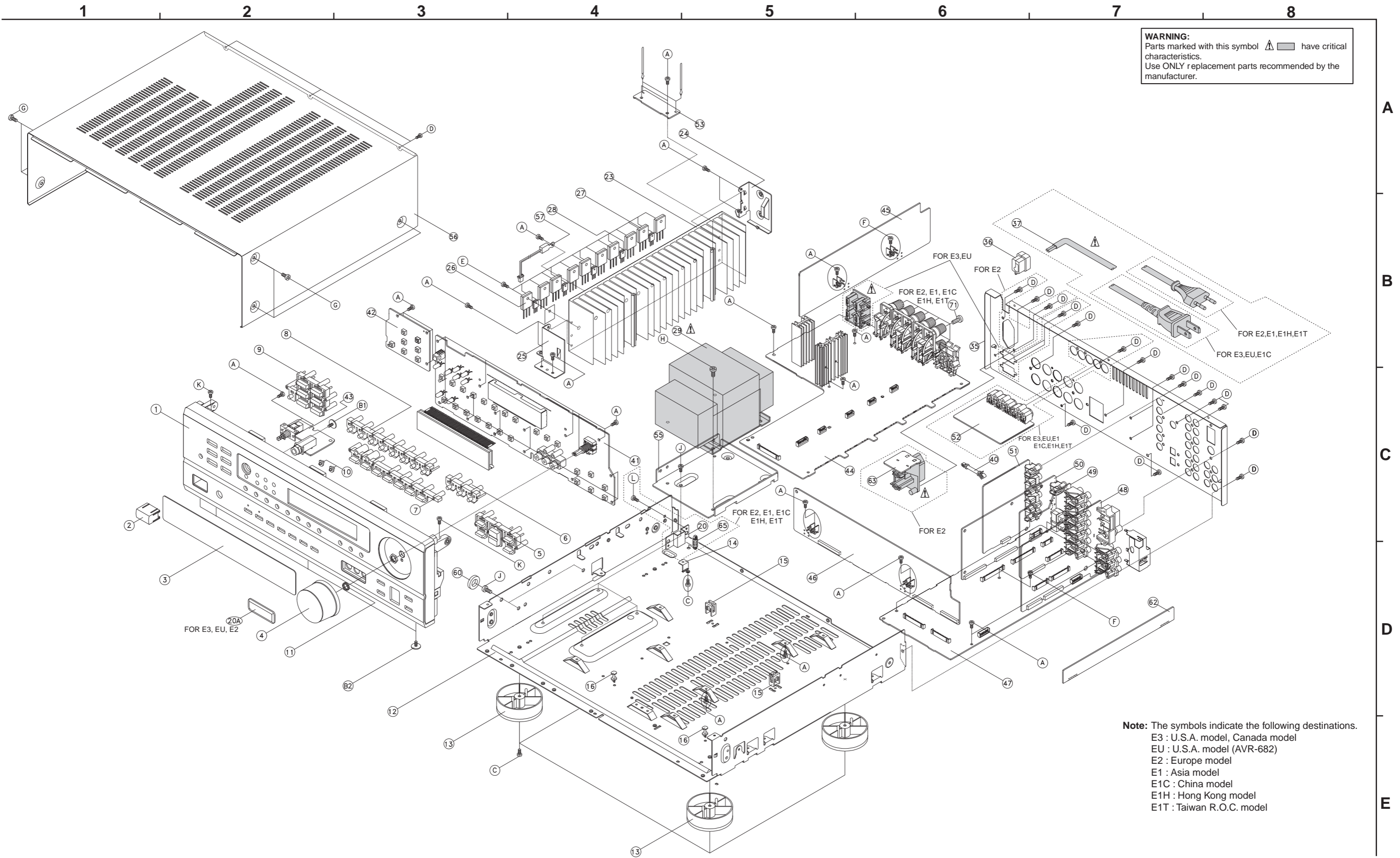

WARNING:
 Parts marked with this symbol  have critical characteristics.
 Use ONLY replacement parts recommended by the manufacturer.

Note: The symbols indicate the following destinations.
 E3 : U.S.A. model, Canada model
 EU : U.S.A. model (AVR-682)
 E2 : Europe model
 E1 : Asia model
 E1C : China model
 E1H : Hong Kong model
 E1T : Taiwan R.O.C. model

Note : The symbols in the column "Remarks" indicate the following destinations.
 E3: U.S.A. & Canada model EU: U.S.A. model (AVR-682)
 E2: Europe model E1: Asia model
 E1C: China model E1H: Hong Kong model
 E1T: Taiwan R.O.C. model

PARTS LIST OF EXPLODED VIEW

Ref. No.	Part No.	Part Name	Remarks	Q'ty	Ref. No.	Part No.	Part Name	Remarks	Q'ty	
41F	963 0073 149	CPU P.W.B. Ass'y	for E3,EU	1	8	960 0192 102	8 key button	for gold model	1	
41F	963 0073 136	CPU P.W.B. Ass'y	for E2	1	9	963 0076 803	7 key button (B)	for black model	1	
41F	963 0073 110	CPU P.W.B. Ass'y	for E1,E1H,E1T	1	9	963 0072 603	7 key button (B)	for gold model	1	
41F	963 0073 123	CPU P.W.B. Ass'y	for E1C	1	10	960 0191 417	LED lens		2	
41		Front P.W.B.			11	963 0051 006	Knob spring		1	
47		CPU P.W.B.			12	960 0198 229	Main chassis		1	
53		Video CNT P.W.B.	for E3,EU,E1,E1C,E1H,E1T		13	960 0183 904	Foot		4	
63		Outlet P.W.B.	for E2		14	960 0184 107	Supporter bracket		1	
42F	963 0073 246	CNT P.W.B. Ass'y	for E3,EU	1	15	960 0003 301	PWB supporter		2	
42F	963 0073 233	CNT P.W.B. Ass'y	for E2	1	16	963 0051 103	Card spacer		2	
42F	963 0073 217	CNT P.W.B. Ass'y	for E1,E1H,E1T	1	20	963 0081 607	Side bracket	for E2,E1,E1C,E1H,E1T	1	
42F	963 0073 220	CNT P.W.B. Ass'y	for E1C	1	20A	963 0090 300	Pin jack cover	for E3,EU,E2	1	
42		Switch P.W.B.			23	—	Heat sink		1	
43		Headphone P.W.B.			24	960 0184 204	Heat sink bracket B		1	
46		CNT P.W.B.			25	960 0184 301	Heat sink bracket F		1	
48		Tuner P.W.B.			26	960 0090 107	Transistor 2SB1599Y	Q102C,102FL,102FR, 102SL,102SR	5	
51		Video P.W.B.			27	960 0090 000	Transistor 2SD2389Y	Q101C,101FL,101FR, 101SL,101SR	5	
52		S-Video P.W.B.	for E3,EU,E1,E1C,E1H,E1T		28	963 0058 106	Transistor 2SD947F	Q103C,103FL,103FR, 103SL,103SR	5	
44F	963 0073 042	Main P.W.B. Ass'y	for E3,EU	1	△	29	963 0090 245	Power trans	for E3,EU	1
44F	963 0073 039	Main P.W.B. Ass'y	for E2	1	△	29	963 0090 232	Power trans	for E2	1
44F	963 0073 013	Main P.W.B. Ass'y	for E1,E1H,E1T	1	△	29	963 0090 216	Power trans	for E1,E1H,E1T	1
44F	963 0073 026	Main P.W.B. Ass'y	for E1C	1	△	29	963 0090 229	Power trans	for E1C	1
44		Main P.W.B.			35	963 0072 137	Back chassis	for E3	1	
49		Input P.W.B.			35	963 0072 140	Back chassis	for EU	1	
62		Front CNT P.W.B.			35	963 0072 124	Back chassis	for E2	1	
45F	963 0073 343	Pre-amp P.W.B. Ass'y	for E3,EU	1	35	963 0072 111	Back chassis	for E1,E1H,E1T	1	
45F	963 0073 330	Pre-amp P.W.B. Ass'y	for E2	1	35	963 0072 153	Back chassis	for E1C	1	
45F	963 0073 314	Pre-amp P.W.B. Ass'y	for E1,E1H,E1T	1	36	960 0192 403	AC cord stopper		1	
45F	963 0073 327	Pre-amp P.W.B. Ass'y	for E1C	1	△	37	960 0166 400	AC cord	for E3,EU	1
45		Pre-amp P.W.B.			△	37	960 0202 500	AC cord	for E2	1
50F	963 0073 440	DSP P.W.B. Ass'y	for E3,EU	1	△	37	963 0060 408	AC cord	for E1,E1T	1
50F	963 0073 437	DSP P.W.B. Ass'y	for E2	1	△	37	963 0063 301	AC cord	for E1C	1
50F	963 0073 411	DSP P.W.B. Ass'y	for E1,E1H,E1T	1	△	37	960 0143 009	AC cord	for E1H	1
50F	963 0073 424	DSP P.W.B. Ass'y	for E1C	1		40	963 0061 902	Fastener		1
50		DSP P.W.B.				55	963 0072 205	Trans bracket		1
64F	963 0079 004	Voltage sel. P.W.B. Ass'y	for E1,E1H,E1T	1		56	963 0053 017	Top cover	for black model	1
64		Voltage sel. P.W.B.	for E1,E1H,E1T			56	960 0191 019	Top cover	for gold model	1
1	963 0072 056	Front panel	for E3	1		57	960 0187 900	Posistor		1
1	963 0072 027	Front panel	for EU	1		60	963 0072 302	Rubber cushion		2
1	963 0072 030	Front panel	for E2	1		65	963 0044 602	P.C. supporter	for E2,E1,E1C,E1H,E1T	1
1	963 0072 014	Front panel	for E1,E1C,E1H,E1T	1		71	960 0093 104	Terminal bushing	for E2,E1,E1C,E1H,E1T	10
2	960 0185 009	Power button	for black model	1	★	72	960 0155 301	Wire clamp band		3
2	960 0191 705	Power button	for gold model	1	★	73	963 0054 207	Fuse caution label	for E3,EU	1
3	963 0072 412	Display window		1	★	74	963 0076 007	15P FCC		1
4	963 0054 906	Volume knob	for black model	1						
4	960 0191 608	Volume knob	for gold model	1						
5	963 0053 703	5 key button	for black model	1						
5	960 0191 802	5 key button	for gold model	1						
6	963 0053 606	3 key button	for black model	1						
6	960 0192 209	3 key button	for gold model	1						
7	963 0076 706	7 key button (A)	for black model	1						
7	963 0072 506	7 key button (A)	for gold model	1						
8	963 0053 509	8 key button	for black model	1						

Ref. No.	Part No.	Part Name	Remarks	Q'ty
SCREWS				
A	963 0018 007	Screw 3x8 CBTS(B)-Z	for E3,EU,E1,E1C,E1H,E1T	46
A	963 0018 007	Screw 3x8 CBTS(B)-Z	for E2	44
B1	960 9008 420	Screw 3x8 CBTS(B) W-Z	for black model	1
B1	960 9008 420	Screw 3x8 CBTS(B) W-Z	for gold model	5
B2	960 9008 527	Screw 3x8 CBTS(B) W-B	for black model	4
C	963 0048 200	Screw 3x10 CBTS(B)-Z		5
D	960 0108 714	Screw 3x10 CBTS(B) DOT-B	for E3,EU	32
D	960 0108 714	Screw 3x10 CBTS(B) DOT-B	for E2	29
D	960 0108 714	Screw 3x10 CBTS(B) DOT-B	for E1,E1T	34
D	960 0108 714	Screw 3x10 CBTS(B) DOT-B	for E1C,E1H	30
E	963 9004 009	Screw 3x14 CHTS(B) SW W-Z		15
F	963 0018 104	Screw 3x17 CBTS(B)-Z	for E3,EU,E2,E1,E1H,E1T	4
F	963 0018 104	Screw 3x17 CBTS(B)-Z	for E1C	2
G	963 0048 307	Screw 4x8 CBTS(B) DOT-B	for black model	6
G	963 9004 012	Screw 4x8 CBTS(B) DOT-Ni	for gold model	6
H	960 9008 417	Screw 4x8 CBTS SW W-Z		4
J	963 9004 025	Screw 4x6 CBTS(S)-Z		6
K	963 9004 038	Screw 3x8 CBTS(B) W-Z		2
L	963 9004 041	Screw 3x5 CBTS(B)-Z	for E2,E1,E1C,E1H,E1T	2

PACKING VIEW

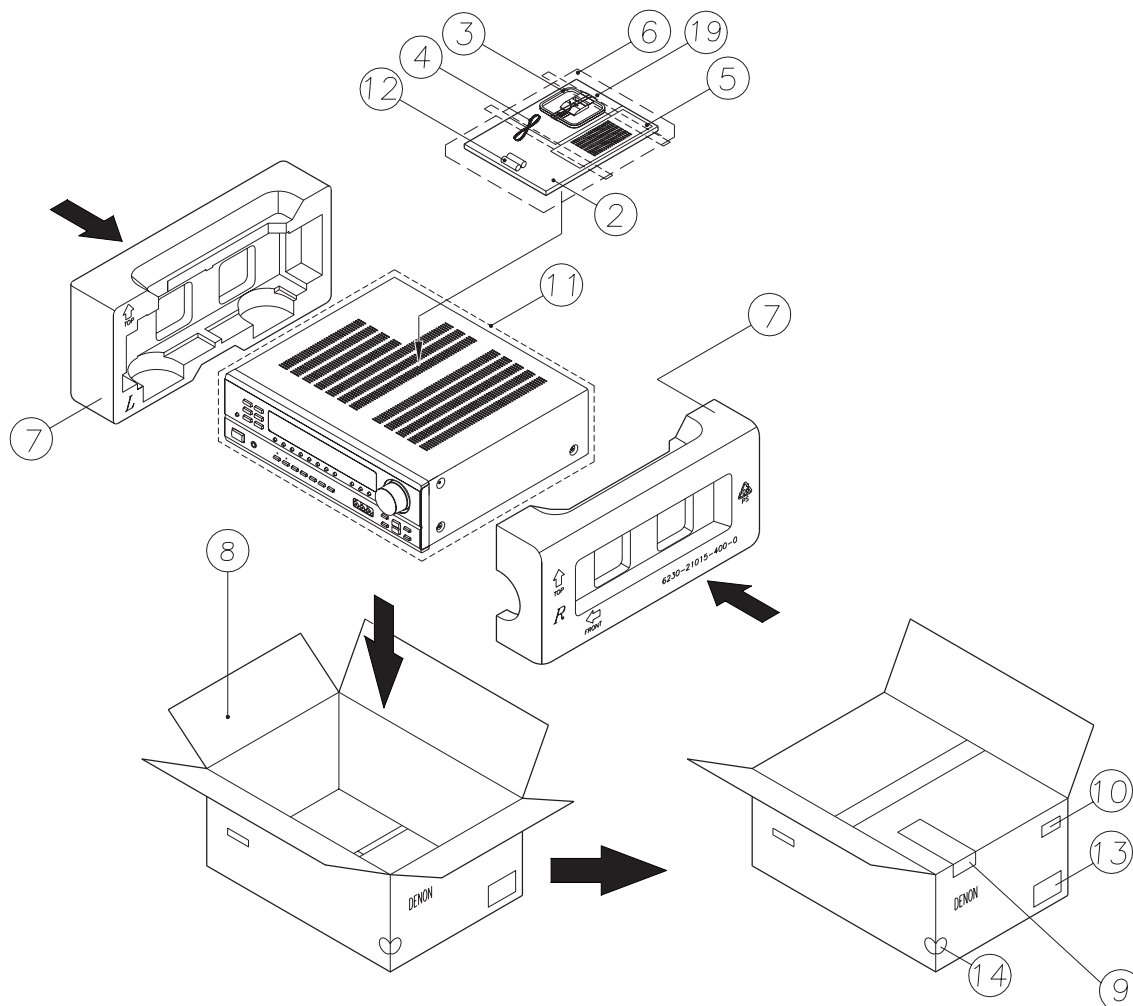

Note : The symbols in the column "Remarks" indicate the following destinations.
 E3: U.S.A. & Canada model EU: U.S.A. model (AVR-682)
 E2: Europe model E1: Asia model
 E1C: China model
 E1T: Taiwan R.O.C. model

PARTS LIST OF PACKING & ACCESSORIES

Ref. No.	Part No.	Part Name	Remarks	Q'ty	Ref. No.	Part No.	Part Name	Remarks	Q'ty
	2	963 0072 836	Instruction manual	for E3,EU	1	12	—	Battery (R6P/AA)	2
	2	963 0072 823	Instruction manual	for E2	1	13	960 0092 901	Control card	2
	2	963 0072 810	Instruction manual	for E1,E1C,E1H,E1T	1	14	—	Color label (gold)	for gold model 2
	3	963 0052 306	Loop antenna		★ 16	515 0867 101	Service station list (EX)		1
	4	963 0052 209	FM antenna		★ 21	—	RDS label	for E2	2
	5	963 0076 900	Remote controller RC-896		★ 22	513 3342 009	Carton label (B)	for E1,E1C,E1H,E1T	1
	6	963 0045 106	Poly. bag		★ 23	513 3341 000	Carton label (A)	for E1,E1C,E1H,E1T	1
	7	960 0193 101	Cushion		★ 24	513 3340 001	Label (A)	for E1,E1H	1
★ 7A	963 0055 918	Pad	for E1H	2	★ 25	963 0025 809	Preset label	for E1,E1H,E1T	1
8	963 0072 933	Carton case	for E3,E2	1	★ 26	513 3331 007	DTS label	for E1,E1H,E1T	1
8	963 0072 959	Carton case	for EU	1	★ 27	—	CCIB label	for E1C	1
8	963 0072 917	Carton case	for E1,E1C,E1T	1	★ 28	—	Box label (gold)	for E1C	1
8	963 0072 920	Carton case	for E1H	1	★ 29	513 2481 000	Serial no. label (T)	for E1T	1
9	515 0866 005	Warranty card	for E3,EU	1	★ 30	—	Caution label	for E1T	1
9A	—	Envelope (warranty)	for E3,EU	1	★ 31	—	Kolin label (rating)	for E1T	1
10	—	UPC label	for E3	1	★ 32	—	Kolin label (box)	for E1T	1
10	—	UPC label	for EU	1	★ 33	960 0185 300	Registration card	for E3,EU	1
10	—	POS label	for E2	1	★ 35	963 0061 300	AC adapter	for E1,E1C,E1T	1
11	960 0185 601	Poly. bag	for set	1					

WIRING DIAGRAM

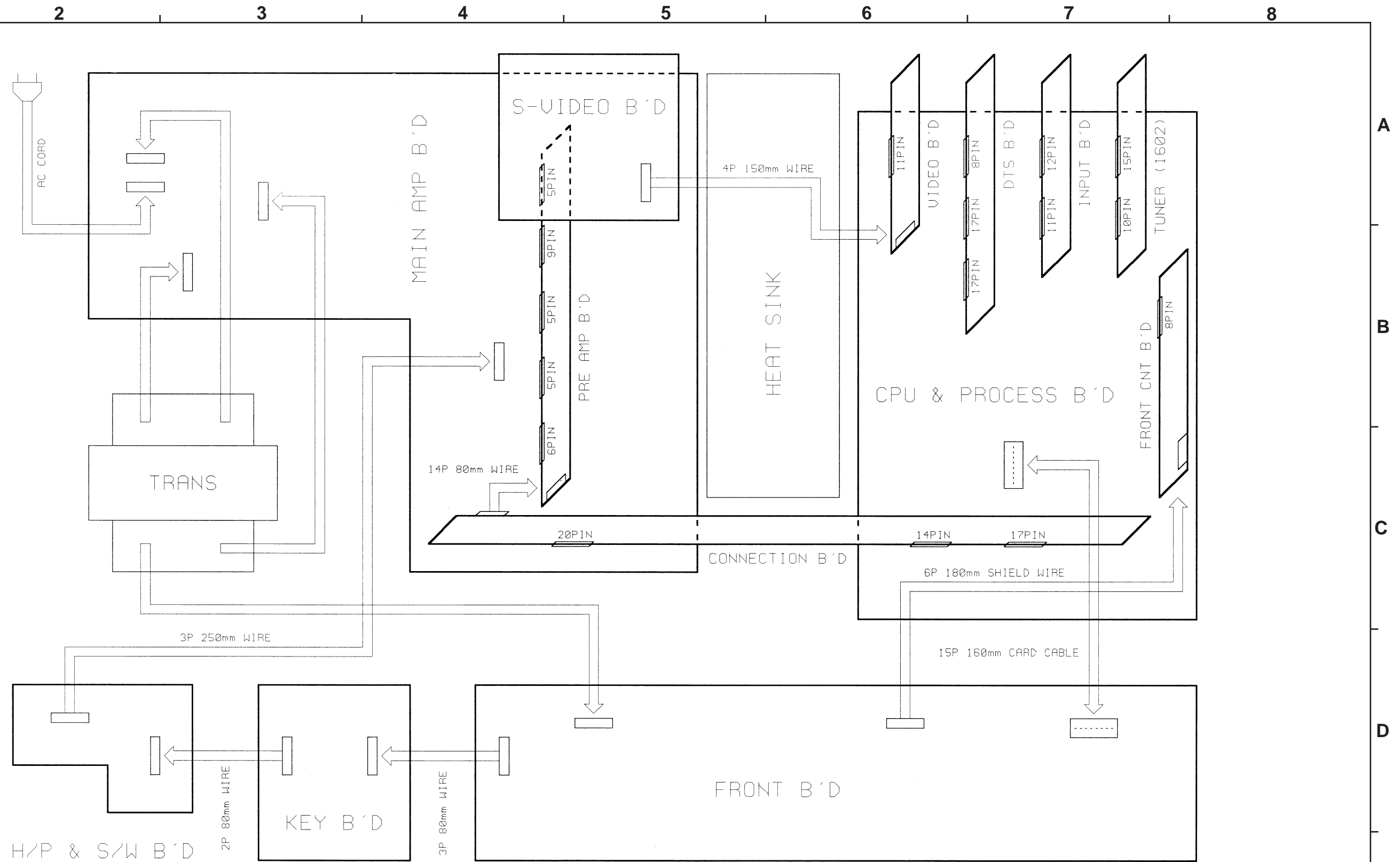

AVR-1602 WIRING DIAGRAM

SCHEMATIC DIAGRAMS(1/7)

1 2 3 4 5 6 7 8 9 10 11

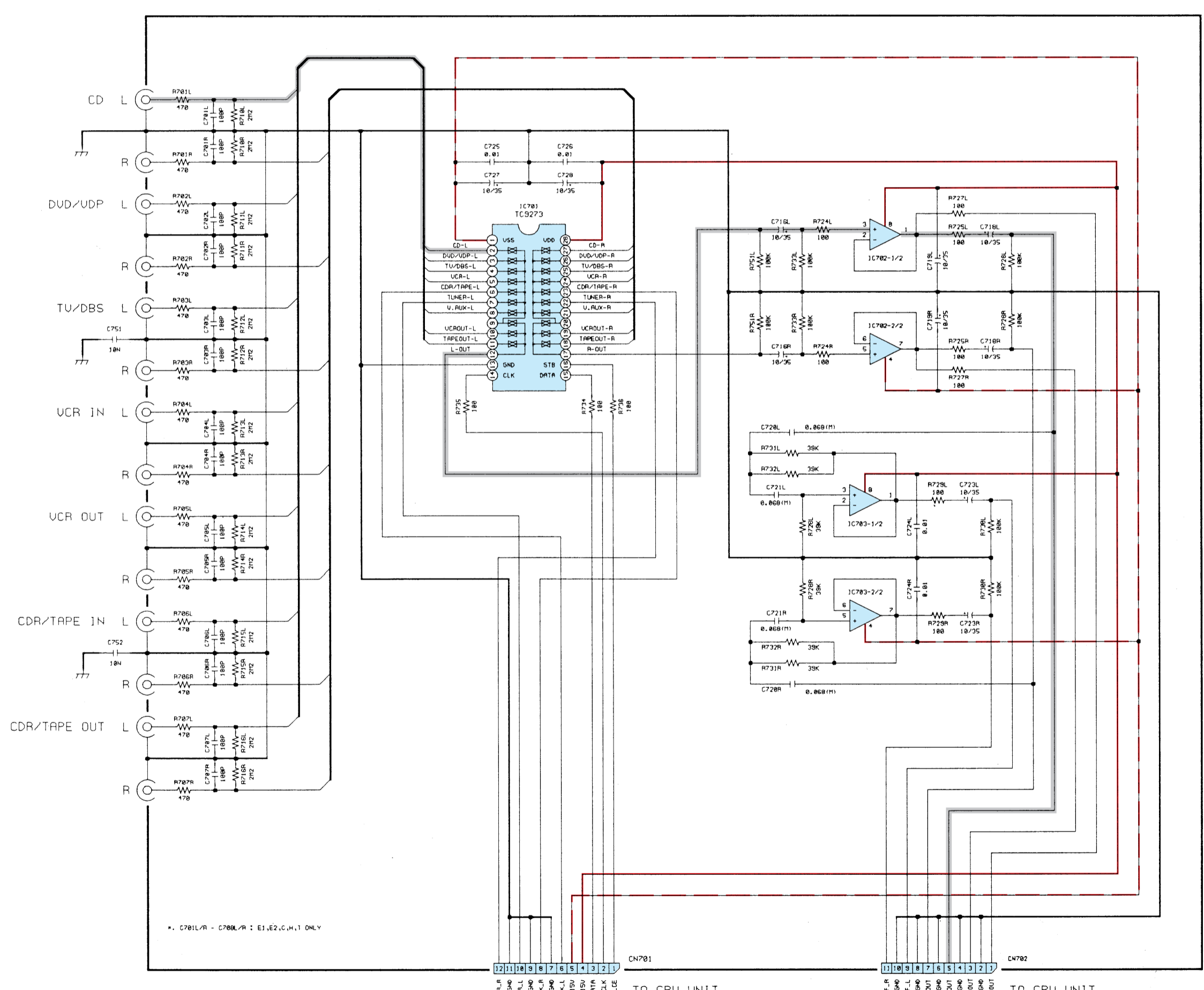
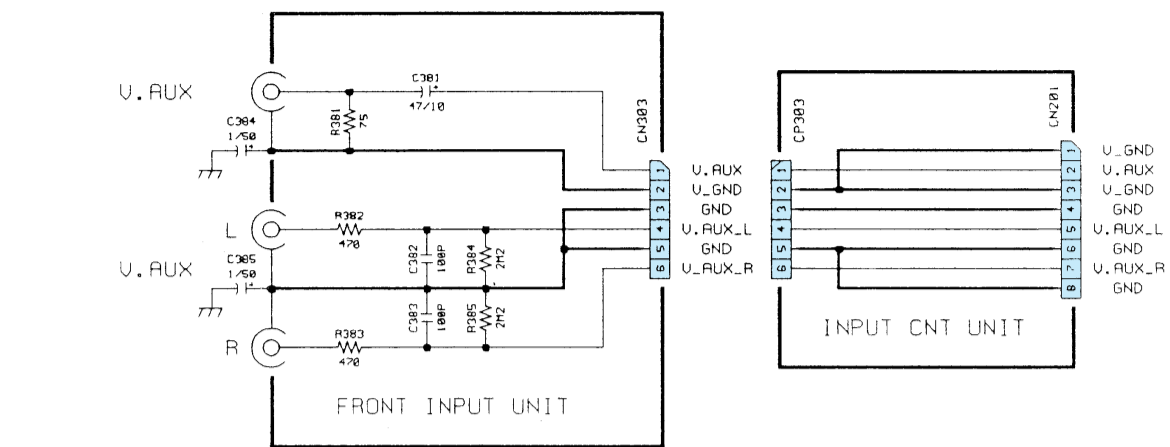

NOTICE
 ALL RESISTANCE VALUES IN OHM. k=1,000 OHM M=1,000,000 OHM
 ALL CAPACITANCE VALUES IN MICRO FARAD. P=MICRO-MICRO FARAD
 EACH VOLTAGE AND CURRENT ARE MEASURED AT NO SIGNAL INPUT
 CONDITION.
 CIRCUIT AND PARTS ARE SUBJECT TO CHANGE WITHOUT PRIOR
 NOTICE.

WARNING:
 Parts marked with this symbol Δ have critical characteristics.
 Use ONLY replacement parts recommended by the manufacture.

CAUTION:
 Before returning the unit to the customer, make sure you make either (1) a
 leakage current check or (2) a line to chassis resistance check. If the leakage
 current exceeds 0.5 milliamps, or if the resistance from chassis to either side
 of the power card is less than 460kohms, the unit is defective.

WARNING:
 DO NOT return the unit to the customer until the problem is located and
 corrected.

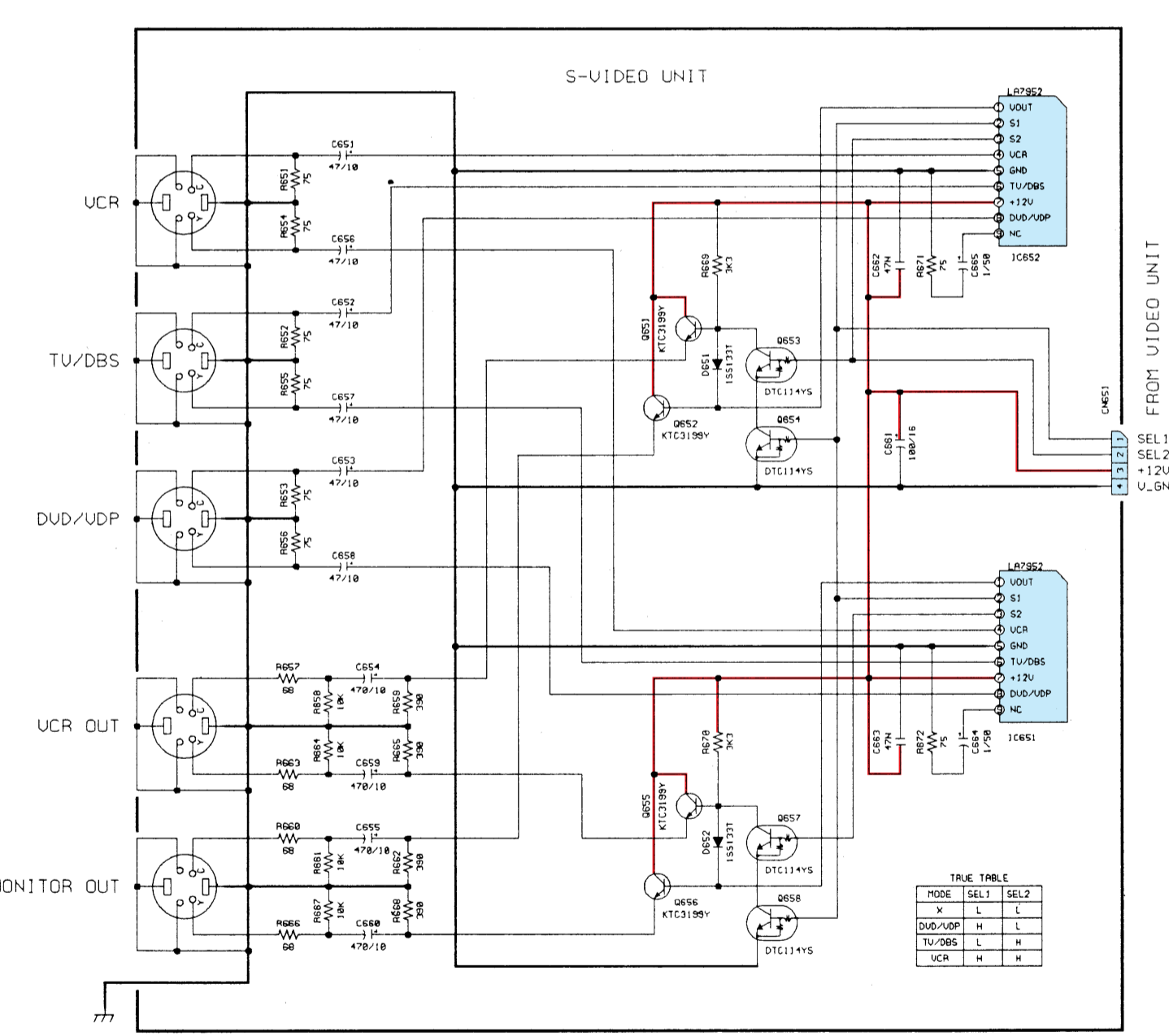
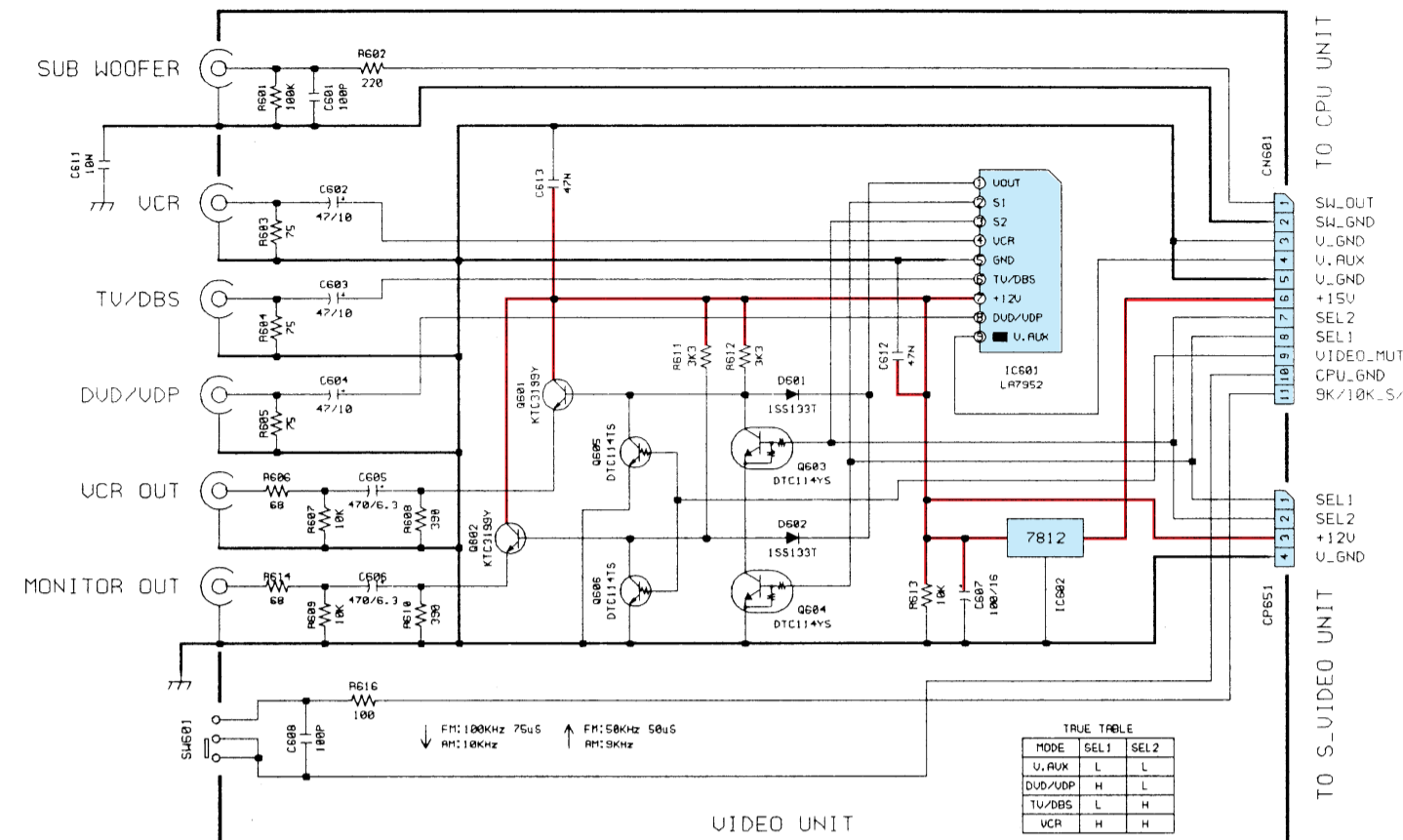

— + B LINE
 - - - - - B LINE
 ——— SIGNAL LINE

SCHEMATIC DIAGRAMS(1/7)
 INPUT P.W.B. UNIT
 VIDEO P.W.B. UNIT
 S-VIDEO P.W.B. UNIT
 FRONT INPUT P.W.B. UNIT
 INPUT CNT P.W.B. UNIT

SCHEMATIC DIAGRAMS(1/7)

1 2 3 4 5 6 7 8 9 10 11

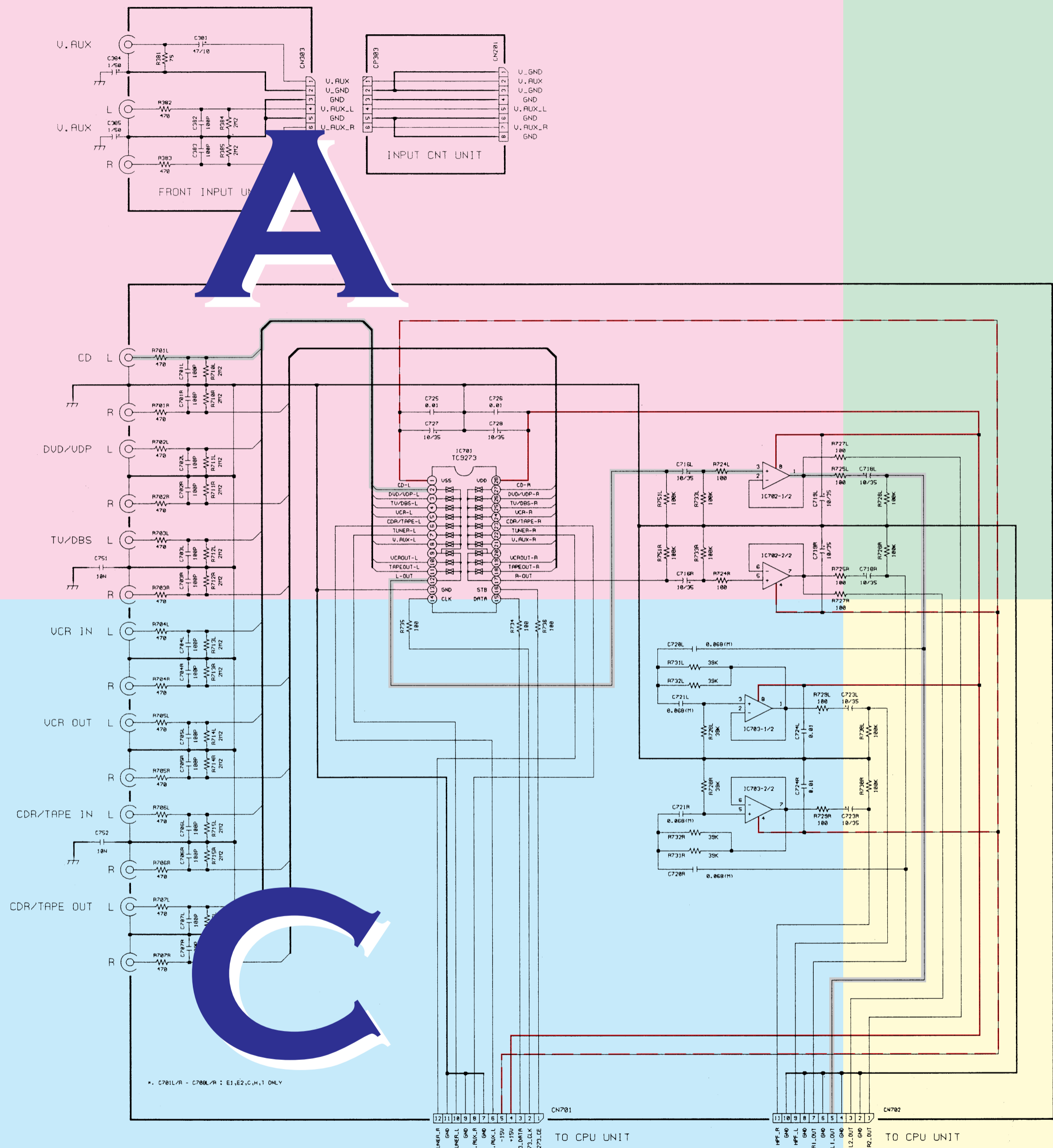

* C781L/R - C788L/R : E3,E2,G,H,I ONLY

NOTICE
 ALL RESISTANCE VALUES IN OHM. k=1,000 OHM M=1,000,000 OHM
 ALL CAPACITANCE VALUES IN MICRO FARAD. P=MICRO-MICRO FARAD
 EACH VOLTAGE AND CURRENT ARE MEASURED AT NO SIGNAL INPUT
 CONDITION.
 CIRCUIT AND PARTS ARE SUBJECT TO CHANGE WITHOUT PRIOR
 NOTICE.

WARNING:
 Parts marked with this symbol Δ have critical characteristics.
 Use ONLY replacement parts recommended by the manufacturer.

CAUTION:
 Before returning the unit to the customer, make sure you make either (1) a
 leakage current check or (2) a line to chassis resistance check. If the leakage
 current exceeds 0.5 milliamps, or if the resistance from chassis to either side
 of the power card is less than 460kohms, the unit is defective.

WARNING:
 DO NOT return the unit to the customer until the problem is located and
 corrected.

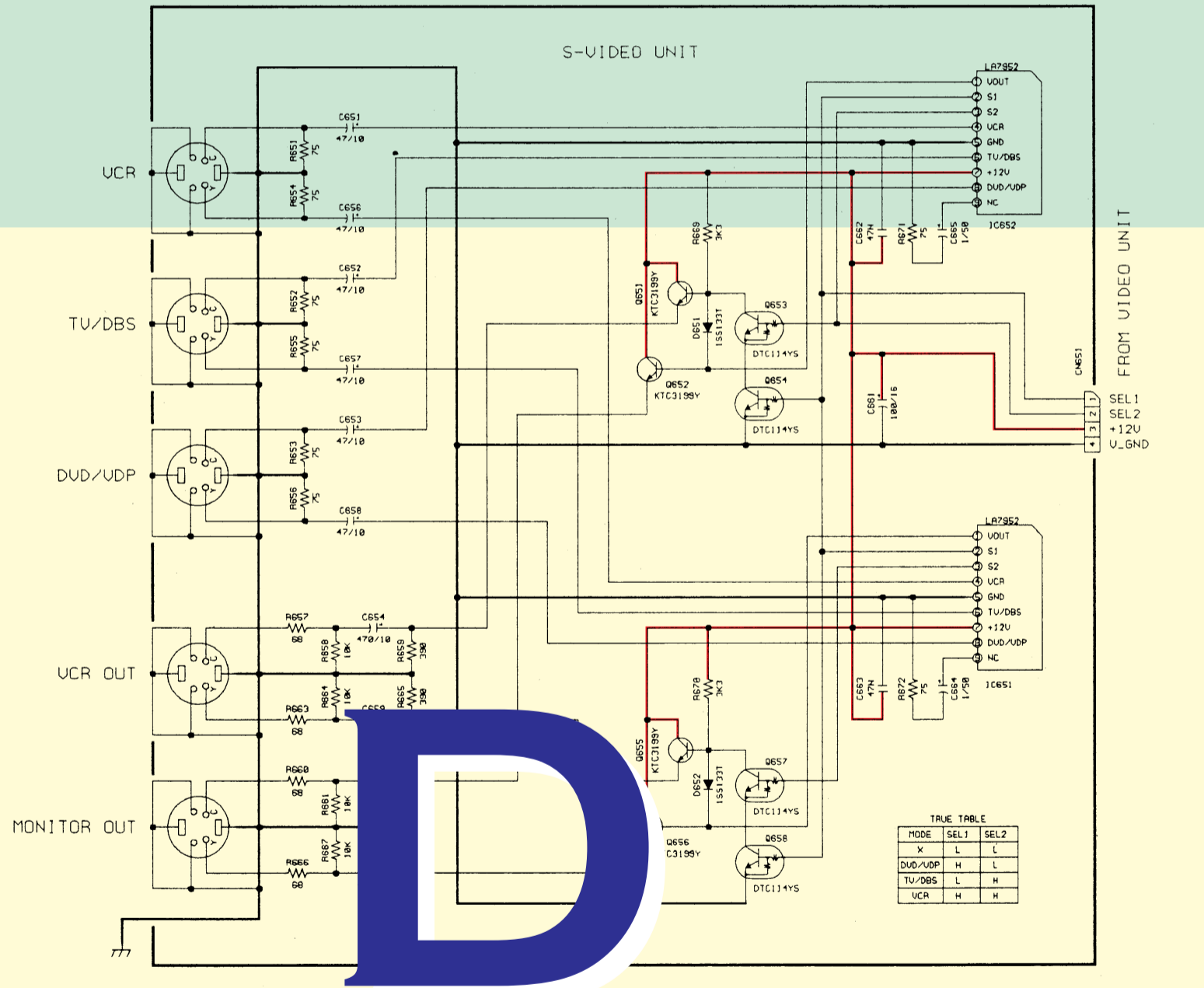
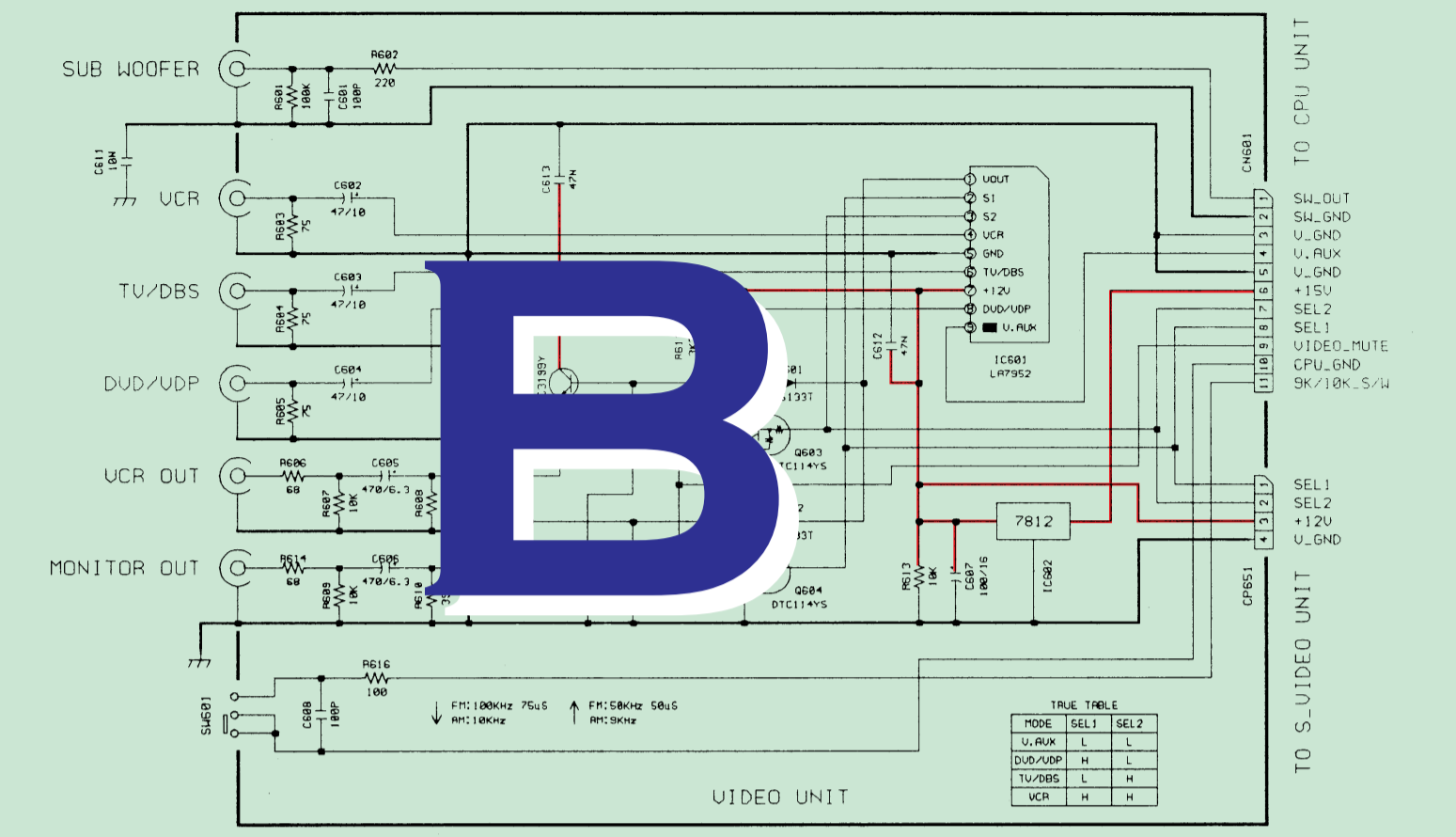

— + B LINE
 - - - - - - B LINE
 ——— SIGNAL LINE

SCHEMATIC DIAGRAMS(1/7)
 INPUT P.W.B. UNIT
 VIDEO P.W.B. UNIT
 S-VIDEO P.W.B. UNIT
 FRONT INPUT P.W.B. UNIT
 INPUT CNT P.W.B. UNIT

SCHEMATIC DIAGRAMS(1/7)

1

2

3

4

5

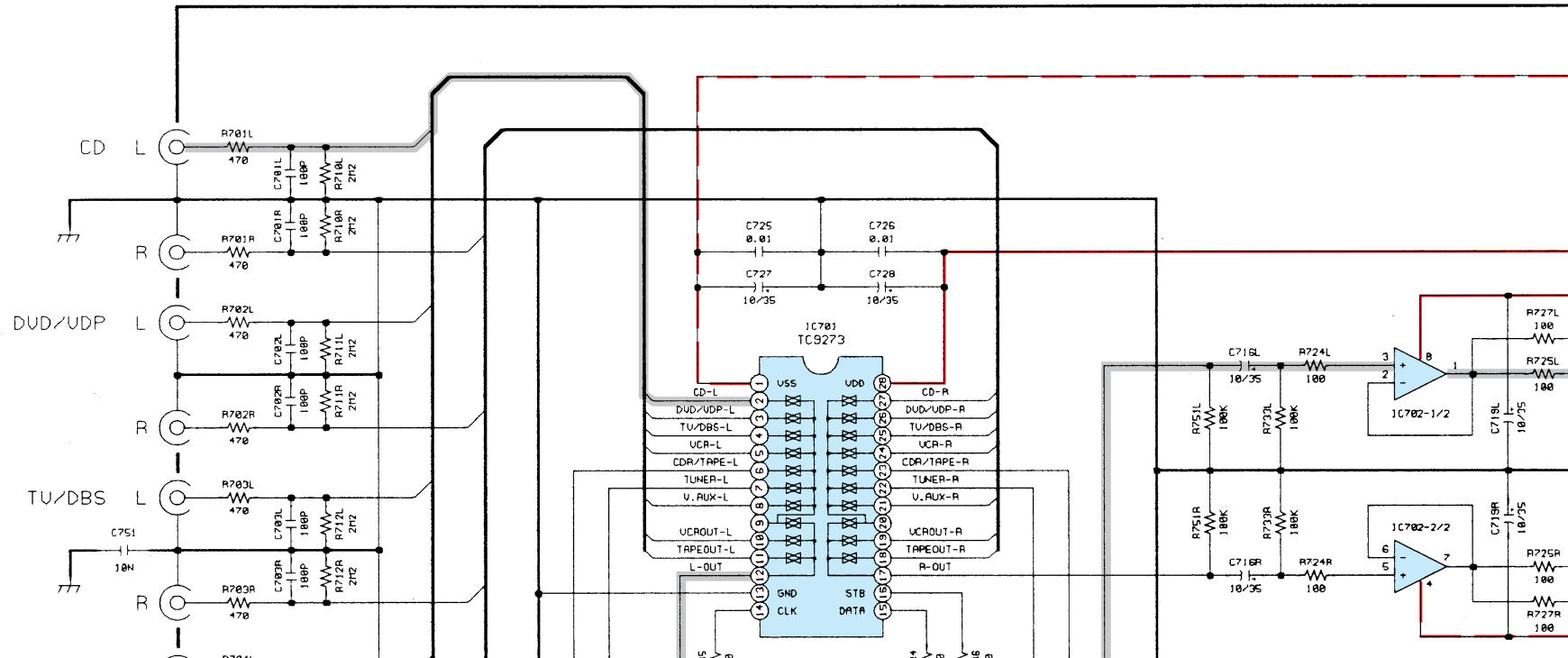
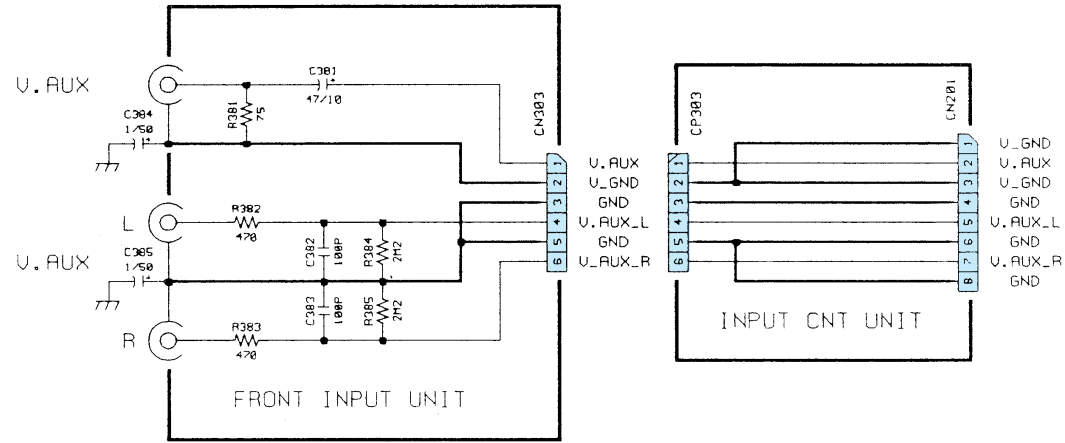

6

7

8

9

10

11

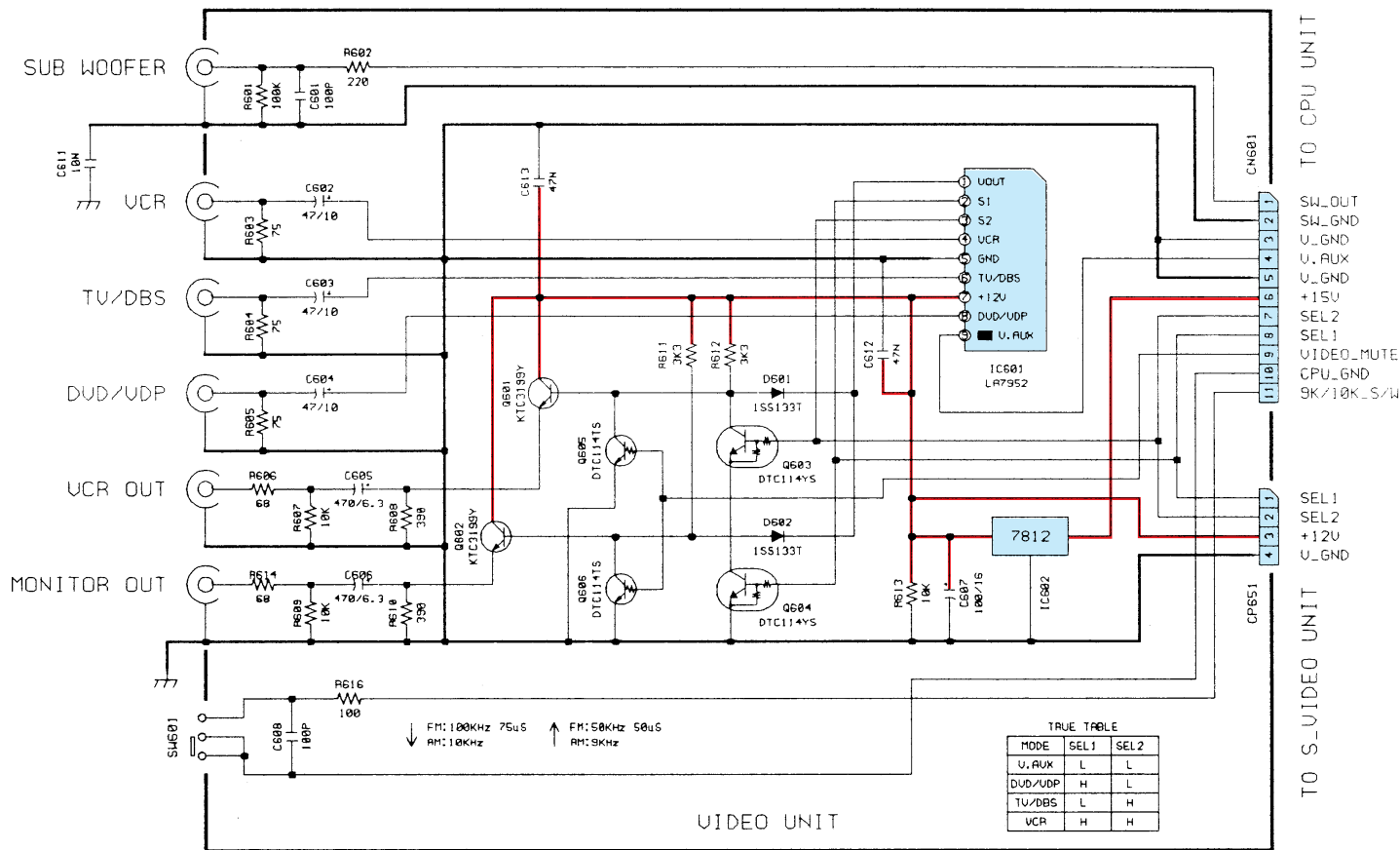

A

B

C

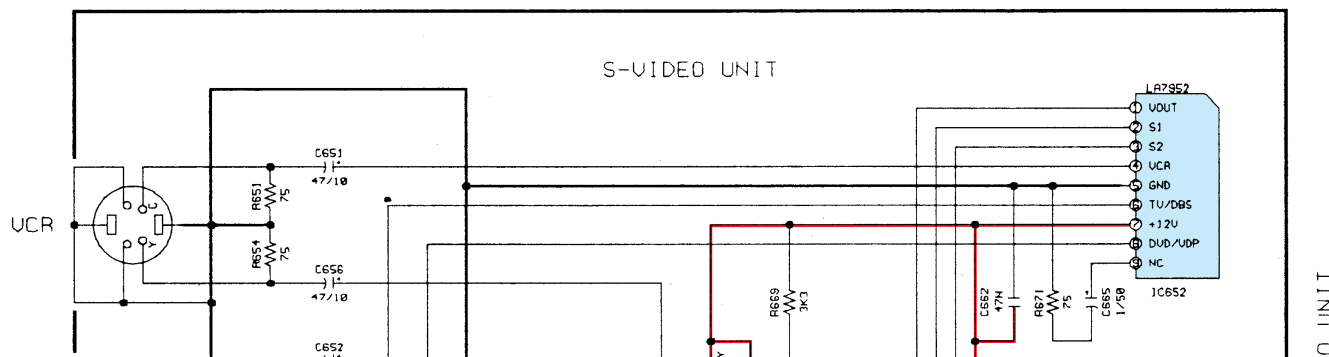
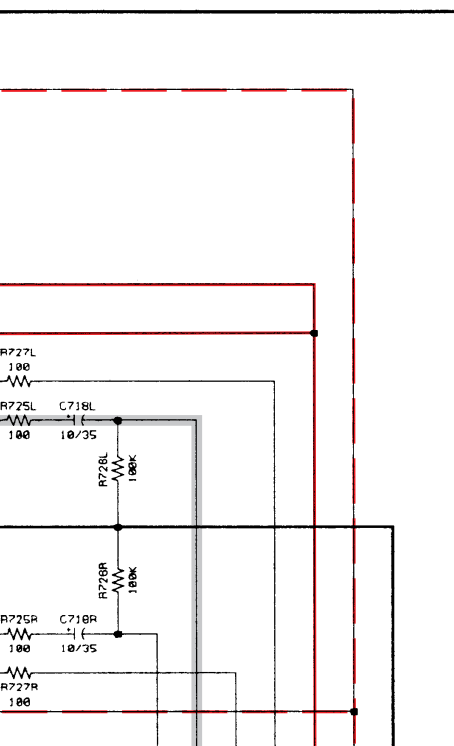

D

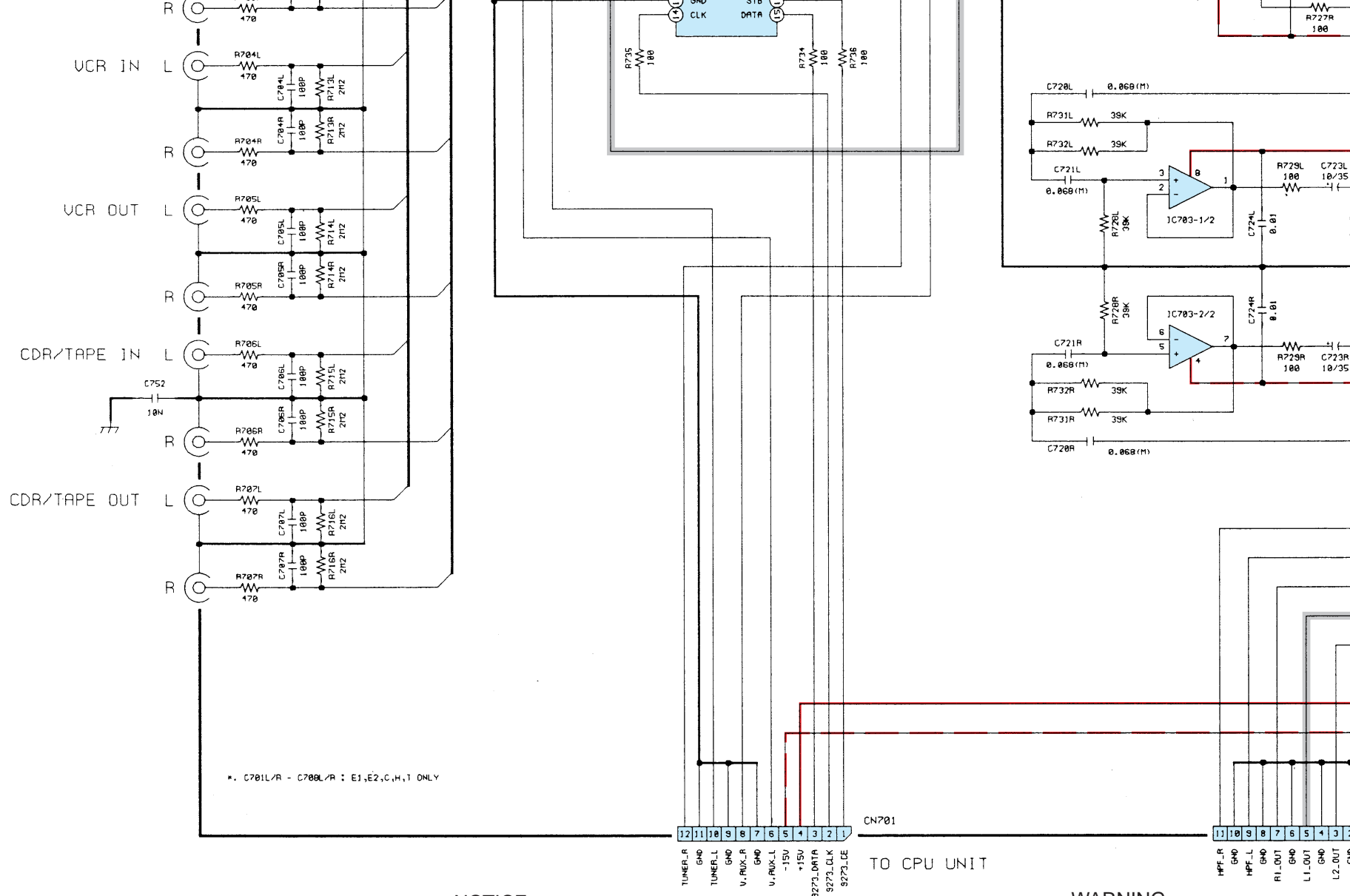

NOTICE

ALL RESISTANCE VALUES IN OHM. k=1,000 OHM M=1,000,000 OHM
 ALL CAPACITANCE VALUES IN MICRO-FARAD. P=MICRO-MICRO FARAD
 EACH VOLTAGE AND CURRENT ARE MEASURED AT MO SIGNAL INPUT
 CONDITION.
 CIRCUIT AND PARTS ARE SUBJECT TO CHANGE WITHOUT PRIOR
 NOTICE.

WARNING:

Parts marked with this symbol  have a leakage current check or (2) a line to check if the leakage current exceeds 0.5 milliamperes, or if the resistance of the power card is less than 460kohms.

CAUTION:

Before returning the unit to the customer, perform a leakage current check or (2) a line to check if the leakage current exceeds 0.5 milliamperes, or if the resistance of the power card is less than 460kohms.

WARNING:

DO NOT return the unit to the customer until the leakage current is corrected.

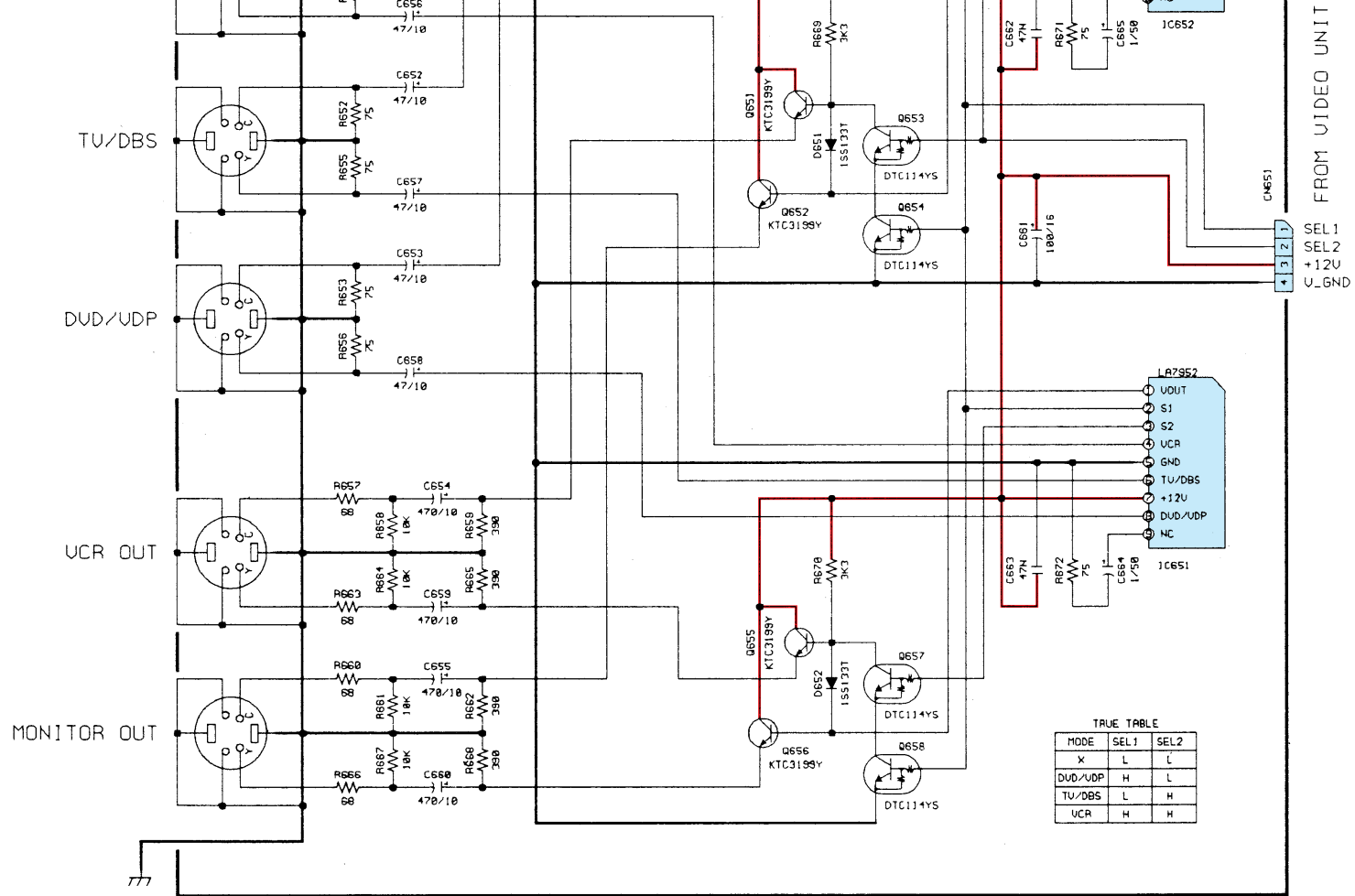
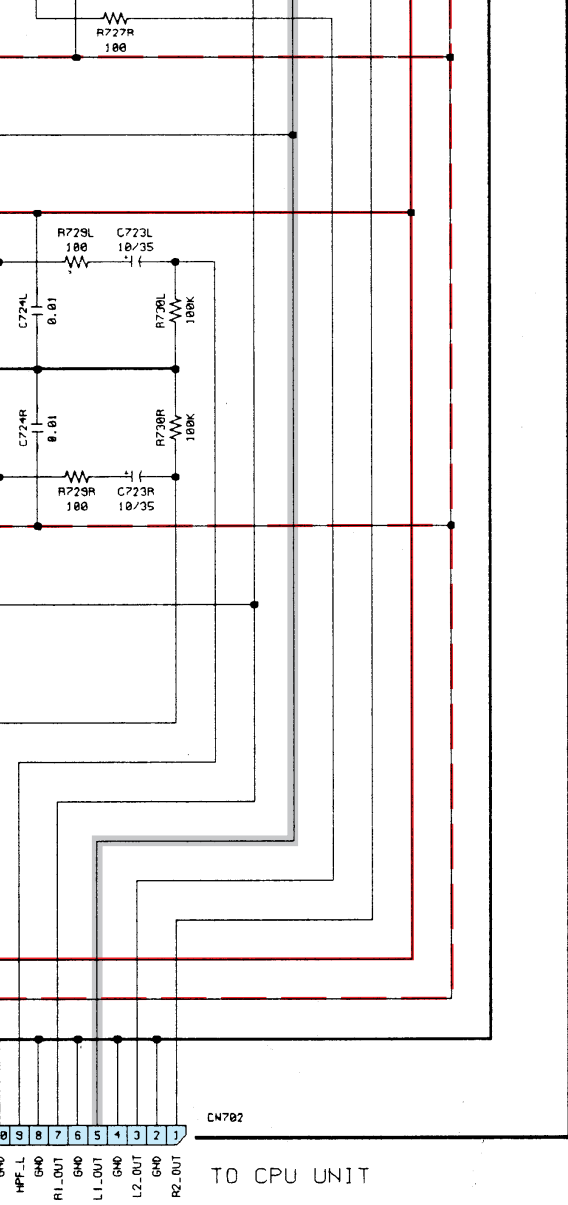

TRUE TABLE

MODE	SEL1	SEL2
X	L	L
DUD/UDP	H	L
TU/DBS	L	H
UCR	H	H

symbol have critical characteristics. parts recommended by the manufacture.

to the customer, make sure you make either (1) a or (2) a line to chassis resistance check. If the leakage liamps, or if the resistance from chassis to either side s than 460kohms, the unit is defective.

to the customer until the problem is located and



SCHEMATIC DIAGRAMS(1/7)
 INPUT P.W.B. UNIT
 VIDEO P.W.B. UNIT
 S-VIDEO P.W.B. UNIT
 FRONT INPUT P.W.B. UNIT
 INPUT CNT P.W.B. UNIT

E
F
G
H

SCHEMATIC DIAGRAMS(2/7)

1 2 3 4 5 6 7 8 9 10 11

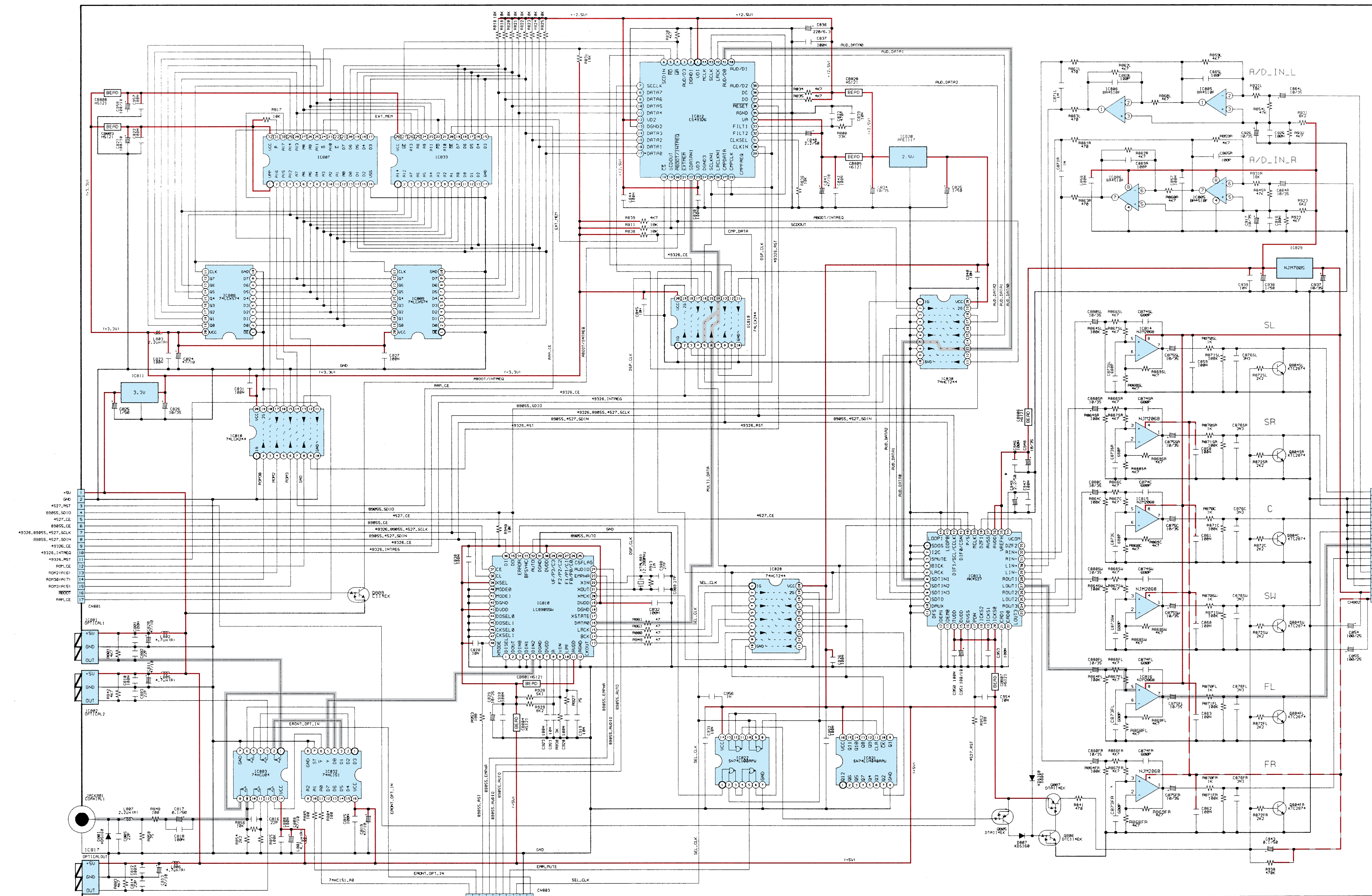

NOTICE
ALL RESISTANCE VALUES IN OHM. k=1,000 OHM M=1,000,000 OHM
ALL CAPACITANCE VALUES IN MICRO FARAD. P=MICRO-MICRO FARAD
EACH VOLTAGE AND CURRENT ARE MEASURED AT MO SIGNAL INPUT
CONDITION.
CIRCUIT AND PARTS ARE SUBJECT TO CHANGE WITHOUT PRIOR
NOTICE.

WARNING:
Parts marked with this symbol  have critical characteristics.
Use ONLY replacement parts recommended by the manufacture.
CAUTION:
Before returning the unit to the customer, make sure you make either (1) a
leakage current check or (2) a line to chassis resistance check. If the leakage
current exceeds 0.5 millamps, or if the resistance from chassis to either side
of the power card is less than 460kohms, the unit is defective.
WARNING:
DO NOT return the unit to the customer until the problem is located and
corrected.

— + B LINE
- - - - - - B LINE
— SIGNAL LINE

SCHEMATIC DIAGRAMS(2/7)
DSP P.W.B. UNIT

A
B
C
D
E
F
G
H

SCHEMATIC DIAGRAMS(2/7)

1 2 3 4 5 6 7 8 9 10 11

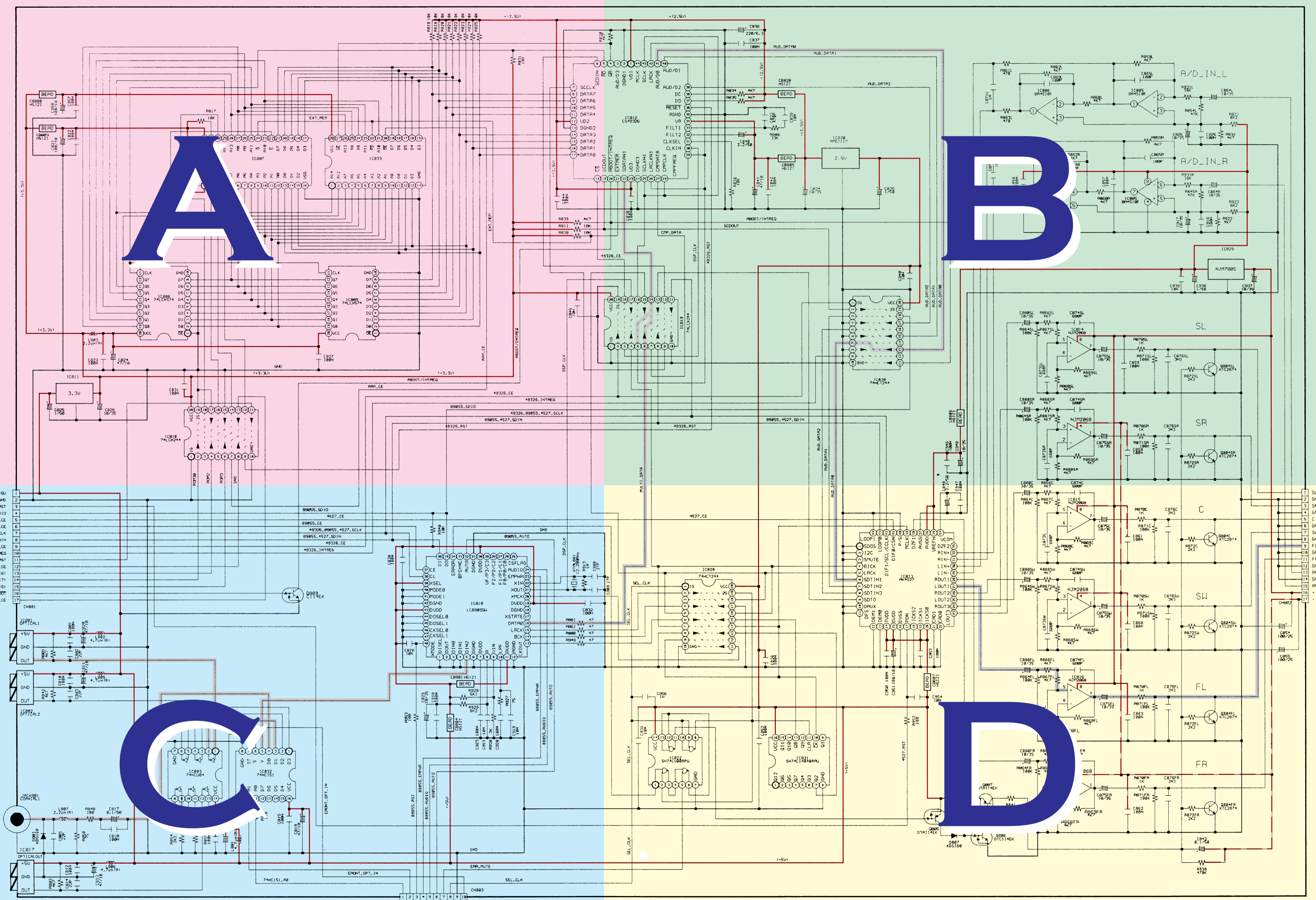

NOTICE
 ALL RESISTANCE VALUES IN OHM. K=1,000 OHM M=1,000,000 OHM
 ALL CAPACITANCE VALUES IN MICRO FARAD. P=MICRO-MICRO FARAD
 EACH VOLTAGE AND CURRENT ARE MEASURED AT MO SIGNAL INPUT
 CONDITION.
 CIRCUIT AND PARTS ARE SUBJECT TO CHANGE WITHOUT PRIOR
 NOTICE.

WARNING:
 Parts marked with this symbol Δ have critical characteristics.
 Use ONLY replacement parts recommended by the manufacturer.

CAUTION:
 Before returning the unit to the customer, make sure you make either (1) a
 leakage current check or (2) a line to chassis resistance check. If the leakage
 current exceeds 0.5 milliamps, or if the resistance from chassis to either side
 of the power card is less than 460kohms, the unit is defective.

WARNING:
 DO NOT return the unit to the customer until the problem is located and
 corrected.

— + B LINE
 - - - - - B LINE
 ——— SIGNAL LINE

SCHEMATIC DIAGRAMS(2/7)
 DSP P.W.B. UNIT

SCHEMATIC DIAGRAMS(2/7)

1

2

3

4

5

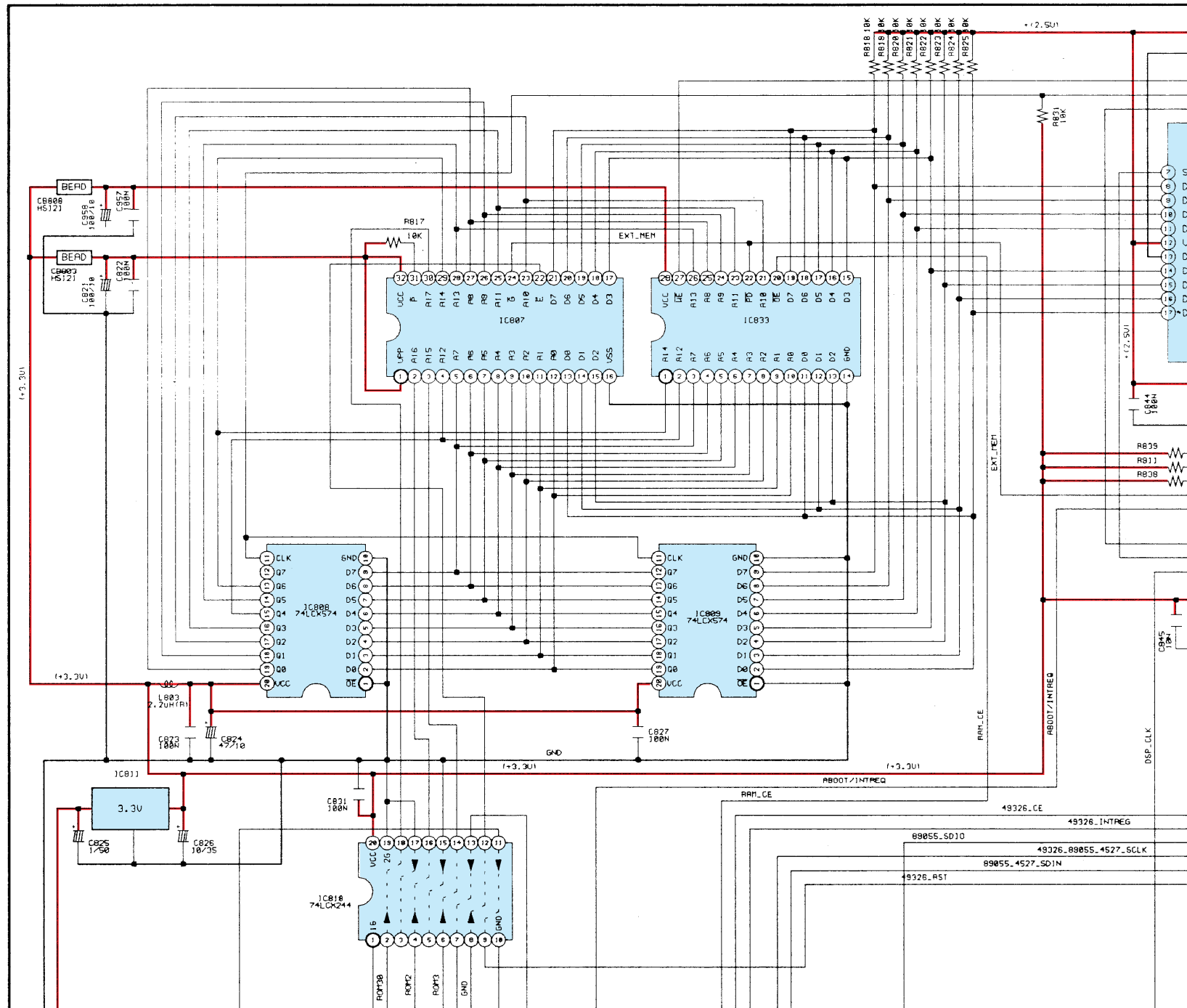

6

7

8

9

10

11

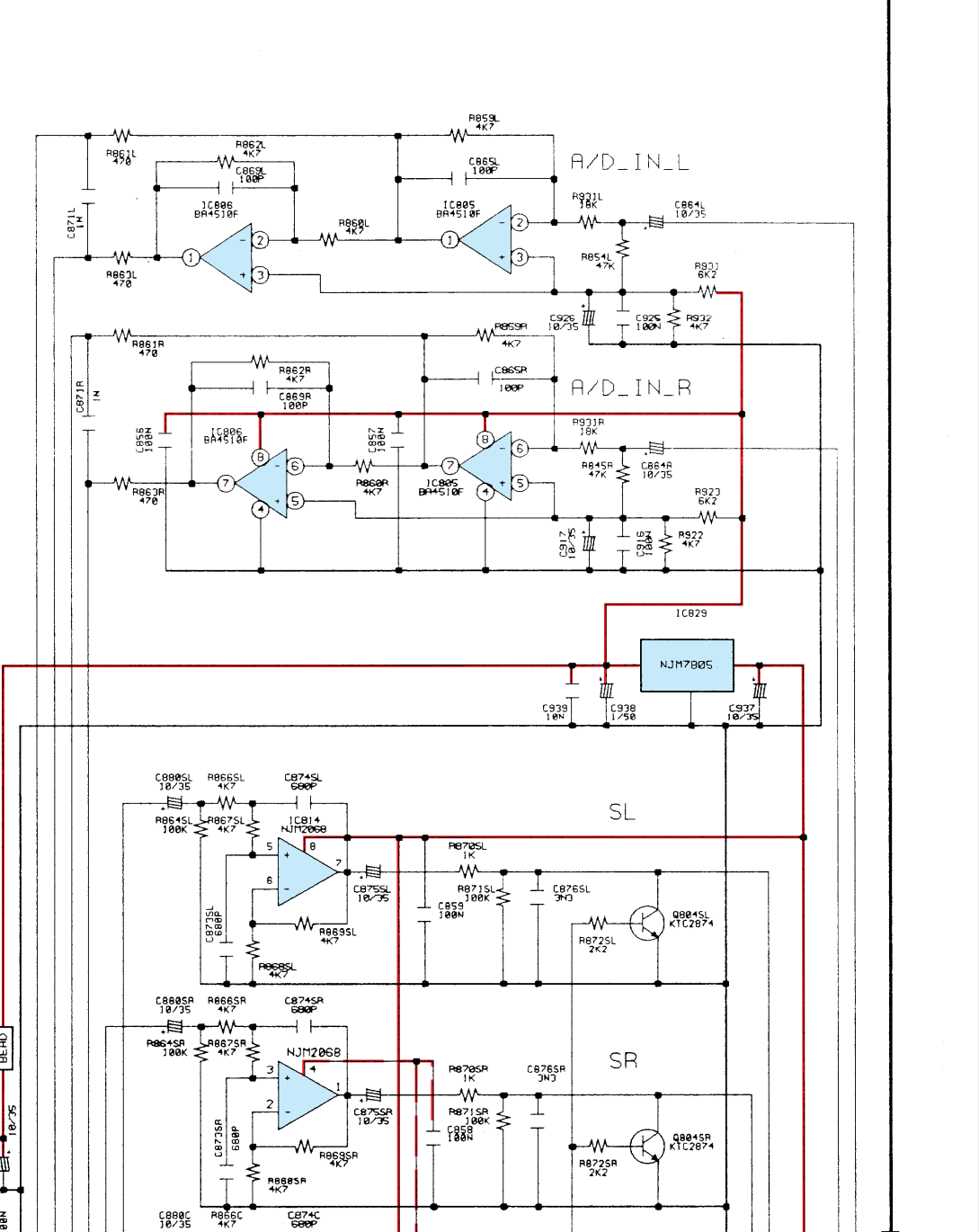
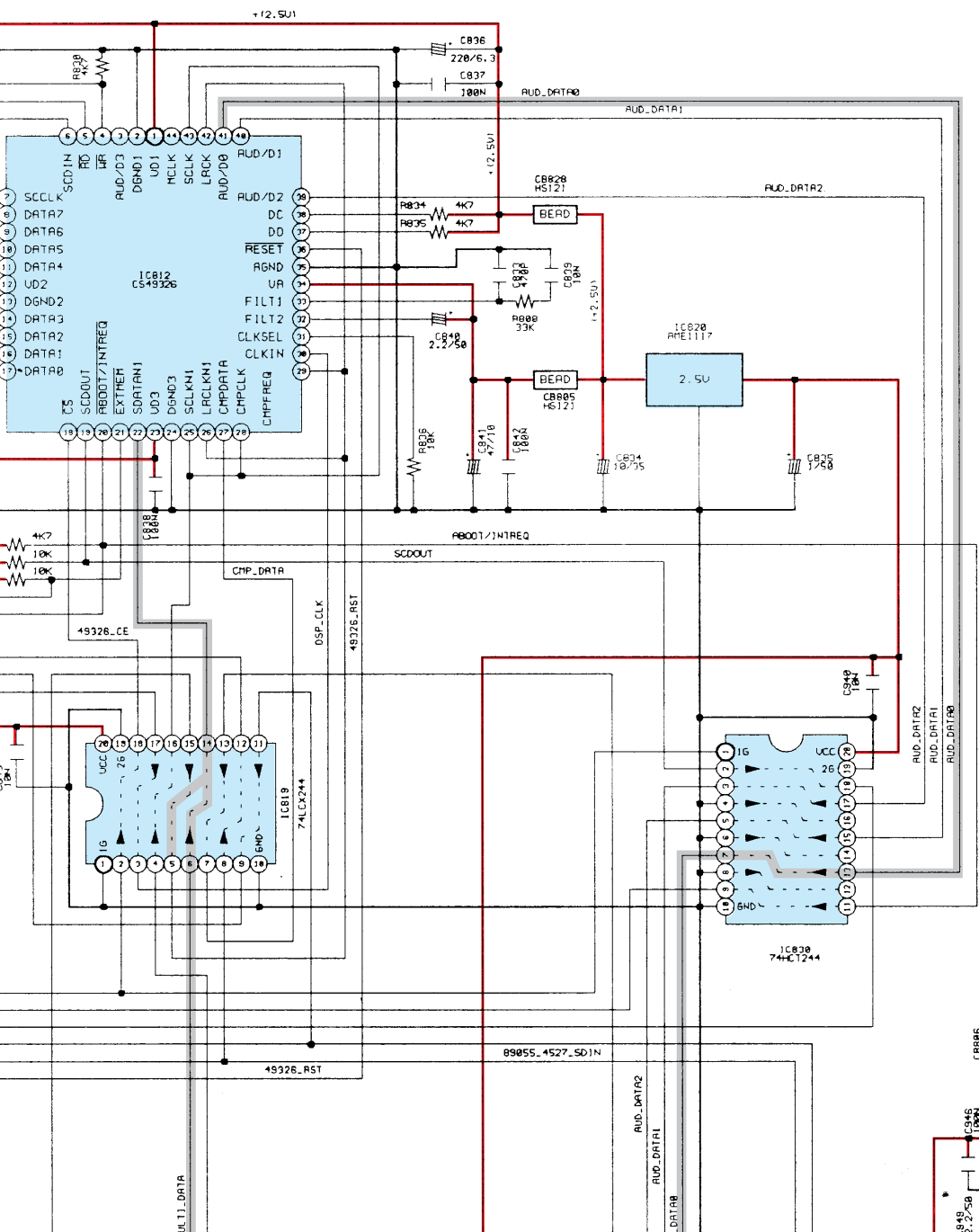

A

B

C

D

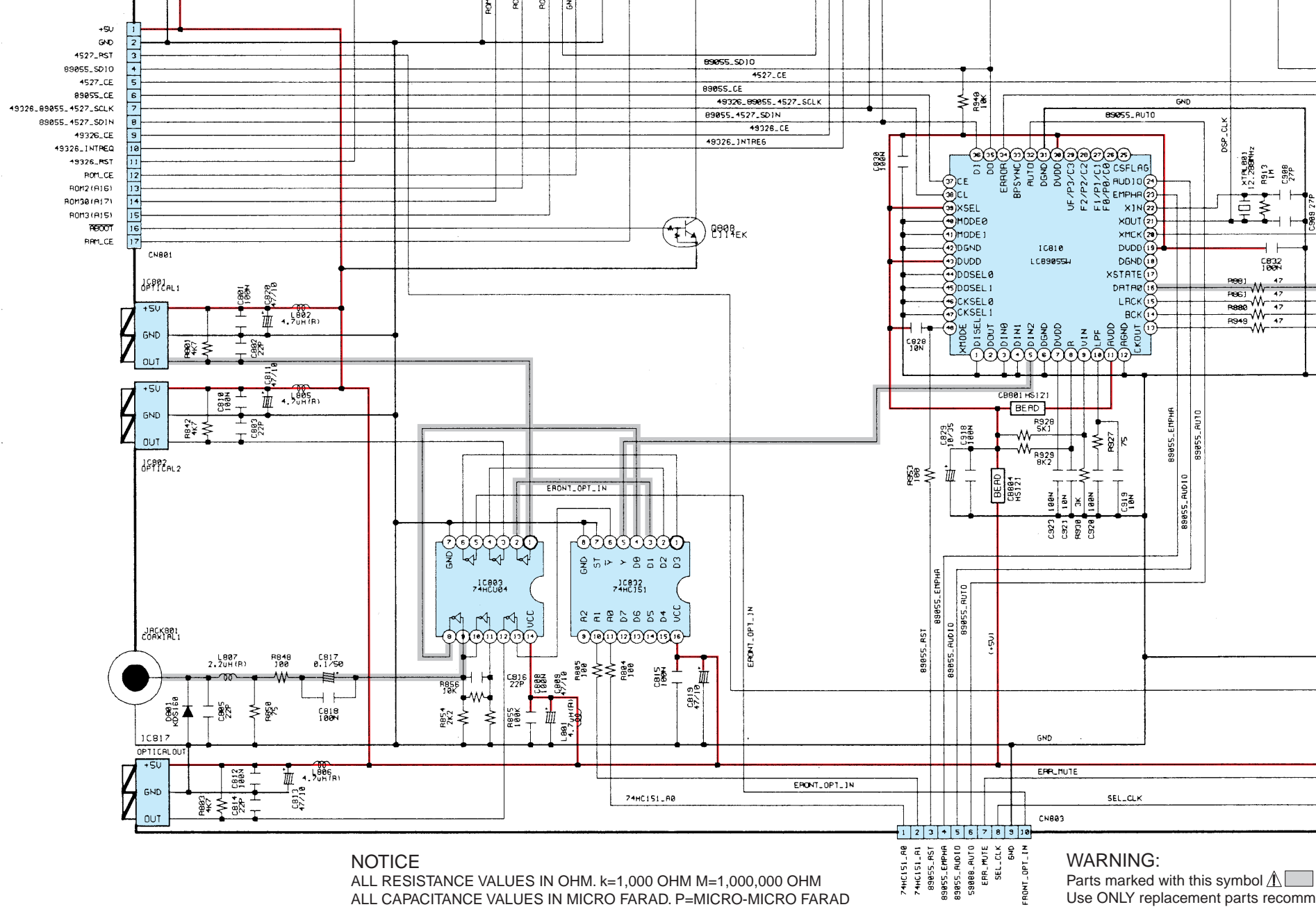

NOTICE

ALL RESISTANCE VALUES IN OHM. k=1,000 OHM M=1,000,000 OHM
 ALL CAPACITANCE VALUES IN MICRO FARAD. P=MICRO-MICRO FARAD
 EACH VOLTAGE AND CURRENT ARE MEASURED AT MO SIGNAL INPUT
 CONDITION.
 CIRCUIT AND PARTS ARE SUBJECT TO CHANGE WITHOUT PRIOR
 NOTICE.

WARNING:

Parts marked with this symbol  Use ONLY replacement parts recomm

CAUTION:

Before returning the unit to the custom
 leakage current check or (2) a line to c
 current exceeds 0.5 milliamps, or if the
 of the power card is less than 460khr

WARNING:

DO NOT return the unit to the custom
 corrected.

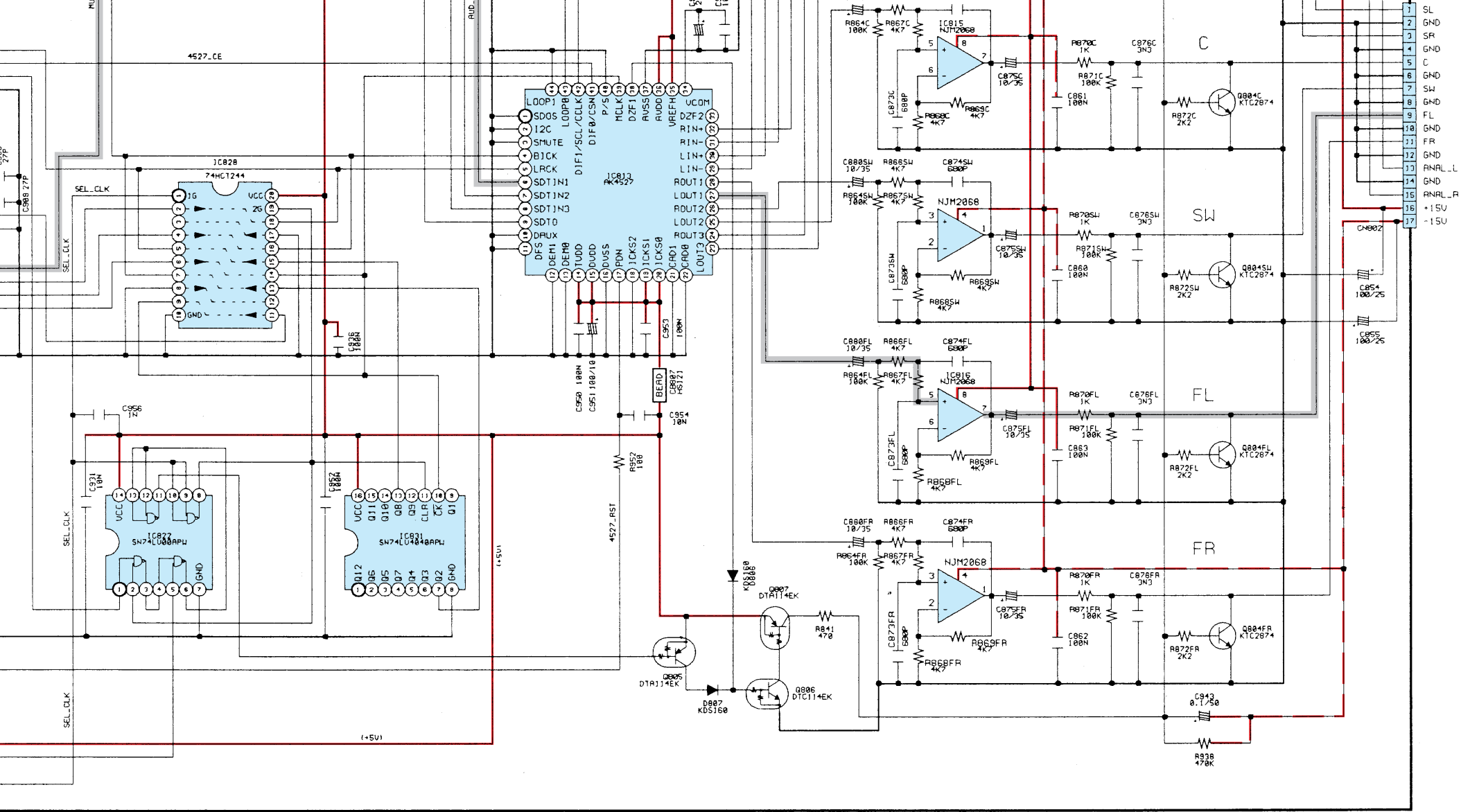

have critical characteristics.
 recommended by the manufacture.

customer, make sure you make either (1) a
 to chassis resistance check. If the leakage
 if the resistance from chassis to either side
 kohms, the unit is defective.

customer until the problem is located and

- + B LINE
- - - - B LINE
- SIGNAL LINE

SCHEMATIC DIAGRAMS(2/7) DSP P.W.B. UNIT

E
 F
 G
 H

SCHEMATIC DIAGRAMS(3/7)

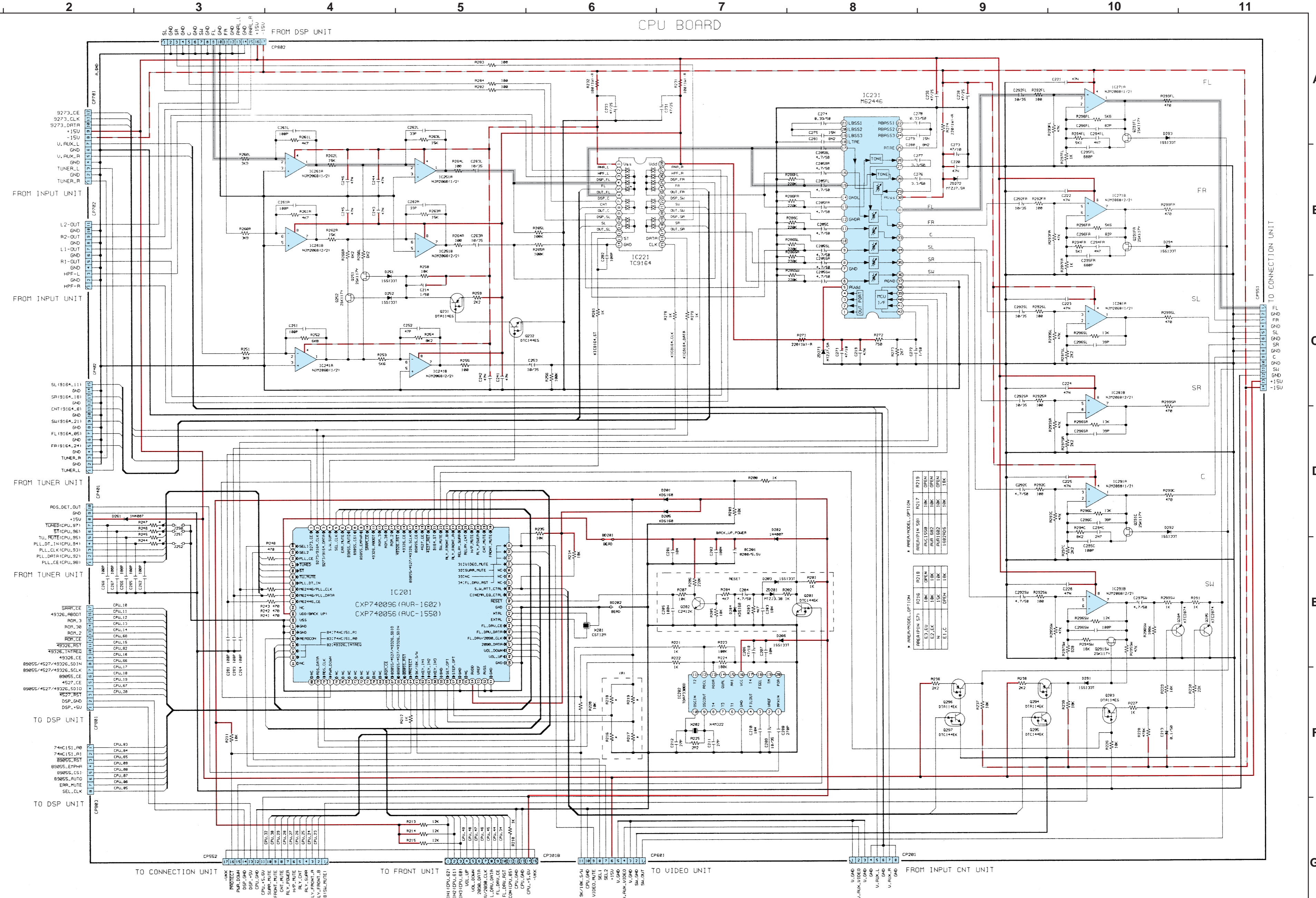

WARNING:
Parts marked with this symbol have critical characteristics. Use ONLY replacement parts recommended by the manufacturer.

CAUTION:
Before returning the unit to the customer, make sure you make either (1) a leakage current check or (2) a line to chassis resistance check. If the leakage current exceeds 0.5 milliamps, or if the resistance from chassis to either side of the power card is less than 460kohms, the unit is defective.

WARNING:
DO NOT return the unit to the customer until the problem is located and corrected.

NOTICE
ALL RESISTANCE VALUES IN OHM. k=1,000 OHM M=1,000,000 OHM
ALL CAPACITANCE VALUES IN MICRO FARAD. P=MICRO-MICRO FARAD
EACH VOLTAGE AND CURRENT ARE MEASURED AT MO SIGNAL INPUT CONDITION.
CIRCUIT AND PARTS ARE SUBJECT TO CHANGE WITHOUT PRIOR NOTICE.

— + B LINE
— - B LINE
— SIGNAL LINE

SCHEMATIC DIAGRAMS(3/7)
CPU P.W.B. UNIT

SCHEMATIC DIAGRAMS(3/7)

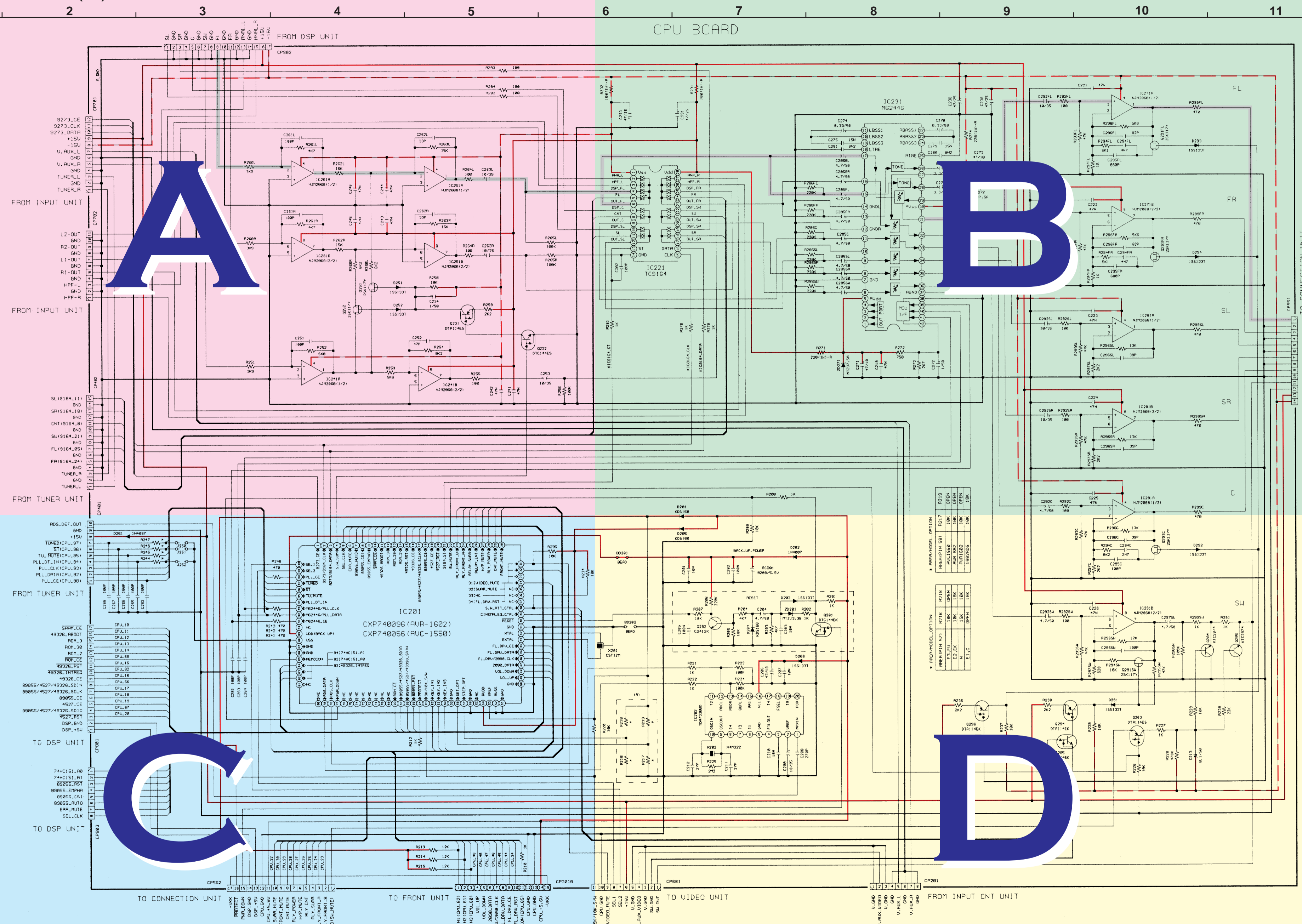

A

B

C

D

WARNING:
Parts marked with this symbol have critical characteristics.
Use ONLY replacement parts recommended by the manufacture.

CAUTION:
Before returning the unit to the customer, make sure you make either (1) a leakage current check or (2) a line to chassis resistance check. If the leakage current exceeds 0.5 milliamperes, or if the resistance from chassis to either side of the power card is less than 460kohms, the unit is defective.

WARNING:
DO NOT return the unit to the customer until the problem is located and corrected.

NOTICE
ALL RESISTANCE VALUES IN OHM. k=1,000 OHM M=1,000,000 OHM
ALL CAPACITANCE VALUES IN MICRO FARAD. p=MICRO-MICRO FARAD
EACH VOLTAGE AND CURRENT ARE MEASURED AT MO SIGNAL INPUT
CONDITION.
CIRCUIT AND PARTS ARE SUBJECT TO CHANGE WITHOUT PRIOR NOTICE.

— + B LINE
— - B LINE
— SIGNAL LINE

SCHEMATIC DIAGRAMS(3/7)
CPU P.W.B. UNIT

SCHEMATIC DIAGRAMS(3/7)

1

2

3

4

5

6

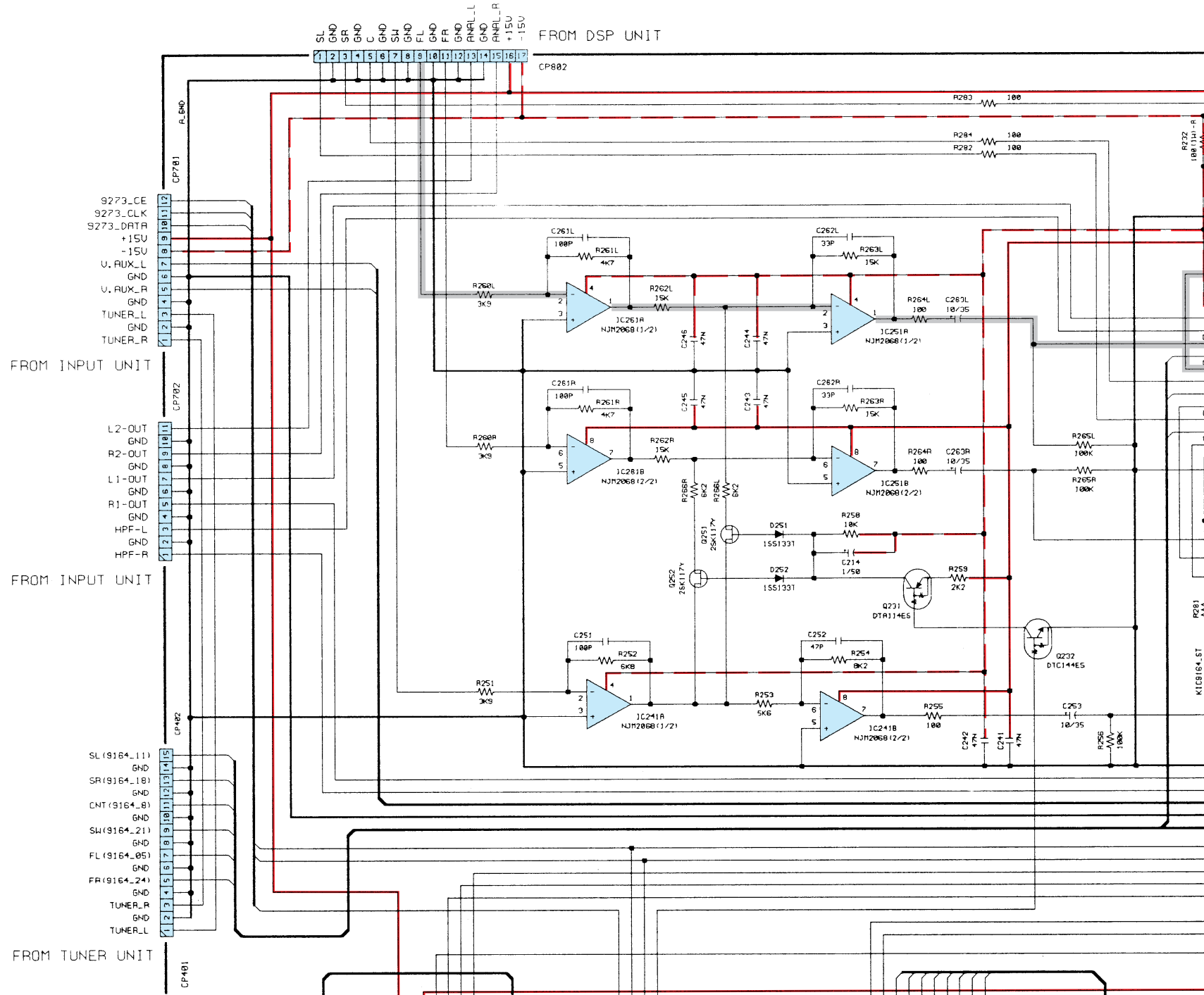

6

7

8

9

10

11

CPU BOARD

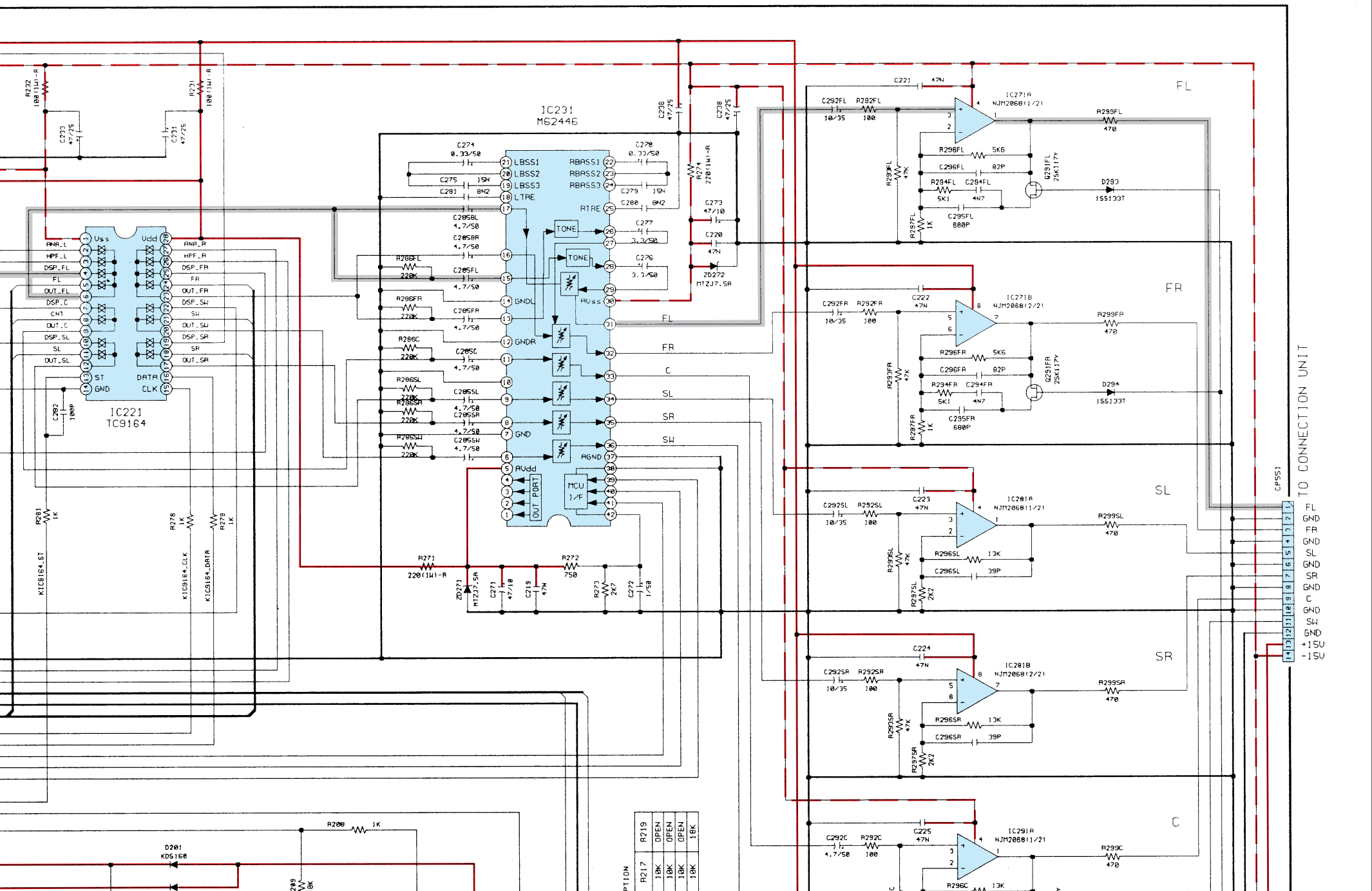

A

B

C

D

OPTION	R217	R219
	10K	OPEN
	10K	OPEN
	10K	OPEN
	10K	18K

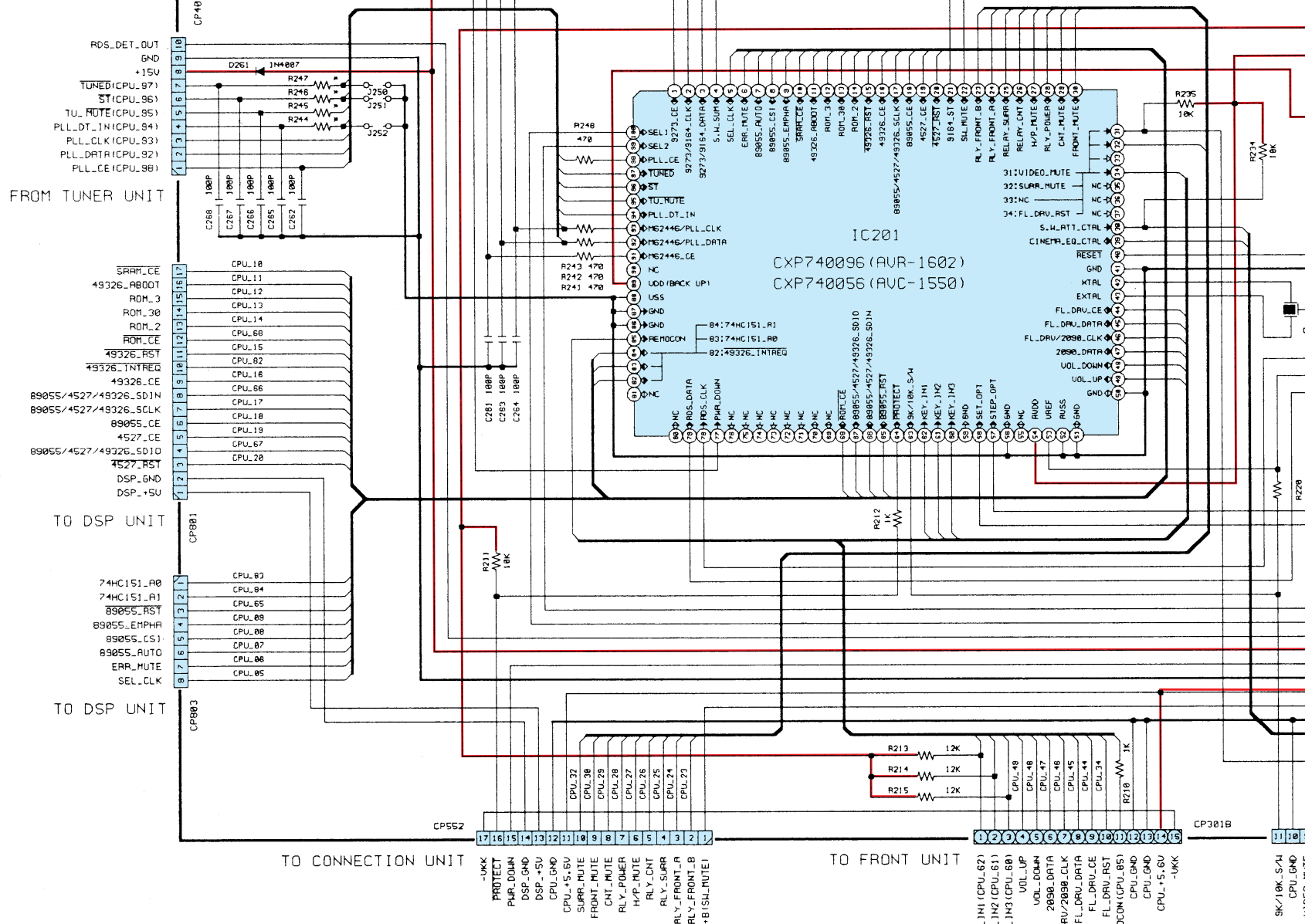

WARNING:

Parts marked with this symbol have critical characteristics. Use ONLY replacement parts recommended by the manufacturer.

CAUTION:

Before returning the unit to the customer, make sure you make either (1) a leakage current check or (2) a line to chassis resistance check. If the leakage current exceeds 0.5 milliamps, or if the resistance from chassis to either side of the power card is less than 460kohms, the unit is defective.

WARNING:

DO NOT return the unit to the customer until the problem is located and corrected.

NOTICE

ALL RESISTANCE VALUES IN ALL CAPACITANCE VALUES IN EACH VOLTAGE AND CURRENT CONDITION. CIRCUIT AND PARTS ARE SUBJECT TO CHANGE WITHOUT NOTICE.

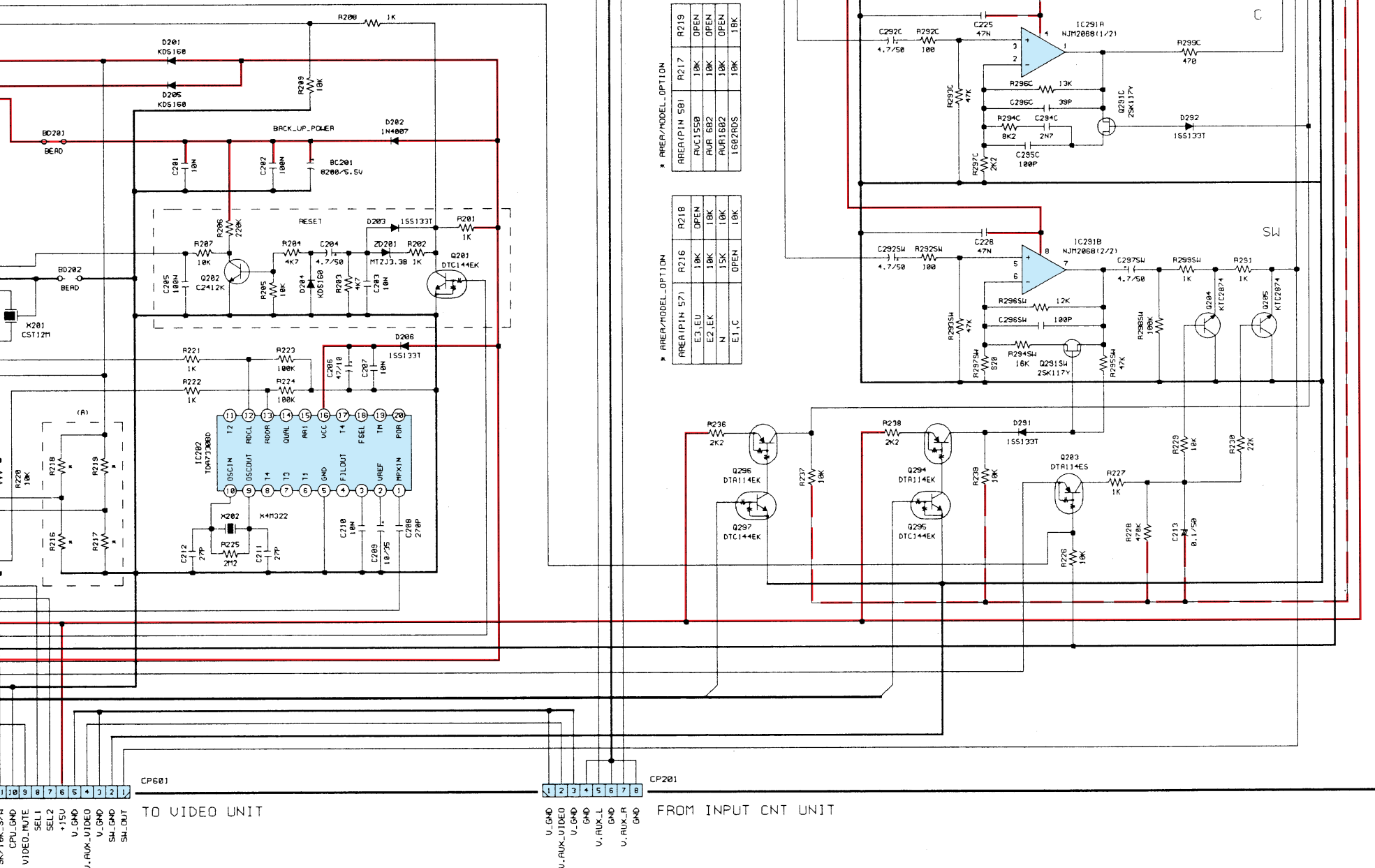

* AREA/MODEL_OPTION

AREA(IPIN 5B)	R217	19K	OPEN	19K
RVL155B	19K	OPEN	19K	OPEN
RUR16B2	19K	OPEN	19K	OPEN
RUR16B2	19K	OPEN	19K	OPEN
I6B2RDS	19K	OPEN	19K	19K

* AREA/MODEL_OPTION

AREA(IPIN 57)	R216	19K	OPEN	19K
E3_EU	19K	OPEN	19K	OPEN
E2_EK	19K	OPEN	19K	OPEN
N	15K	OPEN	19K	OPEN
E1_C	19K	OPEN	19K	OPEN

— + B LINE
- - - - B LINE
— SIGNAL LINE

SCHEMATIC DIAGRAMS(3/7)
CPU P.W.B. UNIT

Ω IN OHM. k=1,000 OHM M=1,000,000 OHM
 S IN MICRO FARAD. P=MICRO-MICRO FARAD
 RENT ARE MEASURED AT MO SIGNAL INPUT

SUBJECT TO CHANGE WITHOUT PRIOR

D
E
F
G
H

SCHEMATIC DIAGRAMS(4/7)

1 2 3 4 5 6 7 8 9 10 11

SCHEMATIC DIAGRAM

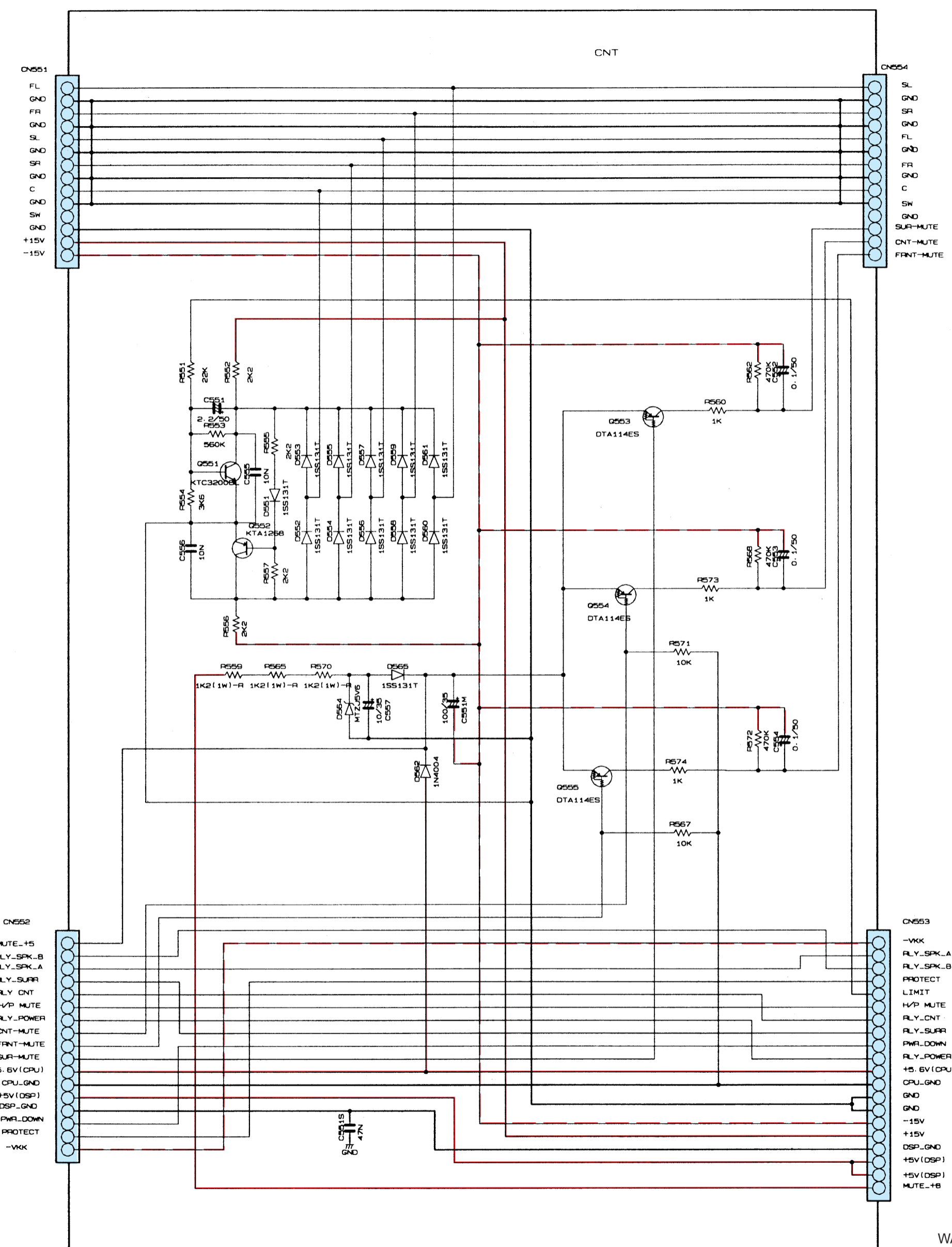

CN552
 MUTE_+15
 RLY_SPK_B
 RLY_SPK_A
 RLY_SURR
 RLY_CNT
 H/P MUTE
 RLY_POWER
 CNT-MUTE
 FRNT-MUTE
 SUR-MUTE
 +5_V(CPU)
 CPU_GND
 +5V(DSP)
 DSP_GND
 PWR_DOWN
 PROTECT
 -VKK

CN553
 -VKK
 RLY_SPK_A
 RLY_SPK_B
 PROTECT
 LIMIT
 H/P MUTE
 RLY_CNT
 RLY_SURR
 PWR_DOWN
 RLY_POWER
 +5_V(CPU)
 CPU_GND
 GND
 GND
 -15V
 +15V
 DSP_GND
 +5V(DSP)
 +5V(DSP)
 MUTE_+16

NOTICE
 ALL RESISTANCE VALUES IN OHM. k=1,000 OHM M=1,000,000 OHM
 ALL CAPACITANCE VALUES IN MICRO FARAD. P=MICRO-MICRO FARAD
 EACH VOLTAGE AND CURRENT ARE MEASURED AT MO SIGNAL INPUT
 CONDITION.
 CIRCUIT AND PARTS ARE SUBJECT TO CHANGE WITHOUT PRIOR
 NOTICE.

WARNING:
 Parts marked with this symbol Δ have critical characteristics.
 Use ONLY replacement parts recommended by the manufacture.

CAUTION:
 Before returning the unit to the customer, make sure you make either (1) a
 leakage current check or (2) a line to chassis resistance check. If the leakage
 current exceeds 0.5 milliamps, or if the resistance from chassis to either side
 of the power card is less than 460kohms, the unit is defective.

WARNING:
 DO NOT return the unit to the customer until the problem is located and
 corrected.

— + B LINE
 - - - - - B LINE
 ——— SIGNAL LINE

SCHEMATIC DIAGRAMS(4/7)
 CNT P.W.B. UNIT
 PRE-AMP P.W.B. UNIT

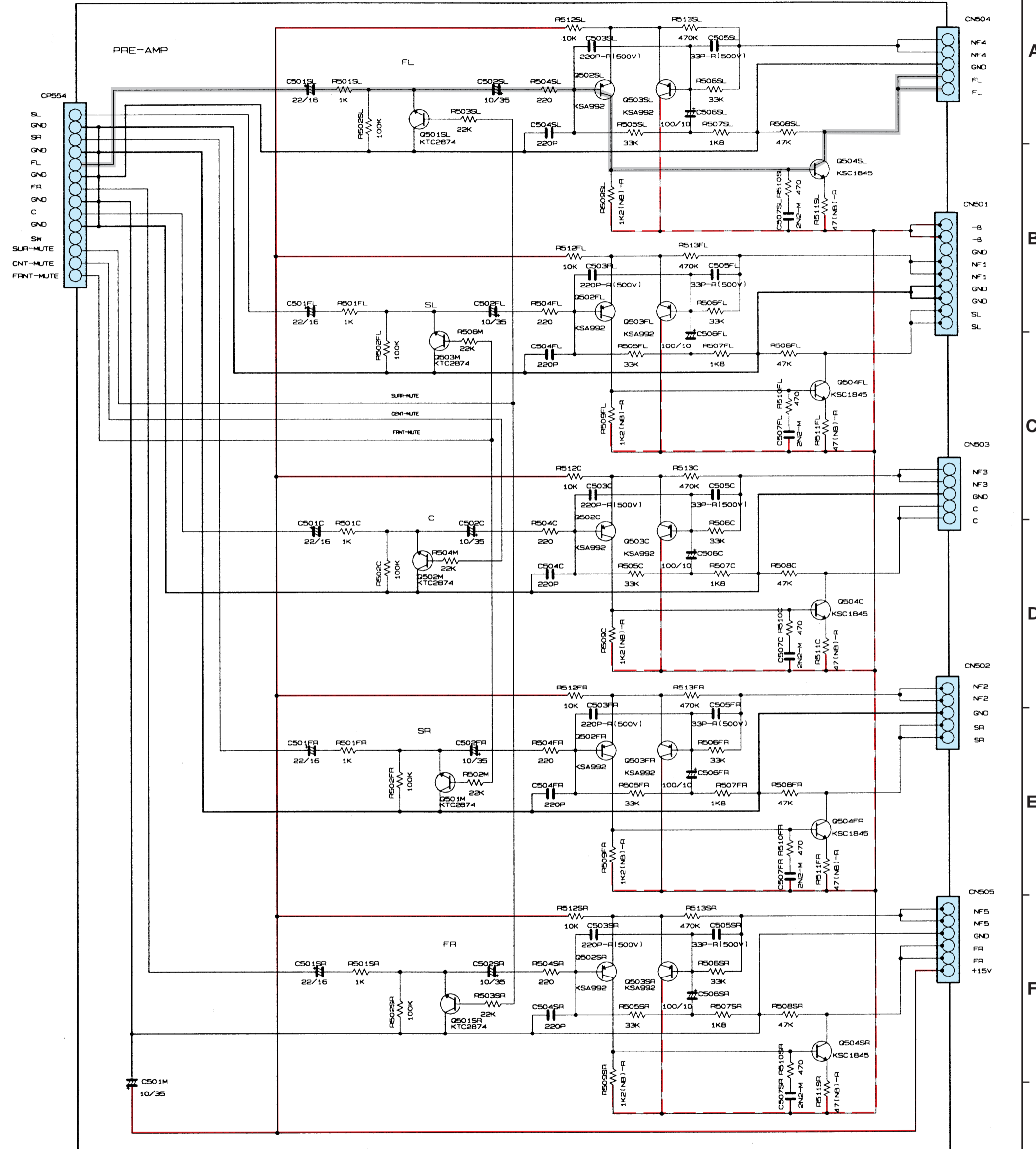

CN554
 SL
 GND
 SR
 GND
 FL
 GND
 FR
 GND
 C
 GND
 SW
 SUR-MUTE
 CNT-MUTE
 FRNT-MUTE

CN504
 NF4
 GND
 FL
 FL
 CN501
 -B
 GND
 NF1
 GND
 SL
 SL
 CN503
 NF3
 GND
 C
 C
 CN502
 NF2
 GND
 SR
 SR
 CN505
 NF5
 NF5
 GND
 FR
 FR
 +15V

SCHEMATIC DIAGRAMS(4/7)

1 2 3 4 5 6 7 8 9 10 11

SCHEMATIC DIAGRAM

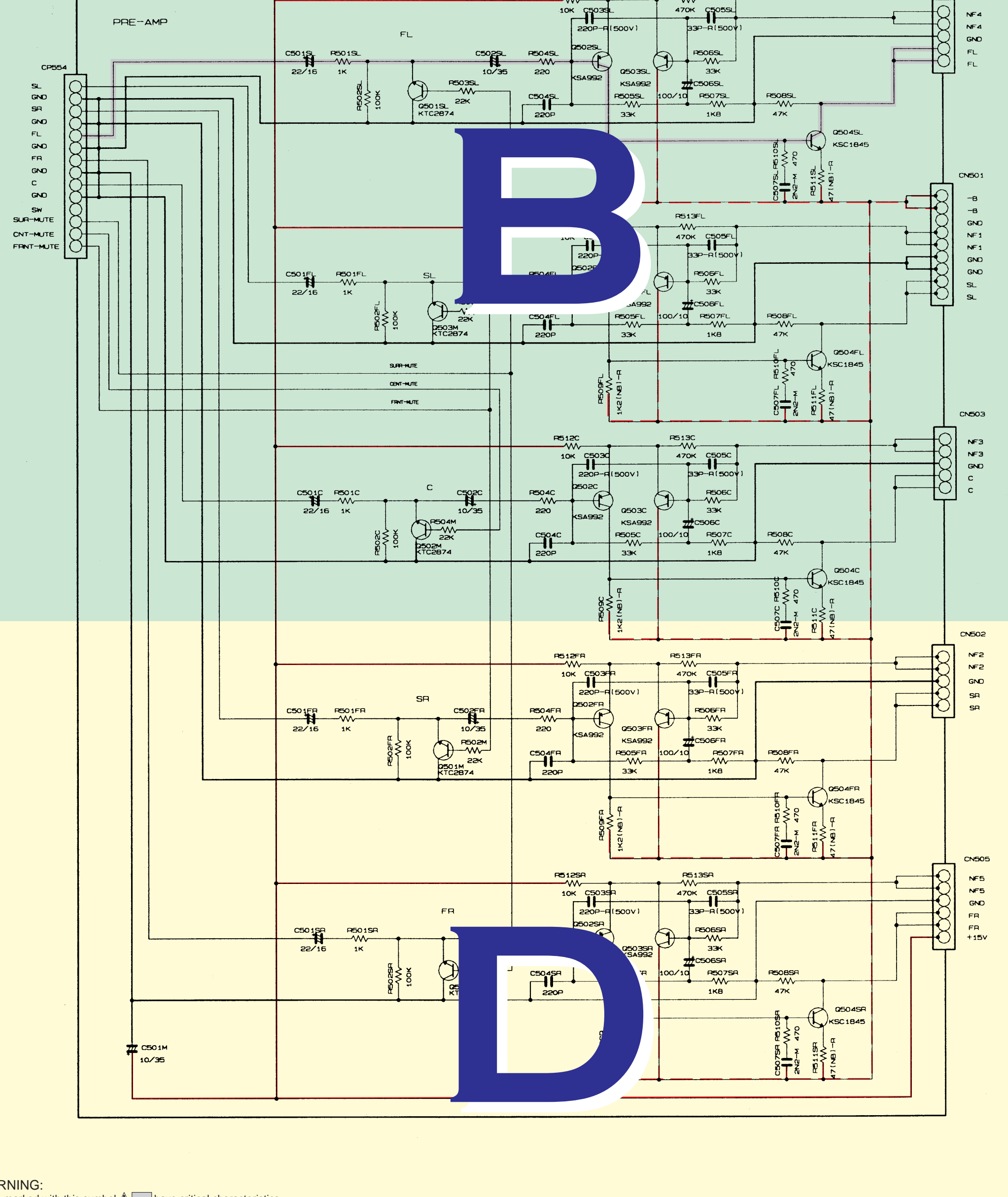
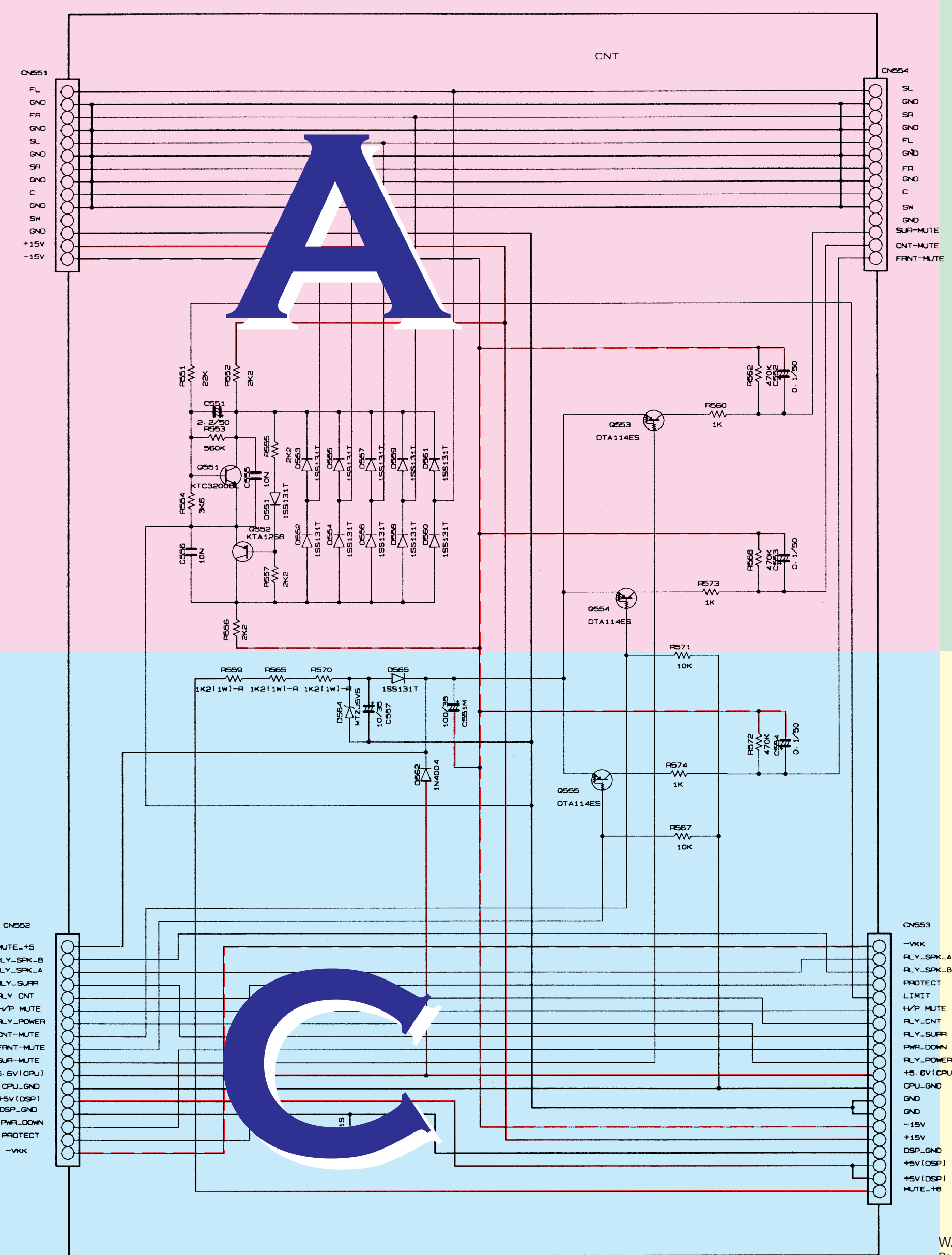

NOTICE
 ALL RESISTANCE VALUES IN OHM, k=1,000 OHM M=1,000,000 OHM
 ALL CAPACITANCE VALUES IN MICRO FARAD, P=MICRO-MICRO FARAD
 EACH VOLTAGE AND CURRENT ARE MEASURED AT MO SIGNAL INPUT
 CONDITION.
 CIRCUIT AND PARTS ARE SUBJECT TO CHANGE WITHOUT PRIOR
 NOTICE.

WARNING:
 Parts marked with this symbol Δ have critical characteristics.
 Use ONLY replacement parts recommended by the manufacturer.

CAUTION:
 Before returning the unit to the customer, make sure you make either (1) a
 leakage current check or (2) a line to chassis resistance check. If the leakage
 current exceeds 0.5 milliamps, or if the resistance from chassis to either side
 of the power card is less than 460kohms, the unit is defective.

WARNING:
 DO NOT return the unit to the customer until the problem is located and
 corrected.

— + B LINE
 - - - - - B LINE
 ——— SIGNAL LINE

SCHEMATIC DIAGRAMS(4/7)
 CNT P.W.B. UNIT
 PRE-AMP P.W.B. UNIT

SCHEMATIC DIAGRAMS(4/7)

1

2

3

4

5

6

SCHEMATIC

DIAGRAM

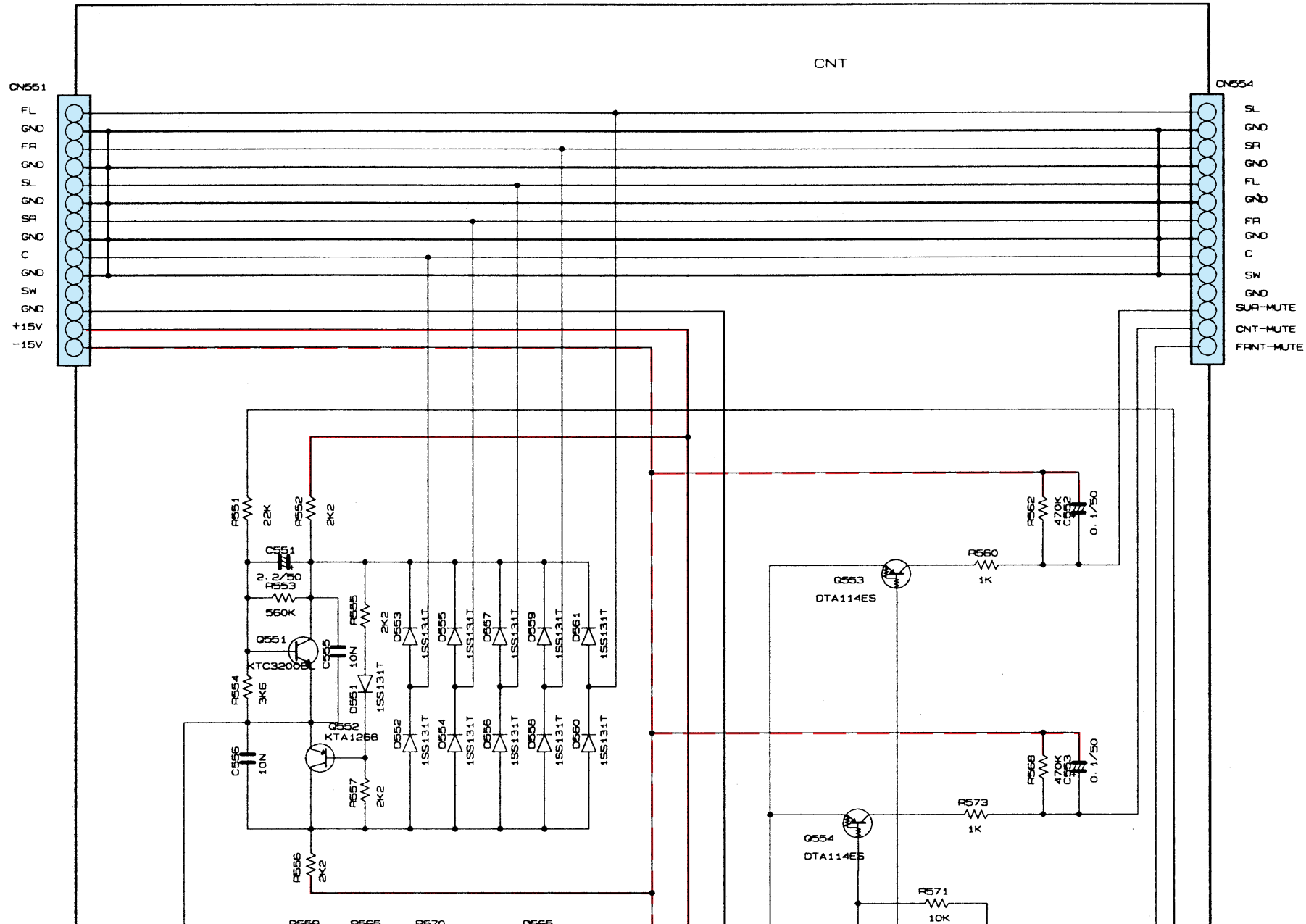

6

7

8

9

10

11

PRE-AMP

FL

SL

C

CP554

SL

GN

SR

GN

FL

GN

FR

GN

C

GN

SW

SUR-MUTE

CNT-MUTE

FRNT-MUTE

CN504

NF4

GN

FL

FL

CN501

-b

-b

GN

NF1

GN

SL

FL

CN503

NF3

NF3

GN

C

C

A

B

C

D

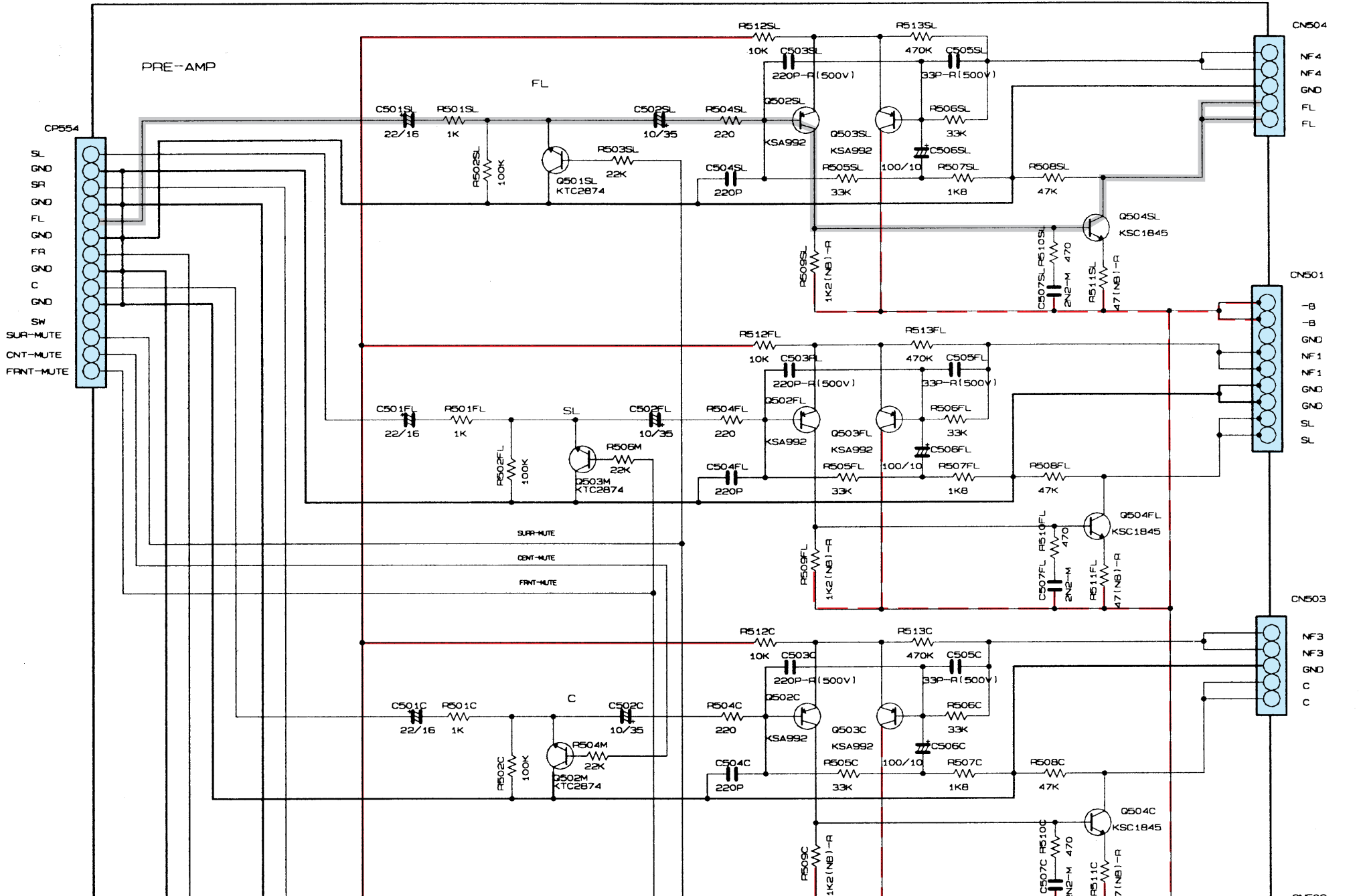

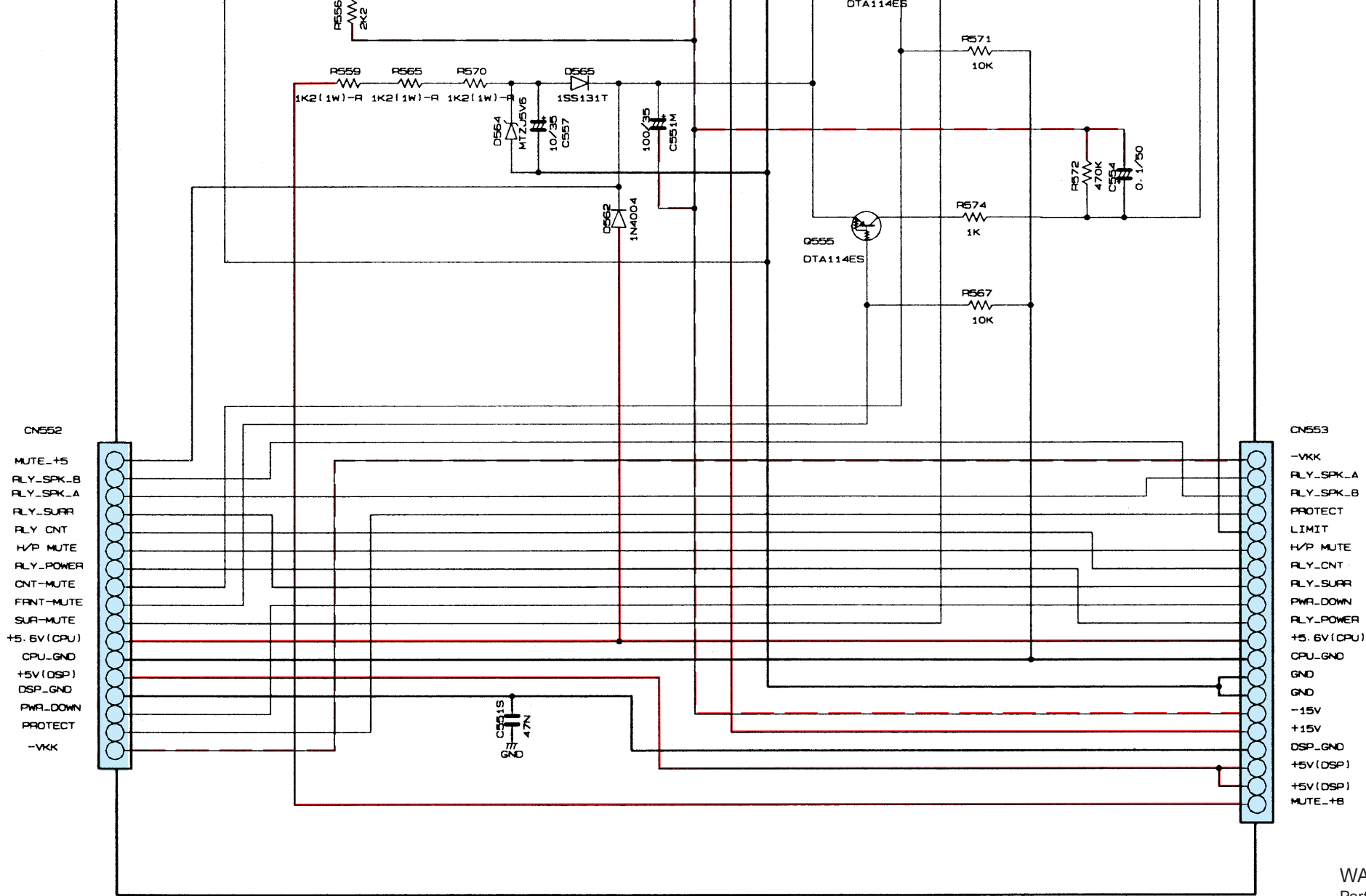

NOTICE
 ALL RESISTANCE VALUES IN OHM. k=1,000 OHM M=1,000,000 OHM
 ALL CAPACITANCE VALUES IN MICRO FARAD. P=MICRO-MICRO FARAD
 EACH VOLTAGE AND CURRENT ARE MEASURED AT NO SIGNAL INPUT
 CONDITION.
 CIRCUIT AND PARTS ARE SUBJECT TO CHANGE WITHOUT PRIOR
 NOTICE.

WA
 Parts
 Use
 CAU
 Befor
 leaka
 curre
 of the
 WA
 DO N
 corre

N553
 WKK
 LY_SPK_A
 LY_SPK_B
 PROTECT
 LIMIT
 P MUTE
 LY_CNT
 LY_SUAR
 NR_DOWN
 LY_POWER
 5.6V (CPU)
 PU_L_GND
 ND
 ND
 15V
 15V
 SP_GND
 5V (DSP)
 5V (DSP)
 MUTE_+B

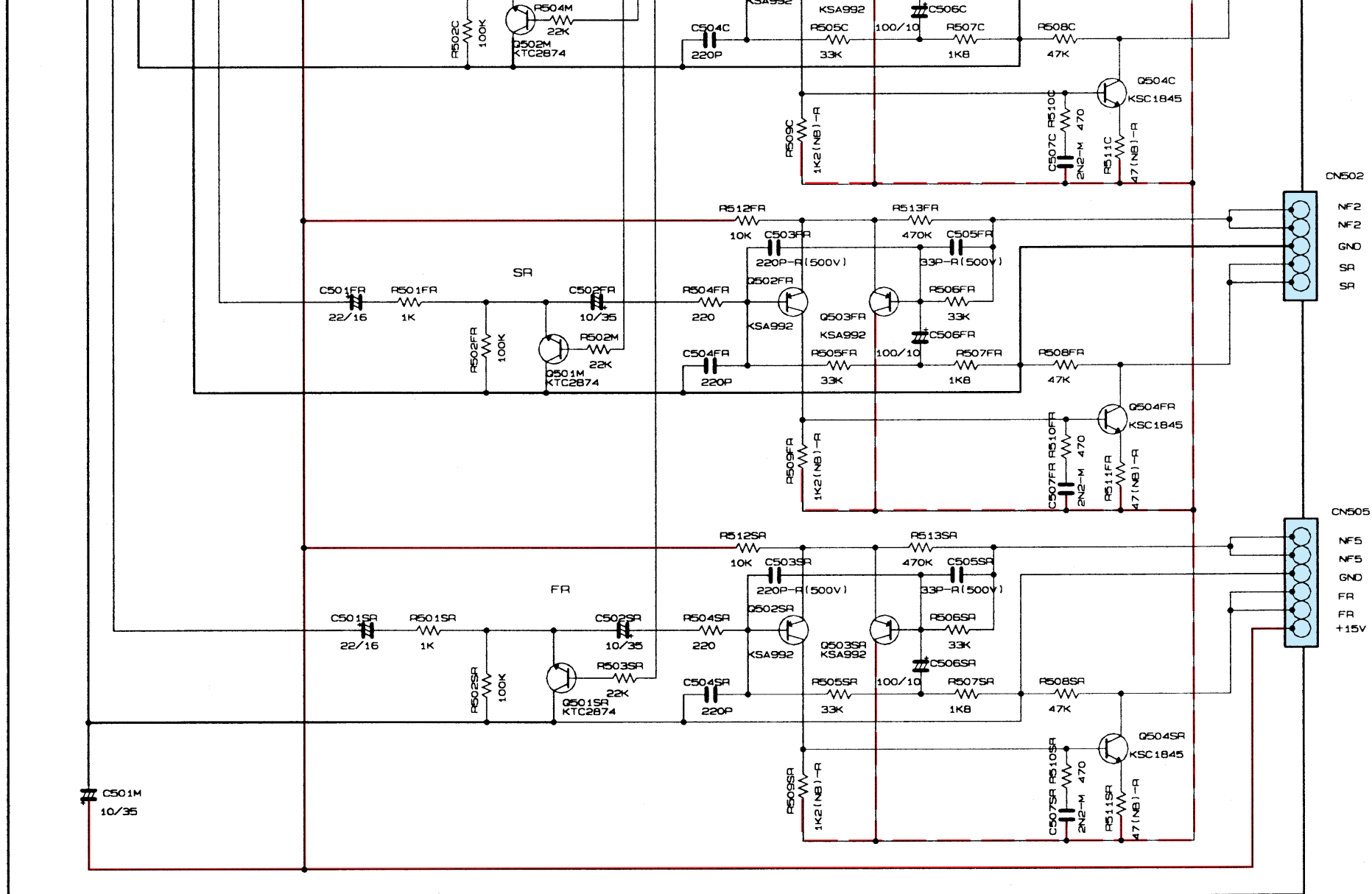

WARNING:
 Parts marked with this symbol have critical characteristics.
 Use ONLY replacement parts recommended by the manufacture.

CAUTION:
 Before returning the unit to the customer, make sure you make either (1) a leakage current check or (2) a line to chassis resistance check. If the leakage current exceeds 0.5 milliamps, or if the resistance from chassis to either side of the power card is less than 460kohms, the unit is defective.

WARNING:
 DO NOT return the unit to the customer until the problem is located and corrected.



SCHEMATIC DIAGRAMS(4/7)
 CNT P.W.B. UNIT
 PRE-AMP P.W.B. UNIT

D
 E
 F
 G
 H

SCHEMATIC DIAGRAMS(5/7)

1 2 3 4 5 6 7 8 9 10 11

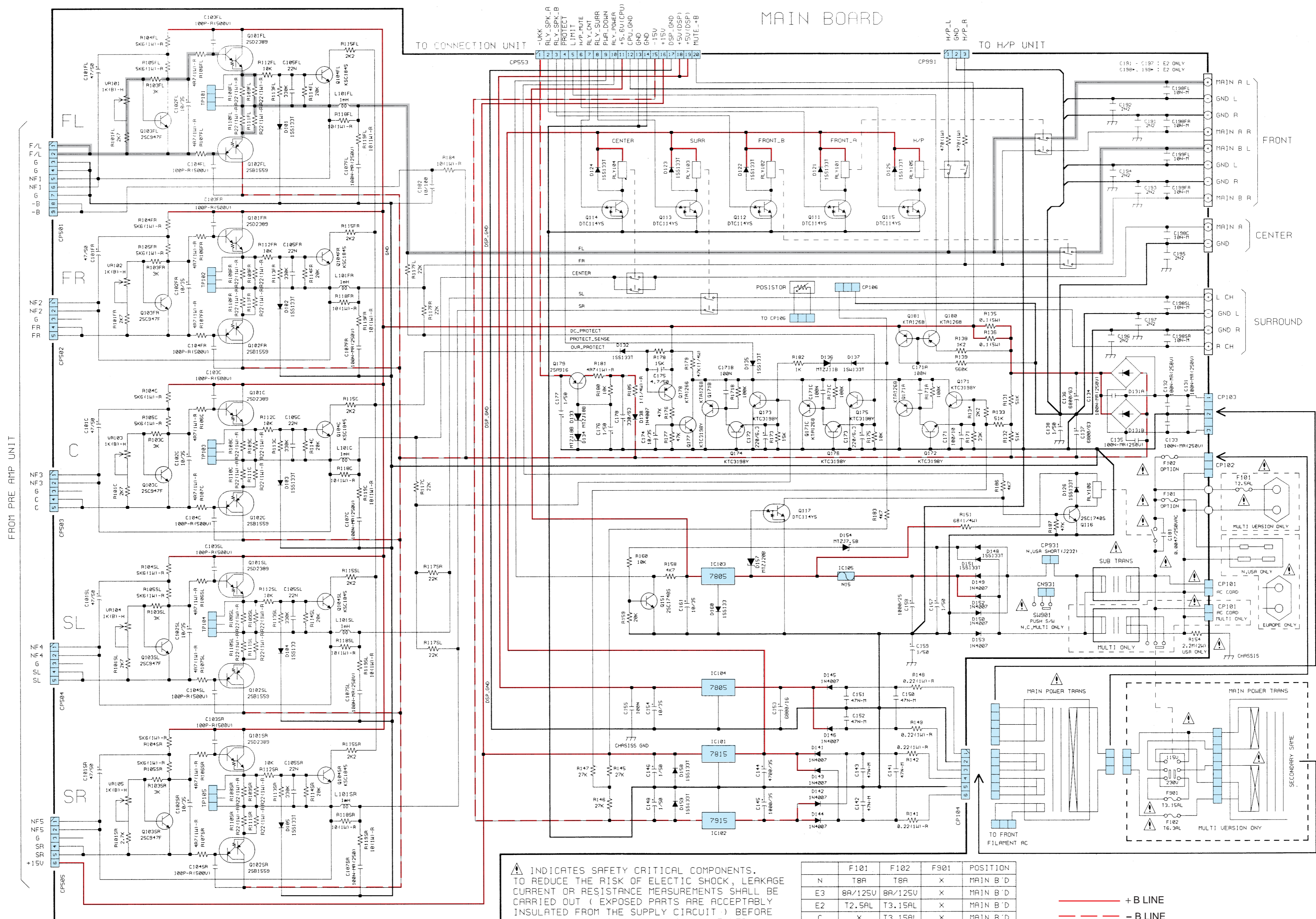

NOTICE
 ALL RESISTANCE VALUES IN OHM. k=1,000 OHM M=1,000,000 OHM
 ALL CAPACITANCE VALUES IN MICRO FARAD. P=MICRO-MICRO FARAD
 EACH VOLTAGE AND CURRENT ARE MEASURED AT MO SIGNAL INPUT
 CONDITION.
 CIRCUIT AND PARTS ARE SUBJECT TO CHANGE WITHOUT PRIOR
 NOTICE.

⚠ INDICATES SAFETY CRITICAL COMPONENTS.
 TO REDUCE THE RISK OF ELECTRIC SHOCK, LEAKAGE
 CURRENT OR RESISTANCE MEASUREMENTS SHALL BE
 CARRIED OUT (EXPOSED PARTS ARE ACCEPTABLY
 INSULATED FROM THE SUPPLY CIRCUIT) BEFORE
 THE APPLIANCE RETURNED TO THE CUSTOMER.

WARNING:
 Parts marked with this symbol ⚠ have critical characteristics.
 Use ONLY replacement parts recommended by the manufacturer.

CAUTION:
 Before returning the unit to the customer, make sure you make either (1) a
 leakage current check or (2) a line to chassis resistance check. If the leakage
 current exceeds 0.5 milliamps, or if the resistance from chassis to either side
 of the power cord is less than 460kohms, the unit is defective.

WARNING:
 DO NOT return the unit to the customer until the problem is located and
 corrected.

	F101	F102	F901	POSITION
N	T8A	T8A	X	MAIN B'D
E3	8A/125V	8A/125V	X	MAIN B'D
E2	T2.5AL	T3.15AL	X	MAIN B'D
C	X	T3.15AL	X	MAIN B'D
H,T,E1	T2.5AL	T6.3AL	T3.15AL	U. SEL B'D

— + B LINE
 — - B LINE
 — SIGNAL LINE

SCHEMATIC DIAGRAMS(5/7)
 MAIN P.W.B. UNIT

SCHEMATIC DIAGRAMS(5/7)

1 2 3 4 5 6 7 8 9 10 11

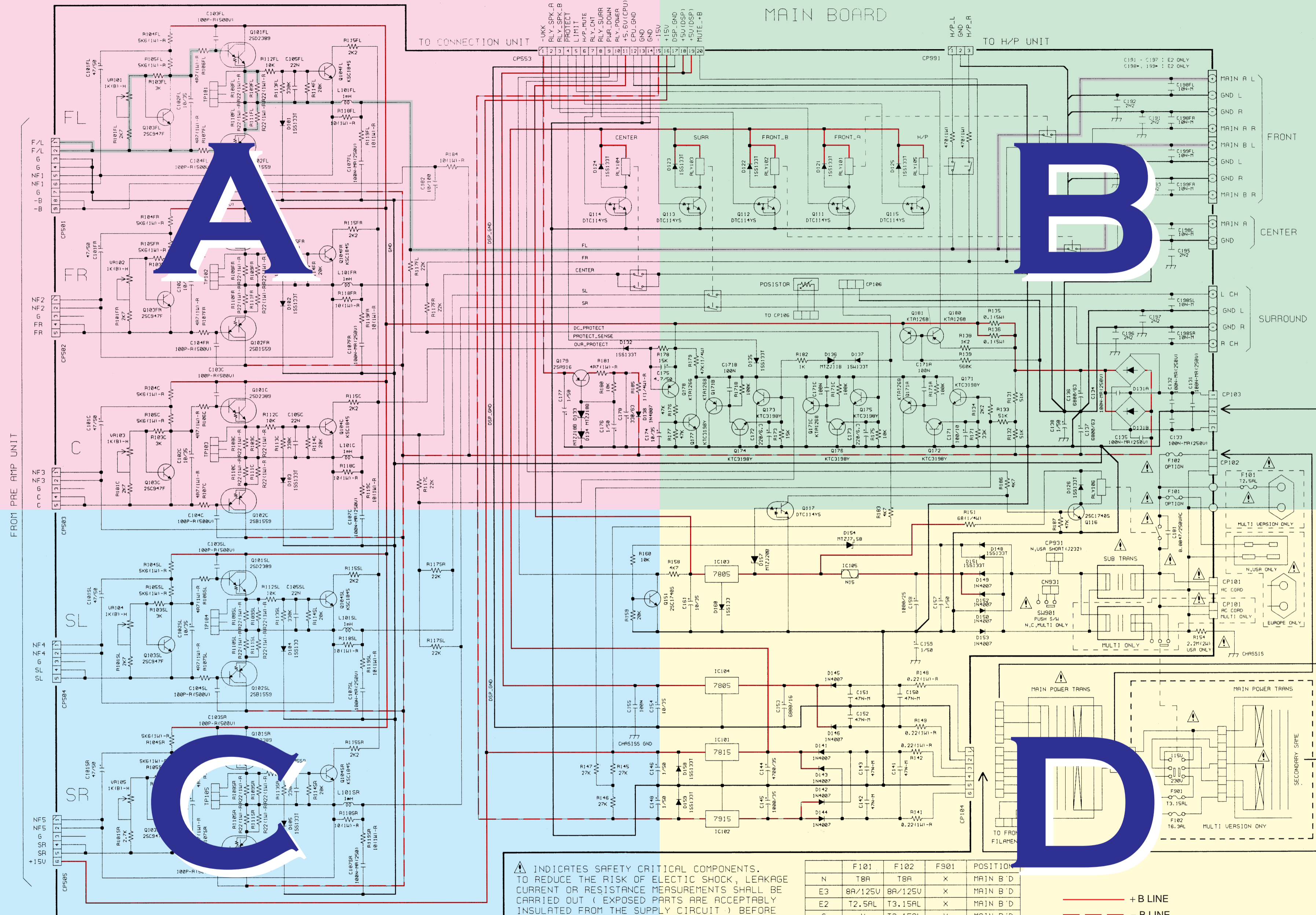

A

B

C

D

⚠ INDICATES SAFETY CRITICAL COMPONENTS. TO REDUCE THE RISK OF ELECTRIC SHOCK, LEAKAGE CURRENT OR RESISTANCE MEASUREMENTS SHALL BE CARRIED OUT (EXPOSED PARTS ARE ACCEPTABLY INSULATED FROM THE SUPPLY CIRCUIT) BEFORE THE APPLIANCE RETURNED TO THE CUSTOMER.

	F101	F102	F901	POSITION
N	T8A	T8A	X	MAIN B'D
E3	8A/125V	8A/125V	X	MAIN B'D
E2	T2.5AL	T3.15AL	X	MAIN B'D
C	X	T3.15AL	X	MAIN B'D
H, T, E1	T2.5AL	T6.3AL	T3.15AL	U. SEL B'D

— + B LINE
 - - - - - B LINE
 ——— SIGNAL LINE

NOTICE
 ALL RESISTANCE VALUES IN OHM. k=1,000 OHM M=1,000,000 OHM
 ALL CAPACITANCE VALUES IN MICRO FARAD. P=MICRO-MICRO FARAD
 EACH VOLTAGE AND CURRENT ARE MEASURED AT MO SIGNAL INPUT CONDITION.
 CIRCUIT AND PARTS ARE SUBJECT TO CHANGE WITHOUT PRIOR NOTICE.

WARNING:
 Parts marked with this symbol ⚠ have critical characteristics. Use ONLY replacement parts recommended by the manufacture.

CAUTION:
 Before returning the unit to the customer, make sure you make either (1) a leakage current check or (2) a line to chassis resistance check. If the leakage current exceeds 0.5 milliamps, or if the resistance from chassis to either side of the power card is less than 460kohms, the unit is defective.

WARNING:
 DO NOT return the unit to the customer until the problem is located and corrected.

SCHEMATIC DIAGRAMS(5/7)
MAIN P.W.B. UNIT

SCHEMATIC DIAGRAMS(5/7)

1

2

3

4

5

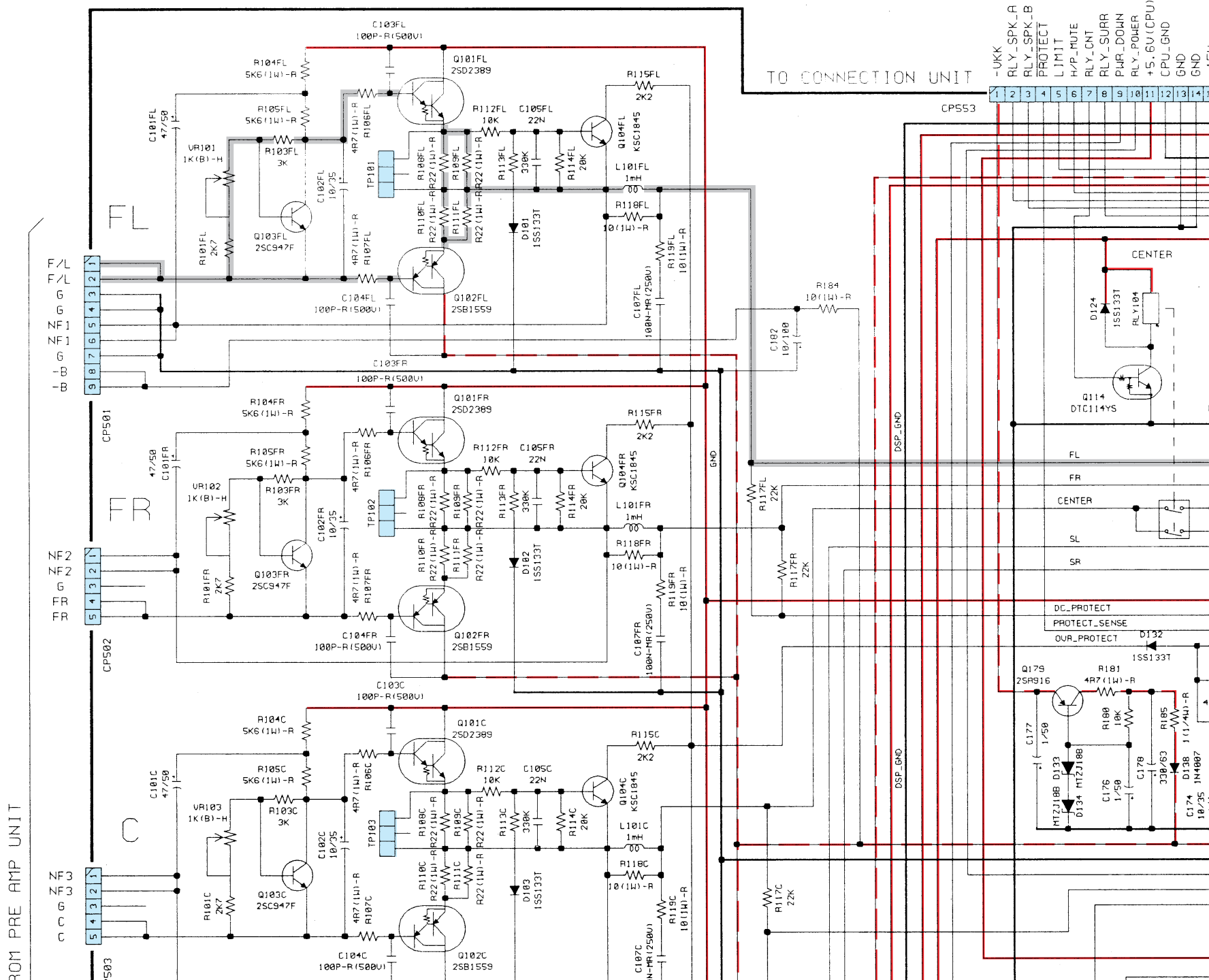

6 7 8 9 10 11

MAIN BOARD

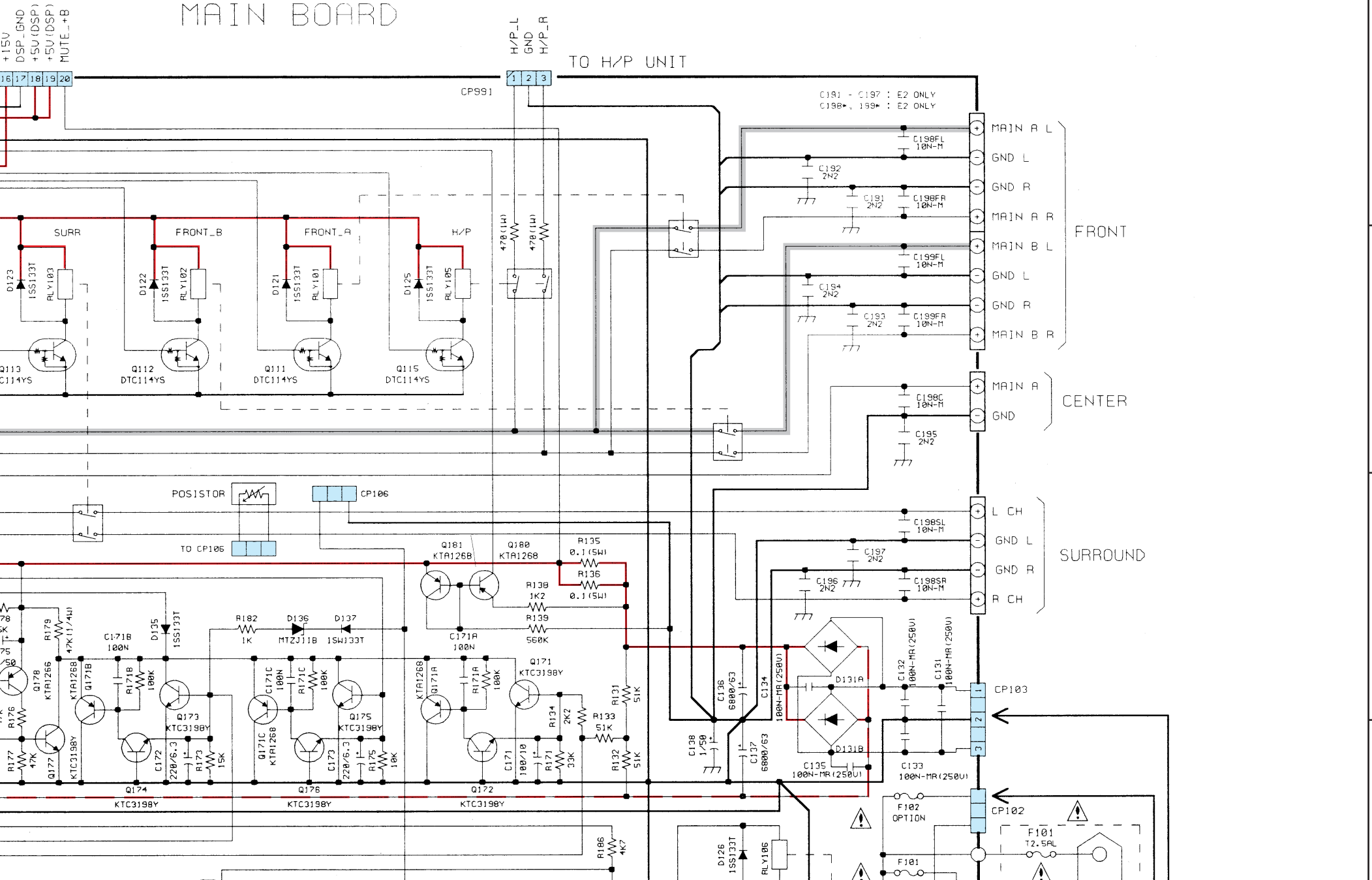

A
B
C
D

TO H/P UNIT

FRONT

CENTER

SURROUND

C191 - C197 : E2 ONLY
C198, 199 : E2 ONLY

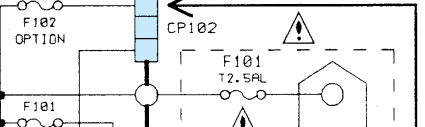

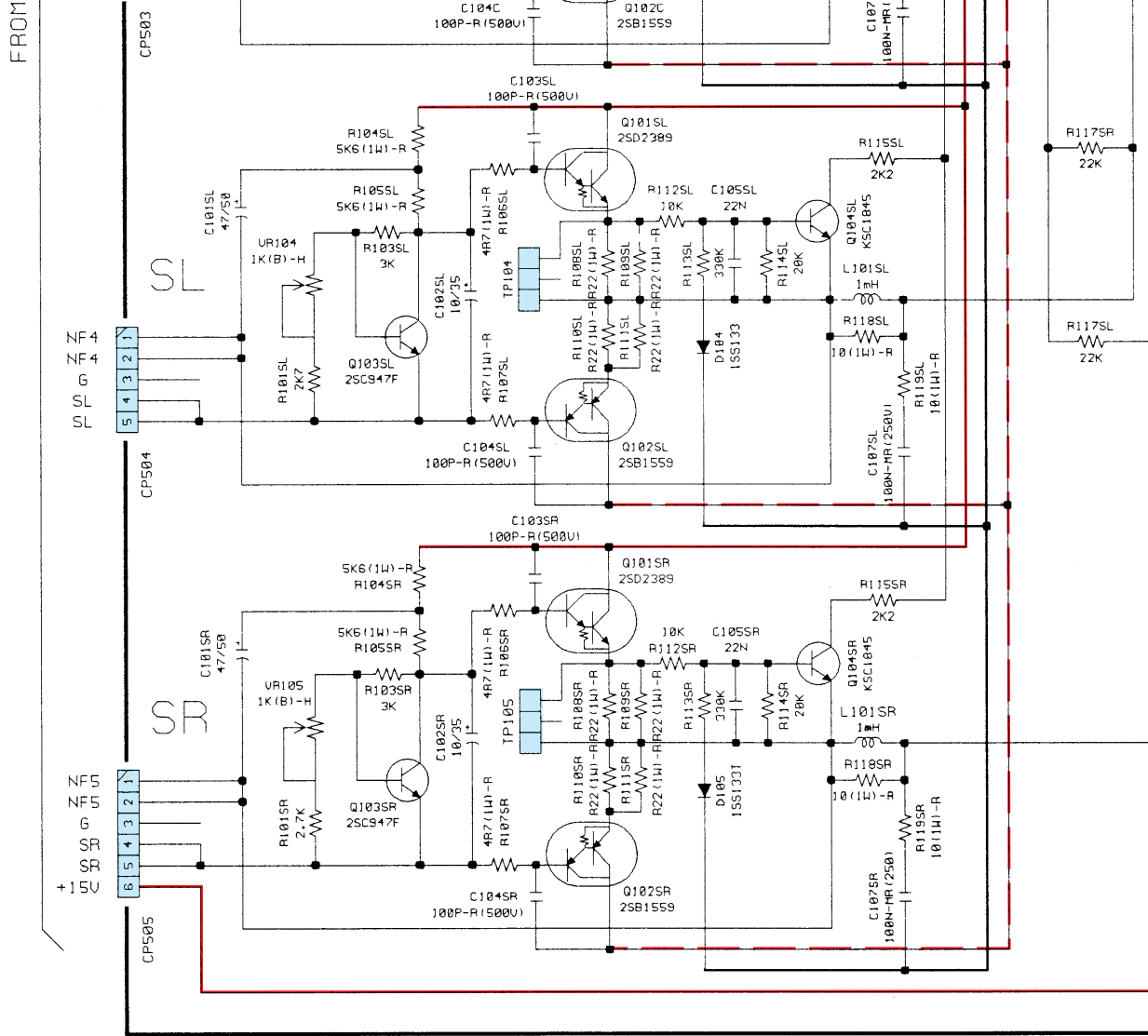

FROM

NF 4
NF 4
G
SL
SL

NF 5
NF 5
G
SR
SR
+15V

NOTICE

ALL RESISTANCE VALUES IN OHM. k=1,000 OHM M=1,000,000 OHM
 ALL CAPACITANCE VALUES IN MICRO FARAD. P=MICRO-MICRO FARAD
 EACH VOLTAGE AND CURRENT ARE MEASURED AT MO SIGNAL INPUT
 CONDITION.
 CIRCUIT AND PARTS ARE SUBJECT TO CHANGE WITHOUT PRIOR
 NOTICE.

⚠ INDICATES SAFETY C
 TO REDUCE THE RISK OF
 CURRENT OR RESISTANCE
 CARRIED OUT (EXPOSED
 INSULATED FROM THE SU
 THE APPLIANCE RETURN

WARNING:

Parts marked with this symbol /
 Use ONLY replacement parts re

CAUTION:

Before returning the unit to the c
 leakage current check or (2) a li
 current exceeds 0.5 milliamps,
 of the power card is less than 4

WARNING:

DO NOT return the unit to the c
 corrected.

DSP_GND

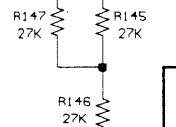
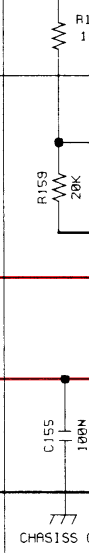

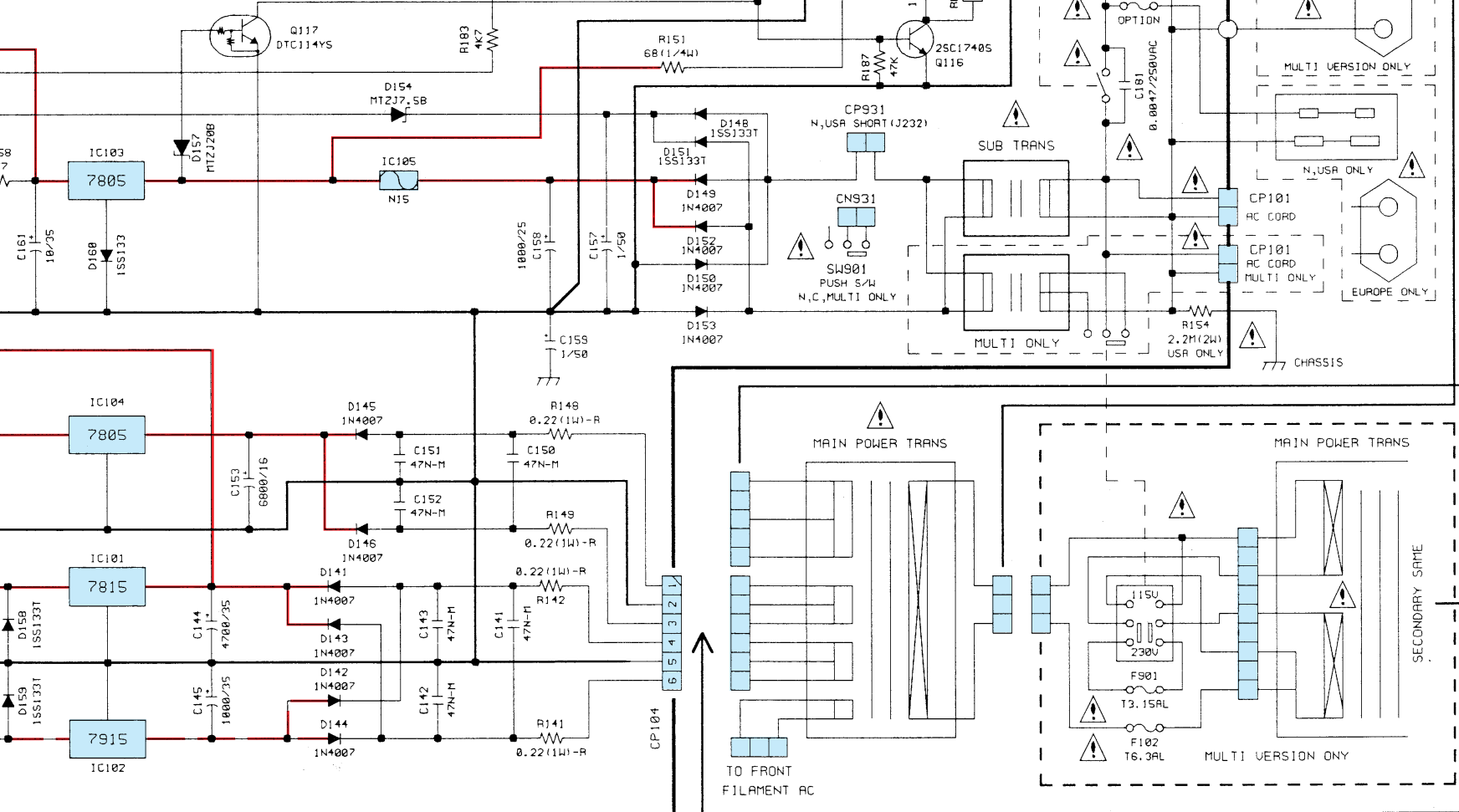

AL COMPONENTS.
 CTIC SHOCK, LEAKAGE
 UREMENTS SHALL BE
 S ARE ACCEPTABLY
 CIRCUIT) BEFORE
 THE CUSTOMER.

	F101	F102	F901	POSITION
N	T8A	T8A	X	MAIN B'D
E3	8A/125V	8A/125V	X	MAIN B'D
E2	T2.5AL	T3.15AL	X	MAIN B'D
C	X	T3.15AL	X	MAIN B'D
H,T,E1	T2.5AL	T6.3AL	T3.15AL	U.SEL B'D

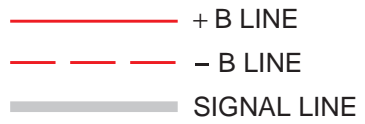

ve critical characteristics.
 ded by the manufacture.

, make sure you make either (1) a
 assis resistance check. If the leakage
 esistance from chassis to either side
 , the unit is defective.

until the problem is located and

SCHEMATIC DIAGRAMS(5/7) MAIN P.W.B. UNIT

E
 F
 G
 H

SCHEMATIC DIAGRAMS(6/7)

1 2 3 4 5 6 7 8 9 10 11

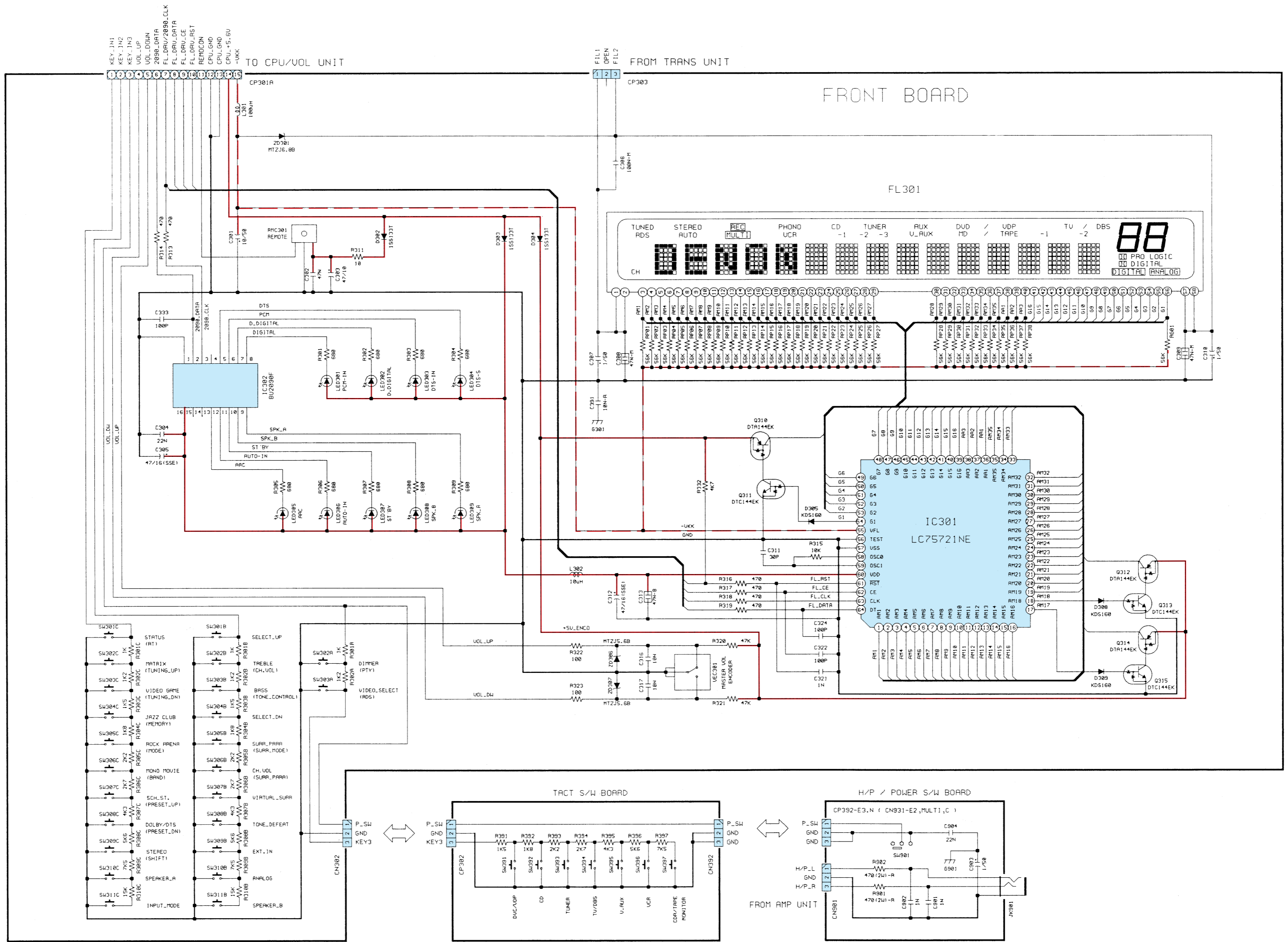

ALL RESISTANCE VALUES IN OHM. K=1,000 OHM M=1,000,000 OHM
 ALL CAPACITANCE VALUES IN MICRO FARAD. P=MICRO-MICRO FARAD
 EACH VOLTAGE AND CURRENT ARE MEASURED AT MO SIGNAL INPUT
 CONDITION.
 CIRCUIT AND PARTS ARE SUBJECT TO CHANGE WITHOUT PRIOR
 NOTICE.

WARNING:
 Parts marked with this symbol have critical characteristics.
 Use ONLY replacement parts recommended by the manufacture.

CAUTION:
 Before returning the unit to the customer, make sure you make either (1) a
 leakage current check or (2) a line to chassis resistance check. If the leakage
 current exceeds 0.5 milliamps, or if the resistance from chassis to either side of
 the power card is less than 460kohms, the unit is defective.

WARNING:
 DO NOT return the unit to the customer until the problem is located and
 corrected.

— + B LINE
 - - - - -B LINE

SCHEMATIC DIAGRAMS(6/7)
 FRONT P.W.B. UNIT
 TACT S/W P.W.B. UNIT
 H/P & POWER S/W P.W.B. UNIT

SCHEMATIC DIAGRAMS(6/7)

1 2 3 4 5 6 7 8 9 10 11

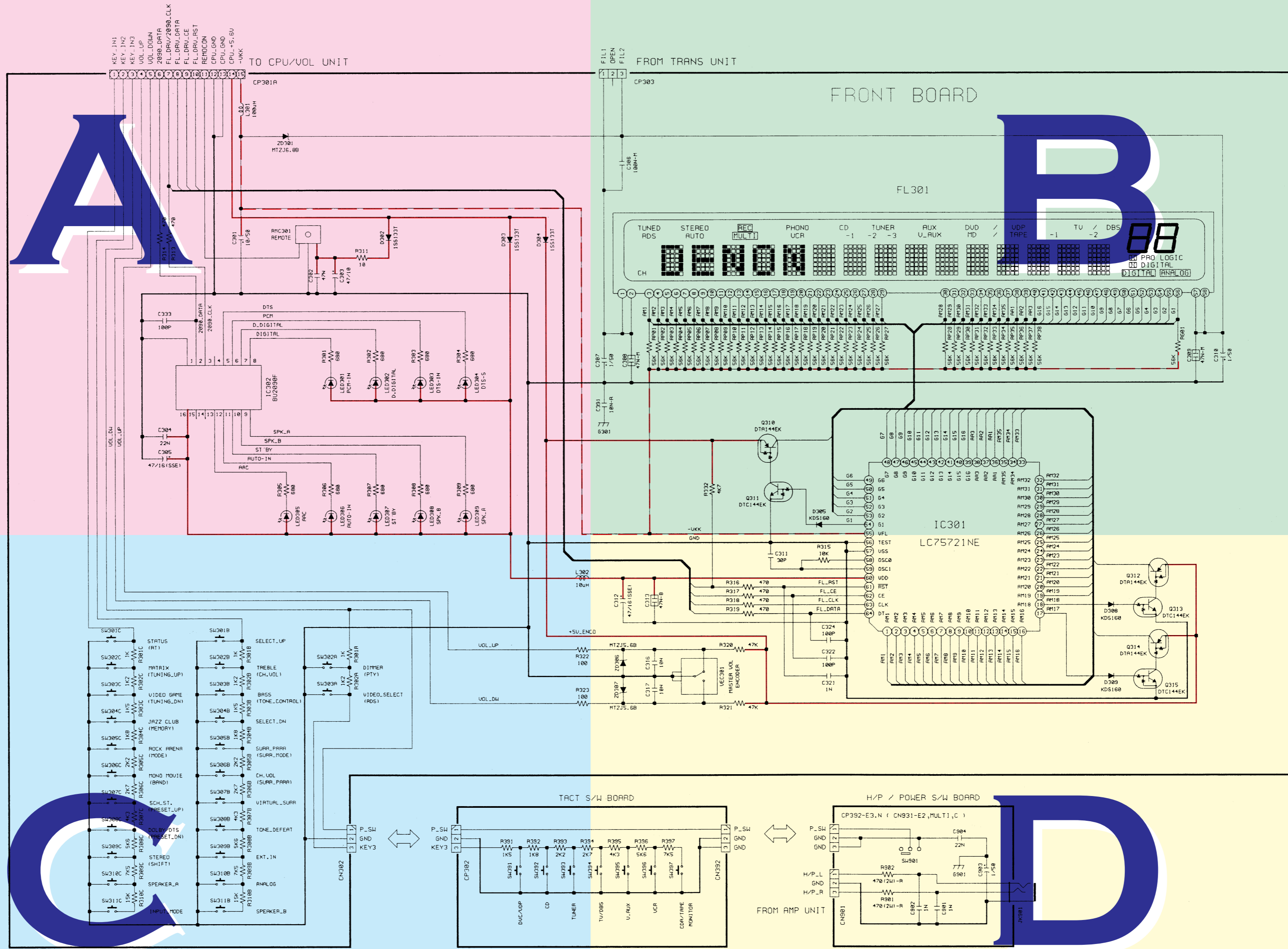

ALL RESISTANCE VALUES IN OHM. k=1,000 OHM M=1,000,000 OHM
 ALL CAPACITANCE VALUES IN MICRO FARAD. P=MICRO-MICRO FARAD
 EACH VOLTAGE AND CURRENT ARE MEASURED AT MO SIGNAL INPUT
 CONDITION.
 CIRCUIT AND PARTS ARE SUBJECT TO CHANGE WITHOUT PRIOR
 NOTICE.

WARNING:
 Parts marked with this symbol  have critical characteristics.
 Use ONLY replacement parts recommended by the manufacture.

CAUTION:
 Before returning the unit to the customer, make sure you make either (1) a
 leakage current check or (2) a line to chassis resistance check. If the leakage
 current exceeds 0.5 milliamps, or if the resistance from chassis to either side
 of the power card is less than 460kohms, the unit is defective.

WARNING:
 DO NOT return the unit to the customer until the problem is located and
 corrected.

— + B LINE
 - - - - - B LINE

SCHEMATIC DIAGRAMS(6/7)
 FRONT P.W.B. UNIT
 TACT S/W P.W.B. UNIT
 H/P & POWER S/W P.W.B. UNIT

SCHEMATIC DIAGRAMS(6/7)

1

2

3

4

5

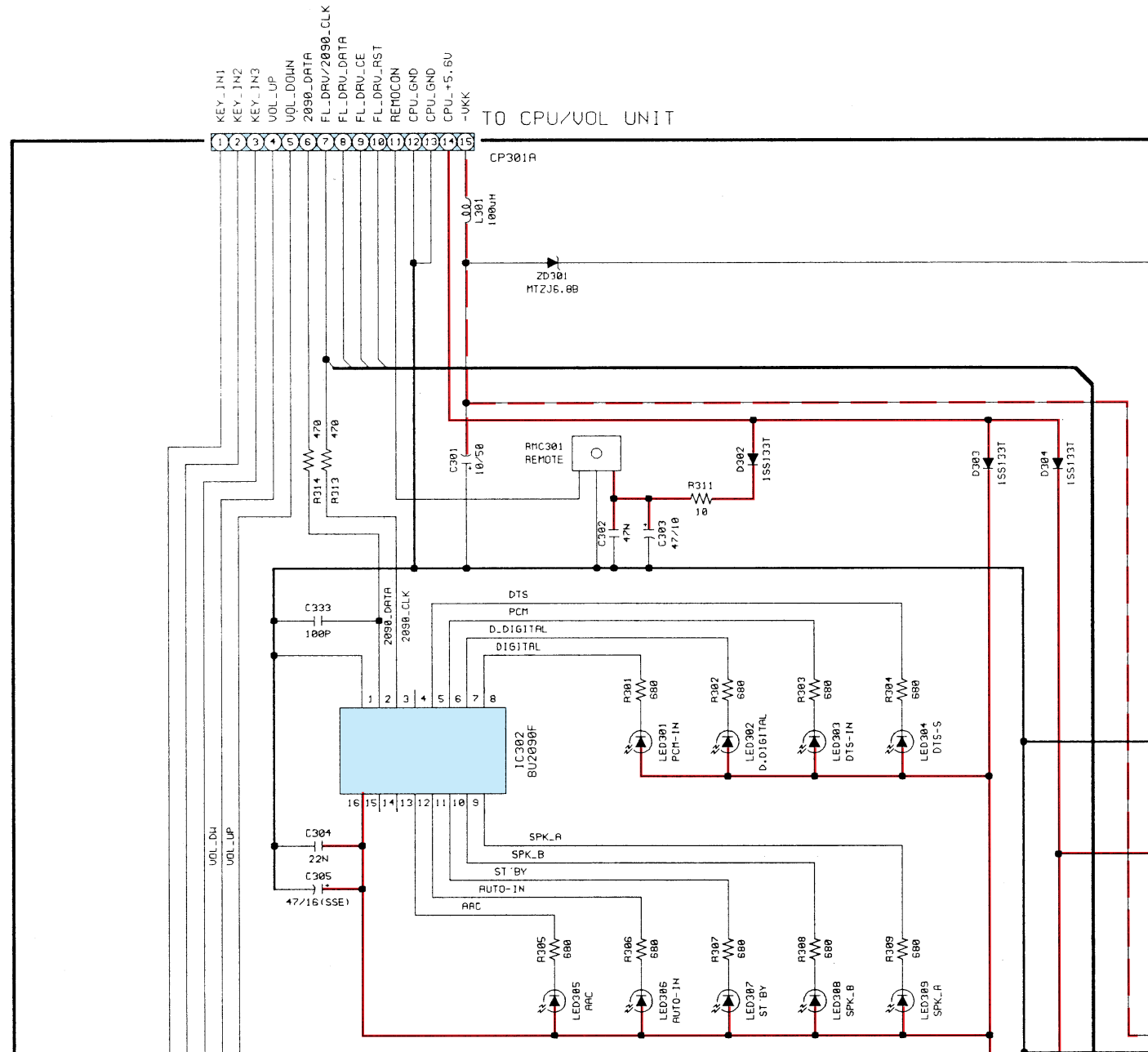

6 7 8 9 10 11

A
B
C
D

FIL1
OPEN
FIL2
FROM TRANS UNIT
1 2 3

CP303

FRONT BOARD

FL301

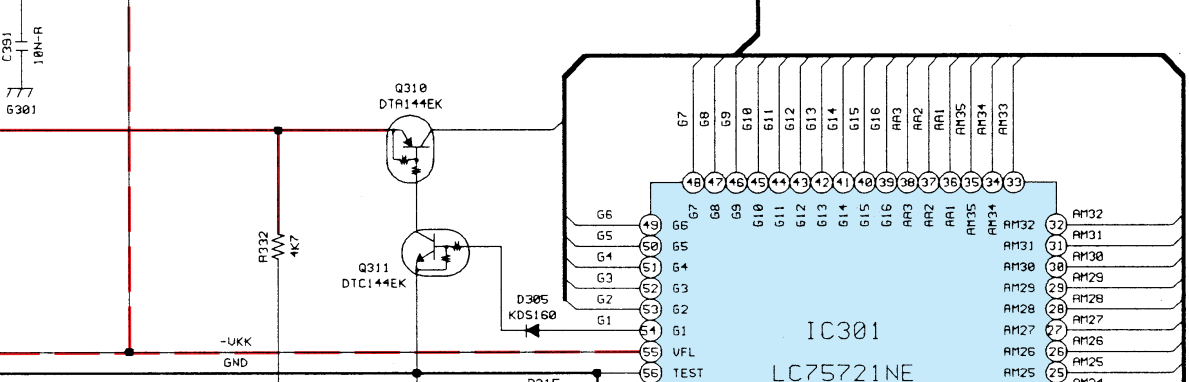
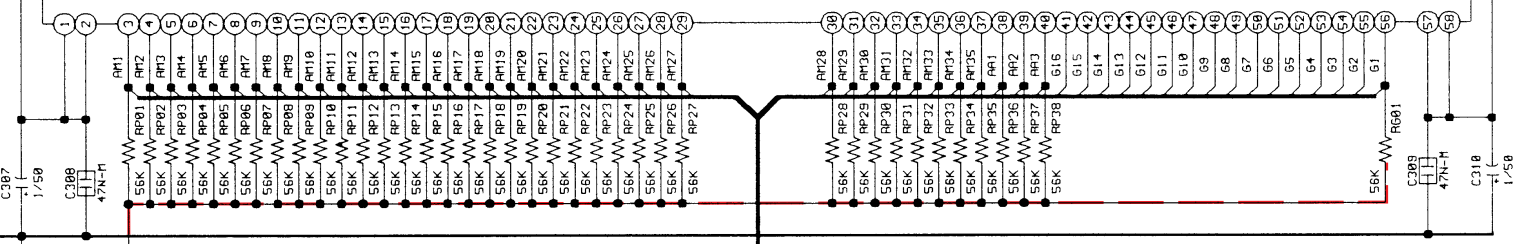
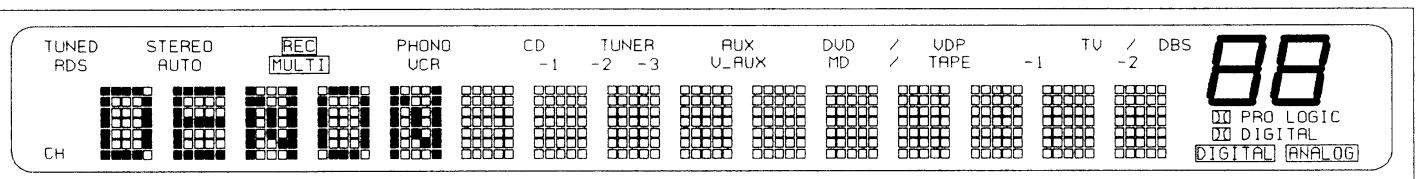

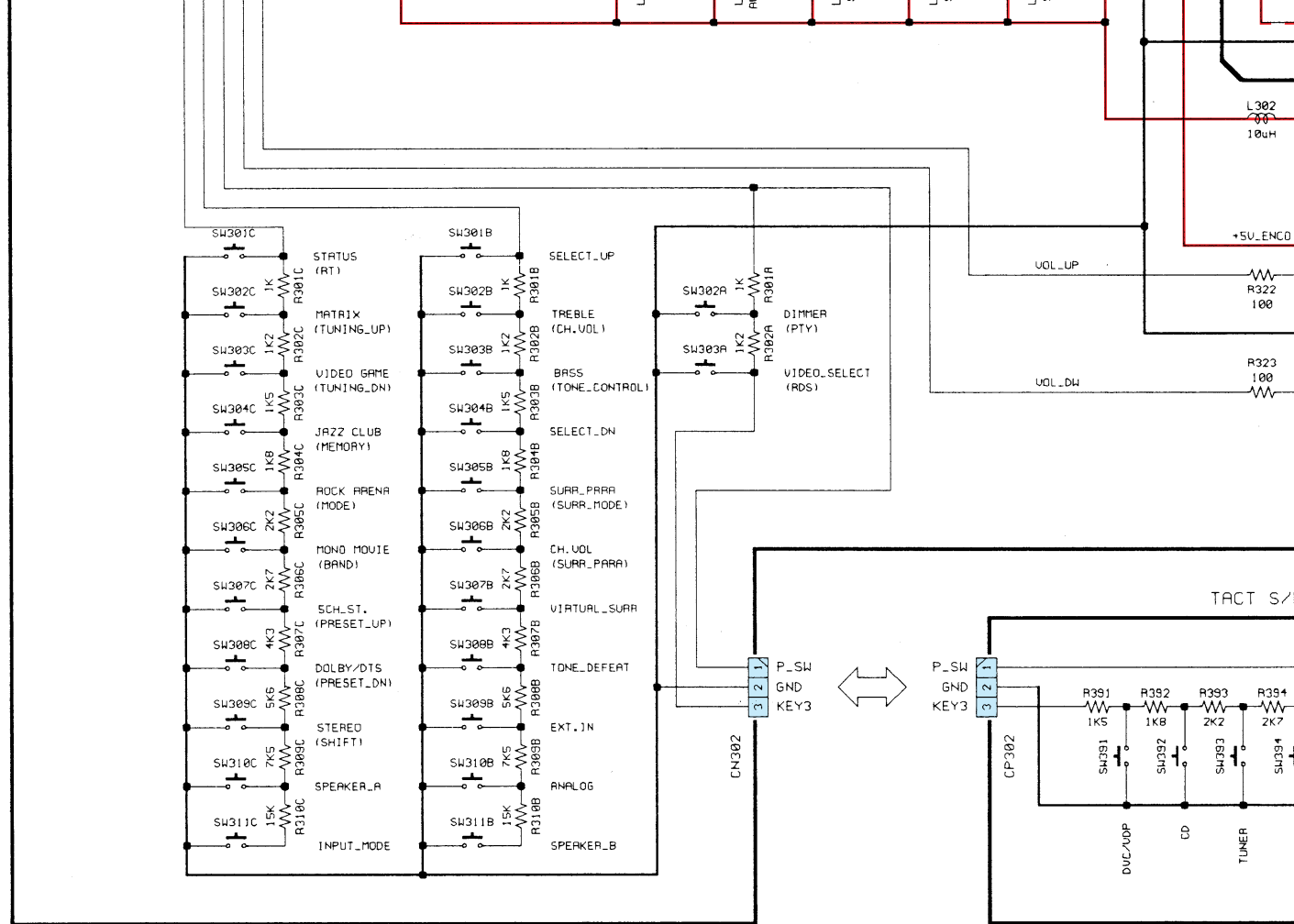

ALL RESISTANCE VALUES IN OHM. k=1,000 OHM M=1,000,000 OHM
 ALL CAPACITANCE VALUES IN MICRO FARAD. P=MICRO-MICRO FARAD
 EACH VOLTAGE AND CURRENT ARE MEASURED AT MO SIGNAL INPUT
 CONDITION.
 CIRCUIT AND PARTS ARE SUBJECT TO CHANGE WITHOUT PRIOR
 NOTICE.

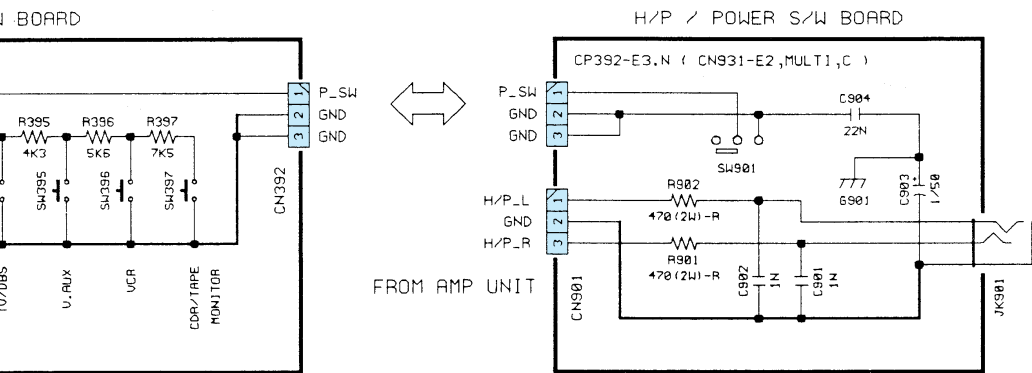
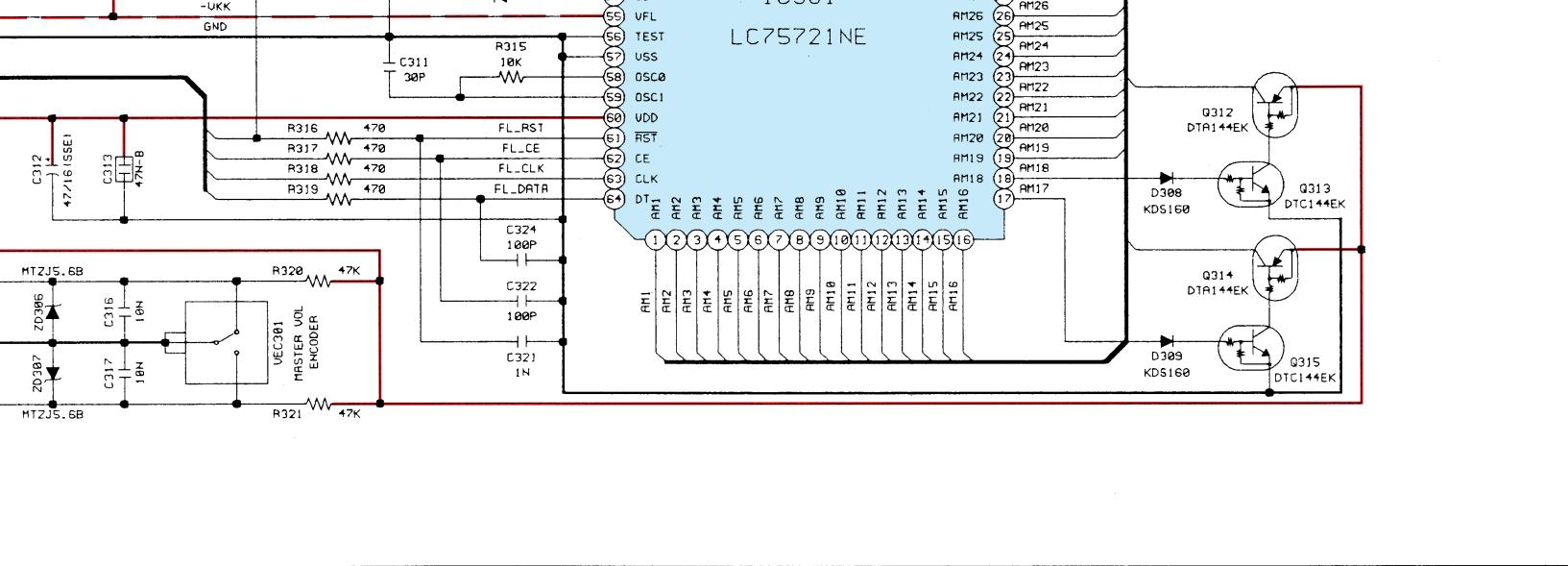

——— + B LINE
- - - - - B LINE

WARNING:
 Parts marked with this symbol have critical characteristics.
 Use ONLY replacement parts recommended by the manufacture.

CAUTION:
 Before returning the unit to the customer, make sure you make either (1) a leakage current check or (2) a line to chassis resistance check. If the leakage current exceeds 0.5 milliamps, or if the resistance from chassis to either side of the power card is less than 460kohms, the unit is defective.

WARNING:
 DO NOT return the unit to the customer until the problem is located and corrected.

SCHEMATIC DIAGRAMS(6/7)
 FRONT P.W.B. UNIT
 TACT S/W P.W.B. UNIT
 H/P & POWER S/W P.W.B. UNIT

E

F

G

H

SCHEMATIC DIAGRAMS(7/7)

1 2 3 4 5 6 7 8 9 10 11

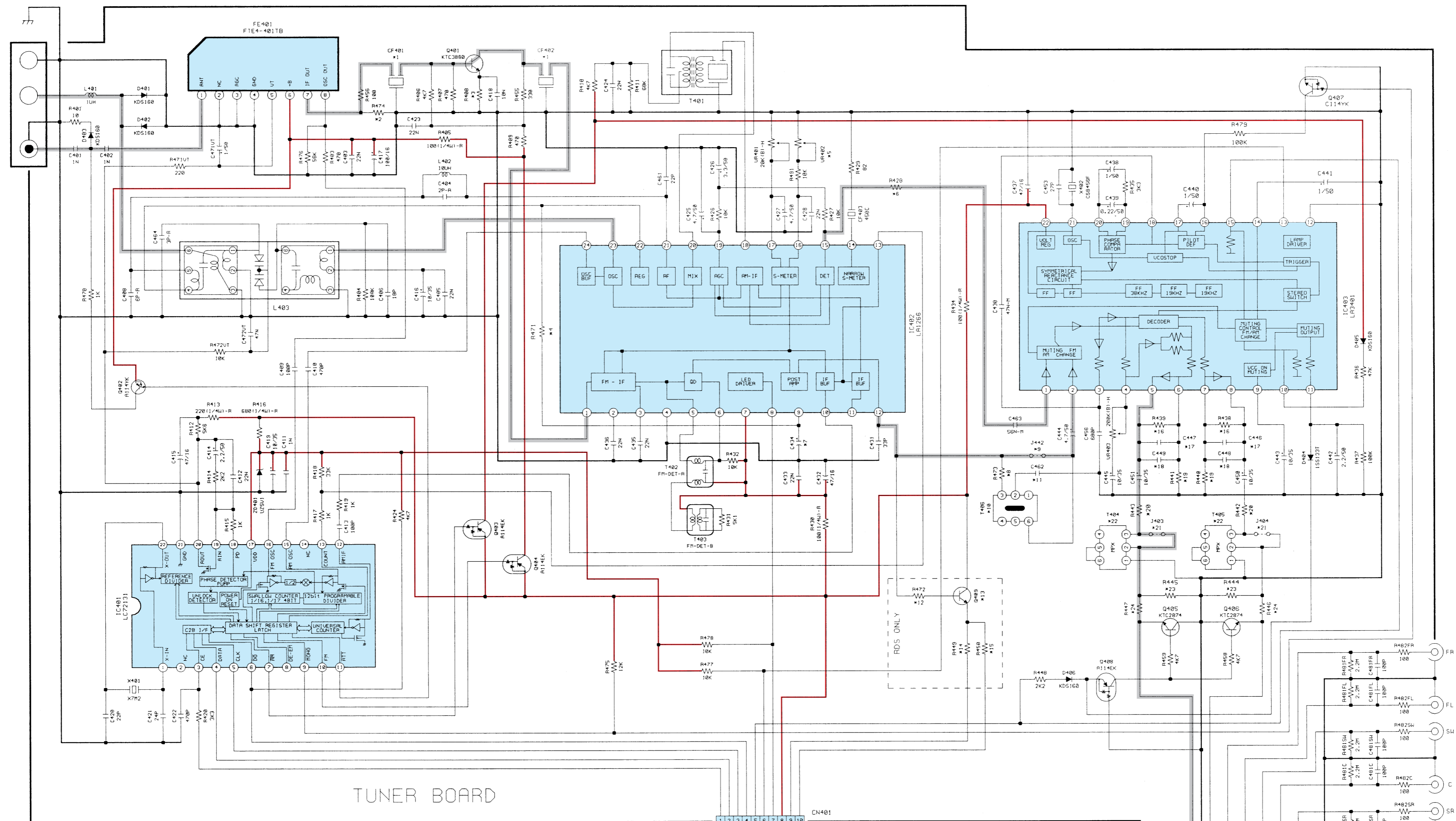

TUNER BOARD

R-NO.	USA (E3)	EUROPE (E2)	MULTI, CHINA
*1	CF401/CF402	SFE10.7MAB	SFE10.7MS3
*2	R474	-	100
*3	R407/R408	470/1.2K	620/680
*4	R471	18K	39K
*5	UR402	50KB	100KB
*6	R428	3.3K	10K
*7	C434	1/50	0.33/50
*8	R473	-	2.4K

R-NO.	USA (E3)	EUROPE (E2)	MULTI, CHINA
*9	J442	JUMPER	-
*10	T406	-	ANTI-BIADIE
*11	C462	-	470P
*12	R472	-	100
*13	Q409	-	KTC3880
*14	R449	-	3.9K
*15	R450	-	1K
*16	R438, R439	100K	150K

R-NO.	USA (E3)	EUROPE (E2)	MULTI, CHINA
*17	C446, C447	270P	330P
*18	C448, C449	470P	-
*19	R440, R441	120K	220K
*20	R442, R443	3.3K	2.2K
*21	J403, J404	JUMPER	-
*22	T404, T405	-	LPF (MPX)
*23	R444, R445	8.2K	3.3K
*24	R446, R447	JUMPER	470

NOTICE
 ALL RESISTANCE VALUES IN OHM. K=1,000 OHM M=1,000,000 OHM
 ALL CAPACITANCE VALUES IN MICRO FARAD. P=MICRO-MICRO FARAD
 EACH VOLTAGE AND CURRENT ARE MEASURED AT MO SIGNAL INPUT
 CONDITION.
 CIRCUIT AND PARTS ARE SUBJECT TO CHANGE WITHOUT PRIOR
 NOTICE.

WARNING:
 Parts marked with this symbol Δ have critical characteristics.
 Use ONLY replacement parts recommended by the manufacturer.
CAUTION:
 Before returning the unit to the customer, make sure you make either (1) a
 leakage current check or (2) a line to chassis resistance check. If the leakage
 current exceeds 0.5 milliamps, or if the resistance from chassis to either side
 of the power card is less than 460kohms, the unit is defective.
WARNING:
 DO NOT return the unit to the customer until the problem is located and
 corrected.

— + B LINE
 — SIGNAL LINE

SCHEMATIC DIAGRAMS(7/7)
 TUNER P.W.B. UNIT

SCHEMATIC DIAGRAMS(7/7)

1 2 3 4 5 6 7 8 9 10 11

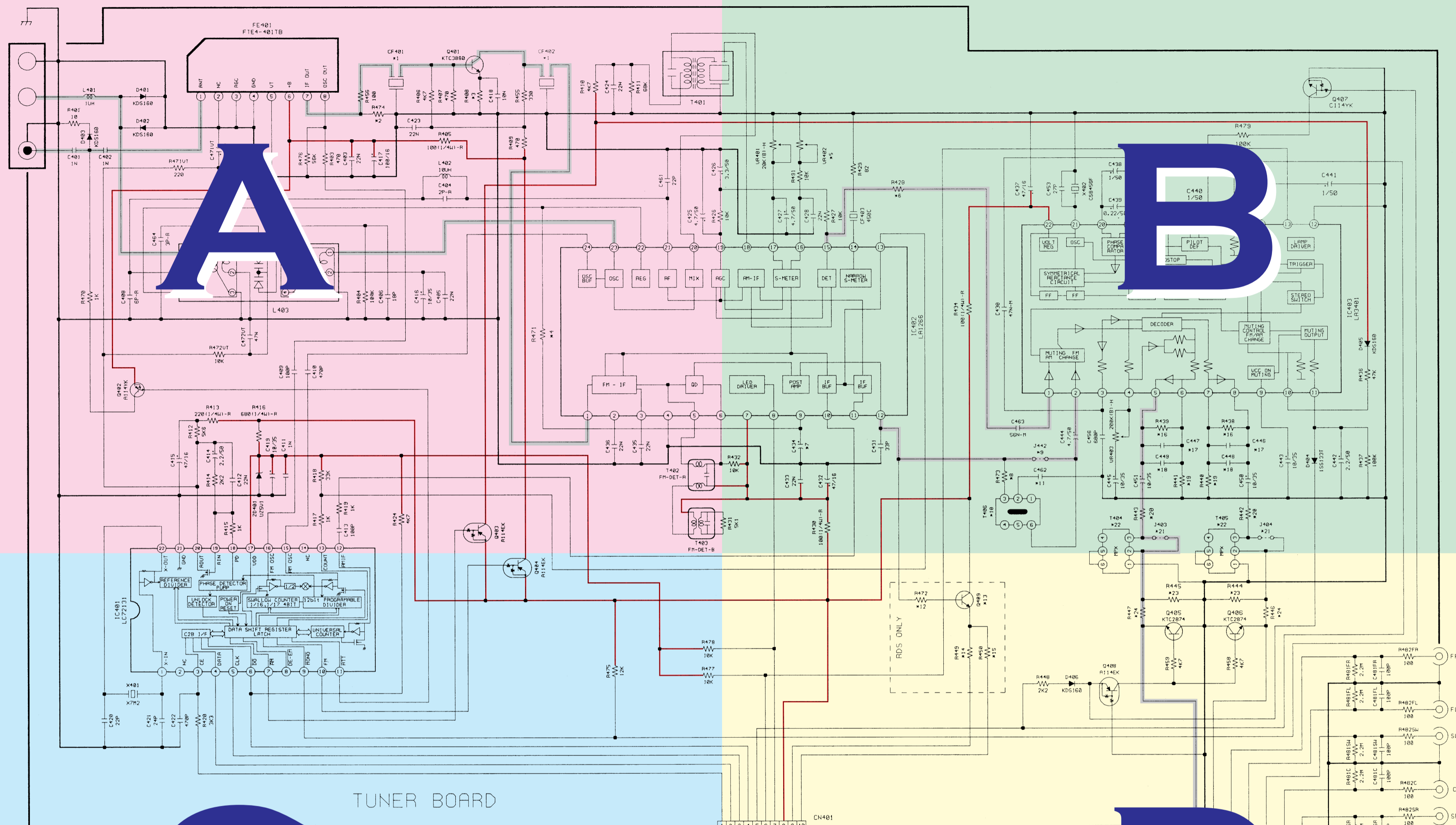

TUNER BOARD

R-NO.	EUROPE (E2)	MULTI, CHINA
*1	CF401/CF402	SFE10.7MS3 10.7MAB/MS3
*2	R474	180
*3	R407/R408	520/680 220/1.2K
*4	R471	20K 19K
*5	UR402	50KB 50KB
*6	R428	3.3K 10K 6.8K
*7	C434	1/50 0.33/50 0.33/50
*8	R473	2.4K

R-NO.	USA (E3)	EUROPE (E2)	MULTI, CHINA
*9	J442	JUMPER	JUMPER
*10	T406	ANTI-BIRDIE	-
*11	C462	470P	-
*12	R472	100	-
*13	Q409	KTC3880	-
*14	R449	3.9K	-
*15	R450	1K	-
*16	R438, R439	100K 150K	100K

R-NO.	USA (E3)	EUROPE (E2)	MULTI, CHINA
*17	C446, C447	270P 330P	180P
*18	C448, C449	470P	330P
*19	R440, R441	120K 220K	120K
*20	R442, R443	3.3K 2.2K	3.3K
*21	J403, J404	JUMPER	JUMPER
*22	T404, T405	LFP (1MPX)	-
*23	R444, R445	8.2K 3.3K	8.2K
*24	R446, R447	JUMPER	JUMPER

NOTICE
 ALL RESISTANCE VALUES IN OHM. k=1,000 OHM M=1,000,000 OHM
 ALL CAPACITANCE VALUES IN MICRO FARAD. P=MICRO-MICRO FARAD
 EACH VOLTAGE AND CURRENT ARE MEASURED AT MO SIGNAL INPUT
 CONDITION.
 CIRCUIT AND PARTS ARE SUBJECT TO CHANGE WITHOUT PRIOR
 NOTICE.

WARNING:
 Parts marked with this symbol Δ have critical characteristics.
 Use ONLY replacement parts recommended by the manufacturer.
CAUTION:
 Before returning the unit to the customer, make sure you make either (1) a
 leakage current check or (2) a line to chassis resistance check. If the leakage
 current exceeds 0.5 milliamps, or if the resistance from chassis to either side
 of the power card is less than 460kohms, the unit is defective.
WARNING:
 DO NOT return the unit to the customer until the problem is located and
 corrected.

— + B LINE
 — SIGNAL LINE

SCHEMATIC DIAGRAMS(7/7)
 TUNER P.W.B. UNIT

SCHEMATIC DIAGRAMS(7/7)

1

2

3

4

5

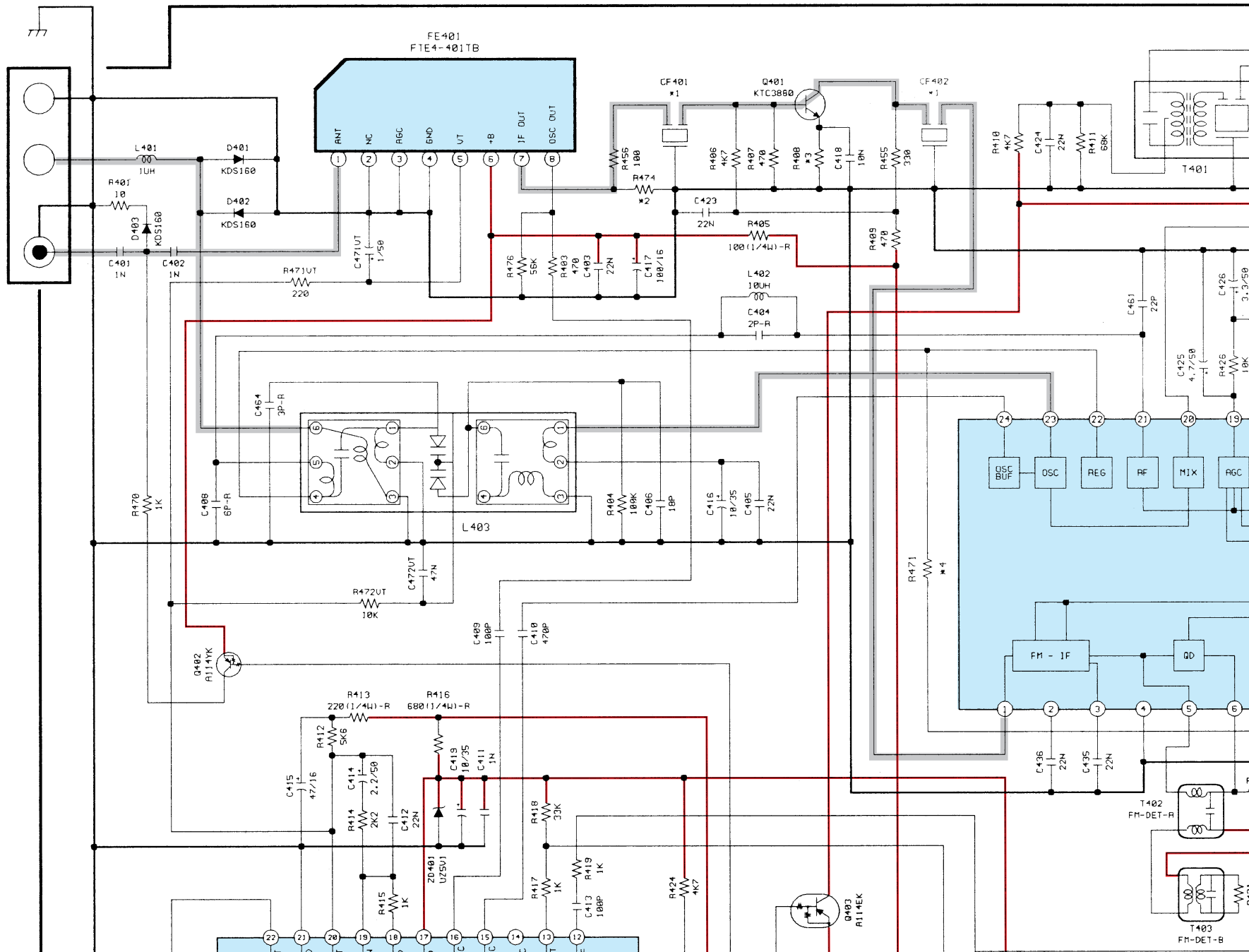

6

7

8

9

10

11

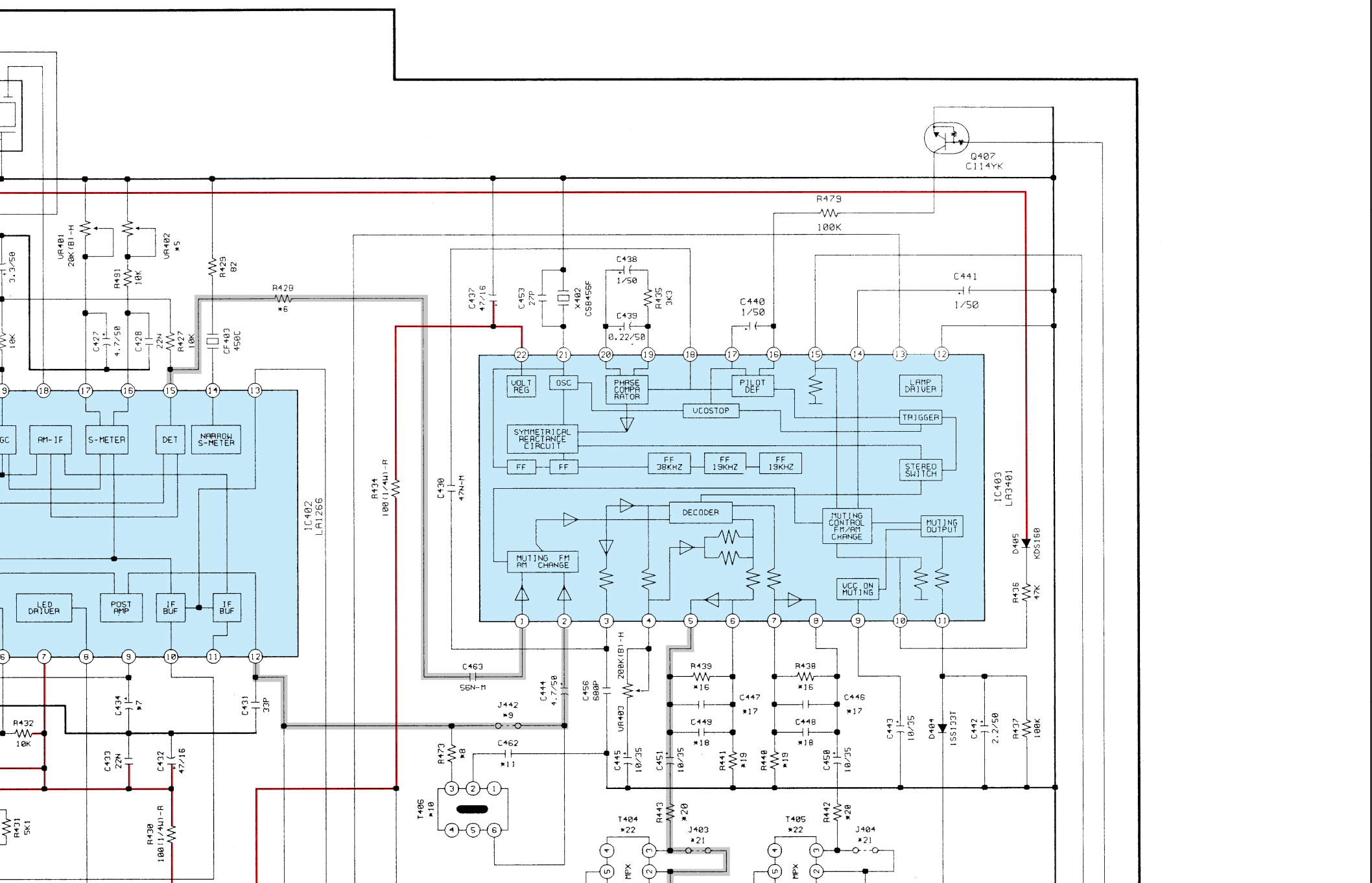

A

B

C

D

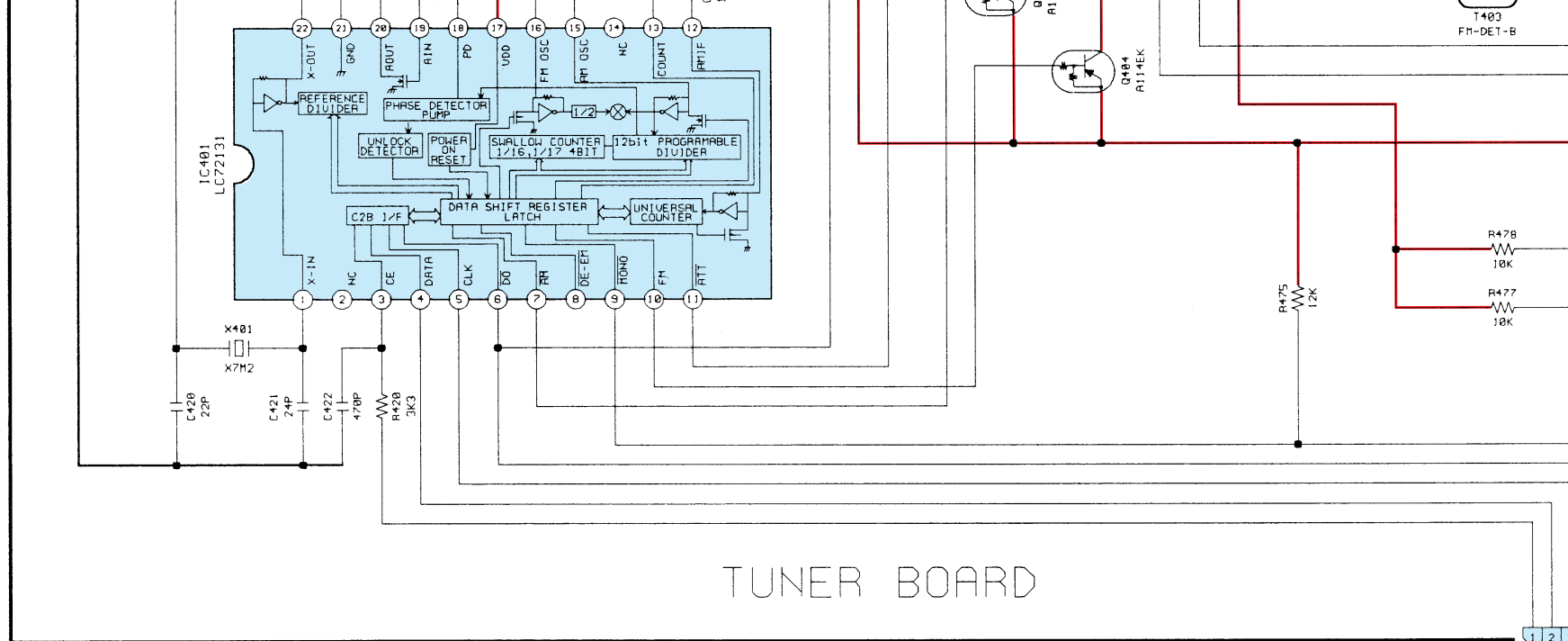

TUNER BOARD

	R-NO.	USA (E3)	EUROPE (E2)	MULTI ,CHINA
*1	CF401/CF402	SFE10.7MA8	SFE10.7MS3	10.7MA8/MS3
*2	R474	-	180	-
*3	R407/R408	470/1.2K	620/680	620/1.2K
*4	R471	18K	39K	39K
*5	UR402	50KB	100KB	50KB
*6	R428	3.3K	10K	6.8K
*7	C434	1/50	0.33/50	0.33/50
*8	R473	-	2.4K	-

	R-NO.	USA (E3)	EUROPE (E2)	MULTI ,CHINA
*9	J442	JUMPER	-	JUMPER
*10	T406	-	ANTI-BIRDIE	-
*11	C462	-	470P	-
*12	R472	-	100	-
*13	Q409	-	KTC3880	-
*14	R449	-	3.9K	-
*15	R450	-	1K	-
*16	R438 ,R439	100K	150K	100K

NOTICE

ALL RESISTANCE VALUES IN OHM. k=1,000 OHM M=1,000,000 OHM
 ALL CAPACITANCE VALUES IN MICRO FARAD. P=MICRO-MICRO FARAD
 EACH VOLTAGE AND CURRENT ARE MEASURED AT MO SIGNAL INPUT
 CONDITION.
 CIRCUIT AND PARTS ARE SUBJECT TO CHANGE WITHOUT PRIOR
 NOTICE.

WARNING:

Parts marked with this symbol  have
 Use ONLY replacement parts recommended

CAUTION:

Before returning the unit to the customer
 leakage current check or (2) a line to chassis
 current exceeds 0.5 milliamps, or if the resistance
 of the power card is less than 460kohms

WARNING:

DO NOT return the unit to the customer
 corrected.

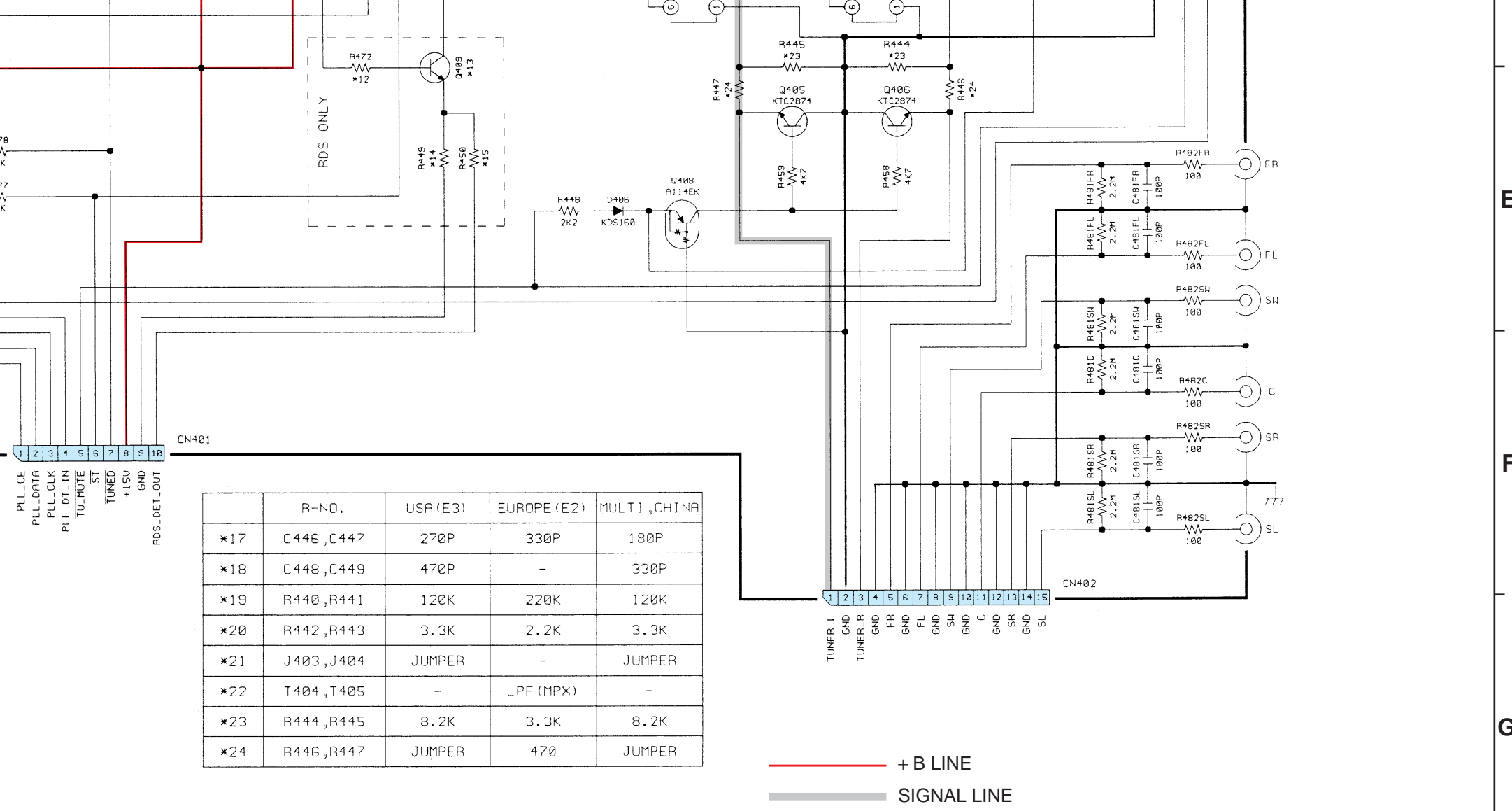

have critical characteristics.
 recommended by the manufacture.

customer, make sure you make either (1) a
 e to chassis resistance check. If the leakage
 if the resistance from chassis to either side
 0kohms, the unit is defective.

customer until the problem is located and

SCHEMATIC DIAGRAMS(7/7) TUNER P.W.B. UNIT

E
 F
 G
 H