

— GND — POWER + — POWER - - - - - STBY POWER

FROM DIGITAL CONNECT (PAGE 15/30)

TO ETHERNET PHY (PAGE 26/30)

3 SCHEMATIC DIAGRAMS (1/30)
USB UNIT
FRONT UNIT

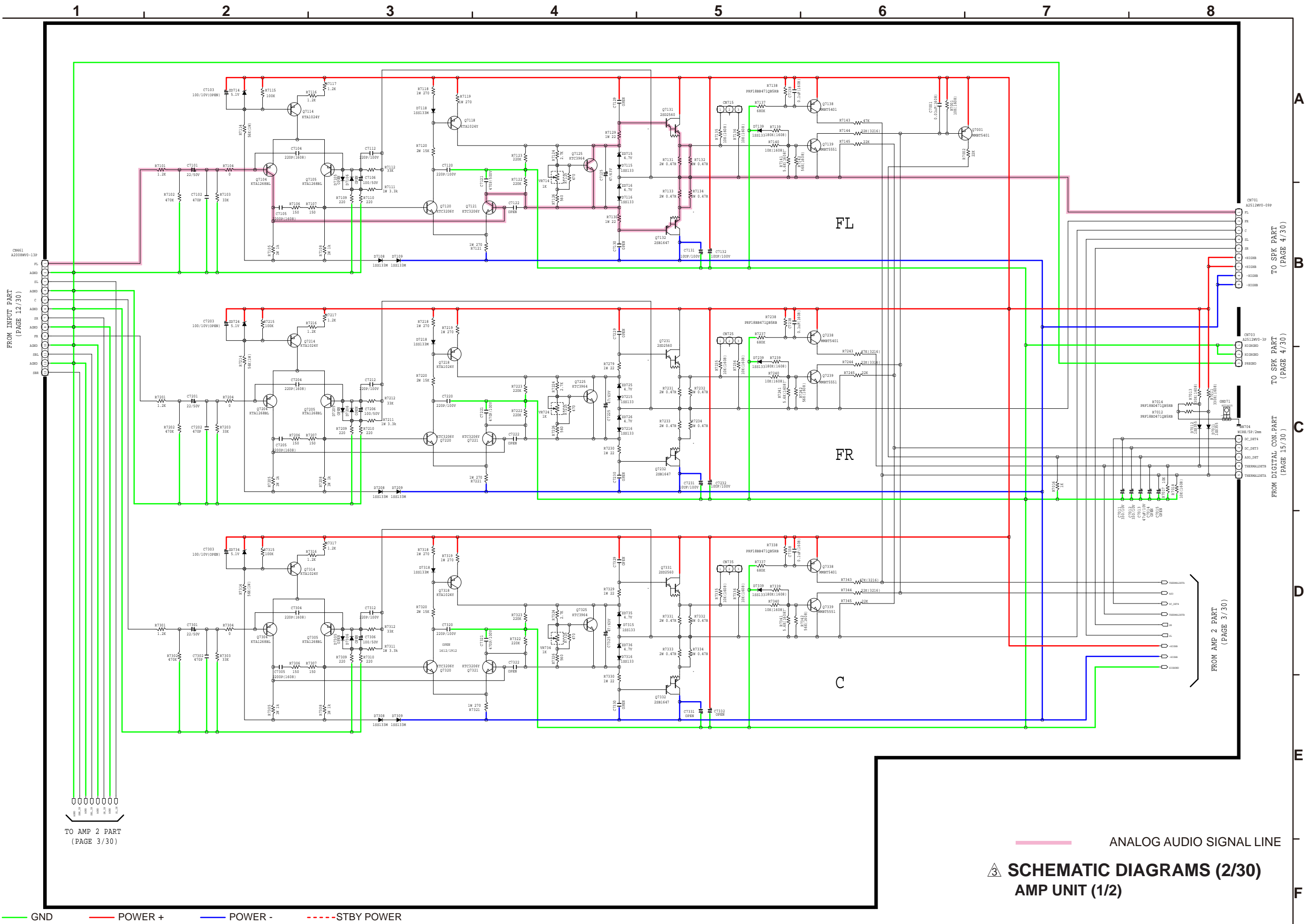

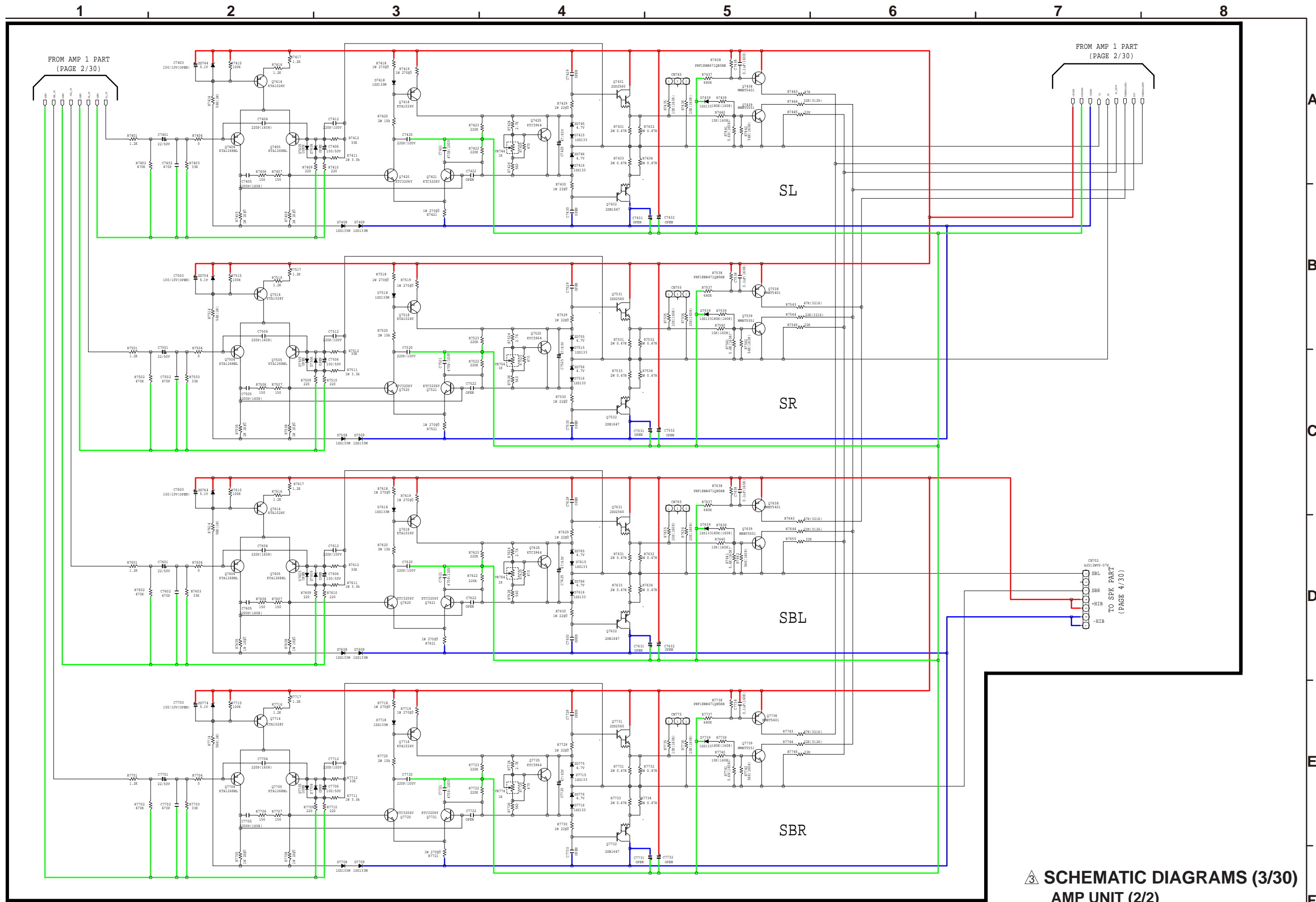

— GND — POWER + — POWER - - - - STBY POWER

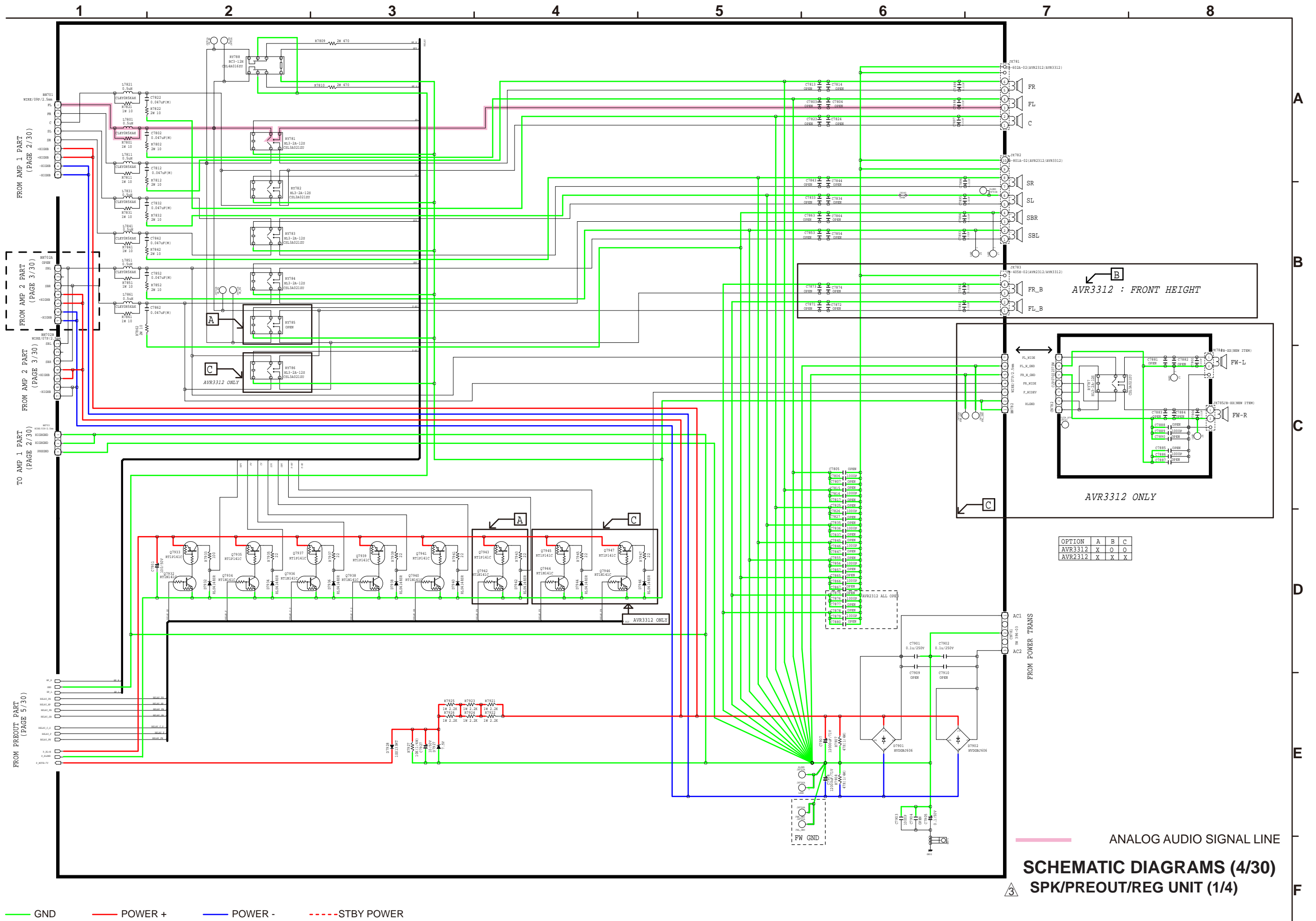

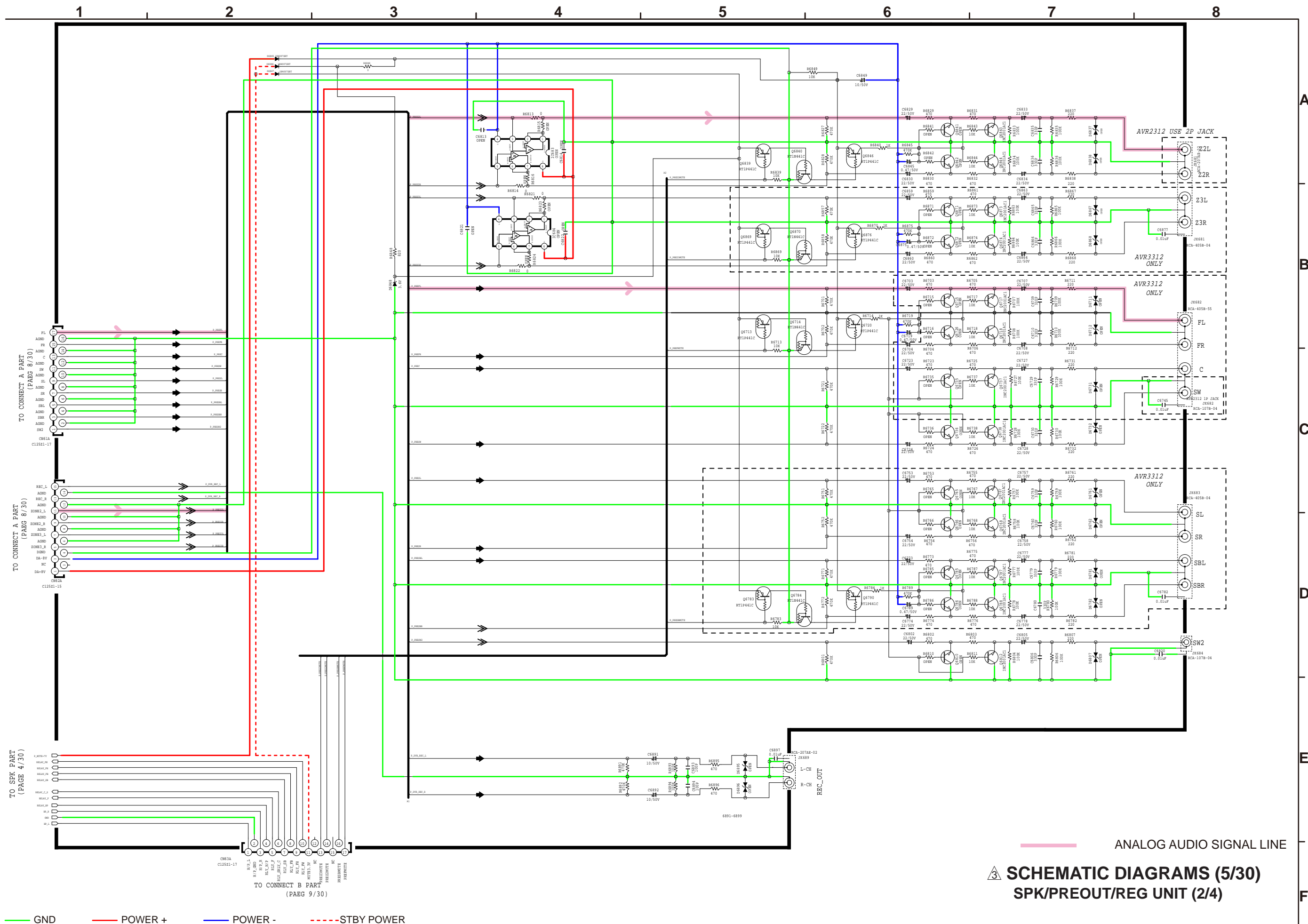

TO CONNECT A PART
(PAGE 8/30)

TO CONNECT A PART
(PAGE 8/30)

TO SEK PART
(PAGE 4/30)

TO CONNECT B PART
(PAGE 9/30)

ANALOG AUDIO SIGNAL LINE

SCHEMATIC DIAGRAMS (5/30)
SPK/PREOUT/REG UNIT (2/4)

— GND — POWER + — POWER - - - - STBY POWER

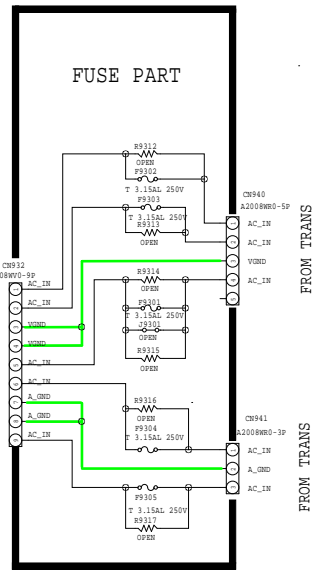
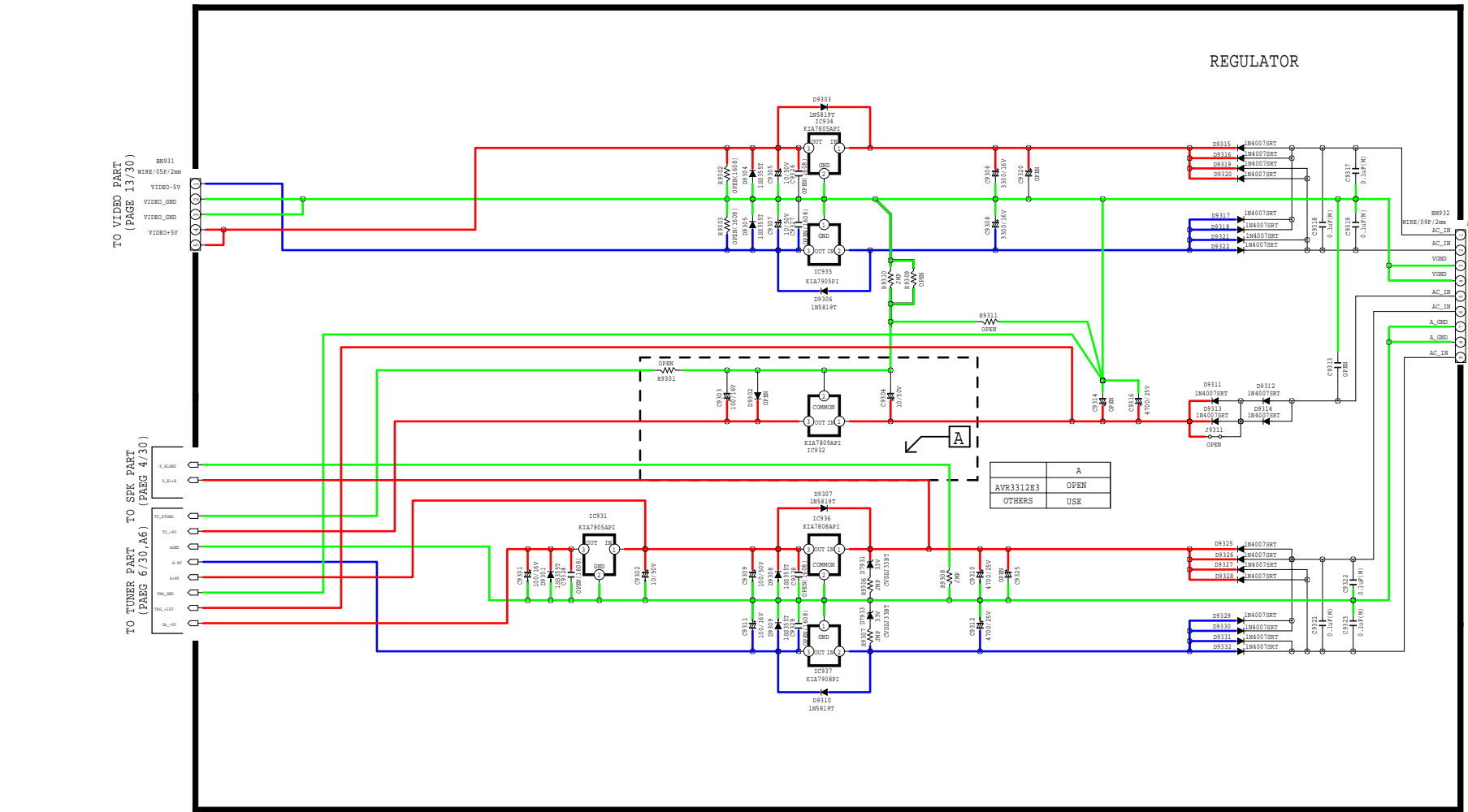
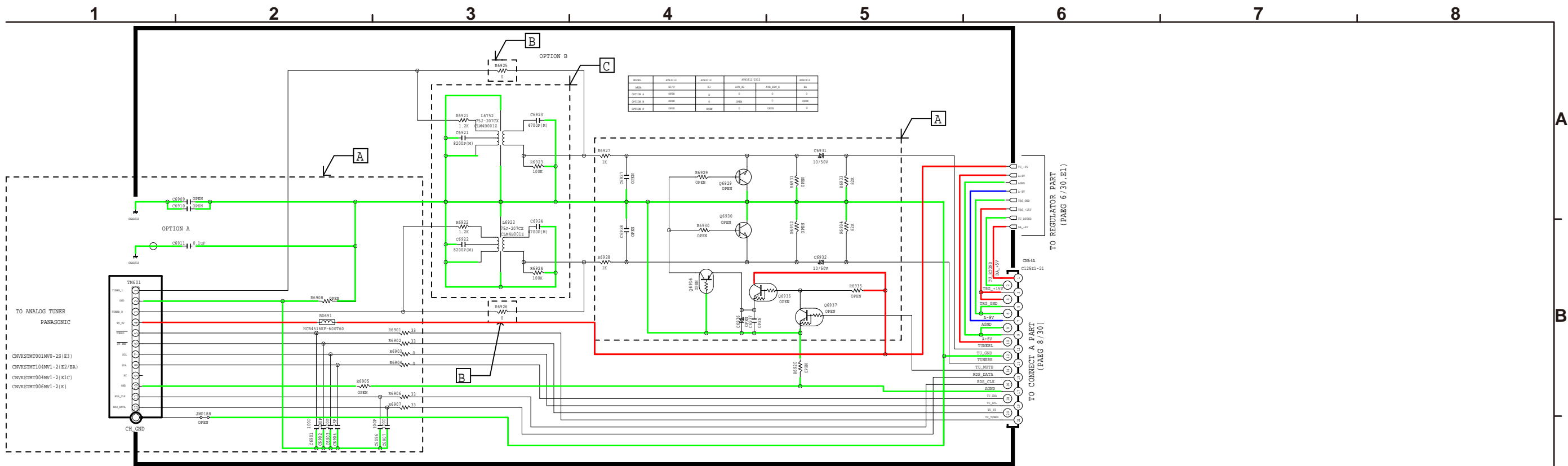

— GND
 — POWER +
 — POWER -
 - - - STBY POWER

3 SCHEMATIC DIAGRAMS (6/30)
SPK/PREOUT/REG UNIT (3/4)

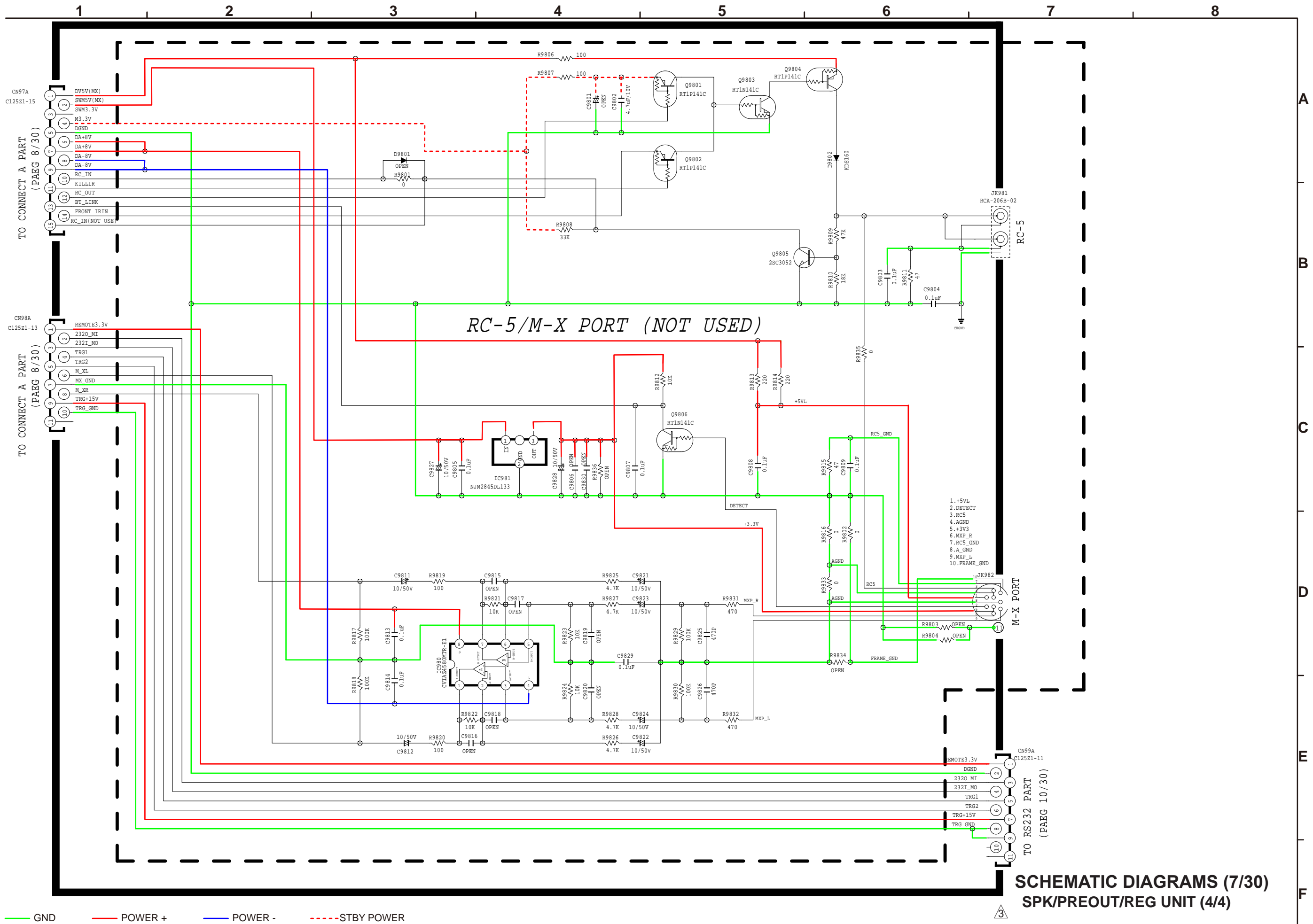

SCHEMATIC DIAGRAMS (7/30)
SPK/PREOUT/REG UNIT (4/4)

SIDE CNT_CUP12387Z

OPTION	E3	OTHERS
AVR3312	HD TUNER	ANALOG TUNER
AVR2312	ANALOG TUNER	ANALOG TUNER

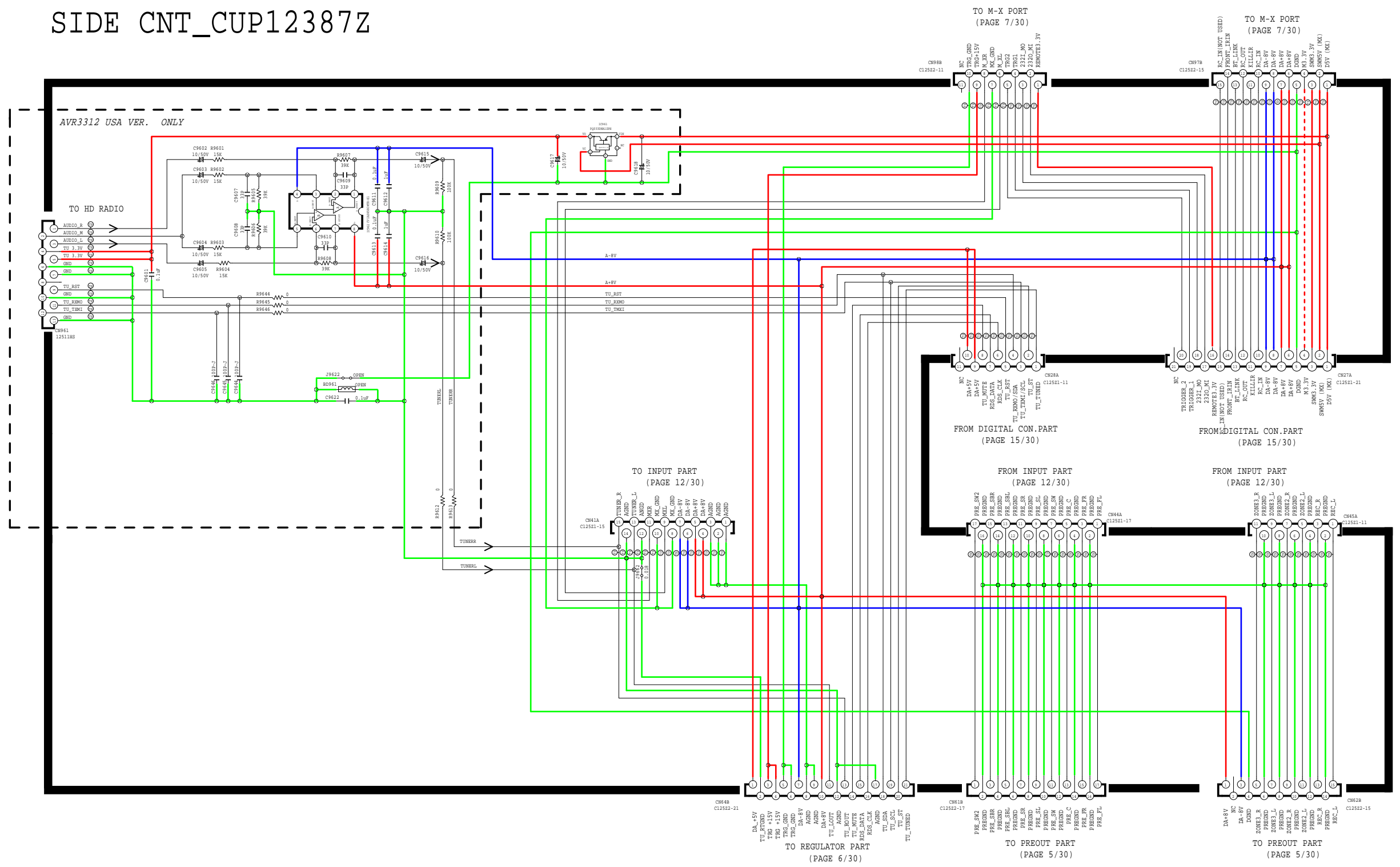

3 SCHEMATIC DIAGRAMS (8/30)
CNT/RS232C UNIT (1/4)

— GND — POWER + — POWER - - - - STBY POWER

FRT CNT_CUP12387Z

FROM/TO DIGITAL CON. PART
(PAGE 15/30)

OPTION TABLE

	CN606	
	NM	MOUNT
R9701	0R	OPEN
R9702	0R	OPEN
R9711	OPEN	0R
R9712	OPEN	0R

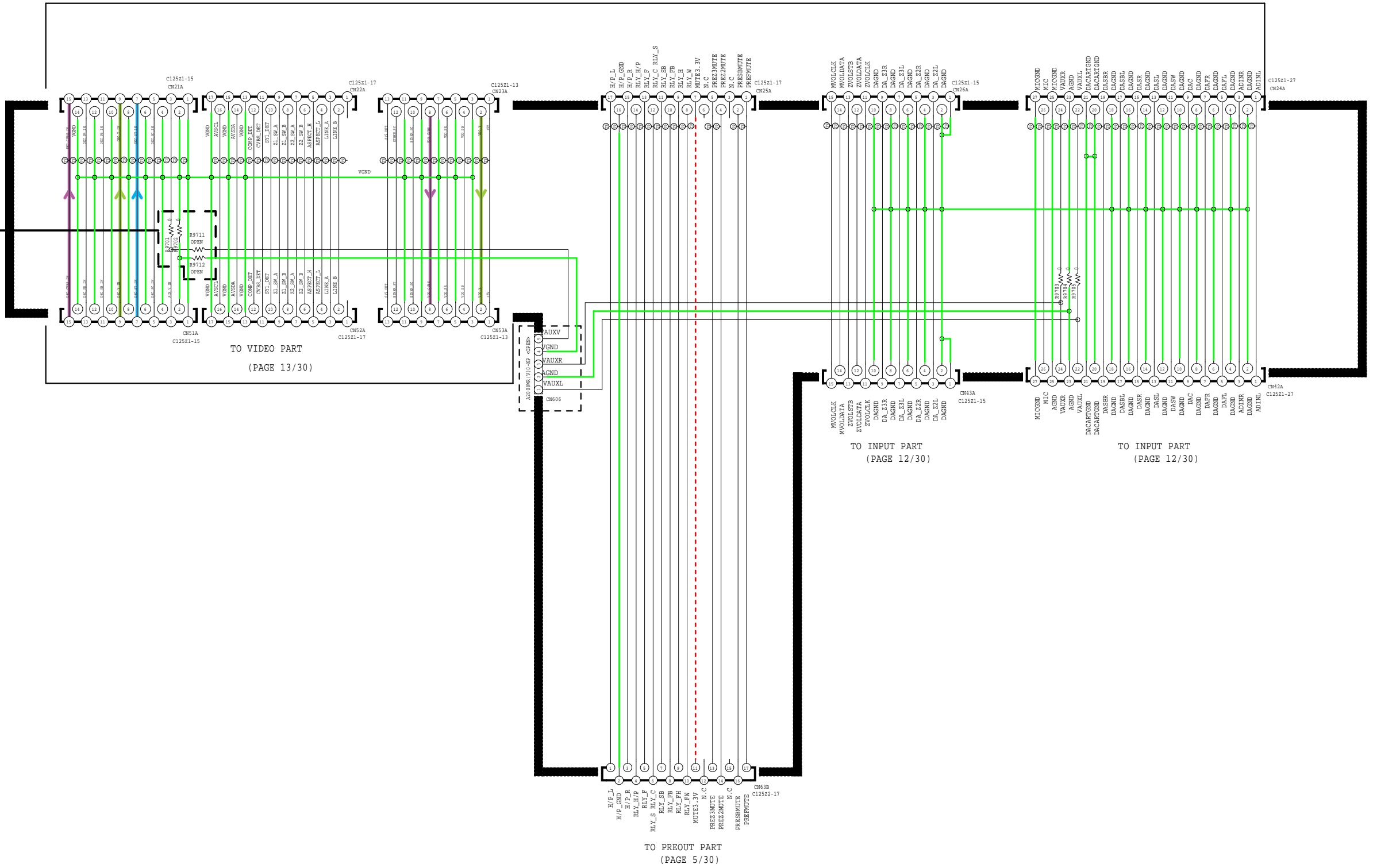

— GND — POWER + — POWER - - - - STBY POWER

— VIDEO SIGNAL LINE
— S(Y) VIDEO SIGNAL LINE
— COMPONENT (Y) SIGNAL LINE

3 SCHEMATIC DIAGRAMS (9/30)
CNT/RS232C UNIT (2/4)

RS232-TRIGGER_CUP12387Z

RS232C/TRIGGER

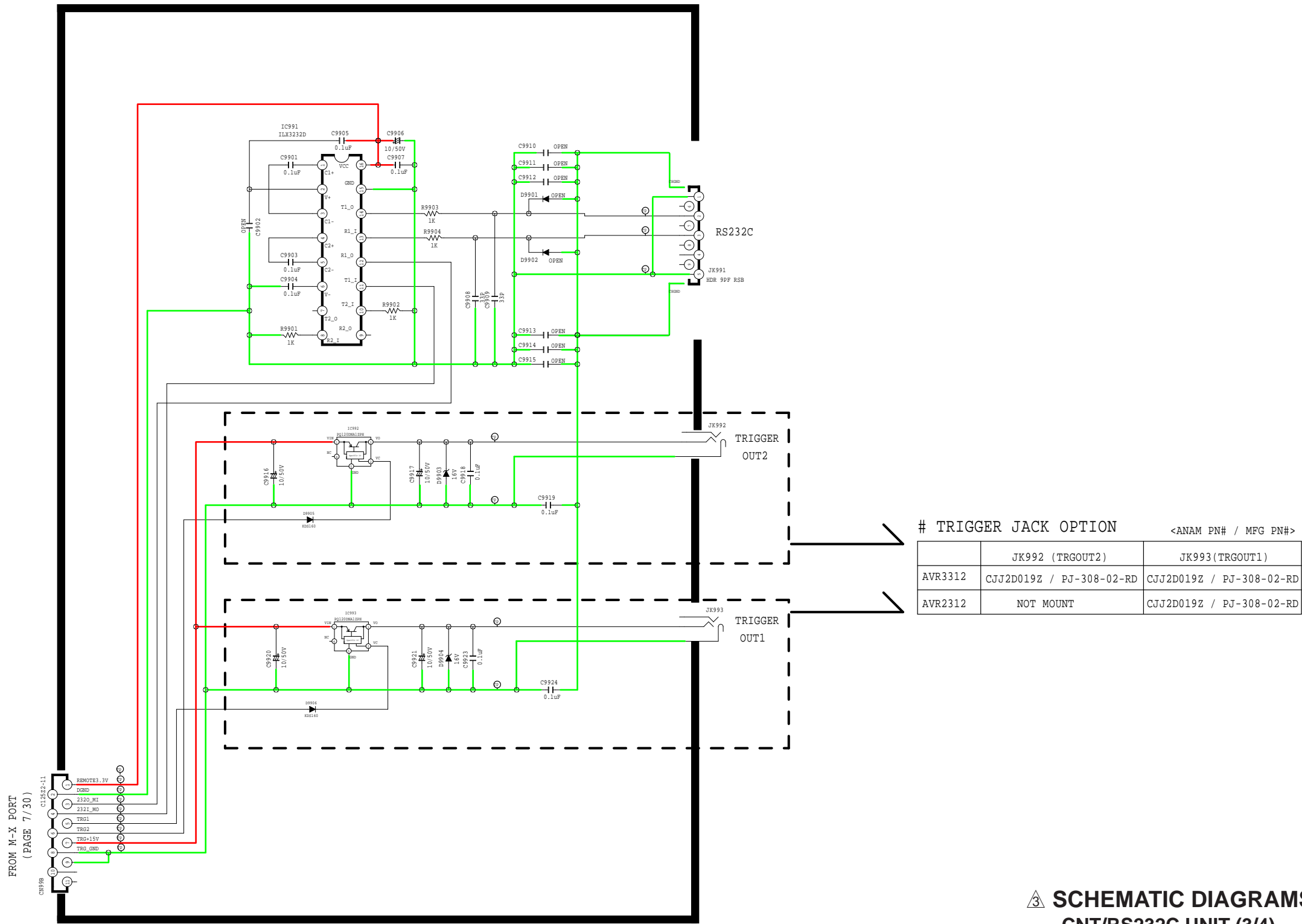

— GND
 — POWER +
 — POWER -
 — STBY POWER

⚠ SCHEMATIC DIAGRAMS (10/30)
 CNT/RS232C UNIT (3/4)

D-TERMINAL_CUP12387Z

D-TERMINAL

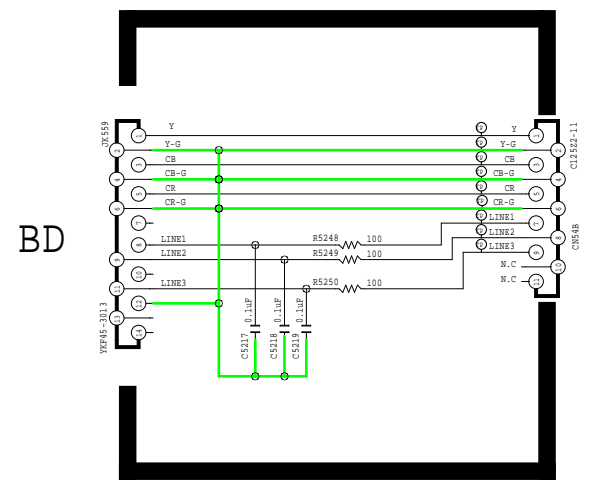

FROM VIDEO PART
(PAGE 13/30)

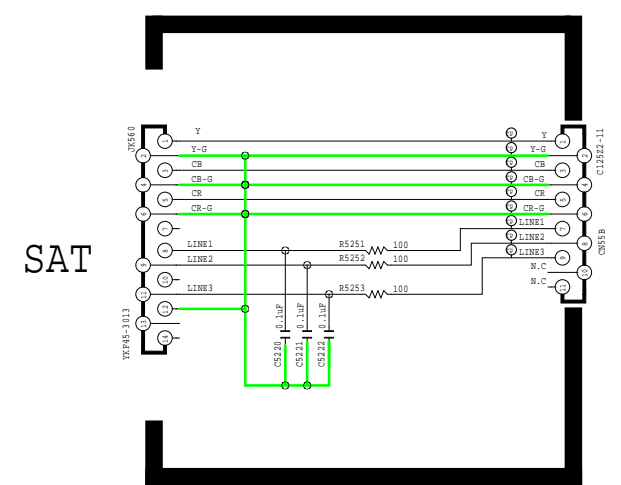

FROM VIDEO PART
(PAGE 13/30)

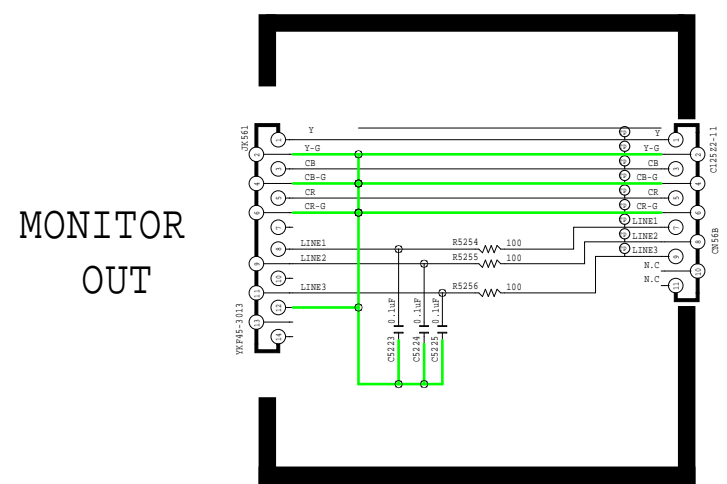

FROM VIDEO PART
(PAGE 13/30)

— GND — POWER + — POWER - - - - STBY POWER

⚠ SCHEMATIC DIAGRAMS (11/30)
CNT/RS232C UNIT (4/4)

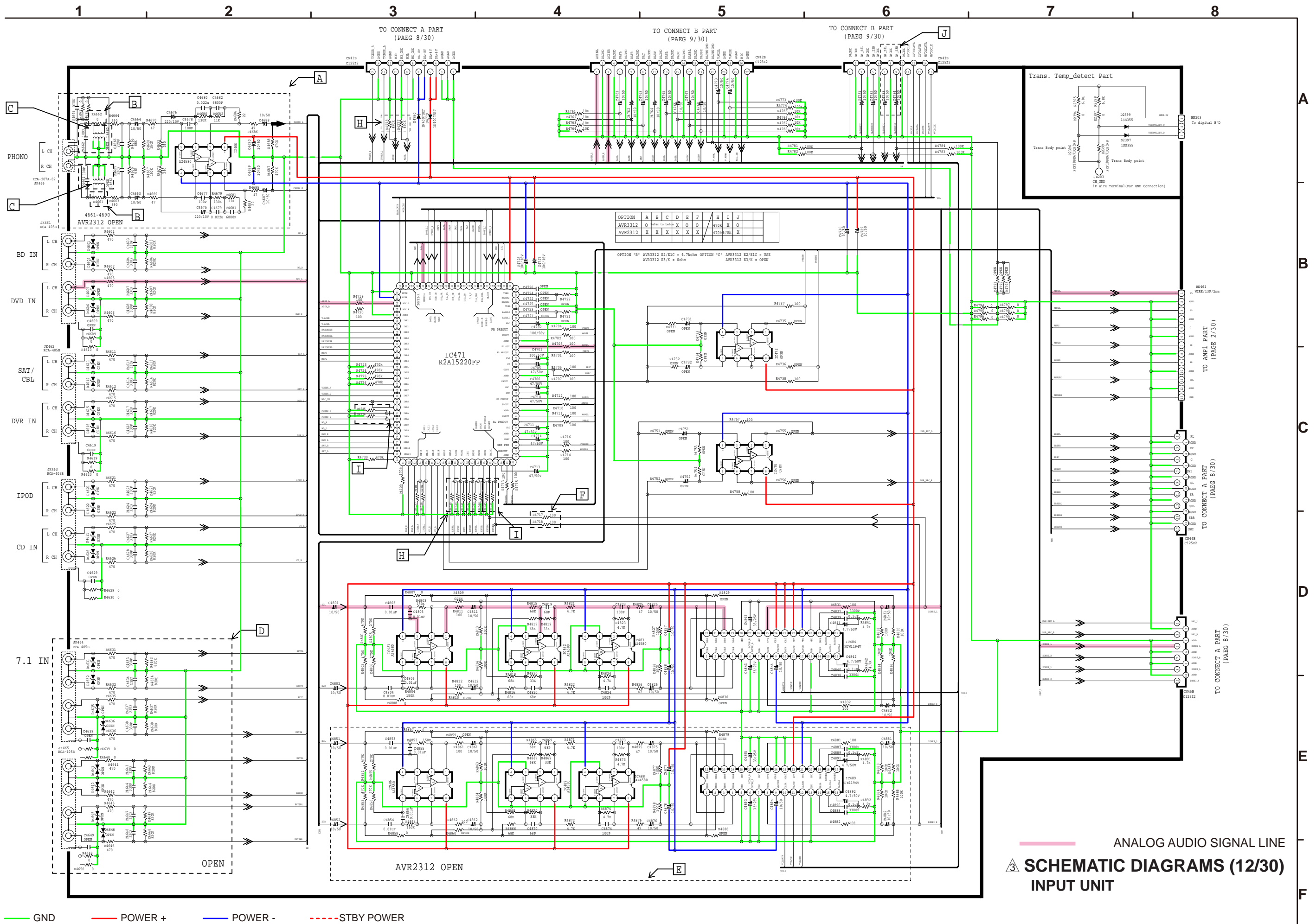

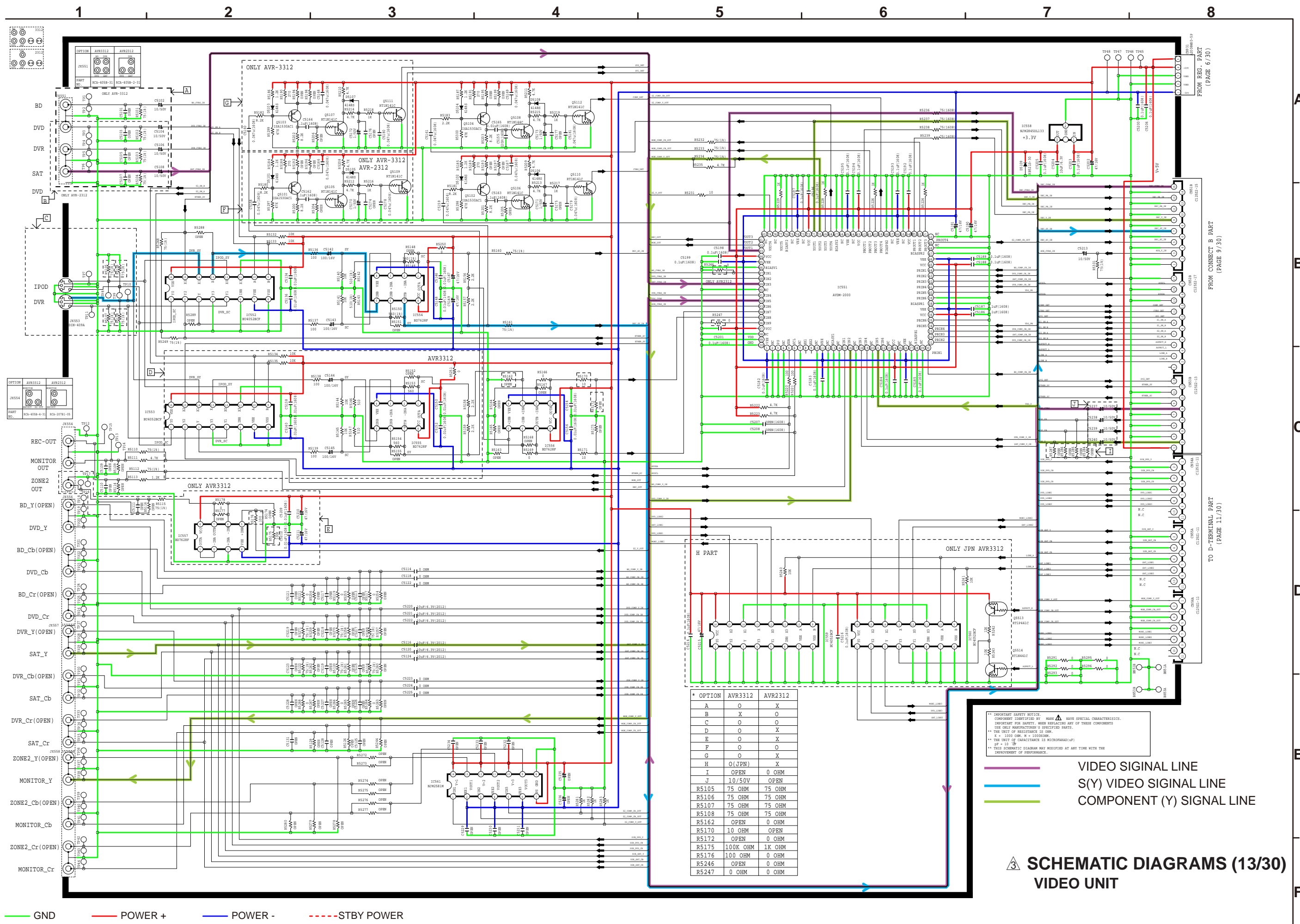

SMPS B'D

**** IMPORTANT SAFETY NOTICE.**
 COMPONENT IDENTIFIED BY MAY HAVE SPECIAL CHARACTERISTICS.
 IMPORTANT FOR SAFETY, WHEN REPLACING ANY OF THESE COMPONENTS
 USE ONLY MANUFACTURER'S SPECIFIED PARTS.
 ** THE UNIT OF RESISTANCE IS OHM.
 * K = 1000 OHM * M = 10000OHM.
 ** THE UNIT OF CAPACITANCE IS MICROFARAD(UF)
 pF = 10⁻¹²
 ** THIS SCHEMATIC DIAGRAM MAY MODIFIED AT ANY TIME WITH THE
 IMPROVEMENT OF PERFORMANCE.

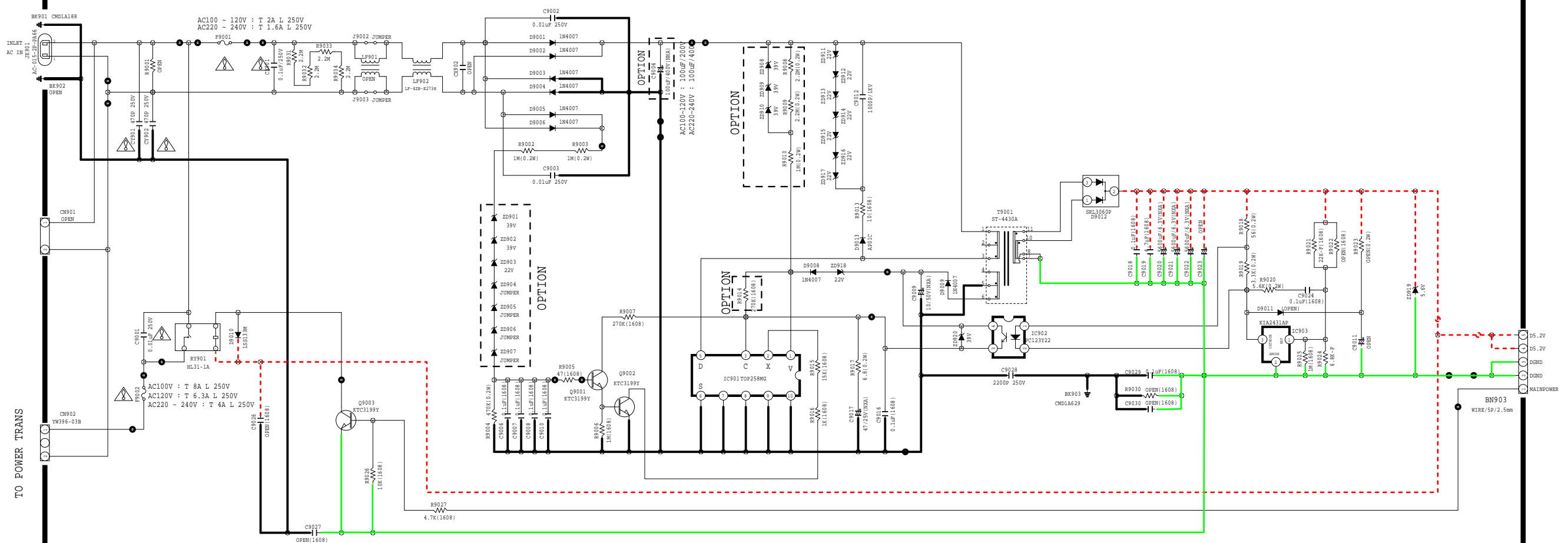

OPTION

	ZD901	ZD902	ZD903	ZD904	ZD905	ZD906	ZD907	ZD908	ZD909	ZD910	R9008	R9009	R9010	R9014
120V	ZJ39B	ZJ39B	ZJ22B	JUMPER	JUMPER	JUMPER	JUMPER	ZJ39B	ZJ39B	ZJ39B	2M2(0.2W)	2M2(0.2W)	1M(0.2W)	270K
220~230V	1M(0.2W)	1M(0.2W)	ZJ39B	ZJ39B	ZJ39B	ZJ39B	ZJ39B	OPEN	OPEN	OPEN	OPEN	OPEN	OPEN	56K
100V	ZJ39B	ZJ39B	JUMPER	JUMPER	JUMPER	JUMPER	JUMPER	ZJ39B	ZJ39B	ZJ39B	2M2(0.2W)	2M2(0.2W)	1M(0.2W)	270K

TO DIGITAL SUPPLY_POWER
(PAGE 16/30)

SCHEMATIC DIAGRAMS (14/30) SMPS UNIT

— GND — POWER + — POWER - - - - STBY POWER

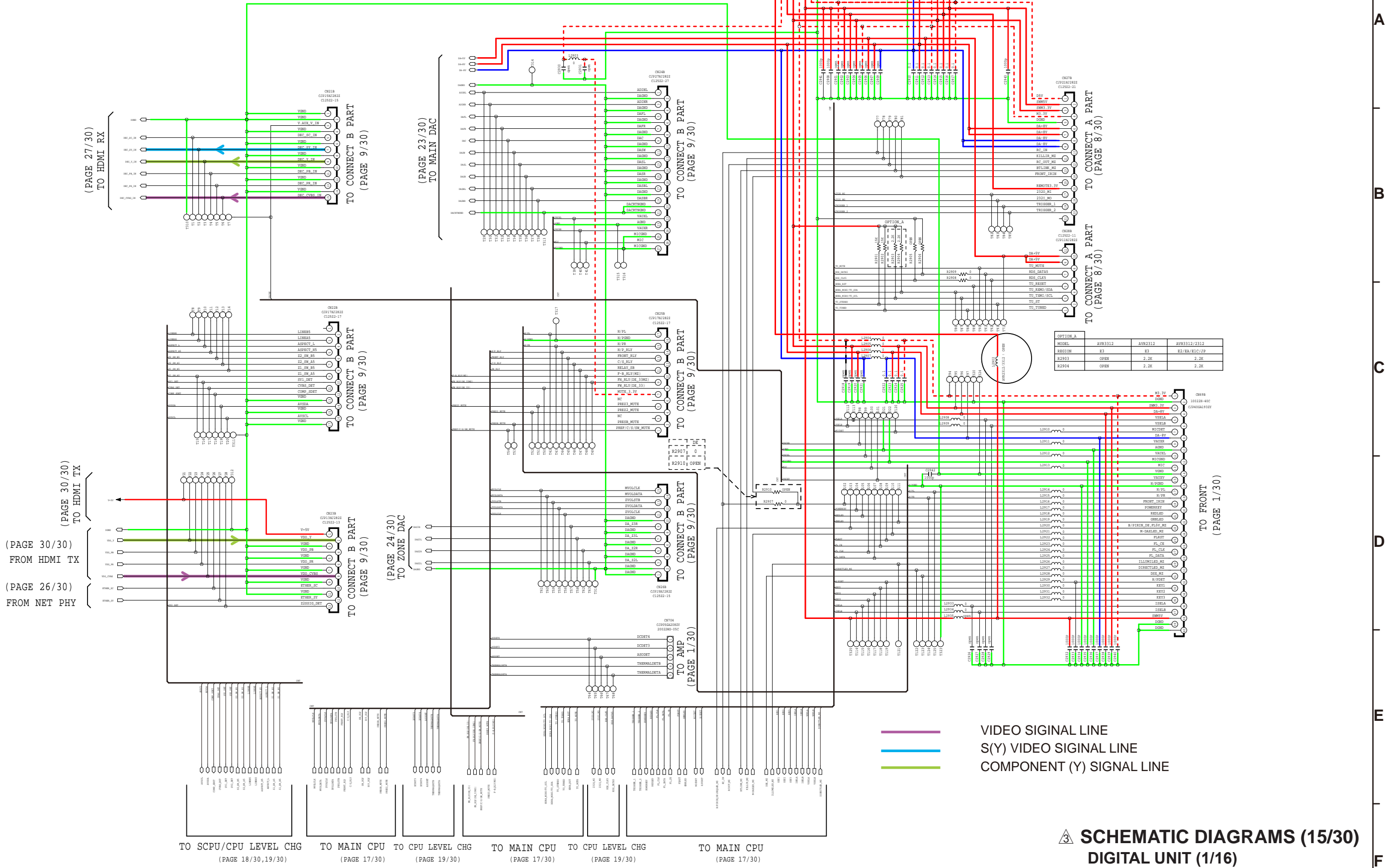

SCHEMATIC DIAGRAMS (15/30)
DIGITAL UNIT (1/16)

GND POWER + POWER - STBY POWER

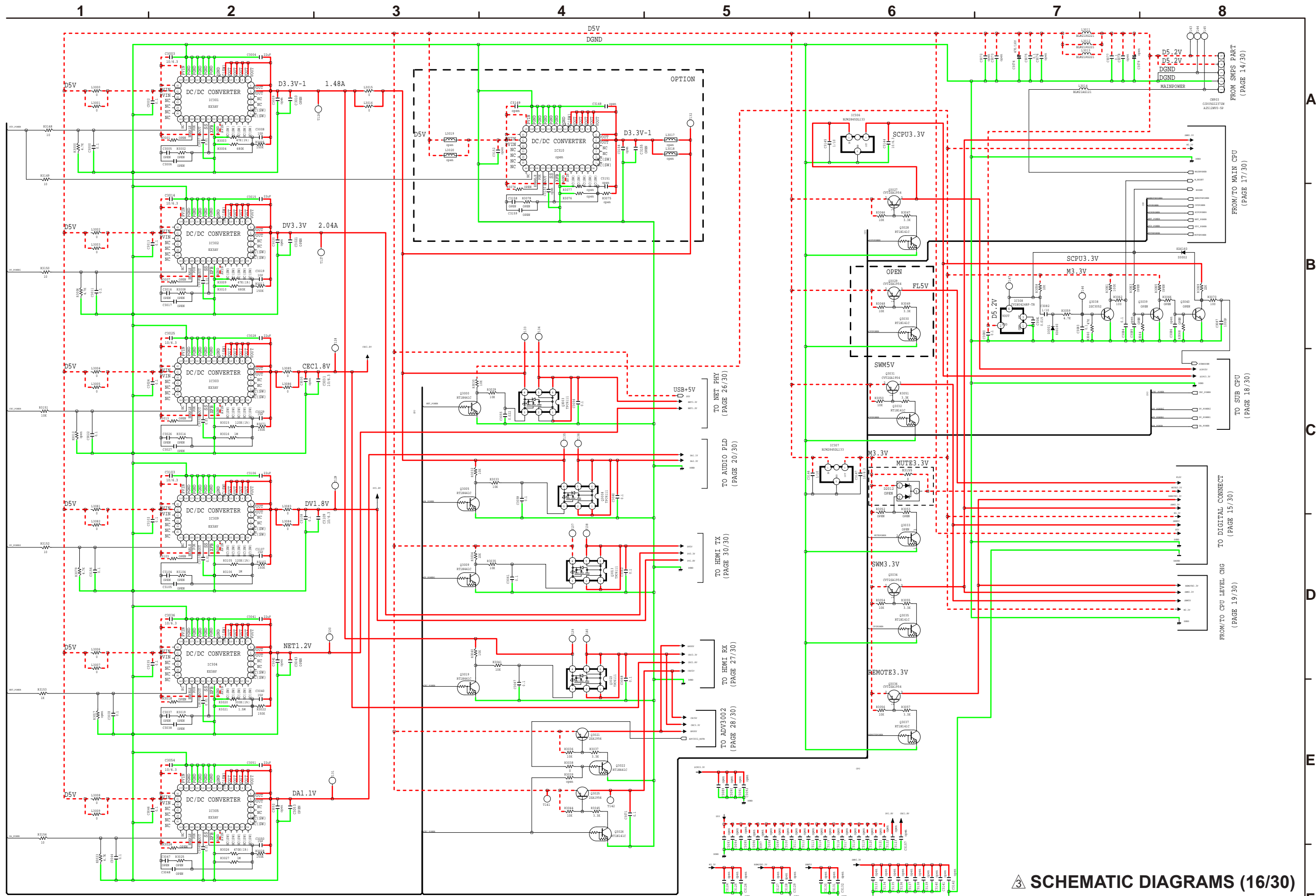

⚠ SCHEMATIC DIAGRAMS (16/30)
DIGITAL UNIT (2/16)

— GND — POWER + — POWER - - - - STBY POWER

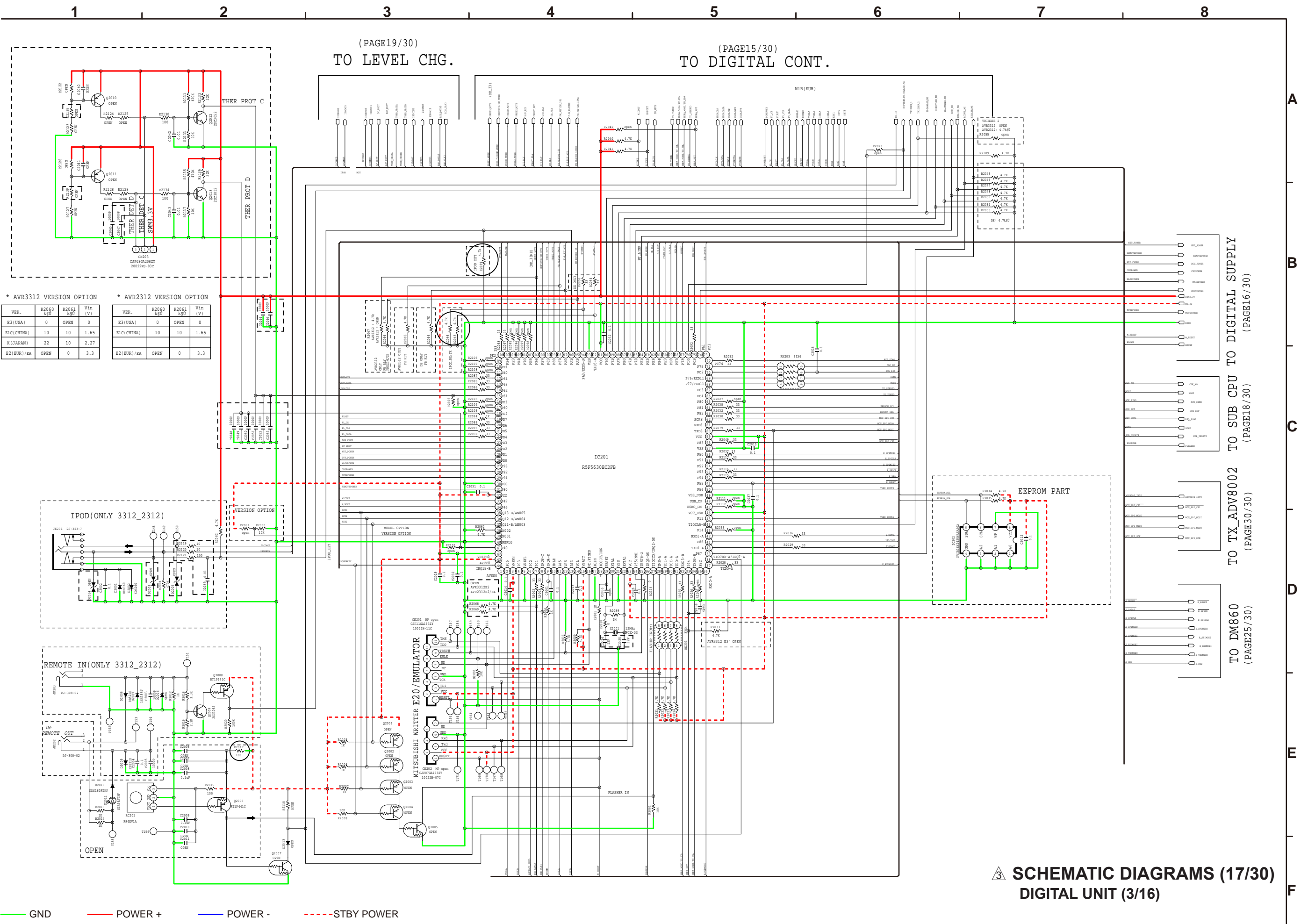

SCHEMATIC DIAGRAMS (17/30)
DIGITAL UNIT (3/16)

— GND — POWER + — POWER - - - - STBY POWER

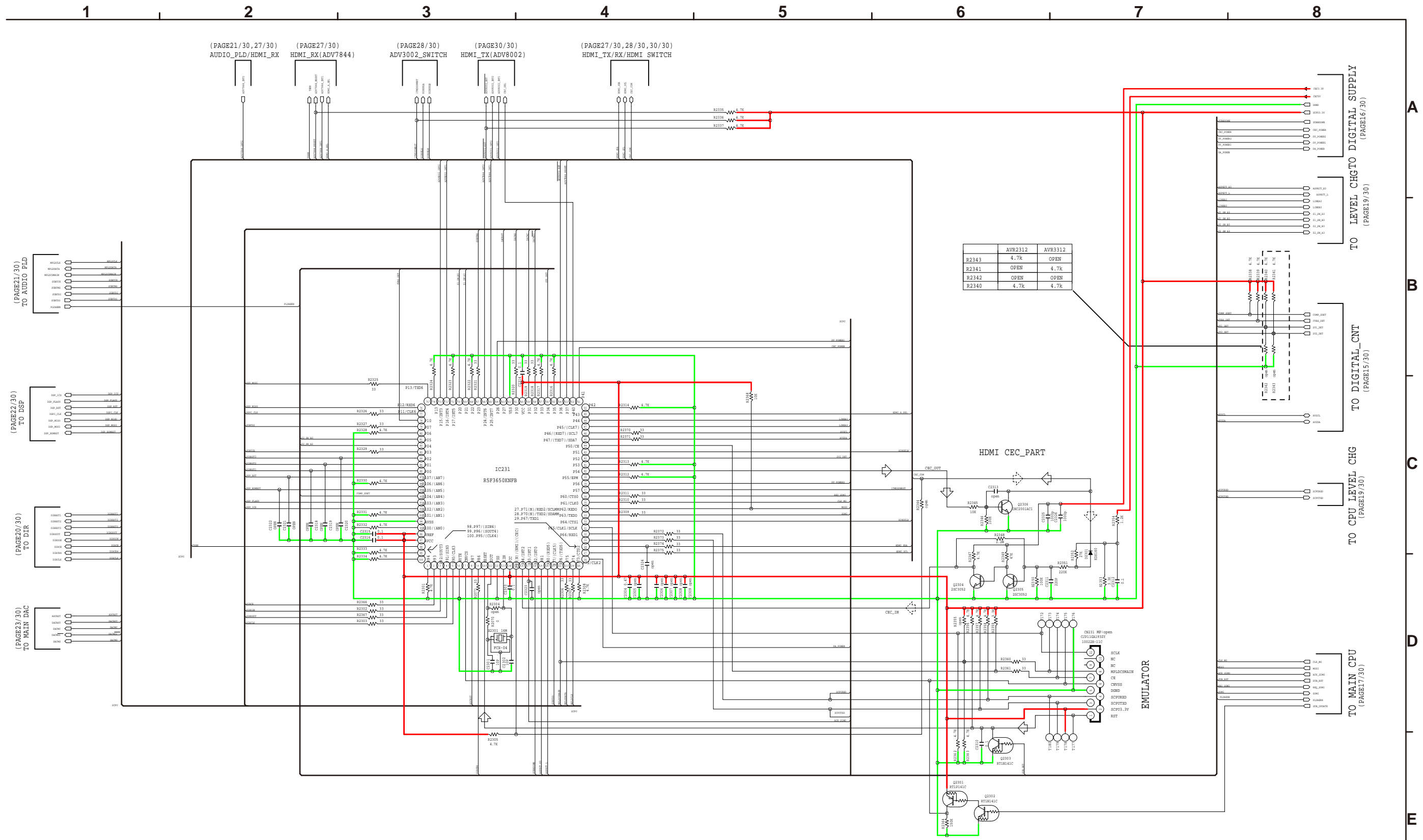

3 SCHEMATIC DIAGRAMS (18/30)
DIGITAL UNIT (4/16)

— GND — POWER + — POWER - - - - STBY POWER

— GND — POWER + — POWER - - - - STBY POWER

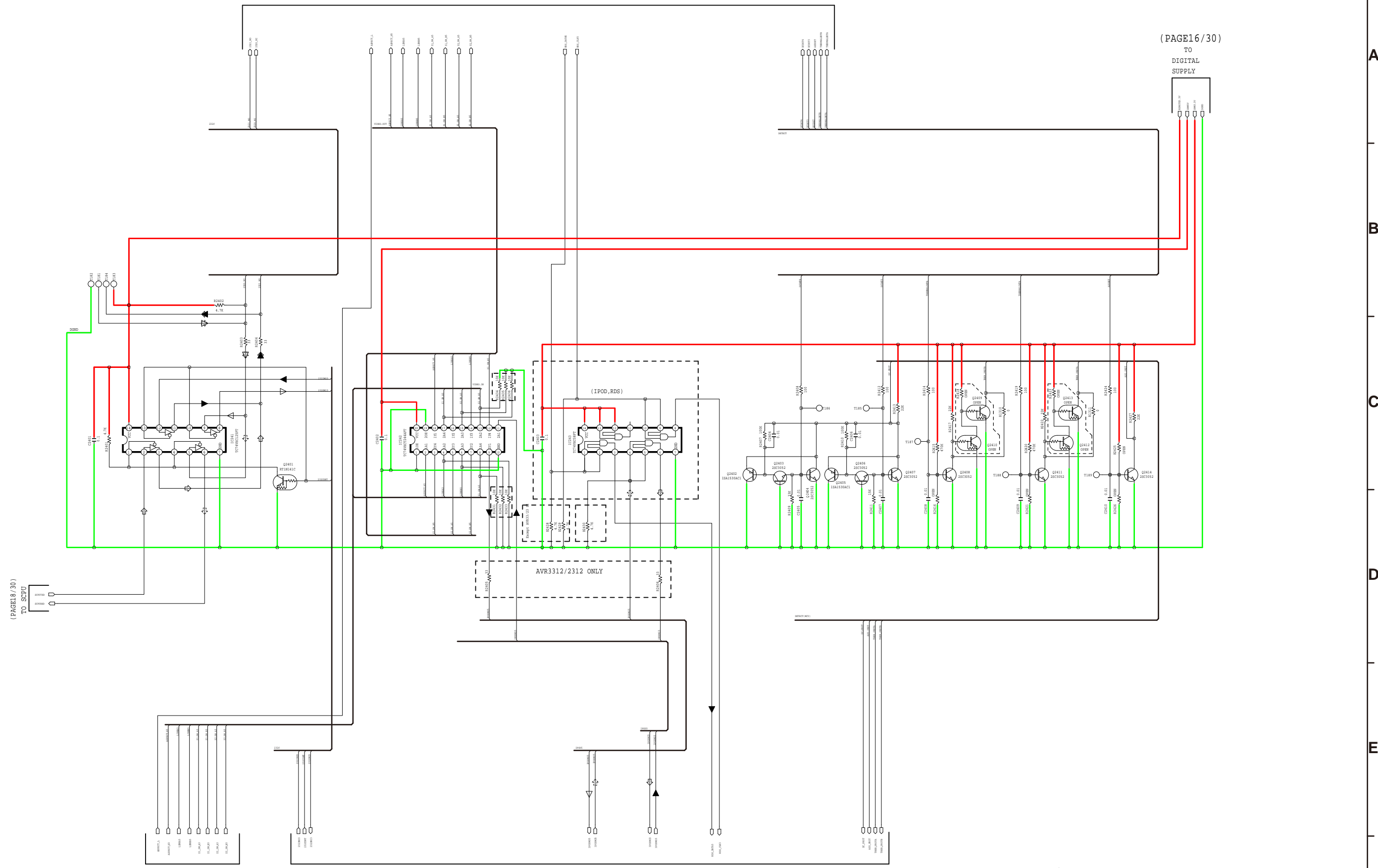

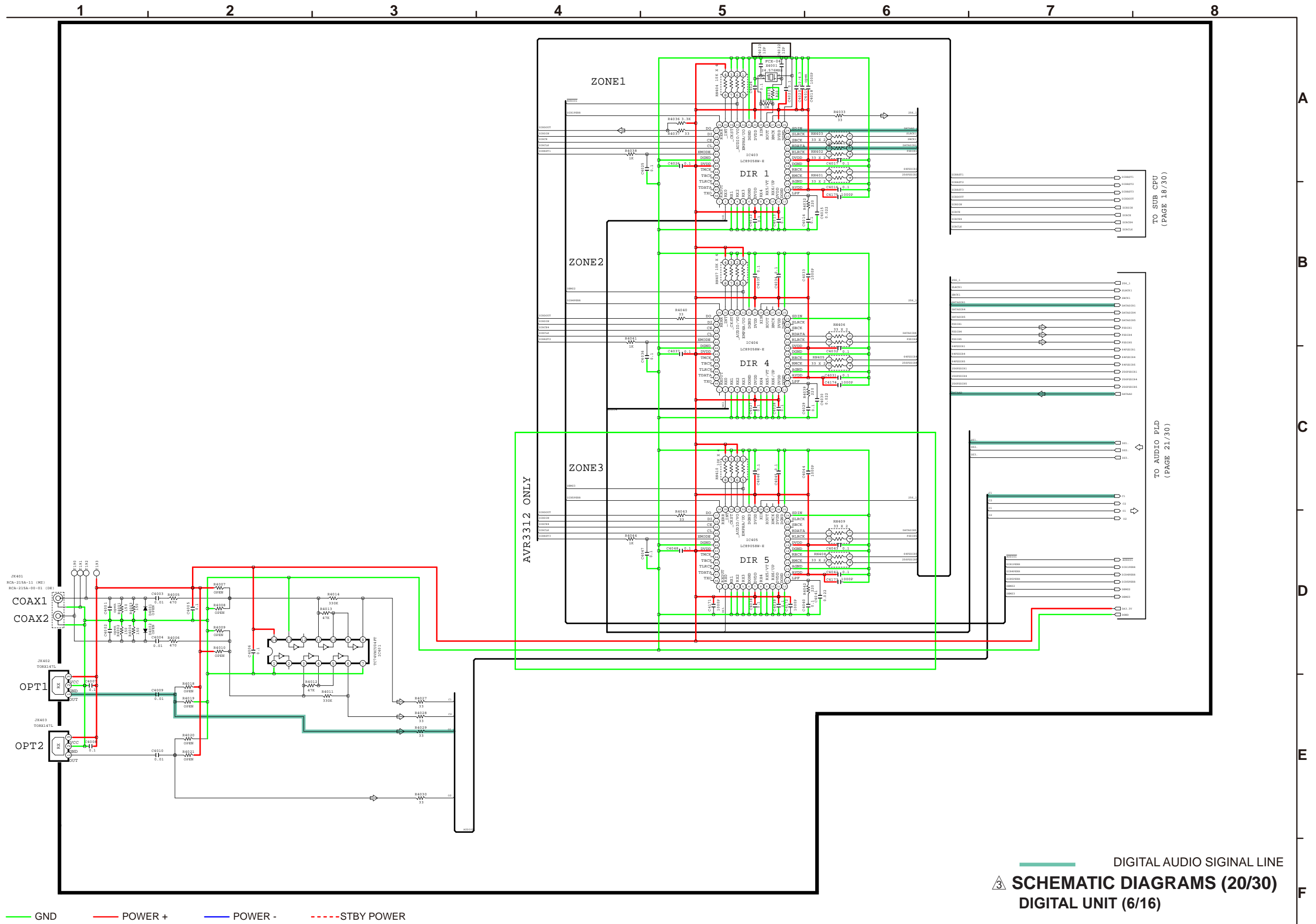

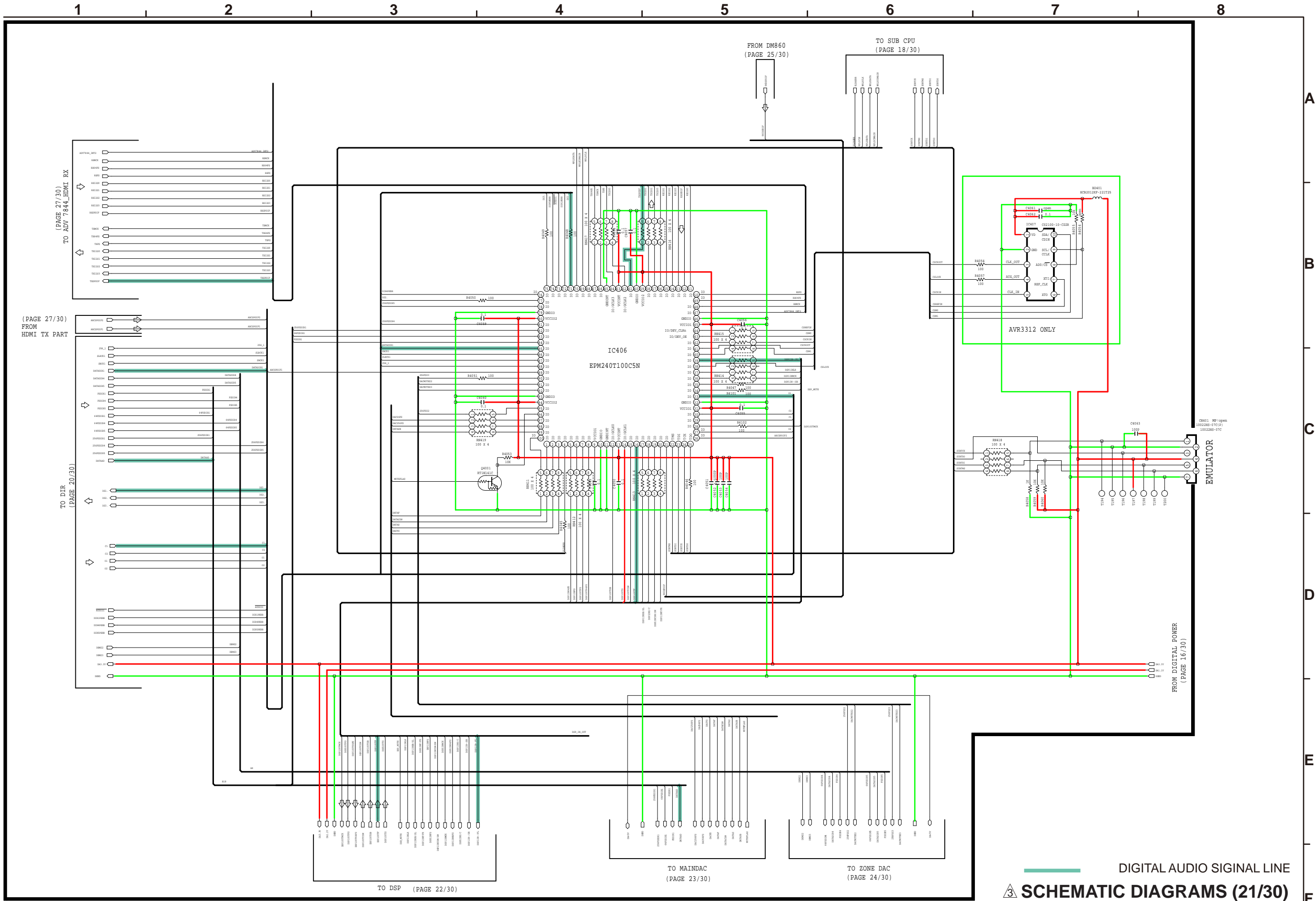

— GND
 — POWER +
 — POWER -
 — STBY POWER

— DIGITAL AUDIO SIGNAL LINE
3 SCHEMATIC DIAGRAMS (21/30)
DIGITAL UNIT (7/16)

(PAGE 21/30)
FROM PLD PART

(PAGE 21/30)
FROM PLD PART

(PAGE 21/30)
TO PLD PART

(PAGE 18/30)
FROM SCPU PART

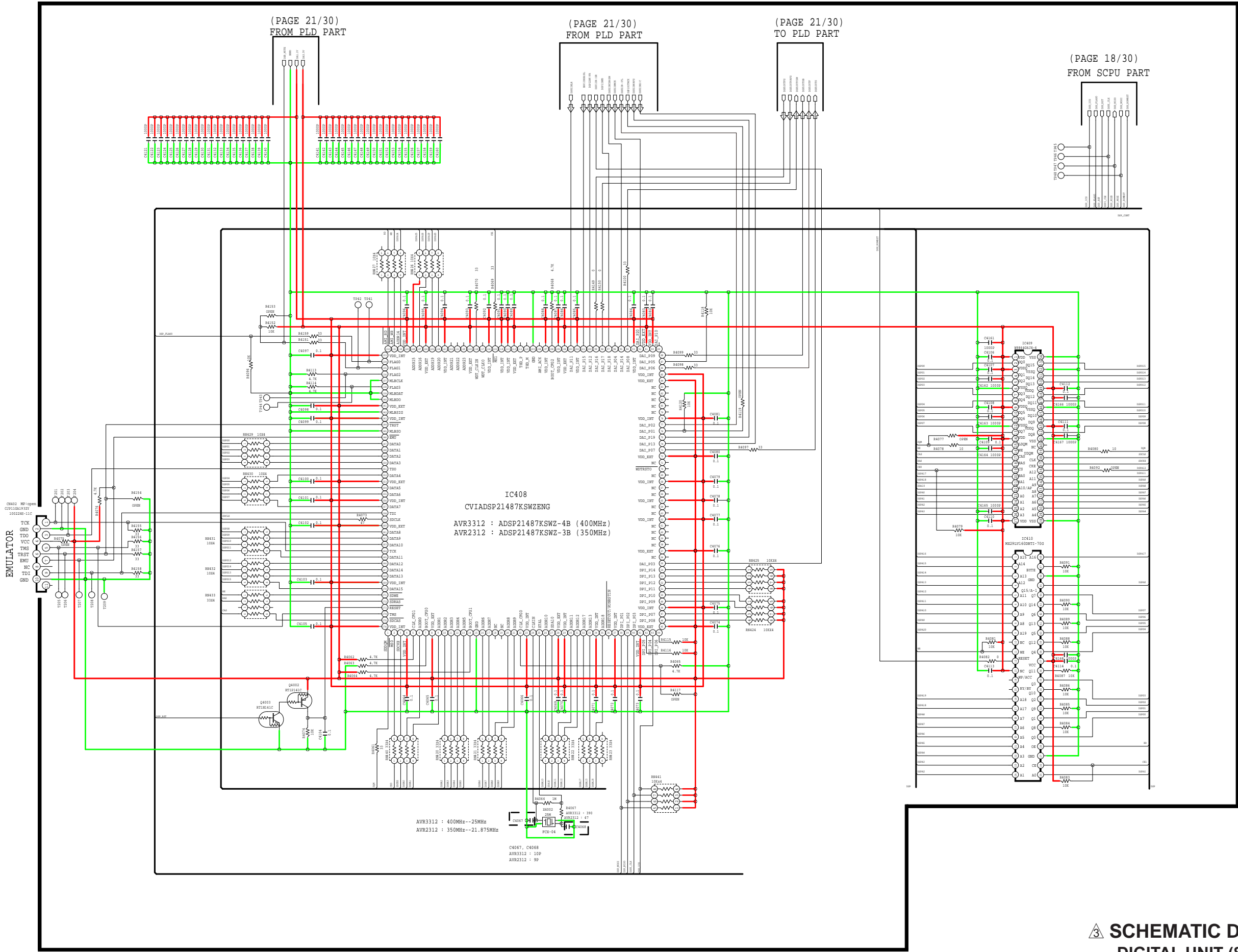

IC408
CVIADSP21487KSWZENG
AVR3312 : ADSP21487KSWZ-4B (400MHz)
AVR2312 : ADSP21487KSWZ-3B (350MHz)

AVR3312 : 400MHz--25MHz
AVR2312 : 350MHz--21.875MHz

C4007, C4008
AVR3312 : 10P
AVR2312 : 5P

⚠ SCHEMATIC DIAGRAMS (22/30)
DIGITAL UNIT (8/16)

— GND — POWER + — POWER - - - - STBY POWER

(PAGE 21/30)
TO AUDIO PLD

(PAGE 18/30)
TO SUB CPU

TO DIGITAL CONNECT
(PAGE 15/30)

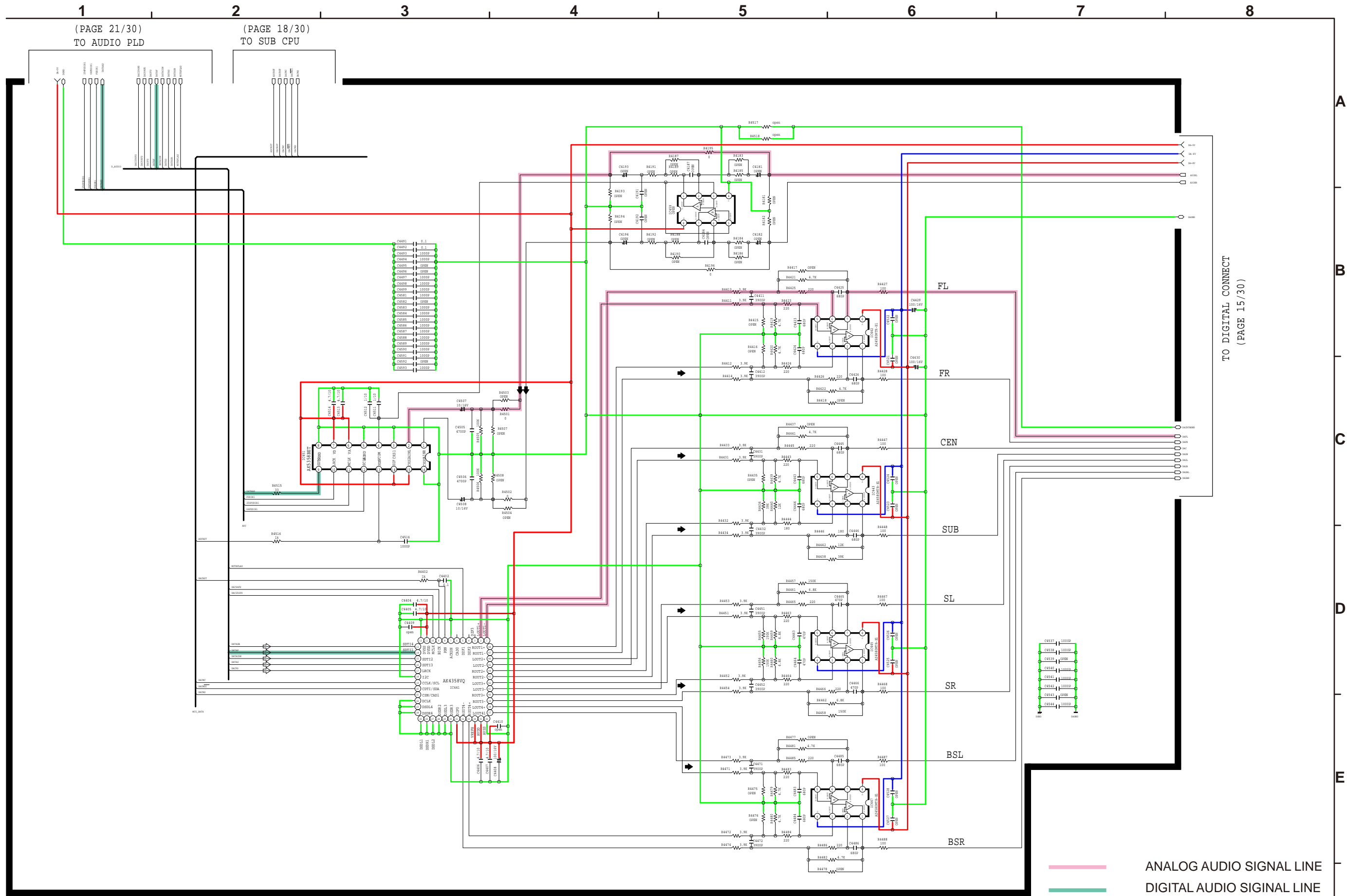

— GND
 — POWER +
 — POWER -
 — STBY POWER

— ANALOG AUDIO SIGNAL LINE
— DIGITAL AUDIO SIGNAL LINE

⚠ **SCHEMATIC DIAGRAMS (23/30)**
DIGITAL UNIT (9/16)

(PAGE 21/30)
TO AUDIO PLD

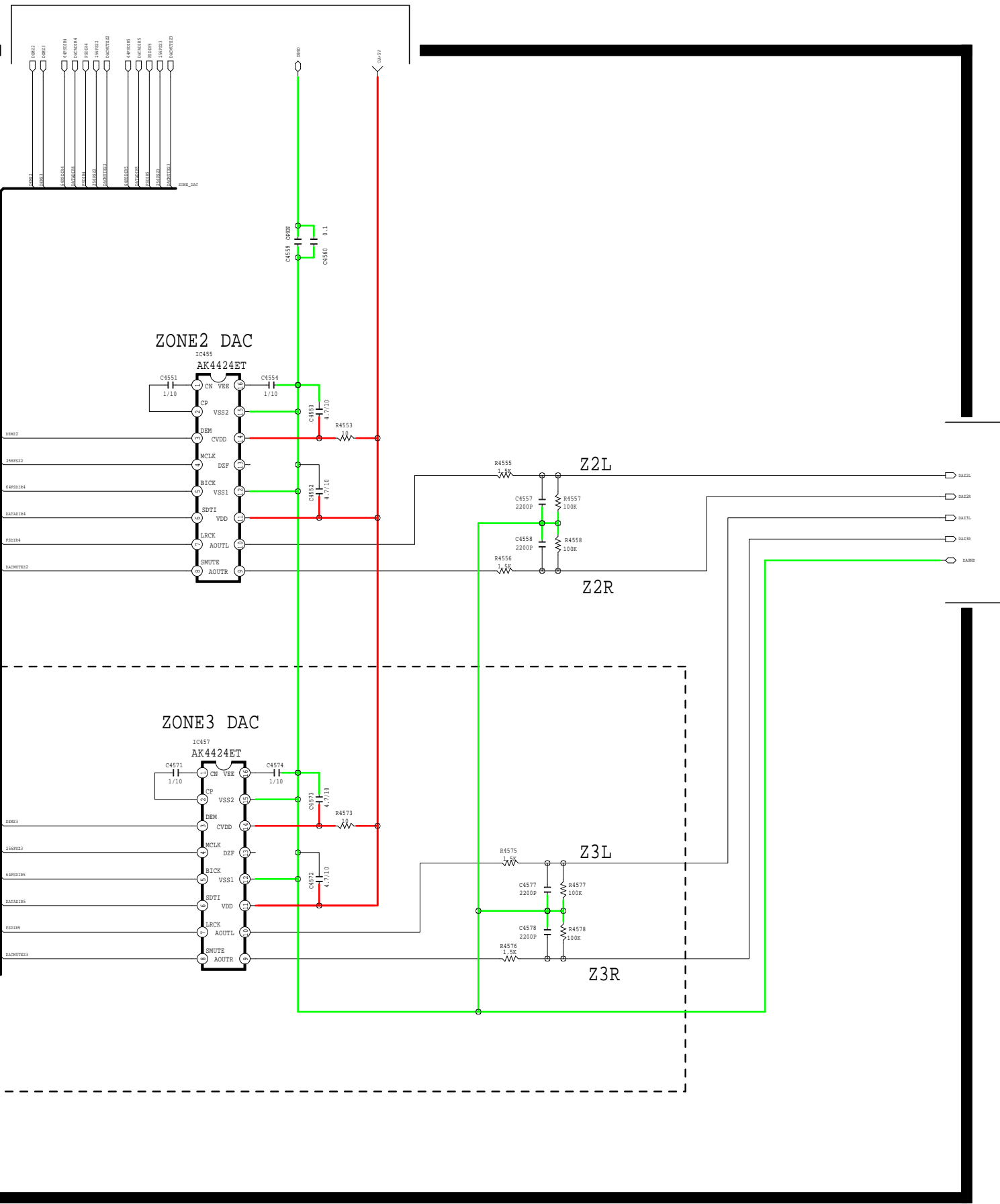

AVR3312 ONLY

TO DIGITAL CONNECT
(PAGE 15/30)

— GND — POWER + — POWER - - - - STBY POWER

⚠ SCHEMATIC DIAGRAMS (24/30)
DIGITAL UNIT (10/16)

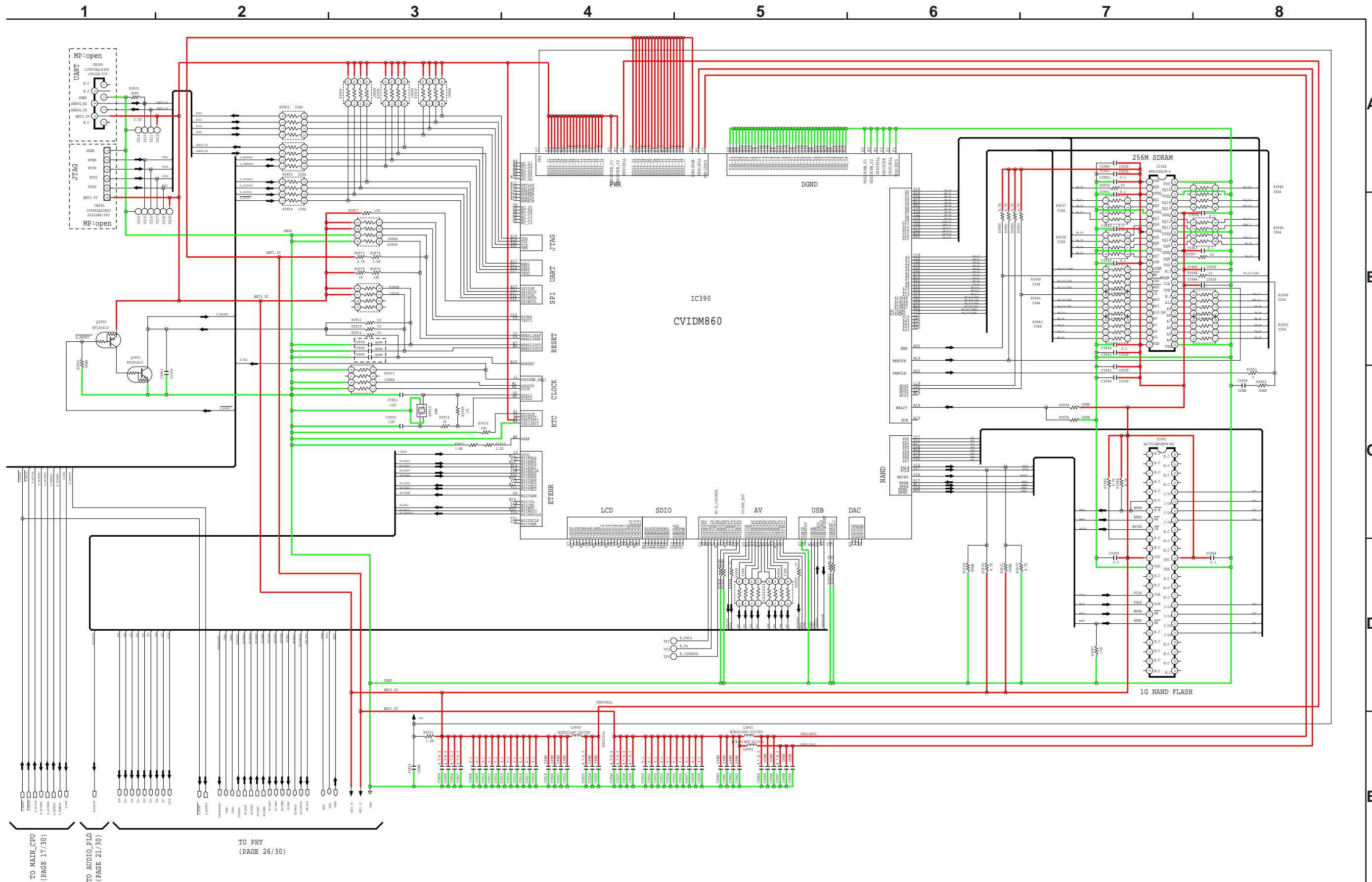

TO MAIN_CPU
(PAGE 17/30)

TO AUDIO_PLD
(PAGE 21/30)

TO PHY
(PAGE 26/30)

△ SCHEMATIC DIAGRAMS (25/30)
DIGITAL UNIT (11/16)

— GND — POWER + — POWER - - - - STBY POWER

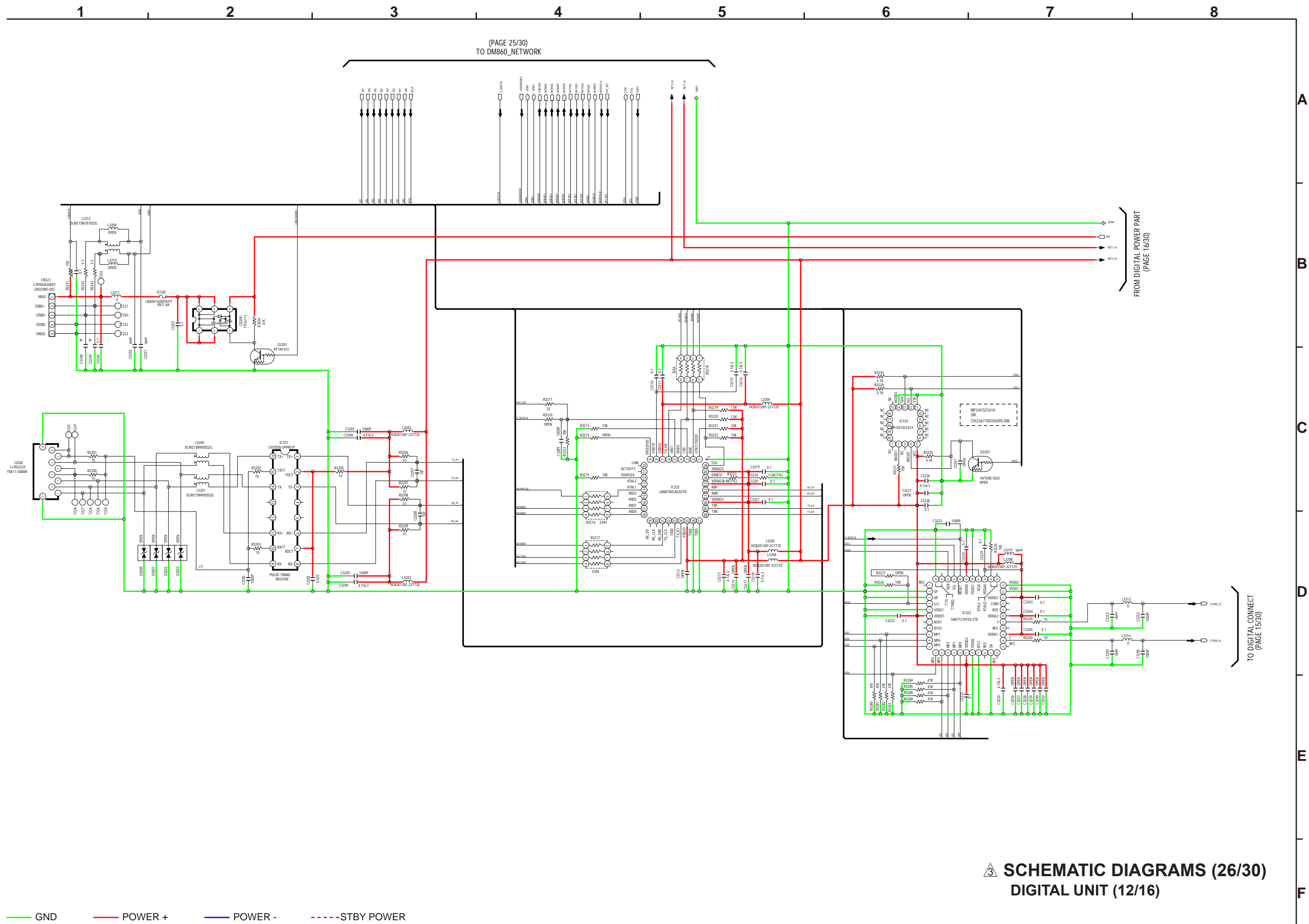

3 SCHEMATIC DIAGRAMS (26/30)
DIGITAL UNIT (12/16)

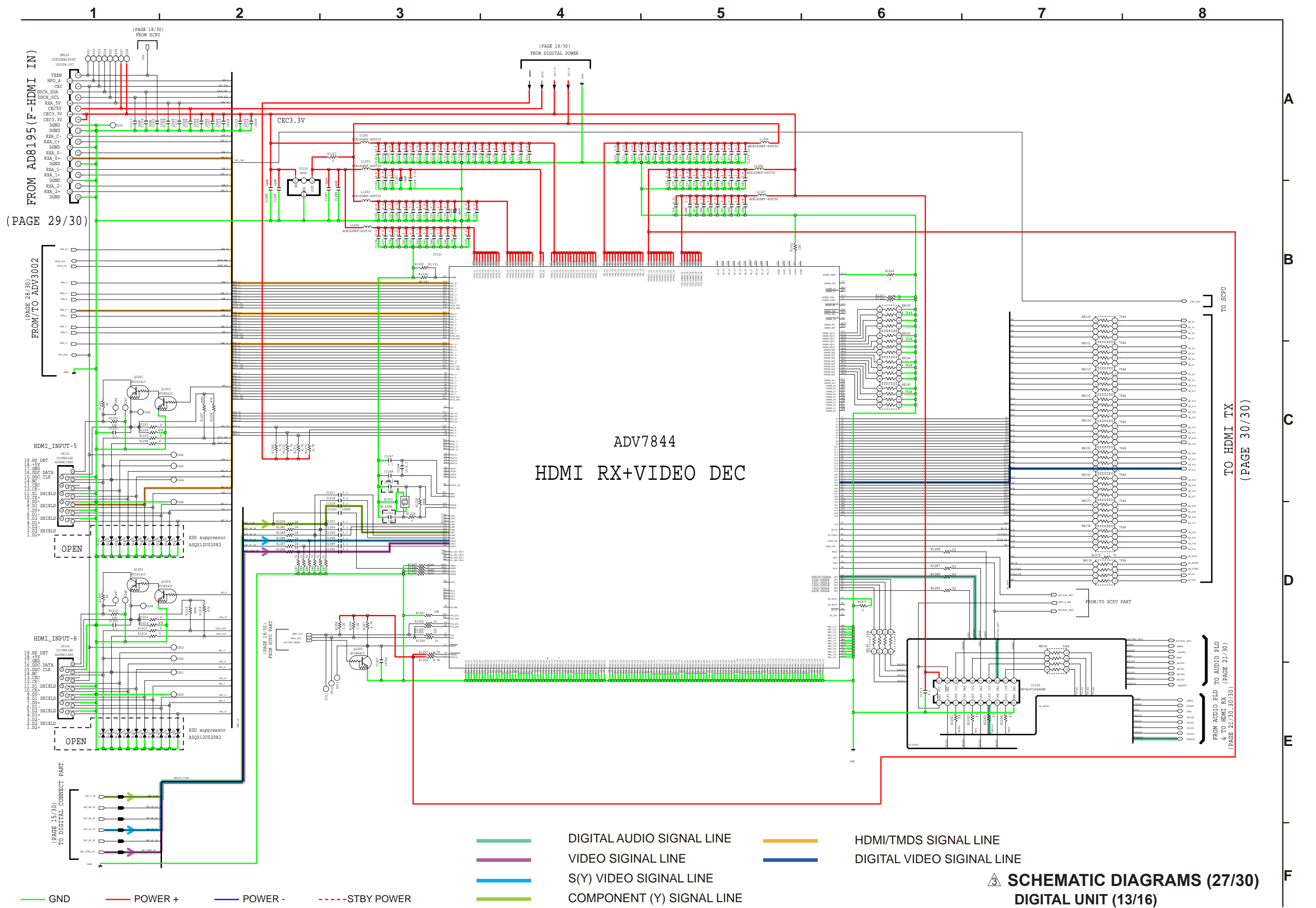

SCHEMATIC DIAGRAMS (27/30)
DIGITAL UNIT (13/16)

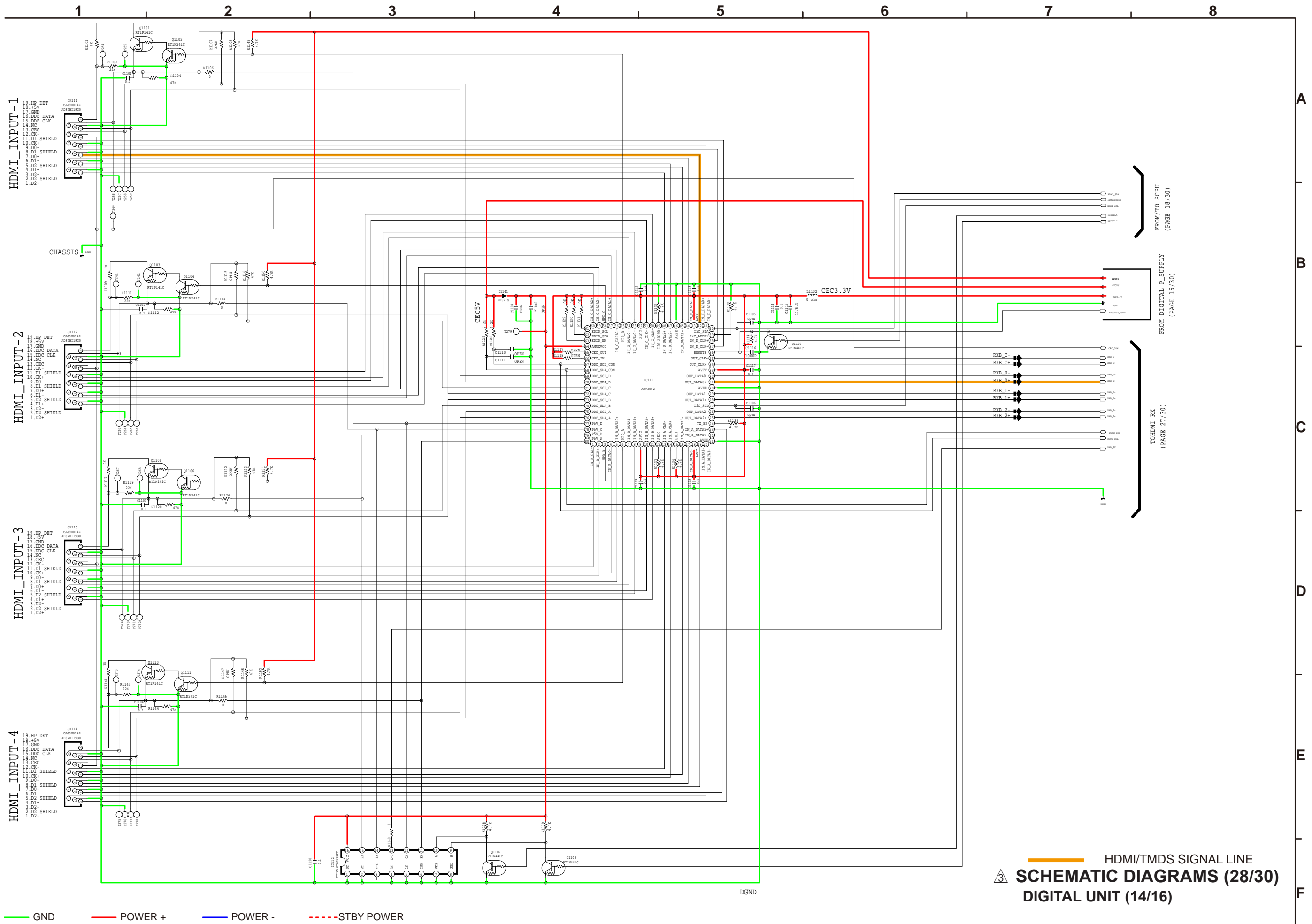

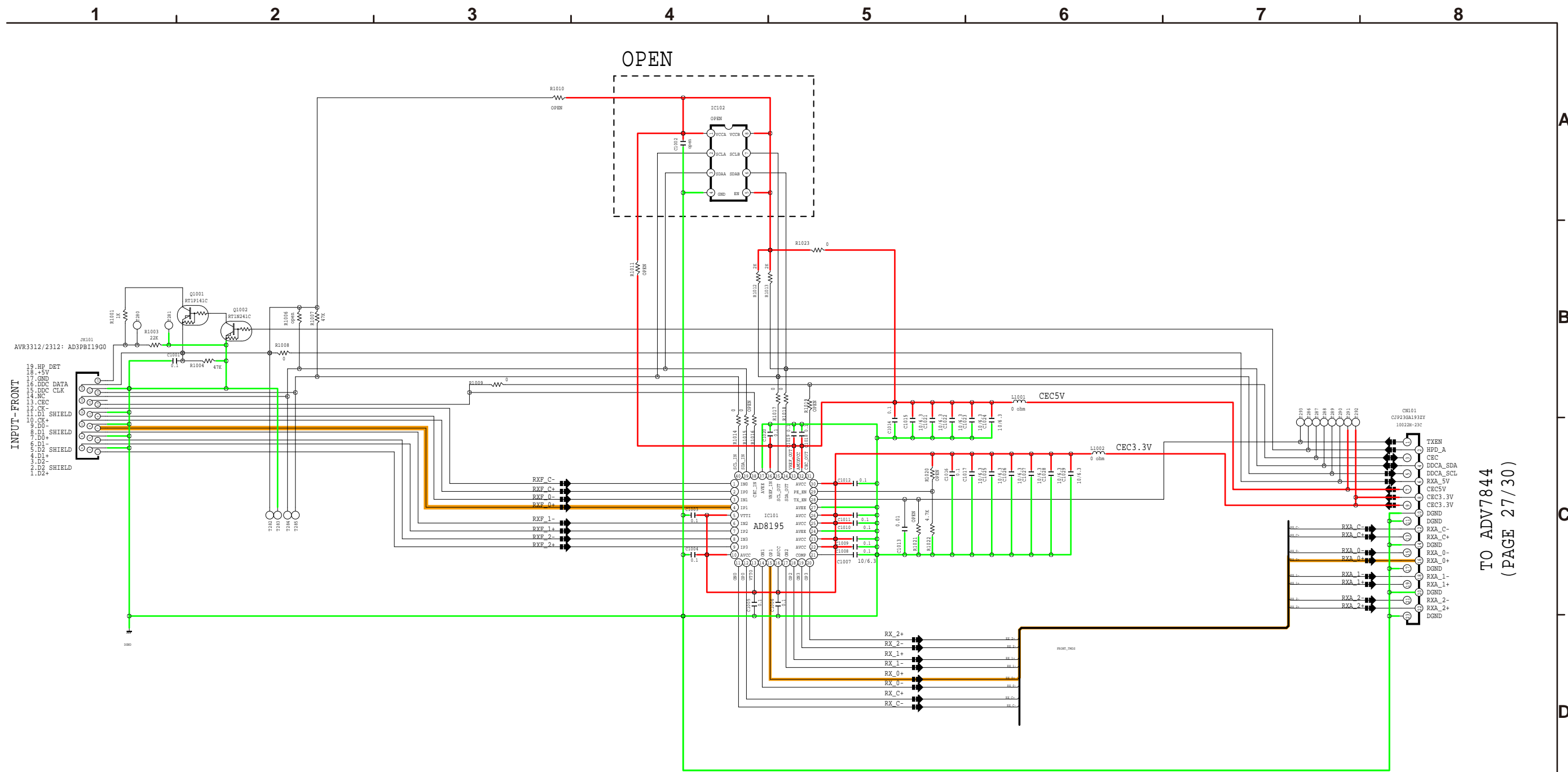

OPEN

TO ADV7844
(PAGE 27/30)

— HDMI/TMDS SIGNAL LINE

3 SCHEMATIC DIAGRAMS (29/30)
DIGITAL UNIT (15/16)

— GND — POWER + — POWER - - - - STBY POWER

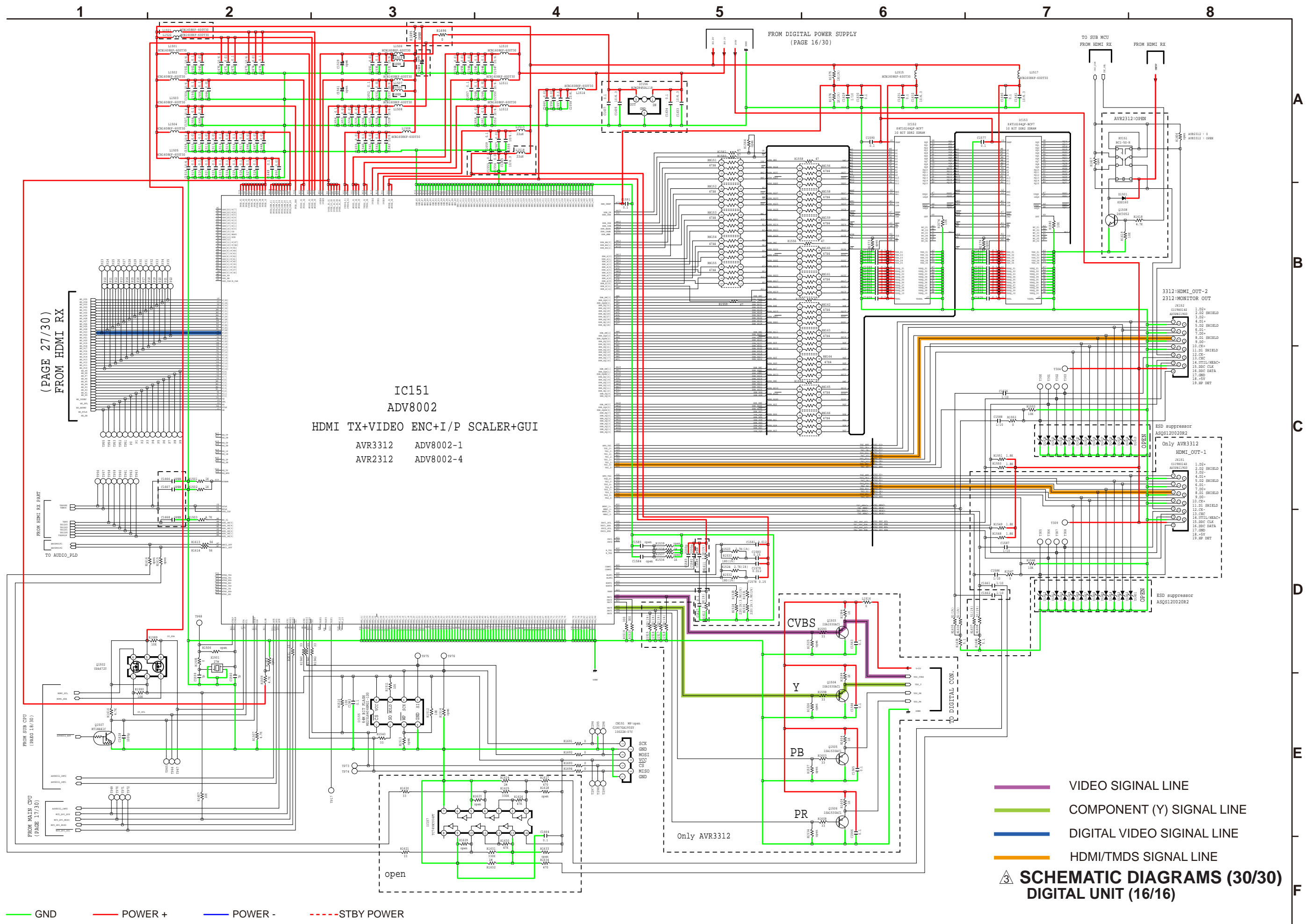

WIRING DIAGRAM

