

SERVICE MANUAL

MODEL	JP	E3	E2	EK	E2A	E1C	EUT
AVR-1708		✓	✓				
AVR-1508		✓	✓				✓
AVR-688		✓					
AVR-588		✓					
AVR-488		✓					
AVC-1508	✓						

AV SURROUND RECEIVER AV SURROUND AMPLIFIER

注意

サービスをおこなう前に、このサービスマニュアルを必ずお読みください。本機は、火災、感電、けがなどに対する安全性を確保するために、さまざまな配慮をおこなっており、また法的には「電気用品安全法」にもとづき、所定の許可を得て製造されております。従ってサービスをおこなう際は、これらの安全性が維持されるよう、このサービスマニュアルに記載されている注意事項を必ずお守りください。

For purposes of improvement, specifications and design are subject to change without notice.

本機の仕様は性能改良のため、予告なく変更することがあります。
補修用性能部品の保有期間は、製造打切後 8 年です。

Please use this service manual with referring to the operating instructions without fail.

修理の際は、必ず取扱説明書を参照の上、作業を行ってください。

Some illustrations using in this service manual are slightly different from the actual set.

本文中に使用しているイラストは、説明の都合上現物と多少異なる場合があります。

DENON

Denon Brand Company, D&M Holdings Inc.

SAFETY PRECAUTIONS

The following check should be performed for the continued protection of the customer and service technician.

LEAKAGE CURRENT CHECK

Before returning the unit to the customer, make sure you make either (1) a leakage current check or (2) a line to chassis resistance check. If the leakage current exceeds 0.5 milliamps, or if the resistance from chassis to either side of the power cord is less than 460 kohms, the unit is defective.

CAUTION Please heed the points listed below during servicing and inspection.

⊙ Heed the cautions!

Spots requiring particular attention when servicing, such as the cabinet, parts, chassis, etc., have cautions indicated on labels or seals. Be sure to heed these cautions and the cautions indicated in the handling instructions.

⊙ Caution concerning electric shock!

- (1) An AC voltage is impressed on this set, so touching internal metal parts when the set is energized could cause electric shock. Take care to avoid electric shock, by for example using an isolating transformer and gloves when servicing while the set is energized, unplugging the power cord when replacing parts, etc.
- (2) There are high voltage parts inside. Handle with extra care when the set is energized.

⊙ Caution concerning disassembly and assembly!

Though great care is taken when manufacturing parts from sheet metal, there may in some rare cases be burrs on the edges of parts which could cause injury if fingers are moved across them. Use gloves to protect your hands.

⊙ Only use designated parts!

The set's parts have specific safety properties (fire resistance, voltage resistance, etc.). For replacement parts, be sure to use parts which have the same properties. In particular, for the important safety parts that are marked \triangle on wiring diagrams and parts lists, be sure to use the designated parts.

⊙ Be sure to mount parts and arrange the wires as they were originally!

For safety reasons, some parts use tape, tubes or other insulating materials, and some parts are mounted away from the surface of printed circuit boards. Care is also taken with the positions of the wires inside and clamps are used to keep wires away from heating and high voltage parts, so be sure to set everything back as it was originally.

⊙ Inspect for safety after servicing!

Check that all screws, parts and wires removed or disconnected for servicing have been put back in their original positions, inspect that no parts around the area that has been serviced have been negatively affected, conduct an insulation check on the external metal connectors and between the blades of the power plug, and otherwise check that safety is ensured.

(Insulation check procedure)

Unplug the power cord from the power outlet, disconnect the antenna, plugs, etc., and turn the power switch on. Using a 500V insulation resistance tester, check that the insulation resistance between the terminals of the power plug and the externally exposed metal parts (antenna terminal, headphones terminal, microphone terminal, input terminal, etc.) is $1M\Omega$ or greater. If it is less, the set must be inspected and repaired.

CAUTION Concerning important safety parts

Many of the electric and structural parts used in the set have special safety properties. In most cases these properties are difficult to distinguish by sight, and using replacement parts with higher ratings (rated power and withstand voltage) does not necessarily guarantee that safety performance will be preserved. Parts with safety properties are indicated as shown below on the wiring diagrams and parts lists in this service manual. Be sure to replace them with parts with the designated part number.

- (1) Schematic diagrams ... Indicated by the \triangle mark.
- (2) Parts lists ... Indicated by the \triangle mark.

Using parts other than the designated parts could result in electric shock, fires or other dangerous situations.

注意 サービス、点検時にはつぎのことにご注意願います。

◎注意事項をお守りください！

サービスのとき特に注意を必要とする個所についてはキャビネット、部品、シャーシなどにラベルや捺印で注意事項を表示しています。これらの注意書きおよび取扱説明書などの注意事項を必ずお守りください。

◎感電に注意！

- (1) このセットは、交流電圧が印加されていますので通電時に内部金属部に触れると感電することがあります。従って通電サービス時には、絶縁トランスの使用や手袋の着用、部品交換には、電源プラグを抜くなどして感電にご注意ください。
- (2) 内部には高電圧の部分がありますので、通電時の取扱には十分ご注意ください。

◎分解、組み立て作業時のご注意！

板金部品の端面の『バリ』は、部品製造時に充分管理をしておりますが、板金端面は鋭利となっている箇所がありますので、部品端面に触れたまま指を動かすとまれに怪我をする場合がありますので十分注意して作業して下さい。手の保護のために手袋を着用して下さい。

◎指定部品の使用！

セットの部品は難燃性や耐電圧など安全上の特性を持ったものとなっています。従って交換部品は、使用されていたものと同じ特性の部品を使用して下さい。特に配線図、部品表に △ 印で指定されている安全上重要な部品は必ず指定のものをご使用ください。

◎部品の取付けや配線の引きまわしは、元どおりに！

安全上、テープやチューブなどの絶縁材料を使用したり、プリント基板から浮かして取付けた部品があります。また内部配線は引きまわしやクランパーによって発熱部品や高圧部品に接近しないように配慮されていますので、これらは必ず元どおりにして下さい。

◎サービス後は安全点検を！

サービスのために取り外したねじ、部品、配線などが元どおりになっているか、またサービスした個所の周辺を劣化させてしまったところがないかなどを点検し、外部金属端子部と、電源プラグの刃の間の絶縁チェックをおこなうなど、安全性が確保されていることを確認してください。

(絶縁チェックの方法)

電源コンセントから電源プラグを抜き、アンテナやプラグなどを外し、電源スイッチを入れます。500V 絶縁抵抗計を用いて、電源プラグのそれぞれの端子と外部露出金属部 [アンテナ端子、ヘッドホン端子、マイク端子、入力端子など] との間で、絶縁抵抗値が 1 MΩ 以上であることを確認してください。この値以下のときはセットの点検修理が必要です。

注意 安全上重要な部品について

本機に使用している多くの電気部品、および機構部品は安全上、特別な特性を持っています。この特性はほとんどの場合、外観では判別つきにくく、またもとの部品より高い定格（定格電力、耐圧）を持ったものを使用しても安全性が維持されるとは、限りません。安全上の特性を持った部品は、このサービスマニュアルの配線図、部品表につぎのように表示していますので必ず指定されている部品番号のものを使用願います。

- (1) 配線図… △ マークで表示しています。
- (2) 部品表… △ マークで表示しています。

指定された部品と異なるものを使用した場合には、感電、火災などの危険を生じる恐れがあります。

DIMENSION
AVR-1708 model

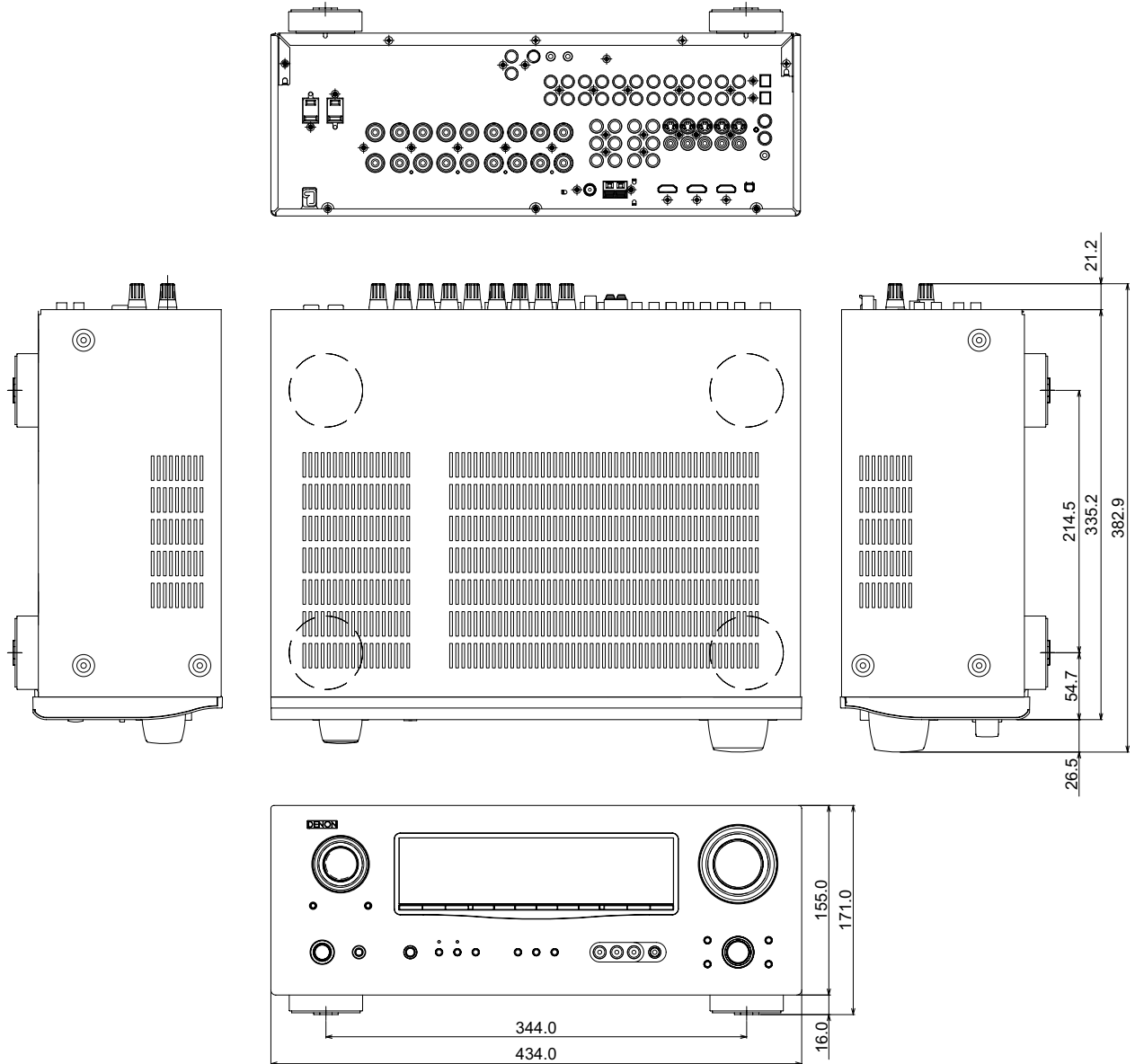

AVR-1508 / AVC-1508 model

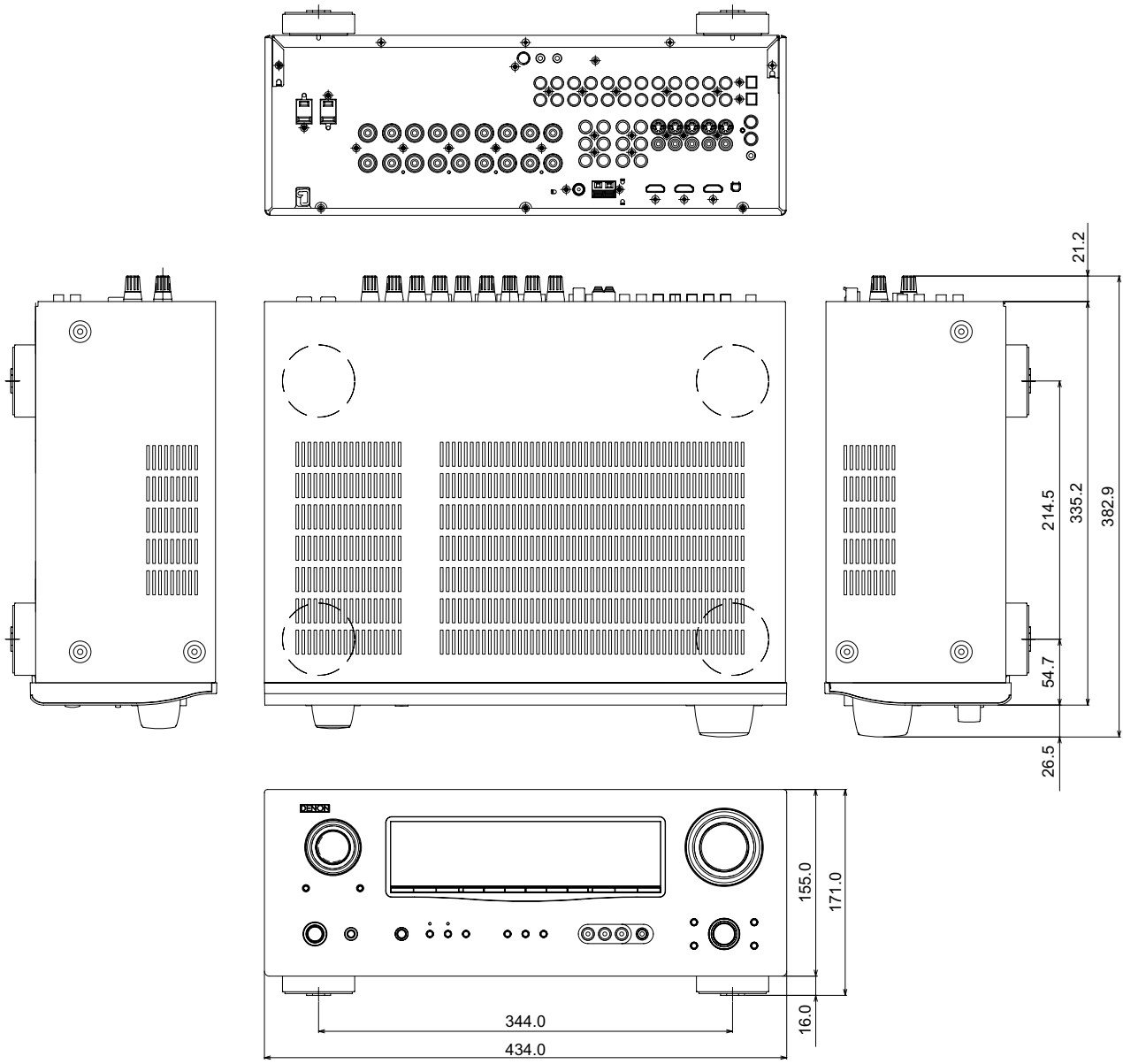

AVR-688 model

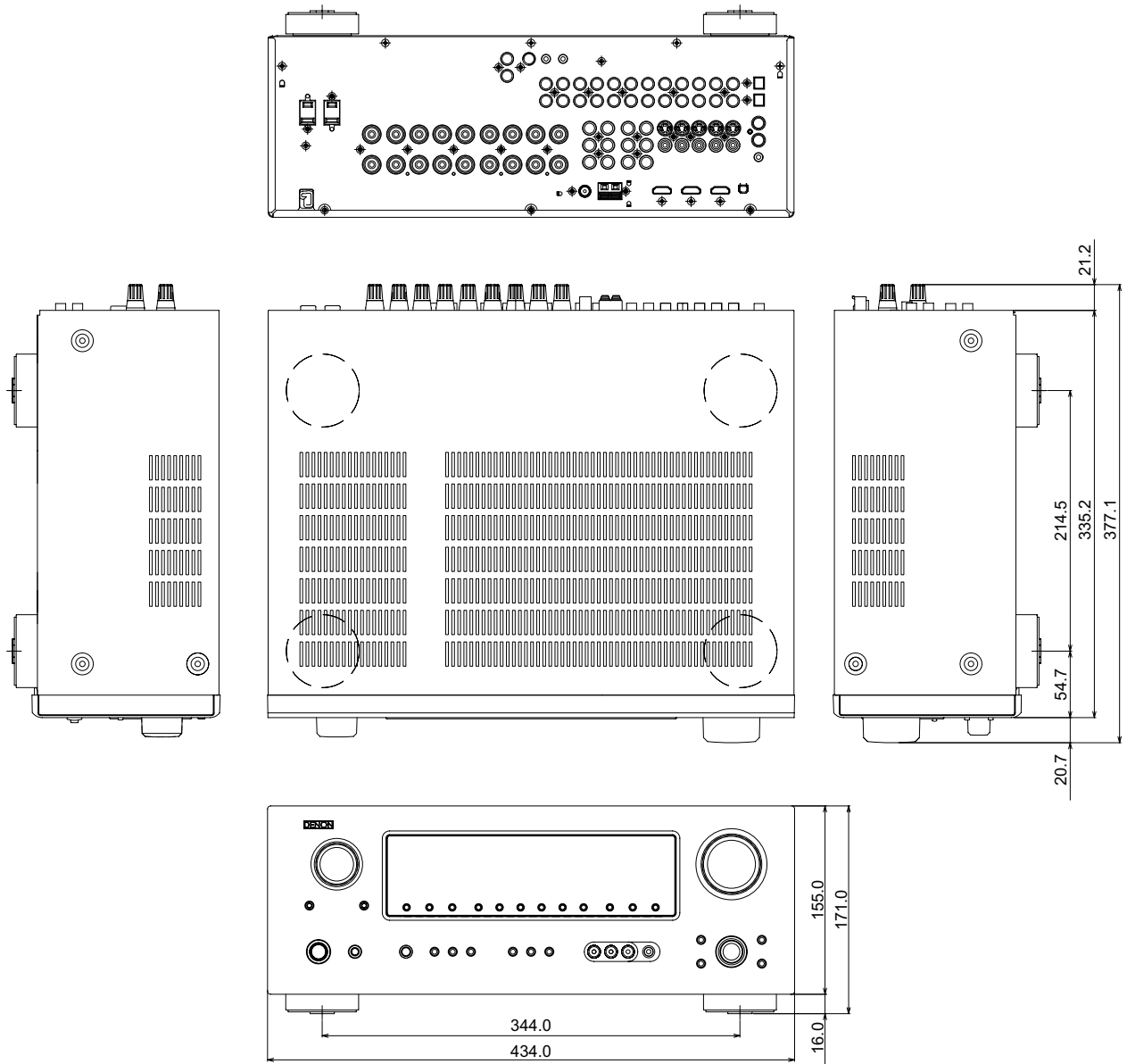

AVR-588 model

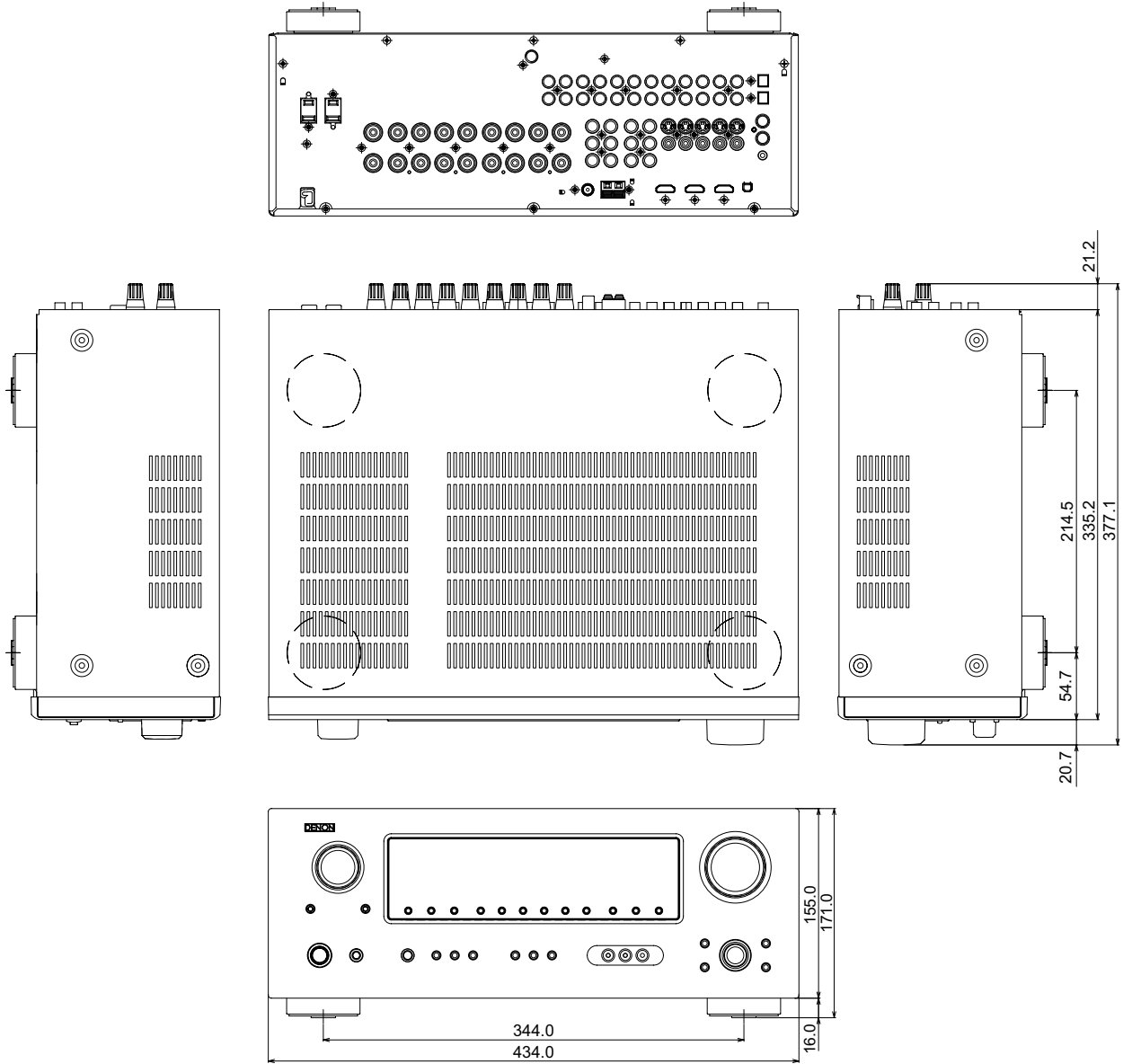

AVR-488 model

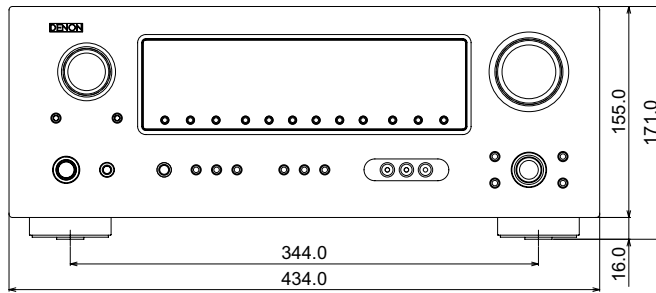
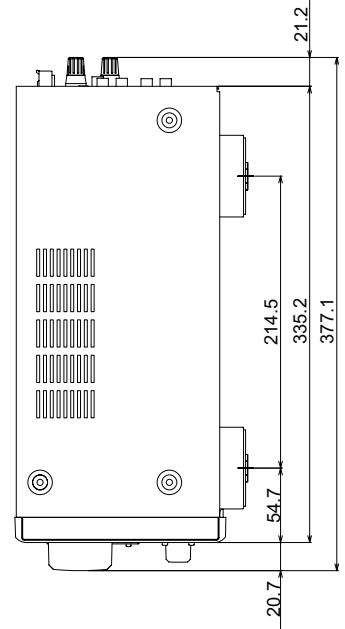
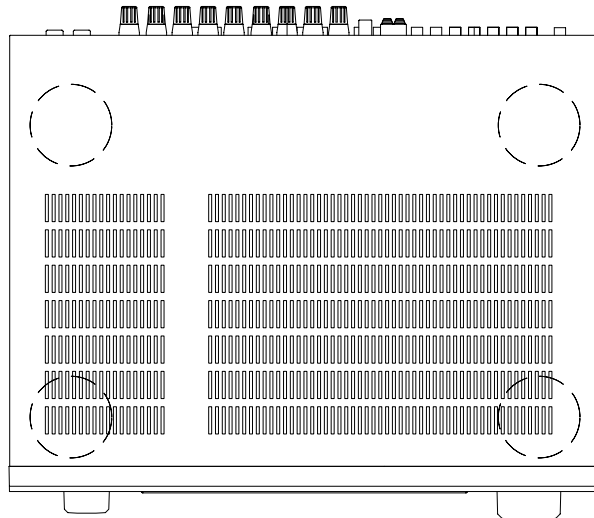
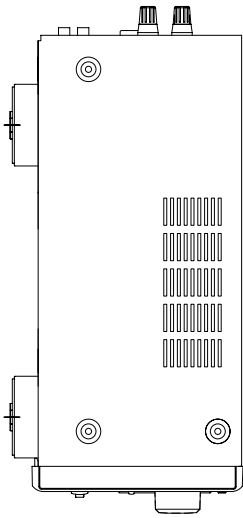
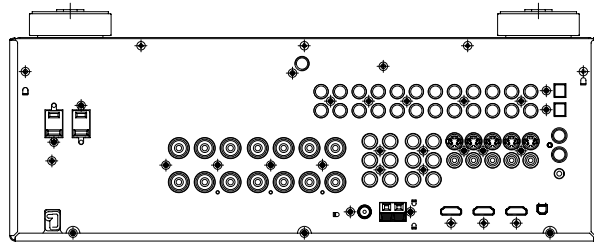

CAUTION IN SERVICING

Initializing AV SURROUND RECEIVER/AMPLIFIER

AV SURROUND RECEIVER/AMPLIFIER initialization should be performed when the μ com, peripheral parts of μ com, and Digital P.W.B. are replaced.

1. Switch off the unit.
2. Hold the following SPEAKERS-A button and SPEAKERS-B button, and switch on the unit.
3. Check that the entire display is flashing with an interval of about 1 second, and release your fingers from the 2 buttons and the microprocessor will be initialized.

Note: • If step 3 does not work, start over from step 1.
• All user settings will be lost and this factory setting will be recovered when this initialization mode. So make sure to memorize your setting for restoring after the initialization.

サービス時の注意事項

AV サラウンドレシーバー / アンプの初期化について

マイコンやマイコン周辺部品、Digital 基板等を交換した場合は、AV サラウンドレシーバー / アンプの初期化を行って下さい。

1. on/off ボタンを OFF にします。
2. SPEAKERS-A ボタンと SPEAKERS-B ボタンを同時に押しながら、on/off ボタンを押して ON にします。
3. ディスプレイ表示が約 1 秒間隔で点滅するのを確認後、2つのボタンから指を離します。
*マイコンが初期化されます。

注意: • 上記 3 の状態にならない場合は、もう一度操作 1 からやり直してください。

• 初期化を行うとお客様が設定した内容が工場出荷状態に戻りますので、あらかじめ設定内容を控えておき初期化後再設定してください。

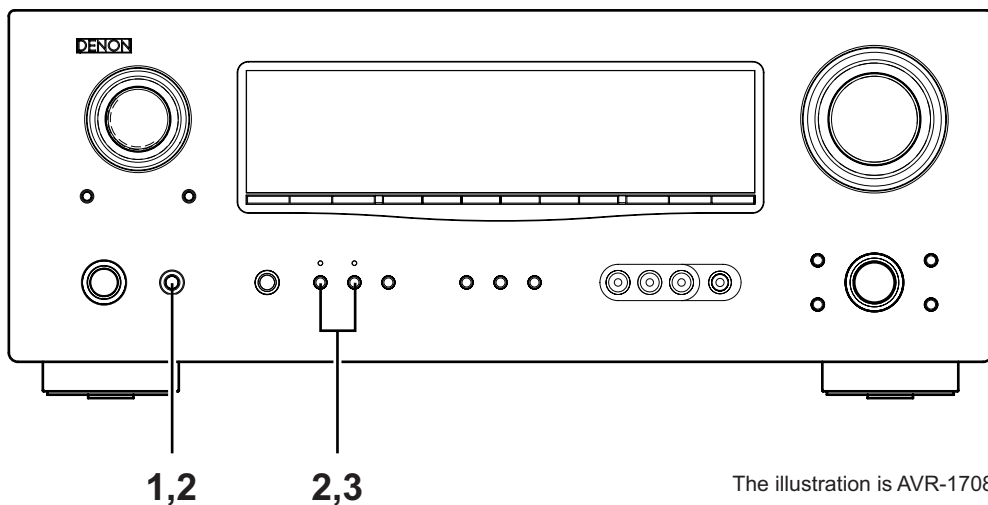

JIG to use for servicing

When you repair the printing board, you can use the following JIG (Extension cable kit). Please order to Denon Official Service Distributor in your region if necessary.

00D SPK- 561 EXTENSION UNIT KIT : 1 Set
00D SPK- 562 9120 CONN. JOINT KIT : 1 Set

△ When you update the firmware, you can use the following JIG (RS232C to internal connector conversion adapter with 8P cable kit). Please order to Denon Official Service Distributor in your region if necessary.

00DSPK-581 WRITING UNIT : 1 Set

サービス時に使用する治具について

基板を修理する際、使用する治具 (延長ケーブルキット) は 下記のとおりです。
必要に応じて販社サービスへ注文下さい。

00D SPK- 561 EXTENSION UNIT KIT : 1 式
00D SPK- 562 9120 CONN. JOINT KIT : 1 式

△ファームウェアをアップデートする際、使用する治具 (RS232C-> 製品内部コネクタ 変換基板 +8P ケーブルキット) は下記のとおりです。
必要に応じて販社サービスへ注文ください。

00DSPK-581 WRITING UNIT : 1 式

DISASSEMBLY

- Disassemble in order of the arrow of the figure of following flow.
下記フロー図の矢印の順番にはずしてください。
- In the case of the re-assembling, assemble it in order of the reverse of the following flow.
再組み立ての場合は、下記のフローの逆の順番に組立ててください
- In the case of the re-assembling, observe "attention of assembling" it.
再組み立ての場合は、「組立のご注意」を遵守してください。

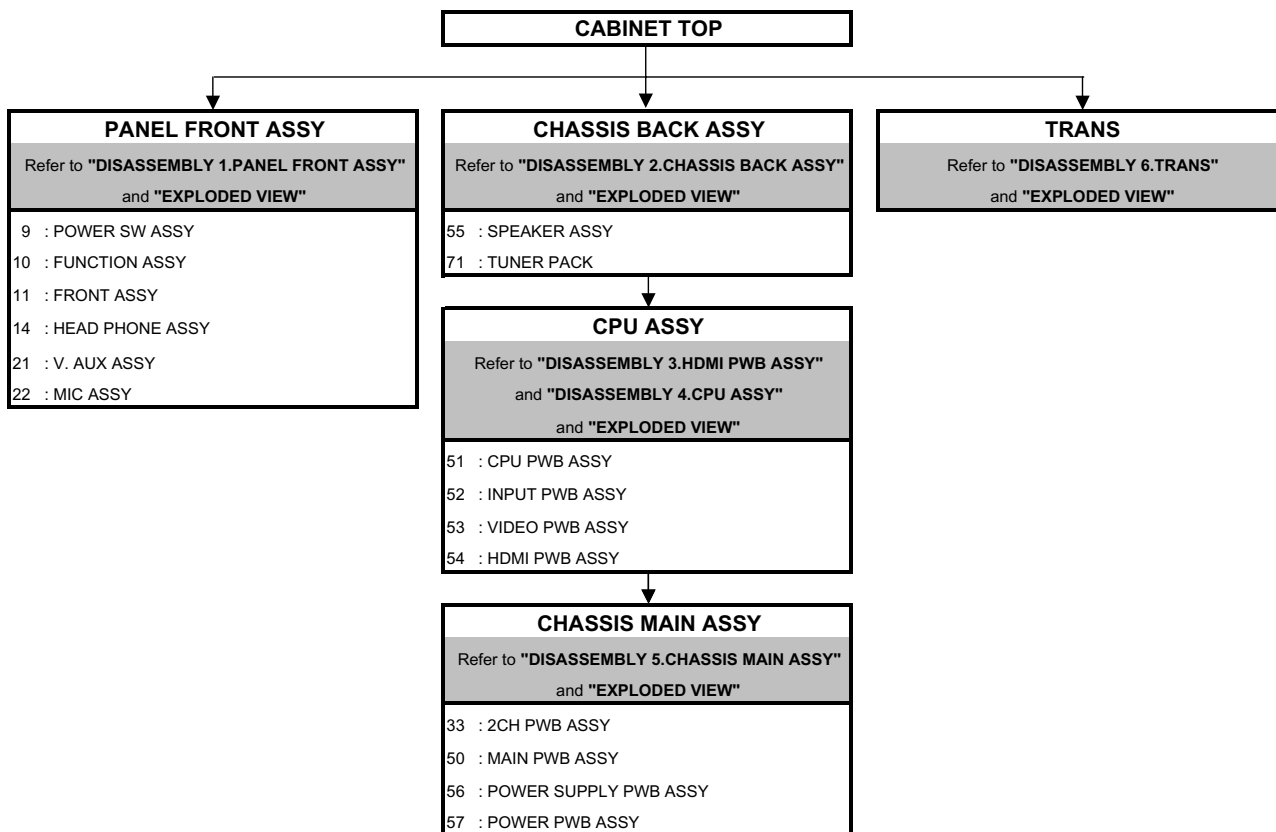

The viewpoint of each photograph
(photography direction)
各図の視点 (撮影方向)

[Top view]

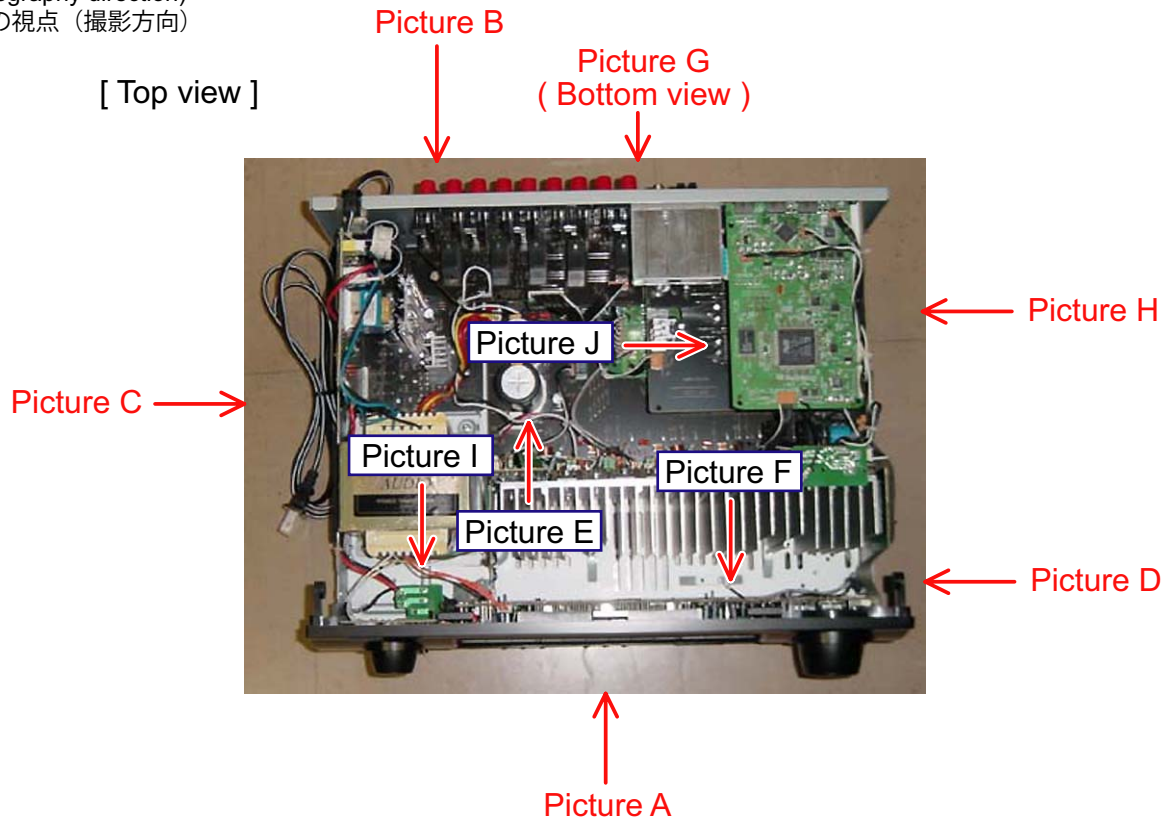

[Top view]

- ★ Cord holder
- ⊕ Wire clamp band

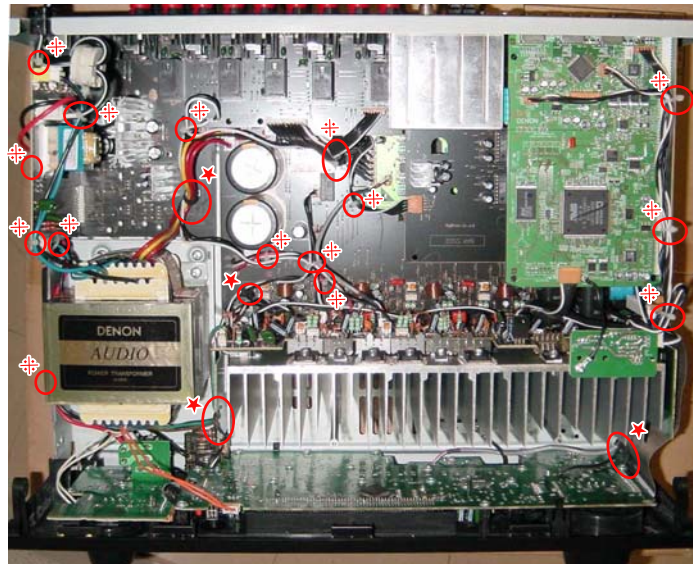

1. PANEL FRONT ASSY

Proceeding (手順) : **CABINET TOP** → **PANEL FRONT ASSY**

(1) Remove the screws. (ねじをはずす。)

Picture A

[Top view]

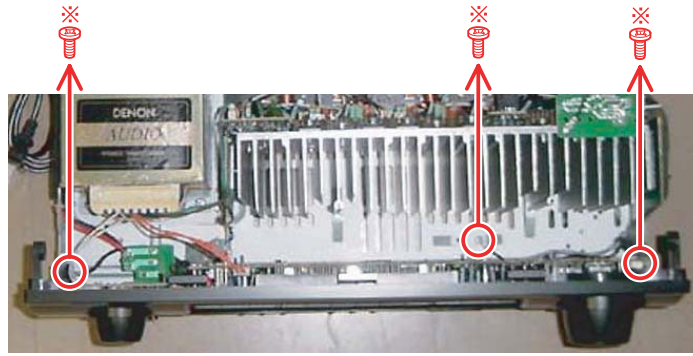

Picture G

[Bottom view]

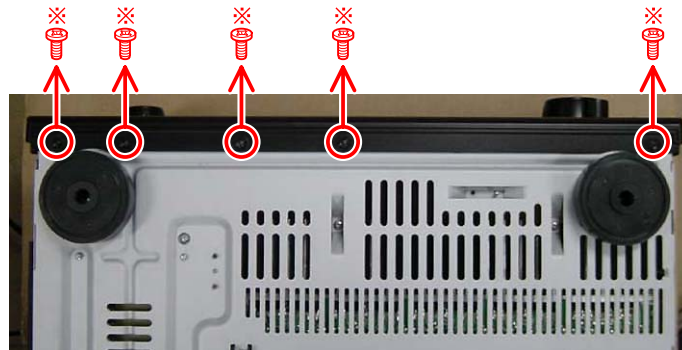

(2) Disconnect the connector wires and remove the screws. (コネクタワイヤーとねじをはずす。)

Picture D

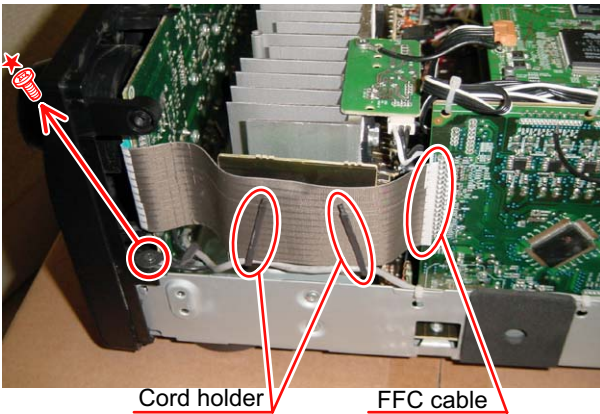

Picture I

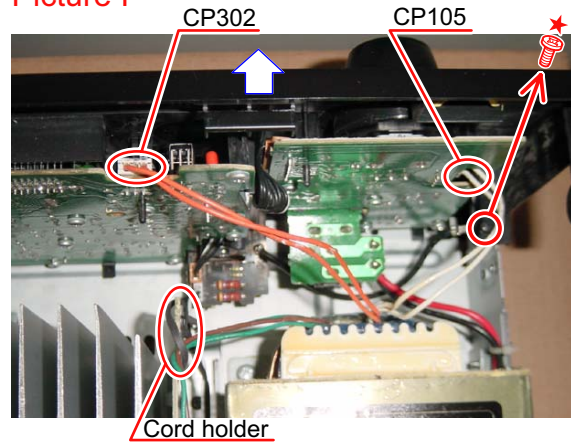

Picture C

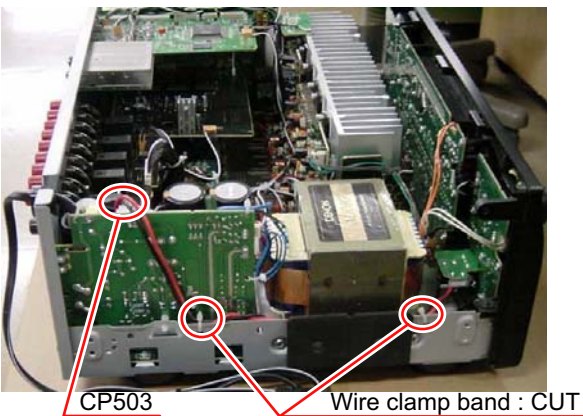

Picture E

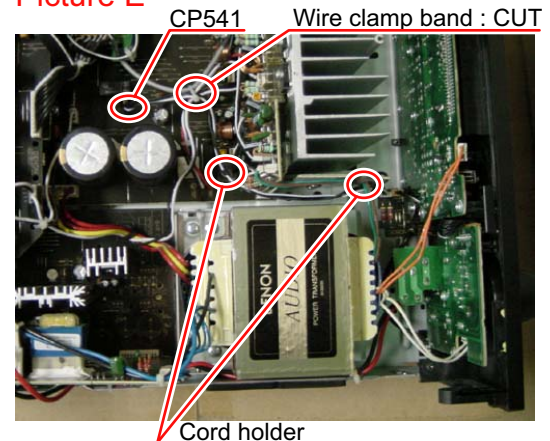

Picture F

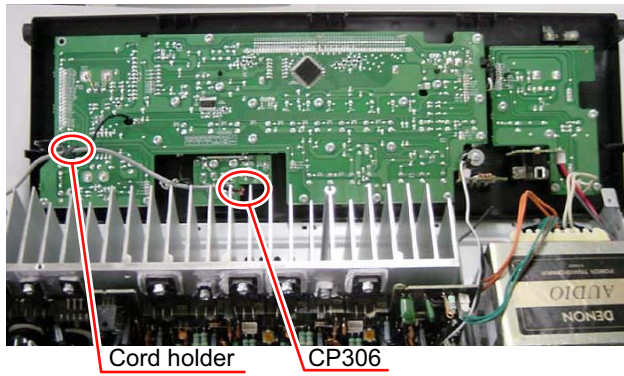

Please refer to "EXPLODED VIEW" for the disassembly method of each P.W.B included in panel front assy.
 Panel front assy の各基板のはずしかたは "EXPLODED VIEW" を参照してください。

2. CHASSIS BACK ASSY

Proceeding (手順) : **CABINET TOP** → **CHASSIS BACK ASSY**

- (1) Disconnect the connector wires and unscrew a screw. (コネクタワイヤーとねじをはずす。)

Picture E

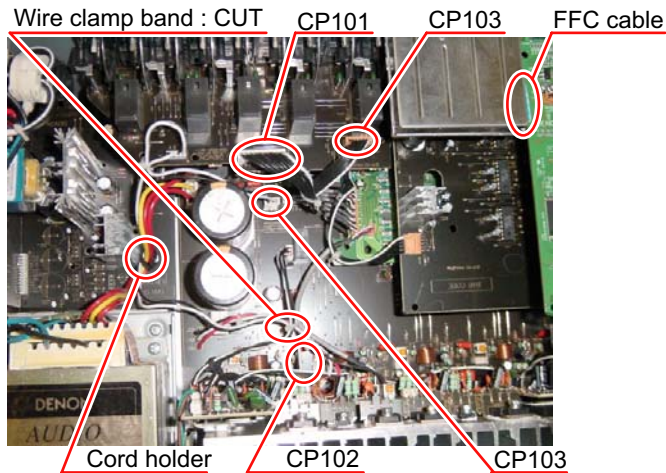

Picture B

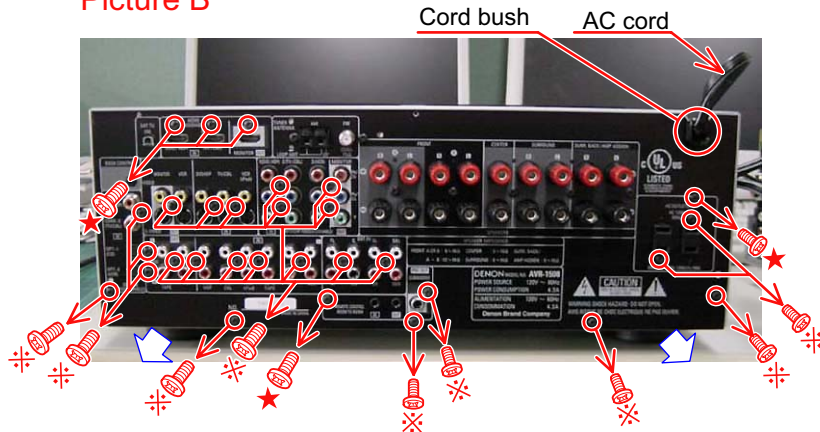

Please refer to "EXPLODED VIEW" for the disassembly method of each P.W.B included in Chassis back assy.
 Chassis back assy の各基板のはずしかたは "EXPLODED VIEW" を参照してください。

3. CPU ASSY

Proceeding (手順) : **CABINET TOP** → **CHASSIS BACK ASSY** → **CPU ASSY**

(1) Disconnect the connector wires and screw. (コネクタワイヤーとねじをはずす。)

Picture H

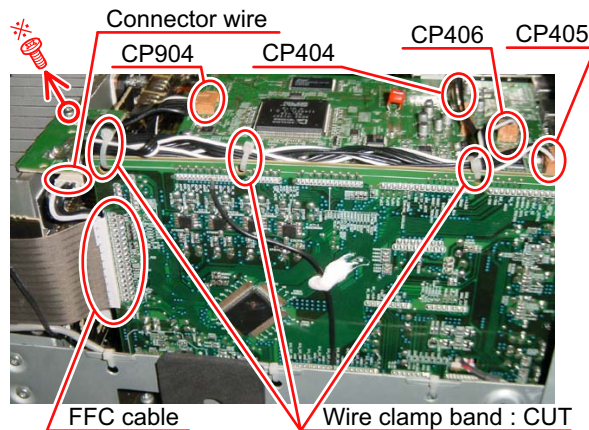

Picture E

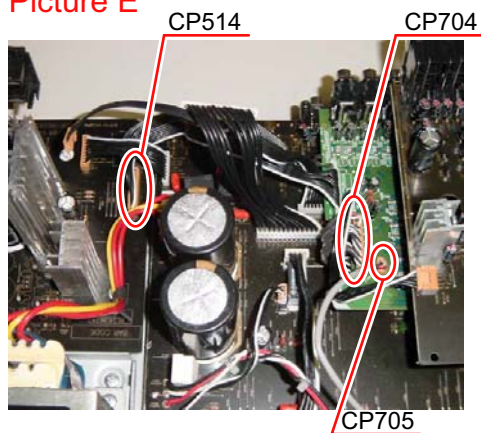

Please refer to "EXPLODED VIEW" for the disassembly method of each P.W.B included in CPU assy.
CPU assy の各基板のはずしかたは "EXPLODED VIEW" を参照してください。

4. CHASSIS MAIN ASSY

Proceeding (手順) : **CABINET TOP** → **CHASSIS BACK ASSY** → **CPU ASSY**
→ **CHASSIS MAIN ASSY**

Please refer to "EXPLODED VIEW" for the disassembly method of each P.W.B included in chassis main assy.
Chassis main assy の各基板のはずしかたは "EXPLODED VIEW" を参照してください。

5. TRANS

Proceeding (手順) : **CABINET TOP** → **TRANS**

(1) Disconnect the connector wires and remove the screws. (コネクタコードとねじをはずす。)

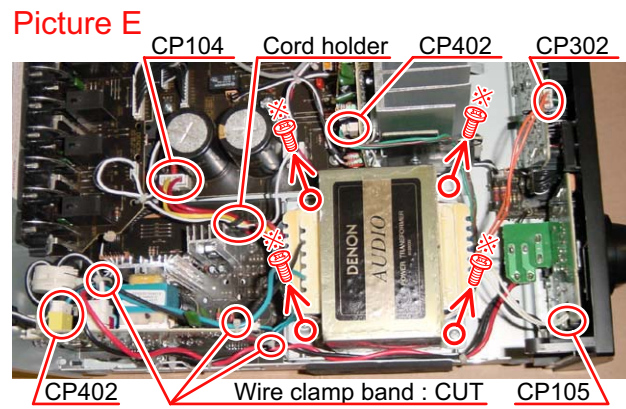

Please refer to "**EXPLODED VIEW**" for the disassembly method of Trans.
Trans のはずしかたは "**EXPLODED VIEW**" を参照してください。

Check mode for μ com/DSP version

μ com/DSP Version Display Mode

1. Operation Spec

μ com/DSP version display mode:

At its starting state, version information is displayed.

Starting method:

E3,EUT,JP model

While pressing 2 buttons, "STATUS " and "DIMMER ", turn on/off button on.

Then, press "STATUS" button to display the following information on the FL Display.

E2 model

While pressing 2 buttons, "RT " and "PTY ", turn on/off button on.

Then, press "RT" button to display the following information on the FL Display.

E3,EUT,JP model

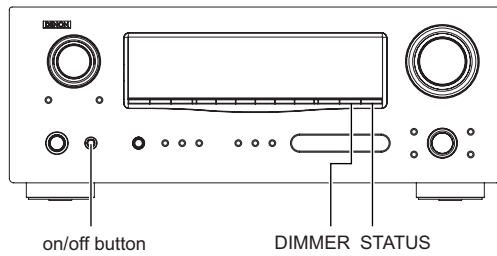

E2 model

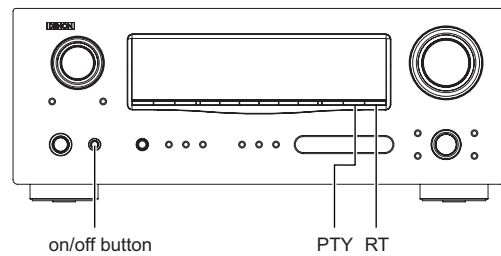

2. Display Order

Destination information → Main- μ com version information → DSP version information

マイコン・DSPバージョンのチェック方法

マイコン・DSPバージョン表示モード

1. 動作仕様

マイコン、DSPバージョン表示モード：

起動状態にて、バージョン情報を表示します。

起動方法：

● E3,EUT,JP モデル

"STATUS", "DIMMER" の2つのボタンを押した状態で、on/off ボタンを押して電源を入れます。

その後、"STATUS" ボタンを押すと下表の内容が FL Display に表示されます。

● E2 モデル

"RT", "PTY" の2つのボタンを押した状態で、on/off ボタンを押して電源を入れます。

その後、"RT" ボタンを押すと下表の内容が FL Display に表示されます。

E3,EUT,JP model

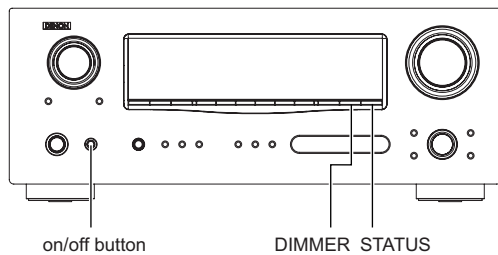

E2 model

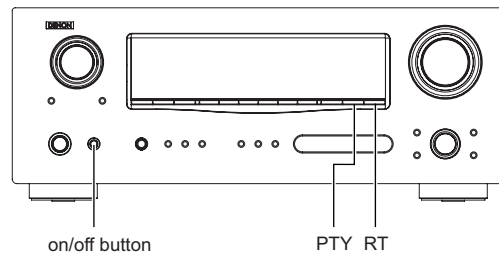

2. 表示順序

仕向地表示 → メインマイコンバージョン情報 → DSPバージョン情報

ADJUSTMENT

Audio Section

Idling Current

Required measurement equipment: DC Voltmeter

1. Preparation

- (1) Avoid direct blow from an air conditioner or an electric fan, and adjust the unit at normal room temperature 15 °C ~ 30 °C (59 °F ~ 86 °F).
- (2) Presetting
 - POWER (Power source switch) OFF
 - SPEAKER (Speaker terminal) No load
(Do not connect speaker, dummy resistor, etc.)

2. Adjustment

- (1) Remove top cover and set VR101 FL, FR, C, SL, SR, on Main Amp. Unit, VR401, VR402 on 2ch- Amp. Unit at fully counterclockwise (⌚) position.
- (2) Connect DC Voltmeter to test points (FRONT-Lch: TP101, FRONT-Rch: TP105, CENTER ch: TP103, SURROUND-Lch: TP102, SURROUND-Rch: TP104, SURROUND-BACK Lch: TP401, SURROUND-BACK Rch: TP402).
- (3) Connect power cord to AC Line, and turn power switch "ON".
- (4) Presetting.
MASTER VOLUME : "---" counterclockwise (⌚ min.)
SPEAKER (Speaker terminal) : No load
(Do not connect speaker, dummy resistor, etc.)
MODE : 7CH STEREO
FUNCTION : CD
- (5) Within 2 minutes after the power on, turn VR101 clockwise (⌚) to adjust the TEST POINT voltage to 1.5 mV ± 0.5 mV DC.
- (6) After 10 minutes from the preset above, turn VR101 to set the voltage to 2.0 mV ± 0.5 mV DC.
- (7) Adjust the Variable Resistors of other channels in the same way.

調整

オーディオセクション

アイドリング電流の調整

調整に必要な測定器： DC Voltmeter

1. 準備

- (1) セットをクーラ、扇風機のそばなど風通しの良い場所を避け、通常の使用状態に置きます。セットの周囲温度は 15 ~ 30 °C、湿度は常湿とします。
- (2) プリセット
 - 電源スイッチ OFF
 - スピーカ端子 無負荷
(スピーカ・ダミー抵抗器などを接続しない。)

2. 調整

- (1) 上カバーをはずし、メインアンプ基板の VR101 FL, FR, C, SL, SR 及び 2ch- アンプ基板の VR401, VR402 を反時計方向 (⌚) に回し切った状態にセットします。
- (2) テストポイント (FRONT-Lch: TP101, FRONT-Rch: TP105, CENTER ch: TP103, SURROUND-Lch: TP102, SURROUND-Rch: TP104, SURROUND-BACK Lch: TP401, SURROUND-BACK Rch: TP402) に DC Voltmeter を接続します。
- (3) 電源コードを AC100V (95 ~ 105V の範囲でも可) に接続し、電源スイッチを "ON" にします。
- (4) ON 後、次のようにセットします。
 - MASTER VOLUME (音量調節つまみ) →反時計方向 (⌚) に回す、最小の状態にする。
 - SPEAKER (スピーカ端子) →無負荷 (スピーカ、ダミー抵抗器などを接続しない。)MODE : 7CH STEREO
FUNCTION : CD
- (5) 2分以内に VR101 を時計方向 (⌚) に回しテストポイントの電圧を次のように調整します。
1.5mV ± 0.5mV DC
- (6) 予備調整から 10分後 VR101 を回し、次のように電圧を設定します。
2.0mV ± 0.5mV DC
- (7) 同じ方法で各チャンネルの可変抵抗を調整します。

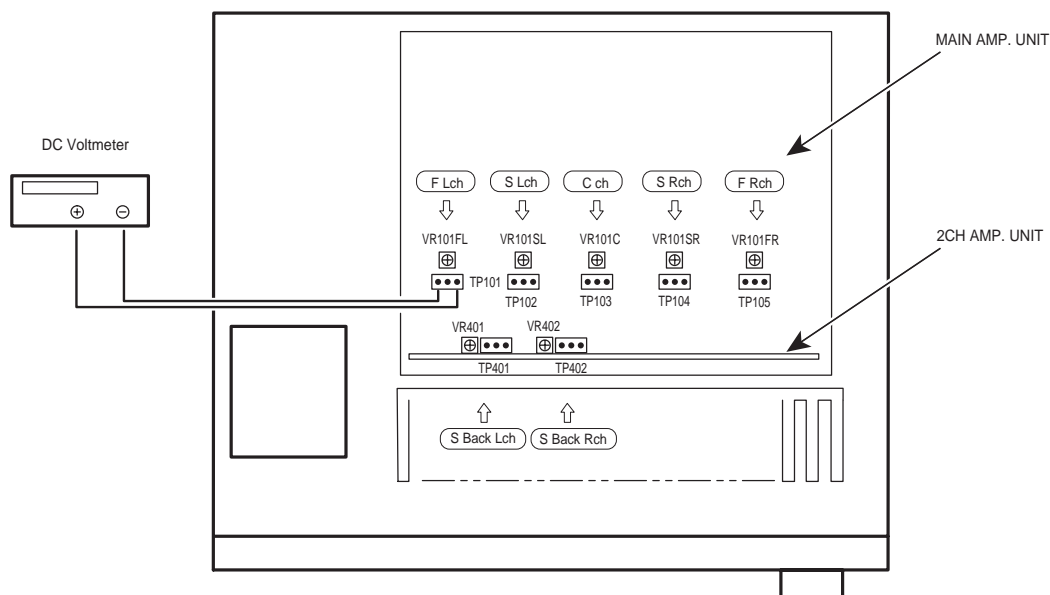

TROUBLE SHOOTING

1. POWER

1.1. Power not turn on

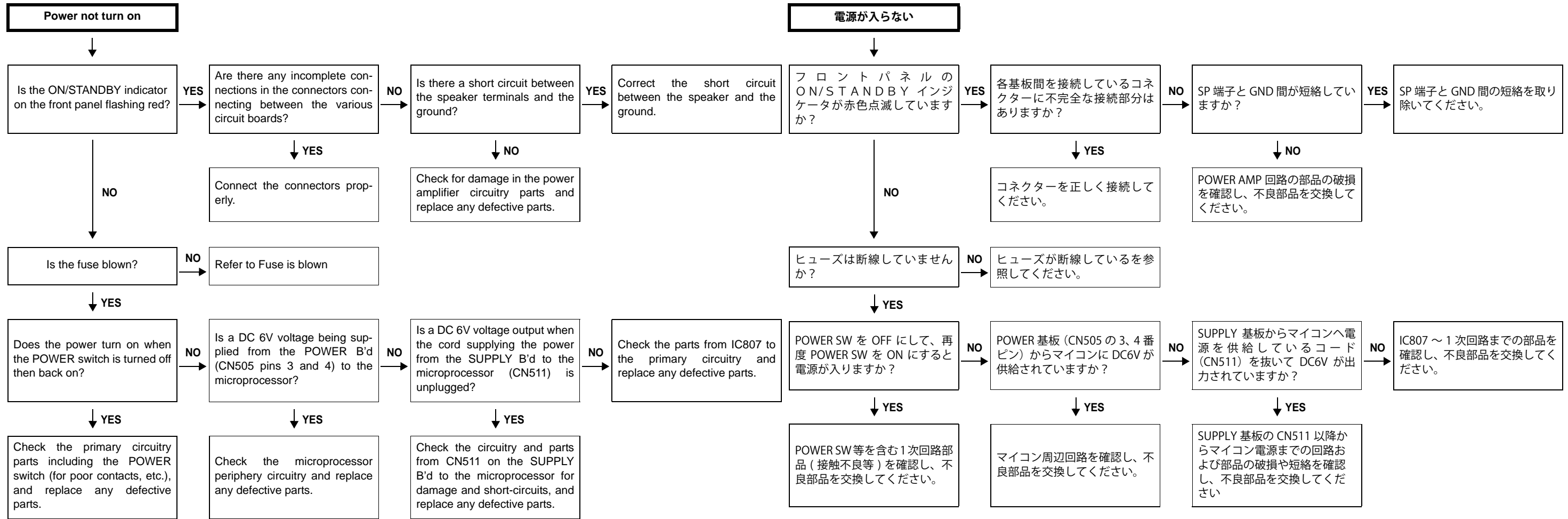

1.2. Fuse is blown

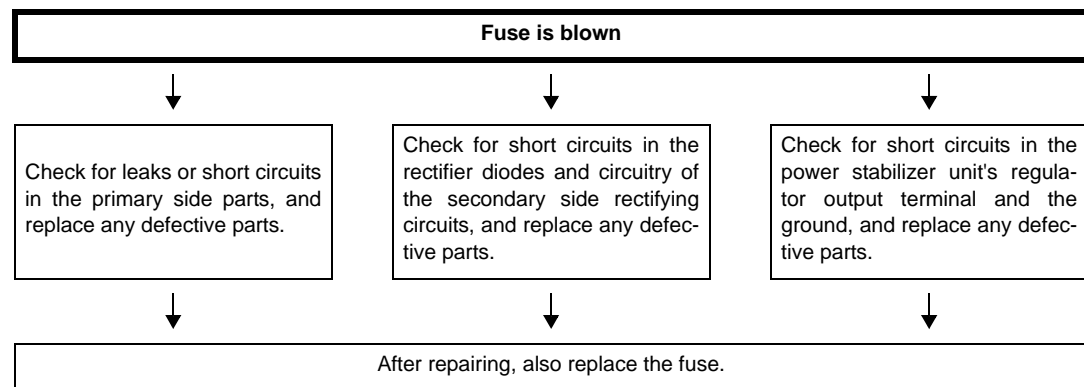

トラブルシューティング

1. 電源

1.1. 電源が入らない

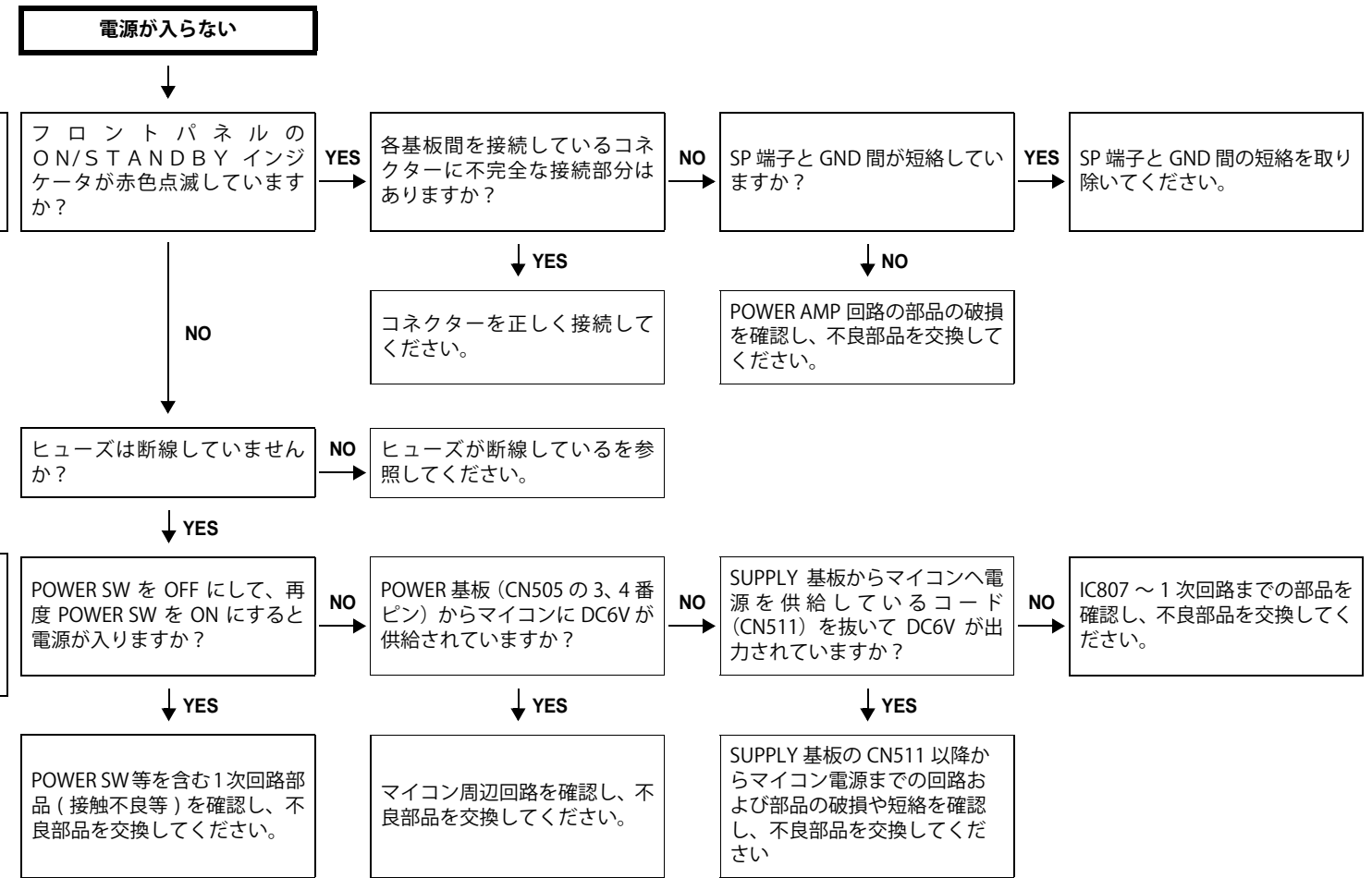

1.2. ヒューズが断線している

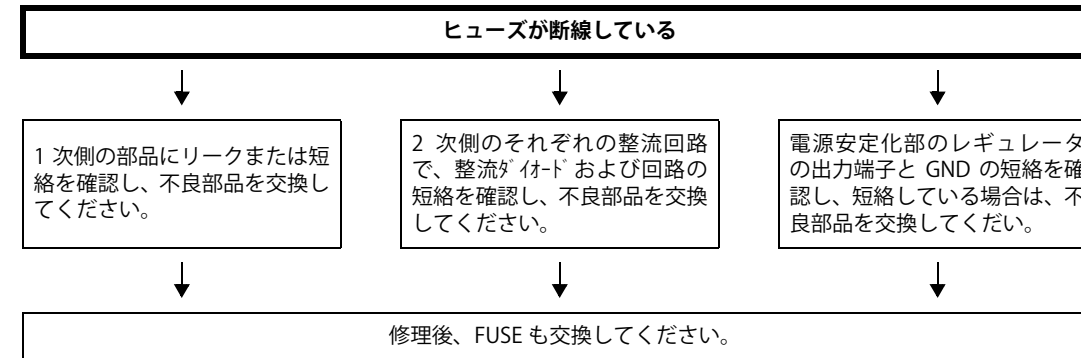

2. Analog video

2.1. MONITOR OUT (CVBS) output NG

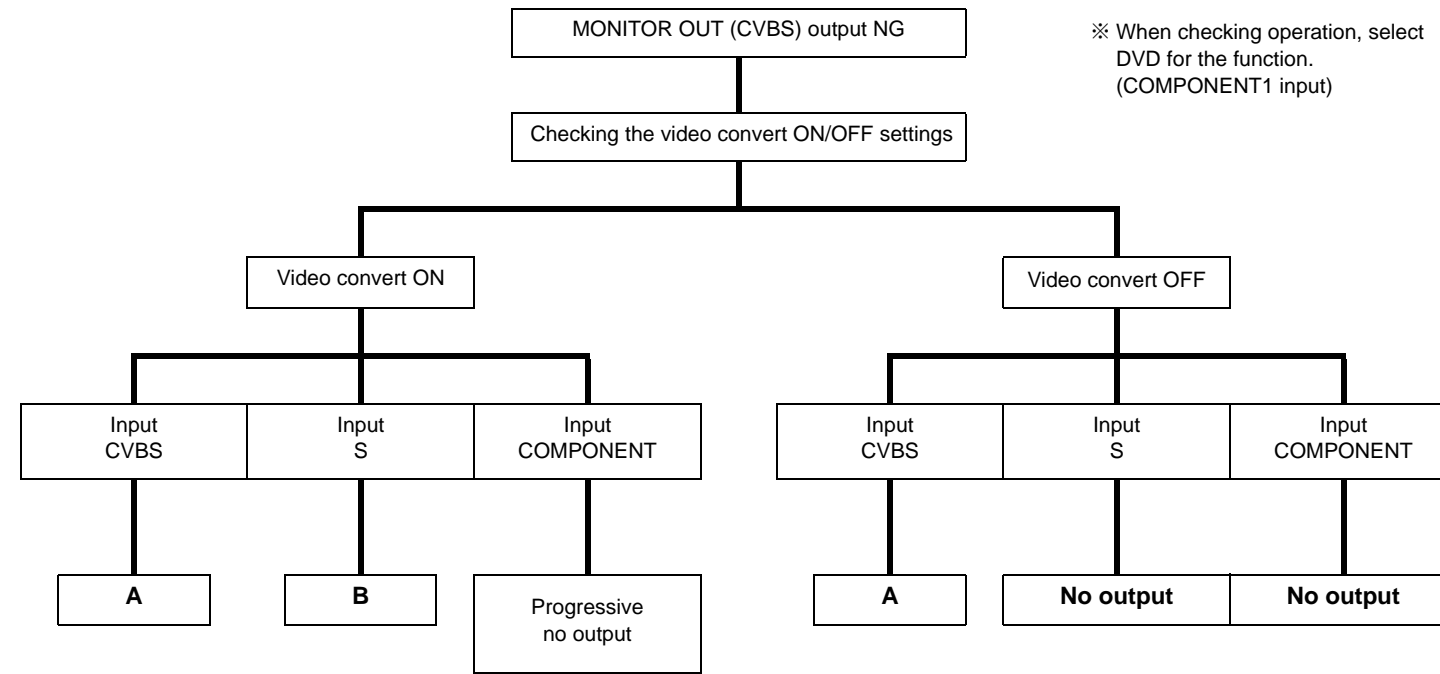

2. アナログビデオ

2.1. MONITOR OUT (CVBS) 出力 NG

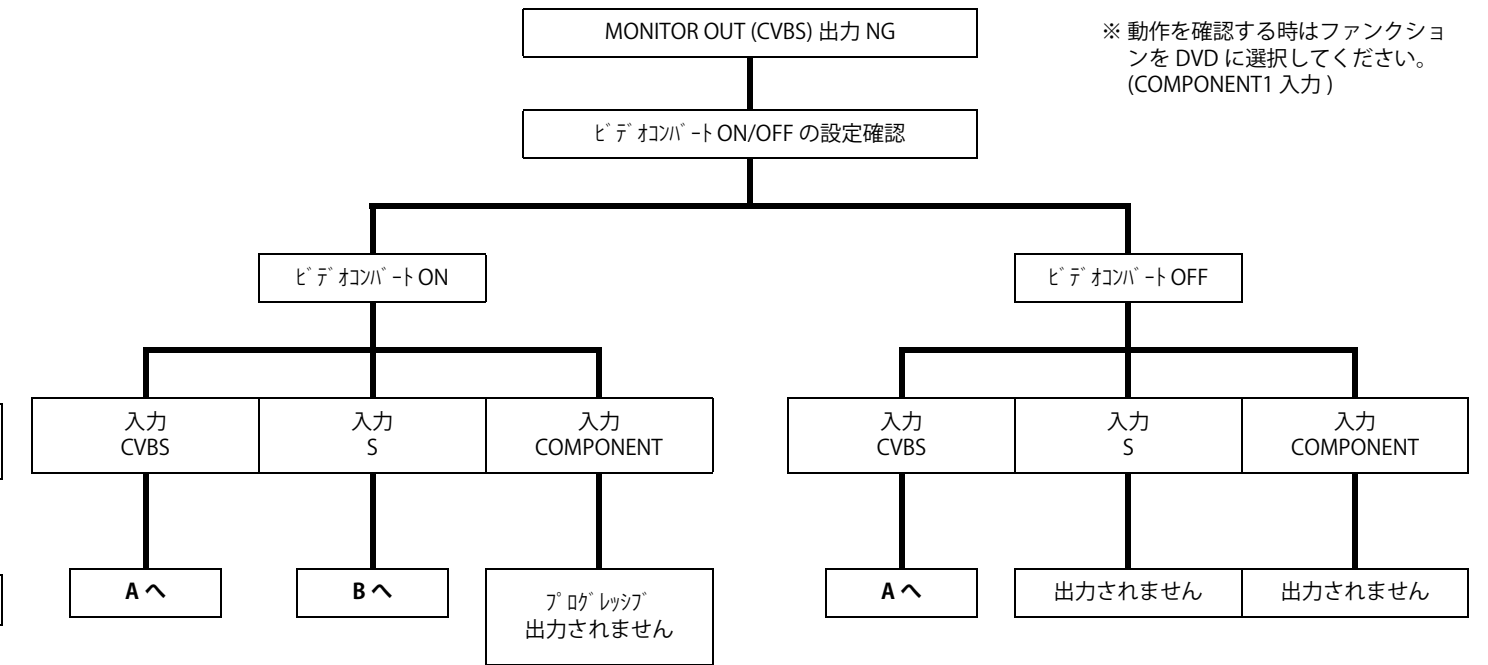

A

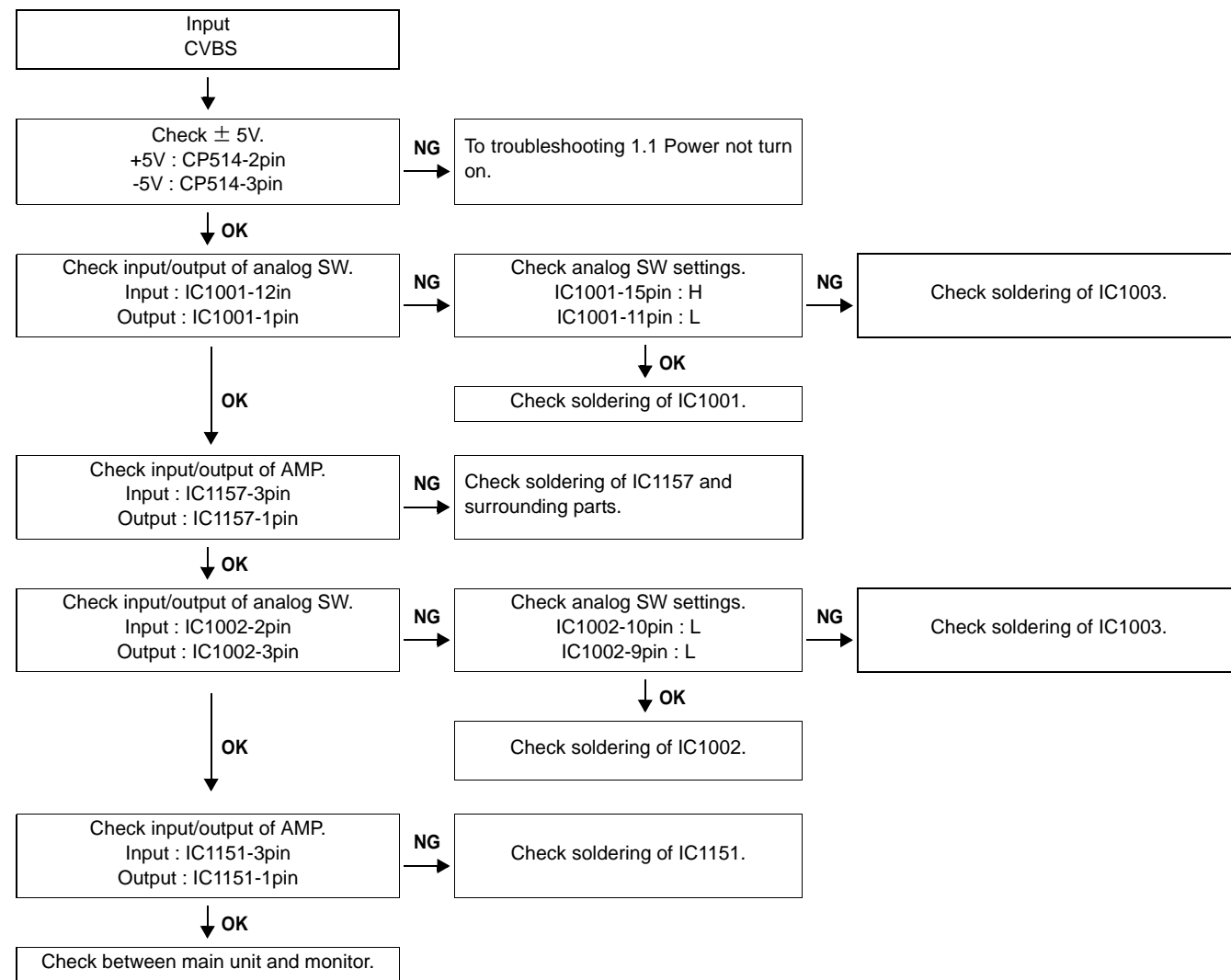

※ Unless specified, VIDEO UNIT part.

A

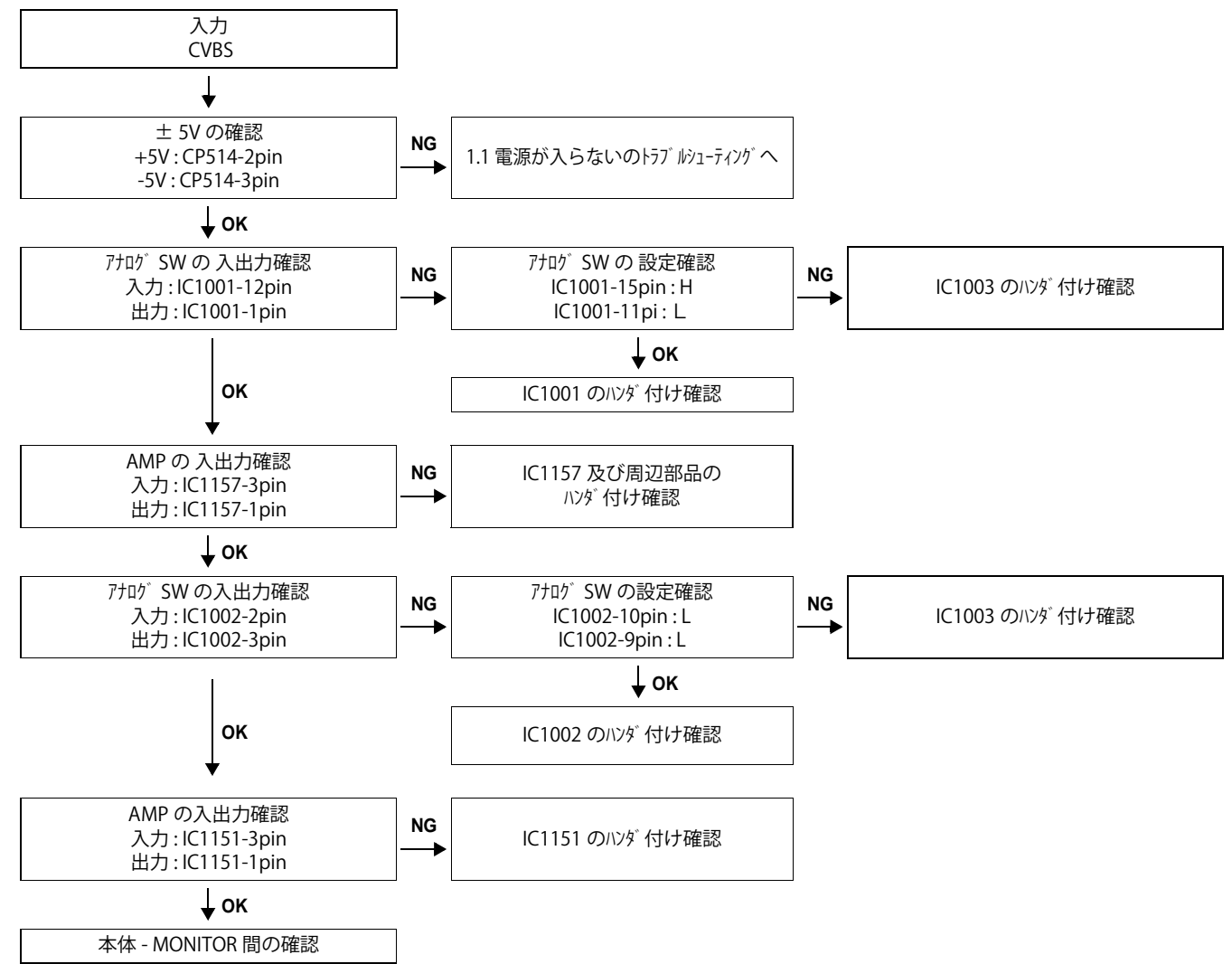

※ 特に記載がない場合は VIDEO 基板の部品です。

B

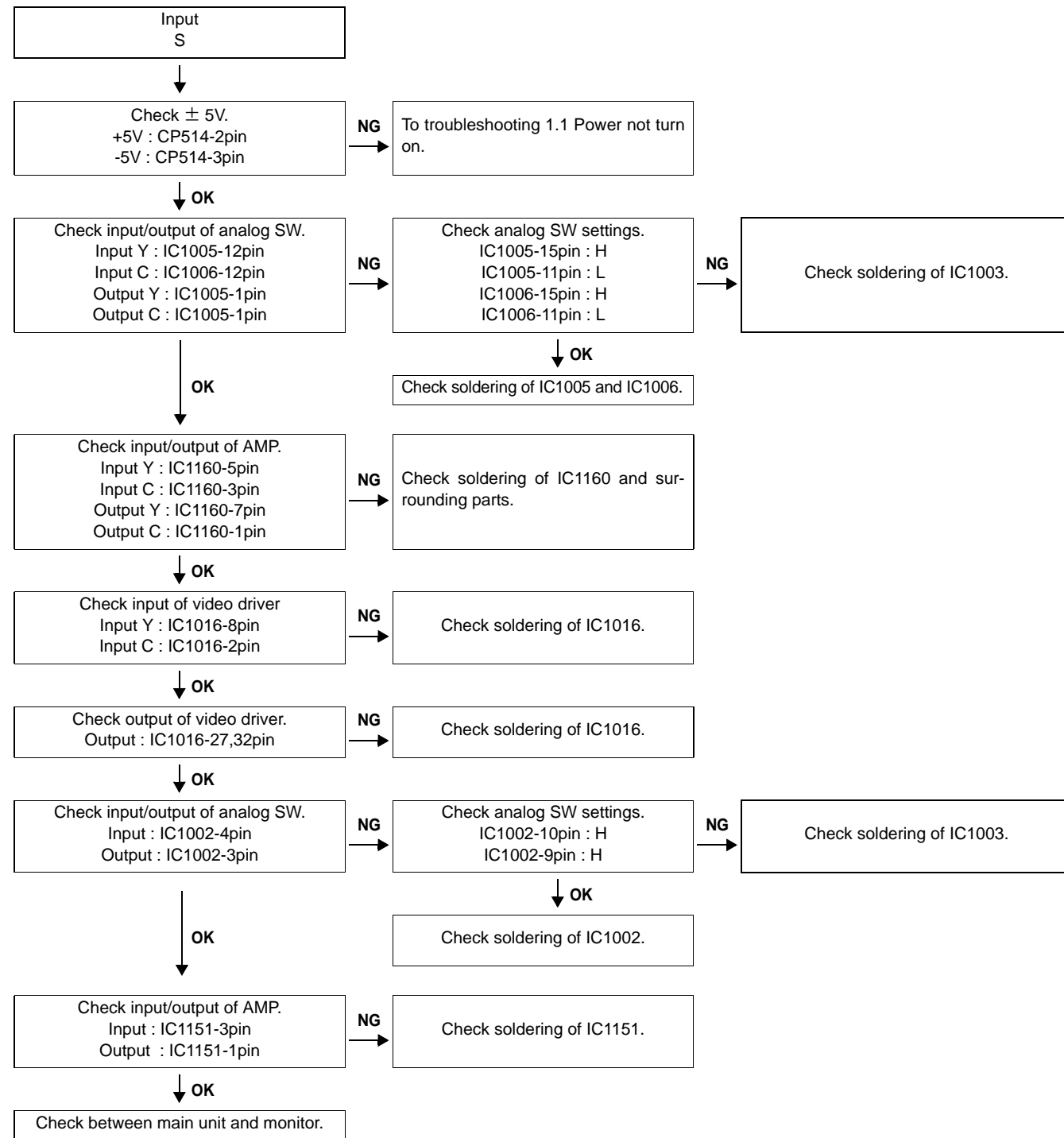

※ Unless specified, VIDEO UNIT part.

B

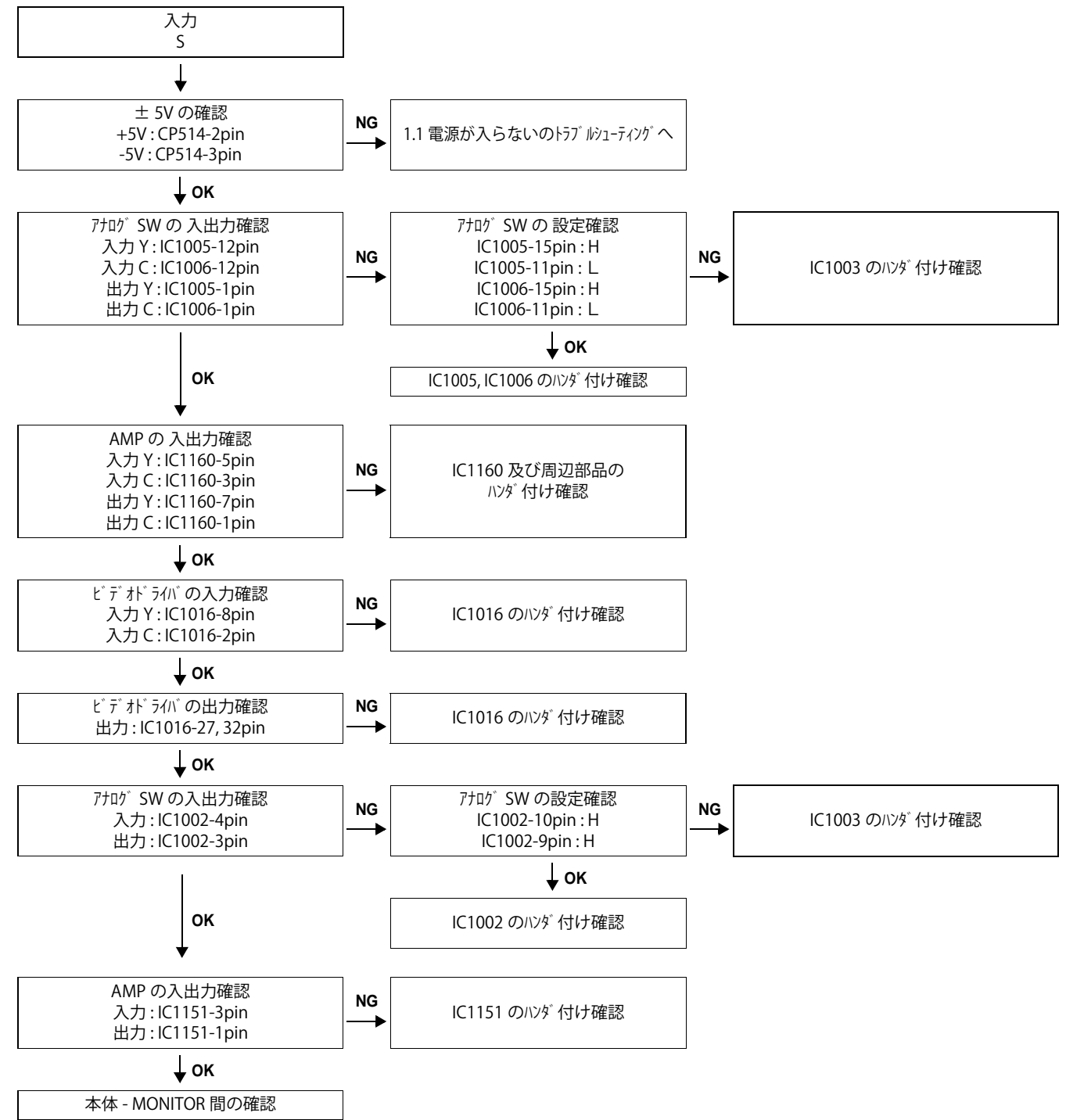

※ 特に記載がない場合は VIDEO 基板の部品です。

2.2. VCR MONITOR OUT(CVBS) Output NG

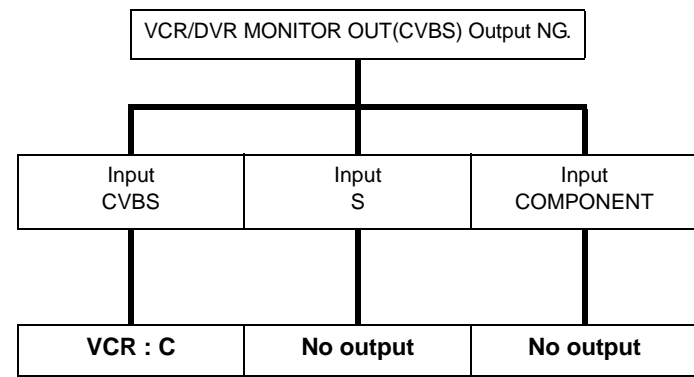

※ When checking operation, select DVD for the function.

2.2. VCR MONITOR OUT(CVBS) 出力 NG

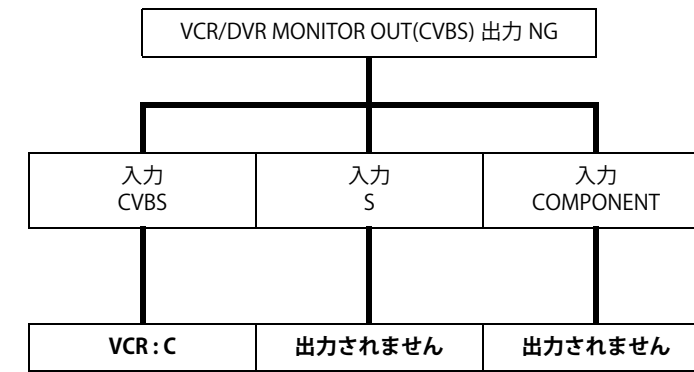

※ 動作を確認する時はファンクションを DVD に選択してください。

C

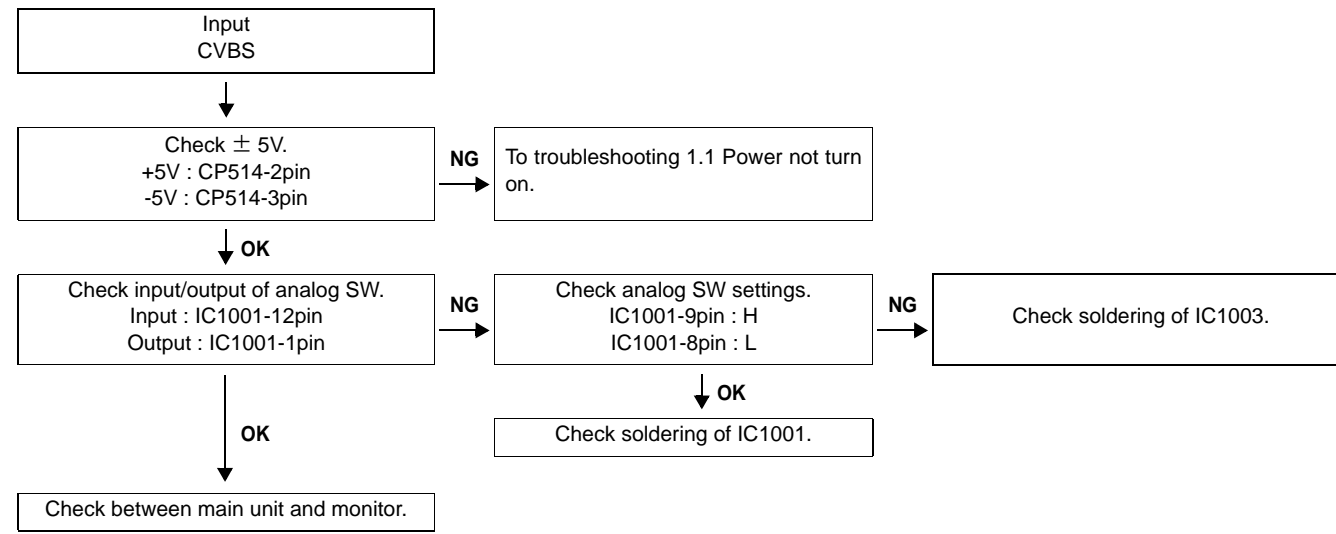

※ Unless specified, VIDEO UNIT part.

C

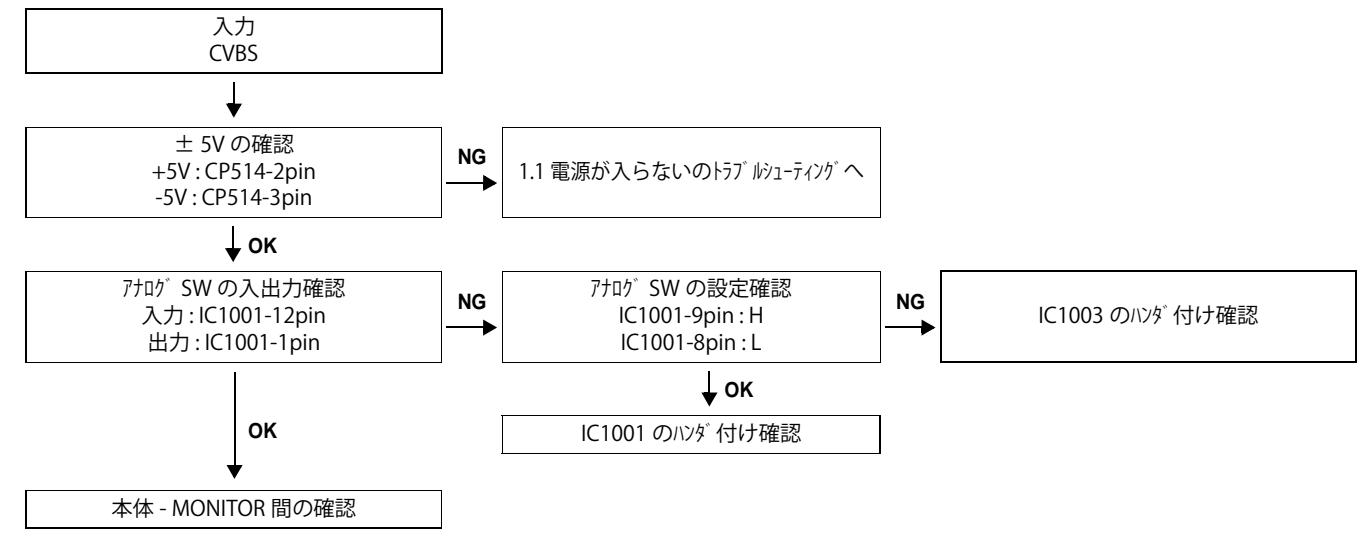

※ 特に記載がない場合は VIDEO 基板の部品です。

2.3. MONITOR OUT (S) Output NG

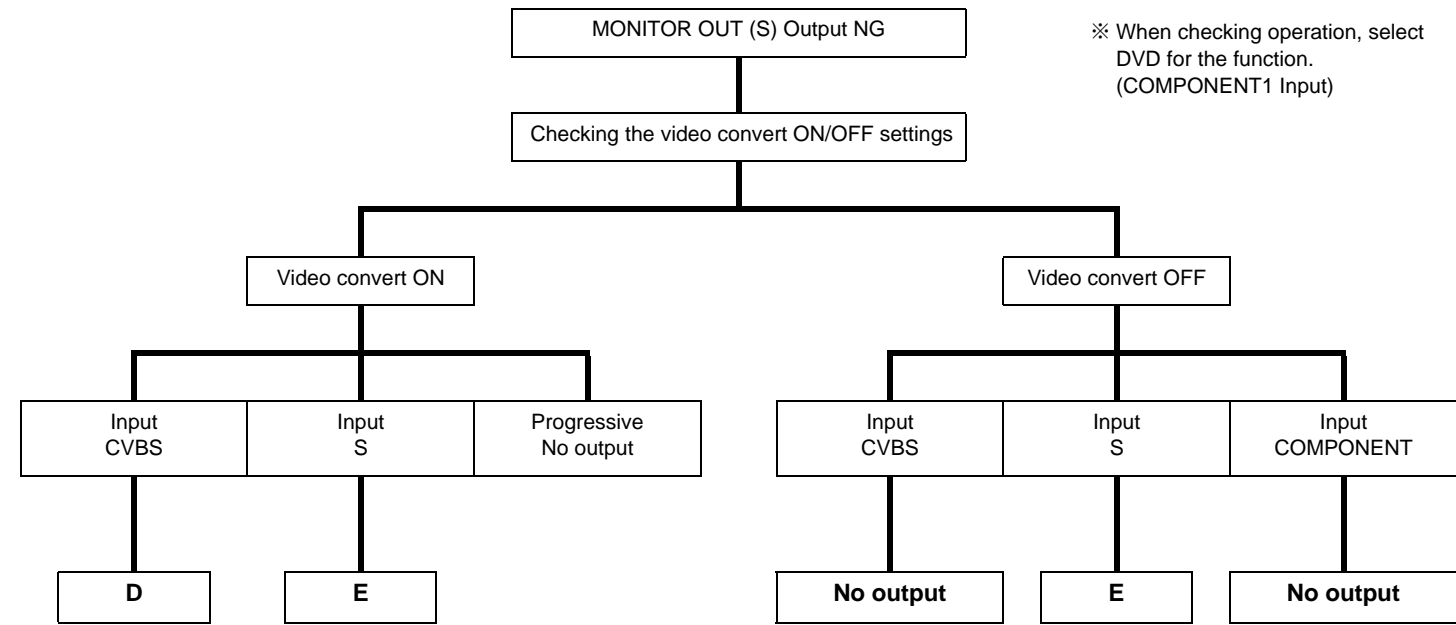

2.3. MONITOR OUT (S) 出力 NG

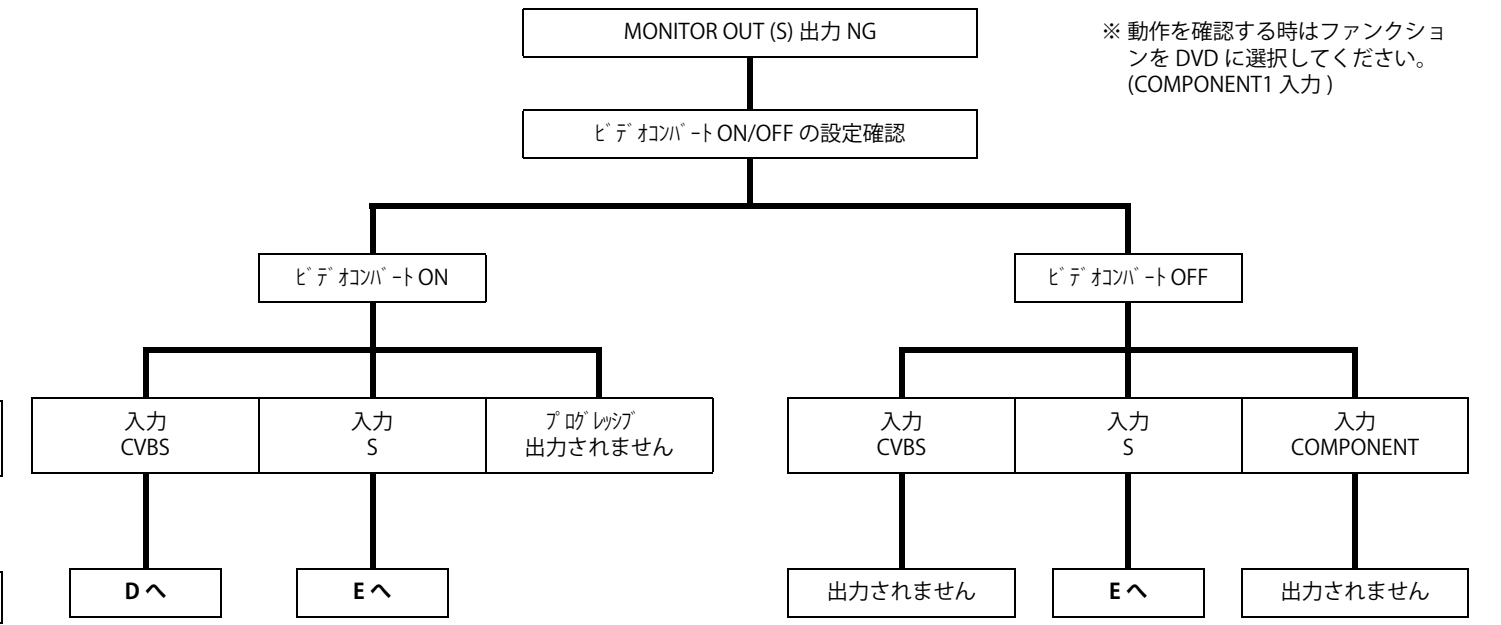

D

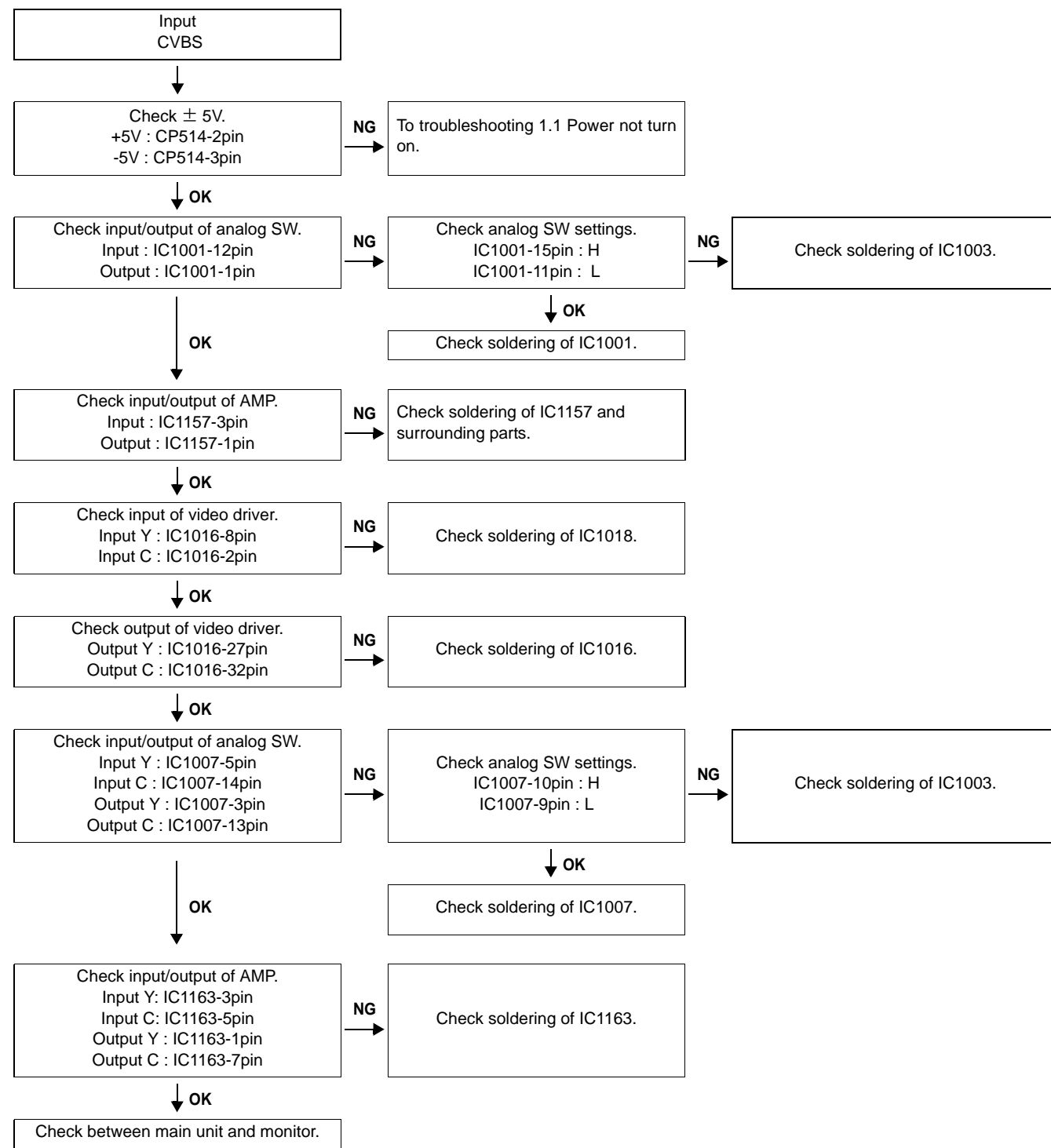

※ Unless specified, VIDEO UNIT part.

D

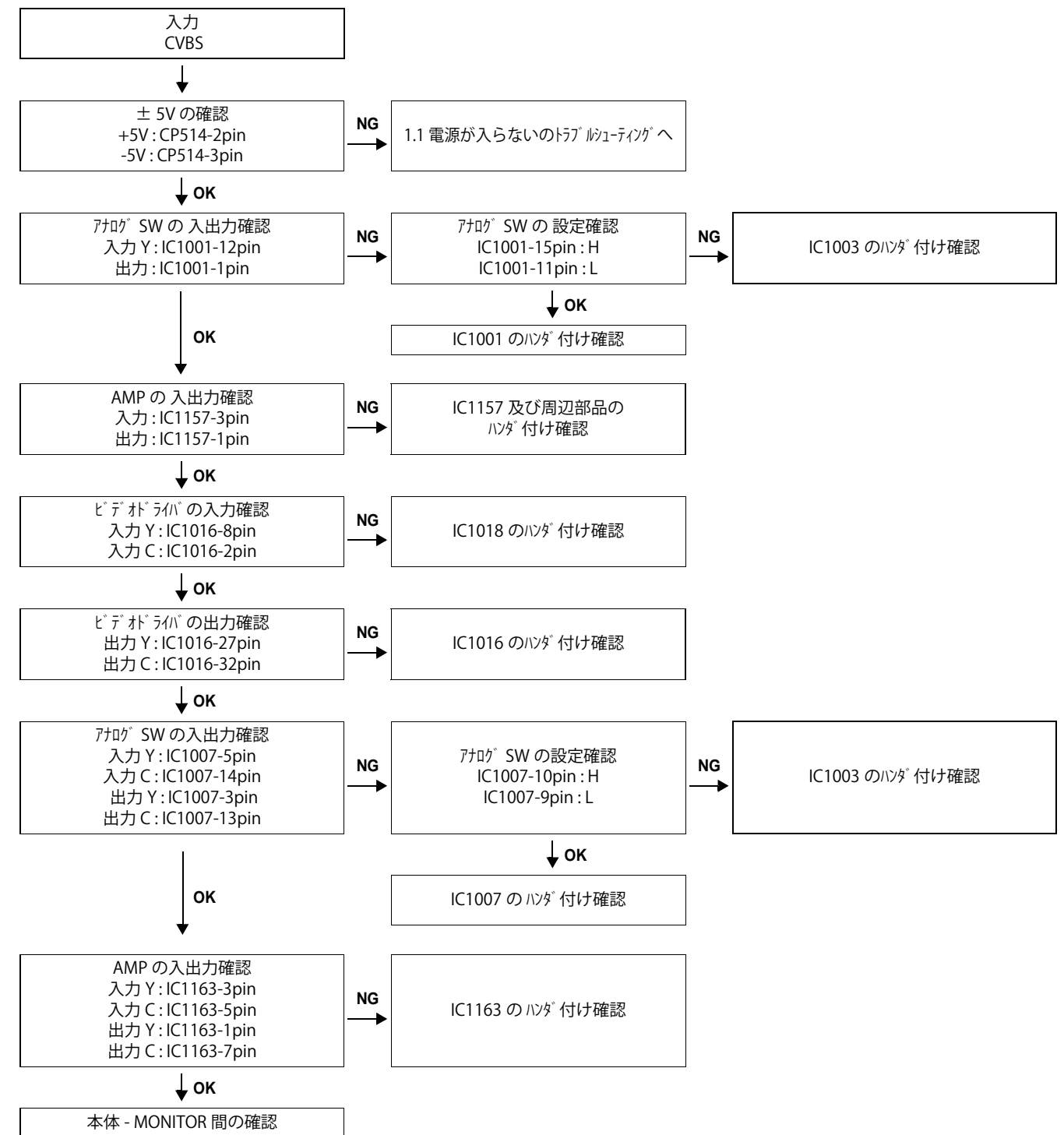

※ 特に記載がない場合は VIDEO 基板の部品です。

E

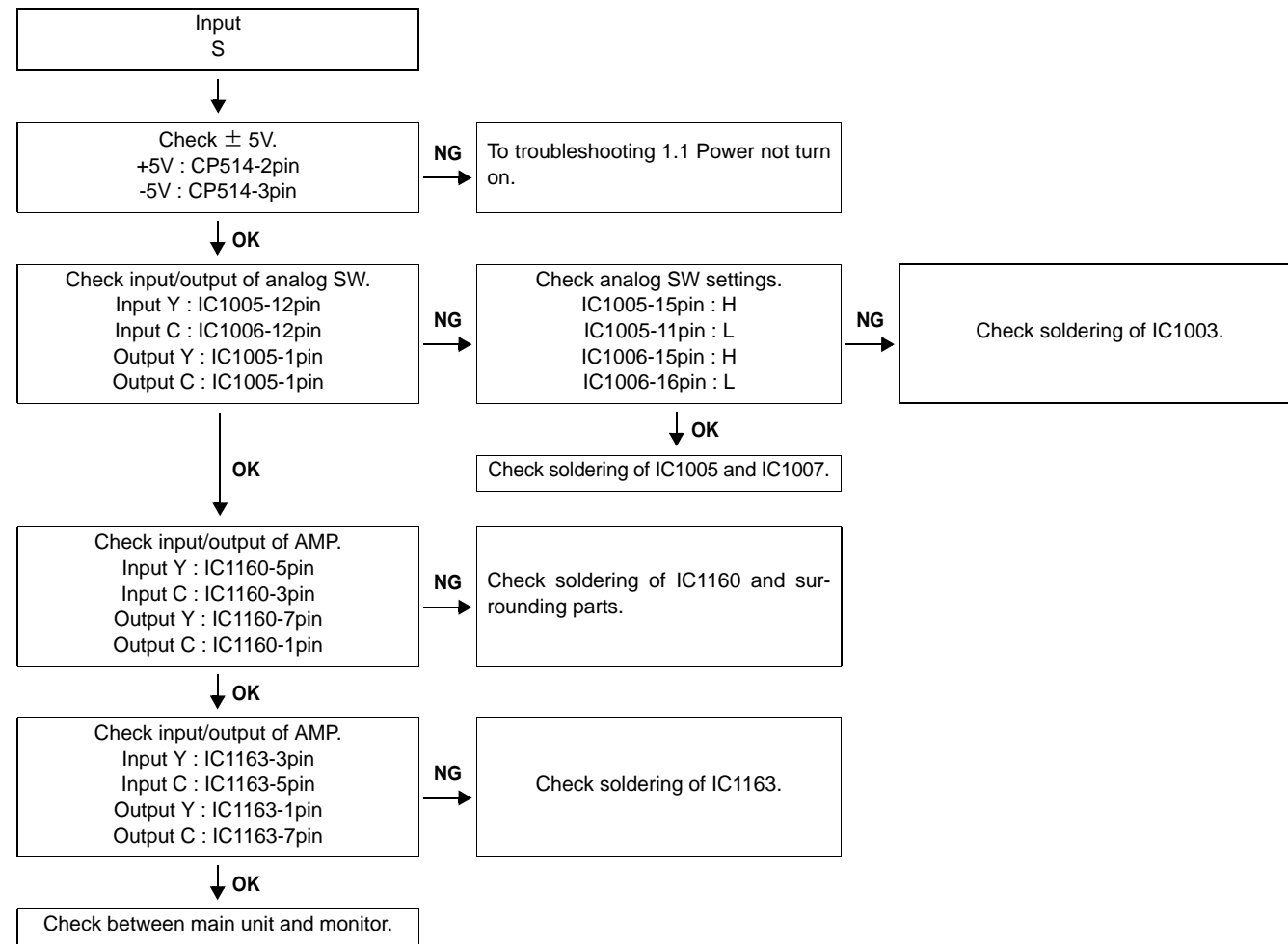

※ Unless specified, VIDEO UNIT part.

E

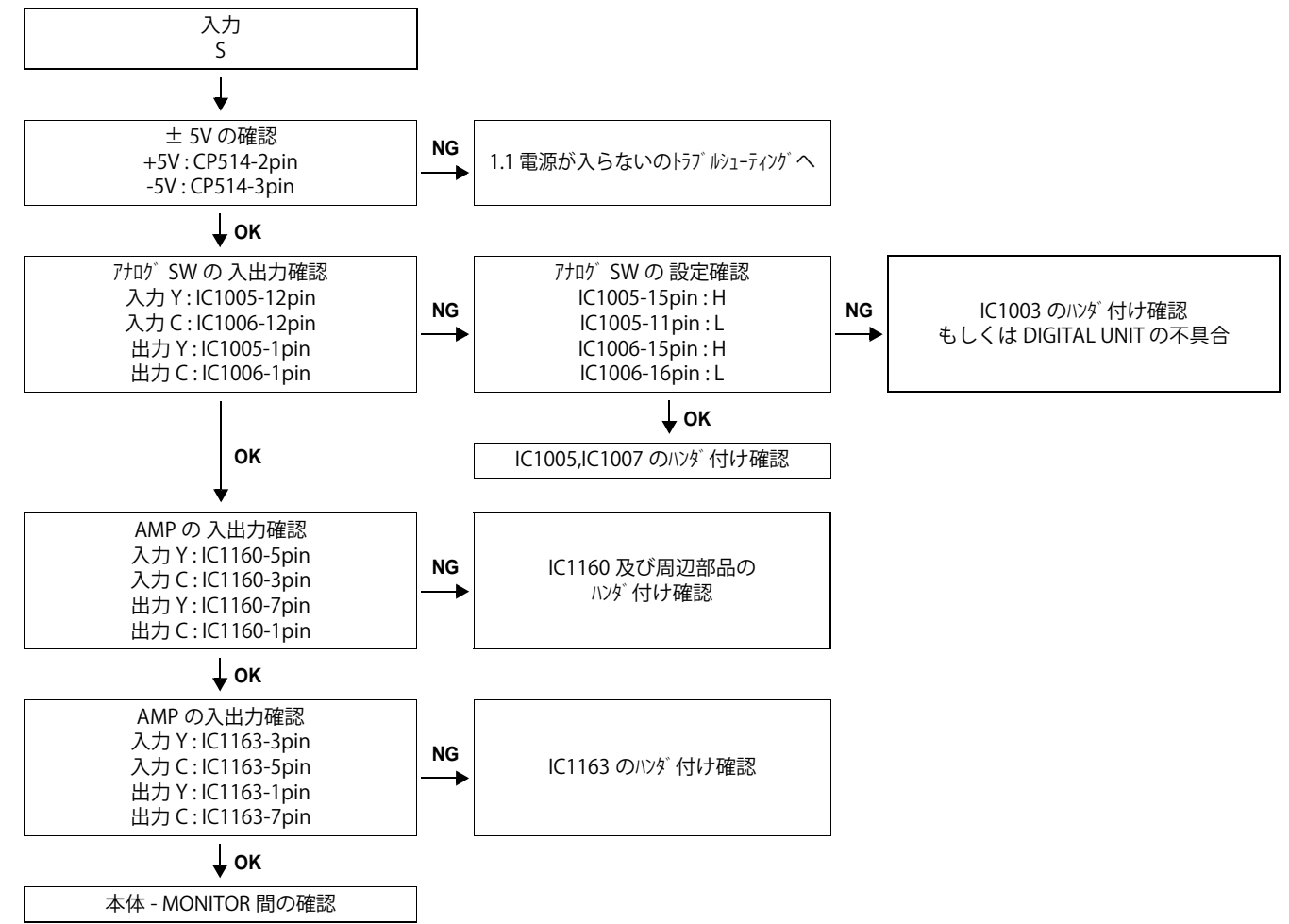

※ 特に記載がない場合は VIDEO 基板の部品です。

2.4. VCR MONITOR OUT(S) Output NG

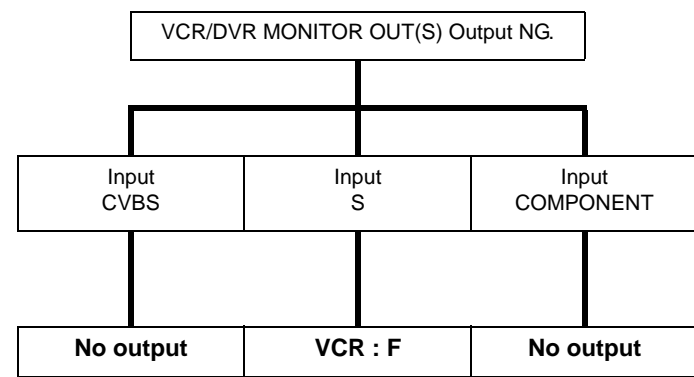

※ When checking operation, select DVD for the function.

2.4. VCR MONITOR OUT(S) 出力 NG

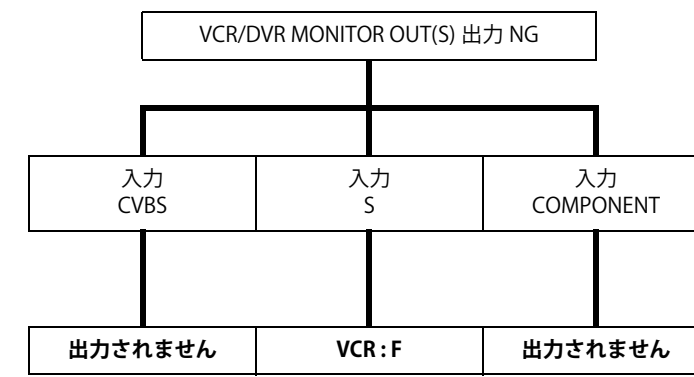

※ 動作を確認する時はファンクションを DVD に選択してください。

F

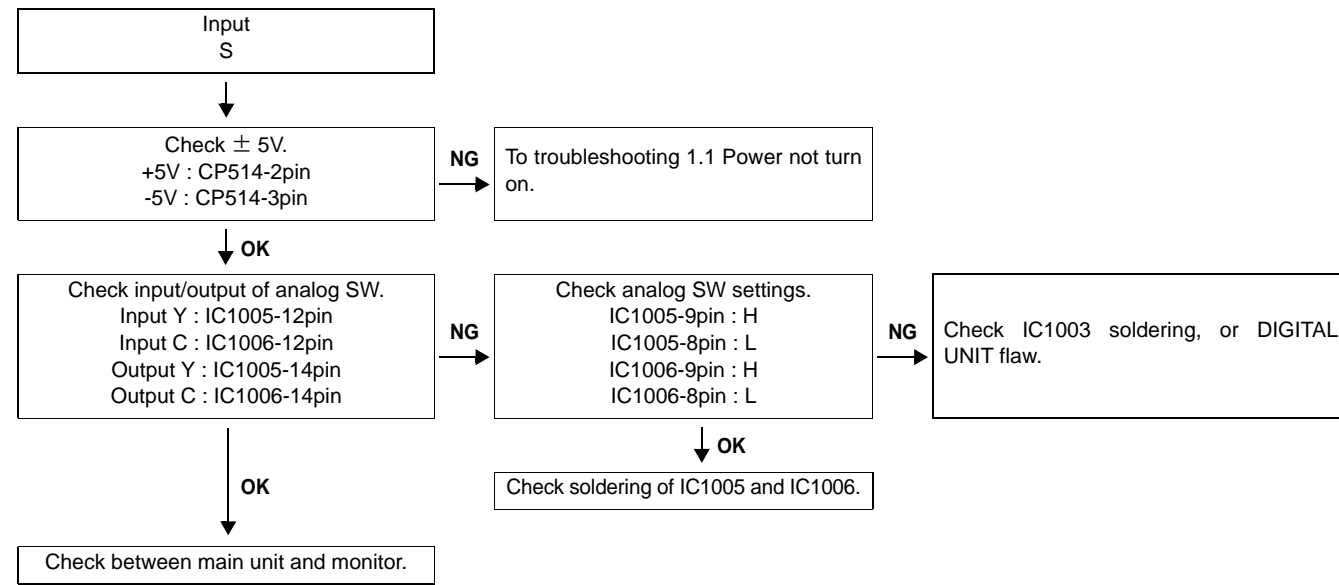

※ Unless specified, VIDEO UNIT part.

F

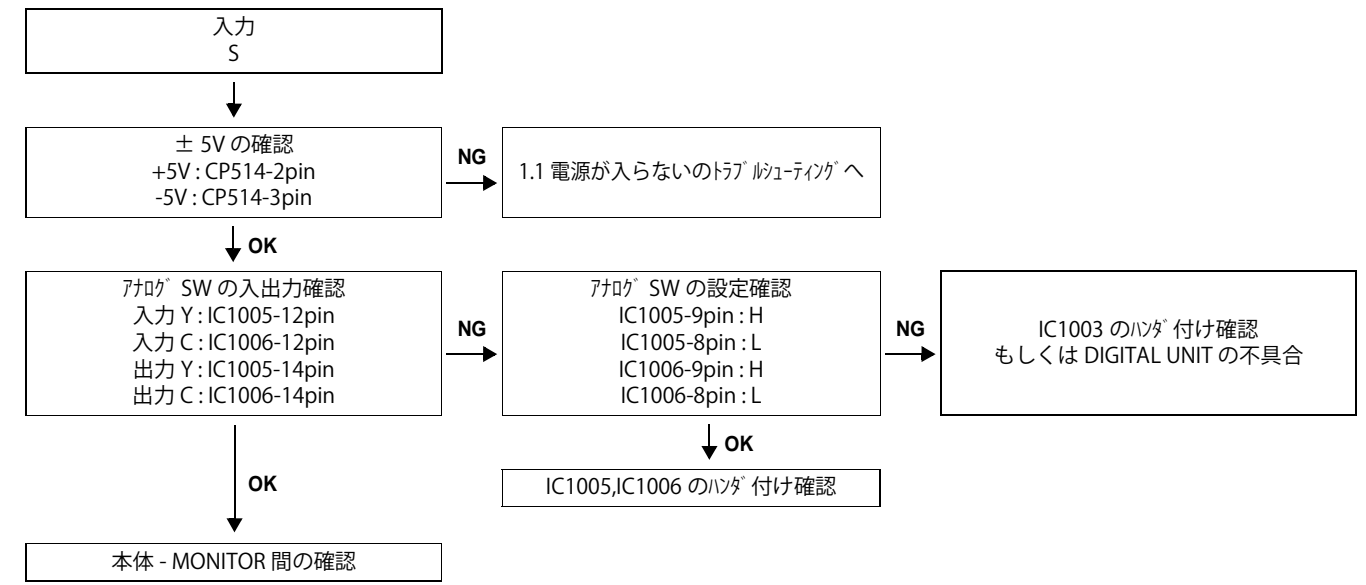

※ 特に記載がない場合は VIDEO 基板の部品です。

2.5. COMPONENT OUT 1,2 Output NG

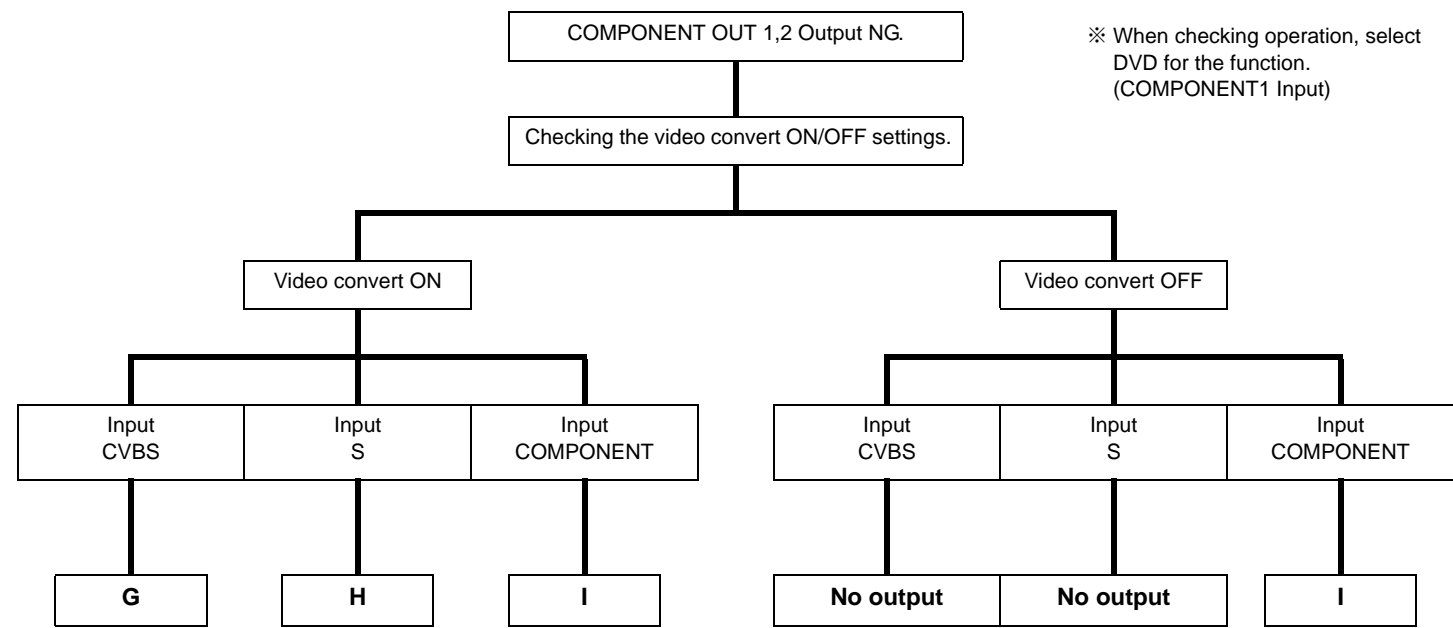

2.5. COMPONENT OUT 1,2 出力 NG

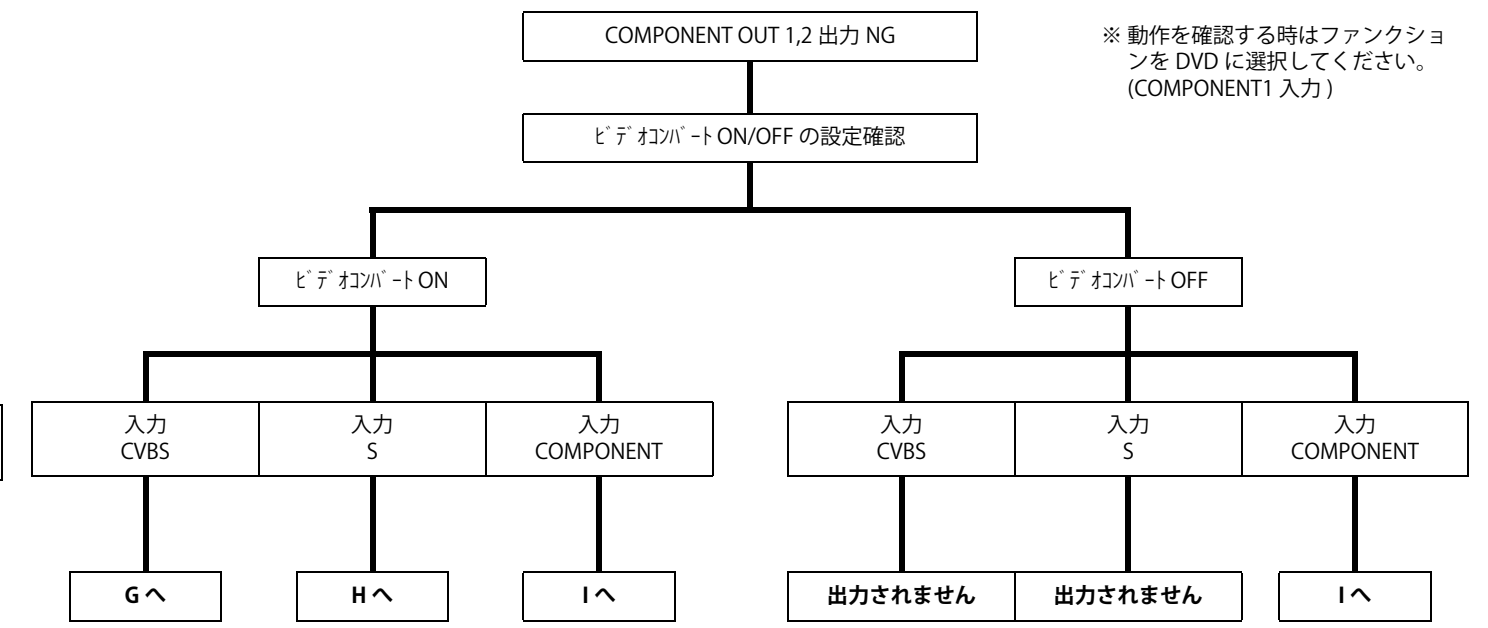

G

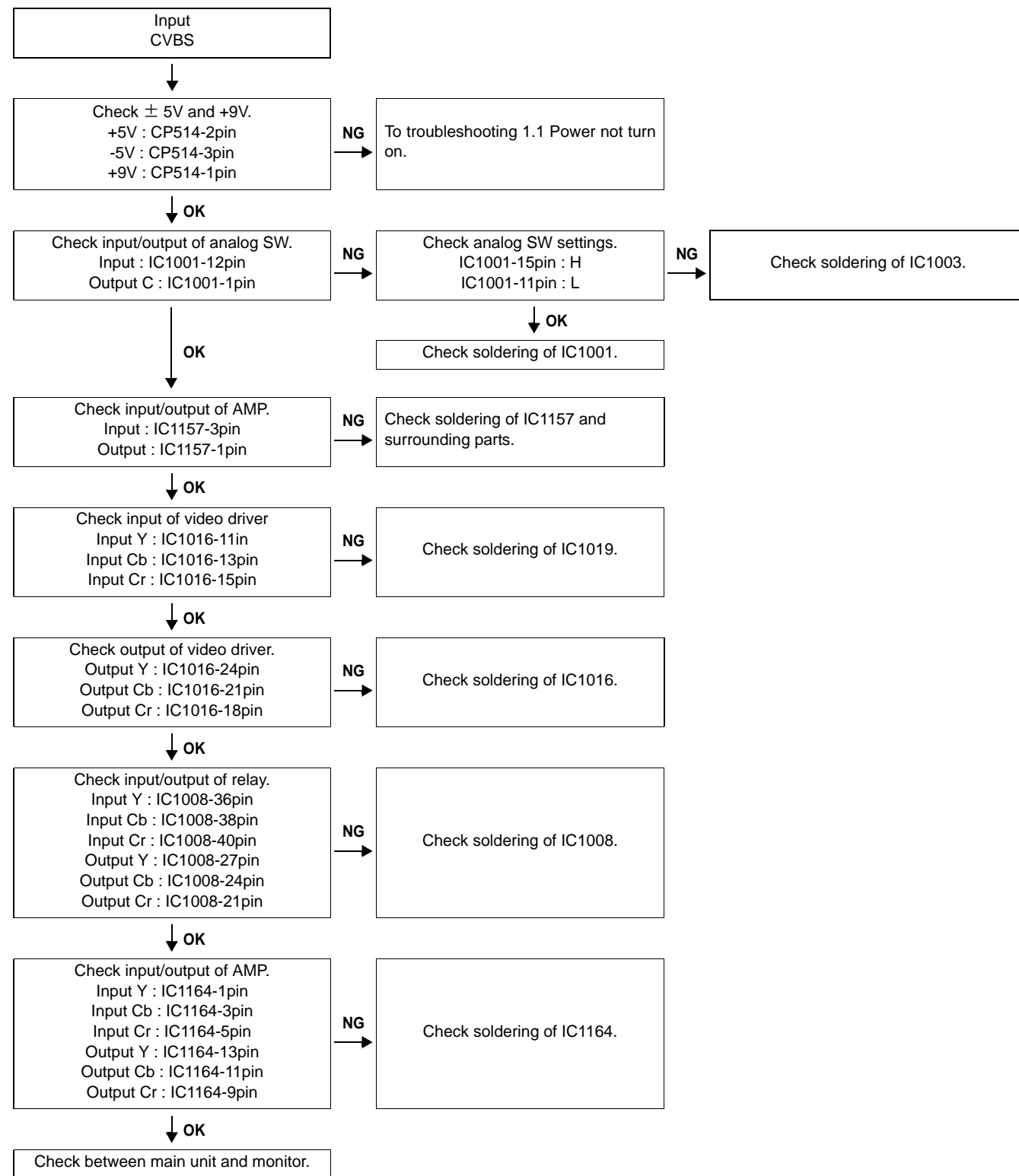

※ Unless specified, VIDEO UNIT part.

G

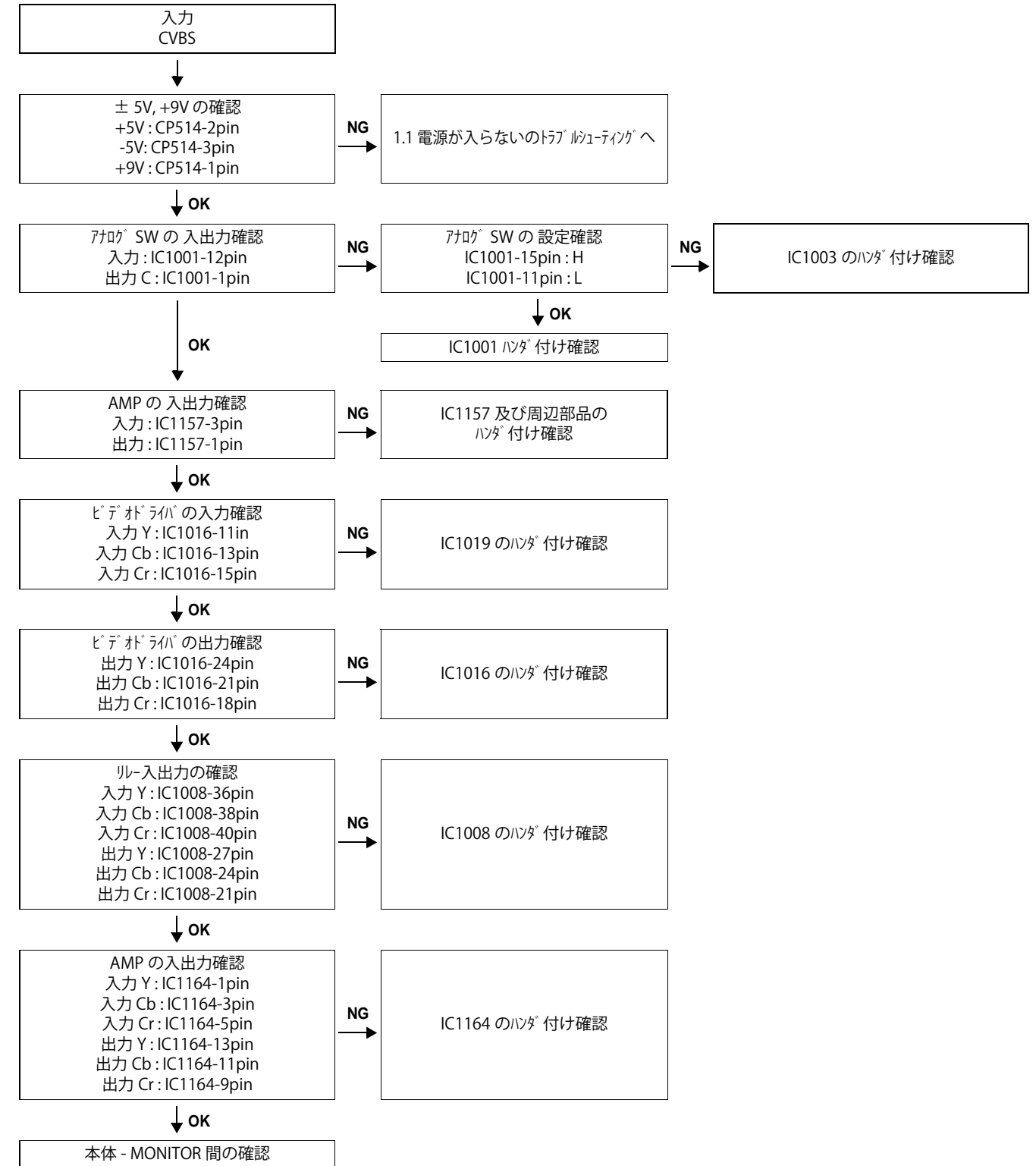

※ 特に記載がない場合は VIDEO 基板の部品です。

H

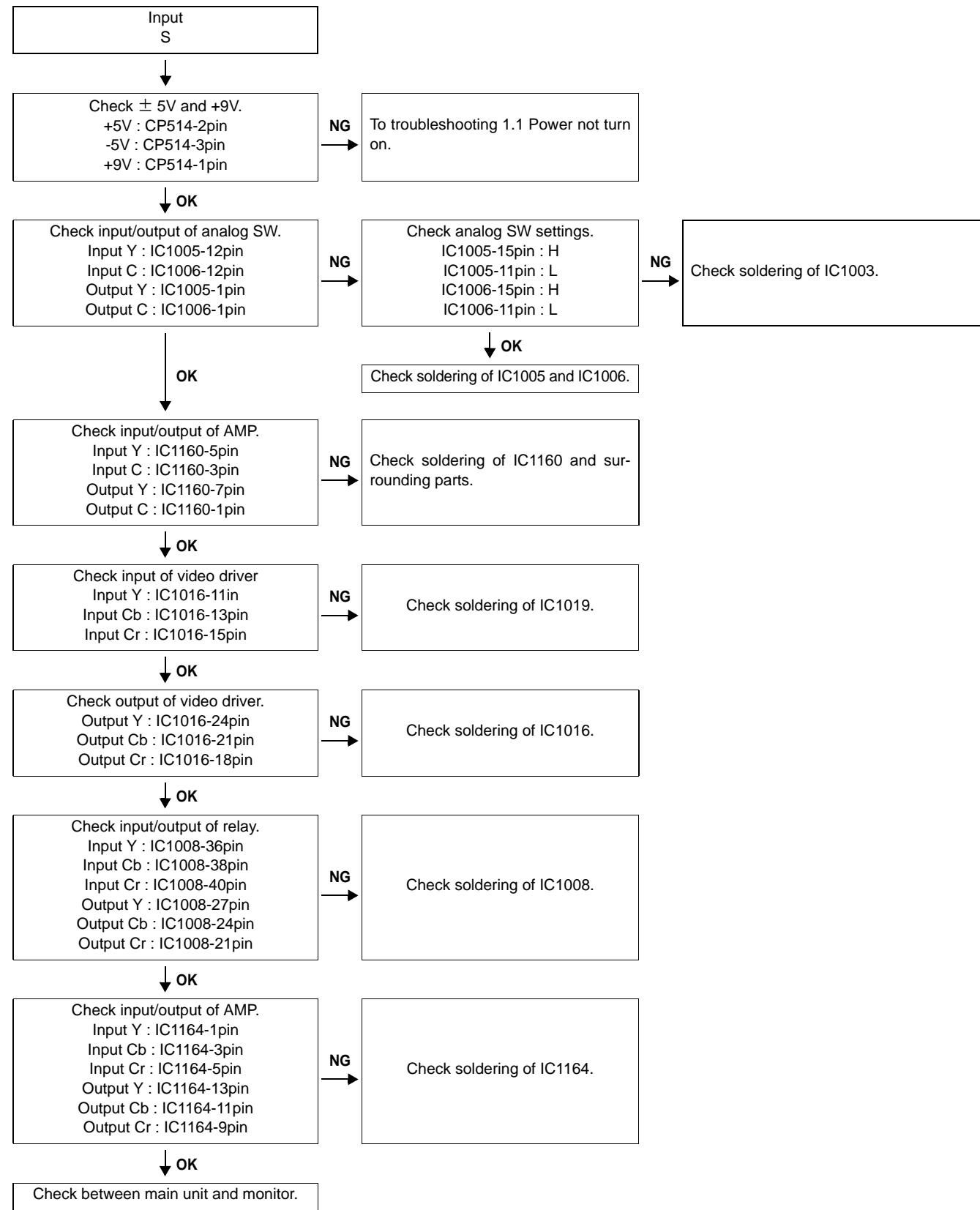

※ Unless specified, VIDEO UNIT part.

H

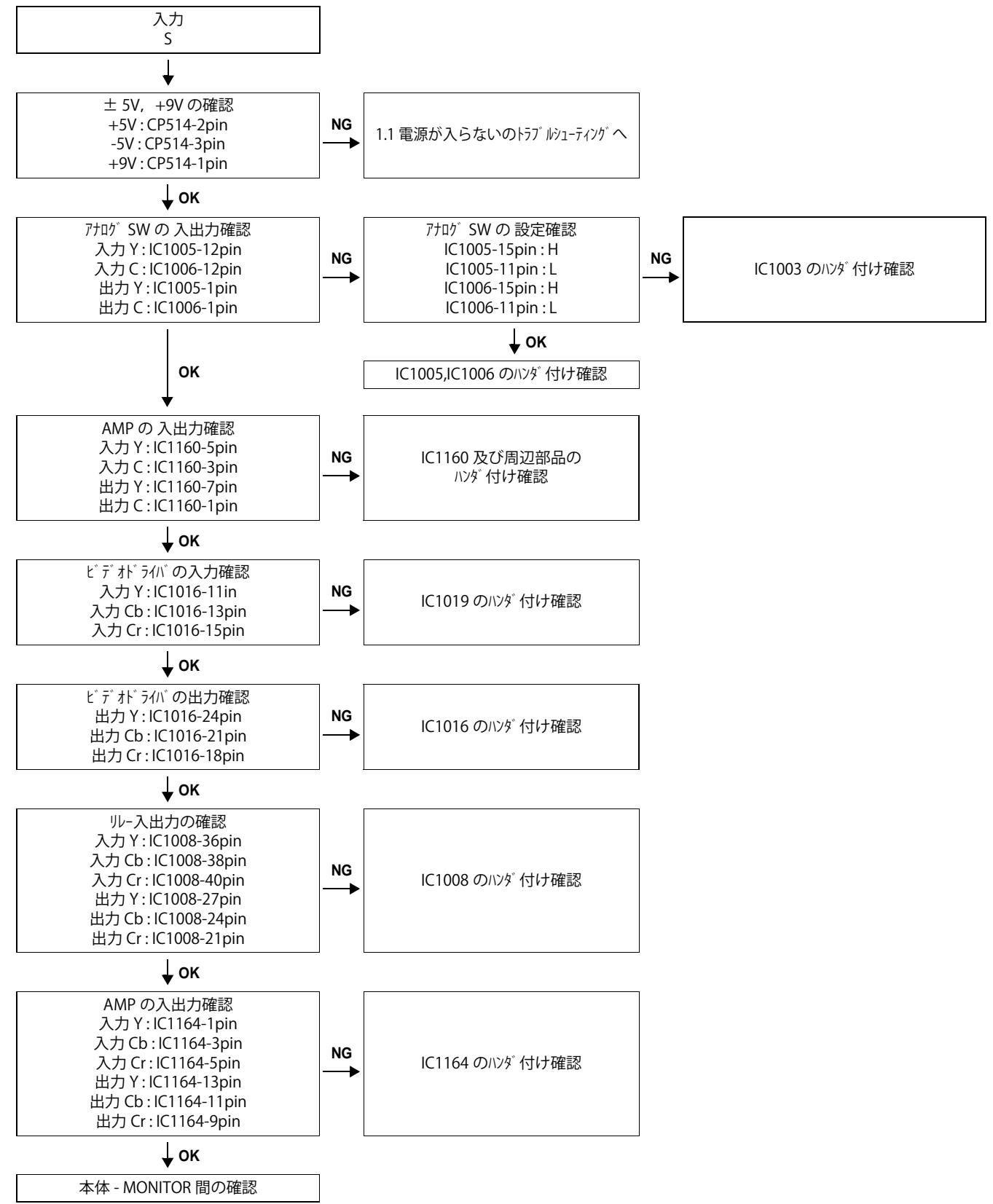

※ 特に記載がない場合は VIDEO 基板の部品です。

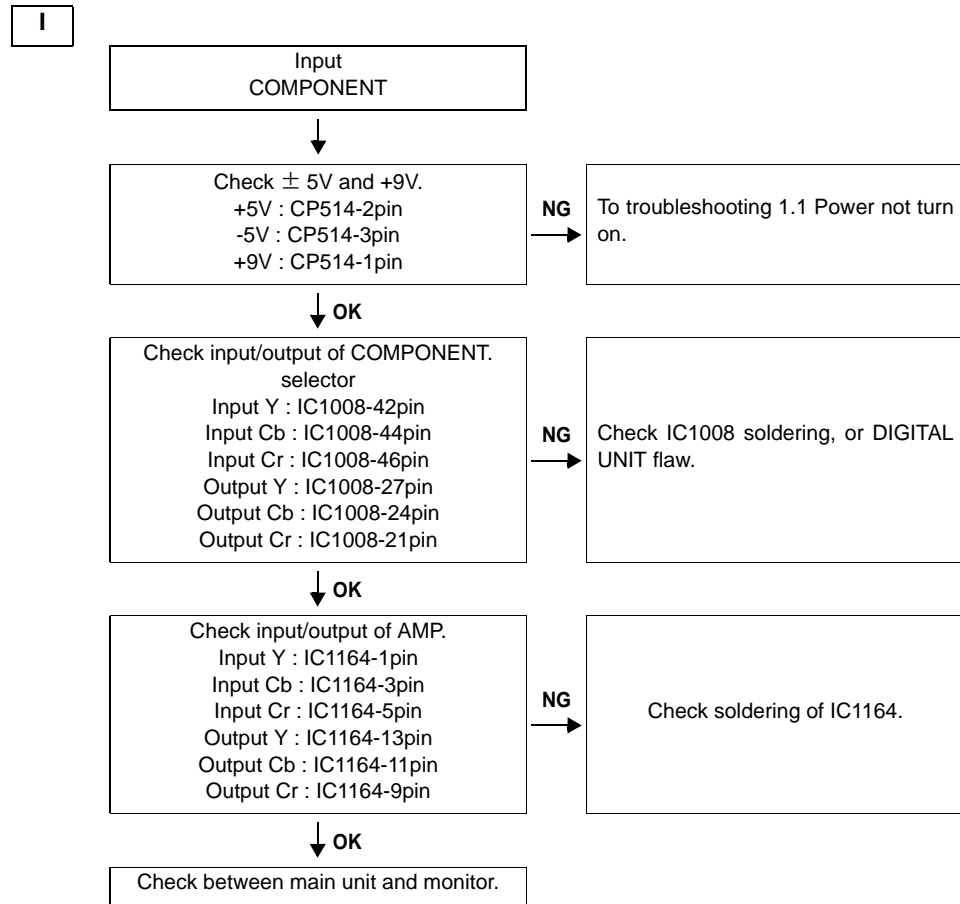

※ Unless specified, VIDEO UNIT part.

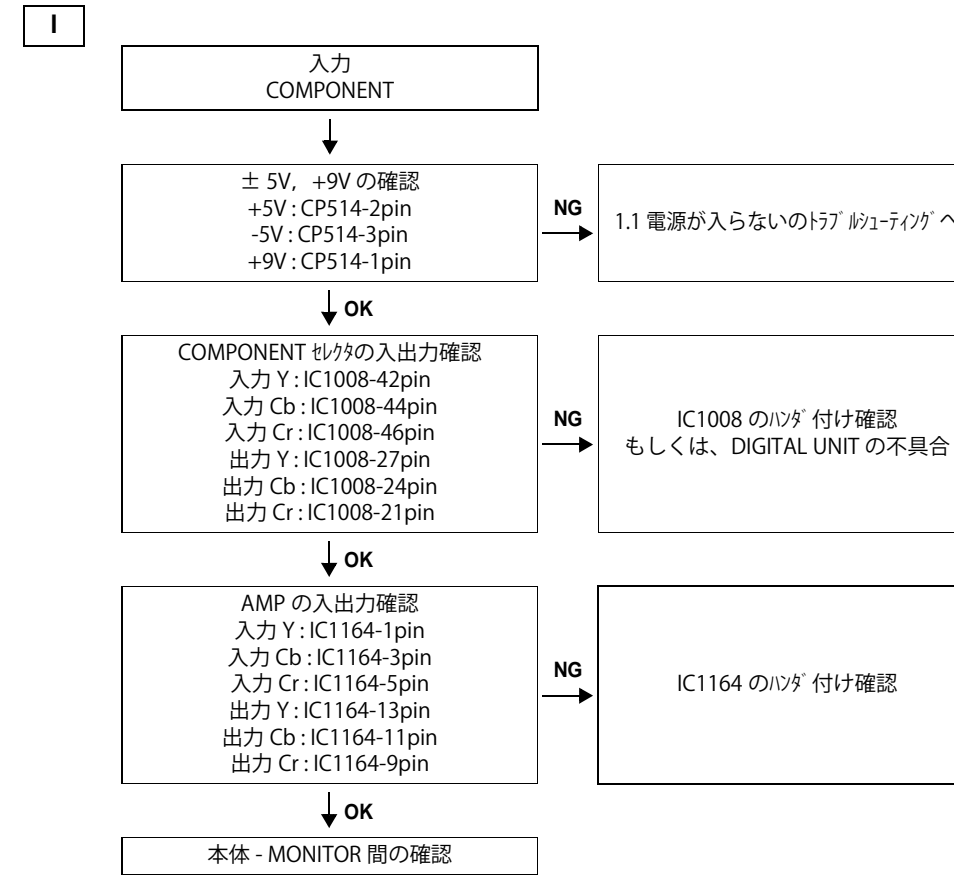

※ 特に記載がない場合は VIDEO 基板の部品です。

2.6. HDMI OUT 1,2 Output NG

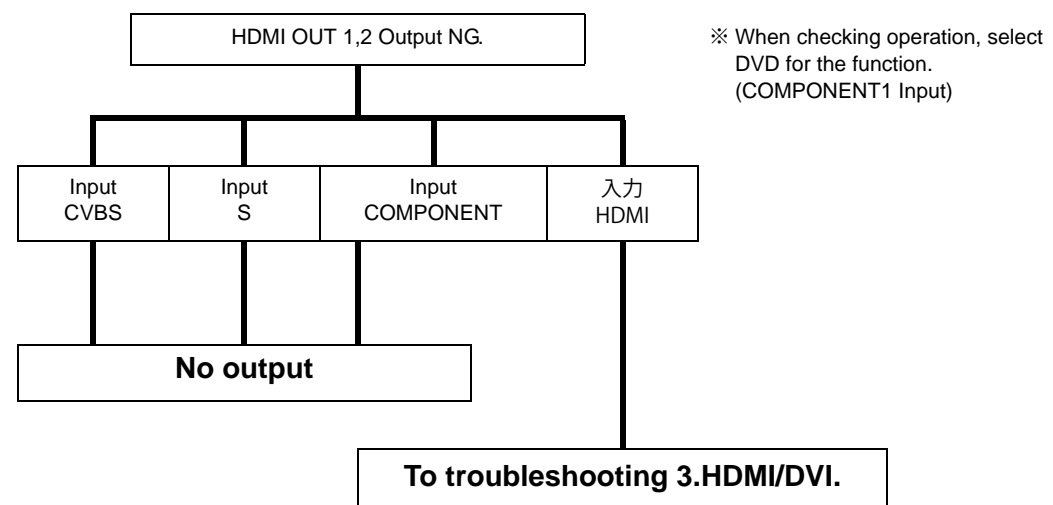

2.6. HDMI OUT 1,2 出力 NG

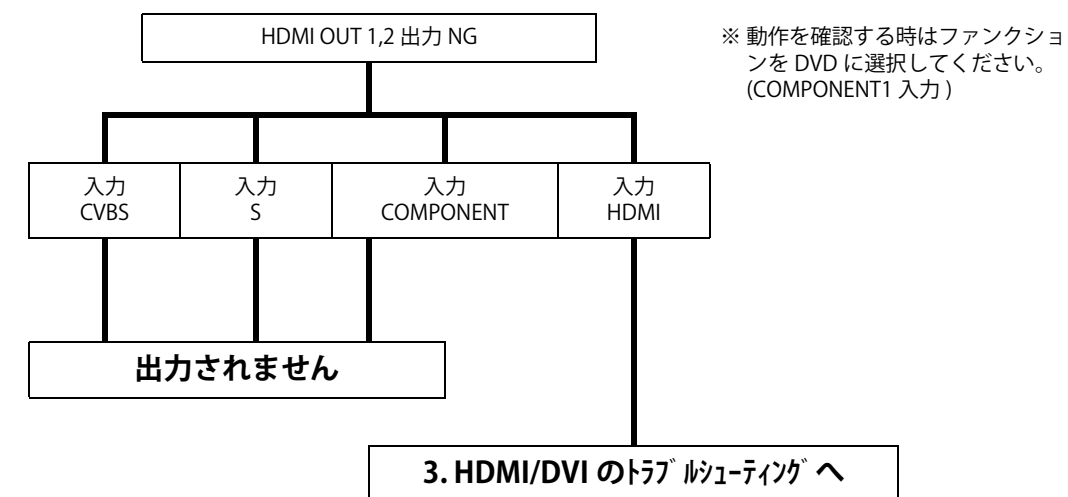

3. HDMI/DVI

3.1. No picture or sound is output

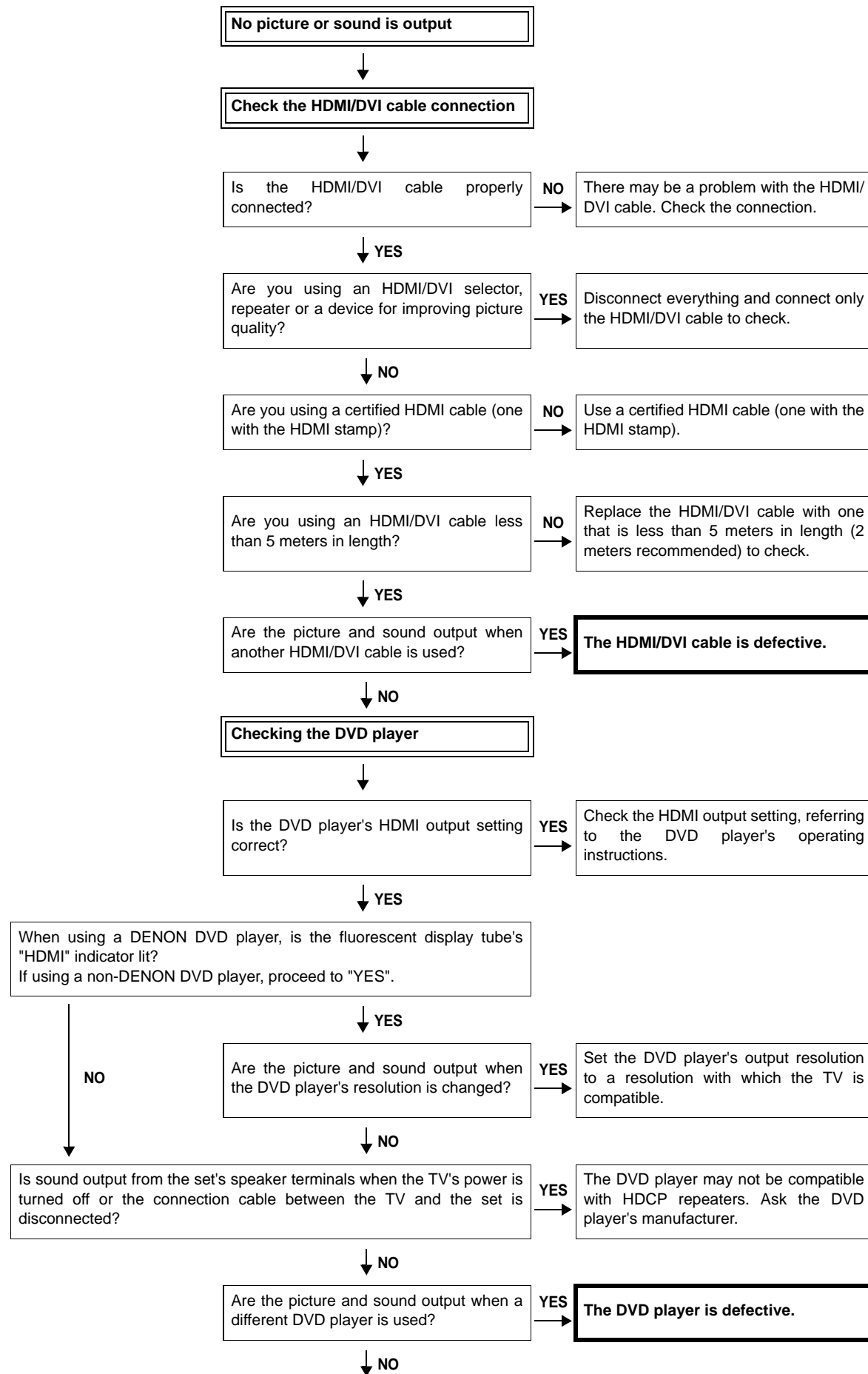

3. HDMI/DVI

3.1. 映像と音声出力されない

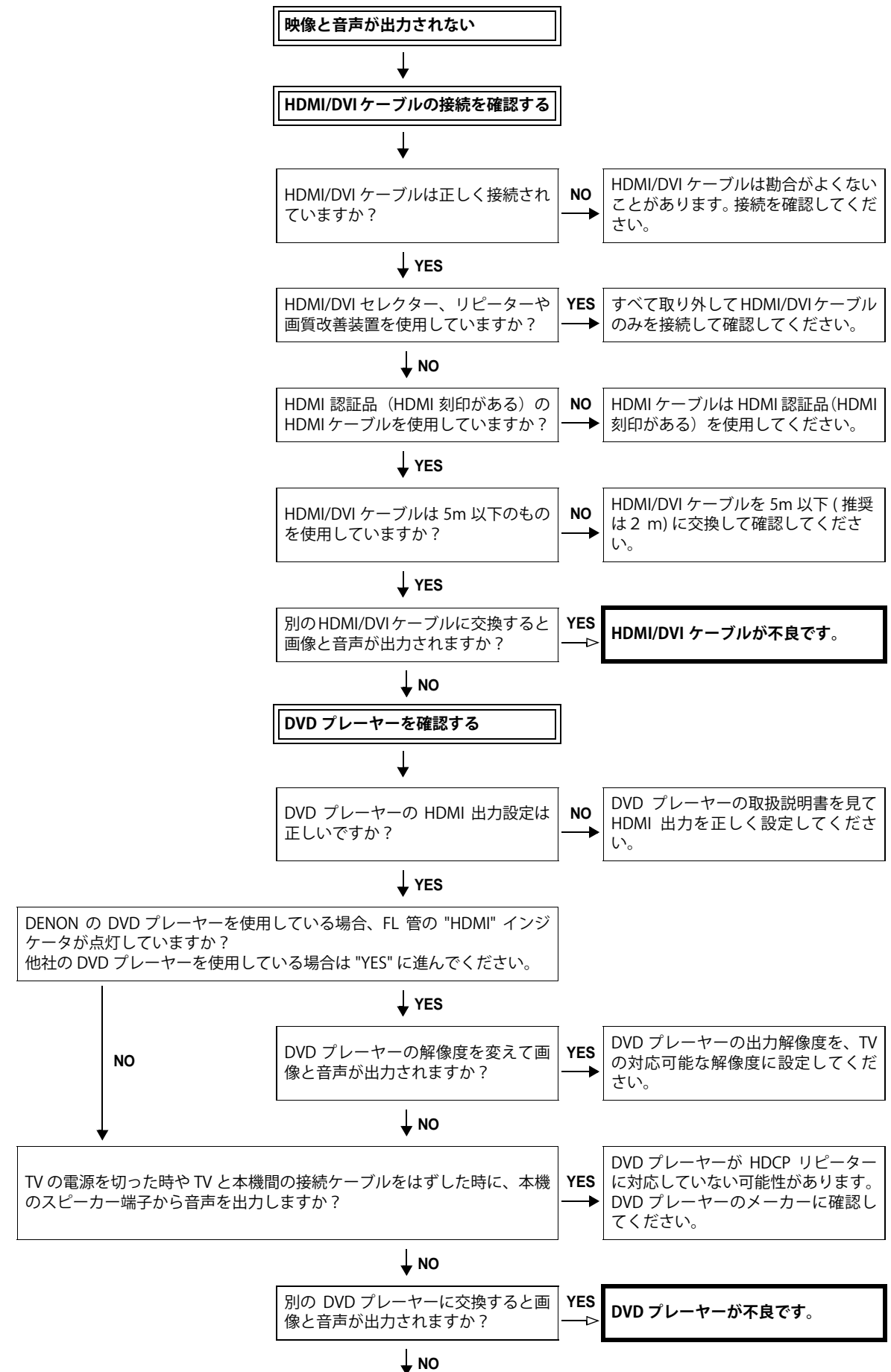

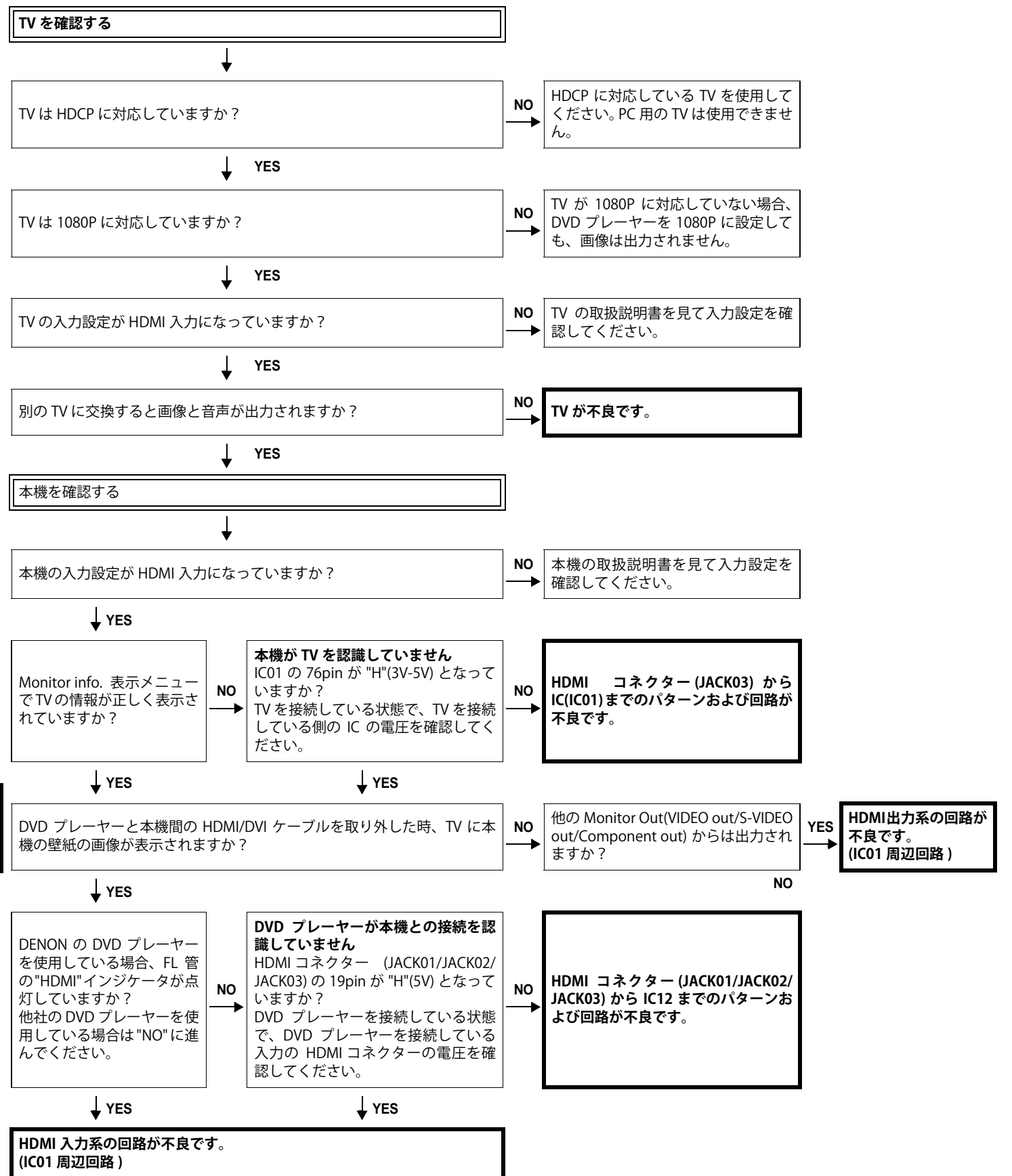
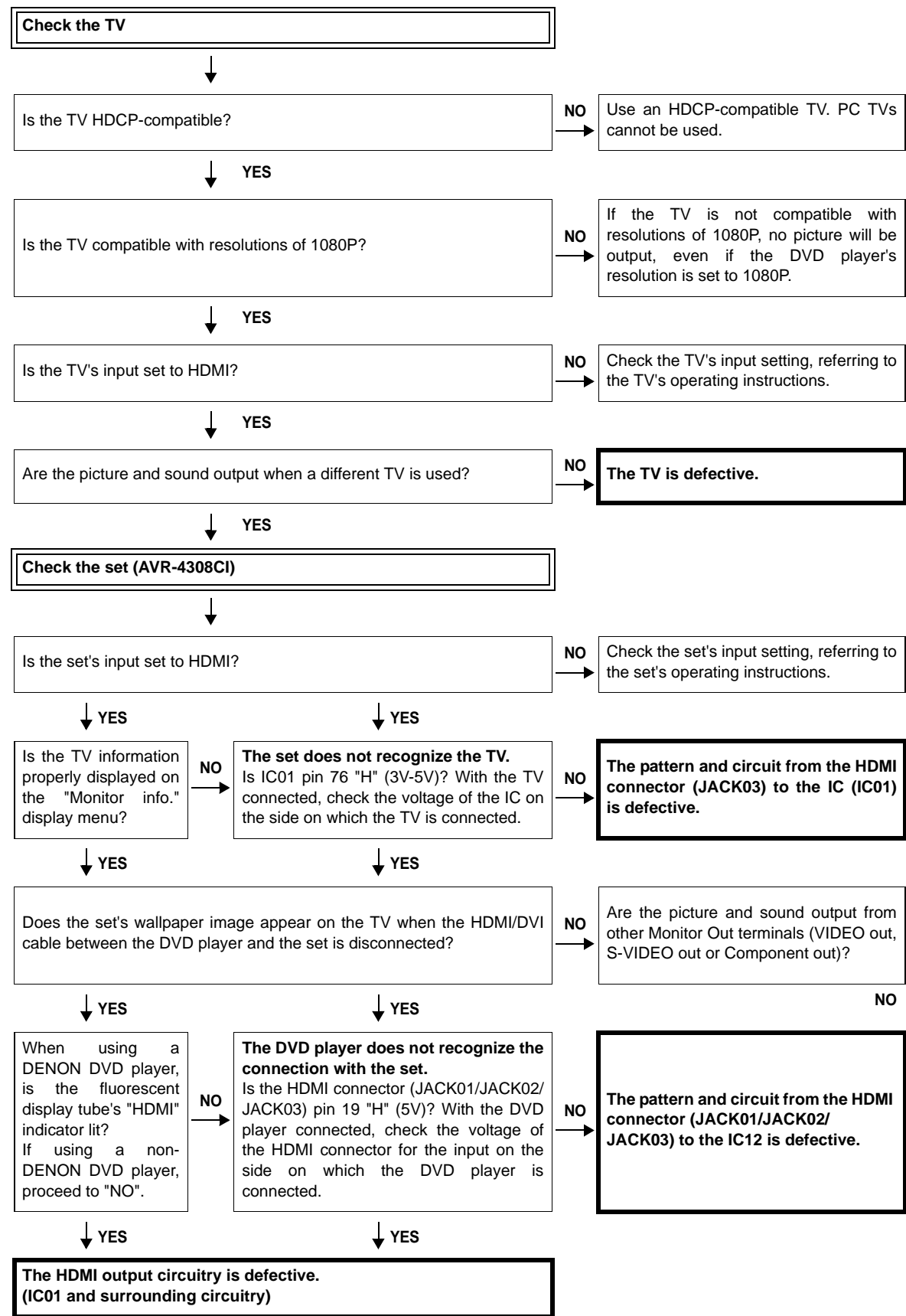

BLOCK DIAGRAM

AUDIO BLOCK DIAGRAM

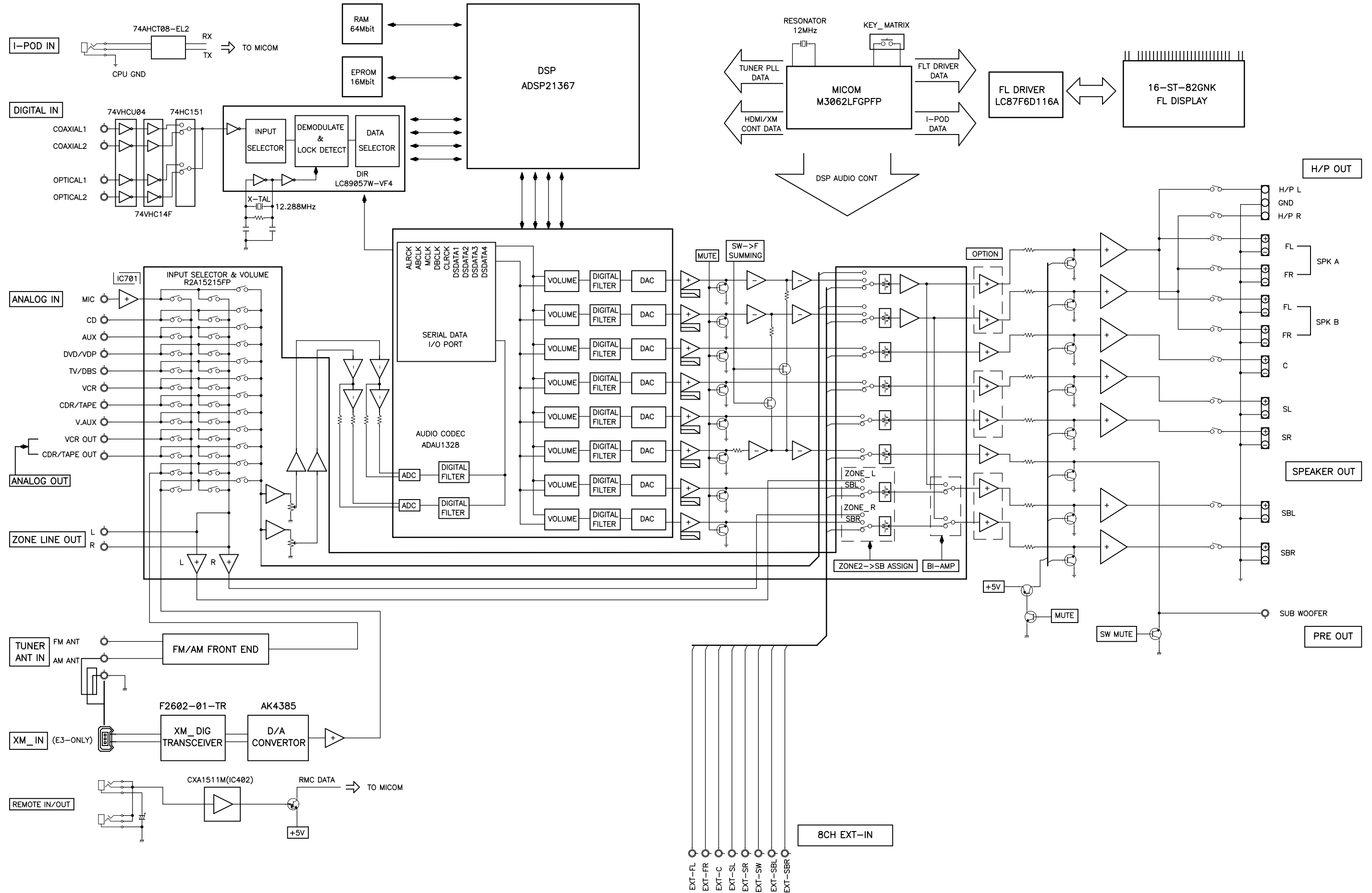

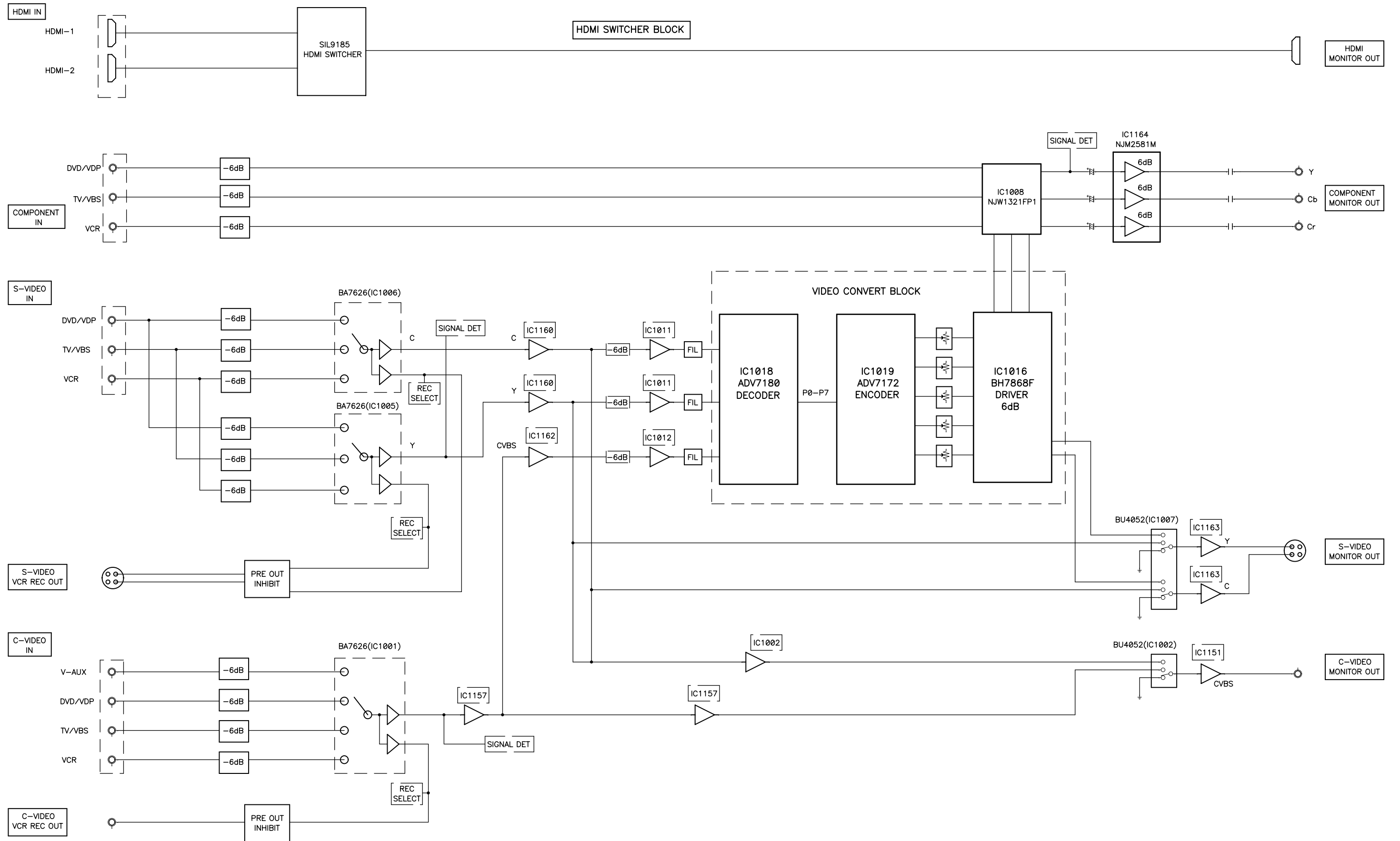

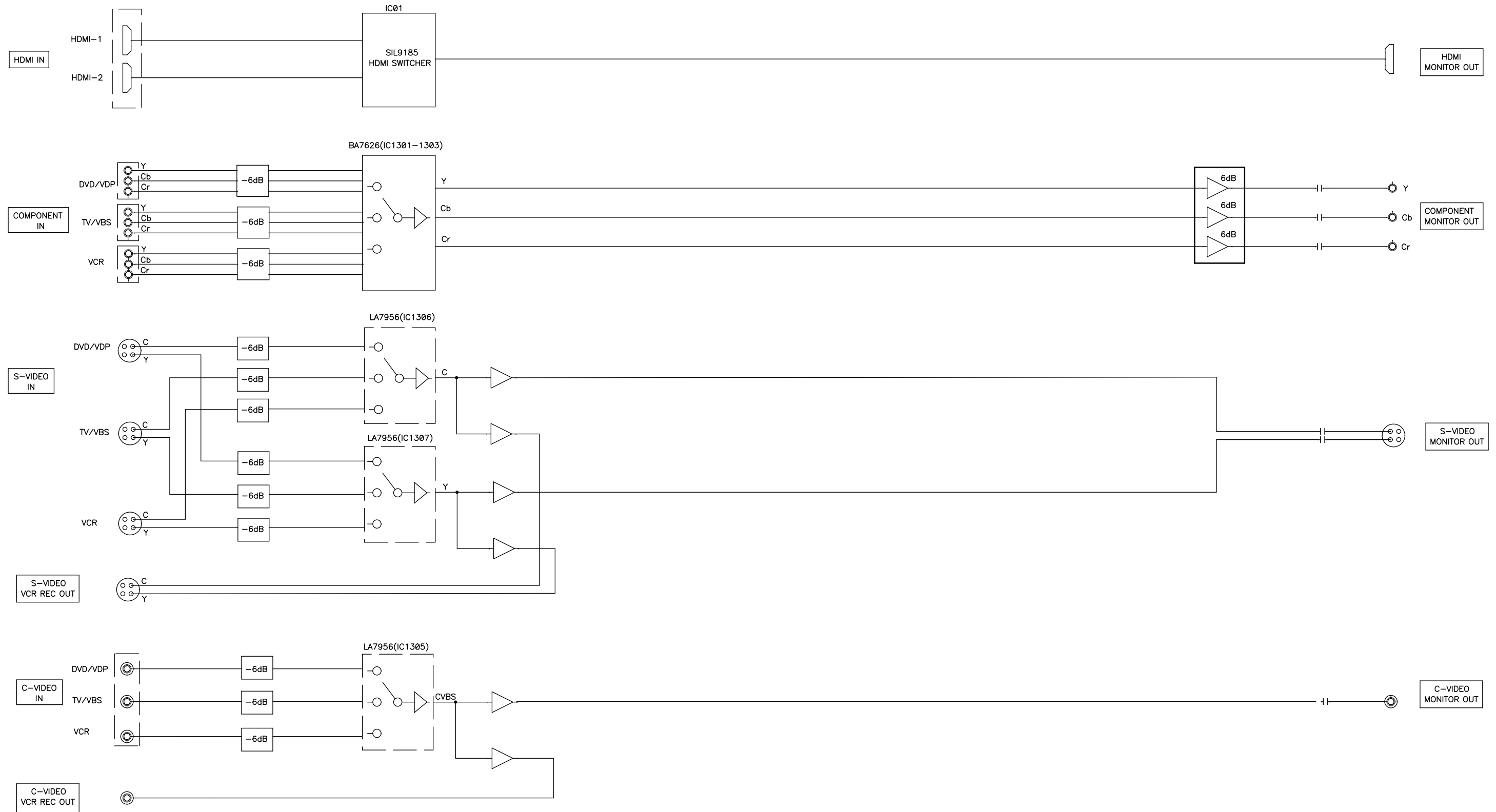

GND DIAGRAM

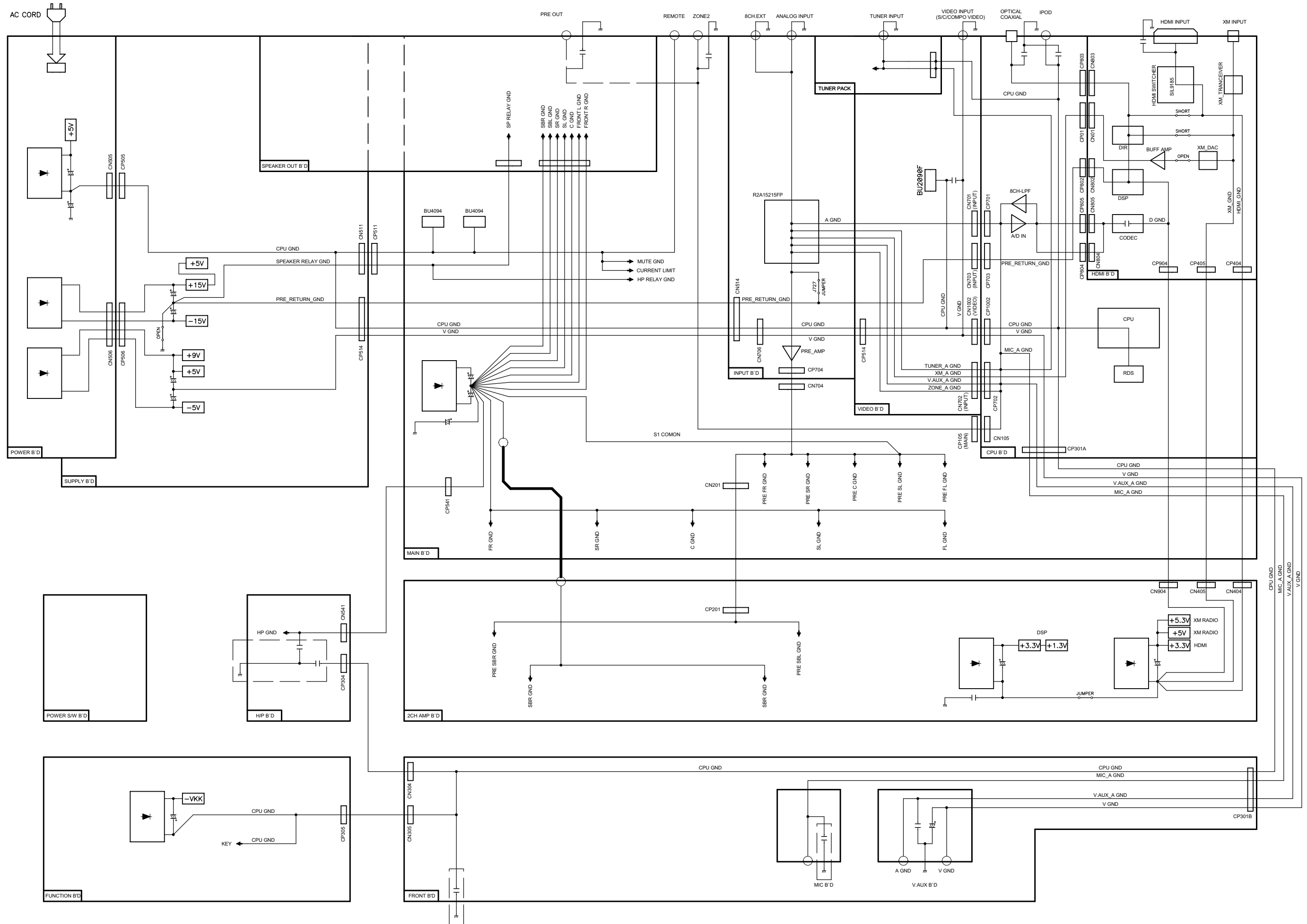

VCC DIAGRAM

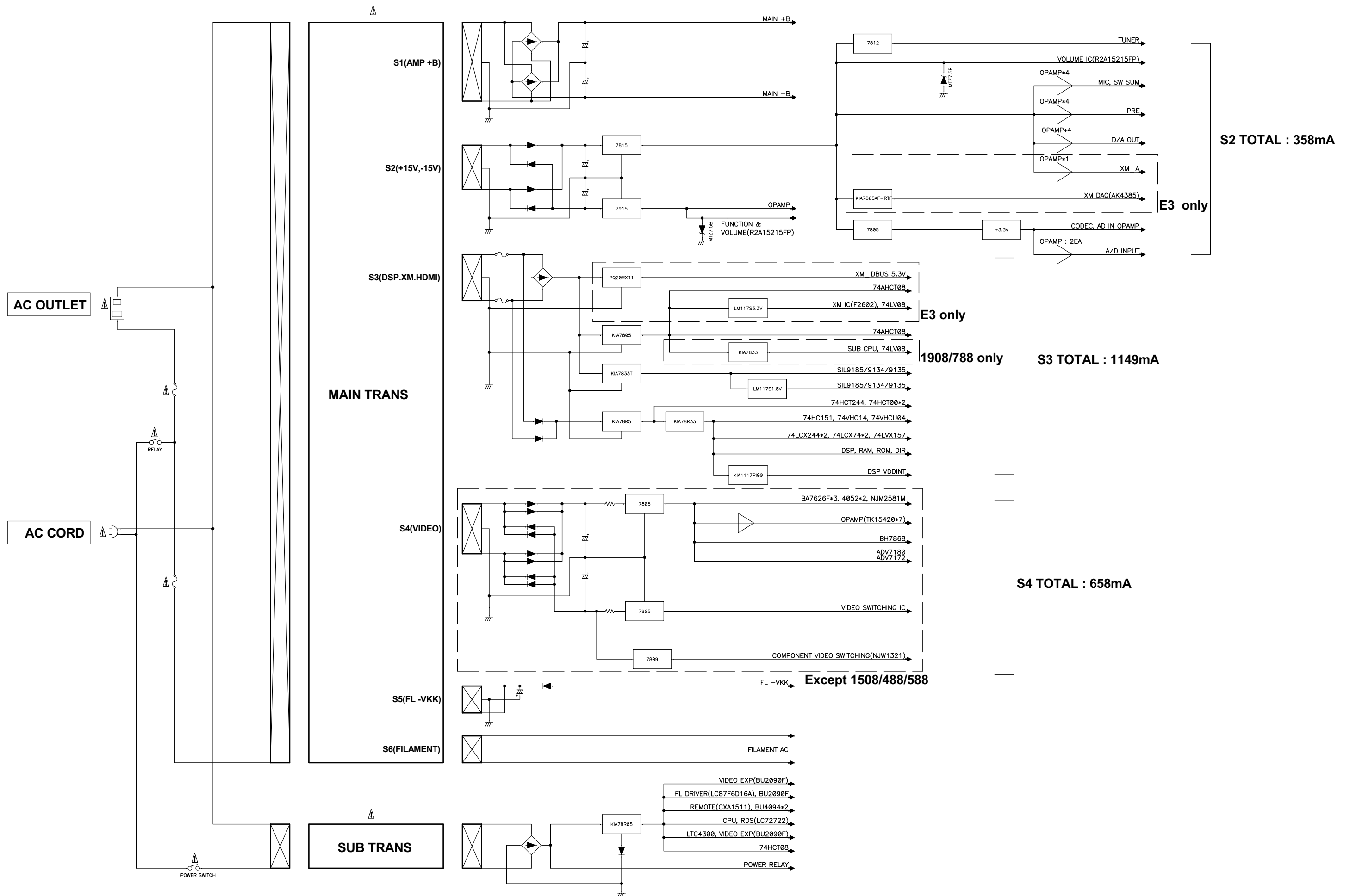

--MEMO--

LEVEL DIAGRAMS (1/2)

7CH LEVEL DIAGRAM

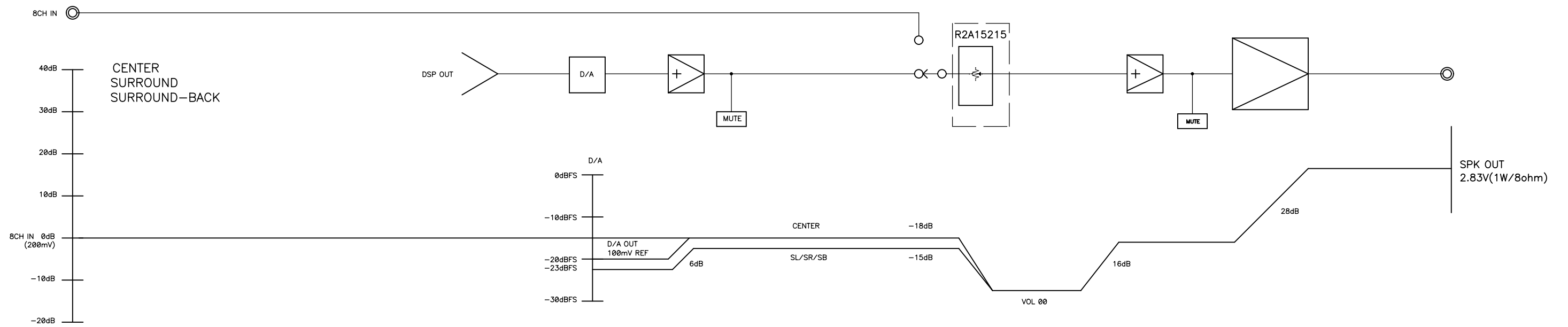
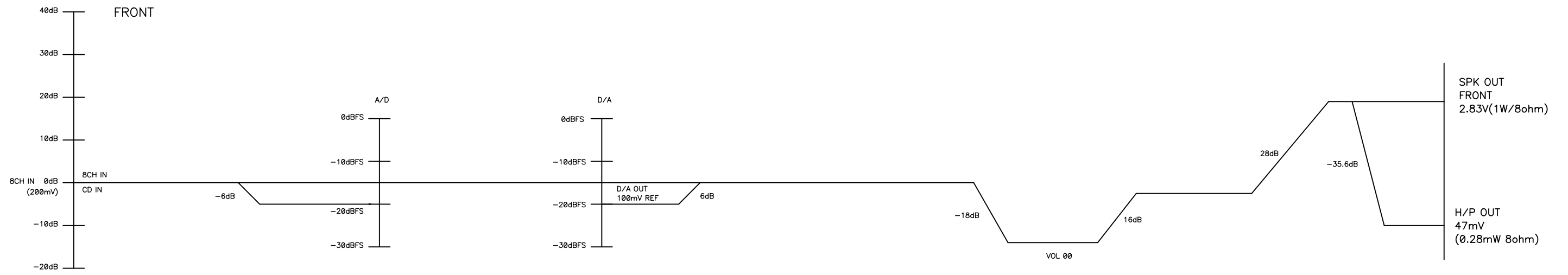
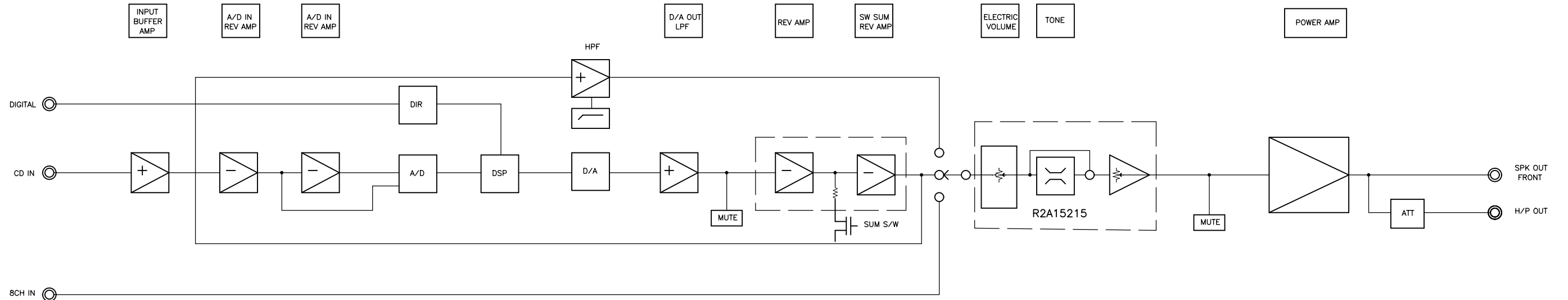

LEVEL DIAGRAMS (2/2)

SUB WOOFER LEVEL DIAGRAM

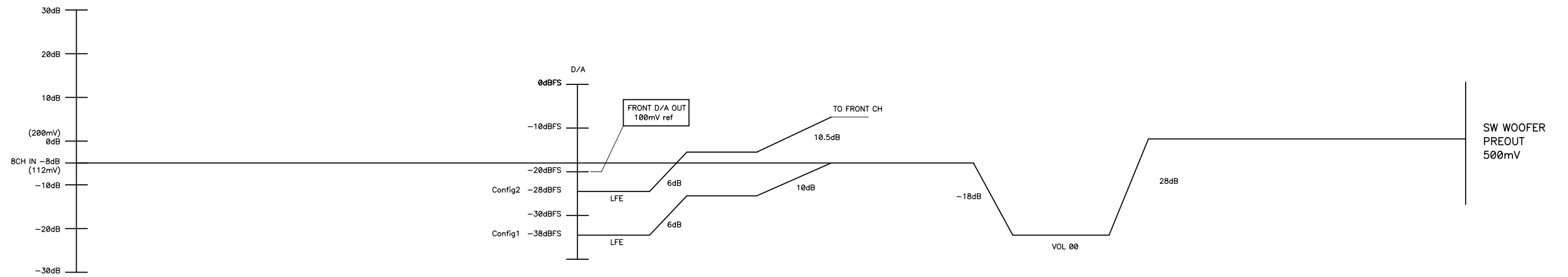
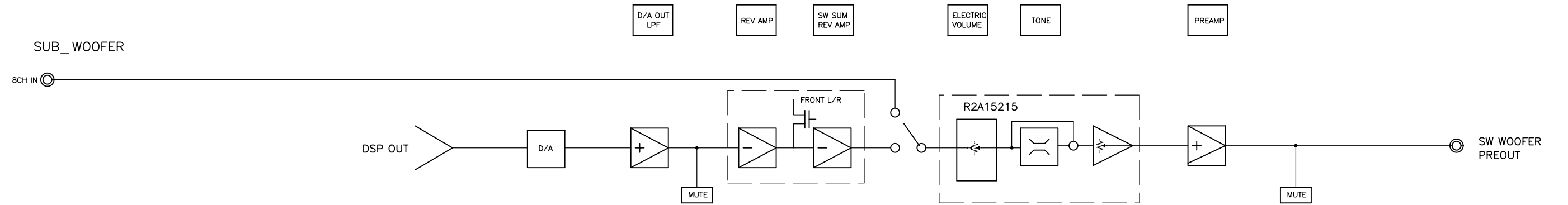

SEMICONDUCTORS

Only major semiconductors are shown, general semiconductors etc. are omitted to list.
 主な半導体を記載しています。汎用の半導体は記載を省略しています。

1. IC's

M30626FHPFP (IC804)

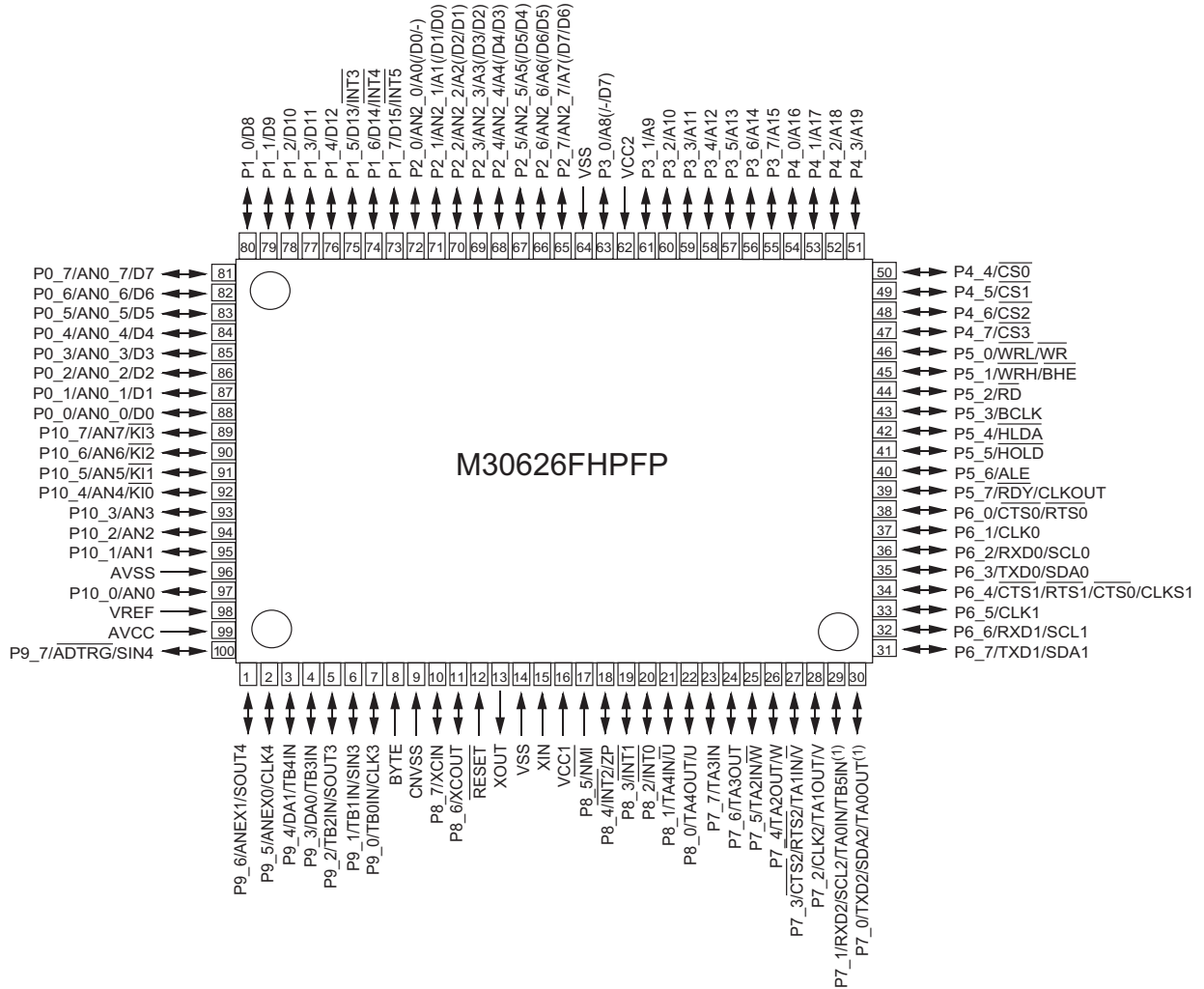

NOTES:

1. P7_0 and P7_1 are N channel open-drain output pins.

M30626FHPFP Terminal Function

PIN NO.	PIN NAME	I/O	FUNCTION
1	P96/SOUT4	SW_SUM	O Bass Management Control
2	P95/CLK4	iPod DET	I iPod Dock Det
3	P94/TB4	2090_CLK/SEL2	O AVR-1708 : EXPANDER Control Pin / AVR-1508 : VIDEO Control Pin
4	P93/TB3	2090_DATA/SEL1	O AVR-1708 : EXPANDER Control Pin / AVR-1508 : VIDEO Control Pin
5	P92/SOUT3	SHARC_SDOUT	O DSP(IC801 : ADSP-21367)Control Pin
6	P91/SIN3	SHARC_SDIN	I DSP(IC801 : ADSP-21367)Control Pin
7	P90/CLK3	SHARC_SCLK	O DSP(IC801 : ADSP-21367)Control Pin
8	BYTE	BYTE	- GND
9	CNVCS	CNVSS	I UPGRADE PIN
10	P87	1328 CE	O CODEC(IC808 : ADAU1328) Control Pin
11	P86	XM DACMS	O XM DAC(IC06 : AK4385)Control Pin
12	RESET	RESET	I RESET (Det = "L")
13	XOUT	X2	O Clock(12MHz)

PIN NO.		PIN NAME	I/O	FUNCTION
14	VSS	VSS	-	GND
15	XIN	X1	I	Clock(12MHz)
16	VCC	VCC	-	+5V
17	P85/NMI	NMI	I	-
18	P84/INT2	FLAG0	I	DSP(IC801 : ADSP-21367) Control Pin
19	P83/INT1	POWER DOWN	I	Power Down Detection Pin (Det = "L")
20	P82/INT0	PROTECTION	I	Protect Detection (Det = "L")
21	P81	XM DAC_CLK(MC)	O	XM DAC(IC06 : AK4385)Control Pin
22	P80	XM DAC_DATA(MDI)	O	XM DAC(IC06 : AK4385)Control Pin
23	P77	FLD_RESET	O	FL DRIVER Control Pin
24	P76	FLD_CE	O	FL DRIVER Control Pin
25	P75	FLD_CLK	O	FL DRIVER Control Pin
26	P74	FLD_DATA	O	FL DRIVER Control Pin
27	P73/CTS2	2090-C_CLK	O	IC301 : BU2090(EXPANDER)Control Pin
28	P72/CLK2	2090-C_DATA	O	IC301 : BU2090(EXPANDER)Control Pin
29	P71/RXD2	RXD MIXMO	I	XM Radio Control Pin
30	P70/TXD2	TXD MOXMI	O	XM Radio Control Pin
31	P67/TXD1	TXD MO232I	O	Flash Starter/DENON Writer Control Pin
32	P66/RXD1	RXD MI232O	I	Flash Starter/DENON Writer Control Pin
33	P65/CLK1	LIMIT DET	I	Current Limit Detection
34	P64/CTS1	LIMIT	O	Current Limit Control Pin
35	P63/TXD0	TXD_iPod	O	iPod Dock Control Pin
36	P62/RXD0	RXD_iPod	I	iPod Dock Control Pin
37	P61/CLK0	XM ANT REV	I	XM Radio Control Pin
38	P60/CTS0	XM LINK ACTIVE	I	XM Radio Control Pin
39	P57	TUNED	I	FM/AM TUNED Detection(Det = "L")
40	P56	STEREO	I	FM STEREO Detection(Det = "L")
41	P55/EPM	FLASH EPM	I	UPGRADE PIN
42	P54	VOL UP	I	MASTER VOLUME KNOB(Rotary Encoder) Rotational Detection
43	P53	VOL DOWN	I	MASTER VOLUME KNOB(Rotary Encoder) Rotational Detection
44	P52	SEL UP	I	SELECTOR KNOB(Rotary Encoder) Rotational Detection
45	P51	SEL DOWN	I	SELECTOR KNOB(Rotary Encoder) Rotational Detection
46	P50/CE	FLASH CE	I	UPGRADE PIN
47	P47	PLL/RDS DIN	O	TUNER PLL(LC72131)/RDS(LC72720)Control Pin
48	P46	PLL/RDS CLK	O	TUNER PLL(LC72131)/RDS(LC72720) Control Pin
49	P45	PLL STB	O	TUNER PLL(LC72131)Control Pin
50	P44	PLL_DOUT	I	TUNER PLL(LC72131)Control Pin
51	P43	RDS RESET	O	RDS(IC805 : LC72720)Control Pin
52	P42	RDS CE	O	RDS(IC805 : LC72720)Control Pin
53	P41	RDS DOUT	I	RDS(IC805 : LC72720)Control Pin
54	P40	89057 INT	I	DIR(IC807 : LC89057) Control Pin
55	P37	89057 RESET	O	DIR(IC807 : LC89057) Control Pin
56	P36	89057 CE	O	DIR(IC807 : LC89057) Control Pin
57	P35	89057 SDIN	I	DIR(IC807 : LC89057) Control Pin
58	P34	89057 EMPHA	I	DIR(IC807 : LC89057) Control Pin
59	P33	V-CODEC RESET/ V-MUTE	O	VIDEO CODEC (IC1019 : ADV7172&IC1018 : ADV7180) Control Pin
60	P32	SHARC_CE	O	DSP(IC801 : ADSP-21367) Control Pin
61	P31	V-CODEC_SDA	O	VIDEO CODEC (IC1019 : ADV7172&IC1018 : ADV7180) Control Pin
62	VCC	VCC	-	+5V
63	P30	V-CODEC_SCL	O	VIDEO CODEC (IC1019 : ADV7172&IC1018 : ADV7180) Control Pin
64	VSS	VSS	-	GND
65	P27	SHARC_RESET	O	DSP(IC801 : ADSP-21367) Control Pin
66	P26	EEPROM RESET	O	Flash Memory(IC803 : MBM29LV160BE90TN) Control Pin
67	P25	DSP POWER	O	DSP POWER ON/OFF
68	P24	HPD0	O	HDMI_IN1 HPD Control Pin

PIN NO.		PIN NAME	I/O	FUNCTION
69	P23	HPD1	O	HDMI_IN2 HPD Control Pin
70	P22	H/P DET	I	HP Jack Insert Detection(Det ="H")
71	P21	FUNCTION UP	I	FUNCTION SELECTOR KNOB(Rotary Encoder)Rotational Detection
72	P20	FUNCTION DOWN	I	FUNCTION SELECTOR KNOB(Rotary Encoder)Rotational Detection
73	P17/INT5	RMC	I	Remote Control Unit Signal Reception
74	P16/INT4	MIC IN	I	MIC Insert Detection(Det ="H")
75	P15/INT3	POWER Key	I	POWER KEY Detection
76	P14/D12	POWER RELAY	O	MAIN TRANS RELAY Control Pin
77	P13/D11	RED LED	O	POWER/STANDBY LED Control Pin
78	P12/D10	VOL DATA	O	FUNCTION/VOLUME(IC700 : R2A15215) Control Pin
79	P11/D9	VOL CLK	O	FUNCTION/VOLUME(IC700 : R2A15215) Control Pin
80	P10/D8	1328 SDIN/ MIC OVERLOAD	I	CODEC(IC808 : ADAU1328) Control Pin
81	P07/D7	4094(MUTE)_STB	O	IC111 : BU4094(EXPANDER) Control Pin
82	P06/D6	4094(RLY)_STB	O	IC110 : BU4094(EXPANDER) Control Pin
83	P05/D5	4094(XM)_STB	O	IC12 : BU4094(EXPANDER) Control Pin
84	P04/D4	89057/1328 SCLK	O	DIR(IC807 : LC89057)&CODEC(IC808 : ADAU1328) Control Pin
85	P03/D3	89057/1328 SDOUT	O	DIR(IC807 : LC89057)&CODEC(IC808 : ADAU1328) Control Pin
86	P02/D2	COMP DET	I	COMPONENTSignal Detection (AVR-1708/688 Only)
87	P01/D1	CVBS DET	I	CONPOSIT Signal Detection (AVR-1708/688 Only)
88	P00/D0	S-VIDEO DET	I	S VIDEO Signal Detection (AVR-1708/688 Only)
89	P107/AN7	4094_OE	O	IC12&110&111 : BU4094(EXPANDER) Control Pin
90	P106/AN6	KEY1	I	Key-1 Detection(A/D)
91	P105/AN5	KEY2	I	Key-2 Detection(A/D)
92	P104/AN4	KEY3	I	Key-3 Detection(A/D)
93	P103/AN3	1328 RESET	O	CODEC(IC808 : ADAU1328) Control Pin
94	P102/AN2	SET OPTION	I	Area Setup
95	P101	4094_CLK	O	IC12&110&111 : BU4094(EXPANDER) Control Pin
96	AVSS	AVSS	-	GND
97	P100	4094_DATA	O	IC12&110&111 : BU4094(EXPANDER) Control Pin
98	VREF	VREF	-	AD Reference Level(+5V)
99	AVCC	AVCC	-	AD +5V
100	P97/SIN4	INH	O	Identifying Signal Control (AVC-1508 Only)

R2A15215FP (IC700)

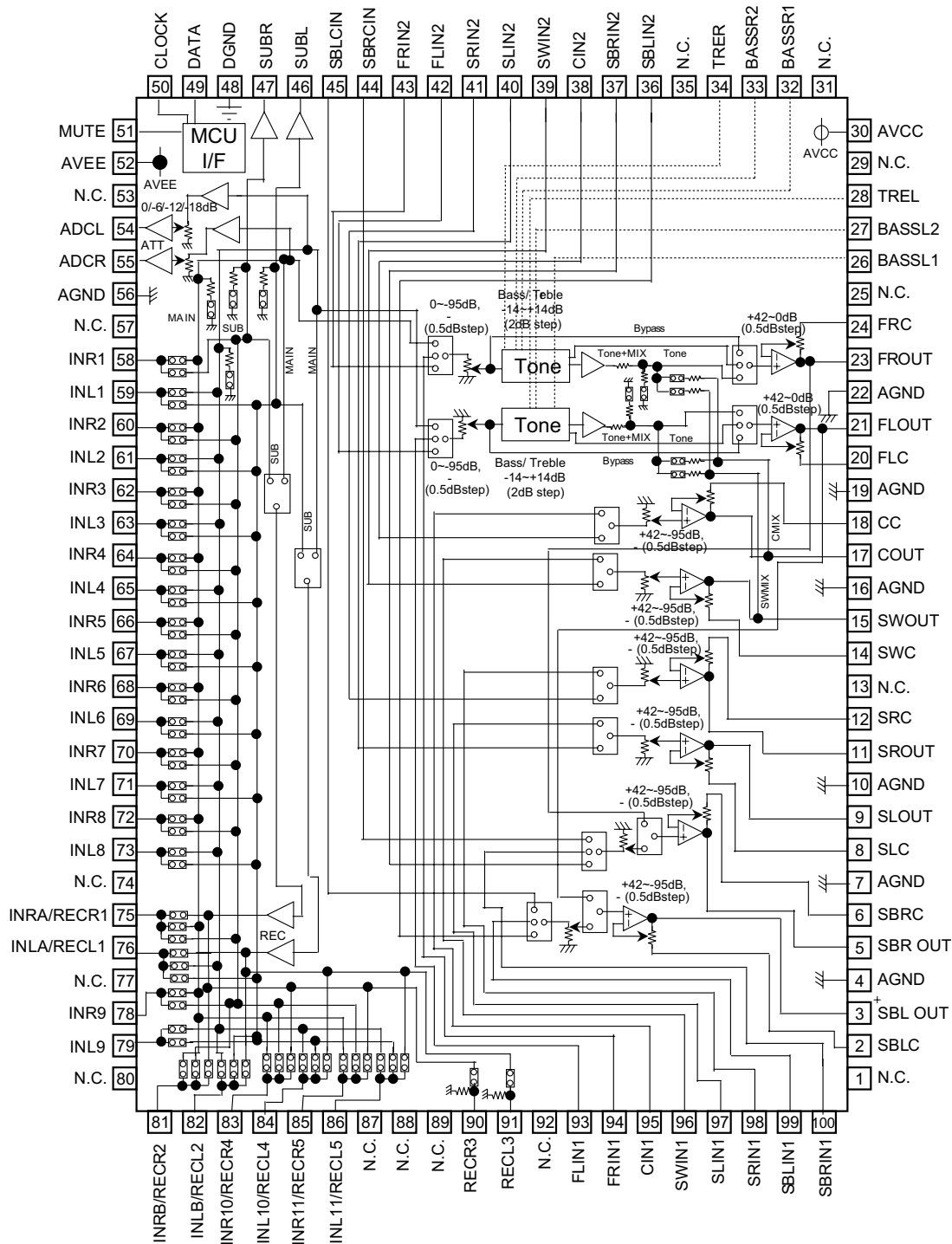
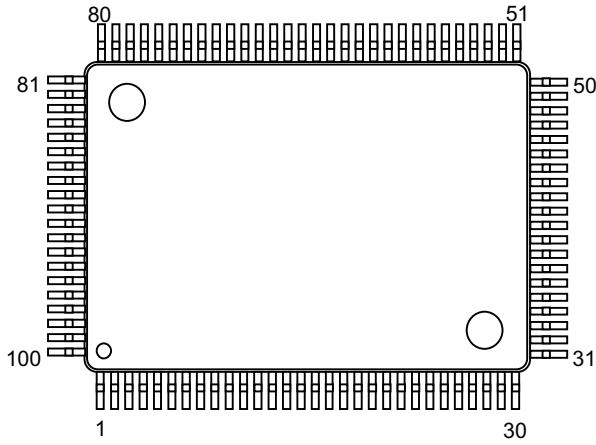

R2A15215FP Terminal Function

PIN No.	Name	Function
23,21, 17,15, 11,9, 5,3	FROUT,FLO UT, COUT,SWOUT, SROUT, SLO UT, SBROUT,SBL OUT	Output pin of FL/ FR/C/SW/SL/ SR/SBL/ SBR channel
24,20, 18,14, 12,8, 6,2	FRC,FLC, CC,SWC, SRC,SLC, SBRC,SBL C	Connects capacitor fo r reducing click no ise of L/R/C/SW/SL/SR/SBL/ SBR channel vol ume
4,7,10,16, 19,22,56	AGN D	Analog ground of intern al circuit
28,34	TREL, TRE R	Frequency characteristic setting pin of L/R chann el tone control (Treble)
26,27, 32,33	BA SSL1,BA SSL2 BA SSR1,BASSR2	Frequency characteristic setting pin of L/R chann el tone control (Bass)
30	AVCC	Positive power supply to internal circuit
43,42, 41,40, 39,38, 37,36	FRIN2, FLIN2, SRN2,SLIN2, SWIN2,CIN2 , SBRIN2,SBLIN2	Input pin of L/R /C/SW/SL/ SR/SBL /SBR channel (Multi IN 1/2)
93,94, 95,96, 97,98, 99,100	FLIN1, F RIN1, CIN1,SWIN1 , SLIN1,S RIN1, SBLIN1,S BRIN1	
48	DGND	Digital ground of intern al circuit
49	DATA	Input pin of c ontrol data
50	CLOCK	Input pin of c ontrol clock
52	AVEE	Negative pow er supply to internal cir cuit
59,61,63, 65,67,69, 71,73,79	INL1, INL2, I NL3, INL4, INL5, INL6, INL7, INL8, INL9	Input pin of L/R channel (Input Selector)
58,60,62, 64,66,68, 70,72,78	INR1,INR2, I NR3, INR4,INR5,I NR6, INR7,INR8,I NR9	
51	MUTE	Outside Mute Control PIN
44,45	SBRCIN,SBL CIN	Input pin for S BL/ SBR channel Volum e
46,47	SUBL,SU BR	Output pin for L/R chann el SUB Output
54,55	ADCL, ADCR	Output pin for L/R chann el ADC
90,91	RECR3,RECL3	Output pin for L/R chann el REC Output
75,76, 81,82, 83,84, 85,86	INRA/RECR1,INLA/RECL1, INRB/REC R2,INLB/ RECL2, INR10/RECR4,I NL10/RECL4, INR11/RECR5,I NL11/RECL5	Input pin of L/R channel (Input Selector)/ Output pin for L/R chann el REC Output
1,13,25,29,31, 35,53, 57,74,77,80, 87,88,89,92	N.C.	No Connected PIN

ADSP21367 (IC801)

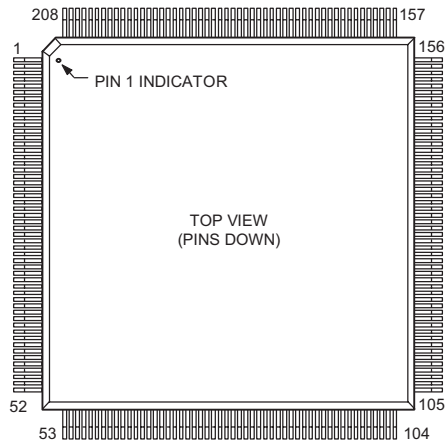

ADSP21367 Terminal Function

Pin No.	Signal	Pin No.	Signal	Pin No.	Signal	Pin No.	Signal
1	VDD	53	VDD	105	VDD	157	VDD
2	DATA28	54	GND	106	GND	158	VDD
3	DATA27	55	IOVDD	107	IOVDD	159	GND
4	GND	56	ADDR0	108	$\overline{\text{SDCAS}}$	160	VDD
5	IOVDD	57	ADDR2	109	$\overline{\text{SDRAS}}$	161	VDD
6	DATA26	58	ADDR1	110	SDCKE	162	VDD
7	DATA25	59	ADDR4	111	SDWE	163	TDI
8	DATA24	60	ADDR3	112	$\overline{\text{WR}}$	164	$\overline{\text{TRST}}$
9	DATA23	61	ADDR5	113	SDA10	165	TCK
10	GND	62	GND	114	GND	166	GND
11	VDD	63	VDD	115	IOVDD	167	VDD
12	DATA22	64	GND	116	SDCLK0	168	TMS
13	DATA21	65	IOVDD	117	GND	169	CLK_CFG0
14	DATA20	66	ADDR6	118	VDD	170	BOOTCFG0
15	IOVDD	67	ADDR7	119	$\overline{\text{RD}}$	171	CLK_CFG1
16	GND	68	ADDR8	120	ACK	172	$\overline{\text{EMU}}$
17	DATA19	69	ADDR9	121	FLAG3	173	BOOTCFG1
18	DATA18	70	ADDR10	122	FLAG2	174	TDO
19	VDD	71	GND	123	FLAG1	175	DAI4
20	GND	72	VDD	124	FLAG0	176	DAI2
21	DATA17	73	GND	125	DAI20	177	DAI3
22	VDD	74	IOVDD	126	GND	178	DAI1
23	GND	75	ADDR11	127	VDD	179	IOVDD
24	VDD	76	ADDR12	128	GND	180	GND
25	GND	77	ADDR13	129	IOVDD	181	VDD
26	DATA16	78	GND	130	DAI19	182	GND
27	DATA15	79	VDD	131	DAI18	183	DPI14
28	DATA14	80	AVSS	132	DAI17	184	DPI13
29	DATA13	81	AVDD	133	DAI16	185	DPI12
30	DATA12	82	GND	134	DAI15	186	DPI11
31	IOVDD	83	CLKIN	135	DAI14	187	DPI10
32	GND	84	XTAL2	136	DAI13	188	DPI9
33	VDD	85	IOVDD	137	DAI12	189	DPI8
34	GND	86	GND	138	VDD	190	DPI7
35	DATA11	87	VDD	139	IOVDD	191	IOVDD
36	DATA10	88	ADDR14	140	GND	192	GND
37	DATA9	89	GND	141	VDD	193	VDD
38	DATA8	90	IOVDD	142	GND	194	GND
39	DATA7	91	ADDR15	143	DAI11	195	DPI6
40	DATA6	92	ADDR16	144	DAI10	196	DPI5
41	IOVDD	93	ADDR17	145	DAI8	197	DPI4
42	GND	94	ADDR18	146	DAI9	198	DPI3
43	VDD	95	GND	147	DAI6	199	DPI1
44	DATA4	96	IOVDD	148	DAI7	200	DPI2
45	DATA5	97	ADDR19	149	DAI5	201	CLKOUT
46	DATA2	98	ADDR20	150	IOVDD	202	$\overline{\text{RESET}}$
47	DATA3	99	ADDR21	151	GND	203	IOVDD
48	DATA0	100	ADDR23	152	VDD	204	GND
49	DATA1	101	ADDR22	153	GND	205	DATA30
50	IOVDD	102	$\overline{\text{MS1}}$	154	VDD	206	DATA31
51	GND	103	$\overline{\text{MS0}}$	155	GND	207	DATA29
52	VDD	104	VDD	156	VDD	208	VDD

LC89057W (IC807)

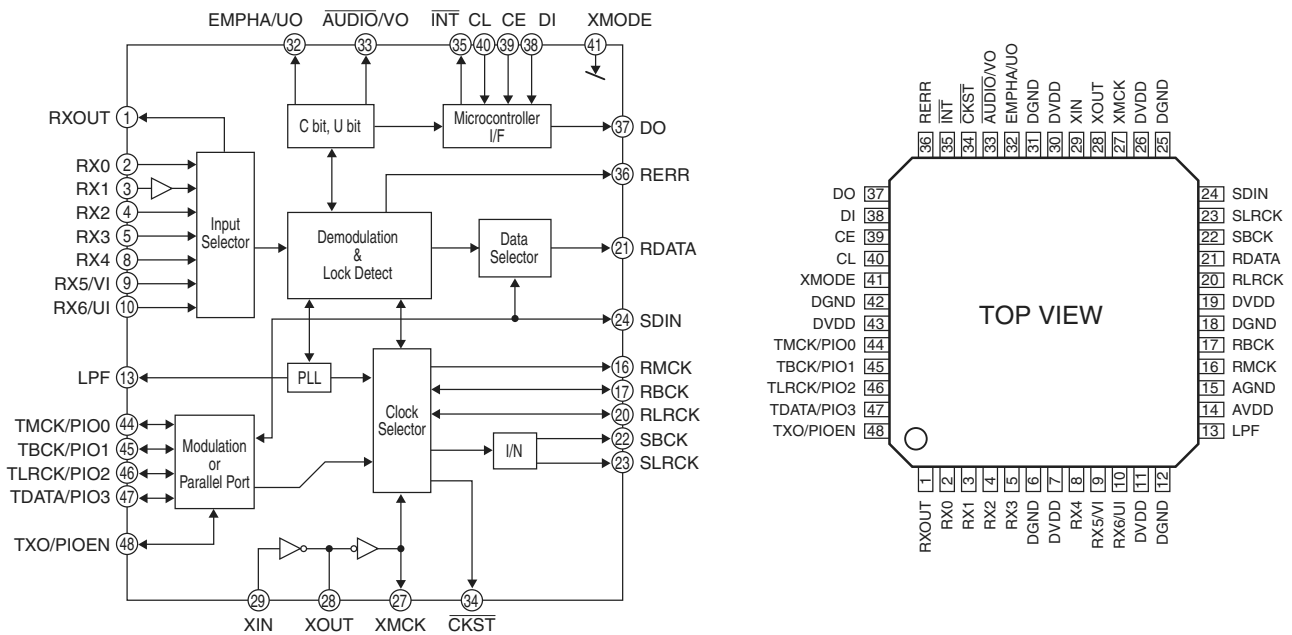

LC89057W Terminal Function

Pin No.	Pin Name	I/O	Function
1	RXOUT	O	Input bi-phase select data output terminal
2	RX0	I	TTL compatible digital data input terminal
3	RX1	I	Coaxial compatible amp built-in digital data input terminal
4	RX2	I	TTL compatible digital data input terminal
5	RX3	I	TTL compatible digital data input terminal
6	DGND	—	Digital GND
7	DVDD	—	Digital power
8	RX4	I	TTL compatible digital data input terminal
9	RX5/VI	I	TTL compatible digital data/Validity flag input terminal for modulation
10	RX6/UI	I	TTL compatible digital data/User data input terminal for modulation
11	DVDD	—	Digital power for PLL
12	DGND	—	Digital GND for PLL
13	LPF	O	PLL loop filter connecting terminal
14	AVDD	—	Analog power for PLL
15	AGND	—	Analog GND for PLL
16	RMCK	O	RMCK clock output terminal (256fs, 512fs, XIN, VCO)
17	RBCK	O/I	RBCK clock in/output terminal (64fs)
18	DGND	—	Digital GND
19	DVDD	—	Digital power
20	RLRCK	O/I	RLRCK clock in/output terminal (fs)
21	RDATA	O	Serial audio data output terminal
22	SBCK	O	SBCK clock output terminal (32fs, 64fs, 128fs)
23	SLRCK	O	SLRCK clock output terminal (fs/2, fs, 2fs)
24	SDIN	I	Serial audio data input terminal
25	DGND	—	Digital GND
26	DVDD	—	Digital power
27	XMCK	O	Osc. amp output terminal

Pin No.	Pin Name	I/O	Function
28	XOUT	O	X'tal osc. connecting output terminal
29	XIN	I	X'tal osc. connection, external clock input terminal (24.576MHz or 12.288MHz)
30	DVDD	—	Digital power
31	DGND	—	Digital GND
32	EMPHA/UO	I/O	Emphasis information/U-data output/Chip address setting terminal
33	AUDIO/VO	I/O	Non-PCM detect/V-flag output/ Chip address setting terminal
34	CKST	I/O	Clock switch transition period output/Demodulation master or slave function switching terminal
35	INT	I/O	Interrupt output for μ com (Interrupt factor selectable)/Modulation or general I/O switching terminal
36	RERR	O	PLL lock error, data error flag output
37	DO	O	μ com I/F, read out data output terminal (3-state)
38	DI	I	μ com I/F, write data input terminal
39	CE	I	μ com I/F, chip enable input terminal
40	CL	I	μ com I/F, clock input terminal
41	XMODE	I	System reset input terminal
42	DGND	—	Digital GND
43	DVDD	—	Digital power
44	TMCK/PIO0	I/O	256fs system clock input for modulation/General I/O in/output terminal
45	TBCK/PIO1	I/O	64fs bit clock input for modulation/General I/O in/output terminal
46	TLRCK/PIO2	I/O	fs clock input for modulation/General I/O in/output terminal
47	TDATA/PIO3	I/O	Serial audio data input for modulation/General I/O in/output terminal
48	TXO/PIOEN	O/I	Modulation data output/ General I/O enable input terminal

* For latch-up countermeasure, perform each power supply ON/OFF in the same timing.

BU2090F (IC302,1005,1008)

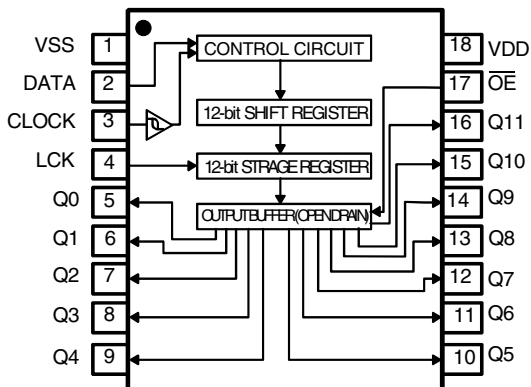

MM74LCX244 (IC809-811)

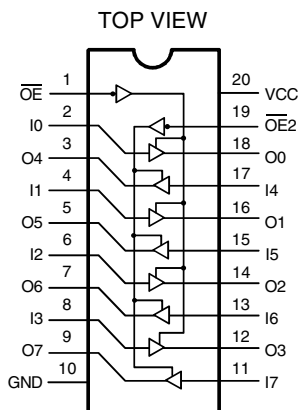

LC87F6D16A (IC302)

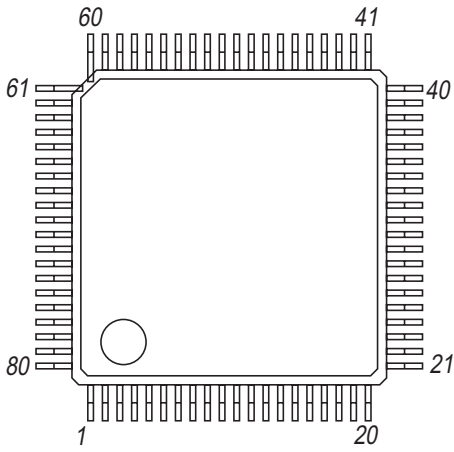

PIN NO.	PORT NAME	I/O	OUT PORT TYPE	Function	Initial
01	I03	I/O	CMOS	GENERAL I/O	
02	I04	I/O	CMOS	GENERAL I/O	
03	I05	I/O	CMOS	GENERAL I/O	
04	I06	I/O	CMOS	GENERAL I/O	
05	CE	I	-	DATA CE	
06	RES#				
07	VSS1				
08	CF1/XT1				
09	CF2/XT2				
10	VDD1				
11	KEY1	I	-	KEY1	
12	KEY2	I	-	KEY2	
13	KEY3	I	-	KEY3	
14	KEY4	I	-	KEY4	
15	ENCA+	I	-	ENCODER 1A	
16	ENCA-	I	-	ENCODER 1B	
17	ENCB+	I	-	ENCODER 2A	
18	ENCB-	I	-	ENCODER 2B	
19	I01	I/O	N-OD	GENERAL I/O	
20	I02	I/O	CMOS	GENERAL I/O	
21	GRID1	0	P-OD (PULLDOWN)	GRID1	
22	GRID2	0	P-OD (PULLDOWN)	GRID2	
23	GRID3	0	P-OD (PULLDOWN)	GRID3	
24	GRID4	0	P-OD (PULLDOWN)	GRID4	
25	GRID5	0	P-OD (PULLDOWN)	GRID5	
26	GRID6	0	P-OD (PULLDOWN)	GRID6	
27	GRID7	0	P-OD (PULLDOWN)	GRID7	
28	GRID8	0	P-OD (PULLDOWN)	GRID8	
29	GRID9	0	P-OD (PULLDOWN)	GRID9	
30	GRID10	0	P-OD (PULLDOWN)	GRID10	
31	GRID11	0	P-OD (PULLDOWN)	GRID11	
32	GRID12	0	P-OD (PULLDOWN)	GRID12/AD8	
33	GRID13	0	P-OD (PULLDOWN)	GRID13/AD7	
34	GRID14	0	P-OD (PULLDOWN)	GRID14/AD6	
35	GRID15	0	P-OD (PULLDOWN)	GRID15/AD5	
36	GRID16	0	P-OD (PULLDOWN)	GRID16/AD4	
37	VP1				
38	VDD2				
39	SEG1	0	P-OD (PULLDOWN)	AD3	
40	SEG2	0	P-OD (PULLDOWN)	AD2	
41	SEG3	0	P-OD (PULLDOWN)	AD1	
42	SEG4	0	P-OD (PULLDOWN)	AM35	
43	SEG5	0	P-OD (PULLDOWN)	AM34	
44	SEG6	0	P-OD (PULLDOWN)	AM33	
45	SEG7	0	P-OD (PULLDOWN)	AM32	
46	SEG8	0	P-OD (PULLDOWN)	AM31	
47	SEG9	0	P-OD (PULLDOWN)	AM30	
48	SEG10	0	P-OD (PULLDOWN)	AM29	
49	SEG11	0	P-OD (PULLDOWN)	AM28	
50	SEG12	0	P-OD (PULLDOWN)	AM27	
51	SEG13	0	P-OD (PULLDOWN)	AM26	
52	SEG14	0	P-OD (PULLDOWN)	AM25	
53	SEG15	0	P-OD (PULLDOWN)	AM24	
54	SEG16	0	P-OD (PULLDOWN)	AM23	
55	SEG17	0	P-OD (PULLDOWN)	AM22	
56	SEG18	0	P-OD (PULLDOWN)	AM21	
57	SEG19	0	P-OD (PULLDOWN)	AM20	
58	SEG20	0	P-OD (PULLDOWN)	AM19	
59	SEG21	0	P-OD (PULLDOWN)	AM18	
60	SEG22	0	P-OD (PULLDOWN)	AM17	
61	SEG23	0	P-OD (PULLDOWN)	AM16	
62	SEG24	0	P-OD (PULLDOWN)	AM15	
63	VDD3				
64	SEG25	0	P-OD (PULLDOWN)	AM14	
65	SEG26	0	P-OD (PULLDOWN)	AM13	
66	SEG27	0	P-OD (PULLDOWN)	AM12	
67	SEG28	0	P-OD (PULLDOWN)	AM11	
68	SEG29	0	P-OD (PULLDOWN)	AM10	
69	SEG30	0	P-OD (PULLDOWN)	AM9	
70	SEG31	0	P-OD (PULLDOWN)	AM8	
71	SEG32	0	P-OD (PULLDOWN)	AM7	
72	SEG33	0	P-OD (PULLDOWN)	AM6	
73	SEG34	0	P-OD (PULLDOWN)	AM5	
74	SEG35	0	P-OD (PULLDOWN)	AM4	
75	SEG36	0	P-OD (PULLDOWN)	AM3	
76	SEG37	0	P-OD (PULLDOWN)	AM2	
77	SEG38	0	P-OD (PULLDOWN)	AM1	
78	S01	0	CMOS	DATA OUT	
79	S11	I	-	DATA IN	
80	SCLK	I	-	DATA CLOCK	

ADAU1328 (IC808)

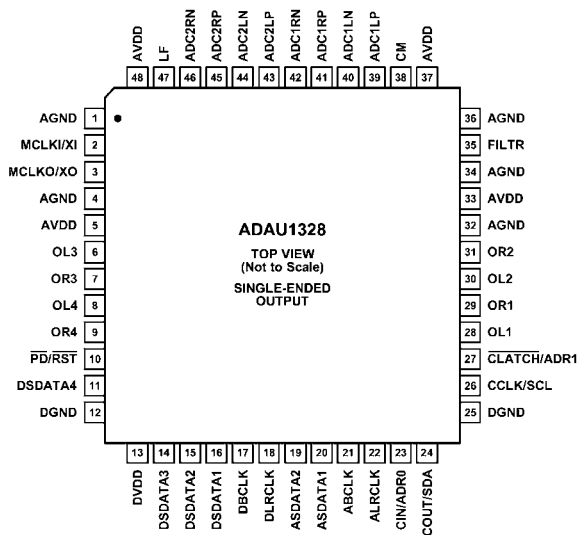

Pin No.	In/Out	Mnemonic	Description
1	I	AGND	Analog Ground.
2	I	MCLKI/XI	Master Clock Input/Crystal Oscillator Input.
3	O	MCLKO/XO	Master Clock Output/Crystal Oscillator Output.
4	I	AGND	Analog Ground.
5	I	AVDD	Analog Power Supply. Connect to analog 3.3 V supply.
6	O	OL3	DAC 3 Left Output.
7	O	OR3	DAC 3 Right Output.
8	O	OL4	DAC 4 Left Output.
9	O	OR4	DAC 4 Right Output.
10	I	PD/RST	Power-Down Reset (Active Low).
11	I/O	DSDATA4	DAC Input 4 (Input to DAC 4 L and R)/DAC TDM Data Out 2/AUX ADC 1 Data In.
12	I	DGND	Digital Ground.
13	I	DVDD	Digital Power Supply. Connect to digital 3.3 V supply.
14	I/O	DSDATA3	DAC Input 3 (Input to DAC 3 L and R)/DAC TDM Data In 2/AUX DAC 2 Data Output.
15	I/O	DSDATA2	DAC Input 2 (Input to DAC 2 L and R)/DAC TDM Data Out 1/AUX ADC 1 Data In.
16	I	DSDATA1	DAC Input 1 (Input to DAC 1 L and R)/DAC TDM Data In 1/AUX ADC 2 Data In.
17	I/O	DBCLK	Bit Clock for DACs.
18	I/O	DLRCLK	LR Clock for DACs.
19	I/O	ASDATA2	ADC Serial Data Output 2 (ADC 2 L and R)/ADC TDM Data Input/AUX DAC 1 Data Output.
20	O	ASDATA1	ADC Serial Data Output 1 (ADC 1 L and R)/ADC TDM Data Output.
21	I/O	ABCLK	Bit Clock for ADCs.
22	I/O	ALRCLK	LR Clock for ADCs.
23	I	CIN/ADRO	Control Data Input (SPI).
24	I/O	COUT/SDA	Control Data Output (SPI).
25	I	DGND	Digital Ground.
26	I	CCLK/SCL	Control Clock Input (SPI).
27	I	CLATCH/ADR1	Latch Input for Control Data (SPI).
28	O	OL1	DAC 1 Left Output.
29	O	OR1	DAC 1 Right Output.
30	O	OL2	DAC 2 Left Output.
31	O	OR2	DAC 2 Right Output.
32	I	AGND	Analog Ground.
33	I	AVDD	Analog Power Supply. Connect to analog 3.3 V supply.
34	I	AGND	Analog Ground.
35	O	FILTR	Voltage Reference Filter Capacitor Connection. Bypass with 10 μ F 100 nF to AGND.
36	I	AGND	Analog Ground.
37	I	AVDD	Analog Power Supply. Connect to analog 3.3 V supply.
38	O	CM	Common-Mode Reference Filter Capacitor Connection. Bypass with 47 μ F 100 nF to AGND.
39	I	ADC1LP	ADC1 Left Positive Input.
40	I	ADC1LN	ADC1 Left Negative Input.
41	I	ADC1RP	ADC1 Right Positive Input.
42	I	ADC1RN	ADC1 Right Negative Input.
43	I	ADC2LP	ADC2 Left Positive Input.
44	I	ADC2LN	ADC2 Left Negative Input.
45	I	ADC2RP	ADC2 Right Positive Input.
46	I	ADC2RN	ADC2 Right Negative Input.
47	O	LF	PLL Loop Filter. Return to AVDD.
48	I	AVDD	Analog Power Supply. Connect to analog 3.3 V supply.

**BA7626 (IC1001,1005,1006 : for AVR1707/687 model)
 (IC652,653 : for AVR1507/487 model)
 BA7625 (IC651 : for AVR1507/487 model)**

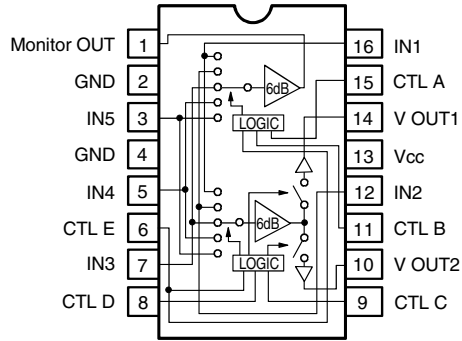

A	B	E	MONITOR OUT
L	L	*	IN 1
H	L	*	IN 2
L	H	*	IN 3
H	H	L	IN 4
H	H	H	IN 5

C	D	E	V OUT 1
L	L	*	—
H	L	*	IN 2
L	H	*	IN 3
H	H	L	IN 4
H	H	H	IN 5

C	D	E	V OUT 2
L	L	*	IN 1
H	L	*	—
L	H	*	IN 3
H	H	L	IN 4
H	H	H	IN 5

Note 1: * mark means that feasible for either H or L.
 Note 2: Each input terminal is provided with sink chip clamp (BA7625).
 Each input terminal takes 20kohm at the end (BA7626).

74LVX157MTC (IC816)

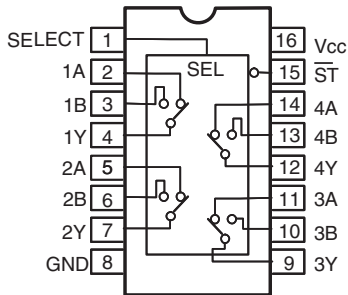

BA4510F (IC824,827)

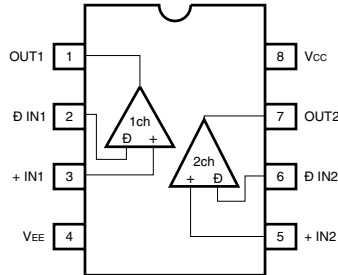

BU4094BCF (IC12,110,111)

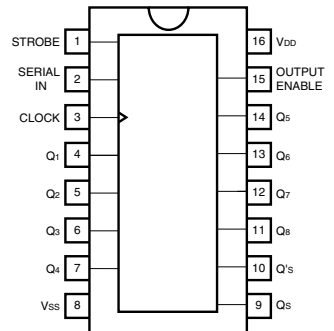

MM74HCT244 (IC812)

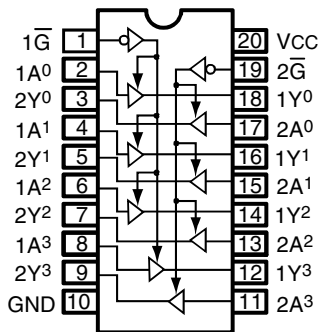

**FAN1117-1.2 (IC824)
 RC1117-33 (IC823)**

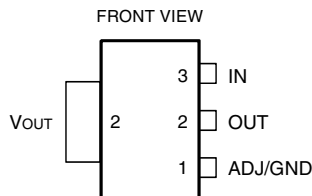

MBM29LV160BE90TN (IC803)

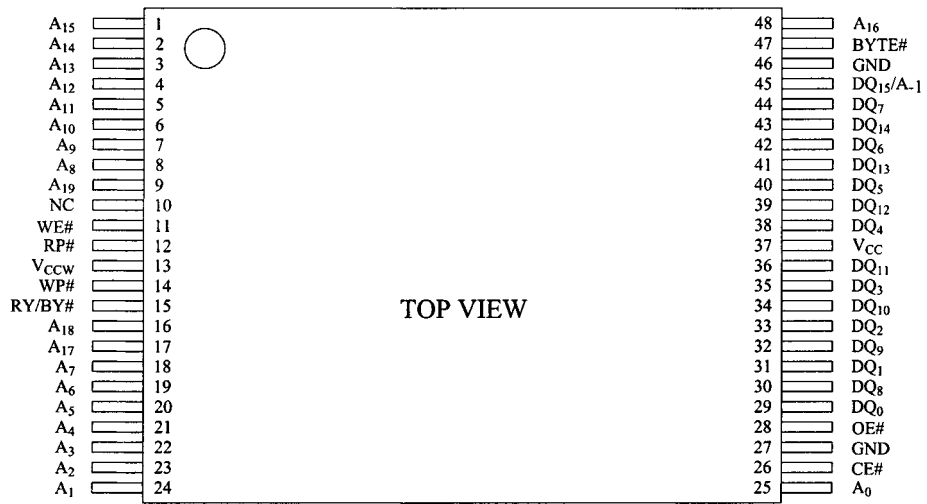

SN74LV573APWR (IC818)

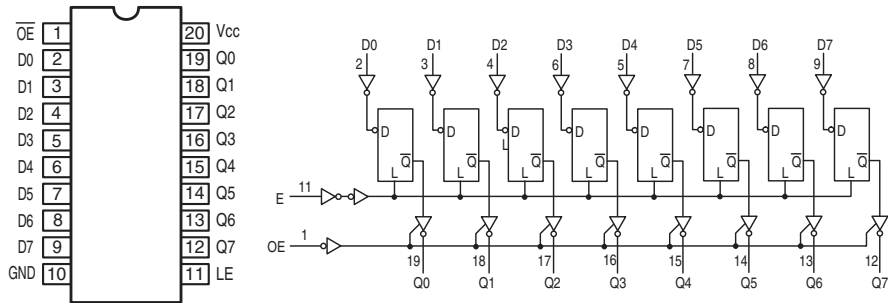

MM74HCT00MTCX (IC814,815)

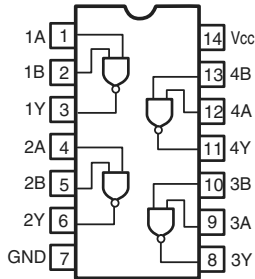

SN74LV14APWR (IC817)

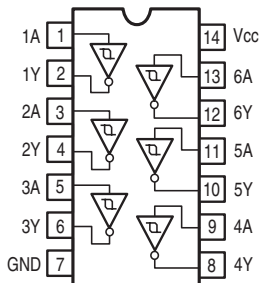

ADV7180BSTZ (IC1018 : for AVR1708/688 model)

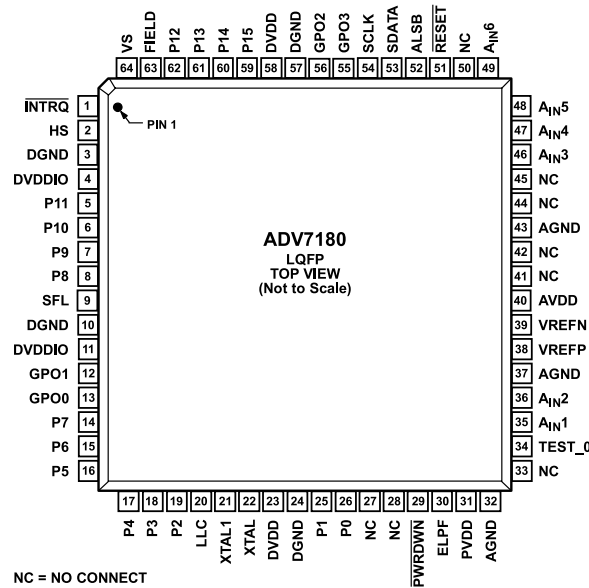

Pin No.	Mnemonic	Type	Function
3, 10, 24, 57	DGND	G	Digital Ground.
32, 37, 43	AGND	G	Analog Ground.
4, 11	DVDDIO	P	Digital I/O Supply Voltage (3.3 V).
23, 58	DVDD	P	Digital Supply Voltage (1.8 V).
40	AVDD	P	Analog Supply Voltage (1.8 V).
31	PVDD	P	PLL Supply Voltage (1.8 V).
38	VREFP	O	Internal Voltage Reference Output.
39	VREFN	O	Internal Voltage Reference Output.
35, 36, 46 to 49	AIN1 to AIN6	I	Analog Video Input Channels.
27, 28, 33, 41, 42, 44, 45, 50,	NC		No Connect Pins. These pins are not connected internally.
5 to 8, 14 to 19, 25, 26, 59 to 62	P11 to P8, P7 to P2, P1, P0, P15 to P12	O	Video Pixel Output Port.
2	HS	O	Horizontal Synchronization Output Signal.
64	VS	O	Vertical Synchronization Output Signal.
63	FIELD	O	Field Synchronization Output Signal.
1	INTRQ	O	Interrupt Request Output. Interrupt occurs when certain signals are detected on the input video.
53	SDATA	I/O	I ² C Port Serial Data Input/Output Pin.
54	SCLK	I	I ² C Port Serial Clock Input. Maximum clock rate of 400 kHz.
52	ALSB	I	This pin selects the I ² C address for the ADV7180. For ALSB set to Logic 0, the address selected for a write is 0x40; for ALSB set to logic high, the address selected is 0x42.
29	PWRDWN	I	A logic low on this pin places the ADV7180 in power-down mode.
30	ELPF	I	The recommended external loop filter must be connected to the ELPF pin.
51	RESET	I	System Reset Input. Active low. A minimum low reset pulse width of 5 ms is required to reset the ADV7180 circuitry.

Pin No.	Mnemonic	Type	Function
9	SFL	O	Subcarrier Frequency Lock. This pin contains a serial output stream that can be used to lock the subcarrier frequency when this decoder is connected to any Analog Devices, Inc., digital video encoder.
20	LLC	O	This is a line-locked output clock for the pixel data output by the ADV7180. It is nominally 27 MHz, but varies up or down according to video line length.
21	XTAL1	O	This pin should be connected to the 28.6363 MHz crystal or left as a no connect if an external 1.8 V, 28.6363 MHz clock oscillator source is used to clock the ADV7180. In crystal mode, the crystal must be a fundamental crystal.
22	XTAL	I	This is the input pin for the 28.6363 MHz crystal, or this pin can be overdriven by an external 1.8 V, 28.6363 MHz clock oscillator source. In crystal mode, the crystal must be a fundamental crystal.
12, 13, 55, 56	GPO0 to GPO3	O	General-Purpose Outputs. These pins can be configured via I ² C to allow control of external devices.
34	TEST_0	I	This pin must be tied to DGND.

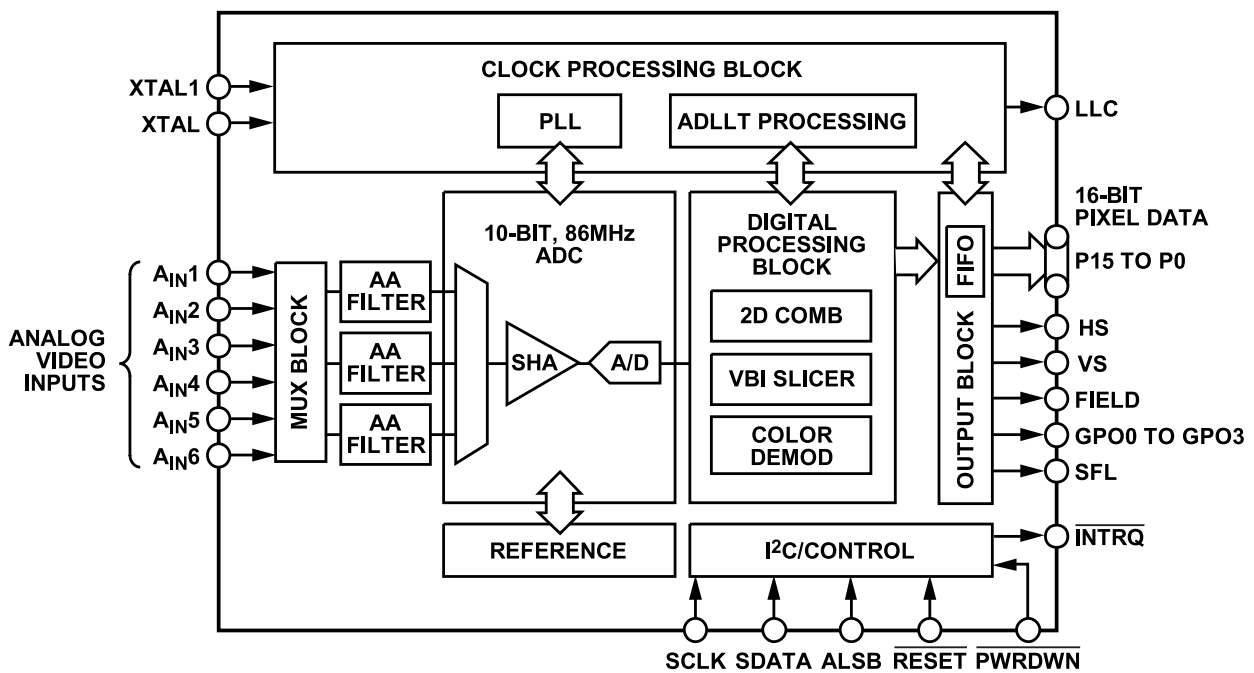

ADV7172KSTZ (IC1019 : for AVR1708/688 model)

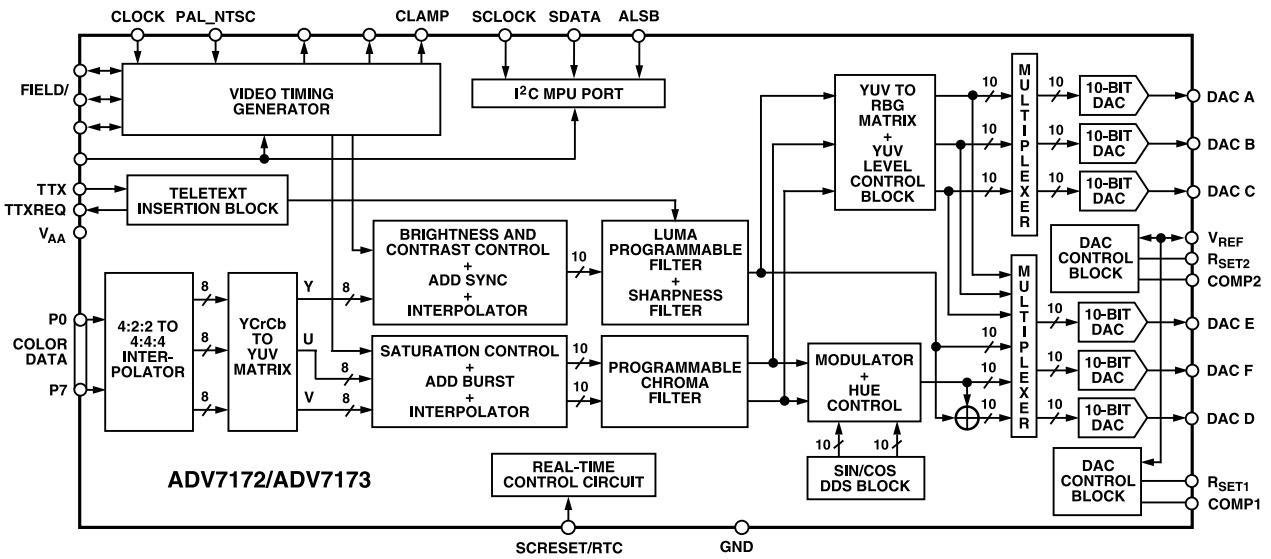
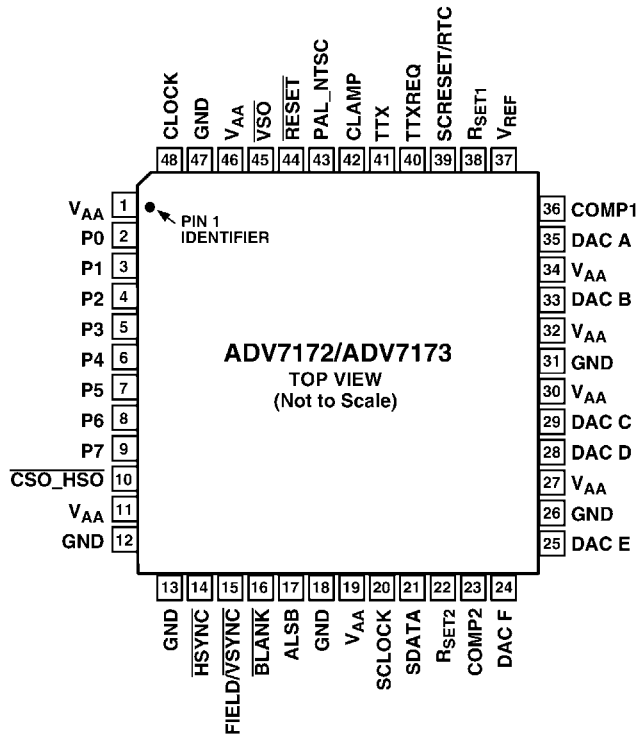

PIN FUNCTION DESCRIPTION

Mnemonic	Input/Output	Function
P7–P0	I	8-Bit 4:2:2 Multiplexed YCrCb Pixel Port (P7–P0) P0 represents the LSB.
CLOCK	I	TTL Clock Input. Requires a stable 27 MHz reference clock for standard operation. Alternatively, a 24.5454 MHz (NTSC) or 29.5 MHz (PAL) can be used for square pixel operation.
$\overline{\text{HSYNC}}$	I/O	$\overline{\text{HSYNC}}$ (Modes 1 and 2) Control Signal. This pin may be configured to output (Master Mode) or as an input and accept (Slave Mode) Sync signals.
FIELD/ $\overline{\text{VSYNC}}$	I/O	Dual Function FIELD (Mode 1) and $\overline{\text{VSYNC}}$ (Mode 2) Control Signal. This pin may be configured to output (Master Mode) or as an input (Slave Mode) and accept these control signals.
$\overline{\text{BLANK}}$	I/O	Video Blanking Control Signal. The pixel inputs are ignored when this is Logic Level “0.” This signal is optional.
SCRESET/RTC	I	This pin can be configured as an input by setting MR42 and MR41 of Mode Register 4. It can be configured as a subcarrier reset pin, in which case a low-to-high transition on this pin will reset the subcarrier phase to Field 0. Alternatively it may be configured as a Real-Time Control (RTC) Input.
V_{REF}	I/O	Voltage Reference Input for DACs or Voltage Reference Output (1.235 V).
R_{SET1}	I	A 150 Ω resistor connected from this pin to GND is used to control full-scale amplitudes of the Video Signals from DACs A, B, and C (the “large” DACs).
R_{SET2}	I	A 600 Ω resistor connected from this pin to GND is used to control full-scale amplitudes of the Video Signals from DACs D, E, and F (the “small” DACs).
COMP1	O	Compensation Pin for DACs A, B, and C. Connect a 0.1 μF Capacitor from COMP to V_{AA} . For Optimum Dynamic Performance in Low Power Mode, the value of the COMP1 capacitor can be lowered to as low as 2.2 nF.
COMP2	O	Compensation Pin for DACs D, E, and F. Connect a 0.1 μF Capacitor from COMP to V_{AA} .
DAC A	O	GREEN/Composite/Y Analog Output. This DAC is capable of providing 34.66 mA output.
DAC B	O	BLUE/S-Video Y/U Analog Output. This DAC is capable of providing 34.66 mA output.
DAC C	O	RED/S-Video C/V Analog Output. This DAC is capable of providing 34.66 mA output.
DAC D	O	GREEN/Composite/Y Analog Output. This DAC is capable of providing 8.66 mA output.
DAC E	O	BLUE/S-Video Y/U Analog Output. This DAC is capable of providing 8.66 mA output.
DAC F	O	RED/S-Video C/V Analog Output. This DAC is capable of providing 8.66 mA output.
SCLOCK	I	MPU Port Serial Interface Clock Input.
SDATA	I/O	MPU Port Serial Data Input/Output.
CLAMP	O	TTL Output Signal to external circuitry to enable clamping of all video signals.
PAL_NTSC	I	Input signal to select PAL or NTSC mode of operation, pin set to Logic “1” selects PAL.
$\overline{\text{VSO}}$	O	$\overline{\text{VSO}}$ TTL Output Sync Signal.
$\overline{\text{CSO_HSO}}$	O	Dual Function $\overline{\text{CSO}}$ or $\overline{\text{HSO}}$ TTL Output Sync Signal.
ALSB	I	TTL Address Input. This signal sets up the LSB of the MPU address.
$\overline{\text{RESET}}$	I	The input resets the on-chip timing generator and sets the ADV7172/ADV7173 into default mode. This is NTSC operation, Timing Slave Mode 0, DACs A, B, and C powered OFF, DACs D, E, and F powered ON, Composite and S-Video out.
TTX	I	Teletext Data Input Pin.
TTXREQ	O	Teletext Data Request output signal used to control teletext data transfer.
V_{AA}	P	Power Supply (3 V to 5 V).
GND	G	Ground Pin.

Sil9185 (IC01)

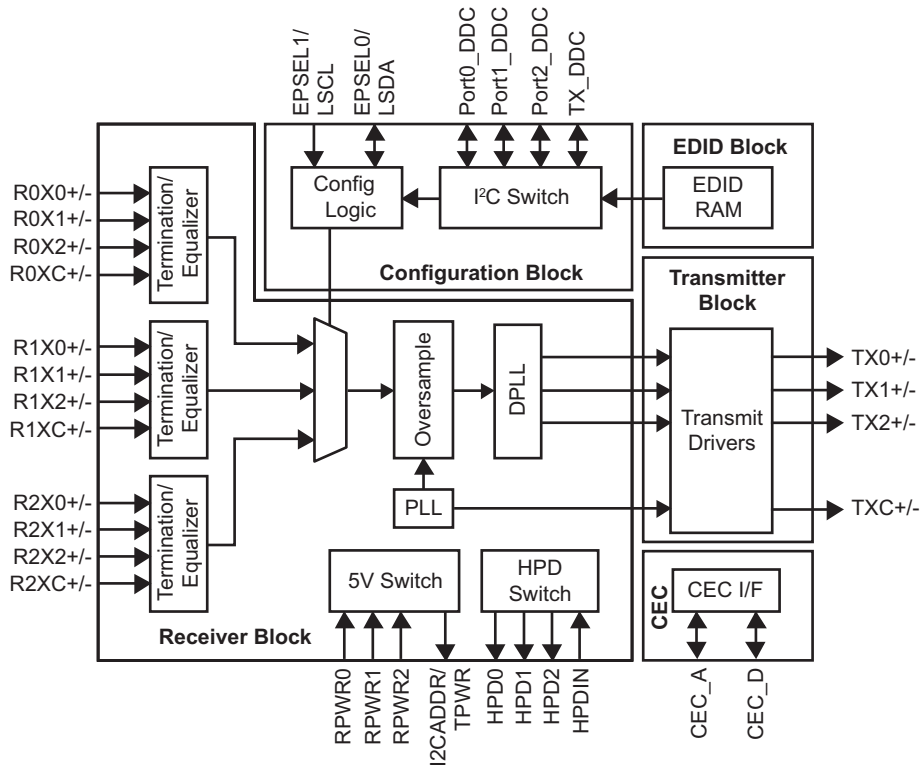
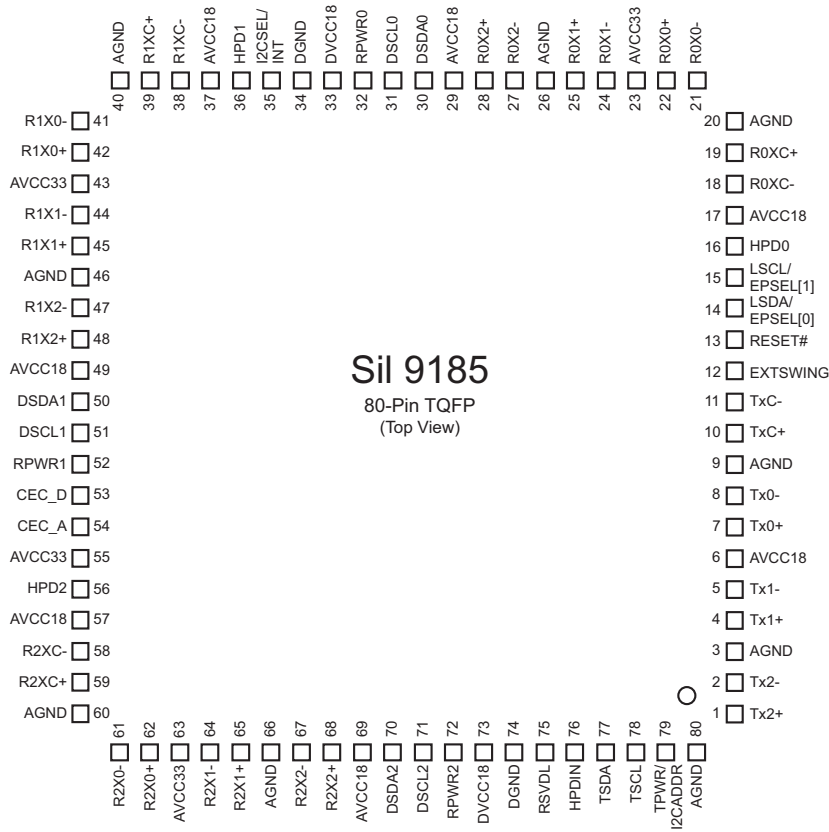

2. FL DISPLAY

HNA-16SM13T (FL301)

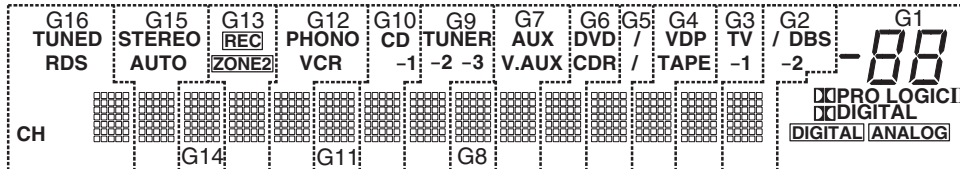
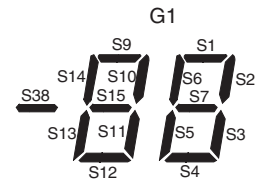
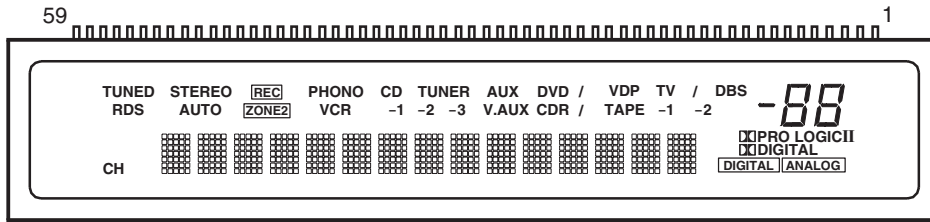

G2-G16



Pin Assignment

PIN NO.	1	2	3	4	5	6	7	8	9	10	11	12	13	14	15	16	17	18	19	20
CONNECTION	F1	F1	NP	S1	S2	S3	S4	S5	S6	S7	S8	S9	S10	S11	S12	S13	S14	S15	S16	S17
PIN NO.	21	22	23	24	25	26	27	28	29	30	31	32	33	34	35	36	37	38	39	40
CONNECTION	S18	S19	S20	S21	S22	S23	S24	S25	S26	S27	S28	S29	S30	S31	S32	S33	S34	S35	S36	S37
PIN NO.	41	42	43	44	45	46	47	48	49	50	51	52	53	54	55	56	57	58	59	
CONNECTION	S38	G16	G15	G14	G13	G12	G11	G10	G9	G8	G7	G6	G5	G4	G3	G2	G1	F2	F2	

F1, F2 : Filament
G1-G16: Grid
S1-S38 : Anode

Anode & Grid Assignment

	G1	G2-G16		G1	G2-G16		G1	G2-G16		G1	G2-G16
S1	S1	S1	S10	S10	S10	S19	---	S19	S28	---	S28
S2	S2	S2	S11	S11	S11	S20	---	S20	S29	---	S29
S3	S3	S3	S12	S12	S12	S21	---	S21	S30	---	S30
S4	S4	S4	S13	S13	S13	S22	---	S22	S31	---	S31
S5	S5	S5	S14	S14	S14	S23	---	S23	S32	---	S32
S6	S6	S6	S15	S15	S15	S24	---	S24	S33	---	S33
S7	S7	S7	S16	---	S16	S25	---	S25	S34	---	S34
S8	---	S8	S17	DIGITAL	S17	S26	---	S26	S35	---	S35
S9	S9	S9	S18	PRO LOGIC II	S18	S27	---	S27			

	G1	G2	G3	G4	G5	G6	G7	G8	G9	G10	G11	G12	G13	G14	G15	G16
S36	DIGITAL	/	TV	VDP	/(DVD)	DVD	AUX	---	TUNER	CD	---	PHONO	REC	---	STEREO	TUNED
S37	ANALOG	-2	-1	TAPE	/(CDR)	CDR	V.AUX	---	-2	-1	---	VCR	ZONE2	---	AUTO	RDS
S38	S38	DBS	---	---	---	---	---	---	-3	---	---	---	---	---	---	CH

PRINTED WIRING BOARDS
MAIN P.W.B. UNIT (1/2)

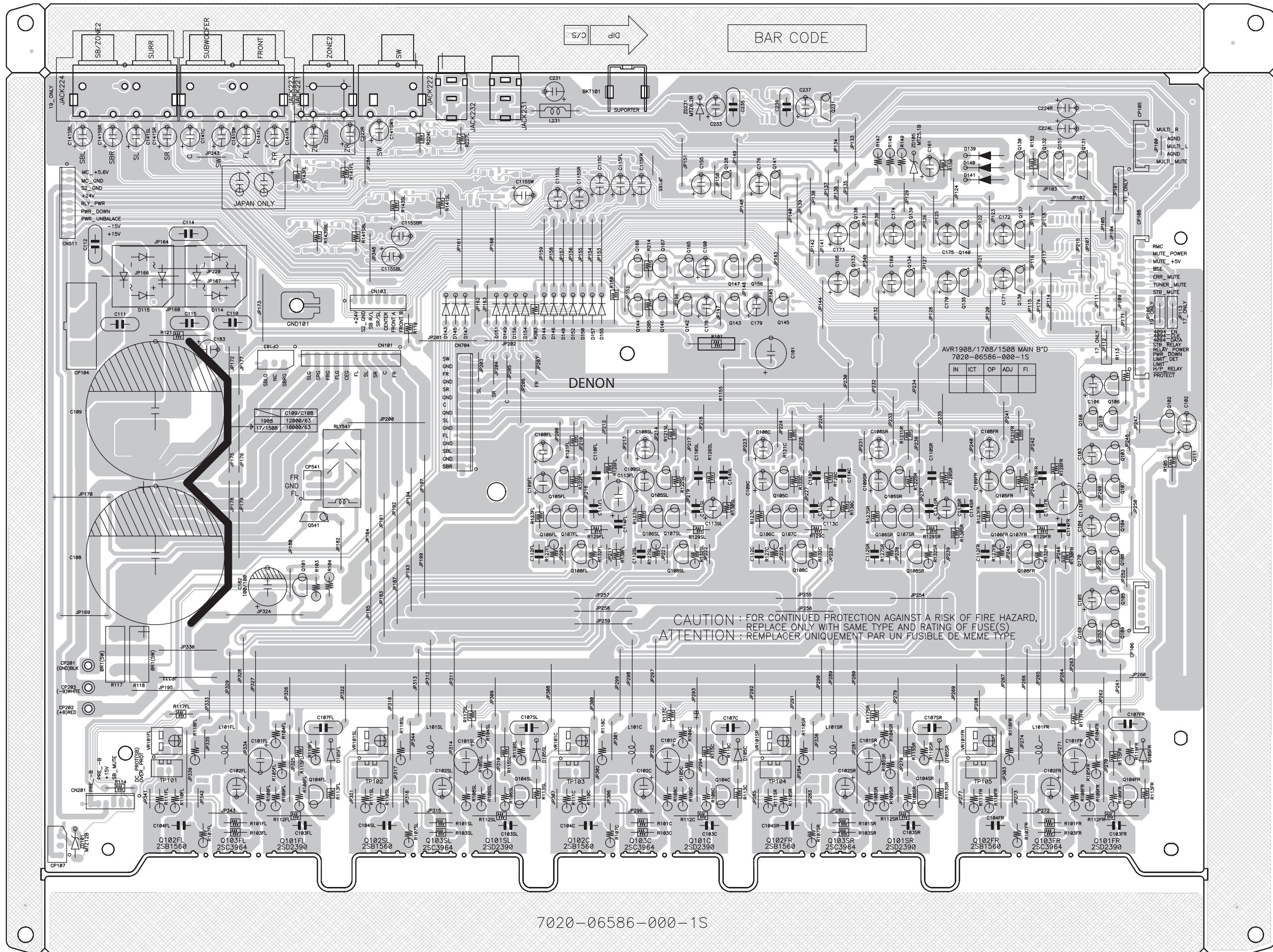

7020-06586-000-1S

COMPONENT SIDE

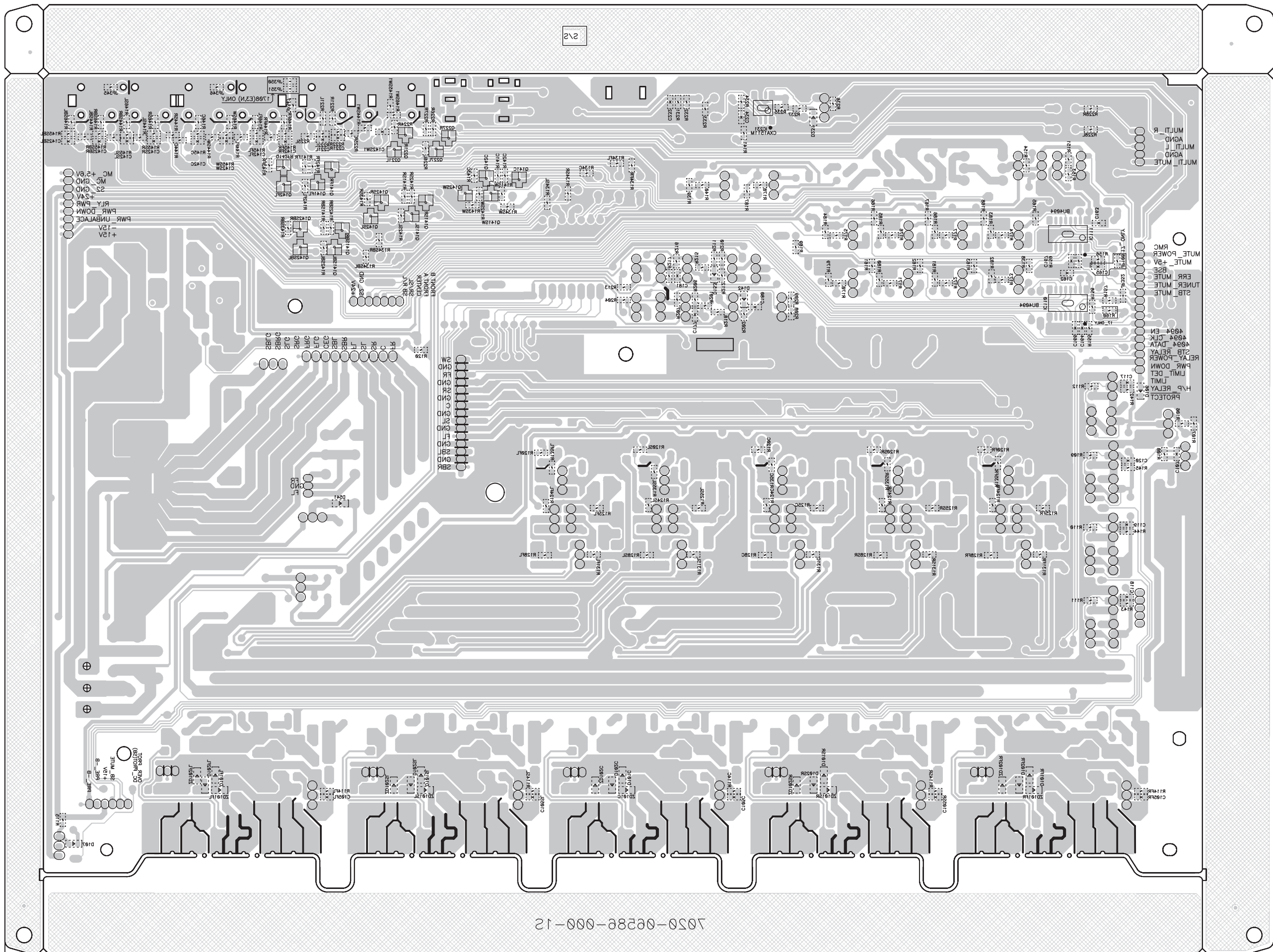

FRONT P.W.B. UNIT (1/2)

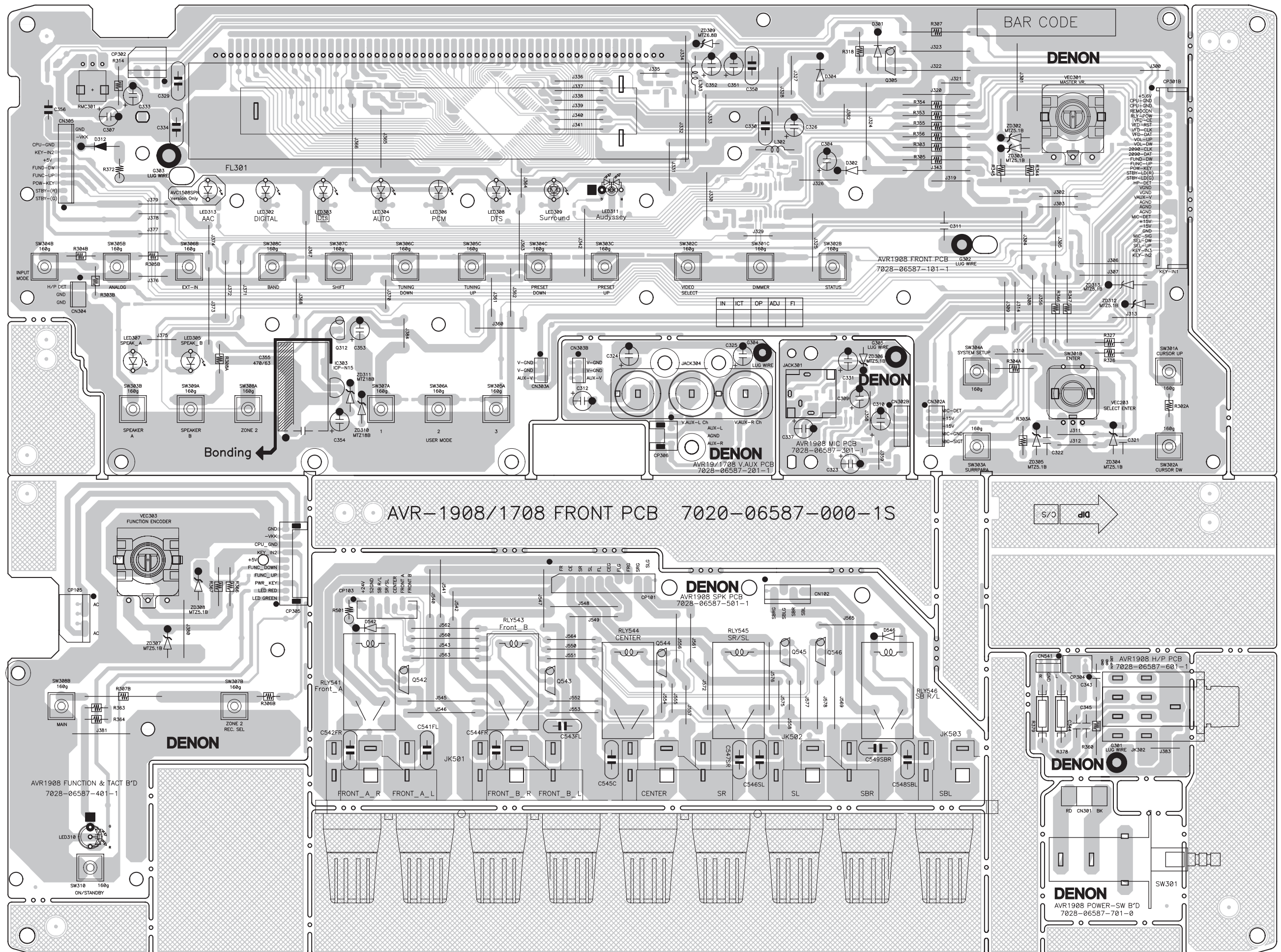

FRONT P.W.B. UNIT (2/2)

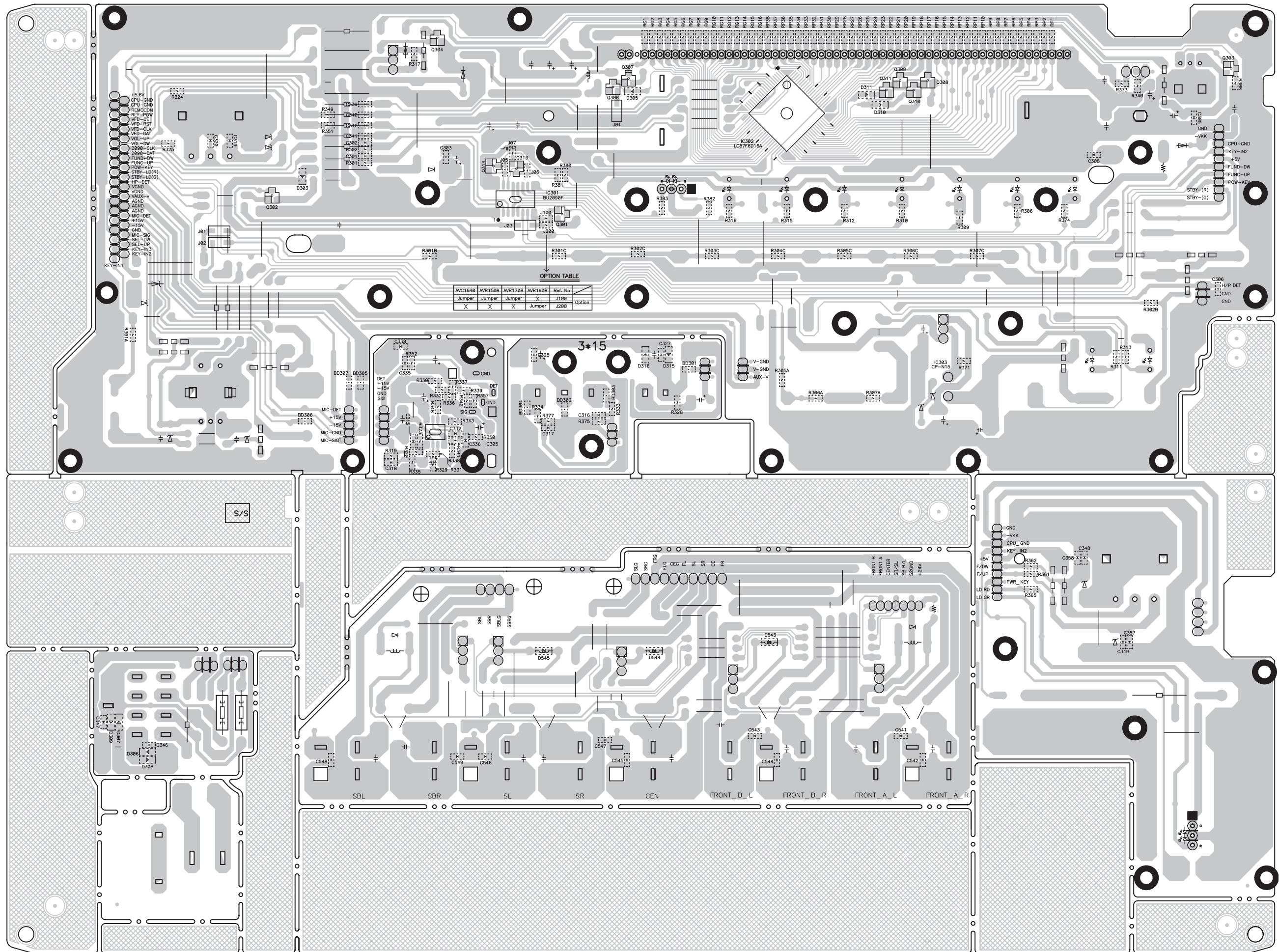

FOIL SIDE

INPUT P.W.B. UNIT

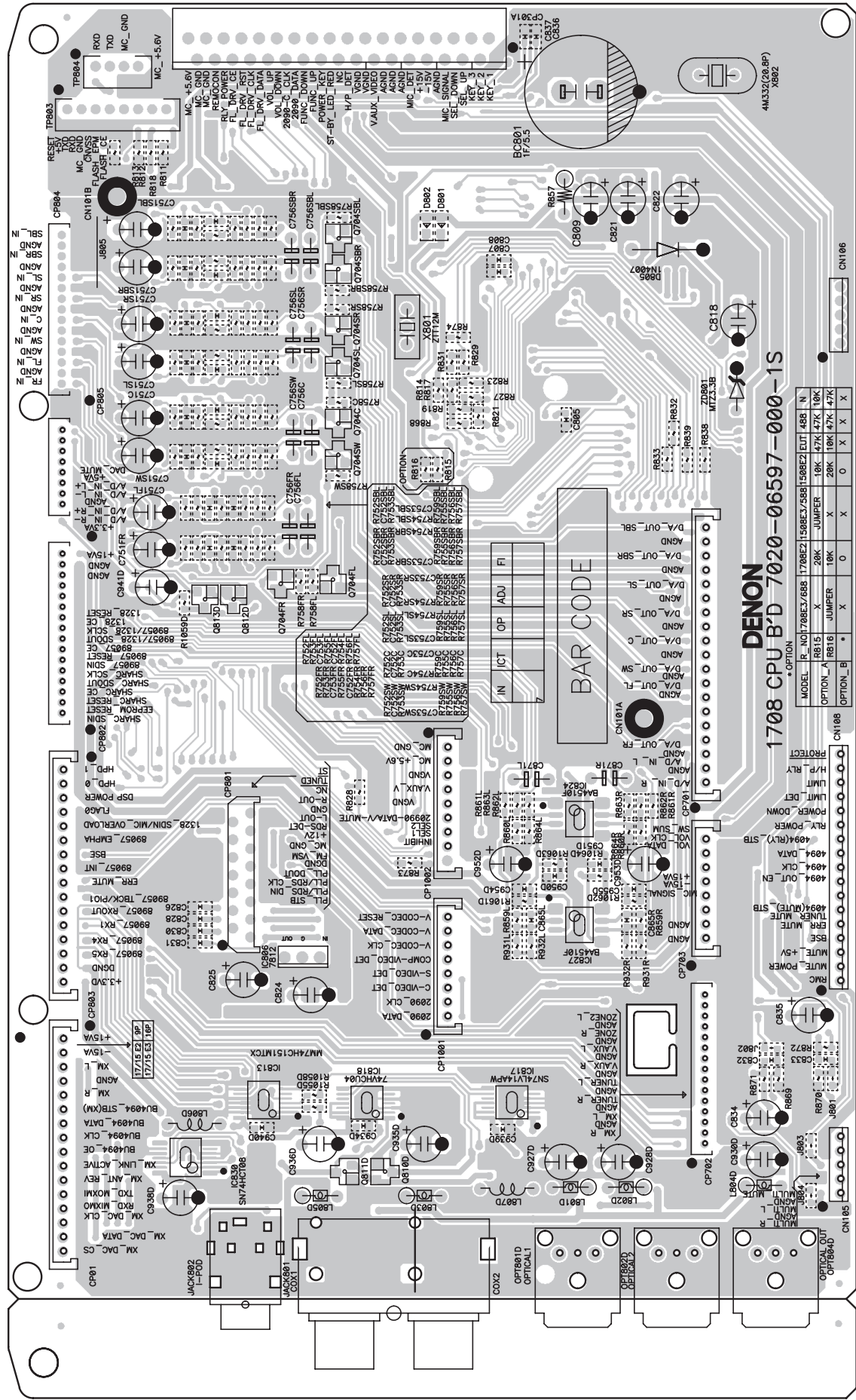

COMPONENT SIDE

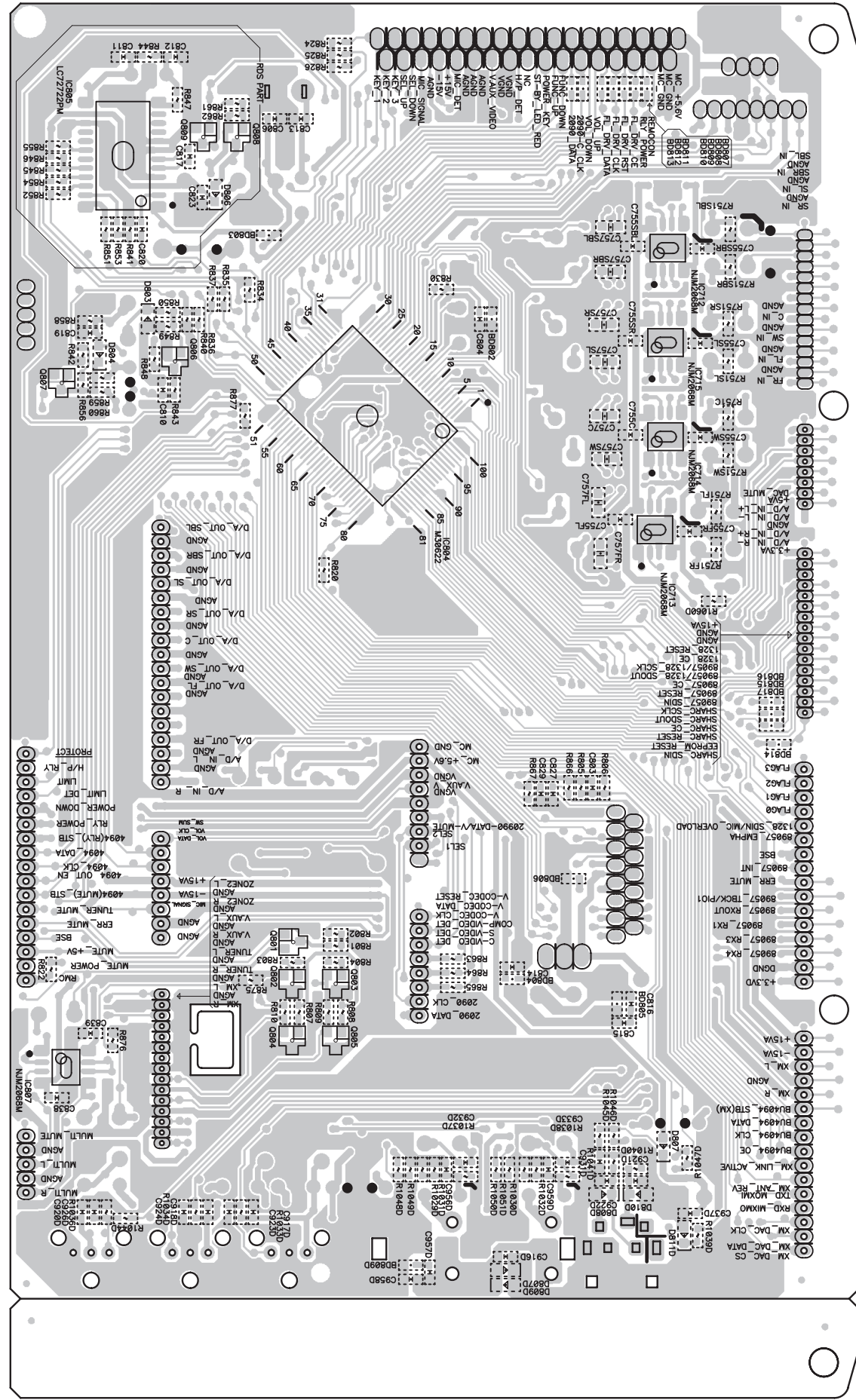

FOIL SIDE

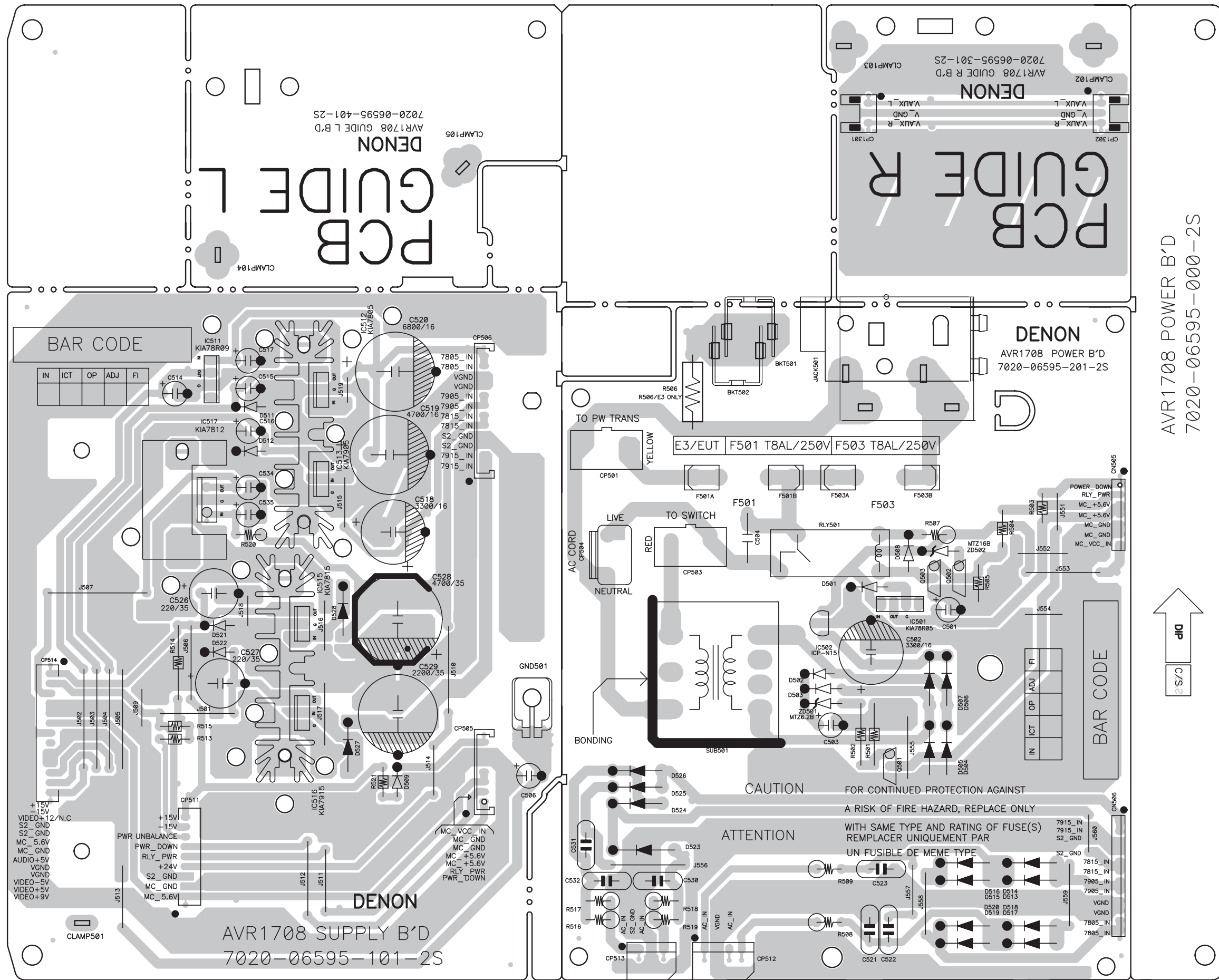

AVR1708 POWER B'D
7020-06595-000-2S

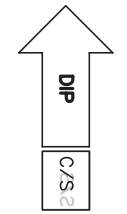

COMPONENT SIDE

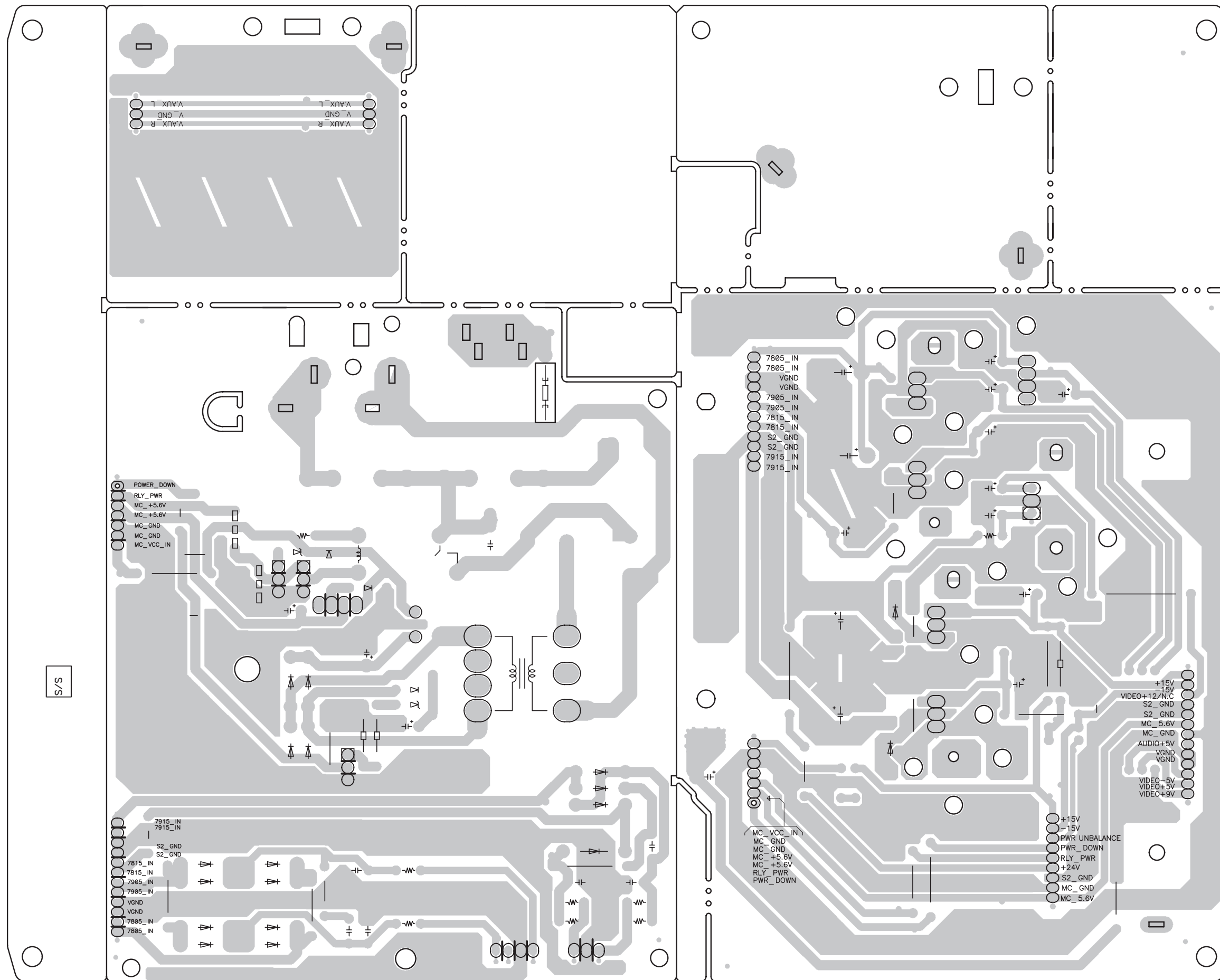

FOIL SIDE

2CH AMP P.W.B. UNIT(for AVR-1708/1508/688/588,AVC-1508 model)

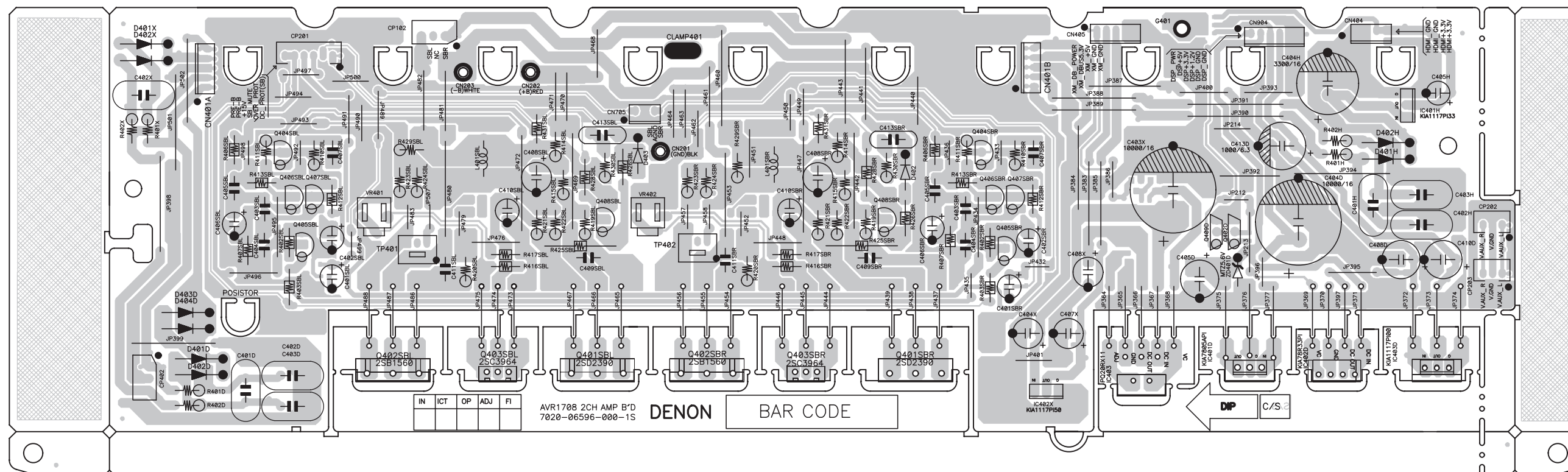

COMPONENT SIDE

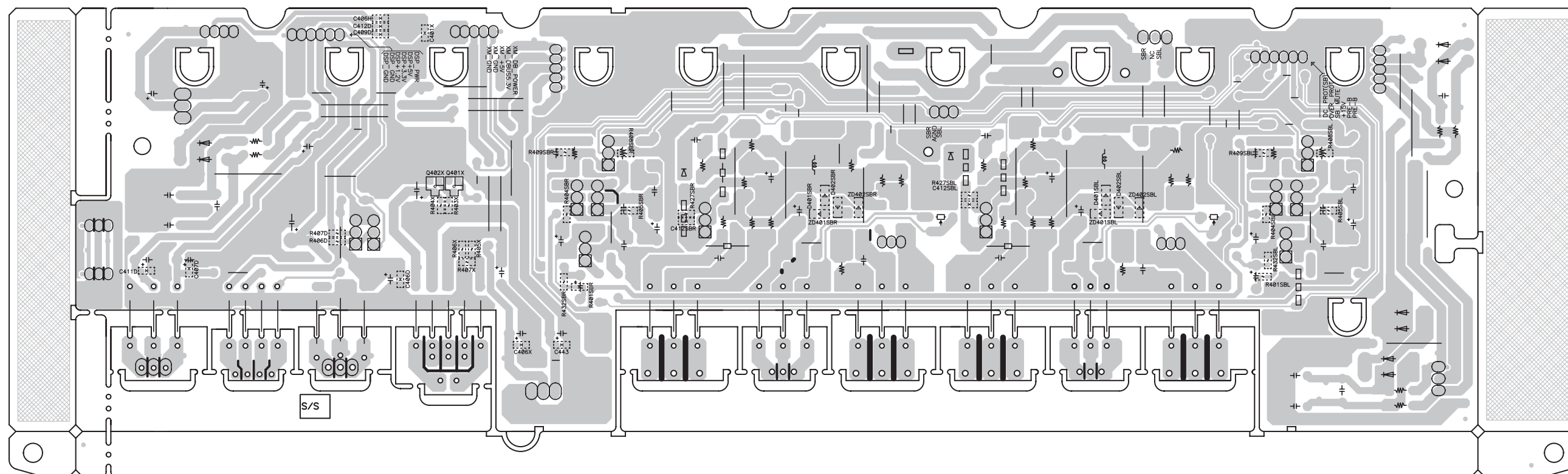

FOIL SIDE

POWER P.W.B. UNIT (for AVR-488 E3 model)

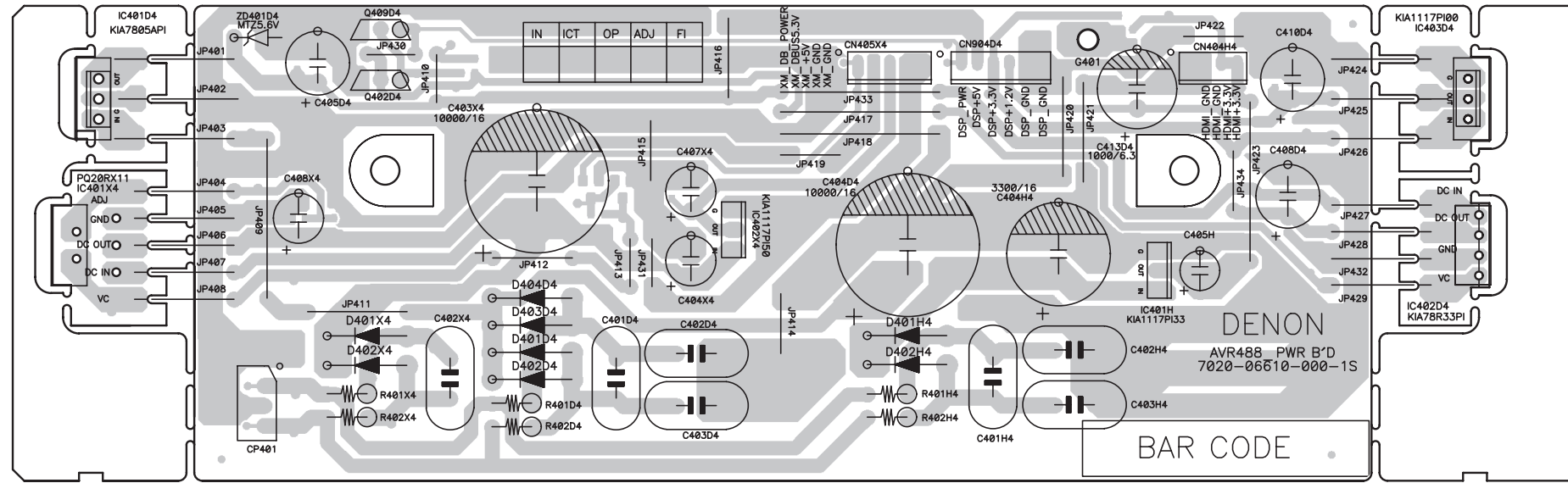

COMPONENT SIDE

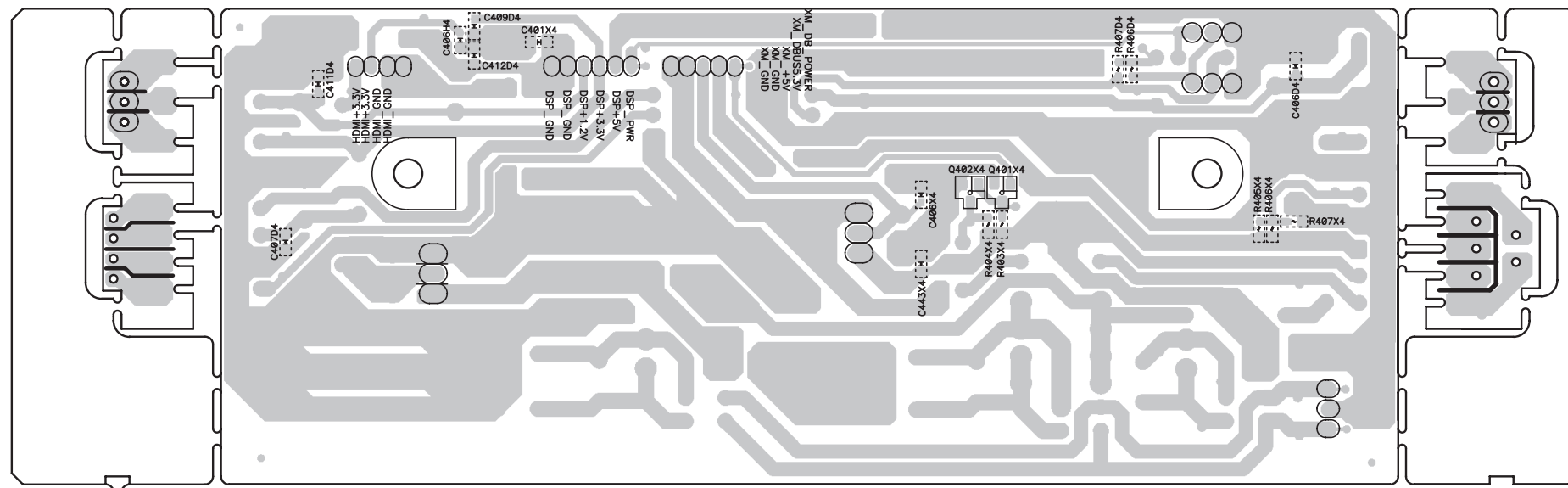

FOIL SIDE

CPU P.W.B. UNIT

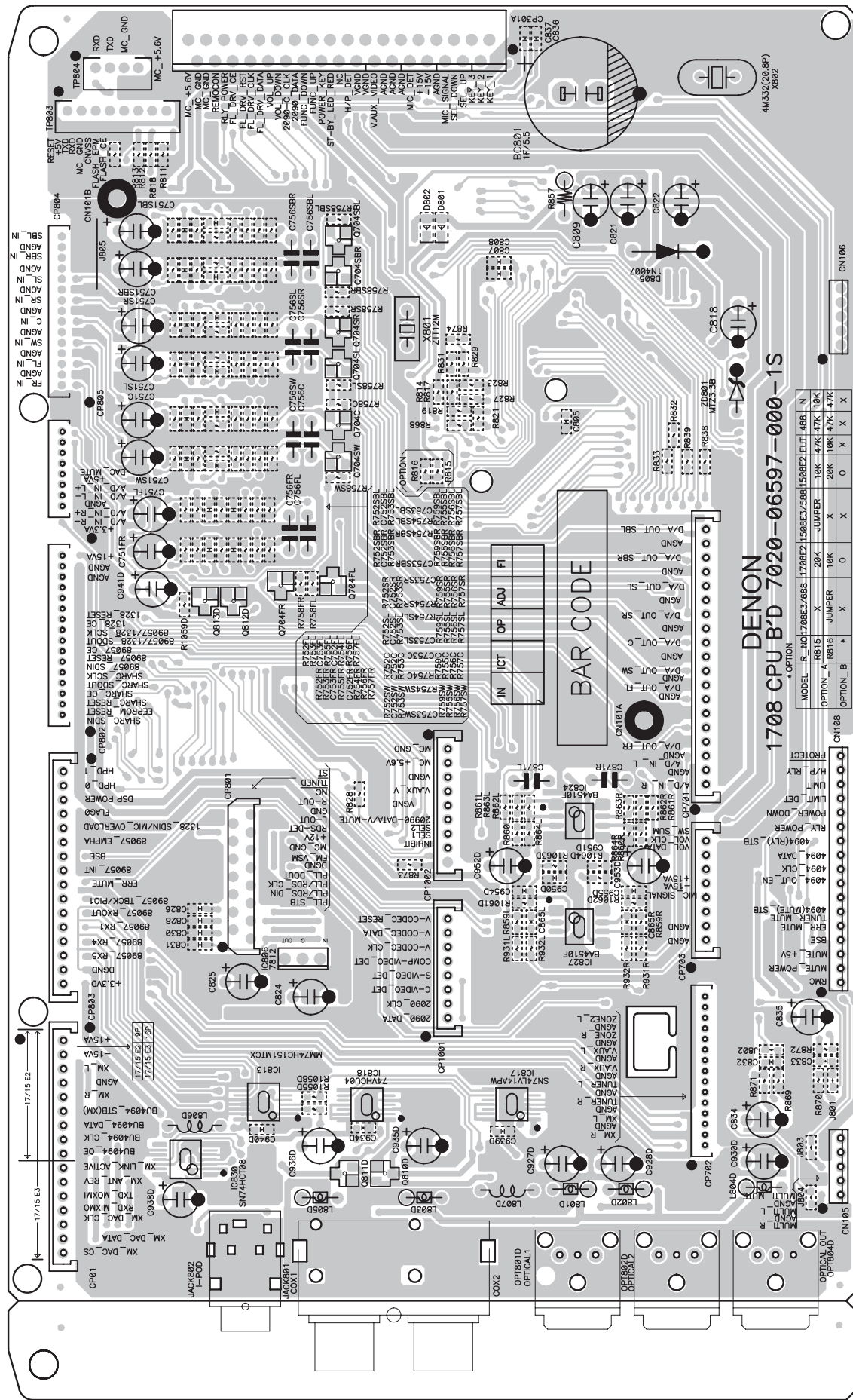

COMPONENT SIDE

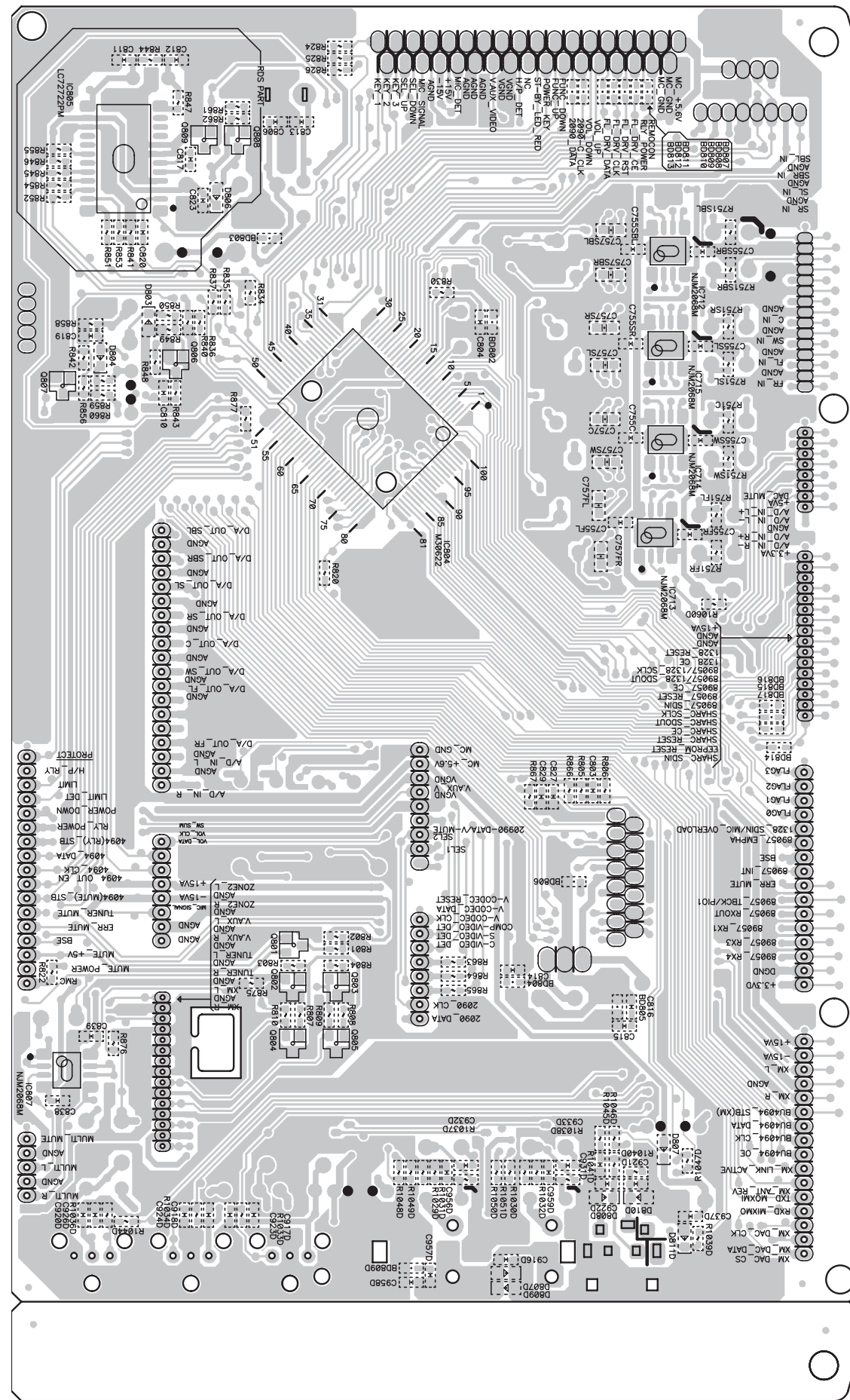

FOIL SIDE

HDMI P.W.B. UNIT

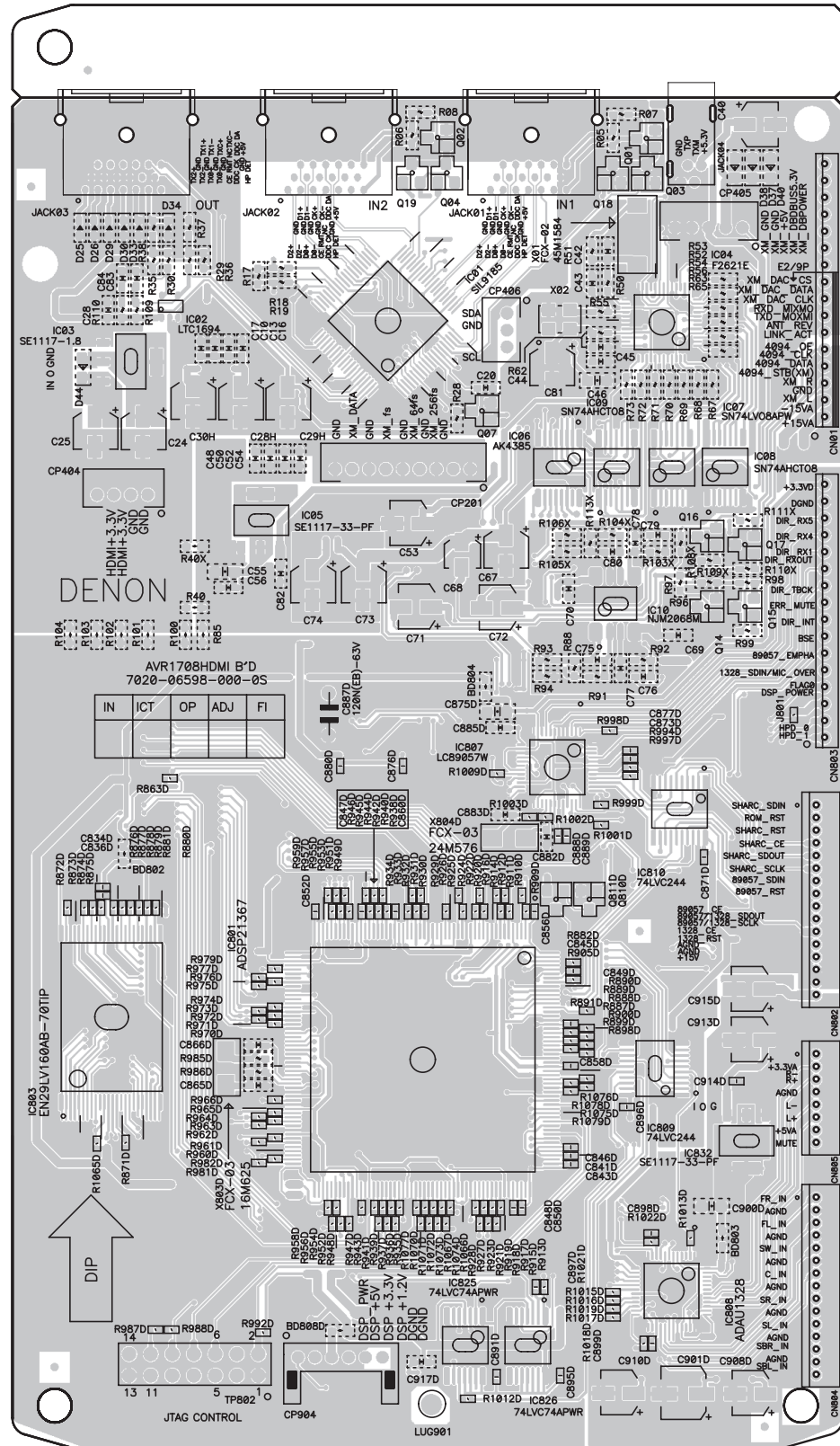

COMPONENT SIDE

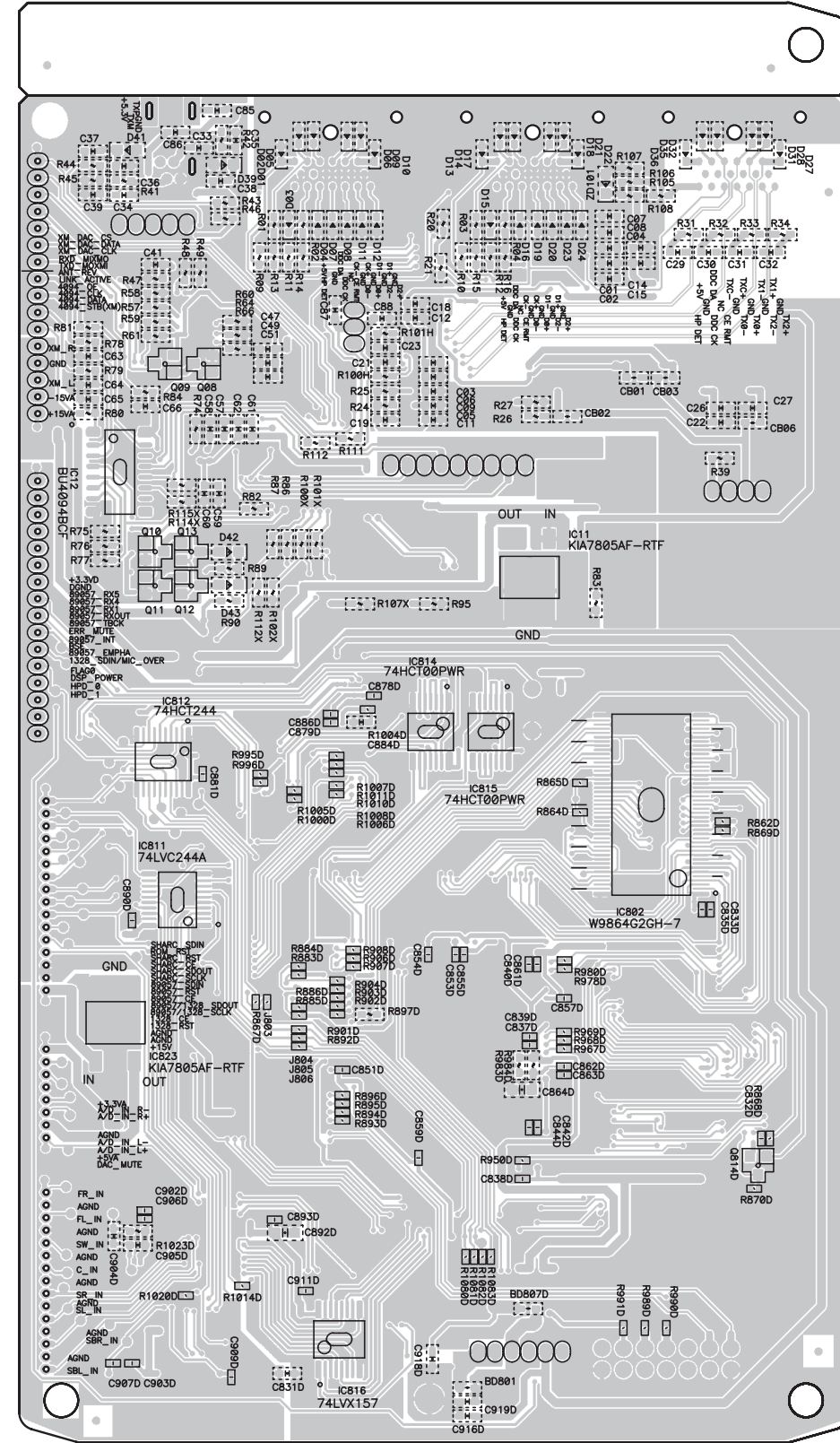

FOIL SIDE

VIDEO P.W.B. UNIT (1/2) (for AVR-1708/688 model)

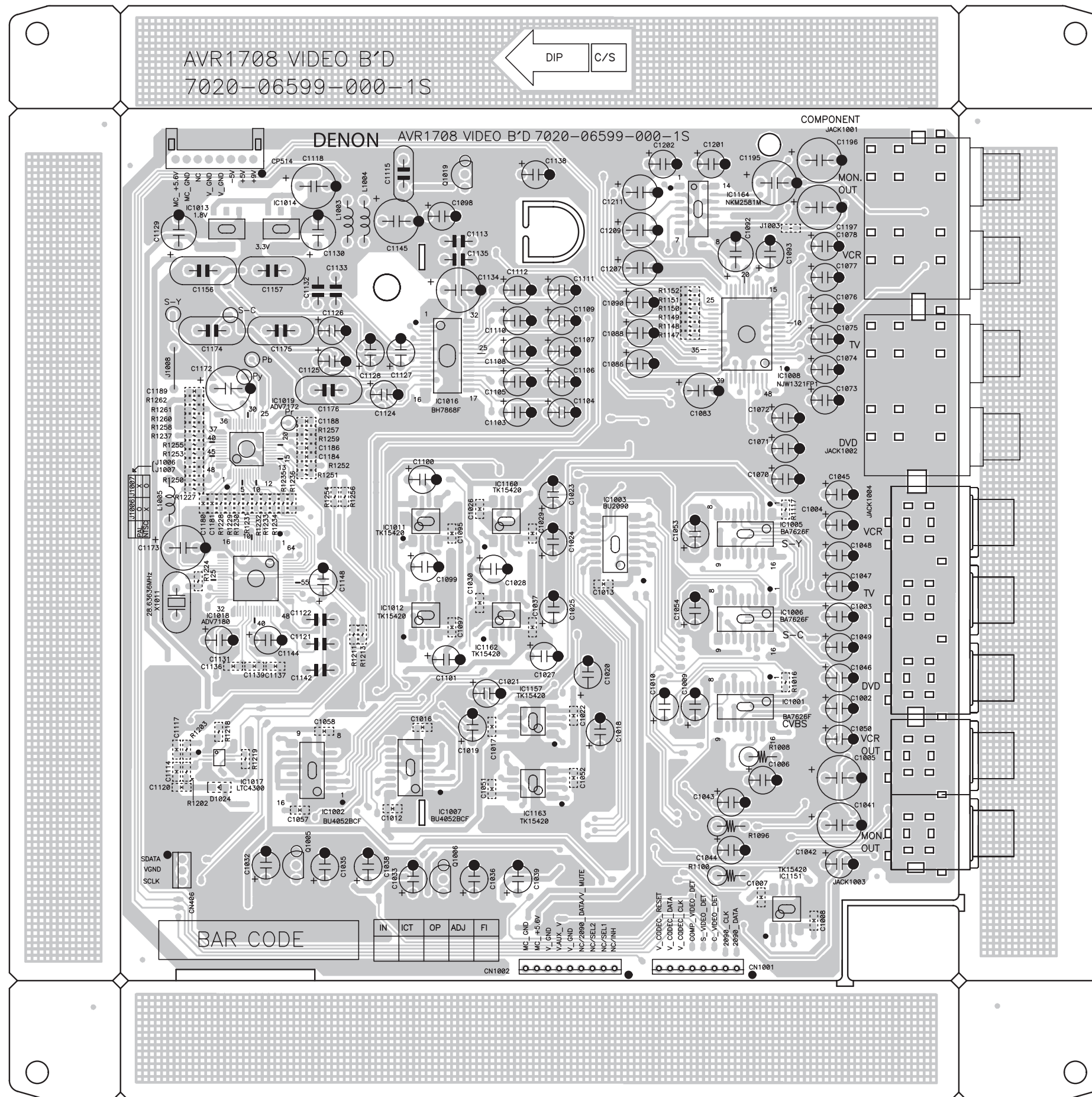

COMPONENT SIDE

VIDEO P.W.B. UNIT (2/2) (for AVR-1708/688 model)

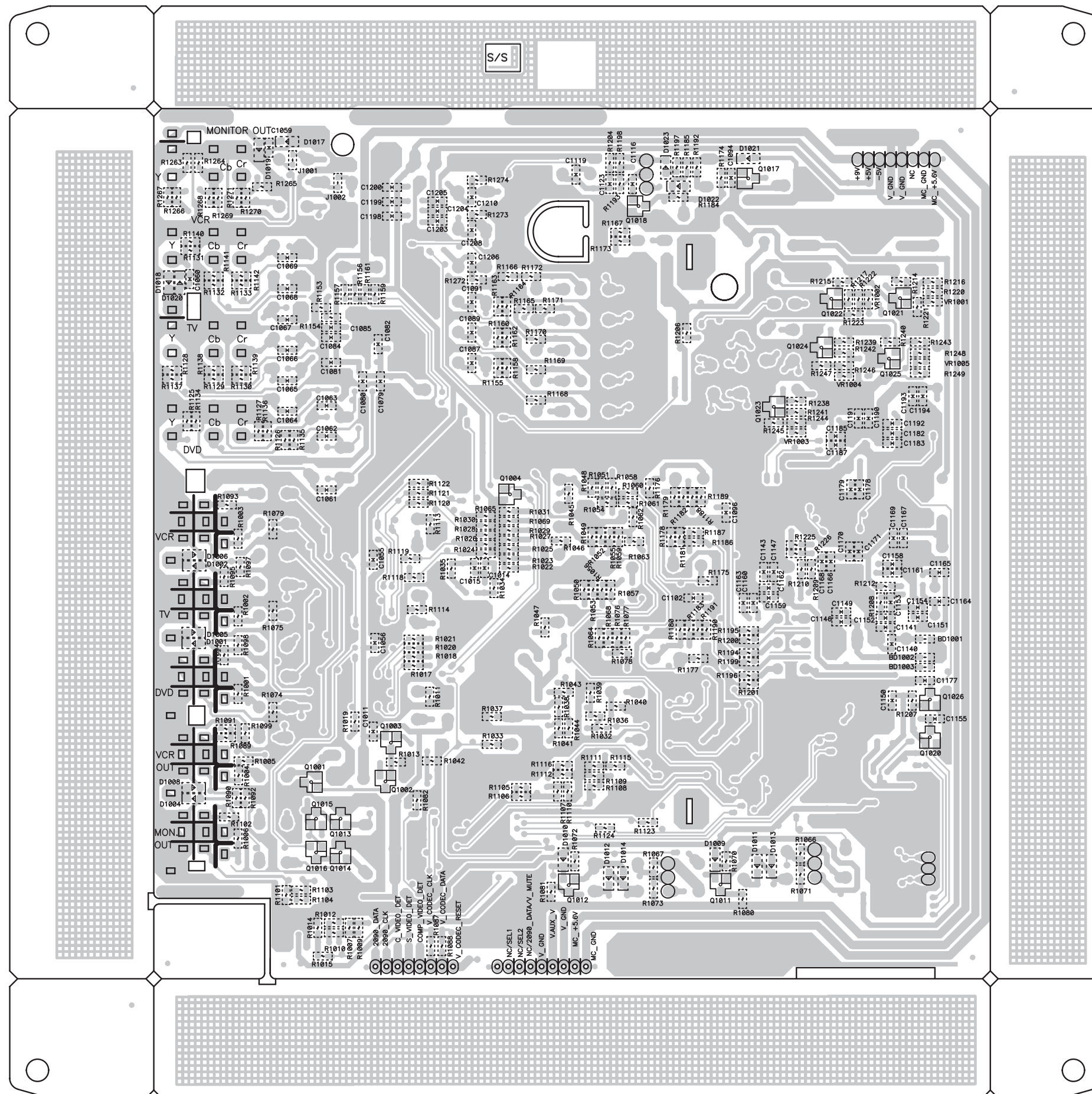

FOIL SIDE

VIDEO P.W.B. UNIT (1/2) (for AVR-1508/588/488 model)

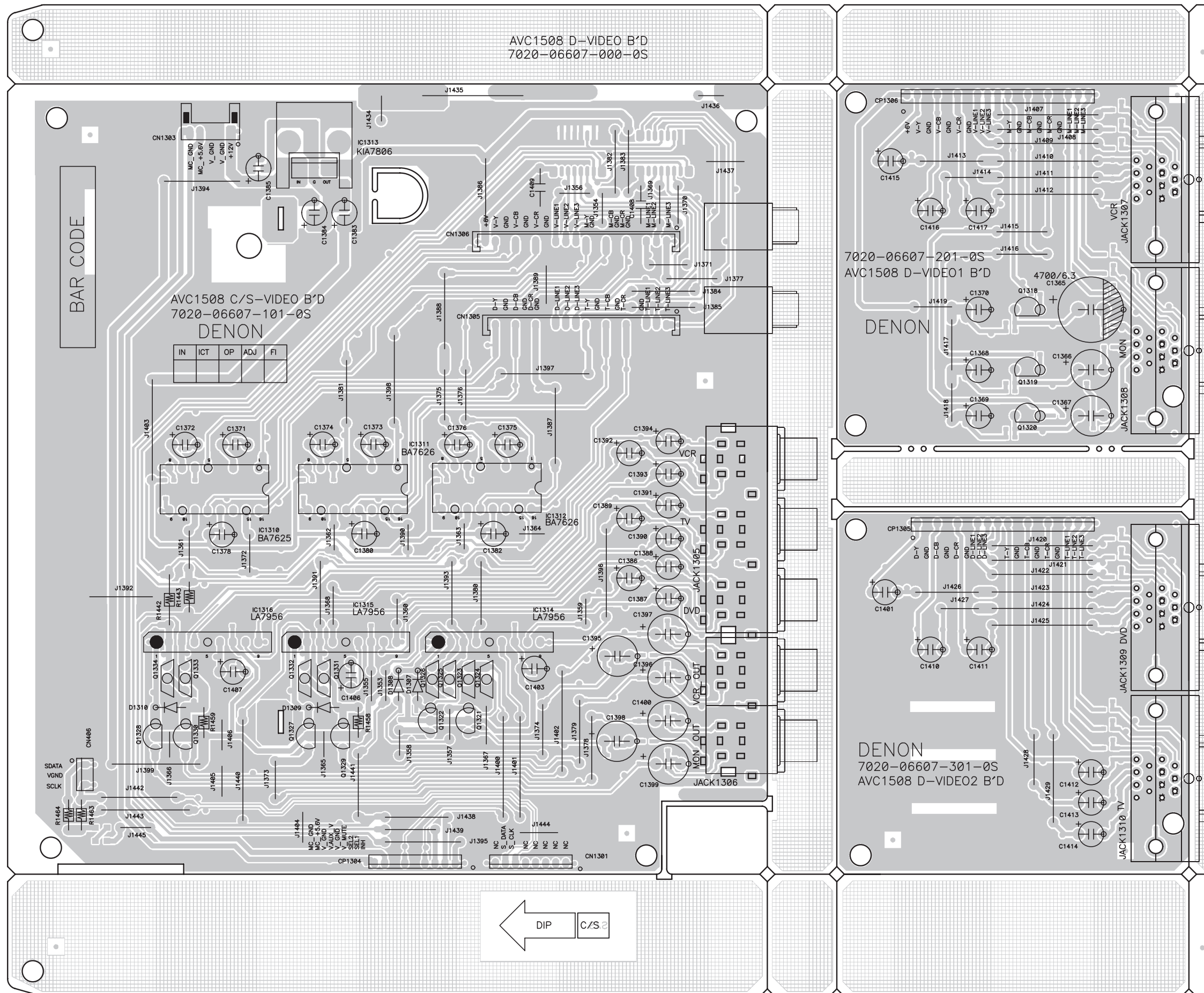

COMPONENT SIDE

VIDEO P.W.B. UNIT (2/2) (for AVR-1508/588/488 model)

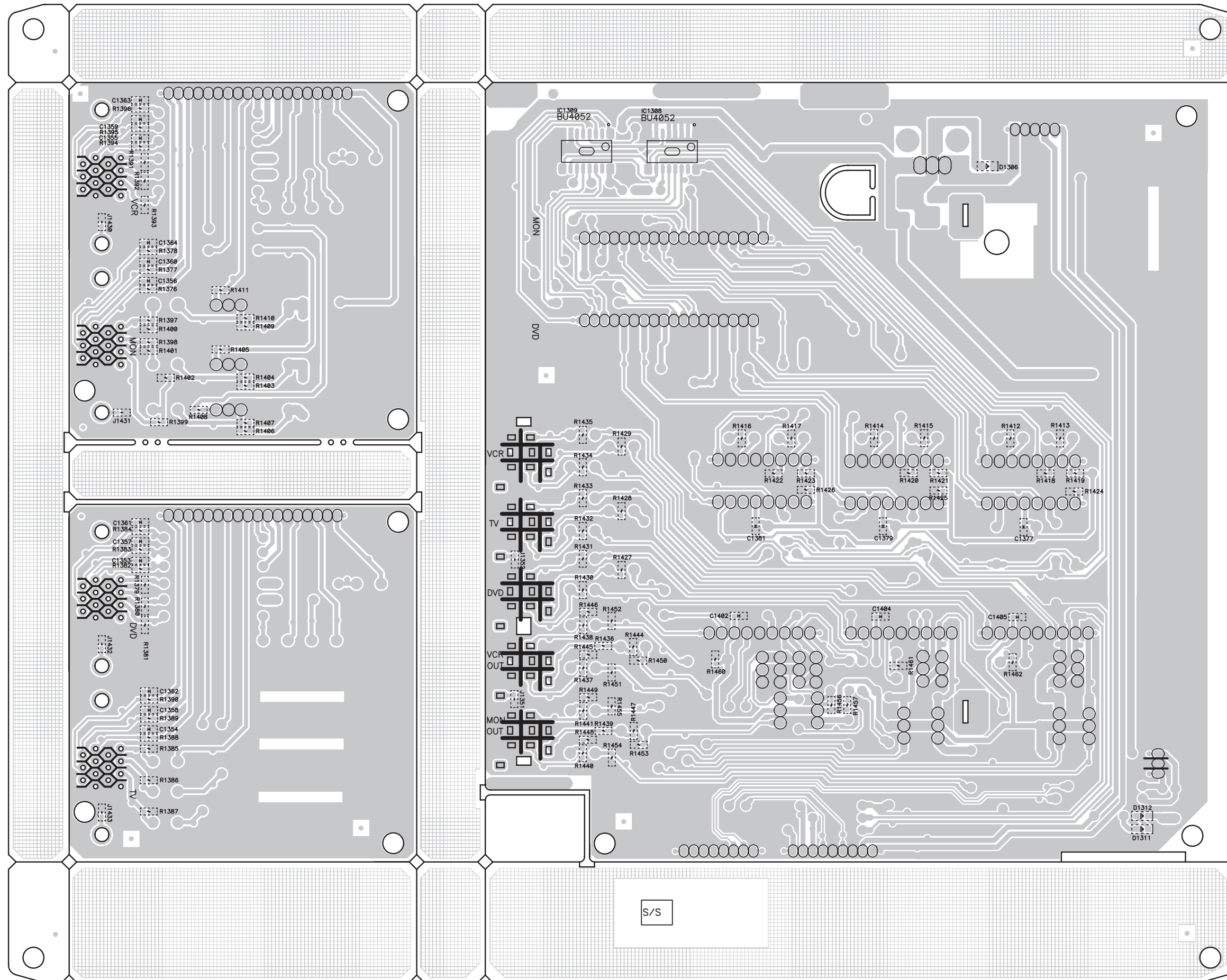

FOIL SIDE

D-VIDEO P.W.B. UNIT (1/2) (for AVC-1508 model)

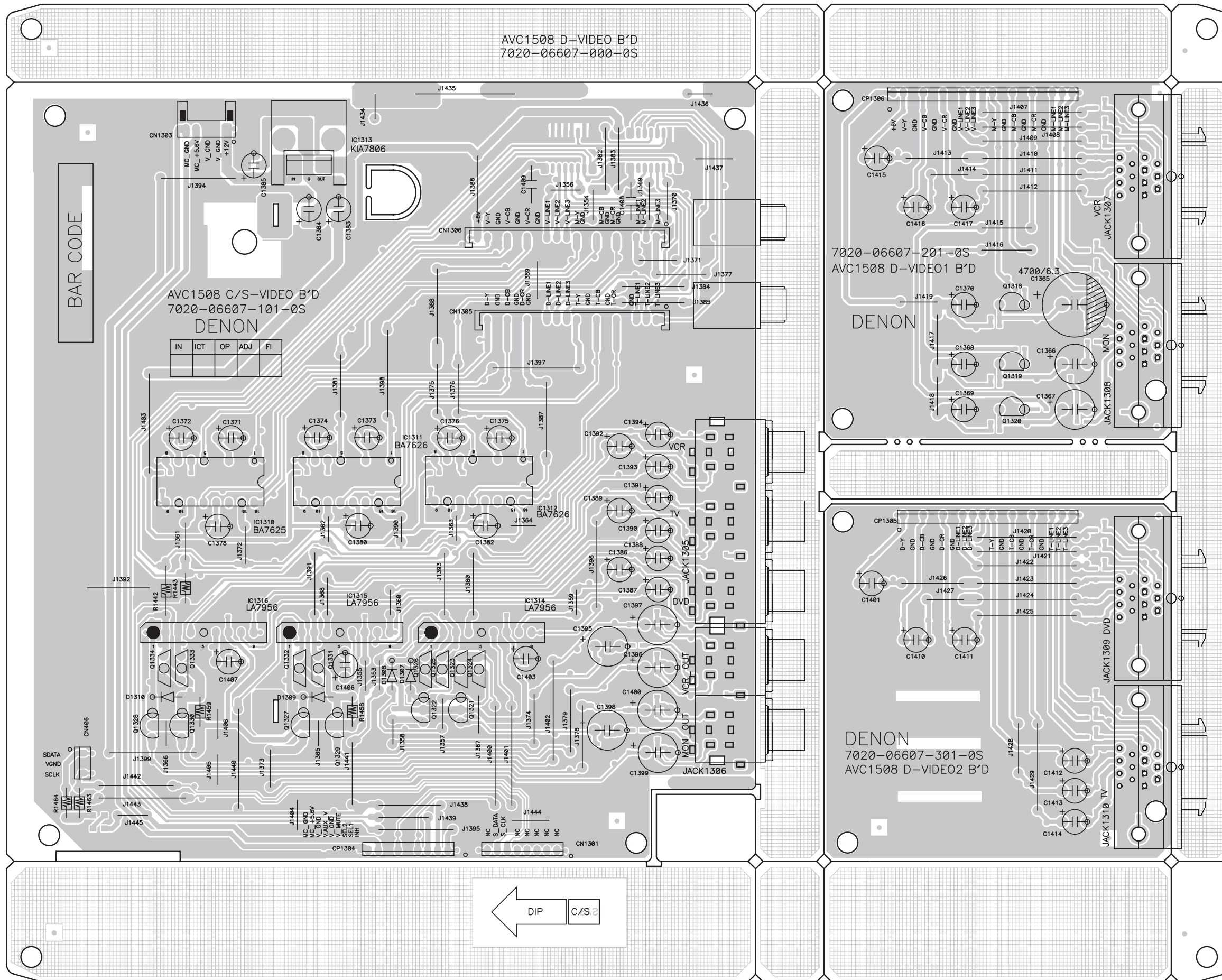

COMPONENT SIDE

D-VIDEO P.W.B. UNIT (2/2) (for AVC-1508 model)

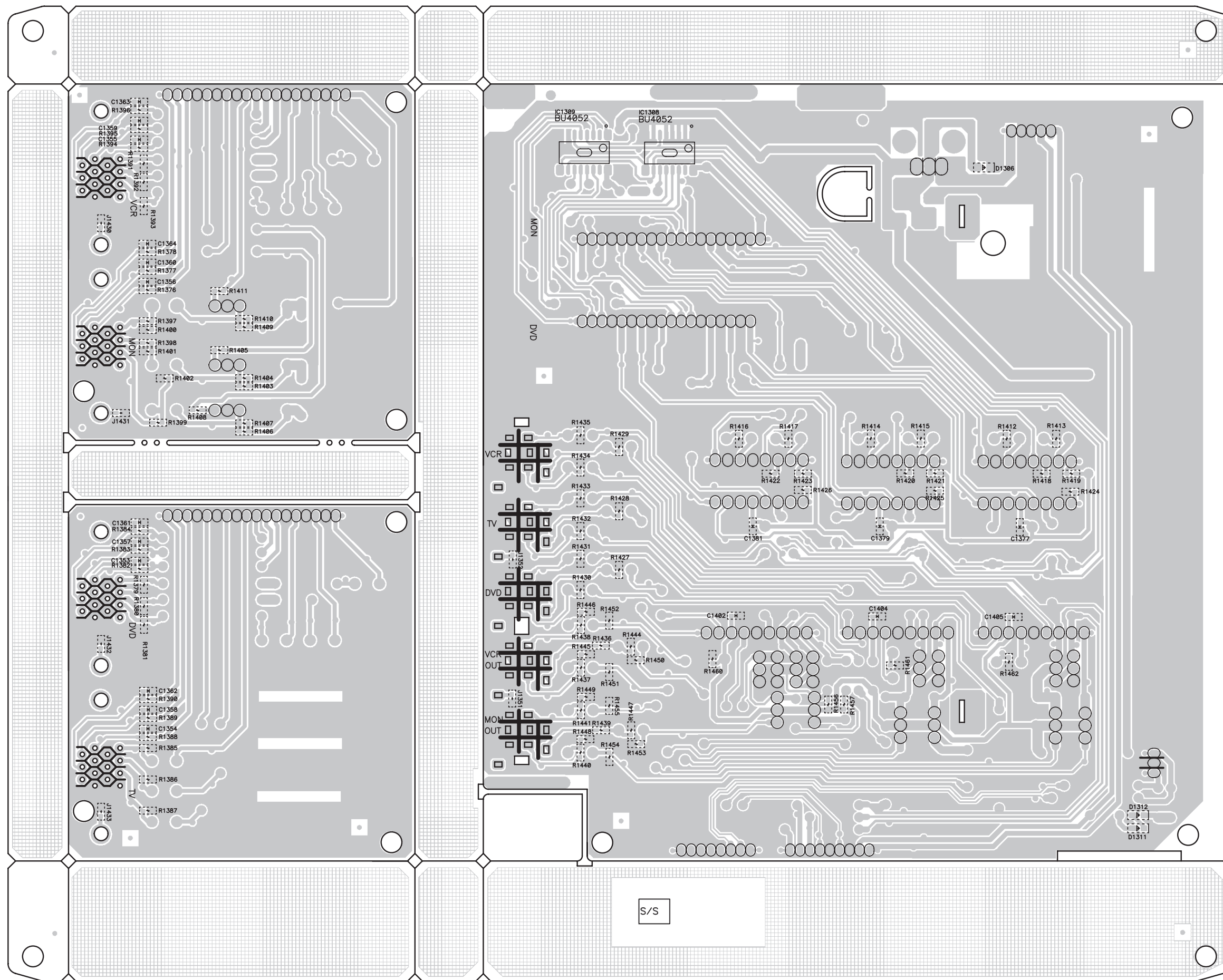

FOIL SIDE

HDMI POWER P.W.B. UNIT

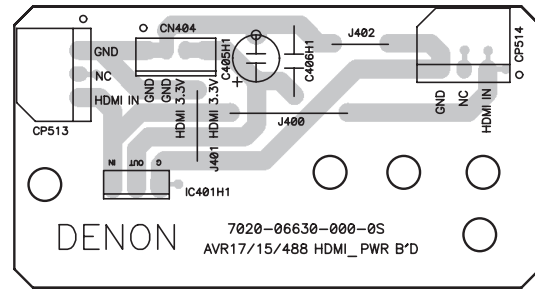

COMPONENT SIDE

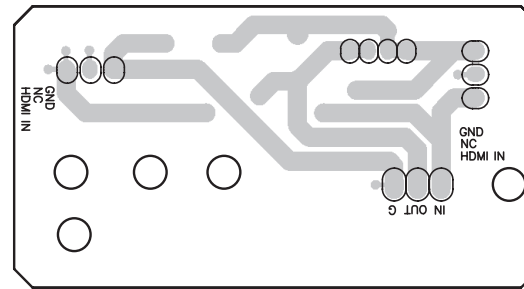

FOIL SIDE

NOTE FOR PARTS LIST

- Parts for which "nsp" is indicated on this table cannot be supplied.
- When ordering part, clearly indicate "1" and "l" (i) to avoid mis-supplying.
- Ordering part without stating its part number can not be supplied.
- Part indicated with the mark "★" is not illustrated in the exploded view.
- Not including General-purpose Carbon Film Resistor in the P.W.Board parts list. (Refer to the Schematic Diagram for those parts.)
- Not including General-purpose Carbon Chip Resistor in the P.W.Board parts list. (Refer to the Schematic Diagram for those parts.)

WARNING:

Parts marked with this symbol Δ have critical characteristics. Use ONLY replacement parts recommended by the manufacturer.

● Resistors

Ex.: RN 14K 2E 182 G FR

Type	Shape and performance	Power	Resistance	Allowable error	Others
RD : Carbon RC : Composition RS : Metal oxide film RW : Winding RN : Metal film RK : Metal mixture	2B : 1/8W 2E : 1/4W 2H : 1/2W 3A : 1W 3D : 2W 3F : 3W 3H : 5W	F : ±1% G : ±2% J : ±5% K : ±10% M : ±20%	P : Pulse-resistant type NL : Low noise type NB : Non-burning type FR : Fuse-resistor F : Lead wire forming		

* Resistance

1 8 2 ⇒ 1800 ohm = 1.8 kohm
Indicates number of zeros after effective number. 2-digit effective number.

• Units: ohm

1 R 2 ⇒ 1.2 ohm
1-digit effective number. 2-digit effective number, decimal point indicated by R.

• Units: ohm

● Capacitors

Ex.: CE 04W 1H 2R2 M BP

Type	Shape and performance	Dielectric strength	Capacity	Allowable error	Others
CE : Aluminum foil electrolytic CA : Aluminum solid electrolytic CS : Tantalum electrolytic CO : Film CK : Ceramic CC : Ceramic CP : Oil CM : Mica CF : Metallized CH : Metallized	0J : 6.3V 1A : 10V 1C : 16V 1E : 25V 1V : 35V 1H : 50V 2A : 100V 2B : 125V 2C : 160V 2D : 200V 2E : 250V 2H : 500V 2J : 630V	F : ±1% G : ±2% J : ±5% K : ±10% M : ±20% Z : +80% -20% P : +100% -0% C : ±0.25pF D : ±0.5pF = : Others	HS : High stability type BP : Non-polar type HR : Ripple-resistant type DL : For change and discharge HF : For assuring high frequency U : UL part C : CSA part W : UL-CSA type F : Lead wire forming		

* Capacity (electrolyte only)

2 2 2 ⇒ 2200μF
Indicates number of zeros after effective number. 2-digit effective number.

• Units: μF.

2 R 2 ⇒ 2.2μF
1-digit effective number. 2-digit effective number, decimal point indicated by R.

• Units: μF.

* Capacity (except electrolyte)

2 2 2 ⇒ 2200pF=0.0022μF
(More than 2) Indicates number of zeros after effective number. 2-digit effective number.

• Units: pF.

2 2 1 ⇒ 220pF
(0 or 1) Indicates number of zeros after effective number. 2-digit effective number.

• Units: pF.

• When the dielectric strength is indicated in AC, "AC" is included after the dielectric strength value.

部品表について

- 部品表に "nsp" と記載されている部品は供給できません。
- 部品を発注する際は特に数字の "1" と英字の "l" との区別をはっきり記入してください。
- 部品番号を表示していない部品は供給できません。
- Δ 印の部品は安全上重要な部品です。交換するときは、安全および性能維持のため必ず指定の部品をご使用ください。
- ★印のついている部品は分解図中には記載していません。
- 汎用カーボン抵抗器は記載していません。定数は回路図を参照願います。
- 汎用カーボンチップ抵抗器は記載していません。定数は回路図を参照願います。
- 部品表の抵抗器、コンデンサの品名記号の読み方は表を参照してください。

● 抵抗器

例) RN 14K 2E 182 G FR

RN	14K	2E	182	G	FR
種類	形状特性	電力	抵抗値	許容差	その他
RD : カーボン RC : 固定体 RS : 金属系皮膜 RW : 巻線 RN : 金属皮膜 RK : 金属混合体	2B : 1/8 W 2E : 1/4 W 2H : 1/2 W 3A : 1 W 3D : 2 W 3F : 3 W 3H : 5 W	F : ±1% G : ±2% J : ±5% K : ±10% M : ±20%	P : 耐バルス形 NL : 低雑音形 NB : 不燃形 FR : ヒューズ抵抗 F : リード線成形		

* 抵抗値

18 2 ⇒ 1800Ω=1.8kΩ
有効数字につづく0の数を表わす。2桁の有効数字を表わす。

1R 2 ⇒ 1.2Ω
1桁の有効数字を表わす。2桁の有効数字で小数点はRで表わす。

：単位はΩ

● コンデンサ

例) CE 04W 1H 2R2 M BP

CE	04W	1H	2R2	M	BP
種類	形状特性	耐圧	容量	許容差	その他
CE : アルミ箔電解 CA : アルミ固体電解 CS : タンタル電解 CQ : フィルム CK : セラミック CC : セラミック CP : オイル CM : マイカ CF : メタライズド CH : メタライズド	0J : 6.3 V 1A : 10 V 1C : 16 V 1E : 25 V 1V : 35 V 1H : 50 V 2A : 100 V 2B : 125 V 2C : 160 V 2D : 200 V 2E : 250 V 2H : 500 V 2J : 630 V	F : ±1% G : ±2% J : ±5% K : ±10% M : ±20% Z : +80% -20% P : +100% -0%	C : ±0.25pF D : ±0.5pF = : その他	HS : 高安定形 BP : 無極性形 DL : 耐リップル形 DR : 充放電対策用 HF : 高周波保証用 U : UL 部品 C : CSA 部品 W : UL-CSA 部品 F : リード線成形	

* 容量値

● 電解コンデンサの場合

22 2 ⇒ 2200μF
有効数字につづく0の数を表わす。2桁の有効数字を表わす。単位はμF

2R 2 ⇒ 2.2μF
1桁の有効数字を表わす。2桁の有効数字で小数点はRで表わす。単位はμF

● 電解コンデンサ以外の場合

22 2 ⇒ 2200pF=0.0022μF
有効数字につづく0の数を表わす。(0の数が2以上の場合) 2桁の有効数字を表わす。単位はpF

22 1 ⇒ 220pF
有効数字につづく0の数を表わす。(0の数が0または1の場合) 2桁の有効数字を表わす。単位はpF

● 耐圧を交流で表示する場合は、耐圧表示の次に「AC」を表示します。

PARTS LIST OF P.W.B. UNIT



AVR-1708 E3 MODEL

* 本表に "nsp" と記載されている部品は供給できません。

* Parts for which "nsp" is indicated on this table cannot be supplied.

* 本表に記載されている部品は、補修用部品のため製品に使用している部品とは一部、形状、寸法などが異なる場合があります。

* The parts listed below are for maintenance only, might differ from the parts used in the unit in appearances or dimensions.

MAIN P.W.B. UNIT ASS'Y

Ref. No.	Part No.	Part Name	Remarks	Q'ty	New
SEMICONDUCTORS GROUP					
IC110,111	00D 963 0218 807	IC BU4094BCF-E2	J040140940030S		
IC231	00D 960 0174 104	IC CXA1511M-T4	J030151100010S		
Q101	00D 960 0196 302	TR KTA1268BL	J5001268B0050S		
Q102-104	00D 960 0196 700	TR KTC3200BL	J5023200B0050S		
Q104C	00D 960 0196 506	TR KSC1845F	J5021845F0000S		
Q104FL	00D 960 0196 506	TR KSC1845F	J5021845F0000S		
Q104FR	00D 960 0196 506	TR KSC1845F	J5021845F0000S		
Q104SL	00D 960 0196 506	TR KSC1845F	J5021845F0000S		
Q104SR	00D 960 0196 506	TR KSC1845F	J5021845F0000S		
Q105	00D 960 0196 700	TR KTC3200BL	J5023200B0050S		
Q105C	00D 960 0196 603	TR KTC2874B	J502287400010S		
Q105FL	00D 960 0196 603	TR KTC2874B	J502287400010S		
Q105FR	00D 960 0196 603	TR KTC2874B	J502287400010S		
Q105SL	00D 960 0196 603	TR KTC2874B	J502287400010S		
Q105SR	00D 960 0196 603	TR KTC2874B	J502287400010S		
Q106	00D 960 0196 700	TR KTC3200BL	J5023200B0050S		
Q106C	00D 960 0196 205	TR KSA992F	J5000992F0050S		
Q106FL	00D 960 0196 205	TR KSA992F	J5000992F0050S		
Q106FR	00D 960 0196 205	TR KSA992F	J5000992F0050S		
Q106SL	00D 960 0196 205	TR KSA992F	J5000992F0050S		
Q106SR	00D 960 0196 205	TR KSA992F	J5000992F0050S		
Q107	00D 960 0196 700	TR KTC3200BL	J5023200B0050S		
Q107C	00D 960 0196 205	TR KSA992F	J5000992F0050S		
Q107FL	00D 960 0196 205	TR KSA992F	J5000992F0050S		
Q107FR	00D 960 0196 205	TR KSA992F	J5000992F0050S		
Q107SL	00D 960 0196 205	TR KSA992F	J5000992F0050S		
Q107SR	00D 960 0196 205	TR KSA992F	J5000992F0050S		
Q108	00D 960 0196 700	TR KTC3200BL	J5023200B0050S		
Q108C	00D 960 0196 506	TR KSC1845F	J5021845F0000S		
Q108FL	00D 960 0196 506	TR KSC1845F	J5021845F0000S		
Q108FR	00D 960 0196 506	TR KSC1845F	J5021845F0000S		
Q108SL	00D 960 0196 506	TR KSC1845F	J5021845F0000S		
Q108SR	00D 960 0196 506	TR KSC1845F	J5021845F0000S		
Q109,110	00D 960 0196 700	TR KTC3200BL	J5023200B0050S		
Q111	00D 960 0196 302	TR KTA1268BL	J5001268B0050S		
Q128	00D 960 0097 207	TR KRA102M	J6002202M0010S		
Q130	00D 960 0196 302	TR KTA1268BL	J5001268B0050S		
Q131,132	00D 963 0219 602	TR KRC106M	J6020106M0010S		
Q133-137	00D 960 0097 207	TR KRA102M	J6002202M0010S		
Q141SW	00D 963 0044 301	TR KTC2875B(MB)	J5222875B0010S		
Q142	00D 960 0196 700	TR KTC3200BL	J5023200B0050S		
Q142SW	00D 963 0044 301	TR KTC2875B(MB)	J5222875B0010S		
Q143,144	00D 960 0196 302	TR KTA1268BL	J5001268B0050S		
Q145	00D 960 0196 700	TR KTC3200BL	J5023200B0050S		
Q146,147	00D 960 0196 302	TR KTA1268BL	J5001268B0050S		
Q151	00D 960 0196 302	TR KTA1268BL	J5001268B0050S		
Q156	00D 960 0097 304	TR KRC102M	J6020102M0010S		

Ref. No.	Part No.	Part Name	Remarks	Q'ty	New
Q165	00D 960 0196 700	TR KTC3200BL	J5023200B0050S		
Q166-171	00D 960 0196 302	TR KTA1268BL	J5001268B0050S		
Q221L	00D 963 0044 301	TR KTC2875B(MB)	J5222875B0010S		
Q221R	00D 963 0044 301	TR KTC2875B(MB)	J5222875B0010S		
Q227L	00D 963 0044 301	TR KTC2875B(MB)	J5222875B0010S		
Q227R	00D 963 0044 301	TR KTC2875B(MB)	J5222875B0010S		
Q231	00D 960 0097 003	TR KRA104M	J6000104M0010S		
Q541	00D 963 0121 208	TR KRC107M	J6020107M0010S		
D101C	00D 963 0355 401	D,SWITCHING KDS4148U	K005041480030S		
D101FL	00D 963 0355 401	D,SWITCHING KDS4148U	K005041480030S		
D101FR	00D 963 0355 401	D,SWITCHING KDS4148U	K005041480030S		
D101SL	00D 963 0355 401	D,SWITCHING KDS4148U	K005041480030S		
D101SR	00D 963 0355 401	D,SWITCHING KDS4148U	K005041480030S		
D102C	00D 963 0355 401	D,SWITCHING KDS4148U	K005041480030S		
D102FL	00D 963 0355 401	D,SWITCHING KDS4148U	K005041480030S		
D102FR	00D 963 0355 401	D,SWITCHING KDS4148U	K005041480030S		
D102SL	00D 963 0355 401	D,SWITCHING KDS4148U	K005041480030S		
D102SR	00D 963 0355 401	D,SWITCHING KDS4148U	K005041480030S		
D105C	00D 963 0020 309	D,SWITCHING 1SS133T	K000013300520S		
D105FL	00D 963 0020 309	D,SWITCHING 1SS133T	K000013300520S		
D105FR	00D 963 0020 309	D,SWITCHING 1SS133T	K000013300520S		
D105SL	00D 963 0020 309	D,SWITCHING 1SS133T	K000013300520S		
D105SR	00D 963 0020 309	D,SWITCHING 1SS133T	K000013300520S		
D106,107	00D 963 0355 401	D,SWITCHING KDS4148U	K005041480030S		
D114,115	00D 960 0197 107	D,RECTIFIER BRIDGE KBPC604	K047604000020S		
D139	00D 963 0020 309	D,SWITCHING 1SS133T	K000013300520S		
D140,141	00D 963 0328 409	D,SWITCHING 1N4007	K000400700010S		
D142	00D 963 0355 401	D,SWITCHING KDS4148U	K005041480030S		
D143-152	00D 963 0020 309	D,SWITCHING 1SS133T	K000013300520S		
D153	00D 963 0355 401	D,SWITCHING KDS4148U	K005041480030S		
D154-157	00D 963 0020 309	D,SWITCHING 1SS133T	K000013300520S		
D231	00D 963 0355 401	D,SWITCHING KDS4148U	K005041480030S		
D541	00D 963 0355 401	D,SWITCHING KDS4148U	K005041480030S		
ZD101	00D 963 0058 601	D,ZENER MTZJ12B	K06012R044520S		
ZD101C	00D 963 0367 008	D,ZENER 0.2W 3.3V UDZ	K06603R34P400S		*
ZD101FL	00D 963 0367 008	D,ZENER 0.2W 3.3V UDZ	K06603R34P400S		*
ZD101FR	00D 963 0367 008	D,ZENER 0.2W 3.3V UDZ	K06603R34P400S		*
ZD101SL	00D 963 0367 008	D,ZENER 0.2W 3.3V UDZ	K06603R34P400S		*
ZD101SR	00D 963 0367 008	D,ZENER 0.2W 3.3V UDZ	K06603R34P400S		*
ZD102C	00D 963 0367 008	D,ZENER 0.2W 3.3V UDZ	K06603R04P400S		*
ZD102FL	00D 963 0367 008	D,ZENER 0.2W 3.3V UDZ	K06603R04P400S		*
ZD102FR	00D 963 0367 008	D,ZENER 0.2W 3.3V UDZ	K06603R04P400S		*
ZD102SL	00D 963 0367 008	D,ZENER 0.2W 3.3V UDZ	K06603R04P400S		*
ZD102SR	00D 963 0367 008	D,ZENER 0.2W 3.3V UDZ	K06603R04P400S		*
ZD105	00D 960 0095 500	D,ZENER MTZJ5.1B	K06005R144520S		
ZD231	00D 960 0095 704	D,ZENER MTZJ6.2B	K06006R244520S		
RESISTORS GROUP					
R101	00D 963 0337 801	R,METAL FILM 100-J,2W	C060010166520S		
R103	00D 963 9005 639	R,METAL FILM 100-J,1W	C060010165060S		
R104	00D 963 0215 907	R,METAL FILM 4.7-J,1W	C0604R7065050S		
R104C	00D 963 9006 285	R,FIXED 1WJ-5.6K	N113135656220S		
R104FL	00D 963 9006 285	R,FIXED 1WJ-5.6K	N113135656220S		

Ref. No.	Part No.	Part Name	Remarks	Q'ty	New
R104FR	00D 963 9006 285	R, FIXED 1WJ-5.6K	N113135656220S		
R104SL	00D 963 9006 285	R, FIXED 1WJ-5.6K	N113135656220S		
R104SR	00D 963 9006 285	R, FIXED 1WJ-5.6K	N113135656220S		
R105	00D 963 0232 906	R, METAL FILM 47K-F, 1/4W	C060047343530S		
R105C	00D 963 9006 285	R, FIXED 1WJ-5.6K	N113135656220S		
R105FL	00D 963 9006 285	R, FIXED 1WJ-5.6K	N113135656220S		
R105FR	00D 963 9006 285	R, FIXED 1WJ-5.6K	N113135656220S		
R105SL	00D 963 9006 285	R, FIXED 1WJ-5.6K	N113135656220S		
R105SR	00D 963 9006 285	R, FIXED 1WJ-5.6K	N113135656220S		
R106C	00D 963 0215 907	R, METAL FILM 4.7-J, 1W	C0604R7065050S		
R106FL	00D 963 0215 907	R, METAL FILM 4.7-J, 1W	C0604R7065050S		
R106FR	00D 963 0215 907	R, METAL FILM 4.7-J, 1W	C0604R7065050S		
R106SL	00D 963 0215 907	R, METAL FILM 4.7-J, 1W	C0604R7065050S		
R106SR	00D 963 0215 907	R, METAL FILM 4.7-J, 1W	C0604R7065050S		
R107C	00D 963 0215 907	R, METAL FILM 4.7-J, 1W	C0604R7065050S		
R107FL	00D 963 0215 907	R, METAL FILM 4.7-J, 1W	C0604R7065050S		
R107FR	00D 963 0215 907	R, METAL FILM 4.7-J, 1W	C0604R7065050S		
R107SL	00D 963 0215 907	R, METAL FILM 4.7-J, 1W	C0604R7065050S		
R107SR	00D 963 0215 907	R, METAL FILM 4.7-J, 1W	C0604R7065050S		
R108C	00D 963 0345 903	R, FIXED 2WJ-0.47	N113136647820S		
R108FL	00D 963 0345 903	R, FIXED 2WJ-0.47	N113136647820S		
R108FR	00D 963 0345 903	R, FIXED 2WJ-0.47	N113136647820S		
R108SL	00D 963 0345 903	R, FIXED 2WJ-0.47	N113136647820S		
R108SR	00D 963 0345 903	R, FIXED 2WJ-0.47	N113136647820S		
R109C	00D 963 0345 903	R, FIXED 2WJ-0.47	N113136647820S		
R109FL	00D 963 0345 903	R, FIXED 2WJ-0.47	N113136647820S		
R109FR	00D 963 0345 903	R, FIXED 2WJ-0.47	N113136647820S		
R109SL	00D 963 0345 903	R, FIXED 2WJ-0.47	N113136647820S		
R109SR	00D 963 0345 903	R, FIXED 2WJ-0.47	N113136647820S		
R110C	00D 963 0345 903	R, FIXED 2WJ-0.47	N113136647820S		
R110FL	00D 963 0345 903	R, FIXED 2WJ-0.47	N113136647820S		
R110FR	00D 963 0345 903	R, FIXED 2WJ-0.47	N113136647820S		
R110SL	00D 963 0345 903	R, FIXED 2WJ-0.47	N113136647820S		
R110SR	00D 963 0345 903	R, FIXED 2WJ-0.47	N113136647820S		
R111C	00D 963 0345 903	R, FIXED 2WJ-0.47	N113136647820S		
R111FL	00D 963 0345 903	R, FIXED 2WJ-0.47	N113136647820S		
R111FR	00D 963 0345 903	R, FIXED 2WJ-0.47	N113136647820S		
R111SL	00D 963 0345 903	R, FIXED 2WJ-0.47	N113136647820S		
R111SR	00D 963 0345 903	R, FIXED 2WJ-0.47	N113136647820S		
R117,118	00D 963 0144 502	R, CEMENT 0.1-J 5W	C141R10069000S		
R118C	00D 963 9006 256	R, FIXED 1WJ-10	N113135610020S		
R118FL	00D 963 9006 256	R, FIXED 1WJ-10	N113135610020S		
R118FR	00D 963 9006 256	R, FIXED 1WJ-10	N113135610020S		
R118SL	00D 963 9006 256	R, FIXED 1WJ-10	N113135610020S		
R118SR	00D 963 9006 256	R, FIXED 1WJ-10	N113135610020S		
R119C	00D 963 9006 256	R, FIXED 1WJ-10	N113135610020S		
R119FL	00D 963 9006 256	R, FIXED 1WJ-10	N113135610020S		
R119FR	00D 963 9006 256	R, FIXED 1WJ-10	N113135610020S		
R119SL	00D 963 9006 256	R, FIXED 1WJ-10	N113135610020S		
R119SR	00D 963 9006 256	R, FIXED 1WJ-10	N113135610020S		
R127C	00D 963 9005 642	R, METAL FILM 1.2K-J, 1W	C060012265050S		
R127FL	00D 963 9005 642	R, METAL FILM 1.2K-J, 1W	C060012265050S		
R127FR	00D 963 9005 642	R, METAL FILM 1.2K-J, 1W	C060012265050S		
R127SL	00D 963 9005 642	R, METAL FILM 1.2K-J, 1W	C060012265050S		
R127SR	00D 963 9005 642	R, METAL FILM 1.2K-J, 1W	C060012265050S		
R132C	00D 960 9010 719	R, METAL FILM 47-J, 1W	C060047065060S		

Ref. No.	Part No.	Part Name	Remarks	Q'ty	New
R132FL	00D 960 9010 719	R,METAL FILM 47-J,1W	C060047065060S		
R132FR	00D 960 9010 719	R,METAL FILM 47-J,1W	C060047065060S		
R132SL	00D 960 9010 719	R,METAL FILM 47-J,1W	C060047065060S		
R132SR	00D 960 9010 719	R,METAL FILM 47-J,1W	C060047065060S		
R147-149	00D 963 9005 642	R,METAL FILM 1.2K-J,1W	C060012265050S		
VR101C	00D 960 0221 109	VR,SEMI CARBON EVN-DJAA03B	C541102115000S		
VR101FL	00D 960 0221 109	VR,SEMI CARBON EVN-DJAA03B	C541102115000S		
VR101FR	00D 960 0221 109	VR,SEMI CARBON EVN-DJAA03B	C541102115000S		
VR101SL	00D 960 0221 109	VR,SEMI CARBON EVN-DJAA03B	C541102115000S		
VR101SR	00D 960 0221 109	VR,SEMI CARBON EVN-DJAA03B	C541102115000S		
CAPACITORS GROUP					
C101	00D 963 9005 804	C,ELECT 100UF-M/25V	D040101084060S		
C101C	00D 963 0234 506	C,ELECT 47UF-M/50V (Pb Free)	D040470087070S		
C101FL	00D 963 0234 506	C,ELECT 47UF-M/50V (Pb Free)	D040470087070S		
C101FR	00D 963 0234 506	C,ELECT 47UF-M/50V (Pb Free)	D040470087070S		
C101SL	00D 963 0234 506	C,ELECT 47UF-M/50V (Pb Free)	D040470087070S		
C101SR	00D 963 0234 506	C,ELECT 47UF-M/50V (Pb Free)	D040470087070S		
C102	00D 963 0224 503	C,ELECT 22UF-M/50V	D040220087060S		
C102C	00D 963 0234 205	C,ELECT 10UF-M/50V	D040100087070S		
C102FL	00D 960 9010 133	C,ELECT 220UF-M/35V	D040221085060S		
C102FR	00D 960 9010 133	C,ELECT 220UF-M/35V	D040221085060S		
C102SL	00D 963 0234 205	C,ELECT 10UF-M/50V	D040100087070S		
C102SR	00D 963 0234 205	C,ELECT 10UF-M/50V	D040100087070S		
C103	00D 963 9006 557	C,ELECT 220UF-M/6.3V	D040221081060S		
C103C	00D 963 9003 084	C,CERAMIC 100PF-K/500V	D00410106D050S		
C103FL	00D 963 9003 084	C,CERAMIC 100PF-K/500V	D00410106D050S		
C103FR	00D 963 9003 084	C,CERAMIC 100PF-K/500V	D00410106D050S		
C103SL	00D 963 9003 084	C,CERAMIC 100PF-K/500V	D00410106D050S		
C103SR	00D 963 9003 084	C,CERAMIC 100PF-K/500V	D00410106D050S		
C104	00D 963 9006 557	C,ELECT 220UF-M/6.3V	D040221081060S		
C104C	00D 963 9003 084	C,CERAMIC 100PF-K/500V	D00410106D050S		
C104FL	00D 963 9003 084	C,CERAMIC 100PF-K/500V	D00410106D050S		
C104FR	00D 963 9003 084	C,CERAMIC 100PF-K/500V	D00410106D050S		
C104SL	00D 963 9003 084	C,CERAMIC 100PF-K/500V	D00410106D050S		
C104SR	00D 963 9003 084	C,CERAMIC 100PF-K/500V	D00410106D050S		
C105	00D 963 9006 557	C,ELECT 220UF-M/6.3V	D040221081060S		
C105C	nsp	C,CERAMIC 0.022UF-Z/50V	D011223597160S		
C105FL	nsp	C,CERAMIC 0.022UF-Z/50V	D011223597160S		
C105FR	nsp	C,CERAMIC 0.022UF-Z/50V	D011223597160S		
C105SL	nsp	C,CERAMIC 0.022UF-Z/50V	D011223597160S		
C105SR	nsp	C,CERAMIC 0.022UF-Z/50V	D011223597160S		
C106	00D 963 0293 709	C,ELECT 100UF-M/10V	D040101082070S		
C107	nsp	C,CERAMIC 0.01UF-K/50V	D011103777160S		
C107C	00D 963 9003 097	C,FILM 0.1UF-K/250V	D02010407H080S		
C107FL	00D 963 9003 097	C,FILM 0.1UF-K/250V	D02010407H080S		
C107FR	00D 963 9003 097	C,FILM 0.1UF-K/250V	D02010407H080S		
C107SL	00D 963 9003 097	C,FILM 0.1UF-K/250V	D02010407H080S		
C107SR	00D 963 9003 097	C,FILM 0.1UF-K/250V	D02010407H080S		
C108	00D 963 0149 400	CAP.E.GENERIC 10000UF/63V(M)	N211210388110S		
C108C	00D 963 9006 544	C,ELECT 22UF-M/25V	D040220084050S		
C108FL	00D 963 9006 544	C,ELECT 22UF-M/25V	D040220084050S		
C108FR	00D 963 9006 544	C,ELECT 22UF-M/25V	D040220084050S		
C108SL	00D 963 9006 544	C,ELECT 22UF-M/25V	D040220084050S		

Ref. No.	Part No.	Part Name	Remarks	Q'ty	New
C108SR	00D 963 9006 544	C,ELECT 22UF-M/25V	D040220084050S		
C109	00D 963 0149 400	CAP.E.GENERIC 10000UF/63V(M)	N211210388110S		
C109C	00D 963 0234 205	C,ELECT 10UF-M/50V	D040100087070S		
C109FL	00D 963 0234 205	C,ELECT 10UF-M/50V	D040100087070S		
C109FR	00D 963 0234 205	C,ELECT 10UF-M/50V	D040100087070S		
C109SL	00D 963 0234 205	C,ELECT 10UF-M/50V	D040100087070S		
C109SR	00D 963 0234 205	C,ELECT 10UF-M/50V	D040100087070S		
C110	00D 963 9003 097	C,FILM 0.1UF-K/250V	D02010407H080S		
C110C	00D 963 0338 208	C,CERAMIC 470PF-K/500V	D00447127D050S		
C110FL	00D 963 0338 208	C,CERAMIC 470PF-K/500V	D00447127D050S		
C110FR	00D 963 0338 208	C,CERAMIC 470PF-K/500V	D00447127D050S		
C110SL	00D 963 0338 208	C,CERAMIC 470PF-K/500V	D00447127D050S		
C110SR	00D 963 0338 208	C,CERAMIC 470PF-K/500V	D00447127D050S		
C111	00D 963 9003 097	C,FILM 0.1UF-K/250V	D02010407H080S		
C111C	00D 963 0367 101	C,CERAMIC 220PF-J/500V	D00422106D05CS		*
C111FL	00D 963 0367 101	C,CERAMIC 220PF-J/500V	D00422106D05CS		*
C111FR	00D 963 0367 101	C,CERAMIC 220PF-J/500V	D00422106D05CS		*
C111SL	00D 963 0367 101	C,CERAMIC 220PF-J/500V	D00422106D05CS		*
C111SR	00D 963 0367 101	C,CERAMIC 220PF-J/500V	D00422106D05CS		*
C112	00D 963 9003 097	C,FILM 0.1UF-K/250V	D02010407H080S		
C112C	00D 963 9003 194	C,FILM 0.0022UF-J/100V	D02022206C060S		
C112FL	00D 963 9003 194	C,FILM 0.0022UF-J/100V	D02022206C060S		
C112FR	00D 963 9003 194	C,FILM 0.0022UF-J/100V	D02022206C060S		
C112SL	00D 963 9003 194	C,FILM 0.0022UF-J/100V	D02022206C060S		
C112SR	00D 963 9003 194	C,FILM 0.0022UF-J/100V	D02022206C060S		
C113C	00D 963 0293 709	C,ELECT 100UF-M/10V	D040101082070S		
C113FL	00D 960 9010 133	C,ELECT 220UF-M/35V	D040221085060S		
C113FR	00D 960 9010 133	C,ELECT 220UF-M/35V	D040221085060S		
C113SL	00D 963 0293 709	C,ELECT 100UF-M/10V	D040101082070S		
C113SR	00D 963 0293 709	C,ELECT 100UF-M/10V	D040101082070S		
C114	00D 963 9003 097	C,FILM 0.1UF-K/250V	D02010407H080S		
C114C	00D 963 0216 100	C,CERAMIC 33PF-J/500V	D00033006D050S		
C114FL	00D 963 0216 100	C,CERAMIC 33PF-J/500V	D00033006D050S		
C114FR	00D 963 0216 100	C,CERAMIC 33PF-J/500V	D00033006D050S		
C114SL	00D 963 0216 100	C,CERAMIC 33PF-J/500V	D00033006D050S		
C114SR	00D 963 0216 100	C,CERAMIC 33PF-J/500V	D00033006D050S		
C115	00D 963 9003 097	C,FILM 0.1UF-K/250V	D02010407H080S		
C115SW	00D 963 9006 544	C,ELECT 22UF-M/25V	D040220084050S		
C117-120	nsp	C,CERAMIC 0.1UF-K/50V	D011104577160S		
C141SW1	00D 963 0234 205	C,ELECT 10UF-M/50V	D040100087070S		
C142SW1	nsp	C,CERAMIC 100PF-J/50V	D010101167160S		
C155	00D 963 0244 606	C,ELECT 0.1UF-M/50V (Pb Free)	D040R10087080S		
C161	00D 963 0234 205	C,ELECT 10UF-M/50V	D040100087070S		
C162,163	nsp	C,CERAMIC 0.01UF-K/50V	D011103777160S		
C164-167	nsp	C,CERAMIC 100PF-J/50V	D010101167160S		
C168-172	00D 963 0244 606	C,ELECT 0.1UF-M/50V (Pb Free)	D040R10087080S		
C177	nsp	C,CERAMIC 0.01UF-K/50V	D011103777160S		
C178,179	00D 960 9010 010	C,ELECT 4.7UF-M/50V	D0404R7087250S		
C180,181	nsp	C,CERAMIC 0.01UF-K/50V	D011103777160S		
C182	00D 963 0324 005	C,ELECT 100UF-M/100V	D04010108C240S		
C183	00D 963 0293 602	C,ELECT 1UF-M/50V (Pb Free)	D040010087150S		
C190	00D 960 9010 010	C,ELECT 4.7UF-M/50V	D0404R7087250S		
C221L	nsp	C,CERAMIC 100PF-J/50V	D010101167160S		
C221R	nsp	C,CERAMIC 100PF-J/50V	D010101167160S		
C222L	00D 960 9010 010	C,ELECT 4.7UF-M/50V	D0404R7087250S		
C222R	00D 960 9010 010	C,ELECT 4.7UF-M/50V	D0404R7087250S		

Ref. No.	Part No.	Part Name	Remarks	Q'ty	New
C224L	00D 960 9010 010	C,ELECT 4.7UF-M/50V	D0404R7087250S		
C224R	00D 960 9010 010	C,ELECT 4.7UF-M/50V	D0404R7087250S		
C231	00D 963 0244 606	C,ELECT 0.1UF-M/50V (Pb Free)	D040R10087080S		
C232	nsp	C,CERAMIC 0.01UF-K/50V	D011103777160S		
C233	00D 963 0293 602	C,ELECT 1UF-M/50V (Pb Free)	D040010087150S		
C234	nsp	C,CERAMIC 100PF-J/50V	D010101167160S		
C235,236	00D 960 9008 653	C,FILM 0.012UF-J/100V	D02012306C060S		
C237	00D 963 9005 862	C,ELECT 47UF-M/16V	D040470083080S		
OTHERS PARTS GROUP					
BKT101	nsp	SHIELD PLATE GND	3070045526010S		*
CN101	nsp	CN,WIRE 14P	L000111140010S		*
CN103	nsp	CN,WIRE 7P	L000141070020S		*
CN201	nsp	CN,WIRE 4P	L000700100020S		*
CN511	nsp	CN,WIRE 9P	L000600090020S		
CN704	nsp	CN,WIRE 15P	L000600150030S		*
CP103	nsp	CN.WAFER 3P	L102526700300S		
CP104	nsp	CN.WAFER 3CKT	L108353280360S		
CP105,106	nsp	CN.WAFER 5P	L101100040510S		
CP107	nsp	CN.WAFER 3P	L102526700300S		
CP108	nsp	CN.WAFER 17P	L101100041710S		
CP541	nsp	CN.WAFER 3P	L101220030000S		
GND101	nsp	TERMINAL EARTH	3790040886000S		
JACK221	90M -YT 0046 40R	TER,RCA 2PIN	G601207AE020YS		*
JACK222	00D 963 0146 005	TER,RCA 1PIN	G600107A0000YS		
JACK231,232	00D 963 0244 703	JACK,D3.5 EARPHONE	G40130802000YS		
L101C	00D 963 0049 005	COIL INDUCTOR 0.5UH	D330R50000000S		
L101FL	00D 963 0049 005	COIL INDUCTOR 0.5UH	D330R50000000S		
L101FR	00D 963 0049 005	COIL INDUCTOR 0.5UH	D330R50000000S		
L101SL	00D 963 0049 005	COIL INDUCTOR 0.5UH	D330R50000000S		
L101SR	00D 963 0049 005	COIL INDUCTOR 0.5UH	D330R50000000S		
L231	nsp	BEAD,COIL 3580	7610010030000S		
RLY541	00D 963 0218 506	RELAY BC3-24 24V 2A	G680240202040S		
TP101-105	nsp	CN.WAFER 3P	L101530140310S		
JP108	00D 963 0223 009	R,THICK 0-J,1/16W	C20000006M160S		
JP347	nsp	C,CERAMIC 0.1UF-K/50V	D011104577160S		
JP352	00D 963 0223 009	R,THICK 0-J,1/16W	C20000006M160S		

FRONT P.W.B. UNIT ASS'Y

	Ref. No.	Part No.	Part Name	Remarks	Q'ty	New
SEMICONDUCTORS GROUP						
	IC301	00D 963 0074 504	IC BU2090F-E2	J044209000010S		
	IC302	00D 262 3758 009	LC87F6D64A-QFP-E	J127876160010S		*
▲	IC303	00D 960 0195 808	IC ICP-N15	J120001500030S		
	IC305	00D 963 0024 004	IC NJM2068M	J121206800020S		
	Q301-303	00D 963 0120 704	TR KRA102S	J520010200210S		
	Q304	00D 963 0121 606	TR KRC107S	J522107S00210S		
	Q305	00D 963 0102 803	TR 2SA933S	J5000933S0050S		
	Q306	00D 963 0120 801	TR KRC102S	J522010200210S		
	Q307-309	00D 963 0120 704	TR KRA102S	J520010200210S		
	Q310,311	00D 963 0120 801	TR KRC102S	J522010200210S		
	Q312	00D 960 0133 103	TR KSA916Y	J5000916Y0050S		
	Q542-546	00D 963 0121 208	TR KRC107M	J6020107M0010S		
	D301,302	00D 963 0020 309	D,SWITCHING 1SS133T	K000013300520S		
	D303	00D 963 0355 401	D,SWITCHING KDS4148U	K005041480030S		
	D304	00D 963 0020 309	D,SWITCHING 1SS133T	K000013300520S		
	D305-311	00D 963 0355 401	D,SWITCHING KDS4148U	K005041480030S		
	D312	00D 963 0328 409	D,SWITCHING 1N4007	K000400700010S		
	D315,316	00D 963 0355 401	D,SWITCHING KDS4148U	K005041480030S		
	D542	00D 963 0020 309	D,SWITCHING 1SS133T	K000013300520S		
	D543-545	00D 963 0355 401	D,SWITCHING KDS4148U	K005041480030S		
	D546	00D 963 0020 309	D,SWITCHING 1SS133T	K000013300520S		
	ZD302-308	00D 960 0095 500	D,ZENER MTZJ5.1B	K06005R144520S		
	ZD309	00D 960 0095 801	D,ZENER MTZJ6.8B	K06006R844520S		
	ZD310,311	00D 963 0046 202	D,ZENER MTZJ18B	K06018R044520S		
	ZD312,313	00D 960 0095 500	D,ZENER MTZJ5.1B	K06005R144520S		
	LED302-309	00D 960 0197 204	LED PI5-RD/HL50RDRF4T	K500052015010S		*
	LED310	00D 963 0366 108	LED BL-BEG204-L 5PI	K500052004010S		
	LED311	00D 963 0148 605	LED SML1216W 5PI	K500052600030S		
	FL301	00D 963 0257 305	DISPLAY,FLT HNA-16SM13T	K530161300020S		
RESISTORS GROUP						
	R372	00D 963 0215 907	R,METAL FILM 4.7-J,1W	C0604R7065050S		
	R378,379	00D 960 9009 270	R,METAL FILM 470-J,2W	C060047166520S		
	R501	00D 960 9003 700	R,METAL FILM 10-J,1/4W	C060010063050S		
	RP1-38	00D 963 0353 005	R,CHIP THICK 56K-J,1/16W	C20005636M160S		
	RG1-16	00D 963 0353 005	R,CHIP THICK 56K-J,1/16W	C20005636M160S		
CAPACITORS GROUP						
	C301,302	nsp	C,CERAMIC 100PF-J/50V	D010101167160S		
	C303	nsp	C,CERAMIC 0.022UF-K/25V	D011223777160S		
	C304	00D 963 9005 862	C,ELECT 47UF-M/16V	D040470083080S		
	C305	nsp	C,CERAMIC 100PF-J/50V	D010101167160S		
	C306	nsp	C,CERAMIC 0.047UF-Z/50V	D011473597160S		
	C307	00D 963 9005 862	C,ELECT 47UF-M/16V	D040470083080S		
	C308	nsp	C,CERAMIC 0.01UF-K/50V	D011103777160S		

Ref. No.	Part No.	Part Name	Remarks	Q'ty	New
C309,310	00D 963 0293 602	C,ELECT 1UF-M/50V (Pb Free)	D040010087150S		
C311	00D 963 0233 303	C,CERAMIC 0.01UF-M/16V	D005103773530S		
C312	00D 963 9005 862	C,ELECT 47UF-M/16V	D040470083080S		
C315	nsp	C,CERAMIC 150PF-J/50V	D010151167160S		
C316,317	nsp	C,CERAMIC 330PF-J/50V	D010331167160S		
C318	nsp	C,CERAMIC 100PF-J/50V	D010101167160S		
C319,320	nsp	C,CERAMIC 0.01UF-K/50V	D011103777160S		
C321,322	00D 963 0233 303	C,CERAMIC 0.01UF-M/16V	D005103773530S		
C323-325	00D 963 0293 602	C,ELECT 1UF-M/50V (Pb Free)	D040010087150S		
C326	00D 963 9005 862	C,ELECT 47UF-M/16V	D040470083080S		
C327,328	nsp	C,CERAMIC 0.1UF-K/50V	D011104577160S		
C329	nsp	C,FILM 0.1UF-J/100V	D02010406C060S		
C330	00D 963 0021 900	C,FILM 0.047UF-J/100V	D02047306C060S		
C331	00D 963 0234 205	C,ELECT 10UF-M/50V	D040100087070S		
C332	nsp	C,CERAMIC 150PF-J/50V	D010151167160S		
C333	00D 963 0293 602	C,ELECT 1UF-M/50V (Pb Free)	D040010087150S		
C334	00D 963 0021 900	C,FILM 0.047UF-J/100V	D02047306C060S		
C335	nsp	C,CERAMIC 0.1UF-K/50V	D011104577160S		
C336	nsp	C,CERAMIC 100PF-J/50V	D010101167160S		
C337	00D 963 0293 602	C,ELECT 1UF-M/50V (Pb Free)	D040010087150S		
C338	nsp	C,CERAMIC 0.01UF-K/50V	D011103777160S		
C339	nsp	C,CERAMIC 100PF-J/50V	D010101167160S		
C340	nsp	C,CERAMIC 1000PF-K/50V	D011102777160S		
C341,342	nsp	C,CERAMIC 100PF-J/50V	D010101167160S		
C343	00D 963 0020 202	C,CERAMIC 0.1UF-Z/50V	D005104597530S		
C344,345	00D 963 0233 206	C,CERAMIC 0.001UF-K/50V	D005102177530S		
C346-349	nsp	C,CERAMIC 0.01UF-K/50V	D011103777160S		
C350	00D 963 0021 900	C,FILM 0.047UF-J/100V	D02047306C060S		
C351	00D 963 0293 602	C,ELECT 1UF-M/50V (Pb Free)	D040010087150S		
C352	00D 963 0234 205	C,ELECT 10UF-M/50V	D040100087070S		
C353,354	00D 963 0293 602	C,ELECT 1UF-M/50V (Pb Free)	D040010087150S		
C355	nsp	C,ELECT 470UF-M/63V	D040471088010S		*
C356	00D 963 9003 097	C,FILM 0.1UF-K/250V	D02010407H080S		
C357,358	nsp	C,CERAMIC 0.047UF-Z/50V	D011473597160S		
C541	nsp	C,CERAMIC 2200PF-K/50V	D011222777160S		
C541FL	00D 963 0024 703	C,FILM 0.01UF-J/100V	D02010306C060S		
C542	nsp	C,CERAMIC 2200PF-K/50V	D011222777160S		
C542FR	00D 963 0024 703	C,FILM 0.01UF-J/100V	D02010306C060S		
C543	nsp	C,CERAMIC 2200PF-K/50V	D011222777160S		
C543FL	00D 963 0024 703	C,FILM 0.01UF-J/100V	D02010306C060S		
C544	nsp	C,CERAMIC 2200PF-K/50V	D011222777160S		
C544FR	00D 963 0024 703	C,FILM 0.01UF-J/100V	D02010306C060S		
C545	nsp	C,CERAMIC 2200PF-K/50V	D011222777160S		
C545C	00D 963 0024 703	C,FILM 0.01UF-J/100V	D02010306C060S		
C546	nsp	C,CERAMIC 2200PF-K/50V	D011222777160S		
C546SL	00D 963 0024 703	C,FILM 0.01UF-J/100V	D02010306C060S		
C547	nsp	C,CERAMIC 2200PF-K/50V	D011222777160S		
C547SR	00D 963 0024 703	C,FILM 0.01UF-J/100V	D02010306C060S		
C548	nsp	C,CERAMIC 2200PF-K/50V	D011222777160S		
C548SBL	00D 963 0024 703	C,FILM 0.01UF-J/100V	D02010306C060S		
C549	nsp	C,CERAMIC 2200PF-K/50V	D011222777160S		
C549SBR	00D 963 0024 703	C,FILM 0.01UF-J/100V	D02010306C060S		
OTHERS PARTS GROUP					
BD301-307	nsp	COIL,BEAD MB-160808	D340160800060S		

Ref. No.	Part No.	Part Name	Remarks	Q'ty	New
CN102	nsp	CN,WIRE 4P	L000271040040S		
CN301	nsp	CN,WIRE 2P	L000401020050S		*
CN302A	nsp	CN,WIRE 5P	L000450050010S		*
CN303A	nsp	CN,WIRE 8P	L000450080010S		*
CN304	nsp	CN,WIRE 3P	L000500030050S		*
CN305	nsp	CN,WIRE 10P	L000700100030S		*
CN541		CN,WIRE 3P	L000251030080S		
CP101	nsp	CN.WAFER 10P	L102526701000S		*
CP103	nsp	CN.WAFER 07P	L101220070010S		
CP105	nsp	CN.WAFER 4P ANGLE	L102526800400S		*
CP301B	00D 963 0368 506	CN.FPC 35P	L131103500010S		*
CP302	nsp	CN.WAFER 3P ANGLE	L102526803010S		
CP304	nsp	CN.WAFER 3P	L101220030000S		
CP305	nsp	CN.WAFER 10P	L101220100010S		
CP306	nsp	CN.WAFER 03P	L101220030010S		
G301	nsp	RING,TER WIRE 120MM/1P	8410121010060S		
G302	nsp	RING,TER WIRE 120MM/1P	8410121010110S		
G304	nsp	RING,TER WIRE 80MM/2P	8410800020040S		
JACK301	00D 963 0367 802	JACK,D3.5 EARPHONE	G401PJ354H40YS		*
JACK304	00D 963 0146 403	TER,RCA 3PIN	G606308HG110YS		
JACK501,502	00D 963 0146 607	TER,BOARD SCREW 8P	G614801A0200YS		
JACK503	00D 963 0158 608	TER,BOARD SCREW 2P	G611201A0200YS		
JK302	00D 963 0294 708	JACK,D6.5 PHONE	G402PJ612AG0YS		
L302	nsp	COIL INDUCTOR 10UH	D330100700520S		
L303	nsp	COIL INDUCTOR 100UH	D330101001020S		
RLY541	00D 963 0366 201	RELAY G5PA-28-MC 24V 5A	G680240502030S		*
RLY543-546	00D 963 0366 201	RELAY G5PA-28-MC 24V 5A	G680240502030S		*
RMC301	00D 963 0217 808	MODULE,REMOCON NJL34H380A	E940343800010S		
⚠ SW301	00D 963 0145 802	SW,PUSH SDDL-005-S(C-UL)	G000122006060S		
SW301A	00D 963 0095 305	SW,TACT SKHV10910D01	G180040500010S		
SW301C	00D 963 0095 305	SW,TACT SKHV10910D01	G180040500010S		
SW302A	00D 963 0095 305	SW,TACT SKHV10910D01	G180040500010S		
SW302B	00D 963 0095 305	SW,TACT SKHV10910D01	G180040500010S		
SW302C	00D 963 0095 305	SW,TACT SKHV10910D01	G180040500010S		
SW303A	00D 963 0095 305	SW,TACT SKHV10910D01	G180040500010S		
SW303B	00D 963 0095 305	SW,TACT SKHV10910D01	G180040500010S		
SW303C	00D 963 0095 305	SW,TACT SKHV10910D01	G180040500010S		
SW304A	00D 963 0095 305	SW,TACT SKHV10910D01	G180040500010S		
SW304B	00D 963 0095 305	SW,TACT SKHV10910D01	G180040500010S		
SW304C	00D 963 0095 305	SW,TACT SKHV10910D01	G180040500010S		
SW305A	00D 963 0095 305	SW,TACT SKHV10910D01	G180040500010S		
SW305B	00D 963 0095 305	SW,TACT SKHV10910D01	G180040500010S		
SW305C	00D 963 0095 305	SW,TACT SKHV10910D01	G180040500010S		
SW306A	00D 963 0095 305	SW,TACT SKHV10910D01	G180040500010S		
SW306B	00D 963 0095 305	SW,TACT SKHV10910D01	G180040500010S		
SW306C	00D 963 0095 305	SW,TACT SKHV10910D01	G180040500010S		
SW307A	00D 963 0095 305	SW,TACT SKHV10910D01	G180040500010S		

Ref. No.	Part No.	Part Name	Remarks	Q'ty	New
SW307B	00D 963 0095 305	SW,TACT SKHV10910D01	G180040500010S		
SW307C	00D 963 0095 305	SW,TACT SKHV10910D01	G180040500010S		
SW308A	00D 963 0095 305	SW,TACT SKHV10910D01	G180040500010S		
SW308B	00D 963 0095 305	SW,TACT SKHV10910D01	G180040500010S		
SW308C	00D 963 0095 305	SW,TACT SKHV10910D01	G180040500010S		
SW309A	00D 963 0095 305	SW,TACT SKHV10910D01	G180040500010S		
SW310	00D 963 0095 305	SW,TACT SKHV10910D01	G180040500010S		
VEC203	00D 963 0300 401	SW,ENCODER EC11B20C2	G121112020000S		
VEC301	00D 963 0095 208	SW,ENCODER EC16B24SA	G121162400040S		
VEC303	00D 963 0095 208	SW,ENCODER EC16B24SA	G121162400040S		
	nsp	HOLDER FLT	4320200026000S		

INPUT P.W.B. UNIT ASS'Y

Ref. No.	Part No.	Part Name	Remarks	Q'ty	New
SEMICONDUCTORS GROUP					
IC700	00D 963 0366 304	IC R2A15215FP		J084152150010S	*
IC702	00D 963 0024 004	IC NJM2068M		J121206800020S	
IC705-718	00D9630024004	IC NJM2068M		J121206800020S	
Q700,701	00D 960 0196 807	TR 2SK117Y		J5441170Y0050S	
Q702	00D 963 0120 704	TR KRA102S		J520010200210S	
Q703	00D 960 0285 006	TR KRC104S		J522104S00210S	
D700,701	00D 963 0355 401	D,SWITCHING KDS4148U		K005041480030S	
ZD700,701	00D 960 0222 603	D,ZENER MTZJ7.5A		K06007R544530S	
RESISTORS GROUP					
R706-709	00D 963 9005 639	R,METAL FILM 100-J,1W		C060010165060S	*
R791VC	nsp	R,METAL FILM 120-J,1W		C060012165060S	*
R791VE	nsp	R,METAL FILM 120-J,1W		C060012165060S	*
CAPACITORS GROUP					
C700	00D 963 0234 205	C,ELECT 10UF-M/50V		D040100087070S	
C702SW	00D 960 9010 010	C,ELECT 4.7UF-M/50V		D0404R7087250S	
C703C	nsp	C,CERAMIC 0.047UF-Z/50V		D011473597160S	
C703SW	nsp	C,CERAMIC 0.047UF-Z/50V		D011473597160S	
C704,705	00D 963 9005 875	C,ELECT 47UF-M/25V		D040470084070S	
C706FL	00D 963 9005 875	C,ELECT 47UF-M/25V		D040470084070S	
C706FR	00D 963 9005 875	C,ELECT 47UF-M/25V		D040470084070S	
C707FL	00D 963 0234 205	C,ELECT 10UF-M/50V		D040100087070S	
C707FR	00D 963 0234 205	C,ELECT 10UF-M/50V		D040100087070S	
C707SW	00D 963 0234 205	C,ELECT 10UF-M/50V		D040100087070S	
C708FL	nsp	C,CERAMIC 33PF-J/50V		D010330167160S	
C708FR	nsp	C,CERAMIC 33PF-J/50V		D010330167160S	
C708SW	nsp	C,CERAMIC 47PF-J/50V		D010470167160S	
C709FL	nsp	C,CERAMIC 0.047UF-Z/50V		D011473597160S	
C709FR	nsp	C,CERAMIC 0.047UF-Z/50V		D011473597160S	
C709SW	nsp	C,CERAMIC 0.047UF-Z/50V		D011473597160S	
C710	00D 963 0223 009	R,THICK 0-J,1/16W		C20000006M160S	
C710FL	nsp	C,CERAMIC 100PF-J/50V		D010101167160S	
C710FR	nsp	C,CERAMIC 100PF-J/50V		D010101167160S	
C710SW	nsp	C,CERAMIC 100PF-J/50V		D010101167160S	
C711	00D 963 0223 009	R,THICK 0-J,1/16W		C20000006M160S	
C711FL	nsp	C,CERAMIC 0.047UF-Z/50V		D011473597160S	
C711FR	nsp	C,CERAMIC 0.047UF-Z/50V		D011473597160S	
C711SW	nsp	C,CERAMIC 0.047UF-Z/50V		D011473597160S	
C712	00D 963 0293 602	C,ELECT 1UF-M/50V (Pb Free)		D040010087150S	
C713-715	00D 963 0223 009	R,THICK 0-J,1/16W		C20000006M160S	
C716-727	00D 960 9009 814	C,CERAMIC 330PF-J/50V		D010331167160S	
C728-731	nsp	C,CERAMIC 20PF-J/50V		D010200167160S	
C732-739	00D 960 9009 814	C,CERAMIC 330PF-J/50V		D010331167160S	
C740-751	00D 963 0234 205	C,ELECT 10UF-M/50V		D040100087070S	
C751A	00D 963 0234 205	C,ELECT 10UF-M/50V		D040100087070S	
C751B	00D 963 0234 205	C,ELECT 10UF-M/50V		D040100087070S	
C751C	00D 963 0234 205	C,ELECT 10UF-M/50V		D040100087070S	
C751D	00D 963 0234 205	C,ELECT 10UF-M/50V		D040100087070S	

Ref. No.	Part No.	Part Name	Remarks	Q'ty	New
C751E	00D 963 0234 205	C,ELECT 10UF-M/50V	D040100087070S		
C751F	00D 963 0234 205	C,ELECT 10UF-M/50V	D040100087070S		
C751G	00D 963 0234 205	C,ELECT 10UF-M/50V	D040100087070S		
C751H	00D 963 0234 205	C,ELECT 10UF-M/50V	D040100087070S		
C751J	00D 963 0234 205	C,ELECT 10UF-M/50V	D040100087070S		
C751K	00D 963 0234 205	C,ELECT 10UF-M/50V	D040100087070S		
C751L	00D 963 0234 205	C,ELECT 10UF-M/50V	D040100087070S		
C751M	00D 963 0234 205	C,ELECT 10UF-M/50V	D040100087070S		
C751N	00D 963 0234 205	C,ELECT 10UF-M/50V	D040100087070S		
C751P	00D 963 0234 205	C,ELECT 10UF-M/50V	D040100087070S		
C751Q	00D 963 0234 205	C,ELECT 10UF-M/50V	D040100087070S		
C751R	00D 963 0234 205	C,ELECT 10UF-M/50V	D040100087070S		
C751S	00D 963 0234 205	C,ELECT 10UF-M/50V	D040100087070S		
C751T	00D 963 0234 205	C,ELECT 10UF-M/50V	D040100087070S		
C751U	00D 963 0234 205	C,ELECT 10UF-M/50V	D040100087070S		
C751V	00D 963 0234 205	C,ELECT 10UF-M/50V	D040100087070S		
C752	00D 963 0234 205	C,ELECT 10UF-M/50V	D040100087070S		
C752A	nsp	C,CERAMIC 0.047UF-Z/50V	D011473597160S		
C752B	nsp	C,CERAMIC 0.047UF-Z/50V	D011473597160S		
C752C	nsp	C,CERAMIC 0.047UF-Z/50V	D011473597160S		
C752D	nsp	C,CERAMIC 0.047UF-Z/50V	D011473597160S		
C752E	nsp	C,CERAMIC 0.047UF-Z/50V	D011473597160S		
C752F	nsp	C,CERAMIC 0.047UF-Z/50V	D011473597160S		
C752G	nsp	C,CERAMIC 0.047UF-Z/50V	D011473597160S		
C752H	nsp	C,CERAMIC 0.047UF-Z/50V	D011473597160S		
C752J	nsp	C,CERAMIC 0.047UF-Z/50V	D011473597160S		
C752K	nsp	C,CERAMIC 0.047UF-Z/50V	D011473597160S		
C752L	nsp	C,CERAMIC 0.047UF-Z/50V	D011473597160S		
C752M	nsp	C,CERAMIC 0.047UF-Z/50V	D011473597160S		
C752N	nsp	C,CERAMIC 0.047UF-Z/50V	D011473597160S		
C752P	nsp	C,CERAMIC 0.047UF-Z/50V	D011473597160S		
C752Q	nsp	C,CERAMIC 0.047UF-Z/50V	D011473597160S		
C752R	nsp	C,CERAMIC 0.047UF-Z/50V	D011473597160S		
C752S	nsp	C,CERAMIC 0.047UF-Z/50V	D011473597160S		
C752T	nsp	C,CERAMIC 0.047UF-Z/50V	D011473597160S		
C752U	nsp	C,CERAMIC 0.047UF-Z/50V	D011473597160S		
C752V	nsp	C,CERAMIC 0.047UF-Z/50V	D011473597160S		
C752W	nsp	C,CERAMIC 0.1UF-Z/50V	D011104597160S		
C752X	nsp	C,CERAMIC 0.1UF-Z/50V	D011104597160S		
C753-771	00D 963 0234 205	C,ELECT 10UF-M/50V	D040100087070S		
C772,773	00D 963 0293 806	C,ELECT 100UF-M/10V (Pb Free)	D040101082090S		
C774	nsp	C,FILM 0.15UF-K/63V	D020154078060S		*
C775	00D 963 0021 900	C,FILM 0.047UF-J/100V	D02047306C060S		
C776	00D 960 9008 640	C,FILM 0.022UF-J/100V	D02022306C060S		
C777	00D 963 0234 205	C,ELECT 10UF-M/50V	D040100087070S		
C778,779	nsp	C,CERAMIC 100PF-J/50V	D010101167160S		
C780	00D 963 0234 205	C,ELECT 10UF-M/50V	D040100087070S		
C781	00D 960 9008 640	C,FILM 0.022UF-J/100V	D02022306C060S		
C782	00D 963 0021 900	C,FILM 0.047UF-J/100V	D02047306C060S		
C783	nsp	C,FILM 0.15UF-K/63V	D020154078060S		*
C784-790	00D 963 0293 806	C,ELECT 100UF-M/10V (Pb Free)	D040101082090S		
C791-793	00D 963 0234 205	C,ELECT 10UF-M/50V	D040100087070S		
C794	00D 963 0293 806	C,ELECT 100UF-M/10V (Pb Free)	D040101082090S		
C795-799	00D 963 0234 205	C,ELECT 10UF-M/50V	D040100087070S		
C800,801	00D 960 9010 832	C,ELECT 10UF-M/16V	D040100083050S		

Ref. No.	Part No.	Part Name	Remarks	Q'ty	New
OTHERS PARTS GROUP					
CLAMP501	nsp	CLAMP WIRE(SOLDER)		4330000120000S	
CN514	nsp	CN,WIRE 13P		L000181130010S	*
CN702	nsp	CN.HOUSING 15P		L120912150010S	*
CN703	nsp	CN.WAFER 8P		L101100030810S	
CN704	nsp	CN.WAFER 19P		L101100031910S	
CN706	nsp	CN,WIRE 8P		L000121080010S	*
CP704	nsp	CN.WAFER 15P		L101220150000S	
CP705	nsp	CN.WAFER 3P		L101220030000S	
JACK701	00D 963 0132 103	TER,RCA 4PIN		G602405B0400YS	
JACK702	00D 963 0387 505	TER,RCA 4PIN		G602405B5500YS	
JACK703	00D 963 0132 103	TER,RCA 4PIN		G602405B0400YS	
JACK704,705	00D 963 0132 307	TER,RCA 6PIN		G603603B05000S	

POWER P.W.B. UNIT ASS'Y

	Ref. No.	Part No.	Part Name	Remarks	Q'ty	New
SEMICONDUCTORS GROUP						
△	IC501	00D 963 0057 806	IC KIA78R05PI	J126780500370S		
	IC502	00D 960 0195 808	IC ICP-N15	J120001500030S		
	IC511	00D 963 0147 606	IC KIA78R09API	J126780900120S		
	IC512	00D 960 0159 501	IC KIA7805API	J126780500110S		
	IC513	00D 963 0327 507	IC KIA7905PI	J126790500070S		
	IC515	00D 960 0174 900	IC KIA7815API	J126781500000S		
	IC516	00D 963 0021 502	IC KIA7915PI	J126791500030S		
	Q501	00D 960 0196 409	TR 2SC1740SR	J5021740S0010S		
	Q502	00D 963 0121 208	TR KRC107M	J6020107M0010S		
	Q503	00D 960 0196 409	TR 2SC1740SR	J5021740S0010S		
	D501-503	00D 276 0401 905	D,SWITCHING 1SS133T	K000013300520S		
	D504-507	00D 963 0328 409	D,SWITCHING 1N4007	K000400700010S		
	D508,509	00D 276 0401 905	D,SWITCHING 1SS133T	K000013300520S		
	D511,512	00D 276 0401 905	D,SWITCHING 1SS133T	K000013300520S		
	D513-520	00D 963 0328 409	D,SWITCHING 1N4007	K000400700010S		
	D521,522	00D 276 0401 905	D,SWITCHING 1SS133T	K000013300520S		
	D523-526	00D 963 0328 409	D,SWITCHING 1N4007	K000400700010S		
	ZD501	00D 960 0095 500	D,ZENER MTZJ5.1B	K06005R144520S		
	ZD502	00D 963 0219 903	D,ZENER MTZJ16B	K06016R044520S		
RESISTORS GROUP						
	R506	00D 963 0244 305	R,METAL FILM 2.2M 0.5W	C060022564520S		
	R507	00D 241 2376 964	R,METAL FILM 47-J,1/4W	C060047063050S		
	R508,509	00D 963 0216 003	R,METAL FILM 0.22-J,1W	C060R22065050S		
	R516-519	00D 963 0216 003	R,METAL FILM 0.22-J,1W	C060R22065050S		
CAPACITORS GROUP						
	C501	00D 963 0234 205	C,ELECT 10UF-M/50V	D040100087070S		
	C502	00D 963 0217 002	C,ELECT 3300UF-M/16V	D040332083010S		
	C503	00D 963 0293 602	C,ELECT 1UF-M/50V (Pb Free)	D040010087150S		
	C504	00D 963 0323 802	C,CERAMIC AC(SAFETY) 0.0047UF 250VAC	D00847208H010S		
	C506	00D 963 0293 602	C,ELECT 1UF-M/50V (Pb Free)	D040010087150S		
	C514-516	00D 963 0293 602	C,ELECT 1UF-M/50V (Pb Free)	D040010087150S		
	C517	00D 963 0234 205	C,ELECT 10UF-M/50V	D040100087070S		
	C518	00D 963 0217 002	C,ELECT 3300UF-M/16V	D040332083010S		
	C519	00D 963 0324 704	C,ELECT 4700UF-M/16V	D040472083200S		
	C520	00D 963 0021 104	C,ELECT 6800UF-M/16V	D040682083000S		
	C521-523	00D 963 0021 900	C,FILM 0.047UF-J/100V	D02047306C060S		
	C526,527	00D 960 0186 202	C,ELECT 220UF-M/35V	D040221085050S		
	C528	00D 963 0324 908	C,ELECT 4700UF-M/35V	D040472085020S		
	C529	00D 963 0224 707	C,ELECT 2200UF-M/35V	D040222085020S		
	C530-532	00D 963 0021 900	C,FILM 0.047UF-J/100V	D02047306C060S		
OTHERS PARTS GROUP						
	BKT501	nsp	SHIELD PLATE GND	3070045526010S		
	CLAMP102,103	nsp	CLAMP WIRE(SOLDER)	4330000120000S		

Ref. No.	Part No.	Part Name	Remarks	Q'ty	New
CN505	nsp	CN.WAFER 7P	L101100030710S		
CN506	nsp	CN.WAFER 12P	L101100031210S		
CP501	nsp	CN.WAFER 2CKT,YEL	L108353280290S		
CP503	nsp	CN.WAFER 2CKT,RED	L108353280280S		
CP504	nsp	CN.WAFER ST2P	L108202000220S		
CP505	nsp	CN.WAFER 7P	L101100040710S		
CP506	nsp	CN.WAFER 12P	L101100041210S		
CP511	nsp	CN.WAFER 9P-S2T2-EF	L101220090000S		
CP512	nsp	CN.WAFER 4P ANGLE	L102526800400S		*
CP513	nsp	CN.WAFER 3P ANGLE	L102526803010S		
CP514		CN.WAFER 13P	L101220130000S		
⚠ F501	00D 963 0236 106	FUSE T8A /250V	N751228001110S		
F501A	nsp	HOLDER,FUSE CLIP	G645000050010S		
F501B	nsp	HOLDER,FUSE CLIP	G645000050010S		
⚠ F503	00D 963 0236 106	FUSE T8A /250V	N751228001110S		
F503A	nsp	HOLDER,FUSE CLIP	G645000050010S		
F503B	nsp	HOLDER,FUSE CLIP	G645000050010S		
GND501	nsp	TERMINAL EARTH	3790040886000S		
RLY501	00D 963 0218 205	RELAY HL3-1A-9SH DC9V 1A	G680090102020S		
⚠ SUB501	00D 963 0382 704	SUB TRANS	8200280150400S		
	nsp	HEAT SINK	2120043538050S		
	nsp	SCREW,TAP TITE +2S 3*8 B-TYPE ZNW/BH	B020030081B10S		
	00D 963 0328 409	D,SWITCHING 1N4007	K000400700010S		
⚠	00D 203 3976 002	SOCKET,POWER RECEP	G435204004010S		

2CH-AMP P.W.B. UNIT ASS'Y

Ref. No.	Part No.	Part Name	Remarks	Q'ty	New
SEMICONDUCTORS GROUP					
IC401D	00D 960 0159 501	IC KIA7805API	J126780500110S		
IC401H	00D 963 0388 805	CN,WIRE 110MM/3P	L000111030040S		
IC402D	00D 963 0226 608	IC KIA78R33PI	J12678R330010S		
IC402X	00D 963 0366 603	IC KIA1117PI50	J126111750050S		*
IC403	00D 963 0334 503	IC PQ20RX11	J126201100010S		
IC403D	00D 963 0366 706	IC KIA1117PI00	J126111700050S		*
Q401SBL	00D 963 0044 204	TR 2SD2390-Y	J5032390Y0000S		
Q401SBR	00D 963 0044 204	TR 2SD2390-Y	J5032390Y0000S		
Q401X	00D 963 0120 801	TR KRC102S	J522010200210S		
Q402D	00D 960 0097 304	TR KRC102M	J6020102M0010S		
Q402SBL	00D 963 0044 107	TR 2SB1560-Y	J5011560Y0000S		
Q402SBR	00D 963 0044 107	TR 2SB1560-Y	J5011560Y0000S		
Q402X	00D 963 0120 801	TR KRC102S	J522010200210S		
Q403SBL	00D 963 0280 107	TR 2SC3964	J502396400000S		
Q403SBR	00D 963 0280 107	TR 2SC3964	J502396400000S		
Q404SBL	00D 960 0196 506	TR KSC1845F	J5021845F0000S		
Q404SBR	00D 960 0196 506	TR KSC1845F	J5021845F0000S		
Q405SBL	00D 273 0459 903	TR KTC2874B	J502287400010S		
Q405SBR	00D 273 0459 903	TR KTC2874B	J502287400010S		
Q406SBL	00D 960 0196 205	TR KSA992F	J5000992F0050S		
Q406SBR	00D 960 0196 205	TR KSA992F	J5000992F0050S		
Q407SBL	00D 960 0196 205	TR KSA992F	J5000992F0050S		
Q407SBR	00D 960 0196 205	TR KSA992F	J5000992F0050S		
Q408SBL	00D 960 0196 506	TR KSC1845F	J5021845F0000S		
Q408SBR	00D 960 0196 506	TR KSC1845F	J5021845F0000S		
Q409D	00D 960 0097 304	TR KRC102M	J6020102M0010S		
D401H	00D 963 0328 409	D,SWITCHING 1N4007	K000400700010S		
D401SBL	00D 963 0341 004	D,SWITCHING KDS4148U	K005041480030S		
D401SBR	00D 963 0341 004	D,SWITCHING KDS4148U	K005041480030S		
D401X	00D 963 0328 409	D,SWITCHING 1N4007	K000400700010S		
D402	00D 276 0401 905	D,SWITCHING 1SS133T	K000013300520S		
D402H	00D 963 0328 409	D,SWITCHING 1N4007	K000400700010S		
D402SBL	00D 963 0341 004	D,SWITCHING KDS4148U	K005041480030S		
D402SBR	00D 963 0341 004	D,SWITCHING KDS4148U	K005041480030S		
D402X	00D 963 0328 409	D,SWITCHING 1N4007	K000400700010S		
D403	00D 276 0401 905	D,SWITCHING 1SS133T	K000013300520S		
ZD401D	00D 960 0095 607	D,ZENER MTZJ5.6B	K06005R644520S		
ZD401SBL	00D 963 0367 008	D,ZENER 0.2W 3.3V UDZ	K06603R34P400S		
ZD401SBR	00D 963 0367 008	D,ZENER 0.2W 3.3V UDZ	K06603R34P400S		
ZD402SBL	00D 963 0367 008	D,ZENER 0.2W 3.3V UDZ	K06603R04P400S		
ZD402SBR	00D 963 0367 008	D,ZENER 0.2W 3.3V UDZ	K06603R04P400S		
RESISTORS GROUP					
R401D	00D 963 9006 269	R,FIXED 1WJ-0.22	N113135622820S		
R401H	00D 963 9006 269	R,FIXED 1WJ-0.22	N113135622820S		
R401X	00D 963 9006 269	R,FIXED 1WJ-0.22	N113135622820S		
R402D	00D 963 9006 269	R,FIXED 1WJ-0.22	N113135622820S		
R402H	00D 963 9006 269	R,FIXED 1WJ-0.22	N113135622820S		
R402X	00D 963 9006 269	R,FIXED 1WJ-0.22	N113135622820S		
R410SBL	00D 963 9005 642	R,METAL FILM 1.2K-J,1W	C060012265050S		

Ref. No.	Part No.	Part Name	Remarks	Q'ty	New
R410SBR	00D 963 9005 642	R,METAL FILM 1.2K-J,1W	C060012265050S		
R411SBL	00D 960 9010 719	R,METAL FILM 47-J,1W	C060047065060S		
R411SBR	00D 960 9010 719	R,METAL FILM 47-J,1W	C060047065060S		
R414SBL	00D 963 9006 285	R,FIXED 1WJ-5.6K	N113135656220S		
R414SBR	00D 963 9006 285	R,FIXED 1WJ-5.6K	N113135656220S		
R415SBL	00D 963 9006 285	R,FIXED 1WJ-5.6K	N113135656220S		
R415SBR	00D 963 9006 285	R,FIXED 1WJ-5.6K	N113135656220S		
R419SBL	00D 963 0215 907	R,METAL FILM 4.7-J,1W	C0604R7065050S		
R419SBR	00D 963 0215 907	R,METAL FILM 4.7-J,1W	C0604R7065050S		
R420SBL	00D 963 0215 907	R,METAL FILM 4.7-J,1W	C0604R7065050S		
R420SBR	00D 963 0215 907	R,METAL FILM 4.7-J,1W	C0604R7065050S		
R421SBL	00D 963 0345 903	R,FIXED 2WJ-0.47	N113136647820S		
R421SBR	00D 963 0345 903	R,FIXED 2WJ-0.47	N113136647820S		
R422SBL	00D 963 0345 903	R,FIXED 2WJ-0.47	N113136647820S		
R422SBR	00D 963 0345 903	R,FIXED 2WJ-0.47	N113136647820S		
R423SBL	00D 963 0345 903	R,FIXED 2WJ-0.47	N113136647820S		
R423SBR	00D 963 0345 903	R,FIXED 2WJ-0.47	N113136647820S		
R424SBL	00D 963 0345 903	R,FIXED 2WJ-0.47	N113136647820S		
R424SBR	00D 963 0345 903	R,FIXED 2WJ-0.47	N113136647820S		
R429SBL	00D 963 9006 256	R,FIXED 1WJ-10	N113135610020S		
R429SBR	00D 963 9006 256	R,FIXED 1WJ-10	N113135610020S		
R430SBL	00D 963 9006 256	R,FIXED 1WJ-10	N113135610020S		
R430SBR	00D 963 9006 256	R,FIXED 1WJ-10	N113135610020S		
VR401,402	00D 963 0366 407	VR,SEMI CARBON EVN-DCAA03B 1KB	C541102315000S		*
CAPACITORS GROUP					
C401D	00D 963 0021 900	C,FILM 0.047UF-J/100V	D02047306C060S		
C401H	00D 963 0021 900	C,FILM 0.047UF-J/100V	D02047306C060S		
C401SBL	00D 963 9006 544	C,ELECT 22UF-M/25V	D040220084050S		
C401SBR	00D 963 9006 544	C,ELECT 22UF-M/25V	D040220084050S		
C401X	nsp	C,CERAMIC 0.1UF-K/50V	D011104577160S		
C402D	00D 963 0021 900	C,FILM 0.047UF-J/100V	D02047306C060S		
C402H	00D 963 0021 900	C,FILM 0.047UF-J/100V	D02047306C060S		
C402SBL	00D 963 0234 205	C,ELECT 10UF-M/50V	D040100087070S		
C402SBR	00D 963 0234 205	C,ELECT 10UF-M/50V	D040100087070S		
C402X	00D 963 9003 097	C,FILM 0.1UF-K/250V	D02010407H080S		
C403D	00D 963 0021 900	C,FILM 0.047UF-J/100V	D02047306C060S		
C403H	00D 963 0021 900	C,FILM 0.047UF-J/100V	D02047306C060S		
C403SBL	00D 963 0367 101	C,CERAMIC 220PF-J/500V	D00422106D05CS		*
C403SBR	00D 963 0367 101	C,CERAMIC 220PF-J/500V	D00422106D05CS		*
C403X	00D 960 0133 404	C,ELECT 1000UF 16V	D040103083020S		
C404D	00D 960 0133 404	C,ELECT 1000UF 16V	D040103083020S		
C404H	00D 963 0217 002	C,ELECT 3300UF-M/16V	D040332083010S		
C404SBL	00D 963 0338 208	C,CERAMIC 470PF-K/500V	D00447127D050S		
C404SBR	00D 963 0338 208	C,CERAMIC 470PF-K/500V	D00447127D050S		
C404X	00D 963 0276 409	C,ELECT 100UF-M/16V	D040101083090S		
C405D	00D 963 0338 402	C,ELECT 330UF-M/6.3V	D040331081050S		
C405SBL	00D 963 0216 100	C,CERAMIC 33PF-J/500V	D00033006D050S		
C405SBR	00D 963 0216 100	C,CERAMIC 33PF-J/500V	D00033006D050S		
C406D	nsp	C,CERAMIC 0.1UF-K/50V	D011104577160S		
C406SBL	00D 963 0293 709	C,ELECT 100UF-M/10V	D040101082070S		
C406SBR	00D 963 0293 709	C,ELECT 100UF-M/10V	D040101082070S		
C406X	nsp	C,CERAMIC 1000PF-K/50V	D011102777160S		
C407D	nsp	C,CERAMIC 1000PF-K/50V	D011102777160S		

Ref. No.	Part No.	Part Name	Remarks	Q'ty	New
C407SBL	00D 963 9003 194	C,FILM 0.0022UF-J/100V	D02022206C060S		
C407SBR	00D 963 9003 194	C,FILM 0.0022UF-J/100V	D02022206C060S		
C407X	00D 963 0293 709	C,ELECT 100UF-M/10V	D040101082070S		
C408D	00D 963 0338 402	C,ELECT 330UF-M/6.3V	D040331081050S		
C408SBL	00D 963 0234 506	C,ELECT 47UF-M/50V (Pb Free)	D040470087070S		
C408SBR	00D 963 0234 506	C,ELECT 47UF-M/50V (Pb Free)	D040470087070S		
C408X	00D 963 0293 709	C,ELECT 100UF-M/10V	D040101082070S		
C409D	nsp	C,CERAMIC 0.1UF-K/50V	D011104577160S		
C409SBL	00D 963 9003 084	C,CERAMIC 100PF-K/500V	D00410106D050S		
C409SBR	00D 963 9003 084	C,CERAMIC 100PF-K/500V	D00410106D050S		
C410D	00D 963 0338 402	C,ELECT 330UF-M/6.3V	D040331081050S		
C410SBL	00D 963 0234 205	C,ELECT 10UF-M/50V	D040100087070S		
C410SBR	00D 963 0234 205	C,ELECT 10UF-M/50V	D040100087070S		
C411D	nsp	C,CERAMIC 0.1UF-K/50V	D011104577160S		
C411SBL	00D 963 9003 084	C,CERAMIC 100PF-K/500V	D00410106D050S		
C411SBR	00D 963 9003 084	C,CERAMIC 100PF-K/500V	D00410106D050S		
C412D	nsp	C,CERAMIC 0.1UF-K/50V	D011104577160S		
C412SBL	nsp	C,CERAMIC 0.022UF-K/25V	D011223777160S		
C412SBR	nsp	C,CERAMIC 0.022UF-K/25V	D011223777160S		
C413D	00D 963 0024 907	C,ELECT 1000UF-M/6.3V	D040102081060S		
C413SBL	00D 963 9003 097	C,FILM 0.1UF-K/250V	D02010407H080S		
C413SBR	00D 963 9003 097	C,FILM 0.1UF-K/250V	D02010407H080S		
C443	nsp	C,CERAMIC 1000PF-K/50V	D011102777160S		
OTHERS PARTS GROUP					
CLAMP401	nsp	CLAMP WIRE(SOLDER)	4330000120000S		
CN203	nsp	CN,WIRE 3P	L000181030010S		*
CN401A	nsp	CN,WIRE 5P	L000191050030S		*
CN405	nsp	CN,WIRE 5P	L000321050020S		*
CN705	nsp	CN,WIRE 3P	L000151030010S		
CN904	nsp	CN,WIRE 6P	L000141060030S		*
CP102	nsp	CN.WAFER 3P	L102526700300S		
CP201	nsp	CN.WAFER 6P	L101220060000S		
CP402	nsp	CN.WAFER 3P	L102526700300S		
L401SBL	nsp	COIL INDUCTOR 0.5UH	D330R50000000S		
L401SBR	nsp	COIL INDUCTOR 0.5UH	D330R50000000S		
TP401,402	nsp	CN.WAFER 3P ANGLE	L101530150310S		
	00D 963 0328 409	D,SWITCHING 1N4007	K000400700010S		

CPU P.W.B. UNIT ASS'Y

Ref. No.	Part No.	Part Name	Remarks	Q'ty	New
SEMICONDUCTORS GROUP					
IC712-715	00D 963 0024 004	IC NJM2068M		J121206800020S	
IC804	963243000020D	IC,CPU MICRO PROCESS	M30626FHPFP	8952150800015	
IC806	00D 960 0100 301	IC KIA7812API		J126781200040S	
IC813	00D 963 0367 204	IC SN74HC151PWR		J040741510070S	*
IC817	00D 963 0244 907	IC SN74LV14APWR		J040741400180S	
IC818	00D 963 0367 307	IC SN74AHCU04PWR		J040740400290S	*
IC824	00D 963 0043 807	IC BA4510F-E2/SOP8		J121451000010S	
IC827	00D 963 0043 807	IC BA4510F-E2/SOP8		J121451000010S	
IC830	00D 262 2813 903	SN74AHCT08PW-EL2 +C		J040740800190S	
Q704C	00D 963 0044 301	TR KTC2875B(MB)	<div style="border: 1px solid black; border-radius: 10px; padding: 5px;"> ファームウェアをアップデートするときは、SDIで最終バージョンを確認して下さい。サービス基板はアップデートして使用下さい。 When update Firmware, please confirm a last version in SDI. Use the service board after updating it. </div>	J5222875B0010S	
Q704FL	00D 963 0044 301	TR KTC2875B(MB)		J5222875B0010S	
Q704FR	00D 963 0044 301	TR KTC2875B(MB)		J5222875B0010S	
Q704SBL	00D 963 0044 301	TR KTC2875B(MB)		J5222875B0010S	
Q704SBR	00D 963 0044 301	TR KTC2875B(MB)		J5222875B0010S	
Q704SL	00D 963 0044 301	TR KTC2875B(MB)		J5222875B0010S	
Q704SR	00D 963 0044 301	TR KTC2875B(MB)		J5222875B0010S	
Q704SW	00D 963 0044 301	TR KTC2875B(MB)		J5222875B0010S	
Q801	00D 963 0120 704	TR KRA102S		J520010200210S	
Q802-805	00D 963 0044 301	TR KTC2875B(MB)		J5222875B0010S	
Q806	00D 963 0121 509	TR KTC3875S	J522038750210S		
Q807	00D 960 0285 006	TR KRC104S	J522104S00210S		
Q810D	00D 963 0245 100	D,SWITCHING KDS226ST1(C3)	K005022600020S		
Q811D	00D 963 0245 100	D,SWITCHING KDS226ST1(C3)	K005022600020S		
Q812D	00D 963 0120 801	TR KRC102S	J522010200210S		
Q813D	00D 963 0120 704	TR KRA102S	J520010200210S		
D801-804	00D 963 0355 401	D,SWITCHING KDS4148U	K005041480030S		
D805	00D 963 0328 409	D,SWITCHING 1N4007	K000400700010S		
D807	00D 963 0355 401	D,SWITCHING KDS4148U	K005041480030S		
D807D	00D 963 0355 401	D,SWITCHING KDS4148U	K005041480030S		
D808D	00D 963 0341 305	D,ESD IMSA-6802-01A	K067680200010S		
D809D	00D 963 0355 401	D,SWITCHING KDS4148U	K005041480030S		
D810D	00D 963 0341 305	D,ESD IMSA-6802-01A	K067680200010S		
D811D	00D 963 0341 305	D,ESD IMSA-6802-01A	K067680200010S		
ZD801	00D 963 0047 502	D,ZENER MTZJ3.3B	K06003R344520S		
RESISTORS GROUP					
R857	00D 960 9003 807	R,METAL FILM 100-J,1/4W		C060010163050S	
CAPACITORS GROUP					
C751C	00D 963 0234 205	C,ELECT 10UF-M/50V		D040100087070S	
C751FL	00D 963 0234 205	C,ELECT 10UF-M/50V		D040100087070S	
C751FR	00D 963 0234 205	C,ELECT 10UF-M/50V		D040100087070S	
C751SBL	00D 963 0234 205	C,ELECT 10UF-M/50V		D040100087070S	
C751SBR	00D 963 0234 205	C,ELECT 10UF-M/50V		D040100087070S	
C751SL	00D 963 0234 205	C,ELECT 10UF-M/50V		D040100087070S	
C751SR	00D 963 0234 205	C,ELECT 10UF-M/50V		D040100087070S	
C751SW	00D 963 0234 205	C,ELECT 10UF-M/50V		D040100087070S	
C752C	00D 963 0350 503	C,CERAMIC 390PF-J/50V		D010391167160S	
C752FL	00D 963 0223 708	C,CERAMIC 270PF-J/50V		D010271167160S	

Ref. No.	Part No.	Part Name	Remarks	Q'ty	New
C752FR	00D 963 0223 708	C,CERAMIC 270PF-J/50V	D010271167160S		
C752SBL	00D 960 9009 814	C,CERAMIC 330PF-J/50V	D010331167160S		
C752SBR	00D 960 9009 814	C,CERAMIC 330PF-J/50V	D010331167160S		
C752SL	00D 960 9009 814	C,CERAMIC 330PF-J/50V	D010331167160S		
C752SR	00D 960 9009 814	C,CERAMIC 330PF-J/50V	D010331167160S		
C752SW	00D 963 0350 503	C,CERAMIC 390PF-J/50V	D010391167160S		
C753C	00D 963 0224 008	C,CERAMIC 470PF-J/50V	D010471167160S		
C753FL	00D 963 0223 902	C,CERAMIC 39PF-J/50V	D010390167160S		
C753FR	00D 963 0223 902	C,CERAMIC 39PF-J/50V	D010390167160S		
C753SBL	00D 963 0223 708	C,CERAMIC 270PF-J/50V	D010271167160S		
C753SBR	00D 963 0223 708	C,CERAMIC 270PF-J/50V	D010271167160S		
C753SL	00D 963 0223 708	C,CERAMIC 270PF-J/50V	D010271167160S		
C753SR	00D 963 0223 708	C,CERAMIC 270PF-J/50V	D010271167160S		
C753SW	00D 963 0224 008	C,CERAMIC 470PF-J/50V	D010471167160S		
C755C	nsp	C,CERAMIC 0.1UF-Z/50V	D011104597160S		
C755FL	nsp	C,CERAMIC 0.1UF-Z/50V	D011104597160S		
C755FR	nsp	C,CERAMIC 0.1UF-Z/50V	D011104597160S		
C755SBL	nsp	C,CERAMIC 0.1UF-Z/50V	D011104597160S		
C755SBR	nsp	C,CERAMIC 0.1UF-Z/50V	D011104597160S		
C755SL	nsp	C,CERAMIC 0.1UF-Z/50V	D011104597160S		
C755SR	nsp	C,CERAMIC 0.1UF-Z/50V	D011104597160S		
C755SW	nsp	C,CERAMIC 0.1UF-Z/50V	D011104597160S		
C756C	00D 963 9003 194	C,FILM 0.0022UF-J/100V	D02022206C060S		
C756FL	00D 963 9003 194	C,FILM 0.0022UF-J/100V	D02022206C060S		
C756FR	00D 963 9003 194	C,FILM 0.0022UF-J/100V	D02022206C060S		
C756SBL	00D 963 9003 194	C,FILM 0.0022UF-J/100V	D02022206C060S		
C756SBR	00D 963 9003 194	C,FILM 0.0022UF-J/100V	D02022206C060S		
C756SL	00D 963 9003 194	C,FILM 0.0022UF-J/100V	D02022206C060S		
C756SR	00D 963 9003 194	C,FILM 0.0022UF-J/100V	D02022206C060S		
C756SW	00D 963 9003 194	C,FILM 0.0022UF-J/100V	D02022206C060S		
C757C	nsp	C,CERAMIC 10UF-Z/10V	D011106592200S		
C757FL	nsp	C,CERAMIC 10UF-Z/10V	D011106592200S		
C757FR	nsp	C,CERAMIC 10UF-Z/10V	D011106592200S		
C757SBL	nsp	C,CERAMIC 10UF-Z/10V	D011106592200S		
C757SBR	nsp	C,CERAMIC 10UF-Z/10V	D011106592200S		
C757SL	nsp	C,CERAMIC 10UF-Z/10V	D011106592200S		
C757SR	nsp	C,CERAMIC 10UF-Z/10V	D011106592200S		
C757SW	nsp	C,CERAMIC 10UF-Z/10V	D011106592200S		
C803	nsp	C,CERAMIC 100PF-J/50V	D010101167160S		
C804,805	nsp	C,CERAMIC 0.1UF-Z/50V	D011104597160S		
C806	nsp	C,CERAMIC 0.01UF-K/50V	D011103777160S		
C807,808	nsp	C,CERAMIC 0.022UF-Z/50V	D011223597160S		
C809	00D 963 0293 709	C,ELECT 100UF-M/10V	D040101082070S		
C810	nsp	C,CERAMIC 0.1UF-Z/50V	D011104597160S		
C813	nsp	C,CERAMIC 0.1UF-Z/50V	D011104597160S		
C814-816	nsp	C,CERAMIC 0.01UF-K/50V	D011103777160S		
C818	00D 960 9010 010	C,ELECT 4.7UF-M/50V	D0404R7087250S		
C819	nsp	C,CERAMIC 0.01UF-K/50V	D011103777160S		
C824,825	00D 963 0234 205	C,ELECT 10UF-M/50V	D040100087070S		
C826-831	nsp	C,CERAMIC 100PF-J/50V	D010101167160S		
C836,837	nsp	C,CERAMIC 0.022UF-Z/50V	D011223597160S		
C865L	nsp	C,CERAMIC 120PF-J/50V	D010121167160S		
C865R	nsp	C,CERAMIC 120PF-J/50V	D010121167160S		
C871L	00D 963 0216 304	C,FILM 0.001UF-J/100V	D02010206C060S		
C871R	00D 963 0216 304	C,FILM 0.001UF-J/100V	D02010206C060S		
C916D	nsp	C,CERAMIC 0.1UF-Z/50V	D011104597160S		

Ref. No.	Part No.	Part Name	Remarks	Q'ty	New
C917D	nsp	C,CERAMIC 0.1UF-Z/50V	D011104597160S		
C918D	nsp	C,CERAMIC 0.1UF-Z/50V	D011104597160S		
C921D	nsp	C,CERAMIC 100PF-J/50V	D010101167160S		
C923D	nsp	C,CERAMIC 22PF-J/50V	D010220167160S		
C924D	nsp	C,CERAMIC 22PF-J/50V	D010220167160S		
C927D	00D 963 9005 862	C,ELECT 47UF-M/16V	D040470083080S		
C928D	00D 963 9005 862	C,ELECT 47UF-M/16V	D040470083080S		
C931D	nsp	C,CERAMIC 100PF-J/50V	D010101167160S		
C932D	nsp	C,CERAMIC 0.01UF-K/50V	D011103777160S		
C933D	nsp	C,CERAMIC 0.01UF-K/50V	D011103777160S		
C934D	nsp	C,CERAMIC 0.01UF-K/50V	D011103777160S		
C935D	00D 960 9010 010	C,ELECT 4.7UF-M/50V	D0404R7087250S		
C936D	00D 960 9010 010	C,ELECT 4.7UF-M/50V	D0404R7087250S		
C937D	nsp	C,CERAMIC 1000PF-K/50V	D011102777160S		
C938D	00D 960 9010 010	C,ELECT 4.7UF-M/50V	D0404R7087250S		
C939D	nsp	C,CERAMIC 0.01UF-K/50V	D011103777160S		
C940D	nsp	C,CERAMIC 0.01UF-K/50V	D011103777160S		
C941D	00D 963 0244 606	C,ELECT 0.1UF-M/50V (Pb Free)	D040R10087080S		
C950D	nsp	C,CERAMIC 0.1UF-Z/50V	D011104597160S		
C951D	nsp	C,CERAMIC 0.1UF-Z/50V	D011104597160S		
C952D	00D 963 0234 205	C,ELECT 10UF-M/50V	D040100087070S		
C953D	00D 963 0234 205	C,ELECT 10UF-M/50V	D040100087070S		
C954D	nsp	C,CERAMIC 0.1UF-Z/50V	D011104597160S		
C955D	nsp	C,CERAMIC 0.1UF-Z/50V	D011104597160S		
C956D	nsp	C,CERAMIC 22PF-J/50V	D010220167160S		
C957D	nsp	C,CERAMIC 0.1UF-Z/50V	D011104597160S		
C959D	nsp	C,CERAMIC 22PF-J/50V	D010220167160S		
BC801	00D 254 4666 005	CE04W0H105ZC(FG)	00D2544666005		
OTHERS PARTS GROUP					
BD802-809	nsp	COIL,BEAD MB-160808	D340160800060S		
BD809D	nsp	COIL,BEAD MB-160808	D340160800060S		
BD810-817	nsp	COIL,BEAD MB-160808	D340160800060S		
CN105,106	nsp	CN.WAFER 5P	L101100030510S		
CN108	00D 963 0085 302	CN.WAFER 17P	L101100031710S		
CP01	nsp	CN.WAFER 16P	L101100041610S		
CP301A	00D 963 0367 400	CN.FPC 35P	L131524923520S		*
CP701	nsp	CN.WAFER 19P	L101100041910S		
CP702	nsp	CN.WAFER 15P	L100912150010S		*
CP703	nsp	CN.WAFER 8P	L101100040810S		
CP801	00D 963 0149 303	CN.FPC 15P	L131111500010S		
CP802	nsp	CN.WAFER 16P	L100912160010S		*
CP803	nsp	CN.WAFER 16P	L101100041610S		
CP804	nsp	CN.WAFER 15P	L100912150010S		*
CP805	nsp	CN.WAFER 08P	L100912080010S		
CP1001	nsp	CN.WAFER 8P	L101100040810S		
CP1002	nsp	CN.WAFER 9P	L101100040910S		
JACK801	00D 963 0217 905	TER,RCA 2PIN	G601206A0200YS		
JACK802	00D 963 0294 601	JACK,D3.5 EARPHONE	G40100350000YS		
L801D	nsp	COIL INDUCTOR 4.7UH	D3304R7000150S		

Ref. No.	Part No.	Part Name	Remarks	Q'ty	New
L802D	nsp	COIL INDUCTOR 4.7UH	D3304R7000150S		
L803D	nsp	COIL INDUCTOR 4.7UH	D3304R7000150S		
L805D	nsp	COIL INDUCTOR 4.7UH	D3304R7000150S		
L806D	nsp	COIL INDUCTOR 22UH	D330220010520S		
L807D	nsp	COIL INDUCTOR 22UH	D330220010520S		
TP803	nsp	CN.WAFER 8P	L101220080000S		
TP804	nsp	CN.WAFER 4P	L101220040000S		
X801	00D 963 0217 701	RESONATOR,CERAMIC ZTT12.00MT	E830120000060S		
OPT801D	00D 963 0237 503	MODULE JSR1165-C	E100116500040S		
OPT802D	00D 963 0237 503	MODULE JSR1165-C	E100116500040S		
	nsp	CN,WIRE 110MM/1P	L000111010010S		

HDMI P.W.B. UNIT ASS'Y

Ref. No.	Part No.	Part Name	Remarks	Q'ty	New
SEMICONDUCTORS GROUP					
IC01	nsp	SII9185CTU	00D2623721007		
IC03	nsp	IC SE1117-1.8	J126111718010S		
IC04	nsp	IC F2621E-01-PR	J080260200040S		
IC05	nsp	IC SE1117-33-PF	J126111733020S		
IC06	nsp	IC AK4385	J042438500010S		
IC07	nsp	IC SN74LVO8APW-EL2	J040740800200S		
IC08,09	nsp	IC SN74AHCT08-EL2	J040740800190S		
IC10	nsp	IC NJM2068M	J121206800020S		
IC11	nsp	IC KIA7805AF	J126780500450S		
IC12	nsp	IC BU4094BCF-E2	J040140940030S		
IC801	nsp	ADSP21367KSZ1A1136	00D2623709016		
IC802	nsp	W9864G2GH-7	00D2623746008		
IC803	nsp	IC EN29LV160AB	J005291600030S		
IC807	nsp	IC LC89057W-VF4A-E	J046890570030S		
IC808	nsp	ADAU1328BSTZ1136	00D2623645015		
IC809-811	nsp	IC SN74LVC244APWR	J040742440230S		
IC812	nsp	IC SN74HCT244PWR	J040742440220S		
IC814,815	nsp	IC SN74HCT00PWR	J040740000210S		
IC816	nsp	74LVX157MTC +C	00D2622870904		
IC823	nsp	IC KIA7805AF-RTF/P	J126780500450S		
IC825,826	nsp	IC SN74LVC74APWR	J040747400200S		
IC832	nsp	IC SE1117-33-PF	J126111733020S		
Q01,02	nsp	TR KRC102S	J522010200210S		
Q03,04	nsp	TR KRC104S	J522104S00210S		
Q07	nsp	TR KRC104S	J522104S00210S		
Q08	nsp	TR KRC102S	J522010200210S		
Q09	nsp	TR KRA104S	J520010400210S		
Q10,11	nsp	TR KRC102S	J522010200210S		
Q12,13	nsp	TR KRA102S	J520010200210S		
Q14-17	nsp	TR KTC2875B(MB)	J5222875B0010S		
Q18,19	nsp	TR KRC104S (ND)	J522104S00210S		
Q810D	nsp	TR KRC102S	J522010200210S		
Q811D	nsp	TR KRA102S	J520010200210S		
Q814D	nsp	TR KRA102S	J520010200210S		
D01-15	nsp	D,ESD IMSA-6802-01A	K067680200010S		
D17-32	nsp	D,ESD IMSA-6802-01A	K067680200010S		
D34-36	nsp	D,ESD IMSA-6802-01A	K067680200010S		
D37-44	nsp	D,SWITCHING KDS4148U	K005041480030S		
ZD101	nsp	D,ZENER 0.2W 5.1V UDZ	K06605R14P400S		
RESISTORS GROUP					
R41,42	nsp	COIL,BEAD MB-160808	D340160800060S		
R62	nsp	COIL,BEAD MB-160808	D340160800060S		
CAPACITORS GROUP					
C01	nsp	C,CERAMIC 1000PF-K/50V	D011102777160S		
C02-05	nsp	C,CERAMIC 0.1UF-K/50V	D011104577162S		
C06,07	nsp	C,CERAMIC 1000PF-K/50V	D011102777160S		
C08-14	nsp	C,CERAMIC 0.1UF-K/50V	D011104577162S		
C15-17	nsp	C,CERAMIC 1000PF-K/50V	D011102777160S		

Ref. No.	Part No.	Part Name	Remarks	Q'ty	New
C18,19	nsp	C,CERAMIC 0.1UF-K/50V	D011104577162S		
C20	nsp	C,CERAMIC 1000PF-K/50V	D011102777160S		
C21	nsp	C,CERAMIC 100PF-J/50V	D010101167160S		
C22	nsp	C,CERAMIC 1000PF-K/50V	D011102777160S		
C23	nsp	C,CERAMIC 100PF-J/50V	D010101167160S		
C24,25	nsp	C,ELECT 10UF-MVG/16V	D050100083460S		
C26,27	nsp	C,CERAMIC 0.01UF-K/50V	D011103777160S		
C28H	nsp	C,ELECT 10UF-MVG/16V	D050100083460S		
C29H	nsp	C,ELECT 10UF-MVG/16V	D050100083460S		
C30H	nsp	C,ELECT 10UF-MVG/16V	D050100083460S		
C33-36	nsp	C,CERAMIC 20PF-J/50V	D010200167160S		
C37-39	nsp	C,CERAMIC 0.1UF-K/50V	D011104577162S		
C40	nsp	C,ELECT 22UF-MV/6.3V	D050220081450S		
C41	nsp	C,CERAMIC 0.1UF-K/50V	D011104577162S		
C42,43	nsp	C,CERAMIC 5PF-C/50V	D010050107160S		
C44	nsp	C,CERAMIC 0.1UF-K/50V	D011104577162S		
C45	nsp	C,CERAMIC 1000PF-K/50V	D011102777160S		
C46	nsp	C,CERAMIC 4.7UF-K/10V	D011475572200S		
C47-50	nsp	C,CERAMIC 0.1UF-K/50V	D011104577162S		
C51	nsp	C,CERAMIC 1000PF-K/50V	D011102777160S		
C52	nsp	C,CERAMIC 0.1UF-K/50V	D011104577162S		
C53	nsp	C,ELECT 10UF-MVG/16V	D050100083460S		
C54	nsp	C,CERAMIC 0.1UF-K/50V	D011104577162S		
C55	nsp	C,CERAMIC 4.7UF-K/10V	D011475572200S		
C56,57	nsp	C,CERAMIC 1000PF-K/50V	D011102777160S		
C58	nsp	C,CERAMIC 0.1UF-K/50V	D011104577162S		
C59	nsp	C,CERAMIC 1000PF-K/50V	D011102777160S		
C60	nsp	C,CERAMIC 0.1UF-K/50V	D011104577162S		
C61	nsp	C,CERAMIC 1000PF-K/50V	D011102777160S		
C62	nsp	C,CERAMIC 0.1UF-K/50V	D011104577162S		
C63-65	nsp	C,CERAMIC 100PF-J/50V	D010101167160S		
C66	nsp	C,CERAMIC 0.01UF-K/50V	D011103777160S		
C68	nsp	C,ELECT 0.1UF-MVG/50V	D050R10080010S		
C69,70	nsp	C,CERAMIC 0.1UF-K/50V	D011104577162S		
C71,72	nsp	C,ELECT 22UF-MV/6.3V	D050220081450S		
C73,74	nsp	C,ELECT 10UF-MVG/16V	D050100083460S		
C75	nsp	C,CERAMIC 560PF-J/50V	D010561167160S		
C76	nsp	C,CERAMIC 1800PF-K/50V	D011182777160S		
C77,78	nsp	C,CERAMIC 560PF-J/50V	D010561167160S		
C79	nsp	C,CERAMIC 1800PF-K/50V	D011182777160S		
C80	nsp	C,CERAMIC 560PF-J/50V	D010561167160S		
C82	nsp	C,CERAMIC 1000PF-K/50V	D011102777160S		
C85,86	nsp	C,CERAMIC 0.047UF-Z/50V	D011473597160S		
C87,88	nsp	C,CERAMIC 0.01UF-K/50V	D011103777160S		
C831D	nsp	C,CERAMIC 0.1UF-K/50V	D011104577162S		
C832D	nsp	C,CERAMIC 1000PF-K/50V	D011102177101S		
C833D	nsp	C,CERAMIC 100PF-J/50V	D011101167101S		
C834D	nsp	C,CERAMIC 100PF-J/50V	D011101167101S		
C835D	nsp	C,CERAMIC 0.01UF-K/50V	D011103177101S		
C836D	nsp	C,CERAMIC 0.01UF-K/50V	D011103177101S		
C837D	nsp	C,CERAMIC 100PF-J/50V	D011101167101S		
C838D	nsp	C,CERAMIC 100PF-J/50V	D011101167101S		
C839D	nsp	C,CERAMIC 100PF-J/50V	D011101167101S		
C840D	nsp	C,CERAMIC 100PF-J/50V	D011101167101S		
C841D	nsp	C,CERAMIC 100PF-J/50V	D011101167101S		
C842D	nsp	C,CERAMIC 100PF-J/50V	D011101167101S		

Ref. No.	Part No.	Part Name	Remarks	Q'ty	New
C843D	nsp	C,CERAMIC 100PF-J/50V	D011101167101S		
C844D	nsp	C,CERAMIC 100PF-J/50V	D011101167101S		
C845D	nsp	C,CERAMIC 0.1UF-K/50V	D011104177101S		
C846D	nsp	C,CERAMIC 1000PF-K/50V	D011102177101S		
C847D	nsp	C,CERAMIC 1000PF-K/50V	D011102177101S		
C848D	nsp	C,CERAMIC 1000PF-K/50V	D011102177101S		
C849D	nsp	C,CERAMIC 1000PF-K/50V	D011102177101S		
C850D	nsp	C,CERAMIC 1000PF-K/50V	D011102177101S		
C851D	nsp	C,CERAMIC 1000PF-K/50V	D011102177101S		
C852D	nsp	C,CERAMIC 1000PF-K/50V	D011102177101S		
C853D	nsp	C,CERAMIC 1000PF-K/50V	D011102177101S		
C854D	nsp	C,CERAMIC 0.1UF-K/50V	D011104177101S		
C855D	nsp	C,CERAMIC 0.1UF-K/50V	D011104177101S		
C856D	nsp	C,CERAMIC 0.1UF-K/50V	D011104177101S		
C857D	nsp	C,CERAMIC 0.1UF-K/50V	D011104177101S		
C858D	nsp	C,CERAMIC 0.1UF-K/50V	D011104177101S		
C859D	nsp	C,CERAMIC 0.1UF-K/50V	D011104177101S		
C860D	nsp	C,CERAMIC 0.1UF-K/50V	D011104177101S		
C861D	nsp	C,CERAMIC 0.1UF-K/50V	D011104177101S		
C862D	nsp	C,CERAMIC 0.01UF-K/50V	D011103177101S		
C863D	nsp	C,CERAMIC 100PF-J/50V	D011101167101S		
C864D	nsp	C,CERAMIC 4.7UF-K/10V	D011475572200S		
C865D	nsp	C,CERAMIC 5PF-C/50V	D010050107160S		
C866D	nsp	C,CERAMIC 5PF-C/50V	D010050107160S		
C871D	nsp	C,CERAMIC 0.01UF-K/50V	D011103177101S		
C873D	nsp	C,CERAMIC 0.01UF-K/50V	D011103177101S		
C875D	nsp	C,CERAMIC 4.7UF-K/10V	D011475572200S		
C876D	nsp	C,CERAMIC 0.01UF-K/50V	D011103177101S		
C877D	nsp	C,CERAMIC 0.1UF-K/50V	D011104177101S		
C878D	nsp	C,CERAMIC 0.1UF-K/50V	D011104177101S		
C879D	nsp	C,CERAMIC 0.1UF-K/50V	D011104177101S		
C880D	nsp	C,CERAMIC 0.01UF-K/50V	D011103177101S		
C881D	nsp	C,CERAMIC 0.01UF-K/50V	D011103177101S		
C882D	nsp	C,CERAMIC 6PF-D/50V	D010060117160S		
C883D	nsp	C,CERAMIC 6PF-D/50V	D010060117160S		
C884D	nsp	C,CERAMIC 0.1UF-K/50V	D011104577162S		
C885D	nsp	C,CERAMIC 0.022UF-Z/50V	D011223597160S		
C886D	nsp	C,CERAMIC 0.1UF-K/50V	D011104177101S		
C887D	nsp	C,FILM 0.12UF-J/63V	D020124078060S		
C888D	nsp	C,CERAMIC 0.01UF-K/50V	D011103177101S		
C889D	nsp	C,CERAMIC 100PF-J/50V	D011101167101S		
C890D	nsp	C,CERAMIC 0.01UF-K/50V	D011103177101S		
C891D	nsp	C,CERAMIC 0.01UF-K/50V	D011103177101S		
C892D	nsp	C,CERAMIC 4.7UF-K/10V	D011475572200S		
C893D	nsp	C,CERAMIC 0.1UF-K/50V	D011104177101S		
C895D	nsp	C,CERAMIC 0.1UF-K/50V	D011104177101S		
C896D	nsp	C,CERAMIC 0.01UF-K/50V	D011103177101S		
C897D	nsp	C,CERAMIC 0.1UF-K/50V	D011104177101S		
C898D	nsp	C,CERAMIC 0.1UF-K/50V	D011104177101S		
C899D	nsp	C,CERAMIC 100PF-J/50V	D011101167101S		
C900D	nsp	C,CERAMIC 4.7UF-K/10V	D011475572200S		
C901D	nsp	C,ELECT 100UF-MVG/6.3V	D050101081650S		
C902D	nsp	C,CERAMIC 0.1UF-K/50V	D011104177101S		
C903D	nsp	C,CERAMIC 0.1UF-K/50V	D011104177101S		
C904D	nsp	C,CERAMIC 5600PF-K/50V	D011562777160S		
C905D	nsp	C,CERAMIC 390PF-J/50V	D010391167160S		

Ref. No.	Part No.	Part Name	Remarks	Q'ty	New
C906D	nsp	C,CERAMIC 0.1UF-K/50V	D011104177101S		
C907D	nsp	C,CERAMIC 0.1UF-K/50V	D011104177101S		
C908D	nsp	C,ELECT 47UF-MVG/6.3V	D050470081460S		
C909D	nsp	C,CERAMIC 0.1UF-K/50V	D011104177101S		
C910D	nsp	C,ELECT 10UF-MVG/16V	D050100083460S		
C911D	nsp	C,CERAMIC 0.01UF-K/50V	D011103177101S		
C913D	nsp	C,ELECT 10UF-MVG/16V	D050100083460S		
C914D	nsp	C,CERAMIC 0.01UF-K/50V	D011103177101S		
C915D	nsp	C,ELECT 10UF-MVG/16V	D050100083460S		
C916D	nsp	C,CERAMIC 0.1UF-K/50V	D011104577162S		
C917D	nsp	C,CERAMIC 0.1UF-K/50V	D011104577162S		
C918D	nsp	C,CERAMIC 0.1UF-K/50V	D011104577162S		
C919D	nsp	C,CERAMIC 0.1UF-K/50V	D011104577162S		
OTHERS PARTS GROUP					
BD801-804	nsp	COIL,BEAD MB-160808	D340160800060S		
BD807D	nsp	COIL,BEAD MB-160808	D340160800060S		
BD808D-02	nsp	COIL,BEAD MB-160808	D340160800060S		
CB03	nsp	R THICK 0-J,1/16W	C2000006M160S		
CB06	nsp	COIL,BEAD MB-160808	D340160800060S		
CN01	nsp	CN.WAFER 16P	L101100031610S		
CN802	nsp	CN.HOUSING 16P	L120912160010S		
CN803	nsp	CN.WAFER 16P	L101100031610S		
CN804	nsp	CN.HOUSING 15P	L120912150010S		
CN805	nsp	CN.HOUSING 08P	L120912080010S		
CP201	nsp	CN.WAFER 9P	L101220090000S		
CP404	nsp	CN.WAFER 4P	L101220040000S		
CP405	nsp	CN.WAFER 5P	L101220050000S		
CP406	nsp	CN.WAFER 3P	L101220030000S		
CP904	nsp	CN.WAFER 6P	L101220060010S		
J806	nsp	R,CHIP THICK 0-J,1/16W	C2000006M101S		
JACK01-03	00D 963 0388 504	19PIN HDMI CONNECTOR	L109100190020S		
JACK04	nsp	CAM-D96 4PIN SMALL COCNNETOR	L109040000020S		
X01	nsp	CRYSTAL CHIP FCX-02(45.1584MHz)	E80545R150020S		
X803D	nsp	FCX-03(16.660MHz)	00D3991091905		
X804D	nsp	FCX-03(24.576MHz)	00D3991053901		
LUG901	nsp	RING,TER WIRE 70MM/1P	8410700010070S		

VIDEO P.W.B. UNIT ASS'Y

Ref. No.	Part No.	Part Name	Remarks	Q'ty	New
SEMICONDUCTORS GROUP					
IC1001	00D 963 0133 500	IC BA7626FP	J171762600010S		
IC1002	00D 963 0068 002	IC BU4052BCF-E2	J040405200060S		
IC1003	00D 963 0074 504	IC BU2090F-E2	J044209000010S		
IC1005,1006	00D 963 0133 500	IC BA7626FP	J171762600010S		
IC1007	00D 963 0068 002	IC BU4052BCF-E2 P	J040405200060S		
IC1008	00D 963 0340 801	IC NJW1321FP1	J171132100010S		
IC1011,1012	00D 263 1082 903	TK15420MTL +C	J127154200010S		
IC1013	00D 963 0367 503	IC SE1117-1.8	J126111718010S		*
IC1014	00D 963 0111 603	IC SE1117-33-PF	J126111733020S		
IC1016	00D 963 0295 406	IC IC BH7868FS	J127786800000S		
IC1017	00D 262 3425 905	LTC4300-2CMS8	J040430000000S		
IC1018	00D 262 3643 004	ADV7180BSTZ	J044718000010S		
IC1019	00D 262 3644 003	ADV7172KSTZ	J045717200011S		
IC1151	00D 263 1082 903	TK15420MTL +C	J127154200010S		
IC1157	00D 263 1082 903	TK15420MTL +C	J127154200010S		
IC1160	00D 263 1082 903	TK15420MTL +C	J127154200010S		
IC1162,1163	00D 263 1082 903	TK15420MTL +C	J127154200010S		
IC1164	00D 963 0327 604	IC NJM2581M	J127258100010S		
Q1001	00D 963 0148 508	TRKTA1504S	J520015040150S		
Q1002	00D 960 0296 309	TR KRC111S (NM)	J522011100210S		
Q1003,1004	00D 963 0120 704	TR KRA102S	J520010200210S		
Q1005,1006	00D 963 0102 803	TR 2SA933S	J5000933S0050S		
Q1011,1012	00D 963 0120 704	TR KRA102S	J520010200210S		
Q1013,1014	00D 963 0148 508	TRKTA1504S	J520015040150S		
Q1015,1016	00D 960 0296 309	TR KRC111S (NM)	J522011100210S		
Q1017	00D 963 0120 801	TR KRC102S	J522010200210S		
Q1018	00D 963 0121 606	TR KRC107S	J522107S00210S		
Q1019	00D 963 0102 803	TR 2SA933S	J5000933S0050S		
Q1020	00D 960 0285 006	TR KRC104S	J522104S00210S		
Q1021-1025	00D 963 0148 508	TRKTA1504S	J520015040150S		
Q1026	00D 960 0285 006	TR KRC104S	J522104S00210S		
D1001	00D 963 0355 401	D,SWITCHING KDS4148U	K005041480030S		
D1005	00D 963 0355 401	D,SWITCHING KDS4148U	K005041480030S		
D1009,1010	00D 963 9006 599	R,CHIP THICK 0-J,1/10W	C200000060200S		
D1011-1014	00D 963 0355 401	D,SWITCHING KDS4148U	K005041480030S		
D1021-1024	00D 963 0355 401	D,SWITCHING KDS4148U	K005041480030S		
RESISTORS GROUP					
R1008	00D 963 9005 639	R,METAL FILM 100-J,1W	C060010165060S		
R1096	00D 963 9005 639	R,METAL FILM 100-J,1W	C060010165060S		
R1100	00D 963 9005 639	R,METAL FILM 100-J,1W	C060010165060S		
VR1001-1005	00D 963 0367 606	R,CHIP THICK 100ohm 1/16W	C20001014M160S		
CAPACITORS GROUP					
C1002-1004	00D 963 9006 544	C,ELECT 22UF-M/25V	D040220084050S		
C1005	00D 960 0298 802	C,ELECT 470UF-M/6.3V	D040471081070S		
C1006	00D 963 0234 205	C,ELECT 10UF-M/50V	D040100087070S		
C1007,1008	nsp	C,CERAMIC 0.01UF-K/50V	D011103777160S		
C1009	00D 963 0293 602	C,ELECT 1UF-M/50V (Pb Free)	D040010087150S		

Ref. No.	Part No.	Part Name	Remarks	Q'ty	New
C1010	00D 963 0293 709	C,ELECT 100UF-M/10V	D040101082070S		
C1011	nsp	C,CERAMIC 0.047UF-Z/50V	D011473597160S		
C1012,1013	nsp	C,CERAMIC 0.01UF-K/50V	D011103777160S		
C1014,1015	nsp	C,CERAMIC 100PF-J/50V	D010101167160S		
C1016,1017	nsp	C,CERAMIC 0.01UF-K/50V	D011103777160S		
C1018	00D 963 0293 709	C,ELECT 100UF-M/10V	D040101082070S		
C1019,1020	00D 963 9006 544	C,ELECT 22UF-M/25V	D040220084050S		
C1021	00D 963 0293 709	C,ELECT 100UF-M/10V	D040101082070S		
C1022	nsp	C,CERAMIC 0.01UF-K/50V	D011103777160S		
C1023-1025	00D 963 0293 709	C,ELECT 100UF-M/10V	D040101082070S		
C1026	nsp	C,CERAMIC 0.01UF-K/50V	D011103777160S		
C1027,1028	00D 963 9006 544	C,ELECT 22UF-M/25V	D040220084050S		
C1029,1030	nsp	C,CERAMIC 0.01UF-K/50V	D011103777160S		
C1032,1033	00D 963 0234 205	C,ELECT 10UF-M/50V	D040100087070S		
C1035,1036	00D 963 0294 106	C,ELECT 2.2UF-M/50V (Pb Free)	D0402R2087160S		
C1037	nsp	C,CERAMIC 0.01UF-K/50V	D011103777160S		
C1038,1039	00D 963 0234 205	C,ELECT 10UF-M/50V	D040100087070S		
C1041	00D 960 0298 802	C,ELECT 470UF-M/6.3V	D040471081070S		
C1042	00D 960 9010 023	C,ELECT 0.47UF-M/50V	D040R47087050S		
C1043,1044	00D 963 0234 205	C,ELECT 10UF-M/50V	D040100087070S		
C1045-1050	00D 963 9006 544	C,ELECT 22UF-M/25V	D040220084050S		
C1051,1052	nsp	C,CERAMIC 0.01UF-K/50V	D011103777160S		
C1053,1054	00D 963 0293 602	C,ELECT 1UF-M/50V (Pb Free)	D040010087150S		
C1055,1056	nsp	C,CERAMIC 0.047UF-Z/50V	D011473597160S		
C1057,1058	nsp	C,CERAMIC 0.01UF-K/50V	D011103777160S		
C1059,1060	00D 963 0223 009	R,THICK 0-J,1/16W	C20000006M160S		
C1061-1069	nsp	C,CERAMIC 0.1UF-K/50V	D011104577160S		
C1070-1078	00D 963 0234 205	C,ELECT 10UF-M/50V	D040100087070S		
C1079-1082	nsp	C,CERAMIC 0.1UF-K/50V	D011104577160S		
C1083	00D 963 0276 409	C,ELECT 100UF-M/16V	D040101083090S		
C1084,1085	nsp	C,CERAMIC 0.1UF-K/50V	D011104577160S		
C1086	00D 963 0234 205	C,ELECT 10UF-M/50V	D040100087070S		
C1087	nsp	C,CERAMIC 0.1UF-K/50V	D011104577160S		
C1088	00D 963 0234 205	C,ELECT 10UF-M/50V	D040100087070S		
C1089	nsp	C,CERAMIC 0.1UF-K/50V	D011104577160S		
C1090	00D 963 0234 205	C,ELECT 10UF-M/50V	D040100087070S		
C1091	nsp	C,CERAMIC 0.1UF-K/50V	D011104577160S		
C1092	00D 963 0276 409	C,ELECT 100UF-M/16V	D040101083090S		
C1093	00D 963 0293 602	C,ELECT 1UF-M/50V (Pb Free)	D040010087150S		
C1094	nsp	C,CERAMIC 0.047UF-Z/50V	D011473597160S		
C1095-1097	nsp	C,CERAMIC 0.01UF-K/50V	D011103777160S		
C1098	00D 963 0293 602	C,ELECT 1UF-M/50V (Pb Free)	D040010087150S		
C1099-1101	00D 963 0293 709	C,ELECT 100UF-M/10V	D040101082070S		
C1102	nsp	C,CERAMIC 0.01UF-K/50V	D011103777160S		
C1103	00D 963 9006 544	C,ELECT 22UF-M/25V	D040220084050S		
C1104	00D 963 0293 709	C,ELECT 100UF-M/10V	D040101082070S		
C1105	00D 963 9006 544	C,ELECT 22UF-M/25V	D040220084050S		
C1106	00D 963 0293 709	C,ELECT 100UF-M/10V	D040101082070S		
C1107	00D 963 9006 544	C,ELECT 22UF-M/25V	D040220084050S		
C1108,1109	00D 963 0293 709	C,ELECT 100UF-M/10V	D040101082070S		
C1113	00D 963 0144 706	C,FILM 0.01UF-J/50V	D020103167050S		
C1114	nsp	C,CERAMIC 100PF-J/50V	D010101167160S		
C1115	00D 963 0130 105	C,FILM 1UF-K/63V	D020105078060S		
C1116	nsp	C,CERAMIC 0.01UF-K/50V	D011103777160S		
C1117	nsp	C,CERAMIC 100PF-J/50V	D010101167160S		
C1118	00D 963 0024 907	C,ELECT 1000UF-M/6.3V	D040102081060S		

Ref. No.	Part No.	Part Name	Remarks	Q'ty	New
C1119,1120	nsp	C,CERAMIC 0.1UF-K/50V	D011104577160S		
C1121,1122	00D 963 0234 108	C,FILM 0.1UF-J/50V	D020104167050S		
C1123	nsp	C,CERAMIC 0.047UF-Z/50V	D011473597160S		
C1124-1126	00D 963 0234 205	C,ELECT 10UF-M/50V	D040100087070S		
C1127	00D 963 9006 544	C,ELECT 22UF-M/25V	D040220084050S		
C1128	00D 963 0234 205	C,ELECT 10UF-M/50V	D040100087070S		
C1129,1130	00D 963 9006 557	C,ELECT 220UF-M/6.3V	D040221081060S		
C1131	00D 963 0324 403	C,ELECT 33UF-M/35V	D040330085050S		
C1132,1133	00D 963 0144 706	C,FILM 0.01UF-J/50V	D020103167050S		
C1134	00D 960 0298 802	C,ELECT 470UF-M/6.3V	D040471081070S		
C1135	00D 963 0144 706	C,FILM 0.01UF-J/50V	D020103167050S		
C1136,1137	nsp	C,CERAMIC 0.1UF-K/50V	D011104577160S		
C1138	00D 963 0234 205	C,ELECT 10UF-M/50V	D040100087070S		
C1139,1140	nsp	C,CERAMIC 0.1UF-K/50V	D011104577160S		
C1141	nsp	C,CERAMIC 0.01UF-K/50V	D011103777160S		
C1142	00D 963 0234 108	C,FILM 0.1UF-J/50V	D020104167050S		
C1143	nsp	C,CERAMIC 0.1UF-K/50V	D011104577160S		
C1144	00D 963 0324 403	C,ELECT 33UF-M/35V	D040330085050S		
C1145	00D 960 0298 802	C,ELECT 470UF-M/6.3V	D040471081070S		
C1146	nsp	C,CERAMIC 1000PF-K/50V	D011102777160S		
C1147	nsp	C,CERAMIC 0.01UF-K/50V	D011103777160S		
C1148	00D 963 0324 403	C,ELECT 33UF-M/35V	D040330085050S		
C1149	nsp	C,CERAMIC 0.1UF-K/50V	D011104577160S		
C1150	nsp	C,CERAMIC 0.01UF-K/50V	D011103777160S		
C1151	nsp	C,CERAMIC 0.1UF-K/50V	D011104577160S		
C1152	00D 963 0303 000	C,CERAMIC 0.082UF-K/50V	D010823777160S		
C1153	nsp	C,CERAMIC 0.01UF-K/50V	D011103777160S		
C1154	nsp	C,CERAMIC 1000PF-K/50V	D011102777160S		
C1155	nsp	C,CERAMIC 0.01UF-K/50V	D011103777160S		
C1156,1157	00D 963 0234 108	C,FILM 0.1UF-J/50V	D020104167050S		
C1158	nsp	C,CERAMIC 0.1UF-K/50V	D011104577160S		
C1159	nsp	C,CERAMIC 1000PF-K/50V	D011102777160S		
C1160	nsp	C,CERAMIC 100PF-J/50V	D010101167160S		
C1161	nsp	C,CERAMIC 1000PF-K/50V	D011102777160S		
C1162	nsp	C,CERAMIC 0.1UF-K/50V	D011104577160S		
C1163	nsp	C,CERAMIC 100PF-J/50V	D010101167160S		
C1164,1165	nsp	C,CERAMIC 47PF-J/50V	D010470167160S		
C1166,1167	nsp	C,CERAMIC 0.1UF-K/50V	D011104577160S		
C1168	nsp	C,CERAMIC 1000PF-K/50V	D011102777160S		
C1169	nsp	C,CERAMIC 0.01UF-K/50V	D011103777160S		
C1170	nsp	C,CERAMIC 0.1UF-K/50V	D011104577160S		
C1171	nsp	C,CERAMIC 1000PF-K/50V	D011102777160S		
C1172,1173	00D 960 0298 802	C,ELECT 470UF-M/6.3V	D040471081070S		
C1174-1176	00D 963 0234 108	C,FILM 0.1UF-J/50V	D020104167050S		
C1177	nsp	C,CERAMIC 0.01UF-K/50V	D011103777160S		
C1178	nsp	C,CERAMIC 0.1UF-K/50V	D011104577160S		
C1179	nsp	C,CERAMIC 1000PF-K/50V	D011102777160S		
C1180	nsp	C,CERAMIC 0.1UF-K/50V	D011104577160S		
C1181,1182	nsp	C,CERAMIC 1000PF-K/50V	D011102777160S		
C1183	nsp	C,CERAMIC 0.1UF-K/50V	D011104577160S		
C1184	nsp	C,CERAMIC 100PF-J/50V	D010101167160S		
C1185	nsp	C,CERAMIC 1000PF-K/50V	D011102777160S		
C1186	nsp	C,CERAMIC 100PF-J/50V	D010101167160S		
C1187-1189	nsp	C,CERAMIC 0.1UF-K/50V	D011104577160S		
C1190,1191	nsp	C,CERAMIC 1000PF-K/50V	D011102777160S		
C1192-1194	nsp	C,CERAMIC 0.1UF-K/50V	D011104577160S		

Ref. No.	Part No.	Part Name	Remarks	Q'ty	New
C1198-1200	nsp	C,CERAMIC 0.01UF-K/50V	D011103777160S		
C1201,1202	00D 963 0324 403	C,ELECT 33UF-M/35V	D040330085050S		
C1203-1206	nsp	C,CERAMIC 0.01UF-K/50V	D011103777160S		
C1207	00D 963 0276 409	C,ELECT 100UF-M/16V	D040101083090S		
C1208	nsp	C,CERAMIC 0.01UF-K/50V	D011103777160S		
C1209	00D 963 0276 409	C,ELECT 100UF-M/16V	D040101083090S		
C1210	nsp	C,CERAMIC 0.01UF-K/50V	D011103777160S		
C1211	00D 963 0276 409	C,ELECT 100UF-M/16V	D040101083090S		
OTHERS PARTS GROUP					
BD1001-1003	nsp	COIL,BEAD MB-160808	D340160800060S		
CN406	nsp	CN,WIRE 3P	L000301030060S		
CN1001	nsp	CN.WAFER 8P	L101100030810S		
CN1002	nsp	CN.WAFER 9P	L101100030910S		
CP514	nsp	CN.WAFER 8P	L101220080010S		
JACK1001,1002	00D 963 0367 709	TER,RCA 6PIN	G603610D0032YS		*
JACK1003	00D 963 0218 001	TER,RCA 2PIN	G60122001000YS		
JACK1004	00D 963 0218 108	TER,RCA 3PIN	G60630401000YS		
L1003-1006	nsp	COIL INDUCTOR 22UH	D330220010520S		
X1011	00D 963 0294 407	CRYSTAL 28.63636MHZ	E80028R636010S		

HDMI_PWR P.W.B. UNIT ASS'Y

Ref. No.	Part No.	Part Name	Remarks	Q'ty	New
SEMICONDUCTORS GROUP					
IC401H1	00D 963 0366 500	IC KIA1117PI33	J126111733050S		
CAPACITORS GROUP					
C405H1	00D 963 0234 205	C,ELECT 10UF-M/50V	D040100087070S		
C406H1	00D 963 0233 303	C,CERAMIC 0.01UF-M/16V	D005103773530S		
OTHERS PARTS GROUP					
CN404	nsp	CN,WIRE 300MM/4P	L000301040110S		
CP513	nsp	CN.WAFER 3P ANGLE	L102526803010S		

PARTS LIST OF P.W.B. UNIT



AVR-1708 E2 MODEL

* 本表に "nsp" と記載されている部品は供給できません。

* Parts for which "nsp" is indicated on this table cannot be supplied.

* 本表に記載されている部品は、補修用部品のため製品に使用している部品とは一部、形状、寸法などが異なる場合があります。

* The parts listed below are for maintenance only, might differ from the parts used in the unit in appearances or dimensions.

MAIN P.W.B. UNIT ASS'Y

Ref. No.	Part No.	Part Name	Remarks	Q'ty	New
SEMICONDUCTORS GROUP					
	IC110,111	00D 963 0218 807	IC BU4094BCF-E2	J040140940030S	
	Q101	00D 960 0196 302	TR KTA1268BL	J5001268B0050S	
	Q102-104	00D 960 0196 700	TR KTC3200BL	J5023200B0050S	
	Q104C	00D 960 0196 506	TR KSC1845F	J5021845F0000S	
	Q104FL	00D 960 0196 506	TR KSC1845F	J5021845F0000S	
	Q104FR	00D 960 0196 506	TR KSC1845F	J5021845F0000S	
	Q104SL	00D 960 0196 506	TR KSC1845F	J5021845F0000S	
	Q104SR	00D 960 0196 506	TR KSC1845F	J5021845F0000S	
	Q105	00D 960 0196 700	TR KTC3200BL	J5023200B0050S	
	Q105C	00D 960 0196 603	TR KTC2874B	J502287400010S	
	Q105FL	00D 960 0196 603	TR KTC2874B	J502287400010S	
	Q105FR	00D 960 0196 603	TR KTC2874B	J502287400010S	
	Q105SL	00D 960 0196 603	TR KTC2874B	J502287400010S	
	Q105SR	00D 960 0196 603	TR KTC2874B	J502287400010S	
	Q106	00D 960 0196 700	TR KTC3200BL	J5023200B0050S	
	Q106C	00D 960 0196 205	TR KSA992F	J5000992F0050S	
	Q106FL	00D 960 0196 205	TR KSA992F	J5000992F0050S	
	Q106FR	00D 960 0196 205	TR KSA992F	J5000992F0050S	
	Q106SL	00D 960 0196 205	TR KSA992F	J5000992F0050S	
	Q106SR	00D 960 0196 205	TR KSA992F	J5000992F0050S	
	Q107	00D 960 0196 700	TR KTC3200BL	J5023200B0050S	
	Q107C	00D 960 0196 205	TR KSA992F	J5000992F0050S	
	Q107FL	00D 960 0196 205	TR KSA992F	J5000992F0050S	
	Q107FR	00D 960 0196 205	TR KSA992F	J5000992F0050S	
	Q107SL	00D 960 0196 205	TR KSA992F	J5000992F0050S	
	Q107SR	00D 960 0196 205	TR KSA992F	J5000992F0050S	
	Q108	00D 960 0196 700	TR KTC3200BL	J5023200B0050S	
	Q108C	00D 960 0196 506	TR KSC1845F	J5021845F0000S	
	Q108FL	00D 960 0196 506	TR KSC1845F	J5021845F0000S	
	Q108FR	00D 960 0196 506	TR KSC1845F	J5021845F0000S	
	Q108SL	00D 960 0196 506	TR KSC1845F	J5021845F0000S	
	Q108SR	00D 960 0196 506	TR KSC1845F	J5021845F0000S	
	Q109,110	00D 960 0196 700	TR KTC3200BL	J5023200B0050S	
	Q111	00D 960 0196 302	TR KTA1268BL	J5001268B0050S	
	Q130	00D 960 0196 302	TR KTA1268BL	J5001268B0050S	
	Q131,132	00D 963 0219 602	TR KRC106M	J6020106M0010S	
	Q133-137	00D 960 0097 207	TR KRA102M	J6002202M0010S	
	Q141SW	00D 963 0044 301	TR KTC2875B(MB)	J5222875B0010S	
	Q142	00D 960 0196 700	TR KTC3200BL	J5023200B0050S	
	Q142SW	00D 963 0044 301	TR KTC2875B(MB)	J5222875B0010S	
	Q143,144	00D 960 0196 302	TR KTA1268BL	J5001268B0050S	
	Q145	00D 960 0196 700	TR KTC3200BL	J5023200B0050S	
	Q146,147	00D 960 0196 302	TR KTA1268BL	J5001268B0050S	
	Q151	00D 960 0196 302	TR KTA1268BL	J5001268B0050S	
	Q156	00D 960 0097 304	TR KRC102M	J6020102M0010S	
	Q165	00D 960 0196 700	TR KTC3200BL	J5023200B0050S	
	Q166-171	00D 960 0196 302	TR KTA1268BL	J5001268B0050S	

Ref. No.	Part No.	Part Name	Remarks	Q'ty	New
Q541	00D 963 0121 208	TR KRC107M	J6020107M0010S		
D101C	00D 963 0355 401	D,SWITCHING KDS4148U	K005041480030S		
D101FL	00D 963 0355 401	D,SWITCHING KDS4148U	K005041480030S		
D101FR	00D 963 0355 401	D,SWITCHING KDS4148U	K005041480030S		
D101SL	00D 963 0355 401	D,SWITCHING KDS4148U	K005041480030S		
D101SR	00D 963 0355 401	D,SWITCHING KDS4148U	K005041480030S		
D102C	00D 963 0355 401	D,SWITCHING KDS4148U	K005041480030S		
D102FL	00D 963 0355 401	D,SWITCHING KDS4148U	K005041480030S		
D102FR	00D 963 0355 401	D,SWITCHING KDS4148U	K005041480030S		
D102SL	00D 963 0355 401	D,SWITCHING KDS4148U	K005041480030S		
D102SR	00D 963 0355 401	D,SWITCHING KDS4148U	K005041480030S		
D105C	00D 963 0020 309	D,SWITCHING 1SS133T	K000013300520S		
D105FL	00D 963 0020 309	D,SWITCHING 1SS133T	K000013300520S		
D105FR	00D 963 0020 309	D,SWITCHING 1SS133T	K000013300520S		
D105SL	00D 963 0020 309	D,SWITCHING 1SS133T	K000013300520S		
D105SR	00D 963 0020 309	D,SWITCHING 1SS133T	K000013300520S		
D106,107	00D 963 0355 401	D,SWITCHING KDS4148U	K005041480030S		
D114,115	00D 960 0197 107	D,RECTIFIER BRIDGE KBPC604	K047604000020S		
D139	00D 963 0020 309	D,SWITCHING 1SS133T	K000013300520S		
D140,141	00D 963 0328 409	D,SWITCHING 1N4007	K000400700010S		
D142	00D 963 0355 401	D,SWITCHING KDS4148U	K005041480030S		
D143-152	00D 963 0020 309	D,SWITCHING 1SS133T	K000013300520S		
D153	00D 963 0355 401	D,SWITCHING KDS4148U	K005041480030S		
D154-157	00D 963 0020 309	D,SWITCHING 1SS133T	K000013300520S		
D541	00D 963 0355 401	D,SWITCHING KDS4148U	K005041480030S		
ZD101	00D 963 0058 601	D,ZENER MTZJ12B	K06012R044520S		
ZD101C	00D 963 0367 008	D,ZENER 0.2W 3.3V UDZ	K06603R34P400S		
ZD101FL	00D 963 0367 008	D,ZENER 0.2W 3.3V UDZ	K06603R34P400S		
ZD101FR	00D 963 0367 008	D,ZENER 0.2W 3.3V UDZ	K06603R34P400S		
ZD101SL	00D 963 0367 008	D,ZENER 0.2W 3.3V UDZ	K06603R34P400S		
ZD101SR	00D 963 0367 008	D,ZENER 0.2W 3.3V UDZ	K06603R34P400S		
ZD102C	00D 963 0367 008	D,ZENER 0.2W 3.0V UDZ	K06603R04P400S		
ZD102FL	00D 963 0367 008	D,ZENER 0.2W 3.0V UDZ	K06603R04P400S		
ZD102FR	00D 963 0367 008	D,ZENER 0.2W 3.0V UDZ	K06603R04P400S		
ZD102SL	00D 963 0367 008	D,ZENER 0.2W 3.0V UDZ	K06603R04P400S		
ZD102SR	00D 963 0367 008	D,ZENER 0.2W 3.0V UDZ	K06603R04P400S		
ZD105	00D 960 0095 500	D,ZENER MTZJ5.1B	K06005R144520S		
RESISTORS GROUP					
R101	00D 963 0337 801	R,METAL FILM 100-J,2W	C060010166520S		
R103	00D 963 9005 639	R,METAL FILM 100-J,1W	C060010165060S		
R104	00D 963 0215 907	R,METAL FILM 4.7-J,1W	C0604R7065050S		
R104C	00D 963 9006 285	R,FIXED 1WJ-5.6K	N113135656220S		
R104FL	00D 963 9006 285	R,FIXED 1WJ-5.6K	N113135656220S		
R104FR	00D 963 9006 285	R,FIXED 1WJ-5.6K	N113135656220S		
R104SL	00D 963 9006 285	R,FIXED 1WJ-5.6K	N113135656220S		
R104SR	00D 963 9006 285	R,FIXED 1WJ-5.6K	N113135656220S		
R105	00D 963 0232 906	R,METAL FILM 47K-F,1/4W	C060047343530S		
R105C	00D 963 9006 285	R,FIXED 1WJ-5.6K	N113135656220S		
R105FL	00D 963 9006 285	R,FIXED 1WJ-5.6K	N113135656220S		
R105FR	00D 963 9006 285	R,FIXED 1WJ-5.6K	N113135656220S		
R105SL	00D 963 9006 285	R,FIXED 1WJ-5.6K	N113135656220S		
R105SR	00D 963 9006 285	R,FIXED 1WJ-5.6K	N113135656220S		

Ref. No.	Part No.	Part Name	Remarks	Q'ty	New
R106C	00D 963 0215 907	R,METAL FILM 4.7-J,1W	C0604R7065050S		
R106FL	00D 963 0215 907	R,METAL FILM 4.7-J,1W	C0604R7065050S		
R106FR	00D 963 0215 907	R,METAL FILM 4.7-J,1W	C0604R7065050S		
R106SL	00D 963 0215 907	R,METAL FILM 4.7-J,1W	C0604R7065050S		
R106SR	00D 963 0215 907	R,METAL FILM 4.7-J,1W	C0604R7065050S		
R107C	00D 963 0215 907	R,METAL FILM 4.7-J,1W	C0604R7065050S		
R107FL	00D 963 0215 907	R,METAL FILM 4.7-J,1W	C0604R7065050S		
R107FR	00D 963 0215 907	R,METAL FILM 4.7-J,1W	C0604R7065050S		
R107SL	00D 963 0215 907	R,METAL FILM 4.7-J,1W	C0604R7065050S		
R107SR	00D 963 0215 907	R,METAL FILM 4.7-J,1W	C0604R7065050S		
R108C	00D 963 0345 903	R,FIXED 2WJ-0.47	N113136647820S		
R108FL	00D 963 0345 903	R,FIXED 2WJ-0.47	N113136647820S		
R108FR	00D 963 0345 903	R,FIXED 2WJ-0.47	N113136647820S		
R108SL	00D 963 0345 903	R,FIXED 2WJ-0.47	N113136647820S		
R108SR	00D 963 0345 903	R,FIXED 2WJ-0.47	N113136647820S		
R109C	00D 963 0345 903	R,FIXED 2WJ-0.47	N113136647820S		
R109FL	00D 963 0345 903	R,FIXED 2WJ-0.47	N113136647820S		
R109FR	00D 963 0345 903	R,FIXED 2WJ-0.47	N113136647820S		
R109SL	00D 963 0345 903	R,FIXED 2WJ-0.47	N113136647820S		
R109SR	00D 963 0345 903	R,FIXED 2WJ-0.47	N113136647820S		
R110C	00D 963 0345 903	R,FIXED 2WJ-0.47	N113136647820S		
R110FL	00D 963 0345 903	R,FIXED 2WJ-0.47	N113136647820S		
R110FR	00D 963 0345 903	R,FIXED 2WJ-0.47	N113136647820S		
R110SL	00D 963 0345 903	R,FIXED 2WJ-0.47	N113136647820S		
R110SR	00D 963 0345 903	R,FIXED 2WJ-0.47	N113136647820S		
R111C	00D 963 0345 903	R,FIXED 2WJ-0.47	N113136647820S		
R111FL	00D 963 0345 903	R,FIXED 2WJ-0.47	N113136647820S		
R111FR	00D 963 0345 903	R,FIXED 2WJ-0.47	N113136647820S		
R111SL	00D 963 0345 903	R,FIXED 2WJ-0.47	N113136647820S		
R111SR	00D 963 0345 903	R,FIXED 2WJ-0.47	N113136647820S		
R117,118	00D 963 0144 502	R,CEMENT 0.1-J 5W	C141R10069000S		
R118C	00D 963 9006 256	R,FIXED 1WJ-10	N113135610020S		
R118FL	00D 963 9006 256	R,FIXED 1WJ-10	N113135610020S		
R118FR	00D 963 9006 256	R,FIXED 1WJ-10	N113135610020S		
R118SL	00D 963 9006 256	R,FIXED 1WJ-10	N113135610020S		
R118SR	00D 963 9006 256	R,FIXED 1WJ-10	N113135610020S		
R119C	00D 963 9006 256	R,FIXED 1WJ-10	N113135610020S		
R119FL	00D 963 9006 256	R,FIXED 1WJ-10	N113135610020S		
R119FR	00D 963 9006 256	R,FIXED 1WJ-10	N113135610020S		
R119SL	00D 963 9006 256	R,FIXED 1WJ-10	N113135610020S		
R119SR	00D 963 9006 256	R,FIXED 1WJ-10	N113135610020S		
R127C	00D 963 9005 642	R,METAL FILM 1.2K-J,1W	C060012265050S		
R127FL	00D 963 9005 642	R,METAL FILM 1.2K-J,1W	C060012265050S		
R127FR	00D 963 9005 642	R,METAL FILM 1.2K-J,1W	C060012265050S		
R127SL	00D 963 9005 642	R,METAL FILM 1.2K-J,1W	C060012265050S		
R127SR	00D 963 9005 642	R,METAL FILM 1.2K-J,1W	C060012265050S		
R132C	00D 960 9010 719	R,METAL FILM 47-J,1W	C060047065060S		
R132FL	00D 960 9010 719	R,METAL FILM 47-J,1W	C060047065060S		
R132FR	00D 960 9010 719	R,METAL FILM 47-J,1W	C060047065060S		
R132SL	00D 960 9010 719	R,METAL FILM 47-J,1W	C060047065060S		
R132SR	00D 960 9010 719	R,METAL FILM 47-J,1W	C060047065060S		
R147-149	00D 963 9005 642	R,METAL FILM 1.2K-J,1W	C060012265050S		
VR101C	00D 960 0221 109	VR,SEMI CARBON EVN-DJAA03B	C541102115000S		
VR101FL	00D 960 0221 109	VR,SEMI CARBON EVN-DJAA03B	C541102115000S		
VR101FR	00D 960 0221 109	VR,SEMI CARBON EVN-DJAA03B	C541102115000S		

Ref. No.	Part No.	Part Name	Remarks	Q'ty	New
VR101SL VR101SR	00D 960 0221 109 00D 960 0221 109	VR,SEMI CARBON EVN-DJAA03B VR,SEMI CARBON EVN-DJAA03B	C541102115000S C541102115000S		
CAPACITORS GROUP					
C101 C101C C101FL C101FR	00D 963 9005 804 00D 963 0234 506 00D 963 0234 506 00D 963 0234 506	C,ELECT 100UF-M/25V C,ELECT 47UF-M/50V (Pb Free) C,ELECT 47UF-M/50V (Pb Free) C,ELECT 47UF-M/50V (Pb Free)	D040101084060S D040470087070S D040470087070S D040470087070S		
C101SL C101SR C102 C102C C102FL	00D 963 0234 506 00D 963 0234 506 00D 963 0224 503 00D 963 0234 205 00D 960 9010 133	C,ELECT 47UF-M/50V (Pb Free) C,ELECT 47UF-M/50V (Pb Free) C,ELECT 22UF-M/50V C,ELECT 10UF-M/50V C,ELECT 220UF-M/35V	D040470087070S D040470087070S D040220087060S D040100087070S D040221085060S		
C102FR C102SL C102SR C103 C103C	00D 960 9010 133 00D 963 0234 205 00D 963 0234 205 00D 963 9006 557 00D 963 9003 084	C,ELECT 220UF-M/35V C,ELECT 10UF-M/50V C,ELECT 10UF-M/50V C,ELECT 220UF-M/6.3V C,CERAMIC 100PF-K/500V	D040221085060S D040100087070S D040100087070S D040221081060S D00410106D050S		
C103FL C103FR C103SL C103SR C104	00D 963 9003 084 00D 963 9003 084 00D 963 9003 084 00D 963 9003 084 00D 963 9006 557	C,CERAMIC 100PF-K/500V C,CERAMIC 100PF-K/500V C,CERAMIC 100PF-K/500V C,CERAMIC 100PF-K/500V C,ELECT 220UF-M/6.3V	D00410106D050S D00410106D050S D00410106D050S D00410106D050S D040221081060S		
C104C C104FL C104FR C104SL C104SR	00D 963 9003 084 00D 963 9003 084 00D 963 9003 084 00D 963 9003 084 00D 963 9003 084	C,CERAMIC 100PF-K/500V C,CERAMIC 100PF-K/500V C,CERAMIC 100PF-K/500V C,CERAMIC 100PF-K/500V C,CERAMIC 100PF-K/500V	D00410106D050S D00410106D050S D00410106D050S D00410106D050S D00410106D050S		
C105 C105C C105FL C105FR C105SL	00D 963 9006 557 nsp nsp nsp nsp	C,ELECT 220UF-M/6.3V C,CERAMIC 0.022UF-Z/50V C,CERAMIC 0.022UF-Z/50V C,CERAMIC 0.022UF-Z/50V C,CERAMIC 0.022UF-Z/50V	D040221081060S D011223597160S D011223597160S D011223597160S D011223597160S		
C105SR C106 C107 C107C C107FL	nsp 00D 963 0293 709 nsp 00D 963 9003 097 00D 963 9003 097	C,CERAMIC 0.022UF-Z/50V C,ELECT 100UF-M/10V C,CERAMIC 0.01UF-K/50V C,FILM 0.1UF-K/250V C,FILM 0.1UF-K/250V	D011223597160S D040101082070S D011103777160S D02010407H080S D02010407H080S		
C107FR C107SL C107SR C108 C108C	00D 963 9003 097 00D 963 9003 097 00D 963 9003 097 00D 963 0149 400 00D 963 9006 544	C,FILM 0.1UF-K/250V C,FILM 0.1UF-K/250V C,FILM 0.1UF-K/250V CAP.E.GENERIC 10000UF/63V(M) C,ELECT 22UF-M/25V	D02010407H080S D02010407H080S D02010407H080S N211210388110S D040220084050S		
C108FL C108FR C108SL C108SR C109	00D 963 9006 544 00D 963 9006 544 00D 963 9006 544 00D 963 9006 544 00D 963 0149 400	C,ELECT 22UF-M/25V C,ELECT 22UF-M/25V C,ELECT 22UF-M/25V C,ELECT 22UF-M/25V CAP.E.GENERIC 10000UF/63V(M)	D040220084050S D040220084050S D040220084050S D040220084050S N211210388110S		
C109C C109FL C109FR C109SL C109SR	00D 963 0234 205 00D 963 0234 205 00D 963 0234 205 00D 963 0234 205 00D 963 0234 205	C,ELECT 10UF-M/50V C,ELECT 10UF-M/50V C,ELECT 10UF-M/50V C,ELECT 10UF-M/50V C,ELECT 10UF-M/50V	D040100087070S D040100087070S D040100087070S D040100087070S D040100087070S		
C110 C110C	00D 963 9003 097 00D 963 0338 208	C,FILM 0.1UF-K/250V C,CERAMIC 470PF-K/500V	D02010407H080S D00447127D050S		

Ref. No.	Part No.	Part Name	Remarks	Q'ty	New
C110FL	00D 963 0338 208	C,CERAMIC 470PF-K/500V	D00447127D050S		
C110FR	00D 963 0338 208	C,CERAMIC 470PF-K/500V	D00447127D050S		
C110SL	00D 963 0338 208	C,CERAMIC 470PF-K/500V	D00447127D050S		
C110SR	00D 963 0338 208	C,CERAMIC 470PF-K/500V	D00447127D050S		
C111	00D 963 9003 097	C,FILM 0.1UF-K/250V	D02010407H080S		
C111C	00D 963 0367 101	C,CERAMIC 220PF-J/500V	D00422106D05CS		
C111FL	00D 963 0367 101	C,CERAMIC 220PF-J/500V	D00422106D05CS		
C111FR	00D 963 0367 101	C,CERAMIC 220PF-J/500V	D00422106D05CS		
C111SL	00D 963 0367 101	C,CERAMIC 220PF-J/500V	D00422106D05CS		
C111SR	00D 963 0367 101	C,CERAMIC 220PF-J/500V	D00422106D05CS		
C112	00D 963 9003 097	C,FILM 0.1UF-K/250V	D02010407H080S		
C112C	00D 963 9003 194	C,FILM 0.0022UF-J/100V	D02022206C060S		
C112FL	00D 963 9003 194	C,FILM 0.0022UF-J/100V	D02022206C060S		
C112FR	00D 963 9003 194	C,FILM 0.0022UF-J/100V	D02022206C060S		
C112SL	00D 963 9003 194	C,FILM 0.0022UF-J/100V	D02022206C060S		
C112SR	00D 963 9003 194	C,FILM 0.0022UF-J/100V	D02022206C060S		
C113C	00D 963 0293 709	C,ELECT 100UF-M/10V	D040101082070S		
C113FL	00D 960 9010 133	C,ELECT 220UF-M/35V	D040221085060S		
C113FR	00D 960 9010 133	C,ELECT 220UF-M/35V	D040221085060S		
C113SL	00D 963 0293 709	C,ELECT 100UF-M/10V	D040101082070S		
C113SR	00D 963 0293 709	C,ELECT 100UF-M/10V	D040101082070S		
C114	00D 963 9003 097	C,FILM 0.1UF-K/250V	D02010407H080S		
C114C	00D 963 0216 100	C,CERAMIC 33PF-J/500V	D00033006D050S		
C114FL	00D 963 0216 100	C,CERAMIC 33PF-J/500V	D00033006D050S		
C114FR	00D 963 0216 100	C,CERAMIC 33PF-J/500V	D00033006D050S		
C114SL	00D 963 0216 100	C,CERAMIC 33PF-J/500V	D00033006D050S		
C114SR	00D 963 0216 100	C,CERAMIC 33PF-J/500V	D00033006D050S		
C115	00D 963 9003 097	C,FILM 0.1UF-K/250V	D02010407H080S		
C115SW	00D 963 9006 544	C,ELECT 22UF-M/25V	D040220084050S		
C117-120	nsp	C,CERAMIC 0.1UF-K/50V	D011104577160S		
C141SW1	00D 963 0234 205	C,ELECT 10UF-M/50V	D040100087070S		
C142SW1	nsp	C,CERAMIC 100PF-J/50V	D010101167160S		
C161	00D 963 0234 205	C,ELECT 10UF-M/50V	D040100087070S		
C162,163	nsp	C,CERAMIC 0.01UF-K/50V	D011103777160S		
C164-167	nsp	C,CERAMIC 100PF-J/50V	D010101167160S		
C168-172	00D 963 0244 606	C,ELECT 0.1UF-M/50V (Pb Free)	D040R10087080S		
C177	nsp	C,CERAMIC 0.01UF-K/50V	D011103777160S		
C178,179	00D 960 9010 010	C,ELECT 4.7UF-M/50V	D0404R7087250S		
C180,181	nsp	C,CERAMIC 0.01UF-K/50V	D011103777160S		
C182	00D 963 0324 005	C,ELECT 100UF-M/100V	D04010108C240S		
C183	00D 963 0293 602	C,ELECT 1UF-M/50V (Pb Free)	D040010087150S		
C190	00D 960 9010 010	C,ELECT 4.7UF-M/50V	D0404R7087250S		
OTHERS PARTS GROUP					
BKT101	nsp	SHIELD PLATE GND	3070045526010S		
CN101	nsp	CN,WIRE 14P	L000111140010S		
CN103	nsp	CN,WIRE 120MM/7P	L000121070060S		
CN201	nsp	CN,WIRE 70MM/6P	L000700060110S		
CN511	nsp	CN,WIRE 60MM/9P	L000600090020S		
CN704	nsp	CN,WIRE 15P	L000600150030S		
CP103	nsp	CN.WAFER 3P	L102526700300S		
CP104	nsp	CN.WAFER 3CKT	L108353280360S		
CP106	nsp	CN.WAFER 5P	L101100040510S		

Ref. No.	Part No.	Part Name	Remarks	Q'ty	New
CP107	nsp	CN.WAFER 3P	L102526700300S		
CP108	nsp	CN.WAFER 17P	L101100041710S		
CP541	nsp	CN.WAFER 3P	L101220030000S		
GND101	nsp	TERMINAL EARTH	3790040886000S		
JACK222	00D 963 0146 005	TER,RCA 1PIN	G600107A0000YS		
L101C	00D 963 0049 005	COIL INDUCTOR 0.5UH	D330R50000000S		
L101FL	00D 963 0049 005	COIL INDUCTOR 0.5UH	D330R50000000S		
L101FR	00D 963 0049 005	COIL INDUCTOR 0.5UH	D330R50000000S		
L101SL	00D 963 0049 005	COIL INDUCTOR 0.5UH	D330R50000000S		
L101SR	00D 963 0049 005	COIL INDUCTOR 0.5UH	D330R50000000S		
RLY541	00D 963 0218 506	RELAY BC3-24 24V 2A	G680240202040S		
TP101-105	nsp	CN.WAFER 3P	L101530140310S		
JP108	00D 963 0223 009	R,THICK 0-J,1/16W	C20000006M160S		
JP350-352	00D 963 0223 009	R,THICK 0-J,1/16W	C20000006M160S		

FRONT P.W.B. UNIT ASS'Y

	Ref. No.	Part No.	Part Name	Remarks	Q'ty	New
SEMICONDUCTORS GROUP						
	IC301	00D 963 0074 504	IC BU2090F-E2	J044209000010S		
	IC302	00D 262 3758 009	LC87F6D64A-QFP-E	J127876160010S		
▲	IC303	00D 960 0195 808	IC ICP-N15	J120001500030S		
	IC305	00D 963 0024 004	IC NJM2068M	J121206800020S		
	Q301-303	00D 963 0120 704	TR KRA102S	J520010200210S		
	Q304	00D 963 0121 606	TR KRC107S	J522107S00210S		
	Q305	00D 963 0102 803	TR 2SA933S	J5000933S0050S		
	Q306	00D 963 0120 801	TR KRC102S	J522010200210S		
	Q307-309	00D 963 0120 704	TR KRA102S	J520010200210S		
	Q310,311	00D 963 0120 801	TR KRC102S	J522010200210S		
	Q312	00D 960 0133 103	TR KSA916Y	J5000916Y0050S		
	Q542-546	00D 963 0121 208	TR KRC107M	J6020107M0010S		
	D301,302	00D 963 0020 309	D,SWITCHING 1SS133T	K000013300520S		
	D303	00D 963 0355 401	D,SWITCHING KDS4148U	K005041480030S		
	D304	00D 963 0020 309	D,SWITCHING 1SS133T	K000013300520S		
	D305-311	00D 963 0355 401	D,SWITCHING KDS4148U	K005041480030S		
	D312	00D 963 0328 409	D,SWITCHING 1N4007	K000400700010S		
	D313-316	00D 963 0355 401	D,SWITCHING KDS4148U	K005041480030S		
	D542	00D 963 0020 309	D,SWITCHING 1SS133T	K000013300520S		
	D543-545	00D 963 0355 401	D,SWITCHING KDS4148U	K005041480030S		
	D546	00D 963 0020 309	D,SWITCHING 1SS133T	K000013300520S		
	ZD302-308	00D 960 0095 500	D,ZENER MTZJ5.1B	K06005R144520S		
	ZD309	00D 960 0095 801	D,ZENER MTZJ6.8B	K06006R844520S		
	ZD310,311	00D 963 0046 202	D,ZENER MTZJ18B	K06018R044520S		
	ZD312,313	00D 960 0095 500	D,ZENER MTZJ5.1B	K06005R144520S		
	LED302-309	00D 960 0197 204	LED PI5-RD/HL50RDRF4T	K500052015010S		
	LED310	00D 963 0366 108	LED BL-BEG204-L 5PI	K500052004010S		
	LED311	00D 963 0148 605	LED SML1216W 5PI	K500052600030S		
	FL301	00D 963 0257 305	DISPLAY,FLT HNA-16SM13T	K530161300020S		
RESISTORS GROUP						
	R372	00D 963 0215 907	R,METAL FILM 4.7-J,1W	C0604R7065050S		
	R378,379	00D 960 9009 270	R,METAL FILM 470-J,2W	C060047166520S		
	R501	00D 960 9003 700	R,METAL FILM 10-J,1/4W	C060010063050S		
	RP1-38	00D 963 0353 005	R,THICK 56K-J,1/16W	C20005636M160S		
	RG1-16	00D 963 0353 005	R,THICK 56K-J,1/16W	C20005636M160S		
CAPACITORS GROUP						
	C301,302	nsp	C,CERAMIC 100PF-J/50V	D010101167160S		
	C303	nsp	C,CERAMIC 0.022UF-K/25V	D011223777160S		
	C304	00D 963 9005 862	C,ELECT 47UF-M/16V	D040470083080S		
	C305	nsp	C,CERAMIC 100PF-J/50V	D010101167160S		
	C306	nsp	C,CERAMIC 0.047UF-Z/50V	D011473597160S		
	C307	00D 963 9005 862	C,ELECT 47UF-M/16V	D040470083080S		
	C308	nsp	C,CERAMIC 0.01UF-K/50V	D011103777160S		

Ref. No.	Part No.	Part Name	Remarks	Q'ty	New
C309,310	00D 963 0293 602	C,ELECT 1UF-M/50V (Pb Free)	D040010087150S		
C311	00D 963 0233 303	C,CERAMIC 0.01UF-M/16V	D005103773530S		
C312	00D 963 9005 862	C,ELECT 47UF-M/16V	D040470083080S		
C315	nsp	C,CERAMIC 150PF-J/50V	D010151167160S		
C316,317	nsp	C,CERAMIC 330PF-J/50V	D010331167160S		
C318	nsp	C,CERAMIC 100PF-J/50V	D010101167160S		
C319,320	nsp	C,CERAMIC 0.01UF-K/50V	D011103777160S		
C321,322	00D 963 0233 303	C,CERAMIC 0.01UF-M/16V	D005103773530S		
C323-325	00D 963 0293 602	C,ELECT 1UF-M/50V (Pb Free)	D040010087150S		
C326	00D 963 9005 862	C,ELECT 47UF-M/16V	D040470083080S		
C327,328	nsp	C,CERAMIC 0.1UF-K/50V	D011104577160S		
C329	nsp	C,FILM 0.1UF-J/100V	D02010406C060S		
C330	00D 963 0021 900	C,FILM 0.047UF-J/100V	D02047306C060S		
C331	00D 963 0234 205	C,ELECT 10UF-M/50V	D040100087070S		
C332	nsp	C,CERAMIC 150PF-J/50V	D010151167160S		
C333	00D 963 0293 602	C,ELECT 1UF-M/50V (Pb Free)	D040010087150S		
C334	00D 963 0021 900	C,FILM 0.047UF-J/100V	D02047306C060S		
C335	nsp	C,CERAMIC 0.1UF-K/50V	D011104577160S		
C336	nsp	C,CERAMIC 100PF-J/50V	D010101167160S		
C337	00D 963 0293 602	C,ELECT 1UF-M/50V (Pb Free)	D040010087150S		
C338	nsp	C,CERAMIC 0.01UF-K/50V	D011103777160S		
C339	nsp	C,CERAMIC 100PF-J/50V	D010101167160S		
C340	nsp	C,CERAMIC 1000PF-K/50V	D011102777160S		
C341,342	nsp	C,CERAMIC 100PF-J/50V	D010101167160S		
C343	00D 963 0020 202	C,CERAMIC 0.1UF-Z/50V	D005104597530S		
C344,345	00D 963 0233 206	C,CERAMIC 0.001UF-K/50V	D005102177530S		
C346-349	nsp	C,CERAMIC 0.01UF-K/50V	D011103777160S		
C350	00D 963 0021 900	C,FILM 0.047UF-J/100V	D02047306C060S		
C351	00D 963 0293 602	C,ELECT 1UF-M/50V (Pb Free)	D040010087150S		
C352	00D 963 0234 205	C,ELECT 10UF-M/50V	D040100087070S		
C353,354	00D 963 0293 602	C,ELECT 1UF-M/50V (Pb Free)	D040010087150S		
C355	nsp	C,ELECT 470UF-M/63V	D040471088010S		
C356	00D 963 9003 097	C,FILM 0.1UF-K/250V	D02010407H080S		
C357,358	nsp	C,CERAMIC 0.047UF-Z/50V	D011473597160S		
C541	nsp	C,CERAMIC 2200PF-K/50V	D011222777160S		
C541FL	00D 963 0024 703	C,FILM 0.01UF-J/100V	D02010306C060S		
C542	nsp	C,CERAMIC 2200PF-K/50V	D011222777160S		
C542FR	00D 963 0024 703	C,FILM 0.01UF-J/100V	D02010306C060S		
C543	nsp	C,CERAMIC 2200PF-K/50V	D011222777160S		
C543FL	00D 963 0024 703	C,FILM 0.01UF-J/100V	D02010306C060S		
C544	nsp	C,CERAMIC 2200PF-K/50V	D011222777160S		
C544FR	00D 963 0024 703	C,FILM 0.01UF-J/100V	D02010306C060S		
C545	nsp	C,CERAMIC 2200PF-K/50V	D011222777160S		
C545C	00D 963 0024 703	C,FILM 0.01UF-J/100V	D02010306C060S		
C546	nsp	C,CERAMIC 2200PF-K/50V	D011222777160S		
C546SL	00D 963 0024 703	C,FILM 0.01UF-J/100V	D02010306C060S		
C547	nsp	C,CERAMIC 2200PF-K/50V	D011222777160S		
C547SR	00D 963 0024 703	C,FILM 0.01UF-J/100V	D02010306C060S		
C548	nsp	C,CERAMIC 2200PF-K/50V	D011222777160S		
C548SBL	00D 963 0024 703	C,FILM 0.01UF-J/100V	D02010306C060S		
C549	nsp	C,CERAMIC 2200PF-K/50V	D011222777160S		
C549SBR	00D 963 0024 703	C,FILM 0.01UF-J/100V	D02010306C060S		
OTHERS PARTS GROUP					
BD301-307	nsp	COIL,BEAD MB-160808-0120H	D340160800060S		

Ref. No.	Part No.	Part Name	Remarks	Q'ty	New
CN102	nsp	CN,WIRE 270,170MM/4P	L000271040040S		
CN301	nsp	CN,WIRE 2P	L000401020050S		
CN302A	nsp	CN,WIRE 5P	L000450050010S		
CN303A	nsp	CN,WIRE 8P	L000450080010S		
CN304	nsp	CN,WIRE 3P	L000500030050S		
CN305	nsp	CN,WIRE 10P	L000700100030S		
CN541		CN,WIRE 3P	L000251030080S		
CP101	nsp	CN.WAFER 10P	L102526701000S		
CP103	nsp	CN.WAFER 7P	L101220070000S		
CP105	nsp	CN.WAFER 4P ANGLE	L102526800400S		
CP301B	nsp	CN.FPC 35P	L131103500010S		
CP302	nsp	CN.WAFER 3P ANGLE	L102526803010S		
CP304	nsp	CN.WAFER 3P	L101220030000S		
CP305		CN.WAFER 10P	L101220100010S		
CP306	nsp	CN.WAFER 03P	L101220030010S		
G301	nsp	RING,TER WIRE 120MM/1P	8410121010060S		
G302	nsp	RING,TER WIRE 120MM/1P	8410121010110S		
G304	nsp	RING,TER WIRE 120MM/1P	8410800020040S		
JACK301	00D 963 0367 802	JACK,D3.5 EARPHONE	G401PJ354H40YS		
JACK304	00D 963 0146 403	TER,RCA 3PIN	G606308HG110YS		
JACK501,502	00D 963 0146 607	TER,BOARD SCREW 8P	G614801A0200YS		
JACK503	00D 963 0158 608	TER,BOARD SCREW 2P	G611201A0200YS		
JK302	00D 963 0294 708	JACK,D6.5 PHONE	G402PJ612AG0YS		
L302	nsp	COIL INDUCTOR 10UH	D330100700520S		
L303	nsp	COIL INDUCTOR 100UH	D330101001020S		
RLY541	00D 963 0366 201	RELAY G5PA-28-MC 24V 5A	G680240502030S		
RLY543-546	00D 963 0366 201	RELAY G5PA-28-MC 24V 5A	G680240502030S		
RMC301	00D 963 0217 808	MODULE,REMOCON NJL34H380A	E940343800010S		
△ SW301	00D 963 0145 802	SW,PUSH SDDL-005-S(C-UL)	G000122006060S		
SW301A	00D 963 0095 305	SW,TACT SKHV10910D01	G180040500010S		
SW301C	00D 963 0095 305	SW,TACT SKHV10910D01	G180040500010S		
SW302A	00D 963 0095 305	SW,TACT SKHV10910D01	G180040500010S		
SW302B	00D 963 0095 305	SW,TACT SKHV10910D01	G180040500010S		
SW302C	00D 963 0095 305	SW,TACT SKHV10910D01	G180040500010S		
SW303A	00D 963 0095 305	SW,TACT SKHV10910D01	G180040500010S		
SW303B	00D 963 0095 305	SW,TACT SKHV10910D01	G180040500010S		
SW303C	00D 963 0095 305	SW,TACT SKHV10910D01	G180040500010S		
SW304A	00D 963 0095 305	SW,TACT SKHV10910D01	G180040500010S		
SW304B	00D 963 0095 305	SW,TACT SKHV10910D01	G180040500010S		
SW304C	00D 963 0095 305	SW,TACT SKHV10910D01	G180040500010S		
SW305A	00D 963 0095 305	SW,TACT SKHV10910D01	G180040500010S		
SW305B	00D 963 0095 305	SW,TACT SKHV10910D01	G180040500010S		
SW305C	00D 963 0095 305	SW,TACT SKHV10910D01	G180040500010S		
SW306A	00D 963 0095 305	SW,TACT SKHV10910D01	G180040500010S		
SW306B	00D 963 0095 305	SW,TACT SKHV10910D01	G180040500010S		
SW306C	00D 963 0095 305	SW,TACT SKHV10910D01	G180040500010S		
SW307A	00D 963 0095 305	SW,TACT SKHV10910D01	G180040500010S		

Ref. No.	Part No.	Part Name	Remarks	Q'ty	New
SW307B	00D 963 0095 305	SW,TACT SKHV10910D01	G180040500010S		
SW307C	00D 963 0095 305	SW,TACT SKHV10910D01	G180040500010S		
SW308A	00D 963 0095 305	SW,TACT SKHV10910D01	G180040500010S		
SW308B	00D 963 0095 305	SW,TACT SKHV10910D01	G180040500010S		
SW308C	00D 963 0095 305	SW,TACT SKHV10910D01	G180040500010S		
SW309A	00D 963 0095 305	SW,TACT SKHV10910D01	G180040500010S		
SW310	00D 963 0095 305	SW,TACT SKHV10910D01	G180040500010S		
VEC203	00D 963 0300 401	SW,ENCODER EC11B20C2	G121112020000S		
VEC301	00D 963 0095208	SW,ENCODER EC16B24SO	G121162400070S		
VEC303	00D 963 0095208	SW,ENCODER EC16B24SO	G121162400070S		
	nsp	HOLDER FLT	4320200026000S		

INPUT P.W.B. UNIT ASS'Y

Ref. No.	Part No.	Part Name	Remarks	Q'ty	New
SEMICONDUCTORS GROUP					
IC700	00D 963 0366 304	IC R2A15215FP		J084152150010S	
IC702	00D 963 0024 004	IC NJM2068M		J121206800020S	
IC705-718	00D 963 0024 004	IC NJM2068M		J121206800020S	
Q700,701	00D 960 0196 807	TR 2SK117Y		J5441170Y0050S	
Q702	00D 963 0120 704	TR KRA102S		J520010200210S	
Q703	00D 960 0285 006	TR KRC104S		J522104S00210S	
D700,701	00D 963 0355 401	D,SWITCHING KDS4148U		K005041480030S	
ZD700,701	00D 960 0222 603	D,ZENER MTZJ7.5A		K06007R544530S	
RESISTORS GROUP					
R706-709	00D 963 9005 639	R,METAL FILM 100-J,1W		C060010165060S	
R791VC	nsp	R,METAL FILM 120-J,1W		C060012165060S	
R791VE	nsp	R,METAL FILM 120-J,1W		C060012165060S	
CAPACITORS GROUP					
C700	00D 963 0234 205	C,ELECT 10UF-M/50V		D040100087070S	
C702SW	00D 960 9010 010	C,ELECT 4.7UF-M/50V		D0404R7087250S	
C703C	nsp	C,CERAMIC 0.047UF-Z/50V		D011473597160S	
C703SW	nsp	C,CERAMIC 0.047UF-Z/50V		D011473597160S	
C704,705	00D 963 9005 875	C,ELECT 47UF-M/25V		D040470084070S	
C706FL	00D 963 9005 875	C,ELECT 47UF-M/25V		D040470084070S	
C706FR	00D 963 9005 875	C,ELECT 47UF-M/25V		D040470084070S	
C707FL	00D 963 0234 205	C,ELECT 10UF-M/50V		D040100087070S	
C707FR	00D 963 0234 205	C,ELECT 10UF-M/50V		D040100087070S	
C707SW	00D 963 0234 205	C,ELECT 10UF-M/50V		D040100087070S	
C708FL	nsp	C,CERAMIC 33PF-J/50V		D010330167160S	
C708FR	nsp	C,CERAMIC 33PF-J/50V		D010330167160S	
C708SW	nsp	C,CERAMIC 47PF-J/50V		D010470167160S	
C709FL	nsp	C,CERAMIC 0.047UF-Z/50V		D011473597160S	
C709FR	nsp	C,CERAMIC 0.047UF-Z/50V		D011473597160S	
C709SW	nsp	C,CERAMIC 0.047UF-Z/50V		D011473597160S	
C710	00D 963 0223 009	R,THICK 0-J,1/16W		C20000006M160S	
C710FL	nsp	C,CERAMIC 100PF-J/50V		D010101167160S	
C710FR	nsp	C,CERAMIC 100PF-J/50V		D010101167160S	
C710SW	nsp	C,CERAMIC 100PF-J/50V		D010101167160S	
C711	00D 963 0223 009	R,THICK 0-J,1/16W		C20000006M160S	
C711FL	nsp	C,CERAMIC 0.047UF-Z/50V		D011473597160S	
C711FR	nsp	C,CERAMIC 0.047UF-Z/50V		D011473597160S	
C711SW	nsp	C,CERAMIC 0.047UF-Z/50V		D011473597160S	
C712	00D 963 0293 602	C,ELECT 1UF-M/50V (Pb Free)		D040010087150S	
C713-715	00D 963 0223 009	R,THICK 0-J,1/16W		C20000006M160S	
C716-727	00D 960 9009 814	C,CERAMIC 330PF-J/50V		D010331167160S	
C728-731	nsp	C,CERAMIC 20PF-J/50V		D010200167160S	
C732-739	00D 960 9009 814	C,CERAMIC 330PF-J/50V		D010331167160S	
C740-751	00D 963 0234 205	C,ELECT 10UF-M/50V		D040100087070S	
C751A	00D 963 0234 205	C,ELECT 10UF-M/50V		D040100087070S	
C751B	00D 963 0234 205	C,ELECT 10UF-M/50V		D040100087070S	
C751C	00D 963 0234 205	C,ELECT 10UF-M/50V		D040100087070S	
C751D	00D 963 0234 205	C,ELECT 10UF-M/50V		D040100087070S	

Ref. No.	Part No.	Part Name	Remarks	Q'ty	New
C751E	00D 963 0234 205	C,ELECT 10UF-M/50V	D040100087070S		
C751F	00D 963 0234 205	C,ELECT 10UF-M/50V	D040100087070S		
C751G	00D 963 0234 205	C,ELECT 10UF-M/50V	D040100087070S		
C751H	00D 963 0234 205	C,ELECT 10UF-M/50V	D040100087070S		
C751J	00D 963 0234 205	C,ELECT 10UF-M/50V	D040100087070S		
C751K	00D 963 0234 205	C,ELECT 10UF-M/50V	D040100087070S		
C751L	00D 963 0234 205	C,ELECT 10UF-M/50V	D040100087070S		
C751M	00D 963 0234 205	C,ELECT 10UF-M/50V	D040100087070S		
C751N	00D 963 0234 205	C,ELECT 10UF-M/50V	D040100087070S		
C751P	00D 963 0234 205	C,ELECT 10UF-M/50V	D040100087070S		
C751Q	00D 963 0234 205	C,ELECT 10UF-M/50V	D040100087070S		
C751R	00D 963 0234 205	C,ELECT 10UF-M/50V	D040100087070S		
C751S	00D 963 0234 205	C,ELECT 10UF-M/50V	D040100087070S		
C751T	00D 963 0234 205	C,ELECT 10UF-M/50V	D040100087070S		
C751U	00D 963 0234 205	C,ELECT 10UF-M/50V	D040100087070S		
C751V	00D 963 0234 205	C,ELECT 10UF-M/50V	D040100087070S		
C752	00D 963 0234 205	C,ELECT 10UF-M/50V	D040100087070S		
C752A	nsp	C,CERAMIC 0.047UF-Z/50V	D011473597160S		
C752B	nsp	C,CERAMIC 0.047UF-Z/50V	D011473597160S		
C752C	nsp	C,CERAMIC 0.047UF-Z/50V	D011473597160S		
C752D	nsp	C,CERAMIC 0.047UF-Z/50V	D011473597160S		
C752E	nsp	C,CERAMIC 0.047UF-Z/50V	D011473597160S		
C752F	nsp	C,CERAMIC 0.047UF-Z/50V	D011473597160S		
C752G	nsp	C,CERAMIC 0.047UF-Z/50V	D011473597160S		
C752H	nsp	C,CERAMIC 0.047UF-Z/50V	D011473597160S		
C752J	nsp	C,CERAMIC 0.047UF-Z/50V	D011473597160S		
C752K	nsp	C,CERAMIC 0.047UF-Z/50V	D011473597160S		
C752L	nsp	C,CERAMIC 0.047UF-Z/50V	D011473597160S		
C752M	nsp	C,CERAMIC 0.047UF-Z/50V	D011473597160S		
C752N	nsp	C,CERAMIC 0.047UF-Z/50V	D011473597160S		
C752P	nsp	C,CERAMIC 0.047UF-Z/50V	D011473597160S		
C752Q	nsp	C,CERAMIC 0.047UF-Z/50V	D011473597160S		
C752R	nsp	C,CERAMIC 0.047UF-Z/50V	D011473597160S		
C752S	nsp	C,CERAMIC 0.047UF-Z/50V	D011473597160S		
C752T	nsp	C,CERAMIC 0.047UF-Z/50V	D011473597160S		
C752U	nsp	C,CERAMIC 0.047UF-Z/50V	D011473597160S		
C752V	nsp	C,CERAMIC 0.047UF-Z/50V	D011473597160S		
C752W	nsp	C,CERAMIC 0.1UF-Z/50V	D011104597160S		
C752X	nsp	C,CERAMIC 0.1UF-Z/50V	D011104597160S		
C753-771	00D 963 0234 205	C,ELECT 10UF-M/50V	D040100087070S		
C772,773	00D 963 0293 806	C,ELECT 100UF-M/10V (Pb Free)	D040101082090S		
C774	nsp	C,FILM 0.15UF-K/63V	D020154078060S		
C775	00D 963 0021 900	C,FILM 0.047UF-J/100V	D02047306C060S		
C776	00D 960 9008 640	C,FILM 0.022UF-J/100V	D02022306C060S		
C777	00D 963 0234 205	C,ELECT 10UF-M/50V	D040100087070S		
C778,779	nsp	C,CERAMIC 100PF-J/50V	D010101167160S		
C780	00D 963 0234 205	C,ELECT 10UF-M/50V	D040100087070S		
C781	00D 960 9008 640	C,FILM 0.022UF-J/100V	D02022306C060S		
C782	00D 963 0021 900	C,FILM 0.047UF-J/100V	D02047306C060S		
C783	nsp	C,FILM 0.15UF-K/63V	D020154078060S		
C784-790	00D 963 0293 806	C,ELECT 100UF-M/10V (Pb Free)	D040101082090S		
C791-793	00D 963 0234 205	C,ELECT 10UF-M/50V	D040100087070S		
C794	00D 963 0293 806	C,ELECT 100UF-M/10V (Pb Free)	D040101082090S		
C796-799	00D 963 0234 205	C,ELECT 10UF-M/50V	D040100087070S		
C800,801	00D 960 9010 832	C,ELECT 10UF-M/16V,	D040100083050S		

Ref. No.	Part No.	Part Name	Remarks	Q'ty	New
OTHERS PARTS GROUP					
CLAMP501	nsp	CLAMP WIRE(SOLDER)		4330000120000S	
CN306	nsp	CN,WIRE 480MM/3P		L000481030060S	
CN514	nsp	CN,WIRE 13P		L000181130010S	
CN702	nsp	CN.HOUSING 15P		L120912150010S	
CN703	nsp	CN.WAFER 8P		L101100030810S	
CN704	nsp	CN.WAFER 19P		L101100031910S	
CN706	nsp	CN,WIRE 8P		L000121080010S	
CP704	nsp	CN.WAFER 15P		L101220150000S	
CP705	nsp	CN.WAFER 3P		L101220030000S	
JACK701	00D 963 0132 103	TER,RCA 4PIN		G602405B0400YS	
JACK702	00D 963 0387 505	TER,RCA 4PIN		G602405B5500YS	
JACK703	00D 963 0132 103	TER,RCA 4PIN		G602405B0400YS	
JACK704,705	00D 963 0132 307	TER,RCA 6PIN		G603603B05000S	

POWER P.W.B. UNIT ASS'Y

	Ref. No.	Part No.	Part Name	Remarks	Q'ty	New
SEMICONDUCTORS GROUP						
▲	IC501	00D 963 0057 806	IC KIA78R05PI	J126780500370S		
	IC502	00D 960 0195 808	IC ICP-N15	J120001500030S		
	IC511	00D 963 0147 606	IC KIA78R09API	J126780900120S		
	IC512	00D 960 0159 501	IC KIA7805API	J126780500110S		
	IC513	00D 963 0327 507	IC KIA7905PI	J126790500070S		
	IC515	00D 960 0174 900	IC KIA7815API	J126781500000S		
	IC516	00D 963 0021 502	IC KIA7915PI	J126791500030S		
	Q501	00D 960 0196 409	TR 2SC1740SR	J5021740S0010S		
	Q502	00D 963 0121 208	TR KRC107M	J6020107M0010S		
	Q503	00D 960 0196 409	TR 2SC1740SR	J5021740S0010S		
	D501-503	00D 276 0401 905	D,SWITCHING 1SS133T	K000013300520S		
	D504-507	00D 963 0328 409	D,SWITCHING 1N4007	K000400700010S		
	D508,509	00D 276 0401 905	D,SWITCHING 1SS133T	K000013300520S		
	D511,512	00D 276 0401 905	D,SWITCHING 1SS133T	K000013300520S		
	D513-520	00D 963 0328 409	D,SWITCHING 1N4007	K000400700010S		
	D521,522	00D 276 0401 905	D,SWITCHING 1SS133T	K000013300520S		
	D523-526	00D 963 0328 409	D,SWITCHING 1N4007	K000400700010S		
	ZD501	00D 960 0095 500	D,ZENER MTZJ5.1B	K06005R144520S		
	ZD502	00D 963 0219 903	D,ZENER MTZJ16B	K06016R044520S		
RESISTORS GROUP						
	R507	00D 241 2376 964	R,METAL FILM 47-J,1/4W	C060047063050S		
	R508,509	00D 963 0216 003	R,METAL FILM 0.22-J,1W	C060R22065050S		
	R516-519	00D 963 0216 003	R,METAL FILM 0.22-J,1W	C060R22065050S		
CAPACITORS GROUP						
	C501	00D 963 0234 205	C,ELECT 10UF-M/50V	D040100087070S		
	C502	00D 963 0217 002	C,ELECT 3300UF-M/16V	D040332083010S		
	C503	00D 963 0293 602	C,ELECT 1UF-M/50V (Pb Free)	D040010087150S		
	C504	00D 963 0323 802	C,CERAMIC AC(SAFETY) 0.0047UF 250VAC	D00847208H010S		
	C506	00D 963 0293 602	C,ELECT 1UF-M/50V (Pb Free)	D040010087150S		
	C514-516	00D 963 0293 602	C,ELECT 1UF-M/50V (Pb Free)	D040010087150S		
	C517	00D 963 0234 205	C,ELECT 10UF-M/50V	D040100087070S		
	C518	00D 963 0217 002	C,ELECT 3300UF-M/16V	D040332083010S		
	C519	00D 963 0324 704	C,ELECT 4700UF-M/16V	D040472083200S		
	C520	00D 963 0021 104	C,ELECT 6800UF-M/16V	D040682083000S		
	C521-523	00D 963 0021 900	C,FILM 0.047UF-J/100V	D02047306C060S		
	C526,527	00D 960 0186 202	C,ELECT 220UF-M/35V	D040221085050S		
	C528	00D 963 0324 908	C,ELECT 4700UF-M/35V	D040472085020S		
	C529	00D 963 0224 707	C,ELECT 2200UF-M/35V	D040222085020S		
	C530-532	00D 963 0021 900	C,FILM 0.047UF-J/100V	D02047306C060S		
OTHERS PARTS GROUP						
	BKT501,502	nsp	SHIELD PLATE GND	3070045526010S		
	CLAMP102-105	nsp	CLAMP WIRE(SOLDER)	4330000120000S		

Ref. No.	Part No.	Part Name	Remarks	Q'ty	New
	CN505	nsp	CN.WAFER 7P	L101100030710S	
	CN506	nsp	CN.WAFER 12P	L101100031210S	
	CP501	nsp	CN.WAFER 2CKT,YEL	L108353280290S	
	CP503	nsp	CN.WAFER 2CKT,RED	L108353280280S	
	CP504	nsp	CN.WAFER ST2P	L108202000220S	
	CP505	nsp	CN.WAFER 7P	L101100040710S	
	CP506	nsp	CN.WAFER 12P	L101100041210S	
	CP511	nsp	CN.WAFER 9P	L101220090000S	
	CP512	nsp	CN.WAFER 4P ANGLE	L102526800400S	
	CP513	nsp	CN.WAFER 3P ANGLE	L102526803010S	
	CP514		CN.WAFER 13P	L101220130000S	
⚠	F501	00D 963 0237 600	FUSE T2.5A /250V	N751222501110S	
	F501A	nsp	HOLDER,FUSE CLIP	G645000050010S	
	F501B	nsp	HOLDER,FUSE CLIP	G645000050010S	
⚠	F503	00D 963 0104 704	FUSE T3.15A /250V	N751223151110S	
	F503A	nsp	HOLDER,FUSE CLIP	G645000050010S	
	F503B	nsp	HOLDER,FUSE CLIP	G645000050010S	
	GND501	nsp	TERMINAL EARTH	3790040886000S	
	RLY501	00D 963 0218 205	RELAY HL3-1A-9SH DC9V 1A	G680090102020S	
⚠	SUB501	00D 963 0382 801	SUB TRANS	8200280150410S	
		nsp	HEAT SINK	2120043538050S	
		nsp	SCREW,TAP TITE +2S 3*8 B-TYPE ZNW/BH	B020030081B10S	
		00D 963 0328 409	D,SWITCHING 1N4007	K000400700010S	
		nsp	FUSE LABEL T4AL 250V	5507000001090S	
⚠		00D 960 0143 203	SOCKET,POWER RECEP	G435040110000S	

2CH-AMP P.W.B. UNIT ASS'Y

Ref. No.	Part No.	Part Name	Remarks	Q'ty	New
SEMICONDUCTORS GROUP					
IC401D	00D 960 0159 501	IC KIA7805API	J126780500110S		
IC401H	00D 963 0388 805	CN,WIRE 110MM/3P	L000111030040S		
IC402D	00D 963 0226 608	IC KIA78R33PI	J12678R330010S		
IC402X	00D 963 0366 603	IC KIA1117PI50	J126111750050S		
IC403D	00D 963 0366 706	IC KIA1117PI00	J126111700050S		
Q401SBL	00D 963 0044 204	TR 2SD2390-Y	J5032390Y0000S		
Q401SBR	00D 963 0044 204	TR 2SD2390-Y	J5032390Y0000S		
Q402D	00D 960 0097 304	TR KRC102M	J6020102M0010S		
Q402SBL	00D 963 0044 107	TR 2SB1560-Y	J5011560Y0000S		
Q402SBR	00D 963 0044 107	TR 2SB1560-Y	J5011560Y0000S		
Q403SBL	00D 963 0280 107	TR 2SC3964	J502396400000S		
Q403SBR	00D 963 0280 107	TR 2SC3964	J502396400000S		
Q404SBL	00D 960 0196 506	TR KSC1845F	J5021845F0000S		
Q404SBR	00D 960 0196 506	TR KSC1845F	J5021845F0000S		
Q405SBL	00D 273 0459 903	TR KTC2874B	J502287400010S		
Q405SBR	00D 273 0459 903	TR KTC2874B	J502287400010S		
Q406SBL	00D 960 0196 205	TR KSA992F	J5000992F0050S		
Q406SBR	00D 960 0196 205	TR KSA992F	J5000992F0050S		
Q407SBL	00D 960 0196 205	TR KSA992F	J5000992F0050S		
Q407SBR	00D 960 0196 205	TR KSA992F	J5000992F0050S		
Q408SBL	00D 960 0196 506	TR KSC1845F	J5021845F0000S		
Q408SBR	00D 960 0196 506	TR KSC1845F	J5021845F0000S		
Q409D	00D 960 0097 304	TR KRC102M	J6020102M0010S		
D401H	00D 963 0328 409	D,SWITCHING 1N4007	K000400700010S		
D401SBL	00D 963 0341 004	D,SWITCHING KDS4148U	K005041480030S		
D401SBR	00D 963 0341 004	D,SWITCHING KDS4148U	K005041480030S		
D401X	00D 963 0328 409	D,SWITCHING 1N4007	K000400700010S		
D402	00D 276 0401 905	D,SWITCHING 1SS133T	K000013300520S		
D402H	00D 963 0328 409	D,SWITCHING 1N4007	K000400700010S		
D402SBL	00D 963 0341 004	D,SWITCHING KDS4148U	K005041480030S		
D402SBR	00D 963 0341 004	D,SWITCHING KDS4148U	K005041480030S		
D402X	00D 963 0328 409	D,SWITCHING 1N4007	K000400700010S		
D403	00D 276 0401 905	D,SWITCHING 1SS133T	K000013300520S		
ZD401D	00D 960 0095 607	D,ZENER MTZJ5.6B	K06005R644520S		
ZD401SBL	00D 963 0367 008	D,ZENER 0.2W 3.3V UDZ	K06603R34P400S		
ZD401SBR	00D 963 0367 008	D,ZENER 0.2W 3.3V UDZ	K06603R34P400S		
ZD402SBL	00D 963 0367 008	D,ZENER 0.2W 3.0V UDZ	K06603R04P400S		
ZD402SBR	00D 963 0367 008	D,ZENER 0.2W 3.0V UDZ	K06603R04P400S		
RESISTORS GROUP					
R401D	00D 963 9006 269	R,FIXED 1WJ-0.22	N113135622820S		
R401H	00D 963 9006 269	R,FIXED 1WJ-0.22	N113135622820S		
R401X	00D 963 9006 269	R,FIXED 1WJ-0.22	N113135622820S		
R402D	00D 963 9006 269	R,FIXED 1WJ-0.22	N113135622820S		
R402H	00D 963 9006 269	R,FIXED 1WJ-0.22	N113135622820S		
R402X	00D 963 9006 269	R,FIXED 1WJ-0.22	N113135622820S		
R410SBL	00D 963 9005 642	R,METAL FILM 1.2K-J,1W	C060012265050S		
R410SBR	00D 963 9005 642	R,METAL FILM 1.2K-J,1W	C060012265050S		
R411SBL	00D 960 9010 719	R,METAL FILM 47-J,1W	C060047065060S		
R411SBR	00D 960 9010 719	R,METAL FILM 47-J,1W	C060047065060S		

Ref. No.	Part No.	Part Name	Remarks	Q'ty	New
R414SBL	00D 963 9006 285	R,FIXED 1WJ-5.6K	N113135656220S		
R414SBR	00D 963 9006 285	R,FIXED 1WJ-5.6K	N113135656220S		
R415SBL	00D 963 9006 285	R,FIXED 1WJ-5.6K	N113135656220S		
R415SBR	00D 963 9006 285	R,FIXED 1WJ-5.6K	N113135656220S		
R419SBL	00D 963 0215 907	R,METAL FILM 4.7-J,1W	C0604R7065050S		
R419SBR	00D 963 0215 907	R,METAL FILM 4.7-J,1W	C0604R7065050S		
R420SBL	00D 963 0215 907	R,METAL FILM 4.7-J,1W	C0604R7065050S		
R420SBR	00D 963 0215 907	R,METAL FILM 4.7-J,1W	C0604R7065050S		
R421SBL	00D 963 0345 903	R,FIXED 2WJ-0.47	N113136647820S		
R421SBR	00D 963 0345 903	R,FIXED 2WJ-0.47	N113136647820S		
R422SBL	00D 963 0345 903	R,FIXED 2WJ-0.47	N113136647820S		
R422SBR	00D 963 0345 903	R,FIXED 2WJ-0.47	N113136647820S		
R423SBL	00D 963 0345 903	R,FIXED 2WJ-0.47	N113136647820S		
R423SBR	00D 963 0345 903	R,FIXED 2WJ-0.47	N113136647820S		
R424SBL	00D 963 0345 903	R,FIXED 2WJ-0.47	N113136647820S		
R424SBR	00D 963 0345 903	R,FIXED 2WJ-0.47	N113136647820S		
R429SBL	00D 963 9006 256	R,FIXED 1WJ-10	N113135610020S		
R429SBR	00D 963 9006 256	R,FIXED 1WJ-10	N113135610020S		
R430SBL	00D 963 9006 256	R,FIXED 1WJ-10	N113135610020S		
R430SBR	00D 963 9006 256	R,FIXED 1WJ-10	N113135610020S		
VR401,402	00D 963 0366 407	VR,SEMI CARBON EVN-DCAA03B 1KB	C541102315000S		
CAPACITORS GROUP					
C401D	00D 963 0021 900	C,FILM 0.047UF-J/100V	D02047306C060S		
C401H	00D 963 0021 900	C,FILM 0.047UF-J/100V	D02047306C060S		
C401SBL	00D 963 9006 544	C,ELECT 22UF-M/25V	D040220084050S		
C401SBR	00D 963 9006 544	C,ELECT 22UF-M/25V	D040220084050S		
C401X	nsp	C,CERAMIC 0.1UF-K/50V	D011104577160S		
C402D	00D 963 0021 900	C,FILM 0.047UF-J/100V	D02047306C060S		
C402H	00D 963 0021 900	C,FILM 0.047UF-J/100V	D02047306C060S		
C402SBL	00D 963 0234 205	C,ELECT 10UF-M/50V	D040100087070S		
C402SBR	00D 963 0234 205	C,ELECT 10UF-M/50V	D040100087070S		
C402X	00D 963 9003 097	C,FILM 0.1UF-K/250V	D02010407H080S		
C403D	00D 963 0021 900	C,FILM 0.047UF-J/100V	D02047306C060S		
C403H	00D 963 0021 900	C,FILM 0.047UF-J/100V	D02047306C060S		
C403SBL	00D 963 0367 101	C,CERAMIC 220PF-J/500V	D00422106D05CS		
C403SBR	00D 963 0367 101	C,CERAMIC 220PF-J/500V	D00422106D05CS		
C404D	00D 960 0133 404	C,ELECT SHL 10000UF 16V	D040103083020S		
C404H	00D 963 0217 002	C,ELECT 3300UF-M/16V	D040332083010S		
C404SBL	00D 963 0338 208	C,CERAMIC 470PF-K/500V	D00447127D050S		
C404SBR	00D 963 0338 208	C,CERAMIC 470PF-K/500V	D00447127D050S		
C404X	00D 963 0276 409	C,ELECT 100UF-M/16V	D040101083090S		
C405D	00D 963 0338 402	C,ELECT 330UF-M/6.3V	D040331081050S		
C405SBL	00D 963 0216 100	C,CERAMIC 33PF-J/500V	D00033006D050S		
C405SBR	00D 963 0216 100	C,CERAMIC 33PF-J/500V	D00033006D050S		
C406D	nsp	C,CERAMIC 0.1UF-K/50V	D011104577160S		
C406SBL	00D 963 0293 709	C,ELECT 100UF-M/10V	D040101082070S		
C406SBR	00D 963 0293 709	C,ELECT 100UF-M/10V	D040101082070S		
C406X	nsp	C,CERAMIC 1000PF-K/50V	D011102777160S		
C407D	nsp	C,CERAMIC 1000PF-K/50V	D011102777160S		
C407SBL	00D 963 9003 194	C,FILM 0.0022UF-J/100V	D02022206C060S		
C407SBR	00D 963 9003 194	C,FILM 0.0022UF-J/100V	D02022206C060S		
C407X	00D 963 0293 709	C,ELECT 100UF-M/10V	D040101082070S		
C408D	00D 963 0338 402	C,ELECT 330UF-M/6.3V	D040331081050S		

Ref. No.	Part No.	Part Name	Remarks	Q'ty	New
C408SBL	00D 963 0234 506	C,ELECT 47UF-M/50V (Pb Free)	D040470087070S		
C408SBR	00D 963 0234 506	C,ELECT 47UF-M/50V (Pb Free)	D040470087070S		
C409D	nsp	C,CERAMIC 0.1UF-K/50V	D011104577160S		
C409SBL	00D 963 9003 084	C,CERAMIC 100PF-K/500V	D00410106D050S		
C409SBR	00D 963 9003 084	C,CERAMIC 100PF-K/500V	D00410106D050S		
C410D	00D 963 0338 402	C,ELECT 330UF-M/6.3V	D040331081050S		
C410SBL	00D 963 0234 205	C,ELECT 10UF-M/50V	D040100087070S		
C410SBR	00D 963 0234 205	C,ELECT 10UF-M/50V	D040100087070S		
C411D	nsp	C,CERAMIC 0.1UF-K/50V	D011104577160S		
C411SBL	00D 963 9003 084	C,CERAMIC 100PF-K/500V	D00410106D050S		
C411SBR	00D 963 9003 084	C,CERAMIC 100PF-K/500V	D00410106D050S		
C412D	nsp	C,CERAMIC 0.1UF-K/50V	D011104577160S		
C412SBL	nsp	C,CERAMIC 0.022UF-K/25V	D011223777160S		
C412SBR	nsp	C,CERAMIC 0.022UF-K/25V	D011223777160S		
C413D	00D 963 0024 907	C,ELECT 1000UF-M/6.3V	D040102081060S		
C413SBL	00D 963 9003 097	C,FILM 0.1UF-K/250V	D02010407H080S		
C413SBR	00D 963 9003 097	C,FILM 0.1UF-K/250V	D02010407H080S		
C443	nsp	C,CERAMIC 1000PF-K/50V	D011102777160S		
OTHERS PARTS GROUP					
CLAMP401	nsp	CLAMP WIRE(SOLDER)	4330000120000S		
CN203	nsp	CN,WIRE 160MM/3P	L000161030060S		
CN401A	nsp	CN,WIRE 5P	L000191050030S		
CN405	nsp	CN,WIRE 5P	L000321050020S		
CN705	nsp	CN,WIRE 150MM/3P	L000151030010S		
CN904	nsp	CN,WIRE 6P	L000141060030S		
CP102	nsp	CN.WAFER 3P	L102526700300S		
CP201	nsp	CN.WAFER 10P	L101220100000S		
CP402	nsp	CN.WAFER 3P	L102526700300S		
L401SBL	nsp	COIL INDUCTOR 0.5UH	D330R50000000S		
L401SBR	nsp	COIL INDUCTOR 0.5UH	D330R50000000S		
TP401,402	nsp	CN.WAFER 3P ANGLE	L101530150310S		
	00D 963 0328 409	D,SWITCHING 1N4007	K000400700010S		

CPU P.W.B. UNIT ASS'Y

Ref. No.	Part No.	Part Name	Remarks	Q'ty	New
SEMICONDUCTORS GROUP					
IC712-715	00D 963 0024 004	IC NJM2068M		J121206800020S	
IC804	963243000020D	IC,CPU MICRO PROCESS	M30626FHPFP	89521508000154	
IC805	00D 963 0326 906	IC LC72722PM-TLM-E		J124727220010S	
IC806	00D 960 0100 301	IC KIA7812API		J126781200040S	
IC813	00D 963 0367 204	IC SN74HC151PWR		J040741510070S	
IC817	00D 963 0244 907	IC SN74LV14APWR		J040741400180S	
IC818	00D 963 0367 307	IC SN74AHCU04PWR		J040740400290S	
IC824	00D 963 0043 807	IC BA4510F-E2/SOP8		J121451000010S	
IC827	00D 963 0043 807	IC BA4510F-E2/SOP8		J121451000010S	
IC830	00D 262 2813 903	SN74AHCT08PW-EL2 +C		J040740800190S	
Q704C	00D 963 0044 301	TR KTC2875B(MB)	<div style="border: 1px solid black; border-radius: 10px; padding: 5px; width: fit-content;"> ファームウェアをアップデート するときは、SDIで最終バージョン を確認して下さい。 サービス基板はアップデートし て使用下さい。 When update Firmware, please confirm a last version in SDI. Use the service board after updating it. </div>	J5222875B0010S	
Q704FL	00D 963 0044 301	TR KTC2875B(MB)		J5222875B0010S	
Q704FR	00D 963 0044 301	TR KTC2875B(MB)		J5222875B0010S	
Q704SBL	00D 963 0044 301	TR KTC2875B(MB)		J5222875B0010S	
Q704SBR	00D 963 0044 301	TR KTC2875B(MB)		J5222875B0010S	
Q704SL	00D 963 0044 301	TR KTC2875B(MB)		J5222875B0010S	
Q704SR	00D 963 0044 301	TR KTC2875B(MB)		J5222875B0010S	
Q704SW	00D 963 0044 301	TR KTC2875B(MB)		J5222875B0010S	
Q801	00D 963 0120 704	TR KRA102S		J520010200210S	
Q802-805	00D 963 0044 301	TR KTC2875B(MB)		J5222875B0010S	
Q806	00D 963 0121 509	TR KTC3875S		J522038750210S	
Q807	00D 960 0285 006	TR KRC104S		J522104S00210S	
Q808	00D 963 0148 508	TR KTA1504S		J520015040150S	
Q809	00D 963 0120 801	TR KRC102S		J522010200210S	
Q810D	00D 963 0245 100	D,SWITCHING KDS226ST1(C3)		K005022600020S	
Q811D	00D 963 0245 100	D,SWITCHING KDS226ST1(C3)		K005022600020S	
Q812D	00D 963 0120 801	TR KRC102S		J522010200210S	
Q813D	00D 963 0120 704	TR KRA102S(PB)		J520010200210S	
D801-804	00D 963 0355 401	D,SWITCHING KDS4148U		K005041480030S	
D805	00D 963 0328 409	D,SWITCHING 1N4007		K000400700010S	
D806,807	00D 963 0355 401	D,SWITCHING KDS4148U		K005041480030S	
D807D	00D 963 0355 401	D,SWITCHING KDS4148U		K005041480030S	
D808D	00D 963 0341 305	D,ESD IMSA-6802-01A		K067680200010S	
D809D	00D 963 0355 401	D,SWITCHING KDS4148U		K005041480030S	
D810D	00D 963 0341 305	D,ESD IMSA-6802-01A		K067680200010S	
D811D	00D 963 0341 305	D,ESD IMSA-6802-01A		K067680200010S	
ZD801	00D 963 0047 502	D,ZENER MTZJ3.3B		K06003R344520S	
RESISTORS GROUP					
R857	00D 960 9003 807	R,METAL FILM 100-J,1/4W		C060010163050S	
CAPACITORS GROUP					
C751C	00D 963 0234 205	C,ELECT 10UF-M/50V		D040100087070S	
C751FL	00D 963 0234 205	C,ELECT 10UF-M/50V		D040100087070S	
C751FR	00D 963 0234 205	C,ELECT 10UF-M/50V		D040100087070S	
C751SBL	00D 963 0234 205	C,ELECT 10UF-M/50V		D040100087070S	
C751SBR	00D 963 0234 205	C,ELECT 10UF-M/50V		D040100087070S	
C751SL	00D 963 0234 205	C,ELECT 10UF-M/50V		D040100087070S	
C751SR	00D 963 0234 205	C,ELECT 10UF-M/50V		D040100087070S	

Ref. No.	Part No.	Part Name	Remarks	Q'ty	New
C751SW	00D 963 0234 205	C,ELECT 10UF-M/50V	D040100087070S		
C752C	00D 963 0350 503	C,CERAMIC 390PF-J/50V	D010391167160S		
C752FL	00D 963 0223 708	C,CERAMIC 270PF-J/50V	D010271167160S		
C752FR	00D 963 0223 708	C,CERAMIC 270PF-J/50V	D010271167160S		
C752SBL	00D 960 9009 814	C,CERAMIC 330PF-J/50V	D010331167160S		
C752SBR	00D 960 9009 814	C,CERAMIC 330PF-J/50V	D010331167160S		
C752SL	00D 960 9009 814	C,CERAMIC 330PF-J/50V	D010331167160S		
C752SR	00D 960 9009 814	C,CERAMIC 330PF-J/50V	D010331167160S		
C752SW	00D 963 0350 503	C,CERAMIC 390PF-J/50V	D010391167160S		
C753C	00D 963 0224 008	C,CERAMIC 470PF-J/50V	D010471167160S		
C753FL	00D 963 0223 902	C,CERAMIC 39PF-J/50V	D010390167160S		
C753FR	00D 963 0223 902	C,CERAMIC 39PF-J/50V	D010390167160S		
C753SBL	00D 963 0223 708	C,CERAMIC 270PF-J/50V	D010271167160S		
C753SBR	00D 963 0223 708	C,CERAMIC 270PF-J/50V	D010271167160S		
C753SL	00D 963 0223 708	C,CERAMIC 270PF-J/50V	D010271167160S		
C753SR	00D 963 0223 708	C,CERAMIC 270PF-J/50V	D010271167160S		
C753SW	00D 963 0224 008	C,CERAMIC 470PF-J/50V	D010471167160S		
C755C	nsp	C,CERAMIC 0.1UF-Z/50V	D011104597160S		
C755FL	nsp	C,CERAMIC 0.1UF-Z/50V	D011104597160S		
C755FR	nsp	C,CERAMIC 0.1UF-Z/50V	D011104597160S		
C755SBL	nsp	C,CERAMIC 0.1UF-Z/50V	D011104597160S		
C755SBR	nsp	C,CERAMIC 0.1UF-Z/50V	D011104597160S		
C755SL	nsp	C,CERAMIC 0.1UF-Z/50V	D011104597160S		
C755SR	nsp	C,CERAMIC 0.1UF-Z/50V	D011104597160S		
C755SW	nsp	C,CERAMIC 0.1UF-Z/50V	D011104597160S		
C756C	00D 963 9003 194	C,FILM 0.0022UF-J/100V	D02022206C060S		
C756FL	00D 963 9003 194	C,FILM 0.0022UF-J/100V	D02022206C060S		
C756FR	00D 963 9003 194	C,FILM 0.0022UF-J/100V	D02022206C060S		
C756SBL	00D 963 9003 194	C,FILM 0.0022UF-J/100V	D02022206C060S		
C756SBR	00D 963 9003 194	C,FILM 0.0022UF-J/100V	D02022206C060S		
C756SL	00D 963 9003 194	C,FILM 0.0022UF-J/100V	D02022206C060S		
C756SR	00D 963 9003 194	C,FILM 0.0022UF-J/100V	D02022206C060S		
C756SW	00D 963 9003 194	C,FILM 0.0022UF-J/100V	D02022206C060S		
C757C	nsp	C,CERAMIC 10UF-Z/10V	D011106592200S		
C757FL	nsp	C,CERAMIC 10UF-Z/10V	D011106592200S		
C757FR	nsp	C,CERAMIC 10UF-Z/10V	D011106592200S		
C757SBL	nsp	C,CERAMIC 10UF-Z/10V	D011106592200S		
C757SBR	nsp	C,CERAMIC 10UF-Z/10V	D011106592200S		
C757SL	nsp	C,CERAMIC 10UF-Z/10V	D011106592200S		
C757SR	nsp	C,CERAMIC 10UF-Z/10V	D011106592200S		
C757SW	nsp	C,CERAMIC 10UF-Z/10V	D011106592200S		
C803	nsp	C,CERAMIC 100PF-J/50V	D010101167160S		
C804,805	nsp	C,CERAMIC 0.1UF-Z/50V	D011104597160S		
C806	nsp	C,CERAMIC 0.01UF-K/50V	D011103777160S		
C807,808	nsp	C,CERAMIC 0.022UF-Z/50V	D011223597160S		
C809	00D 963 0293 709	C,ELECT 100UF-M/10V	D040101082070S		
C810	nsp	C,CERAMIC 0.1UF-Z/50V	D011104597160S		
C811,812	00D 963 9004 614	C,CERAMIC 27PF-J/50V	D010270167160S		
C813	nsp	C,CERAMIC 0.1UF-Z/50V	D011104597160S		
C814-816	nsp	C,CERAMIC 0.01UF-K/50V	D011103777160S		
C817	nsp	C,CERAMIC 560PF-J/50V	D010561167160S		
C818	00D 960 9010 010	C,ELECT 4.7UF-M/50V	D0404R7087250S		
C819	nsp	C,CERAMIC 0.01UF-K/50V	D011103777160S		
C820	00D 960 9009 814	C,CERAMIC 330PF-J/50V	D010331167160S		
C821	00D 963 0234 205	C,ELECT 10UF-M/50V	D040100087070S		
C822	00D 963 9005 862	C,ELECT 47UF-M/16V	D040470083080S		

Ref. No.	Part No.	Part Name	Remarks	Q'ty	New
C823	nsp	C,CERAMIC 0.01UF-K/50V	D011103777160S		
C824,825	00D 963 0234 205	C,ELECT 10UF-M/50V	D040100087070S		
C826-831	nsp	C,CERAMIC 100PF-J/50V	D010101167160S		
C836,837	nsp	C,CERAMIC 0.022UF-Z/50V	D011223597160S		
C865L	nsp	C,CERAMIC 120PF-J/50V	D010121167160S		
C865R	nsp	C,CERAMIC 120PF-J/50V	D010121167160S		
C871L	00D 963 0216 304	C,FILM 0.001UF-J/100V	D02010206C060S		
C871R	00D 963 0216 304	C,FILM 0.001UF-J/100V	D02010206C060S		
C916D	nsp	C,CERAMIC 0.1UF-Z/50V	D011104597160S		
C917D	nsp	C,CERAMIC 0.1UF-Z/50V	D011104597160S		
C918D	nsp	C,CERAMIC 0.1UF-Z/50V	D011104597160S		
C921D	nsp	C,CERAMIC 100PF-J/50V	D010101167160S		
C923D	nsp	C,CERAMIC 22PF-J/50V	D010220167160S		
C924D	nsp	C,CERAMIC 22PF-J/50V	D010220167160S		
C927D	00D 963 9005 862	C,ELECT 47UF-M/16V	D040470083080S		
C928D	00D 963 9005 862	C,ELECT 47UF-M/16V	D040470083080S		
C931D	nsp	C,CERAMIC 100PF-J/50V	D010101167160S		
C932D	nsp	C,CERAMIC 0.01UF-K/50V	D011103777160S		
C933D	nsp	C,CERAMIC 0.01UF-K/50V	D011103777160S		
C934D	nsp	C,CERAMIC 0.01UF-K/50V	D011103777160S		
C935D	00D 960 9010 010	C,ELECT 4.7UF-M/50V	D0404R7087250S		
C936D	00D 960 9010 010	C,ELECT 4.7UF-M/50V	D0404R7087250S		
C937D	nsp	C,CERAMIC 1000PF-K/50V	D011102777160S		
C938D	00D 960 9010 010	C,ELECT 4.7UF-M/50V	D0404R7087250S		
C939D	nsp	C,CERAMIC 0.01UF-K/50V	D011103777160S		
C940D	nsp	C,CERAMIC 0.01UF-K/50V	D011103777160S		
C941D	00D 963 0244 606	C,ELECT 0.1UF-M/50V (Pb Free)	D040R10087080S		
C950D	nsp	C,CERAMIC 0.1UF-Z/50V	D011104597160S		
C951D	nsp	C,CERAMIC 0.1UF-Z/50V	D011104597160S		
C952D	00D 963 0234 205	C,ELECT 10UF-M/50V	D040100087070S		
C953D	00D 963 0234 205	C,ELECT 10UF-M/50V	D040100087070S		
C954D	nsp	C,CERAMIC 0.1UF-Z/50V	D011104597160S		
C955D	nsp	C,CERAMIC 0.1UF-Z/50V	D011104597160S		
C956D	nsp	C,CERAMIC 22PF-J/50V	D010220167160S		
C957D	nsp	C,CERAMIC 0.1UF-Z/50V	D011104597160S		
C959D	nsp	C,CERAMIC 22PF-J/50V	D010220167160S		
BC801	00D 254 4666 005	CE04W0H105ZC(FG)	D041105090010S		
OTHERS PARTS GROUP					
BD802-809	nsp	COIL,BEAD MB-160808	D340160800060S		
BD809D	nsp	COIL,BEAD MB-160808	D340160800060S		
BD810-817	nsp	COIL,BEAD MB-160808	D340160800060S		
CN106	nsp	CN.WAFER 5P	L101100030510S		
CN108	00D 963 0085 302	CN.WAFER 17P	L101100031710S		
CP01	nsp	CN.WAFER 16P	L101100040910S		
CP301A	00D 963 0367 400	CN.FPC 35P	L131524923520S		
CP701	nsp	CN.WAFER 19P	L101100041910S		
CP702	nsp	CN.WAFER 15P	L100912150010S		
CP703	nsp	CN.WAFER 8P	L101100040810S		
CP801	00D 963 0149 303	CN.FPC 15P	L131111500010S		
CP802	nsp	CN.WAFER 16P	L100912160010S		
CP803	nsp	CN.WAFER 16P	L101100041610S		

Ref. No.	Part No.	Part Name	Remarks	Q'ty	New
CP804	nsp	CN.WAFER 15P	L100912150010S		
CP805	nsp	CN.WAFER 08P	L100912080010S		
CP1001	nsp	CN.WAFER 8P	L101100040810S		
CP1002	nsp	CN.WAFER 9P	L101100040910S		
JACK801	00D 963 0217 905	TER,RCA 2PIN	G601206A0200YS		
JACK802	00D 963 0294 601	JACK,D3.5 EARPHONE	G40100350000YS		
L801D	nsp	COIL INDUCTOR 4.7UH	D3304R7000150S		
L802D	nsp	COIL INDUCTOR 4.7UH	D3304R7000150S		
L803D	nsp	COIL INDUCTOR 4.7UH	D3304R7000150S		
L805D	nsp	COIL INDUCTOR 4.7UH	D3304R7000150S		
L806D	nsp	COIL INDUCTOR 22UH	D330220010050S		
L807D	nsp	COIL INDUCTOR 22UH	D330220010050S		
TP803	nsp	CN.WAFER 8P	L101220080000S		
TP804	nsp	CN.WAFER 4P	L101220040000S		
X801	00D 963 0217 701	RESONATOR,CERAMIC ZTT12.00MT	E830120000060S		
X802	00D 963 0217 604	CRYSTAL 4.332MHZ,HC-49U	E800433200100S		
OPT801D	00D 963 0237 503	MODULE JSR1165-C	E100116500040S		
OPT802D	00D 963 0237 503	MODULE JSR1165-C	E100116500040S		
	nsp	CN,WIRE 110MM/1P	L000111010010S		

HDMI P.W.B. UNIT ASS'Y

Ref. No.	Part No.	Part Name	Remarks	Q'ty	New
SEMICONDUCTORS GROUP					
IC01	nsp	SII9185CTU	00D2623721007		
IC03	nsp	IC SE1117-1.8	J126111718010S		
IC12	nsp	IC BU4094BCF-E2	J040140940030S		
IC801	nsp	ADSP21367KSZ1A1136	00D2623709016		
IC802	nsp	W9864G2GH-7	00D2623746008		
IC803	nsp	IC EN29LV160T-70TCP	J005291600010S		
IC807	nsp	LC89057W-VF4A	00D2623449004		
IC808	nsp	ADAU1328BSTZ1136	00D2623645015		
IC809-811	nsp	IC SN74LVC244APWR	J040742440230S		
IC812	nsp	IC SN74HCT244PWR	J040742440220S		
IC814,815	nsp	IC SN74HCT00PWR	J040740000210S		
IC816	nsp	74LVX157MTC +C	00D2622870904		
IC823	nsp	IC KIA7805API	J126780500110S		
IC825,826	nsp	IC SN74LVC74APWR	J040747400200S		
IC832	nsp	IC SE1117-33-PF	J126111733020S		
Q01,02	nsp	TR KRC102S	J522010200210S		
Q03,04	nsp	TR KRC104S	J522104S00210S		
Q05	nsp	TR KRA102S(PB)	J520010200210S		
Q06	nsp	TR KTC3875S	J522038750210S		
Q07	nsp	TR KRC104S	J522104S00210S		
Q810D	nsp	TR KRC102S	J522010200210S		
Q811D	nsp	TR KRA102S(PB)	J520010200210S		
Q814D	nsp	TR KRA102S(PB)	J520010200210S		
D01-36	nsp	D,ESD IMSA-6802-01A	K067680200010S		
D44	nsp	D,SWITCHING KDS4148U	K005041480030S		
CAPACITORS GROUP					
C01	nsp	C,CERAMIC 1000PF-K/50V	D011102777160S		
C02-05	nsp	C,CERAMIC 0.1UF-K/50V	D011104577162S		
C06,07	nsp	C,CERAMIC 1000PF-K/50V	D011102777160S		
C08-14	nsp	C,CERAMIC 0.1UF-K/50V	D011104577162S		
C15-17	nsp	C,CERAMIC 1000PF-K/50V	D011102777160S		
C18,19	nsp	C,CERAMIC 0.1UF-K/50V	D011104577162S		
C20	nsp	C,CERAMIC 1000PF-K/50V	D011102777160S		
C21	nsp	C,CERAMIC 100PF-J/50V	D010101167160S		
C22	nsp	C,CERAMIC 1000PF-K/50V	D011102777160S		
C23	nsp	C,CERAMIC 100PF-J/50V	D010101167160S		
C24,25	nsp	C,ELECT 10UF-MVG/16V	D050100083460S		
C26,27	nsp	C,CERAMIC 0.01UF-K/50V	D011103777160S		
C28H	nsp	C,ELECT 10UF-MVG/16V	D050100083460S		
C29	nsp	C,CERAMIC 0.1UF-K/50V	D011104577162S		
C29H	nsp	C,ELECT 10UF-MVG/16V	D050100083460S		
C30	nsp	C,CERAMIC 0.1UF-K/50V	D011104577162S		
C30H	nsp	C,ELECT 10UF-MVG/16V	D050100083460S		
C31,32	nsp	C,CERAMIC 0.1UF-K/50V	D011104577162S		
C63-65	nsp	C,CERAMIC 100PF-J/50V	D010101167160S		
C66	nsp	C,CERAMIC 0.01UF-K/50V	D011103777160S		
C831D	nsp	C,CERAMIC 0.1UF-K/50V	D011104577162S		
C832D	nsp	C,CERAMIC 1000PF-K/50V	D011102177101S		
C833D	nsp	C,CERAMIC 100PF-J/50V	D011101167101S		
C834D	nsp	C,CERAMIC 100PF-J/50V	D011101167101S		

Ref. No.	Part No.	Part Name	Remarks	Q'ty	New
C835D	nsp	C,CERAMIC 0.01UF-K/50V	D011103177101S		
C836D	nsp	C,CERAMIC 0.01UF-K/50V	D011103177101S		
C837D	nsp	C,CERAMIC 100PF-J/50V	D011101167101S		
C838D	nsp	C,CERAMIC 100PF-J/50V	D011101167101S		
C839D	nsp	C,CERAMIC 100PF-J/50V	D011101167101S		
C840D	nsp	C,CERAMIC 100PF-J/50V	D011101167101S		
C841D	nsp	C,CERAMIC 100PF-J/50V	D011101167101S		
C842D	nsp	C,CERAMIC 100PF-J/50V	D011101167101S		
C843D	nsp	C,CERAMIC 100PF-J/50V	D011101167101S		
C844D	nsp	C,CERAMIC 100PF-J/50V	D011101167101S		
C845D	nsp	C,CERAMIC 0.1UF-K/50V	D011104177101S		
C846D	nsp	C,CERAMIC 1000PF-K/50V	D011102177101S		
C847D	nsp	C,CERAMIC 1000PF-K/50V	D011102177101S		
C848D	nsp	C,CERAMIC 1000PF-K/50V	D011102177101S		
C849D	nsp	C,CERAMIC 1000PF-K/50V	D011102177101S		
C850D	nsp	C,CERAMIC 1000PF-K/50V	D011102177101S		
C851D	nsp	C,CERAMIC 1000PF-K/50V	D011102177101S		
C852D	nsp	C,CERAMIC 1000PF-K/50V	D011102177101S		
C853D	nsp	C,CERAMIC 1000PF-K/50V	D011102177101S		
C854D	nsp	C,CERAMIC 0.1UF-K/50V	D011104177101S		
C855D	nsp	C,CERAMIC 0.1UF-K/50V	D011104177101S		
C856D	nsp	C,CERAMIC 0.1UF-K/50V	D011104177101S		
C857D	nsp	C,CERAMIC 0.1UF-K/50V	D011104177101S		
C858D	nsp	C,CERAMIC 0.1UF-K/50V	D011104177101S		
C859D	nsp	C,CERAMIC 0.1UF-K/50V	D011104177101S		
C860D	nsp	C,CERAMIC 0.1UF-K/50V	D011104177101S		
C861D	nsp	C,CERAMIC 0.1UF-K/50V	D011104177101S		
C862D	nsp	C,CERAMIC 0.01UF-K/50V	D011103177101S		
C863D	nsp	C,CERAMIC 100PF-J/50V	D011101167101S		
C864D	nsp	C,CERAMIC 4.7UF-K/10V	D011475572200S		
C865D	nsp	C,CERAMIC 5PF-C/50V	D010050107160S		
C866D	nsp	C,CERAMIC 5PF-C/50V	D010050107160S		
C871D	nsp	C,CERAMIC 0.01UF-K/50V	D011103177101S		
C873D	nsp	C,CERAMIC 0.01UF-K/50V	D011103177101S		
C875D	nsp	C,CERAMIC 4.7UF-K/10V	D011475572200S		
C876D	nsp	C,CERAMIC 0.01UF-K/50V	D011103177101S		
C877D	nsp	C,CERAMIC 0.1UF-K/50V	D011104177101S		
C878D	nsp	C,CERAMIC 0.1UF-K/50V	D011104177101S		
C879D	nsp	C,CERAMIC 0.1UF-K/50V	D011104177101S		
C880D	nsp	C,CERAMIC 0.01UF-K/50V	D011103177101S		
C881D	nsp	C,CERAMIC 0.01UF-K/50V	D011103177101S		
C882D	nsp	C,CERAMIC 6PF-D/50V	D010060117160S		
C883D	nsp	C,CERAMIC 6PF-D/50V	D010060117160S		
C884D	nsp	C,CERAMIC 0.1UF-K/50V	D011104577162S		
C885D	nsp	C,CERAMIC 0.022UF-Z/50V	D011223597160S		
C886D	nsp	C,CERAMIC 0.1UF-K/50V	D011104177101S		
C887D	nsp	C,FILM 0.12UF-J/63V	D020124078060S		
C888D	nsp	C,CERAMIC 0.01UF-K/50V	D011103177101S		
C889D	nsp	C,CERAMIC 100PF-J/50V	D011101167101S		
C890D	nsp	C,CERAMIC 0.01UF-K/50V	D011103177101S		
C891D	nsp	C,CERAMIC 0.01UF-K/50V	D011103177101S		
C892D	nsp	C,CERAMIC 4.7UF-K/10V	D011475572200S		
C893D	nsp	C,CERAMIC 0.1UF-K/50V	D011104177101S		
C895D	nsp	C,CERAMIC 0.1UF-K/50V	D011104177101S		
C896D	nsp	C,CERAMIC 0.01UF-K/50V	D011103177101S		
C897D	nsp	C,CERAMIC 0.1UF-K/50V	D011104177101S		

Ref. No.	Part No.	Part Name	Remarks	Q'ty	New
C898D	nsp	C,CERAMIC 0.1UF-K/50V	D011104177101S		
C899D	nsp	C,CERAMIC 100PF-J/50V	D011101167101S		
C900D	nsp	C,CERAMIC 4.7UF-K/10V	D011475572200S		
C901D	nsp	C,ELECT 100UF-MVG/6.3V	D050101081650S		
C902D	nsp	C,CERAMIC 0.1UF-K/50V	D011104177101S		
C903D	nsp	C,CERAMIC 0.1UF-K/50V	D011104177101S		
C904D	nsp	C,CERAMIC 5600PF-K/50V	D011562777160S		
C905D	nsp	C,CERAMIC 390PF-J/50V	D010391167160S		
C906D	nsp	C,CERAMIC 0.1UF-K/50V	D011104177101S		
C907D	nsp	C,CERAMIC 0.1UF-K/50V	D011104177101S		
C908D	nsp	C,ELECT 47UF-MVG/6.3V	D050470081460S		
C909D	nsp	C,CERAMIC 0.1UF-K/50V	D011104177101S		
C910D	nsp	C,ELECT 10UF-MVG/16V	D050100083460S		
C911D	nsp	C,CERAMIC 0.01UF-K/50V	D011103177101S		
C913D	nsp	C,ELECT 10UF-MVG/16V	D050100083460S		
C914D	nsp	C,CERAMIC 0.01UF-K/50V	D011103177101S		
C915D	nsp	C,ELECT 10UF-MVG/16V	D050100083460S		
OTHERS PARTS GROUP					
BD801	nsp	COIL,BEAD MB-160808	D340160800060S		
BD807D	nsp	COIL,BEAD MB-160808	D340160800060S		
BD808D-03	nsp	COIL,BEAD MB-160808	D340160800060S		
CB06	nsp	COIL,BEAD MB-160808	D340160800060S		
CN01	nsp	CN.WAFER 9P	L101100030910S		
CN802	nsp	CN.HOUSING 16P	L120912160010S		
CN803	nsp	CN.WAFER 16P	L101100031610S		
CN804	nsp	CN.HOUSING 15P	L120912150010S		
CN805	nsp	CN.HOUSING 08P	L120912080010S		
CP404	nsp	CN.WAFER 4P	L101220040000S		
CP405	nsp	CN.WAFER 5P	L101220050000S		
CP904		CN.WAFER 6P	L101220060010S		
J806	nsp	R,THICK 0-J,1/16W	C20000006M101S		
JACK01-03	00D 963 0388 504	19PIN HDMI CONNECTOR	L109040000020S		
TP801	nsp	CN.WAFER 13P	L101530141310S		
X803D	nsp	FCX-03(16.660MHz)	00D3991091905		
X804D	nsp	FCX-03(24.576MHz)	00D3991053901		

VIDEO P.W.B. UNIT ASS'Y

Ref. No.	Part No.	Part Name	Remarks	Q'ty	New
SEMICONDUCTORS GROUP					
IC1001	00D 963 0133 500	IC BA7626FP	J171762600010S		
IC1002	00D 963 0068 002	IC BU4052BCF-E2	J040405200060S		
IC1003	00D 963 0074 504	IC BU2090F-E2	J044209000010S		
IC1005,1006	00D 963 0133 500	IC BA7626FP	J171762600010S		
IC1007	00D 963 0068 002	IC BU4052BCF-E2 P	J040405200060S		
IC1008	00D 963 0340 801	IC NJW1321FP1	J171132100010S		
IC1011,1012	00D 263 1082 903	TK15420MTL +C	J127154200010S		
IC1013	00D 963 0367 503	IC SE1117-1.8	J126111718010S		
IC1014	00D 963 0111 603	IC SE1117-33-PF	J126111733020S		
IC1016	00D 963 0295 406	IC IC BH7868FS	J127786800000S		
IC1017	00D 262 3425 905	LTC4300-2CMS8	J040430000000S		
IC1018	00D 262 3643 004	ADV7180BSTZ	J044718000010S		
IC1019	00D 262 3644 003	ADV7172KSTZ	J045717200011S		
IC1151	00D 263 1082 903	TK15420MTL +C	J127154200010S		
IC1157	00D 263 1082 903	TK15420MTL +C	J127154200010S		
IC1160	00D 263 1082 903	TK15420MTL +C	J127154200010S		
IC1162,1163	00D 263 1082 903	TK15420MTL +C	J127154200010S		
IC1164	00D 963 0327 604	IC NJM2581M	J127258100010S		
Q1001	00D 963 0148 508	TR KTA1504S	J520015040150S		
Q1002	00D 960 0296 309	TR KRC111S (NM)	J522011100210S		
Q1003,1004	00D 963 0120 704	TR KRA102S(PB)	J520010200210S		
Q1005,1006	00D 963 0102 803	TR 2SA933S	J5000933S0050S		
Q1011,1012	00D 963 0120 704	TR KRA102S(PB)	J520010200210S		
Q1013,1014	00D 963 0148 508	TR KTA1504S	J520015040150S		
Q1015,1016	00D 960 0296 309	TR KRC111S (NM)	J522011100210S		
Q1017	00D 963 0120 801	TR KRC102S	J522010200210S		
Q1018	00D 963 0121 606	TR KRC107S	J522107S00210S		
Q1019	00D 963 0102 803	TR 2SA933S	J5000933S0050S		
Q1020	00D 960 0285 006	TR KRC104S	J522104S00210S		
Q1021-1025	00D 963 0148 508	TR KTA1504S	J520015040150S		
Q1026	00D 960 0285 006	TR KRC104S	J522104S00210S		
D1001	00D 963 0355 401	D,SWITCHING KDS4148U	K005041480030S		
D1005	00D 963 0355 401	D,SWITCHING KDS4148U	K005041480030S		
D1009,1010	00D 963 9006 599	R,CHIP THICK 0-J,1/10W	C200000060200S		
D1011-1014	00D 963 0341 004	D,SWITCHING KDS4148U	K005041480030S		
D1021-1024	00D 963 0355 401	D,SWITCHING KDS4148U	K005041480030S		
RESISTORS GROUP					
R1008	00D 963 9005 639	R,METAL FILM 100-J,1W	C060010165060S		
R1096	00D 963 9005 639	R,METAL FILM 100-J,1W	C060010165060S		
R1100	00D 963 9005 639	R,METAL FILM 100-J,1W	C060010165060S		
VR1001-1005	00D 963 0367 606	R,THICK 220-F,1/16W	C20002214M161S		
CAPACITORS GROUP					
C1002-1004	00D 963 9006 544	C,ELECT 22UF-M/25V	D040220084050S		
C1005	00D 960 0298 802	C,ELECT 470UF-M/6.3V	D040471081070S		
C1006	00D 963 0234 205	C,ELECT 10UF-M/50V	D040100087070S		
C1007,1008	nsp	C,CERAMIC 0.01UF-K/50V	D011103777160S		
C1009	00D 963 0293 602	C,ELECT 1UF-M/50V (Pb Free)	D040010087150S		

Ref. No.	Part No.	Part Name	Remarks	Q'ty	New
C1010	00D 963 0293 709	C,ELECT 100UF-M/10V	D040101082070S		
C1011	nsp	C,CERAMIC 0.047UF-Z/50V	D011473597160S		
C1012,1013	nsp	C,CERAMIC 0.01UF-K/50V	D011103777160S		
C1014,1015	nsp	C,CERAMIC 100PF-J/50V	D010101167160S		
C1016,1017	nsp	C,CERAMIC 0.01UF-K/50V	D011103777160S		
C1018	00D 963 0293 709	C,ELECT 100UF-M/10V	D040101082070S		
C1019,1020	00D 963 9006 544	C,ELECT 22UF-M/25V	D040220084050S		
C1021	00D 963 0293 709	C,ELECT 100UF-M/10V	D040101082070S		
C1022	nsp	C,CERAMIC 0.01UF-K/50V	D011103777160S		
C1023-1025	00D 963 0293 709	C,ELECT 100UF-M/10V	D040101082070S		
C1026	nsp	C,CERAMIC 0.01UF-K/50V	D011103777160S		
C1027,1028	00D 963 9006 544	C,ELECT 22UF-M/25V	D040220084050S		
C1029,1030	nsp	C,CERAMIC 0.01UF-K/50V	D011103777160S		
C1032,1033	00D 963 0234 205	C,ELECT 10UF-M/50V	D040100087070S		
C1035,1036	00D 963 0294 106	C,ELECT 2.2UF-M/50V (Pb Free)	D0402R2087160S		
C1037	nsp	C,CERAMIC 0.01UF-K/50V	D011103777160S		
C1038,1039	00D 963 0234 205	C,ELECT 10UF-M/50V	D040100087070S		
C1041	00D 960 0298 802	C,ELECT 470UF-M/6.3V	D040471081070S		
C1042	00D 960 9010 023	C,ELECT 0.47UF-M/50V	D040R47087050S		
C1043,1044	00D 963 0234 205	C,ELECT 10UF-M/50V	D040100087070S		
C1045-1050	00D 963 9006 544	C,ELECT 22UF-M/25V	D040220084050S		
C1051,1052	nsp	C,CERAMIC 0.01UF-K/50V	D011103777160S		
C1053,1054	00D 963 0293 602	C,ELECT 1UF-M/50V (Pb Free)	D040010087150S		
C1055,1056	nsp	C,CERAMIC 0.047UF-Z/50V	D011473597160S		
C1057,1058	nsp	C,CERAMIC 0.01UF-K/50V	D011103777160S		
C1059,1060	00D 963 0223 009	R,THICK 0-J,1/16W	C20000006M160S		
C1061-1069	nsp	C,CERAMIC 0.1UF-K/50V	D011104577160S		
C1070-1078	00D 963 0234 205	C,ELECT 10UF-M/50V	D040100087070S		
C1079-1082	nsp	C,CERAMIC 0.1UF-K/50V	D011104577160S		
C1083	00D 963 0276 409	C,ELECT 100UF-M/16V	D040101083090S		
C1084,1085	nsp	C,CERAMIC 0.1UF-K/50V	D011104577160S		
C1086	00D 963 0234 205	C,ELECT 10UF-M/50V	D040100087070S		
C1087	nsp	C,CERAMIC 0.1UF-K/50V	D011104577160S		
C1088	00D 963 0234 205	C,ELECT 10UF-M/50V	D040100087070S		
C1089	nsp	C,CERAMIC 0.1UF-K/50V	D011104577160S		
C1090	00D 963 0234 205	C,ELECT 10UF-M/50V	D040100087070S		
C1091	nsp	C,CERAMIC 0.1UF-K/50V	D011104577160S		
C1092	00D 963 0276 409	C,ELECT 100UF-M/16V	D040101083090S		
C1093	00D 963 0293 602	C,ELECT 1UF-M/50V (Pb Free)	D040010087150S		
C1094	nsp	C,CERAMIC 0.047UF-Z/50V	D011473597160S		
C1095-1097	nsp	C,CERAMIC 0.01UF-K/50V	D011103777160S		
C1098	00D 963 0293 602	C,ELECT 1UF-M/50V (Pb Free)	D040010087150S		
C1099-1101	00D 963 0293 709	C,ELECT 100UF-M/10V	D040101082070S		
C1102	nsp	C,CERAMIC 0.01UF-K/50V	D011103777160S		
C1103	00D 963 9006 544	C,ELECT 22UF-M/25V	D040220084050S		
C1104	00D 963 0293 709	C,ELECT 100UF-M/10V	D040101082070S		
C1105	00D 963 9006 544	C,ELECT 22UF-M/25V	D040220084050S		
C1106	00D 963 0293 709	C,ELECT 100UF-M/10V	D040101082070S		
C1107	00D 963 9006 544	C,ELECT 22UF-M/25V	D040220084050S		
C1108,1109	00D 963 0293 709	C,ELECT 100UF-M/10V	D040101082070S		
C1113	00D 963 0144 706	C,FILM MI-0.01UF-J/50V	D020103167050S		
C1114	nsp	C,CERAMIC 100PF-J/50V	D010101167160S		
C1115	00D 963 0130 105	C,FILM 1UF-K/63V	D020105078060S		
C1116	nsp	C,CERAMIC 0.01UF-K/50V	D011103777160S		
C1117	nsp	C,CERAMIC 100PF-J/50V	D010101167160S		
C1118	00D 963 0024 907	C,ELECT 1000UF-M/6.3V	D040102081060S		

Ref. No.	Part No.	Part Name	Remarks	Q'ty	New
C1119,1120	nsp	C,CERAMIC 0.1UF-K/50V	D011104577160S		
C1121,1122	00D 963 0234 108	C,FILM MI-0.1UF-J/50V	D020104167050S		
C1123	nsp	C,CERAMIC 0.047UF-Z/50V	D011473597160S		
C1124-1126	00D 963 0234 205	C,ELECT 10UF-M/50V	D040100087070S		
C1127	00D 963 9006 544	C,ELECT 22UF-M/25V	D040220084050S		
C1128	00D 963 0234 205	C,ELECT 10UF-M/50V	D040100087070S		
C1129,1130	00D 963 9006 557	C,ELECT 220UF-M/6.3V	D040221081060S		
C1131	00D 963 0324 403	C,ELECT 33UF-M/35V	D040330085050S		
C1132,1133	00D 963 0144 706	C,FILM MI-0.01UF-J/50V	D020103167050S		
C1134	00D 960 0298 802	C,ELECT 470UF-M/6.3V	D040471081070S		
C1135	00D 963 0144 706	C,FILM MI-0.01UF-J/50V	D020103167050S		
C1136,1137	nsp	C,CERAMIC 0.1UF-K/50V	D011104577160S		
C1138	00D 963 0234 205	C,ELECT 10UF-M/50V	D040100087070S		
C1139,1140	nsp	C,CERAMIC 0.1UF-K/50V	D011104577160S		
C1141	nsp	C,CERAMIC 0.01UF-K/50V	D011103777160S		
C1142	00D 963 0234 108	C,FILM MI-0.1UF-J/50V	D020104167050S		
C1143	nsp	C,CERAMIC 0.1UF-K/50V	D011104577160S		
C1144	00D 963 0324 403	C,ELECT 33UF-M/35V	D040330085050S		
C1145	00D 960 0298 802	C,ELECT 470UF-M/6.3V	D040471081070S		
C1146	nsp	C,CERAMIC 1000PF-K/50V	D011102777160S		
C1147	nsp	C,CERAMIC 0.01UF-K/50V	D011103777160S		
C1148	00D 963 0324 403	C,ELECT 33UF-M/35V	D040330085050S		
C1149	nsp	C,CERAMIC 0.1UF-K/50V	D011104577160S		
C1150	nsp	C,CERAMIC 0.01UF-K/50V	D011103777160S		
C1151	nsp	C,CERAMIC 0.1UF-K/50V	D011104577160S		
C1152	00D 963 0303 000	C,CERAMIC 0.082UF-K/50V	D010823777160S		
C1153	nsp	C,CERAMIC 0.01UF-K/50V	D011103777160S		
C1154	nsp	C,CERAMIC 1000PF-K/50V	D011102777160S		
C1155	nsp	C,CERAMIC 0.01UF-K/50V	D011103777160S		
C1156,1157	00D 963 0234 108	C,FILM MI-0.1UF-J/50V	D020104167050S		
C1158	nsp	C,CERAMIC 0.1UF-K/50V	D011104577160S		
C1159	nsp	C,CERAMIC 1000PF-K/50V	D011102777160S		
C1160	nsp	C,CERAMIC 100PF-J/50V	D010101167160S		
C1161	nsp	C,CERAMIC 1000PF-K/50V	D011102777160S		
C1162	nsp	C,CERAMIC 0.1UF-K/50V	D011104577160S		
C1163	nsp	C,CERAMIC 100PF-J/50V	D010101167160S		
C1164,1165	nsp	C,CERAMIC 47PF-J/50V	D010470167160S		
C1166,1167	nsp	C,CERAMIC 0.1UF-K/50V	D011104577160S		
C1168	nsp	C,CERAMIC 1000PF-K/50V	D011102777160S		
C1169	nsp	C,CERAMIC 0.01UF-K/50V	D011103777160S		
C1170	nsp	C,CERAMIC 0.1UF-K/50V	D011104577160S		
C1171	nsp	C,CERAMIC 1000PF-K/50V	D011102777160S		
C1172,1173	00D 960 0298 802	C,ELECT 470UF-M/6.3V	D040471081070S		
C1174-1176	00D 963 0234 108	C,FILM MI-0.1UF-J/50V	D020104167050S		
C1177	nsp	C,CERAMIC 0.01UF-K/50V	D011103777160S		
C1178	nsp	C,CERAMIC 0.1UF-K/50V	D011104577160S		
C1179	nsp	C,CERAMIC 1000PF-K/50V	D011102777160S		
C1180	nsp	C,CERAMIC 0.1UF-K/50V	D011104577160S		
C1181,1182	nsp	C,CERAMIC 1000PF-K/50V	D011102777160S		
C1183	nsp	C,CERAMIC 0.1UF-K/50V	D011104577160S		
C1184	nsp	C,CERAMIC 100PF-J/50V	D010101167160S		
C1185	nsp	C,CERAMIC 1000PF-K/50V	D011102777160S		
C1186	nsp	C,CERAMIC 100PF-J/50V	D010101167160S		
C1187-1189	nsp	C,CERAMIC 0.1UF-K/50V	D011104577160S		
C1190,1191	nsp	C,CERAMIC 1000PF-K/50V	D011102777160S		
C1192-1194	nsp	C,CERAMIC 0.1UF-K/50V	D011104577160S		

Ref. No.	Part No.	Part Name	Remarks	Q'ty	New
C1198-1200	nsp	C,CERAMIC 0.01UF-K/50V	D011103777160S		
C1201,1202	00D 963 0324 403	C,ELECT 33UF-M/35V	D040330085050S		
C1203-1206	nsp	C,CERAMIC 0.01UF-K/50V	D011103777160S		
C1207	00D 963 0276 409	C,ELECT 100UF-M/16V	D040101083090S		
C1208	nsp	C,CERAMIC 0.01UF-K/50V	D011103777160S		
C1209	00D 963 0276 409	C,ELECT 100UF-M/16V	D040101083090S		
C1210	nsp	C,CERAMIC 0.01UF-K/50V	D011103777160S		
C1211	00D 963 0276 409	C,ELECT 100UF-M/16V	D040101083090S		
OTHERS PARTS GROUP					
BD1001-1003	nsp	COIL,BEAD MB-160808	D340160800060S		
CN406	nsp	CN,WIRE 300MM/3P	L000301030060S		
CN1001	nsp	CN.WAFER 8P	L101100030810S		
CN1002	nsp	CN.WAFER 9P	L101100030910S		
CP514	nsp	CN.WAFER 8P	L101220080010S		
JACK1001,1002	00D 963 0367 709	TER,RCA 6PIN	G603610D0032YS		
JACK1003	00D 963 0218 001	TER,RCA 2PIN	G60122001000YS		
JACK1004	00D 963 0218 108	TER,RCA 3PIN	G60630401000YS		
L1003-1006	nsp	COIL INDUCTOR 22UH	D330220010520S		
X1011	00D 963 0294 407	CRYSTAL 28.63636MHZ	E80028R636010S		

HDMI_PWR P.W.B. UNIT ASS'Y

Ref. No.	Part No.	Part Name	Remarks	Q'ty	New
SEMICONDUCTORS GROUP					
IC401H1	00D9630366500	IC KIA1117PI33	J126111733050S		
CAPACITORS GROUP					
C405H1	00D9630234205	C,ELECT 10UF-M/50V	D040100087070S		
C406H1	00D9630233303	C,CERAMIC 0.01UF-M/16V	D005103773530S		
OTHERS PARTS GROUP					
CN404	nsp	CN,WIRE 300MM/4P	L000301040110S		
CP513	nsp	CN.WAFER 3P ANGLE	L102526803010S		

PARTS LIST OF P.W.B. UNIT



AVR-688 E3 MODEL

* 本表に "nsp" と記載されている部品は供給できません。

* Parts for which "nsp" is indicated on this table cannot be supplied.

* 本表に記載されている部品は、補修用部品のため製品に使用している部品とは一部、形状、寸法などが異なる場合があります。

* The parts listed below are for maintenance only, might differ from the parts used in the unit in appearances or dimensions.

MAIN P.W.B. UNIT ASS'Y

Ref. No.	Part No.	Part Name	Remarks	Q'ty	New
SEMICONDUCTORS GROUP					
IC110,111	00D 963 0218 807	IC BU4094BCF-E2	J040140940030S		
IC231	00D 960 0174 104	IC CXA1511M-T4	J030151100010S		
Q101	00D 960 0196 302	TR KTA1268BL	J5001268B0050S		
Q102-104	00D 960 0196 700	TR KTC3200BL	J5023200B0050S		
Q104C	00D 960 0196 506	TR KSC1845F	J5021845F0000S		
Q104FL	00D 960 0196 506	TR KSC1845F	J5021845F0000S		
Q104FR	00D 960 0196 506	TR KSC1845F	J5021845F0000S		
Q104SL	00D 960 0196 506	TR KSC1845F	J5021845F0000S		
Q104SR	00D 960 0196 506	TR KSC1845F	J5021845F0000S		
Q105	00D 960 0196 700	TR KTC3200BL	J5023200B0050S		
Q105C	00D 960 0196 603	TR KTC2874B	J502287400010S		
Q105FL	00D 960 0196 603	TR KTC2874B	J502287400010S		
Q105FR	00D 960 0196 603	TR KTC2874B	J502287400010S		
Q105SL	00D 960 0196 603	TR KTC2874B	J502287400010S		
Q105SR	00D 960 0196 603	TR KTC2874B	J502287400010S		
Q106	00D 960 0196 700	TR KTC3200BL	J5023200B0050S		
Q106C	00D 960 0196 205	TR KSA992F	J5000992F0050S		
Q106FL	00D 960 0196 205	TR KSA992F	J5000992F0050S		
Q106FR	00D 960 0196 205	TR KSA992F	J5000992F0050S		
Q106SL	00D 960 0196 205	TR KSA992F	J5000992F0050S		
Q106SR	00D 960 0196 205	TR KSA992F	J5000992F0050S		
Q107	00D 960 0196 700	TR KTC3200BL	J5023200B0050S		
Q107C	00D 960 0196 205	TR KSA992F	J5000992F0050S		
Q107FL	00D 960 0196 205	TR KSA992F	J5000992F0050S		
Q107FR	00D 960 0196 205	TR KSA992F	J5000992F0050S		
Q107SL	00D 960 0196 205	TR KSA992F	J5000992F0050S		
Q107SR	00D 960 0196 205	TR KSA992F	J5000992F0050S		
Q108	00D 960 0196 700	TR KTC3200BL	J5023200B0050S		
Q108C	00D 960 0196 506	TR KSC1845F	J5021845F0000S		
Q108FL	00D 960 0196 506	TR KSC1845F	J5021845F0000S		
Q108FR	00D 960 0196 506	TR KSC1845F	J5021845F0000S		
Q108SL	00D 960 0196 506	TR KSC1845F	J5021845F0000S		
Q108SR	00D 960 0196 506	TR KSC1845F	J5021845F0000S		
Q109,110	00D 960 0196 700	TR KTC3200BL	J5023200B0050S		
Q111	00D 960 0196 302	TR KTA1268BL	J5001268B0050S		
Q128	00D 960 0097 207	TR KRA102M	J6002202M0010S		
Q130	00D 960 0196 302	TR KTA1268BL	J5001268B0050S		
Q131,132	00D 963 0219 602	TR KRC106M	J6020106M0010S		
Q133-137	00D 960 0097 207	TR KRA102M	J6002202M0010S		
Q141SW	00D 963 0044 301	TR KTC2875B(MB)	J5222875B0010S		
Q142	00D 960 0196 700	TR KTC3200BL	J5023200B0050S		
Q142SW	00D 963 0044 301	TR KTC2875B(MB)	J5222875B0010S		
Q143,144	00D 960 0196 302	TR KTA1268BL	J5001268B0050S		
Q145	00D 960 0196 700	TR KTC3200BL	J5023200B0050S		
Q146,147	00D 960 0196 302	TR KTA1268BL	J5001268B0050S		
Q151	00D 960 0196 302	TR KTA1268BL	J5001268B0050S		
Q156	00D 960 0097 304	TR KRC102M	J6020102M0010S		

Ref. No.	Part No.	Part Name	Remarks	Q'ty	New
Q165	00D 960 0196 700	TR KTC3200BL	J5023200B0050S		
Q166-171	00D 960 0196 302	TR KTA1268BL	J5001268B0050S		
Q221L	00D 963 0044 301	TR KTC2875B(MB)	J5222875B0010S		
Q221R	00D 963 0044 301	TR KTC2875B(MB)	J5222875B0010S		
Q227L	00D 963 0044 301	TR KTC2875B(MB)	J5222875B0010S		
Q227R	00D 963 0044 301	TR KTC2875B(MB)	J5222875B0010S		
Q231	00D 960 0097 003	TR KRA104M	J6000104M0010S		
Q541	00D 963 0121 208	TR KRC107M	J6020107M0010S		
D101C	00D 963 0355 401	D,SWITCHING KDS4148U	K005041480030S		
D101FL	00D 963 0355 401	D,SWITCHING KDS4148U	K005041480030S		
D101FR	00D 963 0355 401	D,SWITCHING KDS4148U	K005041480030S		
D101SL	00D 963 0355 401	D,SWITCHING KDS4148U	K005041480030S		
D101SR	00D 963 0355 401	D,SWITCHING KDS4148U	K005041480030S		
D102C	00D 963 0355 401	D,SWITCHING KDS4148U	K005041480030S		
D102FL	00D 963 0355 401	D,SWITCHING KDS4148U	K005041480030S		
D102FR	00D 963 0355 401	D,SWITCHING KDS4148U	K005041480030S		
D102SL	00D 963 0355 401	D,SWITCHING KDS4148U	K005041480030S		
D102SR	00D 963 0355 401	D,SWITCHING KDS4148U	K005041480030S		
D105C	00D 963 0020 309	D,SWITCHING 1SS133T	K000013300520S		
D105FL	00D 963 0020 309	D,SWITCHING 1SS133T	K000013300520S		
D105FR	00D 963 0020 309	D,SWITCHING 1SS133T	K000013300520S		
D105SL	00D 963 0020 309	D,SWITCHING 1SS133T	K000013300520S		
D105SR	00D 963 0020 309	D,SWITCHING 1SS133T	K000013300520S		
D106,107	00D 963 0355 401	D,SWITCHING KDS4148U	K005041480030S		
D114,115	00D 960 0197 107	D,RECTIFIER BRIDGE KBPC604	K047604000020S		
D139	00D 963 0020 309	D,SWITCHING 1SS133T	K000013300520S		
D140,141	00D 963 0328 409	D,SWITCHING 1N4007	K000400700010S		
D142	00D 963 0355 401	D,SWITCHING KDS4148U	K005041480030S		
D143-152	00D 963 0020 309	D,SWITCHING 1SS133T	K000013300520S		
D153	00D 963 0355 401	D,SWITCHING KDS4148U	K005041480030S		
D154-157	00D 963 0020 309	D,SWITCHING 1SS133T	K000013300520S		
D231	00D 963 0355 401	D,SWITCHING KDS4148U	K005041480030S		
D541	00D 963 0355 401	D,SWITCHING KDS4148U	K005041480030S		
ZD101	00D 963 0058 601	D,ZENER MTZJ12B	K06012R044520S		
ZD101C	00D 963 0367 008	D,ZENER 0.2W 3.3V UDZ	K06603R34P400S		
ZD101FL	00D 963 0367 008	D,ZENER 0.2W 3.3V UDZ	K06603R34P400S		
ZD101FR	00D 963 0367 008	D,ZENER 0.2W 3.3V UDZ	K06603R34P400S		
ZD101SL	00D 963 0367 008	D,ZENER 0.2W 3.3V UDZ	K06603R34P400S		
ZD101SR	00D 963 0367 008	D,ZENER 0.2W 3.3V UDZ	K06603R34P400S		
ZD102C	00D 963 0367 008	D,ZENER 0.2W 3.3V UDZ	K06603R04P400S		
ZD102FL	00D 963 0367 008	D,ZENER 0.2W 3.3V UDZ	K06603R04P400S		
ZD102FR	00D 963 0367 008	D,ZENER 0.2W 3.3V UDZ	K06603R04P400S		
ZD102SL	00D 963 0367 008	D,ZENER 0.2W 3.3V UDZ	K06603R04P400S		
ZD102SR	00D 963 0367 008	D,ZENER 0.2W 3.3V UDZ	K06603R04P400S		
ZD105	00D 960 0095 500	D,ZENER MTZJ5.1B	K06005R144520S		
ZD231	00D 960 0095 704	D,ZENER MTZJ6.2B	K06006R244520S		
RESISTORS GROUP					
R101	00D 963 0337 801	R,METAL FILM 100-J,2W	C060010166520S		
R103	00D 963 9005 639	R,METAL FILM 100-J,1W	C060010165060S		
R104	00D 963 0215 907	R,METAL FILM 4.7-J,1W	C0604R7065050S		
R104C	00D 963 9006 285	R,FIXED 1WJ-5.6K	N113135656220S		
R104FL	00D 963 9006 285	R,FIXED 1WJ-5.6K	N113135656220S		

Ref. No.	Part No.	Part Name	Remarks	Q'ty	New
R104FR	00D 963 9006 285	R,FIXED 1WJ-5.6K	N113135656220S		
R104SL	00D 963 9006 285	R,FIXED 1WJ-5.6K	N113135656220S		
R104SR	00D 963 9006 285	R,FIXED 1WJ-5.6K	N113135656220S		
R105	00D 963 0232 906	R,METAL FILM 47K-F,1/4W	C060047343530S		
R105C	00D 963 9006 285	R,FIXED 1WJ-5.6K	N113135656220S		
R105FL	00D 963 9006 285	R,FIXED 1WJ-5.6K	N113135656220S		
R105FR	00D 963 9006 285	R,FIXED 1WJ-5.6K	N113135656220S		
R105SL	00D 963 9006 285	R,FIXED 1WJ-5.6K	N113135656220S		
R105SR	00D 963 9006 285	R,FIXED 1WJ-5.6K	N113135656220S		
R106C	00D 963 0215 907	R,METAL FILM 4.7-J,1W	C0604R7065050S		
R106FL	00D 963 0215 907	R,METAL FILM 4.7-J,1W	C0604R7065050S		
R106FR	00D 963 0215 907	R,METAL FILM 4.7-J,1W	C0604R7065050S		
R106SL	00D 963 0215 907	R,METAL FILM 4.7-J,1W	C0604R7065050S		
R106SR	00D 963 0215 907	R,METAL FILM 4.7-J,1W	C0604R7065050S		
R107C	00D 963 0215 907	R,METAL FILM 4.7-J,1W	C0604R7065050S		
R107FL	00D 963 0215 907	R,METAL FILM 4.7-J,1W	C0604R7065050S		
R107FR	00D 963 0215 907	R,METAL FILM 4.7-J,1W	C0604R7065050S		
R107SL	00D 963 0215 907	R,METAL FILM 4.7-J,1W	C0604R7065050S		
R107SR	00D 963 0215 907	R,METAL FILM 4.7-J,1W	C0604R7065050S		
R108C	00D 963 0345 903	R,FIXED 2WJ-0.47	N113136647820S		
R108FL	00D 963 0345 903	R,FIXED 2WJ-0.47	N113136647820S		
R108FR	00D 963 0345 903	R,FIXED 2WJ-0.47	N113136647820S		
R108SL	00D 963 0345 903	R,FIXED 2WJ-0.47	N113136647820S		
R108SR	00D 963 0345 903	R,FIXED 2WJ-0.47	N113136647820S		
R109C	00D 963 0345 903	R,FIXED 2WJ-0.47	N113136647820S		
R109FL	00D 963 0345 903	R,FIXED 2WJ-0.47	N113136647820S		
R109FR	00D 963 0345 903	R,FIXED 2WJ-0.47	N113136647820S		
R109SL	00D 963 0345 903	R,FIXED 2WJ-0.47	N113136647820S		
R109SR	00D 963 0345 903	R,FIXED 2WJ-0.47	N113136647820S		
R110C	00D 963 0345 903	R,FIXED 2WJ-0.47	N113136647820S		
R110FL	00D 963 0345 903	R,FIXED 2WJ-0.47	N113136647820S		
R110FR	00D 963 0345 903	R,FIXED 2WJ-0.47	N113136647820S		
R110SL	00D 963 0345 903	R,FIXED 2WJ-0.47	N113136647820S		
R110SR	00D 963 0345 903	R,FIXED 2WJ-0.47	N113136647820S		
R111C	00D 963 0345 903	R,FIXED 2WJ-0.47	N113136647820S		
R111FL	00D 963 0345 903	R,FIXED 2WJ-0.47	N113136647820S		
R111FR	00D 963 0345 903	R,FIXED 2WJ-0.47	N113136647820S		
R111SL	00D 963 0345 903	R,FIXED 2WJ-0.47	N113136647820S		
R111SR	00D 963 0345 903	R,FIXED 2WJ-0.47	N113136647820S		
R117,118	00D 963 0144 502	R,CEMENT 0.1-J 5W	C141R10069000S		
R118C	00D 963 9006 256	R,FIXED 1WJ-10	N113135610020S		
R118FL	00D 963 9006 256	R,FIXED 1WJ-10	N113135610020S		
R118FR	00D 963 9006 256	R,FIXED 1WJ-10	N113135610020S		
R118SL	00D 963 9006 256	R,FIXED 1WJ-10	N113135610020S		
R118SR	00D 963 9006 256	R,FIXED 1WJ-10	N113135610020S		
R119C	00D 963 9006 256	R,FIXED 1WJ-10	N113135610020S		
R119FL	00D 963 9006 256	R,FIXED 1WJ-10	N113135610020S		
R119FR	00D 963 9006 256	R,FIXED 1WJ-10	N113135610020S		
R119SL	00D 963 9006 256	R,FIXED 1WJ-10	N113135610020S		
R119SR	00D 963 9006 256	R,FIXED 1WJ-10	N113135610020S		
R127C	00D 963 9005 642	R,METAL FILM 1.2K-J,1W	C060012265050S		
R127FL	00D 963 9005 642	R,METAL FILM 1.2K-J,1W	C060012265050S		
R127FR	00D 963 9005 642	R,METAL FILM 1.2K-J,1W	C060012265050S		
R127SL	00D 963 9005 642	R,METAL FILM 1.2K-J,1W	C060012265050S		
R127SR	00D 963 9005 642	R,METAL FILM 1.2K-J,1W	C060012265050S		
R132C	00D 960 9010 719	R,METAL FILM 47-J,1W	C060047065060S		

Ref. No.	Part No.	Part Name	Remarks	Q'ty	New
R132FL	00D 960 9010 719	R,METAL FILM 47-J,1W	C060047065060S		
R132FR	00D 960 9010 719	R,METAL FILM 47-J,1W	C060047065060S		
R132SL	00D 960 9010 719	R,METAL FILM 47-J,1W	C060047065060S		
R132SR	00D 960 9010 719	R,METAL FILM 47-J,1W	C060047065060S		
R147-149	00D 963 9005 642	R,METAL FILM 1.2K-J,1W	C060012265050S		
VR101C	00D 960 0221 109	VR,SEMI CARBON EVN-DJAA03B	C541102115000S		
VR101FL	00D 960 0221 109	VR,SEMI CARBON EVN-DJAA03B	C541102115000S		
VR101FR	00D 960 0221 109	VR,SEMI CARBON EVN-DJAA03B	C541102115000S		
VR101SL	00D 960 0221 109	VR,SEMI CARBON EVN-DJAA03B	C541102115000S		
VR101SR	00D 960 0221 109	VR,SEMI CARBON EVN-DJAA03B	C541102115000S		
CAPACITORS GROUP					
C101	00D 963 9005 804	C,ELECT 100UF-M/25V	D040101084060S		
C101C	00D 963 0234 506	C,ELECT 47UF-M/50V (Pb Free)	D040470087070S		
C101FL	00D 963 0234 506	C,ELECT 47UF-M/50V (Pb Free)	D040470087070S		
C101FR	00D 963 0234 506	C,ELECT 47UF-M/50V (Pb Free)	D040470087070S		
C101SL	00D 963 0234 506	C,ELECT 47UF-M/50V (Pb Free)	D040470087070S		
C101SR	00D 963 0234 506	C,ELECT 47UF-M/50V (Pb Free)	D040470087070S		
C102	00D 963 0224 503	C,ELECT 22UF-M/50V	D040220087060S		
C102C	00D 963 0234 205	C,ELECT 10UF-M/50V	D040100087070S		
C102FL	00D 960 9010 133	C,ELECT 220UF-M/35V	D040221085060S		
C102FR	00D 960 9010 133	C,ELECT 220UF-M/35V	D040221085060S		
C102SL	00D 963 0234 205	C,ELECT 10UF-M/50V	D040100087070S		
C102SR	00D 963 0234 205	C,ELECT 10UF-M/50V	D040100087070S		
C103	00D 963 9006 557	C,ELECT 220UF-M/6.3V	D040221081060S		
C103C	00D 963 9003 084	C,CERAMIC 100PF-K/500V	D00410106D050S		
C103FL	00D 963 9003 084	C,CERAMIC 100PF-K/500V	D00410106D050S		
C103FR	00D 963 9003 084	C,CERAMIC 100PF-K/500V	D00410106D050S		
C103SL	00D 963 9003 084	C,CERAMIC 100PF-K/500V	D00410106D050S		
C103SR	00D 963 9003 084	C,CERAMIC 100PF-K/500V	D00410106D050S		
C104	00D 963 9006 557	C,ELECT 220UF-M/6.3V	D040221081060S		
C104C	00D 963 9003 084	C,CERAMIC 100PF-K/500V	D00410106D050S		
C104FL	00D 963 9003 084	C,CERAMIC 100PF-K/500V	D00410106D050S		
C104FR	00D 963 9003 084	C,CERAMIC 100PF-K/500V	D00410106D050S		
C104SL	00D 963 9003 084	C,CERAMIC 100PF-K/500V	D00410106D050S		
C104SR	00D 963 9003 084	C,CERAMIC 100PF-K/500V	D00410106D050S		
C105	00D 963 9006 557	C,ELECT 220UF-M/6.3V	D040221081060S		
C105C	nsp	C,CERAMIC 0.022UF-Z/50V	D011223597160S		
C105FL	nsp	C,CERAMIC 0.022UF-Z/50V	D011223597160S		
C105FR	nsp	C,CERAMIC 0.022UF-Z/50V	D011223597160S		
C105SL	nsp	C,CERAMIC 0.022UF-Z/50V	D011223597160S		
C105SR	nsp	C,CERAMIC 0.022UF-Z/50V	D011223597160S		
C106	00D 963 0293 709	C,ELECT 100UF-M/10V	D040101082070S		
C107	nsp	C,CERAMIC 0.01UF-K/50V	D011103777160S		
C107C	00D 963 9003 097	C,FILM 0.1UF-K/250V	D02010407H080S		
C107FL	00D 963 9003 097	C,FILM 0.1UF-K/250V	D02010407H080S		
C107FR	00D 963 9003 097	C,FILM 0.1UF-K/250V	D02010407H080S		
C107SL	00D 963 9003 097	C,FILM 0.1UF-K/250V	D02010407H080S		
C107SR	00D 963 9003 097	C,FILM 0.1UF-K/250V	D02010407H080S		
C108	00D 963 0149 400	CAP.E.GENERIC 10000UF/63V	N211210388110S		
C108C	00D 963 9006 544	C,ELECT 22UF-M/25V	D040220084050S		
C108FL	00D 963 9006 544	C,ELECT 22UF-M/25V	D040220084050S		
C108FR	00D 963 9006 544	C,ELECT 22UF-M/25V	D040220084050S		
C108SL	00D 963 9006 544	C,ELECT 22UF-M/25V	D040220084050S		

Ref. No.	Part No.	Part Name	Remarks	Q'ty	New
C108SR C109	00D 963 9006 544 00D 963 0149 400	C,ELECT 22UF-M/25V CAP.E.GENERIC 10000UF/63V	D040220084050S N211210388110S		
C109C C109FL C109FR C109SL C109SR	00D 963 0234 205 00D 963 0234 205 00D 963 0234 205 00D 963 0234 205 00D 963 0234 205	C,ELECT 10UF-M/50V C,ELECT 10UF-M/50V C,ELECT 10UF-M/50V C,ELECT 10UF-M/50V C,ELECT 10UF-M/50V	D040100087070S D040100087070S D040100087070S D040100087070S D040100087070S		
C110 C110C C110FL C110FR C110SL	00D 963 9003 097 00D 963 0338 208 00D 963 0338 208 00D 963 0338 208 00D 963 0338 208	C,FILM 0.1UF-K/250V C,CERAMIC 470PF-K/500V C,CERAMIC 470PF-K/500V C,CERAMIC 470PF-K/500V C,CERAMIC 470PF-K/500V	D02010407H080S D00447127D050S D00447127D050S D00447127D050S D00447127D050S		
C110SR C111 C111C C111FL C111FR	00D 963 0338 208 00D 963 9003 097 00D 963 0367 101 00D 963 0367 101 00D 963 0367 101	C,CERAMIC 470PF-K/500V C,FILM 0.1UF-K/250V C,CERAMIC 220PF-J/500V C,CERAMIC 220PF-J/500V C,CERAMIC 220PF-J/500V	D00447127D050S D02010407H080S D00422106D05CS D00422106D05CS D00422106D05CS		
C111SL C111SR C112 C112C C112FL	00D 963 0367 101 00D 963 0367 101 00D 963 9003 097 00D 963 9003 194 00D 963 9003 194	C,CERAMIC 220PF-J/500V C,CERAMIC 220PF-J/500V C,FILM 0.1UF-K/250V C,FILM 0.0022UF-J/100V C,FILM 0.0022UF-J/100V	D00422106D05CS D00422106D05CS D02010407H080S D02022206C060S D02022206C060S		
C112FR C112SL C112SR C113C C113FL	00D 963 9003 194 00D 963 9003 194 00D 963 9003 194 00D 963 0293 709 00D 960 9010 133	C,FILM 0.0022UF-J/100V C,FILM 0.0022UF-J/100V C,FILM 0.0022UF-J/100V C,ELECT 100UF-M/10V C,ELECT 220UF-M/35V	D02022206C060S D02022206C060S D02022206C060S D040101082070S D040221085060S		
C113FR C113SL C113SR C114 C114C	00D 960 9010 133 00D 963 0293 709 00D 963 0293 709 00D 963 9003 097 00D 963 0216 100	C,ELECT 220UF-M/35V C,ELECT 100UF-M/10V C,ELECT 100UF-M/10V C,FILM 0.1UF-K/250V C,CERAMIC 33PF-J/500V	D040221085060S D040101082070S D040101082070S D02010407H080S D00033006D050S		
C114FL C114FR C114SL C114SR C115	00D 963 0216 100 00D 963 0216 100 00D 963 0216 100 00D 963 0216 100 00D 963 9003 097	C,CERAMIC 33PF-J/500V C,CERAMIC 33PF-J/500V C,CERAMIC 33PF-J/500V C,CERAMIC 33PF-J/500V C,FILM 0.1UF-K/250V	D00033006D050S D00033006D050S D00033006D050S D00033006D050S D02010407H080S		
C115SW C117-120 C141SW1 C142SW1 C155	00D 963 9006 544 nsp 00D 963 0234 205 nsp 00D 963 0244 606	C,ELECT 22UF-M/25V C,CERAMIC 0.1UF-K/50V C,ELECT 10UF-M/50V C,CERAMIC 100PF-J/50V C,ELECT 0.1UF-M/50V (Pb Free)	D040220084050S D011104577160S D040100087070S D010101167160S D040R10087080S		
C161 C162,163 C164-167 C168-172 C177	00D 963 0234 205 nsp nsp 00D 963 0244 606 nsp	C,ELECT 10UF-M/50V C,CERAMIC 0.01UF-K/50V C,CERAMIC 100PF-J/50V C,ELECT 0.1UF-M/50V (Pb Free) C,CERAMIC 0.01UF-K/50V	D040100087070S D011103777160S D010101167160S D040R10087080S D011103777160S		
C178,179 C180,181 C182 C183 C190	00D 960 9010 010 nsp 00D 963 0324 005 00D 963 0293 602 00D 960 9010 010	C,ELECT 4.7UF-M/50V C,CERAMIC 0.01UF-K/50V C,ELECT 100UF-M/100V C,ELECT 1UF-M/50V (Pb Free) C,ELECT 4.7UF-M/50V	D0404R7087250S D011103777160S D04010108C240S D040010087150S D0404R7087250S		
C221L C221R C222L	nsp nsp 00D 960 9010 010	C,CERAMIC 100PF-J/50V C,CERAMIC 100PF-J/50V C,ELECT 4.7UF-M/50V	D010101167160S D010101167160S D0404R7087250S		

Ref. No.	Part No.	Part Name	Remarks	Q'ty	New
C222R	00D 960 9010 010	C,ELECT 4.7UF-M/50V	D0404R7087250S		
C224L	00D 960 9010 010	C,ELECT 4.7UF-M/50V	D0404R7087250S		
C224R	00D 960 9010 010	C,ELECT 4.7UF-M/50V	D0404R7087250S		
C231	00D 963 0244 606	C,ELECT 0.1UF-M/50V (Pb Free)	D040R10087080S		
C232	nsp	C,CERAMIC 0.01UF-K/50V	D011103777160S		
C233	00D 963 0293 602	C,ELECT 1UF-M/50V (Pb Free)	D040010087150S		
C234	nsp	C,CERAMIC 100PF-J/50V	D010101167160S		
C235,236	00D 960 9008 653	C,FILM 0.012UF-J/100V	D02012306C060S		
C237	00D 963 9005 862	C,ELECT 47UF-M/16V	D040470083080S		
OTHERS PARTS GROUP					
BKT101	nsp	SHIELD PLATE GND	3070045526010S		
CN101	nsp	CN,WIRE 110MM/10P	L000111100070S		
CN103	nsp	CN,WIRE 120MM/7P	L000121070060S		
CN201	nsp	CN,WIRE 70MM/6P	L000700060110S		
CN511	nsp	CN,WIRE 60MM/9P	L000600090020S		
CN704	nsp	CN,WIRE 15P	L000600150030S		
CP103	nsp	CN.WAFER 3P	L102526700300S		
CP104	nsp	CN.WAFER 3CKT	L108353280360S		
CP105,106	nsp	CN.WAFER 5P	L101100040510S		
CP107	nsp	CN.WAFER 3P	L102526700300S		
CP108	nsp	CN.WAFER 17P	L101100041710S		
CP541	nsp	CN.WAFER 3P	L101220030000S		
GND101	nsp	TERMINAL EARTH	3790040886000S		
JACK221	90M -YT 0046 40R	TER,RCA 2PIN	G601207AE020YS		
JACK222	00D 963 0146 005	TER,RCA 1PIN	G600107A0000YS		
JACK231,232	00D 963 0244 703	JACK,D3.5 EARPHONE	G40130802000YS		
L101C	00D 963 0049 005	COIL INDUCTOR 0.5UH	D330R50000000S		
L101FL	00D 963 0049 005	COIL INDUCTOR 0.5UH	D330R50000000S		
L101FR	00D 963 0049 005	COIL INDUCTOR 0.5UH	D330R50000000S		
L101SL	00D 963 0049 005	COIL INDUCTOR 0.5UH	D330R50000000S		
L101SR	00D 963 0049 005	COIL INDUCTOR 0.5UH	D330R50000000S		
L231	nsp	BEAD,COIL 3580	7610010030000S		
RLY541	00D 963 0218 506	RELAY BC3-24 24V 2A	G680240202040S		
TP101-105	nsp	CN.WAFER 3P	L101530140310S		
JP108	00D 963 0223 009	R,THICK 0-J,1/16W	C20000006M160S		
JP347	nsp	C,CERAMIC 0.1UF-K/50V	D011104577160S		
JP352	00D 963 0223 009	R,CHIP THICK 0-J,1/16W	C20000006M160S		

FRONT P.W.B. UNIT ASS'Y

	Ref. No.	Part No.	Part Name	Remarks	Q'ty	New
SEMICONDUCTORS GROUP						
	IC301	00D 963 0074 504	IC BU2090F-E2	J044209000010S		
	IC302	00D 262 3758 009	LC87F6D64A-QFP-E	J127876160010S		
▲	IC303	00D 960 0195 808	IC ICP-N15	J120001500030S		
	IC305	00D 963 0024 004	IC NJM2068M	J121206800020S		
	Q301-303	00D 963 0120 704	TR KRA102S	J520010200210S		
	Q304	00D 963 0121 606	TR KRC107S	J522107S00210S		
	Q305	00D 963 0102 803	TR 2SA933S	J5000933S0050S		
	Q306	00D 963 0120 801	TR KRC102S	J522010200210S		
	Q307-309	00D 963 0120 704	TR KRA102S	J520010200210S		
	Q310,311	00D 963 0120 801	TR KRC102S	J522010200210S		
	Q312	00D 960 0133 103	TR KSA916Y	J5000916Y0050S		
	Q542-546	00D 963 0121 208	TR KRC107M	J6020107M0010S		
	D301,302	00D 963 0020 309	D,SWITCHING 1SS133T	K000013300520S		
	D303	00D 963 0355 401	D,SWITCHING KDS4148U	K005041480030S		
	D304	00D 963 0020 309	D,SWITCHING 1SS133T	K000013300520S		
	D305-311	00D 963 0355 401	D,SWITCHING KDS4148U	K005041480030S		
	D312	00D 963 0328 409	D,SWITCHING 1N4007	K000400700010S		
	D313-316	00D 963 0355 401	D,SWITCHING KDS4148U	K005041480030S		
	D542	00D 963 0020 309	D,SWITCHING 1SS133T	K000013300520S		
	D543-545	00D 963 0355 401	D,SWITCHING KDS4148U	K005041480030S		
	D546	00D 963 0020 309	D,SWITCHING 1SS133T	K000013300520S		
	ZD302-308	00D 960 0095 500	D,ZENER MTZJ5.1B	K06005R144520S		
	ZD309	00D 960 0095 801	D,ZENER MTZJ6.8B	K06006R844520S		
	ZD310,311	00D 963 0046 202	D,ZENER MTZJ18B	K06018R044520S		
	ZD312,313	00D 960 0095 500	D,ZENER MTZJ5.1B	K06005R144520S		
	LED302-309	00D 960 0197 204	LED PI5-RD/HL50RDRF4T	K500052015010S		
	LED310	00D 963 0366 108	LED BL-BEG204-L 5PI	K500052004010S		
	LED311	00D 963 0148 605	LED SML1216W 5PI	K500052600030S		
	FL301	00D 963 0257 305	DISPLAY,FLT HNA-16SM13T	K530161300020S		
RESISTORS GROUP						
	R372	00D 963 0215 907	R,METAL FILM 4.7-J,1W	C0604R7065050S		
	R378,379	00D 960 9009 270	R,METAL FILM 470-J,2W	C060047166520S		
	R501	00D 960 9003 700	R,METAL FILM 10-J,1/4W	C060010063050S		
	RP1-38	00D 963 0353 005	R,CHIP THICK 56K-J,1/16W	C20005636M160S		
	RG1-16	00D 963 0353 005	R,CHIP THICK 56K-J,1/16W	C20005636M160S		
CAPACITORS GROUP						
	C301,302	nsp	C,CERAMIC 100PF-J/50V	D010101167160S		
	C303	nsp	C,CERAMIC 0.022UF-K/25V	D011223777160S		
	C304	00D 963 9005 862	C,ELECT 47UF-M/16V	D040470083080S		
	C305	nsp	C,CERAMIC 100PF-J/50V	D010101167160S		
	C306	nsp	C,CERAMIC 0.047UF-Z/50V	D011473597160S		
	C307	00D 963 9005 862	C,ELECT 47UF-M/16V	D040470083080S		
	C308	nsp	C,CERAMIC 0.01UF-K/50V	D011103777160S		

Ref. No.	Part No.	Part Name	Remarks	Q'ty	New
C309,310	00D 963 0293 602	C,ELECT 1UF-M/50V (Pb Free)	D040010087150S		
C311	00D 963 0233 303	C,CERAMIC 0.01UF-M/16V	D005103773530S		
C312	00D 963 9005 862	C,ELECT 47UF-M/16V	D040470083080S		
C315	nsp	C,CERAMIC 150PF-J/50V	D010151167160S		
C316,317	nsp	C,CERAMIC 330PF-J/50V	D010331167160S		
C318	nsp	C,CERAMIC 100PF-J/50V	D010101167160S		
C319,320	nsp	C,CERAMIC 0.01UF-K/50V	D011103777160S		
C321,322	00D 963 0233 303	C,CERAMIC 0.01UF-M/16V	D005103773530S		
C323-325	00D 963 0293 602	C,ELECT 1UF-M/50V (Pb Free)	D040010087150S		
C326	00D 963 9005 862	C,ELECT 47UF-M/16V	D040470083080S		
C327,328	nsp	C,CERAMIC 0.1UF-K/50V	D011104577160S		
C329	nsp	C,FILM 0.1UF-J/100V	D02010406C060S		
C330	00D 963 0021 900	C,FILM 0.047UF-J/100V	D02047306C060S		
C331	00D 963 0234 205	C,ELECT 10UF-M/50V	D040100087070S		
C332	nsp	C,CERAMIC 150PF-J/50V	D010151167160S		
C333	00D 963 0293 602	C,ELECT 1UF-M/50V (Pb Free)	D040010087150S		
C334	00D 963 0021 900	C,FILM 0.047UF-J/100V	D02047306C060S		
C335	nsp	C,CERAMIC 0.1UF-K/50V	D011104577160S		
C336	nsp	C,CERAMIC 100PF-J/50V	D010101167160S		
C337	00D 963 0293 602	C,ELECT 1UF-M/50V (Pb Free)	D040010087150S		
C338	nsp	C,CERAMIC 0.01UF-K/50V	D011103777160S		
C339	nsp	C,CERAMIC 100PF-J/50V	D010101167160S		
C340	nsp	C,CERAMIC 1000PF-K/50V	D011102777160S		
C341,342	nsp	C,CERAMIC 100PF-J/50V	D010101167160S		
C343	00D 963 0020 202	C,CERAMIC 0.1UF-Z/50V	D005104597530S		
C344,345	00D 963 0233 206	C,CERAMIC 0.001UF-K/50V	D005102177530S		
C346-349	nsp	C,CERAMIC 0.01UF-K/50V	D011103777160S		
C350	00D 963 0021 900	C,FILM 0.047UF-J/100V	D02047306C060S		
C351	00D 963 0293 602	C,ELECT 1UF-M/50V (Pb Free)	D040010087150S		
C352	00D 963 0234 205	C,ELECT 10UF-M/50V	D040100087070S		
C353,354	00D 963 0293 602	C,ELECT 1UF-M/50V (Pb Free)	D040010087150S		
C355	nsp	C,ELECT 470UF-M/63V	D040471088010S		
C356	00D 963 9003 097	C,FILM 0.1UF-K/250V	D02010407H080S		
C357,358	nsp	C,CERAMIC 0.047UF-Z/50V	D011473597160S		
C541	nsp	C,CERAMIC 2200PF-K/50V	D011222777160S		
C541FL	00D 963 0024 703	C,FILM 0.01UF-J/100V	D02010306C060S		
C542	nsp	C,CERAMIC 2200PF-K/50V	D011222777160S		
C542FR	00D 963 0024 703	C,FILM 0.01UF-J/100V	D02010306C060S		
C543	nsp	C,CERAMIC 2200PF-K/50V	D011222777160S		
C543FL	00D 963 0024 703	C,FILM 0.01UF-J/100V	D02010306C060S		
C544	nsp	C,CERAMIC 2200PF-K/50V	D011222777160S		
C544FR	00D 963 0024 703	C,FILM 0.01UF-J/100V	D02010306C060S		
C545	nsp	C,CERAMIC 2200PF-K/50V	D011222777160S		
C545C	00D 963 0024 703	C,FILM 0.01UF-J/100V	D02010306C060S		
C546	nsp	C,CERAMIC 2200PF-K/50V	D011222777160S		
C546SL	00D 963 0024 703	C,FILM 0.01UF-J/100V	D02010306C060S		
C547	nsp	C,CERAMIC 2200PF-K/50V	D011222777160S		
C547SR	00D 963 0024 703	C,FILM 0.01UF-J/100V	D02010306C060S		
C548	nsp	C,CERAMIC 2200PF-K/50V	D011222777160S		
C548SBL	00D 963 0024 703	C,FILM 0.01UF-J/100V	D02010306C060S		
C549	nsp	C,CERAMIC 2200PF-K/50V	D011222777160S		
C549SBR	00D 963 0024 703	C,FILM 0.01UF-J/100V	D02010306C060S		
OTHERS PARTS GROUP					
BD301-307	nsp	COIL,BEAD MB-160808	D340160800060S		

Ref. No.	Part No.	Part Name	Remarks	Q'ty	New
CN102	nsp	CN,WIRE 270,170MM/4P	L000271040040S		
CN301	nsp	CN,WIRE 2P	L000401020050S		
CN302A	nsp	CN,WIRE 5P	L000450050010S		
CN303A	nsp	CN,WIRE 8P	L000450080010S		
CN304	nsp	CN,WIRE 3P	L000500030050S		
CN305	nsp	CN,WIRE 10P	L000700100030S		
CN541	nsp	CN,WIRE 3P	L000251030080S		
CP101	nsp	CN.WAFER 10P	L102526701000S		
CP103	nsp	CN.WAFER 7P	L101220070000S		
CP105	nsp	CN.WAFER 4P ANGLE	L102526800400S		
CP301B	nsp	CN.FPC 35P	L131103500010S		
CP302	nsp	CN.WAFER 3P ANGLE	L102526803010S		
CP304	nsp	CN.WAFER 3P	L101220030000S		
CP305	nsp	CN.WAFER 10P	L101220100010S		
CP306	nsp	CN.WAFER 3P	L101220030010S		
G301	nsp	RING,TER WIRE 120MM/1P	8410121010060S		
G302	nsp	RING,TER WIRE 120MM/1P	8410121010110S		
G304	nsp	RING,TER WIRE 80MM/2P	8410800020040S		
JACK301	00D 963 0367 802	JACK,D3.5 EARPHONE	G401PJ354H40YS		
JACK304	00D 963 0146 403	TER,RCA 3PIN	G606308HG110YS		
JACK501,502	00D 963 0146 607	TER,BOARD SCREW 8P	G614801A0200YS		
JACK503	00D 963 0158 608	TER,BOARD SCREW 2P	G611201A0200YS		
JK302	00D 963 0294 708	JACK,D6.5 PHONE	G402PJ612AG0YS		
L302	nsp	COIL INDUCTOR 10UH	D330100700520S		
L303	nsp	COIL INDUCTOR 100UH	D330101001020S		
RLY541	00D 963 0366 201	RELAY G5PA-28-MC 24V 5A	G680240502030S		
RLY543-546	00D 963 0366 201	RELAY G5PA-28-MC 24V 5A	G680240502030S		
RMC301	00D 963 0217 808	MODULE,REMOCON NJL34H380A	E940343800010S		
△ SW301	00D 963 0145 802	SW,PUSH SDDL-005-S(C-UL)	G000122006060S		
SW301A	00D 963 0095 305	SW,TACT SKHV10910D01	G180040500010S		
SW301C	00D 963 0095 305	SW,TACT SKHV10910D01	G180040500010S		
SW302A	00D 963 0095 305	SW,TACT SKHV10910D01	G180040500010S		
SW302B	00D 963 0095 305	SW,TACT SKHV10910D01	G180040500010S		
SW302C	00D 963 0095 305	SW,TACT SKHV10910D01	G180040500010S		
SW303A	00D 963 0095 305	SW,TACT SKHV10910D01	G180040500010S		
SW303B	00D 963 0095 305	SW,TACT SKHV10910D01	G180040500010S		
SW303C	00D 963 0095 305	SW,TACT SKHV10910D01	G180040500010S		
SW304A	00D 963 0095 305	SW,TACT SKHV10910D01	G180040500010S		
SW304B	00D 963 0095 305	SW,TACT SKHV10910D01	G180040500010S		
SW304C	00D 963 0095 305	SW,TACT SKHV10910D01	G180040500010S		
SW305A	00D 963 0095 305	SW,TACT SKHV10910D01	G180040500010S		
SW305B	00D 963 0095 305	SW,TACT SKHV10910D01	G180040500010S		
SW305C	00D 963 0095 305	SW,TACT SKHV10910D01	G180040500010S		
SW306A	00D 963 0095 305	SW,TACT SKHV10910D01	G180040500010S		
SW306B	00D 963 0095 305	SW,TACT SKHV10910D01	G180040500010S		
SW306C	00D 963 0095 305	SW,TACT SKHV10910D01	G180040500010S		
SW307A	00D 963 0095 305	SW,TACT SKHV10910D01	G180040500010S		

Ref. No.	Part No.	Part Name	Remarks	Q'ty	New
SW307B	00D 963 0095 305	SW,TACT SKHV10910D01	G180040500010S		
SW307C	00D 963 0095 305	SW,TACT SKHV10910D01	G180040500010S		
SW308A	00D 963 0095 305	SW,TACT SKHV10910D01	G180040500010S		
SW308B	00D 963 0095 305	SW,TACT SKHV10910D01	G180040500010S		
SW308C	00D 963 0095 305	SW,TACT SKHV10910D01	G180040500010S		
SW309A	00D 963 0095 305	SW,TACT SKHV10910D01	G180040500010S		
SW310	00D 963 0095 305	SW,TACT SKHV10910D01	G180040500010S		
VEC203	00D 963 0300 401	SW,ENCODER EC11B20C2	G121112020000S		
VEC301	00D 963 0095 208	SW,ENCODER EC16B24SO	G121162400070S		
VEC303	00D 963 0095 208	SW,ENCODER EC16B24SO	G121162400070S		
	nsp	HOLDER FLT	4320200026000S		

INPUT P.W.B. UNIT ASS'Y

Ref. No.	Part No.	Part Name	Remarks	Q'ty	New
SEMICONDUCTORS GROUP					
IC700	00D 963 0366 304	IC R2A15215FP		J084152150010S	
IC702	00D 963 0024 004	IC NJM2068M		J121206800020S	
IC705-718	00D 963 0024 004	IC NJM2068M		J121206800020S	
Q700,701	00D 960 0196 807	TR 2SK117Y		J5441170Y0050S	
Q702	00D 963 0120 704	TR KRA102S		J520010200210S	
Q703	00D 960 0285 006	TR KRC104S		J522104S00210S	
D700,701	00D 963 0355 401	D,SWITCHING KDS4148U		K005041480030S	
ZD700,701	00D 960 0222 603	D,ZENER MTZJ7.5A		K06007R544530S	
RESISTORS GROUP					
R706-709	00D 963 9005 639	R,METAL FILM 100-J,1W		C060010165060S	
R791VC	nsp	R,METAL FILM 120-J,1W		C060012165060S	
R791VE	nsp	R,METAL FILM 120-J,1W		C060012165060S	
CAPACITORS GROUP					
C700	00D 963 0234 205	C,ELECT 10UF-M/50V		D040100087070S	
C702SW	00D 960 9010 010	C,ELECT 4.7UF-M/50V		D0404R7087250S	
C703C	nsp	C,CERAMIC 0.047UF-Z/50V		D011473597160S	
C703SW	nsp	C,CERAMIC 0.047UF-Z/50V		D011473597160S	
C704,705	00D 963 9005 875	C,ELECT 47UF-M/25V		D040470084070S	
C706FL	00D 963 9005 875	C,ELECT 47UF-M/25V		D040470084070S	
C706FR	00D 963 9005 875	C,ELECT 47UF-M/25V		D040470084070S	
C707FL	00D 963 0234 205	C,ELECT 10UF-M/50V		D040100087070S	
C707FR	00D 963 0234 205	C,ELECT 10UF-M/50V		D040100087070S	
C707SW	00D 963 0234 205	C,ELECT 10UF-M/50V		D040100087070S	
C708FL	nsp	C,CERAMIC 33PF-J/50V		D010330167160S	
C708FR	nsp	C,CERAMIC 33PF-J/50V		D010330167160S	
C708SW	nsp	C,CERAMIC 47PF-J/50V		D010470167160S	
C709FL	nsp	C,CERAMIC 0.047UF-Z/50V		D011473597160S	
C709FR	nsp	C,CERAMIC 0.047UF-Z/50V		D011473597160S	
C709SW	nsp	C,CERAMIC 0.047UF-Z/50V		D011473597160S	
C710	00D 963 0223 009	R,THICK 0-J,1/16W		C20000006M160S	
C710FL	nsp	C,CERAMIC 100PF-J/50V		D010101167160S	
C710FR	nsp	C,CERAMIC 100PF-J/50V		D010101167160S	
C710SW	nsp	C,CERAMIC 100PF-J/50V		D010101167160S	
C711	00D 963 0223 009	R,THICK 0-J,1/16W		C20000006M160S	
C711FL	nsp	C,CERAMIC 0.047UF-Z/50V		D011473597160S	
C711FR	nsp	C,CERAMIC 0.047UF-Z/50V		D011473597160S	
C711SW	nsp	C,CERAMIC 0.047UF-Z/50V		D011473597160S	
C712	00D 963 0293 602	C,ELECT 1UF-M/50V (Pb Free)		D040010087150S	
C713-715	00D 963 0223 009	R,THICK 0-J,1/16W		C20000006M160S	
C716-727	00D 960 9009 814	C,CERAMIC 330PF-J/50V		D010331167160S	
C728-731	nsp	C,CERAMIC 20PF-J/50V		D010200167160S	
C732-739	00D 960 9009 814	C,CERAMIC 330PF-J/50V		D010331167160S	
C740-751	00D 963 0234 205	C,ELECT 10UF-M/50V		D040100087070S	
C751A	00D 963 0234 205	C,ELECT 10UF-M/50V		D040100087070S	
C751B	00D 963 0234 205	C,ELECT 10UF-M/50V		D040100087070S	
C751C	00D 963 0234 205	C,ELECT 10UF-M/50V		D040100087070S	
C751D	00D 963 0234 205	C,ELECT 10UF-M/50V		D040100087070S	

Ref. No.	Part No.	Part Name	Remarks	Q'ty	New
C751E	00D 963 0234 205	C,ELECT 10UF-M/50V	D040100087070S		
C751F	00D 963 0234 205	C,ELECT 10UF-M/50V	D040100087070S		
C751G	00D 963 0234 205	C,ELECT 10UF-M/50V	D040100087070S		
C751H	00D 963 0234 205	C,ELECT 10UF-M/50V	D040100087070S		
C751J	00D 963 0234 205	C,ELECT 10UF-M/50V	D040100087070S		
C751K	00D 963 0234 205	C,ELECT 10UF-M/50V	D040100087070S		
C751L	00D 963 0234 205	C,ELECT 10UF-M/50V	D040100087070S		
C751M	00D 963 0234 205	C,ELECT 10UF-M/50V	D040100087070S		
C751N	00D 963 0234 205	C,ELECT 10UF-M/50V	D040100087070S		
C751P	00D 963 0234 205	C,ELECT 10UF-M/50V	D040100087070S		
C751Q	00D 963 0234 205	C,ELECT 10UF-M/50V	D040100087070S		
C751R	00D 963 0234 205	C,ELECT 10UF-M/50V	D040100087070S		
C751S	00D 963 0234 205	C,ELECT 10UF-M/50V	D040100087070S		
C751T	00D 963 0234 205	C,ELECT 10UF-M/50V	D040100087070S		
C751U	00D 963 0234 205	C,ELECT 10UF-M/50V	D040100087070S		
C751V	00D 963 0234 205	C,ELECT 10UF-M/50V	D040100087070S		
C752	00D 963 0234 205	C,ELECT 10UF-M/50V	D040100087070S		
C752A	nsp	C,CERAMIC 0.047UF-Z/50V	D011473597160S		
C752B	nsp	C,CERAMIC 0.047UF-Z/50V	D011473597160S		
C752C	nsp	C,CERAMIC 0.047UF-Z/50V	D011473597160S		
C752D	nsp	C,CERAMIC 0.047UF-Z/50V	D011473597160S		
C752E	nsp	C,CERAMIC 0.047UF-Z/50V	D011473597160S		
C752F	nsp	C,CERAMIC 0.047UF-Z/50V	D011473597160S		
C752G	nsp	C,CERAMIC 0.047UF-Z/50V	D011473597160S		
C752H	nsp	C,CERAMIC 0.047UF-Z/50V	D011473597160S		
C752J	nsp	C,CERAMIC 0.047UF-Z/50V	D011473597160S		
C752K	nsp	C,CERAMIC 0.047UF-Z/50V	D011473597160S		
C752L	nsp	C,CERAMIC 0.047UF-Z/50V	D011473597160S		
C752M	nsp	C,CERAMIC 0.047UF-Z/50V	D011473597160S		
C752N	nsp	C,CERAMIC 0.047UF-Z/50V	D011473597160S		
C752P	nsp	C,CERAMIC 0.047UF-Z/50V	D011473597160S		
C752Q	nsp	C,CERAMIC 0.047UF-Z/50V	D011473597160S		
C752R	nsp	C,CERAMIC 0.047UF-Z/50V	D011473597160S		
C752S	nsp	C,CERAMIC 0.047UF-Z/50V	D011473597160S		
C752T	nsp	C,CERAMIC 0.047UF-Z/50V	D011473597160S		
C752U	nsp	C,CERAMIC 0.047UF-Z/50V	D011473597160S		
C752V	nsp	C,CERAMIC 0.047UF-Z/50V	D011473597160S		
C752W	nsp	C,CERAMIC 0.1UF-Z/50V	D011104597160S		
C752X	nsp	C,CERAMIC 0.1UF-Z/50V	D011104597160S		
C753-771	00D 963 0234 205	C,ELECT 10UF-M/50V	D040100087070S		
C772,773	00D 963 0293 806	C,ELECT 100UF-M/10V (Pb Free)	D040101082090S		
C774	nsp	C,FILM 0.15UF-K/63V	D020154078060S		
C775	00D 963 0021 900	C,FILM 0.047UF-J/100V	D02047306C060S		
C776	00D 960 9008 640	C,FILM 0.022UF-J/100V	D02022306C060S		
C777	00D 963 0234 205	C,ELECT 10UF-M/50V	D040100087070S		
C778,779	nsp	C,CERAMIC 100PF-J/50V	D010101167160S		
C780	00D 963 0234 205	C,ELECT 10UF-M/50V	D040100087070S		
C781	00D 960 9008 640	C,FILM 0.022UF-J/100V	D02022306C060S		
C782	00D 963 0021 900	C,FILM 0.047UF-J/100V	D02047306C060S		
C783	nsp	C,FILM 0.15UF-K/63V	D020154078060S		
C784-790	00D 963 0293 806	C,ELECT 100UF-M/10V (Pb Free)	D040101082090S		
C791-793	00D 963 0234 205	C,ELECT 10UF-M/50V	D040100087070S		
C794	00D 963 0293 806	C,ELECT 100UF-M/10V (Pb Free)	D040101082090S		
C795-799	00D 963 0234 205	C,ELECT 10UF-M/50V	D040100087070S		
C800,801	00D 960 9010 832	C,ELECT 10UF-M/16V	D040100083050S		

Ref. No.	Part No.	Part Name	Remarks	Q'ty	New
OTHERS PARTS GROUP					
CLAMP501	nsp	CLAMP WIRE(SOLDER)		4330000120000S	
CN514	nsp	CN,WIRE 13P		L000181130010S	
CN702	nsp	CN.HOUSING 15P		L120912150010S	
CN703	nsp	CN.WAFER 8P		L101100030810S	
CN704	nsp	CN.WAFER 19P		L101100031910S	
CN706	nsp	CN,WIRE 8P		L000121080010S	
CP704	nsp	CN.WAFER 15P		L101220150000S	
JACK701	00D 963 0132 103	TER,RCA 4PIN		G602405B0400YS	
JACK702	00D9630387505	TER,RCA 4PIN		G602405B5500YS	
JACK703	00D 963 0132 103	TER,RCA 4PIN		G602405B0400YS	
JACK704,705	00D 963 0132 307	TER,RCA 6PIN		G603603B05000S	

POWER P.W.B. UNIT ASS'Y

Ref. No.	Part No.	Part Name	Remarks	Q'ty	New
SEMICONDUCTORS GROUP					
△	IC501	00D 963 0057 806	IC KIA78R05PI	J126780500370S	
	IC502	00D 960 0195 808	IC ICP-N15	J120001500030S	
	IC511	00D 963 0147 606	IC KIA78R09API	J126780900120S	
	IC512	00D 960 0159 501	IC KIA7805API	J126780500110S	
	IC513	00D 963 0327 507	IC KIA7905PI	J126790500070S	
	IC515	00D 960 0174 900	IC KIA7815API	J126781500000S	
	IC516	00D 963 0021 502	IC KIA7915PI	J126791500030S	
	Q501	00D 960 0196 409	TR 2SC1740SR	J5021740S0010S	
	Q502	00D 963 0121 208	TR KRC107M	J6020107M0010S	
	Q503	00D 960 0196 409	TR 2SC1740SR	J5021740S0010S	
	D501-503	00D 276 0401 905	D,SWITCHING 1SS133T	K000013300520S	
	D504-507	00D 963 0328 409	D,SWITCHING 1N4007	K000400700010S	
	D508,509	00D 276 0401 905	D,SWITCHING 1SS133T	K000013300520S	
	D511,512	00D 276 0401 905	D,SWITCHING 1SS133T	K000013300520S	
	D513-520	00D 963 0328 409	D,SWITCHING 1N4007	K000400700010S	
	D521,522	00D 276 0401 905	D,SWITCHING 1SS133T	K000013300520S	
	D523-526	00D 963 0328 409	D,SWITCHING 1N4007	K000400700010S	
	ZD501	00D 960 0095 500	D,ZENER MTZJ5.1B	K06005R144520S	
	ZD502	00D 963 0219 903	D,ZENER MTZJ16B	K06016R044520S	
RESISTORS GROUP					
	R506	00D 963 0244 305	R,METAL FILM 2.2M 0.5W	C060022564520S	
	R507	00D 963 0232 809	R,METAL FILM 10-J,1/4W	C060010063520S	
	R508,509	00D 963 0216 003	R,METAL FILM 0.22-J,1W	C060R22065050S	
	R516-519	00D 963 0216 003	R,METAL FILM 0.22-J,1W	C060R22065050S	
CAPACITORS GROUP					
	C501	00D 963 0234 205	C,ELECT 10UF-M/50V	D040100087070S	
	C502	00D 963 0217 002	C,ELECT 3300UF-M/16V	D040332083010S	
	C503	00D 963 0293 602	C,ELECT 1UF-M/50V (Pb Free)	D040010087150S	
	C504	00D 963 0323 802	C,CERAMIC AC(SAFETY) 0.0047UF 250VAC	D00847208H010S	
	C506	00D 963 0293 602	C,ELECT 1UF-M/50V (Pb Free)	D040010087150S	
	C514-516	00D 963 0293 602	C,ELECT 1UF-M/50V (Pb Free)	D040010087150S	
	C517	00D 963 0234 205	C,ELECT 10UF-M/50V	D040100087070S	
	C518	00D 963 0217 002	C,ELECT 3300UF-M/16V	D040332083010S	
	C519	00D 963 0324 704	C,ELECT 4700UF-M/16V	D040472083200S	
	C520	00D 963 0021 104	C,ELECT 6800UF-M/16V	D040682083000S	
	C521-523	00D 963 0021 900	C,FILM 0.047UF-J/100V	D02047306C060S	
	C526,527	00D 960 0186 202	C,ELECT 220UF-M/35V	D040221085050S	
	C528	00D 963 0324 908	C,ELECT 4700UF-M/35V	D040472085020S	
	C529	00D 963 0224 707	C,ELECT 2200UF-M/35V	D040222085020S	
	C530-532	00D 963 0021 900	C,FILM 0.047UF-J/100V	D02047306C060S	
OTHERS PARTS GROUP					
	BKT501	nsp	SHIELD PLATE GND	3070045526010S	
	CLAMP102,103	nsp	CLAMP WIRE(SOLDER)	4330000120000S	

Ref. No.	Part No.	Part Name	Remarks	Q'ty	New
CN505	nsp	CN.WAFER 7P	L101100030710S		
CN506	nsp	CN.WAFER 12P	L101100031210S		
CP501	nsp	CN.WAFER 2CKT,YEL	L108353280290S		
CP503	nsp	CN.WAFER 2CKT,RED	L108353280280S		
CP504	nsp	CN.WAFER ST2P	L108202000220S		
CP505	nsp	CN.WAFER 7P	L101100040710S		
CP506	nsp	CN.WAFER 12P	L101100041210S		
CP511	nsp	CN.WAFER 9P	L101220090000S		
CP512	nsp	CN.WAFER 4P ANGLE	L102526800400S		
CP513	nsp	CN.WAFER 3P ANGLE	L102526803010S		
CP514	nsp	CN.WAFER 13P	L101220130000S		
⚠ F501	00D 963 0236 106	FUSE T8A /250V	N751228001110S		
F501A	nsp	HOLDER,FUSE CLIP	G645000050010S		
F501B	nsp	HOLDER,FUSE CLIP	G645000050010S		
⚠ F503	00D 963 0236 106	FUSE T8A /250V	N751228001110S		
F503A	nsp	HOLDER,FUSE CLIP	G645000050010S		
F503B	nsp	HOLDER,FUSE CLIP	G645000050010S		
GND501		TERMINAL EARTH	3790040886000S		
RLY501	00D 963 0218 205	RELAY HL3-1A-9SH DC9V 1A	G680090102020S		
⚠ SUB501	00D 963 0387 602	STAND-BY TRANS	8200280150401S		
⚠	nsp	HEAT SINK	2120043538050S		
	nsp	SCREW,TAP TITE +2S 3*8 B-TYPE ZNW/BH	B020030081B10S		
	nsp	SHIELD PLATE GND	3070045526010S		
	00D 203 3976 002	SOCKET,POWER RECEPTA	G435204004010S		

2CH-AMP P.W.B. UNIT ASS'Y

Ref. No.	Part No.	Part Name	Remarks	Q'ty	New
SEMICONDUCTORS GROUP					
IC401D	00D 960 0159 501	IC KIA7805API	J126780500110S		
IC401H	00D9630388805	CN,WIRE 110MM/3P	L000111030040S		
IC402D	00D9630226608	IC KIA78R33PI	J12678R330010S		
IC402X	00D 963 0366 603	IC KIA1117PI50	J126111750050S		
IC403	00D 263 1223 005	PQ20RX11J00H	J126201100010S		
IC403D	00D 963 0366 706	IC KIA1117PI00	J126111700050S		
Q401SBL	00D 963 0044 204	TR 2SD2390-Y	J5032390Y0000S		
Q401SBR	00D 963 0044 204	TR 2SD2390-Y	J5032390Y0000S		
Q401X	00D 963 0120 801	TR KRC102S	J522010200210S		
Q402D	00D 960 0097 304	TR KRC102M	J6020102M0010S		
Q402SBL	00D 963 0044 107	TR 2SB1560-Y	J5011560Y0000S		
Q402SBR	00D 963 0044 107	TR 2SB1560-Y	J5011560Y0000S		
Q402X	00D 963 0120 801	TR KRC102S	J522010200210S		
Q403SBL	00D 963 0280 107	TR 2SC3964	J502396400000S		
Q403SBR	00D 963 0280 107	TR 2SC3964	J502396400000S		
Q404SBL	00D 960 0196 506	TR KSC1845F	J5021845F0000S		
Q404SBR	00D 960 0196 506	TR KSC1845F	J5021845F0000S		
Q405SBL	00D 273 0459 903	TR KTC2874B	J502287400010S		
Q405SBR	00D 273 0459 903	TR KTC2874B	J502287400010S		
Q406SBL	00D 960 0196 205	TR KSA992F	J5000992F0050S		
Q406SBR	00D 960 0196 205	TR KSA992F	J5000992F0050S		
Q407SBL	00D 960 0196 205	TR KSA992F	J5000992F0050S		
Q407SBR	00D 960 0196 205	TR KSA992F	J5000992F0050S		
Q408SBL	00D 960 0196 506	TR KSC1845F	J5021845F0000S		
Q408SBR	00D 960 0196 506	TR KSC1845F	J5021845F0000S		
Q409D	00D 960 0097 304	TR KRC102M	J6020102M0010S		
D401H	00D 963 0328 409	D,SWITCHING 1N4007	K000400700010S		
D401SBL	00D 963 0341 004	D,SWITCHING KDS4148U	K005041480030S		
D401SBR	00D 963 0341 004	D,SWITCHING KDS4148U	K005041480030S		
D401X	00D 963 0328 409	D,SWITCHING 1N4007	K000400700010S		
D402	00D 276 0401 905	D,SWITCHING 1SS133T	K000013300520S		
D402H	00D 963 0328 409	D,SWITCHING 1N4007	K000400700010S		
D402SBL	00D 963 0341 004	D,SWITCHING KDS4148U	K005041480030S		
D402SBR	00D 963 0341 004	D,SWITCHING KDS4148U	K005041480030S		
D402X	00D 963 0328 409	D,SWITCHING 1N4007	K000400700010S		
D403	00D 276 0401 905	D,SWITCHING 1SS133T	K000013300520S		
ZD401D	00D 960 0095 607	D,ZENER MTZJ5.6B	K06005R644520S		
ZD401SBL	00D 963 0367 008	D,ZENER 0.2W 3.3V UDZ	K06603R34P400S		
ZD401SBR	00D 963 0367 008	D,ZENER 0.2W 3.3V UDZ	K06603R34P400S		
ZD402SBL	00D 963 0367 008	D,ZENER 0.2W 3.3V UDZ	K06603R04P400S		
ZD402SBR	00D 963 0367 008	D,ZENER 0.2W 3.3V UDZ	K06603R04P400S		
RESISTORS GROUP					
R401D	00D 963 9006 269	R,FIXED 1WJ-0.22	N113135622820S		
R401H	00D 963 9006 269	R,FIXED 1WJ-0.22	N113135622820S		
R401X	00D 963 9006 269	R,FIXED 1WJ-0.22	N113135622820S		
R402D	00D 963 9006 269	R,FIXED 1WJ-0.22	N113135622820S		
R402H	00D 963 9006 269	R,FIXED 1WJ-0.22	N113135622820S		
R402X	00D 963 9006 269	R,FIXED 1WJ-0.22	N113135622820S		
R410SBL	00D 963 9005 642	R,METAL FILM 1.2K-J,1W	C060012265050S		

Ref. No.	Part No.	Part Name	Remarks	Q'ty	New
R410SBR	00D 963 9005 642	R,METAL FILM 1.2K-J,1W	C060012265050S		
R411SBL	00D 960 9010 719	R,METAL FILM 47-J,1W	C060047065060S		
R411SBR	00D 960 9010 719	R,METAL FILM 47-J,1W	C060047065060S		
R414SBL	00D 963 9006 285	R,FIXED 1WJ-5.6K	N113135656220S		
R414SBR	00D 963 9006 285	R,FIXED 1WJ-5.6K	N113135656220S		
R415SBL	00D 963 9006 285	R,FIXED 1WJ-5.6K	N113135656220S		
R415SBR	00D 963 9006 285	R,FIXED 1WJ-5.6K	N113135656220S		
R419SBL	00D 963 0215 907	R,METAL FILM 4.7-J,1W	C0604R7065050S		
R419SBR	00D 963 0215 907	R,METAL FILM 4.7-J,1W	C0604R7065050S		
R420SBL	00D 963 0215 907	R,METAL FILM 4.7-J,1W	C0604R7065050S		
R420SBR	00D 963 0215 907	R,METAL FILM 4.7-J,1W	C0604R7065050S		
R421SBL	00D 963 0345 903	R,FIXED 2WJ-0.47	N113136647820S		
R421SBR	00D 963 0345 903	R,FIXED 2WJ-0.47	N113136647820S		
R422SBL	00D 963 0345 903	R,FIXED 2WJ-0.47	N113136647820S		
R422SBR	00D 963 0345 903	R,FIXED 2WJ-0.47	N113136647820S		
R423SBL	00D 963 0345 903	R,FIXED 2WJ-0.47	N113136647820S		
R423SBR	00D 963 0345 903	R,FIXED 2WJ-0.47	N113136647820S		
R424SBL	00D 963 0345 903	R,FIXED 2WJ-0.47	N113136647820S		
R424SBR	00D 963 0345 903	R,FIXED 2WJ-0.47	N113136647820S		
R429SBL	00D 963 9006 256	R,FIXED 1WJ-10	N113135610020S		
R429SBR	00D 963 9006 256	R,FIXED 1WJ-10	N113135610020S		
R430SBL	00D 963 9006 256	R,FIXED 1WJ-10	N113135610020S		
R430SBR	00D 963 9006 256	R,FIXED 1WJ-10	N113135610020S		
VR401,402	00D 963 0366 407	VR,SEMI CARBON EVN-DCAA03B 1KB	C541102315000S		
CAPACITORS GROUP					
C401D	00D 963 0021 900	C,FILM 0.047UF-J/100V	D02047306C060S		
C401H	00D 963 0021 900	C,FILM 0.047UF-J/100V	D02047306C060S		
C401X	nsp	C,CERAMIC 0.1UF-K/50V	D011104577160S		
C401SBL	00D 963 9006 544	C,ELECT 22UF-M/25V	D040220084050S		
C401SBR	00D 963 9006 544	C,ELECT 22UF-M/25V	D040220084050S		
C402D	00D 963 0021 900	C,FILM 0.047UF-J/100V	D02047306C060S		
C402H	00D 963 0021 900	C,FILM 0.047UF-J/100V	D02047306C060S		
C402SBL	00D 963 0234 205	C,ELECT 10UF-M/50V	D040100087070S		
C402SBR	00D 963 0234 205	C,ELECT 10UF-M/50V	D040100087070S		
C402X	00D 963 9003 097	C,FILM 0.1UF-K/250V	D02010407H080S		
C403D	00D 963 0021 900	C,FILM 0.047UF-J/100V	D02047306C060S		
C403H	00D 963 0021 900	C,FILM 0.047UF-J/100V	D02047306C060S		
C403SBL	00D 963 0367 101	C,CERAMIC 220PF-J/500V	D00422106D05CS		
C403SBR	00D 963 0367 101	C,CERAMIC 220PF-J/500V	D00422106D05CS		
C403X	00D 960 0133 404	C,ELECT 1000UF 16V	D040103083020S		
C404D	00D 960 0133 404	C,ELECT 1000UF 16V	D040103083020S		
C404H	00D 963 0217 002	C,ELECT 3300UF-M/16V	D040332083010S		
C404SBL	00D 963 0338 208	C,CERAMIC 470PF-K/500V	D00447127D050S		
C404SBR	00D 963 0338 208	C,CERAMIC 470PF-K/500V	D00447127D050S		
C404X	00D 963 0276 409	C,ELECT 100UF-M/16V	D040101083090S		
C405D	00D 963 0338 402	C,ELECT 330UF-M/6.3V	D040331081050S		
C405SBL	00D 963 0216 100	C,CERAMIC 33PF-J/500V	D00033006D050S		
C405SBR	00D 963 0216 100	C,CERAMIC 33PF-J/500V	D00033006D050S		
C406D	nsp	C,CERAMIC 0.1UF-K/50V	D011104577160S		
C406SBL	00D 963 0293 709	C,ELECT 100UF-M/10V	D040101082070S		
C406SBR	00D 963 0293 709	C,ELECT 100UF-M/10V	D040101082070S		
C406X	nsp	C,CERAMIC 1000PF-K/50V	D011102777160S		
C407D	nsp	C,CERAMIC 1000PF-K/50V	D011102777160S		

Ref. No.	Part No.	Part Name	Remarks	Q'ty	New
C407SBL	00D 963 9003 194	C,FILM 0.0022UF-J/100V	D02022206C060S		
C407SBR	00D 963 9003 194	C,FILM 0.0022UF-J/100V	D02022206C060S		
C407X	00D 963 0293 709	C,ELECT 100UF-M/10V	D040101082070S		
C408D	00D 963 0338 402	C,ELECT 330UF-M/6.3V	D040331081050S		
C408SBL	00D 963 0234 506	C,ELECT 47UF-M/50V (Pb Free)	D040470087070S		
C408SBR	00D 963 0234 506	C,ELECT 47UF-M/50V (Pb Free)	D040470087070S		
C408X	00D 963 0293 709	C,ELECT 100UF-M/10V	D040101082070S		
C409D	nsp	C,CERAMIC 0.1UF-K/50V	D011104577160S		
C409SBL	00D 963 9003 084	C,CERAMIC 100PF-K/500V	D00410106D050S		
C409SBR	00D 963 9003 084	C,CERAMIC 100PF-K/500V	D00410106D050S		
C410D	00D 963 0338 402	C,ELECT 330UF-M/6.3V	D040331081050S		
C410SBL	00D 963 0234 205	C,ELECT 10UF-M/50V	D040100087070S		
C410SBR	00D 963 0234 205	C,ELECT 10UF-M/50V	D040100087070S		
C411D	nsp	C,CERAMIC 0.1UF-K/50V	D011104577160S		
C411SBL	00D 963 9003 084	C,CERAMIC 100PF-K/500V	D00410106D050S		
C411SBR	00D 963 9003 084	C,CERAMIC 100PF-K/500V	D00410106D050S		
C412D	nsp	C,CERAMIC 0.1UF-K/50V	D011104577160S		
C412SBL	nsp	C,CERAMIC 0.022UF-K/25V	D011223777160S		
C412SBR	nsp	C,CERAMIC 0.022UF-K/25V	D011223777160S		
C413D	00D 963 0024 907	C,ELECT 1000UF-M/6.3V	D040102081060S		
C413SBL	00D 963 9003 097	C,FILM 0.1UF-K/250V	D02010407H080S		
C413SBR	00D 963 9003 097	C,FILM 0.1UF-K/250V	D02010407H080S		
C443	nsp	C,CERAMIC 1000PF-K/50V	D011102777160S		
OTHERS PARTS GROUP					
CLAMP401	nsp	CLAMP WIRE(SOLDER)	4330000120000S		
CN203	nsp	CN,WIRE 160MM/3P	L000161030060S		
CN401A	nsp	CN,WIRE 5P	L000191050030S		
CN405	nsp	CN,WIRE 5P	L000321050020S		
CN705	nsp	CN,WIRE 150MM/3P	L000151030010S		
CN904	nsp	CN,WIRE 6P	L000141060030S		
CP102	nsp	CN.WAFER 3P	L102526700300S		
CP201	nsp	CN.WAFER 6P	L101220060000S		
CP402	nsp	CN.WAFER 3P	L102526700300S		
L401SBL	nsp	COIL INDUCTOR 0.5UH	D330R50000000S		
L401SBR	nsp	COIL INDUCTOR 0.5UH	D330R50000000S		
TP401,402	nsp	CN.WAFER 3P ANGLE	L101530150310S		
	00D 963 0328 409	D,SWITCHING 1N4007	K000400700010S		

CPU P.W.B. UNIT ASS'Y

Ref. No.	Part No.	Part Name	Remarks	Q'ty	New
SEMICONDUCTORS GROUP					
IC712-715	00D 963 0024 004	IC NJM2068M		J121206800020S	
IC804	963243000020D	IC,CPU MICRO PROCESS	M30626FHPFP	8952150800015	
IC806	00D 960 0100 301	IC KIA7812API		J126781200040S	
IC813	00D 963 0367 204	IC SN74HC151PWR		J040741510070S	
IC817	00D 963 0244 907	IC SN74LV14APWR		J040741400180S	
IC818	00D 963 0367 307	IC SN74AHCU04PWR		J040740400290S	
IC824	00D 963 0043 807	IC BA4510F-E2/SOP8		J121451000010S	
IC827	00D 963 0043 807	IC BA4510F-E2/SOP8		J121451000010S	
IC830	00D 262 2813 903	SN74AHCT08PW-EL2 +C		J040740800190S	
Q704C	00D 963 0044 301	TR KTC2875B(MB)	<div style="border: 1px solid black; border-radius: 15px; padding: 5px; width: fit-content;"> ファームウェアをアップデート するときは、SDI で最終バージョン を確認して下さい。 サービス基板はアップデートし て使用下さい。 When update Firmware, please confirm a last version in SDI. Use the service board after updating it. </div>	J5222875B0010S	
Q704FL	00D 963 0044 301	TR KTC2875B(MB)		J5222875B0010S	
Q704FR	00D 963 0044 301	TR KTC2875B(MB)		J5222875B0010S	
Q704SBL	00D 963 0044 301	TR KTC2875B(MB)		J5222875B0010S	
Q704SBR	00D 963 0044 301	TR KTC2875B(MB)		J5222875B0010S	
Q704SL	00D 963 0044 301	TR KTC2875B(MB)		J5222875B0010S	
Q704SR	00D 963 0044 301	TR KTC2875B(MB)		J5222875B0010S	
Q704SW	00D 963 0044 301	TR KTC2875B(MB)		J5222875B0010S	
Q801	00D 963 0120 704	TR KRA102S		J520010200210S	
Q802-805	00D 963 0044 301	TR KTC2875B(MB)		J5222875B0010S	
Q806	00D 963 0121 509	TR KTC3875S	J522038750210S		
Q807	00D 960 0285 006	TR KRC104S	J522104S00210S		
Q810D	00D 963 0245 100	D,SWITCHING KDS226ST1(C3)	K005022600020S		
Q811D	00D 963 0245 100	D,SWITCHING KDS226ST1(C3)	K005022600020S		
Q812D	00D 963 0120 801	TR KRC102S	J522010200210S		
Q813D	00D 963 0120 704	TR KRA102S	J520010200210S		
D801-804	00D 963 0355 401	D,SWITCHING KDS4148U	K005041480030S		
D805	00D 963 0328 409	D,SWITCHING 1N4007	K000400700010S		
D807	00D 963 0355 401	D,SWITCHING KDS4148U	K005041480030S		
D807D	00D 963 0355 401	D,SWITCHING KDS4148U	K005041480030S		
D808D	00D 963 0341 305	D,ESD IMSA-6802-01A	K067680200010S		
D809D	00D 963 0355 401	D,SWITCHING KDS4148U	K005041480030S		
D810D	00D 963 0341 305	D,ESD IMSA-6802-01A	K067680200010S		
D811D	00D 963 0341 305	D,ESD IMSA-6802-01A	K067680200010S		
ZD801	00D 963 0047 502	D,ZENER MTZJ3.3B	K06003R344520S		
RESISTORS GROUP					
R857	00D 960 9003 807	R,METAL 100-J,1/4W		C060010163050S	
CAPACITORS GROUP					
C751C	00D 963 0234 205	C,ELECT 10UF-M/50V		D040100087070S	
C751FL	00D 963 0234 205	C,ELECT 10UF-M/50V		D040100087070S	
C751FR	00D 963 0234 205	C,ELECT 10UF-M/50V		D040100087070S	
C751SBL	00D 963 0234 205	C,ELECT 10UF-M/50V		D040100087070S	
C751SBR	00D 963 0234 205	C,ELECT 10UF-M/50V		D040100087070S	
C751SL	00D 963 0234 205	C,ELECT 10UF-M/50V		D040100087070S	
C751SR	00D 963 0234 205	C,ELECT 10UF-M/50V		D040100087070S	
C751SW	00D 963 0234 205	C,ELECT 10UF-M/50V		D040100087070S	
C752C	00D 963 0350 503	C,CERAMIC 390PF-J/50V		D010391167160S	
C752FL	00D 963 0223 708	C,CERAMIC 270PF-J/50V		D010271167160S	

Ref. No.	Part No.	Part Name	Remarks	Q'ty	New
C752FR	00D 963 0223 708	C,CERAMIC 270PF-J/50V	D010271167160S		
C752SBL	00D 960 9009 814	C,CERAMIC 330PF-J/50V	D010331167160S		
C752SBR	00D 960 9009 814	C,CERAMIC 330PF-J/50V	D010331167160S		
C752SL	00D 960 9009 814	C,CERAMIC 330PF-J/50V	D010331167160S		
C752SR	00D 960 9009 814	C,CERAMIC 330PF-J/50V	D010331167160S		
C752SW	00D 963 0350 503	C,CERAMIC 390PF-J/50V	D010391167160S		
C753C	00D 963 0224 008	C,CERAMIC 470PF-J/50V	D010471167160S		
C753FL	00D 963 0223 902	C,CERAMIC 39PF-J/50V	D010390167160S		
C753FR	00D 963 0223 902	C,CERAMIC 39PF-J/50V	D010390167160S		
C753SBL	00D 963 0223 708	C,CERAMIC 270PF-J/50V	D010271167160S		
C753SBR	00D 963 0223 708	C,CERAMIC 270PF-J/50V	D010271167160S		
C753SL	00D 963 0223 708	C,CERAMIC 270PF-J/50V	D010271167160S		
C753SR	00D 963 0223 708	C,CERAMIC 270PF-J/50V	D010271167160S		
C753SW	00D 963 0224 008	C,CERAMIC 470PF-J/50V	D010471167160S		
C755C	nsp	C,CERAMIC 0.1UF-Z/50V	D011104597160S		
C755FL	nsp	C,CERAMIC 0.1UF-Z/50V	D011104597160S		
C755FR	nsp	C,CERAMIC 0.1UF-Z/50V	D011104597160S		
C755SBL	nsp	C,CERAMIC 0.1UF-Z/50V	D011104597160S		
C755SBR	nsp	C,CERAMIC 0.1UF-Z/50V	D011104597160S		
C755SL	nsp	C,CERAMIC 0.1UF-Z/50V	D011104597160S		
C755SR	nsp	C,CERAMIC 0.1UF-Z/50V	D011104597160S		
C755SW	nsp	C,CERAMIC 0.1UF-Z/50V	D011104597160S		
C756C	00D 963 9003 194	C,FILM 0.0022UF-J/100V	D02022206C060S		
C756FL	00D 963 9003 194	C,FILM 0.0022UF-J/100V	D02022206C060S		
C756FR	00D 963 9003 194	C,FILM 0.0022UF-J/100V	D02022206C060S		
C756SBL	00D 963 9003 194	C,FILM 0.0022UF-J/100V	D02022206C060S		
C756SBR	00D 963 9003 194	C,FILM 0.0022UF-J/100V	D02022206C060S		
C756SL	00D 963 9003 194	C,FILM 0.0022UF-J/100V	D02022206C060S		
C756SR	00D 963 9003 194	C,FILM 0.0022UF-J/100V	D02022206C060S		
C756SW	00D 963 9003 194	C,FILM 0.0022UF-J/100V	D02022206C060S		
C757C	nsp	C,CERAMIC 10UF-Z/10V	D011106592200S		
C757FL	nsp	C,CERAMIC 10UF-Z/10V	D011106592200S		
C757FR	nsp	C,CERAMIC 10UF-Z/10V	D011106592200S		
C757SBL	nsp	C,CERAMIC 10UF-Z/10V	D011106592200S		
C757SBR	nsp	C,CERAMIC 10UF-Z/10V	D011106592200S		
C757SL	nsp	C,CERAMIC 10UF-Z/10V	D011106592200S		
C757SR	nsp	C,CERAMIC 10UF-Z/10V	D011106592200S		
C757SW	nsp	C,CERAMIC 10UF-Z/10V	D011106592200S		
C803	nsp	C,CERAMIC 100PF-J/50V	D010101167160S		
C804,805	nsp	C,CERAMIC 0.1UF-Z/50V	D011104597160S		
C806	nsp	C,CERAMIC 0.01UF-K/50V	D011103777160S		
C807,808	nsp	C,CERAMIC 0.022UF-Z/50V	D011223597160S		
C809	00D 963 0293 709	C,ELECT 100UF-M/10V	D040101082070S		
C810	nsp	C,CERAMIC 0.1UF-Z/50V	D011104597160S		
C813	nsp	C,CERAMIC 0.1UF-Z/50V	D011104597160S		
C814-816	nsp	C,CERAMIC 0.01UF-K/50V	D011103777160S		
C818	00D 960 9010 010	C,ELECT 4.7UF-M/50V	D0404R7087250S		
C819	nsp	C,CERAMIC 0.01UF-K/50V	D011103777160S		
C824,825	00D 963 0234 205	C,ELECT 10UF-M/50V	D040100087070S		
C826-831	nsp	C,CERAMIC 100PF-J/50V	D010101167160S		
C836,837	nsp	C,CERAMIC 0.022UF-Z/50V	D011223597160S		
C865L	nsp	C,CERAMIC 120PF-J/50V	D010121167160S		
C865R	nsp	C,CERAMIC 120PF-J/50V	D010121167160S		
C871L	00D 963 0216 304	C,FILM 0.001UF-J/100V	D02010206C060S		
C871R	00D 963 0216 304	C,FILM 0.001UF-J/100V	D02010206C060S		
C916D	nsp	C,CERAMIC 0.1UF-Z/50V	D011104597160S		

Ref. No.	Part No.	Part Name	Remarks	Q'ty	New
C917D	nsp	C,CERAMIC 0.1UF-Z/50V	D011104597160S		
C918D	nsp	C,CERAMIC 0.1UF-Z/50V	D011104597160S		
C921D	nsp	C,CERAMIC 100PF-J/50V	D010101167160S		
C923D	nsp	C,CERAMIC 22PF-J/50V	D010220167160S		
C924D	nsp	C,CERAMIC 22PF-J/50V	D010220167160S		
C927D	00D 963 9005 862	C,ELECT 47UF-M/16V	D040470083080S		
C928D	00D 963 9005 862	C,ELECT 47UF-M/16V	D040470083080S		
C931D	nsp	C,CERAMIC 100PF-J/50V	D010101167160S		
C932D	nsp	C,CERAMIC 0.01UF-K/50V	D011103777160S		
C933D	nsp	C,CERAMIC 0.01UF-K/50V	D011103777160S		
C934D	nsp	C,CERAMIC 0.01UF-K/50V	D011103777160S		
C935D	00D 960 9010 010	C,ELECT 4.7UF-M/50V	D0404R7087250S		
C936D	00D 960 9010 010	C,ELECT 4.7UF-M/50V	D0404R7087250S		
C937D	nsp	C,CERAMIC 1000PF-K/50V	D011102777160S		
C938D	00D 960 9010 010	C,ELECT 4.7UF-M/50V	D0404R7087250S		
C939D	nsp	C,CERAMIC 0.01UF-K/50V	D011103777160S		
C940D	nsp	C,CERAMIC 0.01UF-K/50V	D011103777160S		
C941D	00D 963 0244 606	C,ELECT 0.1UF-M/50V (Pb Free)	D040R10087080S		
C950D	nsp	C,CERAMIC 0.1UF-Z/50V	D011104597160S		
C951D	nsp	C,CERAMIC 0.1UF-Z/50V	D011104597160S		
C952D	00D 963 0234 205	C,ELECT 10UF-M/50V	D040100087070S		
C953D	00D 963 0234 205	C,ELECT 10UF-M/50V	D040100087070S		
C954D	nsp	C,CERAMIC 0.1UF-Z/50V	D011104597160S		
C955D	nsp	C,CERAMIC 0.1UF-Z/50V	D011104597160S		
C956D	nsp	C,CERAMIC 22PF-J/50V	D010220167160S		
C957D	nsp	C,CERAMIC 0.1UF-Z/50V	D011104597160S		
C959D	nsp	C,CERAMIC 22PF-J/50V	D010220167160S		
BC801	00D 254 4666 005	CE04W0H105ZC(FG)	D041105090010S		
OTHERS PARTS GROUP					
BD802-809	nsp	COIL,BEAD MB-160808	D340160800060S		
BD809D	nsp	COIL,BEAD MB-160808	D340160800060S		
BD810-817	nsp	COIL,BEAD MB-160808	D340160800060S		
CN105,106	nsp	CN.WAFER 5P	L101100030510S		
CN108	00D 963 0085 302	CN.WAFER 17P	L101100031710S		
CP01	nsp	CN.WAFER 16P	L101100041610S		
CP301A	00D 963 0367 400	CN.FPC 35P	L131524923520S		
CP701	nsp	CN.WAFER 19P	L101100041910S		
CP702	nsp	CN.WAFER 15P	L100912150010S		
CP703	nsp	CN.WAFER 8P	L101100040810S		
CP801	00D 963 0149 303	CN.FPC 15P	L131111500010S		
CP802	nsp	CN.WAFER 16P	L100912160010S		
CP804	nsp	CN.WAFER 15P	L100912150010S		
CP805	nsp	CN.WAFER 08P	L100912080010S		
CP1001	nsp	CN.WAFER 8P	L101100040810S		
CP1002	nsp	CN.WAFER 9P	L101100040910S		
JACK801	00D 963 0217 905	TER,RCA 2PIN	G601206A0200YS		
JACK802	00D 963 0294 601	JACK,D3.5 EARPHONE	G40100350000YS		
L801D	nsp	COIL INDUCTOR 4.7UH	D3304R7000150S		
L802D	nsp	COIL INDUCTOR 4.7UH	D3304R7000150S		

Ref. No.	Part No.	Part Name	Remarks	Q'ty	New
L803D	nsp	COIL INDUCTOR 4.7UH	D3304R7000150S		
L805D	nsp	COIL INDUCTOR 4.7UH	D3304R7000150S		
L806D	nsp	COIL INDUCTOR 22UH	D330220010520S		
L807D	nsp	COIL INDUCTOR 22UH	D330220010520S		
TP803	nsp	CN.WAFER 8P	L101220080000S		
TP804	nsp	CN.WAFER 4P	L101220040000S		
X801	00D 963 0217 701	RESONATOR,CERAMIC ZTT12.00MT	E830120000060S		
OPT801D	00D 963 0237 503	MODULE JSR1165-C	E100116500040S		
OPT802D	00D 963 0237 503	MODULE JSR1165-C	E100116500040S		
	nsp	CN,WIRE 110MM/1P	L000111010010S		

HDMI P.W.B. UNIT ASS'Y

Ref. No.	Part No.	Part Name	Remarks	Q'ty	New
SEMICONDUCTORS GROUP					
IC01	nsp	SII9185CTU	00D2623721007		
IC03	nsp	IC SE1117-1.8	J126111718010S		
IC04	nsp	IC F2621E-01-PR	J080260200040S		
IC05	nsp	IC SE1117-33-PF	J126111733020S		
IC06	nsp	IC AK4385	J042438500010S		
IC07	nsp	SN74LV08APW-EL2 +REF	00D2622517908		
IC08,09	nsp	SN74AHCT08PW-EL2 +C	00D2622813903		
IC10	nsp	IC NJM2068M	J121206800020S		
IC11	nsp	IC KIA7805AF-RTF/P	J126780500450S		
IC12	nsp	IC BU4094BCF-E2	J040140940030S		
IC801	nsp	ADSP21367KSZ1A1136	00D2623709016		
IC802	nsp	W9864G2GH-7	00D2623746008		
IC803	nsp	IC EN29LV160AB-70TIP	J005291600030S		
IC807	nsp	IC LC89057W-VF4A-E	J046890570030S		
IC808	nsp	ADAU1328BSTZ1136	00D2623645015		
IC809-811	nsp	IC SN74LVC244APWR	J040742440230S		
IC812	nsp	IC SN74HCT244PWR	J040742440220S		
IC814,815	nsp	IC SN74HCT00PWR	J040740000210S		
IC816	nsp	74LVX157MTC +C	00D2622870904		
IC823	nsp	IC KIA7805AF-RTF/P	J126780500450S		
IC825,826	nsp	IC SN74LVC74APWR	J040747400200S		
IC832	nsp	IC SE1117-33-PF	J126111733020S		
Q01,02	nsp	TR KRC102S	J522010200210S		
Q03,04	nsp	TR KRC104S	J522104S00210S		
Q07	nsp	TR KRC104S	J522104S00210S		
Q08	nsp	TR KRC102S	J522010200210S		
Q09	nsp	TR KRA104S	J520010400210S		
Q10,11	nsp	TR KRC102S	J522010200210S		
Q12,13	nsp	TR KRA102S	J520010200210S		
Q14-17	nsp	TR KTC2875B(MB)	J5222875B0010S		
Q18,19	nsp	TR KRC104S (ND)	J522104S00210S		
Q810D	nsp	TR KRC102S	J522010200210S		
Q811D	nsp	TR KRA102S	J520010200210S		
Q814D	nsp	TR KRA102S	J520010200210S		
D01-15	nsp	D,ESD IMSA-6802-01A	K067680200010S		
D17-32	nsp	D,ESD IMSA-6802-01A	K067680200010S		
D34-36	nsp	D,ESD IMSA-6802-01A	K067680200010S		
D37-44	nsp	D,SWITCHING KDS4148U	K005041480030S		
ZD101	nsp	D,ZENER 0.2W 5.1V UDZ	K06605R14P400S		
RESISTORS GROUP					
R41,42	nsp	COIL,BEAD MB-160808	D340160800060S		
R62	nsp	COIL,BEAD MB-160808	D340160800060S		
CAPACITORS GROUP					
C01	nsp	C,CERAMIC 1000PF-K/50V	D011102777160S		
C02-05	nsp	C,CERAMIC 0.1UF-K/50V	D011104577162S		
C06,07	nsp	C,CERAMIC 1000PF-K/50V	D011102777160S		
C08-14	nsp	C,CERAMIC 0.1UF-K/50V	D011104577162S		

Ref. No.	Part No.	Part Name	Remarks	Q'ty	New
C15-17	nsp	C,CERAMIC 1000PF-K/50V	D011102777160S		
C18,19	nsp	C,CERAMIC 0.1UF-K/50V	D011104577162S		
C20	nsp	C,CERAMIC 1000PF-K/50V	D011102777160S		
C21	nsp	C,CERAMIC 100PF-J/50V	D010101167160S		
C22	nsp	C,CERAMIC 1000PF-K/50V	D011102777160S		
C23	nsp	C,CERAMIC 100PF-J/50V	D010101167160S		
C24,25	nsp	C,ELECT 10UF-MVG/16V	D050100083460S		
C26,27	nsp	C,CERAMIC 0.01UF-K/50V	D011103777160S		
C28H	nsp	C,ELECT 10UF-MVG/16V	D050100083460S		
C29H	nsp	C,ELECT 10UF-MVG/16V	D050100083460S		
C30H	nsp	C,ELECT 10UF-MVG/16V	D050100083460S		
C33-36	nsp	C,CERAMIC 20PF-J/50V	D010200167160S		
C37-39	nsp	C,CERAMIC 0.1UF-K/50V	D011104577162S		
C40	nsp	C,ELECT 22UF-MV/6.3V	D050220081450S		
C41	nsp	C,CERAMIC 0.1UF-K/50V	D011104577162S		
C42,43	nsp	C,CERAMIC 5PF-C/50V	D010050107160S		
C44	nsp	C,CERAMIC 0.1UF-K/50V	D011104577162S		
C45	nsp	C,CERAMIC 1000PF-K/50V	D011102777160S		
C46	nsp	C,CERAMIC 4.7UF-K/10V	D011475572200S		
C47-50	nsp	C,CERAMIC 0.1UF-K/50V	D011104577162S		
C51	nsp	C,CERAMIC 1000PF-K/50V	D011102777160S		
C52	nsp	C,CERAMIC 0.1UF-K/50V	D011104577162S		
C53	nsp	C,ELECT 10UF-MVG/16V	D050100083460S		
C54	nsp	C,CERAMIC 0.1UF-K/50V	D011104577162S		
C55	nsp	C,CERAMIC 4.7UF-K/10V	D011475572200S		
C56,57	nsp	C,CERAMIC 1000PF-K/50V	D011102777160S		
C58	nsp	C,CERAMIC 0.1UF-K/50V	D011104577162S		
C59	nsp	C,CERAMIC 1000PF-K/50V	D011102777160S		
C60	nsp	C,CERAMIC 0.1UF-K/50V	D011104577162S		
C61	nsp	C,CERAMIC 1000PF-K/50V	D011102777160S		
C62	nsp	C,CERAMIC 0.1UF-K/50V	D011104577162S		
C63-65	nsp	C,CERAMIC 100PF-J/50V	D010101167160S		
C66	nsp	C,CERAMIC 0.01UF-K/50V	D011103777160S		
C68	nsp	C,ELECT 0.1UF-MVG/50V	D050R10080010S		
C69,70	nsp	C,CERAMIC 0.1UF-K/50V	D011104577162S		
C71,72	nsp	C,ELECT 22UF-MV/6.3V	D050220081450S		
C73,74	nsp	C,ELECT 10UF-MVG/16V	D050100083460S		
C75	nsp	C,CERAMIC 560PF-J/50V	D010561167160S		
C76	nsp	C,CERAMIC 1800PF-K/50V	D011182777160S		
C77,78	nsp	C,CERAMIC 560PF-J/50V	D010561167160S		
C79	nsp	C,CERAMIC 1800PF-K/50V	D011182777160S		
C80	nsp	C,CERAMIC 560PF-J/50V	D010561167160S		
C82	nsp	C,CERAMIC 1000PF-K/50V	D011102777160S		
C85,86	nsp	C,CERAMIC 0.047UF-Z/50V	D011473597160S		
C87,88	nsp	C,CERAMIC 0.01UF-K/50V	D011103777160S		
C831D	nsp	C,CERAMIC 0.1UF-K/50V	D011104577162S		
C832D	nsp	C,CERAMIC 1000PF-K/50V	D011102177101S		
C833D	nsp	C,CERAMIC 100PF-J/50V	D011101167101S		
C834D	nsp	C,CERAMIC 100PF-J/50V	D011101167101S		
C835D	nsp	C,CERAMIC 0.01UF-K/50V	D011103177101S		
C836D	nsp	C,CERAMIC 0.01UF-K/50V	D011103177101S		
C837D	nsp	C,CERAMIC 100PF-J/50V	D011101167101S		
C838D	nsp	C,CERAMIC 100PF-J/50V	D011101167101S		
C839D	nsp	C,CERAMIC 100PF-J/50V	D011101167101S		
C840D	nsp	C,CERAMIC 100PF-J/50V	D011101167101S		
C841D	nsp	C,CERAMIC 100PF-J/50V	D011101167101S		

Ref. No.	Part No.	Part Name	Remarks	Q'ty	New
C842D	nsp	C,CERAMIC 100PF-J/50V	D011101167101S		
C843D	nsp	C,CERAMIC 100PF-J/50V	D011101167101S		
C844D	nsp	C,CERAMIC 100PF-J/50V	D011101167101S		
C845D	nsp	C,CERAMIC 0.1UF-K/50V	D011104177101S		
C846D	nsp	C,CERAMIC 1000PF-K/50V	D011102177101S		
C847D	nsp	C,CERAMIC 1000PF-K/50V	D011102177101S		
C848D	nsp	C,CERAMIC 1000PF-K/50V	D011102177101S		
C849D	nsp	C,CERAMIC 1000PF-K/50V	D011102177101S		
C850D	nsp	C,CERAMIC 1000PF-K/50V	D011102177101S		
C851D	nsp	C,CERAMIC 1000PF-K/50V	D011102177101S		
C852D	nsp	C,CERAMIC 1000PF-K/50V	D011102177101S		
C853D	nsp	C,CERAMIC 1000PF-K/50V	D011102177101S		
C854D	nsp	C,CERAMIC 0.1UF-K/50V	D011104177101S		
C855D	nsp	C,CERAMIC 0.1UF-K/50V	D011104177101S		
C856D	nsp	C,CERAMIC 0.1UF-K/50V	D011104177101S		
C857D	nsp	C,CERAMIC 0.1UF-K/50V	D011104177101S		
C858D	nsp	C,CERAMIC 0.1UF-K/50V	D011104177101S		
C859D	nsp	C,CERAMIC 0.1UF-K/50V	D011104177101S		
C860D	nsp	C,CERAMIC 0.1UF-K/50V	D011104177101S		
C861D	nsp	C,CERAMIC 0.1UF-K/50V	D011104177101S		
C862D	nsp	C,CERAMIC 0.01UF-K/50V	D011103177101S		
C863D	nsp	C,CERAMIC 100PF-J/50V	D011101167101S		
C864D	nsp	C,CERAMIC 4.7UF-K/10V	D011475572200S		
C865D	nsp	C,CERAMIC 5PF-C/50V	D010050107160S		
C866D	nsp	C,CERAMIC 5PF-C/50V	D010050107160S		
C871D	nsp	C,CERAMIC 0.01UF-K/50V	D011103177101S		
C873D	nsp	C,CERAMIC 0.01UF-K/50V	D011103177101S		
C875D	nsp	C,CERAMIC 4.7UF-K/10V	D011475572200S		
C876D	nsp	C,CERAMIC 0.01UF-K/50V	D011103177101S		
C877D	nsp	C,CERAMIC 0.1UF-K/50V	D011104177101S		
C878D	nsp	C,CERAMIC 0.1UF-K/50V	D011104177101S		
C879D	nsp	C,CERAMIC 0.1UF-K/50V	D011104177101S		
C880D	nsp	C,CERAMIC 0.01UF-K/50V	D011103177101S		
C881D	nsp	C,CERAMIC 0.01UF-K/50V	D011103177101S		
C882D	nsp	C,CERAMIC 6PF-D/50V	D010060117160S		
C883D	nsp	C,CERAMIC 6PF-D/50V	D010060117160S		
C884D	nsp	C,CERAMIC 0.1UF-K/50V	D011104577162S		
C885D	nsp	C,CERAMIC 0.022UF-Z/50V	D011223597160S		
C886D	nsp	C,CERAMIC 0.1UF-K/50V	D011104177101S		
C887D	nsp	C,FILM 0.12UF-J/63V	D020124078060S		
C888D	nsp	C,CERAMIC 0.01UF-K/50V	D011103177101S		
C889D	nsp	C,CERAMIC 100PF-J/50V	D011101167101S		
C890D	nsp	C,CERAMIC 0.01UF-K/50V	D011103177101S		
C891D	nsp	C,CERAMIC 0.01UF-K/50V	D011103177101S		
C892D	nsp	C,CERAMIC 4.7UF-K/10V	D011475572200S		
C893D	nsp	C,CERAMIC 0.1UF-K/50V	D011104177101S		
C895D	nsp	C,CERAMIC 0.1UF-K/50V	D011104177101S		
C896D	nsp	C,CERAMIC 0.01UF-K/50V	D011103177101S		
C897D	nsp	C,CERAMIC 0.1UF-K/50V	D011104177101S		
C898D	nsp	C,CERAMIC 0.1UF-K/50V	D011104177101S		
C899D	nsp	C,CERAMIC 100PF-J/50V	D011101167101S		
C900D	nsp	C,CERAMIC 4.7UF-K/10V	D011475572200S		
C901D	nsp	C,ELECT 100UF-MVG/6.3V	D050101081650S		
C902D	nsp	C,CERAMIC 0.1UF-K/50V	D011104177101S		
C903D	nsp	C,CERAMIC 0.1UF-K/50V	D011104177101S		
C904D	nsp	C,CERAMIC 5600PF-K/50V	D011562777160S		

Ref. No.	Part No.	Part Name	Remarks	Q'ty	New
C905D	nsp	C,CERAMIC 390PF-J/50V	D010391167160S		
C906D	nsp	C,CERAMIC 0.1UF-K/50V	D011104177101S		
C907D	nsp	C,CERAMIC 0.1UF-K/50V	D011104177101S		
C908D	nsp	C,ELECT 47UF-MVG/6.3V	D050470081460S		
C909D	nsp	C,CERAMIC 0.1UF-K/50V	D011104177101S		
C910D	nsp	C,ELECT 10UF-MVG/16V	D050100083460S		
C911D	nsp	C,CERAMIC 0.01UF-K/50V	D011103177101S		
C913D	nsp	C,ELECT 10UF-MVG/16V	D050100083460S		
C914D	nsp	C,CERAMIC 0.01UF-K/50V	D011103177101S		
C915D	nsp	C,ELECT 10UF-MVG/16V	D050100083460S		
C916D	nsp	C,CERAMIC 0.1UF-K/50V	D011104577162S		
C917D	nsp	C,CERAMIC 0.1UF-K/50V	D011104577162S		
C918D	nsp	C,CERAMIC 0.1UF-K/50V	D011104577162S		
C919D	nsp	C,CERAMIC 0.1UF-K/50V	D011104577162S		
OTHERS PARTS GROUP					
BD801-804	nsp	COIL,BEAD MB-160808	D340160800060S		
BD807D	nsp	COIL,BEAD MB-160808	D340160800060S		
BD808D-02	nsp	COIL,BEAD MB-160808	D340160800060S		
CB03	nsp	R,CHIP THICK 0-J,1/16W	C20000006M160S		
CB06	nsp	COIL,BEAD MB-160808	D340160800060S		
CN01	nsp	CN.WAFER 16P	L101100031610S		
CN802	nsp	CN.HOUSING 16P	L120912160010S		
CN803	nsp	CN.WAFER 16P	L101100031610S		
CN804	nsp	CN.HOUSING 15P	L120912150010S		
CN805	nsp	CN.HOUSING 08P	L120912080010S		
CP201	nsp	CN.WAFER 9P	L101220090000S		
CP404	nsp	CN.WAFER 4P	L101220040000S		
CP405	nsp	CN.WAFER 5P	L101220050000S		
CP406	nsp	CN.WAFER 3P	L101220030000S		
CP904	nsp	CN.WAFER 6P	L101220060010S		
J806	nsp	R,CHIP THICK 0-J,1/16W	C20000006M101S		
JACK01-03	00D 963 0388 504	19PIN HDMI CONNECTOR	L109100190020S		
JACK04	nsp	CAM-D96 4PIN SMALL COCNNETOR	L109040000020S		
X01	nsp	CRYSTAL FCX-02(45.1584MHz)	E80545R150020S		
X803D	nsp	FCX-03(16.660MHz)	00D3991091905		
X804D	nsp	FCX-03(24.576MHz)	00D3991053901		
LUG901	nsp	RING,TER WIRE 70MM/1P	8410700010070S		

VIDEO P.W.B. UNIT ASS'Y

Ref. No.	Part No.	Part Name	Remarks	Q'ty	New
SEMICONDUCTORS GROUP					
IC1001	00D 963 0133 500	IC BA7626FP	J171762600010S		
IC1002	00D 963 0068 002	IC BU4052BCF-E2	J040405200060S		
IC1003	00D 963 0074 504	IC BU2090F-E2	J044209000010S		
IC1005,1006	00D 963 0133 500	IC BA7626FP	J171762600010S		
IC1007	00D 963 0068 002	IC BU4052BCF-E2 P	J040405200060S		
IC1008	00D 963 0340 801	IC NJW1321FP1	J171132100010S		
IC1011,1012	00D 263 1082 903	TK15420MTL +C	J127154200010S		
IC1013	00D 963 0367 503	IC SE1117-1.8	J126111718010S		
IC1014	00D 963 0111 603	IC SE1117-33-PF	J126111733020S		
IC1016	00D 963 0295 406	IC IC BH7868FS	J127786800000S		
IC1017	00D 262 3425 905	LTC4300-2CMS8	J040430000000S		
IC1018	00D 262 3643 004	ADV7180BSTZ	J044718000010S		
IC1019	00D 262 3644 003	ADV7172KSTZ	J045717200011S		
IC1151	00D 263 1082 903	TK15420MTL +C	J127154200010S		
IC1157	00D 263 1082 903	TK15420MTL +C	J127154200010S		
IC1160	00D 263 1082 903	TK15420MTL +C	J127154200010S		
IC1162,1163	00D 263 1082 903	TK15420MTL +C	J127154200010S		
IC1164	00D 963 0327 604	IC NJM2581M	J127258100010S		
Q1001	00D 963 0148 508	TRKTA1504S	J520015040150S		
Q1002	00D 960 0296 309	TR KRC111S (NM)	J522011100210S		
Q1003,1004	00D 963 0120 704	TR KRA102S	J520010200210S		
Q1005,1006	00D 963 0102 803	TR 2SA933S	J5000933S0050S		
Q1011,1012	00D 963 0120 704	TR KRA102S	J520010200210S		
Q1013,1014	00D 963 0148 508	TRKTA1504S	J520015040150S		
Q1015,1016	00D 960 0296 309	TR KRC111S (NM)	J522011100210S		
Q1017	00D 963 0120 801	TR KRC102S	J522010200210S		
Q1018	00D 963 0121 606	TR KRC107S	J522107S00210S		
Q1019	00D 963 0102 803	TR 2SA933S	J5000933S0050S		
Q1020	00D 960 0285 006	TR KRC104S	J522104S00210S		
Q1021-1025	00D 963 0148 508	TRKTA1504S	J520015040150S		
Q1026	00D 960 0285 006	TR KRC104S	J522104S00210S		
D1001	00D 963 0355 401	D,SWITCHING KDS4148U	K005041480030S		
D1005	00D 963 0355 401	D,SWITCHING KDS4148U	K005041480030S		
D1009,1010	00D 963 9006 599	R,CHIP THICK 0-J,1/10W	C200000060200S		
D1011-1014	00D 963 0355 401	D,SWITCHING KDS4148U	K005041480030S		
D1021-1024	00D 963 0355 401	D,SWITCHING KDS4148U	K005041480030S		
RESISTORS GROUP					
R1008	00D 963 9005 639	R,METAL FILM 100-J,1W	C060010165060S		
R1096	00D 963 9005 639	R,METAL FILM 100-J,1W	C060010165060S		
R1100	00D 963 9005 639	R,METAL FILM 100-J,1W	C060010165060S		
VR1001-1005	00D9630367606	R,CHIP 100ohm 1/16W	C20001014M160S		
CAPACITORS GROUP					
C1002-1004	00D 963 9006 544	C,ELECT 22UF-M/25V	D040220084050S		
C1005	00D 960 0298 802	C,ELECT 470UF-M/6.3V	D040471081070S		
C1006	00D 963 0234 205	C,ELECT 10UF-M/50V	D040100087070S		
C1007,1008	nsp	C,CERAMIC 0.01UF-K/50V	D011103777160S		
C1009	00D 963 0293 602	C,ELECT 1UF-M/50V (Pb Free)	D040010087150S		

Ref. No.	Part No.	Part Name	Remarks	Q'ty	New
C1010	00D 963 0293 709	C,ELECT 100UF-M/10V	D040101082070S		
C1011	nsp	C,CERAMIC 0.047UF-Z/50V	D011473597160S		
C1012,1013	nsp	C,CERAMIC 0.01UF-K/50V	D011103777160S		
C1014,1015	nsp	C,CERAMIC 100PF-J/50V	D010101167160S		
C1016,1017	nsp	C,CERAMIC 0.01UF-K/50V	D011103777160S		
C1018	00D 963 0293 709	C,ELECT 100UF-M/10V	D040101082070S		
C1019,1020	00D 963 9006 544	C,ELECT 22UF-M/25V	D040220084050S		
C1021	00D 963 0293 709	C,ELECT 100UF-M/10V	D040101082070S		
C1022	nsp	C,CERAMIC 0.01UF-K/50V	D011103777160S		
C1023-1025	00D 963 0293 709	C,ELECT 100UF-M/10V	D040101082070S		
C1026	nsp	C,CERAMIC 0.01UF-K/50V	D011103777160S		
C1027,1028	00D 963 9006 544	C,ELECT 22UF-M/25V	D040220084050S		
C1029,1030	nsp	C,CERAMIC 0.01UF-K/50V	D011103777160S		
C1032,1033	00D 963 0234 205	C,ELECT 10UF-M/50V	D040100087070S		
C1035,1036	00D 963 0294 106	C,ELECT 2.2UF-M/50V (Pb Free)	D0402R2087160S		
C1037	nsp	C,CERAMIC 0.01UF-K/50V	D011103777160S		
C1038,1039	00D 963 0234 205	C,ELECT 10UF-M/50V	D040100087070S		
C1041	00D 960 0298 802	C,ELECT 470UF-M/6.3V	D040471081070S		
C1042	00D 960 9010 023	C,ELECT 0.47UF-M/50V	D040R47087050S		
C1043,1044	00D 963 0234 205	C,ELECT 10UF-M/50V	D040100087070S		
C1045-1050	00D 963 9006 544	C,ELECT 22UF-M/25V	D040220084050S		
C1051,1052	nsp	C,CERAMIC 0.01UF-K/50V	D011103777160S		
C1053,1054	00D 963 0293 602	C,ELECT 1UF-M/50V (Pb Free)	D040010087150S		
C1055,1056	nsp	C,CERAMIC 0.047UF-Z/50V	D011473597160S		
C1057,1058	nsp	C,CERAMIC 0.01UF-K/50V	D011103777160S		
C1059,1060	00D 963 0223 009	R,THICK 0-J,1/16W	C20000006M160S		
C1061-1069	nsp	C,CERAMIC 0.1UF-K/50V	D011104577160S		
C1070-1078	00D 963 0234 205	C,ELECT 10UF-M/50V	D040100087070S		
C1079-1082	nsp	C,CERAMIC 0.1UF-K/50V	D011104577160S		
C1083	00D 963 0276 409	C,ELECT 100UF-M/16V	D040101083090S		
C1084,1085	nsp	C,CERAMIC 0.1UF-K/50V	D011104577160S		
C1086	00D 963 0234 205	C,ELECT 10UF-M/50V	D040100087070S		
C1087	nsp	C,CERAMIC 0.1UF-K/50V	D011104577160S		
C1088	00D 963 0234 205	C,ELECT 10UF-M/50V	D040100087070S		
C1089	nsp	C,CERAMIC 0.1UF-K/50V	D011104577160S		
C1090	00D 963 0234 205	C,ELECT 10UF-M/50V	D040100087070S		
C1091	nsp	C,CERAMIC 0.1UF-K/50V	D011104577160S		
C1092	00D 963 0276 409	C,ELECT 100UF-M/16V	D040101083090S		
C1093	00D 963 0293 602	C,ELECT 1UF-M/50V (Pb Free)	D040010087150S		
C1094	nsp	C,CERAMIC 0.047UF-Z/50V	D011473597160S		
C1095-1097	nsp	C,CERAMIC 0.01UF-K/50V	D011103777160S		
C1098	00D 963 0293 602	C,ELECT 1UF-M/50V (Pb Free)	D040010087150S		
C1099-1101	00D 963 0293 709	C,ELECT 100UF-M/10V	D040101082070S		
C1102	nsp	C,CERAMIC 0.01UF-K/50V	D011103777160S		
C1103	00D 963 9006 544	C,ELECT 22UF-M/25V	D040220084050S		
C1104	00D 963 0293 709	C,ELECT 100UF-M/10V	D040101082070S		
C1105	00D 963 9006 544	C,ELECT 22UF-M/25V	D040220084050S		
C1106	00D 963 0293 709	C,ELECT 100UF-M/10V	D040101082070S		
C1107	00D 963 9006 544	C,ELECT 22UF-M/25V	D040220084050S		
C1108,1109	00D 963 0293 709	C,ELECT 100UF-M/10V	D040101082070S		
C1113	00D 963 0144 706	C,FILM 0.01UF-J/50V	D020103167050S		
C1114	nsp	C,CERAMIC 100PF-J/50V	D010101167160S		
C1115	00D 963 0130 105	C,FILM 1UF-K/63V	D020105078060S		
C1116	nsp	C,CERAMIC 0.01UF-K/50V	D011103777160S		
C1117	nsp	C,CERAMIC 100PF-J/50V	D010101167160S		
C1118	00D 963 0024 907	C,ELECT 1000UF-M/6.3V	D040102081060S		

Ref. No.	Part No.	Part Name	Remarks	Q'ty	New
C1119,1120	nsp	C,CERAMIC 0.1UF-K/50V	D011104577160S		
C1121,1122	00D 963 0234 108	C,FILM 0.1UF-J/50V	D020104167050S		
C1123	nsp	C,CERAMIC 0.047UF-Z/50V	D011473597160S		
C1124-1126	00D 963 0234 205	C,ELECT 10UF-M/50V	D040100087070S		
C1127	00D 963 9006 544	C,ELECT 22UF-M/25V	D040220084050S		
C1128	00D 963 0234 205	C,ELECT 10UF-M/50V	D040100087070S		
C1129,1130	00D 963 9006 557	C,ELECT 220UF-M/6.3V	D040221081060S		
C1131	00D 963 0324 403	C,ELECT 33UF-M/35V	D040330085050S		
C1132,1133	00D 963 0144 706	C,FILM 0.01UF-J/50V	D020103167050S		
C1134	00D 960 0298 802	C,ELECT 470UF-M/6.3V	D040471081070S		
C1135	00D 963 0144 706	C,FILM 0.01UF-J/50V	D020103167050S		
C1136,1137	nsp	C,CERAMIC 0.1UF-K/50V	D011104577160S		
C1138	00D 963 0234 205	C,ELECT 10UF-M/50V	D040100087070S		
C1139,1140	nsp	C,CERAMIC 0.1UF-K/50V	D011104577160S		
C1141	nsp	C,CERAMIC 0.01UF-K/50V	D011103777160S		
C1142	00D 963 0234 108	C,FILM 0.1UF-J/50V	D020104167050S		
C1143	nsp	C,CERAMIC 0.1UF-K/50V	D011104577160S		
C1144	00D 963 0324 403	C,ELECT 33UF-M/35V	D040330085050S		
C1145	00D 960 0298 802	C,ELECT 470UF-M/6.3V	D040471081070S		
C1146	nsp	C,CERAMIC 1000PF-K/50V	D011102777160S		
C1147	nsp	C,CERAMIC 0.01UF-K/50V	D011103777160S		
C1148	00D 963 0324 403	C,ELECT 33UF-M/35V	D040330085050S		
C1149	nsp	C,CERAMIC 0.1UF-K/50V	D011104577160S		
C1150	nsp	C,CERAMIC 0.01UF-K/50V	D011103777160S		
C1151	nsp	C,CERAMIC 0.1UF-K/50V	D011104577160S		
C1152	00D 963 0303 000	C,CERAMIC 0.082UF-K/50V	D010823777160S		
C1153	nsp	C,CERAMIC 0.01UF-K/50V	D011103777160S		
C1154	nsp	C,CERAMIC 1000PF-K/50V	D011102777160S		
C1155	nsp	C,CERAMIC 0.01UF-K/50V	D011103777160S		
C1156,1157	00D 963 0234 108	C,FILM 0.1UF-J/50V	D020104167050S		
C1158	nsp	C,CERAMIC 0.1UF-K/50V	D011104577160S		
C1159	nsp	C,CERAMIC 1000PF-K/50V	D011102777160S		
C1160	nsp	C,CERAMIC 100PF-J/50V	D010101167160S		
C1161	nsp	C,CERAMIC 1000PF-K/50V	D011102777160S		
C1162	nsp	C,CERAMIC 0.1UF-K/50V	D011104577160S		
C1163	nsp	C,CERAMIC 100PF-J/50V	D010101167160S		
C1164,1165	nsp	C,CERAMIC 47PF-J/50V	D010470167160S		
C1166,1167	nsp	C,CERAMIC 0.1UF-K/50V	D011104577160S		
C1168	nsp	C,CERAMIC 1000PF-K/50V	D011102777160S		
C1169	nsp	C,CERAMIC 0.01UF-K/50V	D011103777160S		
C1170	nsp	C,CERAMIC 0.1UF-K/50V	D011104577160S		
C1171	nsp	C,CERAMIC 1000PF-K/50V	D011102777160S		
C1172,1173	00D 960 0298 802	C,ELECT 470UF-M/6.3V	D040471081070S		
C1174-1176	00D 963 0234 108	C,FILM 0.1UF-J/50V	D020104167050S		
C1177	nsp	C,CERAMIC 0.01UF-K/50V	D011103777160S		
C1178	nsp	C,CERAMIC 0.1UF-K/50V	D011104577160S		
C1179	nsp	C,CERAMIC 1000PF-K/50V	D011102777160S		
C1180	nsp	C,CERAMIC 0.1UF-K/50V	D011104577160S		
C1181,1182	nsp	C,CERAMIC 1000PF-K/50V	D011102777160S		
C1183	nsp	C,CERAMIC 0.1UF-K/50V	D011104577160S		
C1184	nsp	C,CERAMIC 100PF-J/50V	D010101167160S		
C1185	nsp	C,CERAMIC 1000PF-K/50V	D011102777160S		
C1186	nsp	C,CERAMIC 100PF-J/50V	D010101167160S		
C1187-1189	nsp	C,CERAMIC 0.1UF-K/50V	D011104577160S		
C1190,1191	nsp	C,CERAMIC 1000PF-K/50V	D011102777160S		
C1192-1194	nsp	C,CERAMIC 0.1UF-K/50V	D011104577160S		

Ref. No.	Part No.	Part Name	Remarks	Q'ty	New
C1198-1200	nsp	C,CERAMIC 0.01UF-K/50V	D011103777160S		
C1201,1202	00D 963 0324 403	C,ELECT 33UF-M/35V	D040330085050S		
C1203-1206	nsp	C,CERAMIC 0.01UF-K/50V	D011103777160S		
C1207	00D 963 0276 409	C,ELECT 100UF-M/16V	D040101083090S		
C1208	nsp	C,CERAMIC 0.01UF-K/50V	D011103777160S		
C1209	00D 963 0276 409	C,ELECT 100UF-M/16V	D040101083090S		
C1210	nsp	C,CERAMIC 0.01UF-K/50V	D011103777160S		
C1211	00D 963 0276 409	C,ELECT 100UF-M/16V	D040101083090S		
OTHERS PARTS GROUP					
BD1001-1003	nsp	COIL,BEAD MB-160808	D340160800060S		
CN406	nsp	CN,WIRE 300MM/3P	L000301030060S		
CN1001	nsp	CN.WAFER 8P	L101100030810S		
CN1002	nsp	CN.WAFER 9P	L101100030910S		
CP514	nsp	CN.WAFER 8P	L101220080010S		
JACK1001,1002	00D 963 0367 709	TER,RCA 6PIN	G603610D0032YS		
JACK1003	00D 963 0218 001	TER,RCA 2PIN	G60122001000YS		
JACK1004	00D 963 0218 108	TER,RCA 3PIN	G60630401000YS		
L1003-1006	nsp	COIL INDUCTOR 22UH	D330220010520S		
X1011	00D 963 0294 407	CRYSTAL 28.63636MHZ	E80028R636010S		

HDMI_PWR P.W.B. UNIT ASS'Y

Ref. No.	Part No.	Part Name	Remarks	Q'ty	New
SEMICONDUCTORS GROUP					
IC401H1	00D9630366500	IC KIA1117PI33	J126111733050S		
CAPACITORS GROUP					
C405H1	00D 963 0234 205	C,ELECT 10UF-M/50V	D040100087070S		
C406H1	00D9630233303	C,CERAMIC 0.01UF-M/16V	D005103773530S		
OTHERS PARTS GROUP					
CN404	nsp	CN,WIRE 300MM/4P	L000301040110S		
CP513	nsp	CN.WAFER 3P ANGLE	L102526803010S		

PARTS LIST OF P.W.B. UNIT



AVR-1508 E3 MODEL

* 本表に "nsp" と記載されている部品は供給できません。

* Parts for which "nsp" is indicated on this table cannot be supplied.

* 本表に記載されている部品は、補修用部品のため製品に使用している部品とは一部、形状、寸法などが異なる場合があります。

* The parts listed below are for maintenance only, might differ from the parts used in the unit in appearances or dimensions.

MAIN P.W.B. UNIT ASS'Y

Ref. No.	Part No.	Part Name	Remarks	Q'ty	New
SEMICONDUCTORS GROUP					
IC110,111	00D 963 0218 807	IC BU4094BCF-E2	J040140940030S		
IC231	00D 960 0174 104	IC CXA1511M-T4	J030151100010S		
Q101	00D 960 0196 302	TR KTA1268BL	J5001268B0050S		
Q102-104	00D 960 0196 700	TR KTC3200BL	J5023200B0050S		
Q104C	00D 960 0196 506	TR KSC1845F	J5021845F0000S		
Q104FL	00D 960 0196 506	TR KSC1845F	J5021845F0000S		
Q104FR	00D 960 0196 506	TR KSC1845F	J5021845F0000S		
Q104SL	00D 960 0196 506	TR KSC1845F	J5021845F0000S		
Q104SR	00D 960 0196 506	TR KSC1845F	J5021845F0000S		
Q105	00D 960 0196 700	TR KTC3200BL	J5023200B0050S		
Q105C	00D 960 0196 603	TR KTC2874B	J502287400010S		
Q105FL	00D 960 0196 603	TR KTC2874B	J502287400010S		
Q105FR	00D 960 0196 603	TR KTC2874B	J502287400010S		
Q105SL	00D 960 0196 603	TR KTC2874B	J502287400010S		
Q105SR	00D 960 0196 603	TR KTC2874B	J502287400010S		
Q106	00D 960 0196 700	TR KTC3200BL	J5023200B0050S		
Q106C	00D 960 0196 205	TR KSA992F	J5000992F0050S		
Q106FL	00D 960 0196 205	TR KSA992F	J5000992F0050S		
Q106FR	00D 960 0196 205	TR KSA992F	J5000992F0050S		
Q106SL	00D 960 0196 205	TR KSA992F	J5000992F0050S		
Q106SR	00D 960 0196 205	TR KSA992F	J5000992F0050S		
Q107	00D 960 0196 700	TR KTC3200BL	J5023200B0050S		
Q107C	00D 960 0196 205	TR KSA992F	J5000992F0050S		
Q107FL	00D 960 0196 205	TR KSA992F	J5000992F0050S		
Q107FR	00D 960 0196 205	TR KSA992F	J5000992F0050S		
Q107SL	00D 960 0196 205	TR KSA992F	J5000992F0050S		
Q107SR	00D 960 0196 205	TR KSA992F	J5000992F0050S		
Q108	00D 960 0196 700	TR KTC3200BL	J5023200B0050S		
Q108C	00D 960 0196 506	TR KSC1845F	J5021845F0000S		
Q108FL	00D 960 0196 506	TR KSC1845F	J5021845F0000S		
Q108FR	00D 960 0196 506	TR KSC1845F	J5021845F0000S		
Q108SL	00D 960 0196 506	TR KSC1845F	J5021845F0000S		
Q108SR	00D 960 0196 506	TR KSC1845F	J5021845F0000S		
Q109,110	00D 960 0196 700	TR KTC3200BL	J5023200B0050S		
Q111	00D 960 0196 302	TR KTA1268BL	J5001268B0050S		
Q130	00D 960 0196 302	TR KTA1268BL	J5001268B0050S		
Q131,132	00D 963 0219 602	TR KRC106M	J6020106M0010S		
Q133-137	00D 960 0097 207	TR KRA102M	J6002202M0010S		
Q141SW	00D 963 0044 301	TR KTC2875B(MB)	J5222875B0010S		
Q142	00D 960 0196 700	TR KTC3200BL	J5023200B0050S		
Q142SW	00D 963 0044 301	TR KTC2875B(MB)	J5222875B0010S		
Q143,144	00D 960 0196 302	TR KTA1268BL	J5001268B0050S		
Q145	00D 960 0196 700	TR KTC3200BL	J5023200B0050S		
Q146,147	00D 960 0196 302	TR KTA1268BL	J5001268B0050S		
Q151	00D 960 0196 302	TR KTA1268BL	J5001268B0050S		
Q156	00D 960 0097 304	TR KRC102M	J6020102M0010S		
Q165	00D 960 0196 700	TR KTC3200BL	J5023200B0050S		

Ref. No.	Part No.	Part Name	Remarks	Q'ty	New
Q166-171	00D 960 0196 302	TR KTA1268BL	J5001268B0050S		
Q231	00D 960 0097 003	TR KRA104M	J6000104M0010S		
Q541	00D 963 0121 208	TR KRC107M	J6020107M0010S		
D101C	00D 963 0355 401	D,SWITCHING KDS4148U	K005041480030S		
D101FL	00D 963 0355 401	D,SWITCHING KDS4148U	K005041480030S		
D101FR	00D 963 0355 401	D,SWITCHING KDS4148U	K005041480030S		
D101SL	00D 963 0355 401	D,SWITCHING KDS4148U	K005041480030S		
D101SR	00D 963 0355 401	D,SWITCHING KDS4148U	K005041480030S		
D102C	00D 963 0355 401	D,SWITCHING KDS4148U	K005041480030S		
D102FL	00D 963 0355 401	D,SWITCHING KDS4148U	K005041480030S		
D102FR	00D 963 0355 401	D,SWITCHING KDS4148U	K005041480030S		
D102SL	00D 963 0355 401	D,SWITCHING KDS4148U	K005041480030S		
D102SR	00D 963 0355 401	D,SWITCHING KDS4148U	K005041480030S		
D105C	00D 963 0020 309	D,SWITCHING 1SS133T	K000013300520S		
D105FL	00D 963 0020 309	D,SWITCHING 1SS133T	K000013300520S		
D105FR	00D 963 0020 309	D,SWITCHING 1SS133T	K000013300520S		
D105SL	00D 963 0020 309	D,SWITCHING 1SS133T	K000013300520S		
D105SR	00D 963 0020 309	D,SWITCHING 1SS133T	K000013300520S		
D106,107	00D 963 0355 401	D,SWITCHING KDS4148U	K005041480030S		
D114,115	00D 960 0197 107	D,RECTIFIER BRIDGE KBPC604	K047604000020S		
D139	00D 963 0020 309	D,SWITCHING 1SS133T	K000013300520S		
D140,141	00D 963 0328 409	D,SWITCHING 1N4007	K000400700010S		
D142	00D 963 0355 401	D,SWITCHING KDS4148U	K005041480030S		
D143-152	00D 963 0020 309	D,SWITCHING 1SS133T	K000013300520S		
D153	00D 963 0355 401	D,SWITCHING KDS4148U	K005041480030S		
D154-157	00D 963 0020 309	D,SWITCHING 1SS133T	K000013300520S		
D231	00D 963 0355 401	D,SWITCHING KDS4148U	K005041480030S		
D541	00D 963 0355 401	D,SWITCHING KDS4148U	K005041480030S		
ZD101	00D 963 0058 601	D,ZENER MTZJ12B	K06012R044520S		
ZD101C	00D 963 0367 008	D,ZENER 0.2W 3.3V UDZ	K06603R34P400S		
ZD101FL	00D 963 0367 008	D,ZENER 0.2W 3.3V UDZ	K06603R34P400S		
ZD101FR	00D 963 0367 008	D,ZENER 0.2W 3.3V UDZ	K06603R34P400S		
ZD101SL	00D 963 0367 008	D,ZENER 0.2W 3.3V UDZ	K06603R34P400S		
ZD101SR	00D 963 0367 008	D,ZENER 0.2W 3.3V UDZ	K06603R34P400S		
ZD102C	00D 963 0367 008	D,ZENER 0.2W 3.3V UDZ	K06603R04P400S		
ZD102FL	00D 963 0367 008	D,ZENER 0.2W 3.3V UDZ	K06603R04P400S		
ZD102FR	00D 963 0367 008	D,ZENER 0.2W 3.3V UDZ	K06603R04P400S		
ZD102SL	00D 963 0367 008	D,ZENER 0.2W 3.3V UDZ	K06603R04P400S		
ZD102SR	00D 963 0367 008	D,ZENER 0.2W 3.3V UDZ	K06603R04P400S		
ZD105	00D 960 0095 500	D,ZENER MTZJ5.1B	K06005R144520S		
ZD231	00D 960 0095 704	D,ZENER MTZJ6.2B	K06006R244520S		
RESISTORS GROUP					
R101	00D 963 0337 801	R,METAL FILM 100-J,2W	C060010166520S		
R103	00D 963 9005 639	R,METAL FILM 100-J,1W	C060010165060S		
R104	00D 963 0215 907	R,METAL FILM 4.7-J,1W	C0604R7065050S		
R104C	00D 963 9006 285	R,FIXED 1WJ-5.6K	N113135656220S		
R104FL	00D 963 9006 285	R,FIXED 1WJ-5.6K	N113135656220S		
R104FR	00D 963 9006 285	R,FIXED 1WJ-5.6K	N113135656220S		
R104SL	00D 963 9006 285	R,FIXED 1WJ-5.6K	N113135656220S		
R104SR	00D 963 9006 285	R,FIXED 1WJ-5.6K	N113135656220S		
R105	00D 963 0232 906	R,METAL FILM 47K-F,1/4W	C060047343530S		
R105C	00D 963 9006 285	R,FIXED 1WJ-5.6K	N113135656220S		

Ref. No.	Part No.	Part Name	Remarks	Q'ty	New
R105FL	00D 963 9006 285	R, FIXED 1WJ-5.6K	N113135656220S		
R105FR	00D 963 9006 285	R, FIXED 1WJ-5.6K	N113135656220S		
R105SL	00D 963 9006 285	R, FIXED 1WJ-5.6K	N113135656220S		
R105SR	00D 963 9006 285	R, FIXED 1WJ-5.6K	N113135656220S		
R106C	00D 963 0215 907	R, METAL FILM 4.7-J, 1W	C0604R7065050S		
R106FL	00D 963 0215 907	R, METAL FILM 4.7-J, 1W	C0604R7065050S		
R106FR	00D 963 0215 907	R, METAL FILM 4.7-J, 1W	C0604R7065050S		
R106SL	00D 963 0215 907	R, METAL FILM 4.7-J, 1W	C0604R7065050S		
R106SR	00D 963 0215 907	R, METAL FILM 4.7-J, 1W	C0604R7065050S		
R107C	00D 963 0215 907	R, METAL FILM 4.7-J, 1W	C0604R7065050S		
R107FL	00D 963 0215 907	R, METAL FILM 4.7-J, 1W	C0604R7065050S		
R107FR	00D 963 0215 907	R, METAL FILM 4.7-J, 1W	C0604R7065050S		
R107SL	00D 963 0215 907	R, METAL FILM 4.7-J, 1W	C0604R7065050S		
R107SR	00D 963 0215 907	R, METAL FILM 4.7-J, 1W	C0604R7065050S		
R108C	00D 963 0345 903	R, FIXED 2WJ-0.47	N113136647820S		
R108FL	00D 963 0345 903	R, FIXED 2WJ-0.47	N113136647820S		
R108FR	00D 963 0345 903	R, FIXED 2WJ-0.47	N113136647820S		
R108SL	00D 963 0345 903	R, FIXED 2WJ-0.47	N113136647820S		
R108SR	00D 963 0345 903	R, FIXED 2WJ-0.47	N113136647820S		
R109C	00D 963 0345 903	R, FIXED 2WJ-0.47	N113136647820S		
R109FL	00D 963 0345 903	R, FIXED 2WJ-0.47	N113136647820S		
R109FR	00D 963 0345 903	R, FIXED 2WJ-0.47	N113136647820S		
R109SL	00D 963 0345 903	R, FIXED 2WJ-0.47	N113136647820S		
R109SR	00D 963 0345 903	R, FIXED 2WJ-0.47	N113136647820S		
R110C	00D 963 0345 903	R, FIXED 2WJ-0.47	N113136647820S		
R110FL	00D 963 0345 903	R, FIXED 2WJ-0.47	N113136647820S		
R110FR	00D 963 0345 903	R, FIXED 2WJ-0.47	N113136647820S		
R110SL	00D 963 0345 903	R, FIXED 2WJ-0.47	N113136647820S		
R110SR	00D 963 0345 903	R, FIXED 2WJ-0.47	N113136647820S		
R111C	00D 963 0345 903	R, FIXED 2WJ-0.47	N113136647820S		
R111FL	00D 963 0345 903	R, FIXED 2WJ-0.47	N113136647820S		
R111FR	00D 963 0345 903	R, FIXED 2WJ-0.47	N113136647820S		
R111SL	00D 963 0345 903	R, FIXED 2WJ-0.47	N113136647820S		
R111SR	00D 963 0345 903	R, FIXED 2WJ-0.47	N113136647820S		
R117,118	00D 963 0144 502	R, CEMENT 0.1-J 5W	C141R10069000S		
R118C	00D 963 9006 256	R, FIXED 1WJ-10	N113135610020S		
R118FL	00D 963 9006 256	R, FIXED 1WJ-10	N113135610020S		
R118FR	00D 963 9006 256	R, FIXED 1WJ-10	N113135610020S		
R118SL	00D 963 9006 256	R, FIXED 1WJ-10	N113135610020S		
R118SR	00D 963 9006 256	R, FIXED 1WJ-10	N113135610020S		
R119C	00D 963 9006 256	R, FIXED 1WJ-10	N113135610020S		
R119FL	00D 963 9006 256	R, FIXED 1WJ-10	N113135610020S		
R119FR	00D 963 9006 256	R, FIXED 1WJ-10	N113135610020S		
R119SL	00D 963 9006 256	R, FIXED 1WJ-10	N113135610020S		
R119SR	00D 963 9006 256	R, FIXED 1WJ-10	N113135610020S		
R127C	00D 963 9005 642	R, METAL FILM 1.2K-J, 1W	C060012265050S		
R127FL	00D 963 9005 642	R, METAL FILM 1.2K-J, 1W	C060012265050S		
R127FR	00D 963 9005 642	R, METAL FILM 1.2K-J, 1W	C060012265050S		
R127SL	00D 963 9005 642	R, METAL FILM 1.2K-J, 1W	C060012265050S		
R127SR	00D 963 9005 642	R, METAL FILM 1.2K-J, 1W	C060012265050S		
R132C	00D 960 9010 719	R, METAL FILM 47-J, 1W	C060047065060S		
R132FL	00D 960 9010 719	R, METAL FILM 47-J, 1W	C060047065060S		
R132FR	00D 960 9010 719	R, METAL FILM 47-J, 1W	C060047065060S		
R132SL	00D 960 9010 719	R, METAL FILM 47-J, 1W	C060047065060S		
R132SR	00D 960 9010 719	R, METAL FILM 47-J, 1W	C060047065060S		
R147-149	00D 963 9005 642	R, METAL FILM 1.2K-J, 1W	C060012265050S		

Ref. No.	Part No.	Part Name	Remarks	Q'ty	New
VR101C	00D 960 0221 109	VR,SEMI CARBON EVN-DJAA03B	C541102115000S		
VR101FL	00D 960 0221 109	VR,SEMI CARBON EVN-DJAA03B	C541102115000S		
VR101FR	00D 960 0221 109	VR,SEMI CARBON EVN-DJAA03B	C541102115000S		
VR101SL	00D 960 0221 109	VR,SEMI CARBON EVN-DJAA03B	C541102115000S		
VR101SR	00D 960 0221 109	VR,SEMI CARBON EVN-DJAA03B	C541102115000S		
CAPACITORS GROUP					
C101	00D 963 9005 804	C,ELECT 100UF-M/25V	D040101084060S		
C101C	00D 963 0234 506	C,ELECT 47UF-M/50V (Pb Free)	D040470087070S		
C101FL	00D 963 0234 506	C,ELECT 47UF-M/50V (Pb Free)	D040470087070S		
C101FR	00D 963 0234 506	C,ELECT 47UF-M/50V (Pb Free)	D040470087070S		
C101SL	00D 963 0234 506	C,ELECT 47UF-M/50V (Pb Free)	D040470087070S		
C101SR	00D 963 0234 506	C,ELECT 47UF-M/50V (Pb Free)	D040470087070S		
C102	00D 963 0224 503	C,ELECT 22UF-M/50V	D040220087060S		
C102C	00D 963 0234 205	C,ELECT 10UF-M/50V	D040100087070S		
C102FL	00D 960 9010 133	C,ELECT 220UF-M/35V	D040221085060S		
C102FR	00D 960 9010 133	C,ELECT 220UF-M/35V	D040221085060S		
C102SL	00D 963 0234 205	C,ELECT 10UF-M/50V	D040100087070S		
C102SR	00D 963 0234 205	C,ELECT 10UF-M/50V	D040100087070S		
C103	00D 963 9006 557	C,ELECT 220UF-M/6.3V	D040221081060S		
C103C	00D 963 9003 084	C,CERAMIC 100PF-K/500V	D00410106D050S		
C103FL	00D 963 9003 084	C,CERAMIC 100PF-K/500V	D00410106D050S		
C103FR	00D 963 9003 084	C,CERAMIC 100PF-K/500V	D00410106D050S		
C103SL	00D 963 9003 084	C,CERAMIC 100PF-K/500V	D00410106D050S		
C103SR	00D 963 9003 084	C,CERAMIC 100PF-K/500V	D00410106D050S		
C104	00D 963 9006 557	C,ELECT 220UF-M/6.3V	D040221081060S		
C104C	00D 963 9003 084	C,CERAMIC 100PF-K/500V	D00410106D050S		
C104FL	00D 963 9003 084	C,CERAMIC 100PF-K/500V	D00410106D050S		
C104FR	00D 963 9003 084	C,CERAMIC 100PF-K/500V	D00410106D050S		
C104SL	00D 963 9003 084	C,CERAMIC 100PF-K/500V	D00410106D050S		
C104SR	00D 963 9003 084	C,CERAMIC 100PF-K/500V	D00410106D050S		
C105	00D 963 9006 557	C,ELECT 220UF-M/6.3V	D040221081060S		
C105C	nsp	C,CERAMIC 0.022UF-Z/50V	D011223597160S		
C105FL	nsp	C,CERAMIC 0.022UF-Z/50V	D011223597160S		
C105FR	nsp	C,CERAMIC 0.022UF-Z/50V	D011223597160S		
C105SL	nsp	C,CERAMIC 0.022UF-Z/50V	D011223597160S		
C105SR	nsp	C,CERAMIC 0.022UF-Z/50V	D011223597160S		
C106	00D 963 0293 709	C,ELECT 100UF-M/10V	D040101082070S		
C107	nsp	C,CERAMIC 0.01UF-K/50V	D011103777160S		
C107C	00D 963 9003 097	C,FILM 0.1UF-K/250V	D02010407H080S		
C107FL	00D 963 9003 097	C,FILM 0.1UF-K/250V	D02010407H080S		
C107FR	00D 963 9003 097	C,FILM 0.1UF-K/250V	D02010407H080S		
C107SL	00D 963 9003 097	C,FILM 0.1UF-K/250V	D02010407H080S		
C107SR	00D 963 9003 097	C,FILM 0.1UF-K/250V	D02010407H080S		
C108	00D 963 0149 400	CAP.E.GENERIC 10000UF/63V	N211210388110S		
C108C	00D 963 9006 544	C,ELECT 22UF-M/25V	D040220084050S		
C108FL	00D 963 9006 544	C,ELECT 22UF-M/25V	D040220084050S		
C108FR	00D 963 9006 544	C,ELECT 22UF-M/25V	D040220084050S		
C108SL	00D 963 9006 544	C,ELECT 22UF-M/25V	D040220084050S		
C108SR	00D 963 9006 544	C,ELECT 22UF-M/25V	D040220084050S		
C109	00D 963 0149 400	CAP.E.GENERIC 10000UF/63V	N211210388110S		
C109C	00D 963 0234 205	C,ELECT 10UF-M/50V	D040100087070S		
C109FL	00D 963 0234 205	C,ELECT 10UF-M/50V	D040100087070S		
C109FR	00D 963 0234 205	C,ELECT 10UF-M/50V	D040100087070S		

Ref. No.	Part No.	Part Name	Remarks	Q'ty	New
C109SL	00D 963 0234 205	C,ELECT 10UF-M/50V	D040100087070S		
C109SR	00D 963 0234 205	C,ELECT 10UF-M/50V	D040100087070S		
C110	00D 963 9003 097	C,FILM 0.1UF-K/250V	D02010407H080S		
C110C	00D 963 0338 208	C,CERAMIC 470PF-K/500V	D00447127D050S		
C110FL	00D 963 0338 208	C,CERAMIC 470PF-K/500V	D00447127D050S		
C110FR	00D 963 0338 208	C,CERAMIC 470PF-K/500V	D00447127D050S		
C110SL	00D 963 0338 208	C,CERAMIC 470PF-K/500V	D00447127D050S		
C110SR	00D 963 0338 208	C,CERAMIC 470PF-K/500V	D00447127D050S		
C111	00D 963 9003 097	C,FILM 0.1UF-K/250V	D02010407H080S		
C111C	00D 963 0367 101	C,CERAMIC 220PF-J/500V	D00422106D05CS		
C111FL	00D 963 0367 101	C,CERAMIC 220PF-J/500V	D00422106D05CS		
C111FR	00D 963 0367 101	C,CERAMIC 220PF-J/500V	D00422106D05CS		
C111SL	00D 963 0367 101	C,CERAMIC 220PF-J/500V	D00422106D05CS		
C111SR	00D 963 0367 101	C,CERAMIC 220PF-J/500V	D00422106D05CS		
C112	00D 963 9003 097	C,FILM 0.1UF-K/250V	D02010407H080S		
C112C	00D 963 9003 194	C,FILM 0.0022UF-J/100V	D02022206C060S		
C112FL	00D 963 9003 194	C,FILM 0.0022UF-J/100V	D02022206C060S		
C112FR	00D 963 9003 194	C,FILM 0.0022UF-J/100V	D02022206C060S		
C112SL	00D 963 9003 194	C,FILM 0.0022UF-J/100V	D02022206C060S		
C112SR	00D 963 9003 194	C,FILM 0.0022UF-J/100V	D02022206C060S		
C113C	00D 963 0293 709	C,ELECT 100UF-M/10V	D040101082070S		
C113FL	00D 960 9010 133	C,ELECT 220UF-M/35V	D040221085060S		
C113FR	00D 960 9010 133	C,ELECT 220UF-M/35V	D040221085060S		
C113SL	00D 963 0293 709	C,ELECT 100UF-M/10V	D040101082070S		
C113SR	00D 963 0293 709	C,ELECT 100UF-M/10V	D040101082070S		
C114	00D 963 9003 097	C,FILM 0.1UF-K/250V	D02010407H080S		
C114C	00D 963 0216 100	C,CERAMIC 33PF-J/500V	D00033006D050S		
C114FL	00D 963 0216 100	C,CERAMIC 33PF-J/500V	D00033006D050S		
C114FR	00D 963 0216 100	C,CERAMIC 33PF-J/500V	D00033006D050S		
C114SL	00D 963 0216 100	C,CERAMIC 33PF-J/500V	D00033006D050S		
C114SR	00D 963 0216 100	C,CERAMIC 33PF-J/500V	D00033006D050S		
C115	00D 963 9003 097	C,FILM 0.1UF-K/250V	D02010407H080S		
C115SW	00D 963 9006 544	C,ELECT 22UF-M/25V	D040220084050S		
C117-120	nsp	C,CERAMIC 0.1UF-K/50V	D011104577160S		
C141SW1	00D 963 0234 205	C,ELECT 10UF-M/50V	D040100087070S		
C142SW1	nsp	C,CERAMIC 100PF-J/50V	D010101167160S		
C161	00D 963 0234 205	C,ELECT 10UF-M/50V	D040100087070S		
C162,163	nsp	C,CERAMIC 0.01UF-K/50V	D011103777160S		
C164-167	nsp	C,CERAMIC 100PF-J/50V	D010101167160S		
C168-172	00D 963 0244 606	C,ELECT 0.1UF-M/50V (Pb Free)	D040R10087080S		
C177	nsp	C,CERAMIC 0.01UF-K/50V	D011103777160S		
C178,179	00D 960 9010 010	C,ELECT 4.7UF-M/50V	D0404R7087250S		
C180,181	nsp	C,CERAMIC 0.01UF-K/50V	D011103777160S		
C182	00D 963 0324 005	C,ELECT 100UF-M/100V	D04010108C240S		
C183	00D 963 0293 602	C,ELECT 1UF-M/50V (Pb Free)	D040010087150S		
C190	00D 960 9010 010	C,ELECT 4.7UF-M/50V	D0404R7087250S		
C231	00D 963 0244 606	C,ELECT 0.1UF-M/50V (Pb Free)	D040R10087080S		
C232	nsp	C,CERAMIC 0.01UF-K/50V	D011103777160S		
C233	00D 963 0293 602	C,ELECT 1UF-M/50V (Pb Free)	D040010087150S		
C234	nsp	C,CERAMIC 100PF-J/50V	D010101167160S		
C235,236	00D 960 9008 653	C,FILM 0.012UF-J/100V	D02012306C060S		
C237	00D 963 9005 862	C,ELECT 47UF-M/16V	D040470083080S		
OTHERS PARTS GROUP					
BKT101	nsp	SHIELD PLATE GND	3070045526010S		

Ref. No.	Part No.	Part Name	Remarks	Q'ty	New
CN101	nsp	CN,WIRE 14P	L000111140010S		
CN103	nsp	CN,WIRE 7P	L000141070020S		
CN201	nsp	CN,WIRE 4P	L000700100020S		
CN511		CN,WIRE 60MM/9P	L000600090020S		
CN704	nsp	CN,WIRE 15P	L000600150030S		
CP103	nsp	CN.WAFER 3P	L102526700300S		
CP104	nsp	CN.WAFER 3CKT	L108353280360S		
CP106	nsp	CN.WAFER 5P	L101100040510S		
CP107	nsp	CN.WAFER 3P	L102526700300S		
CP108	nsp	CN.WAFER 17P	L101100041710S		
CP541	nsp	CN.WAFER 3P	L101220030000S		
GND101	nsp	TERMINAL EARTH	3790040886000S		
JACK222	00D 963 0146 005	TER,RCA 1PIN	G600107A0000YS		
JACK231,232	00D 963 0244 703	JACK,D3.5 EARPHONE	G40130802000YS		
L101C	00D 963 0049 005	COIL INDUCTOR 0.5UH	D330R50000000S		
L101FL	00D 963 0049 005	COIL INDUCTOR 0.5UH	D330R50000000S		
L101FR	00D 963 0049 005	COIL INDUCTOR 0.5UH	D330R50000000S		
L101SL	00D 963 0049 005	COIL INDUCTOR 0.5UH	D330R50000000S		
L101SR	00D 963 0049 005	COIL INDUCTOR 0.5UH	D330R50000000S		
L231	nsp	BEAD,COIL 3580	7610010030000S		
RLY541	00D 963 0218 506	RELAY BC3-24 24V 2A	G680240202040S		
TP101-105	nsp	CN.WAFER 3P	L101530140310S		
JP108	00D 963 0223 009	R,CHIP THICK 0-J,1/16W	C20000006M160S		
JP350-352	00D 963 0223 009	R,CHIP THICK 0-J,1/16W	C20000006M160S		

FRONT P.W.B. UNIT ASS'Y

Ref. No.	Part No.	Part Name	Remarks	Q'ty	New
SEMICONDUCTORS GROUP					
IC301	00D 963 0074 504	IC BU2090F-E2	J044209000010S		
IC302	00D 262 3758 009	LC87F6D64A-QFP-E	J127876160010S		
△ IC303	00D 960 0195 808	IC ICP-N15	J120001500030S		
Q301-303	00D 963 0120 704	TR KRA102S	J520010200210S		
Q304	00D 963 0121 606	TR KRC107S	J522107S00210S		
Q305	00D 963 0102 803	TR 2SA933S	J5000933S0050S		
Q306	00D 963 0120 801	TR KRC102S	J522010200210S		
Q307-309	00D 963 0120 704	TR KRA102S	J520010200210S		
Q310,311	00D 963 0120 801	TR KRC102S	J522010200210S		
Q312	00D 960 0133 103	TR KSA916Y	J5000916Y0050S		
Q542-546	00D 963 0121 208	TR KRC107M	J6020107M0010S		
D301,302	00D 963 0020 309	D,SWITCHING 1SS133T	K000013300520S		
D303	00D 963 0355 401	D,SWITCHING KDS4148U	K005041480030S		
D304	00D 963 0020 309	D,SWITCHING 1SS133T	K000013300520S		
D305-311	00D 963 0355 401	D,SWITCHING KDS4148U	K005041480030S		
D312	00D 963 0328 409	D,SWITCHING 1N4007	K000400700010S		
D313-316	00D 963 0355 401	D,SWITCHING KDS4148U	K005041480030S		
D542	00D 963 0020 309	D,SWITCHING 1SS133T	K000013300520S		
D543-545	00D 963 0355 401	D,SWITCHING KDS4148U	K005041480030S		
D546	00D 963 0020 309	D,SWITCHING 1SS133T	K000013300520S		
ZD302-305	00D 960 0095 500	D,ZENER MTZJ5.1B	K06005R144520S		
ZD307,308	00D 960 0095 500	D,ZENER MTZJ5.1B	K06005R144520S		
ZD309	00D 960 0095 801	D,ZENER MTZJ6.8B	K06006R844520S		
ZD310,311	00D 963 0046 202	D,ZENER MTZJ18B	K06018R044520S		
LED302-309	00D 960 0197 204	LED PI5-RD/HL50RDRF4T	K500052015010S		
LED310	00D 963 0366 108	LED BL-BEG204-L 5PI	K500052004010S		
FL301	00D 963 0257 305	DISPLAY,FLT HNA-16SM13T	K530161300020S		
RESISTORS GROUP					
R372	00D 963 0215 907	R,METAL FILM 4.7-J,1W	C0604R7065050S		
R378,379	00D 960 9009 270	R,METAL FILM 470-J,2W	C060047166520S		
R501	00D9609003700	R,METAL FILM 10-J,1/4W	C060010063050S		
RP1-38	00D 963 0353 005	R,CHIP THICK 56K-J,1/16W	C20005636M160S		
RG1-16	00D 963 0353 005	R,CHIP THICK 56K-J,1/16W	C20005636M160S		
CAPACITORS GROUP					
C301,302	nsp	C,CERAMIC 100PF-J/50V	D010101167160S		
C303	nsp	C,CERAMIC 0.022UF-K/25V	D011223777160S		
C304	00D 963 9005 862	C,ELECT 47UF-M/16V	D040470083080S		
C305	nsp	C,CERAMIC 100PF-J/50V	D010101167160S		
C306	nsp	C,CERAMIC 0.047UF-Z/50V	D011473597160S		
C307	00D 963 9005 862	C,ELECT 47UF-M/16V	D040470083080S		
C308	nsp	C,CERAMIC 0.01UF-K/50V	D011103777160S		
C311	00D 963 0233 303	C,CERAMIC 0.01UF-M/16V	D005103773530S		
C312	00D 963 9005 862	C,ELECT 47UF-M/16V	D040470083080S		

Ref. No.	Part No.	Part Name	Remarks	Q'ty	New
C316,317	nsp	C,CERAMIC 330PF-J/50V	D010331167160S		
C319,320	nsp	C,CERAMIC 0.01UF-K/50V	D011103777160S		
C321,322	00D 963 0233 303	C,CERAMIC 0.01UF-M/16V	D005103773530S		
C324,325	00D 963 0293 602	C,ELECT 1UF-M/50V (Pb Free)	D040010087150S		
C326	00D 963 9005 862	C,ELECT 47UF-M/16V	D040470083080S		
C327,328	nsp	C,CERAMIC 0.1UF-K/50V	D011104577160S		
C329	nsp	C,FILM 0.1UF-J/100V	D02010406C060S		
C330	00D 963 0021 900	C,FILM 0.047UF-J/100V	D02047306C060S		
C333	00D 963 0293 602	C,ELECT 1UF-M/50V (Pb Free)	D040010087150S		
C334	00D 963 0021 900	C,FILM 0.047UF-J/100V	D02047306C060S		
C339	nsp	C,CERAMIC 100PF-J/50V	D010101167160S		
C340	nsp	C,CERAMIC 1000PF-K/50V	D011102777160S		
C341,342	nsp	C,CERAMIC 100PF-J/50V	D010101167160S		
C343	00D 963 0020 202	C,CERAMIC 0.1UF-Z/50V	D005104597530S		
C344,345	00D 963 0233 206	C,CERAMIC 0.001UF-K/50V	D005102177530S		
C346-349	nsp	C,CERAMIC 0.01UF-K/50V	D011103777160S		
C350	00D 963 0021 900	C,FILM 0.047UF-J/100V	D02047306C060S		
C351	00D 963 0293 602	C,ELECT 1UF-M/50V (Pb Free)	D040010087150S		
C352	00D 963 0234 205	C,ELECT 10UF-M/50V	D040100087070S		
C353,354	00D 963 0293 602	C,ELECT 1UF-M/50V (Pb Free)	D040010087150S		
C355	nsp	C,ELECT 470UF-M/63V	D040471088010S		
C356	00D 963 9003 097	C,FILM 0.1UF-K/250V	D02010407H080S		
C357,358	nsp	C,CERAMIC 0.047UF-Z/50V	D011473597160S		
C541	nsp	C,CERAMIC 2200PF-K/50V	D011222777160S		
C541FL	00D 963 0024 703	C,FILM 0.01UF-J/100V	D02010306C060S		
C542	nsp	C,CERAMIC 2200PF-K/50V	D011222777160S		
C542FR	00D 963 0024 703	C,FILM 0.01UF-J/100V	D02010306C060S		
C543	nsp	C,CERAMIC 2200PF-K/50V	D011222777160S		
C543FL	00D 963 0024 703	C,FILM 0.01UF-J/100V	D02010306C060S		
C544	nsp	C,CERAMIC 2200PF-K/50V	D011222777160S		
C544FR	00D 963 0024 703	C,FILM 0.01UF-J/100V	D02010306C060S		
C545	nsp	C,CERAMIC 2200PF-K/50V	D011222777160S		
C545C	00D 963 0024 703	C,FILM 0.01UF-J/100V	D02010306C060S		
C546	nsp	C,CERAMIC 2200PF-K/50V	D011222777160S		
C546SL	00D 963 0024 703	C,FILM 0.01UF-J/100V	D02010306C060S		
C547	nsp	C,CERAMIC 2200PF-K/50V	D011222777160S		
C547SR	00D 963 0024 703	C,FILM 0.01UF-J/100V	D02010306C060S		
C548	nsp	C,CERAMIC 2200PF-K/50V	D011222777160S		
C548SBL	00D 963 0024 703	C,FILM 0.01UF-J/100V	D02010306C060S		
C549	nsp	C,CERAMIC 2200PF-K/50V	D011222777160S		
C549SBR	00D 963 0024 703	C,FILM 0.01UF-J/100V	D02010306C060S		
OTHERS PARTS GROUP					
BD301-304		COIL,BEAD MB-160808	D340160800060S		
CN102	nsp	CN,WIRE 270,170MM/4P	L000271040040S		
CN301	nsp	CN,WIRE 2P	L000401020050S		
CN303A	nsp	CN,WIRE 8P	L000450080010S		
CN304	nsp	CN,WIRE 3P	L000500030050S		
CN305	nsp	CN,WIRE 10P	L000700100030S		
CN541	nsp	CN,WIRE 3P	L000251030080S		
CP101	nsp	CN.WAFER 10P	L102526701000S		
CP103	nsp	CN.WAFER 7P	L101220070000S		
CP105	nsp	CN.WAFER 4P ANGLE	L102526800400S		

Ref. No.	Part No.	Part Name	Remarks	Q'ty	New
CP301B	00D 963 0368 506	CN.FPC 35P	L131103500010S		
CP302	nsp	CN.WAFER 3P ANGLE	L102526803010S		
CP304	nsp	CN.WAFER 3P	L101220030000S		
CP305	nsp	CN.WAFER 10P	L101220100010S		
CP306	nsp	CN.WAFER 03P	L101220030010S		
G301	nsp	RING,TER WIRE 120MM/1P	8410121010060S		
G302	nsp	RING,TER WIRE 120MM/1P	8410121010110S		
G304	nsp	RING,TER WIRE 70MM/1P	8410700010070S		
JACK304	00D 963 0146 403	TER,RCA 3PIN	G606308HG110YS		
JACK501,502	00D 963 0146 607	TER,BOARD SCREW 8P	G614801A0200YS		
JACK503	00D 963 0158 608	TER,BOARD SCREW 2P	G611201A0200YS		
JK302	00D 963 0294 708	JACK,D6.5 PHONE	G402PJ612AG0YS		
L302	nsp	COIL INDUCTOR 10UH	D330100700520S		
L303	nsp	COIL INDUCTOR 100UH	D330101001020S		
RLY541	00D 963 0366 201	RELAY G5PA-28-MC 24V 5A	G680240502030S		
RLY543-546	00D 963 0366 201	RELAY G5PA-28-MC 24V 5A	G680240502030S		
RMC301	00D 963 0217 808	MODULE,REMOCON NJL34H380A	E940343800010S		
⚠ SW301	00D 963 0145 802	SW,PUSH SDDL-005-S(C-UL)	G000122006060S		
SW301A	00D 963 0095 305	SW,TACT SKHV10910D01	G180040500010S		
SW301C	00D 963 0095 305	SW,TACT SKHV10910D01	G180040500010S		
SW302A	00D 963 0095 305	SW,TACT SKHV10910D01	G180040500010S		
SW302B	00D 963 0095 305	SW,TACT SKHV10910D01	G180040500010S		
SW302C	00D 963 0095 305	SW,TACT SKHV10910D01	G180040500010S		
SW303A	00D 963 0095 305	SW,TACT SKHV10910D01	G180040500010S		
SW303B	00D 963 0095 305	SW,TACT SKHV10910D01	G180040500010S		
SW303C	00D 963 0095 305	SW,TACT SKHV10910D01	G180040500010S		
SW304A	00D 963 0095 305	SW,TACT SKHV10910D01	G180040500010S		
SW304B	00D 963 0095 305	SW,TACT SKHV10910D01	G180040500010S		
SW304C	00D 963 0095 305	SW,TACT SKHV10910D01	G180040500010S		
SW305A	00D 963 0095 305	SW,TACT SKHV10910D01	G180040500010S		
SW305B	00D 963 0095 305	SW,TACT SKHV10910D01	G180040500010S		
SW305C	00D 963 0095 305	SW,TACT SKHV10910D01	G180040500010S		
SW306A	00D 963 0095 305	SW,TACT SKHV10910D01	G180040500010S		
SW306B	00D 963 0095 305	SW,TACT SKHV10910D01	G180040500010S		
SW306C	00D 963 0095 305	SW,TACT SKHV10910D01	G180040500010S		
SW307A	00D 963 0095 305	SW,TACT SKHV10910D01	G180040500010S		
SW307B	00D 963 0095 305	SW,TACT SKHV10910D01	G180040500010S		
SW307C	00D 963 0095 305	SW,TACT SKHV10910D01	G180040500010S		
SW308A	00D 963 0095 305	SW,TACT SKHV10910D01	G180040500010S		
SW308B	00D 963 0095 305	SW,TACT SKHV10910D01	G180040500010S		
SW308C	00D 963 0095 305	SW,TACT SKHV10910D01	G180040500010S		
SW309A	00D 963 0095 305	SW,TACT SKHV10910D01	G180040500010S		
SW310	00D 963 0095 305	SW,TACT SKHV10910D01	G180040500010S		
VEC203	00D 963 0300 401	SW,ENCODER EC11B20C2	G121112020000S		
VEC301	00D 963 0095 305	SW,ENCODER EC16B24SO	G121162400070S		
VEC303	00D 963 0095 305	SW,ENCODER EC16B24SO	G121162400070S		
	nsp	HOLDER FLT	4320200026000S		

INPUT P.W.B. UNIT ASS'Y

Ref. No.	Part No.	Part Name	Remarks	Q'ty	New
SEMICONDUCTORS GROUP					
IC700	00D 963 0366 304	IC R2A15215FP		J084152150010S	
IC702	00D 963 0024 004	IC NJM2068M		J121206800020S	
IC705-718	00D 963 0024 004	IC NJM2068M		J121206800020S	
Q700,701	00D 960 0196 807	TR 2SK117Y		J5441170Y0050S	
Q702	00D 963 0120 704	TR KRA102S		J520010200210S	
Q703	00D 960 0285 006	TR KRC104S		J522104S00210S	
D700,701	00D 963 0355 401	D,SWITCHING KDS4148U		K005041480030S	
ZD700,701	00D 960 0222 603	D,ZENER MTZJ7.5A		K06007R544530S	
RESISTORS GROUP					
R706-709	00D 963 9005 639	R,METAL FILM 100-J,1W		C060010165060S	
R791VC	nsp	R,METAL FILM 120-J,1W		C060012165060S	
R791VE	nsp	R,METAL FILM 120-J,1W		C060012165060S	
CAPACITORS GROUP					
C700	00D 963 0234 205	C,ELECT 10UF-M/50V		D040100087070S	
C702SW	00D 960 9010 010	C,ELECT 4.7UF-M/50V		D0404R7087250S	
C703C	nsp	C,CERAMIC 0.047UF-Z/50V		D011473597160S	
C703SW	nsp	C,CERAMIC 0.047UF-Z/50V		D011473597160S	
C704,705	00D 963 9005 875	C,ELECT 47UF-M/25V		D040470084070S	
C706FL	00D 963 9005 875	C,ELECT 47UF-M/25V		D040470084070S	
C706FR	00D 963 9005 875	C,ELECT 47UF-M/25V		D040470084070S	
C707FL	00D 963 0234 205	C,ELECT 10UF-M/50V		D040100087070S	
C707FR	00D 963 0234 205	C,ELECT 10UF-M/50V		D040100087070S	
C707SW	00D 963 0234 205	C,ELECT 10UF-M/50V		D040100087070S	
C708FL	nsp	C,CERAMIC 33PF-J/50V		D010330167160S	
C708FR	nsp	C,CERAMIC 33PF-J/50V		D010330167160S	
C708SW	nsp	C,CERAMIC 47PF-J/50V		D010470167160S	
C709FL	nsp	C,CERAMIC 0.047UF-Z/50V		D011473597160S	
C709FR	nsp	C,CERAMIC 0.047UF-Z/50V		D011473597160S	
C709SW	nsp	C,CERAMIC 0.047UF-Z/50V		D011473597160S	
C710	00D 963 0223 009	R,CHIP THICK 0-J,1/16W		C20000006M160S	
C710FL	nsp	C,CERAMIC 100PF-J/50V		D010101167160S	
C710FR	nsp	C,CERAMIC 100PF-J/50V		D010101167160S	
C710SW	nsp	C,CERAMIC 100PF-J/50V		D010101167160S	
C711	00D 963 0223 009	R,CHIP THICK 0-J,1/16W		C20000006M160S	
C711FL	nsp	C,CERAMIC 0.047UF-Z/50V		D011473597160S	
C711FR	nsp	C,CERAMIC 0.047UF-Z/50V		D011473597160S	
C711SW	nsp	C,CERAMIC 0.047UF-Z/50V		D011473597160S	
C712	00D 963 0293 602	C,ELECT 1UF-M/50V (Pb Free)		D040010087150S	
C713-715	00D 963 0223 009	R,CHIP THICK 0-J,1/16W		C20000006M160S	
C716-727	00D 960 9009 814	C,CERAMIC 330PF-J/50V		D010331167160S	
C728-731	nsp	C,CERAMIC 20PF-J/50V		D010200167160S	
C732-739	00D 960 9009 814	C,CERAMIC 330PF-J/50V		D010331167160S	
C740-751	00D 963 0234 205	C,ELECT 10UF-M/50V		D040100087070S	
C751A	00D 963 0234 205	C,ELECT 10UF-M/50V		D040100087070S	
C751B	00D 963 0234 205	C,ELECT 10UF-M/50V		D040100087070S	
C751C	00D 963 0234 205	C,ELECT 10UF-M/50V		D040100087070S	
C751D	00D 963 0234 205	C,ELECT 10UF-M/50V		D040100087070S	

Ref. No.	Part No.	Part Name	Remarks	Q'ty	New
C751E	00D 963 0234 205	C,ELECT 10UF-M/50V	D040100087070S		
C751F	00D 963 0234 205	C,ELECT 10UF-M/50V	D040100087070S		
C751G	00D 963 0234 205	C,ELECT 10UF-M/50V	D040100087070S		
C751H	00D 963 0234 205	C,ELECT 10UF-M/50V	D040100087070S		
C751J	00D 963 0234 205	C,ELECT 10UF-M/50V	D040100087070S		
C751K	00D 963 0234 205	C,ELECT 10UF-M/50V	D040100087070S		
C751L	00D 963 0234 205	C,ELECT 10UF-M/50V	D040100087070S		
C751M	00D 963 0234 205	C,ELECT 10UF-M/50V	D040100087070S		
C751N	00D 963 0234 205	C,ELECT 10UF-M/50V	D040100087070S		
C751P	00D 963 0234 205	C,ELECT 10UF-M/50V	D040100087070S		
C751Q	00D 963 0234 205	C,ELECT 10UF-M/50V	D040100087070S		
C751R	00D 963 0234 205	C,ELECT 10UF-M/50V	D040100087070S		
C751S	00D 963 0234 205	C,ELECT 10UF-M/50V	D040100087070S		
C751T	00D 963 0234 205	C,ELECT 10UF-M/50V	D040100087070S		
C751U	00D 963 0234 205	C,ELECT 10UF-M/50V	D040100087070S		
C751V	00D 963 0234 205	C,ELECT 10UF-M/50V	D040100087070S		
C752	00D 963 0234 205	C,ELECT 10UF-M/50V	D040100087070S		
C752A	nsp	C,CERAMIC 0.047UF-Z/50V	D011473597160S		
C752B	nsp	C,CERAMIC 0.047UF-Z/50V	D011473597160S		
C752C	nsp	C,CERAMIC 0.047UF-Z/50V	D011473597160S		
C752D	nsp	C,CERAMIC 0.047UF-Z/50V	D011473597160S		
C752E	nsp	C,CERAMIC 0.047UF-Z/50V	D011473597160S		
C752F	nsp	C,CERAMIC 0.047UF-Z/50V	D011473597160S		
C752G	nsp	C,CERAMIC 0.047UF-Z/50V	D011473597160S		
C752H	nsp	C,CERAMIC 0.047UF-Z/50V	D011473597160S		
C752J	nsp	C,CERAMIC 0.047UF-Z/50V	D011473597160S		
C752K	nsp	C,CERAMIC 0.047UF-Z/50V	D011473597160S		
C752L	nsp	C,CERAMIC 0.047UF-Z/50V	D011473597160S		
C752M	nsp	C,CERAMIC 0.047UF-Z/50V	D011473597160S		
C752N	nsp	C,CERAMIC 0.047UF-Z/50V	D011473597160S		
C752P	nsp	C,CERAMIC 0.047UF-Z/50V	D011473597160S		
C752Q	nsp	C,CERAMIC 0.047UF-Z/50V	D011473597160S		
C752R	nsp	C,CERAMIC 0.047UF-Z/50V	D011473597160S		
C752S	nsp	C,CERAMIC 0.047UF-Z/50V	D011473597160S		
C752T	nsp	C,CERAMIC 0.047UF-Z/50V	D011473597160S		
C752U	nsp	C,CERAMIC 0.047UF-Z/50V	D011473597160S		
C752V	nsp	C,CERAMIC 0.047UF-Z/50V	D011473597160S		
C752W	nsp	C,CERAMIC 0.1UF-Z/50V	D011104597160S		
C752X	nsp	C,CERAMIC 0.1UF-Z/50V	D011104597160S		
C753-771	00D 963 0234 205	C,ELECT 10UF-M/50V	D040100087070S		
C772,773	00D 963 0293 806	C,ELECT 100UF-M/10V (Pb Free)	D040101082090S		
C774	nsp	C,FILM 0.15UF-K/63V	D020154078060S		
C775	00D 963 0021 900	C,FILM 0.047UF-J/100V	D02047306C060S		
C776	00D 960 9008 640	C,FILM 0.022UF-J/100V	D02022306C060S		
C777	00D 963 0234 205	C,ELECT 10UF-M/50V	D040100087070S		
C778,779	nsp	C,CERAMIC 100PF-J/50V	D010101167160S		
C780	00D 963 0234 205	C,ELECT 10UF-M/50V	D040100087070S		
C781	00D 960 9008 640	C,FILM 0.022UF-J/100V	D02022306C060S		
C782	00D 963 0021 900	C,FILM 0.047UF-J/100V	D02047306C060S		
C783	nsp	C,FILM 0.15UF-K/63V	D020154078060S		
C784-790	00D 963 0293 806	C,ELECT 100UF-M/10V (Pb Free)	D040101082090S		
C791-793	00D 963 0234 205	C,ELECT 10UF-M/50V	D040100087070S		
C794	00D 963 0293 806	C,ELECT 100UF-M/10V (Pb Free)	D040101082090S		
C795-799	00D 963 0234 205	C,ELECT 10UF-M/50V	D040100087070S		
C800,801	00D 960 9010 832	C,ELECT 10UF-M/16V	D040100083050S		

Ref. No.	Part No.	Part Name	Remarks	Q'ty	New
OTHERS PARTS GROUP					
CLAMP501	nsp	CLAMP WIRE(SOLDER)		4330000120000S	
CN306	nsp	CN,WIRE 480MM/3P		L000481030060S	
CN514	nsp	CN,WIRE 13P		L000181130010S	
CN702	nsp	CN.HOUSING 15P		L120912150010S	
CN703	nsp	CN.WAFER 8P		L101100030810S	
CN704	nsp	CN.WAFER 19P		L101100031910S	
CN706		CN,WIRE 5P		L000121050080S	
CP704	nsp	CN.WAFER 15P		L101220150000S	
CP705	nsp	CN.WAFER 3P		L101220030000S	
JACK701	00D 963 0132 103	TER,RCA 4PIN		G602405B0400YS	
JACK702	00D 963 0387 505	TER,RCA 4PIN		G602405B5500YS	
JACK703	00D 963 0132 103	TER,RCA 4PIN		G602405B0400YS	
JACK704,705	00D 963 0132 307	TER,RCA 6PIN		G603603B05000S	

POWER P.W.B. UNIT ASS'Y

	Ref. No.	Part No.	Part Name	Remarks	Q'ty	New
SEMICONDUCTORS GROUP						
△	IC501	00D 963 0057 806	IC KIA78R05PI	J126780500370S		
	IC502	00D 960 0195 808	IC ICP-N15	J120001500030S		
	IC515	00D 960 0174 900	IC KIA7815API	J126781500000S		
	IC516	00D 963 0021 502	IC KIA7915PI	J126791500030S		
	IC517	00D 960 0100 301	IC KIA7812API	J126781200040S		
	Q501	00D 960 0196 409	TR 2SC1740SR	J5021740S0010S		
	Q502	00D 963 0121 208	TR KRC107M	J6020107M0010S		
	Q503	00D 960 0196 409	TR 2SC1740SR	J5021740S0010S		
	D501-503	00D 276 0401 905	D,SWITCHING 1SS133T	K000013300520S		
	D504-507	00D 963 0328 409	D,SWITCHING 1N4007	K000400700010S		
	D508,509	00D 276 0401 905	D,SWITCHING 1SS133T	K000013300520S		
	D521,522	00D 276 0401 905	D,SWITCHING 1SS133T	K000013300520S		
	D523-526	00D 963 0328 409	D,SWITCHING 1N4007	K000400700010S		
	ZD501	00D 960 0095 500	D,ZENER MTZJ5.1B	K06005R144520S		
	ZD502	00D 963 0219 903	D,ZENER MTZJ16B	K06016R044520S		
RESISTORS GROUP						
	R506	00D 963 0244 305	R,METAL FILM 2.2M 0.5W	C060022564520S		
	R507	00D 963 0232 809	R,METAL FILM 10-J,1/4W	C060010063520S		
	R516-519	00D 963 0216 003	R,METAL FILM 0.22-J,1W	C060R22065050S		
	R520	00D 963 0215 907	R,METAL FILM 4.7-J,1W	C0604R7065050S		
CAPACITORS GROUP						
	C501	00D 963 0234 205	C,ELECT 10UF-M/50V	D040100087070S		
	C502	00D 963 0217 002	C,ELECT 3300UF-M/16V	D040332083010S		
	C503	00D 963 0293 602	C,ELECT 1UF-M/50V (Pb Free)	D040010087150S		
	C504	00D 963 0323 802	C,CERAMIC AC(SAFETY) 0.0047UF 250VAC	D00847208H010S		
	C506	00D 963 0293 602	C,ELECT 1UF-M/50V (Pb Free)	D040010087150S		
	C526,527	00D 960 0186 202	C,ELECT 220UF-M/35V	D040221085050S		
	C528	00D 963 0324 908	C,ELECT 4700UF-M/35V	D040472085020S		
	C529	00D 963 0224 707	C,ELECT 2200UF-M/35V	D040222085020S		
	C530-532	00D 963 0021 900	C,FILM 0.047UF-J/100V	D02047306C060S		
	C534,535	00D 963 0234 205	C,ELECT 10UF-M/50V	D040100087070S		
OTHERS PARTS GROUP						
	BKT501	nsp	SHIELD PLATE GND	3070045526010S		
	CLAMP102-105	nsp	CLAMP WIRE(SOLDER)	4330000120000S		
	CN505	nsp	CN.WAFER 7P	L101100030710S		
	CN506	nsp	CN.WAFER 12P	L101100031210S		
	CP501	nsp	CN.WAFER 2CKT,YEL	L108353280290S		
	CP503	nsp	CN.WAFER 2CKT,RED	L108353280280S		
	CP504	nsp	CN.WAFER ST2P	L108202000220S		
	CP505	nsp	CN.WAFER 7P	L101100040710S		
	CP506	nsp	CN.WAFER 12P	L101100041210S		

Ref. No.	Part No.	Part Name	Remarks	Q'ty	New
	CP511	nsp	CN.WAFER 9P	L101220090000S	
	CP513	nsp	CN.WAFER 3P ANGLE	L102526803010S	
	CP514	nsp	CN.WAFER 13P	L101220130000S	
⚠	F501	00D 963 0236 106	FUSE T8A /250V	N751228001110S	
	F501A	nsp	HOLDER,FUSE CLIP	G645000050010S	
	F501B	nsp	HOLDER,FUSE CLIP	G645000050010S	
⚠	F503	00D 963 0236 106	FUSE T8A /250V	N751228001110S	
	F503A	nsp	HOLDER,FUSE CLIP	G645000050010S	
	F503B	nsp	HOLDER,FUSE CLIP	G645000050010S	
	GND501	nsp	TERMINAL EARTH	3790040886000S	
	RLY501	00D 963 0218 205	RELAY HL3-1A-9SH DC9V 1A	G680090102020S	
⚠	SUB501	00D 963 0382 704	SUB TRANS	8200280150400S	
		nsp	HEAT SINK	2120043538050S	
		nsp	HEAT SINK	2120044298010S	
		nsp	SCREW,TAP TITE +2S 3*8 B-TYPE ZNW/BH	B020030081B10S	
		00D 963 0328 409	D,SWITCHING 1N4007	K000400700010S	
⚠		00D 203 3976 002	SOCKET,POWER RECEPTA	G435204004010S	

2CH-AMP P.W.B. UNIT ASS'Y

Ref. No.	Part No.	Part Name	Remarks	Q'ty	New
SEMICONDUCTORS GROUP					
IC401D	00D 960 0159 501	IC KIA7805API	J126780500110S		
IC401H	00D 963 0388 805	CN,WIRE 110MM/3P	L000111030040S		
IC402D	00D 963 0226 608	IC KIA78R33PI	J12678R330010S		
IC402X	00D 963 0366 603	IC KIA1117PI50	J126111750050S		
IC403	00D 263 1223 005	PQ20RX11J00H	J126201100010S		
IC403D	00D 963 0366 706	IC KIA1117PI00	J126111700050S		
Q401SBL	00D 963 0044 204	TR 2SD2390-Y	J5032390Y0000S		
Q401SBR	00D 963 0044 204	TR 2SD2390-Y	J5032390Y0000S		
Q401X	00D 963 0120 801	TR KRC102S	J522010200210S		
Q402D	00D 960 0097 304	TR KRC102M	J6020102M0010S		
Q402SBL	00D 963 0044 107	TR 2SB1560-Y	J5011560Y0000S		
Q402SBR	00D 963 0044 107	TR 2SB1560-Y	J5011560Y0000S		
Q402X	00D 963 0120 801	TR KRC102S	J522010200210S		
Q403SBL	00D 963 0280 107	TR 2SC3964	J502396400000S		
Q403SBR	00D 963 0280 107	TR 2SC3964	J502396400000S		
Q404SBL	00D 960 0196 506	TR KSC1845F	J5021845F0000S		
Q404SBR	00D 960 0196 506	TR KSC1845F	J5021845F0000S		
Q405SBL	00D 273 0459 903	TR KTC2874B	J502287400010S		
Q405SBR	00D 273 0459 903	TR KTC2874B	J502287400010S		
Q406SBL	00D 960 0196 205	TR KSA992F	J5000992F0050S		
Q406SBR	00D 960 0196 205	TR KSA992F	J5000992F0050S		
Q407SBL	00D 960 0196 205	TR KSA992F	J5000992F0050S		
Q407SBR	00D 960 0196 205	TR KSA992F	J5000992F0050S		
Q408SBL	00D 960 0196 506	TR KSC1845F	J5021845F0000S		
Q408SBR	00D 960 0196 506	TR KSC1845F	J5021845F0000S		
Q409D	00D 960 0097 304	TR KRC102M	J6020102M0010S		
D401H	00D 963 0328 409	D,SWITCHING 1N4007	K000400700010S		
D401SBL	00D 963 0341 004	D,SWITCHING KDS4148U	K005041480030S		
D401SBR	00D 963 0341 004	D,SWITCHING KDS4148U	K005041480030S		
D401X	00D 963 0328 409	D,SWITCHING 1N4007	K000400700010S		
D402	00D 276 0401 905	D,SWITCHING 1SS133T	K000013300520S		
D402H	00D 963 0328 409	D,SWITCHING 1N4007	K000400700010S		
D402SBL	00D 963 0341 004	D,SWITCHING KDS4148U	K005041480030S		
D402SBR	00D 963 0341 004	D,SWITCHING KDS4148U	K005041480030S		
D402X	00D 963 0328 409	D,SWITCHING 1N4007	K000400700010S		
D403	00D 276 0401 905	D,SWITCHING 1SS133T	K000013300520S		
ZD401D	00D 960 0095 607	D,ZENER MTZJ5.6B	K06005R644520S		
ZD401SBL	00D 963 0367 008	D,ZENER 0.2W 3.3V UDZ S	K06603R34P400S		
ZD401SBR	00D 963 0367 008	D,ZENER 0.2W 3.3V UDZ S	K06603R34P400S		
ZD402SBL	00D 963 0367 008	D,ZENER 0.2W 3.0V UDZ S	K06603R04P400S		
ZD402SBR	00D 963 0367 008	D,ZENER 0.2W 3.0V UDZ S	K06603R04P400S		
RESISTORS GROUP					
R401D	00D 963 9006 269	R,FIXED 1WJ-0.22	N113135622820S		
R401H	00D 963 9006 269	R,FIXED 1WJ-0.22	N113135622820S		
R401X	00D 963 9006 269	R,FIXED 1WJ-0.22	N113135622820S		
R402D	00D 963 9006 269	R,FIXED 1WJ-0.22	N113135622820S		
R402H	00D 963 9006 269	R,FIXED 1WJ-0.22	N113135622820S		
R402X	00D 963 9006 269	R,FIXED 1WJ-0.22	N113135622820S		
R410SBL	00D 963 9005 642	R,METAL FILM 1.2K-J,1W	C060012265050S		

Ref. No.	Part No.	Part Name	Remarks	Q'ty	New
R410SBR	00D 963 9005 642	R,METAL FILM 1.2K-J,1W	C060012265050S		
R411SBL	00D 960 9010 719	R,METAL FILM 47-J,1W	C060047065060S		
R411SBR	00D 960 9010 719	R,METAL FILM 47-J,1W	C060047065060S		
R414SBL	00D 963 9006 285	R,FIXED 1WJ-5.6K	N113135656220S		
R414SBR	00D 963 9006 285	R,FIXED 1WJ-5.6K	N113135656220S		
R415SBL	00D 963 9006 285	R,FIXED 1WJ-5.6K	N113135656220S		
R415SBR	00D 963 9006 285	R,FIXED 1WJ-5.6K	N113135656220S		
R419SBL	00D 963 0215 907	R,METAL FILM 4.7-J,1W	C0604R7065050S		
R419SBR	00D 963 0215 907	R,METAL FILM 4.7-J,1W	C0604R7065050S		
R420SBL	00D 963 0215 907	R,METAL FILM 4.7-J,1W	C0604R7065050S		
R420SBR	00D 963 0215 907	R,METAL FILM 4.7-J,1W	C0604R7065050S		
R421SBL	00D 963 0345 903	R,FIXED 2WJ-0.47	N113136647820S		
R421SBR	00D 963 0345 903	R,FIXED 2WJ-0.47	N113136647820S		
R422SBL	00D 963 0345 903	R,FIXED 2WJ-0.47	N113136647820S		
R422SBR	00D 963 0345 903	R,FIXED 2WJ-0.47	N113136647820S		
R423SBL	00D 963 0345 903	R,FIXED 2WJ-0.47	N113136647820S		
R423SBR	00D 963 0345 903	R,FIXED 2WJ-0.47	N113136647820S		
R424SBL	00D 963 0345 903	R,FIXED 2WJ-0.47	N113136647820S		
R424SBR	00D 963 0345 903	R,FIXED 2WJ-0.47	N113136647820S		
R429SBL	00D 963 9006 256	R,FIXED 1WJ-10	N113135610020S		
R429SBR	00D 963 9006 256	R,FIXED 1WJ-10	N113135610020S		
R430SBL	00D 963 9006 256	R,FIXED 1WJ-10	N113135610020S		
R430SBR	00D 963 9006 256	R,FIXED 1WJ-10	N113135610020S		
VR401,402	00D 963 0366 407	VR,SEMI CARBON EVN-DCAA03B 1KB	C541102315000S		
CAPACITORS GROUP					
C401D	00D 963 0021 900	C,FILM 0.047UF-J/100V	D02047306C060S		
C401H	00D 963 0021 900	C,FILM 0.047UF-J/100V	D02047306C060S		
C401SBL	00D 963 9006 544	C,ELECT 22UF-M/25V	D040220084050S		
C401SBR	00D 963 9006 544	C,ELECT 22UF-M/25V	D040220084050S		
C401X	nsp	C,CERAMIC 0.1UF-K/50V	D011104577160S		
C402D	00D 963 0021 900	C,FILM 0.047UF-J/100V	D02047306C060S		
C402H	00D 963 0021 900	C,FILM 0.047UF-J/100V	D02047306C060S		
C402SBL	00D 963 0234 205	C,ELECT 10UF-M/50V	D040100087070S		
C402SBR	00D 963 0234 205	C,ELECT 10UF-M/50V	D040100087070S		
C402X	00D 963 9003 097	C,FILM 0.1UF-K/250V	D02010407H080S		
C403D	00D 963 0021 900	C,FILM 0.047UF-J/100V	D02047306C060S		
C403H	00D 963 0021 900	C,FILM 0.047UF-J/100V	D02047306C060S		
C403SBL	00D 963 0367 101	C,CERAMIC 220PF-J/500V	D00422106D05CS		
C403SBR	00D 963 0367 101	C,CERAMIC 220PF-J/500V	D00422106D05CS		
C403X	00D 960 0133 404	C,ELECT 1000UF 16V	D040103083020S		
C404D	00D 960 0133 404	C,ELECT 1000UF 16V	D040103083020S		
C404H	00D 963 0217 002	C,ELECT 3300UF-M/16V	D040332083010S		
C404SBL	00D 963 0338 208	C,CERAMIC 470PF-K/500V	D00447127D050S		
C404SBR	00D 963 0338 208	C,CERAMIC 470PF-K/500V	D00447127D050S		
C404X	00D 963 0276 409	C,ELECT 100UF-M/16V	D040101083090S		
C405D	00D 963 0338 402	C,ELECT 330UF-M/6.3V	D040331081050S		
C405SBL	00D 963 0216 100	C,CERAMIC 33PF-J/500V	D00033006D050S		
C405SBR	00D 963 0216 100	C,CERAMIC 33PF-J/500V	D00033006D050S		
C406D	nsp	C,CERAMIC 0.1UF-K/50V	D011104577160S		
C406SBL	00D 963 0293 709	C,ELECT 100UF-M/10V	D040101082070S		
C406SBR	00D 963 0293 709	C,ELECT 100UF-M/10V	D040101082070S		
C406X	nsp	C,CERAMIC 1000PF-K/50V	D011102777160S		
C407D	nsp	C,CERAMIC 1000PF-K/50V	D011102777160S		

Ref. No.	Part No.	Part Name	Remarks	Q'ty	New
C407SBL	00D 963 9003 194	C,FILM 0.0022UF-J/100V	D02022206C060S		
C407SBR	00D 963 9003 194	C,FILM 0.0022UF-J/100V	D02022206C060S		
C407X	00D 963 0293 709	C,ELECT 100UF-M/10V	D040101082070S		
C408D	00D 963 0338 402	C,ELECT 330UF-M/6.3V	D040331081050S		
C408SBL	00D 963 0234 506	C,ELECT 47UF-M/50V (Pb Free)	D040470087070S		
C408SBR	00D 963 0234 506	C,ELECT 47UF-M/50V (Pb Free)	D040470087070S		
C408X	00D 963 0293 709	C,ELECT 100UF-M/10V	D040101082070S		
C409D	nsp	C,CERAMIC 0.1UF-K/50V	D011104577160S		
C409SBL	00D 963 9003 084	C,CERAMIC 100PF-K/500V	D00410106D050S		
C409SBR	00D 963 9003 084	C,CERAMIC 100PF-K/500V	D00410106D050S		
C410D	00D 963 0338 402	C,ELECT 330UF-M/6.3V	D040331081050S		
C410SBL	00D 963 0234 205	C,ELECT 10UF-M/50V	D040100087070S		
C410SBR	00D 963 0234 205	C,ELECT 10UF-M/50V	D040100087070S		
C411D	nsp	C,CERAMIC 0.1UF-K/50V	D011104577160S		
C411SBL	00D 963 9003 084	C,CERAMIC 100PF-K/500V	D00410106D050S		
C411SBR	00D 963 9003 084	C,CERAMIC 100PF-K/500V	D00410106D050S		
C412D	nsp	C,CERAMIC 0.1UF-K/50V	D011104577160S		
C412SBL	nsp	C,CERAMIC 0.022UF-K/25V	D011223777160S		
C412SBR	nsp	C,CERAMIC 0.022UF-K/25V	D011223777160S		
C413D	00D 963 0024 907	C,ELECT 1000UF-M/6.3V	D040102081060S		
C413SBL	00D 963 9003 097	C,FILM 0.1UF-K/250V	D02010407H080S		
C413SBR	00D 963 9003 097	C,FILM 0.1UF-K/250V	D02010407H080S		
C443	nsp	C,CERAMIC 1000PF-K/50V	D011102777160S		
OTHERS PARTS GROUP					
CLAMP401	nsp	CLAMP WIRE(SOLDER)	4330000120000S		
CN203	nsp	CN,WIRE 160MM/3P	L000161030060S		
CN401A	nsp	CN,WIRE 190MM/5P	L000191050030S		
CN405	nsp	CN,WIRE 5P	L000321050020S		
CN705	nsp	CN,WIRE 150MM/3P	L000151030010S		
CN904	nsp	CN,WIRE 6P	L000141060030S		
CP102	nsp	CN.WAFER 3P	L102526700300S		
CP201	nsp	CN.WAFER 10P	L101220100000S		
CP402	nsp	CN.WAFER 3P	L102526700300S		
L401SBL	nsp	COIL INDUCTOR 0.5UH	D330R50000000S		
L401SBR	nsp	COIL INDUCTOR 0.5UH	D330R50000000S		
TP401,402	nsp	CN.WAFER 3P ANGLE	L101530150310S		
	00D 963 0328 409	D,SWITCHING 1N4007	K000400700010S		

CPU P.W.B. UNIT ASS'Y

Ref. No.	Part No.	Part Name	Remarks	Q'ty	New
SEMICONDUCTORS GROUP					
IC712-715	00D 963 0024 004	IC NJM2068M		J121206800020S	
IC804	963243000020D	IC,CPU MICRO PROCESS	M30626FHPFP	8952150800015	
IC806	00D 960 0100 301	IC KIA7812API		J126781200040S	
IC813	00D 963 0367 204	IC SN74HC151PWR		J040741510070S	
IC817	00D 963 0244 907	IC SN74LV14APWR		J040741400180S	
IC818	00D 963 0367 307	IC SN74AHCU04PWR		J040740400290S	
IC824	00D 963 0043 807	IC BA4510F-E2/SOP8		J121451000010S	
IC827	00D 963 0043 807	IC BA4510F-E2/SOP8		J121451000010S	
IC830	00D 262 2813 903	SN74AHCT08PW-EL2 +C		J040740800190S	
Q704C	00D 963 0044 301	TR KTC2875B(MB)	<div style="border: 1px solid black; border-radius: 15px; padding: 5px; width: fit-content;"> ファームウェアをアップデート するときは、SDIで最終バージョン を確認して下さい。 サービス基板はアップデートし て使用下さい。 When update Firmware, please confirm a last version in SDI. Use the service board after updating it. </div>	J5222875B0010S	
Q704FL	00D 963 0044 301	TR KTC2875B(MB)		J5222875B0010S	
Q704FR	00D 963 0044 301	TR KTC2875B(MB)		J5222875B0010S	
Q704SBL	00D 963 0044 301	TR KTC2875B(MB)		J5222875B0010S	
Q704SBR	00D 963 0044 301	TR KTC2875B(MB)		J5222875B0010S	
Q704SL	00D 963 0044 301	TR KTC2875B(MB)		J5222875B0010S	
Q704SR	00D 963 0044 301	TR KTC2875B(MB)		J5222875B0010S	
Q704SW	00D 963 0044 301	TR KTC2875B(MB)		J5222875B0010S	
Q801	00D 963 0120 704	TR KRA102S	J520010200210S		
Q802-805	00D 963 0044 301	TR KTC2875B(MB)	J5222875B0010S		
Q806	00D 963 0121 509	TR KTC3875S	J522038750210S		
Q807	00D 960 0285 006	TR KRC104S	J522104S00210S		
Q810D	00D 963 0245 100	D,SWITCHING KDS226ST1(C3)	K005022600020S		
Q811D	00D 963 0245 100	D,SWITCHING KDS226ST1(C3)	K005022600020S		
Q812D	00D 963 0120 801	TR KRC102S	J522010200210S		
Q813D	00D 963 0120 704	TR KRA102S	J520010200210S		
D801-804	00D 963 0355 401	D,SWITCHING KDS4148U	K005041480030S		
D805	00D 963 0328 409	D,SWITCHING 1N4007	K000400700010S		
D807	00D 963 0355 401	D,SWITCHING KDS4148U	K005041480030S		
D807D	00D 963 0355 401	D,SWITCHING KDS4148U	K005041480030S		
D808D	00D 963 0341 305	D,ESD IMSA-6802-01A	K067680200010S		
D809D	00D 963 0355 401	D,SWITCHING KDS4148U	K005041480030S		
D810D	00D 963 0341 305	D,ESD IMSA-6802-01A	K067680200010S		
D811D	00D 963 0341 305	D,ESD IMSA-6802-01A	K067680200010S		
ZD801	00D 963 0047 502	D,ZENER MTZJ3.3B	K06003R344520S		
RESISTORS GROUP					
R857	00D 960 9003 807	R,METAL FILM 100-J,1/4W		C060010163050S	
CAPACITORS GROUP					
C751C	00D 963 0234 205	C,ELECT 10UF-M/50V		D040100087070S	
C751FL	00D 963 0234 205	C,ELECT 10UF-M/50V		D040100087070S	
C751FR	00D 963 0234 205	C,ELECT 10UF-M/50V		D040100087070S	
C751SBL	00D 963 0234 205	C,ELECT 10UF-M/50V		D040100087070S	
C751SBR	00D 963 0234 205	C,ELECT 10UF-M/50V		D040100087070S	
C751SL	00D 963 0234 205	C,ELECT 10UF-M/50V		D040100087070S	
C751SR	00D 963 0234 205	C,ELECT 10UF-M/50V		D040100087070S	
C751SW	00D 963 0234 205	C,ELECT 10UF-M/50V		D040100087070S	
C752C	00D 963 0350 503	C,CERAMIC 390PF-J/50V		D010391167160S	
C752FL	00D 963 0223 708	C,CERAMIC 270PF-J/50V		D010271167160S	

Ref. No.	Part No.	Part Name	Remarks	Q'ty	New
C752FR	00D 963 0223 708	C,CERAMIC 270PF-J/50V	D010271167160S		
C752SBL	00D 960 9009 814	C,CERAMIC 330PF-J/50V	D010331167160S		
C752SBR	00D 960 9009 814	C,CERAMIC 330PF-J/50V	D010331167160S		
C752SL	00D 960 9009 814	C,CERAMIC 330PF-J/50V	D010331167160S		
C752SR	00D 960 9009 814	C,CERAMIC 330PF-J/50V	D010331167160S		
C752SW	00D 963 0350 503	C,CERAMIC 390PF-J/50V	D010391167160S		
C753C	00D 963 0224 008	C,CERAMIC 470PF-J/50V	D010471167160S		
C753FL	00D 963 0223 902	C,CERAMIC 39PF-J/50V	D010390167160S		
C753FR	00D 963 0223 902	C,CERAMIC 39PF-J/50V	D010390167160S		
C753SBL	00D 963 0223 708	C,CERAMIC 270PF-J/50V	D010271167160S		
C753SBR	00D 963 0223 708	C,CERAMIC 270PF-J/50V	D010271167160S		
C753SL	00D 963 0223 708	C,CERAMIC 270PF-J/50V	D010271167160S		
C753SR	00D 963 0223 708	C,CERAMIC 270PF-J/50V	D010271167160S		
C753SW	00D 963 0224 008	C,CERAMIC 470PF-J/50V	D010471167160S		
C755C	nsp	C,CERAMIC 0.1UF-Z/50V	D011104597160S		
C755FL	nsp	C,CERAMIC 0.1UF-Z/50V	D011104597160S		
C755FR	nsp	C,CERAMIC 0.1UF-Z/50V	D011104597160S		
C755SBL	nsp	C,CERAMIC 0.1UF-Z/50V	D011104597160S		
C755SBR	nsp	C,CERAMIC 0.1UF-Z/50V	D011104597160S		
C755SL	nsp	C,CERAMIC 0.1UF-Z/50V	D011104597160S		
C755SR	nsp	C,CERAMIC 0.1UF-Z/50V	D011104597160S		
C755SW	nsp	C,CERAMIC 0.1UF-Z/50V	D011104597160S		
C756C	00D 963 9003 194	C,FILM 0.0022UF-J/100V	D02022206C060S		
C756FL	00D 963 9003 194	C,FILM 0.0022UF-J/100V	D02022206C060S		
C756FR	00D 963 9003 194	C,FILM 0.0022UF-J/100V	D02022206C060S		
C756SBL	00D 963 9003 194	C,FILM 0.0022UF-J/100V	D02022206C060S		
C756SBR	00D 963 9003 194	C,FILM 0.0022UF-J/100V	D02022206C060S		
C756SL	00D 963 9003 194	C,FILM 0.0022UF-J/100V	D02022206C060S		
C756SR	00D 963 9003 194	C,FILM 0.0022UF-J/100V	D02022206C060S		
C756SW	00D 963 9003 194	C,FILM 0.0022UF-J/100V	D02022206C060S		
C757C	nsp	C,CERAMIC 10UF-Z/10V	D011106592200S		
C757FL	nsp	C,CERAMIC 10UF-Z/10V	D011106592200S		
C757FR	nsp	C,CERAMIC 10UF-Z/10V	D011106592200S		
C757SBL	nsp	C,CERAMIC 10UF-Z/10V	D011106592200S		
C757SBR	nsp	C,CERAMIC 10UF-Z/10V	D011106592200S		
C757SL	nsp	C,CERAMIC 10UF-Z/10V	D011106592200S		
C757SR	nsp	C,CERAMIC 10UF-Z/10V	D011106592200S		
C757SW	nsp	C,CERAMIC 10UF-Z/10V	D011106592200S		
C803	nsp	C,CERAMIC 100PF-J/50V	D010101167160S		
C804,805	nsp	C,CERAMIC 0.1UF-Z/50V	D011104597160S		
C806	nsp	C,CERAMIC 0.01UF-K/50V	D011103777160S		
C807,808	nsp	C,CERAMIC 0.022UF-Z/50V	D011223597160S		
C809	00D 963 0293 709	C,ELECT 100UF-M/10V	D040101082070S		
C810	nsp	C,CERAMIC 0.1UF-Z/50V	D011104597160S		
C813	nsp	C,CERAMIC 0.1UF-Z/50V	D011104597160S		
C814-816	nsp	C,CERAMIC 0.01UF-K/50V	D011103777160S		
C818	00D 960 9010 010	C,ELECT 4.7UF-M/50V	D0404R7087250S		
C819	nsp	C,CERAMIC 0.01UF-K/50V	D011103777160S		
C824,825	00D 963 0234 205	C,ELECT 10UF-M/50V	D040100087070S		
C826-831	nsp	C,CERAMIC 100PF-J/50V	D010101167160S		
C836,837	nsp	C,CERAMIC 0.022UF-Z/50V	D011223597160S		
C865L	nsp	C,CERAMIC 120PF-J/50V	D010121167160S		
C865R	nsp	C,CERAMIC 120PF-J/50V	D010121167160S		
C871L	00D 963 0216 304	C,FILM 0.001UF-J/100V	D02010206C060S		
C871R	00D 963 0216 304	C,FILM 0.001UF-J/100V	D02010206C060S		
C916D	nsp	C,CERAMIC 0.1UF-Z/50V	D011104597160S		

Ref. No.	Part No.	Part Name	Remarks	Q'ty	New
C917D	nsp	C,CERAMIC 0.1UF-Z/50V	D011104597160S		
C918D	nsp	C,CERAMIC 0.1UF-Z/50V	D011104597160S		
C921D	nsp	C,CERAMIC 100PF-J/50V	D010101167160S		
C923D	nsp	C,CERAMIC 22PF-J/50V	D010220167160S		
C924D	nsp	C,CERAMIC 22PF-J/50V	D010220167160S		
C927D	00D 963 9005 862	C,ELECT 47UF-M/16V	D040470083080S		
C928D	00D 963 9005 862	C,ELECT 47UF-M/16V	D040470083080S		
C931D	nsp	C,CERAMIC 100PF-J/50V	D010101167160S		
C932D	nsp	C,CERAMIC 0.01UF-K/50V	D011103777160S		
C933D	nsp	C,CERAMIC 0.01UF-K/50V	D011103777160S		
C934D	nsp	C,CERAMIC 0.01UF-K/50V	D011103777160S		
C935D	00D 960 9010 010	C,ELECT 4.7UF-M/50V	D0404R7087250S		
C936D	00D 960 9010 010	C,ELECT 4.7UF-M/50V	D0404R7087250S		
C937D	nsp	C,CERAMIC 1000PF-K/50V	D011102777160S		
C938D	00D 960 9010 010	C,ELECT 4.7UF-M/50V	D0404R7087250S		
C939D	nsp	C,CERAMIC 0.01UF-K/50V	D011103777160S		
C940D	nsp	C,CERAMIC 0.01UF-K/50V	D011103777160S		
C941D	00D 963 0244 606	C,ELECT 0.1UF-M/50V (Pb Free)	D040R10087080S		
C950D	nsp	C,CERAMIC 0.1UF-Z/50V	D011104597160S		
C951D	nsp	C,CERAMIC 0.1UF-Z/50V	D011104597160S		
C952D	00D 963 0234 205	C,ELECT 10UF-M/50V	D040100087070S		
C953D	00D 963 0234 205	C,ELECT 10UF-M/50V	D040100087070S		
C954D	nsp	C,CERAMIC 0.1UF-Z/50V	D011104597160S		
C955D	nsp	C,CERAMIC 0.1UF-Z/50V	D011104597160S		
C956D	nsp	C,CERAMIC 22PF-J/50V	D010220167160S		
C957D	nsp	C,CERAMIC 0.1UF-Z/50V	D011104597160S		
C959D	nsp	C,CERAMIC 22PF-J/50V	D010220167160S		
BC801	00D 254 4666 005	CE04W0H105ZC(FG)	D041105090010S		
OTHERS PARTS GROUP					
BD802-809	nsp	COIL,BEAD MB-160808	D340160800060S		
BD809D	nsp	COIL,BEAD MB-160808	D340160800060S		
BD810-817	nsp	COIL,BEAD MB-160808	D340160800060S		
CN106	nsp	CN.WAFER 5P	L101100030510S		
CN108	00D 963 0085 302	CN.WAFER 17P	L101100031710S		
CP01	nsp	CN.WAFER 16P	L101100041610S		
CP301A	00D 963 0367 400	CN.FPC 35P	L131524923520S		
CP701	nsp	CN.WAFER 19P	L101100041910S		
CP702	nsp	CN.WAFER 15P	L100912150010S		
CP703	nsp	CN.WAFER 8P	L101100040810S		
CP801	00D 963 0149 303	CN.FPC 15P	L131111500010S		
CP802	nsp	CN.WAFER 16P	L100912160010S		
CP803	nsp	CN.WAFER 16P	L101100041610S		
CP804	nsp	CN.WAFER 15P	L100912150010S		
CP805	nsp	CN.WAFER 08P	L100912080010S		
CP1001	nsp	CN.WAFER 08P	L101100040810S		
CP1002	nsp	CN.WAFER 9P	L101100040910S		
JACK801	00D 963 0217 905	TER,RCA 2PIN	G601206A0200YS		
JACK802	00D 963 0294 601	JACK,D3.5 EARPHONE	G40100350000YS		
L801D	nsp	COIL INDUCTOR 4.7UH	D3304R7000150S		

Ref. No.	Part No.	Part Name	Remarks	Q'ty	New
L802D	nsp	COIL INDUCTOR 4.7UH	D3304R7000150S		
L803D	nsp	COIL INDUCTOR 4.7UH	D3304R7000150S		
L805D	nsp	COIL INDUCTOR 4.7UH	D3304R7000150S		
L806D	nsp	COIL INDUCTOR 22UH	D330220010050S		
L807D	nsp	COIL INDUCTOR 22UH	D330220010050S		
TP803	nsp	CN.WAFER 8P	L101220080000S		
TP804	nsp	CN.WAFER 4P	L101220040000S		
X801	00D 963 0217 701	RESONATOR,CERAMIC ZTT12.00MT	E830120000060S		
OPT801D	00D 963 0237 503	MODULE JSR1165-C	E100116500040S		
OPT802D	00D 963 0237 503	MODULE JSR1165-C	E100116500040S		
	nsp	CN,WIRE 110MM/1P	L000111010010S		

HDMI P.W.B. UNIT ASS'Y

Ref. No.	Part No.	Part Name	Remarks	Q'ty	New
SEMICONDUCTORS GROUP					
IC01	nsp	SII9185CTU	00D2623721007		
IC03	nsp	IC SE1117-1.8	J126111718010S		
IC04	nsp	IC F2621E-01-PR	J080260200040S		
IC05	nsp	IC SE1117-33-PF	J126111733020S		
IC06	nsp	IC AK4385	J042438500010S		
IC07	nsp	SN74LV08APW-EL2 +REF	00D2622517908		
IC08,09	nsp	SN74AHCT08PW-EL2 +C	00D2622813903		
IC10	nsp	IC NJM2068M	J121206800020S		
IC11	nsp	IC KIA1117PI50	J126111750050S		
IC12	nsp	IC BU4094BCF-E2	J040140940030S		
IC801	nsp	ADSP21367KSZ1A1136	00D2623709016		
IC802	nsp	W9864G2GH-7	00D2623746008		
IC803	nsp	IC EN29LV160T-70TCP	J005291600010S		
IC807	nsp	LC89057W-VF4A	00D2623449004		
IC808	nsp	ADAU1328BSTZ1136	00D2623645015		
IC809-811	nsp	IC SN74LVC244APWR	J040742440230S		
IC812	nsp	IC SN74HCT244PWR	J040742440220S		
IC814,815	nsp	IC SN74HCT00PWR	J040740000210S		
IC816	nsp	74LVX157MTC +C	00D2622870904		
IC823	nsp	IC KIA7805API	J126780500110S		
IC825,826	nsp	IC SN74LVC74APWR	J040747400200S		
IC832	nsp	IC SE1117-33-PF	J126111733020S		
Q01,02	nsp	TR KRC102S	J522010200210S		
Q03,04	nsp	TR KRC104S	J522104S00210S		
Q05	nsp	TR KRA102S	J520010200210S		
Q06	nsp	TR KTC3875S	J522038750210S		
Q07	nsp	TR KRC104S	J522104S00210S		
Q08	nsp	TR KRC102S	J522010200210S		
Q09	nsp	TR KRA104S	J520010400210S		
Q10,11	nsp	TR KRC102S	J522010200210S		
Q12,13	nsp	TR KRA102S	J520010200210S		
Q14-17	nsp	TR KTC2875B(MB)	J5222875B0010S		
Q810D	nsp	TR KRC102S	J522010200210S		
Q811D	nsp	TR KRA102S	J520010200210S		
Q814D	nsp	TR KRA102S	J520010200210S		
D01-36	nsp	D,ESD IMSA-6802-01A	K067680200010S		
D37-44	nsp	D,SWITCHING KDS4148U	K005041480030S		
RESISTORS GROUP					
R41,42	nsp	COIL,BEAD MB-160808	D340160800060S		
R62	nsp	COIL,BEAD MB-160808	D340160800060S		
CAPACITORS GROUP					
C01	nsp	C,CERAMIC 1000PF-K/50V	D011102777160S		
C02-05	nsp	C,CERAMIC 0.1UF-K/50V	D011104577162S		
C06,07	nsp	C,CERAMIC 1000PF-K/50V	D011102777160S		
C08-14	nsp	C,CERAMIC 0.1UF-K/50V	D011104577162S		
C15-17	nsp	C,CERAMIC 1000PF-K/50V	D011102777160S		
C18,19	nsp	C,CERAMIC 0.1UF-K/50V	D011104577162S		
C20	nsp	C,CERAMIC 1000PF-K/50V	D011102777160S		

Ref. No.	Part No.	Part Name	Remarks	Q'ty	New
C21	nsp	C,CERAMIC 100PF-J/50V	D010101167160S		
C22	nsp	C,CERAMIC 1000PF-K/50V	D011102777160S		
C23	nsp	C,CERAMIC 100PF-J/50V	D010101167160S		
C24,25	nsp	C,ELECT 10UF-MVG/16V	D050100083460S		
C26,27	nsp	C,CERAMIC 0.01UF-K/50V	D011103777160S		
C28H	nsp	C,ELECT 10UF-MVG/16V	D050100083460S		
C29	nsp	C,CERAMIC 0.1UF-K/50V	D011104577162S		
C29H	nsp	C,ELECT 10UF-MVG/16V	D050100083460S		
C30	nsp	C,CERAMIC 0.1UF-K/50V	D011104577162S		
C30H	nsp	C,ELECT 10UF-MVG/16V	D050100083460S		
C31,32	nsp	C,CERAMIC 0.1UF-K/50V	D011104577162S		
C33-36	nsp	C,CERAMIC 20PF-J/50V	D010200167160S		
C37-39	nsp	C,CERAMIC 0.1UF-K/50V	D011104577162S		
C40	nsp	C,ELECT 22UF-MV/6.3V	D050220081450S		
C41	nsp	C,CERAMIC 0.1UF-K/50V	D011104577162S		
C42,43	nsp	C,CERAMIC 5PF-C/50V	D010050107160S		
C44	nsp	C,CERAMIC 0.1UF-K/50V	D011104577162S		
C45	nsp	C,CERAMIC 1000PF-K/50V	D011102777160S		
C46	nsp	C,CERAMIC 4.7UF-K/10V	D011475572200S		
C47-50	nsp	C,CERAMIC 0.1UF-K/50V	D011104577162S		
C51	nsp	C,CERAMIC 1000PF-K/50V	D011102777160S		
C52	nsp	C,CERAMIC 0.1UF-K/50V	D011104577162S		
C53	nsp	C,ELECT 10UF-MVG/16V	D050100083460S		
C54	nsp	C,CERAMIC 0.1UF-K/50V	D011104577162S		
C55	nsp	C,CERAMIC 4.7UF-K/10V	D011475572200S		
C56,57	nsp	C,CERAMIC 1000PF-K/50V	D011102777160S		
C58	nsp	C,CERAMIC 0.1UF-K/50V	D011104577162S		
C59	nsp	C,CERAMIC 1000PF-K/50V	D011102777160S		
C60	nsp	C,CERAMIC 0.1UF-K/50V	D011104577162S		
C61	nsp	C,CERAMIC 1000PF-K/50V	D011102777160S		
C62	nsp	C,CERAMIC 0.1UF-K/50V	D011104577162S		
C63-65	nsp	C,CERAMIC 100PF-J/50V	D010101167160S		
C66	nsp	C,CERAMIC 0.01UF-K/50V	D011103777160S		
C68	nsp	C,ELECT 0.1UF-MVG/50V	D050R10080010S		
C69,70	nsp	C,CERAMIC 0.1UF-K/50V	D011104577162S		
C71,72	nsp	C,ELECT 22UF-MV/6.3V	D050220081450S		
C73,74	nsp	C,ELECT 10UF-MVG/16V	D050100083460S		
C75	nsp	C,CERAMIC 560PF-J/50V	D010561167160S		
C76	nsp	C,CERAMIC 1800PF-K/50V	D011182777160S		
C77,78	nsp	C,CERAMIC 560PF-J/50V	D010561167160S		
C79	nsp	C,CERAMIC 1800PF-K/50V	D011182777160S		
C80	nsp	C,CERAMIC 560PF-J/50V	D010561167160S		
C82	nsp	C,CERAMIC 1000PF-K/50V	D011102777160S		
C831D	nsp	C,CERAMIC 0.1UF-K/50V	D011104577162S		
C832D	nsp	C,CERAMIC 1000PF-K/50V	D011102177101S		
C833D	nsp	C,CERAMIC 100PF-J/50V	D011101167101S		
C834D	nsp	C,CERAMIC 100PF-J/50V	D011101167101S		
C835D	nsp	C,CERAMIC 0.01UF-K/50V	D011103177101S		
C836D	nsp	C,CERAMIC 0.01UF-K/50V	D011103177101S		
C837D	nsp	C,CERAMIC 100PF-J/50V	D011101167101S		
C838D	nsp	C,CERAMIC 100PF-J/50V	D011101167101S		
C839D	nsp	C,CERAMIC 100PF-J/50V	D011101167101S		
C840D	nsp	C,CERAMIC 100PF-J/50V	D011101167101S		
C841D	nsp	C,CERAMIC 100PF-J/50V	D011101167101S		
C842D	nsp	C,CERAMIC 100PF-J/50V	D011101167101S		
C843D	nsp	C,CERAMIC 100PF-J/50V	D011101167101S		

Ref. No.	Part No.	Part Name	Remarks	Q'ty	New
C844D	nsp	C,CERAMIC 100PF-J/50V	D011101167101S		
C845D	nsp	C,CERAMIC 0.1UF-K/50V	D011104177101S		
C846D	nsp	C,CERAMIC 1000PF-K/50V	D011102177101S		
C847D	nsp	C,CERAMIC 1000PF-K/50V	D011102177101S		
C848D	nsp	C,CERAMIC 1000PF-K/50V	D011102177101S		
C849D	nsp	C,CERAMIC 1000PF-K/50V	D011102177101S		
C850D	nsp	C,CERAMIC 1000PF-K/50V	D011102177101S		
C851D	nsp	C,CERAMIC 1000PF-K/50V	D011102177101S		
C852D	nsp	C,CERAMIC 1000PF-K/50V	D011102177101S		
C853D	nsp	C,CERAMIC 1000PF-K/50V	D011102177101S		
C854D	nsp	C,CERAMIC 0.1UF-K/50V	D011104177101S		
C855D	nsp	C,CERAMIC 0.1UF-K/50V	D011104177101S		
C856D	nsp	C,CERAMIC 0.1UF-K/50V	D011104177101S		
C857D	nsp	C,CERAMIC 0.1UF-K/50V	D011104177101S		
C858D	nsp	C,CERAMIC 0.1UF-K/50V	D011104177101S		
C859D	nsp	C,CERAMIC 0.1UF-K/50V	D011104177101S		
C860D	nsp	C,CERAMIC 0.1UF-K/50V	D011104177101S		
C861D	nsp	C,CERAMIC 0.1UF-K/50V	D011104177101S		
C862D	nsp	C,CERAMIC 0.01UF-K/50V	D011103177101S		
C863D	nsp	C,CERAMIC 100PF-J/50V	D011101167101S		
C864D	nsp	C,CERAMIC 4.7UF-K/10V	D011475572200S		
C865D	nsp	C,CERAMIC 5PF-C/50V	D010050107160S		
C866D	nsp	C,CERAMIC 5PF-C/50V	D010050107160S		
C871D	nsp	C,CERAMIC 0.01UF-K/50V	D011103177101S		
C873D	nsp	C,CERAMIC 0.01UF-K/50V	D011103177101S		
C875D	nsp	C,CERAMIC 4.7UF-K/10V	D011475572200S		
C876D	nsp	C,CERAMIC 0.01UF-K/50V	D011103177101S		
C877D	nsp	C,CERAMIC 0.1UF-K/50V	D011104177101S		
C878D	nsp	C,CERAMIC 0.1UF-K/50V	D011104177101S		
C879D	nsp	C,CERAMIC 0.1UF-K/50V	D011104177101S		
C880D	nsp	C,CERAMIC 0.01UF-K/50V	D011103177101S		
C881D	nsp	C,CERAMIC 0.01UF-K/50V	D011103177101S		
C882D	nsp	C,CERAMIC 6PF-D/50V	D010060117160S		
C883D	nsp	C,CERAMIC 6PF-D/50V	D010060117160S		
C884D	nsp	C,CERAMIC 0.1UF-K/50V	D011104577162S		
C885D	nsp	C,CERAMIC 0.022UF-Z/50V	D011223597160S		
C886D	nsp	C,CERAMIC 0.1UF-K/50V	D011104177101S		
C887D	nsp	C,FILM 0.12UF-J/63V	D020124078060S		
C888D	nsp	C,CERAMIC 0.01UF-K/50V	D011103177101S		
C889D	nsp	C,CERAMIC 100PF-J/50V	D011101167101S		
C890D	nsp	C,CERAMIC 0.01UF-K/50V	D011103177101S		
C891D	nsp	C,CERAMIC 0.01UF-K/50V	D011103177101S		
C892D	nsp	C,CERAMIC 4.7UF-K/10V	D011475572200S		
C893D	nsp	C,CERAMIC 0.1UF-K/50V	D011104177101S		
C895D	nsp	C,CERAMIC 0.1UF-K/50V	D011104177101S		
C896D	nsp	C,CERAMIC 0.01UF-K/50V	D011103177101S		
C897D	nsp	C,CERAMIC 0.1UF-K/50V	D011104177101S		
C898D	nsp	C,CERAMIC 0.1UF-K/50V	D011104177101S		
C899D	nsp	C,CERAMIC 100PF-J/50V	D011101167101S		
C900D	nsp	C,CERAMIC 4.7UF-K/10V	D011475572200S		
C901D	nsp	C,ELECT 100UF-MVG/6.3V	D050101081650S		
C902D	nsp	C,CERAMIC 0.1UF-K/50V	D011104177101S		
C903D	nsp	C,CERAMIC 0.1UF-K/50V	D011104177101S		
C904D	nsp	C,CERAMIC 5600PF-K/50V	D011562777160S		
C905D	nsp	C,CERAMIC 390PF-J/50V	D010391167160S		
C906D	nsp	C,CERAMIC 0.1UF-K/50V	D011104177101S		

Ref. No.	Part No.	Part Name	Remarks	Q'ty	New
C907D	nsp	C,CERAMIC 0.1UF-K/50V	D011104177101S		
C908D	nsp	C,ELECT 47UF-MVG/6.3V	D050470081460S		
C909D	nsp	C,CERAMIC 0.1UF-K/50V	D011104177101S		
C910D	nsp	C,ELECT 10UF-MVG/16V	D050100083460S		
C911D	nsp	C,CERAMIC 0.01UF-K/50V	D011103177101S		
C913D	nsp	C,ELECT 10UF-MVG/16V	D050100083460S		
C914D	nsp	C,CERAMIC 0.01UF-K/50V	D011103177101S		
C915D	nsp	C,ELECT 10UF-MVG/16V	D050100083460S		
OTHERS PARTS GROUP					
BD801	nsp	COIL,BEAD MB-160808	D340160800060S		
BD807D	nsp	COIL,BEAD MB-160808	D340160800060S		
BD808D-03	nsp	COIL,BEAD MB-160808	D340160800060S		
CB06	nsp	COIL,BEAD MB-160808	D340160800060S		
CN01	nsp	CN.WAFER 16P	L101100031610S		
CN802	nsp	CN.HOUSING 16P	L120912160010S		
CN803	nsp	CN.WAFER 16P	L101100031610S		
CN804	nsp	CN.HOUSING 15P	L120912150010S		
CN805	nsp	CN.HOUSING 08P	L120912080010S		
CP201	nsp	CN.WAFER 9P	L101220090000S		
CP404	nsp	CN.WAFER 4P	L101220040000S		
CP405	nsp	CN.WAFER 5P	L101220050000S		
CP904	nsp	CN.WAFER 6P	L101220060010S		
J806	nsp	R,CHIP THICK 0-J,1/16W	C20000006M101S		
JACK01-03	00D 963 0388 504	19PIN HDMI CONNECTOR	L109100190020S		
JACK04	nsp	CAM-D96 4PIN SMALL COCNNETOR	L109040000020S		
TP801	nsp	CN.WAFER 13P	L101530141310S		
X01	nsp	FCX-02(45.1584MHz)	00D3991055912		
X803D	nsp	FCX-03(16.660MHz)	00D3991091905		
X804D	nsp	FCX-03(24.576MHz)	00D3991053901		

VIDEO P.W.B. UNIT ASS'Y

Ref. No.	Part No.	Part Name	Remarks	Q'ty	New
SEMICONDUCTORS GROUP					
IC1301	00D 960 0175 200	IC BA7625		J171762500000S	
IC1302,1303	00D 963 0083 304	IC BA7626		J171762600000S	
IC1304	00D 960 0239 104	IC KIA7806API		J126780600130S	
IC1305-1307	00D 963 0148 401	IC LA7956		J171795600010S	
Q1301-1303	00D 960 0005 105	TR KTA1266Y		J5001266Y0050S	
Q1304,1305	00D 960 0005 202	TR KTC3198Y		J5023198Y0000S	
Q1306-1309	00D 963 0121 208	TR KRC107M		J6020107M0010S	
Q1310-1313	00D 960 0005 202	TR KTC3198Y		J5023198Y0000S	
Q1314-1317	00D 963 0121 208	TR KRC107M		J6020107M0010S	
D1301	00D 963 0355 401	D,SWITCHING KDS4148U		K005041480030S	
D1302-1305	00D 276 0401 905	D,SWITCHING 1SS133T		K000013300520S	
D1306,1307	00D 963 0355 401	D,SWITCHING KDS4148U		K005041480030S	
CAPACITORS GROUP					
C1301-1309	00D 960 9010 010	C,ELECT 4.7UF-M/50V		D0404R7087250S	
C1310	00D 963 9005 969	C,ELECT 4700UF-M/6.3V		D040472081000S	
C1311,1312	00D 960 0298 802	C,ELECT 470UF-M/6.3V		D040471081070S	
C1313-1315	00D 963 0311 607	C,ELECT 100UF-M/10V (Pb Free)		D040101082090S	
C1316-1321	00D 963 0293 602	C,ELECT 1UF-M/50V (Pb Free)		D040010087150S	
C1322	nsp	C,CERAMIC 0.022UF-K/25V		D011223777160S	
C1323	00D 963 0311 607	C,ELECT 100UF-M/10V (Pb Free)		D040101082090S	
C1324	nsp	C,CERAMIC 0.022UF-K/25V		D011223777160S	
C1326	nsp	C,CERAMIC 0.022UF-K/25V		D011223777160S	
C1328	00D 963 0234 205	C,ELECT 10UF-M/50V		D040100087070S	
C1329	00D 963 0234 506	C,ELECT 47UF-M/50V (Pb Free)		D040470087070S	
C1330	00D 963 0234 205	C,ELECT 10UF-M/50V		D040100087070S	
C1331-1339	00D 963 9005 862	C,ELECT 47UF-M/16V		D040470083080S	
C1340-1345	00D 963 9005 901	C,ELECT 470UF-M/10V,6.3*11		D040471082060S	
C1347	nsp	C,CERAMIC 0.047UF-Z/50V		D011473597160S	
C1348	00D 960 9009 924	C,ELECT 100UF-M/16V		D040101083070S	
C1349,1350	nsp	C,CERAMIC 0.047UF-Z/50V		D011473597160S	
C1351,1352	00D 963 0293 602	C,ELECT 1UF-M/50V (Pb Free)		D040010087150S	
OTHERS PARTS GROUP					
CN406	nsp	CN,WIRE 300MM/3P		L000301030060S	
CN1301	nsp	CN.WAFER 5P		L101220050010S	
CN1303	nsp	CN.WAFER 8P		L101100030810S	
CP1302	nsp	CN.WAFER 9P		L101100030910S	
JACK1301	00D 963 0218 001	TER,RCA 2PIN		G60122001000YS	
JACK1302	00D 963 0218 108	TER,RCA 3PIN		G60630401000YS	
JACK1303,1304	00D 963 0367 709	TER,RCA 6PIN		G603610D0032YS	
	nsp	HEAT SINK		2120044338010S	
	nsp	SCREW,TAP TITE +2S 3*8 B-TYPE ZNW/BH		B020030081B10S	

HDMI_PWR P.W.B. UNIT ASS'Y

Ref. No.	Part No.	Part Name	Remarks	Q'ty	New
SEMICONDUCTORS GROUP					
IC401H1	00D 963 0366 500	IC KIA1117PI33		J126111733050S	
CAPACITORS GROUP					
C405H1	00D 963 0234 205	C,ELECT 10UF-M/50V		D040100087070S	
C406H1	00D 963 0233 303	C,CERAMIC 0.01UF-M/16V		D005103773530S	
OTHERS PARTS GROUP					
CN404	nsp	CN,WIRE 300MM/4P		L000301040110S	
CP513	nsp	CN.WAFER 3P ANGLE		L102526803010S	

PARTS LIST OF P.W.B. UNIT



AVR-1508 E2 MODEL

* 本表に "nsp" と記載されている部品は供給できません。

* Parts for which "nsp" is indicated on this table cannot be supplied.

* 本表に記載されている部品は、補修用部品のため製品に使用している部品とは一部、形状、寸法などが異なる場合があります。

* The parts listed below are for maintenance only, might differ from the parts used in the unit in appearances or dimensions.

MAIN P.W.B. UNIT ASS'Y

Ref. No.	Part No.	Part Name	Remarks	Q'ty	New
SEMICONDUCTORS GROUP					
IC110,111	00D 963 0218 807	IC BU4094BCF-E2	J040140940030S		
Q101	00D 960 0196 302	TR KTA1268BL	J5001268B0050S		
Q102-104	00D 960 0196 700	TR KTC3200BL	J5023200B0050S		
Q104C	00D 960 0196 506	TR KSC1845F	J5021845F0000S		
Q104FL	00D 960 0196 506	TR KSC1845F	J5021845F0000S		
Q104FR	00D 960 0196 506	TR KSC1845F	J5021845F0000S		
Q104SL	00D 960 0196 506	TR KSC1845F	J5021845F0000S		
Q104SR	00D 960 0196 506	TR KSC1845F	J5021845F0000S		
Q105	00D 960 0196 700	TR KTC3200BL	J5023200B0050S		
Q105C	00D 960 0196 603	TR KTC2874B	J502287400010S		
Q105FL	00D 960 0196 603	TR KTC2874B	J502287400010S		
Q105FR	00D 960 0196 603	TR KTC2874B	J502287400010S		
Q105SL	00D 960 0196 603	TR KTC2874B	J502287400010S		
Q105SR	00D 960 0196 603	TR KTC2874B	J502287400010S		
Q106	00D 960 0196 700	TR KTC3200BL	J5023200B0050S		
Q106C	00D 960 0196 205	TR KSA992F	J5000992F0050S		
Q106FL	00D 960 0196 205	TR KSA992F	J5000992F0050S		
Q106FR	00D 960 0196 205	TR KSA992F	J5000992F0050S		
Q106SL	00D 960 0196 205	TR KSA992F	J5000992F0050S		
Q106SR	00D 960 0196 205	TR KSA992F	J5000992F0050S		
Q107	00D 960 0196 700	TR KTC3200BL	J5023200B0050S		
Q107C	00D 960 0196 205	TR KSA992F	J5000992F0050S		
Q107FL	00D 960 0196 205	TR KSA992F	J5000992F0050S		
Q107FR	00D 960 0196 205	TR KSA992F	J5000992F0050S		
Q107SL	00D 960 0196 205	TR KSA992F	J5000992F0050S		
Q107SR	00D 960 0196 205	TR KSA992F	J5000992F0050S		
Q108	00D 960 0196 700	TR KTC3200BL	J5023200B0050S		
Q108C	00D 960 0196 506	TR KSC1845F	J5021845F0000S		
Q108FL	00D 960 0196 506	TR KSC1845F	J5021845F0000S		
Q108FR	00D 960 0196 506	TR KSC1845F	J5021845F0000S		
Q108SL	00D 960 0196 506	TR KSC1845F	J5021845F0000S		
Q108SR	00D 960 0196 506	TR KSC1845F	J5021845F0000S		
Q109,110	00D 960 0196 700	TR KTC3200BL	J5023200B0050S		
Q111	00D 960 0196 302	TR KTA1268BL	J5001268B0050S		
Q130	00D 960 0196 302	TR KTA1268BL	J5001268B0050S		
Q131,132	00D 963 0219 602	TR KRC106M	J6020106M0010S		
Q133-137	00D 960 0097 207	TR KRA102M	J6002202M0010S		
Q141SW	00D 963 0044 301	TR KTC2875B(MB)	J5222875B0010S		
Q142	00D 960 0196 700	TR KTC3200BL	J5023200B0050S		
Q142SW	00D 963 0044 301	TR KTC2875B(MB)	J5222875B0010S		
Q143,144	00D 960 0196 302	TR KTA1268BL	J5001268B0050S		
Q145	00D 960 0196 700	TR KTC3200BL	J5023200B0050S		
Q146,147	00D 960 0196 302	TR KTA1268BL	J5001268B0050S		
Q151	00D 960 0196 302	TR KTA1268BL	J5001268B0050S		
Q156	00D 960 0097 304	TR KRC102M	J6020102M0010S		
Q165	00D 960 0196 700	TR KTC3200BL	J5023200B0050S		
Q166-171	00D 960 0196 302	TR KTA1268BL	J5001268B0050S		

Ref. No.	Part No.	Part Name	Remarks	Q'ty	New
Q541	00D 963 0121 208	TR KRC107M	J6020107M0010S		
D101C	00D 963 0355 401	D,SWITCHING KDS4148U	K005041480030S		
D101FL	00D 963 0355 401	D,SWITCHING KDS4148U	K005041480030S		
D101FR	00D 963 0355 401	D,SWITCHING KDS4148U	K005041480030S		
D101SL	00D 963 0355 401	D,SWITCHING KDS4148U	K005041480030S		
D101SR	00D 963 0355 401	D,SWITCHING KDS4148U	K005041480030S		
D102C	00D 963 0355 401	D,SWITCHING KDS4148U	K005041480030S		
D102FL	00D 963 0355 401	D,SWITCHING KDS4148U	K005041480030S		
D102FR	00D 963 0355 401	D,SWITCHING KDS4148U	K005041480030S		
D102SL	00D 963 0355 401	D,SWITCHING KDS4148U	K005041480030S		
D102SR	00D 963 0355 401	D,SWITCHING KDS4148U	K005041480030S		
D105C	00D 963 0020 309	D,SWITCHING 1SS133T	K000013300520S		
D105FL	00D 963 0020 309	D,SWITCHING 1SS133T	K000013300520S		
D105FR	00D 963 0020 309	D,SWITCHING 1SS133T	K000013300520S		
D105SL	00D 963 0020 309	D,SWITCHING 1SS133T	K000013300520S		
D105SR	00D 963 0020 309	D,SWITCHING 1SS133T	K000013300520S		
D106,107	00D 963 0355 401	D,SWITCHING KDS4148U	K005041480030S		
D114,115	00D 960 0197 107	D,RECTIFIER BRIDGE KBPC604	K047604000020S		
D139	00D 963 0020 309	D,SWITCHING 1SS133T	K000013300520S		
D140,141	00D 963 0328 409	D,SWITCHING 1N4007	K000400700010S		
D142	00D 963 0355 401	D,SWITCHING KDS4148U	K005041480030S		
D143-152	00D 963 0020 309	D,SWITCHING 1SS133T	K000013300520S		
D153	00D 963 0355 401	D,SWITCHING KDS4148U	K005041480030S		
D154-157	00D 963 0020 309	D,SWITCHING 1SS133T	K000013300520S		
D541	00D 963 0355 401	D,SWITCHING KDS4148U	K005041480030S		
ZD101	00D 963 0058 601	D,ZENER MTZJ12B	K06012R044520S		
ZD101C	00D 963 0367 008	D,ZENER 0.2W 3.3V UDZ	K06603R34P400S		
ZD101FL	00D 963 0367 008	D,ZENER 0.2W 3.3V UDZ	K06603R34P400S		
ZD101FR	00D 963 0367 008	D,ZENER 0.2W 3.3V UDZ	K06603R34P400S		
ZD101SL	00D 963 0367 008	D,ZENER 0.2W 3.3V UDZ	K06603R34P400S		
ZD101SR	00D 963 0367 008	D,ZENER 0.2W 3.3V UDZ	K06603R34P400S		
ZD102C	00D 963 0367 008	D,ZENER 0.2W 3.3V UDZ	K06603R04P400S		
ZD102FL	00D 963 0367 008	D,ZENER 0.2W 3.3V UDZ	K06603R04P400S		
ZD102FR	00D 963 0367 008	D,ZENER 0.2W 3.3V UDZ	K06603R04P400S		
ZD102SL	00D 963 0367 008	D,ZENER 0.2W 3.3V UDZ	K06603R04P400S		
ZD102SR	00D 963 0367 008	D,ZENER 0.2W 3.3V UDZ	K06603R04P400S		
ZD105	00D 960 0095 500	D,ZENER MTZJ5.1B	K06005R144520S		
RESISTORS GROUP					
R101	00D 963 0337 801	R,METAL FILM 100-J,2W	C060010166520S		
R103	00D 963 9005 639	R,METAL FILM 100-J,1W	C060010165060S		
R104	00D 963 0215 907	R,METAL FILM 4.7-J,1W	C0604R7065050S		
R104C	00D 963 9006 285	R,FIXED 1WJ-5.6K	N113135656220S		
R104FL	00D 963 9006 285	R,FIXED 1WJ-5.6K	N113135656220S		
R104FR	00D 963 9006 285	R,FIXED 1WJ-5.6K	N113135656220S		
R104SL	00D 963 9006 285	R,FIXED 1WJ-5.6K	N113135656220S		
R104SR	00D 963 9006 285	R,FIXED 1WJ-5.6K	N113135656220S		
R105	00D 963 0232 906	R,METAL FILM 47K-F,1/4W	C060047343530S		
R105C	00D 963 9006 285	R,FIXED 1WJ-5.6K	N113135656220S		
R105FL	00D 963 9006 285	R,FIXED 1WJ-5.6K	N113135656220S		
R105FR	00D 963 9006 285	R,FIXED 1WJ-5.6K	N113135656220S		
R105SL	00D 963 9006 285	R,FIXED 1WJ-5.6K	N113135656220S		
R105SR	00D 963 9006 285	R,FIXED 1WJ-5.6K	N113135656220S		

Ref. No.	Part No.	Part Name	Remarks	Q'ty	New
R106C	00D 963 0215 907	R,METAL FILM 4.7-J,1W	C0604R7065050S		
R106FL	00D 963 0215 907	R,METAL FILM 4.7-J,1W	C0604R7065050S		
R106FR	00D 963 0215 907	R,METAL FILM 4.7-J,1W	C0604R7065050S		
R106SL	00D 963 0215 907	R,METAL FILM 4.7-J,1W	C0604R7065050S		
R106SR	00D 963 0215 907	R,METAL FILM 4.7-J,1W	C0604R7065050S		
R107C	00D 963 0215 907	R,METAL FILM 4.7-J,1W	C0604R7065050S		
R107FL	00D 963 0215 907	R,METAL FILM 4.7-J,1W	C0604R7065050S		
R107FR	00D 963 0215 907	R,METAL FILM 4.7-J,1W	C0604R7065050S		
R107SL	00D 963 0215 907	R,METAL FILM 4.7-J,1W	C0604R7065050S		
R107SR	00D 963 0215 907	R,METAL FILM 4.7-J,1W	C0604R7065050S		
R108C	00D 963 0345 903	R,FIXED 2WJ-0.47	N113136647820S		
R108FL	00D 963 0345 903	R,FIXED 2WJ-0.47	N113136647820S		
R108FR	00D 963 0345 903	R,FIXED 2WJ-0.47	N113136647820S		
R108SL	00D 963 0345 903	R,FIXED 2WJ-0.47	N113136647820S		
R108SR	00D 963 0345 903	R,FIXED 2WJ-0.47	N113136647820S		
R109C	00D 963 0345 903	R,FIXED 2WJ-0.47	N113136647820S		
R109FL	00D 963 0345 903	R,FIXED 2WJ-0.47	N113136647820S		
R109FR	00D 963 0345 903	R,FIXED 2WJ-0.47	N113136647820S		
R109SL	00D 963 0345 903	R,FIXED 2WJ-0.47	N113136647820S		
R109SR	00D 963 0345 903	R,FIXED 2WJ-0.47	N113136647820S		
R110C	00D 963 0345 903	R,FIXED 2WJ-0.47	N113136647820S		
R110FL	00D 963 0345 903	R,FIXED 2WJ-0.47	N113136647820S		
R110FR	00D 963 0345 903	R,FIXED 2WJ-0.47	N113136647820S		
R110SL	00D 963 0345 903	R,FIXED 2WJ-0.47	N113136647820S		
R110SR	00D 963 0345 903	R,FIXED 2WJ-0.47	N113136647820S		
R111C	00D 963 0345 903	R,FIXED 2WJ-0.47	N113136647820S		
R111FL	00D 963 0345 903	R,FIXED 2WJ-0.47	N113136647820S		
R111FR	00D 963 0345 903	R,FIXED 2WJ-0.47	N113136647820S		
R111SL	00D 963 0345 903	R,FIXED 2WJ-0.47	N113136647820S		
R111SR	00D 963 0345 903	R,FIXED 2WJ-0.47	N113136647820S		
R117,118	00D 963 0144 502	R,CEMENT 0.1-J 5W	C141R10069000S		
R118C	00D 963 9006 256	R,FIXED 1WJ-10	N113135610020S		
R118FL	00D 963 9006 256	R,FIXED 1WJ-10	N113135610020S		
R118FR	00D 963 9006 256	R,FIXED 1WJ-10	N113135610020S		
R118SL	00D 963 9006 256	R,FIXED 1WJ-10	N113135610020S		
R118SR	00D 963 9006 256	R,FIXED 1WJ-10	N113135610020S		
R119C	00D 963 9006 256	R,FIXED 1WJ-10	N113135610020S		
R119FL	00D 963 9006 256	R,FIXED 1WJ-10	N113135610020S		
R119FR	00D 963 9006 256	R,FIXED 1WJ-10	N113135610020S		
R119SL	00D 963 9006 256	R,FIXED 1WJ-10	N113135610020S		
R119SR	00D 963 9006 256	R,FIXED 1WJ-10	N113135610020S		
R127C	00D 963 9005 642	R,METAL FILM 1.2K-J,1W	C060012265050S		
R127FL	00D 963 9005 642	R,METAL FILM 1.2K-J,1W	C060012265050S		
R127FR	00D 963 9005 642	R,METAL FILM 1.2K-J,1W	C060012265050S		
R127SL	00D 963 9005 642	R,METAL FILM 1.2K-J,1W	C060012265050S		
R127SR	00D 963 9005 642	R,METAL FILM 1.2K-J,1W	C060012265050S		
R132C	00D 960 9010 719	R,METAL FILM 47-J,1W	C060047065060S		
R132FL	00D 960 9010 719	R,METAL FILM 47-J,1W	C060047065060S		
R132FR	00D 960 9010 719	R,METAL FILM 47-J,1W	C060047065060S		
R132SL	00D 960 9010 719	R,METAL FILM 47-J,1W	C060047065060S		
R132SR	00D 960 9010 719	R,METAL FILM 47-J,1W	C060047065060S		
R147-149	00D 963 9005 642	R,METAL FILM 1.2K-J,1W	C060012265050S		
VR101C	00D 960 0221 109	VR,SEMI CARBON EVN-DJAA03B	C541102115000S		
VR101FL	00D 960 0221 109	VR,SEMI CARBON EVN-DJAA03B	C541102115000S		
VR101FR	00D 960 0221 109	VR,SEMI CARBON EVN-DJAA03B	C541102115000S		

Ref. No.	Part No.	Part Name	Remarks	Q'ty	New
VR101SL VR101SR	00D 960 0221 109 00D 960 0221 109	VR,SEMI CARBON EVN-DJAA03B VR,SEMI CARBON EVN-DJAA03B	C541102115000S C541102115000S		
CAPACITORS GROUP					
C101 C101C C101FL C101FR	00D 963 9005 804 00D 963 0234 506 00D 963 0234 506 00D 963 0234 506	C,ELECT 100UF-M/25V C,ELECT 47UF-M/50V (Pb Free) C,ELECT 47UF-M/50V (Pb Free) C,ELECT 47UF-M/50V (Pb Free)	D040101084060S D040470087070S D040470087070S D040470087070S		
C101SL C101SR C102 C102C C102FL	00D 963 0234 506 00D 963 0234 506 00D 963 0224 503 00D 963 0234 205 00D 960 9010 133	C,ELECT 47UF-M/50V (Pb Free) C,ELECT 47UF-M/50V (Pb Free) C,ELECT 22UF-M/50V C,ELECT 10UF-M/50V C,ELECT 220UF-M/35V	D040470087070S D040470087070S D040220087060S D040100087070S D040221085060S		
C102FR C102SL C102SR C103 C103C	00D 960 9010 133 00D 963 0234 205 00D 963 0234 205 00D 963 9006 557 00D 963 9003 084	C,ELECT 220UF-M/35V C,ELECT 10UF-M/50V C,ELECT 10UF-M/50V C,ELECT 220UF-M/6.3V C,CERAMIC 100PF-K/500V	D040221085060S D040100087070S D040100087070S D040221081060S D00410106D050S		
C103FL C103FR C103SL C103SR C104	00D 963 9003 084 00D 963 9003 084 00D 963 9003 084 00D 963 9003 084 00D 963 9006 557	C,CERAMIC 100PF-K/500V C,CERAMIC 100PF-K/500V C,CERAMIC 100PF-K/500V C,CERAMIC 100PF-K/500V C,ELECT 220UF-M/6.3V	D00410106D050S D00410106D050S D00410106D050S D00410106D050S D040221081060S		
C104C C104FL C104FR C104SL C104SR	00D 963 9003 084 00D 963 9003 084 00D 963 9003 084 00D 963 9003 084 00D 963 9003 084	C,CERAMIC 100PF-K/500V C,CERAMIC 100PF-K/500V C,CERAMIC 100PF-K/500V C,CERAMIC 100PF-K/500V C,CERAMIC 100PF-K/500V	D00410106D050S D00410106D050S D00410106D050S D00410106D050S D00410106D050S		
C105 C105C C105FL C105FR C105SL	00D 963 9006 557 nsp nsp nsp nsp	C,ELECT 220UF-M/6.3V C,CERAMIC 0.022UF-Z/50V C,CERAMIC 0.022UF-Z/50V C,CERAMIC 0.022UF-Z/50V C,CERAMIC 0.022UF-Z/50V	D040221081060S D011223597160S D011223597160S D011223597160S D011223597160S		
C105SR C106 C107 C107C C107FL	nsp 00D 963 0293 709 nsp 00D 963 9003 097 00D 963 9003 097	C,CERAMIC 0.022UF-Z/50V C,ELECT 100UF-M/10V C,CERAMIC 0.01UF-K/50V C,FILM 0.1UF-K/250V C,FILM 0.1UF-K/250V	D011223597160S D040101082070S D011103777160S D02010407H080S D02010407H080S		
C107FR C107SL C107SR C108 C108C	00D 963 9003 097 00D 963 9003 097 00D 963 9003 097 00D 963 0149 400 00D 963 9006 544	C,FILM 0.1UF-K/250V C,FILM 0.1UF-K/250V C,FILM 0.1UF-K/250V CAP.E.GENERIC 10000UF/63V(M) C,ELECT 22UF-M/25V	D02010407H080S D02010407H080S D02010407H080S N211210388110S D040220084050S		
C108FL C108FR C108SL C108SR C109	00D 963 9006 544 00D 963 9006 544 00D 963 9006 544 00D 963 9006 544 00D 963 0149 400	C,ELECT 22UF-M/25V C,ELECT 22UF-M/25V C,ELECT 22UF-M/25V C,ELECT 22UF-M/25V CAP.E.GENERIC 10000UF/63V(M)	D040220084050S D040220084050S D040220084050S D040220084050S N211210388110S		
C109C C109FL C109FR C109SL C109SR	00D 963 0234 205 00D 963 0234 205 00D 963 0234 205 00D 963 0234 205 00D 963 0234 205	C,ELECT 10UF-M/50V C,ELECT 10UF-M/50V C,ELECT 10UF-M/50V C,ELECT 10UF-M/50V C,ELECT 10UF-M/50V	D040100087070S D040100087070S D040100087070S D040100087070S D040100087070S		
C110 C110C	00D 963 9003 097 00D 963 0338 208	C,FILM 0.1UF-K/250V C,CERAMIC 470PF-K/500V	D02010407H080S D00447127D050S		

Ref. No.	Part No.	Part Name	Remarks	Q'ty	New
C110FL	00D 963 0338 208	C,CERAMIC 470PF-K/500V	D00447127D050S		
C110FR	00D 963 0338 208	C,CERAMIC 470PF-K/500V	D00447127D050S		
C110SL	00D 963 0338 208	C,CERAMIC 470PF-K/500V	D00447127D050S		
C110SR	00D 963 0338 208	C,CERAMIC 470PF-K/500V	D00447127D050S		
C111	00D 963 9003 097	C,FILM 0.1UF-K/250V	D02010407H080S		
C111C	00D 963 0367 101	C,CERAMIC 220PF-J/500V	D00422106D05CS		
C111FL	00D 963 0367 101	C,CERAMIC 220PF-J/500V	D00422106D05CS		
C111FR	00D 963 0367 101	C,CERAMIC 220PF-J/500V	D00422106D05CS		
C111SL	00D 963 0367 101	C,CERAMIC 220PF-J/500V	D00422106D05CS		
C111SR	00D 963 0367 101	C,CERAMIC 220PF-J/500V	D00422106D05CS		
C112	00D 963 9003 097	C,FILM 0.1UF-K/250V	D02010407H080S		
C112C	00D 963 9003 194	C,FILM 0.0022UF-J/100V	D02022206C060S		
C112FL	00D 963 9003 194	C,FILM 0.0022UF-J/100V	D02022206C060S		
C112FR	00D 963 9003 194	C,FILM 0.0022UF-J/100V	D02022206C060S		
C112SL	00D 963 9003 194	C,FILM 0.0022UF-J/100V	D02022206C060S		
C112SR	00D 963 9003 194	C,FILM 0.0022UF-J/100V	D02022206C060S		
C113C	00D 963 0293 709	C,ELECT 100UF-M/10V	D040101082070S		
C113FL	00D 960 9010 133	C,ELECT 220UF-M/35V	D040221085060S		
C113FR	00D 960 9010 133	C,ELECT 220UF-M/35V	D040221085060S		
C113SL	00D 963 0293 709	C,ELECT 100UF-M/10V	D040101082070S		
C113SR	00D 963 0293 709	C,ELECT 100UF-M/10V	D040101082070S		
C114	00D 963 9003 097	C,FILM 0.1UF-K/250V	D02010407H080S		
C114C	00D 963 0216 100	C,CERAMIC 33PF-J/500V	D00033006D050S		
C114FL	00D 963 0216 100	C,CERAMIC 33PF-J/500V	D00033006D050S		
C114FR	00D 963 0216 100	C,CERAMIC 33PF-J/500V	D00033006D050S		
C114SL	00D 963 0216 100	C,CERAMIC 33PF-J/500V	D00033006D050S		
C114SR	00D 963 0216 100	C,CERAMIC 33PF-J/500V	D00033006D050S		
C115	00D 963 9003 097	C,FILM 0.1UF-K/250V	D02010407H080S		
C115SW	00D 963 9006 544	C,ELECT 22UF-M/25V	D040220084050S		
C117-120	nsp	C,CERAMIC 0.1UF-K/50V	D011104577160S		
C141SW1	00D 963 0234 205	C,ELECT 10UF-M/50V	D040100087070S		
C142SW1	nsp	C,CERAMIC 100PF-J/50V	D010101167160S		
C161	00D 963 0234 205	C,ELECT 10UF-M/50V	D040100087070S		
C162,163	nsp	C,CERAMIC 0.01UF-K/50V	D011103777160S		
C164-167	nsp	C,CERAMIC 100PF-J/50V	D010101167160S		
C168-172	00D 963 0244 606	C,ELECT 0.1UF-M/50V (Pb Free)	D040R10087080S		
C177	nsp	C,CERAMIC 0.01UF-K/50V	D011103777160S		
C178,179	00D 960 9010 010	C,ELECT 4.7UF-M/50V	D0404R7087250S		
C180,181	nsp	C,CERAMIC 0.01UF-K/50V	D011103777160S		
C182	00D 963 0324 005	C,ELECT 100UF-M/100V	D04010108C240S		
C183	00D 963 0293 602	C,ELECT 1UF-M/50V (Pb Free)	D040010087150S		
C190	00D 960 9010 010	C,ELECT 4.7UF-M/50V	D0404R7087250S		
OTHERS PARTS GROUP					
BKT101	nsp	SHIELD PLATE GND	3070045526010S		
CN101	nsp	CN,WIRE 110MM/10P	L000111100070S		
CN103	nsp	CN,WIRE 120MM/7P	L000121070060S		
CN201	nsp	CN,WIRE 70MM/6P	L000700060110S		
CN511	nsp	CN,WIRE 60MM/9P	L000600090020S		
CN704	nsp	CN,WIRE 15P	L000600150030S		
CP103	nsp	CN.WAFER 3P	L102526700300S		
CP104	nsp	CN.WAFER 3CKT	L108353280360S		
CP106	nsp	CN.WAFER 5P	L101100040510S		

Ref. No.	Part No.	Part Name	Remarks	Q'ty	New
CP107	nsp	CN.WAFER 3P	L102526700300S		
CP108	nsp	CN.WAFER 17P	L101100041710S		
CP541	nsp	CN.WAFER 3P	L101220030000S		
GND101	nsp	TERMINAL EARTH	3790040886000S		
JACK222	00D 963 0146 005	TER,RCA 1PIN	G600107A0000YS		
L101C	00D 963 0049 005	COIL INDUCTOR 0.5UH	D330R50000000S		
L101FL	00D 963 0049 005	COIL INDUCTOR 0.5UH	D330R50000000S		
L101FR	00D 963 0049 005	COIL INDUCTOR 0.5UH	D330R50000000S		
L101SL	00D 963 0049 005	COIL INDUCTOR 0.5UH	D330R50000000S		
L101SR	00D 963 0049 005	COIL INDUCTOR 0.5UH	D330R50000000S		
RLY541	00D 963 0218 506	RELAY BC3-24 24V 2A	G680240202040S		
TP101-105	nsp	CN.WAFER 3P	L101530140310S		
JP108	00D 963 0223 009	R,THICK 0-J,1/16W	C20000006M160S		
JP350-352	00D 963 0223 009	R,THICK 0-J,1/16W	C20000006M160S		

FRONT P.W.B. UNIT ASS'Y

	Ref. No.	Part No.	Part Name	Remarks	Q'ty	New
SEMICONDUCTORS GROUP						
	IC301	00D 963 0074 504	IC BU2090F-E2	J044209000010S		
	IC302	00D 262 3758 009	LC87F6D64A-QFP-E	J127876160010S		
▲	IC303	00D 960 0195 808	IC ICP-N15	J120001500030S		
	IC305	00D 963 0024 004	IC NJM2068M	J121206800020S		
	Q301-303	00D 963 0120 704	TR KRA102S	J520010200210S		
	Q304	00D 963 0121 606	TR KRC107S	J522107S00210S		
	Q305	00D 963 0102 803	TR 2SA933S	J5000933S0050S		
	Q306	00D 963 0120 801	TR KRC102S	J522010200210S		
	Q307-309	00D 963 0120 704	TR KRA102S	J520010200210S		
	Q310,311	00D 963 0120 801	TR KRC102S	J522010200210S		
	Q312	00D 960 0133 103	TR KSA916Y	J5000916Y0050S		
	Q542-546	00D 963 0121 208	TR KRC107M	J6020107M0010S		
	D301,302	00D 963 0020 309	D,SWITCHING 1SS133T	K000013300520S		
	D303	00D 963 0355 401	D,SWITCHING KDS4148U	K005041480030S		
	D304	00D 963 0020 309	D,SWITCHING 1SS133T	K000013300520S		
	D305-311	00D 963 0355 401	D,SWITCHING KDS4148U	K005041480030S		
	D312	00D 963 0328 409	D,SWITCHING 1N4007	K000400700010S		
	D313-316	00D 963 0355 401	D,SWITCHING KDS4148U	K005041480030S		
	D542	00D 963 0020 309	D,SWITCHING 1SS133T	K000013300520S		
	D543-545	00D 963 0355 401	D,SWITCHING KDS4148U	K005041480030S		
	D546	00D 963 0020 309	D,SWITCHING 1SS133T	K000013300520S		
	ZD302-308	00D 960 0095 500	D,ZENER MTZJ5.1B	K06005R144520S		
	ZD309	00D 960 0095 801	D,ZENER MTZJ6.8B	K06006R844520S		
	ZD310,311	00D 963 0046 202	D,ZENER MTZJ18B	K06018R044520S		
	ZD312,313	00D 960 0095 500	D,ZENER MTZJ5.1B	K06005R144520S		
	LED302-309	00D 960 0197 204	LED PI5-RD/HL50RDRF4T	K500052015010S		
	LED310	00D 963 0366 108	LED BL-BEG204-L 5PI	K500052004010S		
	FL301	00D 963 0257 305	DISPLAY,FLT HNA-16SM13T	K530161300020S		
RESISTORS GROUP						
	R372	00D 963 0215 907	R,METAL FILM 4.7-J,1W	C0604R7065050S		
	R378,379	00D 960 9009 270	R,METAL FILM 470-J,2W	C060047166520S		
	R501	00D 960 9003 700	R,METAL FILM 10-J,1/4W	C060010063050S		
	RP1-38	00D 963 0353 005	R,CHIP THICK 56K-J,1/16W	C20005636M160S		
	RG1-16	00D 963 0353 005	R,CHIP THICK 56K-J,1/16W	C20005636M160S		
CAPACITORS GROUP						
	C301,302	nsp	C,CERAMIC 100PF-J/50V	D010101167160S		
	C303	nsp	C,CERAMIC 0.022UF-K/25V	D011223777160S		
	C304	00D 963 9005 862	C,ELECT 47UF-M/16V	D040470083080S		
	C305	nsp	C,CERAMIC 100PF-J/50V	D010101167160S		
	C306	nsp	C,CERAMIC 0.047UF-Z/50V	D011473597160S		
	C307	00D 963 9005 862	C,ELECT 47UF-M/16V	D040470083080S		
	C308	nsp	C,CERAMIC 0.01UF-K/50V	D011103777160S		
	C309,310	00D 963 0293 602	C,ELECT 1UF-M/50V (Pb Free)	D040010087150S		

Ref. No.	Part No.	Part Name	Remarks	Q'ty	New
C311	00D 963 0233 303	C,CERAMIC 0.01UF-M/16V	D005103773530S		
C312	00D 963 9005 862	C,ELECT 47UF-M/16V	D040470083080S		
C315	nsp	C,CERAMIC 150PF-J/50V	D010151167160S		
C316,317	nsp	C,CERAMIC 330PF-J/50V	D010331167160S		
C318	nsp	C,CERAMIC 100PF-J/50V	D010101167160S		
C319,320	nsp	C,CERAMIC 0.01UF-K/50V	D011103777160S		
C321,322	00D 963 0233 303	C,CERAMIC 0.01UF-M/16V	D005103773530S		
C323-325	00D 963 0293 602	C,ELECT 1UF-M/50V (Pb Free)	D040010087150S		
C326	00D 963 9005 862	C,ELECT 47UF-M/16V	D040470083080S		
C327,328	nsp	C,CERAMIC 0.1UF-K/50V	D011104577160S		
C329	nsp	C,FILM 0.1UF-J/100V	D02010406C060S		
C330	00D 963 0021 900	C,FILM 0.047UF-J/100V	D02047306C060S		
C331	00D 963 0234 205	C,ELECT 10UF-M/50V	D040100087070S		
C332	nsp	C,CERAMIC 150PF-J/50V	D010151167160S		
C333	00D 963 0293 602	C,ELECT 1UF-M/50V (Pb Free)	D040010087150S		
C334	00D 963 0021 900	C,FILM 0.047UF-J/100V	D02047306C060S		
C335	nsp	C,CERAMIC 0.1UF-K/50V	D011104577160S		
C336	nsp	C,CERAMIC 100PF-J/50V	D010101167160S		
C337	00D 963 0293 602	C,ELECT 1UF-M/50V (Pb Free)	D040010087150S		
C338	nsp	C,CERAMIC 0.01UF-K/50V	D011103777160S		
C339	nsp	C,CERAMIC 100PF-J/50V	D010101167160S		
C340	nsp	C,CERAMIC 1000PF-K/50V	D011102777160S		
C341,342	nsp	C,CERAMIC 100PF-J/50V	D010101167160S		
C343	00D 963 0020 202	C,CERAMIC 0.1UF-Z/50V	D005104597530S		
C344,345	00D 963 0233 206	C,CERAMIC 0.001UF-K/50V	D005102177530S		
C346-349	nsp	C,CERAMIC 0.01UF-K/50V	D011103777160S		
C350	00D 963 0021 900	C,FILM 0.047UF-J/100V	D02047306C060S		
C351	00D 963 0293 602	C,ELECT 1UF-M/50V (Pb Free)	D040010087150S		
C352	00D 963 0234 205	C,ELECT 10UF-M/50V	D040100087070S		
C353,354	00D 963 0293 602	C,ELECT 1UF-M/50V (Pb Free)	D040010087150S		
C355	nsp	C,ELECT 470UF-M/63V	D040471088010S		
C356	00D 963 9003 097	C,FILM 0.1UF-K/250V	D02010407H080S		
C357,358	nsp	C,CERAMIC 0.047UF-Z/50V	D011473597160S		
C541	nsp	C,CERAMIC 2200PF-K/50V	D011222777160S		
C541FL	00D 963 0024 703	C,FILM 0.01UF-J/100V	D02010306C060S		
C542	nsp	C,CERAMIC 2200PF-K/50V	D011222777160S		
C542FR	00D 963 0024 703	C,FILM 0.01UF-J/100V	D02010306C060S		
C543	nsp	C,CERAMIC 2200PF-K/50V	D011222777160S		
C543FL	00D 963 0024 703	C,FILM 0.01UF-J/100V	D02010306C060S		
C544	nsp	C,CERAMIC 2200PF-K/50V	D011222777160S		
C544FR	00D 963 0024 703	C,FILM 0.01UF-J/100V	D02010306C060S		
C545	nsp	C,CERAMIC 2200PF-K/50V	D011222777160S		
C545C	00D 963 0024 703	C,FILM 0.01UF-J/100V	D02010306C060S		
C546	nsp	C,CERAMIC 2200PF-K/50V	D011222777160S		
C546SL	00D 963 0024 703	C,FILM 0.01UF-J/100V	D02010306C060S		
C547	nsp	C,CERAMIC 2200PF-K/50V	D011222777160S		
C547SR	00D 963 0024 703	C,FILM 0.01UF-J/100V	D02010306C060S		
C548	nsp	C,CERAMIC 2200PF-K/50V	D011222777160S		
C548SBL	00D 963 0024 703	C,FILM 0.01UF-J/100V	D02010306C060S		
C549	nsp	C,CERAMIC 2200PF-K/50V	D011222777160S		
C549SBR	00D 963 0024 703	C,FILM 0.01UF-J/100V	D02010306C060S		
OTHERS PARTS GROUP					
BD301-307	nsp	COIL,BEAD MB-160808	D340160800060S		

Ref. No.	Part No.	Part Name	Remarks	Q'ty	New
CN102	nsp	CN,WIRE 270,170MM/4P	L000271040040S		
CN301	nsp	CN,WIRE 2P	L000401020050S		
CN302A	nsp	CN,WIRE 5P	L000450050010S		
CN303A	nsp	CN,WIRE 8P	L000450080010S		
CN304	nsp	CN,WIRE 3P	L000500030050S		
CN305	nsp	CN,WIRE 10P	L000700100030S		
CN541		CN,WIRE 3P	L000251030080S		
CP101	nsp	CN.WAFER 10P	L102526701000S		
CP103	nsp	CN.WAFER 7P	L101220070000S		
CP105	nsp	CN.WAFER 4P ANGLE	L102526800400S		
CP301B	00D 963 0368 506	CN.FPC 35P	L131103500010S		
CP302	nsp	CN.WAFER 3P ANGLE	L102526803010S		
CP304	nsp	CN.WAFER 3P	L101220030000S		
CP305	nsp	CN.WAFER 10P	L101220100010S		
CP306	nsp	CN.WAFER 03P	L101220030010S		
G301	nsp	RING,TER WIRE 120MM/1P	8410121010060S		
G302	nsp	RING,TER WIRE 120MM/1P	8410121010110S		
G304	nsp	RING,TER WIRE 80MM/2P	8410800020040S		
JACK301	00D 963 0367 802	JACK,D3.5 EARPHONE JACK	G401PJ354H40YS		
JACK304	00D 963 0146 403	TER,RCA 3PIN	G606308HG110YS		
JACK501,502	00D 963 0146 607	TER,BOARD SCREW 8P	G614801A0200YS		
JACK503	00D 963 0158 608	TER,BOARD SCREW 2P	G611201A0200YS		
JK302	00D 963 0294 708	JACK,D6.5 PHONE	G402PJ612AG0YS		
L302	nsp	COIL INDUCTOR 10UH	D330100700520S		
L303	nsp	COIL INDUCTOR 100UH	D330101001020S		
RLY541	00D 963 0366 201	RELAY G5PA-28-MC 24V 5A	G680240502030S		
RLY543-546	00D 963 0366 201	RELAY G5PA-28-MC 24V 5A	G680240502030S		
RMC301	00D 963 0217 808	MODULE,REMOCON NJL34H380A	E940343800010S		
△ SW301	00D 963 0145 802	SW,PUSH SDDL-005-S(C-UL)	G000122006060S		
SW301A	00D 963 0095 305	SW,TACT SKHV10910D01	G180040500010S		
SW301C	00D 963 0095 305	SW,TACT SKHV10910D01	G180040500010S		
SW302A	00D 963 0095 305	SW,TACT SKHV10910D01	G180040500010S		
SW302B	00D 963 0095 305	SW,TACT SKHV10910D01	G180040500010S		
SW302C	00D 963 0095 305	SW,TACT SKHV10910D01	G180040500010S		
SW303A	00D 963 0095 305	SW,TACT SKHV10910D01	G180040500010S		
SW303B	00D 963 0095 305	SW,TACT SKHV10910D01	G180040500010S		
SW303C	00D 963 0095 305	SW,TACT SKHV10910D01	G180040500010S		
SW304A	00D 963 0095 305	SW,TACT SKHV10910D01	G180040500010S		
SW304B	00D 963 0095 305	SW,TACT SKHV10910D01	G180040500010S		
SW304C	00D 963 0095 305	SW,TACT SKHV10910D01	G180040500010S		
SW305A	00D 963 0095 305	SW,TACT SKHV10910D01	G180040500010S		
SW305B	00D 963 0095 305	SW,TACT SKHV10910D01	G180040500010S		
SW305C	00D 963 0095 305	SW,TACT SKHV10910D01	G180040500010S		
SW306A	00D 963 0095 305	SW,TACT SKHV10910D01	G180040500010S		
SW306B	00D 963 0095 305	SW,TACT SKHV10910D01	G180040500010S		
SW306C	00D 963 0095 305	SW,TACT SKHV10910D01	G180040500010S		
SW307A	00D 963 0095 305	SW,TACT SKHV10910D01	G180040500010S		
SW307B	00D 963 0095 305	SW,TACT SKHV10910D01	G180040500010S		

Ref. No.	Part No.	Part Name	Remarks	Q'ty	New
SW307C	00D 963 0095 305	SW,TACT SKHV10910D01	G180040500010S		
SW308A	00D 963 0095 305	SW,TACT SKHV10910D01	G180040500010S		
SW308B	00D 963 0095 305	SW,TACT SKHV10910D01	G180040500010S		
SW308C	00D 963 0095 305	SW,TACT SKHV10910D01	G180040500010S		
SW309A	00D 963 0095 305	SW,TACT SKHV10910D01	G180040500010S		
SW310	00D 963 0095 305	SW,TACT SKHV10910D01	G180040500010S		
VEC203	00D 963 0300 401	SW,ENCODER EC11B20C2	G121112020000S		
VEC301	00D 963 0095 208	SW,ENCODER EC16B24SO	G121162400070S		
VEC303	00D 963 0095 208	SW,ENCODER EC16B24SO	G121162400070S		
	nsp	HOLDER FLT	4320200026000S		

INPUT P.W.B. UNIT ASS'Y

Ref. No.	Part No.	Part Name	Remarks	Q'ty	New
SEMICONDUCTORS GROUP					
IC700	00D 963 0366 304	IC R2A15215FP		J084152150010S	
IC702	00D 963 0024 004	IC NJM2068M		J121206800020S	
IC705-718	00D 963 0024 004	IC NJM2068M		J121206800020S	
Q700,701	00D 960 0196 807	TR 2SK117Y		J5441170Y0050S	
Q702	00D 963 0120 704	TR KRA102S		J520010200210S	
Q703	00D 960 0285 006	TR KRC104S		J522104S00210S	
D700,701	00D 963 0355 401	D,SWITCHING KDS4148U		K005041480030S	
ZD700,701	00D 960 0222 603	D,ZENER MTZJ7.5A		K06007R544530S	
RESISTORS GROUP					
R706-709	00D 963 9005 639	R,METAL FILM 100-J,1W		C060010165060S	
R791VC	nsp	R,METAL FILM 120-J,1W		C060012165060S	
R791VE	nsp	R,METAL FILM 120-J,1W		C060012165060S	
CAPACITORS GROUP					
C700	00D 963 0234 205	C,ELECT 10UF-M/50V		D040100087070S	
C702SW	00D 960 9010 010	C,ELECT 4.7UF-M/50V		D0404R7087250S	
C703C	nsp	C,CERAMIC 0.047UF-Z/50V		D011473597160S	
C703SW	nsp	C,CERAMIC 0.047UF-Z/50V		D011473597160S	
C704,705	00D 963 9005 875	C,ELECT 47UF-M/25V		D040470084070S	
C706FL	00D 963 9005 875	C,ELECT 47UF-M/25V		D040470084070S	
C706FR	00D 963 9005 875	C,ELECT 47UF-M/25V		D040470084070S	
C707FL	00D 963 0234 205	C,ELECT 10UF-M/50V		D040100087070S	
C707FR	00D 963 0234 205	C,ELECT 10UF-M/50V		D040100087070S	
C707SW	00D 963 0234 205	C,ELECT 10UF-M/50V		D040100087070S	
C708FL	nsp	C,CERAMIC 33PF-J/50V		D010330167160S	
C708FR	nsp	C,CERAMIC 33PF-J/50V		D010330167160S	
C708SW	nsp	C,CERAMIC 47PF-J/50V		D010470167160S	
C709FL	nsp	C,CERAMIC 0.047UF-Z/50V		D011473597160S	
C709FR	nsp	C,CERAMIC 0.047UF-Z/50V		D011473597160S	
C709SW	nsp	C,CERAMIC 0.047UF-Z/50V		D011473597160S	
C710	00D 963 0223 009	R,CHIP THICK 0-J,1/16W		C20000006M160S	
C710FL	nsp	C,CERAMIC 100PF-J/50V		D010101167160S	
C710FR	nsp	C,CERAMIC 100PF-J/50V		D010101167160S	
C710SW	nsp	C,CERAMIC 100PF-J/50V		D010101167160S	
C711	00D 963 0223 009	R,CHIP THICK 0-J,1/16W		C20000006M160S	
C711FL	nsp	C,CERAMIC 0.047UF-Z/50V		D011473597160S	
C711FR	nsp	C,CERAMIC 0.047UF-Z/50V		D011473597160S	
C711SW	nsp	C,CERAMIC 0.047UF-Z/50V		D011473597160S	
C712	00D 963 0293 602	C,ELECT 1UF-M/50V (Pb Free)		D040010087150S	
C713-715	00D 963 0223 009	R,CHIP THICK 0-J,1/16W		C20000006M160S	
C716-727	00D 960 9009 814	C,CERAMIC 330PF-J/50V		D010331167160S	
C728-731	nsp	C,CERAMIC 20PF-J/50V		D010200167160S	
C732-739	00D 960 9009 814	C,CERAMIC 330PF-J/50V		D010331167160S	
C740-751	00D 963 0234 205	C,ELECT 10UF-M/50V		D040100087070S	
C751A	00D 963 0234 205	C,ELECT 10UF-M/50V		D040100087070S	
C751B	00D 963 0234 205	C,ELECT 10UF-M/50V		D040100087070S	
C751C	00D 963 0234 205	C,ELECT 10UF-M/50V		D040100087070S	
C751D	00D 963 0234 205	C,ELECT 10UF-M/50V		D040100087070S	

Ref. No.	Part No.	Part Name	Remarks	Q'ty	New
C751E	00D 963 0234 205	C,ELECT 10UF-M/50V	D040100087070S		
C751F	00D 963 0234 205	C,ELECT 10UF-M/50V	D040100087070S		
C751G	00D 963 0234 205	C,ELECT 10UF-M/50V	D040100087070S		
C751H	00D 963 0234 205	C,ELECT 10UF-M/50V	D040100087070S		
C751J	00D 963 0234 205	C,ELECT 10UF-M/50V	D040100087070S		
C751K	00D 963 0234 205	C,ELECT 10UF-M/50V	D040100087070S		
C751L	00D 963 0234 205	C,ELECT 10UF-M/50V	D040100087070S		
C751M	00D 963 0234 205	C,ELECT 10UF-M/50V	D040100087070S		
C751N	00D 963 0234 205	C,ELECT 10UF-M/50V	D040100087070S		
C751P	00D 963 0234 205	C,ELECT 10UF-M/50V	D040100087070S		
C751Q	00D 963 0234 205	C,ELECT 10UF-M/50V	D040100087070S		
C751R	00D 963 0234 205	C,ELECT 10UF-M/50V	D040100087070S		
C751S	00D 963 0234 205	C,ELECT 10UF-M/50V	D040100087070S		
C751T	00D 963 0234 205	C,ELECT 10UF-M/50V	D040100087070S		
C751U	00D 963 0234 205	C,ELECT 10UF-M/50V	D040100087070S		
C751V	00D 963 0234 205	C,ELECT 10UF-M/50V	D040100087070S		
C752	00D 963 0234 205	C,ELECT 10UF-M/50V	D040100087070S		
C752A	nsp	C,CERAMIC 0.047UF-Z/50V	D011473597160S		
C752B	nsp	C,CERAMIC 0.047UF-Z/50V	D011473597160S		
C752C	nsp	C,CERAMIC 0.047UF-Z/50V	D011473597160S		
C752D	nsp	C,CERAMIC 0.047UF-Z/50V	D011473597160S		
C752E	nsp	C,CERAMIC 0.047UF-Z/50V	D011473597160S		
C752F	nsp	C,CERAMIC 0.047UF-Z/50V	D011473597160S		
C752G	nsp	C,CERAMIC 0.047UF-Z/50V	D011473597160S		
C752H	nsp	C,CERAMIC 0.047UF-Z/50V	D011473597160S		
C752J	nsp	C,CERAMIC 0.047UF-Z/50V	D011473597160S		
C752K	nsp	C,CERAMIC 0.047UF-Z/50V	D011473597160S		
C752L	nsp	C,CERAMIC 0.047UF-Z/50V	D011473597160S		
C752M	nsp	C,CERAMIC 0.047UF-Z/50V	D011473597160S		
C752N	nsp	C,CERAMIC 0.047UF-Z/50V	D011473597160S		
C752P	nsp	C,CERAMIC 0.047UF-Z/50V	D011473597160S		
C752Q	nsp	C,CERAMIC 0.047UF-Z/50V	D011473597160S		
C752R	nsp	C,CERAMIC 0.047UF-Z/50V	D011473597160S		
C752S	nsp	C,CERAMIC 0.047UF-Z/50V	D011473597160S		
C752T	nsp	C,CERAMIC 0.047UF-Z/50V	D011473597160S		
C752U	nsp	C,CERAMIC 0.047UF-Z/50V	D011473597160S		
C752V	nsp	C,CERAMIC 0.047UF-Z/50V	D011473597160S		
C752W	nsp	C,CERAMIC 0.1UF-Z/50V	D011104597160S		
C752X	nsp	C,CERAMIC 0.1UF-Z/50V	D011104597160S		
C753-771	00D 963 0234 205	C,ELECT 10UF-M/50V	D040100087070S		
C772,773	00D 963 0293 806	C,ELECT 100UF-M/10V (Pb Free)	D040101082090S		
C774	nsp	C,FILM 0.15UF-K/63V	D020154078060S		
C775	00D 963 0021 900	C,FILM 0.047UF-J/100V	D02047306C060S		
C776	00D 960 9008 640	C,FILM 0.022UF-J/100V	D02022306C060S		
C777	00D 963 0234 205	C,ELECT 10UF-M/50V	D040100087070S		
C778,779	nsp	C,CERAMIC 100PF-J/50V	D010101167160S		
C780	00D 963 0234 205	C,ELECT 10UF-M/50V	D040100087070S		
C781	00D 960 9008 640	C,FILM 0.022UF-J/100V	D02022306C060S		
C782	00D 963 0021 900	C,FILM 0.047UF-J/100V	D02047306C060S		
C783	nsp	C,FILM 0.15UF-K/63V	D020154078060S		
C784-790	00D 963 0293 806	C,ELECT 100UF-M/10V (Pb Free)	D040101082090S		
C791,792	00D 963 0234 205	C,ELECT 10UF-M/50V	D040100087070S		
C794	00D 963 0293 806	C,ELECT 100UF-M/10V (Pb Free)	D040101082090S		
C795-799	00D 963 0234 205	C,ELECT 10UF-M/50V	D040100087070S		
C800,801	00D 960 9010 832	C,ELECT 10UF-M/16V	D040100083050S		

Ref. No.	Part No.	Part Name	Remarks	Q'ty	New
OTHERS PARTS GROUP					
CLAMP501	nsp	CLAMP WIRE(SOLDER)		4330000120000S	
CN306	nsp	CN,WIRE 480MM/3P		L000481030060S	
CN514	nsp	CN,WIRE 13P		L000181130010S	
CN702	nsp	CN.HOUSING 15P		L120912150010S	
CN703	nsp	CN.WAFER 8P		L101100030810S	
CN704	nsp	CN.WAFER 19P		L101100031910S	
CN706	nsp	CN,WIRE 5P		L000121050080S	
CP704	nsp	CN.WAFER 15P		L101220150000S	
CP705	nsp	CN.WAFER 3P		L101220030000S	
JACK701	00D 963 0132 103	TER,RCA 4PIN		G602405B0400YS	
JACK702	00D 963 0388 203	TER,RCA 4PIN		G602405B5500YS	
JACK703	00D 963 0132 103	TER,RCA 4PIN		G602405B0400YS	
JACK704,705	00D 963 0132 307	TER,RCA 6PIN		G603603B05000S	

POWER P.W.B. UNIT ASS'Y

	Ref. No.	Part No.	Part Name	Remarks	Q'ty	New
SEMICONDUCTORS GROUP						
△	IC501	00D 963 0057 806	IC KIA78R05PI	J126780500370S		
	IC502	00D 960 0195 808	IC ICP-N15	J120001500030S		
	IC515	00D 960 0174 900	IC KIA7815API	J126781500000S		
	IC516	00D 963 0021 502	IC KIA7915PI	J126791500030S		
	IC517	00D 960 0100 301	IC KIA7812API	J126781200040S		
	Q501	00D 960 0196 409	TR 2SC1740SR	J5021740S0010S		
	Q502	00D 963 0121 208	TR KRC107M	J6020107M0010S		
	Q503	00D 960 0196 409	TR 2SC1740SR	J5021740S0010S		
	D501-503	00D 276 0401 905	D,SWITCHING 1SS133T	K000013300520S		
	D504-507	00D 963 0328 409	D,SWITCHING 1N4007	K000400700010S		
	D508,509	00D 276 0401 905	D,SWITCHING 1SS133T	K000013300520S		
	D521,522	00D 276 0401 905	D,SWITCHING 1SS133T	K000013300520S		
	D523-526	00D 963 0328 409	D,SWITCHING 1N4007	K000400700010S		
	ZD501	00D 960 0095 500	D,ZENER MTZJ5.1B	K06005R144520S		
	ZD502	00D 963 0219 903	D,ZENER MTZJ16B	K06016R044520S		
RESISTORS GROUP						
	R507	00D 241 2376 964	R,METAL FILM 47-J,1/4W	C060047063050S		
	R516-519	00D 963 0216 003	R,METAL FILM 0.22-J,1W	C060R22065050S		
	R520	00D 963 0215 907	R,METAL FILM 4.7-J,1W	C0604R7065050S		
CAPACITORS GROUP						
	C501	00D 963 0234 205	C,ELECT 10UF-M/50V	D040100087070S		
	C502	00D 963 0217 002	C,ELECT 3300UF-M/16V	D040332083010S		
	C503	00D 963 0293 602	C,ELECT 1UF-M/50V (Pb Free)	D040010087150S		
	C504	00D 963 0323 802	C,CERAMIC AC(SAFETY) 0.0047UF 250VAC	D00847208H010S		
	C506	00D 963 0293 602	C,ELECT 1UF-M/50V (Pb Free)	D040010087150S		
	C526,527	00D 960 0186 202	C,ELECT 220UF-M/35V	D040221085050S		
	C528	00D 963 0324 908	C,ELECT 4700UF-M/35V	D040472085020S		
	C529	00D 963 0224 707	C,ELECT 2200UF-M/35V	D040222085020S		
	C530-532	00D 963 0021 900	C,FILM 0.047UF-J/100V	D02047306C060S		
	C534,535	00D 963 0234 205	C,ELECT 10UF-M/50V	D040100087070S		
OTHERS PARTS GROUP						
	BKT501,502	nsp	SHIELD PLATE GND	3070045526010S		
	CLAMP102-105	nsp	CLAMP WIRE(SOLDER)	4330000120000S		
	CN505	nsp	CN.WAFER 7P	L101100030710S		
	CN506	nsp	CN.WAFER 12P	L101100031210S		
	CN511	nsp	CN,WIRE 9P	L000600090020S		
	CP501	nsp	CN.WAFER 2CKT,YEL	L108353280290S		
	CP503	nsp	CN.WAFER 2CKT,RED	L108353280280S		
	CP504	nsp	CN.WAFER ST2P	L108202000220S		
	CP505	nsp	CN.WAFER 7P	L101100040710S		
	CP506	nsp	CN.WAFER 12P	L101100041210S		
	CP511	nsp	CN.WAFER 9P	L101220090000S		

	Ref. No.	Part No.	Part Name	Remarks	Q'ty	New
	CP513	nsp	CN.WAFER 3P ANGLE	L102526803010S		
	CP514	nsp	CN.WAFER 13P	L101220130000S		
⚠	F501	00D 963 0104 801	FUSE T3.15A /250V	N751223151110S		
	F501A	nsp	HOLDER,FUSE CLIP	G645000050010S		
	F501B	nsp	HOLDER,FUSE CLIP	G645000050010S		
⚠	F503	00D 963 0104 704	FUSE T2.5A /250V	N751222501110S		
	F503A	nsp	HOLDER,FUSE CLIP	G645000050010S		
	F503B	nsp	HOLDER,FUSE CLIP	G645000050010S		
	GND501	nsp	TERMINAL EARTH	3790040886000S		
	RLY501	00D 963 0218 205	RELAY HL3-1A-9SH DC9V 1A	G680090102020S		
⚠	SUB501	00D 963 0382 801	SUB TRANS	8200280150410S		
		nsp	HEAT SINK	2120043538050S		
		nsp	HEAT SINK HEAT SINK REG TR(24X45)	2120044298010S		
		nsp	SCREW,TAP TITE +2S 3*8 B-TYPE ZNW/BH	B020030081B10S		
		00D 963 0328 409	D,SWITCHING 1N4007	K000400700010S		
		nsp	FUSE LABEL T4AL 250V	5507000001090S		
⚠		00D 960 0143 203	SOCKET,POWER RECEPTA	G435040110000S		

2CH-AMP P.W.B. UNIT ASS'Y

Ref. No.	Part No.	Part Name	Remarks	Q'ty	New
SEMICONDUCTORS GROUP					
IC401D	00D 960 0159 501	IC KIA7805API	J126780500110S		
IC401H	00D 963 0388 805	CN,WIRE 110MM/3P	L000111030040S		
IC402D	00D 963 0226 608	IC KIA78R33PI	J12678R330010S		
IC402X	00D 963 0366 603	IC KIA1117PI50	J126111750050S		
IC403D	00D 963 0366 706	IC KIA1117PI00	J126111700050S		
Q401SBL	00D 963 0044 204	TR 2SD2390-Y	J5032390Y0000S		
Q401SBR	00D 963 0044 204	TR 2SD2390-Y	J5032390Y0000S		
Q402D	00D 960 0097 304	TR KRC102MTR	J6020102M0010S		
Q402SBL	00D 963 0044 107	TR 2SB1560-Y	J5011560Y0000S		
Q402SBR	00D 963 0044 107	TR 2SB1560-Y	J5011560Y0000S		
Q403SBL	00D 963 0280 107	TR 2SC3964	J502396400000S		
Q403SBR	00D 963 0280 107	TR 2SC3964	J502396400000S		
Q404SBL	00D 960 0196 506	TR KSC1845F	J5021845F0000S		
Q404SBR	00D 960 0196 506	TR KSC1845F	J5021845F0000S		
Q405SBL	00D 273 0459 903	TR KTC2874B	J502287400010S		
Q405SBR	00D 273 0459 903	TR KTC2874B	J502287400010S		
Q406SBL	00D 960 0196 205	TR KSA992F	J5000992F0050S		
Q406SBR	00D 960 0196 205	TR KSA992F	J5000992F0050S		
Q407SBL	00D 960 0196 205	TR KSA992F	J5000992F0050S		
Q407SBR	00D 960 0196 205	TR KSA992F	J5000992F0050S		
Q408SBL	00D 960 0196 506	TR KSC1845F	J5021845F0000S		
Q408SBR	00D 960 0196 506	TR KSC1845F	J5021845F0000S		
Q409D	00D 960 0097 304	TR KRC102MTR	J6020102M0010S		
D401H	00D 963 0328 409	D,SWITCHING 1N4007	K000400700010S		
D401SBL	00D 963 0341 004	D,SWITCHING KDS4148U	K005041480030S		
D401SBR	00D 963 0341 004	D,SWITCHING KDS4148U	K005041480030S		
D401X	00D 963 0328 409	D,SWITCHING 1N4007	K000400700010S		
D402	00D 276 0401 905	D,SWITCHING 1SS133T	K000013300520S		
D402H	00D 963 0328 409	D,SWITCHING 1N4007	K000400700010S		
D402SBL	00D 963 0341 004	D,SWITCHING KDS4148U	K005041480030S		
D402SBR	00D 963 0341 004	D,SWITCHING KDS4148U	K005041480030S		
D402X	00D 963 0328 409	D,SWITCHING 1N4007	K000400700010S		
D403	00D 276 0401 905	D,SWITCHING 1SS133T	K000013300520S		
ZD401D	00D 960 0095 607	D,ZENER MTZJ5.6B	K06005R644520S		
ZD401SBL	00D 963 0367 008	D,ZENER 0.2W 3.3V UDZ S	K06603R34P400S		
ZD401SBR	00D 963 0367 008	D,ZENER 0.2W 3.3V UDZ S	K06603R34P400S		
ZD402SBL	00D 963 0367 008	D,ZENER 0.2W 3.0V UDZ S	K06603R04P400S		
ZD402SBR	00D 963 0367 008	D,ZENER 0.2W 3.0V UDZ S	K06603R04P400S		
RESISTORS GROUP					
R401D	00D 963 9006 269	R,FIXED 1WJ-0.22	N113135622820S		
R401H	00D 963 9006 269	R,FIXED 1WJ-0.22	N113135622820S		
R401X	00D 963 9006 269	R,FIXED 1WJ-0.22	N113135622820S		
R402D	00D 963 9006 269	R,FIXED 1WJ-0.22	N113135622820S		
R402H	00D 963 9006 269	R,FIXED 1WJ-0.22	N113135622820S		
R402X	00D 963 9006 269	R,FIXED 1WJ-0.22	N113135622820S		
R410SBL	00D 963 9005 642	R,METAL FILM 1.2K-J,1W	C060012265050S		
R410SBR	00D 963 9005 642	R,METAL FILM 1.2K-J,1W	C060012265050S		
R411SBL	00D 960 9010 719	R,METAL FILM 47-J,1W	C060047065060S		
R411SBR	00D 960 9010 719	R,METAL FILM 47-J,1W	C060047065060S		

Ref. No.	Part No.	Part Name	Remarks	Q'ty	New
R414SBL	00D 963 9006 285	R,FIXED 1WJ-5.6K	N113135656220S		
R414SBR	00D 963 9006 285	R,FIXED 1WJ-5.6K	N113135656220S		
R415SBL	00D 963 9006 285	R,FIXED 1WJ-5.6K	N113135656220S		
R415SBR	00D 963 9006 285	R,FIXED 1WJ-5.6K	N113135656220S		
R419SBL	00D 963 0215 907	R,METAL FILM 4.7-J,1W	C0604R7065050S		
R419SBR	00D 963 0215 907	R,METAL FILM 4.7-J,1W	C0604R7065050S		
R420SBL	00D 963 0215 907	R,METAL FILM 4.7-J,1W	C0604R7065050S		
R420SBR	00D 963 0215 907	R,METAL FILM 4.7-J,1W	C0604R7065050S		
R421SBL	00D 963 0345 903	R,FIXED 2WJ-0.47	N113136647820S		
R421SBR	00D 963 0345 903	R,FIXED 2WJ-0.47	N113136647820S		
R422SBL	00D 963 0345 903	R,FIXED 2WJ-0.47	N113136647820S		
R422SBR	00D 963 0345 903	R,FIXED 2WJ-0.47	N113136647820S		
R423SBL	00D 963 0345 903	R,FIXED 2WJ-0.47	N113136647820S		
R423SBR	00D 963 0345 903	R,FIXED 2WJ-0.47	N113136647820S		
R424SBL	00D 963 0345 903	R,FIXED 2WJ-0.47	N113136647820S		
R424SBR	00D 963 0345 903	R,FIXED 2WJ-0.47	N113136647820S		
R429SBL	00D 963 9006 256	R,FIXED 1WJ-10	N113135610020S		
R429SBR	00D 963 9006 256	R,FIXED 1WJ-10	N113135610020S		
R430SBL	00D 963 9006 256	R,FIXED 1WJ-10	N113135610020S		
R430SBR	00D 963 9006 256	R,FIXED 1WJ-10	N113135610020S		
VR401,402	00D 963 0366 407	VR,SEMI CARBON EVN-DCAA03B 1KB	C541102315000S		
CAPACITORS GROUP					
C401D	00D 963 0021 900	C,FILM 0.047UF-J/100V	D02047306C060S		
C401H	00D 963 0021 900	C,FILM 0.047UF-J/100V	D02047306C060S		
C401SBL	00D 963 9006 544	C,ELECT 22UF-M/25V	D040220084050S		
C401SBR	00D 963 9006 544	C,ELECT 22UF-M/25V	D040220084050S		
C401X	nsp	C,CERAMIC 0.1UF-K/50V	D011104577160S		
C402D	00D 963 0021 900	C,FILM 0.047UF-J/100V	D02047306C060S		
C402H	00D 963 0021 900	C,FILM 0.047UF-J/100V	D02047306C060S		
C402SBL	00D 963 0234 205	C,ELECT 10UF-M/50V	D040100087070S		
C402SBR	00D 963 0234 205	C,ELECT 10UF-M/50V	D040100087070S		
C402X	00D 963 9003 097	C,FILM 0.1UF-K/250V	D02010407H080S		
C403D	00D 963 0021 900	C,FILM 0.047UF-J/100V	D02047306C060S		
C403H	00D 963 0021 900	C,FILM 0.047UF-J/100V	D02047306C060S		
C403SBL	00D 963 0367 101	C,CERAMIC 220PF-J/500V	D00422106D05CS		
C403SBR	00D 963 0367 101	C,CERAMIC 220PF-J/500V	D00422106D05CS		
C404D	00D 960 0133 404	C,ELECT 1000UF 16V	D040103083020S		
C404H	00D 963 0217 002	C,ELECT 330UF-M/16V	D040332083010S		
C404SBL	00D 963 0338 208	C,CERAMIC 470PF-K/500V	D00447127D050S		
C404SBR	00D 963 0338 208	C,CERAMIC 470PF-K/500V	D00447127D050S		
C404X	00D 963 0276 409	C,ELECT 100UF-M/16V	D040101083090S		
C405D	00D 963 0338 402	C,ELECT 330UF-M/6.3V	D040331081050S		
C405SBL	00D 963 0216 100	C,CERAMIC 33PF-J/500V	D00033006D050S		
C405SBR	00D 963 0216 100	C,CERAMIC 33PF-J/500V	D00033006D050S		
C406D	nsp	C,CERAMIC 0.1UF-K/50V	D011104577160S		
C406SBL	00D 963 0293 709	C,ELECT 100UF-M/10V	D040101082070S		
C406SBR	00D 963 0293 709	C,ELECT 100UF-M/10V	D040101082070S		
C406X	nsp	C,CERAMIC 1000PF-K/50V	D011102777160S		
C407D	nsp	C,CERAMIC 1000PF-K/50V	D011102777160S		
C407SBL	00D 963 9003 194	C,FILM 0.0022UF-J/100V	D02022206C060S		
C407SBR	00D 963 9003 194	C,FILM 0.0022UF-J/100V	D02022206C060S		
C407X	00D 963 0293 709	C,ELECT 100UF-M/10V	D040101082070S		
C408D	00D 963 0338 402	C,ELECT 330UF-M/6.3V	D040331081050S		

Ref. No.	Part No.	Part Name	Remarks	Q'ty	New
C408SBL	00D 963 0234 506	C,ELECT 47UF-M/50V (Pb Free)	D040470087070S		
C408SBR	00D 963 0234 506	C,ELECT 47UF-M/50V (Pb Free)	D040470087070S		
C409D	nsp	C,CERAMIC 0.1UF-K/50V	D011104577160S		
C409SBL	00D 963 9003 084	C,CERAMIC 100PF-K/500V	D00410106D050S		
C409SBR	00D 963 9003 084	C,CERAMIC 100PF-K/500V	D00410106D050S		
C410D	00D 963 0338 402	C,ELECT 330UF-M/6.3V	D040331081050S		
C410SBL	00D 963 0234 205	C,ELECT 10UF-M/50V	D040100087070S		
C410SBR	00D 963 0234 205	C,ELECT 10UF-M/50V	D040100087070S		
C411D	nsp	C,CERAMIC 0.1UF-K/50V	D011104577160S		
C411SBL	00D 963 9003 084	C,CERAMIC 100PF-K/500V	D00410106D050S		
C411SBR	00D 963 9003 084	C,CERAMIC 100PF-K/500V	D00410106D050S		
C412D	nsp	C,CERAMIC 0.1UF-K/50V	D011104577160S		
C412SBL	nsp	C,CERAMIC 0.022UF-K/25V	D011223777160S		
C412SBR	nsp	C,CERAMIC 0.022UF-K/25V	D011223777160S		
C413D	00D 963 0024 907	C,ELECT 1000UF-M/6.3V	D040102081060S		
C413SBL	00D 963 9003 097	C,FILM 0.1UF-K/250V	D02010407H080S		
C413SBR	00D 963 9003 097	C,FILM 0.1UF-K/250V	D02010407H080S		
C443	nsp	C,CERAMIC 1000PF-K/50V	D011102777160S		
OTHERS PARTS GROUP					
CLAMP401	nsp	CLAMP WIRE(SOLDER)	4330000120000S		
CN203	nsp	CN,WIRE 160MM/3P	L000161030060S		
CN401A	nsp	CN,WIRE 5P	L000191050030S		
CN405	nsp	CN,WIRE 5P	L000321050020S		
CN705	nsp	CN,WIRE 150MM/3P	L000151030010S		
CN904	nsp	CN,WIRE 6P	L000141060030S		
CP102	nsp	CN.WAFER 3P	L102526700300S		
CP201	nsp	CN.WAFER 10P	L101220100000S		
CP402	nsp	CN.WAFER 3P	L102526700300S		
L401SBL	nsp	COIL INDUCTOR 0.5UH	D330R50000000S		
L401SBR	nsp	COIL INDUCTOR 0.5UH	D330R50000000S		
TP401,402	nsp	CN.WAFER 3P ANGLE	L101530150310S		
	00D 963 0328 409	D,SWITCHING 1N4007	K000400700010S		

CPU P.W.B. UNIT ASS'Y

Ref. No.	Part No.	Part Name	Remarks	Q'ty	New
SEMICONDUCTORS GROUP					
IC712-715	00D 963 0024 004	IC NJM2068M		J121206800020S	
IC804	963243000020D	IC,CPU MICRO PROCESS	M30626FHPFP	8952150800015	
IC805	00D 963 0326 906	IC LC72722PM-TLM-E		J124727220010S	
IC806	00D 960 0100 301	IC KIA7812API		J126781200040S	
IC813	00D 963 0367 204	IC SN74HC151PWR		J040741510070S	
IC817	00D 963 0244 907	IC SN74LV14APWR		J040741400180S	
IC818	00D 963 0367 307	IC SN74AHCU04PWR		J040740400290S	
IC824	00D 963 0043 807	IC BA4510F-E2/SOP8		J121451000010S	
IC827	00D 963 0043 807	IC BA4510F-E2/SOP8		J121451000010S	
IC830	00D 262 2813 903	SN74AHCT08PW-EL2 +C		J040740800190S	
Q704C	00D 963 0044 301	TR KTC2875B(MB)	<div style="border: 1px solid black; border-radius: 15px; padding: 5px; width: fit-content;"> ファームウェアをアップデートするときは、SDIで最終バージョンを確認して下さい。サービス基板はアップデートして使用下さい。 When update Firmware, please confirm a last version in SDI. Use the service board after updating it. </div>	J5222875B0010S	
Q704FL	00D 963 0044 301	TR KTC2875B(MB)		J5222875B0010S	
Q704FR	00D 963 0044 301	TR KTC2875B(MB)		J5222875B0010S	
Q704SBL	00D 963 0044 301	TR KTC2875B(MB)		J5222875B0010S	
Q704SBR	00D 963 0044 301	TR KTC2875B(MB)		J5222875B0010S	
Q704SL	00D 963 0044 301	TR KTC2875B(MB)		J5222875B0010S	
Q704SR	00D 963 0044 301	TR KTC2875B(MB)		J5222875B0010S	
Q704SW	00D 963 0044 301	TR KTC2875B(MB)		J5222875B0010S	
Q801	00D 963 0120 704	TR KRA102S		J520010200210S	
Q802-805	00D 963 0044 301	TR KTC2875B(MB)		J5222875B0010S	
Q806	00D 963 0121 509	TR KTC3875S		J522038750210S	
Q807	00D 960 0285 006	TR KRC104S		J522104S00210S	
Q808	00D 963 0148 508	TR KTA1504S		J520015040150S	
Q809	00D 963 0120 801	TR KRC102S (NB)		J522010200210S	
Q810D	00D 963 0245 100	D,SWITCHING KDS226ST1(C3)		K005022600020S	
Q811D	00D 963 0245 100	D,SWITCHING KDS226ST1(C3)		K005022600020S	
Q812D	00D 963 0120 801	TR KRC102S		J522010200210S	
Q813D	00D 963 0120 704	TR KRA102S		J520010200210S	
D801-804	00D 963 0355 401	D,SWITCHING KDS4148U		K005041480030S	
D805	00D 963 0328 409	D,SWITCHING 1N4007		K000400700010S	
D806,807	00D 963 0355 401	D,SWITCHING KDS4148U		K005041480030S	
D807D	00D 963 0355 401	D,SWITCHING KDS4148U		K005041480030S	
D808D	00D 963 0341 305	D,ESD IMSA-6802-01A		K067680200010S	
D809D	00D 963 0355 401	D,SWITCHING KDS4148U		K005041480030S	
D810D	00D 963 0341 305	D,ESD IMSA-6802-01A		K067680200010S	
D811D	00D 963 0341 305	D,ESD IMSA-6802-01A		K067680200010S	
ZD801	00D 963 0047 502	D,ZENER MTZJ3.3B		K06003R344520S	
RESISTORS GROUP					
R857	00D 960 9003 807	R,METAL FILM 100-J,1/4W		C060010163050S	
CAPACITORS GROUP					
C751C	00D 963 0234 205	C,ELECT 10UF-M/50V		D040100087070S	
C751FL	00D 963 0234 205	C,ELECT 10UF-M/50V		D040100087070S	
C751FR	00D 963 0234 205	C,ELECT 10UF-M/50V		D040100087070S	
C751SBL	00D 963 0234 205	C,ELECT 10UF-M/50V		D040100087070S	
C751SBR	00D 963 0234 205	C,ELECT 10UF-M/50V		D040100087070S	
C751SL	00D 963 0234 205	C,ELECT 10UF-M/50V		D040100087070S	
C751SR	00D 963 0234 205	C,ELECT 10UF-M/50V		D040100087070S	

Ref. No.	Part No.	Part Name	Remarks	Q'ty	New
C751SW	00D 963 0234 205	C,ELECT 10UF-M/50V	D040100087070S		
C752C	00D 963 0350 503	C,CERAMIC 390PF-J/50V	D010391167160S		
C752FL	00D 963 0223 708	C,CERAMIC 270PF-J/50V	D010271167160S		
C752FR	00D 963 0223 708	C,CERAMIC 270PF-J/50V	D010271167160S		
C752SBL	00D 960 9009 814	C,CERAMIC 330PF-J/50V	D010331167160S		
C752SBR	00D 960 9009 814	C,CERAMIC 330PF-J/50V	D010331167160S		
C752SL	00D 960 9009 814	C,CERAMIC 330PF-J/50V	D010331167160S		
C752SR	00D 960 9009 814	C,CERAMIC 330PF-J/50V	D010331167160S		
C752SW	00D 963 0350 503	C,CERAMIC 390PF-J/50V	D010391167160S		
C753C	00D 963 0224 008	C,CERAMIC 470PF-J/50V	D010471167160S		
C753FL	00D 963 0223 902	C,CERAMIC 39PF-J/50V	D010390167160S		
C753FR	00D 963 0223 902	C,CERAMIC 39PF-J/50V	D010390167160S		
C753SBL	00D 963 0223 708	C,CERAMIC 270PF-J/50V	D010271167160S		
C753SBR	00D 963 0223 708	C,CERAMIC 270PF-J/50V	D010271167160S		
C753SL	00D 963 0223 708	C,CERAMIC 270PF-J/50V	D010271167160S		
C753SR	00D 963 0223 708	C,CERAMIC 270PF-J/50V	D010271167160S		
C753SW	00D 963 0224 008	C,CERAMIC 470PF-J/50V	D010471167160S		
C755C	nsp	C,CERAMIC 0.1UF-Z/50V	D011104597160S		
C755FL	nsp	C,CERAMIC 0.1UF-Z/50V	D011104597160S		
C755FR	nsp	C,CERAMIC 0.1UF-Z/50V	D011104597160S		
C755SBL	nsp	C,CERAMIC 0.1UF-Z/50V	D011104597160S		
C755SBR	nsp	C,CERAMIC 0.1UF-Z/50V	D011104597160S		
C755SL	nsp	C,CERAMIC 0.1UF-Z/50V	D011104597160S		
C755SR	nsp	C,CERAMIC 0.1UF-Z/50V	D011104597160S		
C755SW	nsp	C,CERAMIC 0.1UF-Z/50V	D011104597160S		
C756C	00D 963 9003 194	C,FILM 0.0022UF-J/100V	D02022206C060S		
C756FL	00D 963 9003 194	C,FILM 0.0022UF-J/100V	D02022206C060S		
C756FR	00D 963 9003 194	C,FILM 0.0022UF-J/100V	D02022206C060S		
C756SBL	00D 963 9003 194	C,FILM 0.0022UF-J/100V	D02022206C060S		
C756SBR	00D 963 9003 194	C,FILM 0.0022UF-J/100V	D02022206C060S		
C756SL	00D 963 9003 194	C,FILM 0.0022UF-J/100V	D02022206C060S		
C756SR	00D 963 9003 194	C,FILM 0.0022UF-J/100V	D02022206C060S		
C756SW	00D 963 9003 194	C,FILM 0.0022UF-J/100V	D02022206C060S		
C757C	nsp	C,CERAMIC 10UF-Z/10V	D011106592200S		
C757FL	nsp	C,CERAMIC 10UF-Z/10V	D011106592200S		
C757FR	nsp	C,CERAMIC 10UF-Z/10V	D011106592200S		
C757SBL	nsp	C,CERAMIC 10UF-Z/10V	D011106592200S		
C757SBR	nsp	C,CERAMIC 10UF-Z/10V	D011106592200S		
C757SL	nsp	C,CERAMIC 10UF-Z/10V	D011106592200S		
C757SR	nsp	C,CERAMIC 10UF-Z/10V	D011106592200S		
C757SW	nsp	C,CERAMIC 10UF-Z/10V	D011106592200S		
C803	nsp	C,CERAMIC 100PF-J/50V	D010101167160S		
C804,805	nsp	C,CERAMIC 0.1UF-Z/50V	D011104597160S		
C806	nsp	C,CERAMIC 0.01UF-K/50V	D011103777160S		
C807,808	nsp	C,CERAMIC 0.022UF-Z/50V	D011223597160S		
C809	00D 963 0293 709	C,ELECT 100UF-M/10V	D040101082070S		
C810	nsp	C,CERAMIC 0.1UF-Z/50V	D011104597160S		
C811,812	00D 963 9004 614	C,CERAMIC 27PF-J/50V	D010270167160S		
C813	nsp	C,CERAMIC 0.1UF-Z/50V	D011104597160S		
C814-816	nsp	C,CERAMIC 0.01UF-K/50V	D011103777160S		
C817	nsp	C,CERAMIC 560PF-J/50V	D010561167160S		
C818	00D 960 9010 010	C,ELECT 4.7UF-M/50V	D0404R7087250S		
C819	nsp	C,CERAMIC 0.01UF-K/50V	D011103777160S		
C820	00D 960 9009 814	C,CERAMIC 330PF-J/50V	D010331167160S		
C821	00D 963 0234 205	C,ELECT 10UF-M/50V	D040100087070S		
C822	00D 963 9005 862	C,ELECT 47UF-M/16V	D040470083080S		

Ref. No.	Part No.	Part Name	Remarks	Q'ty	New
C823	nsp	C,CERAMIC 0.01UF-K/50V	D011103777160S		
C824,825	00D 963 0234 205	C,ELECT 10UF-M/50V	D040100087070S		
C826-831	nsp	C,CERAMIC 100PF-J/50V	D010101167160S		
C836,837	nsp	C,CERAMIC 0.022UF-Z/50V	D011223597160S		
C865L	nsp	C,CERAMIC 120PF-J/50V	D010121167160S		
C865R	nsp	C,CERAMIC 120PF-J/50V	D010121167160S		
C871L	00D 963 0216 304	C,FILM 0.001UF-J/100V	D02010206C060S		
C871R	00D 963 0216 304	C,FILM 0.001UF-J/100V	D02010206C060S		
C916D	nsp	C,CERAMIC 0.1UF-Z/50V	D011104597160S		
C917D	nsp	C,CERAMIC 0.1UF-Z/50V	D011104597160S		
C918D	nsp	C,CERAMIC 0.1UF-Z/50V	D011104597160S		
C921D	nsp	C,CERAMIC 100PF-J/50V	D010101167160S		
C923D	nsp	C,CERAMIC 22PF-J/50V	D010220167160S		
C924D	nsp	C,CERAMIC 22PF-J/50V	D010220167160S		
C927D	00D 963 9005 862	C,ELECT 47UF-M/16V	D040470083080S		
C928D	00D 963 9005 862	C,ELECT 47UF-M/16V	D040470083080S		
C931D	nsp	C,CERAMIC 100PF-J/50V	D010101167160S		
C932D	nsp	C,CERAMIC 0.01UF-K/50V	D011103777160S		
C933D	nsp	C,CERAMIC 0.01UF-K/50V	D011103777160S		
C934D	nsp	C,CERAMIC 0.01UF-K/50V	D011103777160S		
C935D	00D 960 9010 010	C,ELECT 4.7UF-M/50V	D0404R7087250S		
C936D	00D 960 9010 010	C,ELECT 4.7UF-M/50V	D0404R7087250S		
C937D	nsp	C,CERAMIC 1000PF-K/50V	D011102777160S		
C938D	00D 960 9010 010	C,ELECT 4.7UF-M/50V	D0404R7087250S		
C939D	nsp	C,CERAMIC 0.01UF-K/50V	D011103777160S		
C940D	nsp	C,CERAMIC 0.01UF-K/50V	D011103777160S		
C941D	00D 963 0244 606	C,ELECT 0.1UF-M/50V (Pb Free)	D040R10087080S		
C950D	nsp	C,CERAMIC 0.1UF-Z/50V	D011104597160S		
C951D	nsp	C,CERAMIC 0.1UF-Z/50V	D011104597160S		
C952D	00D 963 0234 205	C,ELECT 10UF-M/50V	D040100087070S		
C953D	00D 963 0234 205	C,ELECT 10UF-M/50V	D040100087070S		
C954D	nsp	C,CERAMIC 0.1UF-Z/50V	D011104597160S		
C955D	nsp	C,CERAMIC 0.1UF-Z/50V	D011104597160S		
C956D	nsp	C,CERAMIC 22PF-J/50V	D010220167160S		
C957D	nsp	C,CERAMIC 0.1UF-Z/50V	D011104597160S		
C959D	nsp	C,CERAMIC 22PF-J/50V	D010220167160S		
BC801	00D 254 4666 005	CE04W0H105ZC(FG)	D041105090010S		
OTHERS PARTS GROUP					
BD802-806	nsp	COIL,BEAD MB-160808	D340160800060S		
BD809D	nsp	COIL,BEAD MB-160808	D340160800060S		
BD810-817	nsp	COIL,BEAD MB-160808	D340160800060S		
CN106	nsp	CN.WAFER 5P	L101100030510S		
CN108	00D 963 0085 302	CN.WAFER 17P	L101100031710S		
CP01	nsp	CN.WAFER 16P	L101100041610S		
CP301A	00D 963 0367 400	CN.FPC 35P	L131524923520S		
CP701	nsp	CN.WAFER 19P	L101100041910S		
CP702	nsp	CN.WAFER 15P	L100912150010S		
CP703	nsp	CN.WAFER 8P	L101100040810S		
CP801	00D 963 0149 303	CN.FPC 15P	L131111500010S		
CP802	nsp	CN.WAFER 16P	L100912160010S		
CP803	nsp	CN.WAFER 16P	L101100041610S		

Ref. No.	Part No.	Part Name	Remarks	Q'ty	New
CP804	nsp	CN.WAFER 15P	L100912150010S		
CP805	nsp	CN.WAFER 08P	L100912080010S		
CP1001	nsp	CN.WAFER 08P	L101100040810S		
CP1002	nsp	CN.WAFER 9P	L101100040910S		
JACK801	00D 963 0217 905	TER,RCA 2PIN	G601206A0200YS		
JACK802	00D 963 0294 601	JACK,D3.5 EARPHONE	G40100350000YS		
L801D	nsp	COIL INDUCTOR 4.7UH	D3304R7000150S		
L802D	nsp	COIL INDUCTOR 4.7UH	D3304R7000150S		
L803D	nsp	COIL INDUCTOR 4.7UH	D3304R7000150S		
L805D	nsp	COIL INDUCTOR 4.7UH	D3304R7000150S		
L806D	nsp	COIL INDUCTOR 22UH	D330220010050S		
L807D	nsp	COIL INDUCTOR 22UH	D330220010050S		
TP803	nsp	CN.WAFER 8P	L101220080000S		
TP804	nsp	CN.WAFER 4P	L101220040000S		
X801	00D 963 0217 701	RESONATOR,CERAMIC ZTT12.00MT	E830120000060S		
X802	00D 963 0217 604	CRYSTAL 4.332MHZ	E800433200100S		
OPT801D	00D 963 0237 503	MODULE JSR1165-C	E100116500040S		
OPT802D	00D 963 0237 503	MODULE JSR1165-C	E100116500040S		
	nsp	CN,WIRE 110MM/1P	L000111010010S		

HDMI P.W.B. UNIT ASS'Y

Ref. No.	Part No.	Part Name	Remarks	Q'ty	New
SEMICONDUCTORS GROUP					
IC01	nsp	SII9185CTU	00D2623721007		
IC03	nsp	IC SE1117-1.8	J126111718010S		
IC04	nsp	IC F2621E-01-PR	J080260200040S		
IC05	nsp	IC SE1117-33-PF	J126111733020S		
IC06	nsp	IC AK4385	J042438500010S		
IC07	nsp	IC SN74LVO8APW-EL2	J040740800200S		
IC08,09	nsp	IC SN74AHCT08-EL2	J040740800190S		
IC10	nsp	IC NJM2068M	J121206800020S		
IC11	nsp	IC KIA1117PI50	J126111750050S		
IC12	nsp	IC BU4094BCF-E2	J040140940030S		
IC801	nsp	ADSP21367KSZ1A1136	00D2623709016		
IC802	nsp	W9864G2GH-7	00D2623746008		
IC803	nsp	IC EN29LV160T-70TCP	J005291600010S		
IC807	nsp	LC89057W-VF4A	00D2623449004		
IC808	nsp	ADAU1328BSTZ1136	00D2623645015		
IC809-811	nsp	IC SN74LVC244APWR	J040742440230S		
IC812	nsp	IC SN74HCT244PWR	J040742440220S		
IC814,815	nsp	IC SN74HCT00PWR	J040740000210S		
IC816	nsp	74LVX157MTC +C	00D2622870904		
IC823	nsp	IC KIA7805API	J126780500110S		
IC825,826	nsp	IC SN74LVC74APWR	J040747400200S		
IC832	nsp	IC SE1117-33-PF	J126111733020S		
Q01,02	nsp	TR KRC102S	J522010200210S		
Q03,04	nsp	TR KRC104S	J522104S00210S		
Q05	nsp	TR KRA102S	J520010200210S		
Q06	nsp	TR KTC3875S	J522038750210S		
Q07	nsp	TR KRC104S	J522104S00210S		
Q08	nsp	TR KRC102S	J522010200210S		
Q09	nsp	TR KRA104S	J520010400210S		
Q10,11	nsp	TR KRC102S	J522010200210S		
Q12,13	nsp	TR KRA102S	J520010200210S		
Q14-17	nsp	TR KTC2875B(MB)	J5222875B0010S		
Q810D	nsp	TR KRC102S	J522010200210S		
Q811D	nsp	TR KRA102S	J520010200210S		
Q814D	nsp	TR KRA102S	J520010200210S		
D01-36	nsp	D,ESD IMSA-6802-01A	K067680200010S		
D37-44	nsp	D,SWITCHING KDS4148U	K005041480030S		
RESISTORS GROUP					
R41,42	nsp	COIL,BEAD MB-160808	D340160800060S		
R62	nsp	COIL,BEAD MB-160808	D340160800060S		
CAPACITORS GROUP					
C01	nsp	C,CERAMIC 1000PF-K/50V	D011102777160S		
C02-05	nsp	C,CERAMIC 0.1UF-K/50V	D011104577162S		
C06,07	nsp	C,CERAMIC 1000PF-K/50V	D011102777160S		
C08-14	nsp	C,CERAMIC 0.1UF-K/50V	D011104577162S		
C15-17	nsp	C,CERAMIC 1000PF-K/50V	D011102777160S		
C18,19	nsp	C,CERAMIC 0.1UF-K/50V	D011104577162S		
C20	nsp	C,CERAMIC 1000PF-K/50V	D011102777160S		

Ref. No.	Part No.	Part Name	Remarks	Q'ty	New
C21	nsp	C,CERAMIC 100PF-J/50V	D010101167160S		
C22	nsp	C,CERAMIC 1000PF-K/50V	D011102777160S		
C23	nsp	C,CERAMIC 100PF-J/50V	D010101167160S		
C24,25	nsp	C,ELECT 10UF-MVG/16V	D050100083460S		
C26,27	nsp	C,CERAMIC 0.01UF-K/50V	D011103777160S		
C28H	nsp	C,ELECT 10UF-MVG/16V	D050100083460S		
C29	nsp	C,CERAMIC 0.1UF-K/50V	D011104577162S		
C29H	nsp	C,ELECT 10UF-MVG/16V	D050100083460S		
C30	nsp	C,CERAMIC 0.1UF-K/50V	D011104577162S		
C30H	nsp	C,ELECT 10UF-MVG/16V	D050100083460S		
C31,32	nsp	C,CERAMIC 0.1UF-K/50V	D011104577162S		
C33-36	nsp	C,CERAMIC 20PF-J/50V	D010200167160S		
C37-39	nsp	C,CERAMIC 0.1UF-K/50V	D011104577162S		
C40	nsp	C,ELECT 22UF-MV/6.3V	D050220081450S		
C41	nsp	C,CERAMIC 0.1UF-K/50V	D011104577162S		
C42,43	nsp	C,CERAMIC 5PF-C/50V	D010050107160S		
C44	nsp	C,CERAMIC 0.1UF-K/50V	D011104577162S		
C45	nsp	C,CERAMIC 1000PF-K/50V	D011102777160S		
C46	nsp	C,CERAMIC 4.7UF-K/10V	D011475572200S		
C47-50	nsp	C,CERAMIC 0.1UF-K/50V	D011104577162S		
C51	nsp	C,CERAMIC 1000PF-K/50V	D011102777160S		
C52	nsp	C,CERAMIC 0.1UF-K/50V	D011104577162S		
C53	nsp	C,ELECT 10UF-MVG/16V	D050100083460S		
C54	nsp	C,CERAMIC 0.1UF-K/50V	D011104577162S		
C55	nsp	C,CERAMIC 4.7UF-K/10V	D011475572200S		
C56,57	nsp	C,CERAMIC 1000PF-K/50V	D011102777160S		
C58	nsp	C,CERAMIC 0.1UF-K/50V	D011104577162S		
C59	nsp	C,CERAMIC 1000PF-K/50V	D011102777160S		
C60	nsp	C,CERAMIC 0.1UF-K/50V	D011104577162S		
C61	nsp	C,CERAMIC 1000PF-K/50V	D011102777160S		
C62	nsp	C,CERAMIC 0.1UF-K/50V	D011104577162S		
C63-65	nsp	C,CERAMIC 100PF-J/50V	D010101167160S		
C66	nsp	C,CERAMIC 0.01UF-K/50V	D011103777160S		
C68	nsp	C,ELECT 0.1UF-MVG/50V	D050R10080010S		
C69,70	nsp	C,CERAMIC 0.1UF-K/50V	D011104577162S		
C71,72	nsp	C,ELECT 22UF-MV/6.3V	D050220081450S		
C73,74	nsp	C,ELECT 10UF-MVG/16V	D050100083460S		
C75	nsp	C,CERAMIC 560PF-J/50V	D010561167160S		
C76	nsp	C,CERAMIC 1800PF-K/50V	D011182777160S		
C77,78	nsp	C,CERAMIC 560PF-J/50V	D010561167160S		
C79	nsp	C,CERAMIC 1800PF-K/50V	D011182777160S		
C80	nsp	C,CERAMIC 560PF-J/50V	D010561167160S		
C82	nsp	C,CERAMIC 1000PF-K/50V	D011102777160S		
C831D	nsp	C,CERAMIC 0.1UF-K/50V	D011104577162S		
C832D	nsp	C,CERAMIC 1000PF-K/50V	D011102177101S		
C833D	nsp	C,CERAMIC 100PF-J/50V	D011101167101S		
C834D	nsp	C,CERAMIC 100PF-J/50V	D011101167101S		
C835D	nsp	C,CERAMIC 0.01UF-K/50V	D011103177101S		
C836D	nsp	C,CERAMIC 0.01UF-K/50V	D011103177101S		
C837D	nsp	C,CERAMIC 100PF-J/50V	D011101167101S		
C838D	nsp	C,CERAMIC 100PF-J/50V	D011101167101S		
C839D	nsp	C,CERAMIC 100PF-J/50V	D011101167101S		
C840D	nsp	C,CERAMIC 100PF-J/50V	D011101167101S		
C841D	nsp	C,CERAMIC 100PF-J/50V	D011101167101S		
C842D	nsp	C,CERAMIC 100PF-J/50V	D011101167101S		
C843D	nsp	C,CERAMIC 100PF-J/50V	D011101167101S		

Ref. No.	Part No.	Part Name	Remarks	Q'ty	New
C844D	nsp	C,CERAMIC 100PF-J/50V	D011101167101S		
C845D	nsp	C,CERAMIC 0.1UF-K/50V	D011104177101S		
C846D	nsp	C,CERAMIC 1000PF-K/50V	D011102177101S		
C847D	nsp	C,CERAMIC 1000PF-K/50V	D011102177101S		
C848D	nsp	C,CERAMIC 1000PF-K/50V	D011102177101S		
C849D	nsp	C,CERAMIC 1000PF-K/50V	D011102177101S		
C850D	nsp	C,CERAMIC 1000PF-K/50V	D011102177101S		
C851D	nsp	C,CERAMIC 1000PF-K/50V	D011102177101S		
C852D	nsp	C,CERAMIC 1000PF-K/50V	D011102177101S		
C853D	nsp	C,CERAMIC 1000PF-K/50V	D011102177101S		
C854D	nsp	C,CERAMIC 0.1UF-K/50V	D011104177101S		
C855D	nsp	C,CERAMIC 0.1UF-K/50V	D011104177101S		
C856D	nsp	C,CERAMIC 0.1UF-K/50V	D011104177101S		
C857D	nsp	C,CERAMIC 0.1UF-K/50V	D011104177101S		
C858D	nsp	C,CERAMIC 0.1UF-K/50V	D011104177101S		
C859D	nsp	C,CERAMIC 0.1UF-K/50V	D011104177101S		
C860D	nsp	C,CERAMIC 0.1UF-K/50V	D011104177101S		
C861D	nsp	C,CERAMIC 0.1UF-K/50V	D011104177101S		
C862D	nsp	C,CERAMIC 0.01UF-K/50V	D011103177101S		
C863D	nsp	C,CERAMIC 100PF-J/50V	D011101167101S		
C864D	nsp	C,CERAMIC 4.7UF-K/10V	D011475572200S		
C865D	nsp	C,CERAMIC 5PF-C/50V	D010050107160S		
C866D	nsp	C,CERAMIC 5PF-C/50V	D010050107160S		
C871D	nsp	C,CERAMIC 0.01UF-K/50V	D011103177101S		
C873D	nsp	C,CERAMIC 0.01UF-K/50V	D011103177101S		
C875D	nsp	C,CERAMIC 4.7UF-K/10V	D011475572200S		
C876D	nsp	C,CERAMIC 0.01UF-K/50V	D011103177101S		
C877D	nsp	C,CERAMIC 0.1UF-K/50V	D011104177101S		
C878D	nsp	C,CERAMIC 0.1UF-K/50V	D011104177101S		
C879D	nsp	C,CERAMIC 0.1UF-K/50V	D011104177101S		
C880D	nsp	C,CERAMIC 0.01UF-K/50V	D011103177101S		
C881D	nsp	C,CERAMIC 0.01UF-K/50V	D011103177101S		
C882D	nsp	C,CERAMIC 6PF-D/50V	D010060117160S		
C883D	nsp	C,CERAMIC 6PF-D/50V	D010060117160S		
C884D	nsp	C,CERAMIC 0.1UF-K/50V	D011104577162S		
C885D	nsp	C,CERAMIC 0.022UF-Z/50V	D011223597160S		
C886D	nsp	C,CERAMIC 0.1UF-K/50V	D011104177101S		
C887D	nsp	C,FILM 0.12UF-J/63V	D020124078060S		
C888D	nsp	C,CERAMIC 0.01UF-K/50V	D011103177101S		
C889D	nsp	C,CERAMIC 100PF-J/50V	D011101167101S		
C890D	nsp	C,CERAMIC 0.01UF-K/50V	D011103177101S		
C891D	nsp	C,CERAMIC 0.01UF-K/50V	D011103177101S		
C892D	nsp	C,CERAMIC 4.7UF-K/10V	D011475572200S		
C893D	nsp	C,CERAMIC 0.1UF-K/50V	D011104177101S		
C895D	nsp	C,CERAMIC 0.1UF-K/50V	D011104177101S		
C896D	nsp	C,CERAMIC 0.01UF-K/50V	D011103177101S		
C897D	nsp	C,CERAMIC 0.1UF-K/50V	D011104177101S		
C898D	nsp	C,CERAMIC 0.1UF-K/50V	D011104177101S		
C899D	nsp	C,CERAMIC 100PF-J/50V	D011101167101S		
C900D	nsp	C,CERAMIC 4.7UF-K/10V	D011475572200S		
C901D	nsp	C,ELECT 100UF-MVG/6.3V	D050101081650S		
C902D	nsp	C,CERAMIC 0.1UF-K/50V	D011104177101S		
C903D	nsp	C,CERAMIC 0.1UF-K/50V	D011104177101S		
C904D	nsp	C,CERAMIC 5600PF-K/50V	D011562777160S		
C905D	nsp	C,CERAMIC 390PF-J/50V	D010391167160S		
C906D	nsp	C,CERAMIC 0.1UF-K/50V	D011104177101S		

Ref. No.	Part No.	Part Name	Remarks	Q'ty	New
C907D	nsp	C,CERAMIC 0.1UF-K/50V	D011104177101S		
C908D	nsp	C,ELECT 47UF-MVG/6.3V	D050470081460S		
C909D	nsp	C,CERAMIC 0.1UF-K/50V	D011104177101S		
C910D	nsp	C,ELECT 10UF-MVG/16V	D050100083460S		
C911D	nsp	C,CERAMIC 0.01UF-K/50V	D011103177101S		
C913D	nsp	C,ELECT 10UF-MVG/16V	D050100083460S		
C914D	nsp	C,CERAMIC 0.01UF-K/50V	D011103177101S		
C915D	nsp	C,ELECT 10UF-MVG/16V	D050100083460S		
OTHERS PARTS GROUP					
BD801	nsp	COIL,BEAD MB-160808	D340160800060S		
BD807D	nsp	COIL,BEAD MB-160808	D340160800060S		
BD808D-03	nsp	COIL,BEAD MB-160808	D340160800060S		
CB06	nsp	COIL,BEAD MB-160808	D340160800060S		
CN01	nsp	CN.WAFER 16P	L101100031610S		
CN802	nsp	CN.HOUSING 16P	L120912160010S		
CN803	nsp	CN.WAFER 16P	L101100031610S		
CN804	nsp	CN.HOUSING 15P	L120912150010S		
CN805	nsp	CN.HOUSING 08P	L120912080010S		
CP201	nsp	CN.WAFER 9P	L101220090000S		
CP404	nsp	CN.WAFER 4P	L101220040000S		
CP405	nsp	CN.WAFER 5P	L101220050000S		
CP904	nsp	CN.WAFER 6P	L101220060010S		
J806	nsp	R,CHIP THICK 0-J,1/16W	C20000006M101S		
JACK01-03	00D 963 0388 504	19PIN HDMI CONNECTOR	L109100190020S		
TP801	nsp	CN.WAFER 13P	L101530141310S		
X01	nsp	CRYSTAL FCX-02(45.1584MHz)	E80545R150010S		
X803D	nsp	FCX-03(16.660MHz)	00D3991091905		
X804D	nsp	FCX-03(24.576MHz)	00D3991053901		

VIDEO P.W.B. UNIT ASS'Y

Ref. No.	Part No.	Part Name	Remarks	Q'ty	New
SEMICONDUCTORS GROUP					
IC1301	00D 960 0175 200	IC BA7625	J171762500000S		
IC1302,1303	00D 963 0083 304	IC BA7626	J171762600000S		
IC1304	00D 960 0239 104	IC KIA7806API	J126780600130S		
IC1305-1307	00D 963 0148 401	IC LA7956	J171795600010S		
Q1301-1303	00D 960 0005 105	TR KTA1266Y	J5001266Y0050S		
Q1304,1305	00D 960 0005 202	TR KTC3198Y	J5023198Y0000S		
Q1306-1309	00D 963 0121 208	TR KRC107M	J6020107M0010S		
Q1310-1313	00D 960 0005 202	TR KTC3198Y	J5023198Y0000S		
Q1314-1317	00D 963 0121 208	TR KRC107M	J6020107M0010S		
D1301	00D 963 0355 401	D,SWITCHING KDS4148U	K005041480030S		
D1302-1305	00D 276 0401 905	D,SWITCHING 1SS133T	K000013300520S		
D1306,1307	00D 963 0355 401	D,SWITCHING KDS4148U	K005041480030S		
CAPACITORS GROUP					
C1301-1309	00D 960 9010 010	C,ELECT 4.7UF-M/50V	D0404R7087250S		
C1310	00D 963 9005 969	C,ELECT 4700UF-M/6.3V	D040472081000S		
C1311,1312	00D 960 0298 802	C,ELECT 470UF-M/6.3V	D040471081070S		
C1313-1315	00D 963 0311 607	C,ELECT 100UF-M/10V (Pb Free)	D040101082090S		
C1316-1321	00D 963 0293 602	C,ELECT 1UF-M/50V (Pb Free)	D040010087150S		
C1322	nsp	C,CERAMIC 0.022UF-K/25V	D011223777160S		
C1323	00D 963 0311 607	C,ELECT 100UF-M/10V (Pb Free)	D040101082090S		
C1324	nsp	C,CERAMIC 0.022UF-K/25V	D011223777160S		
C1326	nsp	C,CERAMIC 0.022UF-K/25V	D011223777160S		
C1328	00D 963 0234 205	C,ELECT 10UF-M/50V	D040100087070S		
C1329	00D 963 0234 506	C,ELECT 47UF-M/50V (Pb Free)	D040470087070S		
C1330	00D 963 0234 205	C,ELECT 10UF-M/50V	D040100087070S		
C1331-1339	00D 963 9005 862	C,ELECT 47UF-M/16V	D040470083080S		
C1340-1345	00D 963 9005 901	C,ELECT 470UF-M/10V,6.3*11	D040471082060S		
C1347	nsp	C,CERAMIC 0.047UF-Z/50V	D011473597160S		
C1348	00D 960 9009 924	C,ELECT 100UF-M/16V	D040101083070S		
C1349,1350	nsp	C,CERAMIC 0.047UF-Z/50V	D011473597160S		
C1351,1352	00D 963 0293 602	C,ELECT 1UF-M/50V (Pb Free)	D040010087150S		
OTHERS PARTS GROUP					
CN406	nsp	CN,WIRE 300MM/3P	L000301030060S		
CN1301	nsp	CN.WAFER 5P	L101220050010S		
CN1303	nsp	CN.WAFER 8P	L101100030810S		
CP1302	nsp	CN.WAFER 9P	L101100030910S		
JACK1301	00D 963 0218 001	TER,RCA 2PIN	G60122001000YS		
JACK1302	00D 963 0218 108	TER,RCA 3PIN	G60630401000YS		
JACK1303,1304	00D 963 0367 709	TER,RCA 6PIN	G603610D0032YS		
	nsp	HEAT SINK	2120044338010S		
	nsp	SCREW,TAP TITE +2S 3*8 B-TYPE ZNW/BH	B020030081B10S		

HDMI_PWR P.W.B. UNIT ASS'Y

Ref. No.	Part No.	Part Name	Remarks	Q'ty	New
SEMICONDUCTORS GROUP					
IC401H1	00D 963 0366 500	IC KIA1117PI33		J126111733050S	
CAPACITORS GROUP					
C405H1	00D 963 0234 205	C,ELECT 10UF-M/50V		D040100087070S	
C406H1	00D 963 0233 303	C,CERAMIC 0.01UF-M/16V		D005103773530S	
OTHERS PARTS GROUP					
CN404	nsp	CN,WIRE 300MM/4P		L000301040110S	
CP513	nsp	CN.WAFER 3P ANGLE		L102526803010S	

PARTS LIST OF P.W.B. UNIT



AVR-1508 EUT MODEL

* 本表に "nsp" と記載されている部品は供給できません。

* Parts for which "nsp" is indicated on this table cannot be supplied.

* 本表に記載されている部品は、補修用部品のため製品に使用している部品とは一部、形状、寸法などが異なる場合があります。

* The parts listed below are for maintenance only, might differ from the parts used in the unit in appearances or dimensions.

MAIN P.W.B. UNIT ASS'Y

Ref. No.	Part No.	Part Name	Remarks	Q'ty	New
SEMICONDUCTORS GROUP					
	IC110,111	00D 963 0218 807	IC BU4094BCF-E2	J040140940030S	
	Q101	00D 960 0196 302	TR KTA1268BL	J5001268B0050S	
	Q102-104	00D 960 0196 700	TR KTC3200BL	J5023200B0050S	
	Q104C	00D 960 0196 506	TR KSC1845F	J5021845F0000S	
	Q104FL	00D 960 0196 506	TR KSC1845F	J5021845F0000S	
	Q104FR	00D 960 0196 506	TR KSC1845F	J5021845F0000S	
	Q104SL	00D 960 0196 506	TR KSC1845F	J5021845F0000S	
	Q104SR	00D 960 0196 506	TR KSC1845F	J5021845F0000S	
	Q105	00D 960 0196 700	TR KTC3200BL	J5023200B0050S	
	Q105C	00D 960 0196 603	TR KTC2874B	J502287400010S	
	Q105FL	00D 960 0196 603	TR KTC2874B	J502287400010S	
	Q105FR	00D 960 0196 603	TR KTC2874B	J502287400010S	
	Q105SL	00D 960 0196 603	TR KTC2874B	J502287400010S	
	Q105SR	00D 960 0196 603	TR KTC2874B	J502287400010S	
	Q106	00D 960 0196 700	TR KTC3200BL	J5023200B0050S	
	Q106C	00D 960 0196 205	TR KSA992F	J5000992F0050S	
	Q106FL	00D 960 0196 205	TR KSA992F	J5000992F0050S	
	Q106FR	00D 960 0196 205	TR KSA992F	J5000992F0050S	
	Q106SL	00D 960 0196 205	TR KSA992F	J5000992F0050S	
	Q106SR	00D 960 0196 205	TR KSA992F	J5000992F0050S	
	Q107	00D 960 0196 700	TR KTC3200BL	J5023200B0050S	
	Q107C	00D 960 0196 205	TR KSA992F	J5000992F0050S	
	Q107FL	00D 960 0196 205	TR KSA992F	J5000992F0050S	
	Q107FR	00D 960 0196 205	TR KSA992F	J5000992F0050S	
	Q107SL	00D 960 0196 205	TR KSA992F	J5000992F0050S	
	Q107SR	00D 960 0196 205	TR KSA992F	J5000992F0050S	
	Q108	00D 960 0196 700	TR KTC3200BL	J5023200B0050S	
	Q108C	00D 960 0196 506	TR KSC1845F	J5021845F0000S	
	Q108FL	00D 960 0196 506	TR KSC1845F	J5021845F0000S	
	Q108FR	00D 960 0196 506	TR KSC1845F	J5021845F0000S	
	Q108SL	00D 960 0196 506	TR KSC1845F	J5021845F0000S	
	Q108SR	00D 960 0196 506	TR KSC1845F	J5021845F0000S	
	Q109,110	00D 960 0196 700	TR KTC3200BL	J5023200B0050S	
	Q111	00D 960 0196 302	TR KTA1268BL	J5001268B0050S	
	Q130	00D 960 0196 302	TR KTA1268BL	J5001268B0050S	
	Q131,132	00D 963 0219 602	TR KRC106M	J6020106M0010S	
	Q133-137	00D 960 0097 207	TR KRA102M	J6002202M0010S	
	Q141SW	00D 963 0044 301	TR KTC2875B(MB)	J5222875B0010S	
	Q142	00D 960 0196 700	TR KTC3200BL	J5023200B0050S	
	Q142SW	00D 963 0044 301	TR KTC2875B(MB)	J5222875B0010S	
	Q143,144	00D 960 0196 302	TR KTA1268BL	J5001268B0050S	
	Q145	00D 960 0196 700	TR KTC3200BL	J5023200B0050S	
	Q146,147	00D 960 0196 302	TR KTA1268BL	J5001268B0050S	
	Q151	00D 960 0196 302	TR KTA1268BL	J5001268B0050S	
	Q156	00D 960 0097 304	TR KRC102M	J6020102M0010S	
	Q165	00D 960 0196 700	TR KTC3200BL	J5023200B0050S	
	Q166-171	00D 960 0196 302	TR KTA1268BL	J5001268B0050S	

Ref. No.	Part No.	Part Name	Remarks	Q'ty	New
Q541	00D 963 0121 208	TR KRC107M	J6020107M0010S		
D101C	00D 963 0355 401	D,SWITCHING KDS4148U	K005041480030S		
D101FL	00D 963 0355 401	D,SWITCHING KDS4148U	K005041480030S		
D101FR	00D 963 0355 401	D,SWITCHING KDS4148U	K005041480030S		
D101SL	00D 963 0355 401	D,SWITCHING KDS4148U	K005041480030S		
D101SR	00D 963 0355 401	D,SWITCHING KDS4148U	K005041480030S		
D102C	00D 963 0355 401	D,SWITCHING KDS4148U	K005041480030S		
D102FL	00D 963 0355 401	D,SWITCHING KDS4148U	K005041480030S		
D102FR	00D 963 0355 401	D,SWITCHING KDS4148U	K005041480030S		
D102SL	00D 963 0355 401	D,SWITCHING KDS4148U	K005041480030S		
D102SR	00D 963 0355 401	D,SWITCHING KDS4148U	K005041480030S		
D105C	00D 963 0020 309	D,SWITCHING 1SS133T	K000013300520S		
D105FL	00D 963 0020 309	D,SWITCHING 1SS133T	K000013300520S		
D105FR	00D 963 0020 309	D,SWITCHING 1SS133T	K000013300520S		
D105SL	00D 963 0020 309	D,SWITCHING 1SS133T	K000013300520S		
D105SR	00D 963 0020 309	D,SWITCHING 1SS133T	K000013300520S		
D106,107	00D 963 0355 401	D,SWITCHING KDS4148U	K005041480030S		
D114,115	00D 960 0197 107	D,RECTIFIER BRIDGE KBPC604	K047604000020S		
D139	00D 963 0020 309	D,SWITCHING 1SS133T	K000013300520S		
D140,141	00D 963 0328 409	D,SWITCHING 1N4007	K000400700010S		
D142	00D 963 0355 401	D,SWITCHING KDS4148U	K005041480030S		
D143-152	00D 963 0020 309	D,SWITCHING 1SS133T	K000013300520S		
D153	00D 963 0355 401	D,SWITCHING KDS4148U	K005041480030S		
D154-157	00D 963 0020 309	D,SWITCHING 1SS133T	K000013300520S		
D541	00D 963 0355 401	D,SWITCHING KDS4148U	K005041480030S		
ZD101	00D 963 0058 601	D,ZENER MTZJ12B	K06012R044520S		
ZD101C	00D 963 0367 008	D,ZENER 0.2W 3.3V UDZ	K06603R34P400S		
ZD101FL	00D 963 0367 008	D,ZENER 0.2W 3.3V UDZ	K06603R34P400S		
ZD101FR	00D 963 0367 008	D,ZENER 0.2W 3.3V UDZ	K06603R34P400S		
ZD101SL	00D 963 0367 008	D,ZENER 0.2W 3.3V UDZ	K06603R34P400S		
ZD101SR	00D 963 0367 008	D,ZENER 0.2W 3.3V UDZ	K06603R34P400S		
ZD102C	00D 963 0367 008	D,ZENER 0.2W 3.3V UDZ	K06603R04P400S		
ZD102FL	00D 963 0367 008	D,ZENER 0.2W 3.3V UDZ	K06603R04P400S		
ZD102FR	00D 963 0367 008	D,ZENER 0.2W 3.3V UDZ	K06603R04P400S		
ZD102SL	00D 963 0367 008	D,ZENER 0.2W 3.3V UDZ	K06603R04P400S		
ZD102SR	00D 963 0367 008	D,ZENER 0.2W 3.3V UDZ	K06603R04P400S		
ZD105	00D 960 0095 500	D,ZENER MTZJ5.1B	K06005R144520S		
RESISTORS GROUP					
R101	00D 963 0337 801	R,METAL FILM 100-J,2W	C060010166520S		
R103	00D 963 9005 639	R,METAL FILM 100-J,1W	C060010165060S		
R104	00D 963 0215 907	R,METAL FILM 4.7-J,1W	C0604R7065050S		
R104C	00D 963 9006 285	R,FIXED 1WJ-5.6K	N113135656220S		
R104FL	00D 963 9006 285	R,FIXED 1WJ-5.6K	N113135656220S		
R104FR	00D 963 9006 285	R,FIXED 1WJ-5.6K	N113135656220S		
R104SL	00D 963 9006 285	R,FIXED 1WJ-5.6K	N113135656220S		
R104SR	00D 963 9006 285	R,FIXED 1WJ-5.6K	N113135656220S		
R105	00D 963 0232 906	R,METAL FILM 47K-F,1/4W	C060047343530S		
R105C	00D 963 9006 285	R,FIXED 1WJ-5.6K	N113135656220S		
R105FL	00D 963 9006 285	R,FIXED 1WJ-5.6K	N113135656220S		
R105FR	00D 963 9006 285	R,FIXED 1WJ-5.6K	N113135656220S		
R105SL	00D 963 9006 285	R,FIXED 1WJ-5.6K	N113135656220S		
R105SR	00D 963 9006 285	R,FIXED 1WJ-5.6K	N113135656220S		

Ref. No.	Part No.	Part Name	Remarks	Q'ty	New
R106C	00D 963 0215 907	R,METAL FILM 4.7-J,1W	C0604R7065050S		
R106FL	00D 963 0215 907	R,METAL FILM 4.7-J,1W	C0604R7065050S		
R106FR	00D 963 0215 907	R,METAL FILM 4.7-J,1W	C0604R7065050S		
R106SL	00D 963 0215 907	R,METAL FILM 4.7-J,1W	C0604R7065050S		
R106SR	00D 963 0215 907	R,METAL FILM 4.7-J,1W	C0604R7065050S		
R107C	00D 963 0215 907	R,METAL FILM 4.7-J,1W	C0604R7065050S		
R107FL	00D 963 0215 907	R,METAL FILM 4.7-J,1W	C0604R7065050S		
R107FR	00D 963 0215 907	R,METAL FILM 4.7-J,1W	C0604R7065050S		
R107SL	00D 963 0215 907	R,METAL FILM 4.7-J,1W	C0604R7065050S		
R107SR	00D 963 0215 907	R,METAL FILM 4.7-J,1W	C0604R7065050S		
R108C	00D 963 0345 903	R,FIXED 2WJ-0.47	N113136647820S		
R108FL	00D 963 0345 903	R,FIXED 2WJ-0.47	N113136647820S		
R108FR	00D 963 0345 903	R,FIXED 2WJ-0.47	N113136647820S		
R108SL	00D 963 0345 903	R,FIXED 2WJ-0.47	N113136647820S		
R108SR	00D 963 0345 903	R,FIXED 2WJ-0.47	N113136647820S		
R109C	00D 963 0345 903	R,FIXED 2WJ-0.47	N113136647820S		
R109FL	00D 963 0345 903	R,FIXED 2WJ-0.47	N113136647820S		
R109FR	00D 963 0345 903	R,FIXED 2WJ-0.47	N113136647820S		
R109SL	00D 963 0345 903	R,FIXED 2WJ-0.47	N113136647820S		
R109SR	00D 963 0345 903	R,FIXED 2WJ-0.47	N113136647820S		
R110C	00D 963 0345 903	R,FIXED 2WJ-0.47	N113136647820S		
R110FL	00D 963 0345 903	R,FIXED 2WJ-0.47	N113136647820S		
R110FR	00D 963 0345 903	R,FIXED 2WJ-0.47	N113136647820S		
R110SL	00D 963 0345 903	R,FIXED 2WJ-0.47	N113136647820S		
R110SR	00D 963 0345 903	R,FIXED 2WJ-0.47	N113136647820S		
R111C	00D 963 0345 903	R,FIXED 2WJ-0.47	N113136647820S		
R111FL	00D 963 0345 903	R,FIXED 2WJ-0.47	N113136647820S		
R111FR	00D 963 0345 903	R,FIXED 2WJ-0.47	N113136647820S		
R111SL	00D 963 0345 903	R,FIXED 2WJ-0.47	N113136647820S		
R111SR	00D 963 0345 903	R,FIXED 2WJ-0.47	N113136647820S		
R117,118	00D 963 0144 502	R,CEMENT 0.1-J 5W	C141R10069000S		
R118C	00D 963 9006 256	R,FIXED 1WJ-10	N113135610020S		
R118FL	00D 963 9006 256	R,FIXED 1WJ-10	N113135610020S		
R118FR	00D 963 9006 256	R,FIXED 1WJ-10	N113135610020S		
R118SL	00D 963 9006 256	R,FIXED 1WJ-10	N113135610020S		
R118SR	00D 963 9006 256	R,FIXED 1WJ-10	N113135610020S		
R119C	00D 963 9006 256	R,FIXED 1WJ-10	N113135610020S		
R119FL	00D 963 9006 256	R,FIXED 1WJ-10	N113135610020S		
R119FR	00D 963 9006 256	R,FIXED 1WJ-10	N113135610020S		
R119SL	00D 963 9006 256	R,FIXED 1WJ-10	N113135610020S		
R119SR	00D 963 9006 256	R,FIXED 1WJ-10	N113135610020S		
R127C	00D 963 9005 642	R,METAL FILM 1.2K-J,1W	C060012265050S		
R127FL	00D 963 9005 642	R,METAL FILM 1.2K-J,1W	C060012265050S		
R127FR	00D 963 9005 642	R,METAL FILM 1.2K-J,1W	C060012265050S		
R127SL	00D 963 9005 642	R,METAL FILM 1.2K-J,1W	C060012265050S		
R127SR	00D 963 9005 642	R,METAL FILM 1.2K-J,1W	C060012265050S		
R132C	00D 960 9010 719	R,METAL FILM 47-J,1W	C060047065060S		
R132FL	00D 960 9010 719	R,METAL FILM 47-J,1W	C060047065060S		
R132FR	00D 960 9010 719	R,METAL FILM 47-J,1W	C060047065060S		
R132SL	00D 960 9010 719	R,METAL FILM 47-J,1W	C060047065060S		
R132SR	00D 960 9010 719	R,METAL FILM 47-J,1W	C060047065060S		
R147-149	00D 963 9005 642	R,METAL FILM 1.2K-J,1W	C060012265050S		
VR101C	00D 960 0221 109	VR,SEMI CARBON EVN-DJAA03B	C541102115000S		
VR101FL	00D 960 0221 109	VR,SEMI CARBON EVN-DJAA03B	C541102115000S		
VR101FR	00D 960 0221 109	VR,SEMI CARBON EVN-DJAA03B	C541102115000S		

Ref. No.	Part No.	Part Name	Remarks	Q'ty	New
VR101SL VR101SR	00D 960 0221 109 00D 960 0221 109	VR,SEMI CARBON EVN-DJAA03B VR,SEMI CARBON EVN-DJAA03B	C541102115000S C541102115000S		
CAPACITORS GROUP					
C101 C101C C101FL C101FR	00D 963 9005 804 00D 963 0234 506 00D 963 0234 506 00D 963 0234 506	C,ELECT 100UF-M/25V C,ELECT 47UF-M/50V (Pb Free) C,ELECT 47UF-M/50V (Pb Free) C,ELECT 47UF-M/50V (Pb Free)	D040101084060S D040470087070S D040470087070S D040470087070S		
C101SL C101SR C102 C102C C102FL	00D 963 0234 506 00D 963 0234 506 00D 963 0224 503 00D 963 0234 205 00D 960 9010 133	C,ELECT 47UF-M/50V (Pb Free) C,ELECT 47UF-M/50V (Pb Free) C,ELECT 22UF-M/50V C,ELECT 10UF-M/50V C,ELECT 220UF-M/35V	D040470087070S D040470087070S D040220087060S D040100087070S D040221085060S		
C102FR C102SL C102SR C103 C103C	00D 960 9010 133 00D 963 0234 205 00D 963 0234 205 00D 963 9006 557 00D 963 9003 084	C,ELECT 220UF-M/35V C,ELECT 10UF-M/50V C,ELECT 10UF-M/50V C,ELECT 220UF-M/6.3V C,CERAMIC 100PF-K/500V	D040221085060S D040100087070S D040100087070S D040221081060S D00410106D050S		
C103FL C103FR C103SL C103SR C104	00D 963 9003 084 00D 963 9003 084 00D 963 9003 084 00D 963 9003 084 00D 963 9006 557	C,CERAMIC 100PF-K/500V C,CERAMIC 100PF-K/500V C,CERAMIC 100PF-K/500V C,CERAMIC 100PF-K/500V C,ELECT 220UF-M/6.3V	D00410106D050S D00410106D050S D00410106D050S D00410106D050S D040221081060S		
C104C C104FL C104FR C104SL C104SR	00D 963 9003 084 00D 963 9003 084 00D 963 9003 084 00D 963 9003 084 00D 963 9003 084	C,CERAMIC 100PF-K/500V C,CERAMIC 100PF-K/500V C,CERAMIC 100PF-K/500V C,CERAMIC 100PF-K/500V C,CERAMIC 100PF-K/500V	D00410106D050S D00410106D050S D00410106D050S D00410106D050S D00410106D050S		
C105 C105C C105FL C105FR C105SL	00D 963 9006 557 nsp nsp nsp nsp	C,ELECT 220UF-M/6.3V C,CERAMIC 0.022UF-Z/50V C,CERAMIC 0.022UF-Z/50V C,CERAMIC 0.022UF-Z/50V C,CERAMIC 0.022UF-Z/50V	D040221081060S D011223597160S D011223597160S D011223597160S D011223597160S		
C105SR C106 C107 C107C C107FL	nsp 00D 963 0293 709 nsp 00D 963 9003 097 00D 963 9003 097	C,CERAMIC 0.022UF-Z/50V C,ELECT 100UF-M/10V C,CERAMIC 0.01UF-K/50V C,FILM 0.1UF-K/250V C,FILM 0.1UF-K/250V	D011223597160S D040101082070S D011103777160S D02010407H080S D02010407H080S		
C107FR C107SL C107SR C108 C108C	00D 963 9003 097 00D 963 9003 097 00D 963 9003 097 00D 963 0149 400 00D 963 9006 544	C,FILM 0.1UF-K/250V C,FILM 0.1UF-K/250V C,FILM 0.1UF-K/250V CAP.E.GENERIC 10000UF/63V C,ELECT 22UF-M/25V	D02010407H080S D02010407H080S D02010407H080S N211210388110S D040220084050S		
C108FL C108FR C108SL C108SR C109	00D 963 9006 544 00D 963 9006 544 00D 963 9006 544 00D 963 9006 544 00D 963 0149 400	C,ELECT 22UF-M/25V C,ELECT 22UF-M/25V C,ELECT 22UF-M/25V C,ELECT 22UF-M/25V CAP.E.GENERIC 10000UF/63V	D040220084050S D040220084050S D040220084050S D040220084050S N211210388110S		
C109C C109FL C109FR C109SL C109SR	00D 963 0234 205 00D 963 0234 205 00D 963 0234 205 00D 963 0234 205 00D 963 0234 205	C,ELECT 10UF-M/50V C,ELECT 10UF-M/50V C,ELECT 10UF-M/50V C,ELECT 10UF-M/50V C,ELECT 10UF-M/50V	D040100087070S D040100087070S D040100087070S D040100087070S D040100087070S		
C110 C110C	00D 963 9003 097 00D 963 0338 208	C,FILM 0.1UF-K/250V C,CERAMIC 470PF-K/500V	D02010407H080S D00447127D050S		

Ref. No.	Part No.	Part Name	Remarks	Q'ty	New
C110FL	00D 963 0338 208	C,CERAMIC 470PF-K/500V	D00447127D050S		
C110FR	00D 963 0338 208	C,CERAMIC 470PF-K/500V	D00447127D050S		
C110SL	00D 963 0338 208	C,CERAMIC 470PF-K/500V	D00447127D050S		
C110SR	00D 963 0338 208	C,CERAMIC 470PF-K/500V	D00447127D050S		
C111	00D 963 9003 097	C,FILM 0.1UF-K/250V	D02010407H080S		
C111C	00D 963 0367 101	C,CERAMIC 220PF-J/500V	D00422106D05CS		
C111FL	00D 963 0367 101	C,CERAMIC 220PF-J/500V	D00422106D05CS		
C111FR	00D 963 0367 101	C,CERAMIC 220PF-J/500V	D00422106D05CS		
C111SL	00D 963 0367 101	C,CERAMIC 220PF-J/500V	D00422106D05CS		
C111SR	00D 963 0367 101	C,CERAMIC 220PF-J/500V	D00422106D05CS		
C112	00D 963 9003 097	C,FILM 0.1UF-K/250V	D02010407H080S		
C112C	00D 963 9003 194	C,FILM 0.0022UF-J/100V	D02022206C060S		
C112FL	00D 963 9003 194	C,FILM 0.0022UF-J/100V	D02022206C060S		
C112FR	00D 963 9003 194	C,FILM 0.0022UF-J/100V	D02022206C060S		
C112SL	00D 963 9003 194	C,FILM 0.0022UF-J/100V	D02022206C060S		
C112SR	00D 963 9003 194	C,FILM 0.0022UF-J/100V	D02022206C060S		
C113C	00D 963 0293 709	C,ELECT 100UF-M/10V	D040101082070S		
C113FL	00D 960 9010 133	C,ELECT 220UF-M/35V	D040221085060S		
C113FR	00D 960 9010 133	C,ELECT 220UF-M/35V	D040221085060S		
C113SL	00D 963 0293 709	C,ELECT 100UF-M/10V	D040101082070S		
C113SR	00D 963 0293 709	C,ELECT 100UF-M/10V	D040101082070S		
C114	00D 963 9003 097	C,FILM 0.1UF-K/250V	D02010407H080S		
C114C	00D 963 0216 100	C,CERAMIC 33PF-J/500V	D00033006D050S		
C114FL	00D 963 0216 100	C,CERAMIC 33PF-J/500V	D00033006D050S		
C114FR	00D 963 0216 100	C,CERAMIC 33PF-J/500V	D00033006D050S		
C114SL	00D 963 0216 100	C,CERAMIC 33PF-J/500V	D00033006D050S		
C114SR	00D 963 0216 100	C,CERAMIC 33PF-J/500V	D00033006D050S		
C115	00D 963 9003 097	C,FILM 0.1UF-K/250V	D02010407H080S		
C115SW	00D 963 9006 544	C,ELECT 22UF-M/25V	D040220084050S		
C117-120	nsp	C,CERAMIC 0.1UF-K/50V	D011104577160S		
C141SW1	00D 963 0234 205	C,ELECT 10UF-M/50V	D040100087070S		
C142SW1	nsp	C,CERAMIC 100PF-J/50V	D010101167160S		
C161	00D 963 0234 205	C,ELECT 10UF-M/50V	D040100087070S		
C162,163	nsp	C,CERAMIC 0.01UF-K/50V	D011103777160S		
C164	nsp	C,CERAMIC 100PF-J/50V	D010101167160S		
C166,167	nsp	C,CERAMIC 100PF-J/50V	D010101167160S		
C168-172	00D 963 0244 606	C,ELECT 0.1UF-M/50V (Pb Free)	D040R10087080S		
C177	nsp	C,CERAMIC 0.01UF-K/50V	D011103777160S		
C178,179	00D 960 9010 010	C,ELECT 4.7UF-M/50V	D0404R7087250S		
C180,181	nsp	C,CERAMIC 0.01UF-K/50V	D011103777160S		
C182	00D 963 0324 005	C,ELECT 100UF-M/100V	D04010108C240S		
C183	00D 963 0293 602	C,ELECT 1UF-M/50V (Pb Free)	D040010087150S		
C190	00D 960 9010 010	C,ELECT 4.7UF-M/50V	D0404R7087250S		
OTHERS PARTS GROUP					
BKT101	nsp	SHIELD PLATE GND	3070045526010S		
CN101	nsp	CN,WIRE 110MM/10P	L000111100070S		
CN103	nsp	CN,WIRE 120MM/7P	L000121070060S		
CN201	nsp	CN,WIRE 70MM/6P	L000700060110S		
CN511	nsp	CN,WIRE 60MM/9P	L000600090020S		
CN704	nsp	CN,WIRE 15P	L000600150030S		
CP103	nsp	CN.WAFER 3P	L102526700300S		
CP104	nsp	CN.WAFER 3CKT	L108353280360S		

Ref. No.	Part No.	Part Name	Remarks	Q'ty	New
CP106	nsp	CN.WAFER 5P	L101100040510S		
CP107	nsp	CN.WAFER 3P	L102526700300S		
CP108	nsp	CN.WAFER 17P	L101100041710S		
CP541	nsp	CN.WAFER 3P	L101220030000S		
GND101	nsp	TERMINAL EARTH	3790040886000S		
JACK222	00D 963 0146 005	TER,RCA 1PIN	G600107A0000YS		
L101C	00D 963 0049 005	COIL INDUCTOR 0.5UH	D330R50000000S		
L101FL	00D 963 0049 005	COIL INDUCTOR 0.5UH	D330R50000000S		
L101FR	00D 963 0049 005	COIL INDUCTOR 0.5UH	D330R50000000S		
L101SL	00D 963 0049 005	COIL INDUCTOR 0.5UH	D330R50000000S		
L101SR	00D 963 0049 005	COIL INDUCTOR 0.5UH	D330R50000000S		
RLY541	00D 963 0218 506	RELAY BC3-24 24V 2A	G680240202040S		
TP101-105	nsp	CN.WAFER 3P	L101530140310S		
JP108	00D 963 0223 009	R,CHIP THICK 0-J,1/16W	C20000006M160S		
JP350-352	00D 963 0223 009	R,CHIP THICK 0-J,1/16W	C20000006M160S		

FRONT P.W.B. UNIT ASS'Y

Ref. No.	Part No.	Part Name	Remarks	Q'ty	New
SEMICONDUCTORS GROUP					
IC301	00D 963 0074 504	IC BU2090F-E2	J044209000010S		
IC302	00D 262 3758 009	LC87F6D64A-QFP-E	J127876160010S		
IC303	00D 960 0195 808	IC ICP-N15	J120001500030S		
Q301-303	00D 963 0120 704	TR KRA102S	J520010200210S		
Q304	00D 963 0121 606	TR KRC107S	J522107S00210S		
Q305	00D 963 0102 803	TR 2SA933S	J5000933S0050S		
Q306	00D 963 0120 801	TR KRC102S	J522010200210S		
Q307-309	00D 963 0120 704	TR KRA102S	J520010200210S		
Q310,311	00D 963 0120 801	TR KRC102S	J522010200210S		
Q312	00D 960 0133 103	TR KSA916Y	J5000916Y0050S		
Q542-546	00D 963 0121 208	TR KRC107M	J6020107M0010S		
D301,302	00D 963 0020 309	D,SWITCHING 1SS133T	K000013300520S		
D303	00D 963 0355 401	D,SWITCHING KDS4148U	K005041480030S		
D304	00D 963 0020 309	D,SWITCHING 1SS133T	K000013300520S		
D305-311	00D 963 0355 401	D,SWITCHING KDS4148U	K005041480030S		
D312	00D 963 0328 409	D,SWITCHING 1N4007	K000400700010S		
D313-316	00D 963 0355 401	D,SWITCHING KDS4148U	K005041480030S		
D542	00D 963 0020 309	D,SWITCHING 1SS133T	K000013300520S		
D543-545	00D 963 0355 401	D,SWITCHING KDS4148U	K005041480030S		
D546	00D 963 0020 309	D,SWITCHING 1SS133T	K000013300520S		
ZD302-305	00D 960 0095 500	D,ZENER MTZJ5.1B	K06005R144520S		
ZD307,308	00D 960 0095 500	D,ZENER MTZJ5.1B	K06005R144520S		
ZD309	00D 960 0095 801	D,ZENER MTZJ6.8B	K06006R844520S		
ZD310,311	00D 963 0046 202	D,ZENER MTZJ18B	K06018R044520S		
LED302-309	00D 960 0197 204	LED PI5-RD/HL50RDRF4T	K500052015010S		
LED310	00D 963 0366 108	LED BL-BEG204-L 5PI	K500052004010S		
FL301	00D 963 0257 305	DISPLAY,FLT HNA-16SM13T	K530161300020S		
RESISTORS GROUP					
R372	00D 963 0215 907	R,METAL FILM 4.7-J,1W	C0604R7065050S		
R378,379	00D 960 9009 270	R,METAL FILM 470-J,2W	C060047166520S		
R501	00D 960 9003 700	R,METAL FILM 10-J,1/4W	C060010063050S		
RP1-38	00D 963 0353 005	R,CHIP THICK 56K-J,1/16W	C20005636M160S		
RG1-16	00D 963 0353 005	R,CHIP THICK 56K-J,1/16W	C20005636M160S		
CAPACITORS GROUP					
C301,302	nsp	C,CERAMIC 100PF-J/50V	D010101167160S		
C303	nsp	C,CERAMIC 0.022UF-K/25V	D011223777160S		
C304	00D 963 9005 862	C,ELECT 47UF-M/16V	D040470083080S		
C305	nsp	C,CERAMIC 100PF-J/50V	D010101167160S		
C306	nsp	C,CERAMIC 0.047UF-Z/50V	D011473597160S		
C307	00D 963 9005 862	C,ELECT 47UF-M/16V	D040470083080S		
C308	nsp	C,CERAMIC 0.01UF-K/50V	D011103777160S		
C311	00D 963 0233 303	C,CERAMIC 0.01UF-M/16V	D005103773530S		
C312	00D 963 9005 862	C,ELECT 47UF-M/16V	D040470083080S		

Ref. No.	Part No.	Part Name	Remarks	Q'ty	New
C316,317	nsp	C,CERAMIC 330PF-J/50V	D010331167160S		
C319,320	nsp	C,CERAMIC 0.01UF-K/50V	D011103777160S		
C321,322	00D 963 0233 303	C,CERAMIC 0.01UF-M/16V	D005103773530S		
C324,325	00D 963 0293 602	C,ELECT 1UF-M/50V (Pb Free)	D040010087150S		
C326	00D 963 9005 862	C,ELECT 47UF-M/16V	D040470083080S		
C327,328	nsp	C,CERAMIC 0.1UF-K/50V	D011104577160S		
C329	nsp	C,FILM 0.1UF-J/100V	D02010406C060S		
C330	00D 963 0021 900	C,FILM 0.047UF-J/100V	D02047306C060S		
C333	00D 963 0293 602	C,ELECT 1UF-M/50V (Pb Free)	D040010087150S		
C334	00D 963 0021 900	C,FILM 0.047UF-J/100V	D02047306C060S		
C339	nsp	C,CERAMIC 100PF-J/50V	D010101167160S		
C340	nsp	C,CERAMIC 1000PF-K/50V	D011102777160S		
C341,342	nsp	C,CERAMIC 100PF-J/50V	D010101167160S		
C343	00D 963 0020 202	C,CERAMIC 0.1UF-Z/50V	D005104597530S		
C344,345	00D 963 0233 206	C,CERAMIC 0.001UF-K/50V	D005102177530S		
C346-349	nsp	C,CERAMIC 0.01UF-K/50V	D011103777160S		
C350	00D 963 0021 900	C,FILM 0.047UF-J/100V	D02047306C060S		
C351	00D 963 0293 602	C,ELECT 1UF-M/50V (Pb Free)	D040010087150S		
C352	00D 963 0234 205	C,ELECT 10UF-M/50V	D040100087070S		
C353,354	00D 963 0293 602	C,ELECT 1UF-M/50V (Pb Free)	D040010087150S		
C355	nsp	C,ELECT 470UF-M/63V	D040471088010S		
C356	00D 963 9003 097	C,FILM 0.1UF-K/250V	D02010407H080S		
C357,358	nsp	C,CERAMIC 0.047UF-Z/50V	D011473597160S		
C541	nsp	C,CERAMIC 2200PF-K/50V	D011222777160S		
C541FL	00D 963 0024 703	C,FILM 0.01UF-J/100V	D02010306C060S		
C542	nsp	C,CERAMIC 2200PF-K/50V	D011222777160S		
C542FR	00D 963 0024 703	C,FILM 0.01UF-J/100V	D02010306C060S		
C543	nsp	C,CERAMIC 2200PF-K/50V	D011222777160S		
C543FL	00D 963 0024 703	C,FILM 0.01UF-J/100V	D02010306C060S		
C544	nsp	C,CERAMIC 2200PF-K/50V	D011222777160S		
C544FR	00D 963 0024 703	C,FILM 0.01UF-J/100V	D02010306C060S		
C545	nsp	C,CERAMIC 2200PF-K/50V	D011222777160S		
C545C	00D 963 0024 703	C,FILM 0.01UF-J/100V	D02010306C060S		
C546	nsp	C,CERAMIC 2200PF-K/50V	D011222777160S		
C546SL	00D 963 0024 703	C,FILM 0.01UF-J/100V	D02010306C060S		
C547	nsp	C,CERAMIC 2200PF-K/50V	D011222777160S		
C547SR	00D 963 0024 703	C,FILM 0.01UF-J/100V	D02010306C060S		
C548	nsp	C,CERAMIC 2200PF-K/50V	D011222777160S		
C548SBL	00D 963 0024 703	C,FILM 0.01UF-J/100V	D02010306C060S		
C549	nsp	C,CERAMIC 2200PF-K/50V	D011222777160S		
C549SBR	00D 963 0024 703	C,FILM 0.01UF-J/100V	D02010306C060S		
OTHERS PARTS GROUP					
BD301-303	nsp	COIL,BEAD MB-160808	D340160800060S		
CN102	nsp	CN,WIRE 270,170MM/4P	L000271040040S		
CN301	nsp	CN,WIRE 2P	L000401020050S		
CN303A	nsp	CN,WIRE 8P	L000450080010S		
CN304	nsp	CN,WIRE 3P	L000500030050S		
CN305	nsp	CN,WIRE 10P	L000700100030S		
CN541	nsp	CN,WIRE 3P	L000251030080S		
CP101	nsp	CN.WAFER 14P	L102526701400S		
CP103	nsp	CN.WAFER 7P	L101220070010S		
CP105	nsp	CN.WAFER 4P ANGLE	L102526800400S		

Ref. No.	Part No.	Part Name	Remarks	Q'ty	New
CP301B	00D 963 0368 506	CN.FPC 35P	L131103500010S		
CP302	nsp	CN.WAFER 3P ANGLE	L102526803010S		
CP304	nsp	CN.WAFER 3P	L101220030000S		
CP305	nsp	CN.WAFER 10P	L101220100010S		
CP306	nsp	CN.WAFER 3P	L101220030010S		
G301	nsp	RING,TER WIRE 120MM/1P	8410121010060S		
G302	nsp	RING,TER WIRE 120MM/1P	8410121010110S		
G304	nsp	RING,TER WIRE 70MM/1P	8410700010070S		
JACK304	00D 963 0146 403	TER,RCA 3PIN	G606308HG110YS		
JACK501,502	00D 963 0146 607	TER,BOARD SCREW 8P	G614801A0200YS		
JACK503	00D 963 0158 608	TER,BOARD SCREW 2P	G611201A0200YS		
JK302	00D 963 0294 708	JACK,D6.5 PHONE	G402PJ612AG0YS		
L302	nsp	COIL INDUCTOR 10UH	D330100700520S		
L303	nsp	COIL INDUCTOR 100UH	D330101001020S		
RLY541	00D 963 0366 201	RELAY G5PA-28-MC 24V 5A	G680240502030S		
RLY543-546	00D 963 0366 201	RELAY G5PA-28-MC 24V 5A	G680240502030S		
RMC301	00D 963 0217 808	MODULE,REMOCON NJL34H380A	E940343800010S		
⚠ SW301	00D 963 0145 802	SW,PUSH SDDL-005-S(C-UL)	G000122006060S		
SW301A	00D 963 0095 305	SW,TACT SKHV10910D01	G180040500010S		
SW301C	00D 963 0095 305	SW,TACT SKHV10910D01	G180040500010S		
SW302A	00D 963 0095 305	SW,TACT SKHV10910D01	G180040500010S		
SW302B	00D 963 0095 305	SW,TACT SKHV10910D01	G180040500010S		
SW302C	00D 963 0095 305	SW,TACT SKHV10910D01	G180040500010S		
SW303A	00D 963 0095 305	SW,TACT SKHV10910D01	G180040500010S		
SW303B	00D 963 0095 305	SW,TACT SKHV10910D01	G180040500010S		
SW303C	00D 963 0095 305	SW,TACT SKHV10910D01	G180040500010S		
SW304A	00D 963 0095 305	SW,TACT SKHV10910D01	G180040500010S		
SW304B	00D 963 0095 305	SW,TACT SKHV10910D01	G180040500010S		
SW304C	00D 963 0095 305	SW,TACT SKHV10910D01	G180040500010S		
SW305A	00D 963 0095 305	SW,TACT SKHV10910D01	G180040500010S		
SW305B	00D 963 0095 305	SW,TACT SKHV10910D01	G180040500010S		
SW305C	00D 963 0095 305	SW,TACT SKHV10910D01	G180040500010S		
SW306A	00D 963 0095 305	SW,TACT SKHV10910D01	G180040500010S		
SW306B	00D 963 0095 305	SW,TACT SKHV10910D01	G180040500010S		
SW306C	00D 963 0095 305	SW,TACT SKHV10910D01	G180040500010S		
SW307A	00D 963 0095 305	SW,TACT SKHV10910D01	G180040500010S		
SW307B	00D 963 0095 305	SW,TACT SKHV10910D01	G180040500010S		
SW307C	00D 963 0095 305	SW,TACT SKHV10910D01	G180040500010S		
SW308A	00D 963 0095 305	SW,TACT SKHV10910D01	G180040500010S		
SW308B	00D 963 0095 305	SW,TACT SKHV10910D01	G180040500010S		
SW308C	00D 963 0095 305	SW,TACT SKHV10910D01	G180040500010S		
SW309A	00D 963 0095 305	SW,TACT SKHV10910D01	G180040500010S		
SW310	00D 963 0095 305	SW,TACT SKHV10910D01	G180040500010S		
VEC203	00D 963 0300 401	SW,ENCODER EC11B20C2	G121112020000S		
VEC301	00D 963 0095 305	SW,ENCODER EC16B24SO	G121162400070S		
VEC303	00D 963 0095 305	SW,ENCODER EC16B24SO	G121162400070S		
	nsp	HOLDER FLT	4320200026000S		

INPUT P.W.B. UNIT ASS'Y

Ref. No.	Part No.	Part Name	Remarks	Q'ty	New
SEMICONDUCTORS GROUP					
IC700	00D 963 0366 304	IC R2A15215FP		J084152150010S	
IC702	00D 963 0024 004	IC NJM2068M		J121206800020S	
IC705-718	00D 963 0024 004	IC NJM2068M		J121206800020S	
Q700,701	00D 960 0196 807	TR 2SK117Y		J5441170Y0050S	
Q702	00D 963 0120 704	TR KRA102S		J520010200210S	
Q703	00D 960 0285 006	TR KRC104S		J522104S00210S	
D700,701	00D 963 0355 401	D,SWITCHING KDS4148U		K005041480030S	
ZD700,701	00D 960 0222 603	D,ZENER MTZJ7.5A		K06007R544530S	
RESISTORS GROUP					
R706-709	00D 963 9005 639	R,METAL FILM 100-J,1W		C060010165060S	
R791VC	nsp	R,METAL FILM 120-J,1W		C060012165060S	
R791VE	nsp	R,METAL FILM 120-J,1W		C060012165060S	
CAPACITORS GROUP					
C700	00D 963 0234 205	C,ELECT 10UF-M/50V		D040100087070S	
C702SW	00D 960 9010 010	C,ELECT 4.7UF-M/50V		D0404R7087250S	
C703C	nsp	C,CERAMIC 0.047UF-Z/50V		D011473597160S	
C703SW	nsp	C,CERAMIC 0.047UF-Z/50V		D011473597160S	
C704,705	00D 963 9005 875	C,ELECT 47UF-M/25V		D040470084070S	
C706FL	00D 963 9005 875	C,ELECT 47UF-M/25V		D040470084070S	
C706FR	00D 963 9005 875	C,ELECT 47UF-M/25V		D040470084070S	
C707FL	00D 963 0234 205	C,ELECT 10UF-M/50V		D040100087070S	
C707FR	00D 963 0234 205	C,ELECT 10UF-M/50V		D040100087070S	
C707SW	00D 963 0234 205	C,ELECT 10UF-M/50V		D040100087070S	
C708FL	nsp	C,CERAMIC 33PF-J/50V		D010330167160S	
C708FR	nsp	C,CERAMIC 33PF-J/50V		D010330167160S	
C708SW	nsp	C,CERAMIC 47PF-J/50V		D010470167160S	
C709FL	nsp	C,CERAMIC 0.047UF-Z/50V		D011473597160S	
C709FR	nsp	C,CERAMIC 0.047UF-Z/50V		D011473597160S	
C709SW	nsp	C,CERAMIC 0.047UF-Z/50V		D011473597160S	
C710	00D 963 0223 009	R,CHIP THICK 0-J,1/16W		C20000006M160S	
C710FL	nsp	C,CERAMIC 100PF-J/50V		D010101167160S	
C710FR	nsp	C,CERAMIC 100PF-J/50V		D010101167160S	
C710SW	nsp	C,CERAMIC 100PF-J/50V		D010101167160S	
C711	00D 963 0223 009	R,CHIP THICK 0-J,1/16W		C20000006M160S	
C711FL	nsp	C,CERAMIC 0.047UF-Z/50V		D011473597160S	
C711FR	nsp	C,CERAMIC 0.047UF-Z/50V		D011473597160S	
C711SW	nsp	C,CERAMIC 0.047UF-Z/50V		D011473597160S	
C712	00D 963 0293 602	C,ELECT 1UF-M/50V (Pb Free)		D040010087150S	
C713-715	00D 963 0223 009	R,CHIP THICK 0-J,1/16W		C20000006M160S	
C716-727	00D 960 9009 814	C,CERAMIC 330PF-J/50V		D010331167160S	
C728-731	nsp	C,CERAMIC 20PF-J/50V		D010200167160S	
C732-739	00D 960 9009 814	C,CERAMIC 330PF-J/50V		D010331167160S	
C740-751	00D 963 0234 205	C,ELECT 10UF-M/50V		D040100087070S	
C751A	00D 963 0234 205	C,ELECT 10UF-M/50V		D040100087070S	
C751B	00D 963 0234 205	C,ELECT 10UF-M/50V		D040100087070S	
C751C	00D 963 0234 205	C,ELECT 10UF-M/50V		D040100087070S	
C751D	00D 963 0234 205	C,ELECT 10UF-M/50V		D040100087070S	

Ref. No.	Part No.	Part Name	Remarks	Q'ty	New
C751E	00D 963 0234 205	C,ELECT 10UF-M/50V	D040100087070S		
C751F	00D 963 0234 205	C,ELECT 10UF-M/50V	D040100087070S		
C751G	00D 963 0234 205	C,ELECT 10UF-M/50V	D040100087070S		
C751H	00D 963 0234 205	C,ELECT 10UF-M/50V	D040100087070S		
C751J	00D 963 0234 205	C,ELECT 10UF-M/50V	D040100087070S		
C751K	00D 963 0234 205	C,ELECT 10UF-M/50V	D040100087070S		
C751L	00D 963 0234 205	C,ELECT 10UF-M/50V	D040100087070S		
C751M	00D 963 0234 205	C,ELECT 10UF-M/50V	D040100087070S		
C751N	00D 963 0234 205	C,ELECT 10UF-M/50V	D040100087070S		
C751P	00D 963 0234 205	C,ELECT 10UF-M/50V	D040100087070S		
C751Q	00D 963 0234 205	C,ELECT 10UF-M/50V	D040100087070S		
C751R	00D 963 0234 205	C,ELECT 10UF-M/50V	D040100087070S		
C751S	00D 963 0234 205	C,ELECT 10UF-M/50V	D040100087070S		
C751T	00D 963 0234 205	C,ELECT 10UF-M/50V	D040100087070S		
C751U	00D 963 0234 205	C,ELECT 10UF-M/50V	D040100087070S		
C751V	00D 963 0234 205	C,ELECT 10UF-M/50V	D040100087070S		
C752	00D 963 0234 205	C,ELECT 10UF-M/50V	D040100087070S		
C752A	nsp	C,CERAMIC 0.047UF-Z/50V	D011473597160S		
C752B	nsp	C,CERAMIC 0.047UF-Z/50V	D011473597160S		
C752C	nsp	C,CERAMIC 0.047UF-Z/50V	D011473597160S		
C752D	nsp	C,CERAMIC 0.047UF-Z/50V	D011473597160S		
C752E	nsp	C,CERAMIC 0.047UF-Z/50V	D011473597160S		
C752F	nsp	C,CERAMIC 0.047UF-Z/50V	D011473597160S		
C752G	nsp	C,CERAMIC 0.047UF-Z/50V	D011473597160S		
C752H	nsp	C,CERAMIC 0.047UF-Z/50V	D011473597160S		
C752J	nsp	C,CERAMIC 0.047UF-Z/50V	D011473597160S		
C752K	nsp	C,CERAMIC 0.047UF-Z/50V	D011473597160S		
C752L	nsp	C,CERAMIC 0.047UF-Z/50V	D011473597160S		
C752M	nsp	C,CERAMIC 0.047UF-Z/50V	D011473597160S		
C752N	nsp	C,CERAMIC 0.047UF-Z/50V	D011473597160S		
C752P	nsp	C,CERAMIC 0.047UF-Z/50V	D011473597160S		
C752Q	nsp	C,CERAMIC 0.047UF-Z/50V	D011473597160S		
C752R	nsp	C,CERAMIC 0.047UF-Z/50V	D011473597160S		
C752S	nsp	C,CERAMIC 0.047UF-Z/50V	D011473597160S		
C752T	nsp	C,CERAMIC 0.047UF-Z/50V	D011473597160S		
C752U	nsp	C,CERAMIC 0.047UF-Z/50V	D011473597160S		
C752V	nsp	C,CERAMIC 0.047UF-Z/50V	D011473597160S		
C752W	nsp	C,CERAMIC 0.1UF-Z/50V	D011104597160S		
C752X	nsp	C,CERAMIC 0.1UF-Z/50V	D011104597160S		
C753-771	00D 963 0234 205	C,ELECT 10UF-M/50V	D040100087070S		
C772,773	00D 963 0293 806	C,ELECT 100UF-M/10V (Pb Free)	D040101082090S		
C774	nsp	C,FILM 0.15UF-K/63V	D020154078060S		
C775	00D 963 0021 900	C,FILM 0.047UF-J/100V	D02047306C060S		
C776	00D 960 9008 640	C,FILM 0.022UF-J/100V	D02022306C060S		
C777	00D 963 0234 205	C,ELECT 10UF-M/50V	D040100087070S		
C778,779	nsp	C,CERAMIC 100PF-J/50V	D010101167160S		
C780	00D 963 0234 205	C,ELECT 10UF-M/50V	D040100087070S		
C781	00D 960 9008 640	C,FILM 0.022UF-J/100V	D02022306C060S		
C782	00D 963 0021 900	C,FILM 0.047UF-J/100V	D02047306C060S		
C783	nsp	C,FILM 0.15UF-K/63V	D020154078060S		
C784-790	00D 963 0293 806	C,ELECT 100UF-M/10V (Pb Free)	D040101082090S		
C791,792	00D 963 0234 205	C,ELECT 10UF-M/50V	D040100087070S		
C794	00D 963 0293 806	C,ELECT 100UF-M/10V (Pb Free)	D040101082090S		
C795-799	00D 963 0234 205	C,ELECT 10UF-M/50V	D040100087070S		
C800,801	00D 960 9010 832	C,ELECT 10UF-M/16V	D040100083050S		

Ref. No.	Part No.	Part Name	Remarks	Q'ty	New
OTHERS PARTS GROUP					
CLAMP501	nsp	CLAMP WIRE(SOLDER)		4330000120000S	
CN306	nsp	CN,WIRE 480MM/3P		L000481030060S	
CN514	nsp	CN,WIRE 13P		L000181130010S	
CN702	nsp	CN.HOUSING 15P		L120912150010S	
CN703	nsp	CN.WAFER 8P		L101100030810S	
CN704	nsp	CN.WAFER 19P		L101100031910S	
CN706	nsp	CN,WIRE 5P		L000121050080S	
CP704	nsp	CN.WAFER 15P		L101220150000S	
CP705	nsp	CN.WAFER 3P		L101220030000S	
JACK701	00D 963 0132 103	TER,RCA 4PIN		G602405B0400YS	
JACK702	00D 963 0388 203	TER,RCA 4PIN		G602405B5500YS	
JACK703	00D 963 0132 103	TER,RCA 4PIN		G602405B0400YS	
JACK704,705	00D 963 0132 307	TER,RCA 6PIN		G603603B05000S	

POWER P.W.B. UNIT ASS'Y

	Ref. No.	Part No.	Part Name	Remarks	Q'ty	New
SEMICONDUCTORS GROUP						
△	IC501	00D 963 0057 806	IC KIA78R05PI	J126780500370S		
	IC502	00D 960 0195 808	IC ICP-N15	J120001500030S		
	IC515	00D 960 0174 900	IC KIA7815API	J126781500000S		
	IC516	00D 963 0021 502	IC KIA7915PI	J126791500030S		
	IC517	00D 960 0100 301	IC KIA7812API	J126781200040S		
	Q501	00D 960 0196 409	TR 2SC1740SR	J5021740S0010S		
	Q502	00D 963 0121 208	TR KRC107M	J6020107M0010S		
	Q503	00D 960 0196 409	TR 2SC1740SR	J5021740S0010S		
	D501-503	00D 276 0401 905	D,SWITCHING 1SS133T	K000013300520S		
	D504-507	00D 963 0328 409	D,SWITCHING 1N4007	K000400700010S		
	D508,509	00D 276 0401 905	D,SWITCHING 1SS133T	K000013300520S		
	D521,522	00D 276 0401 905	D,SWITCHING 1SS133T	K000013300520S		
	D523-526	00D 963 0328 409	D,SWITCHING 1N4007	K000400700010S		
	ZD501	00D 960 0095 500	D,ZENER MTZJ5.1B	K06005R144520S		
	ZD502	00D 963 0219 903	D,ZENER MTZJ16B	K06016R044520S		
RESISTORS GROUP						
	R507	00D 241 2376 964	R,METAL FILM 47-J,1/4W	C060047063050S		
	R516-519	00D 963 0216 003	R,METAL FILM 0.22-J,1W	C060R22065050S		
	R520	00D 963 0215 907	R,METAL FILM 4.7-J,1W	C0604R7065050S		
CAPACITORS GROUP						
	C501	00D 963 0234 205	C,ELECT 10UF-M/50V	D040100087070S		
	C502	00D 963 0217 002	C,ELECT 3300UF-M/16V	D040332083010S		
	C503	00D 963 0293 602	C,ELECT 1UF-M/50V (Pb Free)	D040010087150S		
	C504	00D 963 0323 802	C,CERAMIC AC(SAFETY) 0.0047UF 250VAC	D00847208H010S		
	C506	00D 963 0293 602	C,ELECT 1UF-M/50V (Pb Free)	D040010087150S		
	C526,527	00D 960 0186 202	C,ELECT 220UF-M/35V	D040221085050S		
	C528	00D 963 0324 908	C,ELECT 4700UF-M/35V	D040472085020S		
	C529	00D 963 0224 707	C,ELECT 2200UF-M/35V	D040222085020S		
	C530-532	00D 963 0021 900	C,FILM 0.047UF-J/100V	D02047306C060S		
	C534,535	00D 963 0234 205	C,ELECT 10UF-M/50V	D040100087070S		
OTHERS PARTS GROUP						
	BKT501,502	nsp	SHIELD PLATE GND	3070045526010S		
	CLAMP102-105	nsp	CLAMP WIRE(SOLDER)	4330000120000S		
	CN505	nsp	CN.WAFER 7P	L101100030710S		
	CN506	nsp	CN.WAFER 12P	L101100031210S		
	CP501	nsp	CN.WAFER 2CKT,YEL	L108353280290S		
	CP503	nsp	CN.WAFER 2CKT,RED	L108353280280S		
	CP504	nsp	CN.WAFER ST2P	L108202000220S		
	CP505	nsp	CN.WAFER 7P	L101100040710S		
	CP506	nsp	CN.WAFER 12P	L101100041210S		
	CP511	nsp	CN.WAFER 9P	L101220090000S		
	CP513	nsp	CN.WAFER 3P ANGLE	L102526803010S		

	Ref. No.	Part No.	Part Name	Remarks	Q'ty	New
	CP514		CN.WAFER 13P	L101220130000S		
⚠	F501	00D 963 0236 106	FUSE T8A /250V	N751228001110S		
	F501A	nsp	HOLDER,FUSE CLIP	G645000050010S		
	F501B	nsp	HOLDER,FUSE CLIP	G645000050010S		
⚠	F503	00D 963 0236 106	FUSE T8A /250V	N751228001110S		
	F503A	nsp	HOLDER,FUSE CLIP	G645000050010S		
	F503B	nsp	HOLDER,FUSE CLIP	G645000050010S		
	GND501	nsp	TERMINAL EARTH	3790040886000S		
	RLY501	00D 963 0218 205	RELAY HL3-1A-9SH DC9V 1A	G680090102020S		
⚠	SUB501	00D 963 0387 602	SUB TRANS	8200280150401S		
		nsp	HEAT SINK	2120043538050S		
		nsp	HEAT SINK	2120044298010S		
		nsp	SCREW,TAP TITE +2S 3*8 B-TYPE ZNW/BH	B020030081B10S		
		00D 963 0328 409	D,SWITCHING 1N4007	K000400700010S		
⚠		00D 963 0236 407	SOCKET,POWER RECEPTA 2P	G435204004011S		

2CH-AMP P.W.B. UNIT ASS'Y

Ref. No.	Part No.	Part Name	Remarks	Q'ty	New
SEMICONDUCTORS GROUP					
IC401D	00D 960 0159 501	IC KIA7805API	J126780500110S		
IC401H	00D 963 0388 805	CN,WIRE 110MM/3P	L000111030040S		
IC402D	00D 963 0226 608	IC KIA78R33PI	J12678R330010S		
IC402X	00D 963 0366 603	IC KIA1117PI50	J126111750050S		
IC403D	00D 963 0366 706	IC KIA1117PI00	J126111700050S		
Q401SBL	00D 996 0018 706	TR 2SD2390-Y	J5032390Y0000S		
Q401SBR	00D 996 0018 706	TR 2SD2390-Y	J5032390Y0000S		
Q402D	00D 960 0097 304	TR KRC102M	J6020102M0010S		
Q402SBL	00D 996 0018 706	TR 2SD2390-Y	J5011560Y0000S		
Q402SBR	00D 996 0018 706	TR 2SD2390-Y	J5011560Y0000S		
Q403SBL	00D 963 0280 107	TR 2SC3964	J502396400000S		
Q403SBR	00D 963 0280 107	TR 2SC3964	J502396400000S		
Q404SBL	00D 960 0196 506	TR KSC1845F	J5021845F0000S		
Q404SBR	00D 960 0196 506	TR KSC1845F	J5021845F0000S		
Q405SBL	00D 273 0459 903	TR KTC2874B	J502287400010S		
Q405SBR	00D 273 0459 903	TR KTC2874B	J502287400010S		
Q406SBL	00D 960 0196 205	TR KSA992F	J5000992F0050S		
Q406SBR	00D 960 0196 205	TR KSA992F	J5000992F0050S		
Q407SBL	00D 960 0196 205	TR KSA992F	J5000992F0050S		
Q407SBR	00D 960 0196 205	TR KSA992F	J5000992F0050S		
Q408SBL	00D 960 0196 506	TR KSC1845F	J5021845F0000S		
Q408SBR	00D 960 0196 506	TR KSC1845F	J5021845F0000S		
Q409D	00D 960 0097 304	TR KRC102M	J6020102M0010S		
D401H	00D 963 0328 409	D,SWITCHING 1N4007	K000400700010S		
D401SBL	00D 963 0341 004	D,SWITCHING KDS4148U	K005041480030S		
D401SBR	00D 963 0341 004	D,SWITCHING KDS4148U	K005041480030S		
D401X	00D 963 0328 409	D,SWITCHING 1N4007	K000400700010S		
D402	00D 276 0401 905	D,SWITCHING 1SS133T	K000013300520S		
D402H	00D 963 0328 409	D,SWITCHING 1N4007	K000400700010S		
D402SBL	00D 963 0341 004	D,SWITCHING KDS4148U	K005041480030S		
D402SBR	00D 963 0341 004	D,SWITCHING KDS4148U	K005041480030S		
D402X	00D 963 0328 409	D,SWITCHING 1N4007	K000400700010S		
D403	00D 276 0401 905	D,SWITCHING 1SS133T	K000013300520S		
ZD401D	00D 960 0095 607	D,ZENER MTZJ5.6B	K06005R644520S		
ZD401SBL	00D 963 0367 008	D,ZENER 0.2W 3.3V UDZ S	K06603R34P400S		
ZD401SBR	00D 963 0367 008	D,ZENER 0.2W 3.3V UDZ S	K06603R34P400S		
ZD402SBL	00D 963 0367 008	D,ZENER 0.2W 3.0V UDZ S	K06603R04P400S		
ZD402SBR	00D 963 0367 008	D,ZENER 0.2W 3.0V UDZ S	K06603R04P400S		
RESISTORS GROUP					
R401D	00D 963 9006 269	R,FIXED 1WJ-0.22	N113135622820S		
R401H	00D 963 9006 269	R,FIXED 1WJ-0.22	N113135622820S		
R401X	00D 963 9006 269	R,FIXED 1WJ-0.22	N113135622820S		
R402D	00D 963 9006 269	R,FIXED 1WJ-0.22	N113135622820S		
R402H	00D 963 9006 269	R,FIXED 1WJ-0.22	N113135622820S		
R402X	00D 963 9006 269	R,FIXED 1WJ-0.22	N113135622820S		
R410SBL	00D 963 9005 642	R,METAL FILM 1.2K-J,1W	C060012265050S		
R410SBR	00D 963 9005 642	R,METAL FILM 1.2K-J,1W	C060012265050S		
R411SBL	00D 960 9010 719	R,METAL FILM 47-J,1W	C060047065060S		
R411SBR	00D 960 9010 719	R,METAL FILM 47-J,1W	C060047065060S		

Ref. No.	Part No.	Part Name	Remarks	Q'ty	New
R414SBL	00D 963 9006 285	R,FIXED 1WJ-5.6K	N113135656220S		
R414SBR	00D 963 9006 285	R,FIXED 1WJ-5.6K	N113135656220S		
R415SBL	00D 963 9006 285	R,FIXED 1WJ-5.6K	N113135656220S		
R415SBR	00D 963 9006 285	R,FIXED 1WJ-5.6K	N113135656220S		
R419SBL	00D 963 0215 907	R,METAL FILM 4.7-J,1W	C0604R7065050S		
R419SBR	00D 963 0215 907	R,METAL FILM 4.7-J,1W	C0604R7065050S		
R420SBL	00D 963 0215 907	R,METAL FILM 4.7-J,1W	C0604R7065050S		
R420SBR	00D 963 0215 907	R,METAL FILM 4.7-J,1W	C0604R7065050S		
R421SBL	00D 963 0345 903	R,FIXED 2WJ-0.47	N113136647820S		
R421SBR	00D 963 0345 903	R,FIXED 2WJ-0.47	N113136647820S		
R422SBL	00D 963 0345 903	R,FIXED 2WJ-0.47	N113136647820S		
R422SBR	00D 963 0345 903	R,FIXED 2WJ-0.47	N113136647820S		
R423SBL	00D 963 0345 903	R,FIXED 2WJ-0.47	N113136647820S		
R423SBR	00D 963 0345 903	R,FIXED 2WJ-0.47	N113136647820S		
R424SBL	00D 963 0345 903	R,FIXED 2WJ-0.47	N113136647820S		
R424SBR	00D 963 0345 903	R,FIXED 2WJ-0.47	N113136647820S		
R429SBL	00D 963 9006 256	R,FIXED 1WJ-10	N113135610020S		
R429SBR	00D 963 9006 256	R,FIXED 1WJ-10	N113135610020S		
R430SBL	00D 963 9006 256	R,FIXED 1WJ-10	N113135610020S		
R430SBR	00D 963 9006 256	R,FIXED 1WJ-10	N113135610020S		
VR401,402	00D 963 0366 407	VR,SEMI CARBON EVN-DCAA03B 1KB	C541102315000S		
CAPACITORS GROUP					
C401D	00D 963 0021 900	C,FILM 0.047UF-J/100V	D02047306C060S		
C401H	00D 963 0021 900	C,FILM 0.047UF-J/100V	D02047306C060S		
C401SBL	00D 963 9006 544	C,ELECT 22UF-M/25V	D040220084050S		
C401SBR	00D 963 9006 544	C,ELECT 22UF-M/25V	D040220084050S		
C401X	nsp	C,CERAMIC 0.1UF-K/50V	D011104577160S		
C402D	00D 963 0021 900	C,FILM 0.047UF-J/100V	D02047306C060S		
C402H	00D 963 0021 900	C,FILM 0.047UF-J/100V	D02047306C060S		
C402SBL	00D 963 0234 205	C,ELECT 10UF-M/50V	D040100087070S		
C402SBR	00D 963 0234 205	C,ELECT 10UF-M/50V	D040100087070S		
C402X	00D 963 9003 097	C,FILM 0.1UF-K/250V	D02010407H080S		
C403D	00D 963 0021 900	C,FILM 0.047UF-J/100V	D02047306C060S		
C403H	00D 963 0021 900	C,FILM 0.047UF-J/100V	D02047306C060S		
C403SBL	00D 963 0367 101	C,CERAMIC 220PF-J/500V	D00422106D05CS		
C403SBR	00D 963 0367 101	C,CERAMIC 220PF-J/500V	D00422106D05CS		
C404D	00D 960 0133 404	C,ELECT 1000UF 16V	D040103083020S		
C404H	00D 963 0217 002	C,ELECT 330UF-M/16V	D040332083010S		
C404SBL	00D 963 0338 208	C,CERAMIC 470PF-K/500V	D00447127D050S		
C404SBR	00D 963 0338 208	C,CERAMIC 470PF-K/500V	D00447127D050S		
C404X	00D 963 0276 409	C,ELECT 100UF-M/16V	D040101083090S		
C405D	00D 963 0338 402	C,ELECT 330UF-M/6.3V	D040331081050S		
C405SBL	00D 963 0216 100	C,CERAMIC 33PF-J/500V	D00033006D050S		
C405SBR	00D 963 0216 100	C,CERAMIC 33PF-J/500V	D00033006D050S		
C406D	nsp	C,CERAMIC 0.1UF-K/50V	D011104577160S		
C406SBL	00D 963 0293 709	C,ELECT 100UF-M/10V	D040101082070S		
C406SBR	00D 963 0293 709	C,ELECT 100UF-M/10V	D040101082070S		
C406X	nsp	C,CERAMIC 1000PF-K/50V	D011102777160S		
C407D	nsp	C,CERAMIC 1000PF-K/50V	D011102777160S		
C407SBL	00D 963 9003 194	C,FILM 0.0022UF-J/100V	D02022206C060S		
C407SBR	00D 963 9003 194	C,FILM 0.0022UF-J/100V	D02022206C060S		
C407X	00D 963 0293 709	C,ELECT 100UF-M/10V	D040101082070S		
C408D	00D 963 0338 402	C,ELECT 330UF-M/6.3V	D040331081050S		

Ref. No.	Part No.	Part Name	Remarks	Q'ty	New
C408SBL	00D 963 0234 506	C,ELECT 47UF-M/50V (Pb Free)	D040470087070S		
C408SBR	00D 963 0234 506	C,ELECT 47UF-M/50V (Pb Free)	D040470087070S		
C409D	nsp	C,CERAMIC 0.1UF-K/50V	D011104577160S		
C409SBL	00D 963 9003 084	C,CERAMIC 100PF-K/500V	D00410106D050S		
C409SBR	00D 963 9003 084	C,CERAMIC 100PF-K/500V	D00410106D050S		
C410D	00D 963 0338 402	C,ELECT 330UF-M/6.3V	D040331081050S		
C410SBL	00D 963 0234 205	C,ELECT 10UF-M/50V	D040100087070S		
C410SBR	00D 963 0234 205	C,ELECT 10UF-M/50V	D040100087070S		
C411D	nsp	C,CERAMIC 0.1UF-K/50V	D011104577160S		
C411SBL	00D 963 9003 084	C,CERAMIC 100PF-K/500V	D00410106D050S		
C411SBR	00D 963 9003 084	C,CERAMIC 100PF-K/500V	D00410106D050S		
C412D	nsp	C,CERAMIC 0.1UF-K/50V	D011104577160S		
C412SBL	nsp	C,CERAMIC 0.022UF-K/25V	D011223777160S		
C412SBR	nsp	C,CERAMIC 0.022UF-K/25V	D011223777160S		
C413D	00D 963 0024 907	C,ELECT 1000UF-M/6.3V	D040102081060S		
C413SBL	00D 963 9003 097	C,FILM 0.1UF-K/250V	D02010407H080S		
C413SBR	00D 963 9003 097	C,FILM 0.1UF-K/250V	D02010407H080S		
C443	nsp	C,CERAMIC 1000PF-K/50V	D011102777160S		
OTHERS PARTS GROUP					
CLAMP401	nsp	CLAMP WIRE(SOLDER)	4330000120000S		
CN203	nsp	CN,WIRE 160MM/3P	L000161030060S		
CN401A	nsp	CN,WIRE 5P	L000191050030S		
CN405	nsp	CN,WIRE 5P	L000321050020S		
CN705	nsp	CN,WIRE 150MM/3P	L000151030010S		
CN904	nsp	CN,WIRE 6P	L000141060030S		
CP102	nsp	CN.WAFER 2.5MM 5267-03A 3P	L102526700300S		
CP201	nsp	CN.WAFER 10P	L101220100000S		
CP402	nsp	CN.WAFER 3P	L102526700300S		
L401SBL	nsp	COIL INDUCTOR 0.5UH	D330R50000000S		
L401SBR	nsp	COIL INDUCTOR 0.5UH	D330R50000000S		
TP401,402	nsp	CN.WAFER 3P ANGLE	L101530150310S		
	00D 963 0328 409	D,SWITCHING 1N4007	K000400700010S		

CPU P.W.B. UNIT ASS'Y

Ref. No.	Part No.	Part Name	Remarks	Q'ty	New
SEMICONDUCTORS GROUP					
IC712-715	00D 963 0024 004	IC NJM2068M			
IC804	963243000020D	IC,CPU MICRO PROCESS	M30626FHPFP		
IC806	00D 960 0100 301	IC KIA7812API			
IC813	00D 963 0367 204	IC SN74HC151PWR			
IC817	00D 963 0244 907	IC SN74LV14APWR			
IC818	00D 963 0367 307	IC SN74AHCU04PWR			
IC824	00D 963 0043 807	IC BA4510F-E2/SOP8			
IC827	00D 963 0043 807	IC BA4510F-E2/SOP8			
IC830	00D 262 2813 903	SN74AHCT08PW-EL2 +C			
Q704C	00D 963 0044 301	TR KTC2875B(MB)	<div style="border: 1px solid black; border-radius: 10px; padding: 5px;"> ファームウェアをアップデート するときは、SDIで最終バージョン を確認して下さい。 サービス基板はアップデートし て使用下さい。 When update Firmware, please confirm a last version in SDI. Use the service board after updating it. </div>		
Q704FL	00D 963 0044 301	TR KTC2875B(MB)			
Q704FR	00D 963 0044 301	TR KTC2875B(MB)			
Q704SBL	00D 963 0044 301	TR KTC2875B(MB)			
Q704SBR	00D 963 0044 301	TR KTC2875B(MB)			
Q704SL	00D 963 0044 301	TR KTC2875B(MB)			
Q704SR	00D 963 0044 301	TR KTC2875B(MB)			
Q704SW	00D 963 0044 301	TR KTC2875B(MB)			
Q801	00D 963 0120 704	TR KRA102S			
Q802-805	00D 963 0044 301	TR KTC2875B(MB)			
Q806	00D 963 0121 509	TR KTC3875S			
Q807	00D 960 0285 006	TR KRC104S			
Q810D	00D 963 0245 100	D,SWITCHING KDS226ST1(C3)			
Q811D	00D 963 0245 100	D,SWITCHING KDS226ST1(C3)			
Q812D	00D 963 0120 801	TR KRC102S			
Q813D	00D 963 0120 704	TR KRA102S			
D801-804	00D 963 0355 401	D,SWITCHING KDS4148U			
D805	00D 963 0328 409	D,SWITCHING 1N4007			
D807	00D 963 0355 401	D,SWITCHING KDS4148U			
D807D	00D 963 0355 401	D,SWITCHING KDS4148U			
D808D	00D 963 0341 305	D,ESD IMSA-6802-01A			
D809D	00D 963 0355 401	D,SWITCHING KDS4148U			
D810D	00D 963 0341 305	D,ESD IMSA-6802-01A			
D811D	00D 963 0341 305	D,ESD IMSA-6802-01A			
ZD801	00D 963 0047 502	D,ZENER MTZJ3.3B			
RESISTORS GROUP					
R857	00D 960 9003 807	R,METAL FILM 100-J,1/4W			
CAPACITORS GROUP					
C751C	00D 963 0234 205	C,ELECT 10UF-M/50V			
C751FL	00D 963 0234 205	C,ELECT 10UF-M/50V			
C751FR	00D 963 0234 205	C,ELECT 10UF-M/50V			
C751SBL	00D 963 0234 205	C,ELECT 10UF-M/50V			
C751SBR	00D 963 0234 205	C,ELECT 10UF-M/50V			
C751SL	00D 963 0234 205	C,ELECT 10UF-M/50V			
C751SR	00D 963 0234 205	C,ELECT 10UF-M/50V			
C751SW	00D 963 0234 205	C,ELECT 10UF-M/50V			
C752C	00D 963 0350 503	C,CERAMIC 390PF-J/50V			
C752FL	00D 963 0223 708	C,CERAMIC 270PF-J/50V			

Ref. No.	Part No.	Part Name	Remarks	Q'ty	New
C752FR	00D 963 0223 708	C,CERAMIC 270PF-J/50V	D010271167160S		
C752SBL	00D 960 9009 814	C,CERAMIC 330PF-J/50V	D010331167160S		
C752SBR	00D 960 9009 814	C,CERAMIC 330PF-J/50V	D010331167160S		
C752SL	00D 960 9009 814	C,CERAMIC 330PF-J/50V	D010331167160S		
C752SR	00D 960 9009 814	C,CERAMIC 330PF-J/50V	D010331167160S		
C752SW	00D 963 0350 503	C,CERAMIC 390PF-J/50V	D010391167160S		
C753C	00D 963 0224 008	C,CERAMIC 470PF-J/50V	D010471167160S		
C753FL	00D 963 0223 902	C,CERAMIC 39PF-J/50V	D010390167160S		
C753FR	00D 963 0223 902	C,CERAMIC 39PF-J/50V	D010390167160S		
C753SBL	00D 963 0223 708	C,CERAMIC 270PF-J/50V	D010271167160S		
C753SBR	00D 963 0223 708	C,CERAMIC 270PF-J/50V	D010271167160S		
C753SL	00D 963 0223 708	C,CERAMIC 270PF-J/50V	D010271167160S		
C753SR	00D 963 0223 708	C,CERAMIC 270PF-J/50V	D010271167160S		
C753SW	00D 963 0224 008	C,CERAMIC 470PF-J/50V	D010471167160S		
C755C	nsp	C,CERAMIC 0.1UF-Z/50V	D011104597160S		
C755FL	nsp	C,CERAMIC 0.1UF-Z/50V	D011104597160S		
C755FR	nsp	C,CERAMIC 0.1UF-Z/50V	D011104597160S		
C755SBL	nsp	C,CERAMIC 0.1UF-Z/50V	D011104597160S		
C755SBR	nsp	C,CERAMIC 0.1UF-Z/50V	D011104597160S		
C755SL	nsp	C,CERAMIC 0.1UF-Z/50V	D011104597160S		
C755SR	nsp	C,CERAMIC 0.1UF-Z/50V	D011104597160S		
C755SW	nsp	C,CERAMIC 0.1UF-Z/50V	D011104597160S		
C756C	00D 963 9003 194	C,FILM 0.0022UF-J/100V	D02022206C060S		
C756FL	00D 963 9003 194	C,FILM 0.0022UF-J/100V	D02022206C060S		
C756FR	00D 963 9003 194	C,FILM 0.0022UF-J/100V	D02022206C060S		
C756SBL	00D 963 9003 194	C,FILM 0.0022UF-J/100V	D02022206C060S		
C756SBR	00D 963 9003 194	C,FILM 0.0022UF-J/100V	D02022206C060S		
C756SL	00D 963 9003 194	C,FILM 0.0022UF-J/100V	D02022206C060S		
C756SR	00D 963 9003 194	C,FILM 0.0022UF-J/100V	D02022206C060S		
C756SW	00D 963 9003 194	C,FILM 0.0022UF-J/100V	D02022206C060S		
C757C	nsp	C,CERAMIC 10UF-Z/10V	D011106592200S		
C757FL	nsp	C,CERAMIC 10UF-Z/10V	D011106592200S		
C757FR	nsp	C,CERAMIC 10UF-Z/10V	D011106592200S		
C757SBL	nsp	C,CERAMIC 10UF-Z/10V	D011106592200S		
C757SBR	nsp	C,CERAMIC 10UF-Z/10V	D011106592200S		
C757SL	nsp	C,CERAMIC 10UF-Z/10V	D011106592200S		
C757SR	nsp	C,CERAMIC 10UF-Z/10V	D011106592200S		
C757SW	nsp	C,CERAMIC 10UF-Z/10V	D011106592200S		
C803	nsp	C,CERAMIC 100PF-J/50V	D010101167160S		
C804,805	nsp	C,CERAMIC 0.1UF-Z/50V	D011104597160S		
C806	nsp	C,CERAMIC 0.01UF-K/50V	D011103777160S		
C807,808	nsp	C,CERAMIC 0.022UF-Z/50V	D011223597160S		
C809	00D 963 0293 709	C,ELECT 100UF-M/10V	D040101082070S		
C810	nsp	C,CERAMIC 0.1UF-Z/50V	D011104597160S		
C813	nsp	C,CERAMIC 0.1UF-Z/50V	D011104597160S		
C814-816	nsp	C,CERAMIC 0.01UF-K/50V	D011103777160S		
C818	00D 960 9010 010	C,ELECT 4.7UF-M/50V	D0404R7087250S		
C819	nsp	C,CERAMIC 0.01UF-K/50V	D011103777160S		
C824,825	00D 963 0234 205	C,ELECT 10UF-M/50V	D040100087070S		
C826-831	nsp	C,CERAMIC 100PF-J/50V	D010101167160S		
C836,837	nsp	C,CERAMIC 0.022UF-Z/50V	D011223597160S		
C865L	nsp	C,CERAMIC 120PF-J/50V	D010121167160S		
C865R	nsp	C,CERAMIC 120PF-J/50V	D010121167160S		
C871L	00D 963 0216 304	C,FILM 0.001UF-J/100V	D02010206C060S		
C871R	00D 963 0216 304	C,FILM 0.001UF-J/100V	D02010206C060S		
C916D	nsp	C,CERAMIC 0.1UF-Z/50V	D011104597160S		

Ref. No.	Part No.	Part Name	Remarks	Q'ty	New
C917D	nsp	C,CERAMIC 0.1UF-Z/50V	D011104597160S		
C918D	nsp	C,CERAMIC 0.1UF-Z/50V	D011104597160S		
C921D	nsp	C,CERAMIC 100PF-J/50V	D010101167160S		
C923D	nsp	C,CERAMIC 22PF-J/50V	D010220167160S		
C924D	nsp	C,CERAMIC 22PF-J/50V	D010220167160S		
C927D	00D 963 9005 862	C,ELECT 47UF-M/16V	D040470083080S		
C928D	00D 963 9005 862	C,ELECT 47UF-M/16V	D040470083080S		
C931D	nsp	C,CERAMIC 100PF-J/50V	D010101167160S		
C932D	nsp	C,CERAMIC 0.01UF-K/50V	D011103777160S		
C933D	nsp	C,CERAMIC 0.01UF-K/50V	D011103777160S		
C934D	nsp	C,CERAMIC 0.01UF-K/50V	D011103777160S		
C935D	00D 960 9010 010	C,ELECT 4.7UF-M/50V	D0404R7087250S		
C936D	00D 960 9010 010	C,ELECT 4.7UF-M/50V	D0404R7087250S		
C937D	nsp	C,CERAMIC 1000PF-K/50V	D011102777160S		
C938D	00D 960 9010 010	C,ELECT 4.7UF-M/50V	D0404R7087250S		
C939D	nsp	C,CERAMIC 0.01UF-K/50V	D011103777160S		
C940D	nsp	C,CERAMIC 0.01UF-K/50V	D011103777160S		
C941D	00D 963 0244 606	C,ELECT 0.1UF-M/50V (Pb Free)	D040R10087080S		
C950D	nsp	C,CERAMIC 0.1UF-Z/50V	D011104597160S		
C951D	nsp	C,CERAMIC 0.1UF-Z/50V	D011104597160S		
C952D	00D 963 0234 205	C,ELECT 10UF-M/50V	D040100087070S		
C953D	00D 963 0234 205	C,ELECT 10UF-M/50V	D040100087070S		
C954D	nsp	C,CERAMIC 0.1UF-Z/50V	D011104597160S		
C955D	nsp	C,CERAMIC 0.1UF-Z/50V	D011104597160S		
C956D	nsp	C,CERAMIC 22PF-J/50V	D010220167160S		
C957D	nsp	C,CERAMIC 0.1UF-Z/50V	D011104597160S		
C959D	nsp	C,CERAMIC 22PF-J/50V	D010220167160S		
BC801	00D 254 4666 005	CE04W0H105ZC(FG)	D041105090010S		
OTHERS PARTS GROUP					
BD802-809	nsp	COIL,BEAD MB-160808	D340160800060S		
BD809D	nsp	COIL,BEAD MB-160808	D340160800060S		
BD810-817	nsp	COIL,BEAD MB-160808	D340160800060S		
CN106	nsp	CN.WAFER 5P	L101100030510S		
CN108	00D 963 0085 302	CN.WAFER 17P	L101100031710S		
CP01	nsp	CN.WAFER 16P	L101100040910S		
CP301A	00D 963 0367 400	CN.FPC 35P	L131524923520S		
CP701	nsp	CN.WAFER 19P	L101100041910S		
CP702	nsp	CN.WAFER 15P	L100912150010S		
CP703	nsp	CN.WAFER 8P	L101100040810S		
CP801	00D 963 0149 303	CN.FPC 15P	L131111500010S		
CP802	nsp	CN.WAFER 16P	L100912160010S		
CP803	nsp	CN.WAFER 16P	L101100041610S		
CP804	nsp	CN.WAFER 15P	L100912150010S		
CP805	nsp	CN.WAFER 08P	L100912080010S		
CP1001	nsp	CN.WAFER 08P	L101100040810S		
CP1002	nsp	CN.WAFER 9P	L101100040910S		
JACK801	00D 963 0217 905	TER,RCA 2PIN	G601206A0200YS		
JACK802	00D 963 0294 601	JACK,D3.5 EARPHONE	G40100350000YS		
L801D	nsp	COIL INDUCTOR 4.7UH	D3304R7000150S		

Ref. No.	Part No.	Part Name	Remarks	Q'ty	New
L802D	nsp	COIL INDUCTOR 4.7UH	D3304R7000150S		
L803D	nsp	COIL INDUCTOR 4.7UH	D3304R7000150S		
L805D	nsp	COIL INDUCTOR 4.7UH	D3304R7000150S		
L806D	nsp	COIL,FILTER-INDUCTOR 22UH	D330220010520S		
L807D	nsp	COIL,FILTER-INDUCTOR 22UH	D330220010520S		
TP803	nsp	CN.WAFER 8P	L101220080000S		
TP804	nsp	CN.WAFER 4P	L101220040000S		
X801	00D 963 0217 701	RESONATOR,CERAMIC ZTT12.00MT	E830120000060S		
OPT801D	00D 963 0237 503	MODULE JSR1165-C	E100116500040S		
OPT802D	00D 963 0237 503	MODULE JSR1165-C	E100116500040S		
	nsp	CN,WIRE 110MM/1P	L000111010010S		

HDMI P.W.B. UNIT ASS'Y

Ref. No.	Part No.	Part Name	Remarks	Q'ty	New
SEMICONDUCTORS GROUP					
IC01	nsp	SII9185CTU	00D2623721007		
IC03	nsp	IC SE1117-1.8	J126111718010S		
IC12	nsp	IC BU4094BCF-E2	J040140940030S		
IC801	nsp	ADSP21367KSZ1A1136	00D2623709016		
IC802	nsp	W9864G2GH-7	00D2623746008		
IC803	nsp	IC EN29LV160T-70TCP	J005291600010S		
IC807	nsp	LC89057W-VF4A	00D2623449004		
IC808	nsp	ADAU1328BSTZ1136	00D2623645015		
IC809-811	nsp	IC SN74LVC244APWR	J040742440230S		
IC812	nsp	IC SN74HCT244PWR	J040742440220S		
IC814,815	nsp	IC SN74HCT00PWR	J040740000210S		
IC816	nsp	74LVX157MTC +C	00D2622870904		
IC823	nsp	IC KIA7805API	J126780500110S		
IC825,826	nsp	IC SN74LVC74APWR	J040747400200S		
IC832	nsp	IC SE1117-33-PF	J126111733020S		
Q01,02	nsp	TR KRC102S	J522010200210S		
Q03,04	nsp	TR KRC104S	J522104S00210S		
Q05	nsp	TR KRA102S	J520010200210S		
Q06	nsp	TR KTC3875S	J522038750210S		
Q07	nsp	TR KRC104S	J522104S00210S		
Q810D	nsp	TR KRC102S	J522010200210S		
Q811D	nsp	TR KRA102S	J520010200210S		
Q814D	nsp	TR KRA102S	J520010200210S		
D01-36	nsp	D,ESD IMSA-6802-01A	K067680200010S		
D44	nsp	D,SWITCHING KDS4148U	K005041480030S		
CAPACITORS GROUP					
C01	nsp	C,CERAMIC 1000PF-K/50V	D011102777160S		
C02-05	nsp	C,CERAMIC 0.1UF-K/50V	D011104577162S		
C06,07	nsp	C,CERAMIC 1000PF-K/50V	D011102777160S		
C08-14	nsp	C,CERAMIC 0.1UF-K/50V	D011104577162S		
C15-17	nsp	C,CERAMIC 1000PF-K/50V	D011102777160S		
C18,19	nsp	C,CERAMIC 0.1UF-K/50V	D011104577162S		
C20	nsp	C,CERAMIC 1000PF-K/50V	D011102777160S		
C21	nsp	C,CERAMIC 100PF-J/50V	D010101167160S		
C22	nsp	C,CERAMIC 1000PF-K/50V	D011102777160S		
C23	nsp	C,CERAMIC 100PF-J/50V	D010101167160S		
C24,25	nsp	C,ELECT 10UF-MVG/16V	D050100083460S		
C26,27	nsp	C,CERAMIC 0.01UF-K/50V	D011103777160S		
C28H	nsp	C,ELECT 10UF-MVG/16V	D050100083460S		
C29	nsp	C,CERAMIC 0.1UF-K/50V	D011104577162S		
C29H	nsp	C,ELECT 10UF-MVG/16V	D050100083460S		
C30	nsp	C,CERAMIC 0.1UF-K/50V	D011104577162S		
C30H	nsp	C,ELECT 10UF-MVG/16V	D050100083460S		
C31,32	nsp	C,CERAMIC 0.1UF-K/50V	D011104577162S		
C63-65	nsp	C,CERAMIC 100PF-J/50V	D010101167160S		
C66	nsp	C,CERAMIC 0.01UF-K/50V	D011103777160S		
C831D	nsp	C,CERAMIC 0.1UF-K/50V	D011104577162S		
C832D	nsp	C,CERAMIC 1000PF-K/50V	D011102177101S		
C833D	nsp	C,CERAMIC 100PF-J/50V	D011101167101S		
C834D	nsp	C,CERAMIC 100PF-J/50V	D011101167101S		

Ref. No.	Part No.	Part Name	Remarks	Q'ty	New
C835D	nsp	C,CERAMIC 0.01UF-K/50V	D011103177101S		
C836D	nsp	C,CERAMIC 0.01UF-K/50V	D011103177101S		
C837D	nsp	C,CERAMIC 100PF-J/50V	D011101167101S		
C838D	nsp	C,CERAMIC 100PF-J/50V	D011101167101S		
C839D	nsp	C,CERAMIC 100PF-J/50V	D011101167101S		
C840D	nsp	C,CERAMIC 100PF-J/50V	D011101167101S		
C841D	nsp	C,CERAMIC 100PF-J/50V	D011101167101S		
C842D	nsp	C,CERAMIC 100PF-J/50V	D011101167101S		
C843D	nsp	C,CERAMIC 100PF-J/50V	D011101167101S		
C844D	nsp	C,CERAMIC 100PF-J/50V	D011101167101S		
C845D	nsp	C,CERAMIC 0.1UF-K/50V	D011104177101S		
C846D	nsp	C,CERAMIC 1000PF-K/50V	D011102177101S		
C847D	nsp	C,CERAMIC 1000PF-K/50V	D011102177101S		
C848D	nsp	C,CERAMIC 1000PF-K/50V	D011102177101S		
C849D	nsp	C,CERAMIC 1000PF-K/50V	D011102177101S		
C850D	nsp	C,CERAMIC 1000PF-K/50V	D011102177101S		
C851D	nsp	C,CERAMIC 1000PF-K/50V	D011102177101S		
C852D	nsp	C,CERAMIC 1000PF-K/50V	D011102177101S		
C853D	nsp	C,CERAMIC 1000PF-K/50V	D011102177101S		
C854D	nsp	C,CERAMIC 0.1UF-K/50V	D011104177101S		
C855D	nsp	C,CERAMIC 0.1UF-K/50V	D011104177101S		
C856D	nsp	C,CERAMIC 0.1UF-K/50V	D011104177101S		
C857D	nsp	C,CERAMIC 0.1UF-K/50V	D011104177101S		
C858D	nsp	C,CERAMIC 0.1UF-K/50V	D011104177101S		
C859D	nsp	C,CERAMIC 0.1UF-K/50V	D011104177101S		
C860D	nsp	C,CERAMIC 0.1UF-K/50V	D011104177101S		
C861D	nsp	C,CERAMIC 0.1UF-K/50V	D011104177101S		
C862D	nsp	C,CERAMIC 0.01UF-K/50V	D011103177101S		
C863D	nsp	C,CERAMIC 100PF-J/50V	D011101167101S		
C864D	nsp	C,CERAMIC 4.7UF-K/10V	D011475572200S		
C865D	nsp	C,CERAMIC 5PF-C/50V	D010050107160S		
C866D	nsp	C,CERAMIC 5PF-C/50V	D010050107160S		
C871D	nsp	C,CERAMIC 0.01UF-K/50V	D011103177101S		
C873D	nsp	C,CERAMIC 0.01UF-K/50V	D011103177101S		
C875D	nsp	C,CERAMIC 4.7UF-K/10V	D011475572200S		
C876D	nsp	C,CERAMIC 0.01UF-K/50V	D011103177101S		
C877D	nsp	C,CERAMIC 0.1UF-K/50V	D011104177101S		
C878D	nsp	C,CERAMIC 0.1UF-K/50V	D011104177101S		
C879D	nsp	C,CERAMIC 0.1UF-K/50V	D011104177101S		
C880D	nsp	C,CERAMIC 0.01UF-K/50V	D011103177101S		
C881D	nsp	C,CERAMIC 0.01UF-K/50V	D011103177101S		
C882D	nsp	C,CERAMIC 6PF-D/50V	D010060117160S		
C883D	nsp	C,CERAMIC 6PF-D/50V	D010060117160S		
C884D	nsp	C,CERAMIC 0.1UF-K/50V	D011104577162S		
C885D	nsp	C,CERAMIC 0.022UF-Z/50V	D011223597160S		
C886D	nsp	C,CERAMIC 0.1UF-K/50V	D011104177101S		
C887D	nsp	C,FILM 0.12UF-J/63V	D020124078060S		
C888D	nsp	C,CERAMIC 0.01UF-K/50V	D011103177101S		
C889D	nsp	C,CERAMIC 100PF-J/50V	D011101167101S		
C890D	nsp	C,CERAMIC 0.01UF-K/50V	D011103177101S		
C891D	nsp	C,CERAMIC 0.01UF-K/50V	D011103177101S		
C892D	nsp	C,CERAMIC 4.7UF-K/10V	D011475572200S		
C893D	nsp	C,CERAMIC 0.1UF-K/50V	D011104177101S		
C895D	nsp	C,CERAMIC 0.1UF-K/50V	D011104177101S		
C896D	nsp	C,CERAMIC 0.01UF-K/50V	D011103177101S		
C897D	nsp	C,CERAMIC 0.1UF-K/50V	D011104177101S		

Ref. No.	Part No.	Part Name	Remarks	Q'ty	New
C898D	nsp	C,CERAMIC 0.1UF-K/50V	D011104177101S		
C899D	nsp	C,CERAMIC 100PF-J/50V	D011101167101S		
C900D	nsp	C,CERAMIC 4.7UF-K/10V	D011475572200S		
C901D	nsp	C,ELECT 100UF-MVG/6.3V	D050101081650S		
C902D	nsp	C,CERAMIC 0.1UF-K/50V	D011104177101S		
C903D	nsp	C,CERAMIC 0.1UF-K/50V	D011104177101S		
C904D	nsp	C,CERAMIC 5600PF-K/50V	D011562777160S		
C905D	nsp	C,CERAMIC 390PF-J/50V	D010391167160S		
C906D	nsp	C,CERAMIC 0.1UF-K/50V	D011104177101S		
C907D	nsp	C,CERAMIC 0.1UF-K/50V	D011104177101S		
C908D	nsp	C,ELECT 47UF-MVG/6.3V	D050470081460S		
C909D	nsp	C,CERAMIC 0.1UF-K/50V	D011104177101S		
C910D	nsp	C,ELECT 10UF-MVG/16V	D050100083460S		
C911D	nsp	C,CERAMIC 0.01UF-K/50V	D011103177101S		
C913D	nsp	C,ELECT 10UF-MVG/16V	D050100083460S		
C914D	nsp	C,CERAMIC 0.01UF-K/50V	D011103177101S		
C915D	nsp	C,ELECT 10UF-MVG/16V	D050100083460S		
OTHERS PARTS GROUP					
BD801	nsp	COIL,BEAD MB-160808	D340160800060S		
BD807D	nsp	COIL,BEAD MB-160808	D340160800060S		
BD808D-03	nsp	COIL,BEAD MB-160808	D340160800060S		
CB06	nsp	COIL,BEAD MB-160808	D340160800060S		
CN01	nsp	CN.WAFER 16P	L101100030910S		
CN802	nsp	CN.HOUSING 16P	L120912160010S		
CN803	nsp	CN.WAFER 16P	L101100031610S		
CN804	nsp	CN.HOUSING 15P	L120912150010S		
CN805	nsp	CN.HOUSING 08P	L120912080010S		
CP404	nsp	CN.WAFER 4P	L101220040000S		
CP405	nsp	CN.WAFER 5P	L101220050000S		
CP904	nsp	CN.WAFER 6P	L101220060010S		
J806	nsp	R,CHIP THICK 0-J,1/16W	C20000006M101S		
JACK01-03	00D 963 0388 504	19PIN HDMI CONNECTOR	L109100190020S		
TP801	nsp	CN.WAFER 13P	L101530141310S		
X803D	nsp	FCX-03(16.660MHz)	00D3991091905		
X804D	nsp	FCX-03(24.576MHz)	00D3991053901		

VIDEO P.W.B. UNIT ASS'Y

Ref. No.	Part No.	Part Name	Remarks	Q'ty	New
SEMICONDUCTORS GROUP					
IC1301	00D 960 0175 200	IC BA7625	J171762500000S		
IC1302,1303	00D 963 0083 304	IC BA7626	J171762600000S		
IC1304	00D 960 0239 104	IC KIA7806API	J126780600130S		
IC1305-1307	00D 963 0148 401	IC LA7956	J171795600010S		
Q1301-1303	00D 960 0005 105	TR KTA1266Y	J5001266Y0050S		
Q1304,1305	00D 960 0005 202	TR KTC3198Y	J5023198Y0000S		
Q1306-1309	00D 963 0121 208	TR KRC107M	J6020107M0010S		
Q1310-1313	00D 960 0005 202	TR KTC3198Y	J5023198Y0000S		
Q1314-1317	00D 963 0121 208	TR KRC107M	J6020107M0010S		
D1301	00D 963 0355 401	D,SWITCHING KDS4148U	K005041480030S		
D1302-1305	00D 276 0401 905	D,SWITCHING 1SS133T	K000013300520S		
D1306,1307	00D 963 0355 401	D,SWITCHING KDS4148U	K005041480030S		
CAPACITORS GROUP					
C1301-1309	00D 960 9010 010	C,ELECT 4.7UF-M/50V	D0404R7087250S		
C1310	00D 963 9005 969	C,ELECT 4700UF-M/6.3V	D040472081000S		
C1311,1312	00D 960 0298 802	C,ELECT 470UF-M/6.3V	D040471081070S		
C1313-1315	00D 963 0311 607	C,ELECT 100UF-M/10V (Pb Free)	D040101082090S		
C1316-1321	00D 963 0293 602	C,ELECT 1UF-M/50V (Pb Free)	D040010087150S		
C1322	nsp	C,CERAMIC 0.022UF-K/25V	D011223777160S		
C1323	00D 963 0311 607	C,ELECT 100UF-M/10V (Pb Free)	D040101082090S		
C1324	nsp	C,CERAMIC 0.022UF-K/25V	D011223777160S		
C1326	nsp	C,CERAMIC 0.022UF-K/25V	D011223777160S		
C1328	00D 963 0234 205	C,ELECT 10UF-M/50V	D040100087070S		
C1329	00D 963 0234 506	C,ELECT 47UF-M/50V (Pb Free)	D040470087070S		
C1330	00D 963 0234 205	C,ELECT 10UF-M/50V	D040100087070S		
C1331-1339	00D 963 9005 862	C,ELECT 47UF-M/16V	D040470083080S		
C1340-1345	00D 963 9005 901	C,ELECT 470UF-M/10V,6.3*11	D040471082060S		
C1347	nsp	C,CERAMIC 0.047UF-Z/50V	D011473597160S		
C1348	00D 960 9009 924	C,ELECT 100UF-M/16V	D040101083070S		
C1349,1350	nsp	C,CERAMIC 0.047UF-Z/50V	D011473597160S		
C1351,1352	00D 963 0293 602	C,ELECT 1UF-M/50V (Pb Free)	D040010087150S		
OTHERS PARTS GROUP					
CN406	nsp	CN,WIRE 300MM/3P	L000301030060S		
CN1301	nsp	CN.WAFER 5P	L101220050010S		
CN1303	nsp	CN.WAFER 8P	L101100030810S		
CP1302	nsp	CN.WAFER 9P	L101100030910S		
JACK1301	00D 963 0218 001	TER,RCA 2PIN	G60122001000YS		
JACK1302	00D 963 0218 108	TER,RCA 3PIN	G60630401000YS		
JACK1303,1304	00D 963 0367 709	TER,RCA 6PIN	G603610D0032YS		
	nsp	HEAT SINK	2120044338010S		
	nsp	SCREW,TAP TITE +2S 3*8 B-TYPE ZNW/BH	B020030081B10S		

HDMI_PWR P.W.B. UNIT ASS'Y

Ref. No.	Part No.	Part Name	Remarks	Q'ty	New
SEMICONDUCTORS GROUP					
IC401H1	00D9630366500	IC KIA1117PI33		J126111733050S	
CAPACITORS GROUP					
C405H1	00D9630234205	C,ELECT 10UF-M/50V		D040100087070S	
C406H1	00D9630233303	C,CERAMIC 0.01UF-M/16V		D005103773530S	
OTHERS PARTS GROUP					
CN404	nsp	CN,WIRE 300MM/4P		L000301040110S	
CP513	nsp	CN.WAFER 3P ANGLE		L102526803010S	

PARTS LIST OF P.W.B. UNIT



AVR-588 E3 MODEL

* 本表に "nsp" と記載されている部品は供給できません。

* Parts for which "nsp" is indicated on this table cannot be supplied.

* 本表に記載されている部品は、補修用部品のため製品に使用している部品とは一部、形状、寸法などが異なる場合があります。

* The parts listed below are for maintenance only, might differ from the parts used in the unit in appearances or dimensions.

MAIN P.W.B. UNIT ASS'Y

Ref. No.	Part No.	Part Name	Remarks	Q'ty	New
SEMICONDUCTORS GROUP					
	IC110,111	00D 963 0218 807	IC BU4094BCF-E2	J040140940030S	
	Q101	00D 960 0196 302	TR KTA1268BL	J5001268B0050S	
	Q102-104	00D 960 0196 700	TR KTC3200BL	J5023200B0050S	
	Q104C	00D 960 0196 506	TR KSC1845F	J5021845F0000S	
	Q104FL	00D 960 0196 506	TR KSC1845F	J5021845F0000S	
	Q104FR	00D 960 0196 506	TR KSC1845F	J5021845F0000S	
	Q104SL	00D 960 0196 506	TR KSC1845F	J5021845F0000S	
	Q104SR	00D 960 0196 506	TR KSC1845F	J5021845F0000S	
	Q105	00D 960 0196 700	TR KTC3200BL	J5023200B0050S	
	Q105C	00D 960 0196 603	TR KTC2874B	J502287400010S	
	Q105FL	00D 960 0196 603	TR KTC2874B	J502287400010S	
	Q105FR	00D 960 0196 603	TR KTC2874B	J502287400010S	
	Q105SL	00D 960 0196 603	TR KTC2874B	J502287400010S	
	Q105SR	00D 960 0196 603	TR KTC2874B	J502287400010S	
	Q106	00D 960 0196 700	TR KTC3200BL	J5023200B0050S	
	Q106C	00D 960 0196 205	TR KSA992F	J5000992F0050S	
	Q106FL	00D 960 0196 205	TR KSA992F	J5000992F0050S	
	Q106FR	00D 960 0196 205	TR KSA992F	J5000992F0050S	
	Q106SL	00D 960 0196 205	TR KSA992F	J5000992F0050S	
	Q106SR	00D 960 0196 205	TR KSA992F	J5000992F0050S	
	Q107	00D 960 0196 700	TR KTC3200BL	J5023200B0050S	
	Q107C	00D 960 0196 205	TR KSA992F	J5000992F0050S	
	Q107FL	00D 960 0196 205	TR KSA992F	J5000992F0050S	
	Q107FR	00D 960 0196 205	TR KSA992F	J5000992F0050S	
	Q107SL	00D 960 0196 205	TR KSA992F	J5000992F0050S	
	Q107SR	00D 960 0196 205	TR KSA992F	J5000992F0050S	
	Q108	00D 960 0196 700	TR KTC3200BL	J5023200B0050S	
	Q108C	00D 960 0196 506	TR KSC1845F	J5021845F0000S	
	Q108FL	00D 960 0196 506	TR KSC1845F	J5021845F0000S	
	Q108FR	00D 960 0196 506	TR KSC1845F	J5021845F0000S	
	Q108SL	00D 960 0196 506	TR KSC1845F	J5021845F0000S	
	Q108SR	00D 960 0196 506	TR KSC1845F	J5021845F0000S	
	Q109,110	00D 960 0196 700	TR KTC3200BL	J5023200B0050S	
	Q111	00D 960 0196 302	TR KTA1268BL	J5001268B0050S	
	Q130	00D 960 0196 302	TR KTA1268BL	J5001268B0050S	
	Q131,132	00D 963 0219 602	TR KRC106M	J6020106M0010S	
	Q133-137	00D 960 0097 207	TR KRA102M	J6002202M0010S	
	Q141SW	00D 963 0044 301	TR KTC2875B(MB)	J5222875B0010S	
	Q142	00D 960 0196 700	TR KTC3200BL	J5023200B0050S	
	Q142SW	00D 963 0044 301	TR KTC2875B(MB)	J5222875B0010S	
	Q143,144	00D 960 0196 302	TR KTA1268BL	J5001268B0050S	
	Q145	00D 960 0196 700	TR KTC3200BL	J5023200B0050S	
	Q146,147	00D 960 0196 302	TR KTA1268BL	J5001268B0050S	
	Q151	00D 960 0196 302	TR KTA1268BL	J5001268B0050S	
	Q156	00D 960 0097 304	TR KRC102M	J6020102M0010S	
	Q165	00D 960 0196 700	TR KTC3200BL	J5023200B0050S	
	Q166-171	00D 960 0196 302	TR KTA1268BL	J5001268B0050S	

Ref. No.	Part No.	Part Name	Remarks	Q'ty	New
Q541	00D 963 0121 208	TR KRC107M	J6020107M0010S		
D101C	00D 963 0355 401	D,SWITCHING KDS4148U	K005041480030S		
D101FL	00D 963 0355 401	D,SWITCHING KDS4148U	K005041480030S		
D101FR	00D 963 0355 401	D,SWITCHING KDS4148U	K005041480030S		
D101SL	00D 963 0355 401	D,SWITCHING KDS4148U	K005041480030S		
D101SR	00D 963 0355 401	D,SWITCHING KDS4148U	K005041480030S		
D102C	00D 963 0355 401	D,SWITCHING KDS4148U	K005041480030S		
D102FL	00D 963 0355 401	D,SWITCHING KDS4148U	K005041480030S		
D102FR	00D 963 0355 401	D,SWITCHING KDS4148U	K005041480030S		
D102SL	00D 963 0355 401	D,SWITCHING KDS4148U	K005041480030S		
D102SR	00D 963 0355 401	D,SWITCHING KDS4148U	K005041480030S		
D105C	00D 963 0020 309	D,SWITCHING 1SS133T	K000013300520S		
D105FL	00D 963 0020 309	D,SWITCHING 1SS133T	K000013300520S		
D105FR	00D 963 0020 309	D,SWITCHING 1SS133T	K000013300520S		
D105SL	00D 963 0020 309	D,SWITCHING 1SS133T	K000013300520S		
D105SR	00D 963 0020 309	D,SWITCHING 1SS133T	K000013300520S		
D106,107	00D 963 0355 401	D,SWITCHING KDS4148U	K005041480030S		
D114,115	00D 960 0197 107	D,RECTIFIER BRIDGE KBPC604	K047604000020S		
D139	00D 963 0020 309	D,SWITCHING 1SS133T	K000013300520S		
D140,141	00D 963 0328 409	D,SWITCHING 1N4007	K000400700010S		
D142	00D 963 0355 401	D,SWITCHING KDS4148U	K005041480030S		
D143-152	00D 963 0020 309	D,SWITCHING 1SS133T	K000013300520S		
D153	00D 963 0355 401	D,SWITCHING KDS4148U	K005041480030S		
D154-157	00D 963 0020 309	D,SWITCHING 1SS133T	K000013300520S		
D541	00D 963 0355 401	D,SWITCHING KDS4148U	K005041480030S		
ZD101	00D 963 0058 601	D,ZENER MTZJ12B	K06012R044520S		
ZD101C	00D 963 0367 008	D,ZENER 0.2W 3.3V UDZ	K06603R34P400S		
ZD101FL	00D 963 0367 008	D,ZENER 0.2W 3.3V UDZ	K06603R34P400S		
ZD101FR	00D 963 0367 008	D,ZENER 0.2W 3.3V UDZ	K06603R34P400S		
ZD101SL	00D 963 0367 008	D,ZENER 0.2W 3.3V UDZ	K06603R34P400S		
ZD101SR	00D 963 0367 008	D,ZENER 0.2W 3.3V UDZ	K06603R34P400S		
ZD102C	00D 963 0367 008	D,ZENER 0.2W 3.3V UDZ	K06603R04P400S		
ZD102FL	00D 963 0367 008	D,ZENER 0.2W 3.3V UDZ	K06603R04P400S		
ZD102FR	00D 963 0367 008	D,ZENER 0.2W 3.3V UDZ	K06603R04P400S		
ZD102SL	00D 963 0367 008	D,ZENER 0.2W 3.3V UDZ	K06603R04P400S		
ZD102SR	00D 963 0367 008	D,ZENER 0.2W 3.3V UDZ	K06603R04P400S		
ZD105	00D 960 0095 500	D,ZENER MTZJ5.1B	K06005R144520S		
RESISTORS GROUP					
R101	00D 963 0337 801	R,METAL FILM 100-J,2W	C060010166520S		
R103	00D 963 9005 639	R,METAL FILM 100-J,1W	C060010165060S		
R104	00D 963 0215 907	R,METAL FILM 4.7-J,1W	C0604R7065050S		
R104C	00D 963 9006 285	R,FIXED 1WJ-5.6K	N113135656220S		
R104FL	00D 963 9006 285	R,FIXED 1WJ-5.6K	N113135656220S		
R104FR	00D 963 9006 285	R,FIXED 1WJ-5.6K	N113135656220S		
R104SL	00D 963 9006 285	R,FIXED 1WJ-5.6K	N113135656220S		
R104SR	00D 963 9006 285	R,FIXED 1WJ-5.6K	N113135656220S		
R105	00D 963 0232 906	R,METAL FILM 47K-F,1/4W	C060047343530S		
R105C	00D 963 9006 285	R,FIXED 1WJ-5.6K	N113135656220S		
R105FL	00D 963 9006 285	R,FIXED 1WJ-5.6K	N113135656220S		
R105FR	00D 963 9006 285	R,FIXED 1WJ-5.6K	N113135656220S		
R105SL	00D 963 9006 285	R,FIXED 1WJ-5.6K	N113135656220S		
R105SR	00D 963 9006 285	R,FIXED 1WJ-5.6K	N113135656220S		

Ref. No.	Part No.	Part Name	Remarks	Q'ty	New
R106C	00D 963 0215 907	R,METAL FILM 4.7-J,1W	C0604R7065050S		
R106FL	00D 963 0215 907	R,METAL FILM 4.7-J,1W	C0604R7065050S		
R106FR	00D 963 0215 907	R,METAL FILM 4.7-J,1W	C0604R7065050S		
R106SL	00D 963 0215 907	R,METAL FILM 4.7-J,1W	C0604R7065050S		
R106SR	00D 963 0215 907	R,METAL FILM 4.7-J,1W	C0604R7065050S		
R107C	00D 963 0215 907	R,METAL FILM 4.7-J,1W	C0604R7065050S		
R107FL	00D 963 0215 907	R,METAL FILM 4.7-J,1W	C0604R7065050S		
R107FR	00D 963 0215 907	R,METAL FILM 4.7-J,1W	C0604R7065050S		
R107SL	00D 963 0215 907	R,METAL FILM 4.7-J,1W	C0604R7065050S		
R107SR	00D 963 0215 907	R,METAL FILM 4.7-J,1W	C0604R7065050S		
R108C	00D 963 0345 903	R,FIXED 2WJ-0.47	N113136647820S		
R108FL	00D 963 0345 903	R,FIXED 2WJ-0.47	N113136647820S		
R108FR	00D 963 0345 903	R,FIXED 2WJ-0.47	N113136647820S		
R108SL	00D 963 0345 903	R,FIXED 2WJ-0.47	N113136647820S		
R108SR	00D 963 0345 903	R,FIXED 2WJ-0.47	N113136647820S		
R109C	00D 963 0345 903	R,FIXED 2WJ-0.47	N113136647820S		
R109FL	00D 963 0345 903	R,FIXED 2WJ-0.47	N113136647820S		
R109FR	00D 963 0345 903	R,FIXED 2WJ-0.47	N113136647820S		
R109SL	00D 963 0345 903	R,FIXED 2WJ-0.47	N113136647820S		
R109SR	00D 963 0345 903	R,FIXED 2WJ-0.47	N113136647820S		
R110C	00D 963 0345 903	R,FIXED 2WJ-0.47	N113136647820S		
R110FL	00D 963 0345 903	R,FIXED 2WJ-0.47	N113136647820S		
R110FR	00D 963 0345 903	R,FIXED 2WJ-0.47	N113136647820S		
R110SL	00D 963 0345 903	R,FIXED 2WJ-0.47	N113136647820S		
R110SR	00D 963 0345 903	R,FIXED 2WJ-0.47	N113136647820S		
R111C	00D 963 0345 903	R,FIXED 2WJ-0.47	N113136647820S		
R111FL	00D 963 0345 903	R,FIXED 2WJ-0.47	N113136647820S		
R111FR	00D 963 0345 903	R,FIXED 2WJ-0.47	N113136647820S		
R111SL	00D 963 0345 903	R,FIXED 2WJ-0.47	N113136647820S		
R111SR	00D 963 0345 903	R,FIXED 2WJ-0.47	N113136647820S		
R117,118	00D 963 0144 502	R,CEMENT 0.1-J 5W	C141R10069000S		
R118C	00D 963 9006 256	R,FIXED 1WJ-10	N113135610020S		
R118FL	00D 963 9006 256	R,FIXED 1WJ-10	N113135610020S		
R118FR	00D 963 9006 256	R,FIXED 1WJ-10	N113135610020S		
R118SL	00D 963 9006 256	R,FIXED 1WJ-10	N113135610020S		
R118SR	00D 963 9006 256	R,FIXED 1WJ-10	N113135610020S		
R119C	00D 963 9006 256	R,FIXED 1WJ-10	N113135610020S		
R119FL	00D 963 9006 256	R,FIXED 1WJ-10	N113135610020S		
R119FR	00D 963 9006 256	R,FIXED 1WJ-10	N113135610020S		
R119SL	00D 963 9006 256	R,FIXED 1WJ-10	N113135610020S		
R119SR	00D 963 9006 256	R,FIXED 1WJ-10	N113135610020S		
R127C	00D 963 9005 642	R,METAL FILM 1.2K-J,1W	C060012265050S		
R127FL	00D 963 9005 642	R,METAL FILM 1.2K-J,1W	C060012265050S		
R127FR	00D 963 9005 642	R,METAL FILM 1.2K-J,1W	C060012265050S		
R127SL	00D 963 9005 642	R,METAL FILM 1.2K-J,1W	C060012265050S		
R127SR	00D 963 9005 642	R,METAL FILM 1.2K-J,1W	C060012265050S		
R132C	00D 960 9010 719	R,METAL FILM 47-J,1W	C060047065060S		
R132FL	00D 960 9010 719	R,METAL FILM 47-J,1W	C060047065060S		
R132FR	00D 960 9010 719	R,METAL FILM 47-J,1W	C060047065060S		
R132SL	00D 960 9010 719	R,METAL FILM 47-J,1W	C060047065060S		
R132SR	00D 960 9010 719	R,METAL FILM 47-J,1W	C060047065060S		
R147-149	00D 963 9005 642	R,METAL FILM 1.2K-J,1W	C060012265050S		
VR101C	00D 960 0221 109	VR,SEMI CARBON EVN-DJAA03B	C541102115000S		
VR101FL	00D 960 0221 109	VR,SEMI CARBON EVN-DJAA03B	C541102115000S		
VR101FR	00D 960 0221 109	VR,SEMI CARBON EVN-DJAA03B	C541102115000S		

Ref. No.	Part No.	Part Name	Remarks	Q'ty	New
VR101SL	00D 960 0221 109	VR,SEMI CARBON EVN-DJAA03B	C541102115000S		
VR101SR	00D 960 0221 109	VR,SEMI CARBON EVN-DJAA03B	C541102115000S		
CAPACITORS GROUP					
C101	00D 963 9005 804	C,ELECT 100UF-M/25V	D040101084060S		
C101C	00D 963 0234 506	C,ELECT 47UF-M/50V (Pb Free)	D040470087070S		
C101FL	00D 963 0234 506	C,ELECT 47UF-M/50V (Pb Free)	D040470087070S		
C101FR	00D 963 0234 506	C,ELECT 47UF-M/50V (Pb Free)	D040470087070S		
C101SL	00D 963 0234 506	C,ELECT 47UF-M/50V (Pb Free)	D040470087070S		
C101SR	00D 963 0234 506	C,ELECT 47UF-M/50V (Pb Free)	D040470087070S		
C102	00D 963 0224 503	C,ELECT 22UF-M/50V	D040220087060S		
C102C	00D 963 0234 205	C,ELECT 10UF-M/50V	D040100087070S		
C102FL	00D 960 9010 133	C,ELECT 220UF-M/35V	D040221085060S		
C102FR	00D 960 9010 133	C,ELECT 220UF-M/35V	D040221085060S		
C102SL	00D 963 0234 205	C,ELECT 10UF-M/50V	D040100087070S		
C102SR	00D 963 0234 205	C,ELECT 10UF-M/50V	D040100087070S		
C103	00D 963 9006 557	C,ELECT 220UF-M/6.3V	D040221081060S		
C103C	00D 963 9003 084	C,CERAMIC 100PF-K/500V	D00410106D050S		
C103FL	00D 963 9003 084	C,CERAMIC 100PF-K/500V	D00410106D050S		
C103FR	00D 963 9003 084	C,CERAMIC 100PF-K/500V	D00410106D050S		
C103SL	00D 963 9003 084	C,CERAMIC 100PF-K/500V	D00410106D050S		
C103SR	00D 963 9003 084	C,CERAMIC 100PF-K/500V	D00410106D050S		
C104	00D 963 9006 557	C,ELECT 220UF-M/6.3V	D040221081060S		
C104C	00D 963 9003 084	C,CERAMIC 100PF-K/500V	D00410106D050S		
C104FL	00D 963 9003 084	C,CERAMIC 100PF-K/500V	D00410106D050S		
C104FR	00D 963 9003 084	C,CERAMIC 100PF-K/500V	D00410106D050S		
C104SL	00D 963 9003 084	C,CERAMIC 100PF-K/500V	D00410106D050S		
C104SR	00D 963 9003 084	C,CERAMIC 100PF-K/500V	D00410106D050S		
C105	00D 963 9006 557	C,ELECT 220UF-M/6.3V	D040221081060S		
C105C	nsp	C,CERAMIC 0.022UF-Z/50V	D011223597160S		
C105FL	nsp	C,CERAMIC 0.022UF-Z/50V	D011223597160S		
C105FR	nsp	C,CERAMIC 0.022UF-Z/50V	D011223597160S		
C105SL	nsp	C,CERAMIC 0.022UF-Z/50V	D011223597160S		
C105SR	nsp	C,CERAMIC 0.022UF-Z/50V	D011223597160S		
C106	00D 963 0293 709	C,ELECT 100UF-M/10V	D040101082070S		
C107	nsp	C,CERAMIC 0.01UF-K/50V	D011103777160S		
C107C	00D 963 9003 097	C,FILM 0.1UF-K/250V	D02010407H080S		
C107FL	00D 963 9003 097	C,FILM 0.1UF-K/250V	D02010407H080S		
C107FR	00D 963 9003 097	C,FILM 0.1UF-K/250V	D02010407H080S		
C107SL	00D 963 9003 097	C,FILM 0.1UF-K/250V	D02010407H080S		
C107SR	00D 963 9003 097	C,FILM 0.1UF-K/250V	D02010407H080S		
C108	00D 963 0149 400	CAP.E.GENERIC 10000UF/63V	N211210388110S		
C108C	00D 963 9006 544	C,ELECT 22UF-M/25V	D040220084050S		
C108FL	00D 963 9006 544	C,ELECT 22UF-M/25V	D040220084050S		
C108FR	00D 963 9006 544	C,ELECT 22UF-M/25V	D040220084050S		
C108SL	00D 963 9006 544	C,ELECT 22UF-M/25V	D040220084050S		
C108SR	00D 963 9006 544	C,ELECT 22UF-M/25V	D040220084050S		
C109	00D 963 0149 400	CAP.E.GENERIC 10000UF/63V	N211210388110S		
C109C	00D 963 0234 205	C,ELECT 10UF-M/50V	D040100087070S		
C109FL	00D 963 0234 205	C,ELECT 10UF-M/50V	D040100087070S		
C109FR	00D 963 0234 205	C,ELECT 10UF-M/50V	D040100087070S		
C109SL	00D 963 0234 205	C,ELECT 10UF-M/50V	D040100087070S		
C109SR	00D 963 0234 205	C,ELECT 10UF-M/50V	D040100087070S		
C110	00D 963 9003 097	C,FILM 0.1UF-K/250V	D02010407H080S		
C110C	00D 963 0338 208	C,CERAMIC 470PF-K/500V	D00447127D050S		

Ref. No.	Part No.	Part Name	Remarks	Q'ty	New
C110FL	00D 963 0338 208	C,CERAMIC 470PF-K/500V	D00447127D050S		
C110FR	00D 963 0338 208	C,CERAMIC 470PF-K/500V	D00447127D050S		
C110SL	00D 963 0338 208	C,CERAMIC 470PF-K/500V	D00447127D050S		
C110SR	00D 963 0338 208	C,CERAMIC 470PF-K/500V	D00447127D050S		
C111	00D 963 9003 097	C,FILM 0.1UF-K/250V	D02010407H080S		
C111C	00D 963 0367 101	C,CERAMIC 220PF-J/500V	D00422106D05CS		
C111FL	00D 963 0367 101	C,CERAMIC 220PF-J/500V	D00422106D05CS		
C111FR	00D 963 0367 101	C,CERAMIC 220PF-J/500V	D00422106D05CS		
C111SL	00D 963 0367 101	C,CERAMIC 220PF-J/500V	D00422106D05CS		
C111SR	00D 963 0367 101	C,CERAMIC 220PF-J/500V	D00422106D05CS		
C112	00D 963 9003 097	C,FILM 0.1UF-K/250V	D02010407H080S		
C112C	00D 963 9003 194	C,FILM 0.0022UF-J/100V	D02022206C060S		
C112FL	00D 963 9003 194	C,FILM 0.0022UF-J/100V	D02022206C060S		
C112FR	00D 963 9003 194	C,FILM 0.0022UF-J/100V	D02022206C060S		
C112SL	00D 963 9003 194	C,FILM 0.0022UF-J/100V	D02022206C060S		
C112SR	00D 963 9003 194	C,FILM 0.0022UF-J/100V	D02022206C060S		
C113C	00D 963 0293 709	C,ELECT 100UF-M/10V	D040101082070S		
C113FL	00D 960 9010 133	C,ELECT 220UF-M/35V	D040221085060S		
C113FR	00D 960 9010 133	C,ELECT 220UF-M/35V	D040221085060S		
C113SL	00D 963 0293 709	C,ELECT 100UF-M/10V	D040101082070S		
C113SR	00D 963 0293 709	C,ELECT 100UF-M/10V	D040101082070S		
C114	00D 963 9003 097	C,FILM 0.1UF-K/250V	D02010407H080S		
C114C	00D 963 0216 100	C,CERAMIC 33PF-J/500V	D00033006D050S		
C114FL	00D 963 0216 100	C,CERAMIC 33PF-J/500V	D00033006D050S		
C114FR	00D 963 0216 100	C,CERAMIC 33PF-J/500V	D00033006D050S		
C114SL	00D 963 0216 100	C,CERAMIC 33PF-J/500V	D00033006D050S		
C114SR	00D 963 0216 100	C,CERAMIC 33PF-J/500V	D00033006D050S		
C115	00D 963 9003 097	C,FILM 0.1UF-K/250V	D02010407H080S		
C115SW	00D 963 9006 544	C,ELECT 22UF-M/25V	D040220084050S		
C117-120	nsp	C,CERAMIC 0.1UF-K/50V	D011104577160S		
C141SW1	00D 963 0234 205	C,ELECT 10UF-M/50V	D040100087070S		
C142SW1	nsp	C,CERAMIC 100PF-J/50V	D010101167160S		
C161	00D 963 0234 205	C,ELECT 10UF-M/50V	D040100087070S		
C162,163	nsp	C,CERAMIC 0.01UF-K/50V	D011103777160S		
C164-167	nsp	C,CERAMIC 100PF-J/50V	D010101167160S		
C168-172	00D 963 0244 606	C,ELECT 0.1UF-M/50V (Pb Free)	D040R10087080S		
C177	nsp	C,CERAMIC 0.01UF-K/50V	D011103777160S		
C178,179	00D 960 9010 010	C,ELECT 4.7UF-M/50V	D0404R7087250S		
C180,181	nsp	C,CERAMIC 0.01UF-K/50V	D011103777160S		
C182	00D 963 0324 005	C,ELECT 100UF-M/100V	D04010108C240S		
C183	00D 963 0293 602	C,ELECT 1UF-M/50V (Pb Free)	D040010087150S		
C190	00D 960 9010 010	C,ELECT 4.7UF-M/50V	D0404R7087250S		
OTHERS PARTS GROUP					
BKT101	nsp	SHIELD PLATE GND	3070045526010S		
CN101	nsp	CN,WIRE 110MM/10P	L000111100070S		
CN103	nsp	CN,WIRE 120MM/7P	L000121070060S		
CN201	nsp	CN,WIRE 70MM/6P	L000700060110S		
CN511	nsp	CN,WIRE 60MM/9P	L000600090020S		
CN704	nsp	CN,WIRE 15P	L000600150030S		
CP103	nsp	CN.WAFER 3P	L102526700300S		
CP104	nsp	CN.WAFER 3CKT	L108353280360S		
CP106	nsp	CN.WAFER 5P	L101100040510S		

Ref. No.	Part No.	Part Name	Remarks	Q'ty	New
CP107	nsp	CN.WAFER 3P	L102526700300S		
CP108	nsp	CN.WAFER 17P	L101100041710S		
CP541	nsp	CN.WAFER 3P	L101220030000S		
GND101	nsp	TERMINAL EARTH	3790040886000S		
JACK222	00D 963 0146 005	TER,RCA 1PIN	G600107A0000YS		
L101C	00D 963 0049 005	COIL INDUCTOR 0.5UH	D330R50000000S		
L101FL	00D 963 0049 005	COIL INDUCTOR 0.5UH	D330R50000000S		
L101FR	00D 963 0049 005	COIL INDUCTOR 0.5UH	D330R50000000S		
L101SL	00D 963 0049 005	COIL INDUCTOR 0.5UH	D330R50000000S		
L101SR	00D 963 0049 005	COIL INDUCTOR 0.5UH	D330R50000000S		
RLY541	00D 963 0218 506	RELAY BC3-24 24V 2A	G680240202040S		
TP101-105	nsp	CN.WAFER 3P	L101530140310S		
JP108	00D 963 0223 009	R,THICK 0-J,1/16W	C20000006M160S		
JP350-352	00D 963 0223 009	R,THICK 0-J,1/16W	C20000006M160S		

FRONT P.W.B. UNIT ASS'Y

	Ref. No.	Part No.	Part Name	Remarks	Q'ty	New
SEMICONDUCTORS GROUP						
	IC301	00D 963 0074 504	IC BU2090F-E2	J044209000010S		
	IC302	00D 262 3758 009	LC87F6D64A-QFP-E	J127876160010S		
▲	IC303	00D 960 0195 808	IC ICP-N15	J120001500030S		
	Q301-303	00D 963 0120 704	TR KRA102S	J520010200210S		
	Q304	00D 963 0121 606	TR KRC107S	J522107S00210S		
	Q305	00D 963 0102 803	TR 2SA933S	J5000933S0050S		
	Q306	00D 963 0120 801	TR KRC102S	J522010200210S		
	Q307-309	00D 963 0120 704	TR KRA102S	J520010200210S		
	Q310,311	00D 963 0120 801	TR KRC102S	J522010200210S		
	Q312	00D 960 0133 103	TR KSA916Y	J5000916Y0050S		
	Q542-546	00D 963 0121 208	TR KRC107M	J6020107M0010S		
	D301,302	00D 963 0020 309	D,SWITCHING 1SS133T	K000013300520S		
	D303	00D 963 0355 401	D,SWITCHING KDS4148U	K005041480030S		
	D304	00D 963 0020 309	D,SWITCHING 1SS133T	K000013300520S		
	D305-311	00D 963 0355 401	D,SWITCHING KDS4148U	K005041480030S		
	D312	00D 963 0328 409	D,SWITCHING 1N4007	K000400700010S		
	D313-316	00D 963 0355 401	D,SWITCHING KDS4148U	K005041480030S		
	D542	00D 963 0020 309	D,SWITCHING 1SS133T	K000013300520S		
	D543-545	00D 963 0355 401	D,SWITCHING KDS4148U	K005041480030S		
	D546	00D 963 0020 309	D,SWITCHING 1SS133T	K000013300520S		
	ZD302-305	00D 960 0095 500	D,ZENER MTZJ5.1B	K06005R144520S		
	ZD307,308	00D 960 0095 500	D,ZENER MTZJ5.1B	K06005R144520S		
	ZD309	00D 960 0095 801	D,ZENER MTZJ6.8B	K06006R844520S		
	ZD310,311	00D 963 0046 202	D,ZENER MTZJ18B	K06018R044520S		
	LED302-309	00D 960 0197 204	LED PI5-RD/HL50RDRF4T	K500052015010S		
	LED310	00D 963 0366 108	LED BL-BEG204-L 5PI	K500052004010S		
	FL301	00D 963 0257 305	DISPLAY,FLT HNA-16SM13T	K530161300020S		
RESISTORS GROUP						
	R372	00D 963 0215 907	R,METAL FILM 4.7-J,1W	C0604R7065050S		
	R378,379	00D 960 9009 270	R,METAL FILM 470-J,2W	C060047166520S		
	R501	00D 960 9003 700	R,METAL FILM 10-J,1/4W	C060010063050S		
	RP1-38	00D 963 0353 005	R,CHIP THICK 56K-J,1/16W	C20005636M160S		
	RG1-16	00D 963 0353 005	R,CHIP THICK 56K-J,1/16W	C20005636M160S		
CAPACITORS GROUP						
	C301,302	nsp	C,CERAMIC 100PF-J/50V	D010101167160S		
	C303	nsp	C,CERAMIC 0.022UF-K/25V	D011223777160S		
	C304	00D 963 9005 862	C,ELECT 47UF-M/16V	D040470083080S		
	C305	nsp	C,CERAMIC 100PF-J/50V	D010101167160S		
	C306	nsp	C,CERAMIC 0.047UF-Z/50V	D011473597160S		
	C307	00D 963 9005 862	C,ELECT 47UF-M/16V	D040470083080S		
	C308	nsp	C,CERAMIC 0.01UF-K/50V	D011103777160S		
	C311	00D 963 0233 303	C,CERAMIC 0.01UF-M/16V	D005103773530S		
	C312	00D 963 9005 862	C,ELECT 47UF-M/16V	D040470083080S		

Ref. No.	Part No.	Part Name	Remarks	Q'ty	New
C316,317	nsp	C,CERAMIC 330PF-J/50V	D010331167160S		
C319,320	nsp	C,CERAMIC 0.01UF-K/50V	D011103777160S		
C321,322	00D 963 0233 303	C,CERAMIC 0.01UF-M/16V	D005103773530S		
C324,325	00D 963 0293 602	C,ELECT 1UF-M/50V (Pb Free)	D040010087150S		
C326	00D 963 9005 862	C,ELECT 47UF-M/16V	D040470083080S		
C327,328	nsp	C,CERAMIC 0.1UF-K/50V	D011104577160S		
C329	nsp	C,FILM 0.1UF-J/100V	D02010406C060S		
C330	00D 963 0021 900	C,FILM 0.047UF-J/100V	D02047306C060S		
C333	00D 963 0293 602	C,ELECT 1UF-M/50V (Pb Free)	D040010087150S		
C334	00D 963 0021 900	C,FILM 0.047UF-J/100V	D02047306C060S		
C339	nsp	C,CERAMIC 100PF-J/50V	D010101167160S		
C340	nsp	C,CERAMIC 1000PF-K/50V	D011102777160S		
C341,342	nsp	C,CERAMIC 100PF-J/50V	D010101167160S		
C343	00D 963 0020 202	C,CERAMIC 0.1UF-Z/50V	D005104597530S		
C344,345	00D 963 0233 206	C,CERAMIC 0.001UF-K/50V	D005102177530S		
C346-349	nsp	C,CERAMIC 0.01UF-K/50V	D011103777160S		
C350	00D 963 0021 900	C,FILM 0.047UF-J/100V	D02047306C060S		
C351	00D 963 0293 602	C,ELECT 1UF-M/50V (Pb Free)	D040010087150S		
C352	00D 963 0234 205	C,ELECT 10UF-M/50V	D040100087070S		
C353,354	00D 963 0293 602	C,ELECT 1UF-M/50V (Pb Free)	D040010087150S		
C355	nsp	C,ELECT 470UF-M/63V	D040471088010S		
C356	00D 963 9003 097	C,FILM 0.1UF-K/250V	D02010407H080S		
C357,358	nsp	C,CERAMIC 0.047UF-Z/50V	D011473597160S		
C541	nsp	C,CERAMIC 2200PF-K/50V	D011222777160S		
C541FL	00D 963 0024 703	C,FILM 0.01UF-J/100V	D02010306C060S		
C542	nsp	C,CERAMIC 2200PF-K/50V	D011222777160S		
C542FR	00D 963 0024 703	C,FILM 0.01UF-J/100V	D02010306C060S		
C543	nsp	C,CERAMIC 2200PF-K/50V	D011222777160S		
C543FL	00D 963 0024 703	C,FILM 0.01UF-J/100V	D02010306C060S		
C544	nsp	C,CERAMIC 2200PF-K/50V	D011222777160S		
C544FR	00D 963 0024 703	C,FILM 0.01UF-J/100V	D02010306C060S		
C545	nsp	C,CERAMIC 2200PF-K/50V	D011222777160S		
C545C	00D 963 0024 703	C,FILM 0.01UF-J/100V	D02010306C060S		
C546	nsp	C,CERAMIC 2200PF-K/50V	D011222777160S		
C546SL	00D 963 0024 703	C,FILM 0.01UF-J/100V	D02010306C060S		
C547	nsp	C,CERAMIC 2200PF-K/50V	D011222777160S		
C547SR	00D 963 0024 703	C,FILM 0.01UF-J/100V	D02010306C060S		
C548	nsp	C,CERAMIC 2200PF-K/50V	D011222777160S		
C548SBL	00D 963 0024 703	C,FILM 0.01UF-J/100V	D02010306C060S		
C549	nsp	C,CERAMIC 2200PF-K/50V	D011222777160S		
C549SBR	00D 963 0024 703	C,FILM 0.01UF-J/100V	D02010306C060S		
OTHERS PARTS GROUP					
BD301-304	nsp	COIL,BEAD MB-160808	D340160800060S		
CN102	nsp	CN,WIRE 270,170MM/4P	L000271040040S		
CN301	nsp	CN,WIRE 2P	L000401020050S		
CN303A	nsp	CN,WIRE 8P	L000450080010S		
CN304	nsp	CN,WIRE 3P	L000500030050S		
CN305	nsp	CN,WIRE 10P	L000700100030S		
CN541	nsp	CN,WIRE 3P	L000251030080S		
CP101	nsp	CN.WAFER 10P	L102526701000S		
CP103	nsp	CN.WAFER 7P	L101220070000S		
CP105	nsp	CN.WAFER 4P ANGLE	L102526800400S		

Ref. No.	Part No.	Part Name	Remarks	Q'ty	New
CP301B	00D 963 0368 506	CN.FPC 35P	L131103500010S		
CP302	nsp	CN.WAFER 3P ANGLE	L102526803010S		
CP304	nsp	CN.WAFER 3P	L101220030000S		
CP305		CN.WAFER 10P	L101220100010S		
CP306	nsp	CN.WAFER 3P	L101220030010S		
G301	nsp	RING,TER WIRE 120MM/1P	8410121010060S		
G302	nsp	RING,TER WIRE 120MM/1P	8410121010110S		
G304	nsp	RING,TER WIRE 70MM/1P	8410700010070S		
JACK304	00D 963 0146 403	TER,RCA 3PIN	G606308HG110YS		
JACK501,502	00D 963 0146 607	TER,BOARD SCREW 8P	G614801A0200YS		
JACK503	00D 963 0158 608	TER,BOARD SCREW 2P	G611201A0200YS		
JK302	00D 963 0294 708	JACK,D6.5 PHONE	G402PJ612AG0YS		
L302	nsp	COIL INDUCTOR 10UH	D330100700520S		
L303	nsp	COIL INDUCTOR 100UH	D330101001020S		
RLY541	00D 963 0366 201	RELAY G5PA-28-MC 24V 5A	G680240502030S		
RLY543-546	00D 963 0366 201	RELAY G5PA-28-MC 24V 5A	G680240502030S		
RMC301	00D 963 0217 808	MODULE,REMOCON NJL34H380A	E940343800010S		
⚠ SW301	00D 963 0145 802	SW,PUSH SDDL-005-S(C-UL)	G000122006060S		
SW301A	00D 963 0095 305	SW,TACT SKHV10910D01	G180040500010S		
SW301C	00D 963 0095 305	SW,TACT SKHV10910D01	G180040500010S		
SW302A	00D 963 0095 305	SW,TACT SKHV10910D01	G180040500010S		
SW302B	00D 963 0095 305	SW,TACT SKHV10910D01	G180040500010S		
SW302C	00D 963 0095 305	SW,TACT SKHV10910D01	G180040500010S		
SW303A	00D 963 0095 305	SW,TACT SKHV10910D01	G180040500010S		
SW303B	00D 963 0095 305	SW,TACT SKHV10910D01	G180040500010S		
SW303C	00D 963 0095 305	SW,TACT SKHV10910D01	G180040500010S		
SW304A	00D 963 0095 305	SW,TACT SKHV10910D01	G180040500010S		
SW304B	00D 963 0095 305	SW,TACT SKHV10910D01	G180040500010S		
SW304C	00D 963 0095 305	SW,TACT SKHV10910D01	G180040500010S		
SW305A	00D 963 0095 305	SW,TACT SKHV10910D01	G180040500010S		
SW305B	00D 963 0095 305	SW,TACT SKHV10910D01	G180040500010S		
SW305C	00D 963 0095 305	SW,TACT SKHV10910D01	G180040500010S		
SW306A	00D 963 0095 305	SW,TACT SKHV10910D01	G180040500010S		
SW306B	00D 963 0095 305	SW,TACT SKHV10910D01	G180040500010S		
SW306C	00D 963 0095 305	SW,TACT SKHV10910D01	G180040500010S		
SW307A	00D 963 0095 305	SW,TACT SKHV10910D01	G180040500010S		
SW307B	00D 963 0095 305	SW,TACT SKHV10910D01	G180040500010S		
SW307C	00D 963 0095 305	SW,TACT SKHV10910D01	G180040500010S		
SW308A	00D 963 0095 305	SW,TACT SKHV10910D01	G180040500010S		
SW308B	00D 963 0095 305	SW,TACT SKHV10910D01	G180040500010S		
SW308C	00D 963 0095 305	SW,TACT SKHV10910D01	G180040500010S		
SW309A	00D 963 0095 305	SW,TACT SKHV10910D01	G180040500010S		
SW310	00D 963 0095 305	SW,TACT SKHV10910D01	G180040500010S		
VEC203	00D 963 0300 401	SW,ENCODER EC11B20C2	G121112020000S		
VEC301	00D 963 0095 208	SW,ENCODER EC16B24SO	G121162400070S		
VEC303	00D 963 0095 208	SW,ENCODER EC16B24SO	G121162400070S		
	nsp	HOLDER FLT	4320200026000S		

INPUT P.W.B. UNIT ASS'Y

Ref. No.	Part No.	Part Name	Remarks	Q'ty	New
SEMICONDUCTORS GROUP					
IC700	00D 963 0366 304	IC R2A15215FP		J084152150010S	
IC702	00D 963 0024 004	IC NJM2068M		J121206800020S	
IC705-718	00D 963 0024 004	IC NJM2068M		J121206800020S	
Q700,701	00D 960 0196 807	TR 2SK117Y		J5441170Y0050S	
Q702	00D 963 0120 704	TR KRA102S		J520010200210S	
Q703	00D 960 0285 006	TR KRC104S		J522104S00210S	
D700,701	00D 963 0355 401	D,SWITCHING KDS4148U		K005041480030S	
ZD700,701	00D 960 0222 603	D,ZENER MTZJ7.5A		K06007R544530S	
RESISTORS GROUP					
R706-709	00D 963 9005 639	R,METAL FILM 100-J,1W		C060010165060S	
R791VC	nsp	R,METAL FILM 120-J,1W		C060012165060S	
R791VE	nsp	R,METAL FILM 120-J,1W		C060012165060S	
CAPACITORS GROUP					
C700	00D 963 0234 205	C,ELECT 10UF-M/50V		D040100087070S	
C702SW	00D 960 9010 010	C,ELECT 4.7UF-M/50V		D0404R7087250S	
C703C	nsp	C,CERAMIC 0.047UF-Z/50V		D011473597160S	
C703SW	nsp	C,CERAMIC 0.047UF-Z/50V		D011473597160S	
C704,705	00D 963 9005 875	C,ELECT 47UF-M/25V		D040470084070S	
C706FL	00D 963 9005 875	C,ELECT 47UF-M/25V		D040470084070S	
C706FR	00D 963 9005 875	C,ELECT 47UF-M/25V		D040470084070S	
C707FL	00D 963 0234 205	C,ELECT 10UF-M/50V		D040100087070S	
C707FR	00D 963 0234 205	C,ELECT 10UF-M/50V		D040100087070S	
C707SW	00D 963 0234 205	C,ELECT 10UF-M/50V		D040100087070S	
C708FL	nsp	C,CERAMIC 33PF-J/50V		D010330167160S	
C708FR	nsp	C,CERAMIC 33PF-J/50V		D010330167160S	
C708SW	nsp	C,CERAMIC 47PF-J/50V		D010470167160S	
C709FL	nsp	C,CERAMIC 0.047UF-Z/50V		D011473597160S	
C709FR	nsp	C,CERAMIC 0.047UF-Z/50V		D011473597160S	
C709SW	nsp	C,CERAMIC 0.047UF-Z/50V		D011473597160S	
C710	00D 963 0223 009	R,THICK 0-J,1/16W		C20000006M160S	
C710FL	nsp	C,CERAMIC 100PF-J/50V		D010101167160S	
C710FR	nsp	C,CERAMIC 100PF-J/50V		D010101167160S	
C710SW	nsp	C,CERAMIC 100PF-J/50V		D010101167160S	
C711	00D 963 0223 009	R,THICK 0-J,1/16W		C20000006M160S	
C711FL	nsp	C,CERAMIC 0.047UF-Z/50V		D011473597160S	
C711FR	nsp	C,CERAMIC 0.047UF-Z/50V		D011473597160S	
C711SW	nsp	C,CERAMIC 0.047UF-Z/50V		D011473597160S	
C712	00D 963 0293 602	C,ELECT 1UF-M/50V (Pb Free)		D040010087150S	
C713-715	00D 963 0223 009	R,THICK 0-J,1/16W		C20000006M160S	
C716-727	00D 960 9009 814	C,CERAMIC 330PF-J/50V		D010331167160S	
C728-731	nsp	C,CERAMIC 20PF-J/50V		D010200167160S	
C732-739	00D 960 9009 814	C,CERAMIC 330PF-J/50V		D010331167160S	
C740-751	00D 963 0234 205	C,ELECT 10UF-M/50V		D040100087070S	
C751A	00D 963 0234 205	C,ELECT 10UF-M/50V		D040100087070S	
C751B	00D 963 0234 205	C,ELECT 10UF-M/50V		D040100087070S	
C751C	00D 963 0234 205	C,ELECT 10UF-M/50V		D040100087070S	
C751D	00D 963 0234 205	C,ELECT 10UF-M/50V		D040100087070S	

Ref. No.	Part No.	Part Name	Remarks	Q'ty	New
C751E	00D 963 0234 205	C,ELECT 10UF-M/50V	D040100087070S		
C751F	00D 963 0234 205	C,ELECT 10UF-M/50V	D040100087070S		
C751G	00D 963 0234 205	C,ELECT 10UF-M/50V	D040100087070S		
C751H	00D 963 0234 205	C,ELECT 10UF-M/50V	D040100087070S		
C751J	00D 963 0234 205	C,ELECT 10UF-M/50V	D040100087070S		
C751K	00D 963 0234 205	C,ELECT 10UF-M/50V	D040100087070S		
C751L	00D 963 0234 205	C,ELECT 10UF-M/50V	D040100087070S		
C751M	00D 963 0234 205	C,ELECT 10UF-M/50V	D040100087070S		
C751N	00D 963 0234 205	C,ELECT 10UF-M/50V	D040100087070S		
C751P	00D 963 0234 205	C,ELECT 10UF-M/50V	D040100087070S		
C751Q	00D 963 0234 205	C,ELECT 10UF-M/50V	D040100087070S		
C751R	00D 963 0234 205	C,ELECT 10UF-M/50V	D040100087070S		
C751S	00D 963 0234 205	C,ELECT 10UF-M/50V	D040100087070S		
C751T	00D 963 0234 205	C,ELECT 10UF-M/50V	D040100087070S		
C751U	00D 963 0234 205	C,ELECT 10UF-M/50V	D040100087070S		
C751V	00D 963 0234 205	C,ELECT 10UF-M/50V	D040100087070S		
C752	00D 963 0234 205	C,ELECT 10UF-M/50V	D040100087070S		
C752A	nsp	C,CERAMIC 0.047UF-Z/50V	D011473597160S		
C752B	nsp	C,CERAMIC 0.047UF-Z/50V	D011473597160S		
C752C	nsp	C,CERAMIC 0.047UF-Z/50V	D011473597160S		
C752D	nsp	C,CERAMIC 0.047UF-Z/50V	D011473597160S		
C752E	nsp	C,CERAMIC 0.047UF-Z/50V	D011473597160S		
C752F	nsp	C,CERAMIC 0.047UF-Z/50V	D011473597160S		
C752G	nsp	C,CERAMIC 0.047UF-Z/50V	D011473597160S		
C752H	nsp	C,CERAMIC 0.047UF-Z/50V	D011473597160S		
C752J	nsp	C,CERAMIC 0.047UF-Z/50V	D011473597160S		
C752K	nsp	C,CERAMIC 0.047UF-Z/50V	D011473597160S		
C752L	nsp	C,CERAMIC 0.047UF-Z/50V	D011473597160S		
C752M	nsp	C,CERAMIC 0.047UF-Z/50V	D011473597160S		
C752N	nsp	C,CERAMIC 0.047UF-Z/50V	D011473597160S		
C752P	nsp	C,CERAMIC 0.047UF-Z/50V	D011473597160S		
C752Q	nsp	C,CERAMIC 0.047UF-Z/50V	D011473597160S		
C752R	nsp	C,CERAMIC 0.047UF-Z/50V	D011473597160S		
C752S	nsp	C,CERAMIC 0.047UF-Z/50V	D011473597160S		
C752T	nsp	C,CERAMIC 0.047UF-Z/50V	D011473597160S		
C752U	nsp	C,CERAMIC 0.047UF-Z/50V	D011473597160S		
C752V	nsp	C,CERAMIC 0.047UF-Z/50V	D011473597160S		
C752W	nsp	C,CERAMIC 0.1UF-Z/50V	D011104597160S		
C752X	nsp	C,CERAMIC 0.1UF-Z/50V	D011104597160S		
C753-771	00D 963 0234 205	C,ELECT 10UF-M/50V	D040100087070S		
C772,773	00D 963 0293 806	C,ELECT 100UF-M/10V (Pb Free)	D040101082090S		
C774	nsp	C,FILM 0.15UF-K/63V	D020154078060S		
C775	00D 963 0021 900	C,FILM 0.047UF-J/100V	D02047306C060S		
C776	00D 960 9008 640	C,FILM 0.022UF-J/100V	D02022306C060S		
C777	00D 963 0234 205	C,ELECT 10UF-M/50V	D040100087070S		
C778,779	nsp	C,CERAMIC 100PF-J/50V	D010101167160S		
C780	00D 963 0234 205	C,ELECT 10UF-M/50V	D040100087070S		
C781	00D 960 9008 640	C,FILM 0.022UF-J/100V	D02022306C060S		
C782	00D 963 0021 900	C,FILM 0.047UF-J/100V	D02047306C060S		
C783	nsp	C,FILM 0.15UF-K/63V	D020154078060S		
C784-790	00D 963 0293 806	C,ELECT 100UF-M/10V (Pb Free)	D040101082090S		
C791-793	00D 963 0234 205	C,ELECT 10UF-M/50V	D040100087070S		
C794	00D 963 0293 806	C,ELECT 100UF-M/10V (Pb Free)	D040101082090S		
C795-799	00D 963 0234 205	C,ELECT 10UF-M/50V	D040100087070S		
C800,801	00D 960 9010 832	C,ELECT 10UF-M/16V	D040100083050S		

Ref. No.	Part No.	Part Name	Remarks	Q'ty	New
OTHERS PARTS GROUP					
CLAMP501	nsp	CLAMP WIRE(SOLDER)		4330000120000S	
CN306	nsp	CN,WIRE 480MM/3P		L000481030060S	
CN514	nsp	CN,WIRE 13P		L000181130010S	
CN702	nsp	CN.HOUSING 15P		L120912150010S	
CN703	nsp	CN.WAFER 8P		L101100030810S	
CN704	nsp	CN.WAFER 19P		L101100031910S	
CN706	nsp	CN,WIRE 8P		L000121050080S	
CP704	nsp	CN.WAFER 15P		L101220150000S	
JACK701	00D 963 0132 103	TER,RCA 4PIN		G602405B0400YS	
JACK702	00D 963 0387 505	TER,RCA 4PIN		G602405B5500YS	
JACK703	00D 963 0132 103	TER,RCA 4PIN		G602405B0400YS	
JACK704,705	00D 963 0132 307	TER,RCA 6PIN		G603603B05000S	

POWER P.W.B. UNIT ASS'Y

	Ref. No.	Part No.	Part Name	Remarks		Q'ty	New
SEMICONDUCTORS GROUP							
△	IC501	00D 963 0057 806	IC KIA78R05PI		J126780500370S		
	IC502	00D 960 0195 808	IC ICP-N15		J120001500030S		
	IC515	00D 960 0174 900	IC KIA7815API		J126781500000S		
	IC516	00D 963 0021 502	IC KIA7915PI		J126791500030S		
	IC517	00D 960 0100 301	IC KIA7812API		J126781200040S		
	Q501	00D 960 0196 409	TR 2SC1740SR		J5021740S0010S		
	Q502	00D 963 0121 208	TR KRC107M		J6020107M0010S		
	Q503	00D 960 0196 409	TR 2SC1740SR		J5021740S0010S		
	D501-503	00D 276 0401 905	D,SWITCHING 1SS133T		K000013300520S		
	D504-507	00D 963 0328 409	D,SWITCHING 1N4007		K000400700010S		
	D508,509	00D 276 0401 905	D,SWITCHING 1SS133T		K000013300520S		
	D521,522	00D 276 0401 905	D,SWITCHING 1SS133T		K000013300520S		
	D523-526	00D 963 0328 409	D,SWITCHING 1N4007		K000400700010S		
	ZD501	00D 960 0095 500	D,ZENER MTZJ5.1B		K06005R144520S		
	ZD502	00D 963 0219 903	D,ZENER MTZJ16B		K06016R044520S		
RESISTORS GROUP							
	R506	00D 963 0244 305	R,METAL FILM 2.2M 0.5W		C060022564520S		
	R507	00D 963 0232 809	R,METAL FILM 10-J,1/4W		C060010063520S		
	R516-519	00D 963 0216 003	R,METAL FILM 0.22-J,1W		C060R22065050S		
	R520	00D 963 0215 907	R,METAL FILM 4.7-J,1W		C0604R7065050S		
CAPACITORS GROUP							
	C501	00D 963 0234 205	C,ELECT 10UF-M/50V		D040100087070S		
	C502	00D 963 0217 002	C,ELECT 3300UF-M/16V		D040332083010S		
	C503	00D 963 0293 602	C,ELECT 1UF-M/50V (Pb Free)		D040010087150S		
	C504	00D 963 0323 802	C,CERAMIC AC(SAFETY) 0.0047UF 250VAC		D00847208H010S		
	C506	00D 963 0293 602	C,ELECT 1UF-M/50V (Pb Free)		D040010087150S		
	C526,527	00D 960 0186 202	C,ELECT 220UF-M/35V		D040221085050S		
	C528	00D 963 0324 908	C,ELECT 4700UF-M/35V		D040472085020S		
	C529	00D 963 0224 707	C,ELECT 2200UF-M/35V		D040222085020S		
	C530-532	00D 963 0021 900	C,FILM 0.047UF-J/100V		D02047306C060S		
	C534,535	00D 963 0234 205	C,ELECT 10UF-M/50V		D040100087070S		
OTHERS PARTS GROUP							
	BKT501	nsp	SHIELD PLATE GND		3070045526010S		
	CLAMP102-105	nsp	CLAMP WIRE(SOLDER)		4330000120000S		
	CN505	nsp	CN.WAFER 7P		L101100030710S		
	CN506	nsp	CN.WAFER 12P		L101100031210S		
	CN511	nsp	CN,WIRE 9P		L000600090020S		
	CP501	nsp	CN.WAFER 2CKT,YEL		L108353280290S		
	CP503	nsp	CN.WAFER 2CKT,RED		L108353280280S		
	CP504	nsp	CN.WAFER ST2P		L108202000220S		
	CP505	nsp	CN.WAFER 7P		L101100040710S		

	Ref. No.	Part No.	Part Name	Remarks		Q'ty	New
	CP506	nsp	CN.WAFER 12P		L101100041210S		
	CP511	nsp	CN.WAFER 9P		L101220090000S		
	CP513	nsp	CN.WAFER 3P ANGLE		L102526803010S		
	CP514	nsp	CN.WAFER 13P		L101220130000S		
⚠	F501	00D 963 0236 106	FUSE T8A /250V		N751228001110S		
	F501A	nsp	HOLDER,FUSE CLIP		G645000050010S		
	F501B	nsp	HOLDER,FUSE CLIP		G645000050010S		
⚠	F503	00D 963 0236 106	FUSE T8A /250V		N751228001110S		
	F503A	nsp	HOLDER,FUSE CLIP		G645000050010S		
	F503B	nsp	HOLDER,FUSE CLIP		G645000050010S		
	GND501	nsp	TERMINAL EARTH		3790040886000S		
	RLY501	00D 963 0218 205	RELAY HL3-1A-9SH DC9V 1A		G680090102020S		
⚠	SUB501	00D 963 0387 602	SUB TRANS		8200280150401S		
		nsp	HEAT SINK		2120043538050S		
		nsp	HEAT SINK		2120044298010S		
		nsp	SCREW,TAP TITE +2S 3*8 B-TYPE ZNW/BH		B020030081B10S		
		00D 963 0328 409	D,SWITCHING 1N4007		K000400700010S		
⚠		00D 203 3976 002	SOCKET,POWER RECEP		G435204004010S		

2CH-AMP P.W.B. UNIT ASS'Y

Ref. No.	Part No.	Part Name	Remarks	Q'ty	New
SEMICONDUCTORS GROUP					
IC401D	00D 960 0159 501	IC KIA7805API,		J126780500110S	
IC401H	00D 963 0388 805	CN,WIRE 110MM/3P		L000111030040S	
IC402D	00D 963 0226 608	IC KIA78R33PI		J12678R330010S	
IC402X	00D 963 0366 603	IC KIA1117PI50		J126111750050S	
IC403	00D 263 1223 005	PQ20RX11J00H		J126201100010S	
IC403D	00D 963 0366 706	IC KIA1117PI00		J126111700050S	
Q401SBL	00D 996 0018 706	TR 2SD2390-Y		J5032390Y0000S	
Q401SBR	00D 996 0018 706	TR 2SD2390-Y		J5032390Y0000S	
Q401X	00D 963 0120 801	TR KRC102S		J522010200210S	
Q402D	00D 960 0097 304	TR KRC102M		J6020102M0010S	
Q402SBL	00D 996 0018 706	TR 2SB1560-Y		J5011560Y0000S	
Q402SBR	00D 996 0018 706	TR 2SB1560-Y		J5011560Y0000S	
Q402X	00D 963 0120 801	TR KRC102S		J522010200210S	
Q403SBL	00D 963 0280 107	TR 2SC3964		J502396400000S	
Q403SBR	00D 963 0280 107	TR 2SC3964		J502396400000S	
Q404SBL	00D 960 0196 506	TR KSC1845F		J5021845F0000S	
Q404SBR	00D 960 0196 506	TR KSC1845F		J5021845F0000S	
Q405SBL	00D 273 0459 903	TR KTC2874B		J502287400010S	
Q405SBR	00D 273 0459 903	TR KTC2874B		J502287400010S	
Q406SBL	00D 960 0196 205	TR KSA992F		J5000992F0050S	
Q406SBR	00D 960 0196 205	TR KSA992F		J5000992F0050S	
Q407SBL	00D 960 0196 205	TR KSA992F		J5000992F0050S	
Q407SBR	00D 960 0196 205	TR KSA992F		J5000992F0050S	
Q408SBL	00D 960 0196 506	TR KSC1845F		J5021845F0000S	
Q408SBR	00D 960 0196 506	TR KSC1845F		J5021845F0000S	
Q409D	00D 960 0097 304	TR KRC102M		J6020102M0010S	
D401H	00D 963 0328 409	D,SWITCHING 1N4007		K000400700010S	
D401SBL	00D 963 0341 004	D,SWITCHING KDS4148U		K005041480030S	
D401SBR	00D 963 0341 004	D,SWITCHING KDS4148U		K005041480030S	
D401X	00D 963 0328 409	D,SWITCHING 1N4007		K000400700010S	
D402	00D 276 0401 905	D,SWITCHING 1SS133T		K000013300520S	
D402H	00D 963 0328 409	D,SWITCHING 1N4007		K000400700010S	
D402SBL	00D 963 0341 004	D,SWITCHING KDS4148U		K005041480030S	
D402SBR	00D 963 0341 004	D,SWITCHING KDS4148U		K005041480030S	
D402X	00D 963 0328 409	D,SWITCHING 1N4007		K000400700010S	
D403	00D 276 0401 905	D,SWITCHING 1SS133T		K000013300520S	
ZD401D	00D 960 0095 607	D,ZENER MTZJ5.6B		K06005R644520S	
ZD401SBL	00D 963 0367 008	D,ZENER 0.2W 3.3V UDZ		K06603R34P400S	
ZD401SBR	00D 963 0367 008	D,ZENER 0.2W 3.3V UDZ		K06603R34P400S	
ZD402SBL	00D 963 0367 008	D,ZENER 0.2W 3.3V UDZ		K06603R04P400S	
ZD402SBR	00D 963 0367 008	D,ZENER 0.2W 3.3V UDZ		K06603R04P400S	
RESISTORS GROUP					
R401D	00D 963 9006 269	R,FIXED 1WJ-0.22		N113135622820S	
R401H	00D 963 9006 269	R,FIXED 1WJ-0.22		N113135622820S	
R401X	00D 963 9006 269	R,FIXED 1WJ-0.22		N113135622820S	
R402D	00D 963 9006 269	R,FIXED 1WJ-0.22		N113135622820S	
R402H	00D 963 9006 269	R,FIXED 1WJ-0.22		N113135622820S	
R402X	00D 963 9006 269	R,FIXED 1WJ-0.22		N113135622820S	
R410SBL	00D 963 9005 642	R,METAL FILM 1.2K-J,1W		C060012265050S	

Ref. No.	Part No.	Part Name	Remarks		Q'ty	New
R410SBR	00D 963 9005 642	R,METAL FILM 1.2K-J,1W		C060012265050S		
R411SBL	00D 960 9010 719	R,METAL FILM 47-J,1W		C060047065060S		
R411SBR	00D 960 9010 719	R,METAL FILM 47-J,1W		C060047065060S		
R414SBL	00D 963 9006 285	R,FIXED 1WJ-5.6K		N113135656220S		
R414SBR	00D 963 9006 285	R,FIXED 1WJ-5.6K		N113135656220S		
R415SBL	00D 963 9006 285	R,FIXED 1WJ-5.6K		N113135656220S		
R415SBR	00D 963 9006 285	R,FIXED 1WJ-5.6K		N113135656220S		
R419SBL	00D 963 0215 907	R,METAL FILM 4.7-J,1W		C0604R7065050S		
R419SBR	00D 963 0215 907	R,METAL FILM 4.7-J,1W		C0604R7065050S		
R420SBL	00D 963 0215 907	R,METAL FILM 4.7-J,1W		C0604R7065050S		
R420SBR	00D 963 0215 907	R,METAL FILM 4.7-J,1W		C0604R7065050S		
R421SBL	00D 963 0345 903	R,FIXED 2WJ-0.47		N113136647820S		
R421SBR	00D 963 0345 903	R,FIXED 2WJ-0.47		N113136647820S		
R422SBL	00D 963 0345 903	R,FIXED 2WJ-0.47		N113136647820S		
R422SBR	00D 963 0345 903	R,FIXED 2WJ-0.47		N113136647820S		
R423SBL	00D 963 0345 903	R,FIXED 2WJ-0.47		N113136647820S		
R423SBR	00D 963 0345 903	R,FIXED 2WJ-0.47		N113136647820S		
R424SBL	00D 963 0345 903	R,FIXED 2WJ-0.47		N113136647820S		
R424SBR	00D 963 0345 903	R,FIXED 2WJ-0.47		N113136647820S		
R429SBL	00D 963 9006 256	R,FIXED 1WJ-10		N113135610020S		
R429SBR	00D 963 9006 256	R,FIXED 1WJ-10		N113135610020S		
R430SBL	00D 963 9006 256	R,FIXED 1WJ-10		N113135610020S		
R430SBR	00D 963 9006 256	R,FIXED 1WJ-10		N113135610020S		
VR401,402	00D 963 0366 407	VR,SEMI CARBON EVN-DCAA03B 1KB		C541102315000S		
CAPACITORS GROUP						
C401D	00D 963 0021 900	C,FILM 0.047UF-J/100V		D02047306C060S		
C401H	00D 963 0021 900	C,FILM 0.047UF-J/100V		D02047306C060S		
C401SBL	00D 963 9006 544	C,ELECT 22UF-M/25V		D040220084050S		
C401SBR	00D 963 9006 544	C,ELECT 22UF-M/25V		D040220084050S		
C401X	nsp	C,CERAMIC 0.1UF-K/50V		D011104577160S		
C402D	00D 963 0021 900	C,FILM 0.047UF-J/100V		D02047306C060S		
C402H	00D 963 0021 900	C,FILM 0.047UF-J/100V		D02047306C060S		
C402SBL	00D 963 0234 205	C,ELECT 10UF-M/50V		D040100087070S		
C402SBR	00D 963 0234 205	C,ELECT 10UF-M/50V		D040100087070S		
C402X	00D 963 9003 097	C,FILM 0.1UF-K/250V		D02010407H080S		
C403D	00D 963 0021 900	C,FILM 0.047UF-J/100V		D02047306C060S		
C403H	00D 963 0021 900	C,FILM 0.047UF-J/100V		D02047306C060S		
C403SBL	00D 963 0367 101	C,CERAMIC 220PF-J/500V		D00422106D05CS		
C403SBR	00D 963 0367 101	C,CERAMIC 220PF-J/500V		D00422106D05CS		
C403X	00D 960 0133 404	C,ELECT 1000UF 16V		D040103083020S		
C404D	00D 960 0133 404	C,ELECT 1000UF 16V		D040103083020S		
C404H	00D 963 0217 002	C,ELECT 3300UF-M/16V		D040332083010S		
C404SBL	00D 963 0338 208	C,CERAMIC 470PF-K/500V		D00447127D050S		
C404SBR	00D 963 0338 208	C,CERAMIC 470PF-K/500V		D00447127D050S		
C404X	00D 963 0276 409	C,ELECT 100UF-M/16V		D040101083090S		
C405D	00D 963 0338 402	C,ELECT 330UF-M/6.3V		D040331081050S		
C405SBL	00D 963 0216 100	C,CERAMIC 33PF-J/500V		D00033006D050S		
C405SBR	00D 963 0216 100	C,CERAMIC 33PF-J/500V		D00033006D050S		
C406D	nsp	C,CERAMIC 0.1UF-K/50V		D011104577160S		
C406SBL	00D 963 0293 709	C,ELECT 100UF-M/10V		D040101082070S		
C406SBR	00D 963 0293 709	C,ELECT 100UF-M/10V		D040101082070S		
C406X	nsp	C,CERAMIC 1000PF-K/50V		D011102777160S		
C407D	nsp	C,CERAMIC 1000PF-K/50V		D011102777160S		

Ref. No.	Part No.	Part Name	Remarks		Q'ty	New
C407SBL	00D 963 9003 194	C,FILM 0.0022UF-J/100V		D02022206C060S		
C407SBR	00D 963 9003 194	C,FILM 0.0022UF-J/100V		D02022206C060S		
C407X	00D 963 0293 709	C,ELECT 100UF-M/10V		D040101082070S		
C408D	00D 963 0338 402	C,ELECT 330UF-M/6.3V		D040331081050S		
C408SBL	00D 963 0234 506	C,ELECT 47UF-M/50V (Pb Free)		D040470087070S		
C408SBR	00D 963 0234 506	C,ELECT 47UF-M/50V (Pb Free)		D040470087070S		
C408X	00D 963 0293 709	C,ELECT 100UF-M/10V		D040101082070S		
C409D	nsp	C,CERAMIC 0.1UF-K/50V		D011104577160S		
C409SBL	00D 963 9003 084	C,CERAMIC 100PF-K/500V		D00410106D050S		
C409SBR	00D 963 9003 084	C,CERAMIC 100PF-K/500V		D00410106D050S		
C410D	00D 963 0338 402	C,ELECT 330UF-M/6.3V		D040331081050S		
C410SBL	00D 963 0234 205	C,ELECT 10UF-M/50V		D040100087070S		
C410SBR	00D 963 0234 205	C,ELECT 10UF-M/50V		D040100087070S		
C411D	nsp	C,CERAMIC 0.1UF-K/50V		D011104577160S		
C411SBL	00D 963 9003 084	C,CERAMIC 100PF-K/500V		D00410106D050S		
C411SBR	00D 963 9003 084	C,CERAMIC 100PF-K/500V		D00410106D050S		
C412D	nsp	C,CERAMIC 0.1UF-K/50V		D011104577160S		
C412SBL	nsp	C,CERAMIC 0.022UF-K/25V		D011223777160S		
C412SBR	nsp	C,CERAMIC 0.022UF-K/25V		D011223777160S		
C413D	00D 963 0024 907	C,ELECT 1000UF-M/6.3V		D040102081060S		
C413SBL	00D 963 9003 097	C,FILM 0.1UF-K/250V		D02010407H080S		
C413SBR	00D 963 9003 097	C,FILM 0.1UF-K/250V		D02010407H080S		
C443	nsp	C,CERAMIC 1000PF-K/50V		D011102777160S		
OTHERS PARTS GROUP						
CLAMP401	nsp	CLAMP WIRE(SOLDER)		4330000120000S		
CN203	nsp	CN,WIRE 160MM/3P		L000161030060S		
CN401A	nsp	CN,WIRE 5P		L000191050030S		
CN405	nsp	CN,WIRE 5P		L000321050020S		
CN705	nsp	CN,WIRE 150MM/3P		L000151030010S		
CN904	nsp	CN,WIRE 6P		L000141060030S		
CP102	nsp	CN.WAFER 3P		L102526700300S		
CP201	nsp	CN.WAFER 10P		L101220100000S		
CP402	nsp	CN.WAFER 3P		L102526700300S		
L401SBL	nsp	COIL INDUCTOR 0.5UH		D330R50000000S		
L401SBR	nsp	COIL INDUCTOR 0.5UH		D330R50000000S		
TP401,402	nsp	CN.WAFER 3P ANGLE		L101530150310S		
	00D 963 0328 409	D,SWITCHING 1N4007		K000400700010S		

CPU P.W.B. UNIT ASS'Y

Ref. No.	Part No.	Part Name	Remarks	Q'ty	New
SEMICONDUCTORS GROUP					
IC712-715	00D 963 0024 004	IC NJM2068M		J121206800020S	
IC804	963243000020D	IC,CPU MICRO PROCESS	M30626FHPFP	8952150800015	
IC806	00D 960 0100 301	IC KIA7812API		J126781200040S	
IC813	00D 963 0367 204	IC SN74HC151PWR		J040741510070S	
IC817	00D 963 0244 907	IC SN74LV14APWR		J040741400180S	
IC818	00D 963 0367 307	IC SN74AHCU04PWR		J040740400290S	
IC824	00D 963 0043 807	IC BA4510F-E2/SOP8		J121451000010S	
IC827	00D 963 0043 807	IC BA4510F-E2/SOP8		J121451000010S	
IC830	00D 262 2813 903	SN74AHCT08PW-EL2 +C		J040740800190S	
Q704C	00D 963 0044 301	TR KTC2875B(MB)	<div style="border: 1px solid black; border-radius: 15px; padding: 5px; width: fit-content;"> ファームウェアをアップデート するときは、SDIで最終バージョン を確認して下さい。 サービス基板はアップデートし て使用下さい。 When update Firmware, please confirm a last version in SDI. Use the service board after updating it. </div>	J5222875B0010S	
Q704FL	00D 963 0044 301	TR KTC2875B(MB)		J5222875B0010S	
Q704FR	00D 963 0044 301	TR KTC2875B(MB)		J5222875B0010S	
Q704SBL	00D 963 0044 301	TR KTC2875B(MB)		J5222875B0010S	
Q704SBR	00D 963 0044 301	TR KTC2875B(MB)		J5222875B0010S	
Q704SL	00D 963 0044 301	TR KTC2875B(MB)		J5222875B0010S	
Q704SR	00D 963 0044 301	TR KTC2875B(MB)		J5222875B0010S	
Q704SW	00D 963 0044 301	TR KTC2875B(MB)		J5222875B0010S	
Q801	00D 963 0120 704	TR KRA102S	J520010200210S		
Q802-805	00D 963 0044 301	TR KTC2875B(MB)		J5222875B0010S	
Q806	00D 963 0121 509	TR KTC3875S		J522038750210S	
Q807	00D 960 0285 006	TR KRC104S		J522104S00210S	
Q810D	00D 963 0245 100	D,SWITCHING KDS226ST1(C3)		K005022600020S	
Q811D	00D 963 0245 100	D,SWITCHING KDS226ST1(C3)		K005022600020S	
Q812D	00D 963 0120 801	TR KRC102S		J522010200210S	
Q813D	00D 963 0120 704	TR KRA102S		J520010200210S	
D801-804	00D 963 0355 401	D,SWITCHING KDS4148U		K005041480030S	
D805	00D 963 0328 409	D,SWITCHING 1N4007		K000400700010S	
D807	00D 963 0355 401	D,SWITCHING KDS4148U		K005041480030S	
D807D	00D 963 0355 401	D,SWITCHING KDS4148U		K005041480030S	
D808D	00D 963 0341 305	D,ESD IMSA-6802-01A		K067680200010S	
D809D	00D 963 0355 401	D,SWITCHING KDS4148U		K005041480030S	
D810D	00D 963 0341 305	D,ESD IMSA-6802-01A		K067680200010S	
D811D	00D 963 0341 305	D,ESD IMSA-6802-01A		K067680200010S	
ZD801	00D 963 0047 502	D,ZENER MTZJ3.3B		K06003R344520S	
RESISTORS GROUP					
R857	00D 960 9003 807	R,METAL 100-J,1/4W		C060010163050S	
CAPACITORS GROUP					
C751C	00D 963 0234 205	C,ELECT 10UF-M/50V		D040100087070S	
C751FL	00D 963 0234 205	C,ELECT 10UF-M/50V		D040100087070S	
C751FR	00D 963 0234 205	C,ELECT 10UF-M/50V		D040100087070S	
C751SBL	00D 963 0234 205	C,ELECT 10UF-M/50V		D040100087070S	
C751SBR	00D 963 0234 205	C,ELECT 10UF-M/50V		D040100087070S	
C751SL	00D 963 0234 205	C,ELECT 10UF-M/50V		D040100087070S	
C751SR	00D 963 0234 205	C,ELECT 10UF-M/50V		D040100087070S	
C751SW	00D 963 0234 205	C,ELECT 10UF-M/50V		D040100087070S	
C752C	00D 963 0350 503	C,CERAMIC 390PF-J/50V		D010391167160S	
C752FL	00D 963 0223 708	C,CERAMIC 270PF-J/50V		D010271167160S	

Ref. No.	Part No.	Part Name	Remarks		Q'ty	New
C752FR	00D 963 0223 708	C,CERAMIC 270PF-J/50V		D010271167160S		
C752SBL	00D 960 9009 814	C,CERAMIC 330PF-J/50V		D010331167160S		
C752SBR	00D 960 9009 814	C,CERAMIC 330PF-J/50V		D010331167160S		
C752SL	00D 960 9009 814	C,CERAMIC 330PF-J/50V		D010331167160S		
C752SR	00D 960 9009 814	C,CERAMIC 330PF-J/50V		D010331167160S		
C752SW	00D 963 0350 503	C,CERAMIC 390PF-J/50V		D010391167160S		
C753C	00D 963 0224 008	C,CERAMIC 470PF-J/50V		D010471167160S		
C753FL	00D 963 0223 902	C,CERAMIC 39PF-J/50V		D010390167160S		
C753FR	00D 963 0223 902	C,CERAMIC 39PF-J/50V		D010390167160S		
C753SBL	00D 963 0223 708	C,CERAMIC 270PF-J/50V		D010271167160S		
C753SBR	00D 963 0223 708	C,CERAMIC 270PF-J/50V		D010271167160S		
C753SL	00D 963 0223 708	C,CERAMIC 270PF-J/50V		D010271167160S		
C753SR	00D 963 0223 708	C,CERAMIC 270PF-J/50V		D010271167160S		
C753SW	00D 963 0224 008	C,CERAMIC 470PF-J/50V		D010471167160S		
C755C	nsp	C,CERAMIC 0.1UF-Z/50V		D011104597160S		
C755FL	nsp	C,CERAMIC 0.1UF-Z/50V		D011104597160S		
C755FR	nsp	C,CERAMIC 0.1UF-Z/50V		D011104597160S		
C755SBL	nsp	C,CERAMIC 0.1UF-Z/50V		D011104597160S		
C755SBR	nsp	C,CERAMIC 0.1UF-Z/50V		D011104597160S		
C755SL	nsp	C,CERAMIC 0.1UF-Z/50V		D011104597160S		
C755SR	nsp	C,CERAMIC 0.1UF-Z/50V		D011104597160S		
C755SW	nsp	C,CERAMIC 0.1UF-Z/50V		D011104597160S		
C756C	00D 963 9003 194	C,FILM 0.0022UF-J/100V		D02022206C060S		
C756FL	00D 963 9003 194	C,FILM 0.0022UF-J/100V		D02022206C060S		
C756FR	00D 963 9003 194	C,FILM 0.0022UF-J/100V		D02022206C060S		
C756SBL	00D 963 9003 194	C,FILM 0.0022UF-J/100V		D02022206C060S		
C756SBR	00D 963 9003 194	C,FILM 0.0022UF-J/100V		D02022206C060S		
C756SL	00D 963 9003 194	C,FILM 0.0022UF-J/100V		D02022206C060S		
C756SR	00D 963 9003 194	C,FILM 0.0022UF-J/100V		D02022206C060S		
C756SW	00D 963 9003 194	C,FILM 0.0022UF-J/100V		D02022206C060S		
C757C	nsp	C,CERAMIC 10UF-Z/10V		D011106592200S		
C757FL	nsp	C,CERAMIC 10UF-Z/10V		D011106592200S		
C757FR	nsp	C,CERAMIC 10UF-Z/10V		D011106592200S		
C757SBL	nsp	C,CERAMIC 10UF-Z/10V		D011106592200S		
C757SBR	nsp	C,CERAMIC 10UF-Z/10V		D011106592200S		
C757SL	nsp	C,CERAMIC 10UF-Z/10V		D011106592200S		
C757SR	nsp	C,CERAMIC 10UF-Z/10V		D011106592200S		
C757SW	nsp	C,CERAMIC 10UF-Z/10V		D011106592200S		
C803	nsp	C,CERAMIC 100PF-J/50V		D010101167160S		
C804,805	nsp	C,CERAMIC 0.1UF-Z/50V		D011104597160S		
C806	nsp	C,CERAMIC 0.01UF-K/50V		D011103777160S		
C807,808	nsp	C,CERAMIC 0.022UF-Z/50V		D011223597160S		
C809	00D 963 0293 709	C,ELECT 100UF-M/10V		D040101082070S		
C810	nsp	C,CERAMIC 0.1UF-Z/50V		D011104597160S		
C813	nsp	C,CERAMIC 0.1UF-Z/50V		D011104597160S		
C814-816	nsp	C,CERAMIC 0.01UF-K/50V		D011103777160S		
C818	00D 960 9010 010	C,ELECT 4.7UF-M/50V		D0404R7087250S		
C819	nsp	C,CERAMIC 0.01UF-K/50V		D011103777160S		
C824,825	00D 963 0234 205	C,ELECT 10UF-M/50V		D040100087070S		
C826-831	nsp	C,CERAMIC 100PF-J/50V		D010101167160S		
C836,837	nsp	C,CERAMIC 0.022UF-Z/50V		D011223597160S		
C865L	nsp	C,CERAMIC 120PF-J/50V		D010121167160S		
C865R	nsp	C,CERAMIC 120PF-J/50V		D010121167160S		
C871L	00D 963 0216 304	C,FILM 0.001UF-J/100V		D02010206C060S		
C871R	00D 963 0216 304	C,FILM 0.001UF-J/100V		D02010206C060S		
C916D	nsp	C,CERAMIC 0.1UF-Z/50V		D011104597160S		

Ref. No.	Part No.	Part Name	Remarks		Q'ty	New
C917D	nsp	C,CERAMIC 0.1UF-Z/50V		D011104597160S		
C918D	nsp	C,CERAMIC 0.1UF-Z/50V		D011104597160S		
C921D	nsp	C,CERAMIC 100PF-J/50V		D010101167160S		
C923D	nsp	C,CERAMIC 22PF-J/50V		D010220167160S		
C924D	nsp	C,CERAMIC 22PF-J/50V		D010220167160S		
C927D	00D 963 9005 862	C,ELECT 47UF-M/16V		D040470083080S		
C928D	00D 963 9005 862	C,ELECT 47UF-M/16V		D040470083080S		
C931D	nsp	C,CERAMIC 100PF-J/50V		D010101167160S		
C932D	nsp	C,CERAMIC 0.01UF-K/50V		D011103777160S		
C933D	nsp	C,CERAMIC 0.01UF-K/50V		D011103777160S		
C934D	nsp	C,CERAMIC 0.01UF-K/50V		D011103777160S		
C935D	00D 960 9010 010	C,ELECT 4.7UF-M/50V		D0404R7087250S		
C936D	00D 960 9010 010	C,ELECT 4.7UF-M/50V		D0404R7087250S		
C937D	nsp	C,CERAMIC 1000PF-K/50V		D011102777160S		
C938D	00D 960 9010 010	C,ELECT 4.7UF-M/50V		D0404R7087250S		
C939D	nsp	C,CERAMIC 0.01UF-K/50V		D011103777160S		
C940D	nsp	C,CERAMIC 0.01UF-K/50V		D011103777160S		
C941D	00D 963 0244 606	C,ELECT 0.1UF-M/50V (Pb Free)		D040R10087080S		
C950D	nsp	C,CERAMIC 0.1UF-Z/50V		D011104597160S		
C951D	nsp	C,CERAMIC 0.1UF-Z/50V		D011104597160S		
C952D	00D 963 0234 205	C,ELECT 10UF-M/50V		D040100087070S		
C953D	00D 963 0234 205	C,ELECT 10UF-M/50V		D040100087070S		
C954D	nsp	C,CERAMIC 0.1UF-Z/50V		D011104597160S		
C955D	nsp	C,CERAMIC 0.1UF-Z/50V		D011104597160S		
C956D	nsp	C,CERAMIC 22PF-J/50V		D010220167160S		
C957D	nsp	C,CERAMIC 0.1UF-Z/50V		D011104597160S		
C959D	nsp	C,CERAMIC 22PF-J/50V		D010220167160S		
BC801	00D 254 4666 005	CE04W0H105ZC(FG)		D041105090010S		
OTHERS PARTS GROUP						
BD802-809	nsp	COIL,BEAD MB-160808		D340160800060S		
BD809D	nsp	COIL,BEAD MB-160808		D340160800060S		
BD810-817	nsp	COIL,BEAD MB-160808		D340160800060S		
CN106	nsp	CN.WAFER 5P		L101100030510S		
CN108	00D 963 0085 302	CN.WAFER 17P		L101100031710S		
CP01	nsp	CN.WAFER 16P		L101100041610S		
CP301A	00D 963 0367 400	CN.FPC 35P		L131524923520S		
CP701	nsp	CN.WAFER 19P		L101100041910S		
CP702	nsp	CN.WAFER 15P		L100912150010S		
CP703	nsp	CN.WAFER 8P		L101100040810S		
CP801	00D 963 0149 303	CN.FPC 15P		L131111500010S		
CP802	nsp	CN.WAFER 16P		L100912160010S		
CP803	nsp	CN.WAFER 16P		L101100041610S		
CP804	nsp	CN.WAFER 15P		L100912150010S		
CP805	nsp	CN.WAFER 08P		L100912080010S		
CP1001	nsp	CN.WAFER 08P		L101100040810S		
CP1002	nsp	CN.WAFER 9P		L101100040910S		
JACK801	00D 963 0217 905	TER,RCA 2PIN		G601206A0200YS		
JACK802	00D 963 0294 601	JACK,D3.5 EARPHONE		G40100350000YS		
L801D	nsp	COIL INDUCTOR 4.7UH		D3304R7000150S		

Ref. No.	Part No.	Part Name	Remarks		Q'ty	New
L802D	nsp	COIL INDUCTOR 4.7UH		D3304R7000150S		
L803D	nsp	COIL INDUCTOR 4.7UH		D3304R7000150S		
L805D	nsp	COIL INDUCTOR 4.7UH		D3304R7000150S		
L806D	nsp	COIL INDUCTOR 22UH		D330220010520S		
L807D	nsp	COIL INDUCTOR 22UH		D330220010520S		
TP803	nsp	CN.WAFER 8P		L101220080000S		
TP804	nsp	CN.WAFER 4P		L101220040000S		
X801	00D 963 0217 701	RESONATOR,CERAMIC ZTT12.00MT		E830120000060S		
OPT801D	00D 963 0237 503	MODULE JSR1165-C		E100116500040S		
OPT802D	00D 963 0237 503	MODULE JSR1165-C		E100116500040S		
	nsp	CN,WIRE 110MM/1P		L000111010010S		

HDMI P.W.B. UNIT ASS'Y

Ref. No.	Part No.	Part Name	Remarks	Q'ty	New
SEMICONDUCTORS GROUP					
IC01	nsp	SII9185CTU		00D2623721007	
IC03	nsp	IC SE1117-1.8		J126111718010S	
IC04	nsp	IC F2621E-01-PR		J080260200040S	
IC05	nsp	IC SE1117-33-PF		J126111733020S	
IC06	nsp	IC AK4385		J042438500010S	
IC07	nsp	SN74LV08APW-EL2 +REF		00D2622517908	
IC08,09	nsp	SN74AHCT08PW-EL2 +C		00D2622813903	
IC10	nsp	IC NJM2068M		J121206800020S	
IC11	nsp	IC KIA1117PI50		J126111750050S	
IC12	nsp	IC BU4094BCF-E2		J040140940030S	
IC801	nsp	ADSP21367KSZ1A1136		00D2623709016	
IC802	nsp	W9864G2GH-7		00D2623746008	
IC803	nsp	IC EN29LV160T-70TCP		J005291600010S	
IC807	nsp	LC89057W-VF4A		00D2623449004	
IC808	nsp	ADAU1328BSTZ1136		00D2623645015	
IC809-811	nsp	IC SN74LVC244APWR		J040742440230S	
IC812	nsp	IC SN74HCT244PWR		J040742440220S	
IC814,815	nsp	IC SN74HCT00PWR		J040740000210S	
IC816	nsp	74LVX157MTC +C		00D2622870904	
IC823	nsp	IC KIA7805API		J126780500110S	
IC825,826	nsp	IC SN74LVC74APWR		J040747400200S	
IC832	nsp	IC SE1117-33-PF		J126111733020S	
Q01,02	nsp	TR KRC102S		J522010200210S	
Q03,04	nsp	TR KRC104S		J522104S00210S	
Q05	nsp	TR KRA102S		J520010200210S	
Q06	nsp	TR KTC3875S		J522038750210S	
Q07	nsp	TR KRC104S		J522104S00210S	
Q08	nsp	TR KRC102S		J522010200210S	
Q09	nsp	TR KRA104S		J520010400210S	
Q10,11	nsp	TR KRC102S		J522010200210S	
Q12,13	nsp	TR KRA102S		J520010200210S	
Q14-17	nsp	TR KTC2875B(MB)		J5222875B0010S	
Q810D	nsp	TR KRC102S		J522010200210S	
Q811D	nsp	TR KRA102S		J520010200210S	
Q814D	nsp	TR KRA102S		J520010200210S	
D01-36	nsp	D,ESD IMSA-6802-01A		K067680200010S	
D37-44	nsp	D,SWITCHING KDS4148U		K005041480030S	
RESISTORS GROUP					
R41,42	nsp	COIL,BEAD MB-160808		D340160800060S	
R62	nsp	COIL,BEAD MB-160808		D340160800060S	
CAPACITORS GROUP					
C01	nsp	C,CERAMIC 1000PF-K/50V		D011102777160S	
C02-05	nsp	C,CERAMIC 0.1UF-K/50V		D011104577162S	
C06,07	nsp	C,CERAMIC 1000PF-K/50V		D011102777160S	
C08-14	nsp	C,CERAMIC 0.1UF-K/50V		D011104577162S	
C15-17	nsp	C,CERAMIC 1000PF-K/50V		D011102777160S	
C18,19	nsp	C,CERAMIC 0.1UF-K/50V		D011104577162S	
C20	nsp	C,CERAMIC 1000PF-K/50V		D011102777160S	

Ref. No.	Part No.	Part Name	Remarks		Q'ty	New
C21	nsp	C,CERAMIC 100PF-J/50V		D010101167160S		
C22	nsp	C,CERAMIC 1000PF-K/50V		D011102777160S		
C23	nsp	C,CERAMIC 100PF-J/50V		D010101167160S		
C24,25	nsp	C,ELECT 10UF-MVG/16V		D050100083460S		
C26,27	nsp	C,CERAMIC 0.01UF-K/50V		D011103777160S		
C28H	nsp	C,ELECT 10UF-MVG/16V		D050100083460S		
C29	nsp	C,CERAMIC 0.1UF-K/50V		D011104577162S		
C29H	nsp	C,ELECT 10UF-MVG/16V		D050100083460S		
C30	nsp	C,CERAMIC 0.1UF-K/50V		D011104577162S		
C30H	nsp	C,ELECT 10UF-MVG/16V		D050100083460S		
C31,32	nsp	C,CERAMIC 0.1UF-K/50V		D011104577162S		
C33-36	nsp	C,CERAMIC 20PF-J/50V		D010200167160S		
C37-39	nsp	C,CERAMIC 0.1UF-K/50V		D011104577162S		
C40	nsp	C,ELECT 22UF-MV/6.3V		D050220081450S		
C41	nsp	C,CERAMIC 0.1UF-K/50V		D011104577162S		
C42,43	nsp	C,CERAMIC 5PF-C/50V		D010050107160S		
C44	nsp	C,CERAMIC 0.1UF-K/50V		D011104577162S		
C45	nsp	C,CERAMIC 1000PF-K/50V		D011102777160S		
C46	nsp	C,CERAMIC 4.7UF-K/10V		D011475572200S		
C47-50	nsp	C,CERAMIC 0.1UF-K/50V		D011104577162S		
C51	nsp	C,CERAMIC 1000PF-K/50V		D011102777160S		
C52	nsp	C,CERAMIC 0.1UF-K/50V		D011104577162S		
C53	nsp	C,ELECT 10UF-MVG/16V		D050100083460S		
C54	nsp	C,CERAMIC 0.1UF-K/50V		D011104577162S		
C55	nsp	C,CERAMIC 4.7UF-K/10V		D011475572200S		
C56,57	nsp	C,CERAMIC 1000PF-K/50V		D011102777160S		
C58	nsp	C,CERAMIC 0.1UF-K/50V		D011104577162S		
C59	nsp	C,CERAMIC 1000PF-K/50V		D011102777160S		
C60	nsp	C,CERAMIC 0.1UF-K/50V		D011104577162S		
C61	nsp	C,CERAMIC 1000PF-K/50V		D011102777160S		
C62	nsp	C,CERAMIC 0.1UF-K/50V		D011104577162S		
C63-65	nsp	C,CERAMIC 100PF-J/50V		D010101167160S		
C66	nsp	C,CERAMIC 0.01UF-K/50V		D011103777160S		
C68	nsp	C,ELECT 0.1UF-MVG/50V		D050R10080010S		
C69,70	nsp	C,CERAMIC 0.1UF-K/50V		D011104577162S		
C71,72	nsp	C,ELECT 22UF-MV/6.3V		D050220081450S		
C73,74	nsp	C,ELECT 10UF-MVG/16V		D050100083460S		
C75	nsp	C,CERAMIC 560PF-J/50V		D010561167160S		
C76	nsp	C,CERAMIC 1800PF-K/50V		D011182777160S		
C77,78	nsp	C,CERAMIC 560PF-J/50V		D010561167160S		
C79	nsp	C,CERAMIC 1800PF-K/50V		D011182777160S		
C80	nsp	C,CERAMIC 560PF-J/50V		D010561167160S		
C82	nsp	C,CERAMIC 1000PF-K/50V		D011102777160S		
C831D	nsp	C,CERAMIC 0.1UF-K/50V		D011104577162S		
C832D	nsp	C,CERAMIC 1000PF-K/50V		D011102177101S		
C833D	nsp	C,CERAMIC 100PF-J/50V		D011101167101S		
C834D	nsp	C,CERAMIC 100PF-J/50V		D011101167101S		
C835D	nsp	C,CERAMIC 0.01UF-K/50V		D011103177101S		
C836D	nsp	C,CERAMIC 0.01UF-K/50V		D011103177101S		
C837D	nsp	C,CERAMIC 100PF-J/50V		D011101167101S		
C838D	nsp	C,CERAMIC 100PF-J/50V		D011101167101S		
C839D	nsp	C,CERAMIC 100PF-J/50V		D011101167101S		
C840D	nsp	C,CERAMIC 100PF-J/50V		D011101167101S		
C841D	nsp	C,CERAMIC 100PF-J/50V		D011101167101S		
C842D	nsp	C,CERAMIC 100PF-J/50V		D011101167101S		
C843D	nsp	C,CERAMIC 100PF-J/50V		D011101167101S		

Ref. No.	Part No.	Part Name	Remarks		Q'ty	New
C844D	nsp	C,CERAMIC 100PF-J/50V		D011101167101S		
C845D	nsp	C,CERAMIC 0.1UF-K/50V		D011104177101S		
C846D	nsp	C,CERAMIC 1000PF-K/50V		D011102177101S		
C847D	nsp	C,CERAMIC 1000PF-K/50V		D011102177101S		
C848D	nsp	C,CERAMIC 1000PF-K/50V		D011102177101S		
C849D	nsp	C,CERAMIC 1000PF-K/50V		D011102177101S		
C850D	nsp	C,CERAMIC 1000PF-K/50V		D011102177101S		
C851D	nsp	C,CERAMIC 1000PF-K/50V		D011102177101S		
C852D	nsp	C,CERAMIC 1000PF-K/50V		D011102177101S		
C853D	nsp	C,CERAMIC 1000PF-K/50V		D011102177101S		
C854D	nsp	C,CERAMIC 0.1UF-K/50V		D011104177101S		
C855D	nsp	C,CERAMIC 0.1UF-K/50V		D011104177101S		
C856D	nsp	C,CERAMIC 0.1UF-K/50V		D011104177101S		
C857D	nsp	C,CERAMIC 0.1UF-K/50V		D011104177101S		
C858D	nsp	C,CERAMIC 0.1UF-K/50V		D011104177101S		
C859D	nsp	C,CERAMIC 0.1UF-K/50V		D011104177101S		
C860D	nsp	C,CERAMIC 0.1UF-K/50V		D011104177101S		
C861D	nsp	C,CERAMIC 0.1UF-K/50V		D011104177101S		
C862D	nsp	C,CERAMIC 0.01UF-K/50V		D011103177101S		
C863D	nsp	C,CERAMIC 100PF-J/50V		D011101167101S		
C864D	nsp	C,CERAMIC 4.7UF-K/10V		D011475572200S		
C865D	nsp	C,CERAMIC 5PF-C/50V		D010050107160S		
C866D	nsp	C,CERAMIC 5PF-C/50V		D010050107160S		
C871D	nsp	C,CERAMIC 0.01UF-K/50V		D011103177101S		
C873D	nsp	C,CERAMIC 0.01UF-K/50V		D011103177101S		
C875D	nsp	C,CERAMIC 4.7UF-K/10V		D011475572200S		
C876D	nsp	C,CERAMIC 0.01UF-K/50V		D011103177101S		
C877D	nsp	C,CERAMIC 0.1UF-K/50V		D011104177101S		
C878D	nsp	C,CERAMIC 0.1UF-K/50V		D011104177101S		
C879D	nsp	C,CERAMIC 0.1UF-K/50V		D011104177101S		
C880D	nsp	C,CERAMIC 0.01UF-K/50V		D011103177101S		
C881D	nsp	C,CERAMIC 0.01UF-K/50V		D011103177101S		
C882D	nsp	C,CERAMIC 6PF-D/50V		D010060117160S		
C883D	nsp	C,CERAMIC 6PF-D/50V		D010060117160S		
C884D	nsp	C,CERAMIC 0.1UF-K/50V		D011104577162S		
C885D	nsp	C,CERAMIC 0.022UF-Z/50V		D011223597160S		
C886D	nsp	C,CERAMIC 0.1UF-K/50V		D011104177101S		
C887D	nsp	C,FILM 0.12UF-J/63V		D020124078060S		
C888D	nsp	C,CERAMIC 0.01UF-K/50V		D011103177101S		
C889D	nsp	C,CERAMIC 100PF-J/50V		D011101167101S		
C890D	nsp	C,CERAMIC 0.01UF-K/50V		D011103177101S		
C891D	nsp	C,CERAMIC 0.01UF-K/50V		D011103177101S		
C892D	nsp	C,CERAMIC 4.7UF-K/10V		D011475572200S		
C893D	nsp	C,CERAMIC 0.1UF-K/50V		D011104177101S		
C895D	nsp	C,CERAMIC 0.1UF-K/50V		D011104177101S		
C896D	nsp	C,CERAMIC 0.01UF-K/50V		D011103177101S		
C897D	nsp	C,CERAMIC 0.1UF-K/50V		D011104177101S		
C898D	nsp	C,CERAMIC 0.1UF-K/50V		D011104177101S		
C899D	nsp	C,CERAMIC 100PF-J/50V		D011101167101S		
C900D	nsp	C,CERAMIC 4.7UF-K/10V		D011475572200S		
C901D	nsp	C,ELECT 100UF-MVG/6.3V		D050101081650S		
C902D	nsp	C,CERAMIC 0.1UF-K/50V		D011104177101S		
C903D	nsp	C,CERAMIC 0.1UF-K/50V		D011104177101S		
C904D	nsp	C,CERAMIC 5600PF-K/50V		D011562777160S		
C905D	nsp	C,CERAMIC 390PF-J/50V		D010391167160S		
C906D	nsp	C,CERAMIC 0.1UF-K/50V		D011104177101S		

Ref. No.	Part No.	Part Name	Remarks		Q'ty	New
C907D	nsp	C,CERAMIC 0.1UF-K/50V		D011104177101S		
C908D	nsp	C,ELECT 47UF-MVG/6.3V		D050470081460S		
C909D	nsp	C,CERAMIC 0.1UF-K/50V		D011104177101S		
C910D	nsp	C,ELECT 10UF-MVG/16V		D050100083460S		
C911D	nsp	C,CERAMIC 0.01UF-K/50V		D011103177101S		
C913D	nsp	C,ELECT 10UF-MVG/16V		D050100083460S		
C914D	nsp	C,CERAMIC 0.01UF-K/50V		D011103177101S		
C915D	nsp	C,ELECT 10UF-MVG/16V		D050100083460S		
OTHERS PARTS GROUP						
BD801	nsp	COIL,BEAD MB-160808		D340160800060S		
BD807D	nsp	COIL,BEAD MB-160808		D340160800060S		
BD808D-03	nsp	COIL,BEAD MB-160808		D340160800060S		
CB06	nsp	COIL,BEAD MB-160808		D340160800060S		
CN01	nsp	CN.WAFER 16P		L101100031610S		
CN802	nsp	CN.HOUSING 16P		L120912160010S		
CN803	nsp	CN.WAFER 16P		L101100031610S		
CN804	nsp	CN.HOUSING 15P		L120912150010S		
CN805	nsp	CN.HOUSING 08P		L120912080010S		
CP201	nsp	CN.WAFER 9P		L101220090000S		
CP404	nsp	CN.WAFER 4P		L101220040000S		
CP405	nsp	CN.WAFER 5P		L101220050000S		
CP904	nsp	CN.WAFER 6P		L101220060010S		
J806	nsp	R,CHIP THICK 0-J,1/16W		C20000006M101S		
JACK01-03	00D 963 0388 504	19PIN HDMI CONNECTOR		L109100190020S		
JACK04	nsp	CAM-D96 4PIN SMALL COCNNETOR		L109040000020S		
TP801	nsp	CN.WAFER 13P		L101530141310S		
X01	nsp	FCX-02(45.1584MHz)		00D3991055912		
X803D	nsp	FCX-03(16.660MHz)		00D3991091905		
X804D	nsp	FCX-03(24.576MHz)		00D3991053901		

VIDEO P.W.B. UNIT ASS'Y

Ref. No.	Part No.	Part Name	Remarks	Q'ty	New
SEMICONDUCTORS GROUP					
IC1301	00D 960 0175 200	IC BA7625		J171762500000S	
IC1302,1303	00D 963 0083 304	IC BA7626		J171762600000S	
IC1304	00D 960 0239 104	IC KIA7806API		J126780600130S	
IC1305-1307	00D 963 0148 401	IC LA7956		J171795600010S	
Q1301-1303	00D 960 0005 105	TR KTA1266Y		J5001266Y0050S	
Q1304,1305	00D 960 0005 202	TR KTC3198Y		J5023198Y0000S	
Q1306-1309	00D 963 0121 208	TR KRC107M		J6020107M0010S	
Q1310-1313	00D 960 0005 202	TR KTC3198Y		J5023198Y0000S	
Q1314-1317	00D 963 0121 208	TR KRC107M		J6020107M0010S	
D1301	00D 963 0355 401	D,SWITCHING KDS4148U		K005041480030S	
D1302-1305	00D 276 0401 905	D,SWITCHING 1SS133T		K000013300520S	
D1306,1307	00D 963 0355 401	D,SWITCHING KDS4148U		K005041480030S	
CAPACITORS GROUP					
C1301-1309	00D 960 9010 010	C,ELECT 4.7UF-M/50V		D0404R7087250S	
C1310	00D 963 9005 969	C,ELECT 4700UF-M/6.3V		D040472081000S	
C1311,1312	00D 960 0298 802	C,ELECT 470UF-M/6.3V		D040471081070S	
C1313-1315	00D 963 0311 607	C,ELECT 100UF-M/10V (Pb Free)		D040101082090S	
C1316-1321	00D 963 0293 602	C,ELECT 1UF-M/50V(Pb Free)		D040010087150S	
C1322	nsp	C,CERAMIC 0.022UF-K/25V		D011223777160S	
C1323	00D 963 0311 607	C,ELECT 100UF-M/10V (Pb Free)		D040101082090S	
C1324	nsp	C,CERAMIC 0.022UF-K/25V		D011223777160S	
C1326	nsp	C,CERAMIC 0.022UF-K/25V		D011223777160S	
C1328	00D 963 0234 205	C,ELECT 10UF-M/50V		D040100087070S	
C1329	00D 963 0234 506	C,ELECT 47UF-M/50V (Pb Free)		D040470087070S	
C1330	00D 963 0234 205	C,ELECT 10UF-M/50V		D040100087070S	
C1331-1339	00D 963 9005 862	C,ELECT 47UF-M/16V		D040470083080S	
C1340-1345	00D 963 9005 901	C,ELECT 470UF-M/10V		D040471082060S	
C1347	nsp	C,CERAMIC 0.047UF-Z/50V		D011473597160S	
C1348	00D 960 9009 924	C,ELECT 100UF-M/16V		D040101083070S	
C1349,1350	nsp	C,CERAMIC 0.047UF-Z/50V		D011473597160S	
C1351,1352	00D 963 0293 602	C,ELECT 1UF-M/50V(Pb Free)		D040010087150S	
OTHERS PARTS GROUP					
CN406	nsp	CN,WIRE 300MM/3P		L000301030060S	
CN1301	nsp	CN.WAFER 5P		L101220050010S	
CN1303	nsp	CN.WAFER 8P		L101100030810S	
CP1302	nsp	CN.WAFER 9P		L101100030910S	
JACK1301	00D 963 0218 001	TER,RCA 2PIN		G60122001000YS	
JACK1302	00D 963 0218 108	TER,RCA 3PIN		G60630401000YS	
JACK1303,1304	00D 963 0367 709	TER,RCA 6PIN		G603610D0032YS	
	nsp	HEAT SINK		2120044338010S	
	nsp	SCREW,TAP TITE +2S 3*8 B-TYPE ZNW/BH		B020030081B10S	

HDMI_PWR P.W.B. UNIT ASS'Y

Ref. No.	Part No.	Part Name	Remarks	Q'ty	New
SEMICONDUCTORS GROUP					
IC401H1	00D 963 0366 500	IC KIA1117PI33		J126111733050S	
CAPACITORS GROUP					
C405H1	00D 963 0234 205	C,ELECT 10UF-M/50V		D040100087070S	
C406H1	00D 963 0233 303	C,CERAMIC 0.01UF-M/16V		D005103773530S	
OTHERS PARTS GROUP					
CN404	nsp	CN,WIRE 300MM/4P		L000301040110S	
CP513	nsp	CN.WAFER 3P ANGLE		L102526803010S	

PARTS LIST OF P.W.B. UNIT



AVR-488 E3 MODEL

* 本表に "nsp" と記載されている部品は供給できません。

* Parts for which "nsp" is indicated on this table cannot be supplied.

* 本表に記載されている部品は、補修用部品のため製品に使用している部品とは一部、形状、寸法などが異なる場合があります。

* The parts listed below are for maintenance only, might differ from the parts used in the unit in appearances or dimensions.

MAIN P.W.B. UNIT ASS'Y

Ref. No.	Part No.	Part Name	Remarks	Q'ty	New
SEMICONDUCTORS GROUP					
IC110,111	00D 963 0218 807	IC BU4094BCF-E2		J040140940030S	
Q101	00D 960 0196 302	TR KTA1268BL		J5001268B0050S	
Q102-104	00D 960 0196 700	TR KTC3200BL		J5023200B0050S	
Q104C	00D 960 0196 506	TR KSC1845F		J5021845F0000S	
Q104FL	00D 960 0196 506	TR KSC1845F		J5021845F0000S	
Q104FR	00D 960 0196 506	TR KSC1845F		J5021845F0000S	
Q104SL	00D 960 0196 506	TR KSC1845F		J5021845F0000S	
Q104SR	00D 960 0196 506	TR KSC1845F		J5021845F0000S	
Q105	00D 960 0196 700	TR KTC3200BL		J5023200B0050S	
Q105C	00D 960 0196 603	TR KTC2874B		J502287400010S	
Q105FL	00D 960 0196 603	TR KTC2874B		J502287400010S	
Q105FR	00D 960 0196 603	TR KTC2874B		J502287400010S	
Q105SL	00D 960 0196 603	TR KTC2874B		J502287400010S	
Q105SR	00D 960 0196 603	TR KTC2874B		J502287400010S	
Q106	00D 960 0196 700	TR KTC3200BL		J5023200B0050S	
Q106C	00D 960 0196 205	TR KSA992F		J5000992F0050S	
Q106FL	00D 960 0196 205	TR KSA992F		J5000992F0050S	
Q106FR	00D 960 0196 205	TR KSA992F		J5000992F0050S	
Q106SL	00D 960 0196 205	TR KSA992F		J5000992F0050S	
Q106SR	00D 960 0196 205	TR KSA992F		J5000992F0050S	
Q107	00D 960 0196 700	TR KTC3200BL		J5023200B0050S	
Q107C	00D 960 0196 205	TR KSA992F		J5000992F0050S	
Q107FL	00D 960 0196 205	TR KSA992F		J5000992F0050S	
Q107FR	00D 960 0196 205	TR KSA992F		J5000992F0050S	
Q107SL	00D 960 0196 205	TR KSA992F		J5000992F0050S	
Q107SR	00D 960 0196 205	TR KSA992F		J5000992F0050S	
Q108	00D 960 0196 700	TR KTC3200BL		J5023200B0050S	
Q108C	00D 960 0196 506	TR KSC1845F		J5021845F0000S	
Q108FL	00D 960 0196 506	TR KSC1845F		J5021845F0000S	
Q108FR	00D 960 0196 506	TR KSC1845F		J5021845F0000S	
Q108SL	00D 960 0196 506	TR KSC1845F		J5021845F0000S	
Q108SR	00D 960 0196 506	TR KSC1845F		J5021845F0000S	
Q109,110	00D 960 0196 700	TR KTC3200BL		J5023200B0050S	
Q111	00D 960 0196 302	TR KTA1268BL		J5001268B0050S	
Q130	00D 960 0196 302	TR KTA1268BL		J5001268B0050S	
Q131,132	00D 963 0219 602	TR KRC106M		J6020106M0010S	
Q133-135	00D 960 0097 207	TR KRA102M		J6002202M0010S	
Q137	00D 960 0097 207	TR KRA102M		J6002202M0010S	
Q141SW	00D 963 0044 301	TR KTC2875B(MB)		J5222875B0010S	
Q142	00D 960 0196 700	TR KTC3200BL		J5023200B0050S	
Q142SW	00D 963 0044 301	TR KTC2875B(MB)		J5222875B0010S	
Q143,144	00D 960 0196 302	TR KTA1268BL		J5001268B0050S	
Q145	00D 960 0196 700	TR KTC3200BL		J5023200B0050S	
Q146,147	00D 960 0196 302	TR KTA1268BL		J5001268B0050S	
Q151	00D 960 0196 302	TR KTA1268BL		J5001268B0050S	
Q156	00D 960 0097 304	TR KRC102M		J6020102M0010S	
Q165	00D 960 0196 700	TR KTC3200BL		J5023200B0050S	

Ref. No.	Part No.	Part Name	Remarks		Q'ty	New
Q166-171	00D 960 0196 302	TR KTA1268BL		J5001268B0050S		
Q541	00D 963 0121 208	TR KRC107M		J6020107M0010S		
D101C	00D 963 0355 401	D,SWITCHING KDS4148U		K005041480030S		
D101FL	00D 963 0355 401	D,SWITCHING KDS4148U		K005041480030S		
D101FR	00D 963 0355 401	D,SWITCHING KDS4148U		K005041480030S		
D101SL	00D 963 0355 401	D,SWITCHING KDS4148U		K005041480030S		
D101SR	00D 963 0355 401	D,SWITCHING KDS4148U		K005041480030S		
D102C	00D 963 0355 401	D,SWITCHING KDS4148U		K005041480030S		
D102FL	00D 963 0355 401	D,SWITCHING KDS4148U		K005041480030S		
D102FR	00D 963 0355 401	D,SWITCHING KDS4148U		K005041480030S		
D102SL	00D 963 0355 401	D,SWITCHING KDS4148U		K005041480030S		
D102SR	00D 963 0355 401	D,SWITCHING KDS4148U		K005041480030S		
D105C	00D 963 0020 309	D,SWITCHING 1SS133T		K000013300520S		
D105FL	00D 963 0020 309	D,SWITCHING 1SS133T		K000013300520S		
D105FR	00D 963 0020 309	D,SWITCHING 1SS133T		K000013300520S		
D105SL	00D 963 0020 309	D,SWITCHING 1SS133T		K000013300520S		
D105SR	00D 963 0020 309	D,SWITCHING 1SS133T		K000013300520S		
D106,107	00D 963 0355 401	D,SWITCHING KDS4148U		K005041480030S		
D114,115	00D 960 0197 107	D,RECTIFIER BRIDGE KBPC604		K047604000020S		
D139	00D 963 0020 309	D,SWITCHING 1SS133T		K000013300520S		
D140,141	00D 963 0328 409	D,SWITCHING 1N4007		K000400700010S		
D142	00D 963 0355 401	D,SWITCHING KDS4148U		K005041480030S		
D147-152	00D 963 0020 309	D,SWITCHING 1SS133T		K000013300520S		
D153	00D 963 0355 401	D,SWITCHING KDS4148U		K005041480030S		
D154-157	00D 963 0020 309	D,SWITCHING 1SS133T		K000013300520S		
D541	00D 963 0355 401	D,SWITCHING KDS4148U		K005041480030S		
ZD101	00D 963 0058 601	D,ZENER MTZJ12B		K06012R044520S		
ZD101C	00D 963 0367 008	D,ZENER 0.2W 3.3V UDZ		K06603R34P400S		
ZD101FL	00D 963 0367 008	D,ZENER 0.2W 3.3V UDZ		K06603R34P400S		
ZD101FR	00D 963 0367 008	D,ZENER 0.2W 3.3V UDZ		K06603R34P400S		
ZD101SL	00D 963 0367 008	D,ZENER 0.2W 3.3V UDZ		K06603R34P400S		
ZD101SR	00D 963 0367 008	D,ZENER 0.2W 3.3V UDZ		K06603R34P400S		
ZD102C	00D 963 0367 008	D,ZENER 0.2W 3.3V UDZ		K06603R04P400S		
ZD102FL	00D 963 0367 008	D,ZENER 0.2W 3.3V UDZ		K06603R04P400S		
ZD102FR	00D 963 0367 008	D,ZENER 0.2W 3.3V UDZ		K06603R04P400S		
ZD102SL	00D 963 0367 008	D,ZENER 0.2W 3.3V UDZ		K06603R04P400S		
ZD102SR	00D 963 0367 008	D,ZENER 0.2W 3.3V UDZ		K06603R04P400S		
ZD105	00D 960 0095 500	D,ZENER MTZJ5.1B		K06005R144520S		
RESISTORS GROUP						
R101	00D 963 0337 801	R,METAL FILM 100-J,2W		C060010166520S		
R103	00D 963 9005 639	R,METAL FILM 100-J,1W		C060010165060S		
R104	00D 963 0215 907	R,METAL FILM 4.7-J,1W		C0604R7065050S		
R104C	00D 963 9006 285	R,FIXED 1WJ-5.6K		N113135656220S		
R104FL	00D 963 9006 285	R,FIXED 1WJ-5.6K		N113135656220S		
R104FR	00D 963 9006 285	R,FIXED 1WJ-5.6K		N113135656220S		
R104SL	00D 963 9006 285	R,FIXED 1WJ-5.6K		N113135656220S		
R104SR	00D 963 9006 285	R,FIXED 1WJ-5.6K		N113135656220S		
R105	00D 963 0232 906	R,METAL FILM 47K-F,1/4W		C060047343530S		
R105C	00D 963 9006 285	R,FIXED 1WJ-5.6K		N113135656220S		
R105FL	00D 963 9006 285	R,FIXED 1WJ-5.6K		N113135656220S		
R105FR	00D 963 9006 285	R,FIXED 1WJ-5.6K		N113135656220S		
R105SL	00D 963 9006 285	R,FIXED 1WJ-5.6K		N113135656220S		

Ref. No.	Part No.	Part Name	Remarks		Q'ty	New
R105SR	00D 963 9006 285	R,FIXED 1WJ-5.6K		N113135656220S		
R106C	00D 963 0215 907	R,METAL FILM 4.7-J,1W		C0604R7065050S		
R106FL	00D 963 0215 907	R,METAL FILM 4.7-J,1W		C0604R7065050S		
R106FR	00D 963 0215 907	R,METAL FILM 4.7-J,1W		C0604R7065050S		
R106SL	00D 963 0215 907	R,METAL FILM 4.7-J,1W		C0604R7065050S		
R106SR	00D 963 0215 907	R,METAL FILM 4.7-J,1W		C0604R7065050S		
R107C	00D 963 0215 907	R,METAL FILM 4.7-J,1W		C0604R7065050S		
R107FL	00D 963 0215 907	R,METAL FILM 4.7-J,1W		C0604R7065050S		
R107FR	00D 963 0215 907	R,METAL FILM 4.7-J,1W		C0604R7065050S		
R107SL	00D 963 0215 907	R,METAL FILM 4.7-J,1W		C0604R7065050S		
R107SR	00D 963 0215 907	R,METAL FILM 4.7-J,1W		C0604R7065050S		
R108C	00D 963 0345 903	R,FIXED 2WJ-0.47		N113136647820S		
R108FL	00D 963 0345 903	R,FIXED 2WJ-0.47		N113136647820S		
R108FR	00D 963 0345 903	R,FIXED 2WJ-0.47		N113136647820S		
R108SL	00D 963 0345 903	R,FIXED 2WJ-0.47		N113136647820S		
R108SR	00D 963 0345 903	R,FIXED 2WJ-0.47		N113136647820S		
R109C	00D 963 0345 903	R,FIXED 2WJ-0.47		N113136647820S		
R109FL	00D 963 0345 903	R,FIXED 2WJ-0.47		N113136647820S		
R109FR	00D 963 0345 903	R,FIXED 2WJ-0.47		N113136647820S		
R109SL	00D 963 0345 903	R,FIXED 2WJ-0.47		N113136647820S		
R109SR	00D 963 0345 903	R,FIXED 2WJ-0.47		N113136647820S		
R110C	00D 963 0345 903	R,FIXED 2WJ-0.47		N113136647820S		
R110FL	00D 963 0345 903	R,FIXED 2WJ-0.47		N113136647820S		
R110FR	00D 963 0345 903	R,FIXED 2WJ-0.47		N113136647820S		
R110SL	00D 963 0345 903	R,FIXED 2WJ-0.47		N113136647820S		
R110SR	00D 963 0345 903	R,FIXED 2WJ-0.47		N113136647820S		
R111C	00D 963 0345 903	R,FIXED 2WJ-0.47		N113136647820S		
R111FL	00D 963 0345 903	R,FIXED 2WJ-0.47		N113136647820S		
R111FR	00D 963 0345 903	R,FIXED 2WJ-0.47		N113136647820S		
R111SL	00D 963 0345 903	R,FIXED 2WJ-0.47		N113136647820S		
R111SR	00D 963 0345 903	R,FIXED 2WJ-0.47		N113136647820S		
R117,118	00D 963 0144 502	R,CEMENT 0.1-J 5W		C141R10069000S		
R118C	00D 963 9006 256	R,FIXED 1WJ-10		N113135610020S		
R118FL	00D 963 9006 256	R,FIXED 1WJ-10		N113135610020S		
R118FR	00D 963 9006 256	R,FIXED 1WJ-10		N113135610020S		
R118SL	00D 963 9006 256	R,FIXED 1WJ-10		N113135610020S		
R118SR	00D 963 9006 256	R,FIXED 1WJ-10		N113135610020S		
R119C	00D 963 9006 256	R,FIXED 1WJ-10		N113135610020S		
R119FL	00D 963 9006 256	R,FIXED 1WJ-10		N113135610020S		
R119FR	00D 963 9006 256	R,FIXED 1WJ-10		N113135610020S		
R119SL	00D 963 9006 256	R,FIXED 1WJ-10		N113135610020S		
R119SR	00D 963 9006 256	R,FIXED 1WJ-10		N113135610020S		
R127C	00D 963 9005 642	R,METAL FILM 1.2K-J,1W		C060012265050S		
R127FL	00D 963 9005 642	R,METAL FILM 1.2K-J,1W		C060012265050S		
R127FR	00D 963 9005 642	R,METAL FILM 1.2K-J,1W		C060012265050S		
R127SL	00D 963 9005 642	R,METAL FILM 1.2K-J,1W		C060012265050S		
R127SR	00D 963 9005 642	R,METAL FILM 1.2K-J,1W		C060012265050S		
R132C	00D 960 9010 719	R,METAL FILM 47-J,1W		C060047065060S		
R132FL	00D 960 9010 719	R,METAL FILM 47-J,1W		C060047065060S		
R132FR	00D 960 9010 719	R,METAL FILM 47-J,1W		C060047065060S		
R132SL	00D 960 9010 719	R,METAL FILM 47-J,1W		C060047065060S		
R132SR	00D 960 9010 719	R,METAL FILM 47-J,1W		C060047065060S		
R147-149	00D 963 9005 642	R,METAL FILM 1.2K-J,1W		C060012265050S		
VR101C	00D 960 0221 109	VR,SEMI CARBON EVN-DJAA03B		C541102115000S		
VR101FL	00D 960 0221 109	VR,SEMI CARBON EVN-DJAA03B		C541102115000S		

Ref. No.	Part No.	Part Name	Remarks		Q'ty	New
VR101FR	00D 960 0221 109	VR,SEMI CARBON EVN-DJAA03B		C541102115000S		
VR101SL	00D 960 0221 109	VR,SEMI CARBON EVN-DJAA03B		C541102115000S		
VR101SR	00D 960 0221 109	VR,SEMI CARBON EVN-DJAA03B		C541102115000S		
CAPACITORS GROUP						
C101	00D 963 9005 804	C,ELECT 100UF-M/25V		D040101084060S		
C101C	00D 963 0234 506	C,ELECT 47UF-M/50V (Pb Free)		D040470087070S		
C101FL	00D 963 0234 506	C,ELECT 47UF-M/50V (Pb Free)		D040470087070S		
C101FR	00D 963 0234 506	C,ELECT 47UF-M/50V (Pb Free)		D040470087070S		
C101SL	00D 963 0234 506	C,ELECT 47UF-M/50V (Pb Free)		D040470087070S		
C101SR	00D 963 0234 506	C,ELECT 47UF-M/50V (Pb Free)		D040470087070S		
C102	00D 963 0224 503	C,ELECT 22UF-M/50V		D040220087060S		
C102C	00D 963 0234 205	C,ELECT 10UF-M/50V		D040100087070S		
C102FL	00D 960 9010 133	C,ELECT 220UF-M/35V		D040221085060S		
C102FR	00D 960 9010 133	C,ELECT 220UF-M/35V		D040221085060S		
C102SL	00D 963 0234 205	C,ELECT 10UF-M/50V		D040100087070S		
C102SR	00D 963 0234 205	C,ELECT 10UF-M/50V		D040100087070S		
C103	00D 963 9006 557	C,ELECT 220UF-M/6.3V		D040221081060S		
C103C	00D 963 9003 084	C,CERAMIC 100PF-K/500V		D00410106D050S		
C103FL	00D 963 9003 084	C,CERAMIC 100PF-K/500V		D00410106D050S		
C103FR	00D 963 9003 084	C,CERAMIC 100PF-K/500V		D00410106D050S		
C103SL	00D 963 9003 084	C,CERAMIC 100PF-K/500V		D00410106D050S		
C103SR	00D 963 9003 084	C,CERAMIC 100PF-K/500V		D00410106D050S		
C104	00D 963 9006 557	C,ELECT 220UF-M/6.3V		D040221081060S		
C104C	00D 963 9003 084	C,CERAMIC 100PF-K/500V		D00410106D050S		
C104FL	00D 963 9003 084	C,CERAMIC 100PF-K/500V		D00410106D050S		
C104FR	00D 963 9003 084	C,CERAMIC 100PF-K/500V		D00410106D050S		
C104SL	00D 963 9003 084	C,CERAMIC 100PF-K/500V		D00410106D050S		
C104SR	00D 963 9003 084	C,CERAMIC 100PF-K/500V		D00410106D050S		
C105	00D 963 9006 557	C,ELECT 220UF-M/6.3V		D040221081060S		
C105C	nsp	C,CERAMIC 0.022UF-Z/50V		D011223597160S		
C105FL	nsp	C,CERAMIC 0.022UF-Z/50V		D011223597160S		
C105FR	nsp	C,CERAMIC 0.022UF-Z/50V		D011223597160S		
C105SL	nsp	C,CERAMIC 0.022UF-Z/50V		D011223597160S		
C105SR	nsp	C,CERAMIC 0.022UF-Z/50V		D011223597160S		
C106	00D 963 0293 709	C,ELECT 100UF-M/10V		D040101082070S		
C107	nsp	C,CERAMIC 0.01UF-K/50V		D011103777160S		
C107C	00D 963 9003 097	C,FILM 0.1UF-K/250V		D02010407H080S		
C107FL	00D 963 9003 097	C,FILM 0.1UF-K/250V		D02010407H080S		
C107FR	00D 963 9003 097	C,FILM 0.1UF-K/250V		D02010407H080S		
C107SL	00D 963 9003 097	C,FILM 0.1UF-K/250V		D02010407H080S		
C107SR	00D 963 9003 097	C,FILM 0.1UF-K/250V		D02010407H080S		
C108	00D 963 0149 400	CAP.E.GENERIC 10000UF/63V		N211210388110S		
C108C	00D 963 9006 544	C,ELECT 22UF-M/25V		D040220084050S		
C108FL	00D 963 9006 544	C,ELECT 22UF-M/25V		D040220084050S		
C108FR	00D 963 9006 544	C,ELECT 22UF-M/25V		D040220084050S		
C108SL	00D 963 9006 544	C,ELECT 22UF-M/25V		D040220084050S		
C108SR	00D 963 9006 544	C,ELECT 22UF-M/25V		D040220084050S		
C109	00D 963 0149 400	CAP.E.GENERIC 10000UF/63V		N211210388110S		
C109C	00D 963 0234 205	C,ELECT 10UF-M/50V		D040100087070S		
C109FL	00D 963 0234 205	C,ELECT 10UF-M/50V		D040100087070S		
C109FR	00D 963 0234 205	C,ELECT 10UF-M/50V		D040100087070S		
C109SL	00D 963 0234 205	C,ELECT 10UF-M/50V		D040100087070S		
C109SR	00D 963 0234 205	C,ELECT 10UF-M/50V		D040100087070S		
C110	00D 963 9003 097	C,FILM 0.1UF-K/250V		D02010407H080S		

Ref. No.	Part No.	Part Name	Remarks		Q'ty	New
C110C	00D 963 0338 208	C,CERAMIC 470PF-K/500V		D00447127D050S		
C110FL	00D 963 0338 208	C,CERAMIC 470PF-K/500V		D00447127D050S		
C110FR	00D 963 0338 208	C,CERAMIC 470PF-K/500V		D00447127D050S		
C110SL	00D 963 0338 208	C,CERAMIC 470PF-K/500V		D00447127D050S		
C110SR	00D 963 0338 208	C,CERAMIC 470PF-K/500V		D00447127D050S		
C111	00D 963 9003 097	C,FILM 0.1UF-K/250V		D02010407H080S		
C111C	00D 963 0367 101	C,CERAMIC 220PF-J/500V		D00422106D05CS		
C111FL	00D 963 0367 101	C,CERAMIC 220PF-J/500V		D00422106D05CS		
C111FR	00D 963 0367 101	C,CERAMIC 220PF-J/500V		D00422106D05CS		
C111SL	00D 963 0367 101	C,CERAMIC 220PF-J/500V		D00422106D05CS		
C111SR	00D 963 0367 101	C,CERAMIC 220PF-J/500V		D00422106D05CS		
C112	00D 963 9003 097	C,FILM 0.1UF-K/250V		D02010407H080S		
C112C	00D 963 9003 194	C,FILM 0.0022UF-J/100V		D02022206C060S		
C112FL	00D 963 9003 194	C,FILM 0.0022UF-J/100V		D02022206C060S		
C112FR	00D 963 9003 194	C,FILM 0.0022UF-J/100V		D02022206C060S		
C112SL	00D 963 9003 194	C,FILM 0.0022UF-J/100V		D02022206C060S		
C112SR	00D 963 9003 194	C,FILM 0.0022UF-J/100V		D02022206C060S		
C113C	00D 963 0293 709	C,ELECT 100UF-M/10V		D040101082070S		
C113FL	00D 960 9010 133	C,ELECT 220UF-M/35V		D040221085060S		
C113FR	00D 960 9010 133	C,ELECT 220UF-M/35V		D040221085060S		
C113SL	00D 963 0293 709	C,ELECT 100UF-M/10V		D040101082070S		
C113SR	00D 963 0293 709	C,ELECT 100UF-M/10V		D040101082070S		
C114	00D 963 9003 097	C,FILM 0.1UF-K/250V		D02010407H080S		
C114C	00D 963 0216 100	C,CERAMIC 33PF-J/500V		D00033006D050S		
C114FL	00D 963 0216 100	C,CERAMIC 33PF-J/500V		D00033006D050S		
C114FR	00D 963 0216 100	C,CERAMIC 33PF-J/500V		D00033006D050S		
C114SL	00D 963 0216 100	C,CERAMIC 33PF-J/500V		D00033006D050S		
C114SR	00D 963 0216 100	C,CERAMIC 33PF-J/500V		D00033006D050S		
C115	00D 963 9003 097	C,FILM 0.1UF-K/250V		D02010407H080S		
C115SW	00D 963 9006 544	C,ELECT 22UF-M/25V		D040220084050S		
C117-120	nsp	C,CERAMIC 0.1UF-K/50V		D011104577160S		
C141SW1	00D 963 0234 205	C,ELECT 10UF-M/50V		D040100087070S		
C142SW1	nsp	C,CERAMIC 100PF-J/50V		D010101167160S		
C161	00D 963 0234 205	C,ELECT 10UF-M/50V		D040100087070S		
C162,163	nsp	C,CERAMIC 0.01UF-K/50V		D011103777160S		
C164	nsp	C,CERAMIC 100PF-J/50V		D010101167160S		
C166,167	nsp	C,CERAMIC 100PF-J/50V		D010101167160S		
C168-172	00D 963 0244 606	C,ELECT 0.1UF-M/50V (Pb Free)		D040R10087080S		
C177	nsp	C,CERAMIC 0.01UF-K/50V		D011103777160S		
C178,179	00D 960 9010 010	C,ELECT 4.7UF-M/50V		D0404R7087250S		
C180,181	nsp	C,CERAMIC 0.01UF-K/50V		D011103777160S		
C182	00D 963 0324 005	C,ELECT 100UF-M/100V		D04010108C240S		
C183	00D 963 0293 602	C,ELECT 1UF-M/50V (Pb Free)		D040010087150S		
C190	00D 960 9010 010	C,ELECT 4.7UF-M/50V		D0404R7087250S		
OTHERS PARTS GROUP						
BKT101	nsp	SHIELD PLATE GND		3070045526010S		
CN101	nsp	CN,WIRE 14P		L000111140010S		
CN103	nsp	CN,WIRE 7P		L000141070020S		
CN511	nsp	CN,WIRE 60MM/9P		L000600090020S		
CN704	nsp	CN,WIRE 15P		L000600110010S		
CP104	nsp	CN.WAFER 3CKT		L108353280360S		
CP106	nsp	CN.WAFER 5P		L101100040510S		

Ref. No.	Part No.	Part Name	Remarks		Q'ty	New
CP107	nsp	CN.WAFER 3P		L102526700300S		
CP108	nsp	CN.WAFER 17P		L101100041710S		
CP541	nsp	CN.WAFER 3P		L101220030000S		
GND101	nsp	TERMINAL EARTH		3790040886000S		
JACK222	00D 963 0146 005	TER,RCA 1PIN		G600107A0000YS		
L101C	00D 963 0049 005	COIL INDUCTOR 0.5UH		D330R50000000S		
L101FL	00D 963 0049 005	COIL INDUCTOR 0.5UH		D330R50000000S		
L101FR	00D 963 0049 005	COIL INDUCTOR 0.5UH		D330R50000000S		
L101SL	00D 963 0049 005	COIL INDUCTOR 0.5UH		D330R50000000S		
L101SR	00D 963 0049 005	COIL INDUCTOR 0.5UH		D330R50000000S		
RLY541	00D 963 0218 506	RELAY BC3-24 24V 2A		G680240202040S		
TP101-105	nsp	CN.WAFER 3P		L101530140310S		
JP108	00D 963 0223 009	R,THICK 0-J,1/16W		C20000006M160S		
JP350-352	00D 963 0223 009	R,THICK 0-J,1/16W		C20000006M160S		

FRONT P.W.B. UNIT ASS'Y

Ref. No.	Part No.	Part Name	Remarks	Q'ty	New
SEMICONDUCTORS GROUP					
IC301	00D 963 0074 504	IC BU2090F-E2		J044209000010S	
IC302	00D 262 3758 009	LC87F6D64A-QFP-E		J127876160010S	
△ IC303	00D 960 0195 808	IC ICP-N15		J120001500030S	
Q301-303	00D 963 0120 704	TR KRA102S		J520010200210S	
Q304	00D 963 0121 606	TR KRC107S		J522107S00210S	
Q305	00D 963 0102 803	TR 2SA933S		J5000933S0050S	
Q306	00D 963 0120 801	TR KRC102S		J522010200210S	
Q307-309	00D 963 0120 704	TR KRA102S		J520010200210S	
Q310,311	00D 963 0120 801	TR KRC102S		J522010200210S	
Q312	00D 960 0133 103	TR KSA916Y		J5000916Y0050S	
Q542-545	00D 963 0121 208	TR KRC107M		J6020107M0010S	
D301,302	00D 963 0020 309	D,SWITCHING 1SS133T		K000013300520S	
D303	00D 963 0355 401	D,SWITCHING KDS4148U		K005041480030S	
D304	00D 963 0020 309	D,SWITCHING 1SS133T		K000013300520S	
D305-311	00D 963 0355 401	D,SWITCHING KDS4148U		K005041480030S	
D312	00D 963 0328 409	D,SWITCHING 1N4007		K000400700010S	
D313-316	00D 963 0355 401	D,SWITCHING KDS4148U		K005041480030S	
D542	00D 963 0020 309	D,SWITCHING 1SS133T		K000013300520S	
D543-545	00D 963 0355 401	D,SWITCHING KDS4148U		K005041480030S	
ZD302-305	00D 960 0095 500	D,ZENER MTZJ5.1B		K06005R144520S	
ZD307,308	00D 960 0095 500	D,ZENER MTZJ5.1B		K06005R144520S	
ZD309	00D 960 0095 801	D,ZENER MTZJ6.8B		K06006R844520S	
ZD310,311	00D 963 0046 202	D,ZENER MTZJ18B		K06018R044520S	
LED302-309	00D 960 0197 204	LED PI5-RD/HL50RDRF4T		K500052015010S	
LED310	00D 963 0366 108	LED BL-BEG204-L 5PI		K500052004010S	
FL301	00D 963 0257 305	DISPLAY,FLT HNA-16SM13T		K530161300020S	
RESISTORS GROUP					
R372	00D 963 0215 907	R,METAL FILM 4.7-J,1W		C0604R7065050S	
R378,379	00D 960 9009 270	R,METAL FILM 470-J,2W		C060047166520S	
R501	00D 960 9003 700	R,METAL FILM 10-J,1/4W		C060010063050S	
RP1-38	00D 963 0353 005	R,CHIP THICK 56K-J,1/16W		C20005636M160S	
RG1-16	00D 963 0353 005	R,CHIP THICK 56K-J,1/16W		C20005636M160S	
CAPACITORS GROUP					
C301,302	nsp	C,CERAMIC 100PF-J/50V		D010101167160S	
C303	nsp	C,CERAMIC 0.022UF-K/25V		D011223777160S	
C304	00D 963 9005 862	C,ELECT 47UF-M/16V		D040470083080S	
C305	nsp	C,CERAMIC 100PF-J/50V		D010101167160S	
C306	nsp	C,CERAMIC 0.047UF-Z/50V		D011473597160S	
C307	00D 963 9005 862	C,ELECT 47UF-M/16V		D040470083080S	
C308	nsp	C,CERAMIC 0.01UF-K/50V		D011103777160S	
C311	00D 963 0233 303	C,CERAMIC 0.01UF-M/16V		D005103773530S	
C312	00D 963 9005 862	C,ELECT 47UF-M/16V		D040470083080S	
C316,317	nsp	C,CERAMIC 330PF-J/50V		D010331167160S	

Ref. No.	Part No.	Part Name	Remarks		Q'ty	New
C319,320	nsp	C,CERAMIC 0.01UF-K/50V		D011103777160S		
C321,322	00D 963 0233 303	C,CERAMIC 0.01UF-M/16V		D005103773530S		
C324,325	00D 963 0293 602	C,ELECT 1UF-M/50V (Pb Free)		D040010087150S		
C326	00D 963 9005 862	C,ELECT 47UF-M/16V		D040470083080S		
C327,328	nsp	C,CERAMIC 0.1UF-K/50V		D011104577160S		
C329	nsp	C,FILM 0.1UF-J/100V		D02010406C060S		
C330	00D 963 0021 900	C,FILM 0.047UF-J/100V		D02047306C060S		
C333	00D 963 0293 602	C,ELECT 1UF-M/50V (Pb Free)		D040010087150S		
C334	00D 963 0021 900	C,FILM 0.047UF-J/100V		D02047306C060S		
C339	nsp	C,CERAMIC 100PF-J/50V		D010101167160S		
C340	nsp	C,CERAMIC 1000PF-K/50V		D011102777160S		
C341,342	nsp	C,CERAMIC 100PF-J/50V		D010101167160S		
C343	00D 963 0020 202	C,CERAMIC 0.1UF-Z/50V		D005104597530S		
C344,345	00D 963 0233 206	C,CERAMIC 0.001UF-K/50V		D005102177530S		
C346-349	nsp	C,CERAMIC 0.01UF-K/50V		D011103777160S		
C350	00D 963 0021 900	C,FILM 0.047UF-J/100V		D02047306C060S		
C351	00D 963 0293 602	C,ELECT 1UF-M/50V (Pb Free)		D040010087150S		
C352	00D 963 0234 205	C,ELECT 10UF-M/50V		D040100087070S		
C353,354	00D 963 0293 602	C,ELECT 1UF-M/50V (Pb Free)		D040010087150S		
C355	nsp	C,ELECT 470UF-M/63V		D040471088010S		
C356	00D 963 9003 097	C,FILM 0.1UF-K/250V		D02010407H080S		
C357,358	nsp	C,CERAMIC 0.047UF-Z/50V		D011473597160S		
C541	nsp	C,CERAMIC 2200PF-K/50V		D011222777160S		
C541FL	00D 963 0024 703	C,FILM 0.01UF-J/100V		D02010306C060S		
C542	nsp	C,CERAMIC 2200PF-K/50V		D011222777160S		
C542FR	00D 963 0024 703	C,FILM 0.01UF-J/100V		D02010306C060S		
C543	nsp	C,CERAMIC 2200PF-K/50V		D011222777160S		
C543FL	00D 963 0024 703	C,FILM 0.01UF-J/100V		D02010306C060S		
C544	nsp	C,CERAMIC 2200PF-K/50V		D011222777160S		
C544FR	00D 963 0024 703	C,FILM 0.01UF-J/100V		D02010306C060S		
C545	nsp	C,CERAMIC 2200PF-K/50V		D011222777160S		
C545C	00D 963 0024 703	C,FILM 0.01UF-J/100V		D02010306C060S		
C546	nsp	C,CERAMIC 2200PF-K/50V		D011222777160S		
C546SL	00D 963 0024 703	C,FILM 0.01UF-J/100V		D02010306C060S		
C547	nsp	C,CERAMIC 2200PF-K/50V		D011222777160S		
C547SR	00D 963 0024 703	C,FILM 0.01UF-J/100V		D02010306C060S		
OTHERS PARTS GROUP						
BD301-304	nsp	COIL,BEAD MB-160808		D340160800060S		
CN301	nsp	CN,WIRE 2P		L000401020050S		
CN303A	nsp	CN,WIRE 8P		L000450080010S		
CN304	nsp	CN,WIRE 3P		L000500030050S		
CN305	nsp	CN,WIRE 10P		L000700100030S		
CN541	nsp	CN,WIRE 3P		L000251030080S		
CP101	nsp	CN.WAFER 10P		L102526701000S		
CP103	nsp	CN.WAFER 7P		L101220070000S		
CP105	nsp	CN.WAFER 4P ANGLE		L102526800400S		
CP301B	00D 963 0368 506	CN.FPC 35P		L131103500010S		
CP302	nsp	CN.WAFER 3P ANGLE		L102526803010S		
CP304	nsp	CN.WAFER 3P		L101220030000S		
CP305	nsp	CN.WAFER 10P		L101220100010S		
CP306	nsp	CN.WAFER 3P		L101220030010S		

Ref. No.	Part No.	Part Name	Remarks		Q'ty	New
G301	nsp	RING,TER WIRE 120MM/1P		8410121010060S		
G302	nsp	RING,TER WIRE 120MM/1P		8410121010110S		
G304	nsp	RING,TER WIRE 70MM/1P		8410700010070S		
JACK304	00D 963 0146 403	TER,RCA 3PIN		G606308HG110YS		
JACK501	00D 963 0146 607	TER,BOARD SCREW 8P		G614801A0200YS		
JACK502	00D 963 0257 208	TER,BOARD SCREW 4P		G612405E0200YS		
JACK503	00D 963 0158 608	TER,BOARD SCREW 2P		G611201A0200YS		
JK302	00D 963 0294 708	JACK,D6.5 PHONE		G402PJ612AG0YS		
L302	nsp	COIL INDUCTOR 10UH		D330100700520S		
L303	nsp	COIL INDUCTOR 100UH		D330101001020S		
RLY541	00D 963 0366 201	RELAY G5PA-28-MC 24V 5A		G680240502030S		
RLY543-545	00D 963 0366 201	RELAY G5PA-28-MC 24V 5A		G680240502030S		
RMC301	00D 963 0217 808	MODULE,REMOCON NJL34H380A		E940343800010S		
△ SW301	00D 963 0145 802	SW,PUSH SDDL-005-S(C-UL)		G000122006060S		
SW301A	00D 963 0095 305	SW,TACT SKHV10910D01		G180040500010S		
SW301C	00D 963 0095 305	SW,TACT SKHV10910D01		G180040500010S		
SW302A	00D 963 0095 305	SW,TACT SKHV10910D01		G180040500010S		
SW302B	00D 963 0095 305	SW,TACT SKHV10910D01		G180040500010S		
SW302C	00D 963 0095 305	SW,TACT SKHV10910D01		G180040500010S		
SW303A	00D 963 0095 305	SW,TACT SKHV10910D01		G180040500010S		
SW303B	00D 963 0095 305	SW,TACT SKHV10910D01		G180040500010S		
SW303C	00D 963 0095 305	SW,TACT SKHV10910D01		G180040500010S		
SW304A	00D 963 0095 305	SW,TACT SKHV10910D01		G180040500010S		
SW304B	00D 963 0095 305	SW,TACT SKHV10910D01		G180040500010S		
SW304C	00D 963 0095 305	SW,TACT SKHV10910D01		G180040500010S		
SW305A	00D 963 0095 305	SW,TACT SKHV10910D01		G180040500010S		
SW305B	00D 963 0095 305	SW,TACT SKHV10910D01		G180040500010S		
SW305C	00D 963 0095 305	SW,TACT SKHV10910D01		G180040500010S		
SW306A	00D 963 0095 305	SW,TACT SKHV10910D01		G180040500010S		
SW306B	00D 963 0095 305	SW,TACT SKHV10910D01		G180040500010S		
SW306C	00D 963 0095 305	SW,TACT SKHV10910D01		G180040500010S		
SW307A	00D 963 0095 305	SW,TACT SKHV10910D01		G180040500010S		
SW307B	00D 963 0095 305	SW,TACT SKHV10910D01		G180040500010S		
SW307C	00D 963 0095 305	SW,TACT SKHV10910D01		G180040500010S		
SW308A	00D 963 0095 305	SW,TACT SKHV10910D01		G180040500010S		
SW308B	00D 963 0095 305	SW,TACT SKHV10910D01		G180040500010S		
SW308C	00D 963 0095 305	SW,TACT SKHV10910D01		G180040500010S		
SW309A	00D 963 0095 305	SW,TACT SKHV10910D01		G180040500010S		
SW310	00D 963 0095 305	SW,TACT SKHV10910D01		G180040500010S		
VEC203	00D 963 0300 401	SW,ENCODER EC11B20C2		G121112020000S		
VEC301	00D 963 0095 208	SW,ENCODER EC16B24SO		G121162400070S		
VEC303	00D 963 0095 208	SW,ENCODER EC16B24SO		G121162400070S		
	nsp	HOLDER FLT		4320200026000S		

INPUT P.W.B. UNIT ASS'Y

Ref. No.	Part No.	Part Name	Remarks	Q'ty	New
SEMICONDUCTORS GROUP					
IC700	00D 963 0366 304	IC R2A15215FP		J084152150010S	
IC702	00D 963 0024 004	IC NJM2068M		J121206800020S	
IC705-716	00D 963 0024 004	IC NJM2068M		J121206800020S	
IC718	00D 963 0024 004	IC NJM2068M		J121206800020S	
Q700,701	00D 960 0196 807	TR 2SK117Y		J5441170Y0050S	
Q702	00D 963 0120 704	TR KRA102S		J520010200210S	
Q703	00D 960 0285 006	TR KRC104S		J522104S00210S	
D700,701	00D 963 0355 401	D,SWITCHING KDS4148U		K005041480030S	
ZD700,701	00D 960 0222 603	D,ZENER MTZJ7.5A		K06007R544530S	
RESISTORS GROUP					
R706-709	00D 963 9005 639	R,METAL FILM 100-J,1W		C060010165060S	
R791VC	nsp	R,METAL FILM 120-J,1W		C060012165060S	
R791VE	nsp	R,METAL FILM 120-J,1W		C060012165060S	
CAPACITORS GROUP					
C700	00D 963 0234 205	C,ELECT 10UF-M/50V		D040100087070S	
C702SW	00D 960 9010 010	C,ELECT 4.7UF-M/50V		D0404R7087250S	
C703C	nsp	C,CERAMIC 0.047UF-Z/50V		D011473597160S	
C703SW	nsp	C,CERAMIC 0.047UF-Z/50V		D011473597160S	
C704,705	00D 963 9005 875	C,ELECT 47UF-M/25V		D040470084070S	
C706FL	00D 963 9005 875	C,ELECT 47UF-M/25V		D040470084070S	
C706FR	00D 963 9005 875	C,ELECT 47UF-M/25V		D040470084070S	
C707FL	00D 963 0234 205	C,ELECT 10UF-M/50V		D040100087070S	
C707FR	00D 963 0234 205	C,ELECT 10UF-M/50V		D040100087070S	
C707SW	00D 963 0234 205	C,ELECT 10UF-M/50V		D040100087070S	
C708FL	nsp	C,CERAMIC 33PF-J/50V		D010330167160S	
C708FR	nsp	C,CERAMIC 33PF-J/50V		D010330167160S	
C708SW	nsp	C,CERAMIC 47PF-J/50V		D010470167160S	
C709FL	nsp	C,CERAMIC 0.047UF-Z/50V		D011473597160S	
C709FR	nsp	C,CERAMIC 0.047UF-Z/50V		D011473597160S	
C709SW	nsp	C,CERAMIC 0.047UF-Z/50V		D011473597160S	
C710	00D 963 0223 009	R,THICK 0-J,1/16W		C20000006M160S	
C710FL	nsp	C,CERAMIC 100PF-J/50V		D010101167160S	
C710FR	nsp	C,CERAMIC 100PF-J/50V		D010101167160S	
C710SW	nsp	C,CERAMIC 100PF-J/50V		D010101167160S	
C711	00D 963 0223 009	R,THICK 0-J,1/16W		C20000006M160S	
C711FL	nsp	C,CERAMIC 0.047UF-Z/50V		D011473597160S	
C711FR	nsp	C,CERAMIC 0.047UF-Z/50V		D011473597160S	
C711SW	nsp	C,CERAMIC 0.047UF-Z/50V		D011473597160S	
C712	00D 963 0293 602	C,ELECT 1UF-M/50V (Pb Free)		D040010087150S	
C713-715	00D 963 0223 009	R,THICK 0-J,1/16W		C20000006M160S	
C716-727	00D 960 9009 814	C,CERAMIC 330PF-J/50V		D010331167160S	
C728-731	nsp	C,CERAMIC 20PF-J/50V		D010200167160S	
C732-737	00D 960 9009 814	C,CERAMIC 330PF-J/50V		D010331167160S	
C740-751	00D 963 0234 205	C,ELECT 10UF-M/50V		D040100087070S	
C751A	00D 963 0234 205	C,ELECT 10UF-M/50V		D040100087070S	
C751B	00D 963 0234 205	C,ELECT 10UF-M/50V		D040100087070S	
C751C	00D 963 0234 205	C,ELECT 10UF-M/50V		D040100087070S	

Ref. No.	Part No.	Part Name	Remarks		Q'ty	New
C751D	00D 963 0234 205	C,ELECT 10UF-M/50V		D040100087070S		
C751E	00D 963 0234 205	C,ELECT 10UF-M/50V		D040100087070S		
C751F	00D 963 0234 205	C,ELECT 10UF-M/50V		D040100087070S		
C751G	00D 963 0234 205	C,ELECT 10UF-M/50V		D040100087070S		
C751H	00D 963 0234 205	C,ELECT 10UF-M/50V		D040100087070S		
C751J	00D 963 0234 205	C,ELECT 10UF-M/50V		D040100087070S		
C751K	00D 963 0234 205	C,ELECT 10UF-M/50V		D040100087070S		
C751L	00D 963 0234 205	C,ELECT 10UF-M/50V		D040100087070S		
C751M	00D 963 0234 205	C,ELECT 10UF-M/50V		D040100087070S		
C751N	00D 963 0234 205	C,ELECT 10UF-M/50V		D040100087070S		
C751P	00D 963 0234 205	C,ELECT 10UF-M/50V		D040100087070S		
C751Q	00D 963 0234 205	C,ELECT 10UF-M/50V		D040100087070S		
C751R	00D 963 0234 205	C,ELECT 10UF-M/50V		D040100087070S		
C751S	00D 963 0234 205	C,ELECT 10UF-M/50V		D040100087070S		
C751T	00D 963 0234 205	C,ELECT 10UF-M/50V		D040100087070S		
C752	00D 963 0234 205	C,ELECT 10UF-M/50V		D040100087070S		
C752A	nsp	C,CERAMIC 0.047UF-Z/50V		D011473597160S		
C752B	nsp	C,CERAMIC 0.047UF-Z/50V		D011473597160S		
C752C	nsp	C,CERAMIC 0.047UF-Z/50V		D011473597160S		
C752D	nsp	C,CERAMIC 0.047UF-Z/50V		D011473597160S		
C752E	nsp	C,CERAMIC 0.047UF-Z/50V		D011473597160S		
C752F	nsp	C,CERAMIC 0.047UF-Z/50V		D011473597160S		
C752G	nsp	C,CERAMIC 0.047UF-Z/50V		D011473597160S		
C752H	nsp	C,CERAMIC 0.047UF-Z/50V		D011473597160S		
C752J	nsp	C,CERAMIC 0.047UF-Z/50V		D011473597160S		
C752K	nsp	C,CERAMIC 0.047UF-Z/50V		D011473597160S		
C752L	nsp	C,CERAMIC 0.047UF-Z/50V		D011473597160S		
C752M	nsp	C,CERAMIC 0.047UF-Z/50V		D011473597160S		
C752N	nsp	C,CERAMIC 0.047UF-Z/50V		D011473597160S		
C752P	nsp	C,CERAMIC 0.047UF-Z/50V		D011473597160S		
C752Q	nsp	C,CERAMIC 0.047UF-Z/50V		D011473597160S		
C752R	nsp	C,CERAMIC 0.047UF-Z/50V		D011473597160S		
C752S	nsp	C,CERAMIC 0.047UF-Z/50V		D011473597160S		
C752T	nsp	C,CERAMIC 0.047UF-Z/50V		D011473597160S		
C752W	nsp	C,CERAMIC 0.1UF-Z/50V		D011104597160S		
C752X	nsp	C,CERAMIC 0.1UF-Z/50V		D011104597160S		
C753-761	00D 963 0234 205	C,ELECT 10UF-M/50V		D040100087070S		
C764-771	00D 963 0234 205	C,ELECT 10UF-M/50V		D040100087070S		
C772,773	00D 963 0293 806	C,ELECT 100UF-M/10V (Pb Free)		D040101082090S		
C774	nsp	C,FILM 0.15UF-K/63V		D020154078060S		
C775	00D 963 0021 900	C,FILM 0.047UF-J/100V		D02047306C060S		
C776	00D 960 9008 640	C,FILM 0.022UF-J/100V		D02022306C060S		
C777	00D 963 0234 205	C,ELECT 10UF-M/50V		D040100087070S		
C778,779	nsp	C,CERAMIC 100PF-J/50V		D010101167160S		
C780	00D 963 0234 205	C,ELECT 10UF-M/50V		D040100087070S		
C781	00D 960 9008 640	C,FILM 0.022UF-J/100V		D02022306C060S		
C782	00D 963 0021 900	C,FILM 0.047UF-J/100V		D02047306C060S		
C783	nsp	C,FILM 0.15UF-K/63V		D020154078060S		
C784-790	00D 963 0293 806	C,ELECT 100UF-M/10V (Pb Free)		D040101082090S		
C791-793	00D 963 0234 205	C,ELECT 10UF-M/50V		D040100087070S		
C794	00D 963 0293 806	C,ELECT 100UF-M/10V (Pb Free)		D040101082090S		
C795-799	00D 963 0234 205	C,ELECT 10UF-M/50V		D040100087070S		
C800,801	00D 960 9010 832	C,ELECT 10UF-M/16V		D040100083050S		

Ref. No.	Part No.	Part Name	Remarks		Q'ty	New
OTHERS PARTS GROUP						
CLAMP501	nsp	CLAMP WIRE(SOLDER)		4330000120000S		
CN306	nsp	CN,WIRE 480MM/3P		L000481030060S		
CN514	nsp	CN,WIRE 13P		L000181130010S		
CN702	nsp	CN.HOUSING 15P		L120912150010S		
CN703	nsp	CN.WAFER 8P		L101100030810S		
CN704	nsp	CN.WAFER 19P		L101100031910S		
CN706	nsp	CN,WIRE 8P		L000121050080S		
CP704	nsp	CN.WAFER 15P		L101220110000S		
JACK701	90M -YT 0046 40R	TER,RCA 2PIN		G601207AE020YS		
JACK702	00D 963 0387 505	TER,RCA 4PIN		G602405B5500YS		
JACK703	00D 963 0132 103	TER,RCA 4PIN		G602405B0400YS		
JACK704,705	00D 963 0132 307	TER,RCA 6PIN		G603603B05000S		

POWER P.W.B. UNIT ASS'Y

	Ref. No.	Part No.	Part Name	Remarks		Q'ty	New
SEMICONDUCTORS GROUP							
△	IC501	00D 963 0057 806	IC KIA78R05PI		J126780500370S		
	IC502	00D 960 0195 808	IC ICP-N15		J120001500030S		
	IC515	00D 960 0174 900	IC KIA7815API		J126781500000S		
	IC516	00D 963 0021 502	IC KIA7915PI		J126791500030S		
	IC517	00D 960 0100 301	IC KIA7812API		J126781200040S		
	Q501	00D 960 0196 409	TR 2SC1740SR		J5021740S0010S		
	Q502	00D 963 0121 208	TR KRC107M		J6020107M0010S		
	Q503	00D 960 0196 409	TR 2SC1740SR		J5021740S0010S		
	D501-503	00D 276 0401 905	D,SWITCHING 1SS133T		K000013300520S		
	D504-507	00D 963 0328 409	D,SWITCHING 1N4007		K000400700010S		
	D508,509	00D 276 0401 905	D,SWITCHING 1SS133T		K000013300520S		
	D521,522	00D 276 0401 905	D,SWITCHING 1SS133T		K000013300520S		
	D523-526	00D 963 0328 409	D,SWITCHING 1N4007		K000400700010S		
	ZD501	00D 960 0095 500	D,ZENER MTZJ5.1B		K06005R144520S		
	ZD502	00D 963 0219 903	D,ZENER MTZJ16B		K06016R044520S		
RESISTORS GROUP							
	R506	00D 963 0244 305	R,METAL FILM 2.2M 0.5W		C060022564520S		
	R507	00D 963 0232 809	R,METAL FILM 10-J,1/4W		C060010063520S		
	R516-519	00D 963 0216 003	R,METAL FILM 0.22-J,1W		C060R22065050S		
	R520	00D 963 0215 907	R,METAL FILM 4.7-J,1W		C0604R7065050S		
CAPACITORS GROUP							
	C501	00D 963 0234 205	C,ELECT 10UF-M/50V		D040100087070S		
	C502	00D 963 0217 002	C,ELECT 3300UF-M/16V		D040332083010S		
	C503	00D 963 0293 602	C,ELECT 1UF-M/50V (Pb Free)		D040010087150S		
	C504	00D 963 0323 802	C,CERAMIC AC(SAFETY) 0.0047UF 250VAC		D00847208H010S		
	C506	00D 963 0293 602	C,ELECT 1UF-M/50V (Pb Free)		D040010087150S		
	C526,527	00D 960 0186 202	C,ELECT 220UF-M/35V		D040221085050S		
	C528	00D 963 0324 908	C,ELECT 4700UF-M/35V		D040472085020S		
	C529	00D 963 0224 707	C,ELECT 2200UF-M/35V		D040222085020S		
	C530-532	00D 963 0021 900	C,FILM 0.047UF-J/100V		D02047306C060S		
	C534,535	00D 963 0234 205	C,ELECT 10UF-M/50V		D040100087070S		
OTHERS PARTS GROUP							
	BKT501	nsp	SHIELD PLATE GND		3070045526010S		
	CLAMP102-105	nsp	CLAMP WIRE(SOLDER)		4330000120000S		
	CN505	nsp	CN.WAFER 7P		L101100030710S		
	CN506	nsp	CN.WAFER 12P		L101100031210S		
	CP501	nsp	CN.WAFER 2CKT,YEL		L108353280290S		
	CP503	nsp	CN.WAFER 2CKT,RED		L108353280280S		
	CP504	nsp	CN.WAFER ST2P		L108202000220S		
	CP505	nsp	CN.WAFER 7P		L101100040710S		
	CP506	nsp	CN.WAFER 12P		L101100041210S		
	CP511	nsp	CN.WAFER 9P		L101220090000S		

	Ref. No.	Part No.	Part Name	Remarks		Q'ty	New
	CP513	nsp	CN.WAFER 3P ANGLE		L102526803010S		
	CP514	nsp	CN.WAFER 13P		L101220130000S		
⚠	F501	00D 963 0236 106	FUSE T8A /250V		N751228001110S		
	F501A	nsp	HOLDER,FUSE CLIP		G645000050010S		
	F501B	nsp	HOLDER,FUSE CLIP		G645000050010S		
⚠	F503	00D 963 0236 106	FUSE T8A /250V		N751228001110S		
	F503A	nsp	HOLDER,FUSE CLIP		G645000050010S		
	F503B	nsp	HOLDER,FUSE CLIP		G645000050010S		
	GND501	nsp	TERMINAL EARTH		3790040886000S		
	RLY501	00D 963 0218 205	RELAY HL3-1A-9SH DC9V 1A		G680090102020S		
⚠	SUB501	00D 963 0387 602	SUB TRANS		8200280150401S		
		nsp	HEAT SINK		2120043538050S		
		nsp	HEAT SINK		2120044298010S		
		nsp	SCREW,TAP TITE +2S 3*8 B-TYPE ZNW/BH		B020030081B10S		
⚠		00D 963 0328 409	D,SWITCHING 1N4007		K000400700010S		
		00D 203 3976 002	SOCKET,POWER RECEPTA		G435204004010S		

2CH-POWER P.W.B. UNIT ASS'Y

Ref. No.	Part No.	Part Name	Remarks	Q'ty	New
SEMICONDUCTORS GROUP					
IC401D4	00D 960 0159 501	IC KIA7805API		J126780500110S	
IC401H	963603000090S	CN,WIRE 80MM/3P		L000800030160S	
IC401X4	00D 963 0334 503	IC PQ20RX11		J126201100010S	
IC402D4	00D 963 0226 608	IC KIA78R33PI		J12678R330010S	
IC402X4	00D 963 0366 603	IC KIA1117PI50		J126111750050S	
IC403D4	00D 963 0366 706	IC KIA1117PI00		J126111700050S	
Q401X4	00D 963 0120 801	TR KRC102S		J522010200210S	
Q402D4	00D 960 0097 304	TR KRC102M		J6020102M0010S	
Q402X4	00D 963 0120 801	TR KRC102S		J522010200210S	
Q409D4	00D 960 0097 304	TR KRC102M		J6020102M0010S	
D401H4	00D 963 0328 409	D,SWITCHING 1N4007		K000400700010S	
D401X4	00D 963 0328 409	D,SWITCHING 1N4007		K000400700010S	
D402H4	00D 963 0328 409	D,SWITCHING 1N4007		K000400700010S	
D402X4	00D 963 0328 409	D,SWITCHING 1N4007		K000400700010S	
ZD401D4	00D 960 0095 607	D,ZENER MTZJ5.6B		K06005R644520S	
RESISTORS GROUP					
R401D4	00D 963 9006 269	R,FIXED 1WJ-0.22		N113135622820S	
R401H4	00D 963 9006 269	R,FIXED 1WJ-0.22		N113135622820S	
R401X4	00D 963 9006 269	R,FIXED 1WJ-0.22		N113135622820S	
R402D4	00D 963 9006 269	R,FIXED 1WJ-0.22		N113135622820S	
R402H4	00D 963 9006 269	R,FIXED 1WJ-0.22		N113135622820S	
R402X4	00D 963 9006 269	R,FIXED 1WJ-0.22		N113135622820S	
CAPACITORS GROUP					
C401D4	00D 963 0021 900	C,FILM 0.047UF-J/100V		D02047306C060S	
C401H4	00D 963 0021 900	C,FILM 0.047UF-J/100V		D02047306C060S	
C401X4	nsp	C,CERAMIC 0.1UF-K/50V		D011104577160S	
C402D4	00D 963 0021 900	C,FILM 0.047UF-J/100V		D02047306C060S	
C402H4	00D 963 0021 900	C,FILM 0.047UF-J/100V		D02047306C060S	
C402X4	00D 963 9003 097	C,FILM 0.1UF-K/250V		D02010407H080S	
C403D4	00D 963 0021 900	C,FILM 0.047UF-J/100V		D02047306C060S	
C403H4	00D 963 0021 900	C,FILM 0.047UF-J/100V		D02047306C060S	
C403X4	00D 960 0133 404	C,ELECT 10000UF 16V		D040103083020S	
C404D4	00D 960 0133 404	C,ELECT 10000UF 16V		D040103083020S	
C404H4	00D 963 0217 002	C,ELECT 3300UF-M/16V		D040332083010S	
C404X4	00D 963 0276 409	C,ELECT 100UF-M/16V		D040101083090S	
C405D4	00D 963 0338 402	C,ELECT 330UF-M/6.3V		D040331081050S	
C406D4	nsp	C,CERAMIC 0.1UF-K/50V		D011104577160S	
C406X4	nsp	C,CERAMIC 1000PF-K/50V		D011102777160S	
C407D4	nsp	C,CERAMIC 1000PF-K/50V		D011102777160S	
C407X4	00D 963 0293 709	C,ELECT 100UF-M/10V		D040101082070S	
C408D4	00D 963 0338 402	C,ELECT 330UF-M/6.3V		D040331081050S	
C408X4	00D 963 0293 709	C,ELECT 100UF-M/10V		D040101082070S	
C409D4	nsp	C,CERAMIC 0.1UF-K/50V		D011104577160S	
C410D4	00D 963 0338 402	C,ELECT 330UF-M/6.3V		D040331081050S	
C411D4	nsp	C,CERAMIC 0.1UF-K/50V		D011104577160S	
C412D4	nsp	C,CERAMIC 0.1UF-K/50V		D011104577160S	
C413D4	00D 963 0024 907	C,ELECT 1000UF-M/6.3V		D040102081060S	

Ref. No.	Part No.	Part Name	Remarks		Q'ty	New
C443X4	nsp	C,CERAMIC 1000PF-K/50V		D011102777160S		
OTHERS PARTS GROUP						
CN405X4	nsp	CN,WIRE 5P		L000401050030S		
CN904D4	nsp	CN,WIRE 6P		L000201060010S		
CP401	nsp	CN.WAFER 3P		L102526700300S		

CPU P.W.B. UNIT ASS'Y

Ref. No.	Part No.	Part Name	Remarks	Q'ty	New
SEMICONDUCTORS GROUP					
IC713-715	00D 963 0024 004	IC NJM2068M	M30626FHPFP	J121206800020S	
IC804	963243000020D	IC,CPU MICRO PROCESS		8952150800015	
IC806	00D 960 0100 301	IC KIA7812API		J126781200040S	
IC813	00D 963 0367 204	IC SN74HC151PWR		J040741510070S	
IC817	00D 963 0244 907	IC SN74LV14APWR		J040741400180S	
IC818	00D 963 0367 307	IC SN74AHCU04PWR		J040740400290S	
IC824	00D 963 0043 807	IC BA4510F-E2/SOP8		J121451000010S	
IC827	00D 963 0043 807	IC BA4510F-E2/SOP8		J121451000010S	
IC830	00D 262 2813 903	SN74AHCT08PW-EL2 +C		J040740800190S	
Q704C	00D 963 0044 301	TR KTC2875B(MB)	<div style="border: 1px solid black; border-radius: 15px; padding: 5px; width: fit-content;"> ファームウェアをアップデートするときは、SDIで最終バージョンを確認して下さい。サービス基板はアップデートして使用下さい。 When update Firmware, please confirm a last version in SDI. Use the service board after updating it. </div>	J5222875B0010S	
Q704FL	00D 963 0044 301	TR KTC2875B(MB)		J5222875B0010S	
Q704FR	00D 963 0044 301	TR KTC2875B(MB)		J5222875B0010S	
Q704SL	00D 963 0044 301	TR KTC2875B(MB)		J5222875B0010S	
Q704SR	00D 963 0044 301	TR KTC2875B(MB)		J5222875B0010S	
Q704SW	00D 963 0044 301	TR KTC2875B(MB)		J5222875B0010S	
Q801	00D 963 0120 704	TR KRA102S		J520010200210S	
Q802-805	00D 963 0044 301	TR KTC2875B(MB)		J5222875B0010S	
Q806	00D 963 0121 509	TR KTC3875S		J522038750210S	
Q807	00D 960 0285 006	TR KRC104S		J522104S00210S	
Q810D	00D 963 0245 100	D,SWITCHING KDS226ST1(C3)		K005022600020S	
Q811D	00D 963 0245 100	D,SWITCHING KDS226ST1(C3)		K005022600020S	
Q812D	00D 963 0120 801	TR KRC102S		J522010200210S	
Q813D	00D 963 0120 704	TR KRA102S		J520010200210S	
D801-804	00D 963 0355 401	D,SWITCHING KDS4148U		K005041480030S	
D805	00D 963 0328 409	D,SWITCHING 1N4007		K000400700010S	
D807	00D 963 0355 401	D,SWITCHING KDS4148U		K005041480030S	
D807D	00D 963 0355 401	D,SWITCHING KDS4148U		K005041480030S	
D808D	00D 963 0341 305	D,ESD IMSA-6802-01A		K067680200010S	
D809D	00D 963 0355 401	D,SWITCHING KDS4148U		K005041480030S	
D810D	00D 963 0341 305	D,ESD IMSA-6802-01A		K067680200010S	
D811D	00D 963 0341 305	D,ESD IMSA-6802-01A		K067680200010S	
ZD801	00D 963 0047 502	D,ZENER MTZJ3.3B		K06003R344520S	
RESISTORS GROUP					
R857	00D 960 9003 807	R,METAL 100-J,1/4W		C060010163050S	
CAPACITORS GROUP					
C751C	00D 963 0234 205	C,ELECT 10UF-M/50V		D040100087070S	
C751FL	00D 963 0234 205	C,ELECT 10UF-M/50V		D040100087070S	
C751FR	00D 963 0234 205	C,ELECT 10UF-M/50V		D040100087070S	
C751SL	00D 963 0234 205	C,ELECT 10UF-M/50V		D040100087070S	
C751SR	00D 963 0234 205	C,ELECT 10UF-M/50V		D040100087070S	
C751SW	00D 963 0234 205	C,ELECT 10UF-M/50V		D040100087070S	
C752C	00D 963 0350 503	C,CERAMIC 390PF-J/50V		D010391167160S	
C752FL	00D 963 0223 708	C,CERAMIC 270PF-J/50V		D010271167160S	
C752FR	00D 963 0223 708	C,CERAMIC 270PF-J/50V		D010271167160S	
C752SL	00D 960 9009 814	C,CERAMIC 330PF-J/50V		D010331167160S	
C752SR	00D 960 9009 814	C,CERAMIC 330PF-J/50V		D010331167160S	
C752SW	00D 963 0350 503	C,CERAMIC 390PF-J/50V		D010391167160S	

Ref. No.	Part No.	Part Name	Remarks		Q'ty	New
C753C	00D 963 0224 008	C,CERAMIC 470PF-J/50V		D010471167160S		
C753FL	00D 963 0223 902	C,CERAMIC 39PF-J/50V		D010390167160S		
C753FR	00D 963 0223 902	C,CERAMIC 39PF-J/50V		D010390167160S		
C753SL	00D 963 0223 708	C,CERAMIC 270PF-J/50V		D010271167160S		
C753SR	00D 963 0223 708	C,CERAMIC 270PF-J/50V		D010271167160S		
C753SW	00D 963 0224 008	C,CERAMIC 470PF-J/50V		D010471167160S		
C755C	nsp	C,CERAMIC 0.1UF-Z/50V		D011104597160S		
C755FL	nsp	C,CERAMIC 0.1UF-Z/50V		D011104597160S		
C755FR	nsp	C,CERAMIC 0.1UF-Z/50V		D011104597160S		
C755SL	nsp	C,CERAMIC 0.1UF-Z/50V		D011104597160S		
C755SR	nsp	C,CERAMIC 0.1UF-Z/50V		D011104597160S		
C755SW	nsp	C,CERAMIC 0.1UF-Z/50V		D011104597160S		
C756C	00D 963 9003 194	C,FILM 0.0022UF-J/100V		D02022206C060S		
C756FL	00D 963 9003 194	C,FILM 0.0022UF-J/100V		D02022206C060S		
C756FR	00D 963 9003 194	C,FILM 0.0022UF-J/100V		D02022206C060S		
C756SL	00D 963 9003 194	C,FILM 0.0022UF-J/100V		D02022206C060S		
C756SR	00D 963 9003 194	C,FILM 0.0022UF-J/100V		D02022206C060S		
C756SW	00D 963 9003 194	C,FILM 0.0022UF-J/100V		D02022206C060S		
C757C	nsp	C,CERAMIC 10UF-Z/10V		D011106592200S		
C757FL	nsp	C,CERAMIC 10UF-Z/10V		D011106592200S		
C757FR	nsp	C,CERAMIC 10UF-Z/10V		D011106592200S		
C757SL	nsp	C,CERAMIC 10UF-Z/10V		D011106592200S		
C757SR	nsp	C,CERAMIC 10UF-Z/10V		D011106592200S		
C757SW	nsp	C,CERAMIC 10UF-Z/10V		D011106592200S		
C803	nsp	C,CERAMIC 100PF-J/50V		D010101167160S		
C804,805	nsp	C,CERAMIC 0.1UF-Z/50V		D011104597160S		
C806	nsp	C,CERAMIC 0.01UF-K/50V		D011103777160S		
C807,808	nsp	C,CERAMIC 0.022UF-Z/50V		D011223597160S		
C809	00D 963 0293 709	C,ELECT 100UF-M/10V		D040101082070S		
C810	nsp	C,CERAMIC 0.1UF-Z/50V		D011104597160S		
C813	nsp	C,CERAMIC 0.1UF-Z/50V		D011104597160S		
C814-816	nsp	C,CERAMIC 0.01UF-K/50V		D011103777160S		
C818	00D 960 9010 010	C,ELECT 4.7UF-M/50V		D0404R7087250S		
C819	nsp	C,CERAMIC 0.01UF-K/50V		D011103777160S		
C824,825	00D 963 0234 205	C,ELECT 10UF-M/50V		D040100087070S		
C826-831	nsp	C,CERAMIC 100PF-J/50V		D010101167160S		
C836,837	nsp	C,CERAMIC 0.022UF-Z/50V		D011223597160S		
C865L	nsp	C,CERAMIC 120PF-J/50V		D010121167160S		
C865R	nsp	C,CERAMIC 120PF-J/50V		D010121167160S		
C871L	00D 963 0216 304	C,FILM 0.001UF-J/100V		D02010206C060S		
C871R	00D 963 0216 304	C,FILM 0.001UF-J/100V		D02010206C060S		
C916D	nsp	C,CERAMIC 0.1UF-Z/50V		D011104597160S		
C917D	nsp	C,CERAMIC 0.1UF-Z/50V		D011104597160S		
C918D	nsp	C,CERAMIC 0.1UF-Z/50V		D011104597160S		
C921D	nsp	C,CERAMIC 100PF-J/50V		D010101167160S		
C923D	nsp	C,CERAMIC 22PF-J/50V		D010220167160S		
C924D	nsp	C,CERAMIC 22PF-J/50V		D010220167160S		
C927D	00D 963 9005 862	C,ELECT 47UF-M/16V		D040470083080S		
C928D	00D 963 9005 862	C,ELECT 47UF-M/16V		D040470083080S		
C931D	nsp	C,CERAMIC 100PF-J/50V		D010101167160S		
C932D	nsp	C,CERAMIC 0.01UF-K/50V		D011103777160S		
C933D	nsp	C,CERAMIC 0.01UF-K/50V		D011103777160S		
C934D	nsp	C,CERAMIC 0.01UF-K/50V		D011103777160S		
C935D	00D 960 9010 010	C,ELECT 4.7UF-M/50V		D0404R7087250S		
C936D	00D 960 9010 010	C,ELECT 4.7UF-M/50V		D0404R7087250S		
C937D	nsp	C,CERAMIC 1000PF-K/50V		D011102777160S		

Ref. No.	Part No.	Part Name	Remarks		Q'ty	New
C938D	00D 960 9010 010	C,ELECT 4.7UF-M/50V		D0404R7087250S		
C939D	nsp	C,CERAMIC 0.01UF-K/50V		D011103777160S		
C940D	nsp	C,CERAMIC 0.01UF-K/50V		D011103777160S		
C941D	00D 963 0244 606	C,ELECT 0.1UF-M/50V (Pb Free)		D040R10087080S		
C950D	nsp	C,CERAMIC 0.1UF-Z/50V		D011104597160S		
C951D	nsp	C,CERAMIC 0.1UF-Z/50V		D011104597160S		
C952D	00D 963 0234 205	C,ELECT 10UF-M/50V		D040100087070S		
C953D	00D 963 0234 205	C,ELECT 10UF-M/50V		D040100087070S		
C954D	nsp	C,CERAMIC 0.1UF-Z/50V		D011104597160S		
C955D	nsp	C,CERAMIC 0.1UF-Z/50V		D011104597160S		
C956D	nsp	C,CERAMIC 22PF-J/50V		D010220167160S		
C957D	nsp	C,CERAMIC 0.1UF-Z/50V		D011104597160S		
C959D	nsp	C,CERAMIC 22PF-J/50V		D010220167160S		
BC801	00D 254 4666 005	CE04W0H105ZC(FG)		D041105090010S		
OTHERS PARTS GROUP						
BD802-809	nsp	COIL,BEAD MB-160808		D340160800060S		
BD809D	nsp	COIL,BEAD MB-160808		D340160800060S		
BD810-817	nsp	COIL,BEAD MB-160808		D340160800060S		
CN106	nsp	CN.WAFER 5P		L101100030510S		
CN108	00D 963 0085 302	CN.WAFER 17P		L101100031710S		
CP01	nsp	CN.WAFER 16P		L101100041610S		
CP301A	00D 963 0367 400	CN.FPC 35P		L131524923520S		
CP701	nsp	CN.WAFER 19P		L101100041910S		
CP702	nsp	CN.WAFER 15P		L100912150010S		
CP703	nsp	CN.WAFER 8P		L101100040810S		
CP801	00D 963 0149 303	CN.FPC 15P		L131111500010S		
CP802	nsp	CN.WAFER 16P		L100912160010S		
CP803	nsp	CN.WAFER 16P		L101100041610S		
CP804	nsp	CN.WAFER 15P		L100912150010S		
CP805	nsp	CN.WAFER 08P		L100912080010S		
CP1001	nsp	CN.WAFER 08P		L101100040810S		
CP1002	nsp	CN.WAFER 9P		L101100040910S		
JACK801	00D 963 0217 905	TER,RCA 2PIN		G601206A0200YS		
JACK802	00D 963 0294 601	JACK,D3.5 EARPHONE		G40100350000YS		
L801D	nsp	COIL INDUCTOR 4.7UH		D3304R7000150S		
L802D	nsp	COIL INDUCTOR 4.7UH		D3304R7000150S		
L803D	nsp	COIL INDUCTOR 4.7UH		D3304R7000150S		
L805D	nsp	COIL INDUCTOR 4.7UH		D3304R7000150S		
L806D	nsp	COIL INDUCTOR 22UH		D330220010520S		
L807D	nsp	COIL INDUCTOR 22UH		D330220010520S		
TP803	nsp	CN.WAFER 8P		L101220080000S		
TP804	nsp	CN.WAFER 4P		L101220040000S		
X801	00D 963 0217 701	RESONATOR,CERAMIC ZTT12.00MT		E830120000060S		
OPT801D	00D 963 0237 503	MODULE JSR1165-C		E100116500040S		
OPT802D	00D 963 0237 503	MODULE JSR1165-C		E100116500040S		
	nsp	CN,WIRE 110MM/1P		L000111010010S		

HDMI P.W.B. UNIT ASS'Y

Ref. No.	Part No.	Part Name	Remarks	Q'ty	New
SEMICONDUCTORS GROUP					
IC01	nsp	SII9185CTU		00D2623721007	
IC03	nsp	IC SE1117-1.8		J126111718010S	
IC04	nsp	IC F2621E-01-PR		J080260200040S	
IC05	nsp	IC SE1117-33-PF		J126111733020S	
IC06	nsp	IC AK4385		J042438500010S	
IC07	nsp	SN74LV08APW-EL2 +REF		00D2622517908	
IC08,09	nsp	SN74AHCT08PW-EL2 +C		00D2622813903	
IC10	nsp	IC NJM2068M		J121206800020S	
IC11	nsp	IC KIA1117PI50		J126111750050S	
IC12	nsp	IC BU4094BCF-E2		J040140940030S	
IC801	nsp	ADSP21367KSZ1A1136		00D2623709016	
IC802	nsp	W9864G2GH-7		00D2623746008	
IC803	nsp	IC EN29LV160T-70TCP		J005291600010S	
IC807	nsp	LC89057W-VF4A		00D2623449004	
IC808	nsp	ADAU1328BSTZ1136		00D2623645015	
IC809-811	nsp	IC SN74LVC244APWR		J040742440230S	
IC812	nsp	IC SN74HCT244PWR		J040742440220S	
IC814,815	nsp	IC SN74HCT00PWR		J040740000210S	
IC816	nsp	74LVX157MTC +C		00D2622870904	
IC823	nsp	IC KIA7805API		J126780500110S	
IC825,826	nsp	IC SN74LVC74APWR		J040747400200S	
IC832	nsp	IC SE1117-33-PF		J126111733020S	
Q01,02	nsp	TR KRC102S		J522010200210S	
Q03,04	nsp	TR KRC104S		J522104S00210S	
Q05	nsp	TR KRA102S		J520010200210S	
Q06	nsp	TR KTC3875S		J522038750210S	
Q07	nsp	TR KRC104S		J522104S00210S	
Q08	nsp	TR KRC102S		J522010200210S	
Q09	nsp	TR KRA104S		J520010400210S	
Q10,11	nsp	TR KRC102S		J522010200210S	
Q12,13	nsp	TR KRA102S		J520010200210S	
Q14-17	nsp	TR KTC2875B(MB)		J5222875B0010S	
Q810D	nsp	TR KRC102S		J522010200210S	
Q811D	nsp	TR KRA102S		J520010200210S	
Q814D	nsp	TR KRA102S		J520010200210S	
D01-36	nsp	D,ESD IMSA-6802-01A		K067680200010S	
D37-44	nsp	D,SWITCHING KDS4148U		K005041480030S	
RESISTORS GROUP					
R41,42	nsp	COIL,BEAD MB-160808		D340160800060S	
R62	nsp	COIL,BEAD MB-160808		D340160800060S	
CAPACITORS GROUP					
C01	nsp	C,CERAMIC 1000PF-K/50V		D011102777160S	
C02-05	nsp	C,CERAMIC 0.1UF-K/50V		D011104577162S	
C06,07	nsp	C,CERAMIC 1000PF-K/50V		D011102777160S	
C08-14	nsp	C,CERAMIC 0.1UF-K/50V		D011104577162S	
C15-17	nsp	C,CERAMIC 1000PF-K/50V		D011102777160S	
C18,19	nsp	C,CERAMIC 0.1UF-K/50V		D011104577162S	
C20	nsp	C,CERAMIC 1000PF-K/50V		D011102777160S	

Ref. No.	Part No.	Part Name	Remarks		Q'ty	New
C21	nsp	C,CERAMIC 100PF-J/50V		D010101167160S		
C22	nsp	C,CERAMIC 1000PF-K/50V		D011102777160S		
C23	nsp	C,CERAMIC 100PF-J/50V		D010101167160S		
C24,25	nsp	C,ELECT 10UF-MVG/16V		D050100083460S		
C26,27	nsp	C,CERAMIC 0.01UF-K/50V		D011103777160S		
C28H	nsp	C,ELECT 10UF-MVG/16V		D050100083460S		
C29	nsp	C,CERAMIC 0.1UF-K/50V		D011104577162S		
C29H	nsp	C,ELECT 10UF-MVG/16V		D050100083460S		
C30	nsp	C,CERAMIC 0.1UF-K/50V		D011104577162S		
C30H	nsp	C,ELECT 10UF-MVG/16V		D050100083460S		
C31,32	nsp	C,CERAMIC 0.1UF-K/50V		D011104577162S		
C33-36	nsp	C,CERAMIC 20PF-J/50V		D010200167160S		
C37-39	nsp	C,CERAMIC 0.1UF-K/50V		D011104577162S		
C40	nsp	C,ELECT 22UF-MV/6.3V		D050220081450S		
C41	nsp	C,CERAMIC 0.1UF-K/50V		D011104577162S		
C42,43	nsp	C,CERAMIC 5PF-C/50V		D010050107160S		
C44	nsp	C,CERAMIC 0.1UF-K/50V		D011104577162S		
C45	nsp	C,CERAMIC 1000PF-K/50V		D011102777160S		
C46	nsp	C,CERAMIC 4.7UF-K/10V		D011475572200S		
C47-50	nsp	C,CERAMIC 0.1UF-K/50V		D011104577162S		
C51	nsp	C,CERAMIC 1000PF-K/50V		D011102777160S		
C52	nsp	C,CERAMIC 0.1UF-K/50V		D011104577162S		
C53	nsp	C,ELECT 10UF-MVG/16V		D050100083460S		
C54	nsp	C,CERAMIC 0.1UF-K/50V		D011104577162S		
C55	nsp	C,CERAMIC 4.7UF-K/10V		D011475572200S		
C56,57	nsp	C,CERAMIC 1000PF-K/50V		D011102777160S		
C58	nsp	C,CERAMIC 0.1UF-K/50V		D011104577162S		
C59	nsp	C,CERAMIC 1000PF-K/50V		D011102777160S		
C60	nsp	C,CERAMIC 0.1UF-K/50V		D011104577162S		
C61	nsp	C,CERAMIC 1000PF-K/50V		D011102777160S		
C62	nsp	C,CERAMIC 0.1UF-K/50V		D011104577162S		
C63-65	nsp	C,CERAMIC 100PF-J/50V		D010101167160S		
C66	nsp	C,CERAMIC 0.01UF-K/50V		D011103777160S		
C68	nsp	C,ELECT 0.1UF-MVG/50V		D050R10080010S		
C69,70	nsp	C,CERAMIC 0.1UF-K/50V		D011104577162S		
C71,72	nsp	C,ELECT 22UF-MV/6.3V		D050220081450S		
C73,74	nsp	C,ELECT 10UF-MVG/16V		D050100083460S		
C75	nsp	C,CERAMIC 560PF-J/50V		D010561167160S		
C76	nsp	C,CERAMIC 1800PF-K/50V		D011182777160S		
C77,78	nsp	C,CERAMIC 560PF-J/50V		D010561167160S		
C79	nsp	C,CERAMIC 1800PF-K/50V		D011182777160S		
C80	nsp	C,CERAMIC 560PF-J/50V		D010561167160S		
C82	nsp	C,CERAMIC 1000PF-K/50V		D011102777160S		
C831D	nsp	C,CERAMIC 0.1UF-K/50V		D011104577162S		
C832D	nsp	C,CERAMIC 1000PF-K/50V		D011102177101S		
C833D	nsp	C,CERAMIC 100PF-J/50V		D011101167101S		
C834D	nsp	C,CERAMIC 100PF-J/50V		D011101167101S		
C835D	nsp	C,CERAMIC 0.01UF-K/50V		D011103177101S		
C836D	nsp	C,CERAMIC 0.01UF-K/50V		D011103177101S		
C837D	nsp	C,CERAMIC 100PF-J/50V		D011101167101S		
C838D	nsp	C,CERAMIC 100PF-J/50V		D011101167101S		
C839D	nsp	C,CERAMIC 100PF-J/50V		D011101167101S		
C840D	nsp	C,CERAMIC 100PF-J/50V		D011101167101S		
C841D	nsp	C,CERAMIC 100PF-J/50V		D011101167101S		
C842D	nsp	C,CERAMIC 100PF-J/50V		D011101167101S		
C843D	nsp	C,CERAMIC 100PF-J/50V		D011101167101S		

Ref. No.	Part No.	Part Name	Remarks		Q'ty	New
C844D	nsp	C,CERAMIC 100PF-J/50V		D011101167101S		
C845D	nsp	C,CERAMIC 0.1UF-K/50V		D011104177101S		
C846D	nsp	C,CERAMIC 1000PF-K/50V		D011102177101S		
C847D	nsp	C,CERAMIC 1000PF-K/50V		D011102177101S		
C848D	nsp	C,CERAMIC 1000PF-K/50V		D011102177101S		
C849D	nsp	C,CERAMIC 1000PF-K/50V		D011102177101S		
C850D	nsp	C,CERAMIC 1000PF-K/50V		D011102177101S		
C851D	nsp	C,CERAMIC 1000PF-K/50V		D011102177101S		
C852D	nsp	C,CERAMIC 1000PF-K/50V		D011102177101S		
C853D	nsp	C,CERAMIC 1000PF-K/50V		D011102177101S		
C854D	nsp	C,CERAMIC 0.1UF-K/50V		D011104177101S		
C855D	nsp	C,CERAMIC 0.1UF-K/50V		D011104177101S		
C856D	nsp	C,CERAMIC 0.1UF-K/50V		D011104177101S		
C857D	nsp	C,CERAMIC 0.1UF-K/50V		D011104177101S		
C858D	nsp	C,CERAMIC 0.1UF-K/50V		D011104177101S		
C859D	nsp	C,CERAMIC 0.1UF-K/50V		D011104177101S		
C860D	nsp	C,CERAMIC 0.1UF-K/50V		D011104177101S		
C861D	nsp	C,CERAMIC 0.1UF-K/50V		D011104177101S		
C862D	nsp	C,CERAMIC 0.01UF-K/50V		D011103177101S		
C863D	nsp	C,CERAMIC 100PF-J/50V		D011101167101S		
C864D	nsp	C,CERAMIC 4.7UF-K/10V		D011475572200S		
C865D	nsp	C,CERAMIC 5PF-C/50V		D010050107160S		
C866D	nsp	C,CERAMIC 5PF-C/50V		D010050107160S		
C871D	nsp	C,CERAMIC 0.01UF-K/50V		D011103177101S		
C873D	nsp	C,CERAMIC 0.01UF-K/50V		D011103177101S		
C875D	nsp	C,CERAMIC 4.7UF-K/10V		D011475572200S		
C876D	nsp	C,CERAMIC 0.01UF-K/50V		D011103177101S		
C877D	nsp	C,CERAMIC 0.1UF-K/50V		D011104177101S		
C878D	nsp	C,CERAMIC 0.1UF-K/50V		D011104177101S		
C879D	nsp	C,CERAMIC 0.1UF-K/50V		D011104177101S		
C880D	nsp	C,CERAMIC 0.01UF-K/50V		D011103177101S		
C881D	nsp	C,CERAMIC 0.01UF-K/50V		D011103177101S		
C882D	nsp	C,CERAMIC 6PF-D/50V		D010060117160S		
C883D	nsp	C,CERAMIC 6PF-D/50V		D010060117160S		
C884D	nsp	C,CERAMIC 0.1UF-K/50V		D011104577162S		
C885D	nsp	C,CERAMIC 0.022UF-Z/50V		D011223597160S		
C886D	nsp	C,CERAMIC 0.1UF-K/50V		D011104177101S		
C887D	nsp	C,FILM 0.12UF-J/63V		D020124078060S		
C888D	nsp	C,CERAMIC 0.01UF-K/50V		D011103177101S		
C889D	nsp	C,CERAMIC 100PF-J/50V		D011101167101S		
C890D	nsp	C,CERAMIC 0.01UF-K/50V		D011103177101S		
C891D	nsp	C,CERAMIC 0.01UF-K/50V		D011103177101S		
C892D	nsp	C,CERAMIC 4.7UF-K/10V		D011475572200S		
C893D	nsp	C,CERAMIC 0.1UF-K/50V		D011104177101S		
C895D	nsp	C,CERAMIC 0.1UF-K/50V		D011104177101S		
C896D	nsp	C,CERAMIC 0.01UF-K/50V		D011103177101S		
C897D	nsp	C,CERAMIC 0.1UF-K/50V		D011104177101S		
C898D	nsp	C,CERAMIC 0.1UF-K/50V		D011104177101S		
C899D	nsp	C,CERAMIC 100PF-J/50V		D011101167101S		
C900D	nsp	C,CERAMIC 4.7UF-K/10V		D011475572200S		
C901D	nsp	C,ELECT 100UF-MVG/6.3V		D050101081650S		
C902D	nsp	C,CERAMIC 0.1UF-K/50V		D011104177101S		
C903D	nsp	C,CERAMIC 0.1UF-K/50V		D011104177101S		
C904D	nsp	C,CERAMIC 5600PF-K/50V		D011562777160S		
C905D	nsp	C,CERAMIC 390PF-J/50V		D010391167160S		
C906D	nsp	C,CERAMIC 0.1UF-K/50V		D011104177101S		

Ref. No.	Part No.	Part Name	Remarks		Q'ty	New
C907D	nsp	C,CERAMIC 0.1UF-K/50V		D011104177101S		
C908D	nsp	C,ELECT 47UF-MVG/6.3V		D050470081460S		
C909D	nsp	C,CERAMIC 0.1UF-K/50V		D011104177101S		
C910D	nsp	C,ELECT 10UF-MVG/16V		D050100083460S		
C911D	nsp	C,CERAMIC 0.01UF-K/50V		D011103177101S		
C913D	nsp	C,ELECT 10UF-MVG/16V		D050100083460S		
C914D	nsp	C,CERAMIC 0.01UF-K/50V		D011103177101S		
C915D	nsp	C,ELECT 10UF-MVG/16V		D050100083460S		
OTHERS PARTS GROUP						
BD801	nsp	COIL,BEAD MB-160808		D340160800060S		
BD807D	nsp	COIL,BEAD MB-160808		D340160800060S		
BD808D-03	nsp	COIL,BEAD MB-160808		D340160800060S		
CB06	nsp	COIL,BEAD MB-160808		D340160800060S		
CN01	nsp	CN.WAFER 16P		L101100031610S		
CN802	nsp	CN.HOUSING 16P		L120912160010S		
CN803	nsp	CN.WAFER 16P		L101100031610S		
CN804	nsp	CN.HOUSING 15P		L120912150010S		
CN805	nsp	CN.HOUSING 08P		L120912080010S		
CP201	nsp	CN.WAFER 9P		L101220090000S		
CP404	nsp	CN.WAFER 4P		L101220040000S		
CP405	nsp	CN.WAFER 5P		L101220050000S		
CP904	nsp	CN.WAFER 6P		L101220060010S		
J806	nsp	R,CHIP THICK 0-J,1/16W		C20000006M101S		
JACK01-03	00D 963 0388 504	19PIN HDMI CONNECTOR		L109100190020S		
JACK04	nsp	CAM-D96 4PIN SMALL COCNNETOR		L109040000020S		
TP801	nsp	CN.WAFER 13P		L101530141310S		
X01	nsp	FCX-02(45.1584MHz)		00D3991055912		
X803D	nsp	FCX-03(16.660MHz)		00D3991091905		
X804D	nsp	FCX-03(24.576MHz)		00D3991053901		

VIDEO P.W.B. UNIT ASS'Y

Ref. No.	Part No.	Part Name	Remarks	Q'ty	New
SEMICONDUCTORS GROUP					
IC1301	00D 960 0175 200	IC BA7625		J171762500000S	
IC1302,1303	00D 963 0083 304	IC BA7626		J171762600000S	
IC1304	00D 960 0239 104	IC KIA7806API		J126780600130S	
IC1305-1307	00D 963 0148 401	IC LA7956		J171795600010S	
Q1301-1303	00D 960 0005 105	TR KTA1266Y		J5001266Y0050S	
Q1304,1305	00D 960 0005 202	TR KTC3198Y		J5023198Y0000S	
Q1306-1309	00D 963 0121 208	TR KRC107M		J6020107M0010S	
Q1310-1313	00D 960 0005 202	TR KTC3198Y		J5023198Y0000S	
Q1314-1317	00D 963 0121 208	TR KRC107M		J6020107M0010S	
D1301	00D 963 0355 401	D,SWITCHING KDS4148U		K005041480030S	
D1302-1305	00D 276 0401 905	D,SWITCHING 1SS133T		K000013300520S	
D1306,1307	00D 963 0355 401	D,SWITCHING KDS4148U		K005041480030S	
CAPACITORS GROUP					
C1301-1309	00D 960 9010 010	C,ELECT 4.7UF-M/50V		D0404R7087250S	
C1310	00D 963 9005 969	C,ELECT 4700UF-M/6.3V		D040472081000S	
C1311,1312	00D 960 0298 802	C,ELECT 470UF-M/6.3V		D040471081070S	
C1313-1315	00D 963 0311 607	C,ELECT 100UF-M/10V (Pb Free)		D040101082090S	
C1316-1321	00D 963 0293 602	C,ELECT 1UF-M/50V(Pb Free)		D040010087150S	
C1322	nsp	C,CERAMIC 0.022UF-K/25V		D011223777160S	
C1323	00D 963 0311 607	C,ELECT 100UF-M/10V (Pb Free)		D040101082090S	
C1324	nsp	C,CERAMIC 0.022UF-K/25V		D011223777160S	
C1326	nsp	C,CERAMIC 0.022UF-K/25V		D011223777160S	
C1328	00D 963 0234 205	C,ELECT 10UF-M/50V		D040100087070S	
C1329	00D 963 0234 506	C,ELECT 47UF-M/50V (Pb Free)		D040470087070S	
C1330	00D 963 0234 205	C,ELECT 10UF-M/50V		D040100087070S	
C1331-1339	00D 963 9005 862	C,ELECT 47UF-M/16V		D040470083080S	
C1340-1345	00D 963 9005 901	C,ELECT 470UF-M/10V		D040471082060S	
C1347	nsp	C,CERAMIC 0.047UF-Z/50V		D011473597160S	
C1348	00D 960 9009 924	C,ELECT 100UF-M/16V		D040101083070S	
C1349,1350	nsp	C,CERAMIC 0.047UF-Z/50V		D011473597160S	
C1351,1352	00D 963 0293 602	C,ELECT 1UF-M/50V(Pb Free)		D040010087150S	
OTHERS PARTS GROUP					
CN406	nsp	CN,WIRE 300MM/3P		L000301030060S	
CN1301	nsp	CN.WAFER 5P		L101220050010S	
CN1303	nsp	CN.WAFER 8P		L101100030810S	
CP1302	nsp	CN.WAFER 9P		L101100030910S	
JACK1301	00D 963 0218 001	TER,RCA 2PIN		G60122001000YS	
JACK1302	00D 963 0218 108	TER,RCA 3PIN		G60630401000YS	
JACK1303,1304	00D 963 0367 709	TER,RCA 6PIN		G603610D0032YS	
	nsp	HEAT SINK		2120044338010S	
	nsp	SCREW,TAP TITE +2S 3*8 B-TYPE ZNW/BH		B020030081B10S	

HDMI_PWR P.W.B. UNIT ASS'Y

Ref. No.	Part No.	Part Name	Remarks	Q'ty	New
SEMICONDUCTORS GROUP					
IC401H1	00D9630366500	IC KIA1117PI33		J126111733050S	
CAPACITORS GROUP					
C405H1	00D 963 0234 205	C,ELECT 10UF-M/50V		D040100087070S	
C406H1	00D9630233303	C,CERAMIC 0.01UF-M/16V		D005103773530S	
OTHERS PARTS GROUP					
CN404	nsp	CN,WIRE 300MM/4P		L000301040110S	
CP514	nsp	CN.WAFER 3P ANGLE		L102526803010S	

PARTS LIST OF P.W.B. UNIT



AVC-1508 JP MODEL

* 本表に "nsp" と記載されている部品は供給できません。

* Parts for which "nsp" is indicated on this table cannot be supplied.

* 本表に記載されている部品は、補修用部品のため製品に使用している部品とは一部、形状、寸法などが異なる場合があります。

* The parts listed below are for maintenance only, might differ from the parts used in the unit in appearances or dimensions.

MAIN P.W.B. UNIT ASS'Y

Ref. No.	Part No.	Part Name	Remarks	Q'ty	New
SEMICONDUCTORS GROUP					
IC110,111	00D 963 0218 807	IC BU4094BCF-E2		J040140940030S	
Q101	00D 960 0196 302	TR KTA1268BL		J5001268B0050S	
Q102-104	00D 960 0196 700	TR KTC3200BL		J5023200B0050S	
Q104C	00D 960 0196 506	TR KSC1845F		J5021845F0000S	
Q104FL	00D 960 0196 506	TR KSC1845F		J5021845F0000S	
Q104FR	00D 960 0196 506	TR KSC1845F		J5021845F0000S	
Q104SL	00D 960 0196 506	TR KSC1845F		J5021845F0000S	
Q104SR	00D 960 0196 506	TR KSC1845F		J5021845F0000S	
Q105	00D 960 0196 700	TR KTC3200BL		J5023200B0050S	
Q105C	00D 960 0196 603	TR KTC2874B		J502287400010S	
Q105FL	00D 960 0196 603	TR KTC2874B		J502287400010S	
Q105FR	00D 960 0196 603	TR KTC2874B		J502287400010S	
Q105SL	00D 960 0196 603	TR KTC2874B		J502287400010S	
Q105SR	00D 960 0196 603	TR KTC2874B		J502287400010S	
Q106	00D 960 0196 700	TR KTC3200BL		J5023200B0050S	
Q106C	00D 960 0196 205	TR KSA992F		J5000992F0050S	
Q106FL	00D 960 0196 205	TR KSA992F		J5000992F0050S	
Q106FR	00D 960 0196 205	TR KSA992F		J5000992F0050S	
Q106SL	00D 960 0196 205	TR KSA992F		J5000992F0050S	
Q106SR	00D 960 0196 205	TR KSA992F		J5000992F0050S	
Q107	00D 960 0196 700	TR KTC3200BL		J5023200B0050S	
Q107C	00D 960 0196 205	TR KSA992F		J5000992F0050S	
Q107FL	00D 960 0196 205	TR KSA992F		J5000992F0050S	
Q107FR	00D 960 0196 205	TR KSA992F		J5000992F0050S	
Q107SL	00D 960 0196 205	TR KSA992F		J5000992F0050S	
Q107SR	00D 960 0196 205	TR KSA992F		J5000992F0050S	
Q108	00D 960 0196 700	TR KTC3200BL		J5023200B0050S	
Q108C	00D 960 0196 506	TR KSC1845F		J5021845F0000S	
Q108FL	00D 960 0196 506	TR KSC1845F		J5021845F0000S	
Q108FR	00D 960 0196 506	TR KSC1845F		J5021845F0000S	
Q108SL	00D 960 0196 506	TR KSC1845F		J5021845F0000S	
Q108SR	00D 960 0196 506	TR KSC1845F		J5021845F0000S	
Q109,110	00D 960 0196 700	TR KTC3200BL		J5023200B0050S	
Q111	00D 960 0196 302	TR KTA1268BL		J5001268B0050S	
Q130	00D 960 0196 302	TR KTA1268BL		J5001268B0050S	
Q131,132	00D 963 0219 602	TR KRC106M		J6020106M0010S	
Q133-137	00D 960 0097 207	TR KRA102M		J6002202M0010S	
Q141SW	00D 963 0044 301	TR KTC2875B(MB)		J5222875B0010S	
Q142	00D 960 0196 700	TR KTC3200BL		J5023200B0050S	
Q142SW	00D 963 0044 301	TR KTC2875B(MB)		J5222875B0010S	
Q143,144	00D 960 0196 302	TR KTA1268BL		J5001268B0050S	
Q145	00D 960 0196 700	TR KTC3200BL		J5023200B0050S	
Q146,147	00D 960 0196 302	TR KTA1268BL		J5001268B0050S	
Q151	00D 960 0196 302	TR KTA1268BL		J5001268B0050S	
Q156	00D 960 0097 304	TR KRC102M		J6020102M0010S	
Q165	00D 960 0196 700	TR KTC3200BL		J5023200B0050S	
Q166-171	00D 960 0196 302	TR KTA1268BL		J5001268B0050S	

Ref. No.	Part No.	Part Name	Remarks		Q'ty	New
Q541	00D 963 0121 208	TR KRC107M		J6020107M0010S		
D101C	00D 963 0355 401	D,SWITCHING KDS4148U		K005041480030S		
D101FL	00D 963 0355 401	D,SWITCHING KDS4148U		K005041480030S		
D101FR	00D 963 0355 401	D,SWITCHING KDS4148U		K005041480030S		
D101SL	00D 963 0355 401	D,SWITCHING KDS4148U		K005041480030S		
D101SR	00D 963 0355 401	D,SWITCHING KDS4148U		K005041480030S		
D102C	00D 963 0355 401	D,SWITCHING KDS4148U		K005041480030S		
D102FL	00D 963 0355 401	D,SWITCHING KDS4148U		K005041480030S		
D102FR	00D 963 0355 401	D,SWITCHING KDS4148U		K005041480030S		
D102SL	00D 963 0355 401	D,SWITCHING KDS4148U		K005041480030S		
D102SR	00D 963 0355 401	D,SWITCHING KDS4148U		K005041480030S		
D105C	00D 963 0020 309	D,SWITCHING 1SS133T		K000013300520S		
D105FL	00D 963 0020 309	D,SWITCHING 1SS133T		K000013300520S		
D105FR	00D 963 0020 309	D,SWITCHING 1SS133T		K000013300520S		
D105SL	00D 963 0020 309	D,SWITCHING 1SS133T		K000013300520S		
D105SR	00D 963 0020 309	D,SWITCHING 1SS133T		K000013300520S		
D106,107	00D 963 0355 401	D,SWITCHING KDS4148U		K005041480030S		
D114,115	00D 960 0197 107	D,RECTIFIER BRIDGE KBPC604		K047604000020S		
D139	00D 963 0020 309	D,SWITCHING 1SS133T		K000013300520S		
D140,141	00D 963 0328 409	D,SWITCHING 1N4007		K000400700010S		
D142	00D 963 0355 401	D,SWITCHING KDS4148U		K005041480030S		
D143-152	00D 963 0020 309	D,SWITCHING 1SS133T		K000013300520S		
D153	00D 963 0355 401	D,SWITCHING KDS4148U		K005041480030S		
D154-157	00D 963 0020 309	D,SWITCHING 1SS133T		K000013300520S		
D541	00D 963 0355 401	D,SWITCHING KDS4148U		K005041480030S		
ZD101	00D 963 0058 601	D,ZENER MTZJ12B		K06012R044520S		
ZD101C	00D 963 0367 008	D,ZENER 0.2W 3.3V UDZ		K06603R34P400S		
ZD101FL	00D 963 0367 008	D,ZENER 0.2W 3.3V UDZ		K06603R34P400S		
ZD101FR	00D 963 0367 008	D,ZENER 0.2W 3.3V UDZ		K06603R34P400S		
ZD101SL	00D 963 0367 008	D,ZENER 0.2W 3.3V UDZ		K06603R34P400S		
ZD101SR	00D 963 0367 008	D,ZENER 0.2W 3.3V UDZ		K06603R34P400S		
ZD102C	00D 963 0367 008	D,ZENER 0.2W 3.3V UDZ		K06603R04P400S		
ZD102FL	00D 963 0367 008	D,ZENER 0.2W 3.3V UDZ		K06603R04P400S		
ZD102FR	00D 963 0367 008	D,ZENER 0.2W 3.3V UDZ		K06603R04P400S		
ZD102SL	00D 963 0367 008	D,ZENER 0.2W 3.3V UDZ		K06603R04P400S		
ZD102SR	00D 963 0367 008	D,ZENER 0.2W 3.3V UDZ		K06603R04P400S		
ZD105	00D 960 0095 500	D,ZENER MTZJ5.1B		K06005R144520S		
RESISTORS GROUP						
R101	00D 963 0337 801	R,METAL FILM 100-J,2W		C060010166520S		
R103	00D 963 9005 639	R,METAL FILM 100-J,1W		C060010165060S		
R104	00D 963 0215 907	R,METAL FILM 4.7-J,1W		C0604R7065050S		
R104C	00D 963 9006 285	R,FIXED 1WJ-5.6K		N113135656220S		
R104FL	00D 963 9006 285	R,FIXED 1WJ-5.6K		N113135656220S		
R104FR	00D 963 9006 285	R,FIXED 1WJ-5.6K		N113135656220S		
R104SL	00D 963 9006 285	R,FIXED 1WJ-5.6K		N113135656220S		
R104SR	00D 963 9006 285	R,FIXED 1WJ-5.6K		N113135656220S		
R105	00D 963 0232 906	R,METAL FILM 47K-F,1/4W		C060047343530S		
R105C	00D 963 9006 285	R,FIXED 1WJ-5.6K		N113135656220S		
R105FL	00D 963 9006 285	R,FIXED 1WJ-5.6K		N113135656220S		
R105FR	00D 963 9006 285	R,FIXED 1WJ-5.6K		N113135656220S		
R105SL	00D 963 9006 285	R,FIXED 1WJ-5.6K		N113135656220S		
R105SR	00D 963 9006 285	R,FIXED 1WJ-5.6K		N113135656220S		

Ref. No.	Part No.	Part Name	Remarks		Q'ty	New
R106C	00D 963 0215 907	R,METAL FILM 4.7-J,1W		C0604R7065050S		
R106FL	00D 963 0215 907	R,METAL FILM 4.7-J,1W		C0604R7065050S		
R106FR	00D 963 0215 907	R,METAL FILM 4.7-J,1W		C0604R7065050S		
R106SL	00D 963 0215 907	R,METAL FILM 4.7-J,1W		C0604R7065050S		
R106SR	00D 963 0215 907	R,METAL FILM 4.7-J,1W		C0604R7065050S		
R107C	00D 963 0215 907	R,METAL FILM 4.7-J,1W		C0604R7065050S		
R107FL	00D 963 0215 907	R,METAL FILM 4.7-J,1W		C0604R7065050S		
R107FR	00D 963 0215 907	R,METAL FILM 4.7-J,1W		C0604R7065050S		
R107SL	00D 963 0215 907	R,METAL FILM 4.7-J,1W		C0604R7065050S		
R107SR	00D 963 0215 907	R,METAL FILM 4.7-J,1W		C0604R7065050S		
R108C	00D 963 0345 903	R,FIXED 2WJ-0.47		N113136647820S		
R108FL	00D 963 0345 903	R,FIXED 2WJ-0.47		N113136647820S		
R108FR	00D 963 0345 903	R,FIXED 2WJ-0.47		N113136647820S		
R108SL	00D 963 0345 903	R,FIXED 2WJ-0.47		N113136647820S		
R108SR	00D 963 0345 903	R,FIXED 2WJ-0.47		N113136647820S		
R109C	00D 963 0345 903	R,FIXED 2WJ-0.47		N113136647820S		
R109FL	00D 963 0345 903	R,FIXED 2WJ-0.47		N113136647820S		
R109FR	00D 963 0345 903	R,FIXED 2WJ-0.47		N113136647820S		
R109SL	00D 963 0345 903	R,FIXED 2WJ-0.47		N113136647820S		
R109SR	00D 963 0345 903	R,FIXED 2WJ-0.47		N113136647820S		
R110C	00D 963 0345 903	R,FIXED 2WJ-0.47		N113136647820S		
R110FL	00D 963 0345 903	R,FIXED 2WJ-0.47		N113136647820S		
R110FR	00D 963 0345 903	R,FIXED 2WJ-0.47		N113136647820S		
R110SL	00D 963 0345 903	R,FIXED 2WJ-0.47		N113136647820S		
R110SR	00D 963 0345 903	R,FIXED 2WJ-0.47		N113136647820S		
R111C	00D 963 0345 903	R,FIXED 2WJ-0.47		N113136647820S		
R111FL	00D 963 0345 903	R,FIXED 2WJ-0.47		N113136647820S		
R111FR	00D 963 0345 903	R,FIXED 2WJ-0.47		N113136647820S		
R111SL	00D 963 0345 903	R,FIXED 2WJ-0.47		N113136647820S		
R111SR	00D 963 0345 903	R,FIXED 2WJ-0.47		N113136647820S		
R117,118	00D 963 0144 502	R,CEMENT 0.1-J 5W		C141R10069000S		
R118C	00D 963 9006 256	R,FIXED 1WJ-10		N113135610020S		
R118FL	00D 963 9006 256	R,FIXED 1WJ-10		N113135610020S		
R118FR	00D 963 9006 256	R,FIXED 1WJ-10		N113135610020S		
R118SL	00D 963 9006 256	R,FIXED 1WJ-10		N113135610020S		
R118SR	00D 963 9006 256	R,FIXED 1WJ-10		N113135610020S		
R119C	00D 963 9006 256	R,FIXED 1WJ-10		N113135610020S		
R119FL	00D 963 9006 256	R,FIXED 1WJ-10		N113135610020S		
R119FR	00D 963 9006 256	R,FIXED 1WJ-10		N113135610020S		
R119SL	00D 963 9006 256	R,FIXED 1WJ-10		N113135610020S		
R119SR	00D 963 9006 256	R,FIXED 1WJ-10		N113135610020S		
R127C	00D 963 9005 642	R,METAL FILM 1.2K-J,1W		C060012265050S		
R127FL	00D 963 9005 642	R,METAL FILM 1.2K-J,1W		C060012265050S		
R127FR	00D 963 9005 642	R,METAL FILM 1.2K-J,1W		C060012265050S		
R127SL	00D 963 9005 642	R,METAL FILM 1.2K-J,1W		C060012265050S		
R127SR	00D 963 9005 642	R,METAL FILM 1.2K-J,1W		C060012265050S		
R132C	00D 960 9010 719	R,METAL FILM 47-J,1W		C060047065060S		
R132FL	00D 960 9010 719	R,METAL FILM 47-J,1W		C060047065060S		
R132FR	00D 960 9010 719	R,METAL FILM 47-J,1W		C060047065060S		
R132SL	00D 960 9010 719	R,METAL FILM 47-J,1W		C060047065060S		
R132SR	00D 960 9010 719	R,METAL FILM 47-J,1W		C060047065060S		
R147-149	00D 963 9005 642	R,METAL FILM 1.2K-J,1W		C060012265050S		
VR101C	00D 960 0221 109	VR,SEMI CARBON EVN-DJAA03B		C541102115000S		
VR101FL	00D 960 0221 109	VR,SEMI CARBON EVN-DJAA03B		C541102115000S		
VR101FR	00D 960 0221 109	VR,SEMI CARBON EVN-DJAA03B		C541102115000S		

Ref. No.	Part No.	Part Name	Remarks		Q'ty	New
VR101SL	00D 960 0221 109	VR,SEMI CARBON EVN-DJAA03B		C541102115000S		
VR101SR	00D 960 0221 109	VR,SEMI CARBON EVN-DJAA03B		C541102115000S		
CAPACITORS GROUP						
C101	00D 963 9005 804	C,ELECT 100UF-M/25V		D040101084060S		
C101C	00D 963 0234 506	C,ELECT 47UF-M/50V (Pb Free)		D040470087070S		
C101FL	00D 963 0234 506	C,ELECT 47UF-M/50V (Pb Free)		D040470087070S		
C101FR	00D 963 0234 506	C,ELECT 47UF-M/50V (Pb Free)		D040470087070S		
C101SL	00D 963 0234 506	C,ELECT 47UF-M/50V (Pb Free)		D040470087070S		
C101SR	00D 963 0234 506	C,ELECT 47UF-M/50V (Pb Free)		D040470087070S		
C102	00D 963 0224 503	C,ELECT 22UF-M/50V		D040220087060S		
C102C	00D 963 0234 205	C,ELECT 10UF-M/50V		D040100087070S		
C102FL	00D 960 9010 133	C,ELECT 220UF-M/35V		D040221085060S		
C102FR	00D 960 9010 133	C,ELECT 220UF-M/35V		D040221085060S		
C102SL	00D 963 0234 205	C,ELECT 10UF-M/50V		D040100087070S		
C102SR	00D 963 0234 205	C,ELECT 10UF-M/50V		D040100087070S		
C103	00D 963 9006 557	C,ELECT 220UF-M/6.3V		D040221081060S		
C103C	00D 963 9003 084	C,CERAMIC 100PF-K/500V		D00410106D050S		
C103FL	00D 963 9003 084	C,CERAMIC 100PF-K/500V		D00410106D050S		
C103FR	00D 963 9003 084	C,CERAMIC 100PF-K/500V		D00410106D050S		
C103SL	00D 963 9003 084	C,CERAMIC 100PF-K/500V		D00410106D050S		
C103SR	00D 963 9003 084	C,CERAMIC 100PF-K/500V		D00410106D050S		
C104	00D 963 9006 557	C,ELECT 220UF-M/6.3V		D040221081060S		
C104C	00D 963 9003 084	C,CERAMIC 100PF-K/500V		D00410106D050S		
C104FL	00D 963 9003 084	C,CERAMIC 100PF-K/500V		D00410106D050S		
C104FR	00D 963 9003 084	C,CERAMIC 100PF-K/500V		D00410106D050S		
C104SL	00D 963 9003 084	C,CERAMIC 100PF-K/500V		D00410106D050S		
C104SR	00D 963 9003 084	C,CERAMIC 100PF-K/500V		D00410106D050S		
C105	00D 963 9006 557	C,ELECT 220UF-M/6.3V		D040221081060S		
C105C	nsp	C,CERAMIC 0.022UF-Z/50V		D011223597160S		
C105FL	nsp	C,CERAMIC 0.022UF-Z/50V		D011223597160S		
C105FR	nsp	C,CERAMIC 0.022UF-Z/50V		D011223597160S		
C105SL	nsp	C,CERAMIC 0.022UF-Z/50V		D011223597160S		
C105SR	nsp	C,CERAMIC 0.022UF-Z/50V		D011223597160S		
C106	00D 963 0293 709	C,ELECT 100UF-M/10V		D040101082070S		
C107	nsp	C,CERAMIC 0.01UF-K/50V		D011103777160S		
C107C	00D 963 9003 097	C,FILM 0.1UF-K/250V		D02010407H080S		
C107FL	00D 963 9003 097	C,FILM 0.1UF-K/250V		D02010407H080S		
C107FR	00D 963 9003 097	C,FILM 0.1UF-K/250V		D02010407H080S		
C107SL	00D 963 9003 097	C,FILM 0.1UF-K/250V		D02010407H080S		
C107SR	00D 963 9003 097	C,FILM 0.1UF-K/250V		D02010407H080S		
C108	00D 963 0149 400	CAP.E.GENERIC 10000UF/63V		N211210388110S		
C108C	00D 963 9006 544	C,ELECT 22UF-M/25V		D040220084050S		
C108FL	00D 963 9006 544	C,ELECT 22UF-M/25V		D040220084050S		
C108FR	00D 963 9006 544	C,ELECT 22UF-M/25V		D040220084050S		
C108SL	00D 963 9006 544	C,ELECT 22UF-M/25V		D040220084050S		
C108SR	00D 963 9006 544	C,ELECT 22UF-M/25V		D040220084050S		
C109	00D 963 0149 400	CAP.E.GENERIC 10000UF/63V		N211210388110S		
C109C	00D 963 0234 205	C,ELECT 10UF-M/50V		D040100087070S		
C109FL	00D 963 0234 205	C,ELECT 10UF-M/50V		D040100087070S		
C109FR	00D 963 0234 205	C,ELECT 10UF-M/50V		D040100087070S		
C109SL	00D 963 0234 205	C,ELECT 10UF-M/50V		D040100087070S		
C109SR	00D 963 0234 205	C,ELECT 10UF-M/50V		D040100087070S		
C110	00D 963 9003 097	C,FILM 0.1UF-K/250V		D02010407H080S		
C110C	00D 963 0338 208	C,CERAMIC 470PF-K/500V		D00447127D050S		

Ref. No.	Part No.	Part Name	Remarks		Q'ty	New
C110FL	00D 963 0338 208	C,CERAMIC 470PF-K/500V		D00447127D050S		
C110FR	00D 963 0338 208	C,CERAMIC 470PF-K/500V		D00447127D050S		
C110SL	00D 963 0338 208	C,CERAMIC 470PF-K/500V		D00447127D050S		
C110SR	00D 963 0338 208	C,CERAMIC 470PF-K/500V		D00447127D050S		
C111	00D 963 9003 097	C,FILM 0.1UF-K/250V		D02010407H080S		
C111C	00D 963 0367 101	C,CERAMIC 220PF-J/500V		D00422106D05CS		
C111FL	00D 963 0367 101	C,CERAMIC 220PF-J/500V		D00422106D05CS		
C111FR	00D 963 0367 101	C,CERAMIC 220PF-J/500V		D00422106D05CS		
C111SL	00D 963 0367 101	C,CERAMIC 220PF-J/500V		D00422106D05CS		
C111SR	00D 963 0367 101	C,CERAMIC 220PF-J/500V		D00422106D05CS		
C112	00D 963 9003 097	C,FILM 0.1UF-K/250V		D02010407H080S		
C112C	00D 963 9003 194	C,FILM 0.0022UF-J/100V		D02022206C060S		
C112FL	00D 963 9003 194	C,FILM 0.0022UF-J/100V		D02022206C060S		
C112FR	00D 963 9003 194	C,FILM 0.0022UF-J/100V		D02022206C060S		
C112SL	00D 963 9003 194	C,FILM 0.0022UF-J/100V		D02022206C060S		
C112SR	00D 963 9003 194	C,FILM 0.0022UF-J/100V		D02022206C060S		
C113C	00D 963 0293 709	C,ELECT 100UF-M/10V		D040101082070S		
C113FL	00D 960 9010 133	C,ELECT 220UF-M/35V		D040221085060S		
C113FR	00D 960 9010 133	C,ELECT 220UF-M/35V		D040221085060S		
C113SL	00D 963 0293 709	C,ELECT 100UF-M/10V		D040101082070S		
C113SR	00D 963 0293 709	C,ELECT 100UF-M/10V		D040101082070S		
C114	00D 963 9003 097	C,FILM 0.1UF-K/250V		D02010407H080S		
C114C	00D 963 0216 100	C,CERAMIC 33PF-J/500V		D00033006D050S		
C114FL	00D 963 0216 100	C,CERAMIC 33PF-J/500V		D00033006D050S		
C114FR	00D 963 0216 100	C,CERAMIC 33PF-J/500V		D00033006D050S		
C114SL	00D 963 0216 100	C,CERAMIC 33PF-J/500V		D00033006D050S		
C114SR	00D 963 0216 100	C,CERAMIC 33PF-J/500V		D00033006D050S		
C115	00D 963 9003 097	C,FILM 0.1UF-K/250V		D02010407H080S		
C115SW	00D 963 9006 544	C,ELECT 22UF-M/25V		D040220084050S		
C117-120	nsp	C,CERAMIC 0.1UF-K/50V		D011104577160S		
C141SW1	00D 963 0234 205	C,ELECT 10UF-M/50V		D040100087070S		
C142SW1	nsp	C,CERAMIC 100PF-J/50V		D010101167160S		
C161	00D 963 0234 205	C,ELECT 10UF-M/50V		D040100087070S		
C162,163	nsp	C,CERAMIC 0.01UF-K/50V		D011103777160S		
C164-167	nsp	C,CERAMIC 100PF-J/50V		D010101167160S		
C168-172	00D 963 0244 606	C,ELECT 0.1UF-M/50V (Pb Free)		D040R10087080S		
C177	nsp	C,CERAMIC 0.01UF-K/50V		D011103777160S		
C178,179	00D 960 9010 010	C,ELECT 4.7UF-M/50V		D0404R7087250S		
C180,181	nsp	C,CERAMIC 0.01UF-K/50V		D011103777160S		
C182	00D 963 0324 005	C,ELECT 100UF-M/100V		D04010108C240S		
C183	00D 963 0293 602	C,ELECT 1UF-M/50V (Pb Free)		D040010087150S		
C190	00D 960 9010 010	C,ELECT 4.7UF-M/50V		D0404R7087250S		
C221L	nsp	C,CERAMIC 330PF-J/50V		D010331167160S		
C221R	nsp	C,CERAMIC 330PF-J/50V		D010331167160S		
C222L	00D 963 0234 205	C,ELECT 10UF-M/50V		D040100087070S		
C222R	00D 963 0234 205	C,ELECT 10UF-M/50V		D040100087070S		
OTHERS PARTS GROUP						
BKT101	nsp	SHIELD PLATE GND		3070045526010S		
CN101	nsp	CN,WIRE 14P		L000111140010S		
CN103	nsp	CN,WIRE 7P		L000141070020S		
CN201	nsp	CN,WIRE 4P		L000700100020S		
CN511	nsp	CN,WIRE 60MM/9P		L000600090020S		
CN704	nsp	CN,WIRE 15P		L000600150030S		

Ref. No.	Part No.	Part Name	Remarks		Q'ty	New
CP103	nsp	CN.WAFER 2.5MM 5267-03A 3P		L102526700300S		
CP104	nsp	CN.WAFER 3CKT		L108353280360S		
CP105,106	nsp	CN.WAFER 5P		L101100040510S		
CP107	nsp	CN.WAFER 3P		L102526700300S		
CP108	nsp	CN.WAFER 17P		L101100041710S		
CP541	nsp	CN.WAFER 3P		L101220030000S		
GND101	nsp	TERMINAL EARTH		3790040886000S		
JACK221	90M -YT 0046 40R	TER,RCA 2PIN		G601207AE020YS		
JACK222		TER,RCA 1PIN		G600107A0000YS		
L101C	00D 963 0049 005	COIL INDUCTOR 0.5UH		D330R50000000S		
L101FL	00D 963 0049 005	COIL INDUCTOR 0.5UH		D330R50000000S		
L101FR	00D 963 0049 005	COIL INDUCTOR 0.5UH		D330R50000000S		
L101SL	00D 963 0049 005	COIL INDUCTOR 0.5UH		D330R50000000S		
L101SR	00D 963 0049 005	COIL INDUCTOR 0.5UH		D330R50000000S		
RLY541	00D 963 0218 506	RELAY BC3-24 24V 2A		G680240202040S		
TP101-105	nsp	CN.WAFER 3P		L101530140310S		
JP108	00D 963 0223 009	R,CHIP THICK 0-J,1/16W		C20000006M160S		
JP347	nsp	C,CERAMIC 0.1UF-K/50V		D011104577160S		
JP352	00D 96 30223 009	R,CHIP THICK 0-J,1/16W		C20000006M160S		

FRONT P.W.B. UNIT ASS'Y

	Ref. No.	Part No.	Part Name	Remarks		Q'ty	New
SEMICONDUCTORS GROUP							
	IC301	00D 963 0074 504	IC BU2090F-E2		J044209000010S		
	IC302	00D 262 3758 009	LC87F6D64A-QFP-E		J127876160010S		
▲	IC303	00D 960 0195 808	IC ICP-N15		J120001500030S		
	IC305	00D 963 0024 004	IC NJM2068M		J121206800020S		
	Q301-303	00D 963 0120 704	TR KRA102S		J520010200210S		
	Q304	00D 963 0121 606	TR KRC107S		J522107S00210S		
	Q305	00D 963 0102 803	TR 2SA933S		J5000933S0050S		
	Q306	00D 963 0120 801	TR KRC102S		J522010200210S		
	Q307-309	00D 963 0120 704	TR KRA102S		J520010200210S		
	Q310,311	00D 963 0120 801	TR KRC102S		J522010200210S		
	Q312	00D 960 0133 103	TR KSA916Y		J5000916Y0050S		
	Q542-546	00D 963 0121 208	TR KRC107M		J6020107M0010S		
	D301,302	00D 963 0020 309	D,SWITCHING 1SS133T		K000013300520S		
	D303	00D 963 0355 401	D,SWITCHING KDS4148U		K005041480030S		
	D304	00D 963 0020 309	D,SWITCHING 1SS133T		K000013300520S		
	D305-311	00D 963 0355 401	D,SWITCHING KDS4148U		K005041480030S		
	D312	00D 963 0328 409	D,SWITCHING 1N4007		K000400700010S		
	D315,316	00D 963 0355 401	D,SWITCHING KDS4148U		K005041480030S		
	D542	00D 963 0020 309	D,SWITCHING 1SS133T		K000013300520S		
	D543-545	00D 963 0355 401	D,SWITCHING KDS4148U		K005041480030S		
	D546	00D 963 0020 309	D,SWITCHING 1SS133T		K000013300520S		
	ZD302-308	00D 960 0095 500	D,ZENER MTZJ5.1B		K06005R144520S		
	ZD309	00D 960 0095 801	D,ZENER MTZJ6.8B		K06006R844520S		
	ZD310,311	00D 963 0046 202	D,ZENER MTZJ18B		K06018R044520S		
	ZD312,313	00D 960 0095 500	D,ZENER MTZJ5.1B		K06005R144520S		
	LED302-309	00D 960 0197 204	LED PI5-RD/HL50RDRF4T		K500052015010S		
	LED310	00D 963 0366 108	LED BL-BEG204-L 5PI		K500052004010S		
	LED311	00D 963 0148 605	LED SML1216W		K500052600030S		
	LED313	00D 960 0197 204	LED PI5-RD/HL50RDRF4T		K500052015010S		
	FL301	00D 963 0257 305	DISPLAY,FLT HNA-16SM13T		K530161300020S		
RESISTORS GROUP							
	R372	00D 963 0215 907	R,METAL FILM 4.7-J,1W		C0604R7065050S		
	R378,379	00D 960 9009 270	R,METAL FILM 470-J,2W		C060047166520S		
	R501	00D 960 9003 700	R,METAL FILM 10-J,1/4W		C060010063050S		
	RP1-38	00D 963 0353 005	R,CHIP THICK 56K-J,1/16W		C20005636M160S		
	RG1-16	00D 963 0353 005	R,CHIP THICK 56K-J,1/16W		C20005636M160S		
CAPACITORS GROUP							
	C301,302	nsp	C,CERAMIC 100PF-J/50V		D010101167160S		
	C303	nsp	C,CERAMIC 0.022UF-K/25V		D011223777160S		
	C304	00D 963 9005 862	C,ELECT 47UF-M/16V		D040470083080S		
	C305	nsp	C,CERAMIC 100PF-J/50V		D010101167160S		
	C306	nsp	C,CERAMIC 0.047UF-Z/50V		D011473597160S		
	C307	00D 963 9005 862	C,ELECT 47UF-M/16V		D040470083080S		

Ref. No.	Part No.	Part Name	Remarks		Q'ty	New
C308	nsp	C,CERAMIC 0.01UF-K/50V		D011103777160S		
C309,310	00D 963 0293 602	C,ELECT 1UF-M/50V (Pb Free)		D040010087150S		
C311	00D 963 0233 303	C,CERAMIC 0.01UF-M/16V		D005103773530S		
C312	00D 963 9005 862	C,ELECT 47UF-M/16V		D040470083080S		
C315	nsp	C,CERAMIC 150PF-J/50V		D010151167160S		
C316,317	nsp	C,CERAMIC 330PF-J/50V		D010331167160S		
C318	nsp	C,CERAMIC 100PF-J/50V		D010101167160S		
C319,320	nsp	C,CERAMIC 0.01UF-K/50V		D011103777160S		
C321,322	00D 963 0233 303	C,CERAMIC 0.01UF-M/16V		D005103773530S		
C323-325	00D 963 0293 602	C,ELECT 1UF-M/50V (Pb Free)		D040010087150S		
C326	00D 963 9005 862	C,ELECT 47UF-M/16V		D040470083080S		
C327,328	nsp	C,CERAMIC 0.1UF-K/50V		D011104577160S		
C329	nsp	C,FILM 0.1UF-J/100V		D02010406C060S		
C330	00D 963 0021 900	C,FILM 0.047UF-J/100V		D02047306C060S		
C331	00D 963 0234 205	C,ELECT 10UF-M/50V		D040100087070S		
C332	nsp	C,CERAMIC 150PF-J/50V		D010151167160S		
C333	00D 963 0293 602	C,ELECT 1UF-M/50V (Pb Free)		D040010087150S		
C334	00D 963 0021 900	C,FILM 0.047UF-J/100V		D02047306C060S		
C335	nsp	C,CERAMIC 0.1UF-K/50V		D011104577160S		
C336	nsp	C,CERAMIC 100PF-J/50V		D010101167160S		
C337	00D 963 0293 602	C,ELECT 1UF-M/50V (Pb Free)		D040010087150S		
C338	nsp	C,CERAMIC 0.01UF-K/50V		D011103777160S		
C339	nsp	C,CERAMIC 100PF-J/50V		D010101167160S		
C340	nsp	C,CERAMIC 1000PF-K/50V		D011102777160S		
C341,342	nsp	C,CERAMIC 100PF-J/50V		D010101167160S		
C343	00D 963 0020 202	C,CERAMIC 0.1UF-Z/50V		D005104597530S		
C344,345	00D 963 0233 206	C,CERAMIC 0.001UF-K/50V		D005102177530S		
C346-349	nsp	C,CERAMIC 0.01UF-K/50V		D011103777160S		
C350	00D 963 0021 900	C,FILM 0.047UF-J/100V		D02047306C060S		
C351	00D 963 0293 602	C,ELECT 1UF-M/50V (Pb Free)		D040010087150S		
C352	00D 963 0234 205	C,ELECT 10UF-M/50V		D040100087070S		
C353,354	00D 963 0293 602	C,ELECT 1UF-M/50V (Pb Free)		D040010087150S		
C355	nsp	C,ELECT 470UF-M/63V		D040471088010S		
C356	00D 963 9003 097	C,FILM 0.1UF-K/250V		D02010407H080S		
C357,358	nsp	C,CERAMIC 0.047UF-Z/50V		D011473597160S		
C541	nsp	C,CERAMIC 2200PF-K/50V		D011222777160S		
C541FL	00D 963 0024 703	C,FILM 0.01UF-J/100V		D02010306C060S		
C542	nsp	C,CERAMIC 2200PF-K/50V		D011222777160S		
C542FR	00D 963 0024 703	C,FILM 0.01UF-J/100V		D02010306C060S		
C543	nsp	C,CERAMIC 2200PF-K/50V		D011222777160S		
C543FL	00D 963 0024 703	C,FILM 0.01UF-J/100V		D02010306C060S		
C544	nsp	C,CERAMIC 2200PF-K/50V		D011222777160S		
C544FR	00D 963 0024 703	C,FILM 0.01UF-J/100V		D02010306C060S		
C545	nsp	C,CERAMIC 2200PF-K/50V		D011222777160S		
C545C	00D 963 0024 703	C,FILM 0.01UF-J/100V		D02010306C060S		
C546	nsp	C,CERAMIC 2200PF-K/50V		D011222777160S		
C546SL	00D 963 0024 703	C,FILM 0.01UF-J/100V		D02010306C060S		
C547	nsp	C,CERAMIC 2200PF-K/50V		D011222777160S		
C547SR	00D 963 0024 703	C,FILM 0.01UF-J/100V		D02010306C060S		
C548	nsp	C,CERAMIC 2200PF-K/50V		D011222777160S		
C548SBL	00D 963 0024 703	C,FILM 0.01UF-J/100V		D02010306C060S		
C549	nsp	C,CERAMIC 2200PF-K/50V		D011222777160S		
C549SBR	00D 963 0024 703	C,FILM 0.01UF-J/100V		D02010306C060S		

Ref. No.	Part No.	Part Name	Remarks		Q'ty	New
OTHERS PARTS GROUP						
	BD301-307	nsp	COIL,BEAD MB-160808		D340160800060S	
	CN102	nsp	CN,WIRE 270,170MM/4P		L000271040040S	
	CN301	nsp	CN,WIRE 2P		L000401020050S	
	CN302A	nsp	CN,WIRE 5P		L000450050010S	
	CN303A	nsp	CN,WIRE 8P		L000450080010S	
	CN304	nsp	CN,WIRE 3P		L000500030050S	
	CN305	nsp	CN,WIRE 10P		L000700100030S	
	CN541	nsp	CN,WIRE 3P		L000251030080S	
	CP101	nsp	CN.WAFER 10P		L102526701000S	
	CP103	nsp	CN.WAFER 7P		L101220070000S	
	CP105	nsp	CN.WAFER 4P ANGLE		L102526800400S	
	CP301B	00D 963 0368 506	CN.FPC 35P		L131103500010S	
	CP302	nsp	CN.WAFER 3P ANGLE		L102526803010S	
	CP304	nsp	CN.WAFER 3P		L101220030000S	
	CP305	nsp	CN.WAFER 10P		L101220100010S	
	CP306	nsp	CN.WAFER 3P		L101220030010S	
	G301	nsp	RING,TER WIRE 120MM/1P		8410121010060S	
	G302	nsp	RING,TER WIRE 120MM/1P		8410121010110S	
	G304	nsp	RING,TER WIRE 80MM/2P		8410800020040S	
	JACK301	00D 963 0367 802	JACK,D3.5 EARPHONE		G401PJ354H40YS	
	JACK304	00D 963 0146 403	TER,RCA 3PIN		G606308HG110Y S	
	JACK501,502	00D 963 0146 607	TER,BOARD SCREW 8P		G614801A0200YS	
	JACK503	00D 963 0158 608	TER,BOARD SCREW 2P		G611201A0200YS	
	JK302	00D 963 0294 708	JACK,D6.5 PHONE		G402PJ612AG0YS	
	L302	nsp	COIL INDUCTOR 10UH		D330100700520S	
	L303	nsp	COIL INDUCTOR 100UH		D330101001020S	
	RLY541	00D 963 0366 201	RELAY G5PA-28-MC 24V 5A		G680240502030S	
	RLY543-546	00D 963 0366 201	RELAY G5PA-28-MC 24V 5A		G680240502030S	
	RMC301	00D 963 0217 808	MODULE,REMOCON NJL34H380A		E940343800010S	
△	SW301	00D 963 0145 802	SW,PUSH SDDL-005-S(C-UL)		G000122006060S	
	SW301A	00D 963 0095 305	SW,TACT SKHV10910D01		G180040500010S	
	SW301C	00D 963 0095 305	SW,TACT SKHV10910D01		G180040500010S	
	SW302A	00D 963 0095 305	SW,TACT SKHV10910D01		G180040500010S	
	SW302B	00D 963 0095 305	SW,TACT SKHV10910D01		G180040500010S	
	SW302C	00D 963 0095 305	SW,TACT SKHV10910D01		G180040500010S	
	SW303A	00D 963 0095 305	SW,TACT SKHV10910D01		G180040500010S	
	SW303B	00D 963 0095 305	SW,TACT SKHV10910D01		G180040500010S	
	SW303C	00D 963 0095 305	SW,TACT SKHV10910D01		G180040500010S	
	SW304A	00D 963 0095 305	SW,TACT SKHV10910D01		G180040500010S	
	SW304B	00D 963 0095 305	SW,TACT SKHV10910D01		G180040500010S	
	SW304C	00D 963 0095 305	SW,TACT SKHV10910D01		G180040500010S	
	SW305A	00D 963 0095 305	SW,TACT SKHV10910D01		G180040500010S	
	SW305B	00D 963 0095 305	SW,TACT SKHV10910D01		G180040500010S	
	SW305C	00D 963 0095 305	SW,TACT SKHV10910D01		G180040500010S	

Ref. No.	Part No.	Part Name	Remarks		Q'ty	New
SW306A	00D 963 0095 305	SW,TACT SKHV10910D01		G180040500010S		
SW306B	00D 963 0095 305	SW,TACT SKHV10910D01		G180040500010S		
SW306C	00D 963 0095 305	SW,TACT SKHV10910D01		G180040500010S		
SW307A	00D 963 0095 305	SW,TACT SKHV10910D01		G180040500010S		
SW307B	00D 963 0095 305	SW,TACT SKHV10910D01		G180040500010S		
SW307C	00D 963 0095 305	SW,TACT SKHV10910D01		G180040500010S		
SW308A	00D 963 0095 305	SW,TACT SKHV10910D01		G180040500010S		
SW308B	00D 963 0095 305	SW,TACT SKHV10910D01		G180040500010S		
SW308C	00D 963 0095 305	SW,TACT SKHV10910D01		G180040500010S		
SW309A	00D 963 0095 305	SW,TACT SKHV10910D01		G180040500010S		
SW310	00D 963 0095 305	SW,TACT SKHV10910D01		G180040500010S		
VEC203	00D 963 0300 401	SW,ENCODER EC11B20C2		G121112020000S		
VEC301	00D 963 0095 208	SW,ENCODER EC16B24SO		G121162400070S		
VEC303	00D 963 0095 208	SW,ENCODER EC16B24SO		G121162400070S		
	nsp	HOLDER FLT		4320200026000S		

INPUT P.W.B. UNIT ASS'Y

Ref. No.	Part No.	Part Name	Remarks	Q'ty	New
SEMICONDUCTORS GROUP					
IC700	00D 963 0366 304	IC R2A15215FP		J084152150010S	
IC702	00D 963 0024 004	IC NJM2068M		J121206800020S	
IC705-718	00D 963 0024 004	IC NJM2068M		J121206800020S	
Q700,701	00D 960 0196 807	TR 2SK117Y		J5441170Y0050S	
Q702	00D 963 0120 704	TR KRA102S		J520010200210S	
Q703	00D 960 0285 006	TR KRC104S		J522104S00210S	
D700,701	00D 963 0355 401	D,SWITCHING KDS4148U		K005041480030S	
ZD700,701	00D 960 0222 603	D,ZENER MTZJ7.5A		K06007R544530S	
RESISTORS GROUP					
R706-709	00D 963 9005 639	R,METAL FILM 100-J,1W		C060010165060S	
R791VC	nsp	R,METAL FILM 120-J,1W		C060012165060S	
R791VE	nsp	R,METAL FILM 120-J,1W		C060012165060S	
CAPACITORS GROUP					
C700	00D 963 0234 205	C,ELECT 10UF-M/50V		D040100087070S	
C702SW	00D 960 9010 010	C,ELECT 4.7UF-M/50V		D0404R7087250S	
C703C	nsp	C,CERAMIC 0.047UF-Z/50V		D011473597160S	
C703SW	nsp	C,CERAMIC 0.047UF-Z/50V		D011473597160S	
C704,705	00D 963 9005 875	C,ELECT 47UF-M/25V		D040470084070S	
C706FL	00D 963 9005 875	C,ELECT 47UF-M/25V		D040470084070S	
C706FR	00D 963 9005 875	C,ELECT 47UF-M/25V		D040470084070S	
C707FL	00D 963 0234 205	C,ELECT 10UF-M/50V		D040100087070S	
C707FR	00D 963 0234 205	C,ELECT 10UF-M/50V		D040100087070S	
C707SW	00D 963 0234 205	C,ELECT 10UF-M/50V		D040100087070S	
C708FL	nsp	C,CERAMIC 33PF-J/50V		D010330167160S	
C708FR	nsp	C,CERAMIC 33PF-J/50V		D010330167160S	
C708SW	nsp	C,CERAMIC 47PF-J/50V		D010470167160S	
C709FL	nsp	C,CERAMIC 0.047UF-Z/50V		D011473597160S	
C709FR	nsp	C,CERAMIC 0.047UF-Z/50V		D011473597160S	
C709SW	nsp	C,CERAMIC 0.047UF-Z/50V		D011473597160S	
C710	00D 963 0223 009	R,CHIP THICK 0-J,1/16W		C20000006M160S	
C710FL	nsp	C,CERAMIC 100PF-J/50V		D010101167160S	
C710FR	nsp	C,CERAMIC 100PF-J/50V		D010101167160S	
C710SW	nsp	C,CERAMIC 100PF-J/50V		D010101167160S	
C711	00D 963 0223 009	R,CHIP THICK 0-J,1/16W		C20000006M160S	
C711FL	nsp	C,CERAMIC 0.047UF-Z/50V		D011473597160S	
C711FR	nsp	C,CERAMIC 0.047UF-Z/50V		D011473597160S	
C711SW	nsp	C,CERAMIC 0.047UF-Z/50V		D011473597160S	
C712	00D 963 0293 602	C,ELECT 1UF-M/50V (Pb Free)		D040010087150S	
C713-715	00D 963 0223 009	R,CHIP THICK 0-J,1/16W		C20000006M160S	
C716-727	00D 960 9009 814	C,CERAMIC 330PF-J/50V		D010331167160S	
C728-731	nsp	C,CERAMIC 20PF-J/50V		D010200167160S	
C732-739	00D 960 9009 814	C,CERAMIC 330PF-J/50V		D010331167160S	
C740-751	00D 963 0234 205	C,ELECT 10UF-M/50V		D040100087070S	
C751A	00D 963 0234 205	C,ELECT 10UF-M/50V		D040100087070S	
C751B	00D 963 0234 205	C,ELECT 10UF-M/50V		D040100087070S	
C751C	00D 963 0234 205	C,ELECT 10UF-M/50V		D040100087070S	
C751D	00D 963 0234 205	C,ELECT 10UF-M/50V		D040100087070S	

Ref. No.	Part No.	Part Name	Remarks		Q'ty	New
C751E	00D 963 0234 205	C,ELECT 10UF-M/50V		D040100087070S		
C751F	00D 963 0234 205	C,ELECT 10UF-M/50V		D040100087070S		
C751G	00D 963 0234 205	C,ELECT 10UF-M/50V		D040100087070S		
C751H	00D 963 0234 205	C,ELECT 10UF-M/50V		D040100087070S		
C751J	00D 963 0234 205	C,ELECT 10UF-M/50V		D040100087070S		
C751K	00D 963 0234 205	C,ELECT 10UF-M/50V		D040100087070S		
C751L	00D 963 0234 205	C,ELECT 10UF-M/50V		D040100087070S		
C751M	00D 963 0234 205	C,ELECT 10UF-M/50V		D040100087070S		
C751N	00D 963 0234 205	C,ELECT 10UF-M/50V		D040100087070S		
C751P	00D 963 0234 205	C,ELECT 10UF-M/50V		D040100087070S		
C751Q	00D 963 0234 205	C,ELECT 10UF-M/50V		D040100087070S		
C751R	00D 963 0234 205	C,ELECT 10UF-M/50V		D040100087070S		
C751S	00D 963 0234 205	C,ELECT 10UF-M/50V		D040100087070S		
C751T	00D 963 0234 205	C,ELECT 10UF-M/50V		D040100087070S		
C751U	00D 963 0234 205	C,ELECT 10UF-M/50V		D040100087070S		
C751V	00D 963 0234 205	C,ELECT 10UF-M/50V		D040100087070S		
C752	00D 963 0234 205	C,ELECT 10UF-M/50V		D040100087070S		
C752A	nsp	C,CERAMIC 0.047UF-Z/50V		D011473597160S		
C752B	nsp	C,CERAMIC 0.047UF-Z/50V		D011473597160S		
C752C	nsp	C,CERAMIC 0.047UF-Z/50V		D011473597160S		
C752D	nsp	C,CERAMIC 0.047UF-Z/50V		D011473597160S		
C752E	nsp	C,CERAMIC 0.047UF-Z/50V		D011473597160S		
C752F	nsp	C,CERAMIC 0.047UF-Z/50V		D011473597160S		
C752G	nsp	C,CERAMIC 0.047UF-Z/50V		D011473597160S		
C752H	nsp	C,CERAMIC 0.047UF-Z/50V		D011473597160S		
C752J	nsp	C,CERAMIC 0.047UF-Z/50V		D011473597160S		
C752K	nsp	C,CERAMIC 0.047UF-Z/50V		D011473597160S		
C752L	nsp	C,CERAMIC 0.047UF-Z/50V		D011473597160S		
C752M	nsp	C,CERAMIC 0.047UF-Z/50V		D011473597160S		
C752N	nsp	C,CERAMIC 0.047UF-Z/50V		D011473597160S		
C752P	nsp	C,CERAMIC 0.047UF-Z/50V		D011473597160S		
C752Q	nsp	C,CERAMIC 0.047UF-Z/50V		D011473597160S		
C752R	nsp	C,CERAMIC 0.047UF-Z/50V		D011473597160S		
C752S	nsp	C,CERAMIC 0.047UF-Z/50V		D011473597160S		
C752T	nsp	C,CERAMIC 0.047UF-Z/50V		D011473597160S		
C752U	nsp	C,CERAMIC 0.047UF-Z/50V		D011473597160S		
C752V	nsp	C,CERAMIC 0.047UF-Z/50V		D011473597160S		
C752W	nsp	C,CERAMIC 0.1UF-Z/50V		D011104597160S		
C752X	nsp	C,CERAMIC 0.1UF-Z/50V		D011104597160S		
C753-771	00D 963 0234 205	C,ELECT 10UF-M/50V		D040100087070S		
C772,773	00D 963 0293 806	C,ELECT 100UF-M/10V (Pb Free)		D040101082090S		
C774	nsp	C,FILM 0.15UF-K/63V		D020154078060S		
C775	00D 963 0021 900	C,FILM 0.047UF-J/100V		D02047306C060S		
C776	00D 960 9008 640	C,FILM 0.022UF-J/100V		D02022306C060S		
C777	00D 963 0234 205	C,ELECT 10UF-M/50V		D040100087070S		
C778,779	nsp	C,CERAMIC 100PF-J/50V		D010101167160S		
C780	00D 963 0234 205	C,ELECT 10UF-M/50V		D040100087070S		
C781	00D 960 9008 640	C,FILM 0.022UF-J/100V		D02022306C060S		
C782	00D 963 0021 900	C,FILM 0.047UF-J/100V		D02047306C060S		
C783	nsp	C,FILM 0.15UF-K/63V		D020154078060S		
C784-790	00D 963 0293 806	C,ELECT 100UF-M/10V (Pb Free)		D040101082090S		
C791,792	00D 963 0234 205	C,ELECT 10UF-M/50V		D040100087070S		
C794	00D 963 0293 806	C,ELECT 100UF-M/10V (Pb Free)		D040101082090S		
C796-799	00D 963 0234 205	C,ELECT 10UF-M/50V		D040100087070S		
C800,801	00D 960 9010 832	C,ELECT 10UF-M/16V		D040100083050S		

Ref. No.	Part No.	Part Name	Remarks		Q'ty	New
OTHERS PARTS GROUP						
CLAMP501	nsp	CLAMP WIRE(SOLDER)		4330000120000S		
CN306	nsp	CN,WIRE 480MM/3P		L000481030060S		
CN514	nsp	CN,WIRE 13P		L000181130010S		
CN702	nsp	CN.HOUSING 15P		L120912150010S		
CN703	nsp	CN.WAFER 8P		L101100030810S		
CN704	nsp	CN.WAFER 19P		L101100031910S		
CN706	nsp	CN,WIRE 5P		L000121050080S		
CP704	nsp	CN.WAFER 15P		L101220150000S		
CP705	nsp	CN.WAFER 3P		L101220030000S		
JACK701	00D 963 0132 103	TER,RCA 4PIN		G602405B0400YS		
JACK702	00D 963 0388 203	TER,RCA 4PIN		G602405B5500YS		
JACK703	00D 963 0132 103	TER,RCA 4PIN		G602405B0400YS		
JACK704,705	00D 963 0132 307	TER,RCA 6PIN		G603603B05000S		

POWER P.W.B. UNIT ASS'Y

	Ref. No.	Part No.	Part Name	Remarks		Q'ty	New
SEMICONDUCTORS GROUP							
△	IC501	00D 963 0057 806	IC KIA78R05PI		J126780500370S		
	IC502	00D 960 0195 808	IC ICP-N15		J120001500030S		
	IC515	00D 960 0174 900	IC KIA7815API		J126781500000S		
	IC516	00D 963 0021 502	IC KIA7915PI		J126791500030S		
	IC517	00D 960 0100 301	IC KIA7812API		J126781200040S		
	Q501	00D 960 0196 409	TR 2SC1740SR		J5021740S0010S		
	Q502	00D 963 0121 208	TR KRC107M		J6020107M0010S		
	Q503	00D 960 0196 409	TR 2SC1740SR		J5021740S0010S		
	D501-503	00D 276 0401 905	D,SWITCHING 1SS133T		K000013300520S		
	D504-507	00D 963 0328 409	D,SWITCHING 1N4007		K000400700010S		
	D508,509	00D 276 0401 905	D,SWITCHING 1SS133T		K000013300520S		
	D521,522	00D 276 0401 905	D,SWITCHING 1SS133T		K000013300520S		
	D523-526	00D 963 0328 409	D,SWITCHING 1N4007		K000400700010S		
	ZD501	00D 960 0095 500	D,ZENER MTZJ5.1B		K06005R144520S		
	ZD502	00D 963 0219 903	D,ZENER MTZJ16B		K06016R044520S		
RESISTORS GROUP							
	R507	00D 963 0232 809	R,METAL FILM 10-J,1/4W		C060010063520S		
	R516-519	00D 963 0216 003	R,METAL FILM 0.22-J,1W		C060R22065050S		
	R520	00D 963 0215 907	R,METAL FILM 4.7-J,1W		C0604R7065050S		
CAPACITORS GROUP							
	C501	00D 963 0234 205	C,ELECT 10UF-M/50V		D040100087070S		
	C502	00D 963 0217 002	C,ELECT 3300UF-M/16V		D040332083010S		
	C503	00D 963 0293 602	C,ELECT 1UF-M/50V (Pb Free)		D040010087150S		
	C504	00D 963 0323 802	C,CERAMIC AC(SAFETY) 0.0047UF 250VAC		D00847208H010S		
	C506	00D 963 0293 602	C,ELECT 1UF-M/50V (Pb Free)		D040010087150S		
	C526,527	00D 960 0186 202	C,ELECT 220UF-M/35V		D040221085050S		
	C528	00D 963 0324 908	C,ELECT 4700UF-M/35V		D040472085020S		
	C529	00D 963 0224 707	C,ELECT 2200UF-M/35V		D040222085020S		
	C530-532	00D 963 0021 900	C,FILM 0.047UF-J/100V		D02047306C060S		
	C534,535	00D 963 0234 205	C,ELECT 10UF-M/50V		D040100087070S		
OTHERS PARTS GROUP							
	BKT501	nsp	SHIELD PLATE GND		3070045526010S		
	CLAMP102,103	nsp	CLAMP WIRE(SOLDER)		4330000120000S		
	CN505	nsp	CN.WAFER 7P		L101100030710S		
	CN506	nsp	CN.WAFER 12P		L101100031210S		
	CP501	nsp	CN.WAFER 2CKT,YEL		L108353280290S		
	CP503	nsp	CN.WAFER 2CKT,RED		L108353280280S		
	CP504	nsp	CN.WAFER ST2P		L108202000220S		
	CP505	nsp	CN.WAFER 7P		L101100040710S		
	CP506	nsp	CN.WAFER 12P		L101100041210S		
	CP511	nsp	CN.WAFER 9P		L101220090000S		
	CP513	nsp	CN.WAFER 3P ANGLE		L102526803010S		

	Ref. No.	Part No.	Part Name	Remarks		Q'ty	New
	CP514	nsp	CN.WAFER 13P		L101220130000S		
⚠	F501	00D 960 0194 906	FUSE 125V-S8A		G650802121070S		
	F501A	nsp	HOLDER,FUSE CLIP		G645000050010S		
	F501B	nsp	HOLDER,FUSE CLIP		G645000050010S		
⚠	F503	00D 960 0194 906	FUSE 125V-S8A		G650802121070S		
	F503A	nsp	HOLDER,FUSE CLIP		G645000050010S		
	F503B	nsp	HOLDER,FUSE CLIP		G645000050010S		
	GND501	nsp	TERMINAL EARTH		3790040886000S		
	RLY501	00D 963 0218 205	RELAY HL3-1A-9SH DC9V 1A		G680090102020S		
⚠	SUB501	00D 963 0382 908	SUB TRANS		8200280150430S		
		nsp	HEAT SINK		2120043538050S		
		nsp	HEAT SINK		2120044298010S		
		nsp	SCREW,TAP TITE +2S 3*8 B-TYPE ZNW/BH		B020030081B10S		
		00D 963 0328 409	D,SWITCHING 1N4007		K000400700010S		
		nsp	LABEL AVC-1508 T8A / FUSE		5507000001080S		
⚠		00D 203 3976 002	SOCKET,POWER RECEPTA		G435204004010S		

2CH-AMP P.W.B. UNIT ASS'Y

Ref. No.	Part No.	Part Name	Remarks	Q'ty	New
SEMICONDUCTORS GROUP					
IC401D	00D 960 0159 501	IC KIA7805API		J126780500110S	
IC401H	00D 963 0388 805	CN,WIRE 110MM/3P		L000111030040S	
IC402D	00D 963 0226 608	IC KIA78R33PI		J12678R330010S	
IC402X	00D 963 0366 603	IC KIA1117PI50		J126111750050S	
IC403D	00D 963 0366 706	IC KIA1117PI00		J126111700050S	
Q401SBL	00D 963 0044 204	TR 2SD2390-Y		J5032390Y0000S	
Q401SBR	00D 963 0044 204	TR 2SD2390-Y		J5032390Y0000S	
Q402D	00D 960 0097 304	TR KRC102M		J6020102M0010S	
Q402SBL	00D 963 0044 107	TR 2SB1560-Y		J5011560Y0000S	
Q402SBR	00D 963 0044 107	TR 2SB1560-Y		J5011560Y0000S	
Q403SBL	00D 963 0280 107	TR 2SC3964		J502396400000S	
Q403SBR	00D 963 0280 107	TR 2SC3964		J502396400000S	
Q404SBL	00D 960 0196 506	TR KSC1845F		J5021845F0000S	
Q404SBR	00D 960 0196 506	TR KSC1845F		J5021845F0000S	
Q405SBL	00D 273 0459 903	TR KTC2874B		J502287400010S	
Q405SBR	00D 273 0459 903	TR KTC2874B		J502287400010S	
Q406SBL	00D 960 0196 205	TR KSA992F		J5000992F0050S	
Q406SBR	00D 960 0196 205	TR KSA992F		J5000992F0050S	
Q407SBL	00D 960 0196 205	TR KSA992F		J5000992F0050S	
Q407SBR	00D 960 0196 205	TR KSA992F		J5000992F0050S	
Q408SBL	00D 960 0196 506	TR KSC1845F		J5021845F0000S	
Q408SBR	00D 960 0196 506	TR KSC1845F		J5021845F0000S	
Q409D	00D 960 0097 304	TR KRC102M		J6020102M0010S	
D401H	00D 963 0328 409	D,SWITCHING 1N4007		K000400700010S	
D401SBL	00D 963 0341 004	D,SWITCHING KDS4148U		K005041480030S	
D401SBR	00D 963 0341 004	D,SWITCHING KDS4148U		K005041480030S	
D401X	00D 963 0328 409	D,SWITCHING 1N4007		K000400700010S	
D402	00D 276 0401 905	D,SWITCHING 1SS133T		K000013300520S	
D402H	00D 963 0328 409	D,SWITCHING 1N4007		K000400700010S	
D402SBL	00D 963 0341 004	D,SWITCHING KDS4148U		K005041480030S	
D402SBR	00D 963 0341 004	D,SWITCHING KDS4148U		K005041480030S	
D402X	00D 963 0328 409	D,SWITCHING 1N4007		K000400700010S	
D403	00D 276 0401 905	D,SWITCHING 1SS133T		K000013300520S	
ZD401D	00D 960 0095 607	D,ZENER MTZJ5.6B		K06005R644520S	
ZD401SBL	00D 963 0367 008	D,ZENER 0.2W 3.3V UDZ S		K06603R34P400S	
ZD401SBR	00D 963 0367 008	D,ZENER 0.2W 3.3V UDZ S		K06603R34P400S	
ZD402SBL	00D 963 0367 008	D,ZENER 0.2W 3.0V UDZ S		K06603R04P400S	
ZD402SBR	00D 963 0367 008	D,ZENER 0.2W 3.0V UDZ S		K06603R04P400S	
RESISTORS GROUP					
R401D	00D 963 9006 269	R,FIXED 1WJ-0.22		N113135622820S	
R401H	00D 963 9006 269	R,FIXED 1WJ-0.22		N113135622820S	
R401X	00D 963 9006 269	R,FIXED 1WJ-0.22		N113135622820S	
R402D	00D 963 9006 269	R,FIXED 1WJ-0.22		N113135622820S	
R402H	00D 963 9006 269	R,FIXED 1WJ-0.22		N113135622820S	
R402X	00D 963 9006 269	R,FIXED 1WJ-0.22		N113135622820S	
R410SBL	00D 963 9005 642	R,METAL FILM 1.2K-J,1W		C060012265050S	
R410SBR	00D 963 9005 642	R,METAL FILM 1.2K-J,1W		C060012265050S	
R411SBL	00D 960 9010 719	R,METAL FILM 47-J,1W		C060047065060S	
R411SBR	00D 960 9010 719	R,METAL FILM 47-J,1W		C060047065060S	

Ref. No.	Part No.	Part Name	Remarks		Q'ty	New
R414SBL	00D 963 9006 285	R,FIXED 1WJ-5.6K		N113135656220S		
R414SBR	00D 963 9006 285	R,FIXED 1WJ-5.6K		N113135656220S		
R415SBL	00D 963 9006 285	R,FIXED 1WJ-5.6K		N113135656220S		
R415SBR	00D 963 9006 285	R,FIXED 1WJ-5.6K		N113135656220S		
R419SBL	00D 963 0215 907	R,METAL FILM 4.7-J,1W		C0604R7065050S		
R419SBR	00D 963 0215 907	R,METAL FILM 4.7-J,1W		C0604R7065050S		
R420SBL	00D 963 0215 907	R,METAL FILM 4.7-J,1W		C0604R7065050S		
R420SBR	00D 963 0215 907	R,METAL FILM 4.7-J,1W		C0604R7065050S		
R421SBL	00D 963 0345 903	R,FIXED 2WJ-0.47		N113136647820S		
R421SBR	00D 963 0345 903	R,FIXED 2WJ-0.47		N113136647820S		
R422SBL	00D 963 0345 903	R,FIXED 2WJ-0.47		N113136647820S		
R422SBR	00D 963 0345 903	R,FIXED 2WJ-0.47		N113136647820S		
R423SBL	00D 963 0345 903	R,FIXED 2WJ-0.47		N113136647820S		
R423SBR	00D 963 0345 903	R,FIXED 2WJ-0.47		N113136647820S		
R424SBL	00D 963 0345 903	R,FIXED 2WJ-0.47		N113136647820S		
R424SBR	00D 963 0345 903	R,FIXED 2WJ-0.47		N113136647820S		
R429SBL	00D 963 9006 256	R,FIXED 1WJ-10		N113135610020S		
R429SBR	00D 963 9006 256	R,FIXED 1WJ-10		N113135610020S		
R430SBL	00D 963 9006 256	R,FIXED 1WJ-10		N113135610020S		
R430SBR	00D 963 9006 256	R,FIXED 1WJ-10		N113135610020S		
VR401,402	00D 963 0366 407	VR,SEMI CARBON EVN-DCAA03B 1KB		C541102315000S		
CAPACITORS GROUP						
C401D	00D 963 0021 900	C,FILM 0.047UF-J/100V		D02047306C060S		
C401H	00D 963 0021 900	C,FILM 0.047UF-J/100V		D02047306C060S		
C401SBL	00D 963 9006 544	C,ELECT 22UF-M/25V		D040220084050S		
C401SBR	00D 963 9006 544	C,ELECT 22UF-M/25V		D040220084050S		
C401X	nsp	C,CERAMIC 0.1UF-K/50V		D011104577160S		
C402D	00D 963 0021 900	C,FILM 0.047UF-J/100V		D02047306C060S		
C402H	00D 963 0021 900	C,FILM 0.047UF-J/100V		D02047306C060S		
C402SBL	00D 963 0234 205	C,ELECT 10UF-M/50V		D040100087070S		
C402SBR	00D 963 0234 205	C,ELECT 10UF-M/50V		D040100087070S		
C402X	00D 963 9003 097	C,FILM 0.1UF-K/250V		D02010407H080S		
C403D	00D 963 0021 900	C,FILM 0.047UF-J/100V		D02047306C060S		
C403H	00D 963 0021 900	C,FILM 0.047UF-J/100V		D02047306C060S		
C403SBL	00D 963 0367 101	C,CERAMIC 220PF-J/500V		D00422106D05CS		
C403SBR	00D 963 0367 101	C,CERAMIC 220PF-J/500V		D00422106D05CS		
C404D	00D 960 0133 404	C,ELECT 1000UF 16V		D040103083020S		
C404H	00D 963 0217 002	C,ELECT 330UF-M/16V		D040332083010S		
C404SBL	00D 963 0338 208	C,CERAMIC 470PF-K/500V		D00447127D050S		
C404SBR	00D 963 0338 208	C,CERAMIC 470PF-K/500V		D00447127D050S		
C404X	00D 963 0276 409	C,ELECT 100UF-M/16V		D040101083090S		
C405D	00D 963 0338 402	C,ELECT 330UF-M/6.3V		D040331081050S		
C405SBL	00D 963 0216 100	C,CERAMIC 33PF-J/500V		D00033006D050S		
C405SBR	00D 963 0216 100	C,CERAMIC 33PF-J/500V		D00033006D050S		
C406D	nsp	C,CERAMIC 0.1UF-K/50V		D011104577160S		
C406SBL	00D 963 0293 709	C,ELECT 100UF-M/10V		D040101082070S		
C406SBR	00D 963 0293 709	C,ELECT 100UF-M/10V		D040101082070S		
C406X	nsp	C,CERAMIC 1000PF-K/50V		D011102777160S		
C407D	nsp	C,CERAMIC 1000PF-K/50V		D011102777160S		
C407SBL	00D 963 9003 194	C,FILM 0.0022UF-J/100V		D02022206C060S		
C407SBR	00D 963 9003 194	C,FILM 0.0022UF-J/100V		D02022206C060S		
C407X	00D 963 0293 709	C,ELECT 100UF-M/10V		D040101082070S		
C408D	00D 963 0338 402	C,ELECT 330UF-M/6.3V		D040331081050S		

Ref. No.	Part No.	Part Name	Remarks		Q'ty	New
C408SBL	00D 963 0234 506	C,ELECT 47UF-M/50V (Pb Free)		D040470087070S		
C408SBR	00D 963 0234 506	C,ELECT 47UF-M/50V (Pb Free)		D040470087070S		
C409D	nsp	C,CERAMIC 0.1UF-K/50V		D011104577160S		
C409SBL	00D 963 9003 084	C,CERAMIC 100PF-K/500V		D00410106D050S		
C409SBR	00D 963 9003 084	C,CERAMIC 100PF-K/500V		D00410106D050S		
C410D	00D 963 0338 402	C,ELECT 330UF-M/6.3V		D040331081050S		
C410SBL	00D 963 0234 205	C,ELECT 10UF-M/50V		D040100087070S		
C410SBR	00D 963 0234 205	C,ELECT 10UF-M/50V		D040100087070S		
C411D	nsp	C,CERAMIC 0.1UF-K/50V		D011104577160S		
C411SBL	00D 963 9003 084	C,CERAMIC 100PF-K/500V		D00410106D050S		
C411SBR	00D 963 9003 084	C,CERAMIC 100PF-K/500V		D00410106D050S		
C412D	nsp	C,CERAMIC 0.1UF-K/50V		D011104577160S		
C412SBL	nsp	C,CERAMIC 0.022UF-K/25V		D011223777160S		
C412SBR	nsp	C,CERAMIC 0.022UF-K/25V		D011223777160S		
C413D	00D 963 0024 907	C,ELECT 1000UF-M/6.3V		D040102081060S		
C413SBL	00D 963 9003 097	C,FILM 0.1UF-K/250V		D02010407H080S		
C413SBR	00D 963 9003 097	C,FILM 0.1UF-K/250V		D02010407H080S		
C443	nsp	C,CERAMIC 1000PF-K/50V		D011102777160S		
OTHERS PARTS GROUP						
CLAMP401	nsp	CLAMP WIRE(SOLDER)		4330000120000S		
CN203	nsp	CN,WIRE 160MM/3P		L000161030060S		
CN401A	nsp	CN,WIRE 5P		L000191050030S		
CN405	nsp	CN,WIRE 320MM/5P		L000321050020S		
CN705	nsp	CN,WIRE 150MM/3P		L000151030010S		
CN904	nsp	CN,WIRE 6P		L000141060030S		
CP102	nsp	CN.WAFER 2.5MM 5267-03A 3P		L102526700300S		
CP201	nsp	CN.WAFER 10P		L101220100000S		
CP402	nsp	CN.WAFER 3P		L102526700300S		
L401SBL	nsp	COIL INDUCTOR 0.5UH		D330R50000000S		
L401SBR	nsp	COIL INDUCTOR 0.5UH		D330R50000000S		
TP401,402	nsp	CN.WAFER 3P ANGLE		L101530150310S		
	00D 963 0328 409	D,SWITCHING 1N4007		K000400700010S		

CPU P.W.B. UNIT ASS'Y

Ref. No.	Part No.	Part Name	Remarks	Q'ty	New
SEMICONDUCTORS GROUP					
IC712-715	00D 963 0024 004	IC NJM2068M		J121206800020S	
IC804	963243000020D	IC,CPU MICRO PROCESS	M30626FHPFP	8952150800015	
IC807	00D 963 0326 906	ICNJM2068M		J121206800020S	
IC813	00D 963 0367 204	IC SN74HC151PWR		J040741510070S	
IC817	00D 963 0244 907	IC SN74LV14APWR		J040741400180S	
IC818	00D 963 0367 307	IC SN74AHCU04PWR		J040740400290S	
IC824	00D 963 0043 807	IC BA4510F-E2/SOP8		J121451000010S	
IC827	00D 963 0043 807	IC BA4510F-E2/SOP8		J121451000010S	
IC830	00D 262 2813 903	SN74AHCT08PW-EL2 +C		J040740800190S	
Q704C	00D 963 0044 301	TR KTC2875B(MB)	<div style="border: 1px solid black; border-radius: 15px; padding: 5px; width: fit-content;"> ファームウェアをアップデートするときは、SDIで最終バージョンを確認して下さい。サービス基板はアップデートして使用下さい。 When update Firmware, please confirm a last version in SDI. Use the service board after updating it. </div>	J5222875B0010S	
Q704FL	00D 963 0044 301	TR KTC2875B(MB)		J5222875B0010S	
Q704FR	00D 963 0044 301	TR KTC2875B(MB)		J5222875B0010S	
Q704SBL	00D 963 0044 301	TR KTC2875B(MB)		J5222875B0010S	
Q704SBR	00D 963 0044 301	TR KTC2875B(MB)		J5222875B0010S	
Q704SL	00D 963 0044 301	TR KTC2875B(MB)		J5222875B0010S	
Q704SR	00D 963 0044 301	TR KTC2875B(MB)		J5222875B0010S	
Q704SW	00D 963 0044 301	TR KTC2875B(MB)		J5222875B0010S	
Q806	00D 963 0121 509	TR KTC3875S		J522038750210S	
Q807	00D 960 0285 006	TR KRC104S		J522104S00210S	
Q810D	00D 963 0245 100	D,SWITCHING KDS226ST1(C3)		K005022600020S	
Q811D	00D 963 0245 100	D,SWITCHING KDS226ST1(C3)		K005022600020S	
Q812D	00D 963 0120 801	TR KRC102S		J522010200210S	
Q813D	00D 963 0120 704	TR KRA102S		J520010200210S	
D801-804	00D 963 0355 401	D,SWITCHING KDS4148U		K005041480030S	
D805	00D 963 0328 409	D,SWITCHING 1N4007		K000400700010S	
D807	00D 963 0355 401	D,SWITCHING KDS4148U		K005041480030S	
D807D	00D 963 0355 401	D,SWITCHING KDS4148U		K005041480030S	
D808D	00D 963 0341 305	D,ESD IMSA-6802-01A		K067680200010S	
D809D	00D 963 0355 401	D,SWITCHING KDS4148U		K005041480030S	
D810D	00D 963 0341 305	D,ESD IMSA-6802-01A		K067680200010S	
D811D	00D 963 0341 305	D,ESD IMSA-6802-01A		K067680200010S	
ZD801	00D 963 0047 502	D,ZENER MTZJ3.3B		K06003R344520S	
RESISTORS GROUP					
R857	00D 960 9003 807	R,METAL FILM 100-J,1/4W		C060010163050S	
CAPACITORS GROUP					
C751C	00D 963 0234 205	C,ELECT 10UF-M/50V		D040100087070S	
C751FL	00D 963 0234 205	C,ELECT 10UF-M/50V		D040100087070S	
C751FR	00D 963 0234 205	C,ELECT 10UF-M/50V		D040100087070S	
C751SBL	00D 963 0234 205	C,ELECT 10UF-M/50V		D040100087070S	
C751SBR	00D 963 0234 205	C,ELECT 10UF-M/50V		D040100087070S	
C751SL	00D 963 0234 205	C,ELECT 10UF-M/50V		D040100087070S	
C751SR	00D 963 0234 205	C,ELECT 10UF-M/50V		D040100087070S	
C751SW	00D 963 0234 205	C,ELECT 10UF-M/50V		D040100087070S	
C752C	00D 963 0350 503	C,CERAMIC 390PF-J/50V		D010391167160S	
C752FL	00D 963 0223 708	C,CERAMIC 270PF-J/50V		D010271167160S	
C752FR	00D 963 0223 708	C,CERAMIC 270PF-J/50V		D010271167160S	
C752SBL	00D 960 9009 814	C,CERAMIC 330PF-J/50V		D010331167160S	

Ref. No.	Part No.	Part Name	Remarks	Q'ty	New
C752SBR	00D 960 9009 814	C,CERAMIC 330PF-J/50V		D010331167160S	
C752SL	00D 960 9009 814	C,CERAMIC 330PF-J/50V		D010331167160S	
C752SR	00D 960 9009 814	C,CERAMIC 330PF-J/50V		D010331167160S	
C752SW	00D 963 0350 503	C,CERAMIC 390PF-J/50V		D010391167160S	
C753C	00D 963 0224 008	C,CERAMIC 470PF-J/50V		D010471167160S	
C753FL	00D 963 0223 902	C,CERAMIC 39PF-J/50V		D010390167160S	
C753FR	00D 963 0223 902	C,CERAMIC 39PF-J/50V		D010390167160S	
C753SBL	00D 963 0223 708	C,CERAMIC 270PF-J/50V		D010271167160S	
C753SBR	00D 963 0223 708	C,CERAMIC 270PF-J/50V		D010271167160S	
C753SL	00D 963 0223 708	C,CERAMIC 270PF-J/50V		D010271167160S	
C753SR	00D 963 0223 708	C,CERAMIC 270PF-J/50V		D010271167160S	
C753SW	00D 963 0224 008	C,CERAMIC 470PF-J/50V		D010471167160S	
C755C	nsp	C,CERAMIC 0.1UF-Z/50V		D011104597160S	
C755FL	nsp	C,CERAMIC 0.1UF-Z/50V		D011104597160S	
C755FR	nsp	C,CERAMIC 0.1UF-Z/50V		D011104597160S	
C755SBL	nsp	C,CERAMIC 0.1UF-Z/50V		D011104597160S	
C755SBR	nsp	C,CERAMIC 0.1UF-Z/50V		D011104597160S	
C755SL	nsp	C,CERAMIC 0.1UF-Z/50V		D011104597160S	
C755SR	nsp	C,CERAMIC 0.1UF-Z/50V		D011104597160S	
C755SW	nsp	C,CERAMIC 0.1UF-Z/50V		D011104597160S	
C756C	00D 963 9003 194	C,FILM 0.0022UF-J/100V		D02022206C060S	
C756FL	00D 963 9003 194	C,FILM 0.0022UF-J/100V		D02022206C060S	
C756FR	00D 963 9003 194	C,FILM 0.0022UF-J/100V		D02022206C060S	
C756SBL	00D 963 9003 194	C,FILM 0.0022UF-J/100V		D02022206C060S	
C756SBR	00D 963 9003 194	C,FILM 0.0022UF-J/100V		D02022206C060S	
C756SL	00D 963 9003 194	C,FILM 0.0022UF-J/100V		D02022206C060S	
C756SR	00D 963 9003 194	C,FILM 0.0022UF-J/100V		D02022206C060S	
C756SW	00D 963 9003 194	C,FILM 0.0022UF-J/100V		D02022206C060S	
C757C	nsp	C,CERAMIC 10UF-Z/10V		D011106592200S	
C757FL	nsp	C,CERAMIC 10UF-Z/10V		D011106592200S	
C757FR	nsp	C,CERAMIC 10UF-Z/10V		D011106592200S	
C757SBL	nsp	C,CERAMIC 10UF-Z/10V		D011106592200S	
C757SBR	nsp	C,CERAMIC 10UF-Z/10V		D011106592200S	
C757SL	nsp	C,CERAMIC 10UF-Z/10V		D011106592200S	
C757SR	nsp	C,CERAMIC 10UF-Z/10V		D011106592200S	
C757SW	nsp	C,CERAMIC 10UF-Z/10V		D011106592200S	
C803	nsp	C,CERAMIC 100PF-J/50V		D010101167160S	
C804,805	nsp	C,CERAMIC 0.1UF-Z/50V		D011104597160S	
C806	nsp	C,CERAMIC 0.01UF-K/50V		D011103777160S	
C807,808	nsp	C,CERAMIC 0.022UF-Z/50V		D011223597160S	
C809	00D 963 0293 709	C,ELECT 100UF-M/10V		D040101082070S	
C810	nsp	C,CERAMIC 0.1UF-Z/50V		D011104597160S	
C813	nsp	C,CERAMIC 0.1UF-Z/50V		D011104597160S	
C818	00D 960 9010 010	C,ELECT 4.7UF-M/50V		D0404R7087250S	
C819	nsp	C,CERAMIC 0.01UF-K/50V		D011103777160S	
C826,827	nsp	R,CHIP THICK 10K-J,1/16W		C20001036M160S	
C829	nsp	R,CHIP THICK 10K-J,1/16W		C20001036M160S	
C834,835	00D 963 0234 205	C,ELECT 10UF-M/50V		D040100087070S	
C836,837	nsp	C,CERAMIC 0.022UF-Z/50V		D011223597160S	
C838,839	nsp	C,CERAMIC 0.047UF-Z/50V		D011473597160S	
C865L	nsp	C,CERAMIC 120PF-J/50V		D010121167160S	
C865R	nsp	C,CERAMIC 120PF-J/50V		D010121167160S	
C871L	00D 963 0216 304	C,FILM 0.001UF-J/100V		D02010206C060S	
C871R	00D 963 0216 304	C,FILM 0.001UF-J/100V		D02010206C060S	
C916D	nsp	C,CERAMIC 0.1UF-Z/50V		D011104597160S	
C917D	nsp	C,CERAMIC 0.1UF-Z/50V		D011104597160S	

Ref. No.	Part No.	Part Name	Remarks		Q'ty	New
C918D	nsp	C,CERAMIC 0.1UF-Z/50V		D011104597160S		
C920D	nsp	C,CERAMIC 0.1UF-Z/50V		D011104597160S		
C921D	nsp	C,CERAMIC 100PF-J/50V		D010101167160S		
C923D	nsp	C,CERAMIC 22PF-J/50V		D010220167160S		
C924D	nsp	C,CERAMIC 22PF-J/50V		D010220167160S		
C926D	nsp	C,CERAMIC 22PF-J/50V		D010220167160S		
C927D	00D 963 9005 862	C,ELECT 47UF-M/16V		D040470083080S		
C928D	00D 963 9005 862	C,ELECT 47UF-M/16V		D040470083080S		
C930D	00D 963 9005 862	C,ELECT 47UF-M/16V		D040470083080S		
C931D	nsp	C,CERAMIC 100PF-J/50V		D010101167160S		
C932D	nsp	C,CERAMIC 0.01UF-K/50V		D011103777160S		
C933D	nsp	C,CERAMIC 0.01UF-K/50V		D011103777160S		
C934D	nsp	C,CERAMIC 0.01UF-K/50V		D011103777160S		
C935D	00D 960 9010 010	C,ELECT 4.7UF-M/50V		D0404R7087250S		
C936D	00D 960 9010 010	C,ELECT 4.7UF-M/50V		D0404R7087250S		
C937D	nsp	C,CERAMIC 1000PF-K/50V		D011102777160S		
C938D	00D 960 9010 010	C,ELECT 4.7UF-M/50V		D0404R7087250S		
C939D	nsp	C,CERAMIC 0.01UF-K/50V		D011103777160S		
C940D	nsp	C,CERAMIC 0.01UF-K/50V		D011103777160S		
C941D	00D 963 0244 606	C,ELECT 0.1UF-M/50V (Pb Free)		D040R10087080S		
C950D	nsp	C,CERAMIC 0.1UF-Z/50V		D011104597160S		
C951D	nsp	C,CERAMIC 0.1UF-Z/50V		D011104597160S		
C952D	00D 963 0234 205	C,ELECT 10UF-M/50V		D040100087070S		
C953D	00D 963 0234 205	C,ELECT 10UF-M/50V		D040100087070S		
C954D	nsp	C,CERAMIC 0.1UF-Z/50V		D011104597160S		
C955D	nsp	C,CERAMIC 0.1UF-Z/50V		D011104597160S		
C956D	nsp	C,CERAMIC 22PF-J/50V		D010220167160S		
C957D	nsp	C,CERAMIC 0.1UF-Z/50V		D011104597160S		
C959D	nsp	C,CERAMIC 22PF-J/50V		D010220167160S		
BC801	00D 254 4666 005	CE04W0H105ZC(FG)		D041105090010S		
OTHERS PARTS GROUP						
BD802,803	nsp	COIL,BEAD MB-160808		D340160800060S		
BD805-809	nsp	COIL,BEAD MB-160808		D340160800060S		
BD809D	nsp	COIL,BEAD MB-160808		D340160800060S		
CN105,106	nsp	CN.WAFER 5P		L101100030510S		
CN108	00D 963 0085 302	CN.WAFER 17P		L101100031710S		
CP01	nsp	CN.WAFER 16P		L101100040910S		
CP301A	00D 963 0367 400	CN.FPC 35P		L131524923520S		
CP701	nsp	CN.WAFER 19P		L101100041910S		
CP702	nsp	CN.WAFER 15P		L100912150010S		
CP703	nsp	CN.WAFER 8P		L101100040810S		
CP802	nsp	CN.WAFER 16P		L100912160010S		
CP803	nsp	CN.WAFER 16P		L101100041610S		
CP804	nsp	CN.WAFER 15P		L100912150010S		
CP805	nsp	CN.WAFER 08P		L100912080010S		
CP1001	nsp	CN.WAFER 08P		L101100040810S		
CP1002	nsp	CN.WAFER 9P		L101100040910S		
JACK801	00D 963 0217 905	TER,RCA 2PIN		G601206A0200YS		
JACK802	00D 963 0294 601	JACK,D3.5 EARPHONE		G40100350000YS		

Ref. No.	Part No.	Part Name	Remarks		Q'ty	New
L801D	nsp	COIL INDUCTOR 4.7UH		D3304R7000150S		
L802D	nsp	COIL INDUCTOR 4.7UH		D3304R7000150S		
L803D	nsp	COIL INDUCTOR 4.7UH		D3304R7000150S		
L804D	nsp	COIL INDUCTOR 4.7UH		D3304R7000150S		
L805D	nsp	COIL INDUCTOR 4.7UH		D3304R7000150S		
L806D	nsp	COIL INDUCTOR 22UH		D330220010520S		
L807D	nsp	COIL INDUCTOR 22UH		D330220010520S		
TP803	nsp	CN.WAFER 8P		L101220080000S		
TP804	nsp	CN.WAFER 4P		L101220040000S		
X801	00D 963 0217 701	RESONATOR,CERAMIC ZTT12.00MT		E830120000060S		
OPT801D	00D 963 0237 503	MODULE JSR1165-C		E100116500040S		
OPT802D	00D 963 0237 503	MODULE JSR1165-C		E100116500040S		
OPT804D	00D 963 0225 104	MODULE JST1165-B		E100116500030S		
	nsp	CN,WIRE 160MM/1P		L000161010040S		

HDMI P.W.B. UNIT ASS'Y

Ref. No.	Part No.	Part Name	Remarks	Q'ty	New
SEMICONDUCTORS GROUP					
IC01	nsp	SII9185CTU		00D2623721007	
IC03	nsp	IC SE1117-1.8		J126111718010S	
IC12	nsp	IC BU4094BCF-E2		J040140940030S	
IC801	nsp	ADSP21367KSZ1A1136		00D2623709016	
IC802	nsp	W9864G2GH-7		00D2623746008	
IC803	nsp	IC EN29LV160T-70TCP		J005291600010S	
IC807	nsp	LC89057W-VF4A		00D2623449004	
IC808	nsp	ADAU1328BSTZ1136		00D2623645015	
IC809-811	nsp	IC SN74LVC244APWR		J040742440230S	
IC812	nsp	IC SN74HCT244PWR		J040742440220S	
IC814,815	nsp	IC SN74HCT00PWR		J040740000210S	
IC816	nsp	74LVX157MTC +C		00D2622870904	
IC823	nsp	IC KIA7805API		J126780500110S	
IC825,826	nsp	IC SN74LVC74APWR		J040747400200S	
IC832	nsp	IC SE1117-33-PF		J126111733020S	
Q01,02	nsp	TR KRC102S		J522010200210S	
Q03,04	nsp	TR KRC104S		J522104S00210S	
Q07	nsp	TR KRC104S		J522104S00210S	
Q18,19	nsp	TR KRC104S		J522104S00210S	
Q810D	nsp	TR KRC102S		J522010200210S	
Q811D	nsp	TR KRA102S		J520010200210S	
Q814D	nsp	TR KRA102S		J520010200210S	
D01-36	nsp	D,ESD IMSA-6802-01A		K067680200010S	
D44	nsp	D,SWITCHING KDS4148U		K005041480030S	
ZD101	nsp	D,ZENER 0.2W 5.1V UDZ		K06605R14P400S	
CAPACITORS GROUP					
C01	nsp	C,CERAMIC 1000PF-K/50V		D011102777160S	
C02-05	nsp	C,CERAMIC 0.1UF-K/50V		D011104577162S	
C06,07	nsp	C,CERAMIC 1000PF-K/50V		D011102777160S	
C08-14	nsp	C,CERAMIC 0.1UF-K/50V		D011104577162S	
C15-17	nsp	C,CERAMIC 1000PF-K/50V		D011102777160S	
C18,19	nsp	C,CERAMIC 0.1UF-K/50V		D011104577162S	
C20	nsp	C,CERAMIC 1000PF-K/50V		D011102777160S	
C21	nsp	C,CERAMIC 100PF-J/50V		D010101167160S	
C22	nsp	C,CERAMIC 1000PF-K/50V		D011102777160S	
C23	nsp	C,CERAMIC 100PF-J/50V		D010101167160S	
C24,25	nsp	C,ELECT 10UF-MVG/16V		D050100083460S	
C26,27	nsp	C,CERAMIC 0.01UF-K/50V		D011103777160S	
C28H	nsp	C,ELECT 10UF-MVG/16V		D050100083460S	
C29H	nsp	C,ELECT 10UF-MVG/16V		D050100083460S	
C30H	nsp	C,ELECT 10UF-MVG/16V		D050100083460S	
C63-65	nsp	C,CERAMIC 100PF-J/50V		D010101167160S	
C66	nsp	C,CERAMIC 0.01UF-K/50V		D011103777160S	
C86	nsp	C,CERAMIC 0.047UF-Z/50V		D011473597160S	
C87,88	nsp	C,CERAMIC 0.01UF-K/50V		D011103777160S	
C831D	nsp	C,CERAMIC 0.1UF-K/50V		D011104577162S	
C832D	nsp	C,CERAMIC 1000PF-K/50V		D011102177101S	
C833D	nsp	C,CERAMIC 100PF-J/50V		D011101167101S	
C834D	nsp	C,CERAMIC 100PF-J/50V		D011101167101S	

Ref. No.	Part No.	Part Name	Remarks		Q'ty	New
C835D	nsp	C,CERAMIC 0.01UF-K/50V		D011103177101S		
C836D	nsp	C,CERAMIC 0.01UF-K/50V		D011103177101S		
C837D	nsp	C,CERAMIC 100PF-J/50V		D011101167101S		
C838D	nsp	C,CERAMIC 100PF-J/50V		D011101167101S		
C839D	nsp	C,CERAMIC 100PF-J/50V		D011101167101S		
C840D	nsp	C,CERAMIC 100PF-J/50V		D011101167101S		
C841D	nsp	C,CERAMIC 100PF-J/50V		D011101167101S		
C842D	nsp	C,CERAMIC 100PF-J/50V		D011101167101S		
C843D	nsp	C,CERAMIC 100PF-J/50V		D011101167101S		
C844D	nsp	C,CERAMIC 100PF-J/50V		D011101167101S		
C845D	nsp	C,CERAMIC 0.1UF-K/50V		D011104177101S		
C846D	nsp	C,CERAMIC 1000PF-K/50V		D011102177101S		
C847D	nsp	C,CERAMIC 1000PF-K/50V		D011102177101S		
C848D	nsp	C,CERAMIC 1000PF-K/50V		D011102177101S		
C849D	nsp	C,CERAMIC 1000PF-K/50V		D011102177101S		
C850D	nsp	C,CERAMIC 1000PF-K/50V		D011102177101S		
C851D	nsp	C,CERAMIC 1000PF-K/50V		D011102177101S		
C852D	nsp	C,CERAMIC 1000PF-K/50V		D011102177101S		
C853D	nsp	C,CERAMIC 1000PF-K/50V		D011102177101S		
C854D	nsp	C,CERAMIC 0.1UF-K/50V		D011104177101S		
C855D	nsp	C,CERAMIC 0.1UF-K/50V		D011104177101S		
C856D	nsp	C,CERAMIC 0.1UF-K/50V		D011104177101S		
C857D	nsp	C,CERAMIC 0.1UF-K/50V		D011104177101S		
C858D	nsp	C,CERAMIC 0.1UF-K/50V		D011104177101S		
C859D	nsp	C,CERAMIC 0.1UF-K/50V		D011104177101S		
C860D	nsp	C,CERAMIC 0.1UF-K/50V		D011104177101S		
C861D	nsp	C,CERAMIC 0.1UF-K/50V		D011104177101S		
C862D	nsp	C,CERAMIC 0.01UF-K/50V		D011103177101S		
C863D	nsp	C,CERAMIC 100PF-J/50V		D011101167101S		
C864D	nsp	C,CERAMIC 4.7UF-K/10V		D011475572200S		
C865D	nsp	C,CERAMIC 5PF-C/50V		D010050107160S		
C866D	nsp	C,CERAMIC 5PF-C/50V		D010050107160S		
C871D	nsp	C,CERAMIC 0.01UF-K/50V		D011103177101S		
C873D	nsp	C,CERAMIC 0.01UF-K/50V		D011103177101S		
C875D	nsp	C,CERAMIC 4.7UF-K/10V		D011475572200S		
C876D	nsp	C,CERAMIC 0.01UF-K/50V		D011103177101S		
C877D	nsp	C,CERAMIC 0.1UF-K/50V		D011104177101S		
C878D	nsp	C,CERAMIC 0.1UF-K/50V		D011104177101S		
C879D	nsp	C,CERAMIC 0.1UF-K/50V		D011104177101S		
C880D	nsp	C,CERAMIC 0.01UF-K/50V		D011103177101S		
C881D	nsp	C,CERAMIC 0.01UF-K/50V		D011103177101S		
C882D	nsp	C,CERAMIC 6PF-D/50V		D010060117160S		
C883D	nsp	C,CERAMIC 6PF-D/50V		D010060117160S		
C884D	nsp	C,CERAMIC 0.1UF-K/50V		D011104577162S		
C885D	nsp	C,CERAMIC 0.022UF-Z/50V		D011223597160S		
C886D	nsp	C,CERAMIC 0.1UF-K/50V		D011104177101S		
C887D	nsp	C,FILM 0.12UF-J/63V		D020124078060S		
C888D	nsp	C,CERAMIC 0.01UF-K/50V		D011103177101S		
C889D	nsp	C,CERAMIC 100PF-J/50V		D011101167101S		
C890D	nsp	C,CERAMIC 0.01UF-K/50V		D011103177101S		
C891D	nsp	C,CERAMIC 0.01UF-K/50V		D011103177101S		
C892D	nsp	C,CERAMIC 4.7UF-K/10V		D011475572200S		
C893D	nsp	C,CERAMIC 0.1UF-K/50V		D011104177101S		
C895D	nsp	C,CERAMIC 0.1UF-K/50V		D011104177101S		
C896D	nsp	C,CERAMIC 0.01UF-K/50V		D011103177101S		
C897D	nsp	C,CERAMIC 0.1UF-K/50V		D011104177101S		

Ref. No.	Part No.	Part Name	Remarks		Q'ty	New
C898D	nsp	C,CERAMIC 0.1UF-K/50V		D011104177101S		
C899D	nsp	C,CERAMIC 100PF-J/50V		D011101167101S		
C900D	nsp	C,CERAMIC 4.7UF-K/10V		D011475572200S		
C901D	nsp	C,ELECT 100UF-MVG/6.3V		D050101081650S		
C902D	nsp	C,CERAMIC 0.1UF-K/50V		D011104177101S		
C903D	nsp	C,CERAMIC 0.1UF-K/50V		D011104177101S		
C904D	nsp	C,CERAMIC 5600PF-K/50V		D011562777160S		
C905D	nsp	C,CERAMIC 390PF-J/50V		D010391167160S		
C906D	nsp	C,CERAMIC 0.1UF-K/50V		D011104177101S		
C907D	nsp	C,CERAMIC 0.1UF-K/50V		D011104177101S		
C908D	nsp	C,ELECT 47UF-MVG/6.3V		D050470081460S		
C909D	nsp	C,CERAMIC 0.1UF-K/50V		D011104177101S		
C910D	nsp	C,ELECT 10UF-MVG/16V		D050100083460S		
C911D	nsp	C,CERAMIC 0.01UF-K/50V		D011103177101S		
C913D	nsp	C,ELECT 10UF-MVG/16V		D050100083460S		
C914D	nsp	C,CERAMIC 0.01UF-K/50V		D011103177101S		
C915D	nsp	C,ELECT 10UF-MVG/16V		D050100083460S		
C916D	nsp	C,CERAMIC 0.1UF-K/50V		D011104577162S		
C917D	nsp	C,CERAMIC 0.1UF-K/50V		D011104577162S		
C918D	nsp	C,CERAMIC 0.1UF-K/50V		D011104577162S		
C919D	nsp	C,CERAMIC 0.1UF-K/50V		D011104577162S		
OTHERS PARTS GROUP						
BD801-804	nsp	COIL,BEAD MB-160808		D340160800060S		
BD807D	nsp	COIL,BEAD MB-160808		D340160800060S		
BD808D-02	nsp	COIL,BEAD MB-160808		D340160800060S		
CB03	nsp	R,CHIP THICK 0-J,1/16W		C20000006M160S		
CB06	nsp	COIL,BEAD MB-160808		D340160800060S		
CN01	nsp	CN.WAFER 16P		L101100030910S		
CN802	nsp	CN.HOUSING 16P		L120912160010S		
CN803	nsp	CN.WAFER 16P		L101100031610S		
CN804	nsp	CN.HOUSING 15P		L120912150010S		
CN805	nsp	CN.HOUSING 08P		L120912080010S		
CP404	nsp	CN.WAFER 4P		L101220040000S		
CP405	nsp	CN.WAFER 5P		L101220050000S		
CP406	nsp	CN.WAFER 3P		L101220030000S		
CP904	nsp	CN.WAFER 6P		L101220060010S		
J806	nsp	R,CHIP THICK 0-J,1/16W		C20000006M101S		
JACK01-03	00D 963 0388 504	19PIN HDMI CONNECTOR		L109100190020S		
X803D	nsp	FCX-03(16.660MHz)		00D3991091905		
X804D	nsp	FCX-03(24.576MHz)		00D3991053901		
LUG901	nsp	RING,TER WIRE 70MM/1P		8410700010070S		

D-VIDEO P.W.B. UNIT ASS'Y

Ref. No.	Part No.	Part Name	Remarks	Q'ty	New
SEMICONDUCTORS GROUP					
IC1308,1309	00D 963 0068 002	IC BU4052BCF-E2		J040405200060S	
IC1310	00D 960 0175 200	IC BA7625		J171762500000S	
IC1311,1312	00D 963 0083 304	IC BA7626		J171762600000S	
IC1313	00D 960 0239 104	IC KIA7806API		J126780600130S	
IC1314-1316	00D 963 0148 401	IC LA7956		J171795600010S	
Q1318-1320	00D 960 0005 105	TR KTA1266Y		J5001266Y0050S	
Q1321,1322	00D 960 0005 202	TR KTC3198Y		J5023198Y0000S	
Q1323-1326	00D 963 0121 208	TR KRC107M		J6020107M0010S	
Q1327-1330	00D 960 0005 202	TR KTC3198Y		J5023198Y0000S	
Q1331-1334	00D 963 0121 208	TR KRC107M		J6020107M0010S	
D1306	00D 963 0355 401	D,SWITCHING KDS4148U		K005041480030S	
D1307-1310	00D 276 0401 905	D,SWITCHING 1SS133T		K000013300520S	
D1311,1312	00D 963 0355 401	D,SWITCHING KDS4148U		K005041480030S	
CAPACITORS GROUP					
C1353-1364	nsp	C,CERAMIC 100PF-J/50V		D010101167160S	
C1365	00 D96 3900 596	C,ELECT 4700UF-M/6.3V		D040472081000S	
C1366,1367	00D 960 0298 802	C,ELECT 470UF-M/6.3V		D040471081070S	
C1368-1370	00D 963 0311 607	C,ELECT 100UF-M/10V (Pb Free)		D040101082090S	
C1371-1376	00D 963 0293 602	C,ELECT 1UF-M/50V (Pb Free)		D040010087150S	
C1377	nsp	C,CERAMIC 0.022UF-K/25V		D011223777160S	
C1378	00D 963 0311 607	C,ELECT 100UF-M/10V (Pb Free)		D040101082090S	
C1379	nsp	C,CERAMIC 0.022UF-K/25V		D011223777160S	
C1381	nsp	C,CERAMIC 0.022UF-K/25V		D011223777160S	
C1383	00D 963 0234 205	C,ELECT 10UF-M/50V		D040100087070S	
C1384	00D 963 0234 506	C,ELECT 47UF-M/50V (Pb Free)		D040470087070S	
C1385	00D 963 0234 205	C,ELECT 10UF-M/50V		D040100087070S	
C1386-1394	00D 963 9005 862	C,ELECT 47UF-M/16V		D040470083080S	
C1395-1400	00D 963 9005 901	C,ELECT 470UF-M/10V		D040471082060S	
C1401	00D 960 9010 751	C,ELECT 4.7UF-M/50V		D0404R7087090S	
C1402	nsp	C,CERAMIC 0.047UF-Z/50V		D011473597160S	
C1403	00D 963 0276 409	C,ELECT 100UF-M/16V		D040101083090S	
C1404,1405	nsp	C,CERAMIC 0.047UF-Z/50V		D011473597160S	
C1406,1407	00D 963 0293 602	C,ELECT 1UF-M/50V (Pb Free)		D040010087150S	
C1408,1409	00D 963 0233 303	C,CERAMIC 0.01UF-M/16V		D005103773530S	
C1410-1417	00D 960 9010 751	C,ELECT 4.7UF-M/50V		D0404R7087090S	
OTHERS PARTS GROUP					
CN406	nsp	CN,WIRE 300MM/3P		L000301030060S	
CN1301	nsp	CN.WAFER 8P		L101100030810S	
CN1303	nsp	CN.WAFER 5P		L101220050010S	
CN1305	nsp	CN.WAFER 18P		L101100041810S	
CN1306	nsp	CN.WAFER 19P		L101100041910S	
CP1304	nsp	CN.WAFER 9P		L101100030910S	
CP1305	nsp	CN.WAFER 18P		L101100031810S	
CP1306	nsp	CN.WAFER 19P		L101100031910S	
JACK1305	00D 963 0218 108	TER,RCA 3PIN		G60630401000YS	
JACK1306	00D 963 0218 001	TER,RCA 2PIN		G60122001000YS	

Ref. No.	Part No.	Part Name	Remarks		Q'ty	New
JACK1307-1310	00D 204 6670 010	D-CONNECTOR		L170001200010S		
	nsp	HEAT SINK		2120044338010S		
	nsp	SCREW,TAP TITE +2S 3*8 B-TYPE ZNW/BH		B020030081B10S		

HDMI_PWR P.W.B. UNIT ASS'Y

Ref. No.	Part No.	Part Name	Remarks		Q'ty	New
SEMICONDUCTORS GROUP						
IC401H1	00D9630366500	IC KIA1117PI33		J126111733050S		
CAPACITORS GROUP						
C405H1	00D 963 0234 205	C,ELECT 10UF-M/50V		D040100087070S		
C406H1	00D 963 0233 303	C,CERAMIC 0.01UF-M/16V		D005103773530S		
OTHERS PARTS GROUP						
CN404	nsp	CN,WIRE 300MM/4P		L000301040110S		
CP513	nsp	CN.WAFER 3P ANGLE		L102526803010S		

EXPLODED VIEW (for AVR-1708,AVR-1508 U.S.A.,Canada,Europe & Taiwan R.O.C. model)

WARNING:
Parts marked with this symbol ⚠ have critical characteristics.
Use ONLY replacement parts recommended by the manufacturer.

⚠印の部分は安全を維持するために重要な部品です。従って交換時は必ず指定の部品を使用してください。

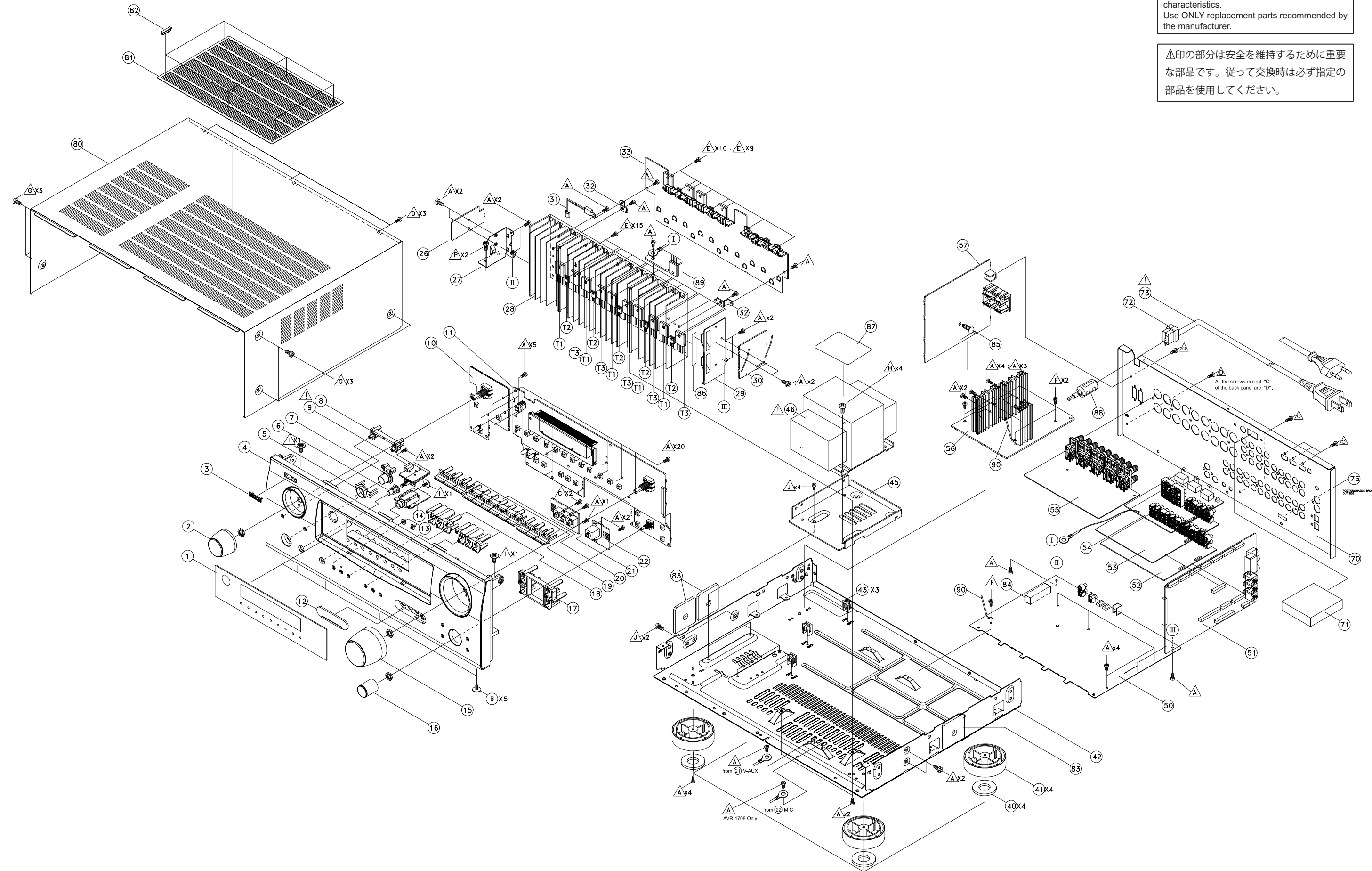

EXPLODED VIEW (for AVR-688,AVR-588,AVR-488 U.S.A. & Canada model)

WARNING:
Parts marked with this symbol  have critical characteristics.
Use **ONLY** replacement parts recommended by the manufacturer.

印の部分は安全を維持するために重要な部品です。従って交換時は必ず指定の部品を使用してください。

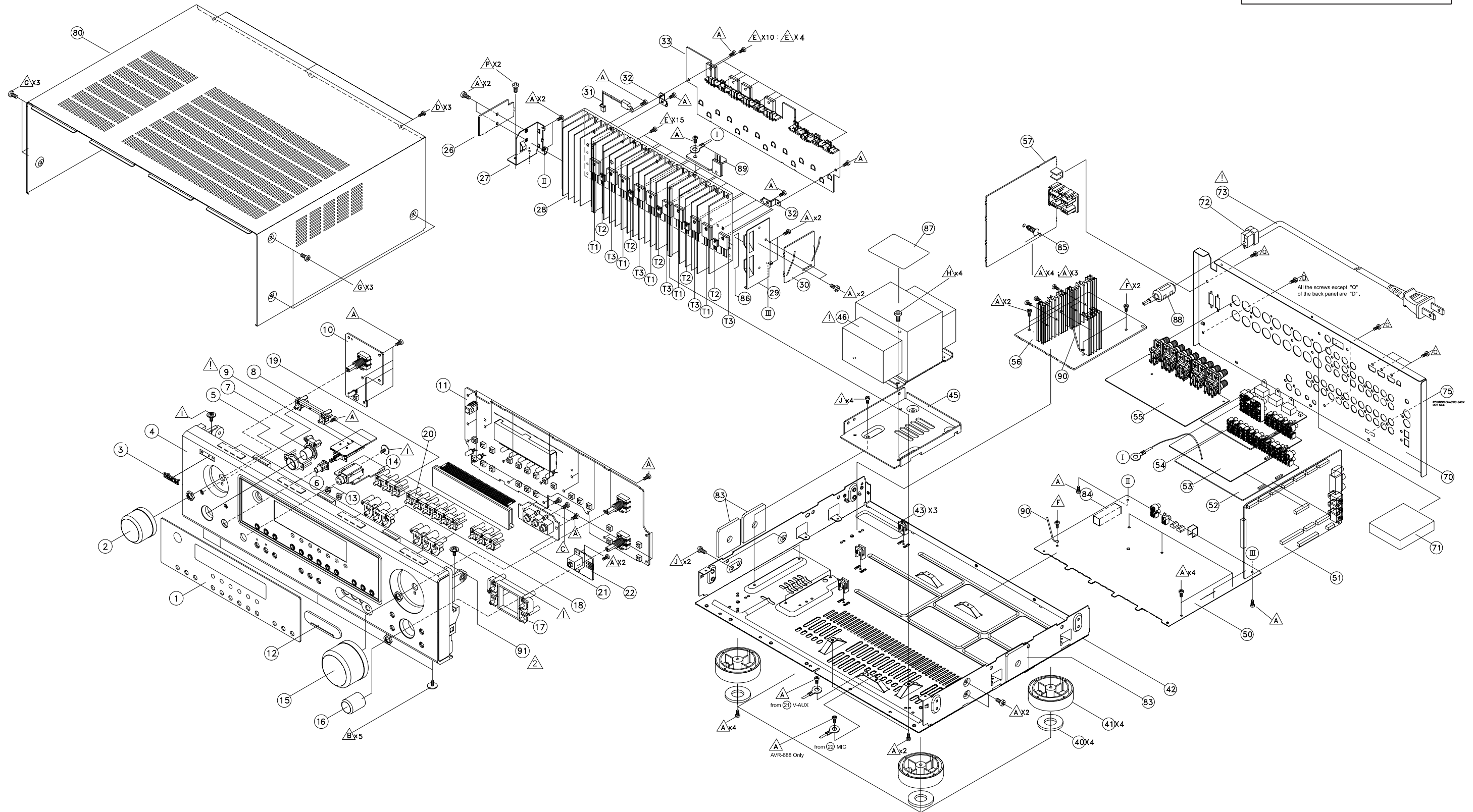

EXPLODED VIEW (for AVC-1508 Japan model)

WARNING:
Parts marked with this symbol  have critical characteristics.
Use **ONLY** replacement parts recommended by the manufacturer.

印の部分は安全を維持するために重要な部品です。従って交換時は必ず指定の部品を使用してください。

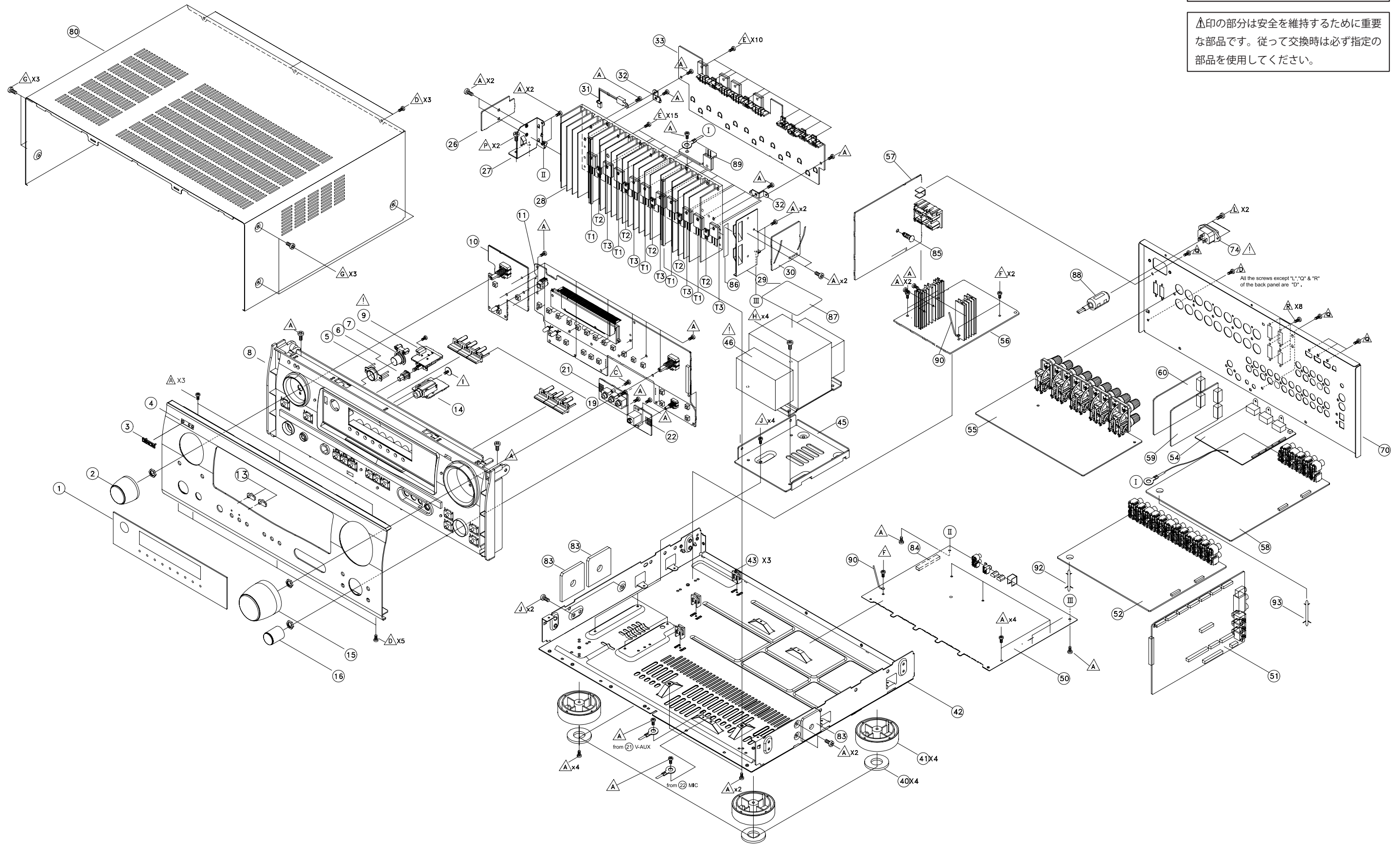

AVR1508SPEUT Measure parts of EMC

1.FRONT P.W.B.

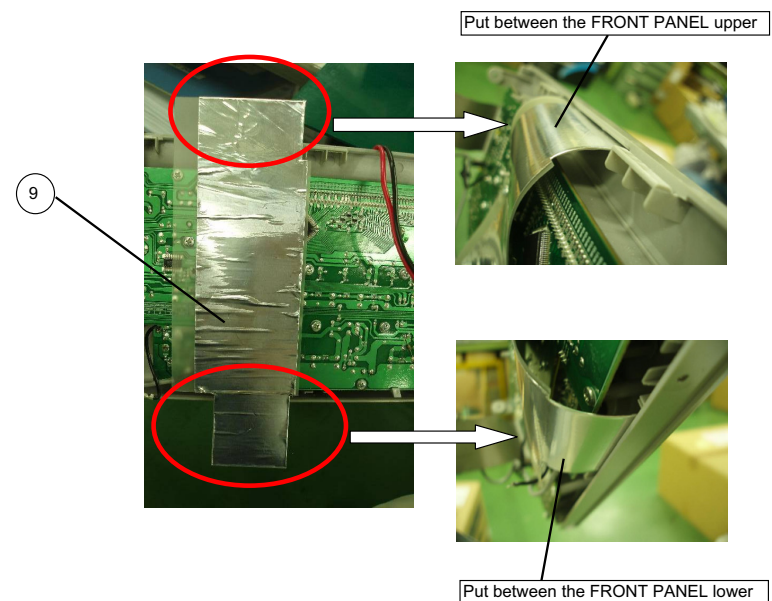

2.HEAT SINK MAIN

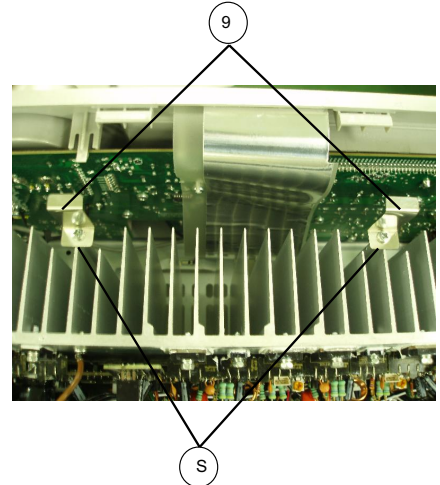

3.CHASSIS MAIN

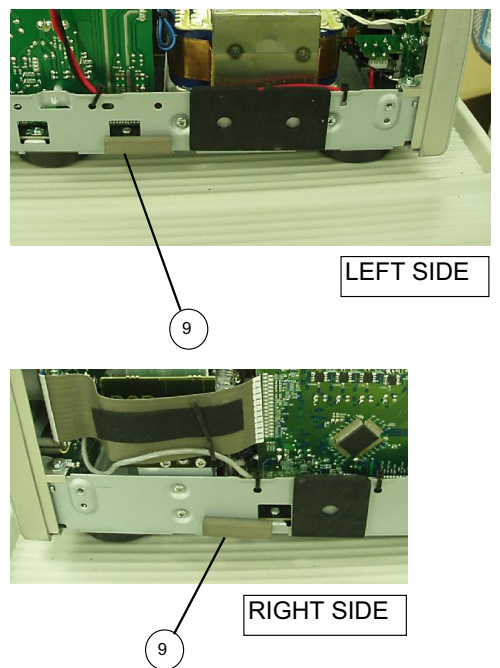

4.TOP COVER

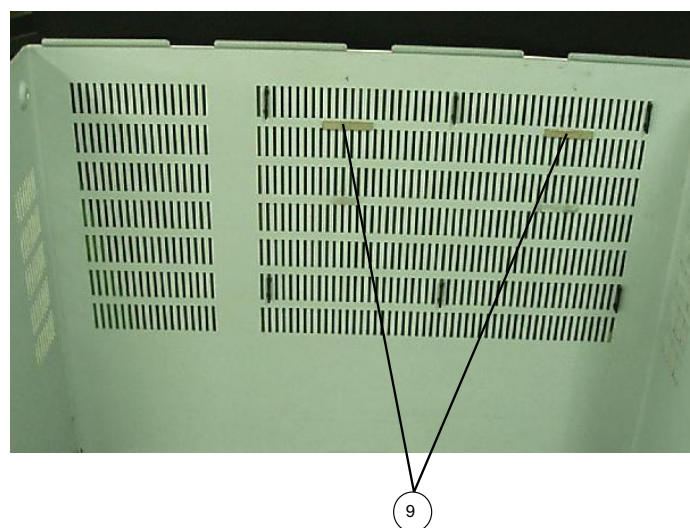

PARTS LIST OF EXPLODED VIEW



* 本表に "nsp" と記載されている部品は供給できません。

* Parts for which "nsp" is indicated on this table cannot be supplied.

* 本表に "nsp" と記載されている基板 ASS'Y は供給できません。基板 ASS'Y の修理の際には基板部品表を確認のうえ、交換部品を発注してください。

* P.W.B. ASS'Y for which "nsp" is indicated on this table cannot be supplied. When repairing the P.W.B. ASS'Y, check the board parts table and order replacement parts.

* 本表に記載されている部品は、補修用部品のため製品に使用している部品とは一部、形状、寸法などが異なる場合があります。

* The parts listed below are for maintenance only, might differ from the parts used in the unit in appearances or dimensions.

Note: The symbols in the column "Remarks" indicate the following destinations.

AVR1708E3 : U.S.A. & Canada model

AVR1708E2 : Europe model

AVR688E3 : U.S.A. & Canada model

AVR1508E3 : U.S.A. & Canada model

AVR1508E2 : Europe model

AVR1508EUT : Taiwan R.O.C. model

AVR588E3 : U.S.A. & Canada model

AVR 488E3 : U.S.A. & Canada model

AVC1508JP : Japan model

Black : Black model

Premium Silver : Premium Silver model

Silver : Silver model

Ref. No.	Part No.	Part Name	Remarks		Q'ty	New
57A	nsp	POWER P.W.B. ASSY	AVR1708E3	7025HK0705013	1	*
57A	nsp	POWER P.W.B. ASSY	AVR688E3	7025HK0705023	1	*
57A	nsp	POWER P.W.B. ASSY	AVR1708E2	7025HK0705033	1	*
57A	nsp	POWER P.W.B. ASSY	AVR1508E3	7025HK0704023	1	*
57A	nsp	POWER P.W.B. ASSY	AVR588E3	7025HK0704033	1	*
57A	nsp	POWER P.W.B. ASSY	AVR1508E2	7025HK0704043	1	*
57A	nsp	POWER P.W.B. ASSY	AVR1508EUT	7025HK0704053	1	*
57A	nsp	POWER P.W.B. ASSY	AVC1508JP	7025HK0704063	1	*
57A	nsp	POWER P.W.B. ASSY	AVR488E3	7025HK0704013	1	*
26		GUIDE L				
30		GUIDE R				
56		POWER SUPPLY ASSY				
57		POWER ASSY				
11A	nsp	FRONT P.W.B. ASSY	AVR1708E3	7025HK0705011	1	*
11A	nsp	FRONT P.W.B. ASSY	AVR688E3	7025HK0705021	1	*
11A	nsp	FRONT P.W.B. ASSY	AVR1708E2	7025HK0705031	1	*
11A	nsp	FRONT P.W.B. ASSY	AVR1508E3	7025HK0704021	1	*
11A	nsp	FRONT P.W.B. ASSY	AVR588E3	7025HK0704031	1	*
11A	nsp	FRONT P.W.B. ASSY	AVR1508E2	7025HK0704041	1	*
11A	nsp	FRONT P.W.B. ASSY	AVR1508EUT	7025HK0704051	1	*
11A	nsp	FRONT P.W.B. ASSY	AVC1508JP	7025HK0704061	1	*
11A	nsp	FRONT P.W.B. ASSY	AVR488E3	7025HK0704011	1	*
9		POWER SW ASSY				
10		FUNCTION ASSY				
11		FRONT ASSY				
14		HEAD PHONE ASSY				
21		V- AUX ASSY				
22		MIC ASSY	except for AVR1508E3/ AVR1508EUT/AVR588E3/ AVC488E3			
55		SPEAKER ASSY				
50A	nsp	MAIN P.W.B ASSY	AVR1708E3	7025HK0705010	1	*
50A	nsp	MAIN P.W.B ASSY	AVR688E3	7025HK0705020	1	*
50A	nsp	MAIN P.W.B ASSY	AVR1708E2	7025HK0705030	1	*
50A	nsp	MAIN P.W.B ASSY	AVR1508E3	7025HK0704020	1	*
50A	nsp	MAIN P.W.B ASSY	AVR588E3	7025HK0704030	1	*
50A	nsp	MAIN P.W.B ASSY	AVR1508E2	7025HK0704040	1	*
50A	nsp	MAIN P.W.B ASSY	AVR1508EUT	7025HK0704050	1	*
50A	nsp	MAIN P.W.B ASSY	AVC1508JP	7025HK0704060	1	*
50A	nsp	MAIN P.W.B ASSY	AVR488E3	7025HK0704010	1	*
50		P.C.B MAIN ASSY				

Ref. No.	Part No.	Part Name	Remarks		Q'ty	New
51A	nsp	CPU P.W.B. ASSY	AVR1708E3	7025HK0705015	1	*
51A	nsp	CPU P.W.B. ASSY	AVR688E3	7025HK0705025	1	*
51A	nsp	CPU P.W.B. ASSY	AVR1708E2	7025HK0705035	1	*
51A	nsp	CPU P.W.B. ASSY	AVR1508E3	7025HK0704025	1	*
51A	nsp	CPU P.W.B. ASSY	AVR588E3	7025HK0704035	1	*
51A	nsp	CPU P.W.B. ASSY	AVR1508E2	7025HK0704045	1	*
51A	nsp	CPU P.W.B. ASSY	AVR1508EUT	7025HK0704055	1	*
51A	nsp	CPU P.W.B. ASSY	AVC1508JP	7025HK0704065	1	*
51A	nsp	CPU P.W.B. ASSY	AVR488E3	7025HK0704015	1	*
51		CPU ASSY			1	
52A	nsp	INPUT P.W.B. ASSY	AVR1708E3	7025HK0705012	1	*
52A	nsp	INPUT P.W.B. ASSY	AVR688E3	7025HK0705022	1	*
52A	nsp	INPUT P.W.B. ASSY	AVR1708E2	7025HK0705032	1	*
52A	nsp	INPUT P.W.B. ASSY	AVR1508E3	7025HK0704022	1	*
52A	nsp	INPUT P.W.B. ASSY	AVR588E3	7025HK0704032	1	*
52A	nsp	INPUT P.W.B. ASSY	AVR1508E2	7025HK0704042	1	*
52A	nsp	INPUT P.W.B. ASSY	AVR1508EUT	7025HK0704052	1	*
52A	nsp	INPUT P.W.B. ASSY	AVC1508JP	7025HK0704062	1	*
52A	nsp	INPUT P.W.B. ASSY	AVR488E3	7025HK0704012	1	*
52		INPUT ASSY				
53A	nsp	VIDEO P.W.B. ASSY	AVR1708E3	7025HK0705017	1	*
53A	nsp	VIDEO P.W.B. ASSY	AVR688E3	7025HK0705027	1	*
53A	nsp	VIDEO P.W.B. ASSY	AVR1708E2	7025HK0705037	1	*
53A	nsp	VIDEO P.W.B. ASSY	AVR1508E3	7025HK0704028	1	*
53A	nsp	VIDEO P.W.B. ASSY	AVR588E3	7025HK0704038	1	*
53A	nsp	VIDEO P.W.B. ASSY	AVR1508E2	7025HK0704048	1	*
53A	nsp	VIDEO P.W.B. ASSY	AVR1508EUT	7025HK0704058	1	*
53A	nsp	VIDEO P.W.B. ASSY	AVR488E3	7025HK0704018	1	*
53		VIDEO ASSY				
54A	00D9630368700	HDMI P.W.B. ASSY	AVR1708E3/AVR688E3/ AVR1508E3/AVR588E3/ AVR488E3	7025HK0705016	1	*
54		HDMI ASSY				
54B	00D9630368807	HDMI P.W.B. ASSY	AVR1708E2/ AVR1508E2/ AVR1508EUT/ AVC1508JP	7025HK0705036	1	*
54		HDMI ASSY				
33A	nsp	2CH P.W.B. ASSY	AVR1708E3	7025HK0705014	1	*
33A	nsp	2CH P.W.B. ASSY	AVR688E3	7025HK0705024	1	*
33A	nsp	2CH P.W.B. ASSY	AVR1708E2	7025HK0705034	1	*
33A	nsp	2CH P.W.B. ASSY	AVR1508E3	7025HK0704024	1	*
33A	nsp	2CH P.W.B. ASSY	AVR588E3	7025HK0704034	1	*
33A	nsp	2CH P.W.B. ASSY	AVR1508E2	7025HK0704044	1	*
33A	nsp	2CH P.W.B. ASSY	AVR1508EUT	7025HK0704054	1	*
33A	nsp	2CH P.W.B. ASSY	AVC1508JP	7025HK0704064	1	*
33		2CH ASSY				
33B	nsp	2CH POWER P.W.B ASSY	AVR488E3	7025HK070401A	1	*
33		SUB ASSY				

Ref. No.	Part No.	Part Name	Remarks		Q'ty	New
58A	nsp	D-VIDEO P.W.B. ASSY	AVC1508JP	7025HK0704069	1	*
58		VIDEO ASSY				
59		D-VIDEO1 ASSY				
60		D-VIDEO2 ASSY				
1	00D9630358509	WINDOW	AVR1708E3	5077212382000S	1	*
1	00D9630358602	WINDOW	AVR688E3	5077211922200S	1	*
1	00D9630358705	WINDOW	AVR1708E2	5077212382010S	1	*
1	00D9630358808	WINDOW	AVR1508E3	5077212382030S	1	*
1	00D9630358901	WINDOW	AVR588E3	5077211922220S	1	*
1	00D9630359007	WINDOW	AVR1508E2	5077212382010S	1	*
1	00D9630359100	WINDOW	AVR1508EUT	5077212382040S	1	*
1	00D9630359203	WINDOW	AVC1508JP	5077212382050S	1	*
1	00D9630359306	WINDOW	AVR488E3	5077211922210S	1	*
2	00D9630361704	KNOB FUNCTION	AVR1708E3/BKE2/ AVR1508E3	5087211461000S	1	*
2	00D9630138301	KNOB FUNCTION	AVR688E3/588E3/488E3	5087210961000S	1	*
2	00D9630361807	KNOB FUNCTION	AVR1708SRE2/ AVR1508SRE2	5087211461100S	1	*
2	00D9630361900	KNOB FUNCTION	AVR1508EUT	5087211461110S	1	*
2	00D9630362006	KNOB FUNCTION	AVC1508JP	5088211508020SZ	1	*
3	00D9630362109	BADGE	Black	5630210028300S	1	*
3	00D9630051527	BADGE	Silver	5630210028200S	1	*
3	00D9630362202	BADGE	Premium Silver	5630210028400S	1	*
4	00D9630359409	PANEL FRONT	AVR1708E3	3067213241000S	1	*
4	00D9630359502	PANEL FRONT	AVR688E3	3067213271010S	1	*
4	00D9630359605	PANEL FRONT	AVR1708BKE2	3067213241400S	1	*
4	00D9630359708	PANEL FRONT	AVR1708SRE2	3067213241100S	1	*
4	00D9630359801	PANEL FRONT	AVR1508E3	3067213241200S	1	*
4	00D9630359904	PANEL FRONT	AVR588E3	3067213271110S	1	*
4	00D9630360000	PANEL FRONT	AVR1508E2	3067213241110S	1	*
4	00D9630360103	PANEL FRONT	AVR1508EUT	3067213241300S	1	*
4	00D9630360206	PANEL FRONT	AVC1508JP	3067213258030S	1	*
4	00D9630360309	PANEL FRONT	AVR488E3	3067213271100S	1	*
5	00D9630137807	LENS STANDBY		3710210503000S	1	
6	00D9630184009	BUTTON POWER	Black	5097212358000SZ	1	
6	00D9630139805	BUTTON POWER	Silver	5097212358100SZ	1	
6	00D9630230005	BUTTON POWER	Premium Silver	5097212358300SZ	1	
7	00D9630184106	BUTTON STANDBY	Black	5097212368000SZ	1	
7	00D9630140108	BUTTON STANDBY	Silver	5097212368010SZ	1	
7	00D9630221904	BUTTON STANDBY	Premium Silver	5097212368030SZ	1	
8	00D9630361601	FRAME FRONT	AVC1508JP	3217211521200S	1	*
8	00D9630362305	BUTTON 2KEY	Black	5097213351000S	1	*
8	00D9630362408	BUTTON 2KEY	Silver	5097213351100S	1	*
8	00D9630362501	BUTTON 2KEY	Premium Silver (except for AVC1508JP)	5097213351110S	1	*
12	00D9630190200	COVER RCA	Black	4317211701000S	1	
12	00D9630190307		Silver	4317211701100S	1	
12	00D9630239705		Premium Silver (except for AVC1508JP)	4317212231110S	1	
13	00D9600191417	LENS LED		3710210043001S	2	
15	00D9630362604	KNOB VOLUME	AVR1708E3/BKE2/ AVR1508E3	5087211471000S	1	*
15	00D9630138806	KNOB VOLUME	AVR688E3/AVR588E3/ AVR488E3	5087210981000S	1	*
15	00D9630362707	KNOB VOLUME	AVR1708SRE2/ AVR1508SRE2	5087211471100S	1	*
15	00D9630362800	KNOB VOLUME	AVR1708EUT	5087211471110S	1	*

	Ref. No.	Part No.	Part Name	Remarks		Q'ty	New
	15	00D9630362903	KNOB VOLUME	AVC1508JP	5088211498020SZ	1	*
	16	00D9630363009	KNOB SELECT	AVR1708E3/BKE2/ AVR1508E3	5087211481000S	1	*
	16	00D9630344302	KNOB SELECT	AVR688E3/AVR588E3/ AVR488E3	5087211281000S	1	*
	16	00D9630364102	KNOB SELECT	AVR1708SRE2/ AVR1508SRE2	5087211481100S	1	*
	16	00D9630364205	KNOB SELECT	AVR1708EUT	5087211481110S	1	*
	16	00D9630364308	KNOB SELECT	AVC1508JP	5088211518020SZ	1	*
	17	00D9630364401	BUTTON 4KEY	AVR1708E3/BKE2/ AVR1508E3	5097213341000S	1	*
	17	00D9630139407	BUTTON 4KEY	AVR688E3/AVR588E3/ AVR488E3	5097212341000S	1	*
	17	00D9630364504	BUTTON 4KEY	AVR1708SRE2/ AVR1508SRE2	5097213341100S	1	*
	17	00D9630364607	BUTTON 4KEY	AVR1708EUT	5097213341110S	1	*
	18	00D9630364700	BUTTON 3KEY	AVR1708E3/BKE2/ AVR1508E3	5097213331000S	2	*
	18	00D9630139106	BUTTON 3KEY	AVR688E3/AVR588E3/ AVR488E3	5097212331000S	2	*
	18	00D9630364803	BUTTON 3KEY	AVR1708SRE2/ AVR1508SRE2	5097213331100S	2	*
	18	00D9630364906	BUTTON 3KEY	AVR1708EUT	5097213331110S	2	*
	19	00D9630365002	BUTTON WIN 3KEY	AVR1708E3/BKE2/ AVR1508E3	5097213371000S	2	*
	19	00D9630365105	BUTTON WIN 3KEY	AVR688E3/AVR588E3/ AVR488E3	5090213391000S	2	*
	19	00D9630365208	BUTTON WIN 3KEY	AVR1708SRE2/ AVR1508SRE2	5097213371100S	2	*
	19	00D9630365301	BUTTON WIN 3KEY	AVR1708EUT/ AVC1508JP	5097213371110S	2	*
	20	00D9630365404	BUTTON WIN 6KEY	AVR1708E3/BKE2/ AVR1508E3	5097213361000S	1	
	20	00D9630365507	BUTTON WIN 6KEY	AVR688E3/AVR588E3/ AVR488E3	5090213381000S	1	
	20	00D9630365600	BUTTON WIN 6KEY	AVR1708SRE2/ AVR1508SRE2	5097213361100S	1	
	20	00D9630365703	BUTTON WIN 6KEY	AVR1708EUT/ AVC1508JP	5097213361110S	1	
	27	nsp	BRACKET HEATSINK L		4010213146000S	1	*
	28	nsp	HEAT SINK MAIN	except for AVR488E3	2120211138000S	1	*
	28	nsp	HEAT SINK MAIN	AVR488E3	2120211148000S	1	*
	29	nsp	BRACKET HEATSINK R		4010213136000S	1	*
	31	nsp	POSISTOR P437D330BW16		F320161001020S	1	
	32	nsp	BRACKET PCB		4010210186000S	2	
	40	00D9630214607	CUSHION FOOT		4050211295000S	4	
	41	00D9630137904	FOOT		4007210261000S	4	
	42	nsp	CHASSIS MAIN		3200212146000S	1	*
	43	nsp	SUPPORTER PCB		4070001601010S	3	
	45	nsp	BRACKET TRANS		4010210466002S	1	
⚠	46	00D9630367905	POWER TRANS MAIN	AVR1708E3/AVR688E3	8200960660240S	1	
⚠	46	00D9630368001	POWER TRANS MAIN	AVR1708E2	8200960660250S	1	
⚠	46	00D9630368108	POWER TRANS MAIN	AVR1508E3/ AVR1508EUT/AVR588E3	8200960660260S	1	
⚠	46	00D9630368205	POWER TRANS MAIN	AVR1508E2	8200960660270S	1	
⚠	46	00D9630368302	POWER TRANS MAIN	AVR1508JP	8200960660290S	1	
⚠	46	00D9630368409	POWER TRANS MAIN	AVR488E3	8200960660280S	1	
	70	00D9630360402	CHASSIS BACK	AVR1708E3	3207212156502S	1	*
	70	00D9630360505	CHASSIS BACK	AVR688E3	3207212156512S	1	*
	70	00D9630360608	CHASSIS BACK	AVR1708E2	3207212156600S	1	*

	Ref. No.	Part No.	Part Name	Remarks		Q'ty	New
	70	00D9630360701	CHASSIS BACK	AVR1508E3	3207212156803S	1	*
	70	00D9630360804	CHASSIS BACK	AVR588E3	3207212156A03S	1	*
	70	00D9630389909	CHASSIS BACK	AVR1508E2	3207212156611S	1	*
	70	00D9630361003	CHASSIS BACK	AVR1508EUT	3207212156700S	1	*
	70	00D9630361106	CHASSIS BACK	AVC1508JP	3207212156401S	1	*
	70	00D9630361209	CHASSIS BACK	AVR488E3	3207212156903S	1	*
	71	00D9630145608	TUNER PACK	AVR1708E3/AVR688E3/ AVR1508E3/AVR588E3/ AVR488E3	E903014000020S	1	*
	71	00D9630145705	TUNER PACK	AVR1708E2/ AVR1508E2/ AVR1508EUT	E903014100030S	1	*
	72	00D9600192403	STOPPER CORD AC	except for AVC1508JP	4380210002000S	1	
⚠	73	00D9630292205	AC CORD	AVR1708E3/AVR688E3/ AVR1508E3/AVR588E3/ AVR488E3	L068125100020S	1	
⚠	73	00D9630292409	AC CORD	AVR1708E2/AVR1508E2	L068250250040S	1	
⚠	73	00D9630292302	AC CORD	AVR1508EUT	L068125110000S	1	
	74	00D9630158404	AC INLET	AVC1508JP	G430040560020S	1	
	75	nsp	LABEL ORIGIN	AVR1508EUT	5507003020021S	1	
	80	00D9630361302	CABINET TOP	Black	3000210936000S	1	*
	80	00D9630361405	CABINET TOP	Silver/Premium Silver	3000210936100S	1	*
	80	00D9630361508	CABINET TOP	AVC1508JP	3000210926100S	1	*
	81	nsp	COVER SAFETY	E2, EUT model	4310212122010S	1	*
	82	nsp	COVER HOLDER	E2, EUT model	4310213701000S	1	*
	83	nsp	CUSHION SIDE		4050211095000S	1	*
	84	nsp	CUSHION PCB	except for AVC1508JP	4050211095000S	1	*
	84	nsp	CUSHION PCB	AVC1508JP	4050211105000S	1	*
	85	nsp	SUPPORTER BUTTON LOCK		4070000020000S	1	*
	86	nsp	LABEL RATING FUSE CAUTION	for only E3 model	5527042410030S	1	
	87	nsp	LABEL(TRANS)		5507051740120S	1	
	88	00D3420043000	FERRITE CLAMP102010N			1	
	89	nsp	HDMI PWR ASSY		7025HK0705018	1	*
	90	nsp	CLAMP(MTG)		4330000310000S	2	
	91	nsp	SHEET CABINET	AVR688E3/AVR588E3/ AVR488E3	1210210235000S	4	*
	92	nsp	SUPPORTER	AVC1508JP	4070211583000S	1	*
	93	nsp	SUPPORTER	AVC1508JP	4070000340000S	1	*
	91	00D9630365806	CABLE,FLAT CARD 1.25MM		N712151344810S	1	*
	92	00D9630365909	CABLE,FLAT CARD 1.25MM	except for AVC1508JP	N712351534810S	1	*
	96	nsp	INSULATION SHEET	AVR1508EUT	1240210099000S	1	
	97	nsp	PLATE EARTH	AVR1508EUT	4470211366000S	2	
	98	nsp	GASKET EMC A(30*10*T6)	AVR1508EUT	4400210179000S	2	
	99	nsp	GASKET EMC B(30*5*T2)	AVR1508EUT	4400210189000S	2	
	T1	00D9630044107	TR PNP 2SB1560-Y	Q102 FL/FR/C/SL/SR	J5011560Y0000S	5	*
	T2	00D9630280107	TR NPN 2SC3964	Q103 FL/FR/C/SL/SR	J502396400000S	5	*
	T3	00D9630044204	TR NPN 2SD2390-Y	Q101 FL/FR/C/SL/SR	J5032390Y0000S	5	*
Screws							
	A	nsp	SCREW(3X8 B-TYPE ZNY/BH)	AVR1708E3/ AVR1708E2/ AVR1508E2/AVR688E3	B020030081B10S	66	
	A	nsp	SCREW(3X8 B-TYPE ZNY/BH)	AVR1508E3/ AVR1508EUT/ AVR588E3/AVR488E3		63	
	A	nsp	SCREW(3X8 B-TYPE ZNY/BH)	AVC1508JP		73	
	B	nsp	SCREW(3X8 BK WASHER PI12)	Black	1500001456020S	5	



Ref. No.	Part No.	Part Name	Remarks		Q'ty	New
B	nsp	SCREW(3X8 BK WASHER NI12)	Silver / Premium Silver	1500001456030S	5	
C	nsp	SCREW(3X15 B-TYPE ZNY/BH)		B020030151B10S	2	
D	nsp	SCREW(3X10 B-TYPE(DOT) BK/BH)	AVR1708E3/AVR688E3/ AVC1508JP	B020030103B11S	36	
D	nsp	SCREW(3X10 B-TYPE(DOT) BK/BH)	AVR1708E2/ AVR1508E3/ AVR1508E2/ AVR1508EUT/AVR588E3		35	
D	nsp	SCREW(3X10 B-TYPE(DOT) BK/BH)	AVR488E3		34	
E	nsp	SCREW(3X14 P+S-WASHER ZNY/HH)	AVR1708E3/AVR688E3/ AVR1508E3/AVR588E3	B018230141H11S	25	
E	nsp	SCREW(3X14 P+S-WASHER ZNY/HH)	AVR1708E2/ AVR1508E2/ AVR1508EUT/ AVC1508JP		24	
E	nsp	SCREW(3X14 P+S-WASHER ZNY/HH)	AVR488E3		19	
F	nsp	SCREW(3X17 B-TYPE ZNY/BH)		B020030171B10S	3	
G	00D9630048307	SCREW(4X8 B-TYPE(DOT) BK/BH)	Black	1500040083B10S	6	
G	00D9639004012	SCREW(4X8 B-TYPE(DOT) NI/BH)	Silver / Premium Silver	1500040084B10S	6	
H	nsp	SCREW(4X10 P+S-WASHER ZNY/BH)		B028940101B10S	4	
I	nsp	SCREW(3X8 ZnY WASHER PI12)		1500001456010S	3	
J	nsp	SCREW(4X6 S-TYPE ZNY/BH)		B020740061B10S	6	
L	nsp	SCREW(3X10 B-TYPE BK/FH)	AVC1508JP	B020030103F10S	2	
P	nsp	SCREW(3X8 S-TYPE BK/BH)		B020030063B10S	2	
Q	nsp	SCREW(3X8 S-TYPE BK/BH)		B020930083B10S	5	
R	nsp	SCREW(2*8 B-TYPE BLACK/BH)	AVC1508JP	B020020081B10S	8	
S	nsp	SCREW(3X8 B-TYPE ZNW/BH(2EA)	AVR1508EUT	B020030081B10S	2	

PACKING VIEW

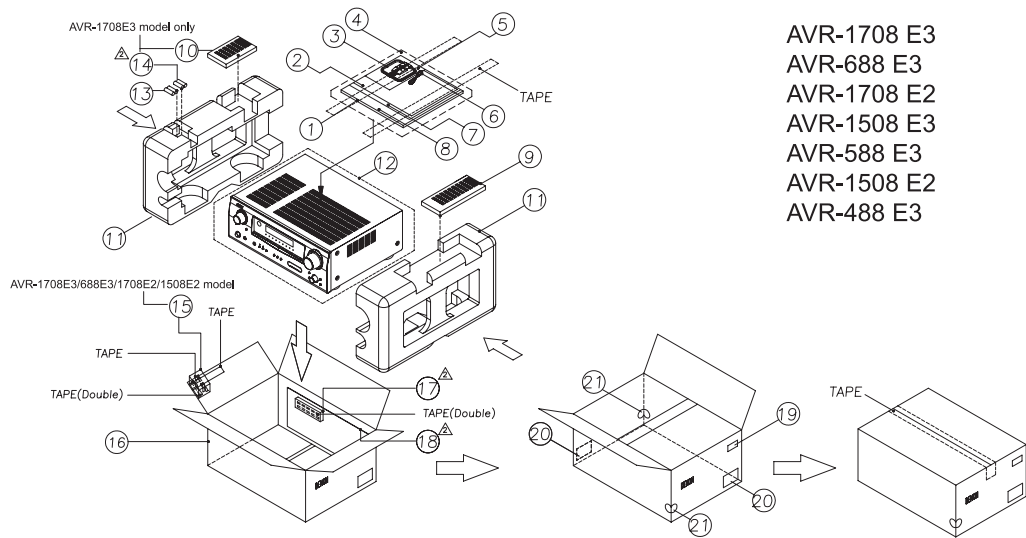

AVR-1508 EUT

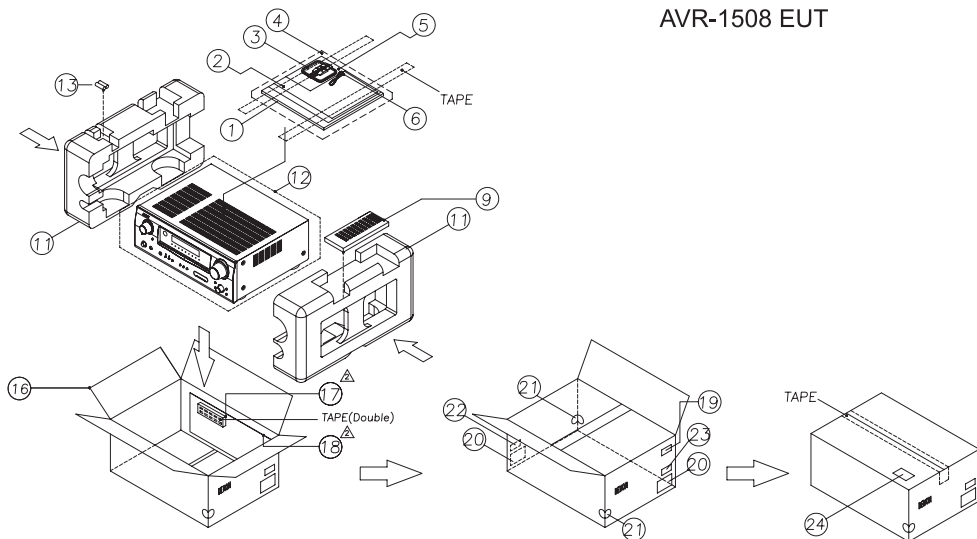

AVC-1508 JP

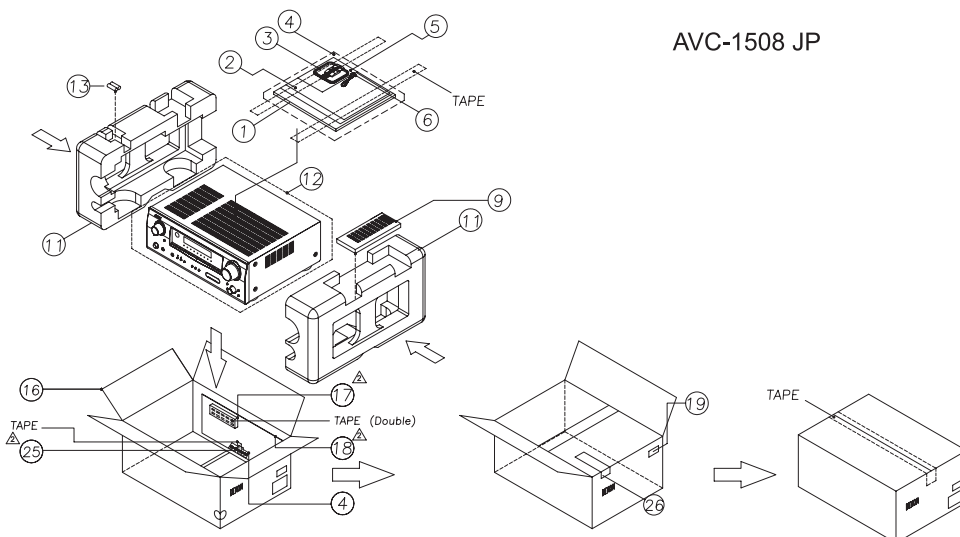

PARTS LIST OF PACKING & ACCESSORIES

3

* 本表に "nsp" と記載されている部品は供給できません。

* Parts for which "nsp" is indicated on this table cannot be supplied.

* 本表に記載されている部品は、補修用部品のため製品に使用している部品とは一部、形状、寸法などが異なる場合があります。

* The parts listed below are for maintenance only, might differ from the parts used in the unit in appearances or dimensions.

Note: The symbols in the column "Remarks" indicate the following destinations.

AVR1708E3 : U.S.A. & Canada model AVR1708E2 : Europe model AVR688E3 : U.S.A. & Canada model

AVR1508E3 : U.S.A. & Canada model AVR1508E2 : Europe model AVR1508EUT : Taiwan R.O.C. model

AVR588E3 : U.S.A. & Canada model AVR 488E3 : U.S.A. & Canada model

AVC1508JP : Japan model

Black : Black model

Premium Silver : Premium Silver model

Silver : Silver model

Ref. No.	Part No.	Part Name	Remarks	Q'ty	New
1	00D9630388908	INSTRUCTION MANUAL	AVR1708E3	5707210120071S	1 *
1	00D9630389002	INSTRUCTION MANUAL	AVR688E3	5707210120081S	1 *
1	00D9630389105	INSTRUCTION MANUAL	AVR1708E2	5707210120091S	1 *
1	00D9630389208	INSTRUCTION MANUAL	AVR1508E3	5707210120111S	1 *
1	00D9630389301	INSTRUCTION MANUAL	AVR588E3	5707210120121S	1 *
1	00D9630389404	INSTRUCTION MANUAL	AVR1508E2	5707210120131S	1 *
1	00D9630357300	INSTRUCTION MANUAL	AVR1508EUT	5707210120140S	1 *
1	00D9630389507	INSTRUCTION MANUAL	AVR1508JP	5707210120151S	1 *
1	00D9630389600	INSTRUCTION MANUAL	AVR488E3	5707210120101S	1 *
2	nsp	WARRANTY CARD	E3 model	5777001610038S	1
2	nsp	WARRANTY CARD NOTICE SHEET	only AVC1508JP	5727001130021S	1
3	00D2310089007	AM LOOP ANTENNA	for except AVC1508JP	E605010110010S	1
4	nsp	POLY BAG		6330000240000S	1
5	nsp	S.S LIST		577700162001BS	1
5	nsp	SVC STATION LIST	only AVC1508JP	5777200040019S	1
6	00D9630158006	FM ANTENNA WIRE	for except AVC1508JP	E605010070001S	1
7	nsp	SHEET(ASD1R)	for except AVR1508EUT	5227000000340S	1
7	nsp	SHEET(ASD1R)	AVC1508JP	5227000000350S	1
8	nsp	XM SHEET	E3 model	5227000000200S	1 *
9	00D3991105008	REMOTE CONTROL RC-1075	E3 model		1 *
9	00D3991106007	REMOTE CONTROL RC-1076	E2 / EUT model		1 *
9	00D3991109004	REMOTE CONTROL RC-1079	AVR488E3		1 *
10	00D9630366809	REMOTE CONTROL RC-1085	AVR1708E3	8300107500010S	1 *
11	00D9630366902	CUSHION,SNOW		6230211924000S	1 *
12	00D9630241405	POLY BAG SET		6327040059000S	1
13	nsp	BATTERY DRY		G670001R50190S	2
14	nsp	BATTERY DRY	RC-1085		2
15	00D3210040006	MIC CONDESER DM-A405EM	AVR1708E3/AVR688E3/ AVR1708E2/AVR1508E2		1 *
16	00D9630357609	BOX,GIFT	AVR1708E3	6007211030060S	1 *
16	00D9630357702	BOX,GIFT	AVR688E3	6007211030070S	1 *
16	00D9630357805	BOX,GIFT	AVR1708E2	6007211030080S	1 *
16	00D9630357908	BOX,GIFT	AVR1508E3	60072110300A0S	1 *
16	00D9630358004	BOX,GIFT	AVR588E3	60072110300B0S	1 *
16	00D9630358107	BOX,GIFT	AVR1508E2	60072110300C0S	1 *
16	00D9630358200	BOX,GIFT	AVR1508EUT	60072110300E0S	1 *
16	00D9630358303	BOX,GIFT	AVC1508JP	60072110300F0S	1 *
16	00D9630358406	BOX,GIFT	AVR488E3	6007211030090S	1 *
17	nsp	PAD FRONT		6240210474000S	1 *
18	nsp	PAD BOX		6240210460000S	1 *
19	nsp	UPC LABEL	AVR1708E3	5507002370060S	1 *
19	nsp	UPC LABEL	AVR688E3	5507002370070S	1 *
19	nsp	UPC LABEL	AVR1708BKE2	5507002370080S	1 *
19	nsp	UPC LABEL	AVR1708SRE2	5507002370090S	1 *
19	nsp	UPC LABEL	AVR1508E3	5507002370110S	1 *

Ref. No.	Part No.	Part Name	Remarks		Q'ty	New	
	19	nsp	UPC LABEL	AVR588E3	5507002370120S	1	*
	19	nsp	UPC LABEL	AVR1508BKE2	5507002370130S	1	*
	19	nsp	UPC LABEL	AVC1508JP	5507002370140S	1	*
	19	nsp	UPC LABEL	AVR488E3	5507002370100S	1	*
	20	nsp	CONTROL CARD		5500014920010S	2	
	21	00D9630110303	COLOR LABEL(SILVER)	Silver model	5507020170340S	2	
	21	00D9630230209	COLOR LABEL(PREMIUM SILVER)	Premium Silver model	5507020170680S	2	
	22	nsp	LABEL BOX (made in china)-1	AVR1508EUT	5507003010040S	1	
	23	nsp	LABEL BOX (made in china)-2	AVR1508EUT	5507003010031S	1	
	24	nsp	LABEL BOX KOLIN	AVR1508EUT	5507030000560S	1	
⚠	25	00D9630353403	CORD ASS'Y	AVC1508JP	L068125120030S	1	
	26	nsp	CARD GUARRANY	AVC1508JP	5777001470075S	1	
	★	nsp	SERIAL NO. LABEL		5507002000070S	1	
	★	nsp	LABEL LICENSE	E3 model	5507030000520S	1	
	★	nsp	LABEL LICENSE	E2 / EUT / JP model	5507030000311S	1	

--MEMO--

WIRING DIAGRAM

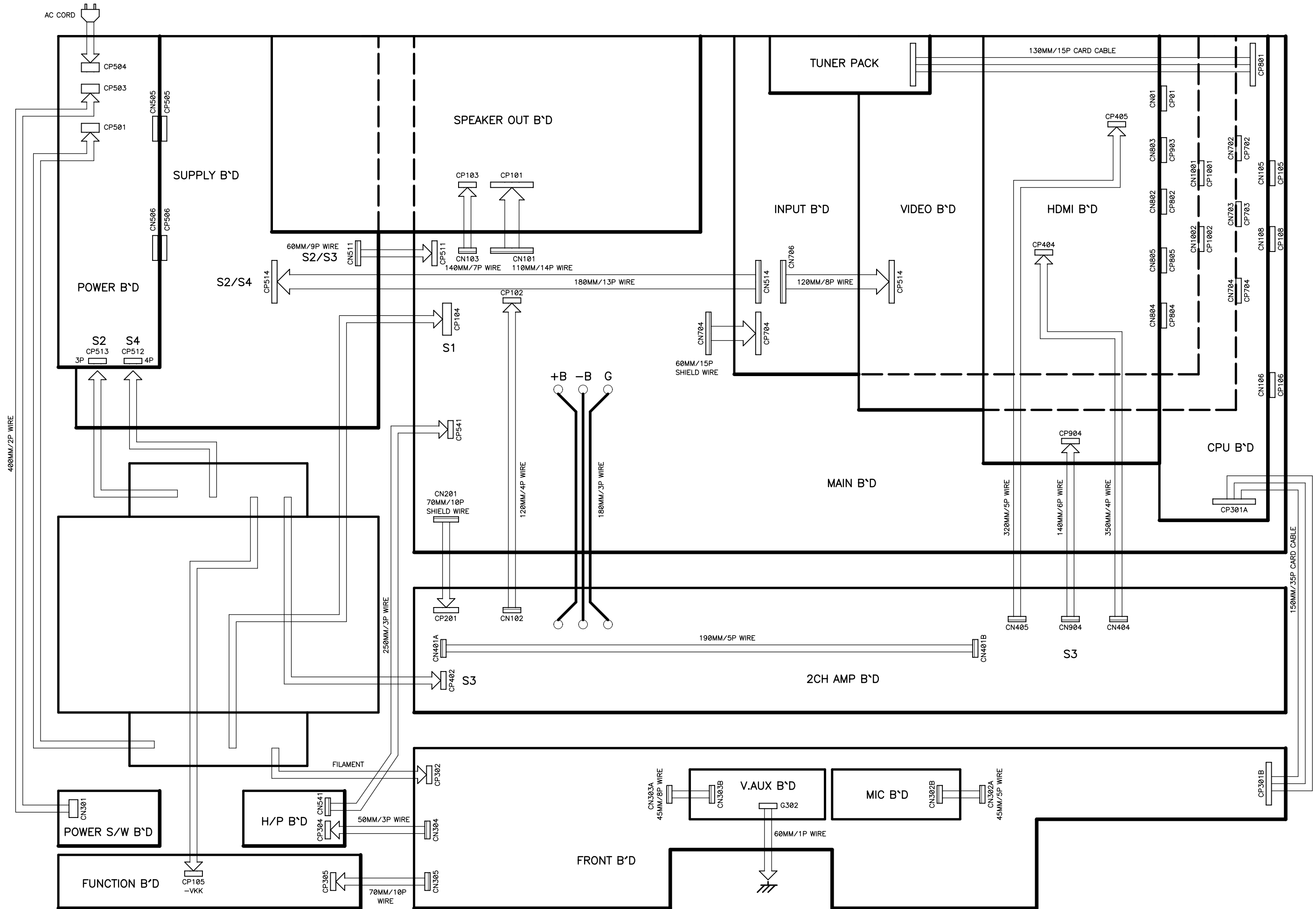

--MEMO--

NOTE FOR SCHEMATIC DIAGRAM

WARNING:

Parts marked with this symbol \triangle have critical characteristics. Use ONLY replacement parts recommended by the manufacturer.

CAUTION:

Before returning the unit to the customer, make sure you make either (1) a leakage current check or (2) a line to chassis resistance check. If the leakage current exceeds 0.5 milliamps, or if the resistance from chassis to either side of the power cord is less than 460 kohms, the unit is defective.

WARNING:

DO NOT return the unit to the customer until the problem is located and corrected.

NOTICE:

ALL RESISTANCE VALUES IN OHM. k=1,000 OHM
M=1,000,000 OHM
ALL CAPACITANCE VALUES IN MICRO FARAD.
P=MICRO-MICRO FARAD
EACH VOLTAGE AND CURRENT ARE MEASURED AT
NO SIGNAL INPUT CONDITION.
CIRCUIT AND PARTS ARE SUBJECT TO CHANGE
WITHOUT PRIOR NOTICE.

配線図について

\triangle 印の部品は安全を維持するために重要な部品です。従って交換時は必ず指定の部品を使用してください。

注)

- (1) 指定なき抵抗値は Ω 、k は k Ω 、M は M Ω を示す。
- (2) 指定なきコンデンサーの値は μF 、p は pF を示す。
- (3) 各部の電圧は無信号の値を示す。

この配線図は基本配線図です。改良等のため変更することがありますのでご了承ください。

--MEMO--

CAUTION: For continued safety, replace critical components only with manufacturers recommended parts (refer to parts list)

⚠ indicates safety critical components.

To reduce the risk of electric shock, leakage current or resistance measurements shall be carried out (exposed parts are acceptably insulated from the supply circuit) before the appliance returned to the customer.

MAIN (1/2)

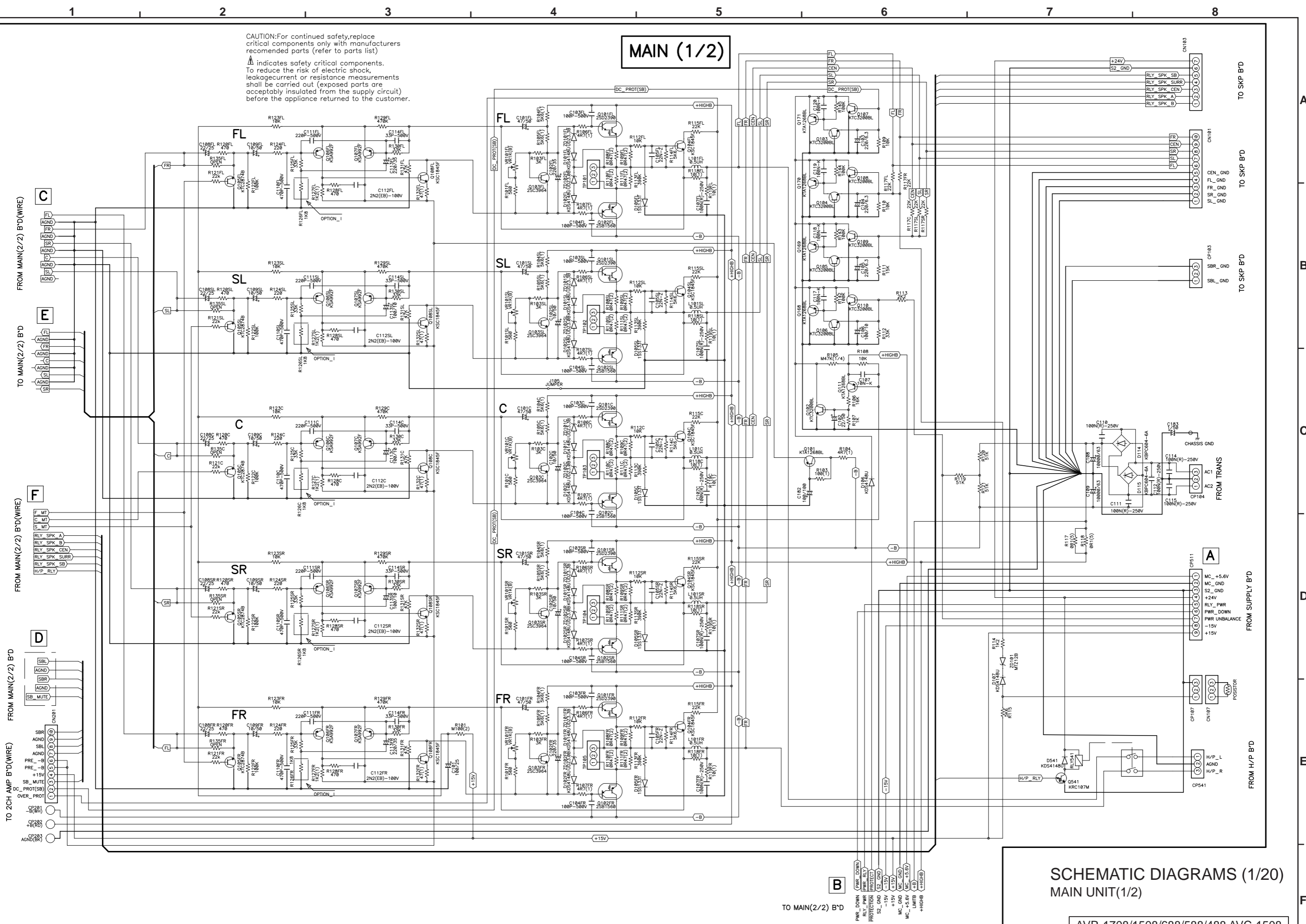

SCHMATIC DIAGRAMS (1/20)
MAIN UNIT(1/2)

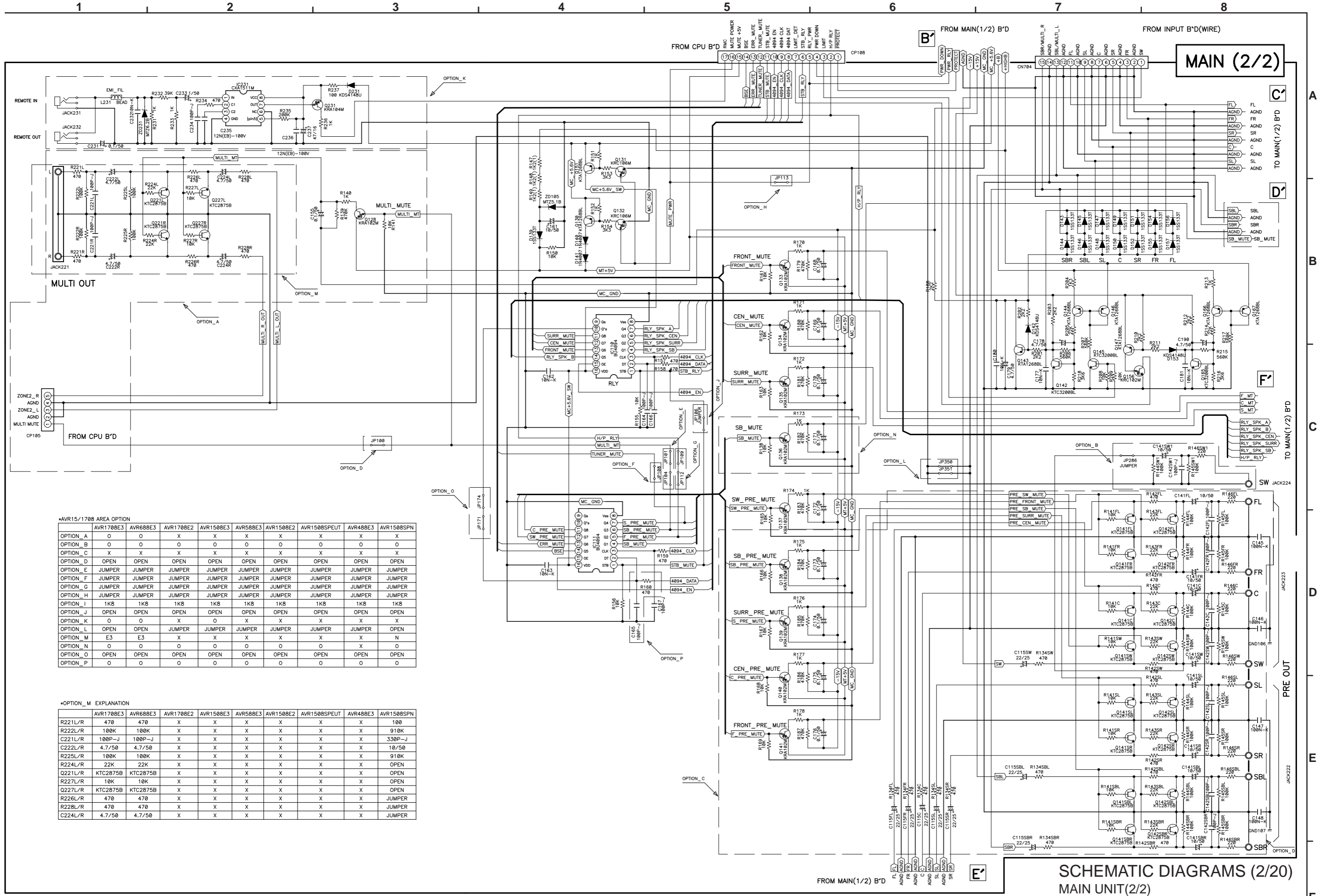

*AVR15/1708 AREA OPTION

	AVR1708E3	AVR688E3	AVR1708E2	AVR1508E3	AVR588E3	AVR1508E2	AVR1508SPEUT	AVR488E3	AVR1508SPN
OPTION_A	0	0	X	X	X	X	X	X	X
OPTION_B	0	0	0	0	0	0	0	0	0
OPTION_C	X	X	X	X	X	X	X	X	X
OPTION_D	OPEN	OPEN	OPEN	OPEN	OPEN	OPEN	OPEN	OPEN	OPEN
OPTION_E	JUMPER	JUMPER	JUMPER	JUMPER	JUMPER	JUMPER	JUMPER	JUMPER	JUMPER
OPTION_F	JUMPER	JUMPER	JUMPER	JUMPER	JUMPER	JUMPER	JUMPER	JUMPER	JUMPER
OPTION_G	JUMPER	JUMPER	JUMPER	JUMPER	JUMPER	JUMPER	JUMPER	JUMPER	JUMPER
OPTION_H	JUMPER	JUMPER	JUMPER	JUMPER	JUMPER	JUMPER	JUMPER	JUMPER	JUMPER
OPTION_I	1K8	1K8	1K8	1K8	1K8	1K8	1K8	1K8	1K8
OPTION_J	OPEN	OPEN	OPEN	OPEN	OPEN	OPEN	OPEN	OPEN	OPEN
OPTION_K	0	0	X	0	X	X	X	X	X
OPTION_L	OPEN	OPEN	JUMPER	JUMPER	JUMPER	JUMPER	JUMPER	JUMPER	OPEN
OPTION_M	E3	E3	X	X	X	X	X	X	N
OPTION_N	0	0	0	0	0	0	0	0	0
OPTION_O	OPEN	OPEN	OPEN	OPEN	OPEN	OPEN	OPEN	OPEN	OPEN
OPTION_P	0	0	0	0	0	0	0	0	0

*OPTION_M EXPLANATION

	AVR1708E3	AVR688E3	AVR1708E2	AVR1508E3	AVR588E3	AVR1508E2	AVR1508SPEUT	AVR488E3	AVR1508SPN
R221L/R	470	470	X	X	X	X	X	X	100
R222L/R	100K	100K	X	X	X	X	X	X	910K
C221L/R	100P-J	100P-J	X	X	X	X	X	X	330P-J
R222L/R	4.7/50	4.7/50	X	X	X	X	X	X	10/50
R225L/R	100K	100K	X	X	X	X	X	X	910K
R224L/R	22K	22K	X	X	X	X	X	X	OPEN
Q221L/R	KTC2875B	KTC2875B	X	X	X	X	X	X	OPEN
R227L/R	10K	10K	X	X	X	X	X	X	OPEN
Q227L/R	KTC2875B	KTC2875B	X	X	X	X	X	X	OPEN
R226L/R	470	470	X	X	X	X	X	X	JUMPER
R228L/R	470	470	X	X	X	X	X	X	JUMPER
R224L/R	4.7/50	4.7/50	X	X	X	X	X	X	JUMPER

SCHEMATIC DIAGRAMS (2/20)
MAIN UNIT(2/2)

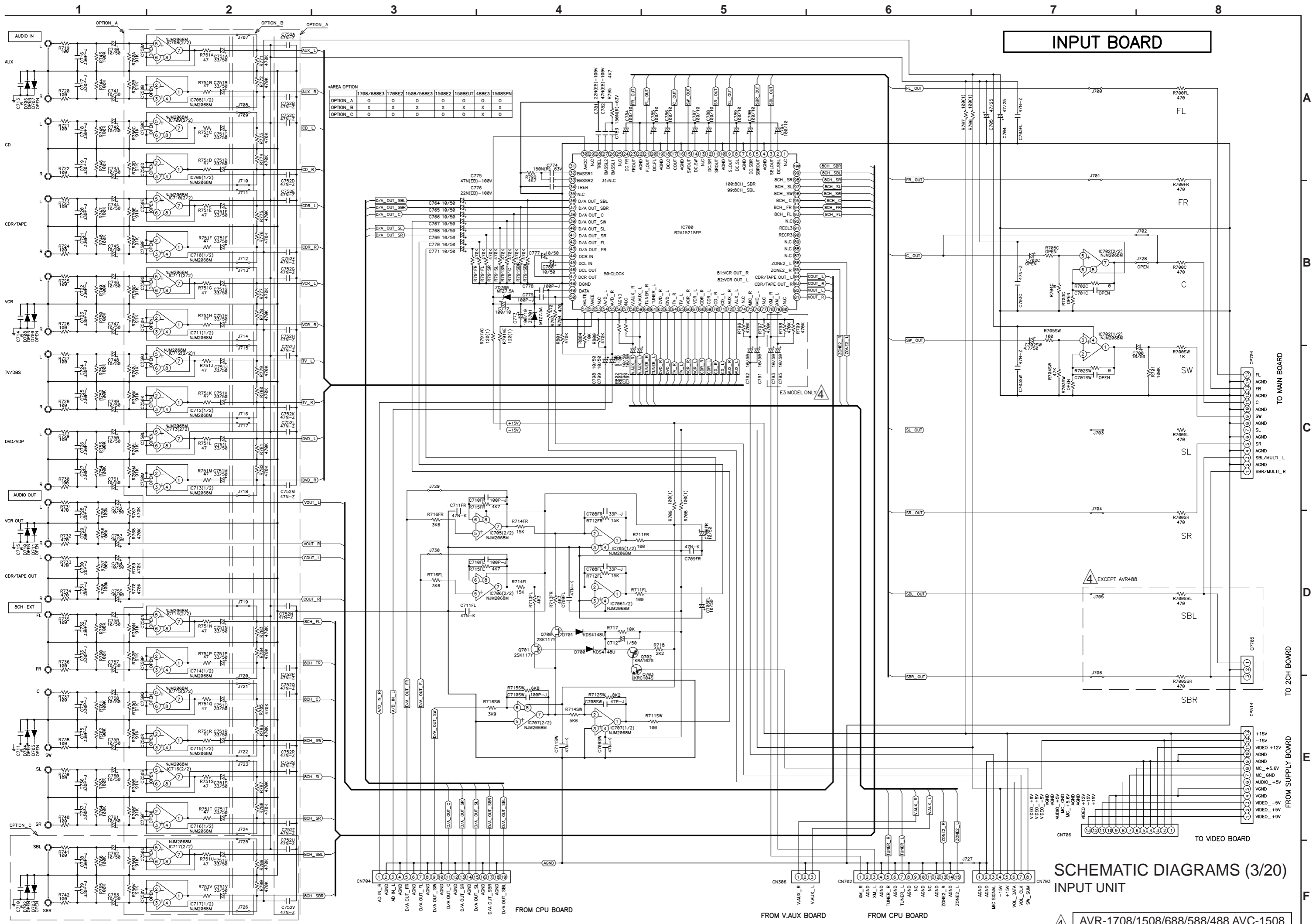

AREA OPTION

	1708/688E3	1708E2	1508/588E3	1508E2	1508EUT	488E3	1508SPN
OPTION_A	O	O	O	O	O	O	O
OPTION_B	X	X	X	X	X	X	X
OPTION_C	O	O	O	O	O	X	O

INPUT BOARD

SCHEMATIC DIAGRAMS (3/20) INPUT UNIT

AVR-1708/1508/688/588/488 AVC-1508

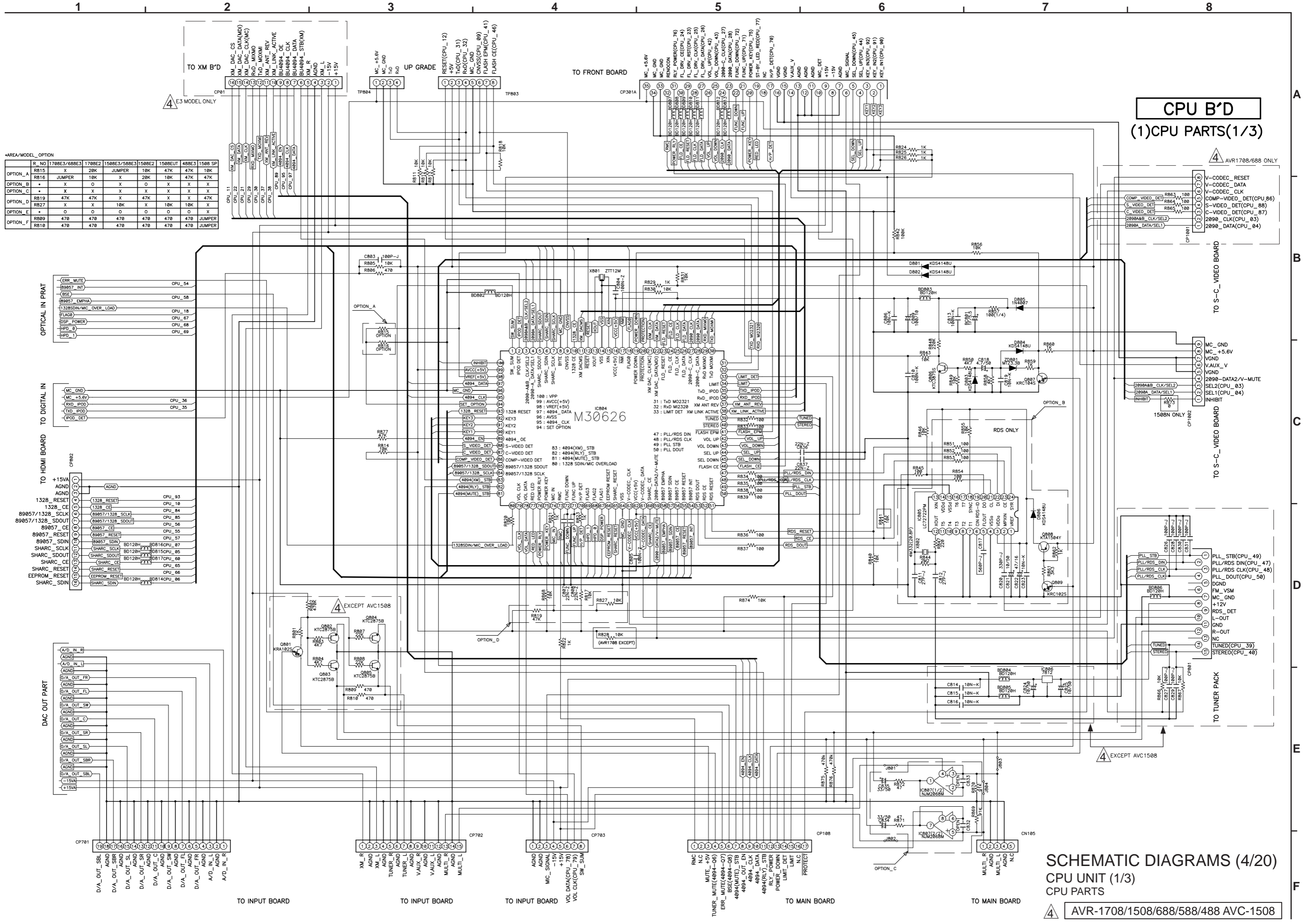

AREA/MODEL_OPTION

OPTION_A	R	NO	1708E3/688E3	1708E2	1508E3/588E3	1508E2	1508E1	488E3	1508 SP
R815	X	JUMPER	X	X	X	X	X	X	X
R816	X	JUMPER	X	X	X	X	X	X	X
OPTION_B	*	X	0	X	0	X	X	X	X
OPTION_C	*	X	X	X	X	X	X	X	X
OPTION_D	R819	47K	47K	X	47K	X	X	47K	X
OPTION_E	R827	X	X	10K	X	10K	10K	X	X
OPTION_F	R809	470	470	470	470	470	470	JUMPER	X
OPTION_G	R810	470	470	470	470	470	470	JUMPER	X

CPU B'D
(1) CPU PARTS (1/3)

CPU B'D
(2)OPTICAL IN PARTS(2/3)

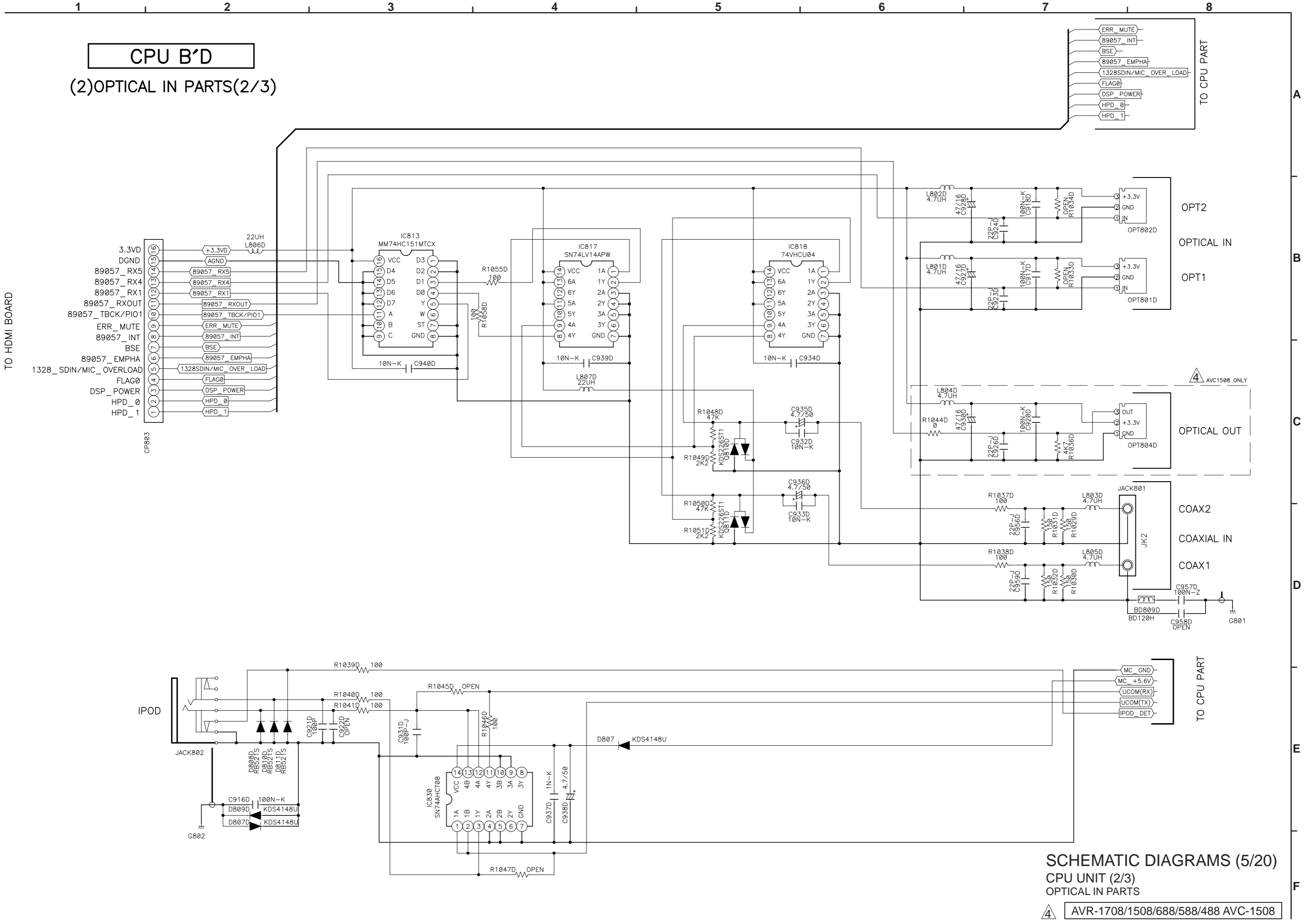

SCHEMATIC DIAGRAMS (5/20)
CPU UNIT (2/3)
OPTICAL IN PARTS
 AVR-1708/1508/688/588/488 AVC-1508

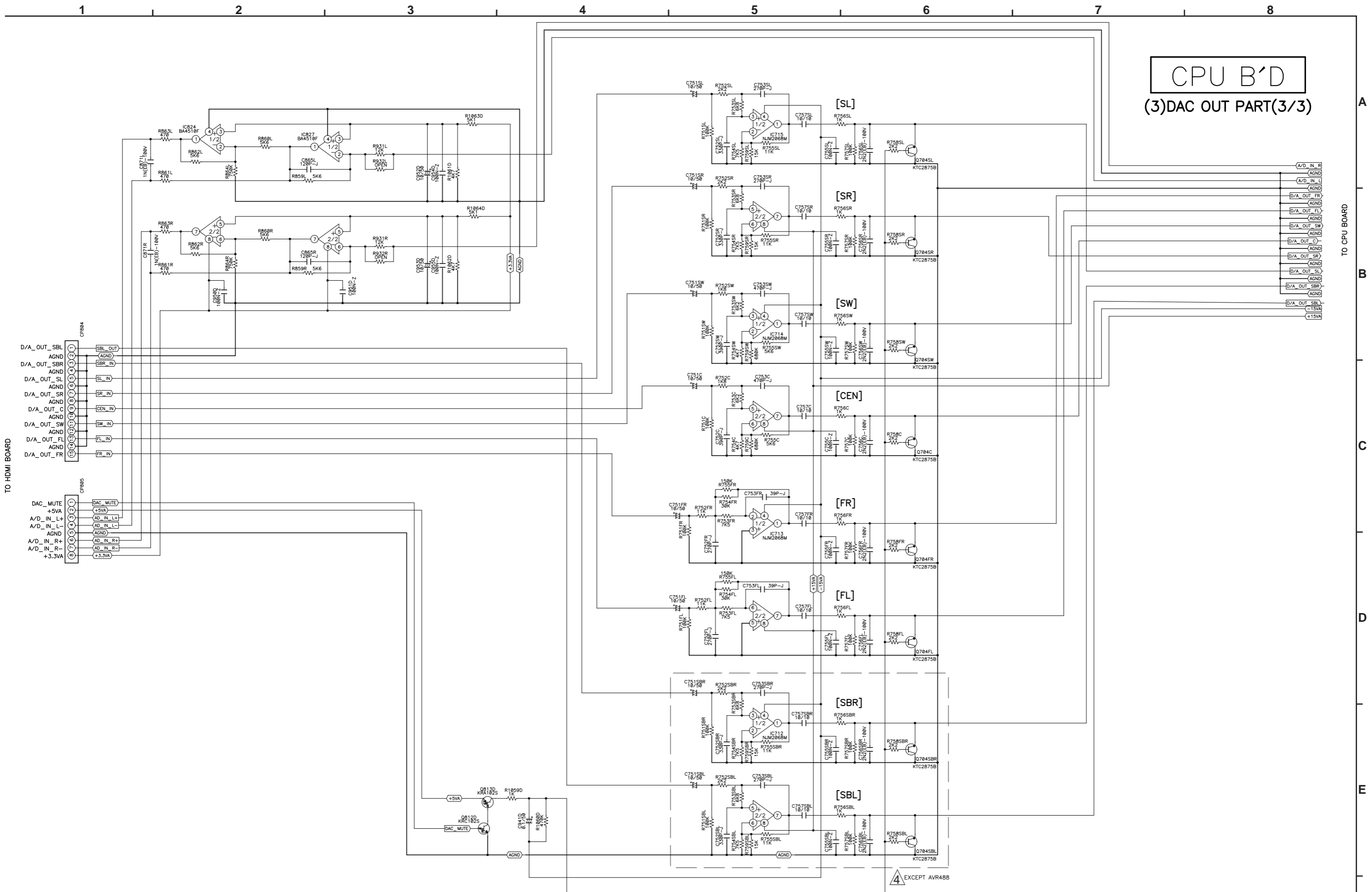

CPU B'D
(3)DAC OUT PART(3/3)

SCHEMATIC DIAGRAMS (6/20)
CPU UNIT (3/3)
DAC OUT PARTS

AVR-1708/1508/688/588/488 AVC-1508

EXCEPT AVR488

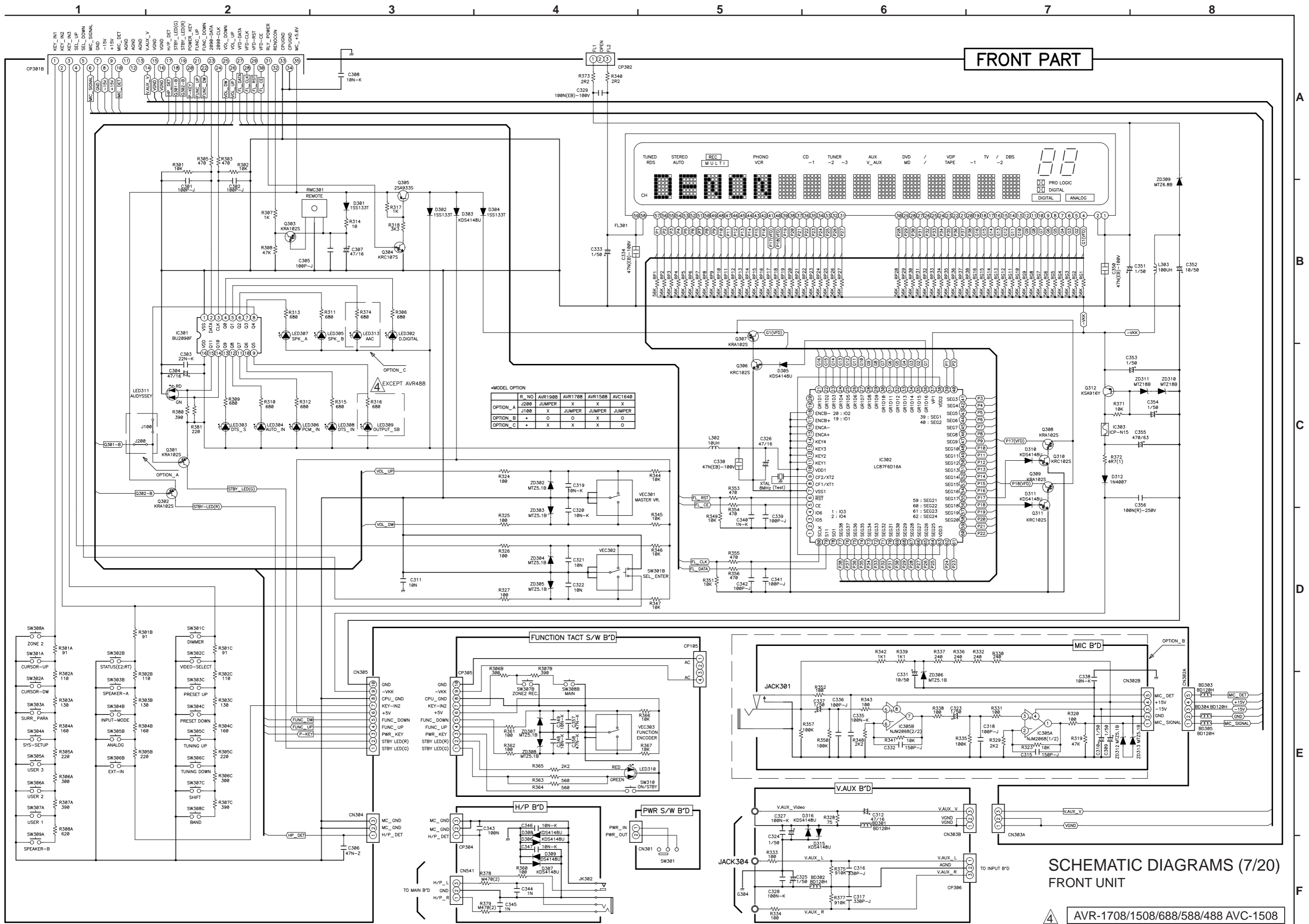

FRONT PART

***MODEL OPTION**

R_NO	AVR1908	AVR1708	AVR1508	AVC1648
OPTION_A	J200	X	X	X
OPTION_B	J100	X	X	X
OPTION_C	*	X	X	O

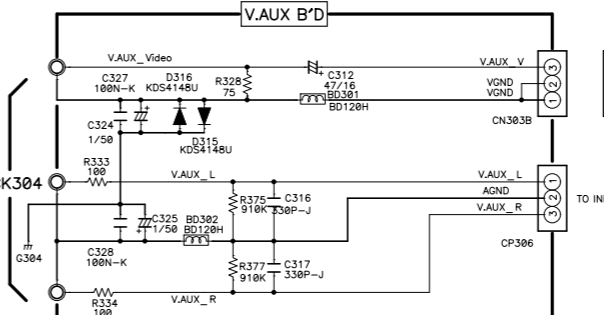
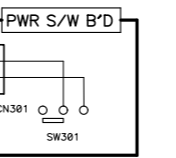
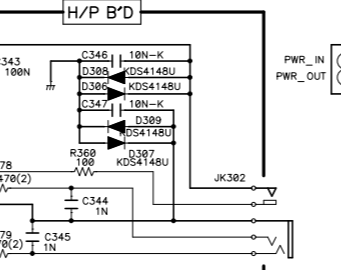
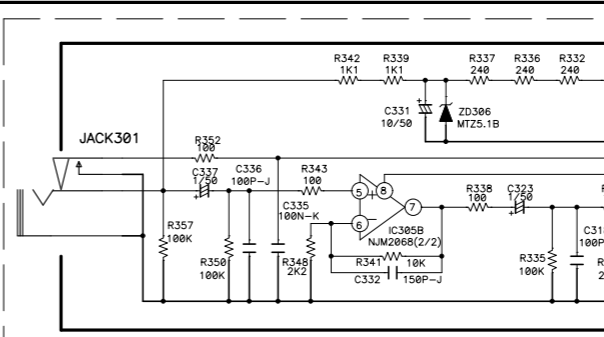
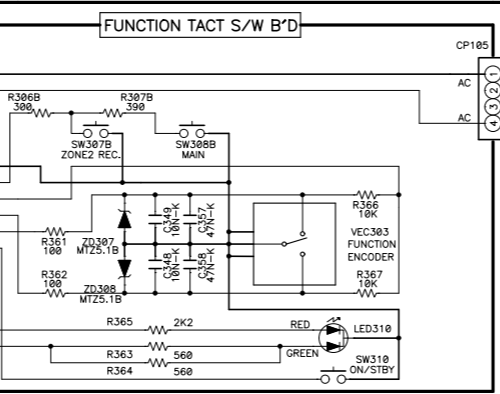

**SCHEMATIC DIAGRAMS (7/20)
FRONT UNIT**

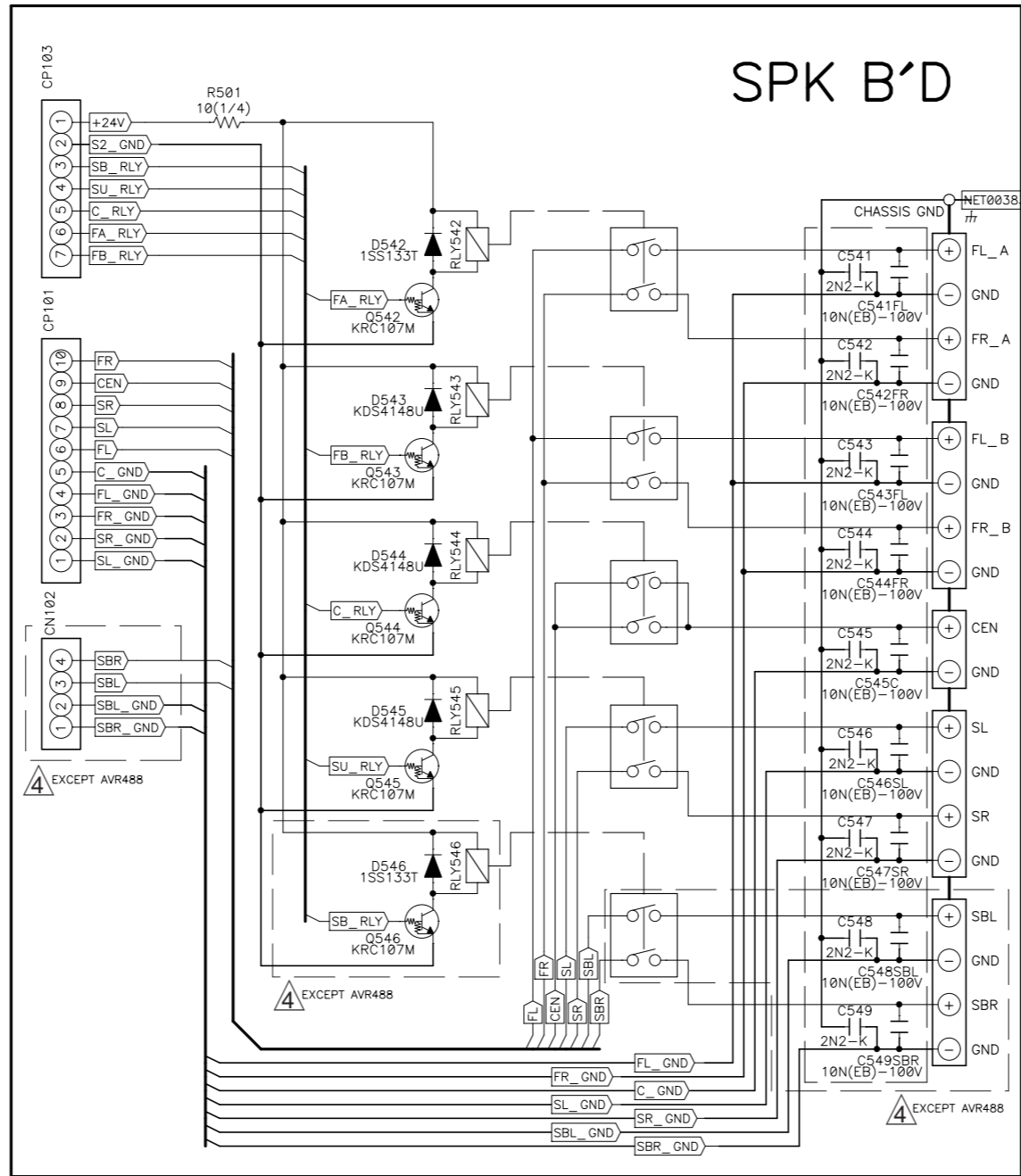

SCHMATIC DIAGRAMS (8/20)
SPK UNIT

HDMI B'D

(1)HDMI I/O SWITCHER PARTS(1/4)

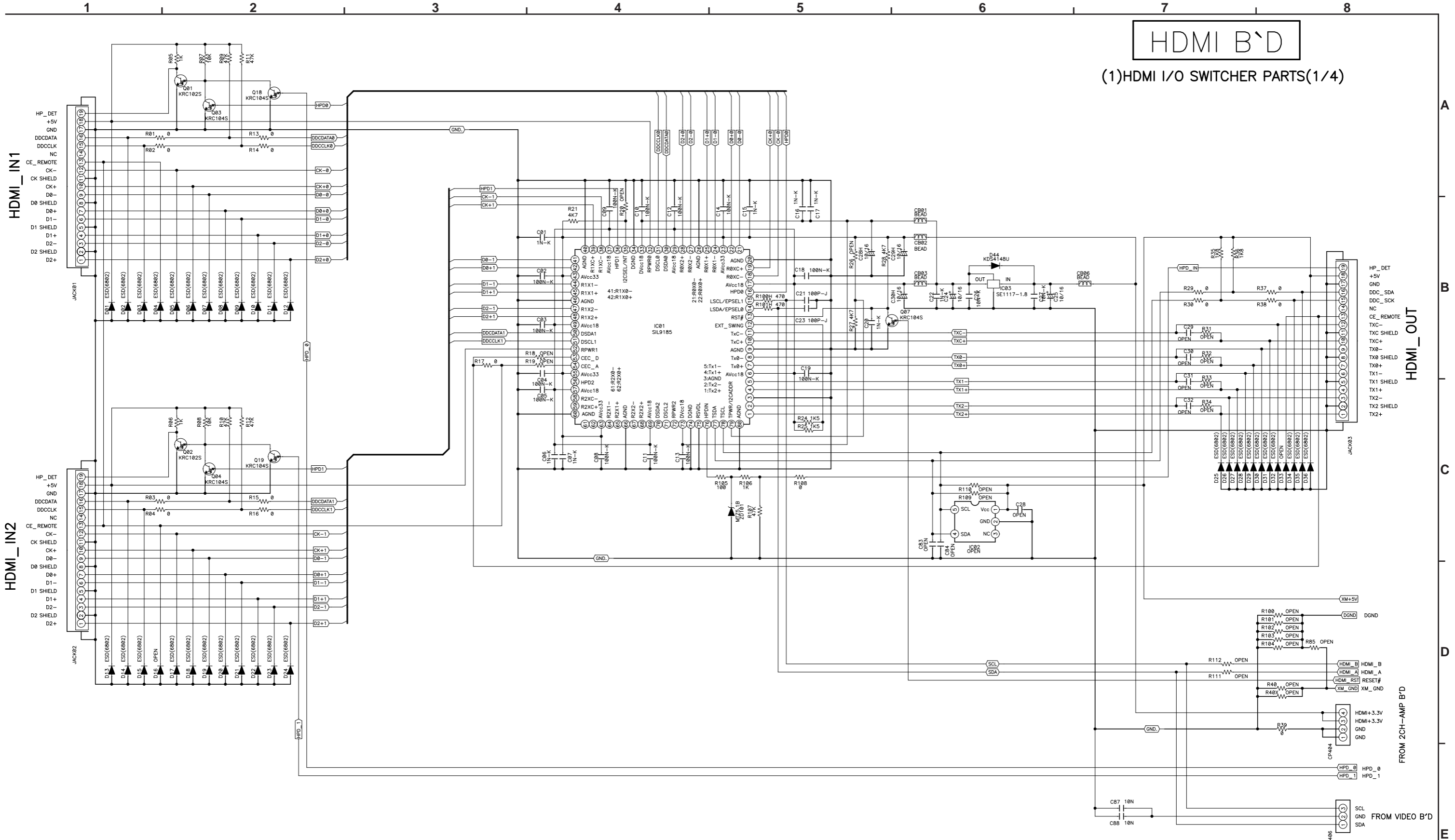

SCHEMATIC DIAGRAMS (9/20)
HDMI UNIT (1/4)
HDMI I/O SWITCHER PARTS

AVR-1708/1508/688/588/488 AVC-1508

HDMI B'D

(2)XM PARTS(E3/688/588/488_ONLY_(2/4)

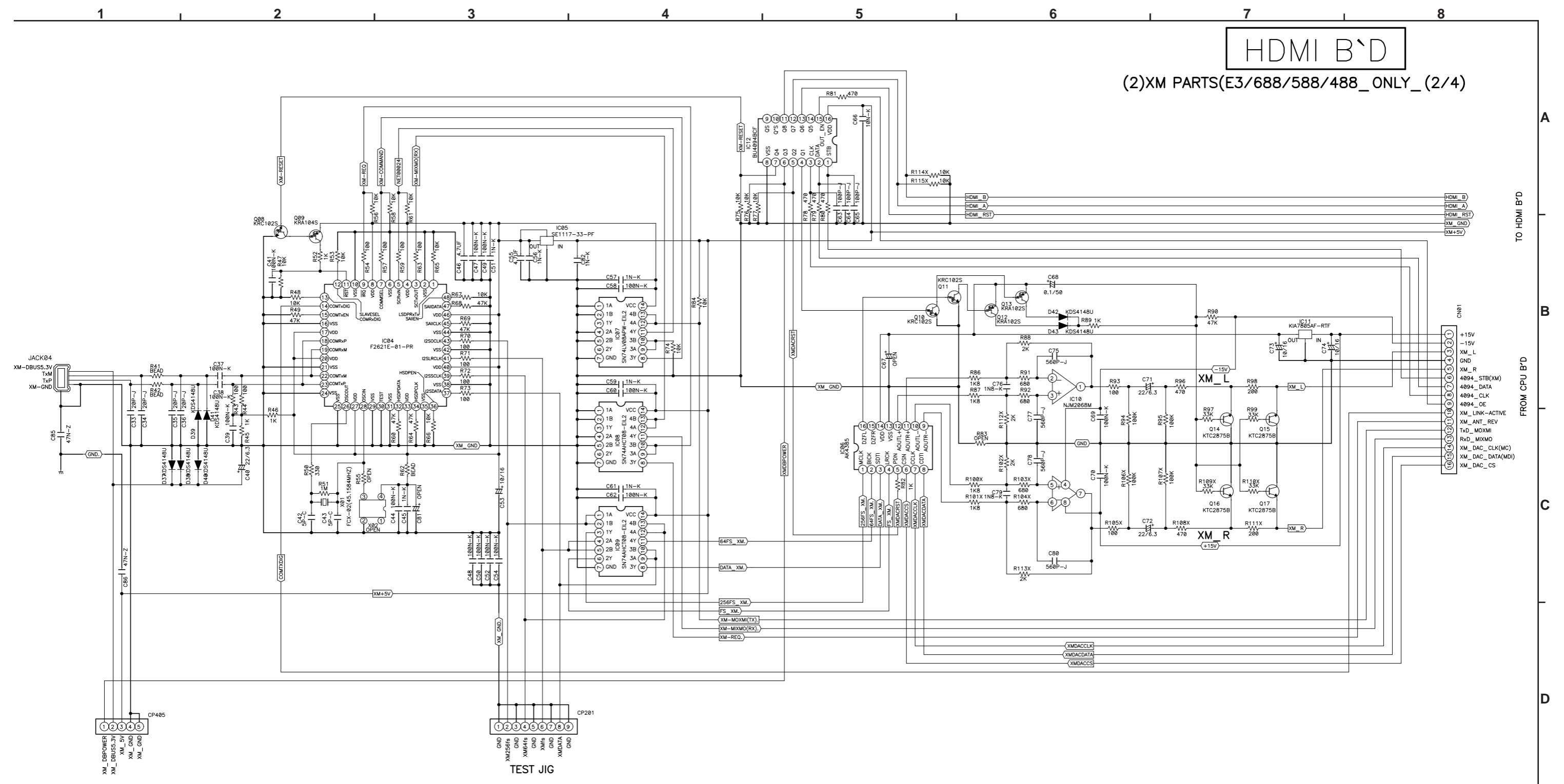

FROM 2CH-AMP B'D

TEST JIG

TO HDMI B'D

FROM CPU B'D

SCHEMATIC DIAGRAMS (10/20)
HDMI UNIT (2/4)
XM PARTS
(AVR-1708/1508/688/588/488 E3 model only)

AVR-1708/1508/688/588/488 AVC-1508

HDMI B'D

(3)DSP/ROM/RAM PARTS(3/4)

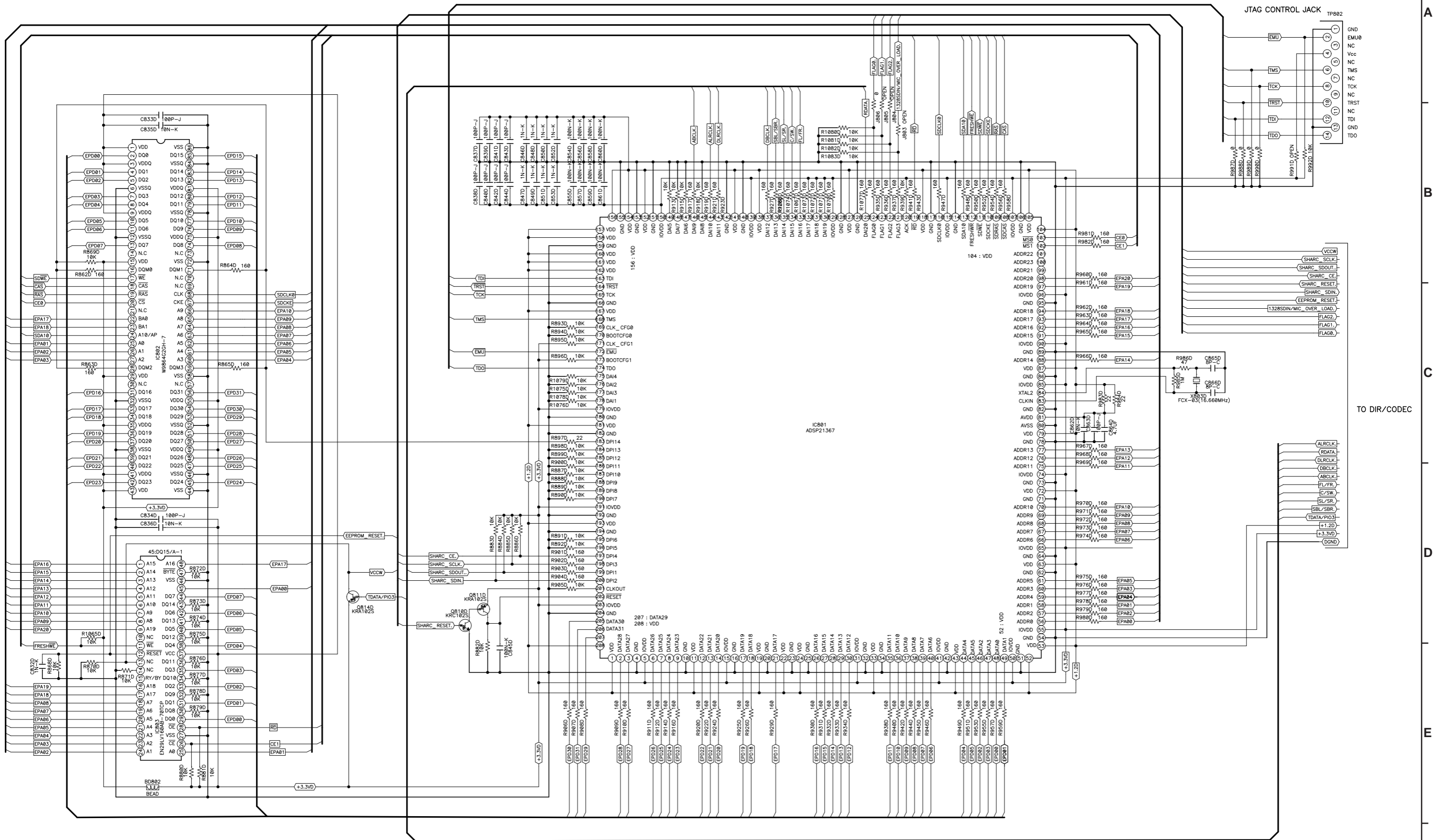

HDMI B'D

(4)DIR/CODEC PARTS(4/4)

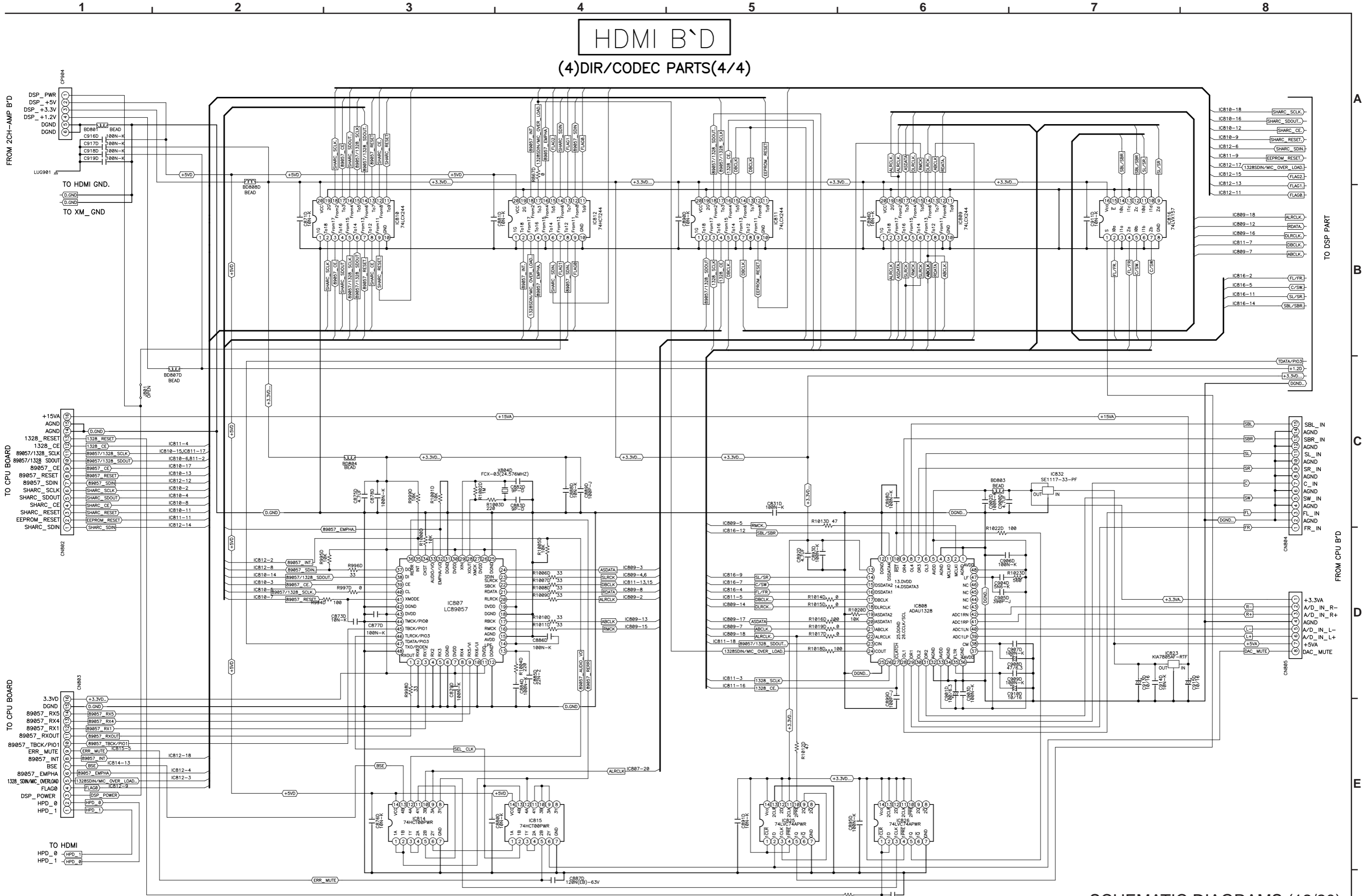

SCHEMATIC DIAGRAMS (12/20)
 HDMI UNIT (4/4)
 DIR/CODEC PARTS
 AVR-1708/1508/688/588/488 AVC-1508

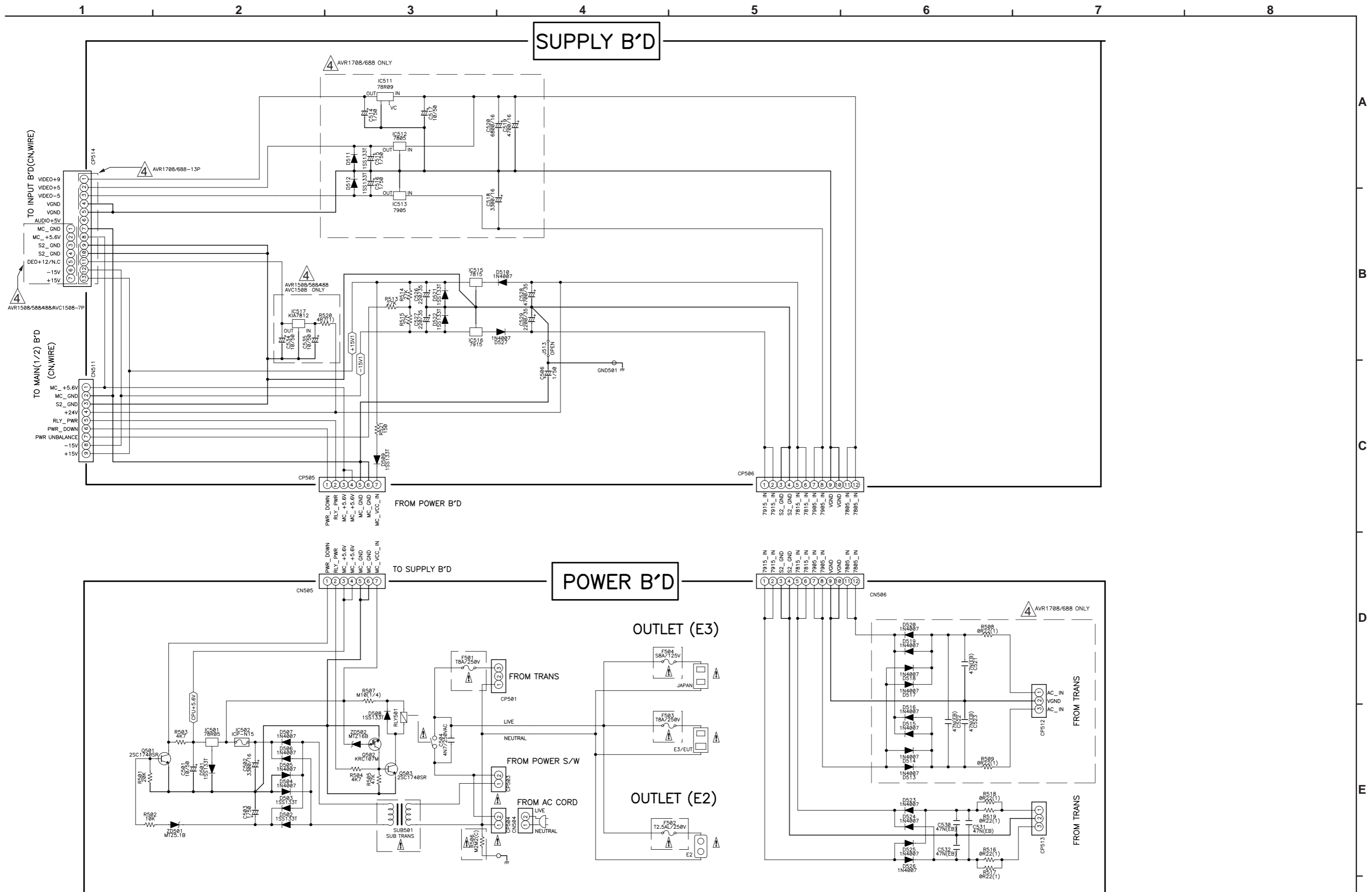

SCHMATIC DIAGRAMS (13/20)
 SUPPLY UNIT
 POWER UNIT
 AVR-1708/1508/688/588/488 AVC-1508

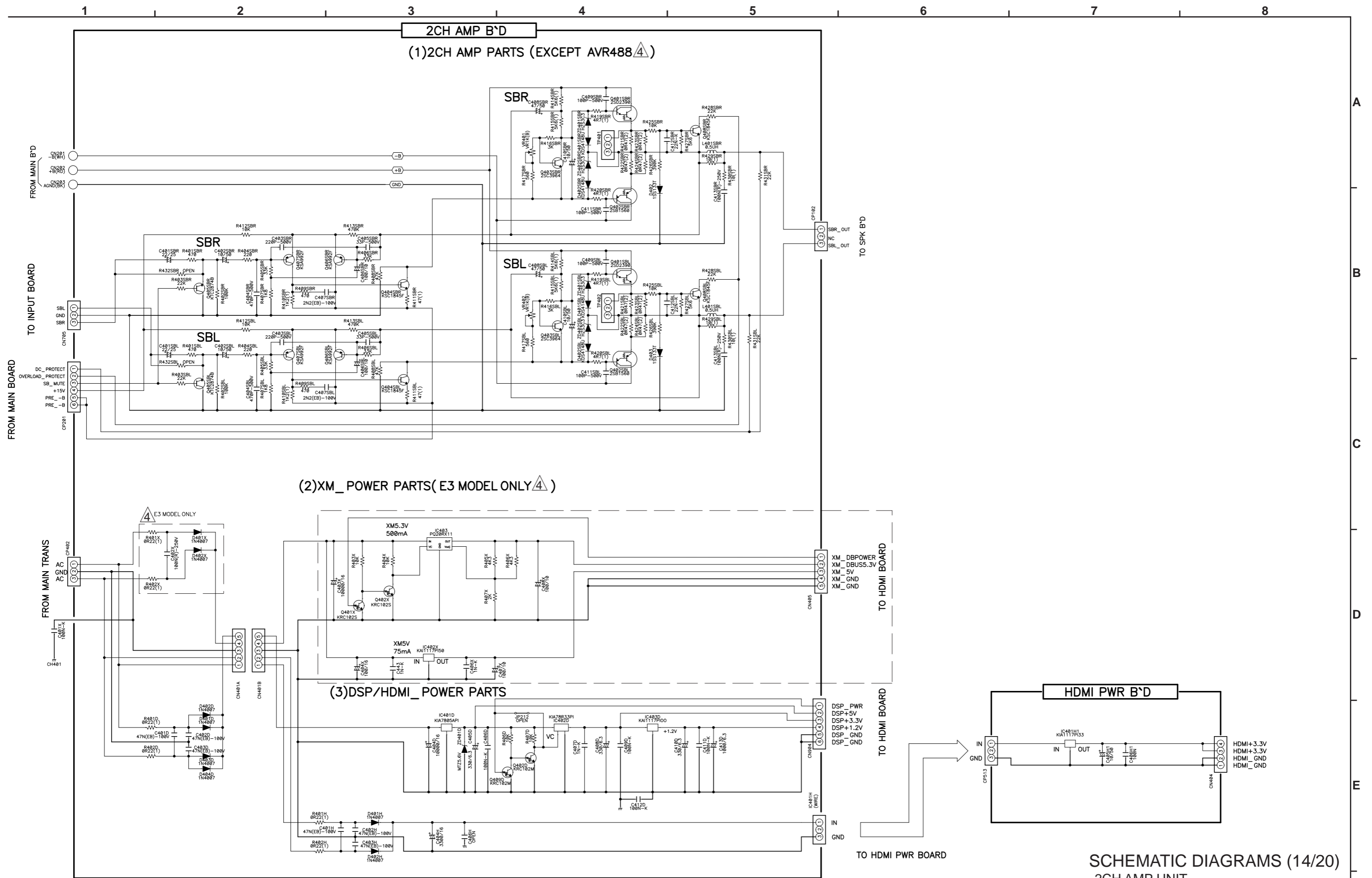

SCHEMATIC DIAGRAMS (14/20)
 2CH AMP UNIT
 2CH AMP PARTS
 XM_POWER PARTS
 (AVR-1708/1508/688/588/488 E3 model only)
 DSP/HDMI_POWER PARTS
 AVR-1708/1508/688/588/488 AVC-1508

VIDEO B'D

(1)C_VIDEO PARTS(AVR1708E3/E2/6880ONLY_(1/3))

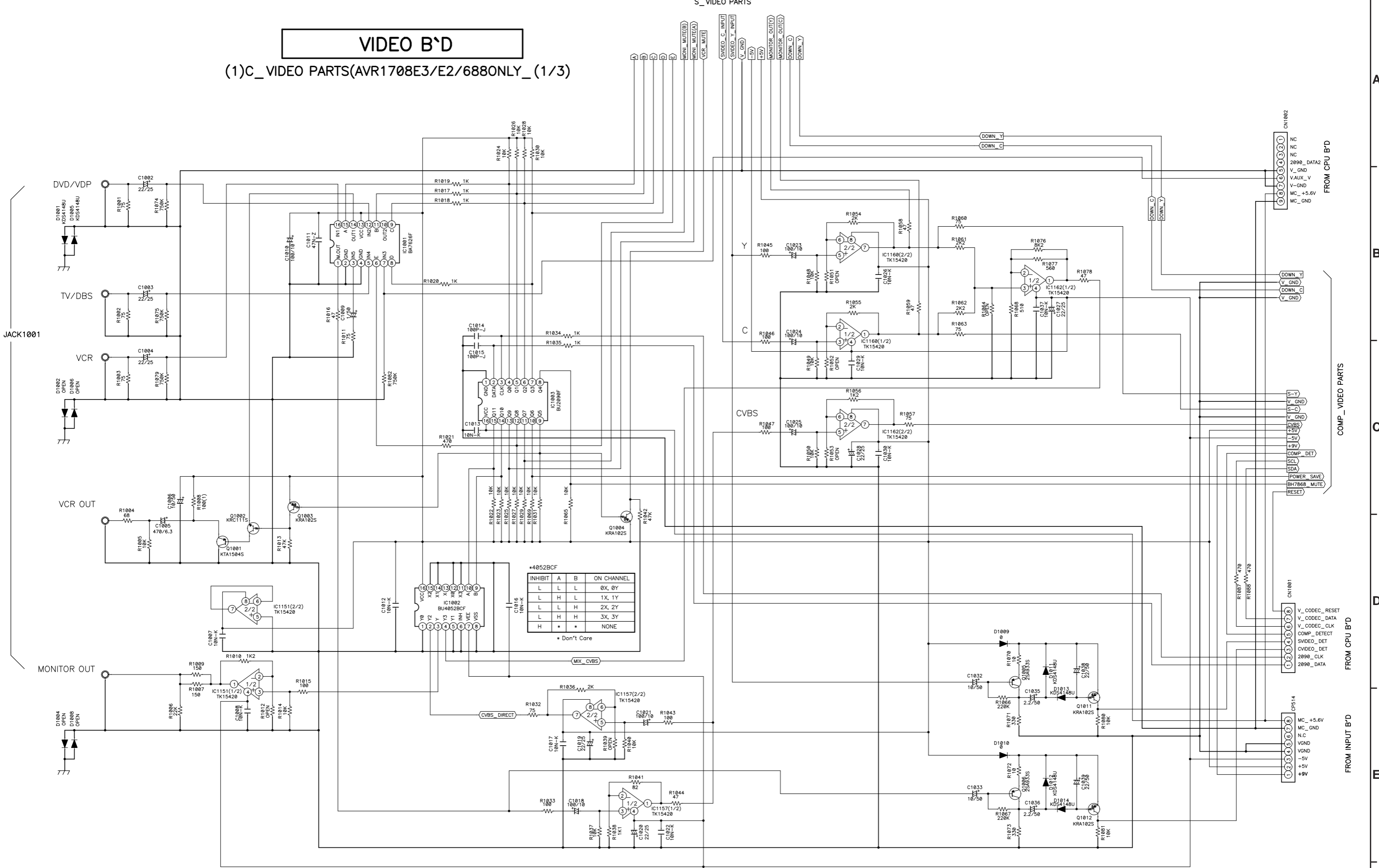

*4052BCF			
INHIBIT	A	B	ON CHANNEL
L	L	L	0X, 0Y
L	L	H	1X, 1Y
L	H	L	2X, 2Y
L	H	H	3X, 3Y
H	*	*	NONE
* Don't Care			

A	B	E	MONITOR_OUT	C	D	E	REC_OUT
L	L	*	IN1(VCR)	H	H	*	-
H	L	*	IN2(DVD)	H	L	*	IN2
L	H	*	IN3(V.AUX)	H	H	*	IN3
H	H	L	IN4(TV)	H	L	*	IN4
H	H	H	IN5(MUTE)	H	H	H	IN5

SCHEMATIC DIAGRAMS (15/20)
VIDEO UNIT (1/3)
C_VIDEO PARTS
 (AVR-1708E3/1708E2/688E3 model only)

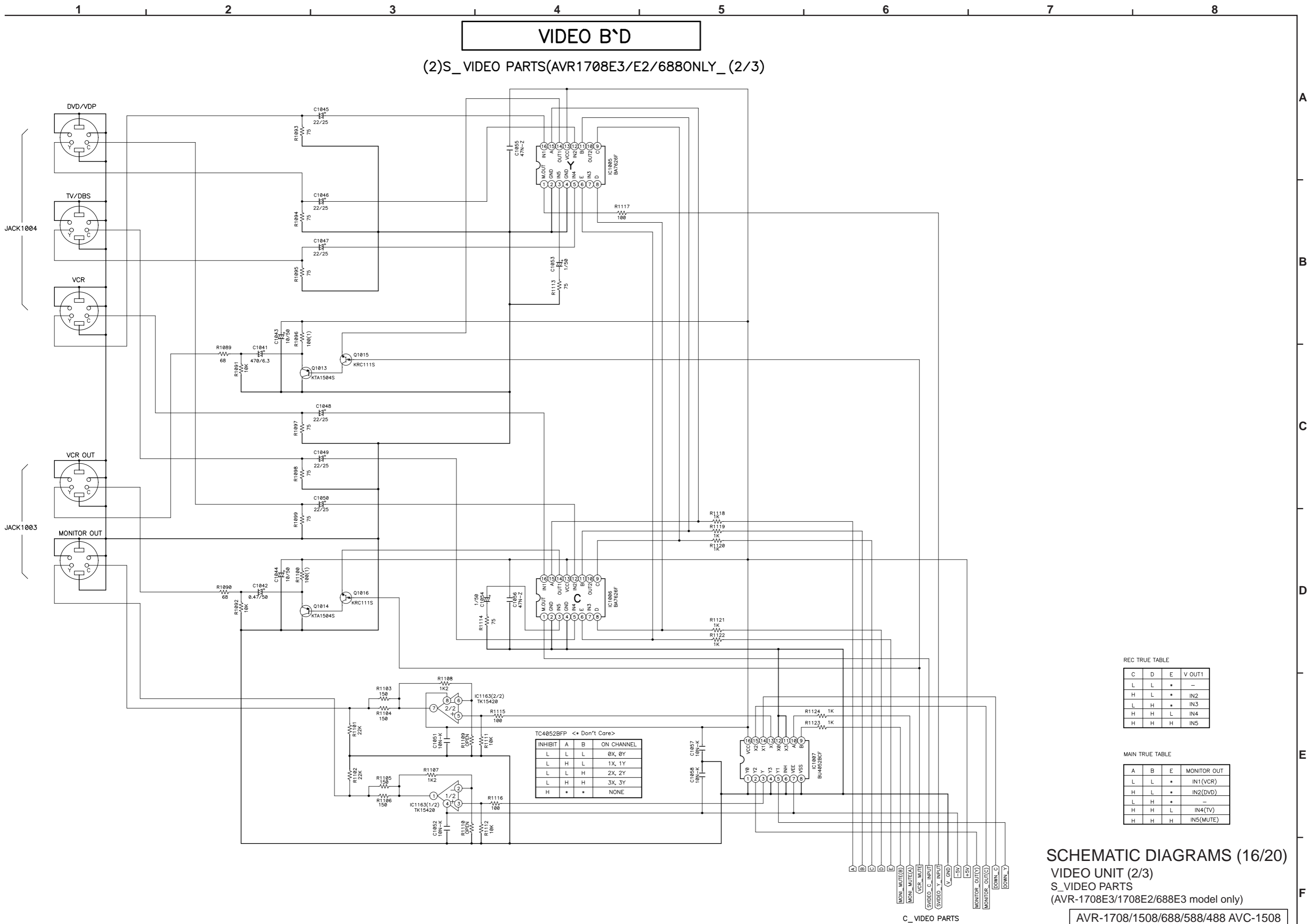

VIDEO B'D
 (2)S_VIDEO PARTS(AVR1708E3/E2/688ONLY_(2/3))

REC TRUE TABLE

C	D	E	V OUT1
L	L	*	-
H	L	*	IN2
L	H	*	IN3
H	H	L	IN4
H	H	H	IN5

MAIN TRUE TABLE

A	B	E	MONITOR OUT
L	L	*	IN1(VCR)
H	L	*	IN2(DVD)
L	H	*	-
H	H	L	IN4(TV)
H	H	H	IN5(MUTE)

TC4052BFP << Don't Care >>

INHIBIT	A	B	ON CHANNEL
L	L	L	0X, 0Y
L	H	L	1X, 1Y
L	L	H	2X, 2Y
L	H	H	3X, 3Y
H	*	*	NONE

SCHEMATIC DIAGRAMS (16/20)
 VIDEO UNIT (2/3)
 S_VIDEO PARTS
 (AVR-1708E3/1708E2/688E3 model only)

AVR-1708/1508/688/588/488 AVC-1508

C_VIDEO PARTS

VIDEO B'D

(3)COMP_VIDEO PARTS(AVR1708E3/E2/688ONLY_(3/3))

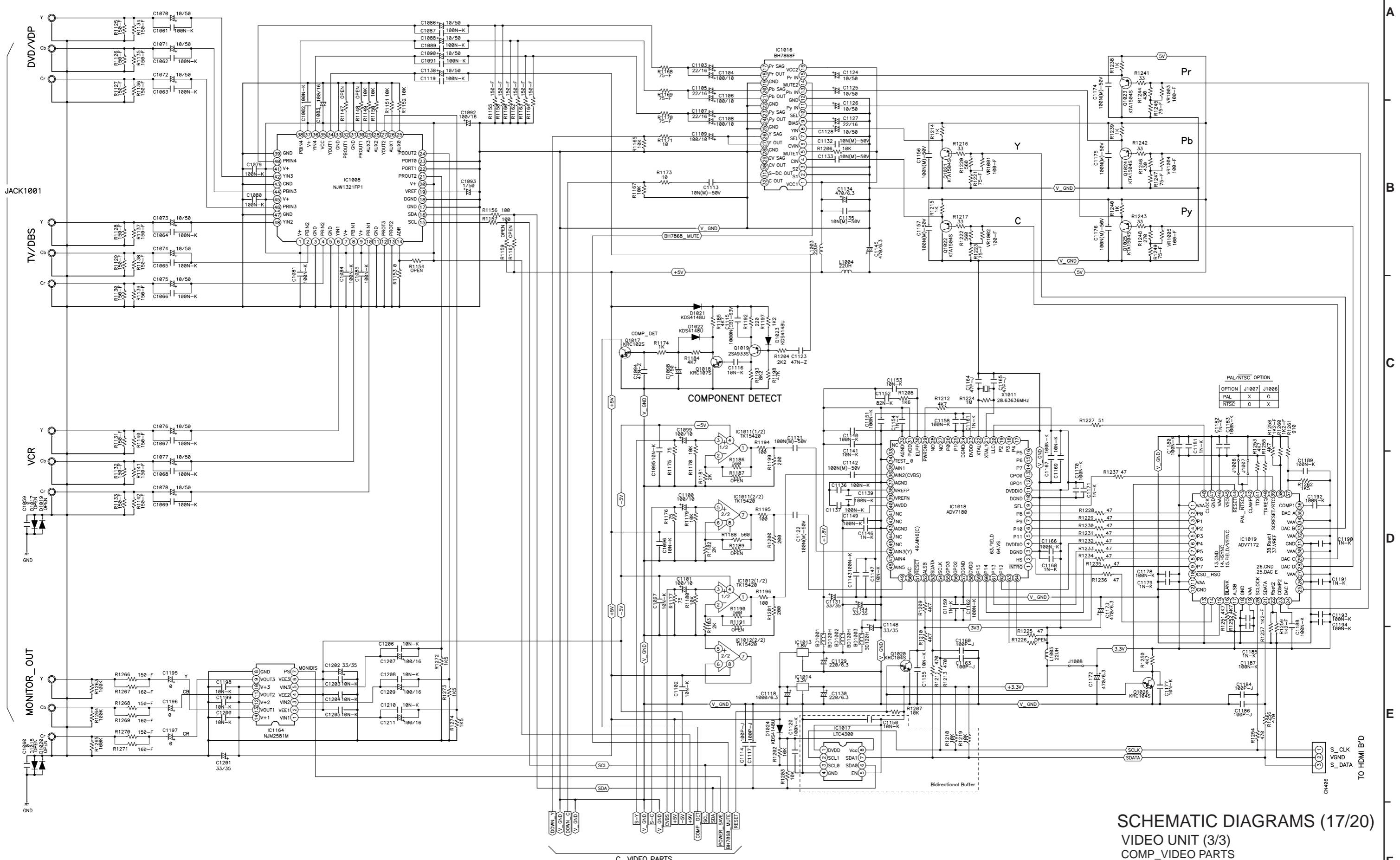

PAL/NTSC OPTION

OPTION	J1007	J1006
PAL	X	O
NTSC	O	X

SCHEMATIC DIAGRAMS (17/20)
 VIDEO UNIT (3/3)
 COMP_VIDEO PARTS
 (AVR-1708E3/1708E2/688E3 model only)

AVR-1708/1508/688/588/488 AVC-1508

C_VIDEO PARTS

TO HDMI B'D

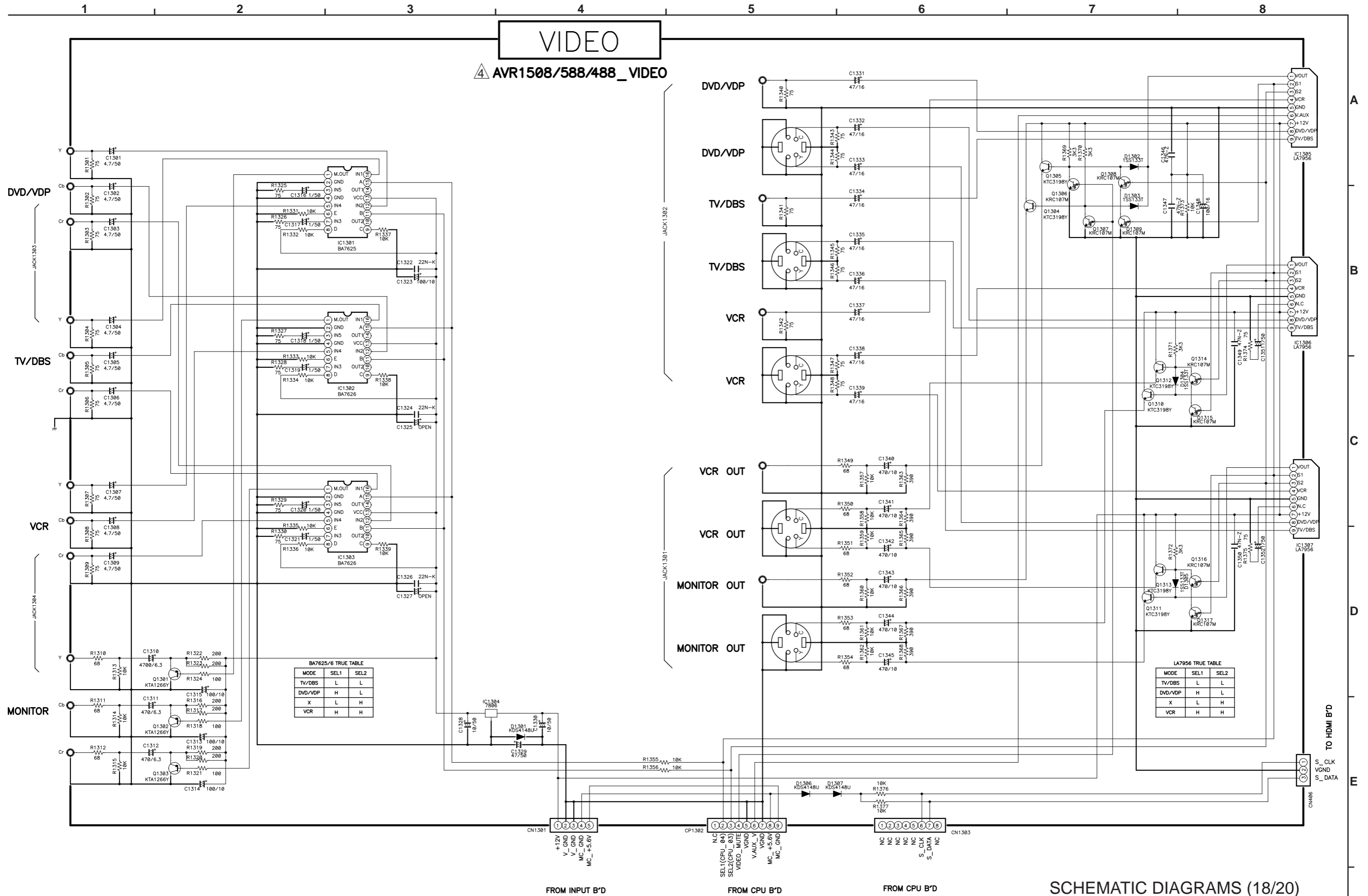

VIDEO
 4 AVR1508/588/488_VIDEO

BA7625/6 TRUE TABLE

MODE	SEL1	SEL2
TV/DBS	L	L
DVD/VDP	H	L
X	L	H
VCR	H	H

LA7956 TRUE TABLE

MODE	SEL1	SEL2
TV/DBS	L	L
DVD/VDP	H	L
X	L	H
VCR	H	H

SCHEMATIC DIAGRAMS (18/20)
VIDEO UNIT
 4 (AVR-1508E3/1508E2/1508EUT/588E3/488E3 model only)

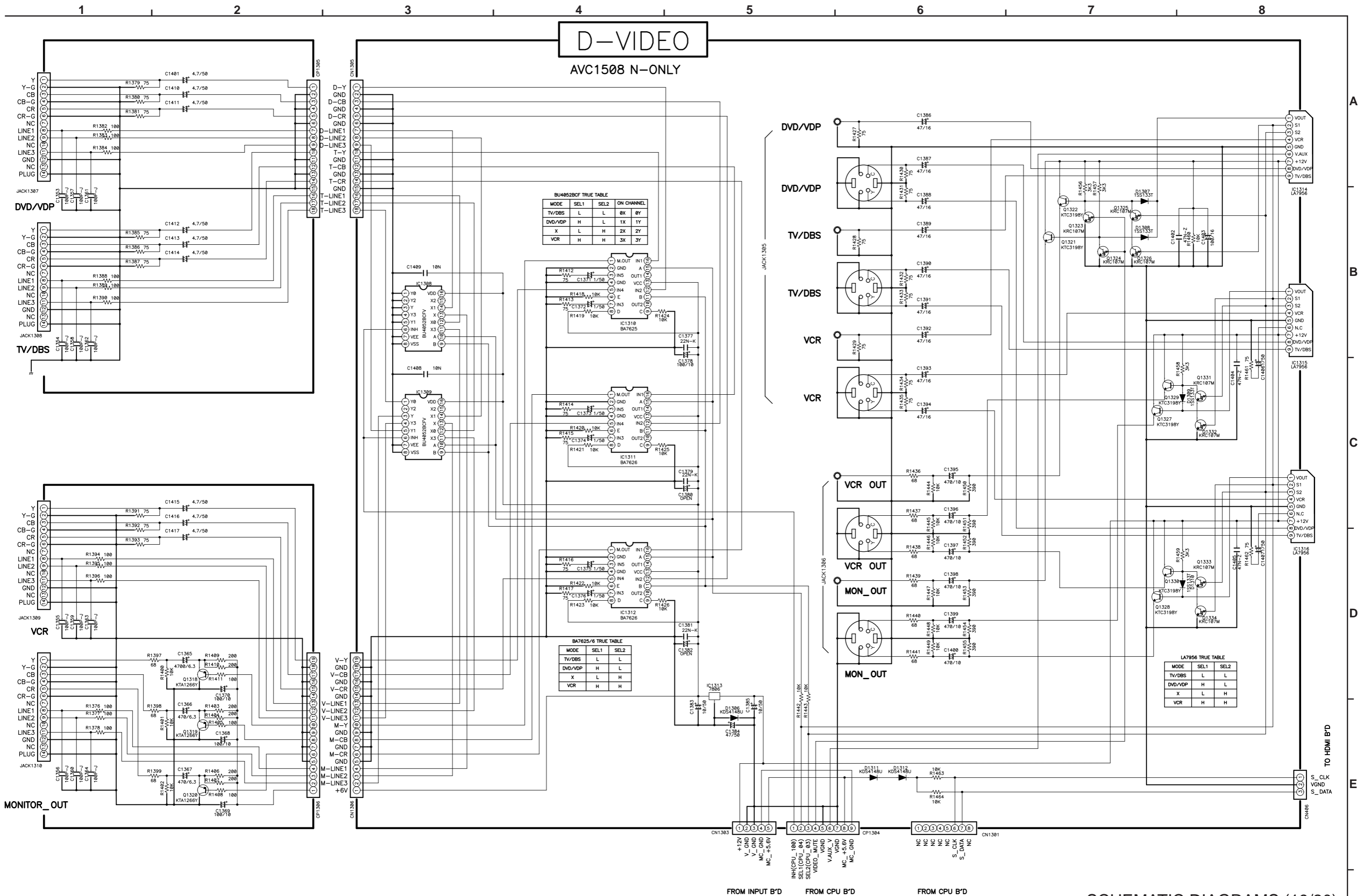

D-VIDEO

AVC1508 N-ONLY

BU4852BCF TRUE TABLE

MODE	SEL1	SEL2	ON CHANNEL
TV/DBS	L	L	0X 0Y
DVD/VDP	H	L	1X 1Y
X	L	H	2X 2Y
VCR	H	H	3X 3Y

BA7625/6 TRUE TABLE

MODE	SEL1	SEL2
TV/DBS	L	L
DVD/VDP	H	L
X	L	H
VCR	H	H

LA7956 TRUE TABLE

MODE	SEL1	SEL2
TV/DBS	L	L
DVD/VDP	H	L
X	L	H
VCR	H	H

SCHEMATIC DIAGRAMS (19/20)
D-VIDEO UNIT
 (AVC-1508 Japan model only)

AVR-1708/1508/688/588/488 AVC-1508

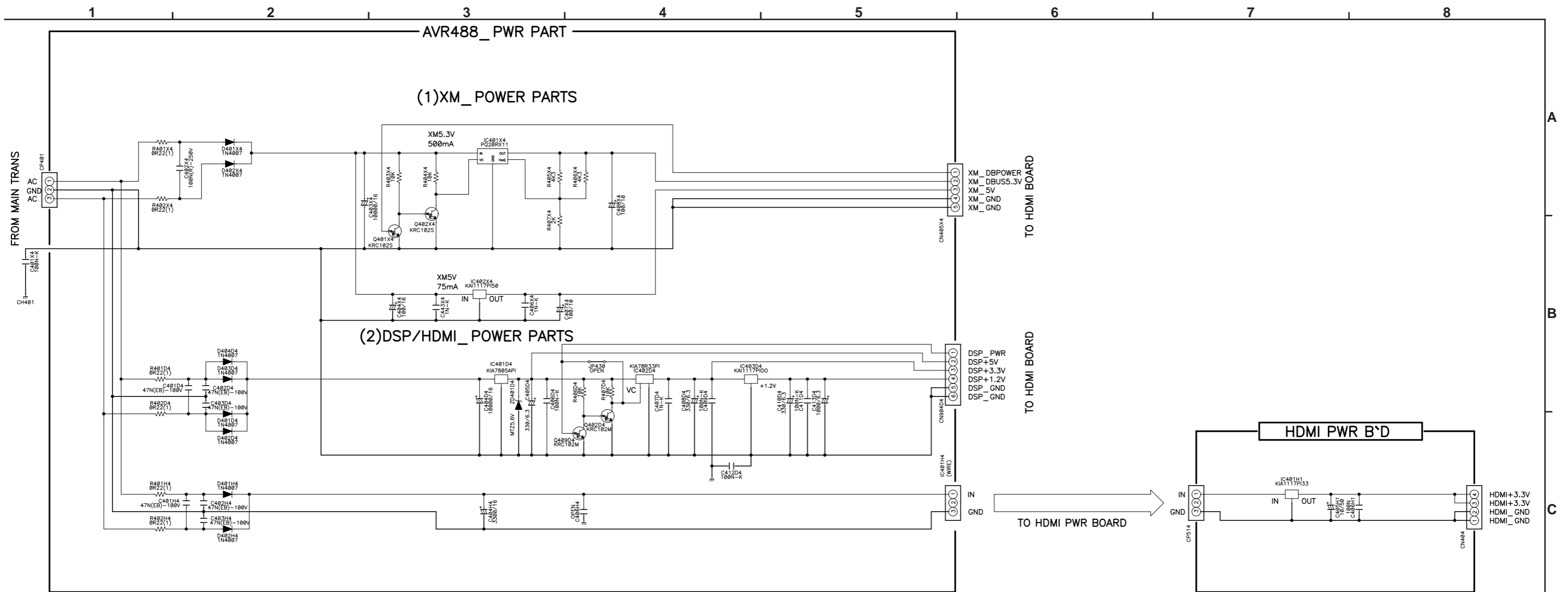

SCHEMATIC DIAGRAMS (20/20)
 POWER UNIT (AVR-488 E3 model only)
 XM_POWER PARTS
 DSP/HDMI_POWER PARTS