

DENON

Ver. 4

Please refer to the
MODIFICATION NOTICE.

SERVICE MANUAL

MODEL	JP	E3	E2	EK	EA	E1	E1K	E1C
AVR-1911 		✓	✓					✓
AVR-791		✓			✓ 			

AV SURROUND RECEIVER

• For purposes of improvement, specifications and design are subject to change without notice.

• Please use this service manual with referring to the operating instructions without fail.

• Some illustrations using in this service manual are slightly different from the actual set.

SAFETY PRECAUTIONS

The following check should be performed for the continued protection of the customer and service technician.

LEAKAGE CURRENT CHECK

Before returning the unit to the customer, make sure you make either (1) a leakage current check or (2) a line to chassis resistance check. If the leakage current exceeds 0.5 milliamps, or if the resistance from chassis to either side of the power cord is less than 460 kohms, the unit is defective.

Be sure to test for leakage current with the AC plug in both polarities, in addition, in each power ON, OFF and STANDBY mode, if applicable.

CAUTION Please heed the points listed below during servicing and inspection.

◎ **Heed the cautions!**

Spots requiring particular attention when servicing, such as the cabinet, parts, chassis, etc., have cautions indicated on labels. Be sure to heed these cautions and the cautions indicated in the handling instructions.

◎ **Caution concerning electric shock!**

(1) An AC voltage is impressed on this set, so touching internal metal parts when the set is energized could cause electric shock. Take care to avoid electric shock, by for example using an isolating transformer and gloves when servicing while the set is energized, unplugging the power cord when replacing parts, etc.

(2) There are high voltage parts inside. Handle with extra care when the set is energized.

◎ **Caution concerning disassembly and assembly!**

Through great care is taken when manufacturing parts from sheet metal, there may in some rare cases be burrs on the edges of parts which could cause injury if fingers are moved across them. Use gloves to protect your hands.

◎ **Only use designated parts!**

The set's parts have specific safety properties (fire resistance, voltage resistance, etc.). For replacement parts, be sure to use parts which have the same properties. In particular, for the important safety parts that are marked \triangle on wiring diagrams and parts lists, be sure to use the designated parts.

◎ **Be sure to mount parts and arrange the wires as they were originally!**

For safety reasons, some parts use tape, tubes or other insulating materials, and some parts are mounted away from the surface of printed circuit boards. Care is also taken with the positions of the wires and clamps are used to keep wires away from heating and high voltage parts, so be sure to set everything back as it was originally.

◎ **Inspect for safety after servicing!**

Check that all screws, parts and wires removed or disconnected for servicing have been put back in their original positions, inspect that no parts around the area that has been serviced have been negatively affected, conduct an insulation check on the external metal connectors and between the blades of the power plug, and otherwise check that safety is ensured.

(Insulation check procedure)

Unplug the power cord from the power outlet, disconnect the antenna, plugs, etc., and turn the power switch on. Using a 500V insulation resistance tester, check that the inplug and the externally exposed metal parts (antenna terminal, headphones terminal, input terminal, etc.) is 1M Ω or greater. If it is less, the set must be inspected and repaired.

CAUTION Concerning important safety parts

Many of the electric and structural parts used in the set have special safety properties. In most cases these properties are difficult to distinguish by sight, and using replacement parts with higher ratings (rated power and withstand voltage) does not necessarily guarantee that safety performance will be preserved. Parts with safety properties are indicated as shown below on the wiring diagrams and parts lists in this service manual. Be sure to replace them with parts with the designated part number.

(1) Schematic diagrams Indicated by the \triangle mark.

(2) Parts lists Indicated by the \triangle mark.

Using parts other than the designated parts could result in electric shock, fires or other dangerous situations.

NOTE FOR SCHEMATIC DIAGRAM

WARNING:

Parts marked with this symbol \triangle have critical characteristics. Use ONLY replacement parts recommended by the manufacturer.

CAUTION:

Before returning the unit to the customer, make sure you make either (1) a leakage current check or (2) a line to chassis resistance check. If the leakage current exceeds 0.5 milliamps, or if the resistance from chassis to either side of the power cord is less than 460 kohms, the unit is defective.

WARNING:

DO NOT return the unit to the customer until the problem is located and corrected.

NOTICE:

ALL RESISTANCE VALUES IN OHM. k=1,000 OHM / M=1,000,000 OHM

ALL CAPACITANCE VALUES IN MICRO FARAD. P=MICRO-MICRO FARAD EACH VOLTAGE AND CURRENT ARE MEASURED AT NO SIGNAL INPUT CONDITION. CIRCUIT AND PARTS ARE SUBJECT TO CHANGE WITHOUT PRIOR NOTICE.

NOTE FOR PARTS LIST

- Parts for which "nsp" is indicated on this table cannot be supplied.
- When ordering of part, clearly indicate "1" and "I" (i) to avoid mis-supplying.
- Ordering part without stating its part number can not be supplied.
- Part indicated with the mark "★" is not illustrated in the exploded view.
- Not including General-purpose Carbon Film Resistor in the P.W.Board parts list. (Refer to the Schematic Diagram for those parts.)
- Not including General-purpose Carbon Chip Resistor in the P.W.Board parts list. (Refer to the Schematic Diagram for those parts.)

WARNING: Parts marked with this symbol \triangle have critical characteristics. Use ONLY replacement parts recommended by the manufacturer.

● Resistors

Ex.:

RN	14K	2E	182	G	FR
Type	Shape and performance	Power	Resistance	Allowable error	Others

RD: Carbon	2B: 1/8 W	F: $\pm 1\%$	P: Pulse-resistant type
RC: Composition	2E: 1/4 W	G: $\pm 2\%$	NL: Low noise type
RS: Metal oxide film	2H: 1/2 W	J: $\pm 5\%$	NB: Non-burning type
RW: winding	3A: 1 W	K: $\pm 10\%$	FR: Fuse-resistor
RN: Metal film	3D: 2 W	M: $\pm 20\%$	F: Lead wire forming
RK: Metal mixture	3F: 3 W		
	3H: 5 W		

* Resistance

$\frac{1}{\uparrow} \frac{8}{\uparrow} \frac{2}{\uparrow} \Rightarrow 1800\text{ohm}=1.8\text{kohm}$
 Indicates number of zeros after effective number.
 2-digit effective number.

$\frac{1}{\uparrow} \frac{R}{\uparrow} \frac{2}{\uparrow} \Rightarrow 1.2\text{ohm}$
 1-digit effective number.
 2-digit effective number, decimal point indicated by R.
 Units: ohm

● Capacitors

Ex.:

CE	04W	1H	3R2	M	BP
Type	Shape and performance	Dielectric strength	Capacity	Allowable error	Others

CE: Aluminum foil electrolytic	0J: 6.3 V	F: $\pm 1\%$	HS: High stability type
CA: Aluminium solid electrolytic	1A: 10 V	G: $\pm 2\%$	BP: Non-polar type
CS: Tantalum electrolytic	1C: 16 V	J: $\pm 5\%$	HR: Ripple-resistant type
CQ: Film	1E: 25 V	K: $\pm 10\%$	DL: For charge and discharge
CK: Ceramic	1V: 35 V	M: $\pm 20\%$	HF: For assuring high frequency
CC: Ceramic	1H: 50 V	Z: $\pm 80\%$	U: UL part
CP: Oil	2A: 100 V	-: -20%	C: CSA part
CM: Mica	2B: 125 V	P: +100%	W: UL-CSA part
CF: Metallized	2C: 160 V	C: $\pm 0.25\text{pF}$	F: Lead wire forming
CH: Metallized	2D: 200 V	D: $\pm 0.5\text{pF}$	
	2E: 250 V	=: Others	
	2H: 500 V		
	2J: 630 V		

* Capacity (electrolyte only)

$\frac{2}{\uparrow} \frac{2}{\uparrow} \frac{2}{\uparrow} \Rightarrow 2200 \mu\text{F}$
 Indicates number of zeros after effective number.
 Units: μF .

$\frac{2}{\uparrow} \frac{R}{\uparrow} \frac{2}{\uparrow} \Rightarrow 2.2 \mu\text{F}$
 1-digit effective number.
 2-digit effective number, decimal point indicated by R
 Units: μF .

* Capacity (except electrolyte)

$\frac{2}{\uparrow} \frac{2}{\uparrow} \frac{2}{\uparrow} \Rightarrow 2200\text{pF}=0.0022 \mu\text{F}$
 Indicates number of zeros after effective number. (More than 2)
 2-digit effective number.
 Units:pF

$\frac{2}{\uparrow} \frac{2}{\uparrow} \frac{1}{\uparrow} \Rightarrow 220\text{pF}$
 Indicates number of zeros after effective number. (0 or 1)
 2-digit effective number.
 Units:pF

When the dielectric strength is indicated in AC,"AC" is included after the dielectric strength value.

TECHNICAL SPECIFICATIONS

□ Audio Section

• Power amplifier

Rated output :

Front :	90 W + 90 W (8 Ω, 20 Hz – 20 kHz with 0.08 % T.H.D.) 125 W + 125 W (6 Ω, 1 kHz with 0.7 % T.H.D.) 140W+140W(6 Ω, JEITA)
Center :	90 W (8 Ω, 20 Hz – 20 kHz with 0.08 % T.H.D.) 125 W (6 Ω, 1 kHz with 0.7 % T.H.D.) 140W(6 Ω, JEITA)
Surround :	90 W + 90 W (8 Ω, 20 Hz – 20 kHz with 0.08 % T.H.D.) 125 W + 125 W (6 Ω, 1 kHz with 0.7 % T.H.D.) 140W+140W(6 Ω, JEITA)
Surround back:	90 W + 90 W (8 Ω, 20 Hz – 20 kHz with 0.08 % T.H.D.) 125 W + 125 W (6 Ω, 1 kHz with 0.7 % T.H.D.) 140W+140W(6 Ω, JEITA)

Output connectors : 6 – 16 Ω

• Analog

Input sensitivity/Input impedance : 200 mV/47 kΩ

Frequency response: 10 Hz – 100 kHz — +1, –3 dB (DIRECT mode)

S/N : 100 dB (IHF–A weighted, DIRECT mode)

□ Video Section

• Standard video connectors

Input/output level and impedance : 1 Vp-p, 75 Ω

Frequency response : 5 Hz – 10 MHz — +1, –3 dB

□ HD Radio section (for 1911E3)

[FM](Note: μV at 75 Ω, 0 dBf = 1 x 10⁻¹⁵ W)

Receiving Range :

[FM] 87.5 MHz – 107.9 MHz [AM]530 kHz – 1710 kHz

Usable Sensitivity :

[FM]1.5 μV (14.8 dBf) [AM]20 μV

S/N (IHF-A) :

[FM]MONO 78 dB [AM]
STEREO 68 dB
HD 85 dB 85 dB

Total harmonic Distortion (at 1 kHz) :

[FM]MONO 0.1 % [AM]
STEREO 0.2 %
HD 0.02 % 0.02 %

□ Tuner section (for 1911E2,1911E1C,791E3,791EA)

[FM](Note: μV at 75 Ω, 0 dBf = 1 x 10⁻¹⁵ W)

Receiving Range (for 791E3) :

[FM] 87.5 MHz – 107.9 MHz [AM]520 kHz – 1710 kHz

Receiving Range (for 1911E2,1911E1C,791EA) :

[FM] 87.5 MHz – 108.0 MHz [AM]522 kHz – 1611 kHz

Usable Sensitivity :

[FM]1.2 μV (12.8 dBf) [AM]18 μV

50 dB Quieting Sensitivity (for 791E3) :

[FM]MONO 2.8 μV (20.2 dBf)

50 dB Quieting Sensitivity (for 1911E2,1911E1C,791EA) :

[FM]MONO 2.0 μV (17.3 dBf)
STEREO 42 μV (34.5 dBf)

S/N (IHF-A) (for 791E3) :

[FM]MONO 70 dB
STEREO 67 dB

S/N (IHF-A) (for 1911E2,1911E1C,791EA) :

[FM]MONO 72 dB
STEREO 67 dB

Total harmonic Distortion (at 1 kHz) (for 791E3) :

[FM]MONO 0.7 %
STEREO 1.0 %

Total harmonic Distortion (at 1 kHz) (for 1911E2,1911E1C,791EA) :

[FM]MONO 0.3 %
STEREO 0.7 %

□ General

Power supply : AC 120 V, 60 Hz (for 1911E3,791E3)
AC 230 V, 50 Hz (for 1911E2,791EA)
AC 220 V, 50 Hz (for 1911E1C)

Power consumption :

460 W
0.1 W (Standby)
3 W (CEC standby)

Maximum external dimensions :

434 (W) x 171 (H) x 381 (D) mm

Weight : 10.2 kg

□ Remote Control Unit (RC-1146)

Batteries : R6/AA Type (two batteries)

Maximum external dimensions : 53 (W) x 224 (H) x 28 (D) mm

Weight : 160 g (including batteries)

DIMENSION

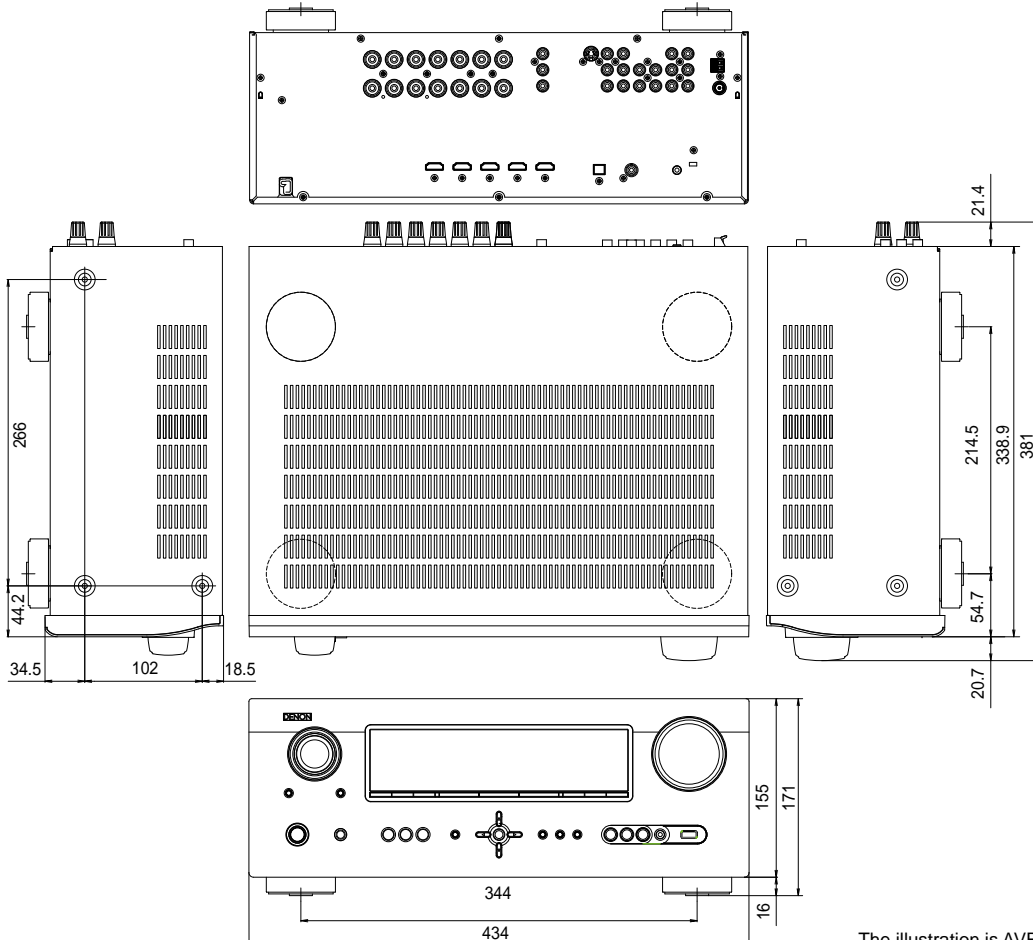

The illustration is AVR-791 E3 model.

CAUTION IN SERVICING

Initializing AV SURROUND RECEIVER

AV SURROUND RECEIVER initialization should be performed when the μ com, peripheral parts of μ com, and Digital P.W.B. are replaced.

1. Turn off the power using ON/STANDBY button.
2. Press ON/STANDBY button while simultaneously pressing SURROUND MODE ◀ and SURROUND MODE ▶ buttons.
3. Check that the entire display is flashing with an interval of about 1 second, and release your fingers from the 2 buttons and the microprocessor will be initialized.

Note:

- If step 3 does not work, start over from step 1.
- All user settings will be lost and this factory setting will be recovered when this initialization mode. So make sure to memorize your setting for restoring after the initialization.

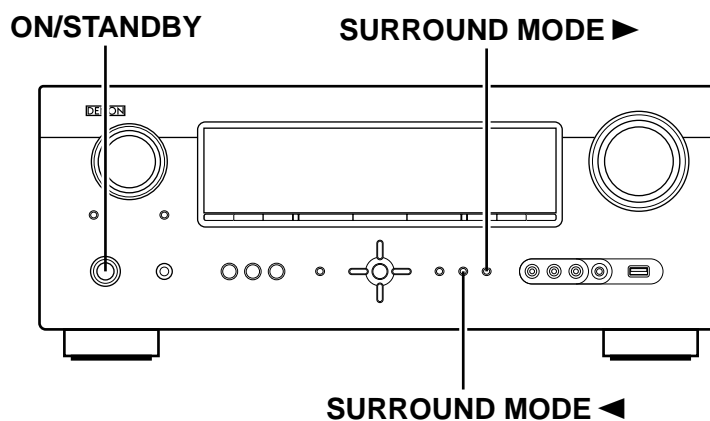

Service Jigs

When you repair the printing board, you can use the following JIG (Extension cable kit). Please order to Denon Official Service Distributor in your region if necessary.

8U-110084S : EXTENSION UNIT KIT : 1 Set 
(Refer to 20 page)

When you update the firmware, you can use the following JIG (RS232C to internal connector conversion adapter with 4P FFC cable kit). 
Please order to Denon Official Service Distributor in your region if necessary.

8U-210100S : WRITING KIT : 1 Set
(Refer to 22 page)

DISASSEMBLY

- Disassemble in order of the arrow of the figure of following flow.
- In the case of the re-assembling, assemble it in order of the reverse of the following flow.
- In the case of the re-assembling, observe "attention of assembling" it.
- If wire bundles are untied or moved to perform adjustment or parts replacement etc., be sure to rearrange them neatly as they were originally bundled or placed afterward.
Otherwise, incorrect arrangement can be a cause of noise generation.

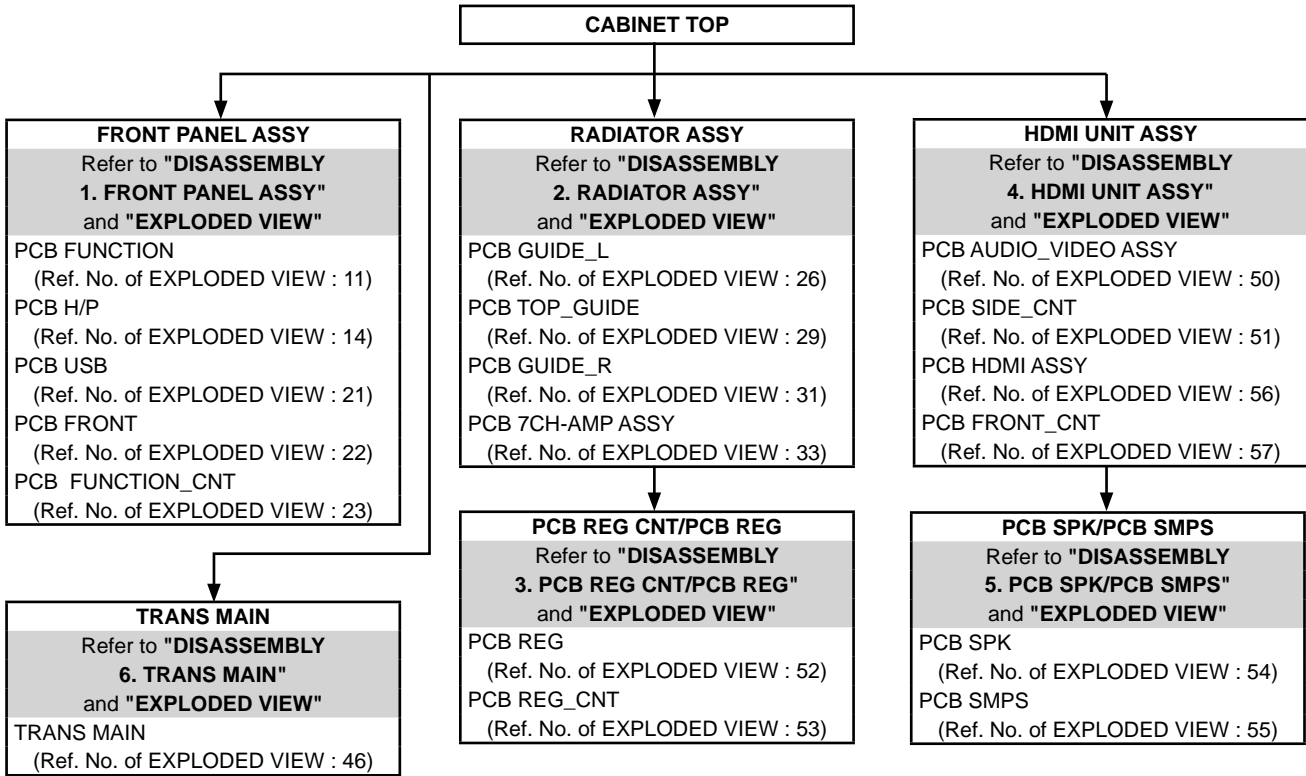

About the photos used for descriptions in the "DISASSEMBLY" section.

- The direction from which the photographs used herein were photographed is indicated at "Direction of photograph: ****" at the left of the respective photographs.
- Refer to the table below for a description of the direction in which the photos were taken.
- Photographs for which no direction is indicated were taken from above the product.
- The photograph is AVR-791 E3 model.

The viewpoint of each photograph (Photography direction)

[View from above]

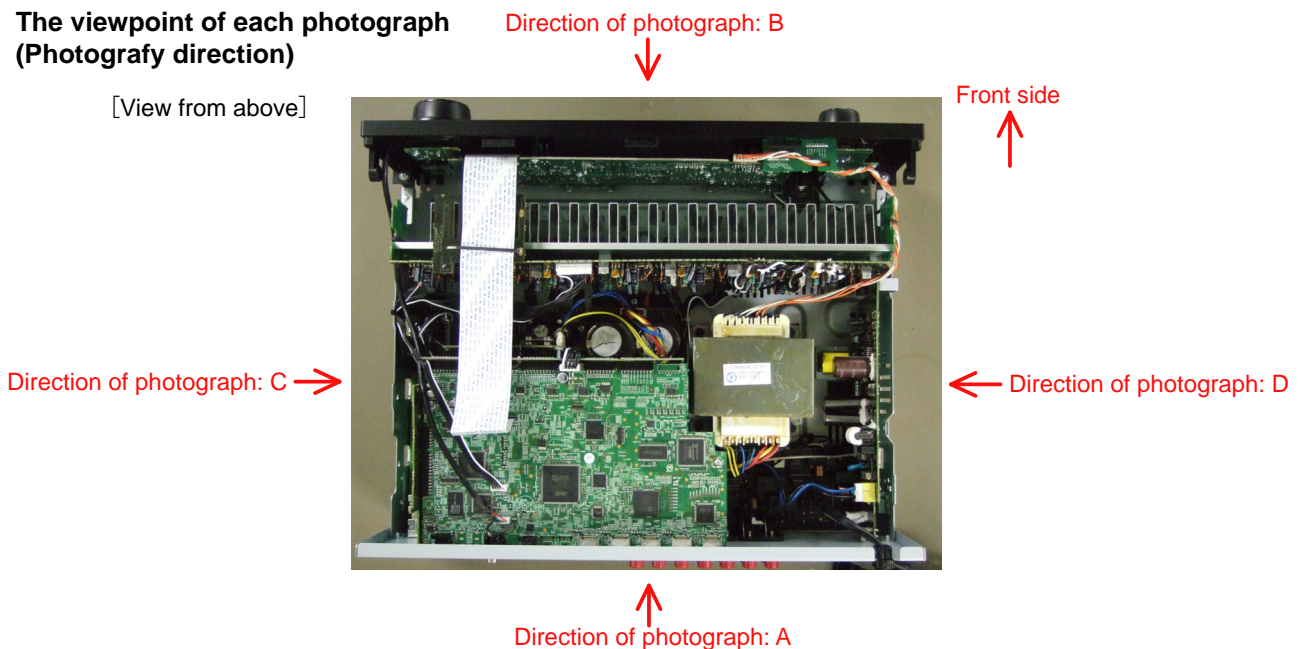

1. FRONT PANEL ASSY

Proceeding : CABINET TOP → FRONT PANEL ASSY

(1) Remove the screws.

View from bottom

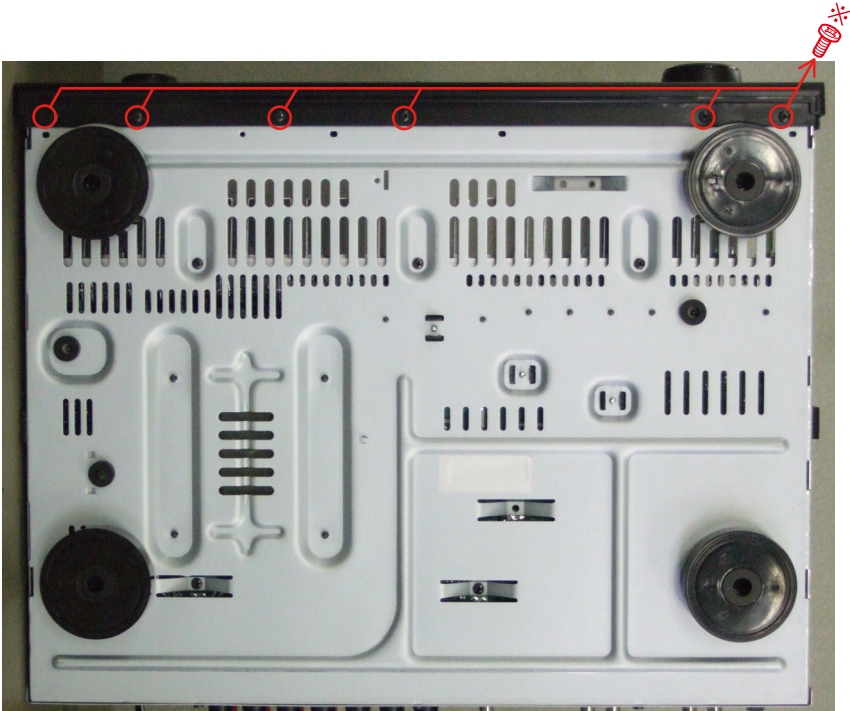

(2) Cut the wire clamp band, then disconnect the connector wires and FFC cable. Remove the screws.

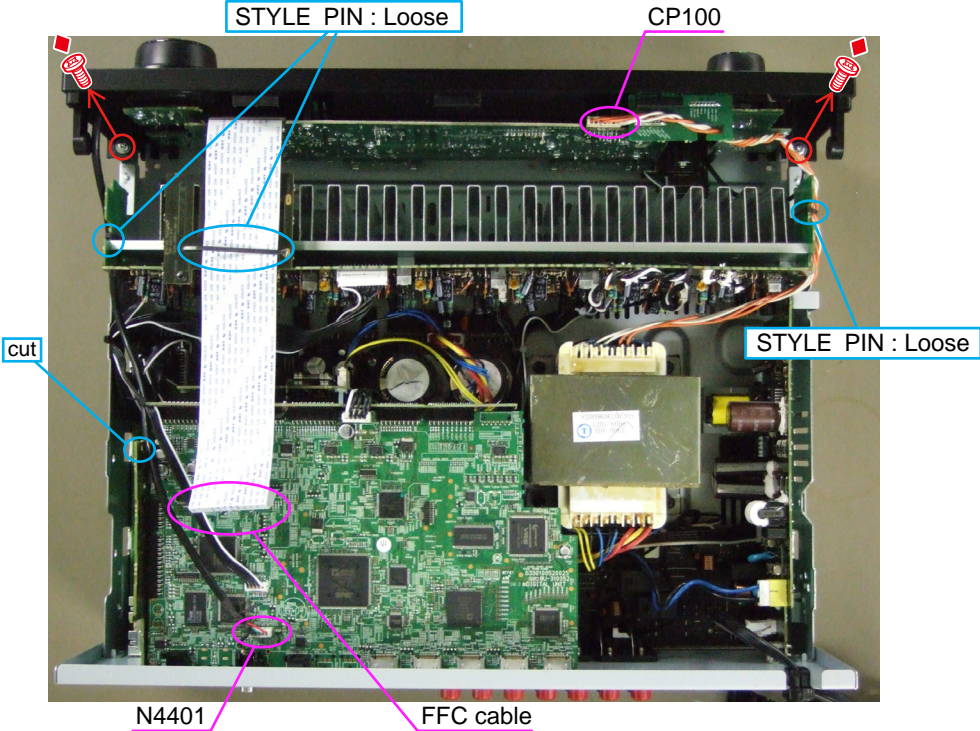

Please refer to "EXPLODED VIEW" for the disassembly method of each PCB included in FRONT PANEL ASSY.

2. RADIATOR ASSY

Proceeding : **CABINET TOP** → **RADIATOR ASSY**

(1) Remove the screws.

View from bottom

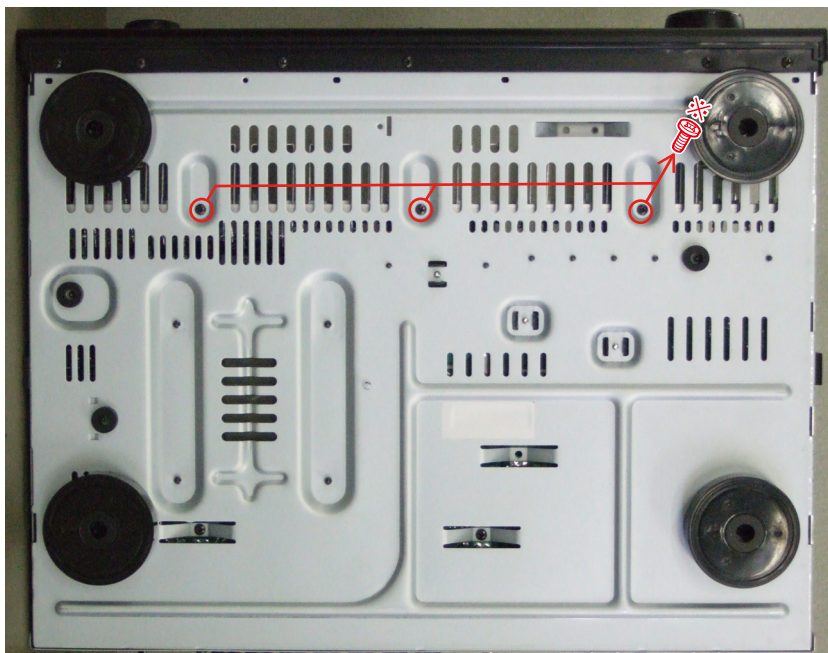

(2) Remove the screws.

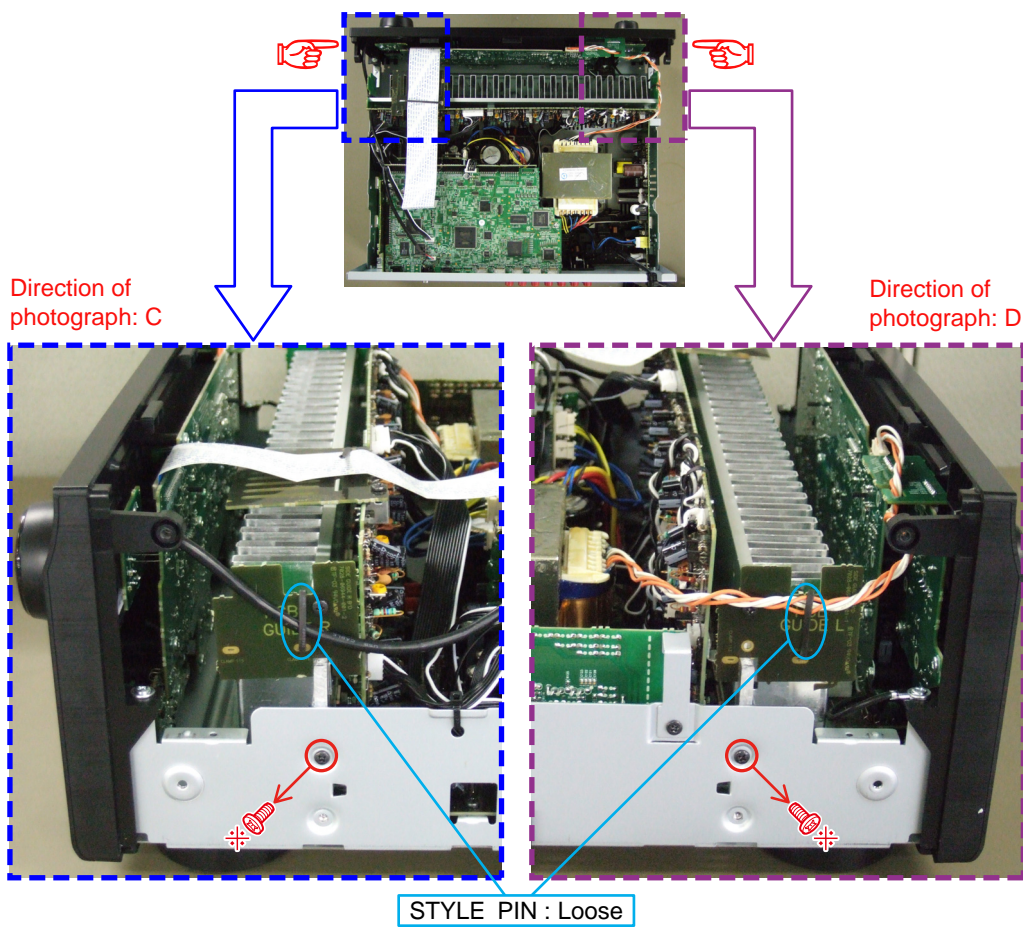

(3) Cut the wire clamp bands, then disconnect the connector wires and FFC cable.

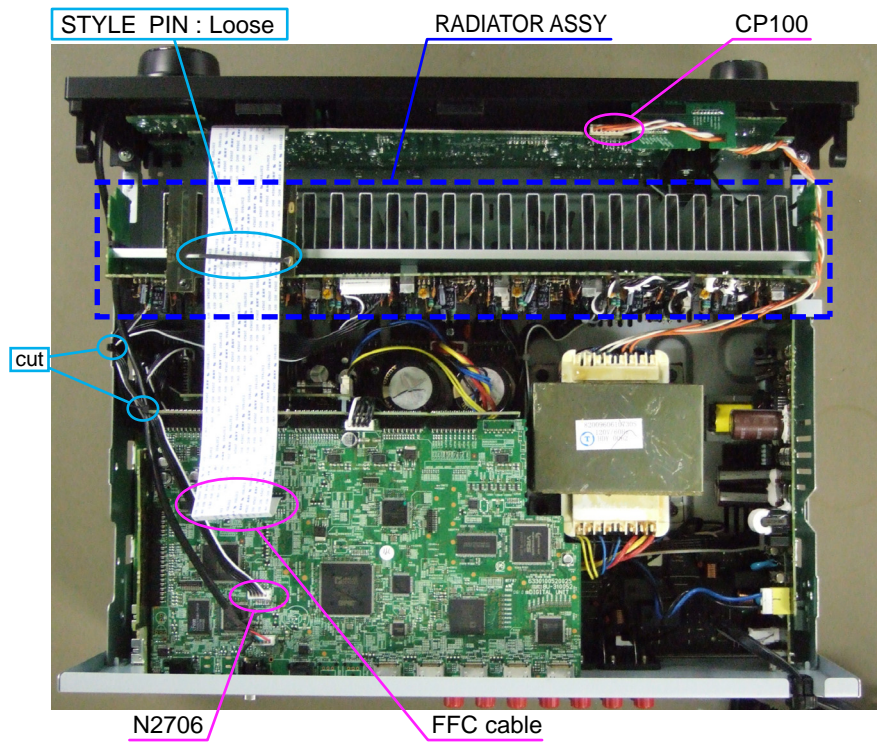

(4) Disconnect the connector wires.

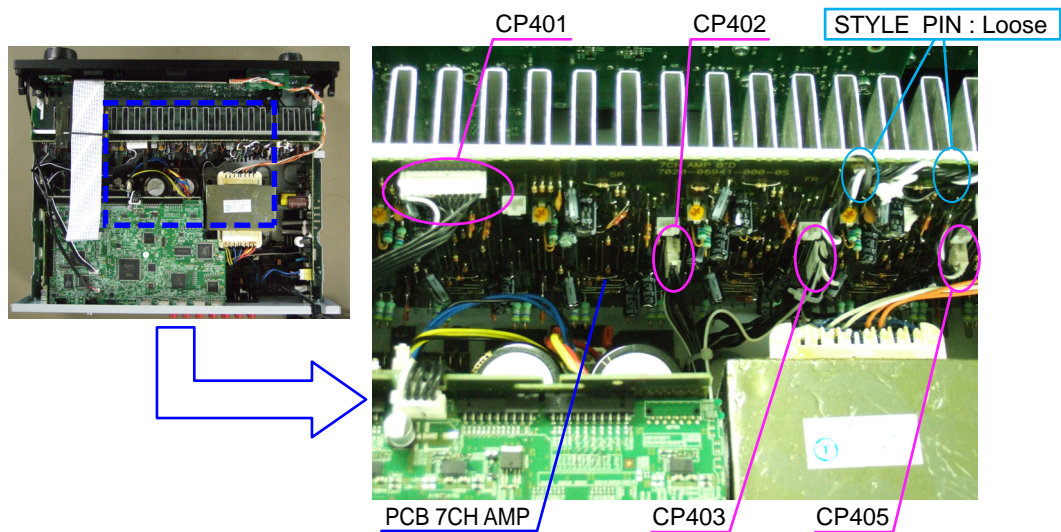

Please refer to "EXPLODED VIEW" for the disassembly method of each P.W.B included in RADIATOR ASSY.

3. PCB REG CNT/PCB REG

Proceeding : **CABINET TOP** → **RADIATOR ASSY** → **PCB REG CNT/PCB REG**

(1) Remove the screws.

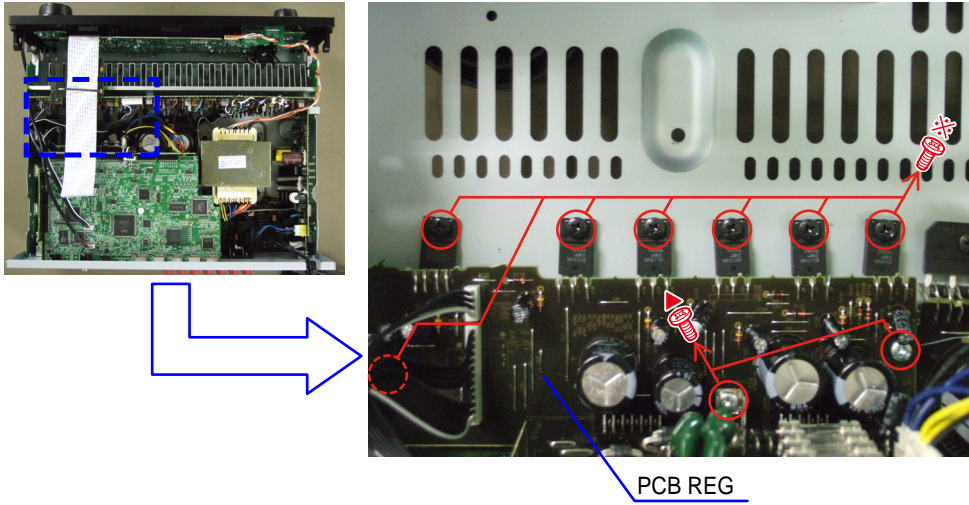

(2) Disconnect the connector wires and connector board..

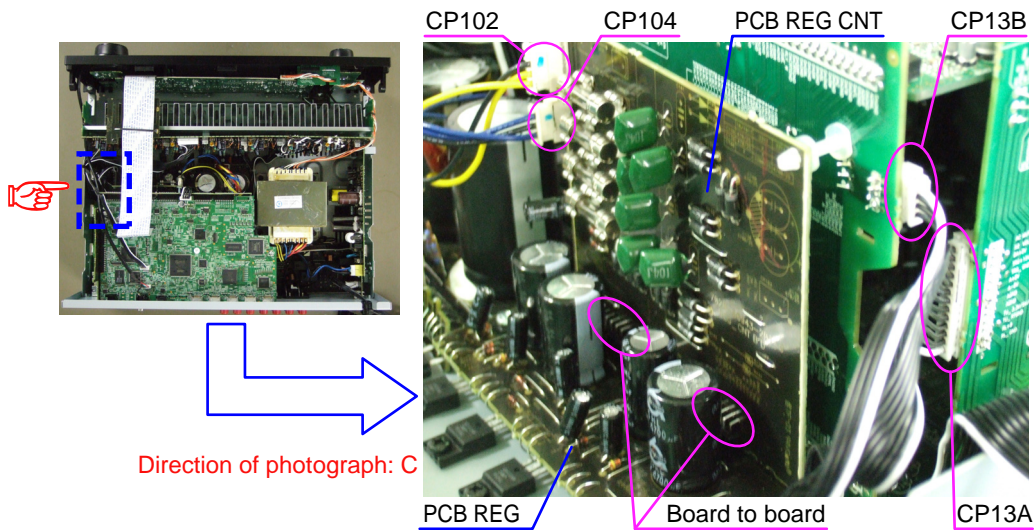

4. HDMI UNIT ASSY

Proceeding : **CABINET TOP** → **HDMI UNIT ASSY**

(1) Disconnect the connector wire and FFC cable.

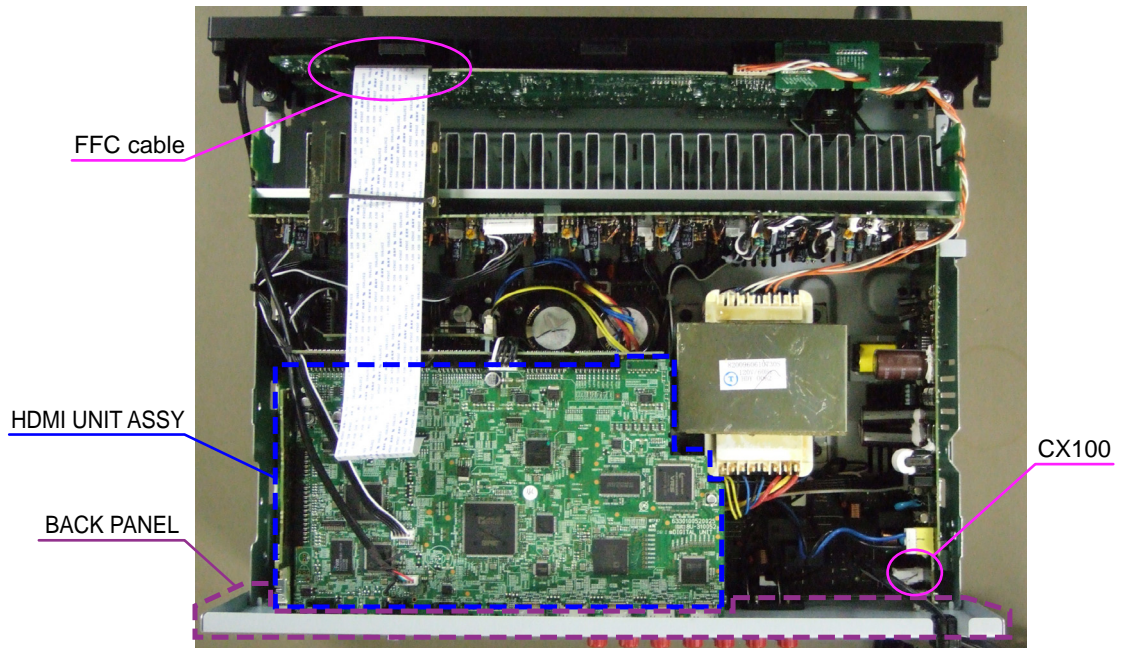

(2) Remove the screws, then remove the BACK PANEL.



(3) Cut the wire clamp band, then disconnect the and connector wires. Remove the screw.

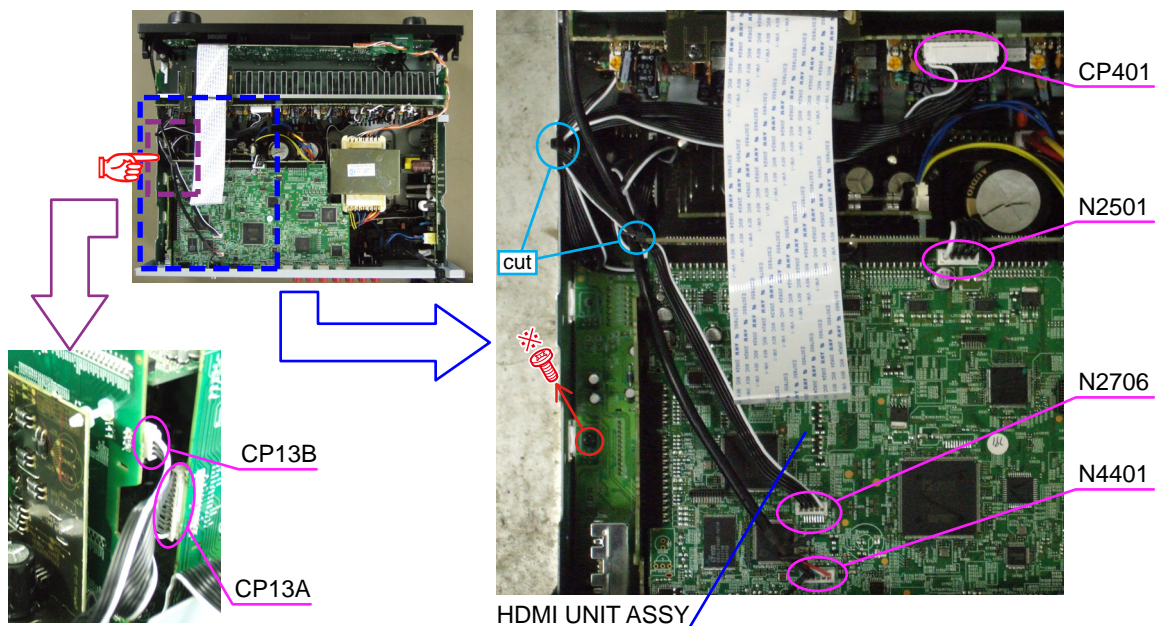

(4) Disconnect the connector, then remove the HDMI UNIT ASSY from the main unit.

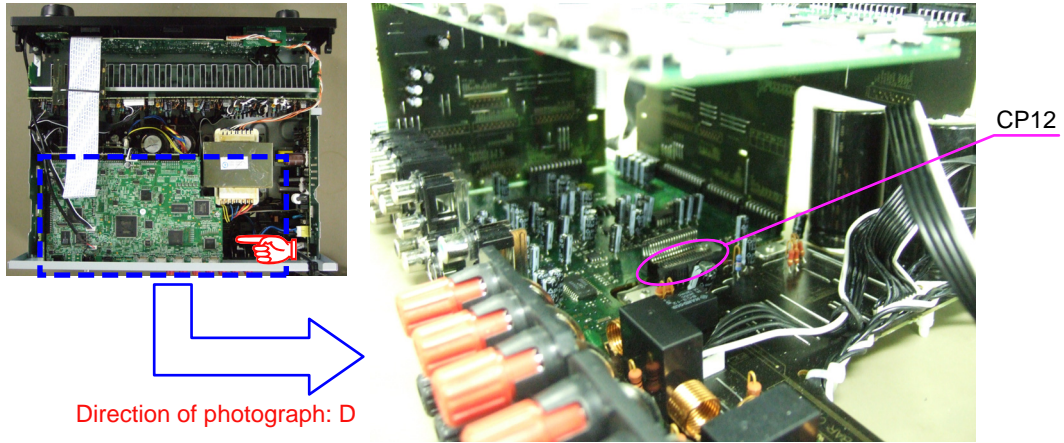

(5) Disconnect the connector board.

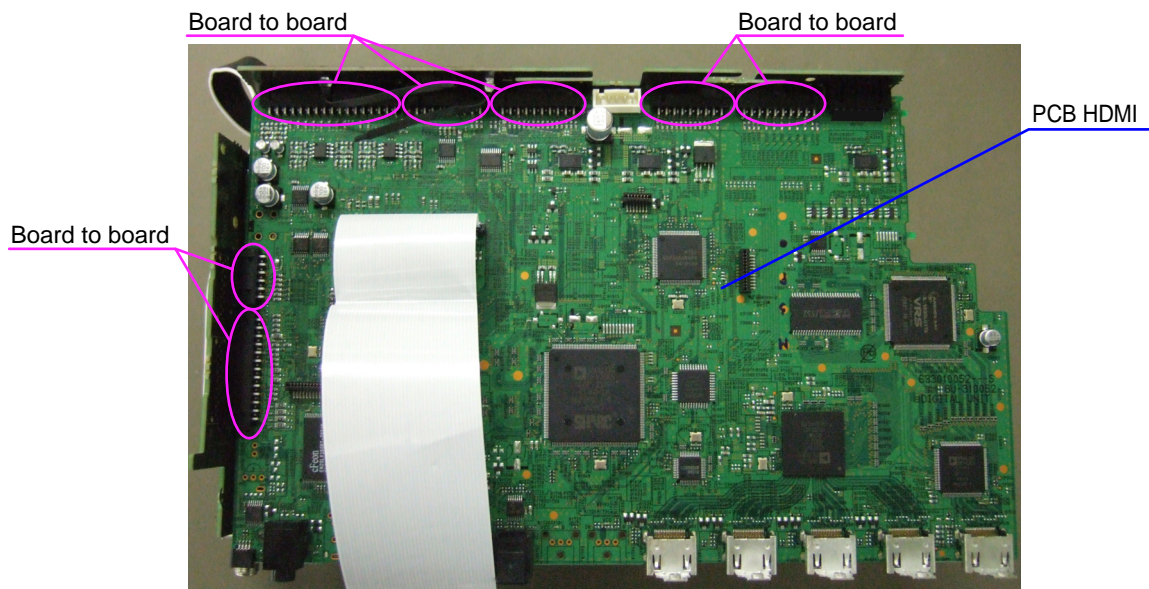

(6) Disconnect the connector board.

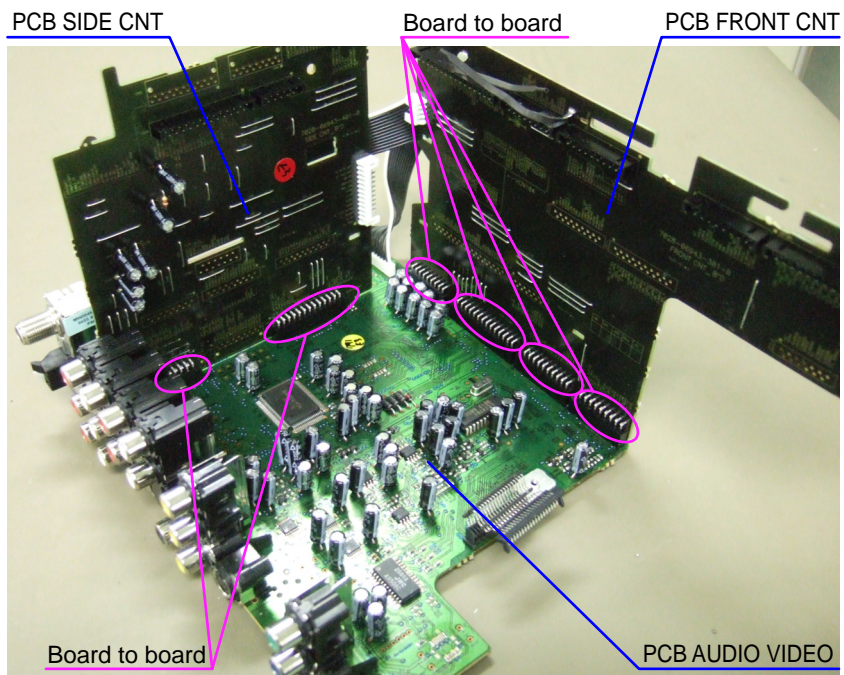

5. PCB SPK/PCB SMPS

Proceeding : **CABINET TOP** → **HDMI UNIT ASSY** → **PCB SPK/PCB SMPS**

- (1) Remove the Sheet, then remove the screws and SUPPORTER P.C.

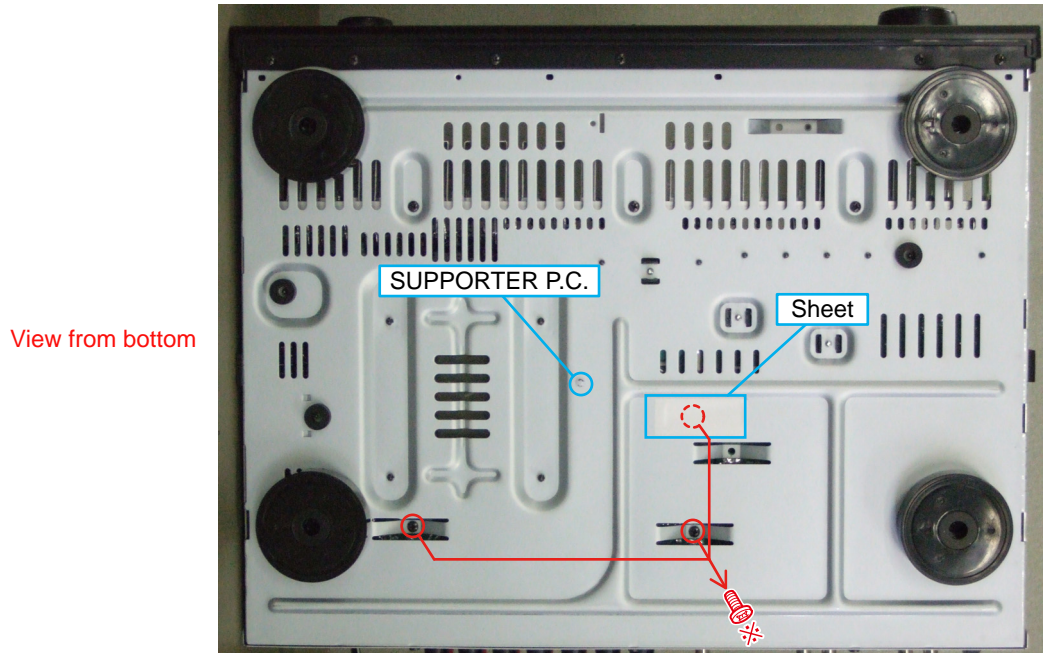

- (2) Disconnect the connector wire, then remove the screws.

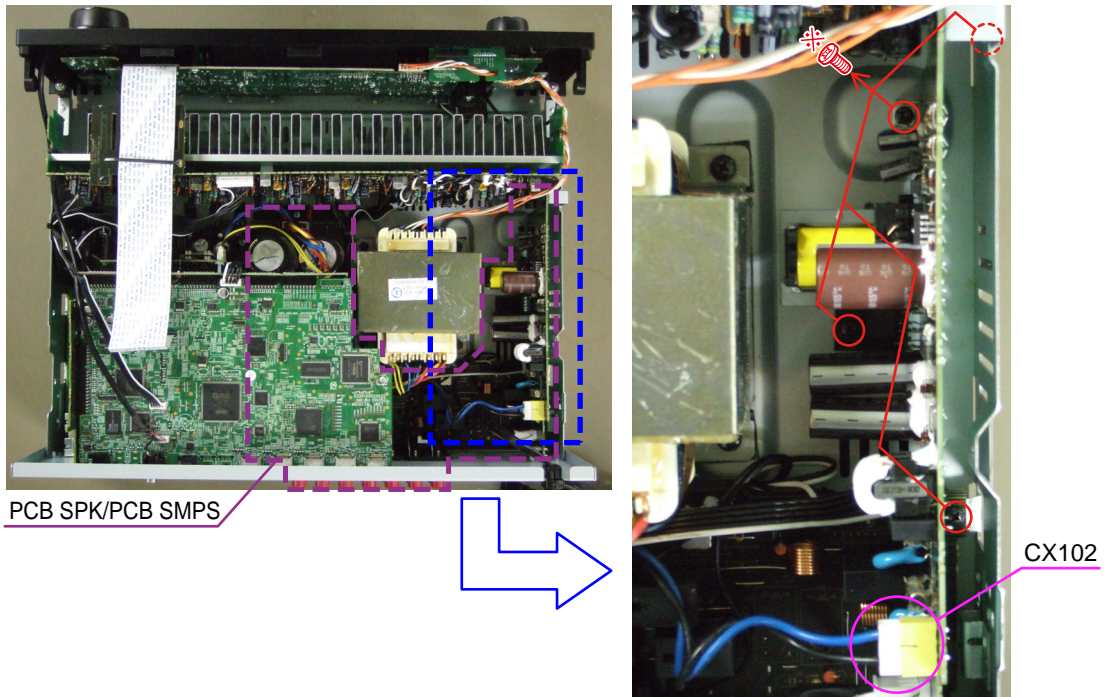

(3) Disconnect the connector wire, then remove the screws. Remove the PCB SPK/PCB SMPS from the main unit.

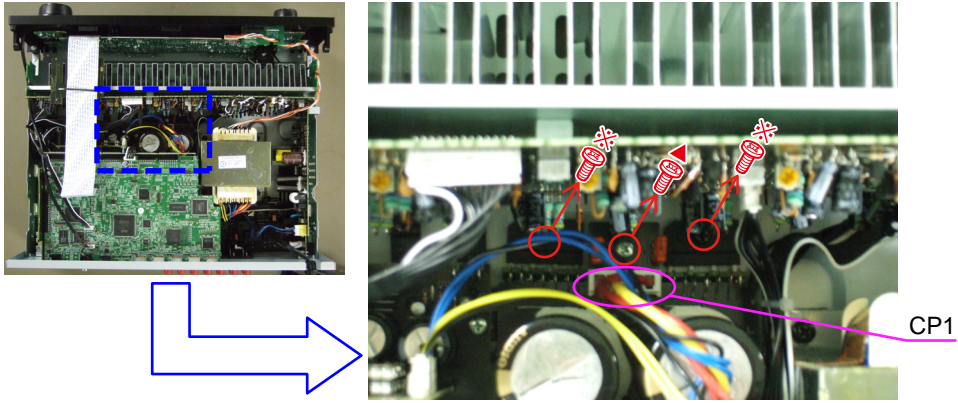

(4) Disconnect the connector board.

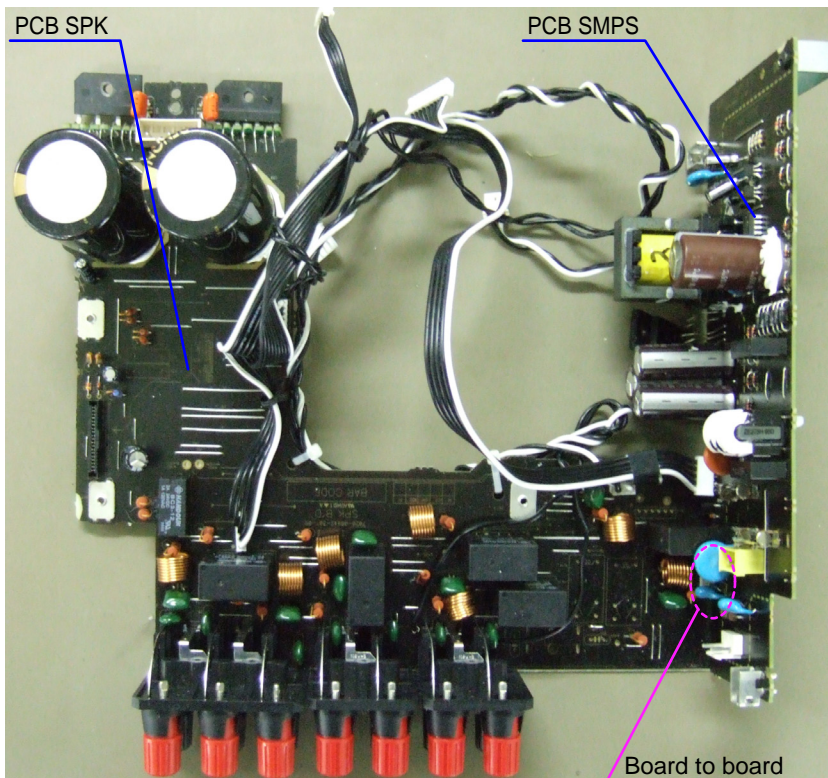

6. TRANS MAIN

Proceeding : **CABINET TOP** → **TRANS MAIN**

(1) Disconnect the connector wires, then remove the screws.

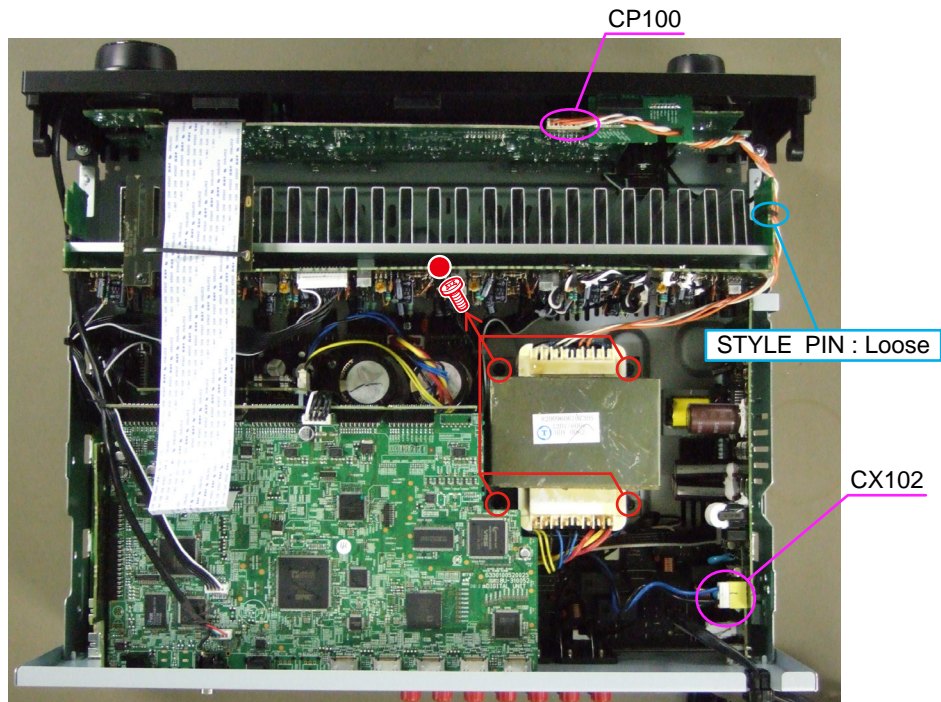

(2) Disconnect the connector wires.

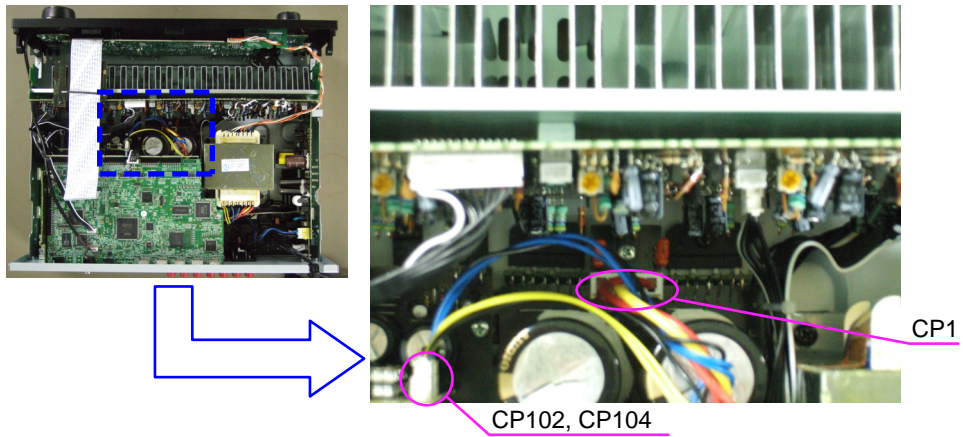

SPECIAL MODE

Special mode setting button

※ Press the ON/STANDBY button to turn on while pressing both buttons A and B at the same time.

Mode	Button A	Button B	Contents
µcom/DSP Version display mode	STATUS	DIMMER	Firmware versions such as Main, Sub, DSP are displayed in the FL manager. Errors are displayed when they occur. (Refer to 17 page.)
Errors checking mode (Displaying the protection history)	STATUS	MULT EQ	Displaying the protection history (Refer to 18 page.)
Initialization mode	SURROUND MODE ◀	SURROUND MODE ▶	Backup data initialization is carried out. (Refer to 5 page.)
Mode for switching tuner frequency step	DINAMIC EQ	DINAMIC VOLUME	---E2 model only--- Select with the SOURCE ◀▶▶▼ button. Change tuner frequency step to AM9k/FM50kHz STEP or AM:10k/FM:200kHz.
Mode for preventing remote control acceptance	DINAMIC VOLUME	RETURN	Operations using remote control are rejected. (Mode cancellation: Turn off power and execute the same button operations as when performing setup.)
Panel lock mode	DINAMIC EQ	ENTER	Operations using main unit panel buttons or master volume are rejected.
Panel lock mode (Remove Master volume)	DINAMIC EQ	CURSOR ▶	Operations using main unit panel buttons are rejected.
Cancellation of panel lock mode	DINAMIC EQ	RETURN	Panel lock mode is cancelled.

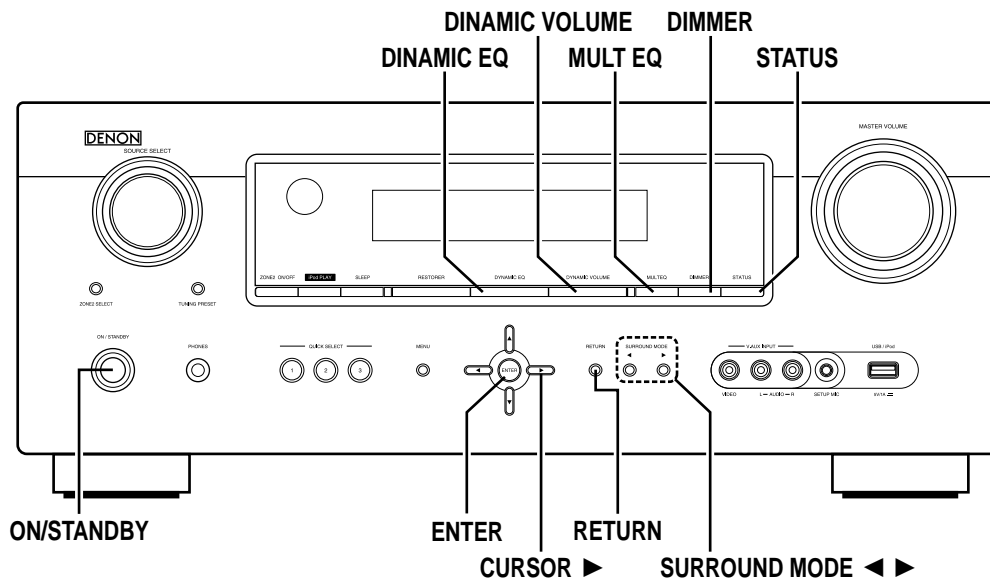

1. μ com/DSP Version display mode

1.1. Operation specifications

μ com/DSP version display mode:

When started up, the version information is displayed.

Starting up:

With the "DIMMER" and "STATUS" buttons pressed, press the "ON/STANDBY" button to turn the power on.

Now, press the "STATUS" button to the display the 2nd item information on the FL Display.

1.2. Display Order

Destination information → Main- μ com version → Main 1st Boot version → Sub- μ com version

→ Sub 1st Boot Loader Version → DSP version → APLD version → USB version

→ HD Radio SDK version (1911E3 model only) Δ → HD Radio BBP version (1911E3 model only) Δ

1.3. Error display

See the following table for each "Error information" display and its contents (status).

Display order is ①,②,③,④,⑤.

Condition	State	State
① Sub- μ com NG	No response from Sub- μ com	SUB ERROR 01
② DIR NG	No response from DIR	DIR ERROR 01
③ DSP1 NG	When DSP boot, executing DSP reset makes no change to DSP1 FLAG0 port "H".	DSP ERROR 01
	No change to DSP FLAG0 port "H" before issuing DSP command.	DSP ERROR 02
	When DSP data read, executing WRITE="L" makes no change to ACK="H".	DSP ERROR 03
	When DSP data read, executing REQ="L" makes no change to ACK="L".	DSP ERROR 04
	When DSP data write, executing WRITE="H" makes no change to ACK="H".	DSP ERROR 05
	When DSP data write, executing REQ="L" makes no change to ACK="L".	DSP ERROR 06
	When DSP special code boot, executing DSP reset makes no change to DSP FLAG0 port "H".	DSP ERROR 11
	No change to DSP FLAG0 port "H" before issuing DSP special read command.	DSP ERROR 12
	No change to DSP FLAG0 port "H" before DSP version read.	DSP ERROR 13
④ EEPROM NG	Error appeared in EEPROM checksum.(*** is a block address number.)	E2PROM ERR***
⑤ Both SUB/DSP /EEPROM OK		(No error display, version display only)

2. Errors checking mode (Displaying the protection history)

2.1. Operation specifications

Error mode (Displaying the protection history):

When started up, the error information is displayed.

Starting up:

•All model commonness

With the "STATUS" and "MULT EQ" buttons pressed, press the "ON/STANDBY" button to turn the power on. The error (protection history display) mode is set.

Now, press the "STATUS" button to turn on the FL display.

2.2. About the display on the FL display

When the "STATUS" button is pressed after setting the error (protection history display) mode, a history like the one shown below is displayed, depending on the conditions.

- (1) Normally (when there has been no protection incident)

FLD	N	O		P	R	O	T	E	C	T									
-----	---	---	--	---	---	---	---	---	---	---	--	--	--	--	--	--	--	--	--

- (2) For ASO (when the last protection incident was ASO protection)

FLD	P	R	T	:	A	S	O												
-----	---	---	---	---	---	---	---	--	--	--	--	--	--	--	--	--	--	--	--

Cause: The line between speaker terminals is shorted, or use speakers having impedance less than that specified.

Supplementary information: As the excess current is detected after operation of the speaker relay, the shorted speaker terminal and the connected speaker can be identified.

Turning on the power without correcting the abnormality will cause the protection function to work about 5 seconds later and the power supply will be shut off.

- (3) For DC (when the last protection incident was DC protection)

FLD	P	R	T	:	D	C													
-----	---	---	---	---	---	---	--	--	--	--	--	--	--	--	--	--	--	--	--

Cause: DC output of the power amplifier is abnormal.

Turning on the power without correcting the abnormality will cause the protection function to work about 5 seconds later and the power supply will be shut off.

- (4) For THERMAL (when the last protection incident was THERMAL protection)

FLD	P	R	T	:	T	H	E	R	M	A	L								
-----	---	---	---	---	---	---	---	---	---	---	---	--	--	--	--	--	--	--	--

Cause: The temperature of the heat sink is excessive.

Turning on the power without correcting the abnormality will cause the protection function to work about 5 seconds later and the power supply will be shut off.

* Additional causes of protection can be due to loose connections, associated components, Microprocessor, etc.

When the "STATUS" button is pressed again after the above protection history is displayed, the normal display reappears.

2.3. Clearing the protection history

There are two ways to clear the protection history, as described below.

- (1) Start up the error (protection display) mode, display the error, then press and hold in the "ENTER" button for 3 seconds.

FLD	:	T	H	E	R	M	A	L	T	H	E				
-----	---	---	---	---	---	---	---	---	---	---	---	--	--	--	--

↓
Press and hold in the "ENTER" button for 3 seconds.

FLD	:	P	R	T	:	C	L	E	A	R					
-----	---	---	---	---	---	---	---	---	---	---	--	--	--	--	--

↓
The above is displayed and the protection history is cleared.

FLD	:	N	O		P	R	O	T	E	C	T				
-----	---	---	---	--	---	---	---	---	---	---	---	--	--	--	--

- (2) Initialize. (Refer to "Initializing AV SURROUND RECEIVER" 5 page.)

※ If you want to save a backup, use the method in 2.3.(1) above.

Warning indication by the POWER LED

If the power is turned off when a protection incident has been detected, the POWER LED (red) flashes as a warning according to the conditions in which the protection incident occurred.

- (1) ASO/DC PROTECTION : Flashes in cycles of 0.5 seconds (0.25 seconds lit, 0.25 seconds off)
- (2) THERMAL PROTECTION : Flashes in cycles of 2 seconds (1 second lit, 1 second off)

JIG FOR SERVICING

When you repair the printing board, you can use the following JIG (Extension cable kit).
Please order to DENON Official Service. Distributor in your region if necessary.

Note: When the connection which is wrong in the JIG (EXTENSION UNIT KIT) is done it becomes cause of damage.

8U-110084S : EXTENSION UNIT KIT : 1 Set 

• Connection of PCB HDMI JIG

-Preparation-

8U-110084S : EXTENSION UNIT KIT : 1 Set 
 Insulation sheet (Do not supply it) : 1 sheet
 Ground lead (Do not supply it) : 1 pc

-Procedures-

(1) Remove the screws.



(2) Disconnect the connector board.

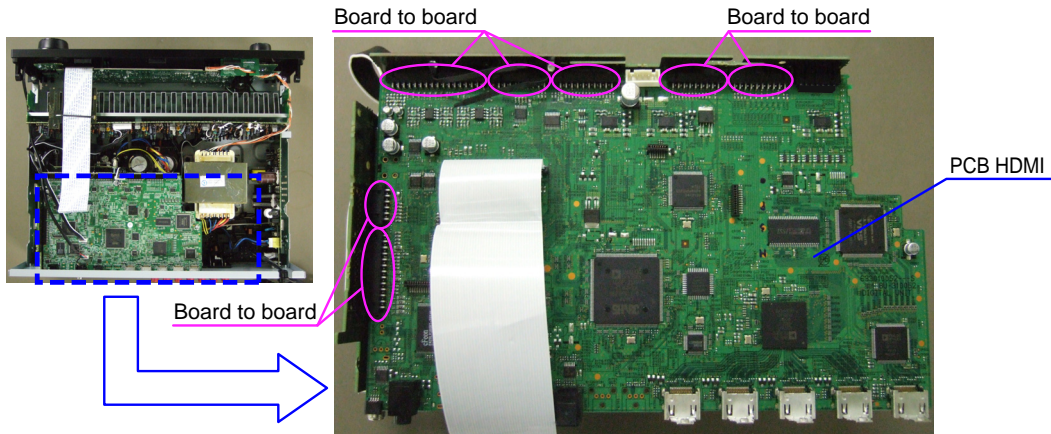

(3) PCB HDMI is detached from the chassis, and it puts it into the state turned inside out.

Please pave an insulation sheet that is larger than PCB HDMI under PCB.
 ※ Connect the ground point of PCB to the chassis with a ground lead or the like.

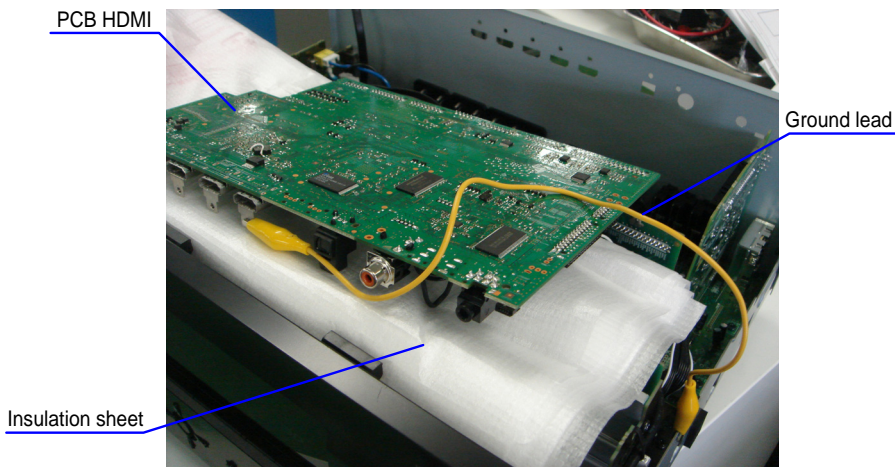

(4) Connect the four extension jig cables.

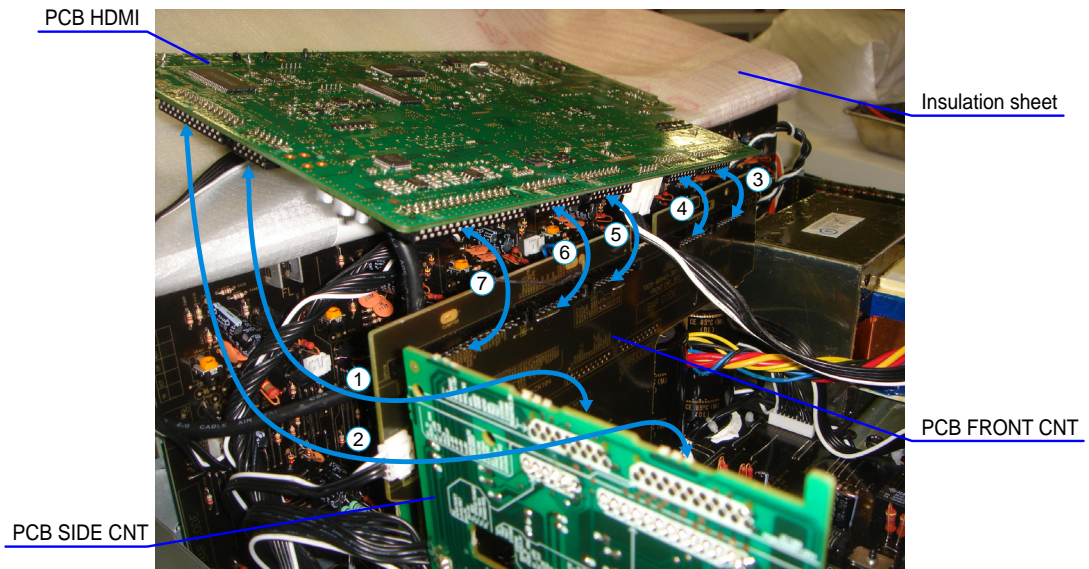

Connection table of Board to Board

No.	Pin	Ref. No.	PCB		Ref. No.	PCB
①	11 pin	CP3	SIDE CNT	↔	N2709	HDMI
②	25 pin	CP4	SIDE CNT	↔	N2708	HDMI
③	19 pin	CP105	FRONT CNT	↔	N2701	HDMI
④	17 pin	CP106	FRONT CNT	↔	N2702	HDMI
⑤	19 pin	CP108	FRONT CNT	↔	N2704	HDMI
⑥	17 pin	CP109	FRONT CNT	↔	N2705	HDMI
⑦	33 pin	CP110	FRONT CNT	↔	N2707	HDMI

ABOUT REPLACE THE MICROPROCESSOR WITH A NEW ONE

When replaced of the U-PRO (Microprocessor) or the Flash ROM, confirm contents of the following.

PWB Name	Ref. No.	Description	After replaced	Remark
DIGITAL	U3102	R5F64169DFD	B	SOFTWARE: Main
DIGITAL	U3301	R5F3650KNFB	B	SOFTWARE: Sub
DIGITAL	U1903	EN29LV160BB-70TIP	B	SOFTWARE: DSP ROM
DIGITAL	U1707	EPM3032A	B	SOFTWARE: Audio PLD

After replaced

A : Mask ROM (With software). No need write-in of software to the microprocessor.

B : Flash ROM (With software). Usually, no need write-in of software. But, when the software was updated, you should be write-in of the new software to the microprocessor or flash ROM. Please check the software version.

C : Empty Flash ROM (Without software). You should be write-in of the software to the microprocessor or flash ROM.

Refer to "Update procedure" or "writing procedure", when you should be write-in the software.

VERSION UPGRADE PROCEDURE OF FIRMWARE

1. Preparations before starting the operation

- (1) Personal Computer (Installed "DFW_0041_AVR1911_AVR791_(Rev.1.0.6).exe").
- (2) RS-232 cable (9P (Male), Straight).
- (3) 8U-210100 Writing Kit.

2. Connection of the AV receiver/amplifier

- (1) Confirm the power on/off switch of the AV receiver/amplifier is turning off.
- (2) Connect the update terminal of AV receiver/amplifier with the "Writing Kit".
- (3) Connect the RS-232C cable from PC with the "Writing Kit".

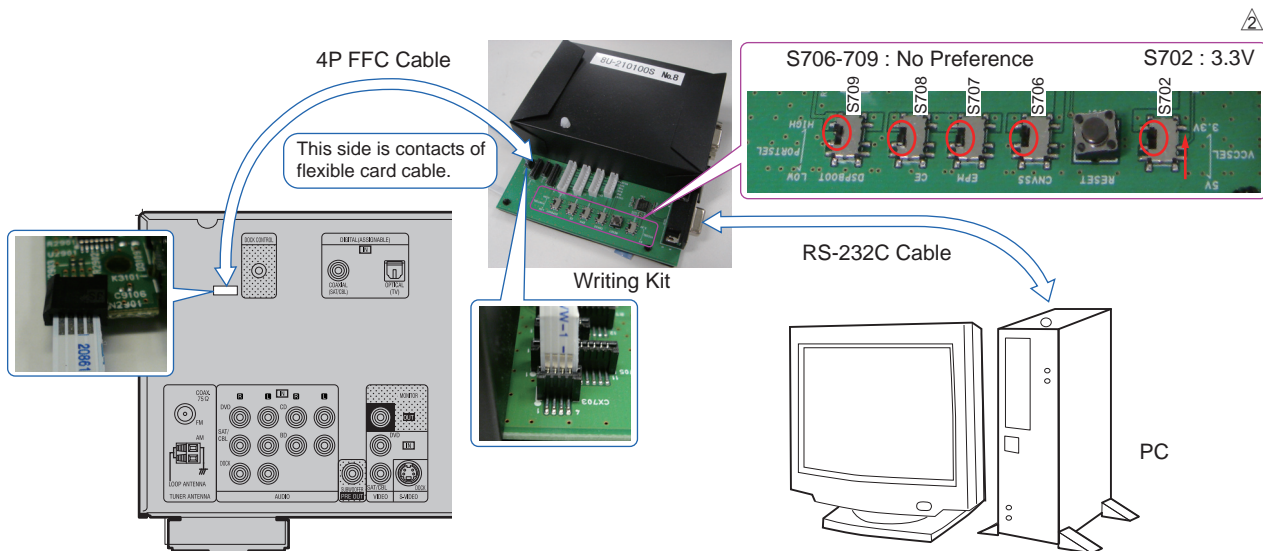

3. Turn on the AV receiver/amplifier

Operate the following. Turn on the AV receiver.

- (1) Connect the power cable to the AC outlet while simultaneously pushing the "SURROUND MODE ◀" button and the "RETURN" button of the front panel.
- (2) Confirm the power indicator is green and "WRITTING" is displayed in the front panel.

4. Run the DFW

Run the “DFW_0041_AVR1911_AVR791_(Rev.1.0.6).exe)” on desktop of PC.



5. Communication check

(1) Click the “Check Comm.” button.

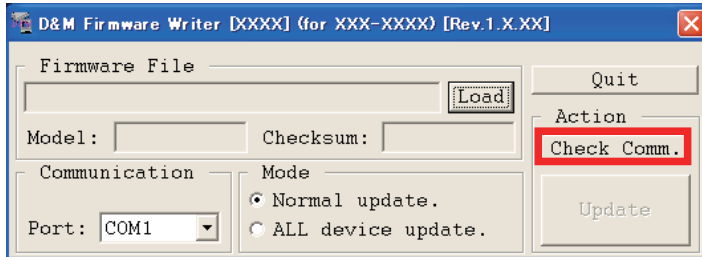

(2) When connection is good, then you can see the “Communication check OK.” message.

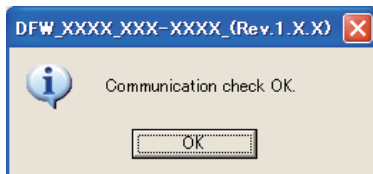

(3) If connection is not good, then you can see the “Communication check NG” message.

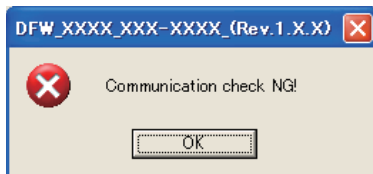

Please confirm the following

- (a) Check the connection of the AV receiver/amplifier and PC. (refer to “2. Connection of the AV receiver/amplifier”)
- (b) Check the operation mode of the AV receiver/amplifier. (refer to “3.Turn on the AV receiver/amplifier”)
- (c) Check the selection of the RS-232C port number of PC.

6. Download the firmware

- (1) Click the "Load" button.

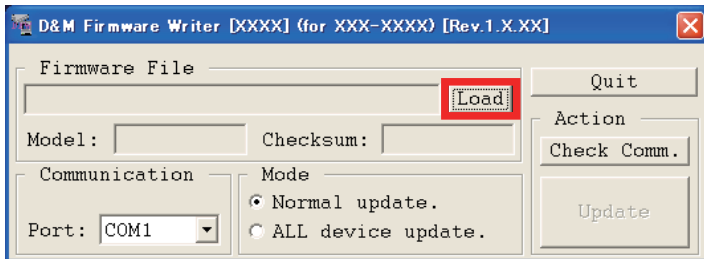

- (2) Download the firmware from the specified download source to PC.

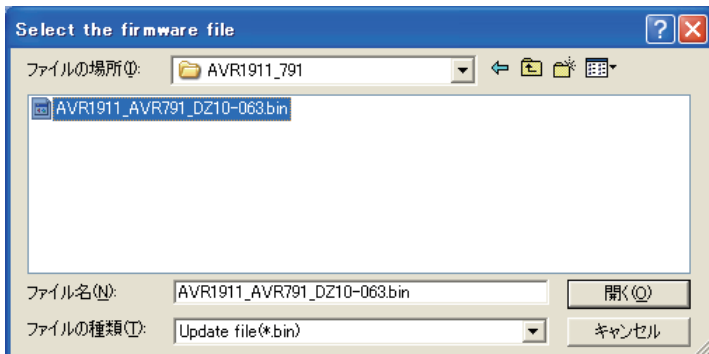

7. Complete the firmware updating

- (1) Click the "Update" button.

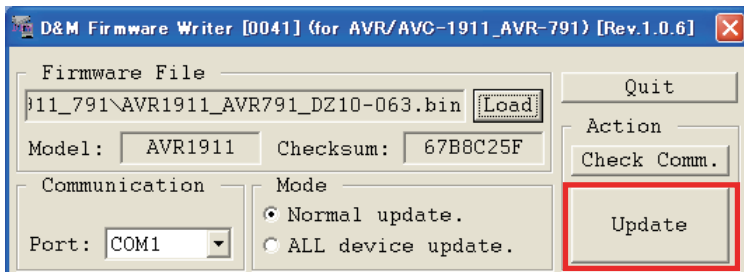

- (2) When writing of the firmware is completed, the power of this unit turns on automatically and you can see the "Update completed" message.

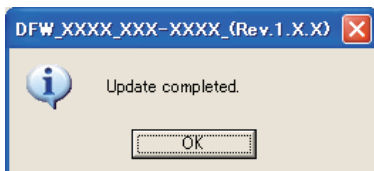

- (3) If you can't complete the firmware update, please retry the firmware update from "3. Turn on the AV receiver/ amplifier".

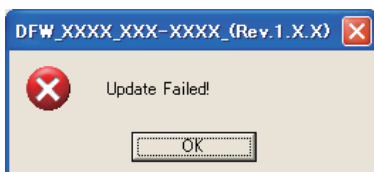

8. Notice:

Please keep the following notice for firmware update.

- (a) Keep the PC environment
- (b) Avoid the communication cable from the electrical noise source.
(e.g. telephone cable, AC line, a fluorescent light)
- (c) Don't remove cable during update.
- (d) Don't turn off the power during update.
- (e) Don't run other PC application during update.
- (f) Stop the resident program on PC (Virus checker and System check utility, etc)
- (g) Stop the screen saver on PC.
- (h) Stop the power save ability on PC.
- (i) In case of laptop PC, Use the AC adaptor.

Confirming the firmware's number after upgraded

After completion of the updating operation, the new version number can be confirmed by starting up the AVR1911 or AVR791 according to the following procedure.

With the following operation, the AVR1911 or AVR791 can be set to the Flash ROM Version-Number Confirmation mode. Turn on power switch while simultaneously pressing "DIMMER" and "STATUS" buttons on the front panel. Every time the "STATUS" button is pressed, version number of the Model, Main, Sub, ... are indicated on the front panel section in the following order.

Depression	Button	Name	Remarks
1	STATUS	Model Name	AVR1911_*****__ AVR791_*****__
2	STATUS	Main CPU	_Main_____:**.**
3	STATUS	-	_Main_FBL_::**.**
4	STATUS	Sub CPU	_Sub_____:**.**
5	STATUS	-	_Sub_FBL_::**.**
6	STATUS	DSP ROM	_DSP_____:**.**
7	STATUS	Audio PLD	A_PLD_:A*****
8	STATUS	USB ROM	_USB_____:**.**
9	STATUS	HD RADIO SDK Ver. (1911E3 only)	_HDSDK_____:**.**
10	STATUS	HD RADIO BBP Ver. (1911E3 only)	_HDBBP:*****.**
11	STATUS	iPod Dock	_Dock_Ver_::**.**

SURROUND MODES AND PARAMETERS

Symbols in the table

- This indicates the audio output channels or surround parameters that can be set.
- ◎ This indicates the audio output channels. The output channels depend on the settings of "Speaker Config."

Surround mode	Channel output					Surround Parameter								
	Front L/R	Center	Surround L/R	Surround Back L/R	Front Height L/R	Subwoofer	Mode	Cinema EQ. *5	DRC *9	D. Comp *10	LFE *11	Delay Time	Effect Lev.	Room Size
PURE DIRECT	○					◎ *3			○	○	○			
DIRECT (2channel)	○					◎ *3			○	○	○			
DIRECT (Multi-channel)	○	◎	◎	◎ *1	◎ *1	◎			○	○	○			
STEREO	○					◎			○	○	○			
MULTI CH IN	○	◎	◎	◎	◎ *2	◎	○ *4		○	○	○			
DOLBY PRO LOGIC IIz	○	◎	◎	◎	◎	◎		○ *6	○	○	○			
DOLBY PRO LOGIC IIx	○	◎	◎	◎		◎		○ *7	○	○	○			
DOLBY PRO LOGIC II	○	◎	◎	◎		◎		○ *6	○	○	○			
DTS NEO:6	○	◎	◎	◎		◎		○ *8	○	○	○			
DOLBY DIGITAL	○	◎	◎	◎	◎ *2	◎		○ *8	○	○	○			
DOLBY DIGITAL Plus	○	◎	◎	◎	◎ *2	◎		○ *8	○	○	○			
DOLBY TrueHD	○	◎	◎	◎	◎ *2	◎		○ *8	○	○	○			
DTS SURROUND	○	◎	◎	◎	◎ *2	◎		○ *8	○	○	○			
DTS 96/24	○	◎	◎	◎	◎ *2	◎		○ *8	○	○	○			
DTS-HD	○	◎	◎	◎	◎ *2	◎		○ *8	○	○	○			
DTS Express	○	◎	◎	◎	◎ *2	◎		○ *8	○	○	○			
MULTI CH STEREO	○	◎	◎	◎	◎ *2	◎		○ *8	○	○	○			○
ROCK ARENA	○	◎	◎	◎	◎ *2	◎			○	○	○			○
JAZZ CLUB	○	◎	◎	◎	◎ *2	◎			○	○	○			○
MONO MOVIE	○	◎	◎	◎	◎ *2	◎			○	○	○			○
VIDEO GAME	○	◎	◎	◎	◎ *2	◎			○	○	○			○
MATRIX	○	◎	◎	◎	◎ *2	◎			○	○	○			○
VIRTUAL	○	◎	◎	◎	◎ *2	◎ *3			○	○	○			○

*1 A signal for each channel contained in an input signal is output as audio.

*2 If "Surround Parameter" – "Front Height" is set to "ON", sound is output from the front height speakers.

*3 Only when "Subwoofer Mode" is set to "LFE+Main", sound is output from the subwoofer.

*4 If this surround mode is selected, only the "Height" mode setting is available for "Surround Parameter" – "Mode".

*5 For HD Audio whose sampling frequency of an input signal is more than 96kHz, this surround parameter cannot be set.

*6 This item can be selected when "Surround Parameter" – "Mode" is set to "Cinema".

*7 This item can be selected when "Surround Parameter" – "Mode" is set to "Cinema" or "Pro Logic".

*8 This item cannot be set when "Surround Parameter" – "S.Back" is set to "PLIIx Music".

*9 This item can be selected when a Dolby TrueHD signal is played.

*10 This item can be selected when a Dolby Digital or DTS signal is played.

*11 This item can be selected when a Dolby Digital or DTS signal or DVD-Audio is played.

Surround mode	Surround Parameter										Audyssey Settings * 20			RESTORER * 19			
	AFDM * 12	S.Back	Front Height * 13	Height Gain	Subwoofer	PRO LOGIC II/IIx Music mode only			NEO6 Music mode only	Tone * 15	MultEQ®	Dynamic EQ® * 17	Dynamic Volume™ * 18				
						Panorama	Dimension	Center Width							Center Image		
PURE DIRECT					<input type="radio"/> * 3												
DIRECT (2 channel)					<input type="radio"/> * 3												
DIRECT (Multi-channel)																	
STEREO																	
MULTI CH IN	<input type="radio"/>	<input type="radio"/>	<input type="radio"/>	<input type="radio"/> * 14						<input type="radio"/>	<input type="radio"/>	<input type="radio"/>	<input type="radio"/>	<input type="radio"/>	<input type="radio"/>	<input type="radio"/>	<input type="radio"/>
DOLBY PRO LOGIC IIz		<input type="radio"/>	<input type="radio"/>	<input type="radio"/>													<input type="radio"/>
DOLBY PRO LOGIC IIx		<input type="radio"/>	<input type="radio"/>	<input type="radio"/>	<input type="radio"/>	<input type="radio"/>	<input type="radio"/>	<input type="radio"/>									<input type="radio"/>
DOLBY PRO LOGIC II		<input type="radio"/>	<input type="radio"/>	<input type="radio"/>	<input type="radio"/>	<input type="radio"/>	<input type="radio"/>	<input type="radio"/>									<input type="radio"/>
DTS NEO6		<input type="radio"/>	<input type="radio"/>	<input type="radio"/>	<input type="radio"/>	<input type="radio"/>	<input type="radio"/>	<input type="radio"/>									<input type="radio"/>
DOLBY DIGITAL	<input type="radio"/>	<input type="radio"/>	<input type="radio"/>	<input type="radio"/>					<input type="radio"/>	<input type="radio"/>	<input type="radio"/>	<input type="radio"/>	<input type="radio"/>	<input type="radio"/>	<input type="radio"/>	<input type="radio"/>	<input type="radio"/>
DOLBY DIGITAL Plus	<input type="radio"/>	<input type="radio"/>	<input type="radio"/>	<input type="radio"/>					<input type="radio"/>	<input type="radio"/>	<input type="radio"/>	<input type="radio"/>	<input type="radio"/>	<input type="radio"/>	<input type="radio"/>	<input type="radio"/>	<input type="radio"/>
DOLBY TrueHD	<input type="radio"/>	<input type="radio"/>	<input type="radio"/>	<input type="radio"/>					<input type="radio"/>	<input type="radio"/>	<input type="radio"/>	<input type="radio"/>	<input type="radio"/>	<input type="radio"/>	<input type="radio"/>	<input type="radio"/>	<input type="radio"/>
DTS SURROUND	<input type="radio"/>	<input type="radio"/>	<input type="radio"/>	<input type="radio"/>					<input type="radio"/>	<input type="radio"/>	<input type="radio"/>	<input type="radio"/>	<input type="radio"/>	<input type="radio"/>	<input type="radio"/>	<input type="radio"/>	<input type="radio"/>
DTS 96/24	<input type="radio"/>	<input type="radio"/>	<input type="radio"/>	<input type="radio"/>					<input type="radio"/>	<input type="radio"/>	<input type="radio"/>	<input type="radio"/>	<input type="radio"/>	<input type="radio"/>	<input type="radio"/>	<input type="radio"/>	<input type="radio"/>
DTS-HD	<input type="radio"/>	<input type="radio"/>	<input type="radio"/>	<input type="radio"/>					<input type="radio"/>	<input type="radio"/>	<input type="radio"/>	<input type="radio"/>	<input type="radio"/>	<input type="radio"/>	<input type="radio"/>	<input type="radio"/>	<input type="radio"/>
DTS Express	<input type="radio"/>	<input type="radio"/>	<input type="radio"/>	<input type="radio"/>					<input type="radio"/>	<input type="radio"/>	<input type="radio"/>	<input type="radio"/>	<input type="radio"/>	<input type="radio"/>	<input type="radio"/>	<input type="radio"/>	<input type="radio"/>
MULTI CH STEREO		<input type="radio"/>	<input type="radio"/>	<input type="radio"/>					<input type="radio"/>	<input type="radio"/>	<input type="radio"/>	<input type="radio"/>	<input type="radio"/>	<input type="radio"/>	<input type="radio"/>	<input type="radio"/>	<input type="radio"/>
ROCK ARENA		<input type="radio"/>	<input type="radio"/>	<input type="radio"/>					<input type="radio"/>	<input type="radio"/>	<input type="radio"/>	<input type="radio"/>	<input type="radio"/>	<input type="radio"/>	<input type="radio"/>	<input type="radio"/>	<input type="radio"/>
JAZZ CLUB		<input type="radio"/>	<input type="radio"/>	<input type="radio"/>					<input type="radio"/>	<input type="radio"/>	<input type="radio"/>	<input type="radio"/>	<input type="radio"/>	<input type="radio"/>	<input type="radio"/>	<input type="radio"/>	<input type="radio"/>
MONO MOVIE		<input type="radio"/>	<input type="radio"/>	<input type="radio"/>					<input type="radio"/>	<input type="radio"/>	<input type="radio"/>	<input type="radio"/>	<input type="radio"/>	<input type="radio"/>	<input type="radio"/>	<input type="radio"/>	<input type="radio"/>
VIDEO GAME		<input type="radio"/>	<input type="radio"/>	<input type="radio"/>					<input type="radio"/>	<input type="radio"/>	<input type="radio"/>	<input type="radio"/>	<input type="radio"/>	<input type="radio"/>	<input type="radio"/>	<input type="radio"/>	<input type="radio"/>
MATRIX		<input type="radio"/>	<input type="radio"/>	<input type="radio"/>					<input type="radio"/>	<input type="radio"/>	<input type="radio"/>	<input type="radio"/>	<input type="radio"/>	<input type="radio"/>	<input type="radio"/>	<input type="radio"/>	<input type="radio"/>
VIRTUAL		<input type="radio"/>	<input type="radio"/>	<input type="radio"/>					<input type="radio"/>	<input type="radio"/>	<input type="radio"/>	<input type="radio"/>	<input type="radio"/>	<input type="radio"/>	<input type="radio"/>	<input type="radio"/>	<input type="radio"/>

* 3 Only when "Subwoofer Mode" is set to "LFE+Main", sound is output from the subwoofer.

* 12 This item can be selected when a Dolby Digital or DTS or DVD-Audio signal is played.

* 13 If "Speaker Config." is set to "None", this item cannot be selected.

* 14 This item can be selected when "Surround Parameter" is set to "ON".

* 15 This item cannot be set when "Dynamic EQ" is set to "ON".

* 16 In this surround mode, bass is +6 dB, and treble is +4 dB. (Default)

* 17 This item cannot be set when "MultEQ" is set to "OFF" or "Manual".

* 18 This item cannot be set when "Dynamic EQ" is set to "OFF".

* 19 This item can be set when the input signal is analog, PCM 48 kHz or 44.1 kHz.

* 20 For HD Audio whose sampling frequency of an input signal is more than 96 kHz, this sound parameter cannot be set.

Symbols in the table

- This indicates the default surround mode.
- ◎ This indicates the surround mode that is fixed when "AFDM" is set to "ON".
- This indicates the selectable surround mode.

Surround mode	NOTE	Input signal types and formats															
		ANALOG	PCM		DTS-HD		DTS EXPRESS	DTS ES DSCRT (With Flag)	DTS ES MTRX (With Flag)	DTS (5.1ch)	DTS 96/24	DOLBY		DOLBY DIGITAL			
		LINEAR PCM (multi ch)	LINEAR PCM (2ch)	DTS-HD Master Audio	DTS-HD High Resolution Audio							DOLBY TrueHD	DOLBY DIGITAL Plus	DOLBY DIGITAL EX (With no Flag)	DOLBY DIGITAL (5.1/5/4ch)	DOLBY DIGITAL (4/3ch)	DOLBY DIGITAL (2ch)
DTS SURROUND																	
DTS-HD MSTR				●													
DTS-HD HI RES	*1 *3				●												
DTS ES DSCRT6.1	*1 *3					◎											
DTS ES MTRX6.1	*1 *3					◎											
DTS SURROUND									●								
DTS 96/24										●							
DTS (-HD) + PLIIx CINEMA	*2 *3																
DTS (-HD) + PLIIx MUSIC	*1 *3																
DTS (-HD) + PLIIz	*4																
DTS EXPRESS																	
DTS (-HD) + NEO6	*1 *3							●									
DTS NEO6 CINEMA																	○ ○
DTS NEO6 MUSIC																	○ ○
DOLBY SURROUND																	
DOLBY TrueHD												●					
DOLBY DIGITAL+																	
DOLBY DIGITAL EX	*1 *3																
DOLBY (D+)(HD)+EX	*1 *3																
DOLBY DIGITAL																	
DOLBY (D)(D+)(HD)+PLIIx CINEMA	*2 *3																
DOLBY (D)(D+)(HD)+PLIIx MUSIC	*1 *3																
DOLBY (D)(D+)(HD)+PLIIz	*4																
DOLBY PRO LOGIC Ix CINEMA	*1 *3																
DOLBY PRO LOGIC Ix MUSIC	*1 *3																
DOLBY PRO LOGIC Ix GAME	*1 *3																
DOLBY PRO LOGIC IIz	*4																
DOLBY PRO LOGIC II CINEMA																	○ ○ ○ ○ ○ ○ ○ ○
DOLBY PRO LOGIC II MUSIC																	○ ○ ○ ○ ○ ○ ○ ○
DOLBY PRO LOGIC II GAME																	○ ○ ○ ○ ○ ○ ○ ○
DOLBY PRO LOGIC																	○ ○ ○ ○ ○ ○ ○ ○

*1 If "Speaker Config." - "S Back" is set to "None", this surround mode cannot be selected.

*2 If "Speaker Config." - "S Back" is set to "1sp" or "None", this surround mode cannot be selected.

*3 This surround mode can be selected when "Amp Assign" is set to "Normal".

*4 If "Speaker Config." - "Front Height" is set to "None", this surround mode cannot be selected.

Surround mode	NOTE	Input signal types and formats															
		ANALOG	PCM		DTS-HD		DTS				DOLBY		DOLBY DIGITAL				
			LINEAR PCM (multi ch)	LINEAR PCM (2ch)	DTS-HD Master Audio	DTS-HD High Resolution Audio	DTS EXPRESS	DTS ES DSCRT (With Flag)	DTS ES MTRX (With Flag)	DTS (5.1ch)	DTS 96/24	DOLBY TrueHD	DOLBY DIGITAL Plus	DOLBY DIGITAL EX (With no Flag)	DOLBY DIGITAL (5.1/5/4ch)	DOLBY DIGITAL (4/3ch)	DOLBY DIGITAL (2ch)
MULTI CH IN																	
MULTI CH IN + PLIIx CINEMA	* 2 * 3	●															
MULTI CH IN + PLIIx MUSIC	* 1 * 3	○															
MULTI CH IN + PLIIz	* 4	○															
MULTI CH IN + Dolby EX	* 1 * 3	○															
MULTI CH IN 7.1	* 3	●															
DIRECT																	
DIRECT		○															
PURE DIRECT		○															
PURE DIRECT		○															
DSP SIMULATION																	
MULTI CH STEREO		○															
ROCK ARENA		○															
JAZZ CLUB		○															
MONO MOVIE		○															
VIDEO GAME		○															
MATRIX		○															
VIRTUAL		○															
STEREO		●															

* 1 If "Speaker Config." - "S.Back" is set to "None", this surround mode cannot be selected.

* 2 If "Speaker Config." - "S.Back" is set to "1sp" or "None", this surround mode cannot be selected.

* 3 This surround mode can be selected when "Amp Assign" is set to "Normal".

* 4 If "Speaker Config." - "Front Height" is set to "None", this surround mode cannot be selected.

ADJUSTMENT

Audio Section

Idling Current

Required measurement equipment: DC Voltmeter

1. Preparation

- (1) Avoid direct blow from an air conditioner or an electric fan, and adjust the unit at normal room temperature 15 °C ~ 30 °C (59 °F ~ 86 °F).
- (2) Presetting
 - POWER (Power source switch) STANDBY
 - SPEAKER (Speaker terminal) No load
(Do not connect speaker, dummy resistor, etc.)

2. Adjustment

- (1) Remove top cover and set VR401, VR402, VR403, VR404, VR405, VR406, VR407 on 7CH AMP UNIT at fully counterclockwise (⤵) position.
- (2) Connect DC Voltmeter to test points (FRONT-Lch: TP401, FRONT-Rch: TP402, CENTER ch: TP403, SURROUND-Lch: TP404, SURROUND-Rch: TP405, SURROUND-BACK Lch: TP406, SURROUND-BACK Rch: TP407).
- (3) Connect power cord to AC Line, and turn power switch "ON".
- (4) Presetting.
 - MASTER VOLUME : "---" counterclockwise (⤵ min.)
 - SPEAKER (Speaker terminal) : No load
(Do not connect speaker, dummy resistor, etc.)
 - MODE : MCH STEREO
 - FUNCTION : DVD
- (5) Within 2 minutes after the power on, turn VR401 clockwise (⤴) to adjust the TEST POINT voltage to 1.5 mV ± 0.5 mV DC.
- (6) After 10 minutes from the preset above, turn VR401 to set the voltage to 2.0 mV ± 0.5 mV DC.
- (7) Adjust the Variable Resistors of other channels in the same way.

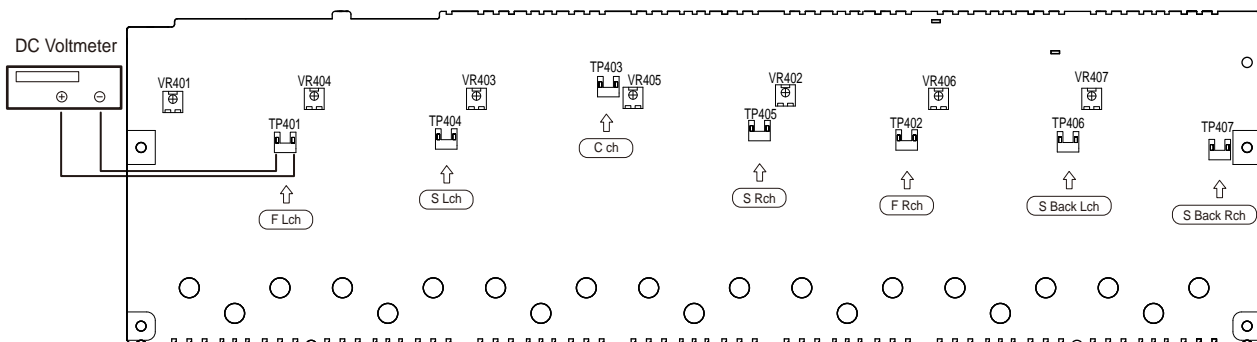
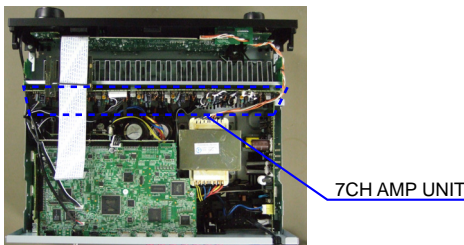

TROUBLE SHOOTING

1. POWER

1.1. Power not turn on

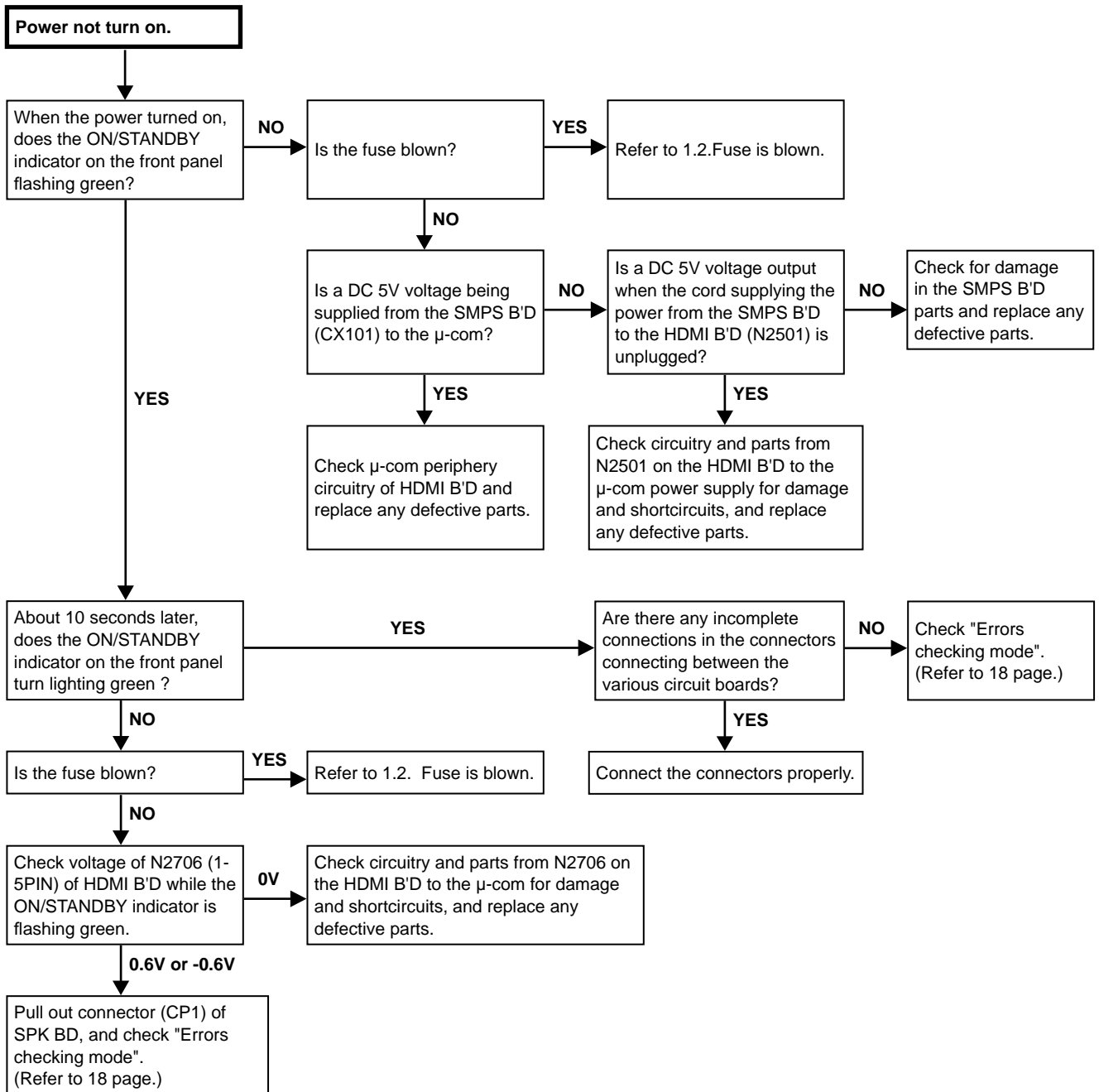

1.2. Fuse is blown

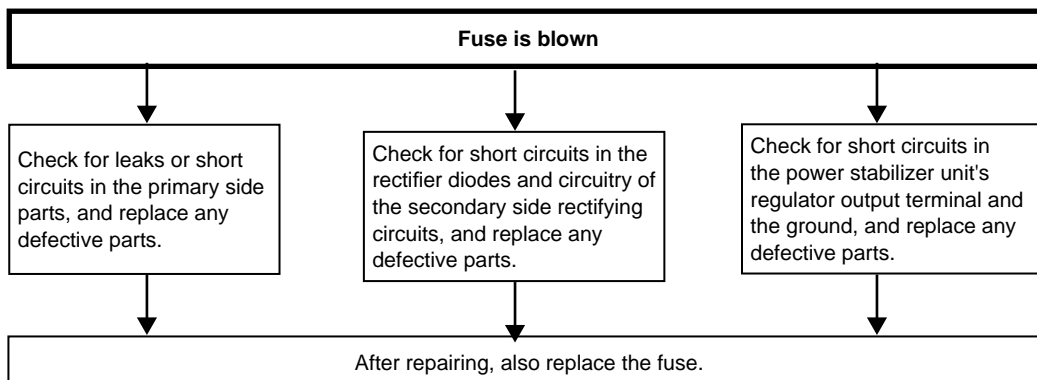

2. Analog video

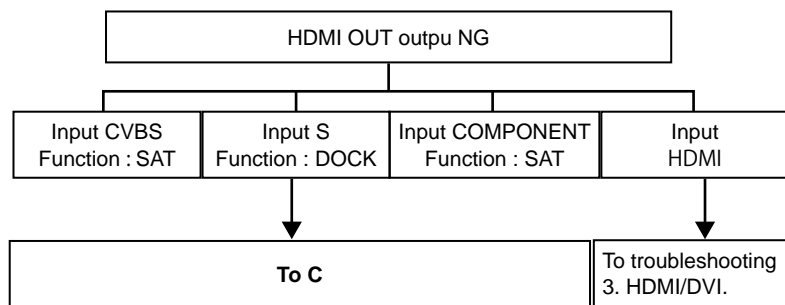
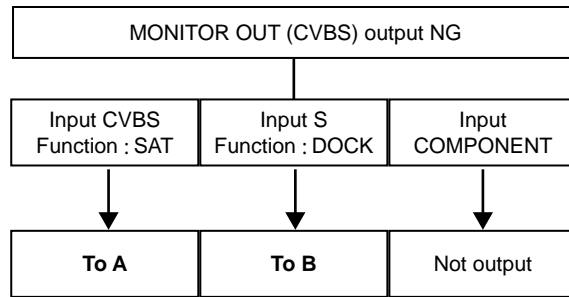

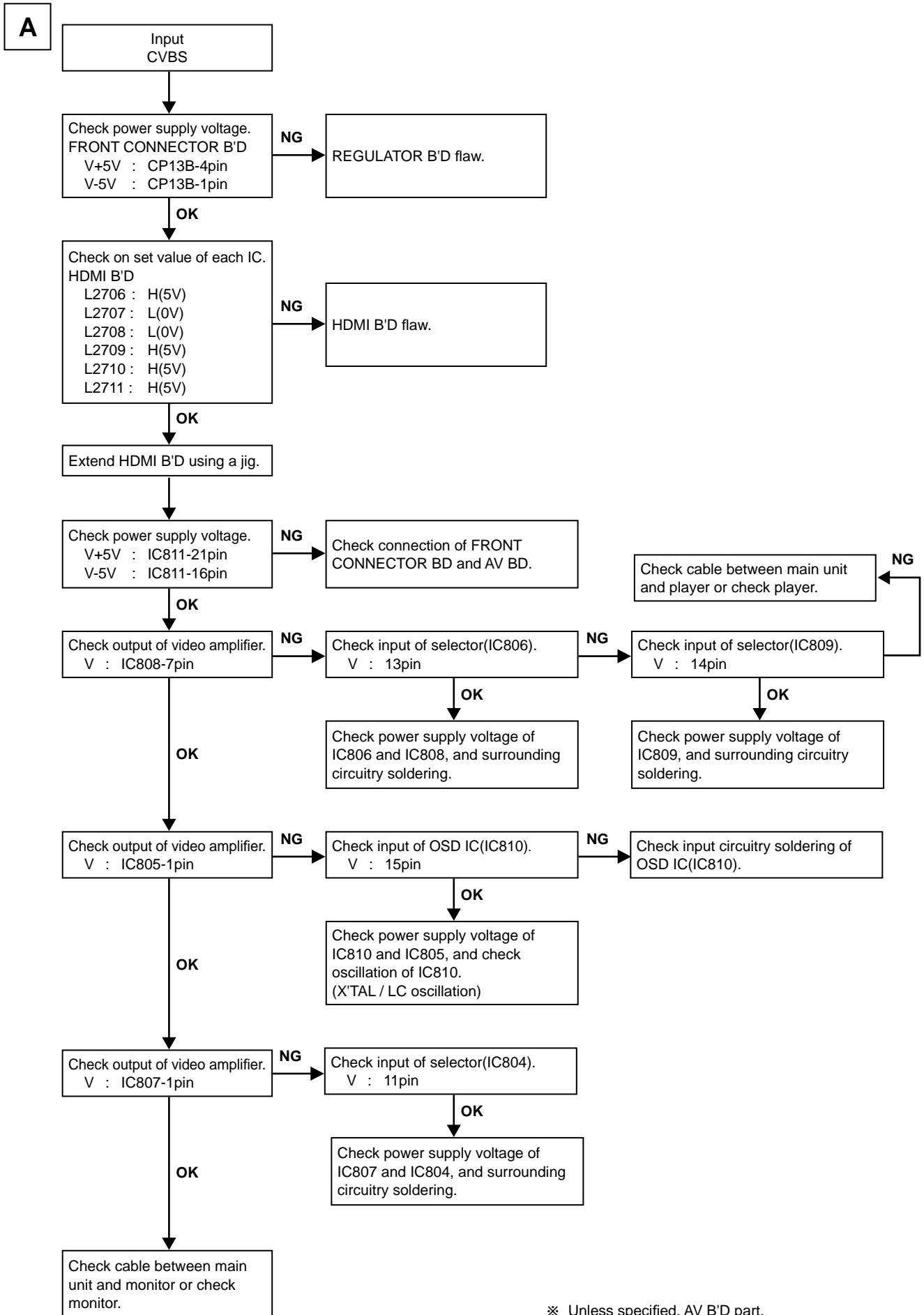

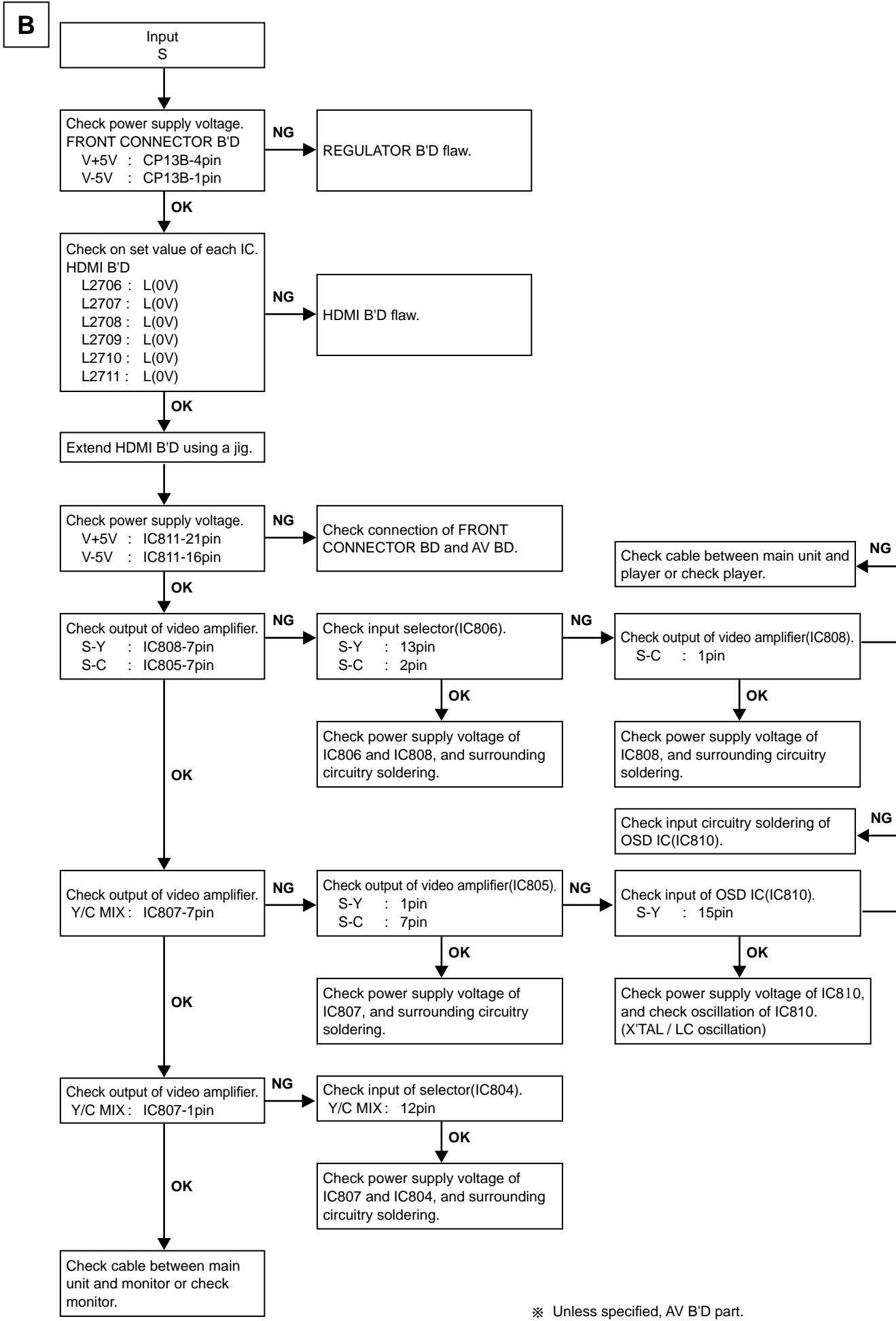

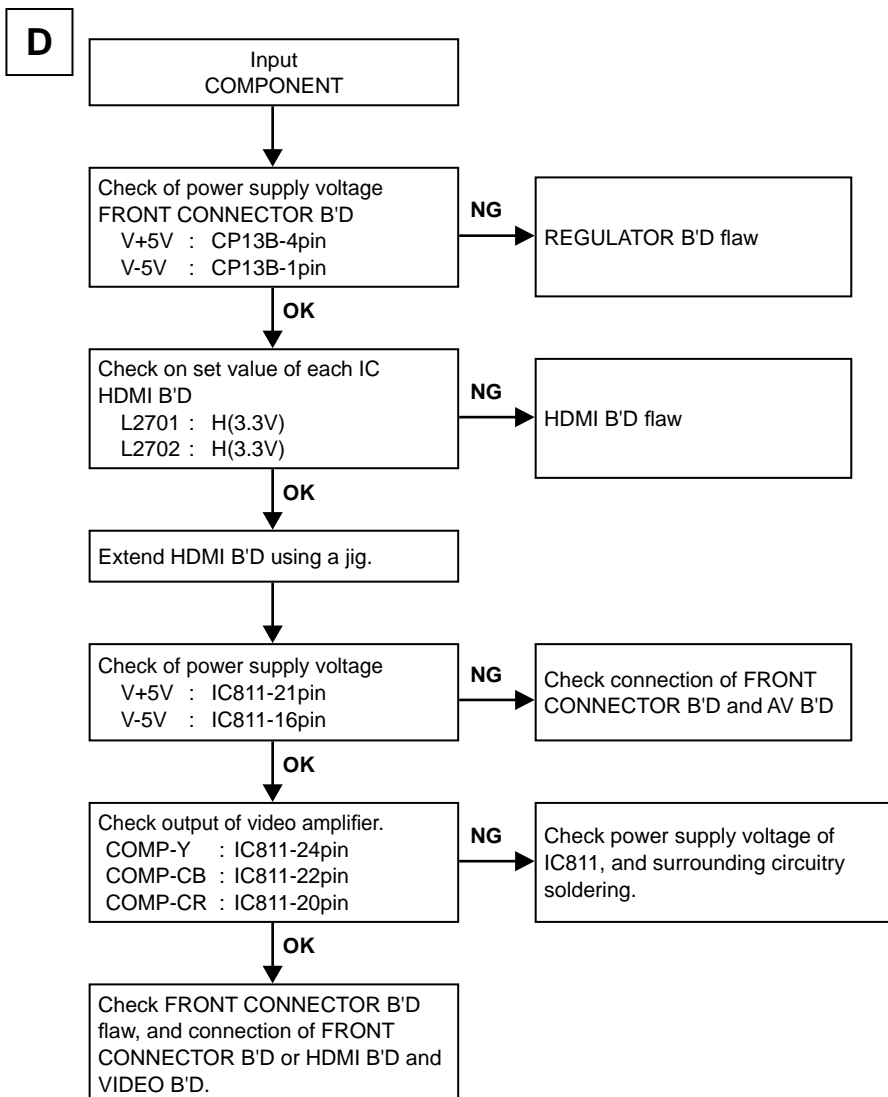
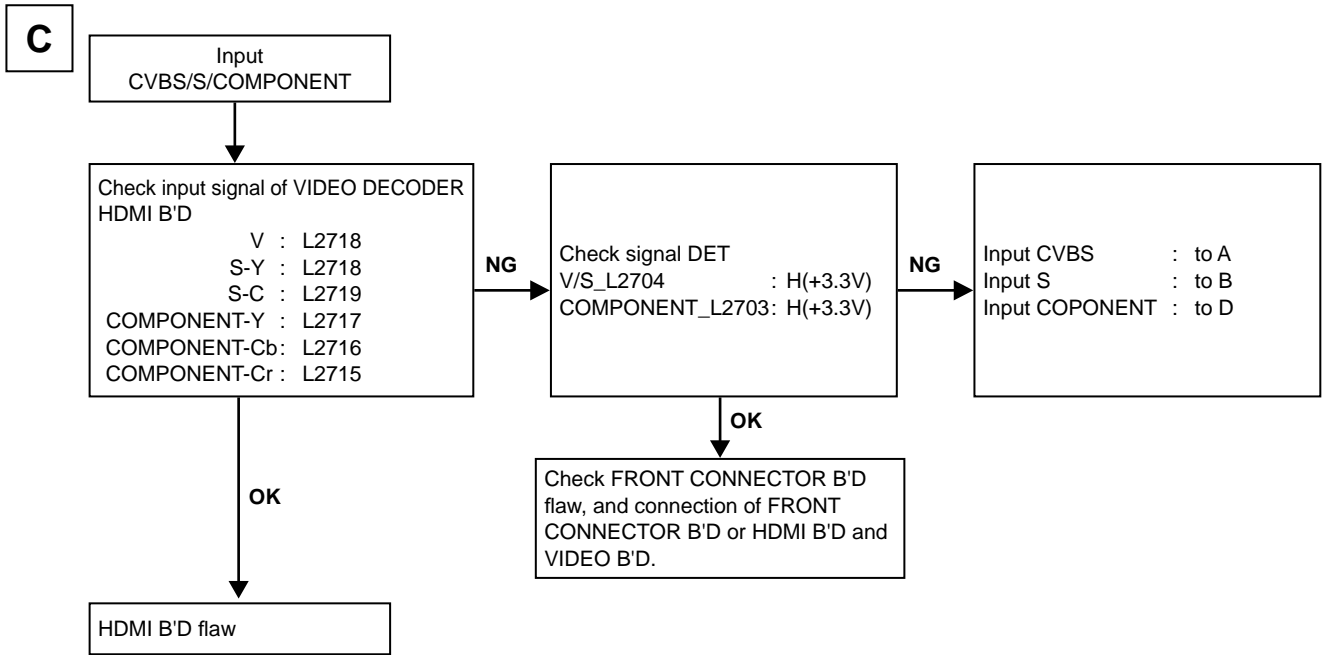

※ Unless specified, AV B'D part.

3. HDMI/DVI

3.1. No picture or sound is output

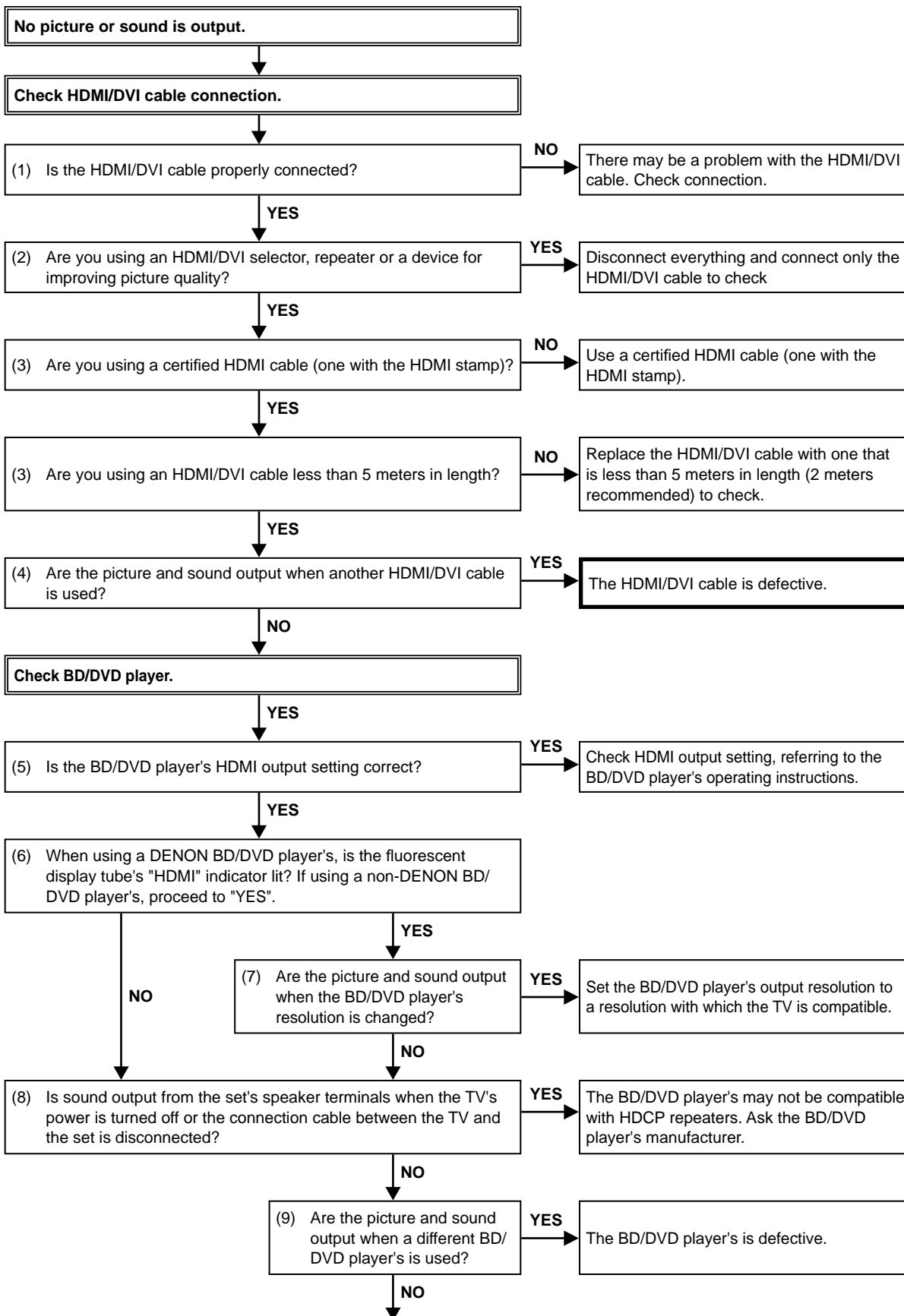

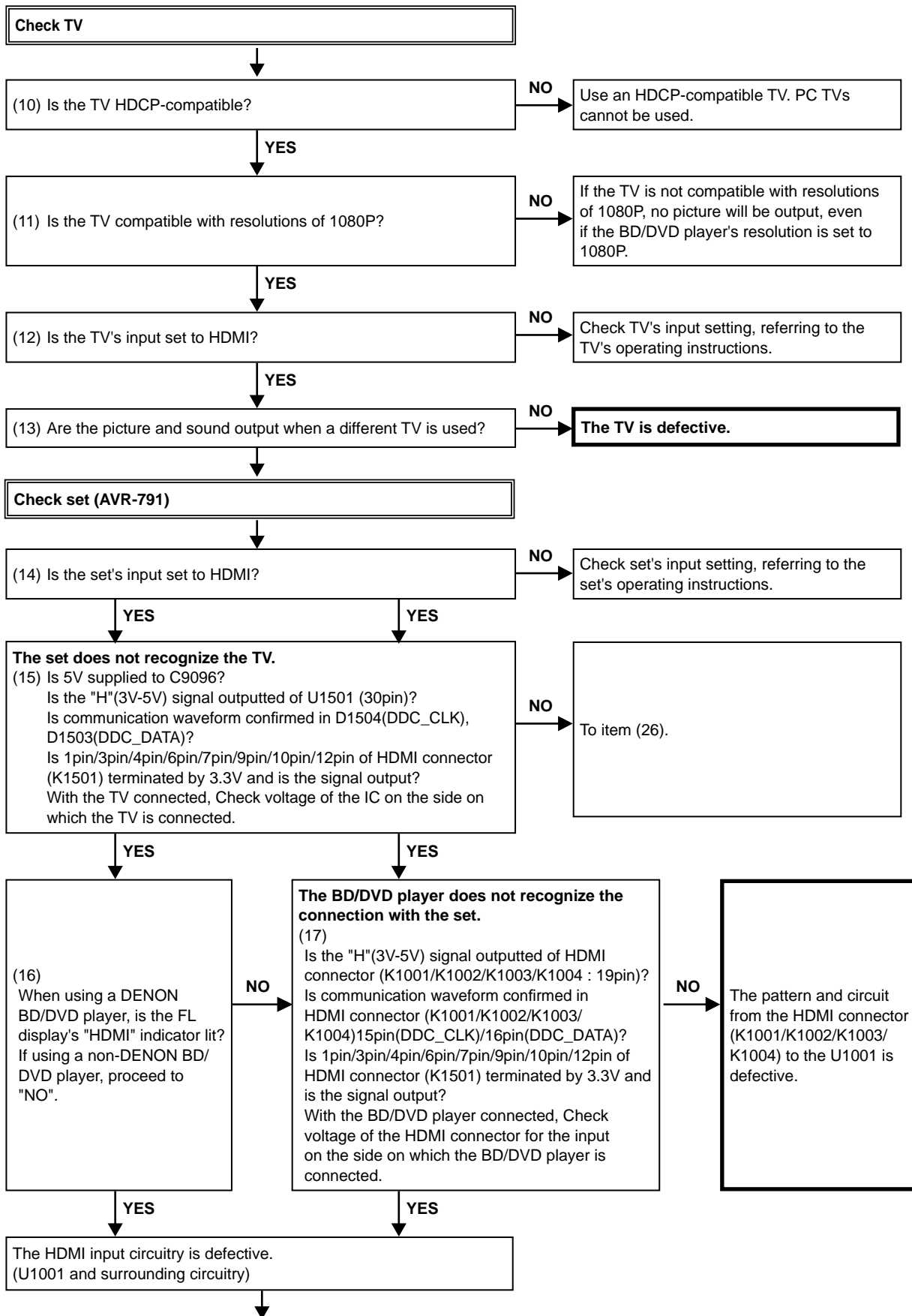

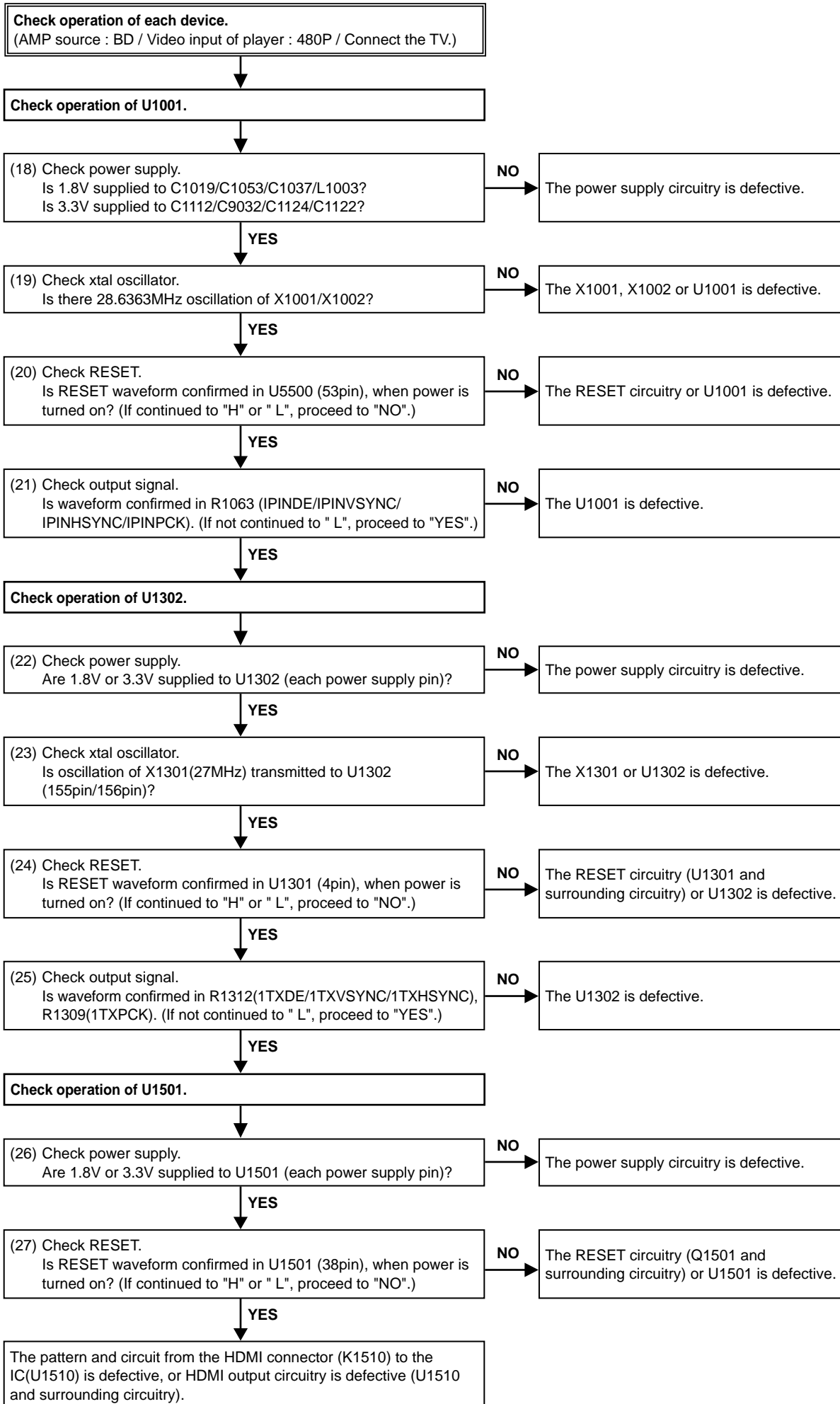

3.2. HDMI test point and waveforms

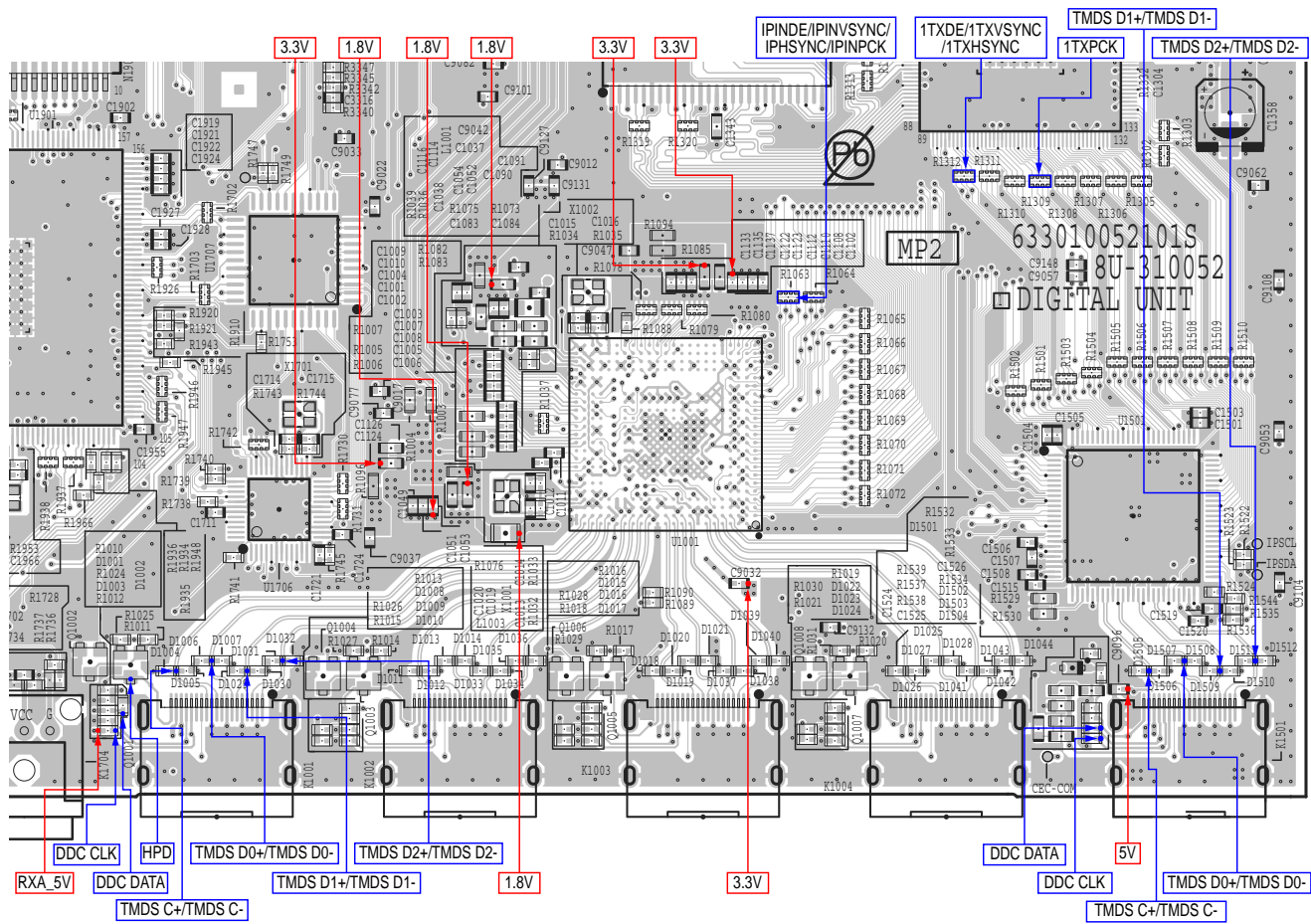
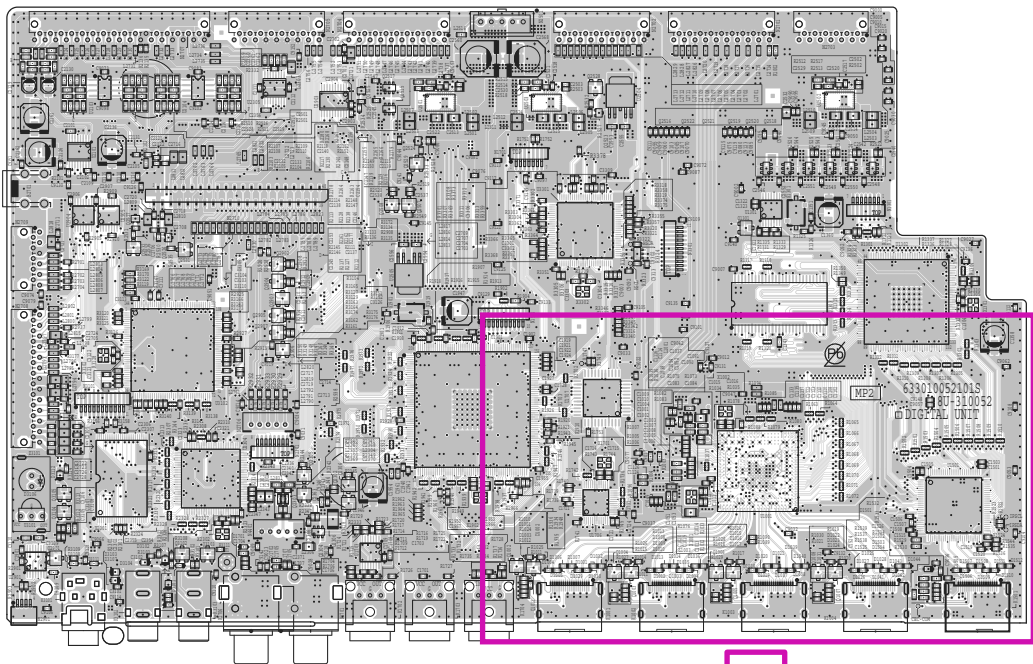

DDC_CLK/DDC_DATA/TMDS(1,3,4,6,7,9,10,12pin) : Check item (15),(17)

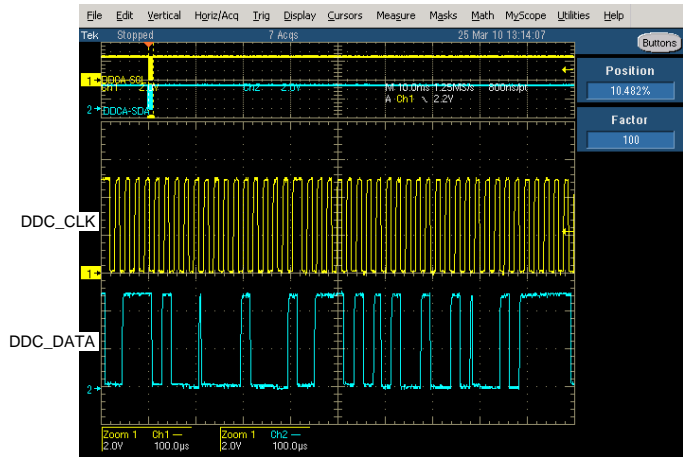
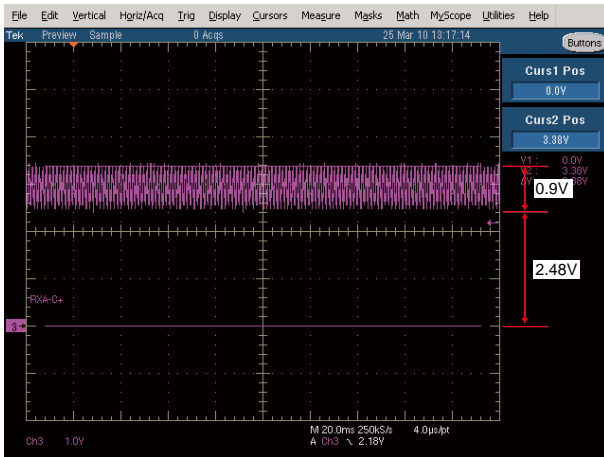

IPINDE/IPINVSNC/IPINHSNC/IPINPCK : Check item (21)

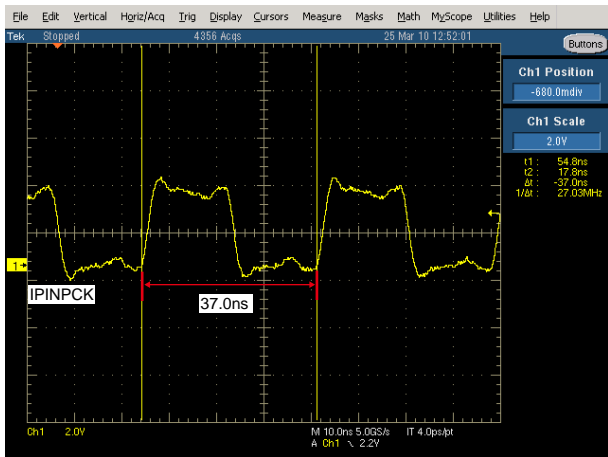
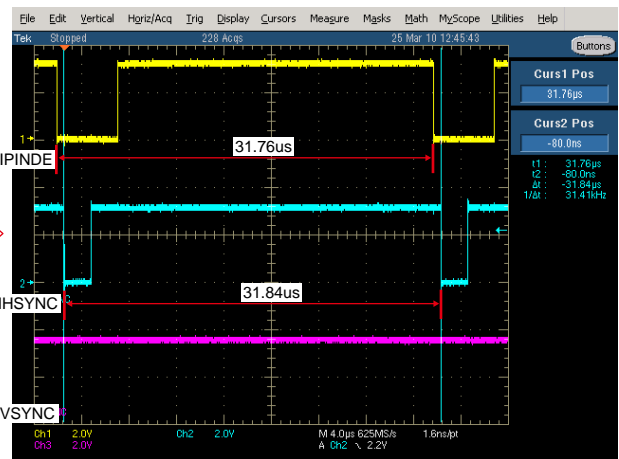
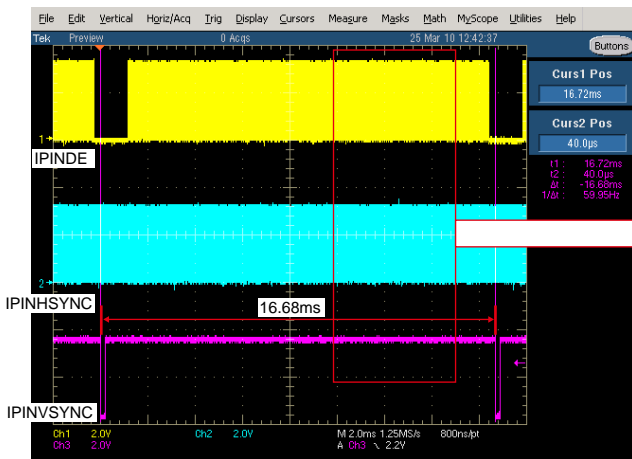

1TXDE/1TXVSYNC/1TXHSYNC/1TXPCK : Check item (25)

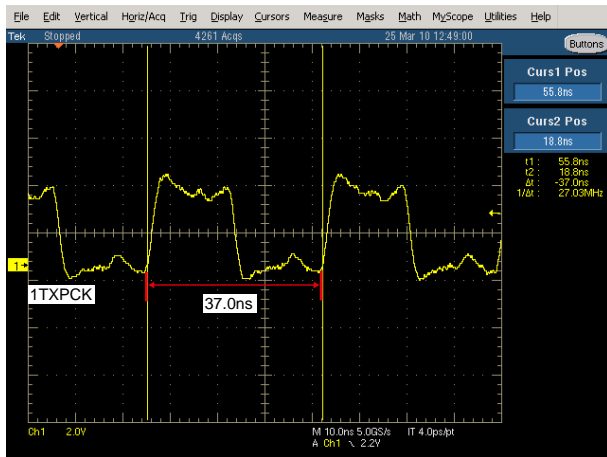
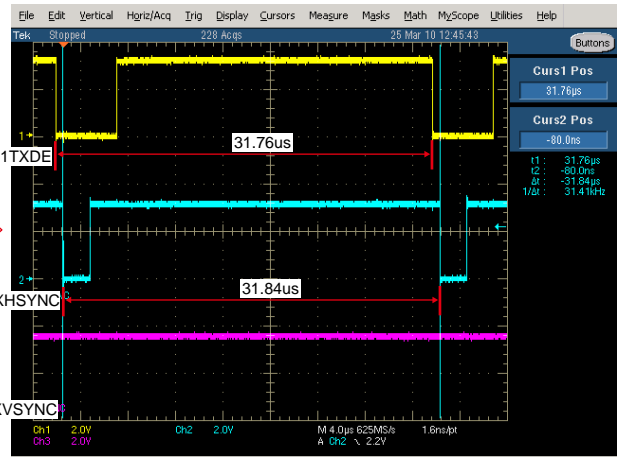
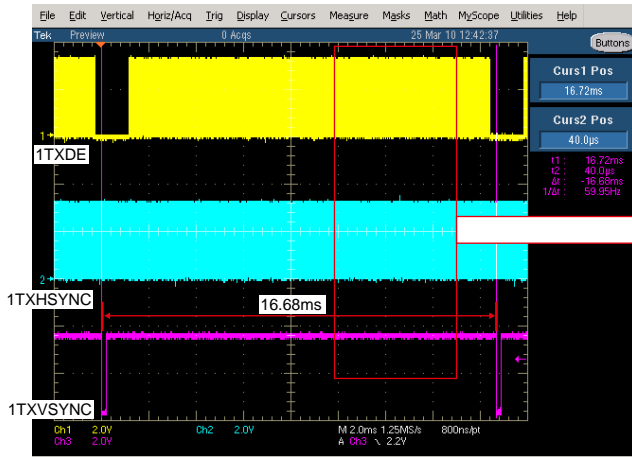

4. AUDIO

4.1. AUDIO CHECK

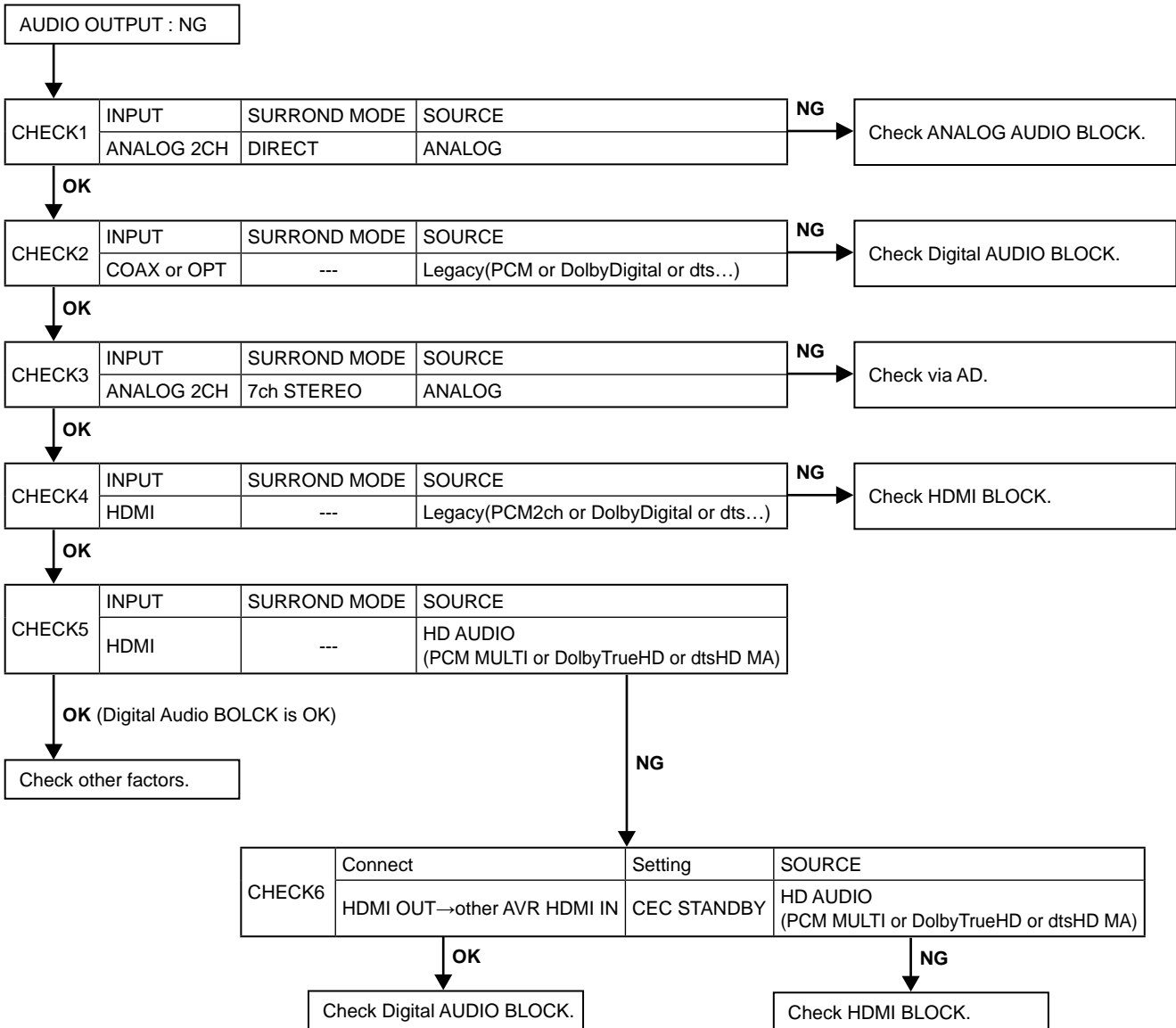

4.2. Power AMP (7CH AMP B'D)

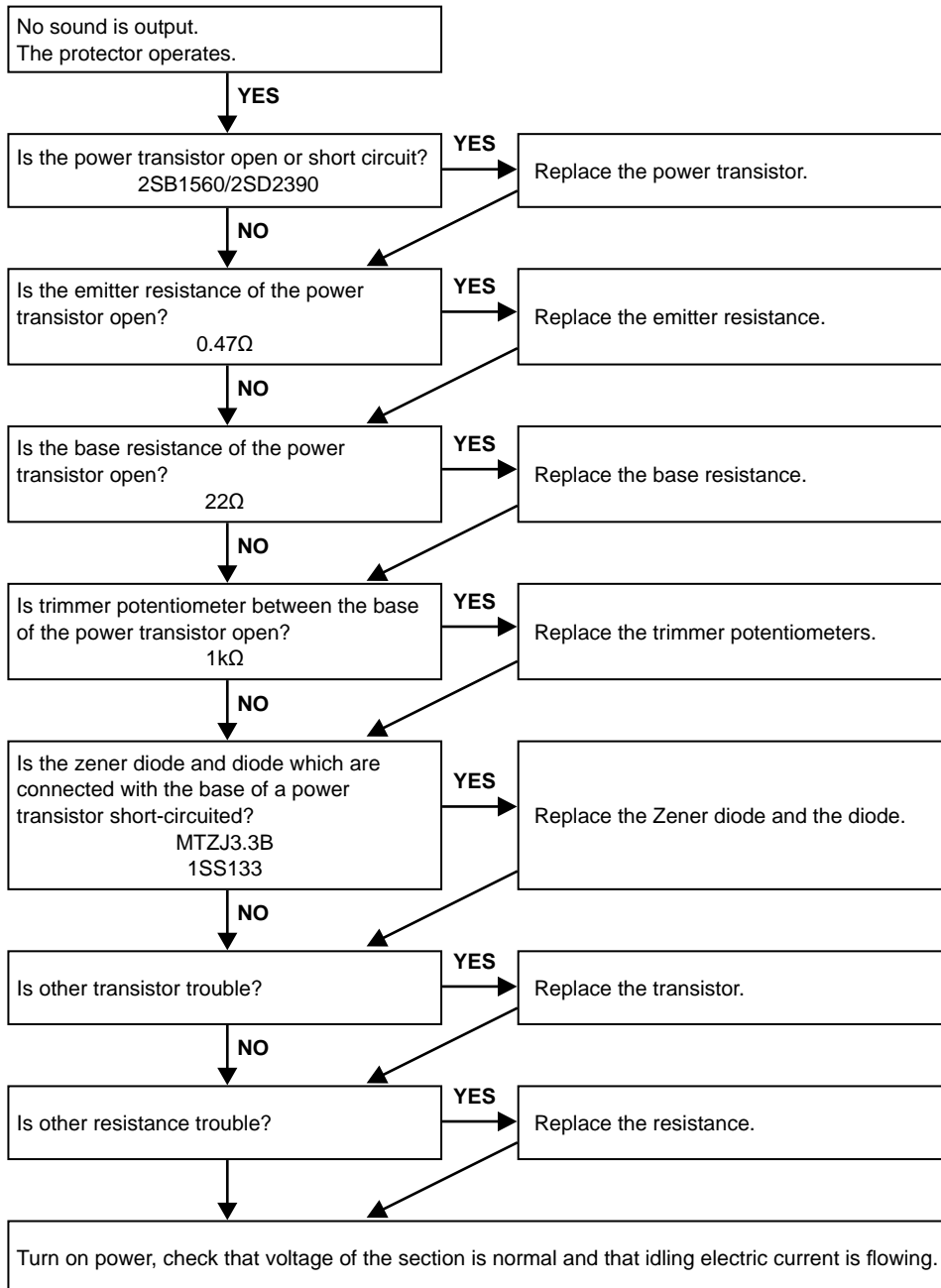

4.3. Analog audio

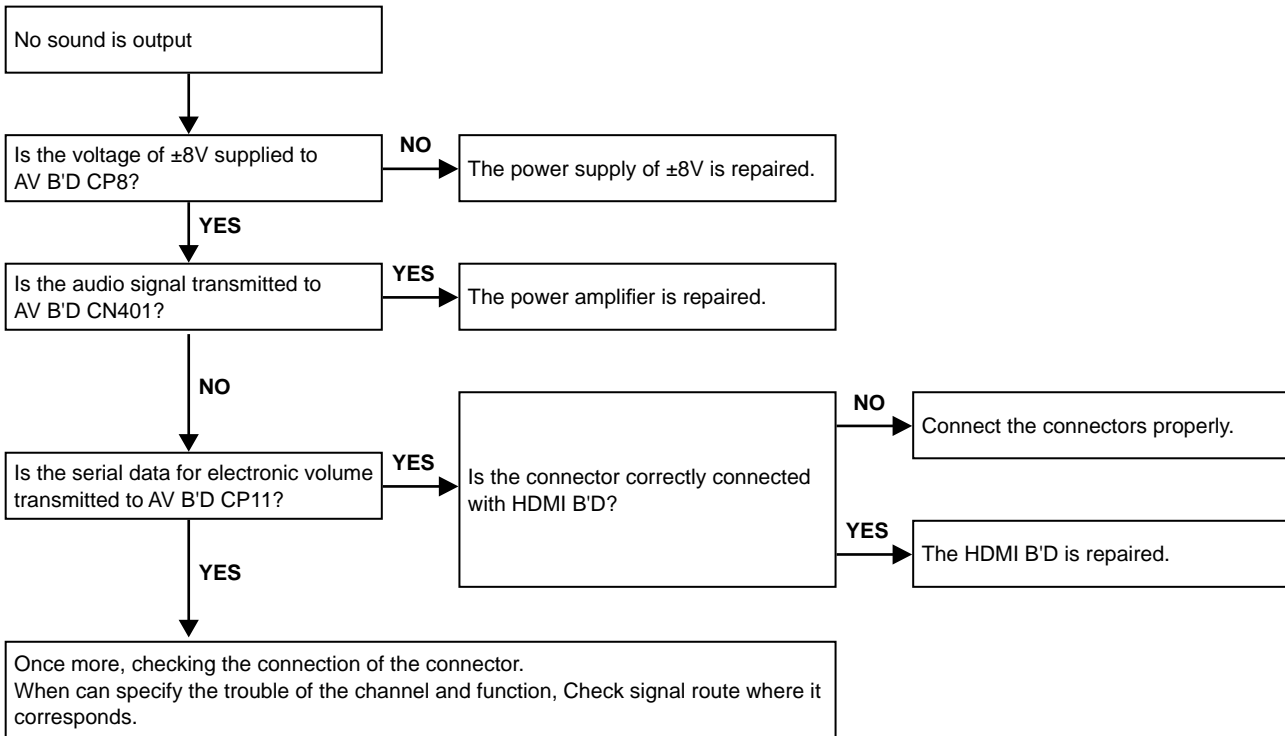

CLOCK FLOW & WAVE FORM IN DIGITAL BLOCK

Wave form

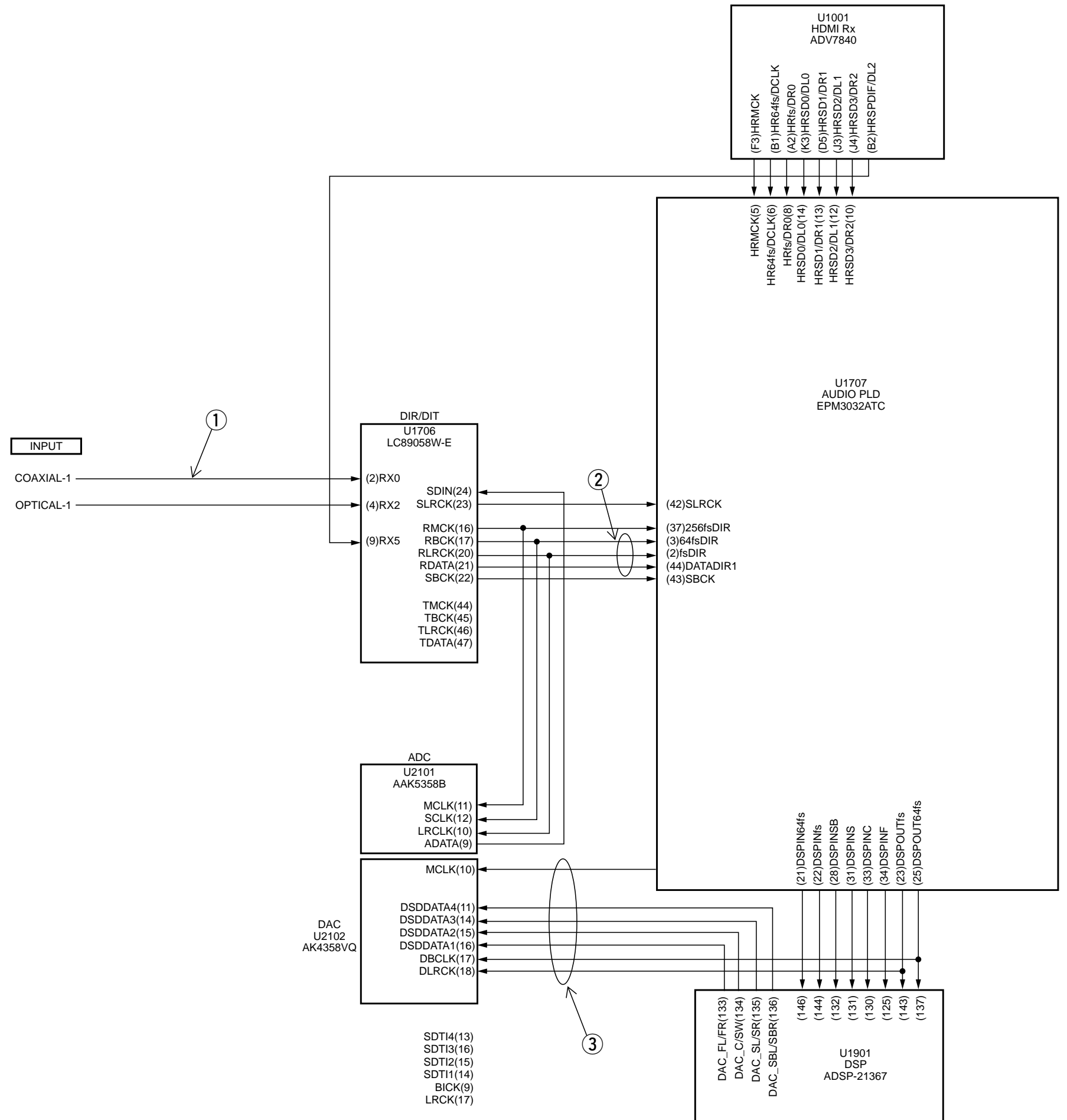
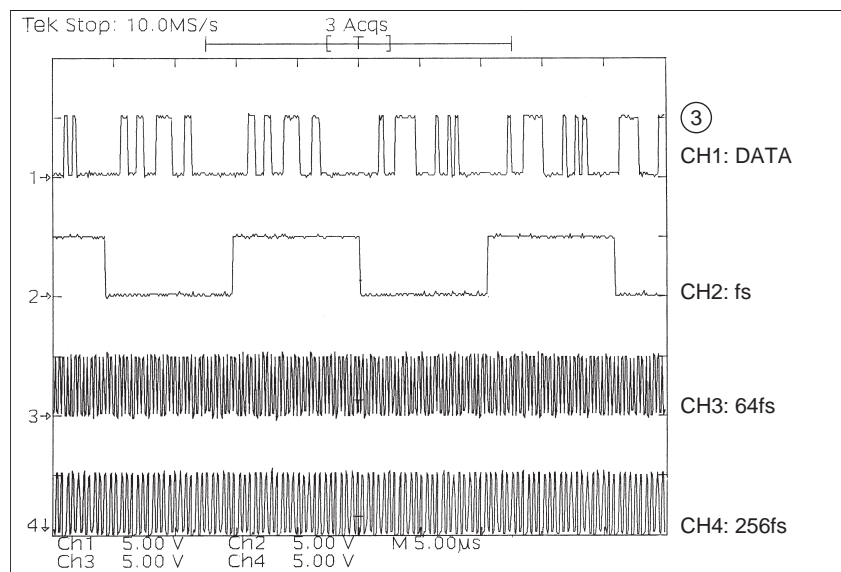
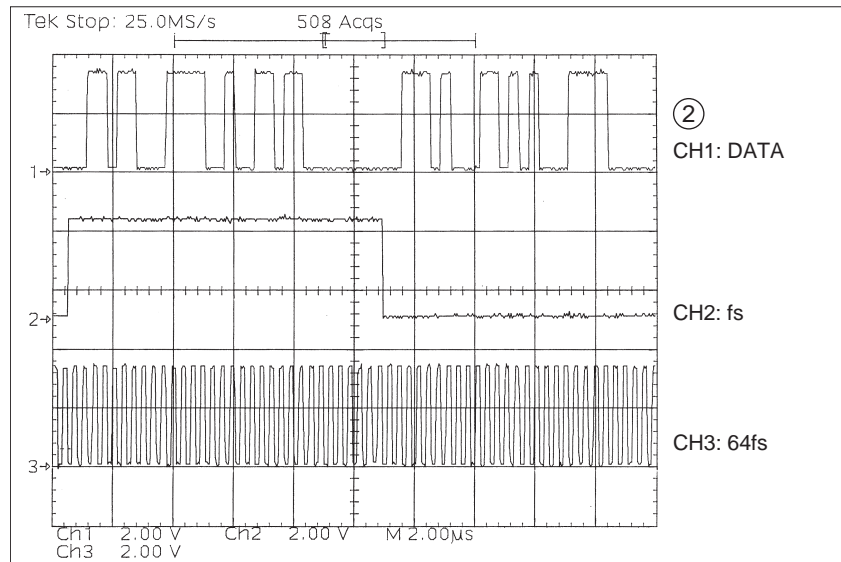
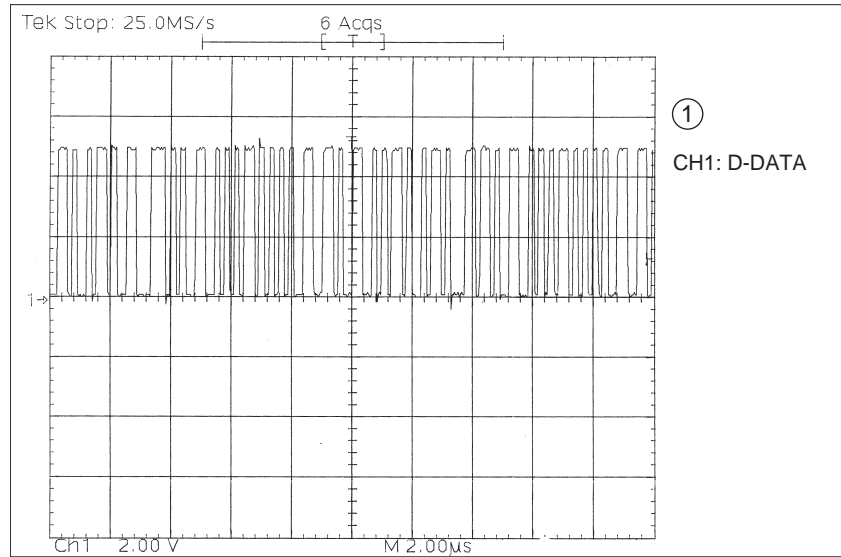

BLOCK DIAGRAM

AUDIO BLOCK DIAGRAM

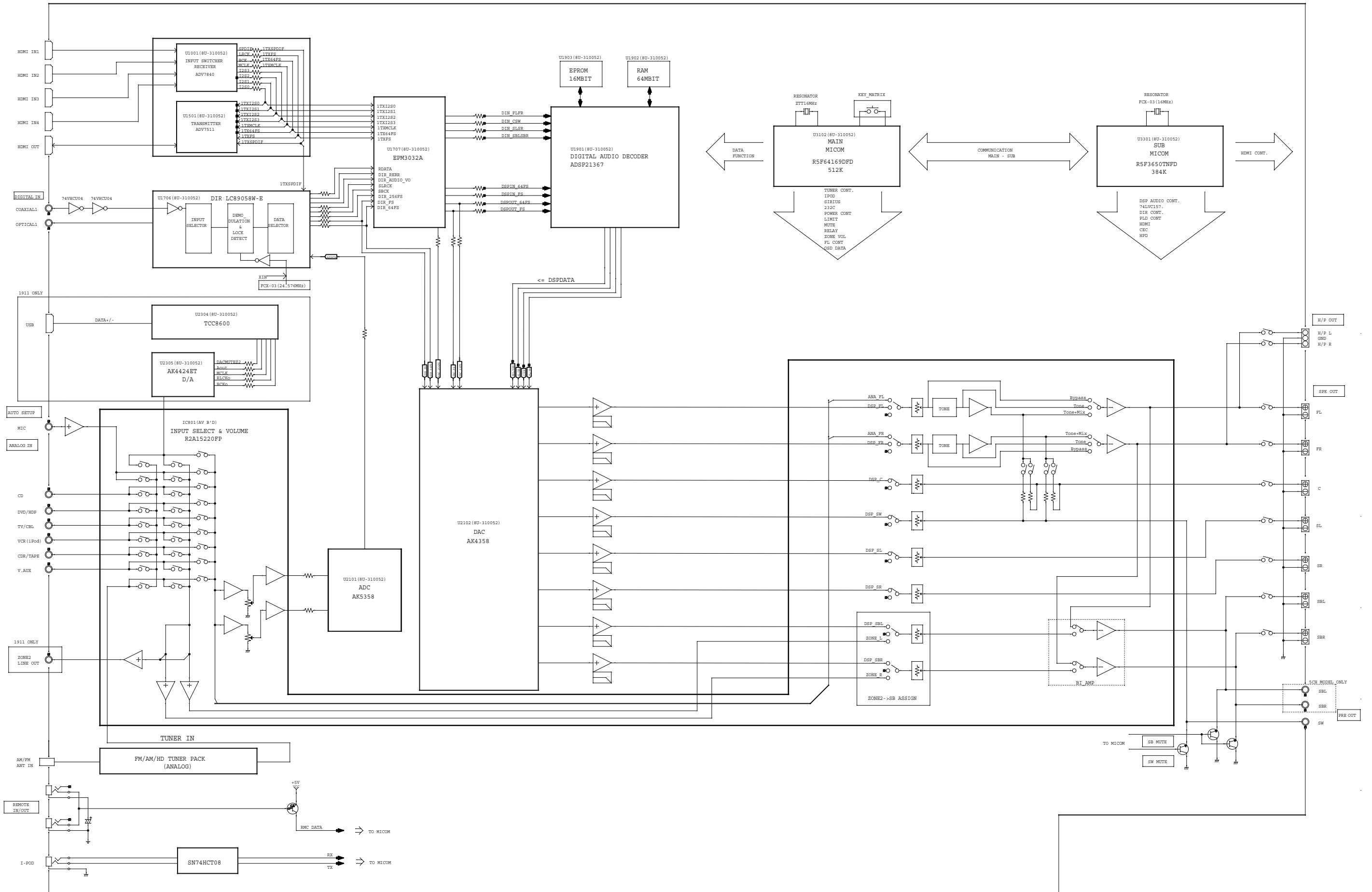

VIDEO BLOCK DIAGRAM

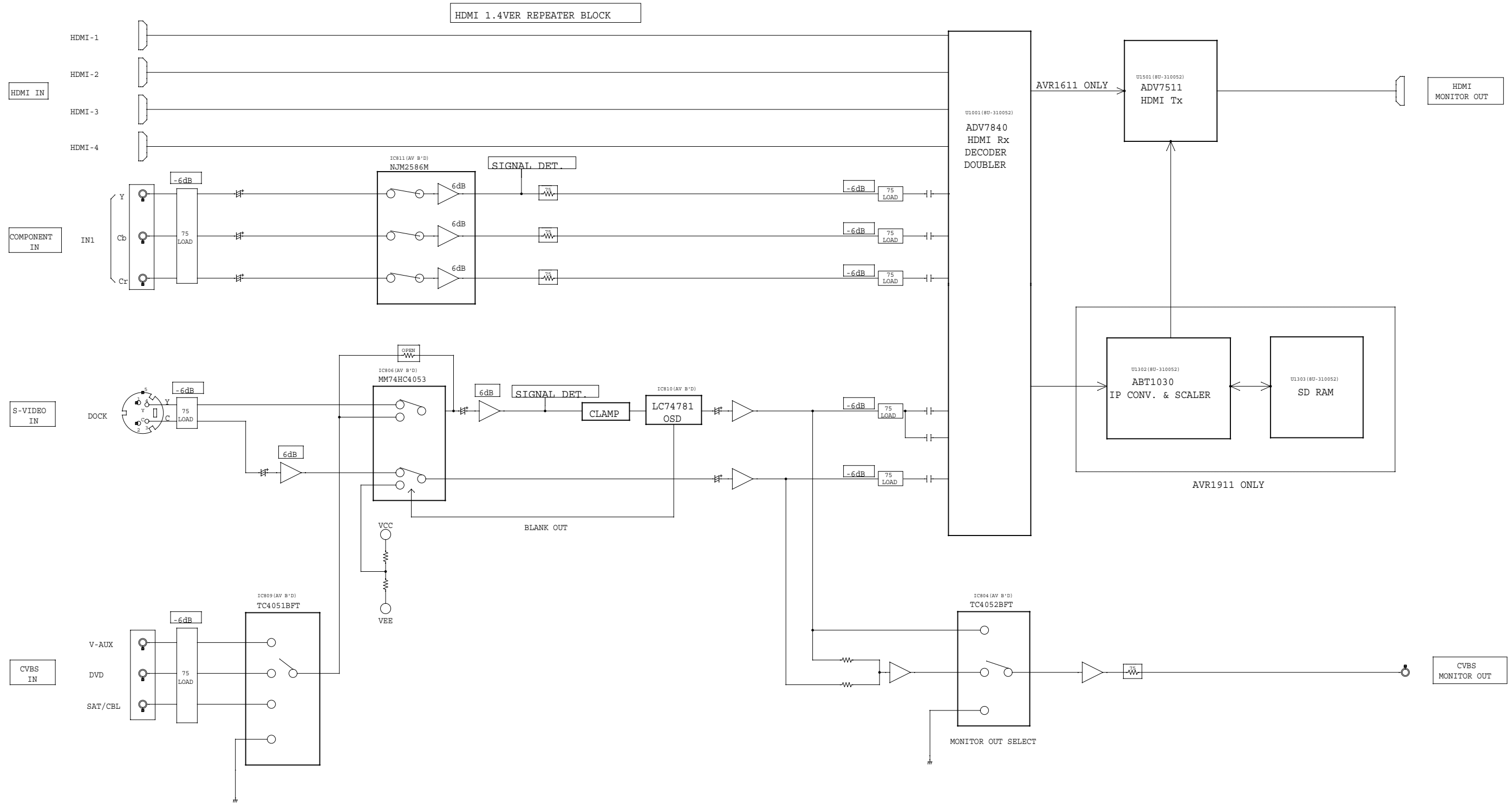

VCC BLOCK DIAGRAM

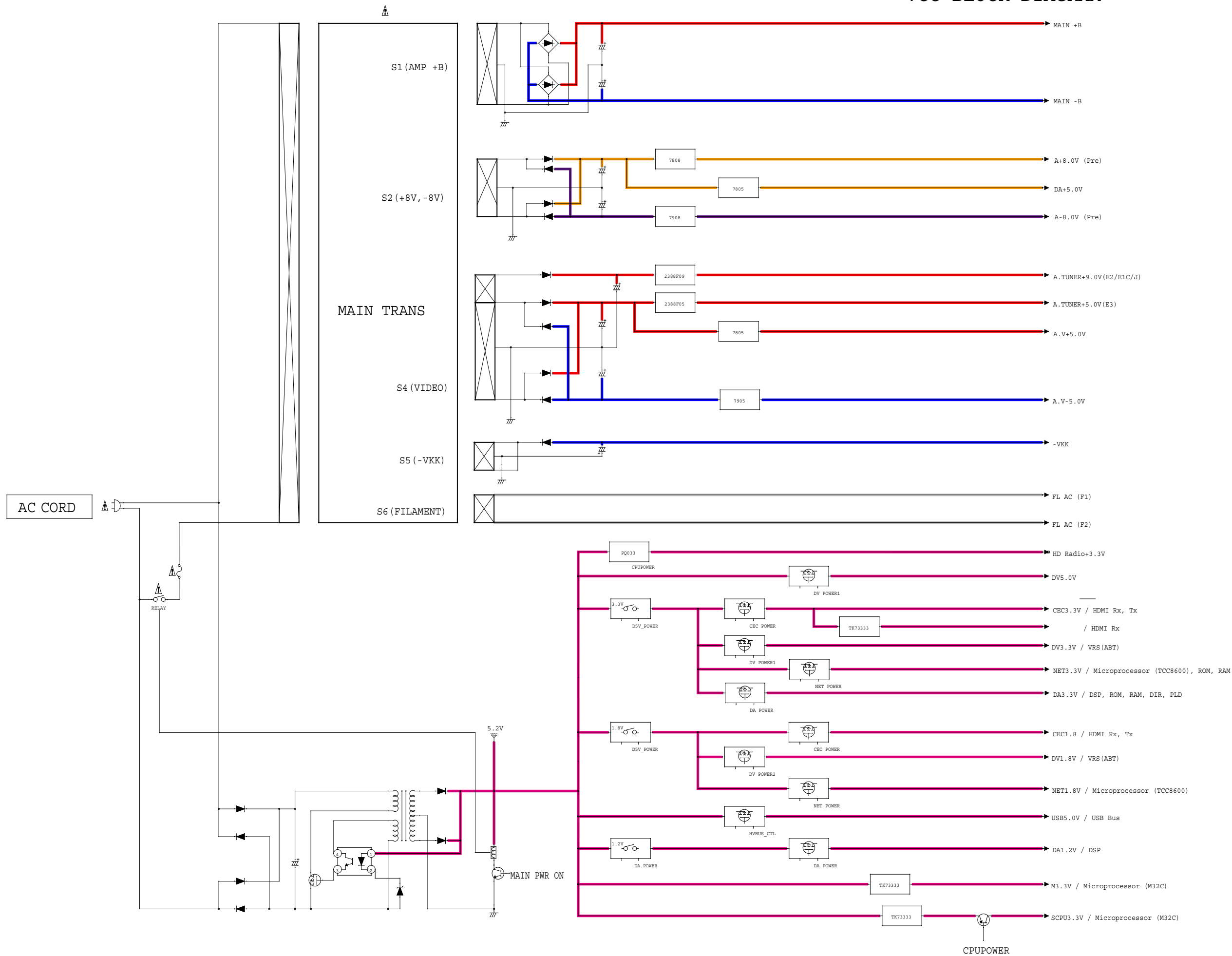

LA LEVEL DIAGRAM

LEVEL DIAGRAM FRONT ch

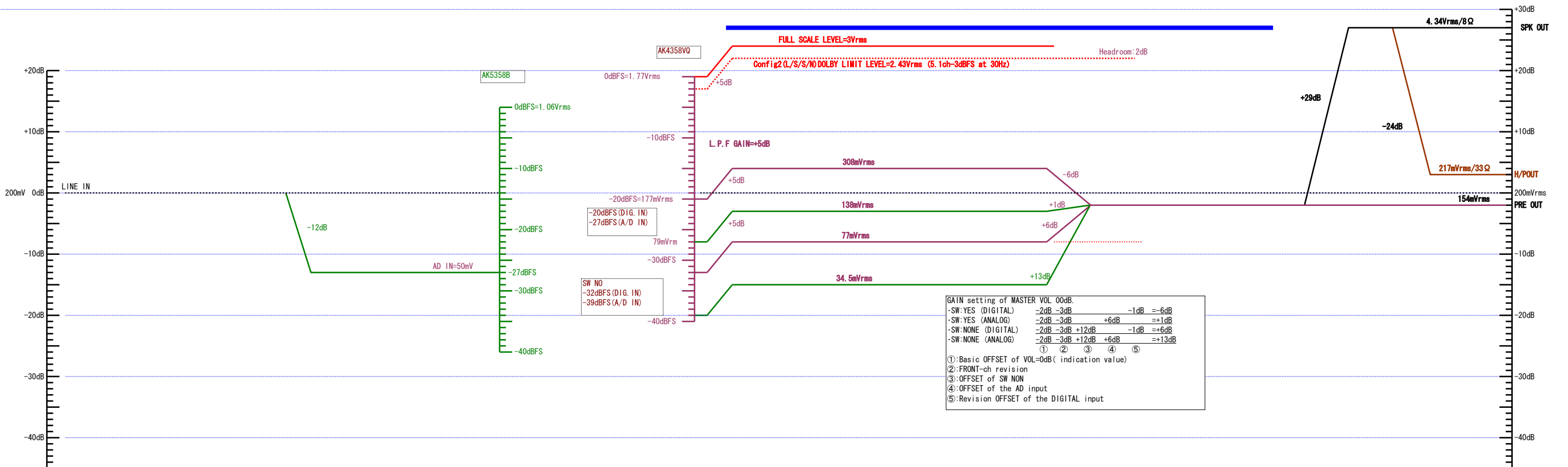
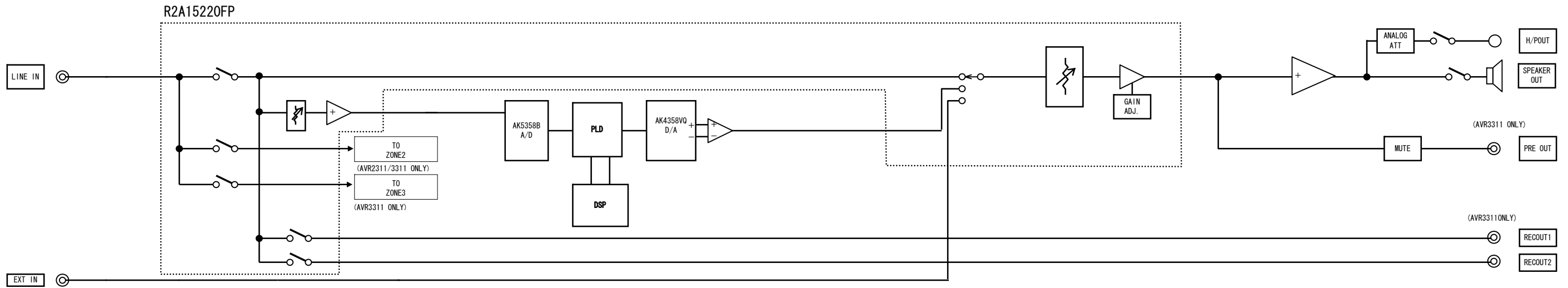

LEVEL DIAGRAM
CENTER ch

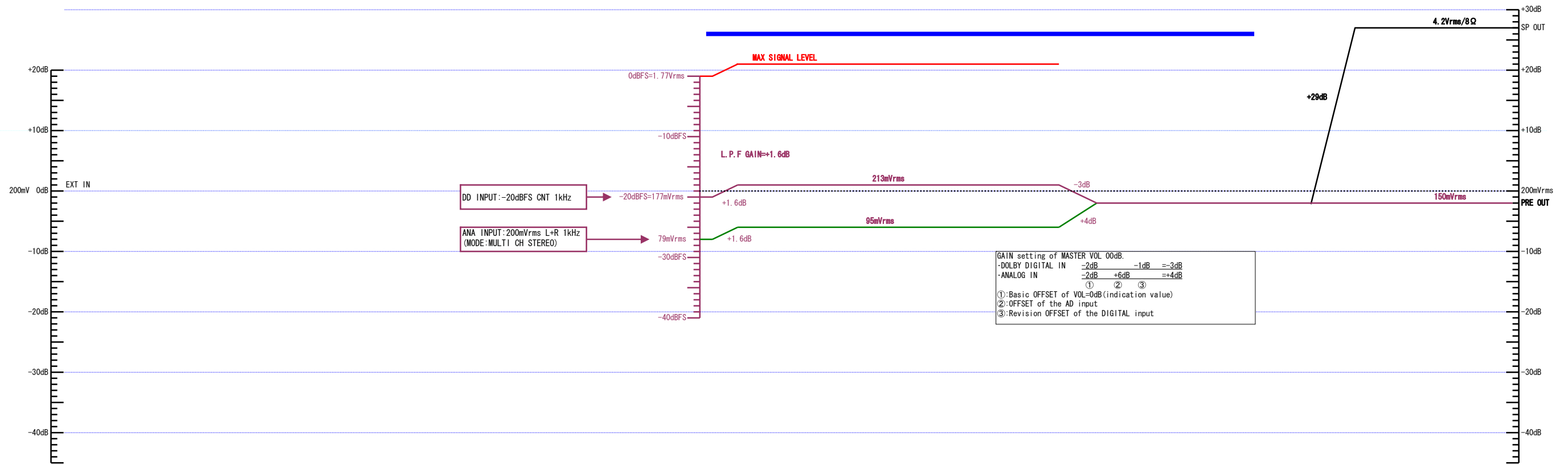
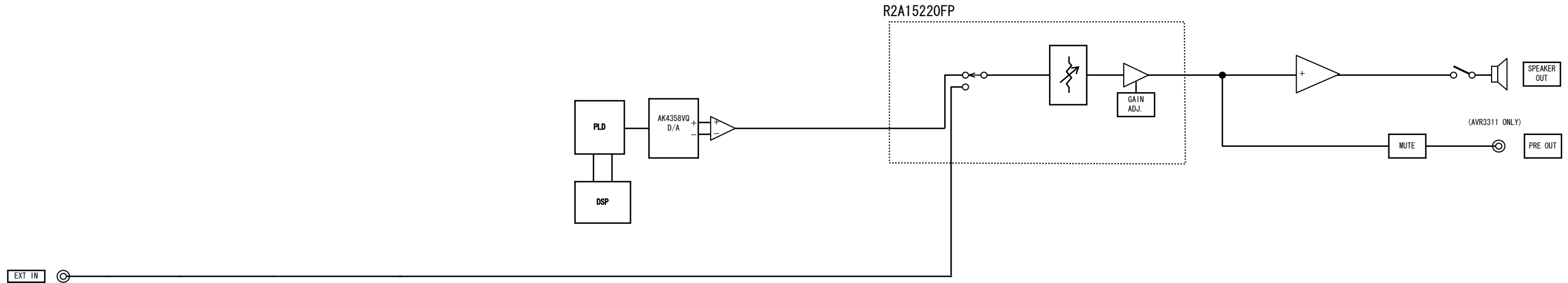

**LEVEL DIAGRAM
SUBWOOFER ch**

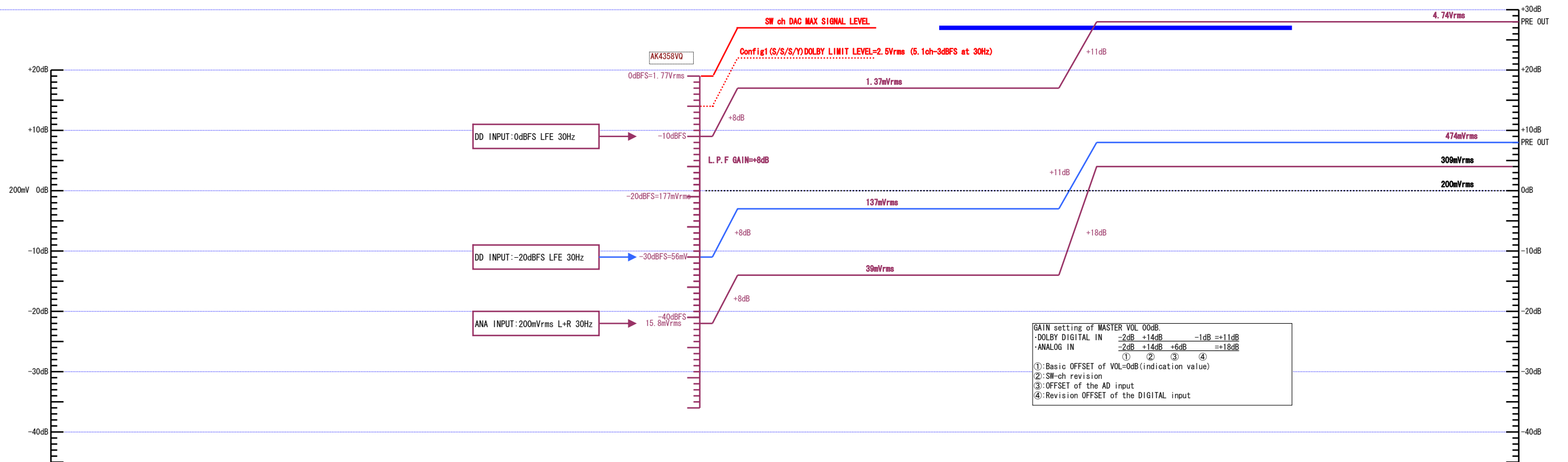
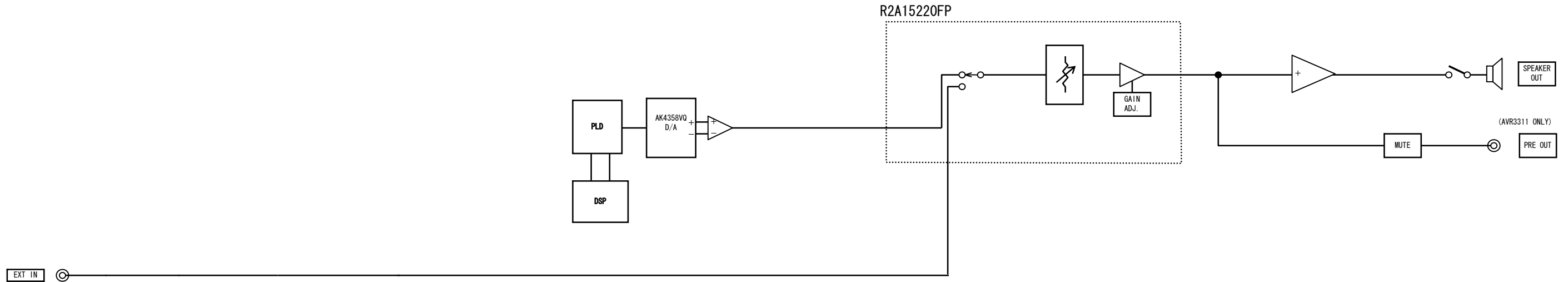

LEVEL DIAGRAM
SURROUND ch

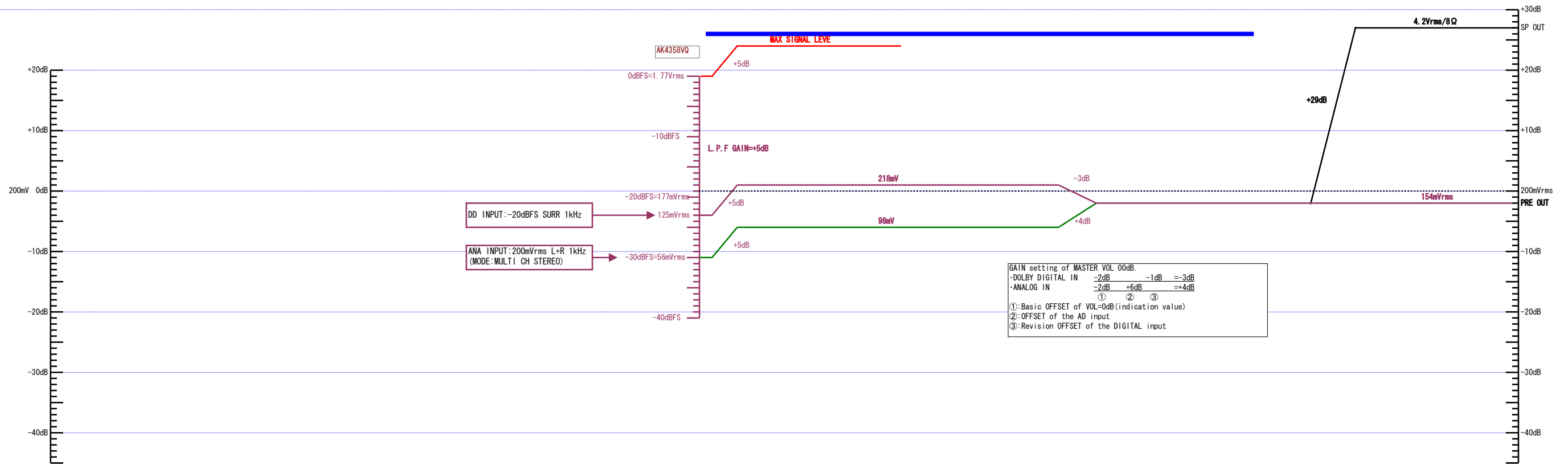
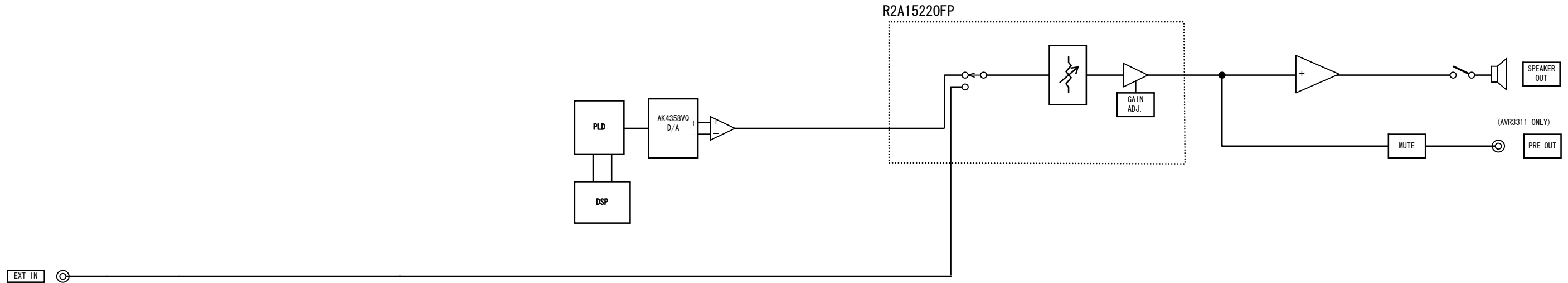

LEVEL DIAGRAM
SURR.BACK ch

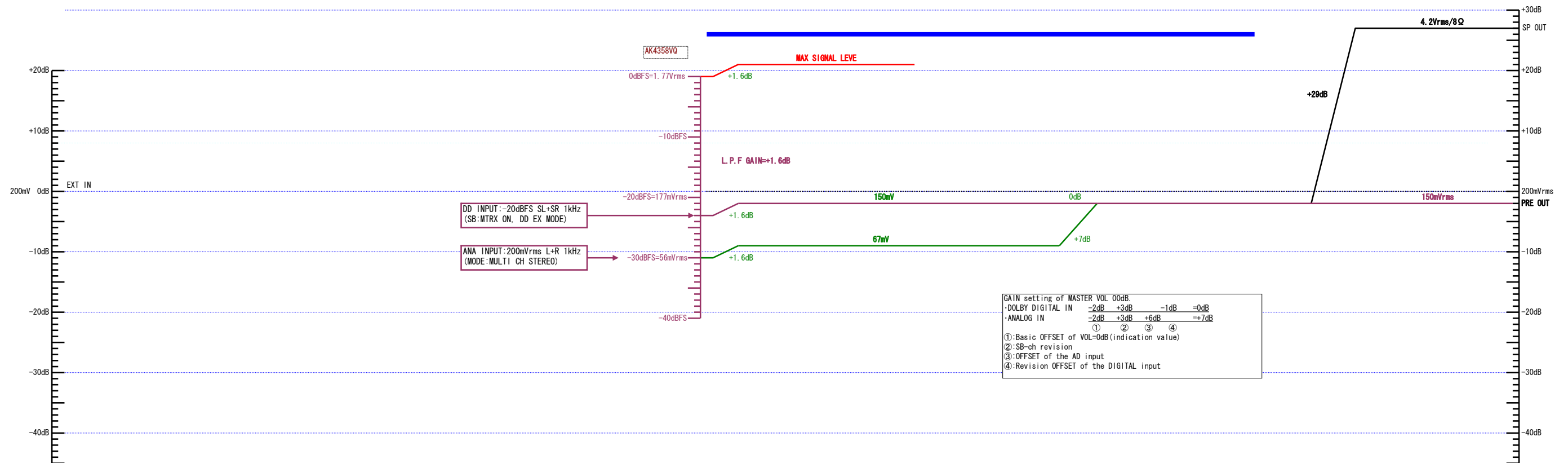
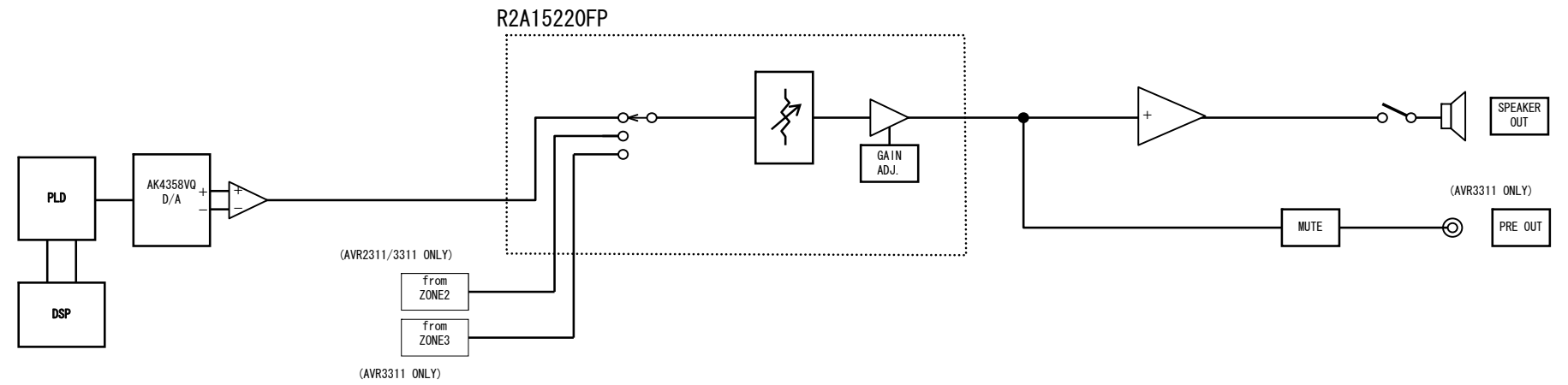

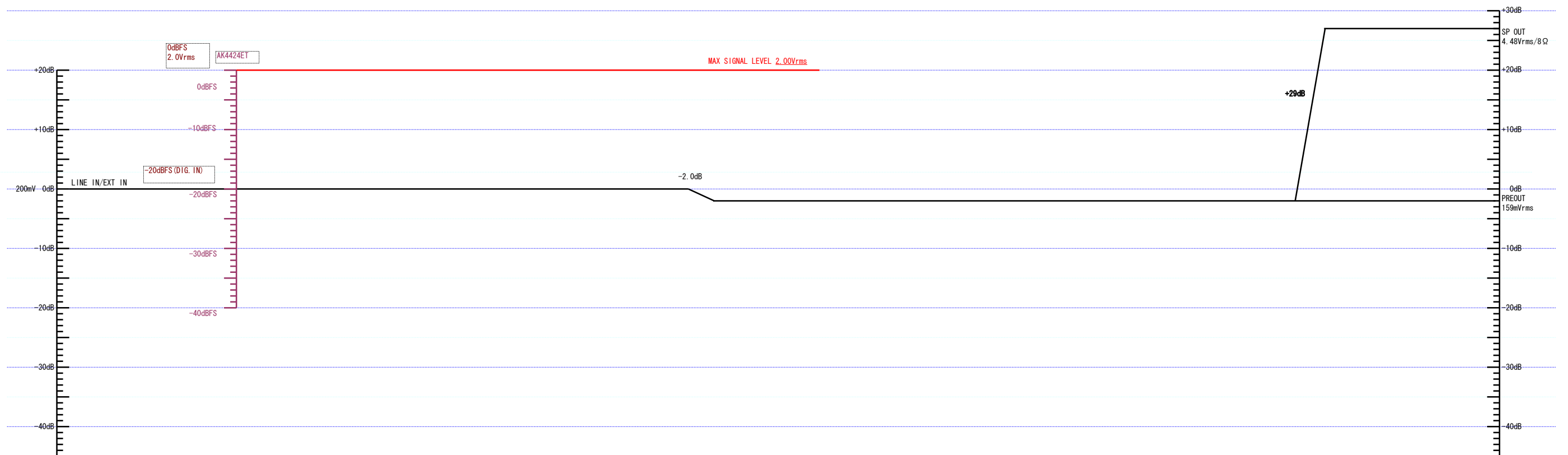
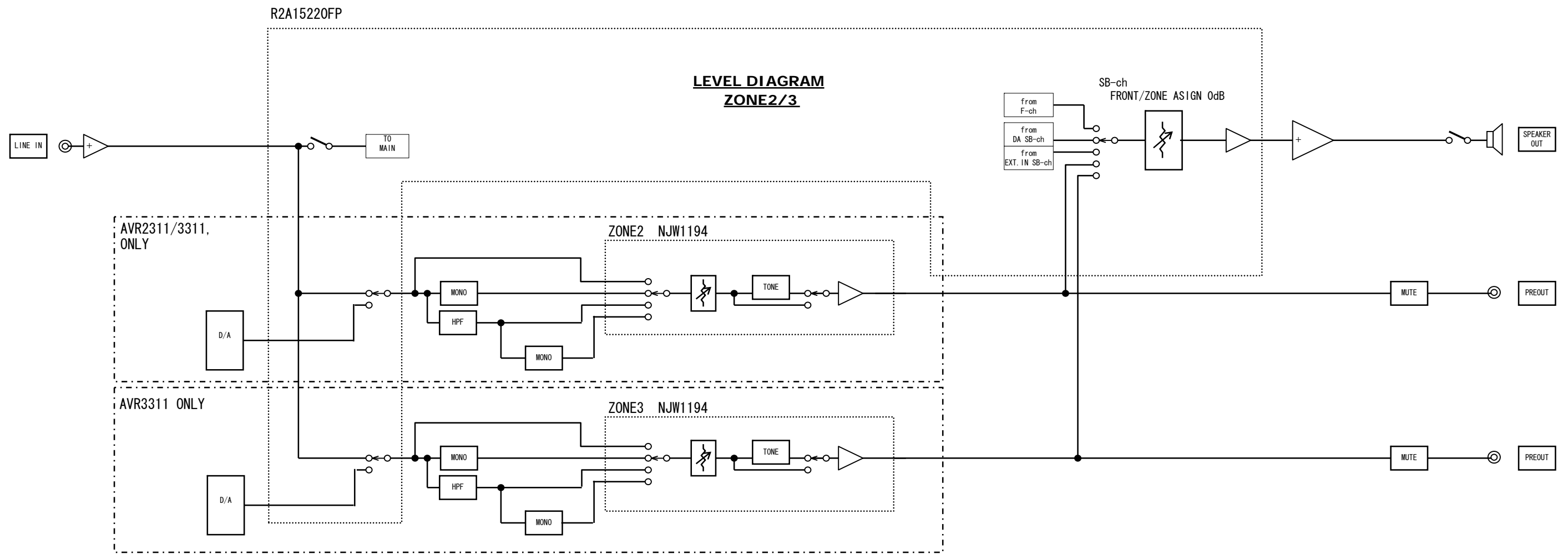

PRINTED WIRING BOARDS

7CH-AMP (COMPONENT SIDE)

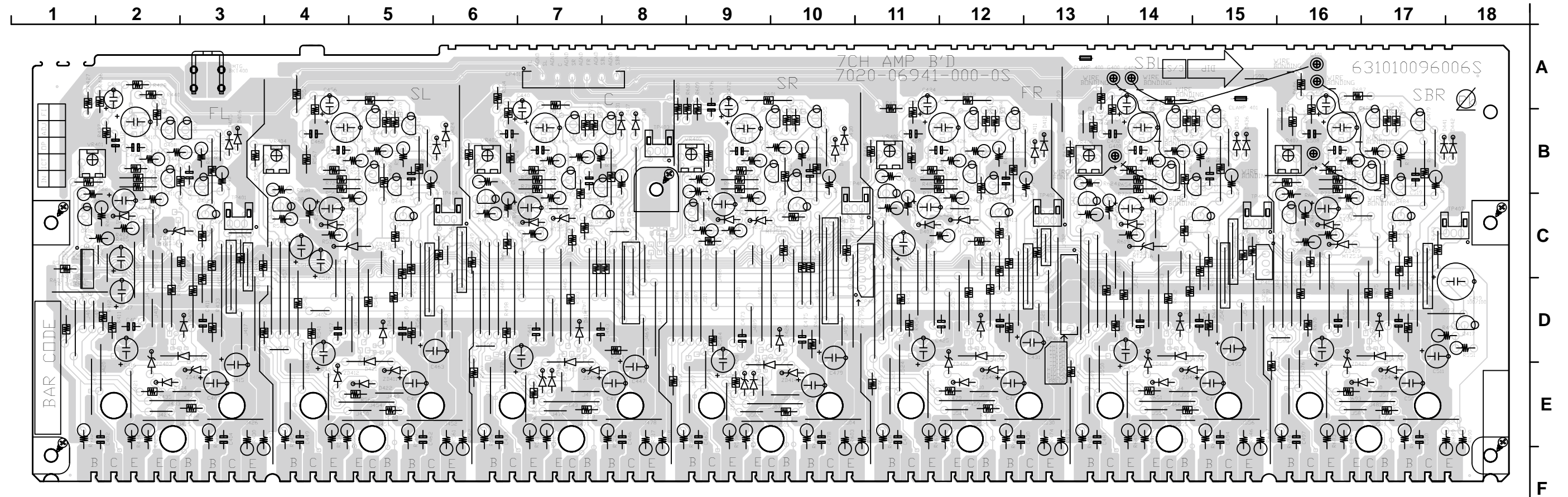

7CH-AMP (FOIL SIDE)

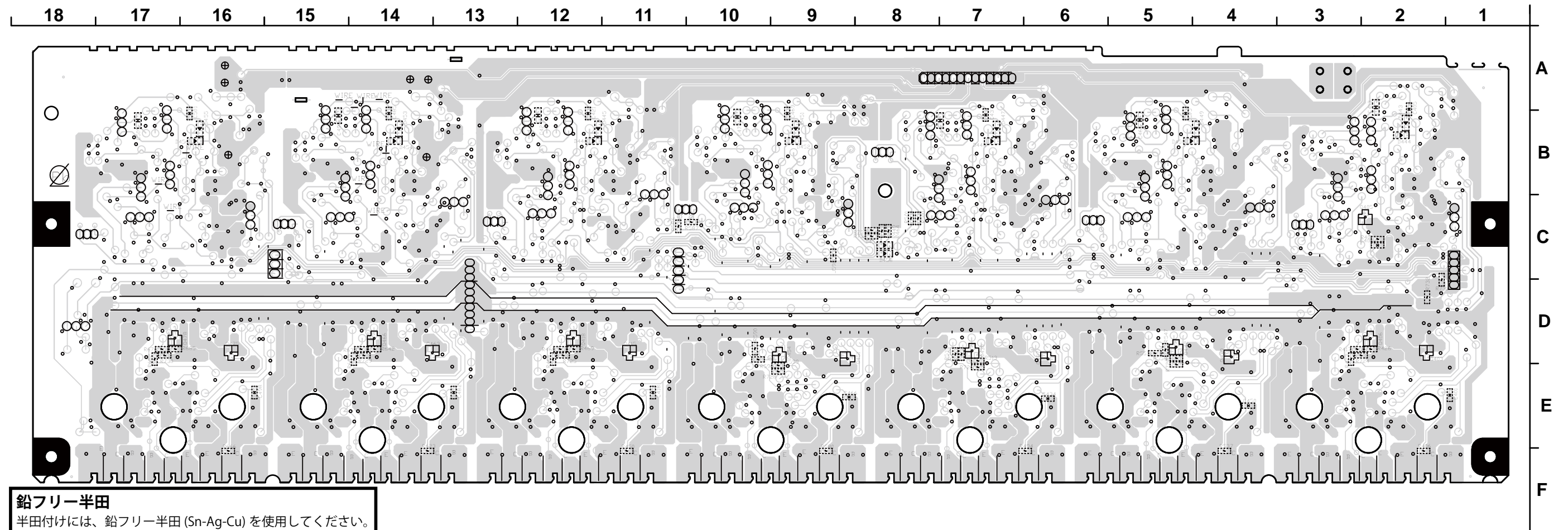

鉛フリー半田

半田付けには、鉛フリー半田 (Sn-Ag-Cu) を使用してください。

Lead-free Solder

When soldering, use the Lead-free Solder (Sn-Ag-Cu).

SMPS (COMPONENT SIDE)

1 2 3 4 5 6 7 8 9 10 11 12

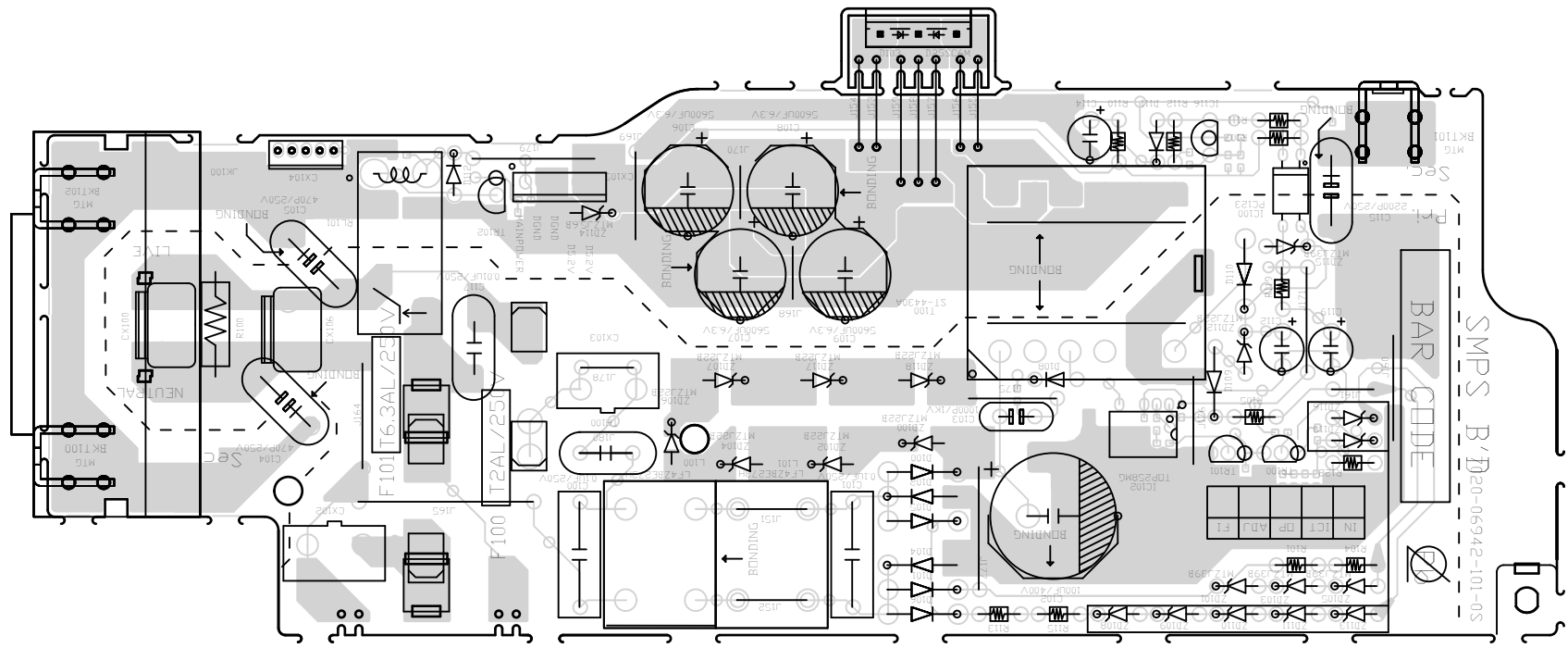

A
B
C
D
E
F

SMPS (FOIL SIDE)

12 11 10 9 8 7 6 5 4 3 2 1

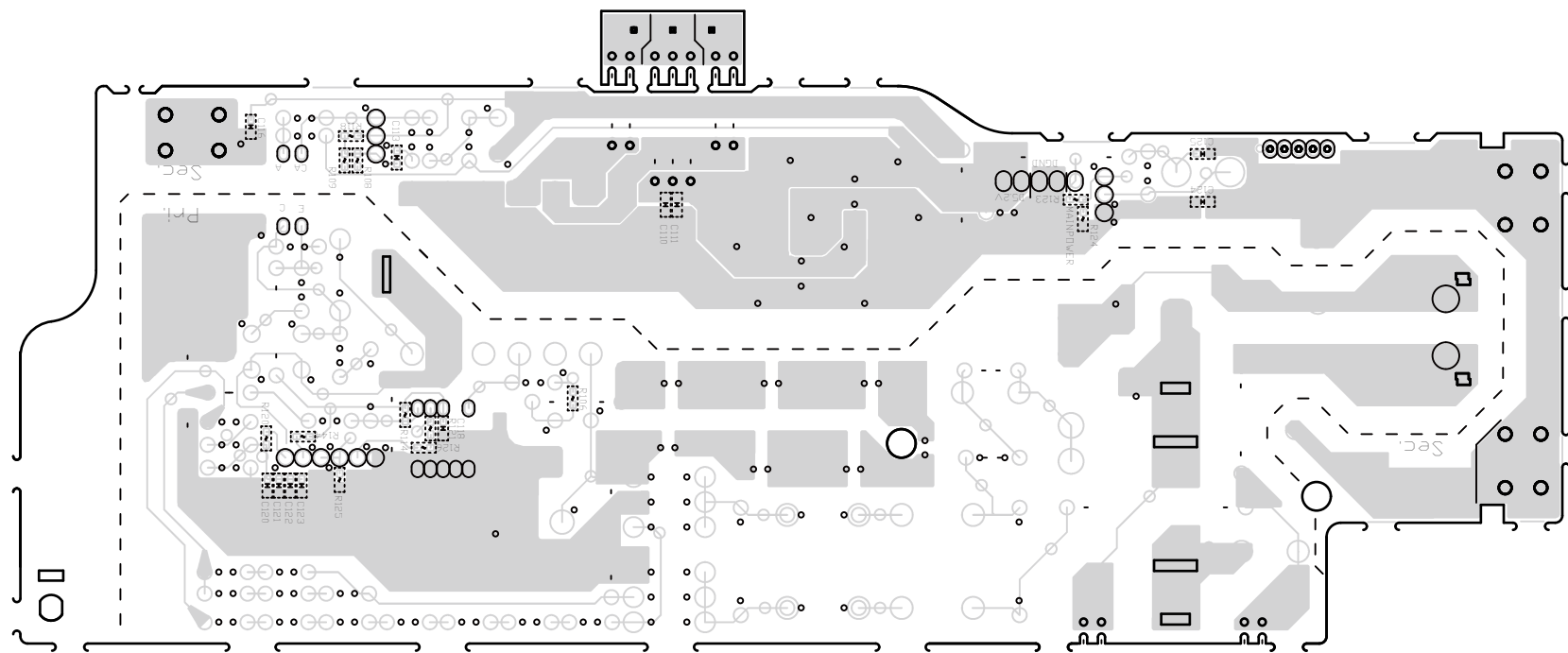

A
B
C
D
E
F

鉛フリー半田
半田付けには、鉛フリー半田 (Sn-Ag-Cu) を使用してください。

Lead-free Solder
When soldering, use the Lead-free Solder (Sn-Ag-Cu).

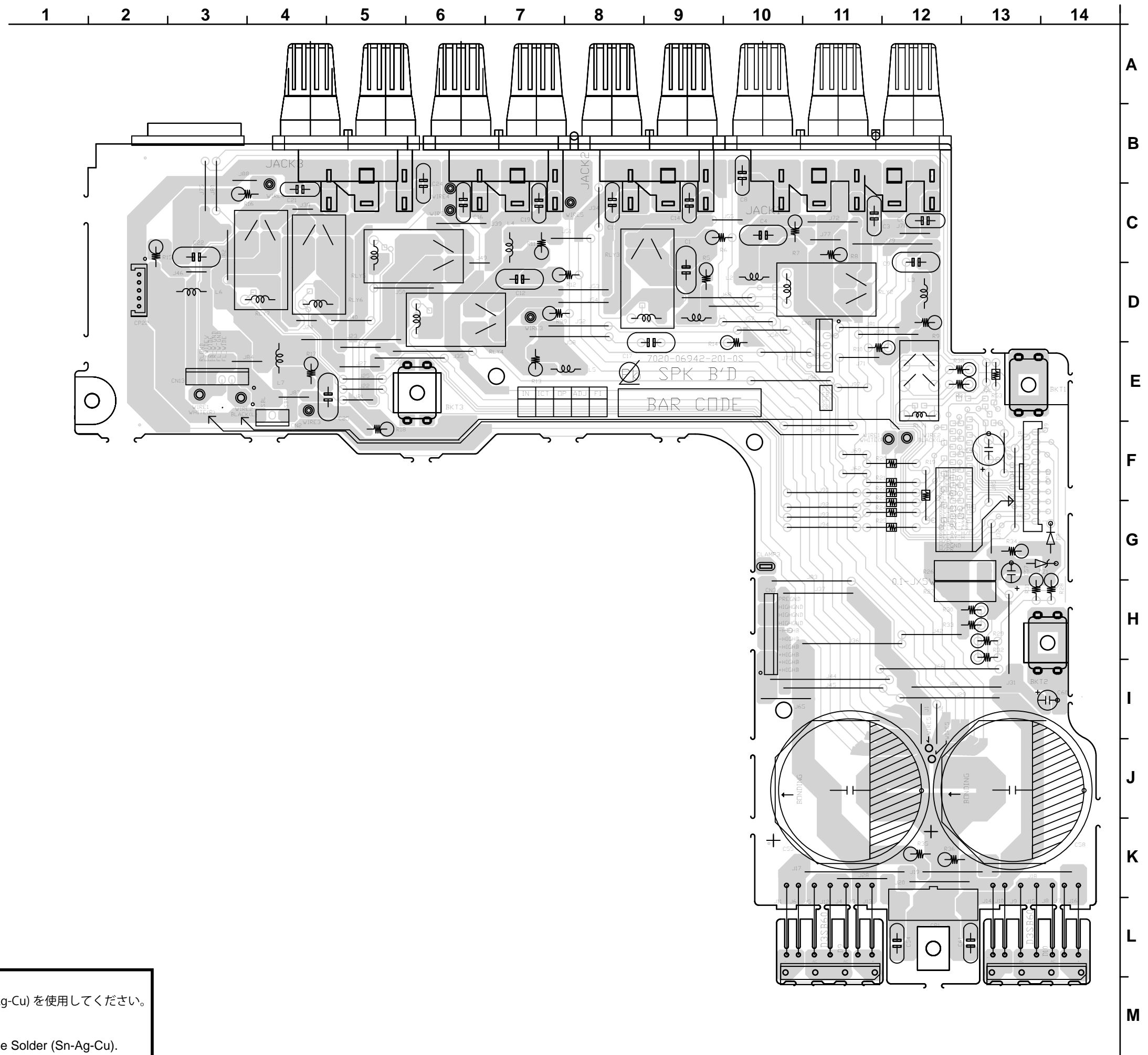

鉛フリー半田

半田付けには、鉛フリー半田 (Sn-Ag-Cu) を使用してください。

Lead-free Solder

When soldering, use the Lead-free Solder (Sn-Ag-Cu).

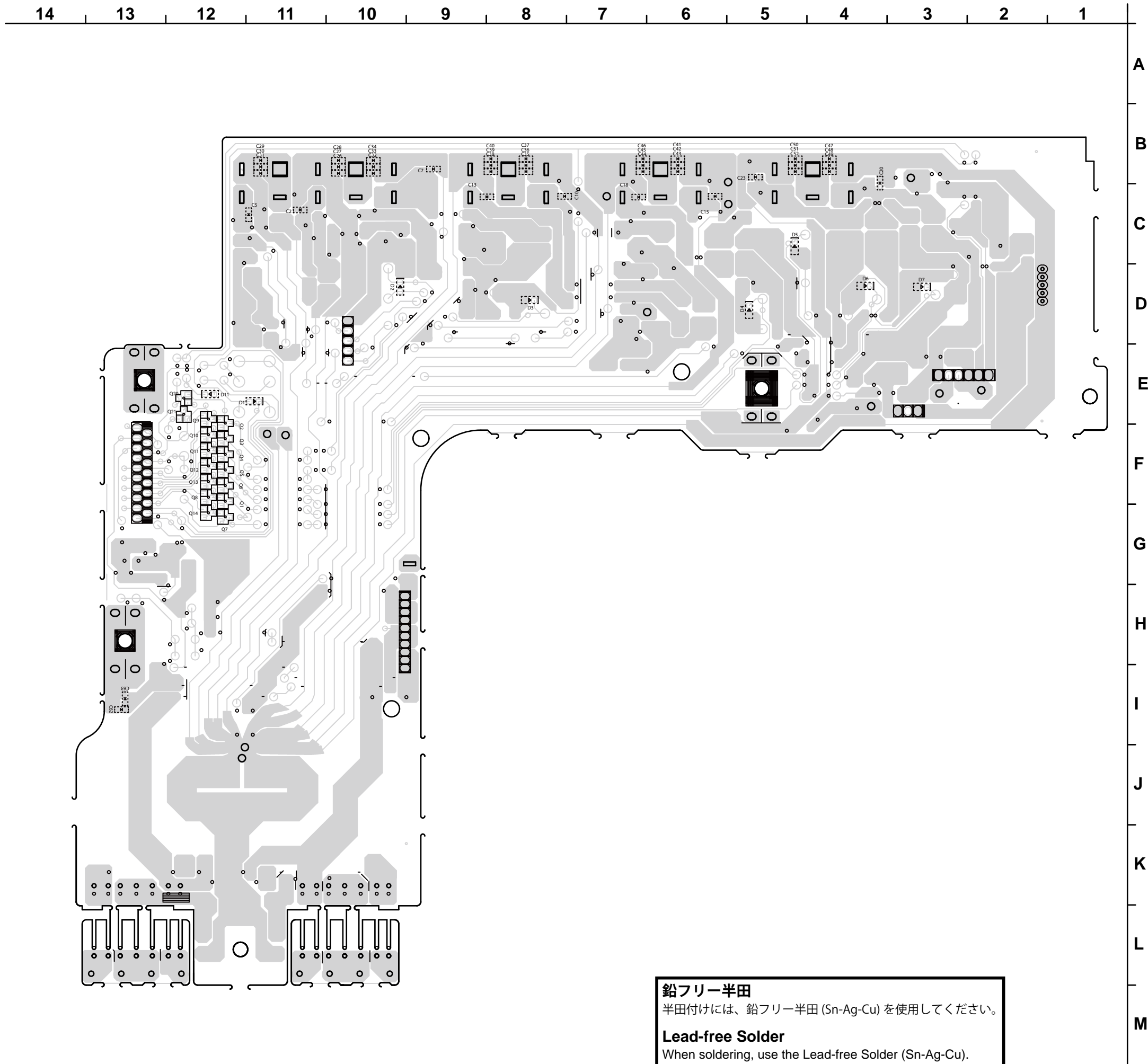

鉛フリー半田
 半田付けには、鉛フリー半田 (Sn-Ag-Cu) を使用してください。

Lead-free Solder
 When soldering, use the Lead-free Solder (Sn-Ag-Cu).

REG (COMPONENT SIDE)

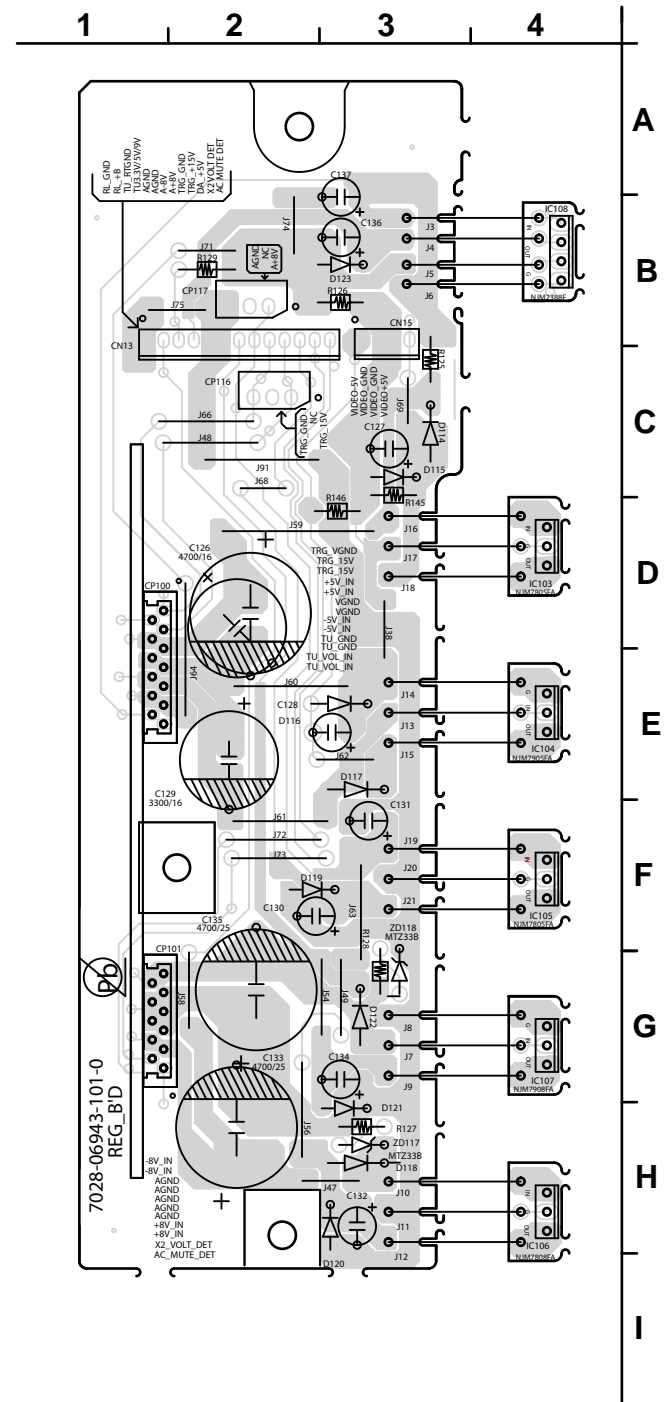

FRONT_CNT (COMPONENT SIDE)

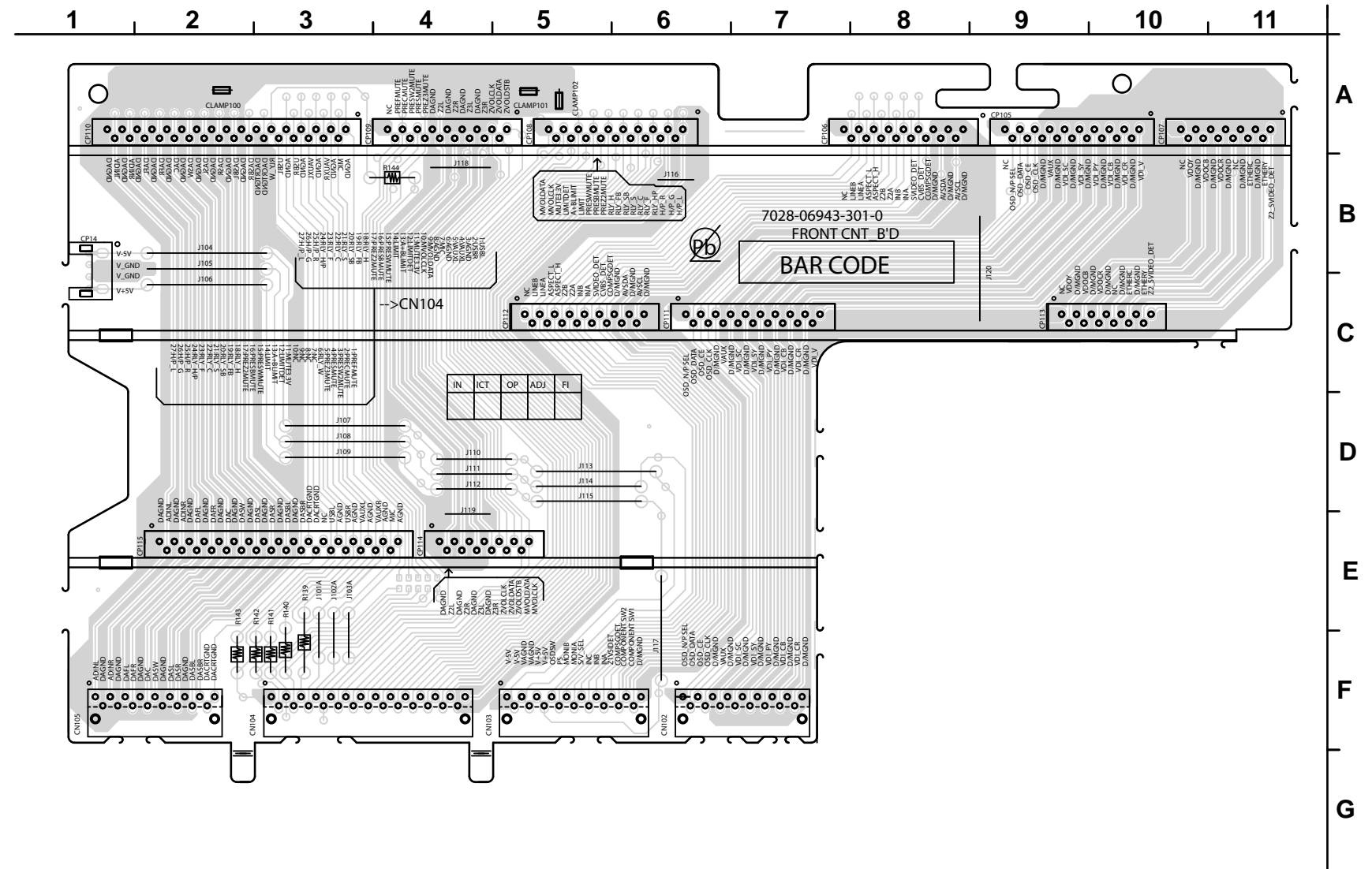

REG_CNT (COMPONENT SIDE)

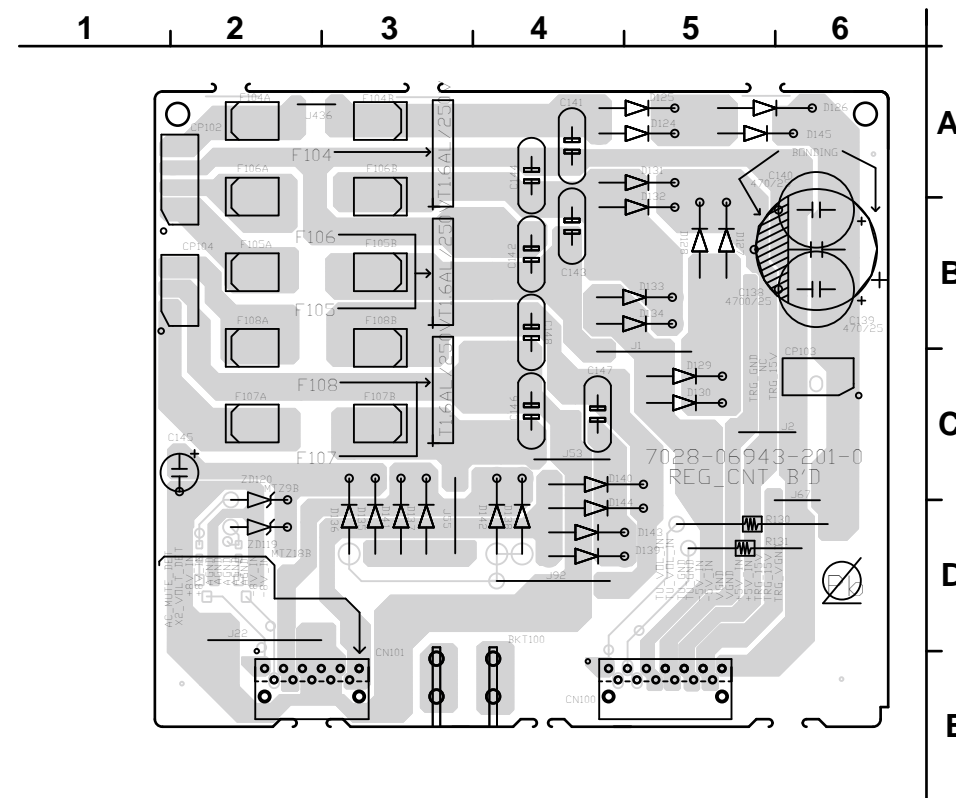

鉛フリー半田
半田付けには、鉛フリー半田 (Sn-Ag-Cu) を使用してください。

Lead-free Solder
When soldering, use the Lead-free Solder (Sn-Ag-Cu).

REG (FOIL SIDE)

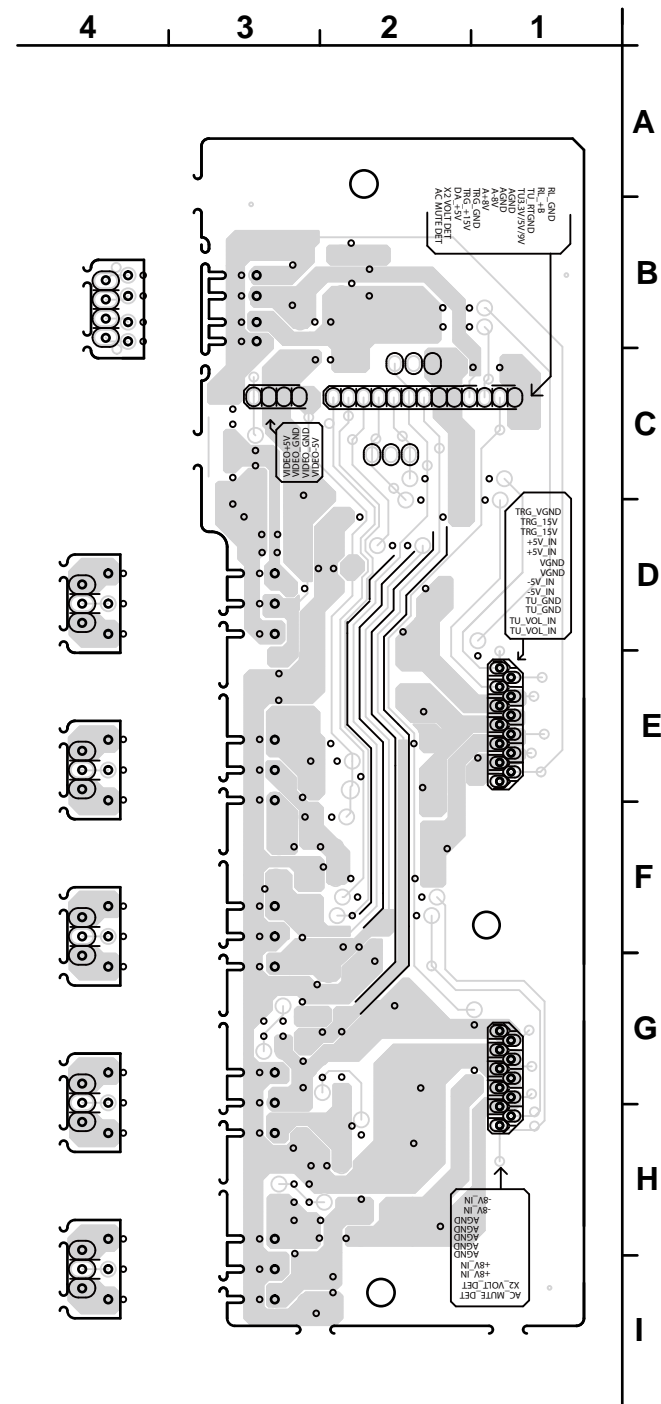

FRONT_CNT (FOIL SIDE)

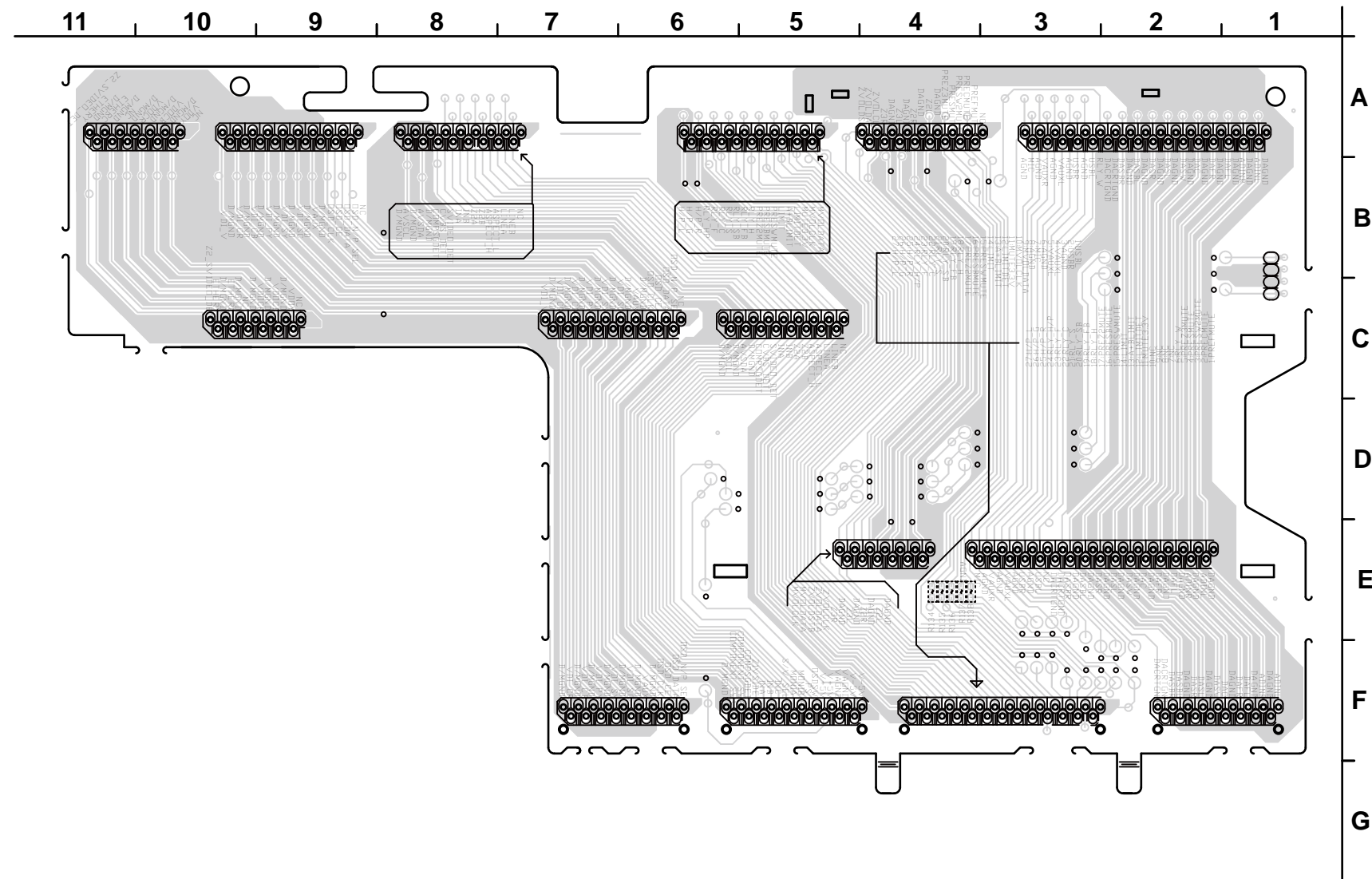

REG_CNT (FOIL SIDE)

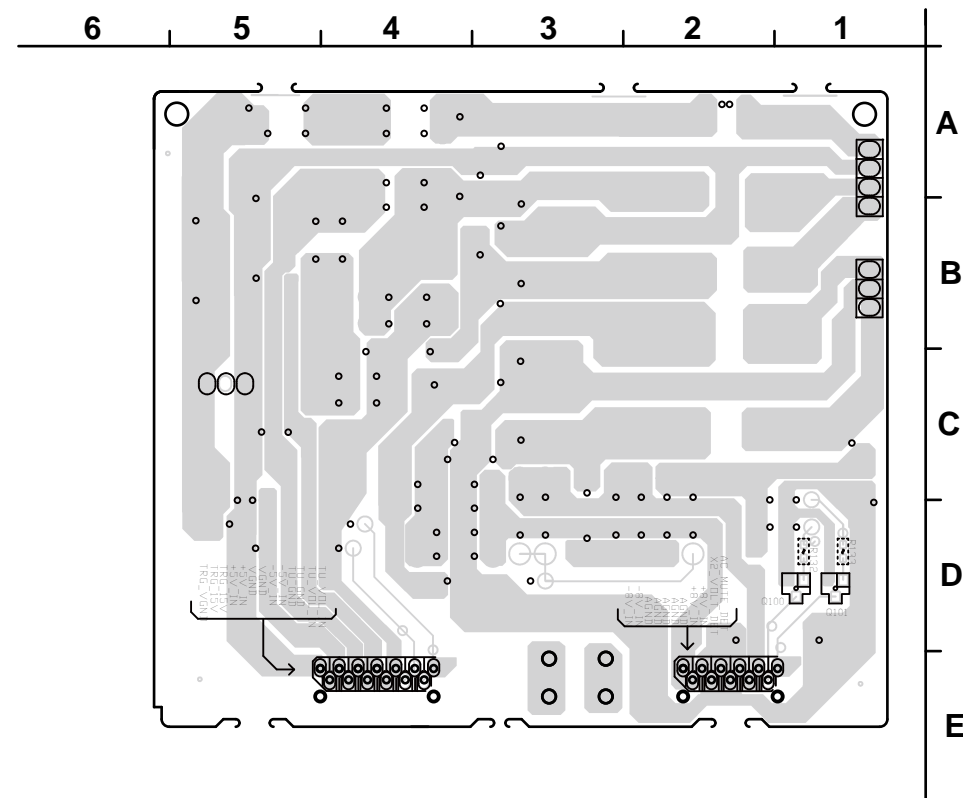

鉛フリー半田
半田付けには、鉛フリー半田 (Sn-Ag-Cu) を使用してください。
Lead-free Solder
When soldering, use the Lead-free Solder (Sn-Ag-Cu).

SIDE_CNT (COMPONENT SIDE)

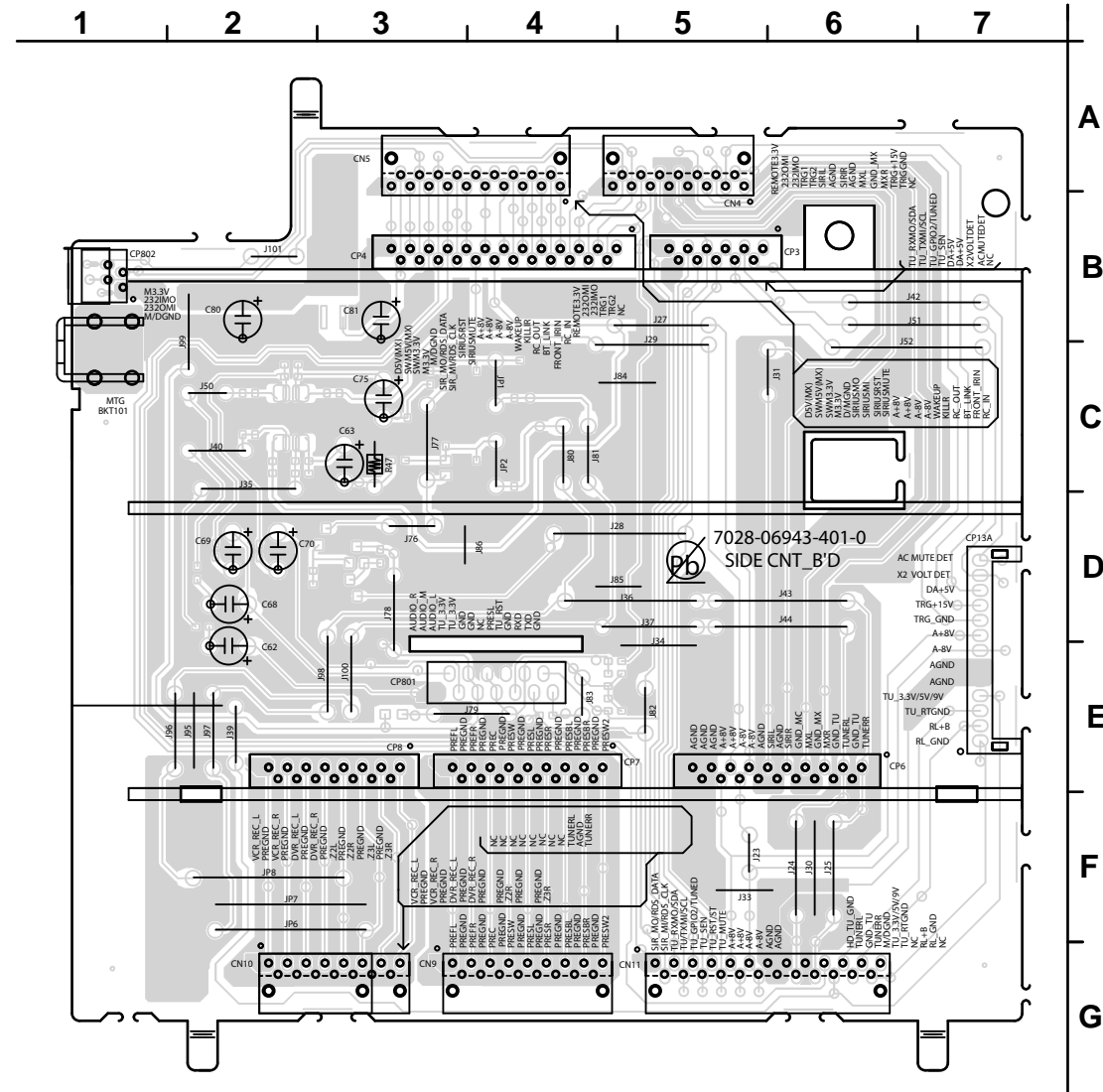

SIDE_CNT (FOIL SIDE)

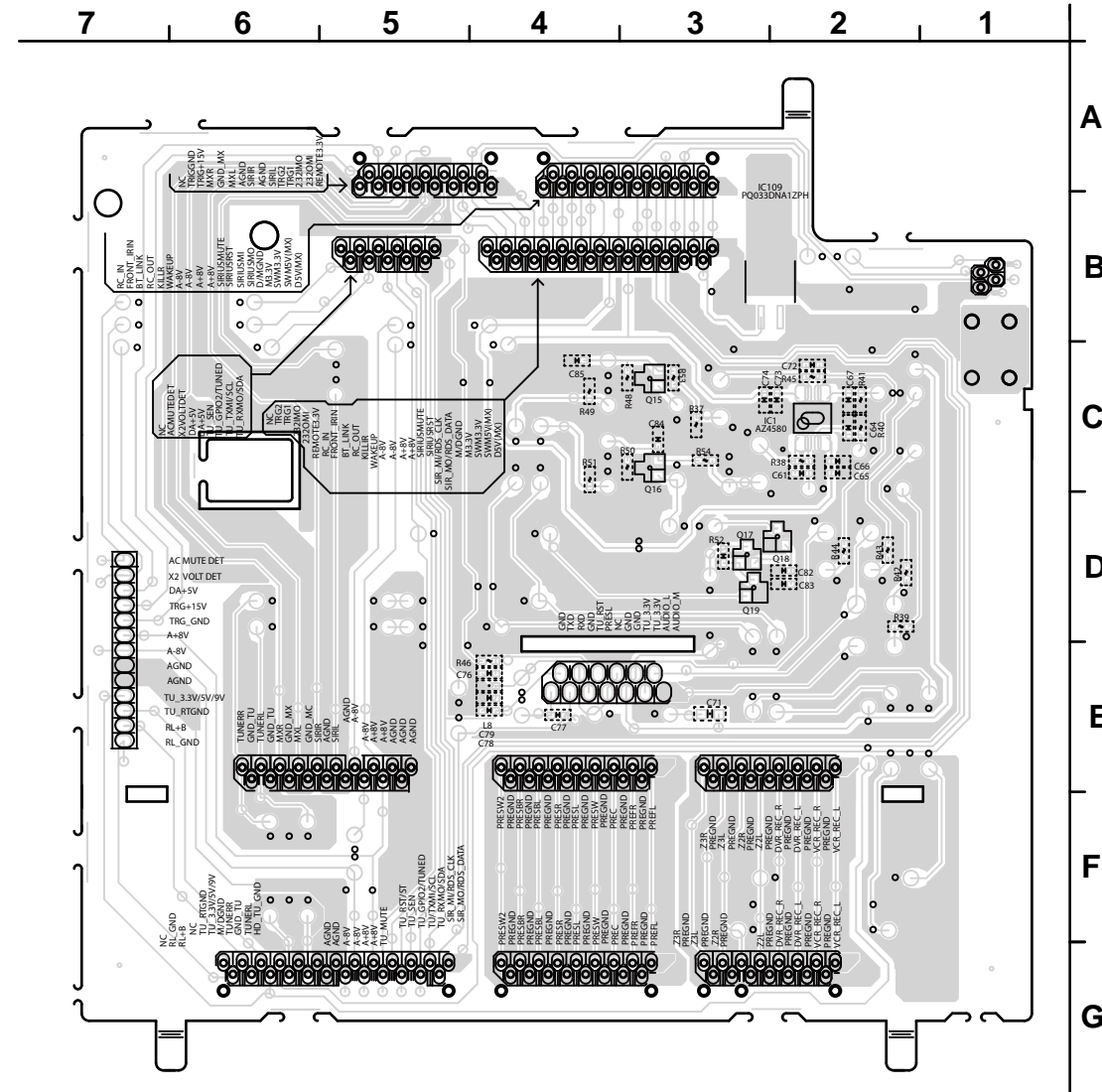

USB (COMPONENT SIDE)

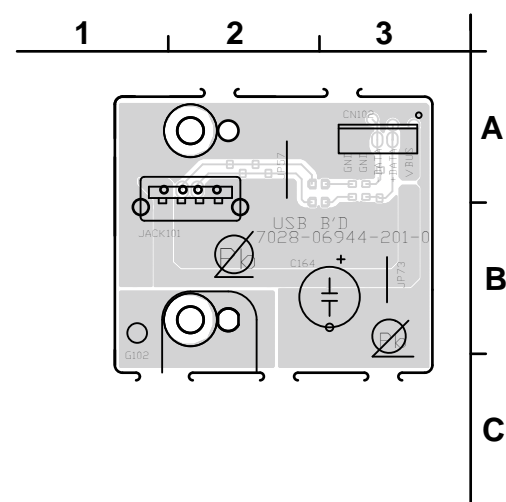

USB (FOIL SIDE)

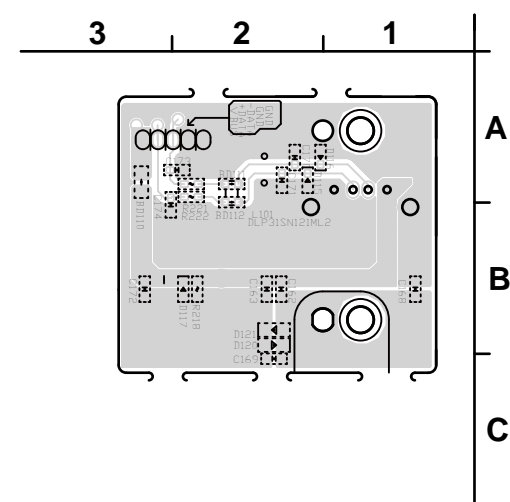

H/P (COMPONENT SIDE)

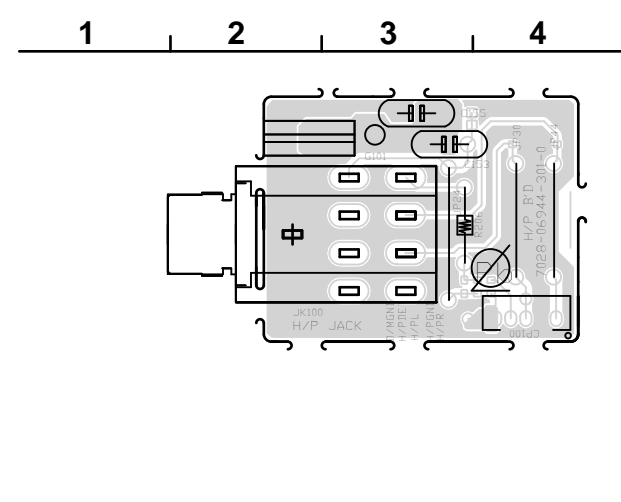

H/P (FOIL SIDE)

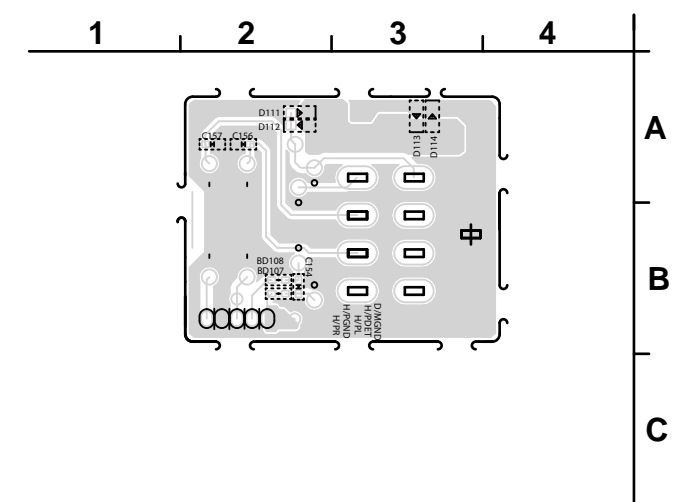

鉛フリー半田

半田付けには、鉛フリー半田 (Sn-Ag-Cu) を使用してください。

Lead-free Solder

When soldering, use the Lead-free Solder (Sn-Ag-Cu).

FRONT (COMPONENT SIDE)

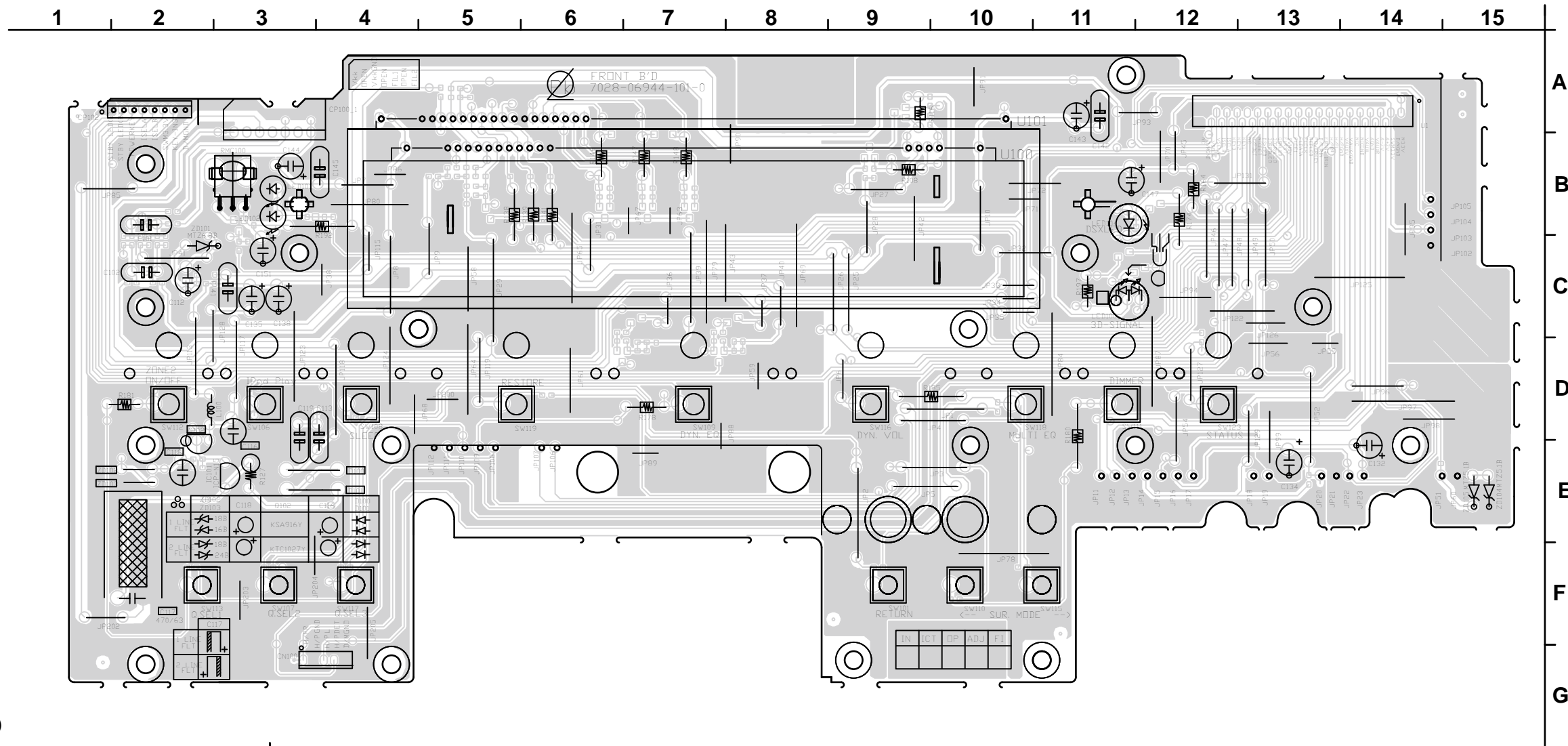

FUNCTION (COMPONENT SIDE)

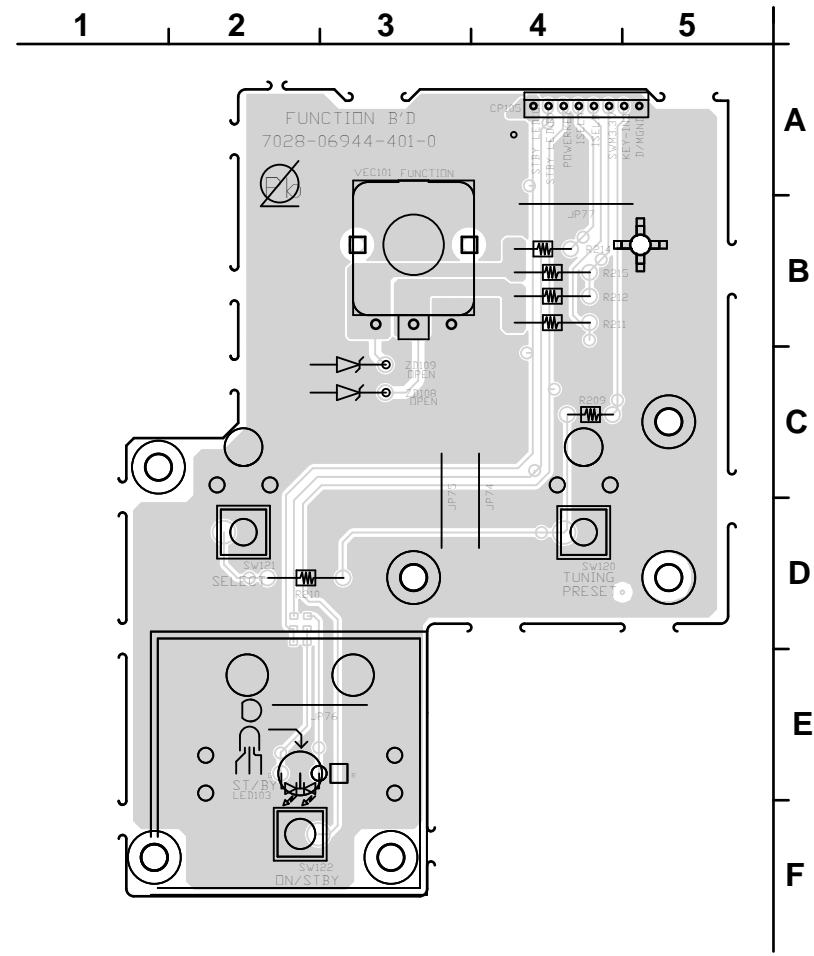

FUNCTION_CNT (COMPONENT SIDE)

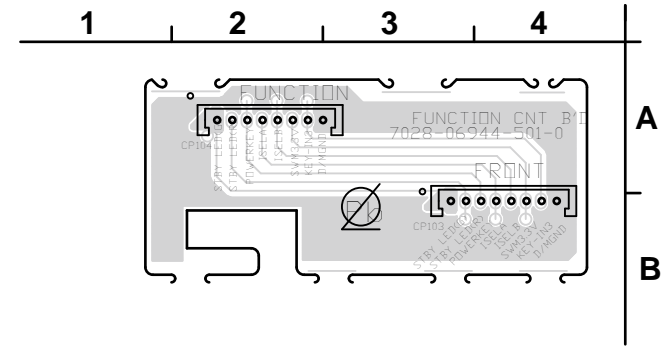

鉛フリー半田
半田付けには、鉛フリー半田 (Sn-Ag-Cu) を使用してください。

Lead-free Solder
When soldering, use the Lead-free Solder (Sn-Ag-Cu).

FRONT (FOIL SIDE)

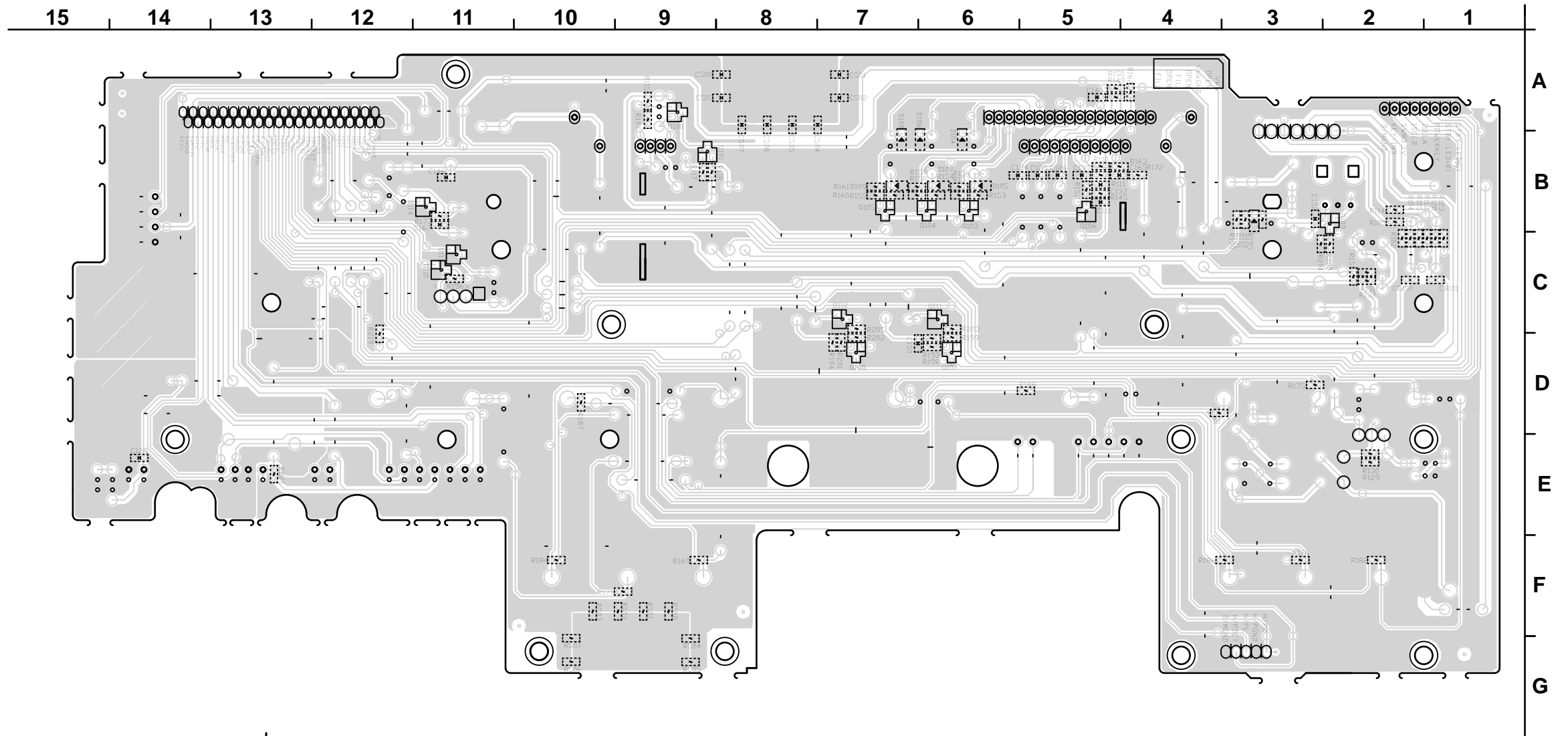

FUNCTION (FOIL SIDE)

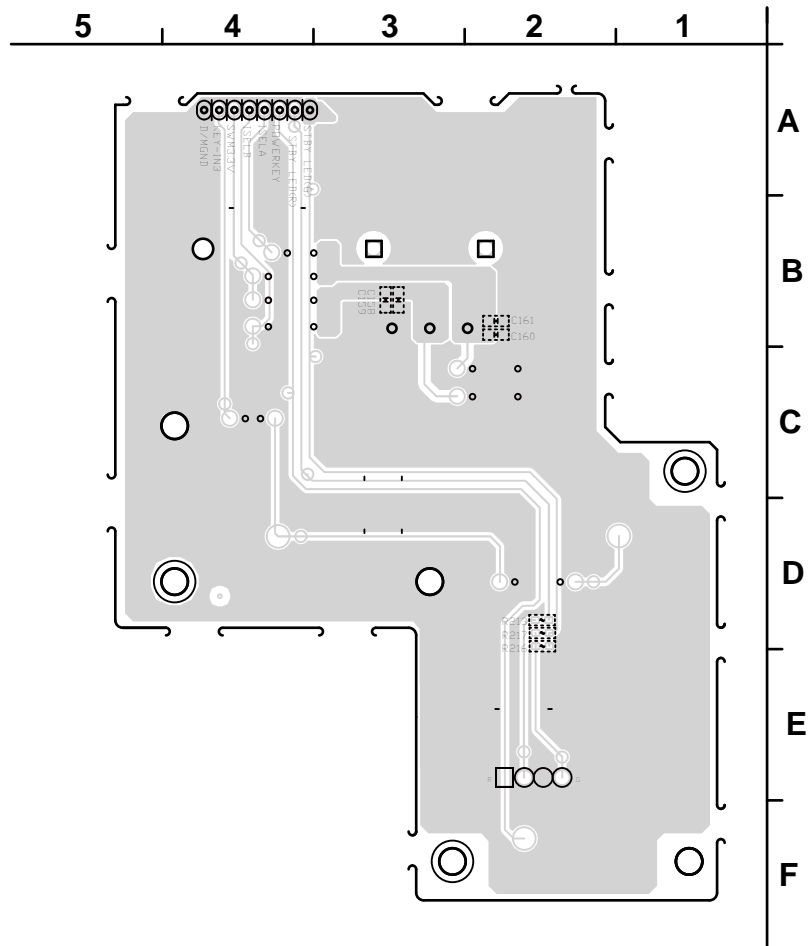

FUNCTION_CNT (FOIL SIDE)

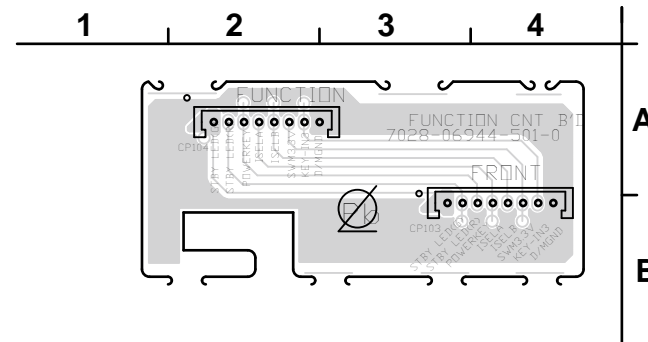

鉛フリー半田
半田付けには、鉛フリー半田 (Sn-Ag-Cu) を使用してください。

Lead-free Solder
When soldering, use the Lead-free Solder (Sn-Ag-Cu).

1 2 3 4 5 6 7 8 9

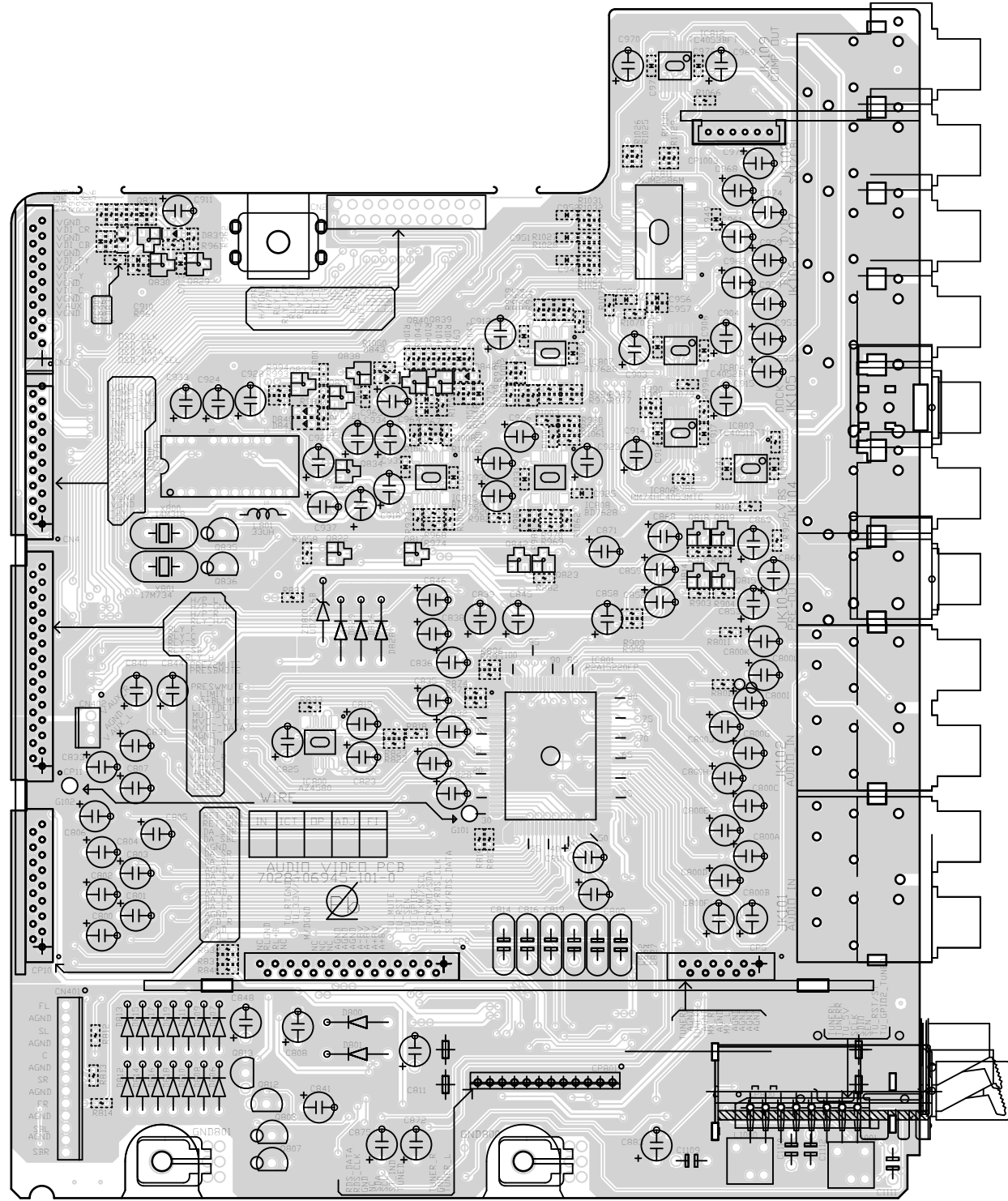

A
B
C
D
E
F
G
H
I
J
K

9 8 7 6 5 4 3 2 1

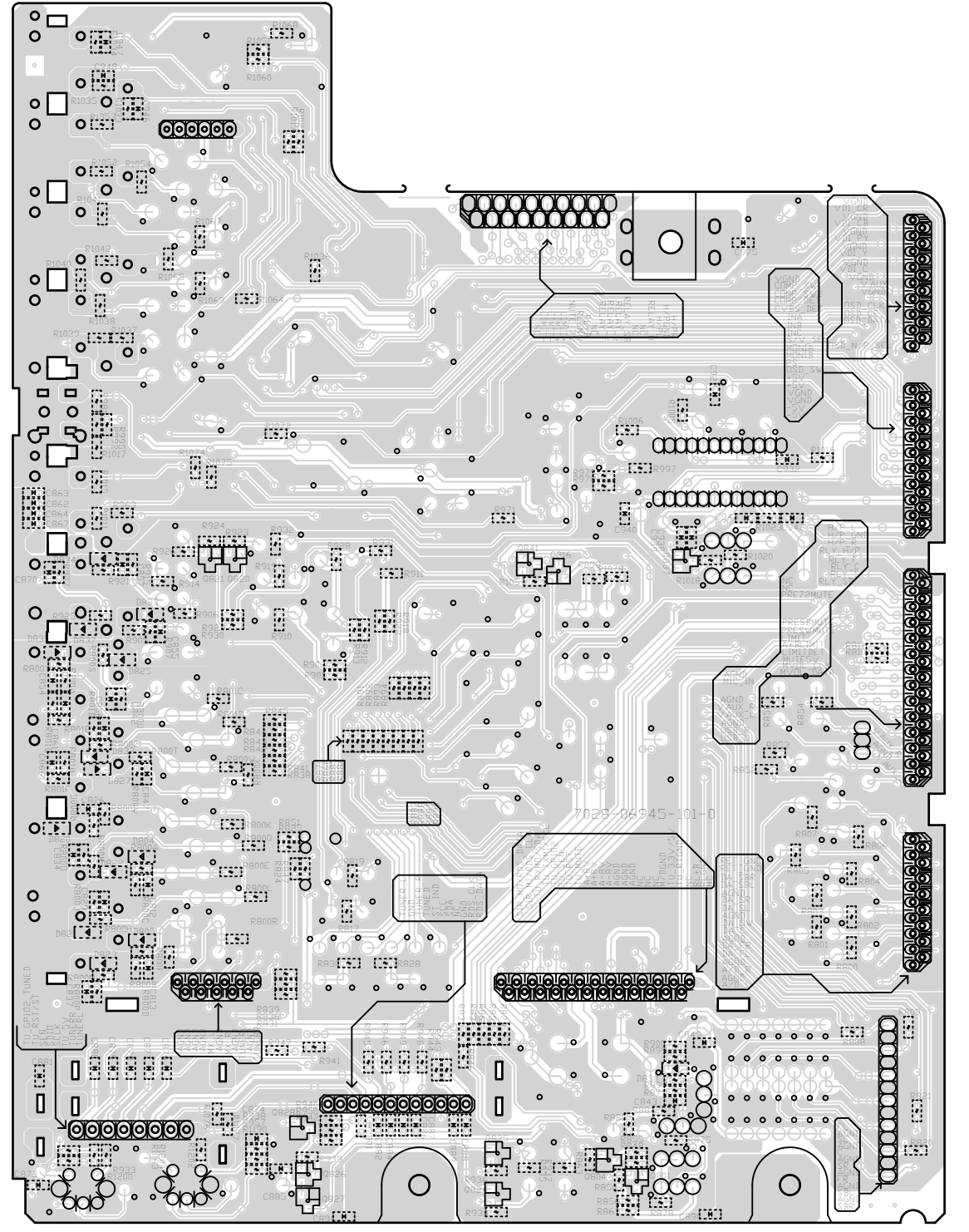

A
B
C
D
E
F
G
H
I
J
K

鉛フリー半田
半田付けには、鉛フリー半田 (Sn-Ag-Cu) を使用してください。

Lead-free Solder
When soldering, use the Lead-free Solder (Sn-Ag-Cu).

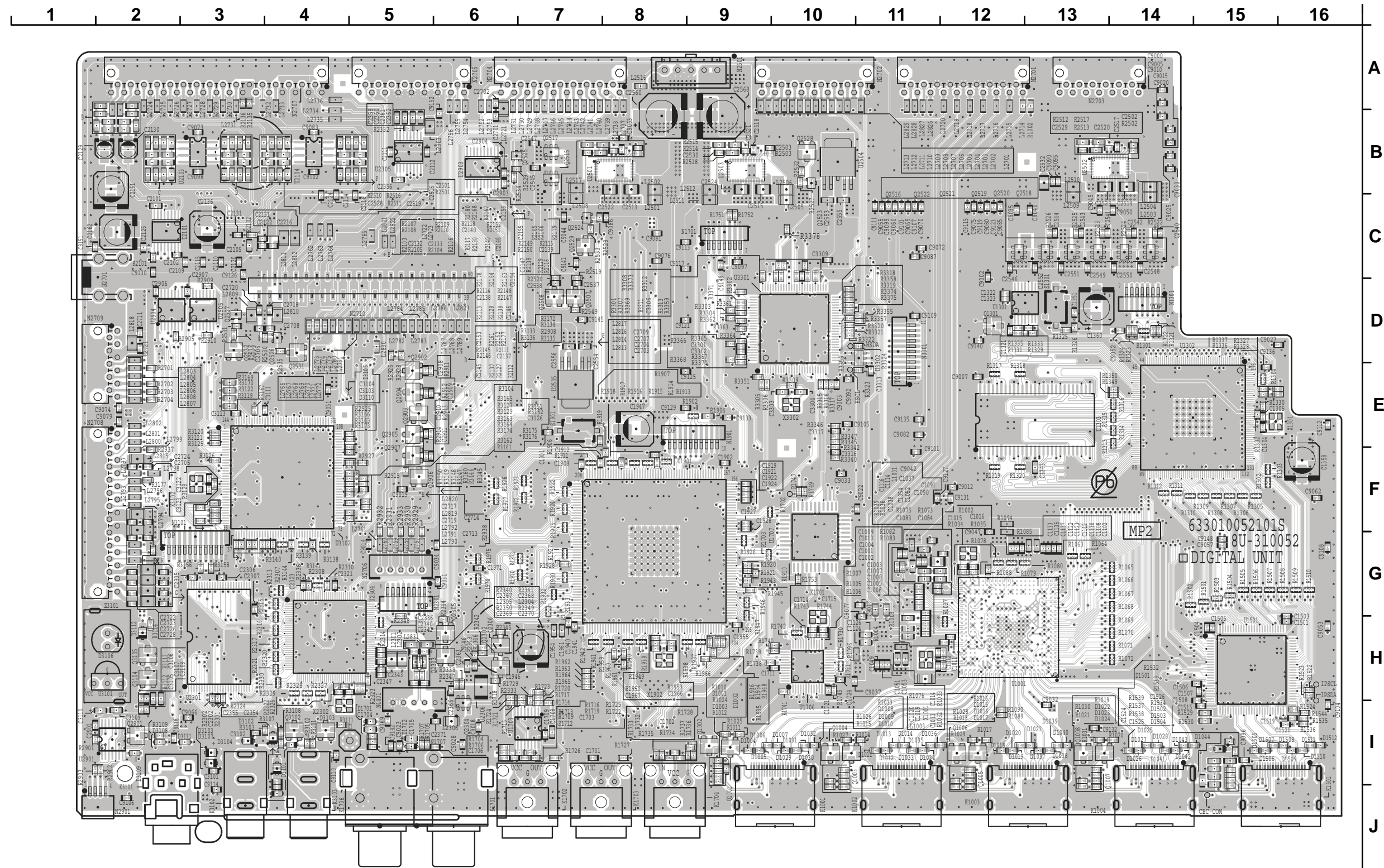

鉛フリー半田

半田付けには、鉛フリー半田 (Sn-Ag-Cu) を使用してください。

Lead-free Solder

When soldering, use the Lead-free Solder (Sn-Ag-Cu).

16 15 14 13 12 11 10 9 8 7 6 5 4 3 2 1

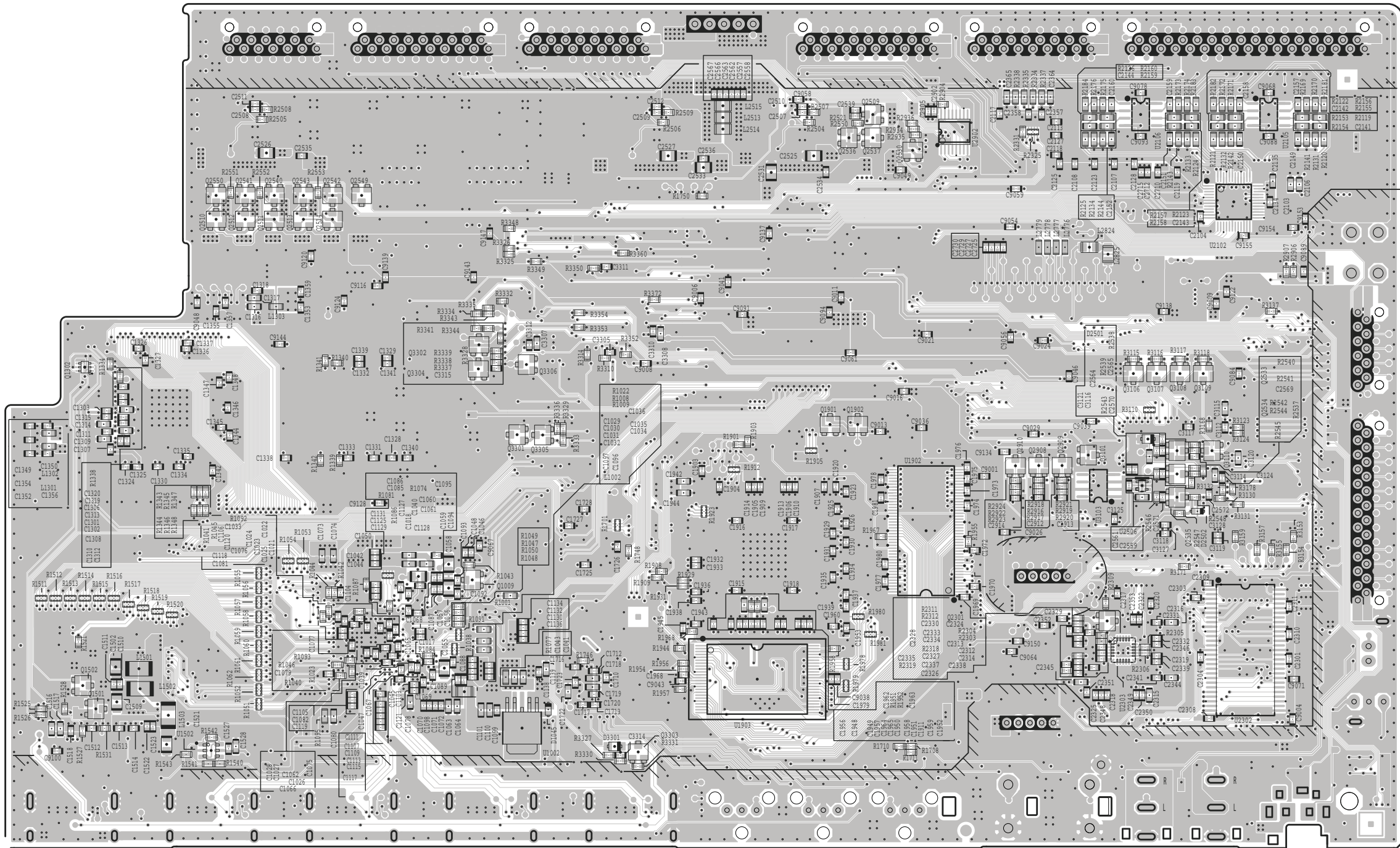

A
B
C
D
E
F
G
H
I
J

鉛フリー半田
半田付けには、鉛フリー半田 (Sn-Ag-Cu) を使用してください。
Lead-free Solder
When soldering, use the Lead-free Solder (Sn-Ag-Cu).

AMP B'D 1/2

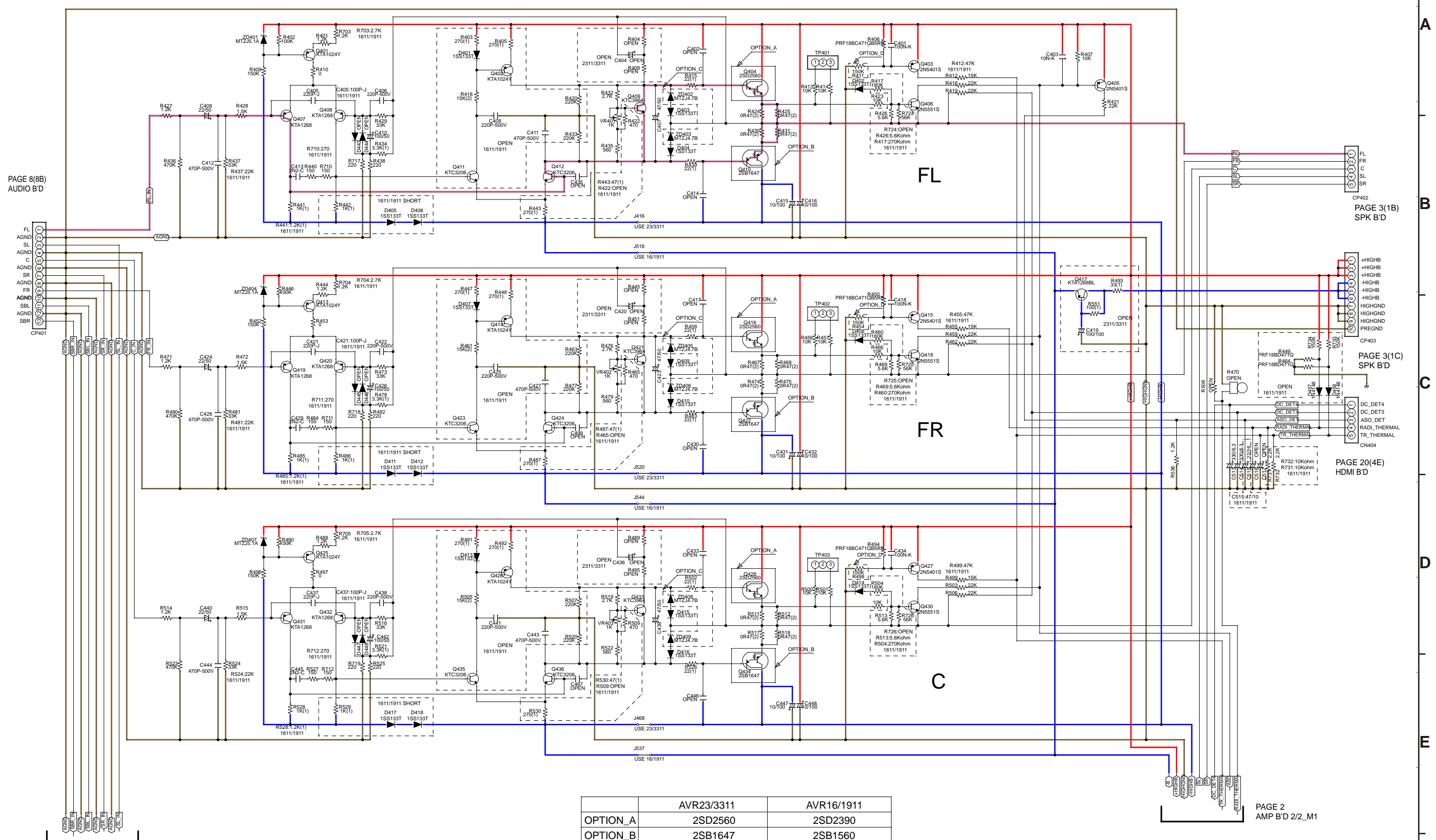

PAGE 8(8B)
AUDIO B'D

PAGE 3(1B)
SPK B'D

PAGE 3(1C)
SPK B'D

PAGE 20(4E)
HDMI B'D

PAGE 2
AMP B'D 2/2_A1

PAGE 2
AMP B'D 2/2_M1

	AVR23/3311	AVR16/1911
OPTION_A	2SD2560	2SD2390
OPTION_B	2SB1647	2SB1560
OPTION_C	MTZJ4.7B	MTZJ3.3B
	AVR1611 E3	With out AVR1611E3
OPTION_D	150K	270K

ANALOG AUDIO SIGNAL LINE
SCHEMATIC DIAGRAMS (1/23)

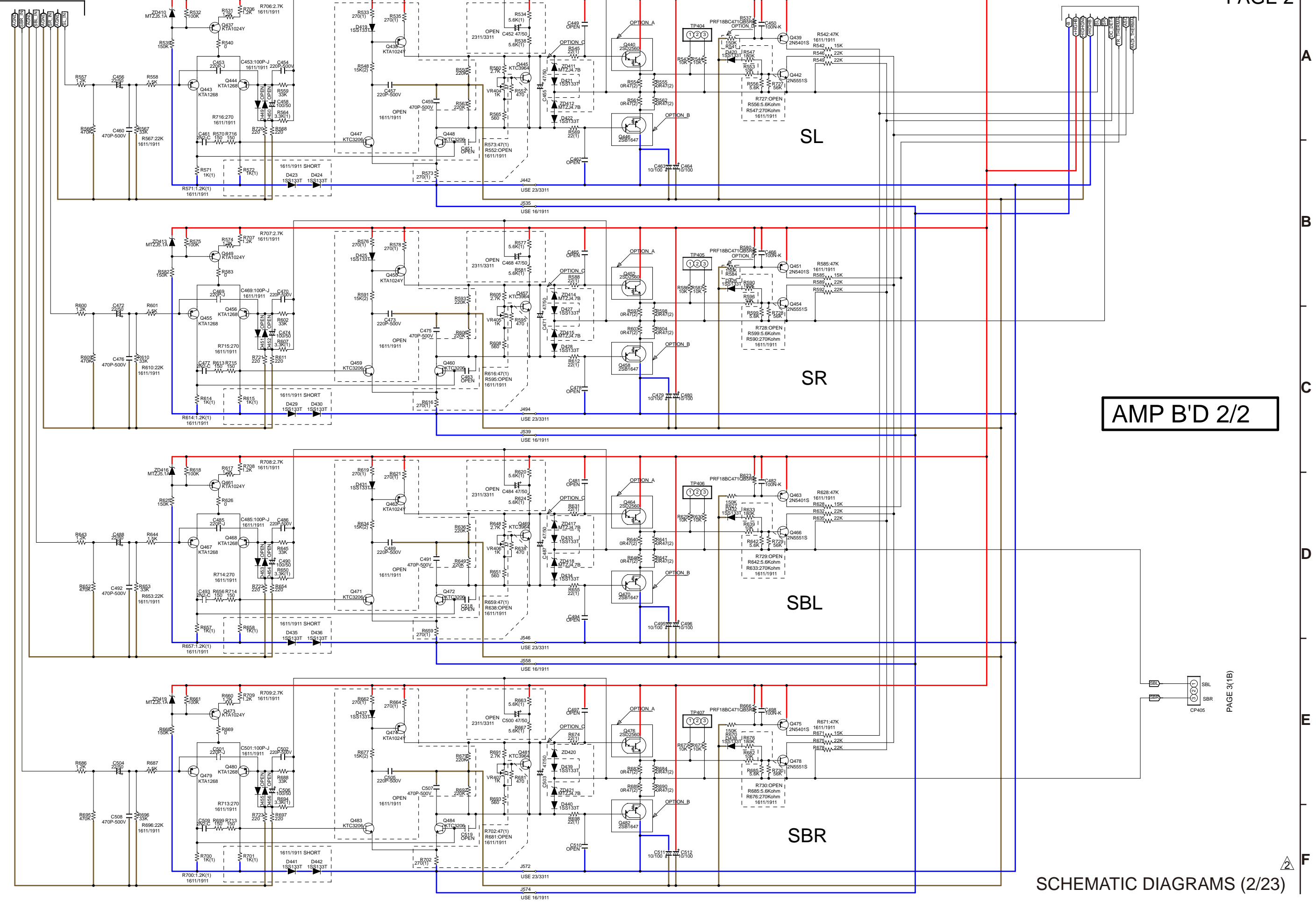

AMP B'D 2/2

PAGE 3(1B)

SPEAKER B'D

SPK_SMPS 1/2

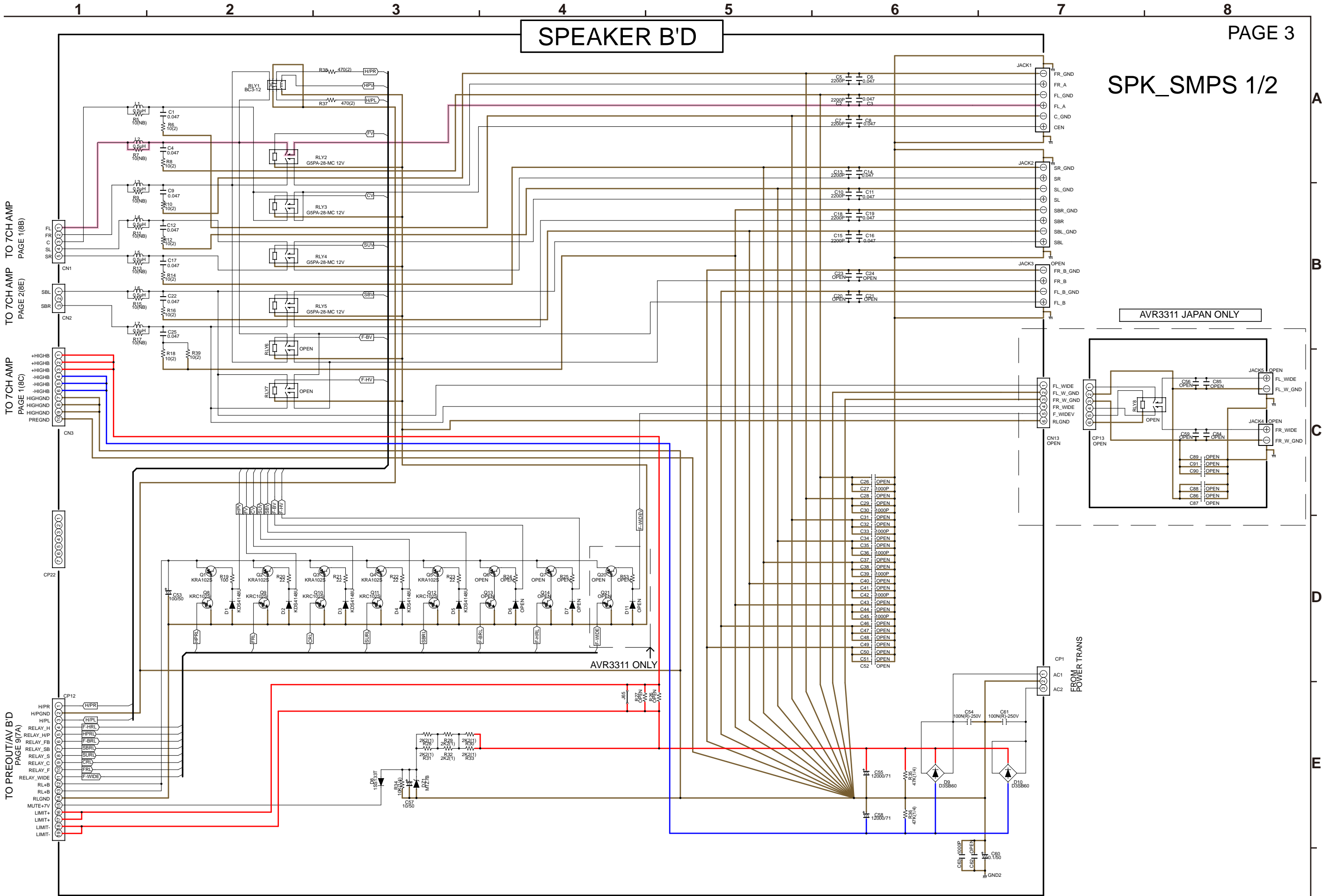

TO 7CH AMP PAGE 2(8E)

TO 7CH AMP PAGE 1(8C)

TO PREOUT/AV B'D PAGE 9(7A)

ANALOG AUDIO SIGNAL LINE

SCHEMATIC DIAGRAMS (3/23)

SMPS B'D

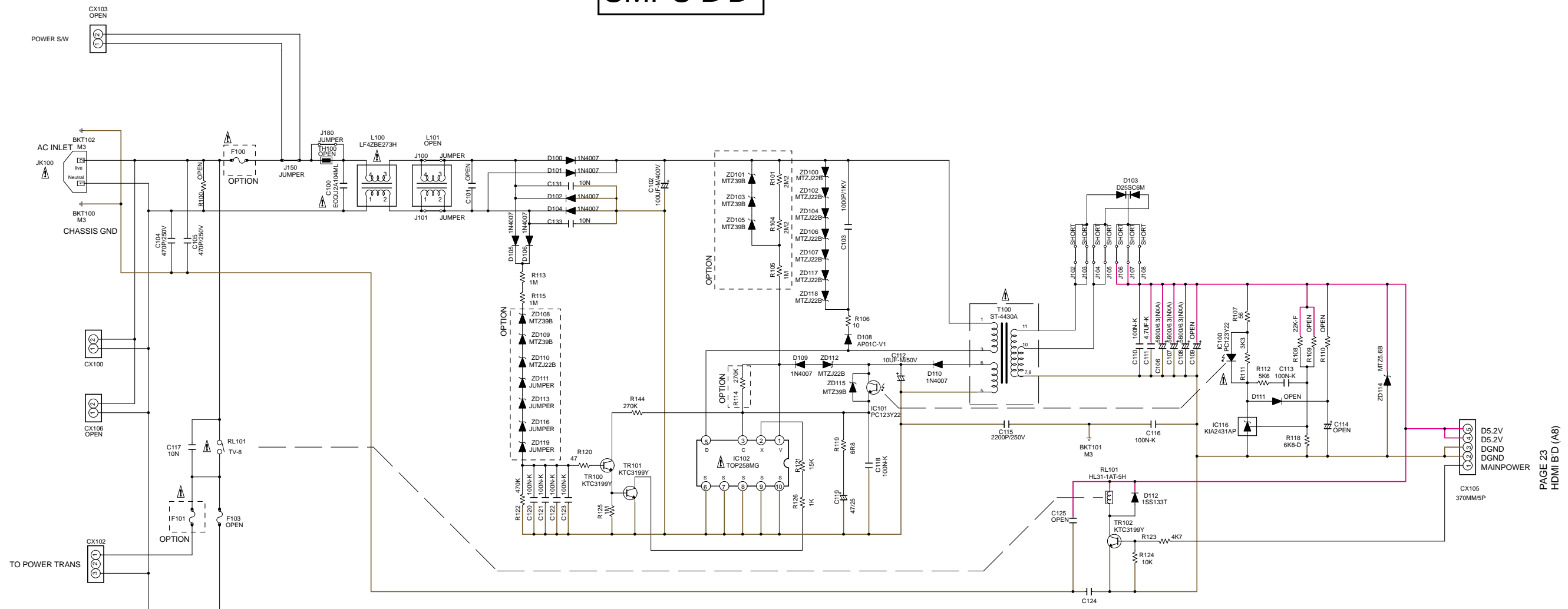

OPTION TABLE

	ZD108	ZD109	ZD110	ZD111	ZD113	ZD116	ZD119	ZD101	ZD103	ZD105	R101	R104	R105	R114	F100	F101
E3	MTZJ39B	MTZJ39B	MTZJ22B	JUMPER	JUMPER	JUMPER	JUMPER	MTZJ39B	MTZJ39B	MTZJ39B	2M2(5)	2M2(5)	1M(5)	270K	2A	6.3A
E2,EA	1M (5)	1M (5)	MTZJ39B	MTZJ39B	MTZJ39B	MTZJ39B	MTZJ39B	OPEN	OPEN	OPEN	OPEN	OPEN	56K	1.6A	3.15A	
JP	MTZJ39B	MTZJ39B	JUMPER	JUMPER	JUMPER	JUMPER	JUMPER	MTZJ39B	MTZJ39B	MTZJ39B	2M2(5)	2M2(5)	1M(5)	270K	2A	6.3A
E1C	1M (5)	1M (5)	MTZJ39B	MTZJ39B	MTZJ39B	MTZJ39B	MTZJ39B	OPEN	OPEN	OPEN	OPEN	OPEN	56K	1.6A	3.15A	

PAGE 23
HDMI B'D (A8)

REG_SIRIUS_COMMON CNT 1/3

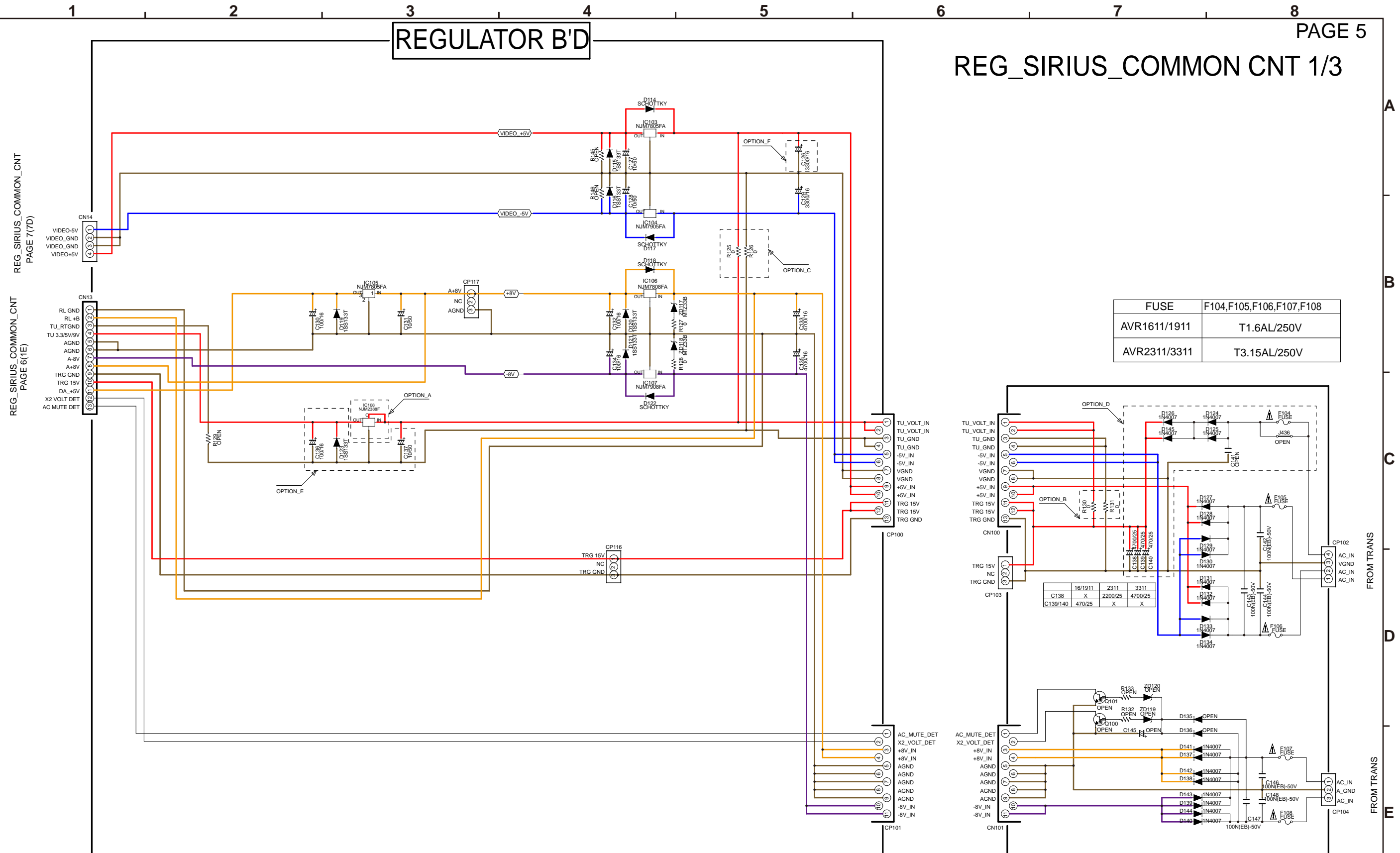

FUSE	F104,F105,F106,F107,F108
AVR1611/1911	T1.6AL/250V
AVR2311/3311	T3.15AL/250V

	16/1911	2311	3311
C138	X	2200/25	4700/25
C139/140	470/25	X	X

*OPTION TABLE

MODEL	AVR1611/1621		AVR1911		AVR591/791		AVR2311/3311		AVR891/991
AREA	E3	E1C/E2/JP	E3	E1C/E2/JP	E3	EA	E3	E1C/E2/JP	E3/EA
OPTION_A	NJM2388F05	NJM2388F09	OPEN	NJM2388F09	NJM2388F05	NJM2388F09	OPEN	NJM2388F09	NJM2388F09
OPTION_B	NOT USE	USE	NOT USE	USE	NOT USE	USE	NOT USE	USE	USE
OPTION_C	USE	NOT USE	USE	NOT USE	USE	NOT USE	NOT USE	NOT USE	NOT USE
OPTION_D	NOT USE	USE	NOT USE	USE	NOT USE	USE	USE	USE	USE
OPTION_E	USE	USE	NOT USE	USE	USE	USE	NOT USE	USE	USE
OPTION_F	4700/16	3300/16	3300/16	3300/16	4700/16	3300/16	3300/16	3300/16	3300/16

SIDE CONNECTOR

REG_SIRIUS_COMMON_CNT 2/3

OPTION A				OPTION B			
MODEL	E3	E2	JP	MODEL	E3	E2	JP
AVR1611	X	X	X	AVR1611	X	X	X
AVR1911	O	X	X	AVR1911	O	X	X
AVR2311	O	X	X	AVR2311	O	X	X
AVR3311	O	X	X	AVR3311	O	X	X

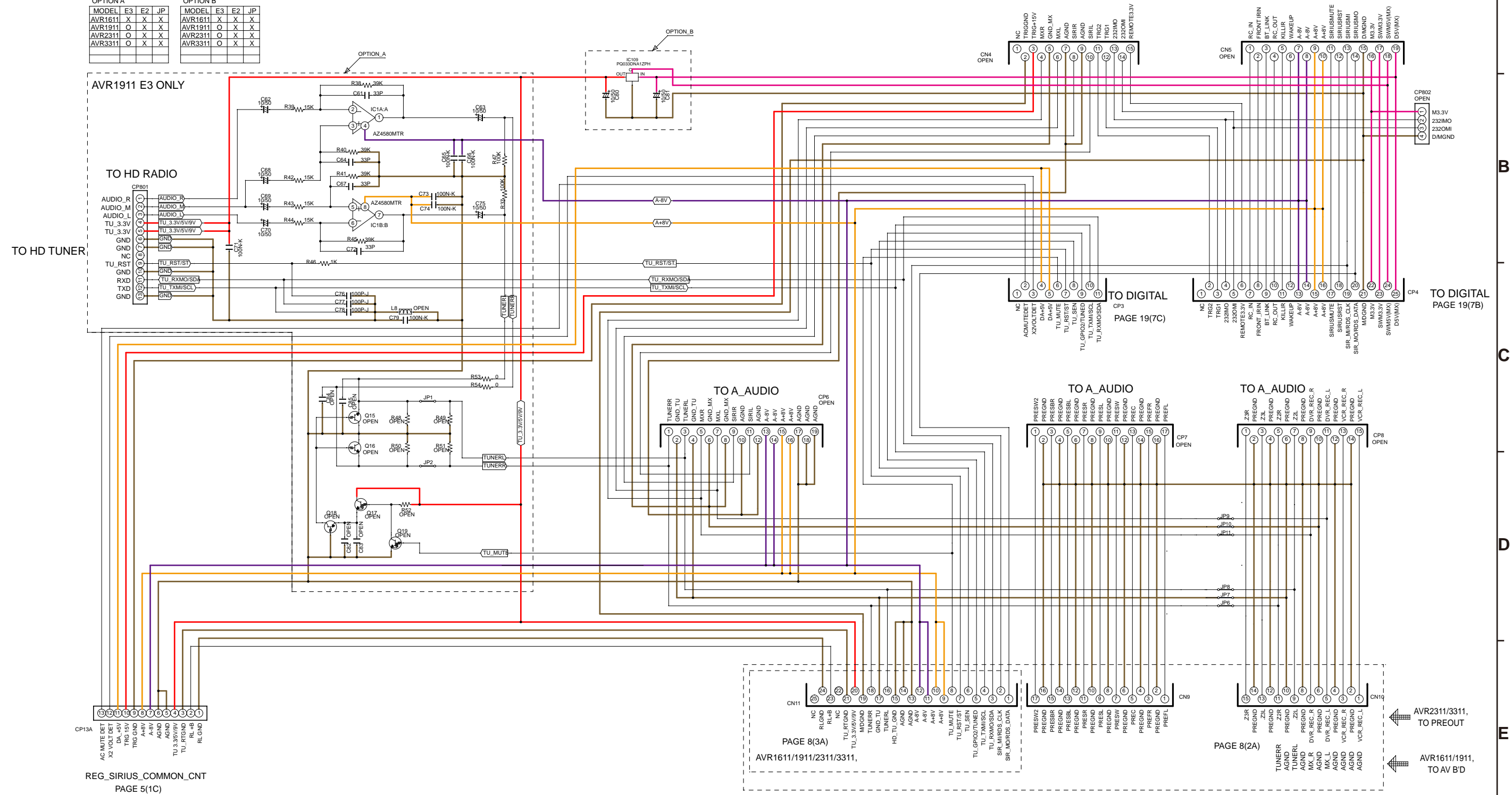

REG_SIRIUS_COMMON_CNT
PAGE 5(1C)

AVR1611/1911/2311/3311,
PAGE 8(3A)

PAGE 8(2A)

AVR2311/3311,
TO PREOUT

AVR1611/1911,
TO AV BD

FRONT CONNECTOR

REG_SIRIUS_COMMON CNT 3/3

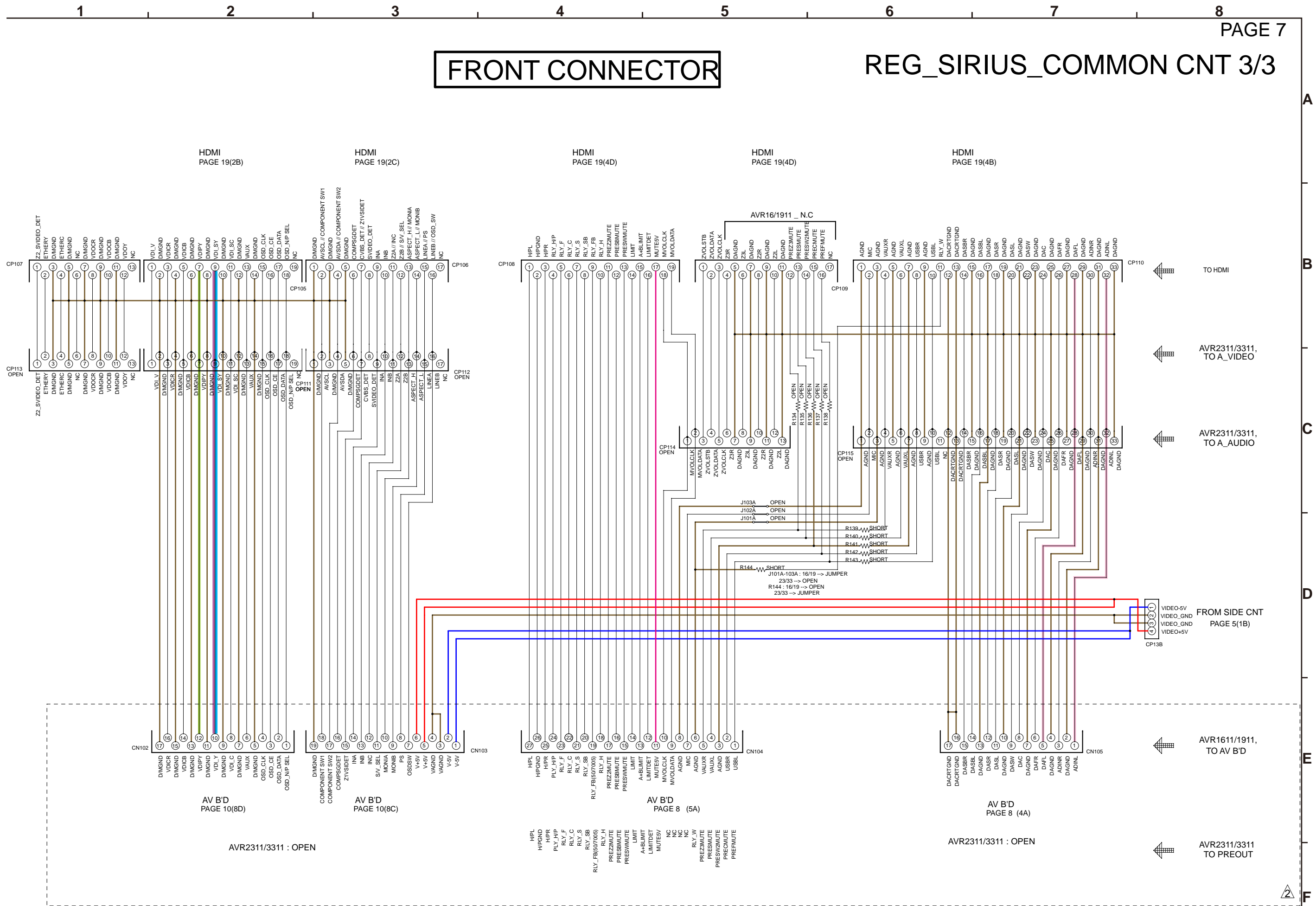

AVR2311/3311 : OPEN

AVR2311/3311 : OPEN

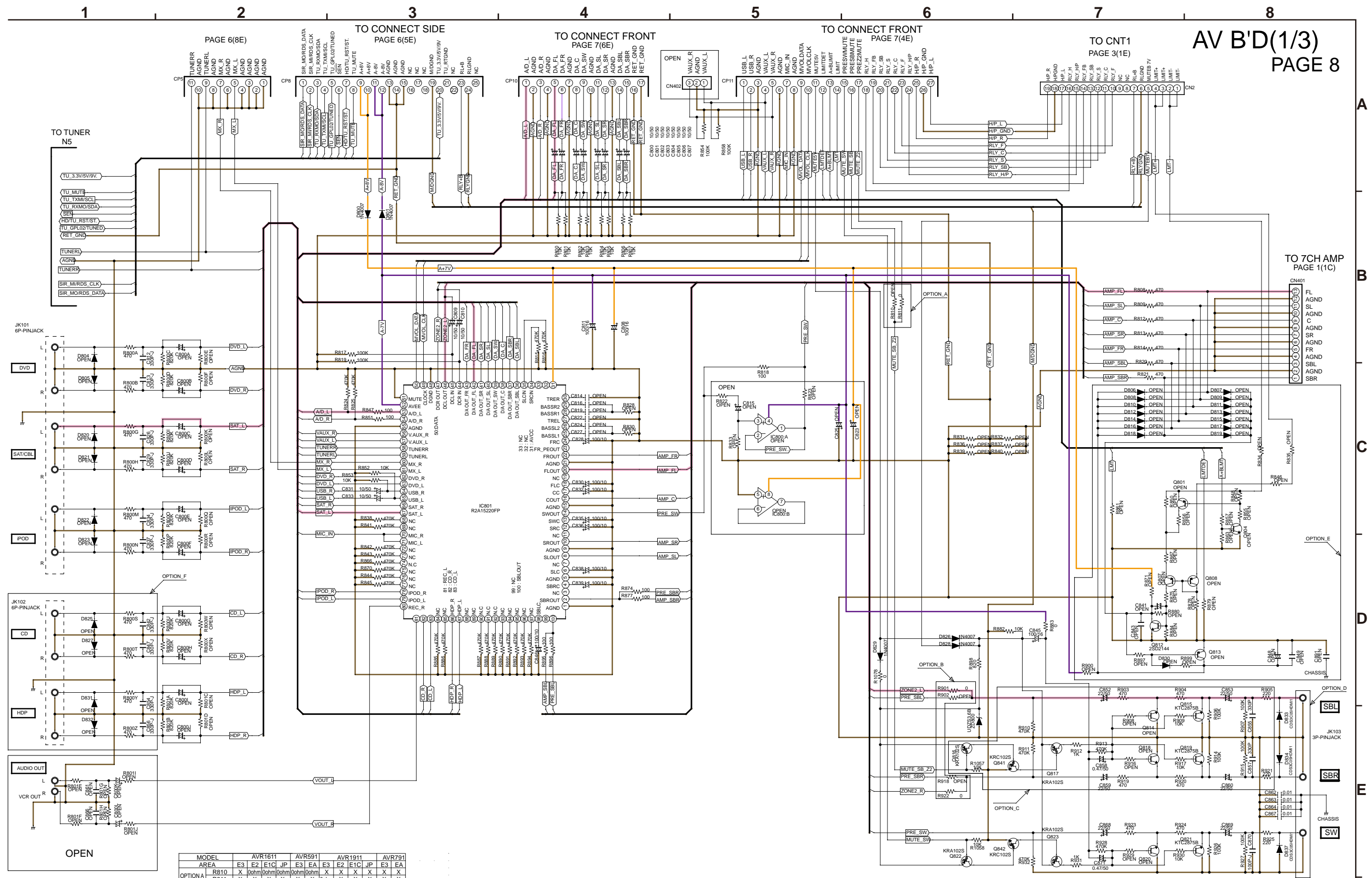

MODEL	AVR1611	AVR591	AVR1911	AVR791
AREA	E3	E2	E1C	JP
OPTION A	R810	X	0ohm	0ohm
OPTION B	R902	X	0ohm	0ohm
OPTION C	R922	X	0	0
OPTION D	JK103	1P	3P	3P
OPTION E		X	X	X
OPTION F		X	X	X

AV B'D(2/3)

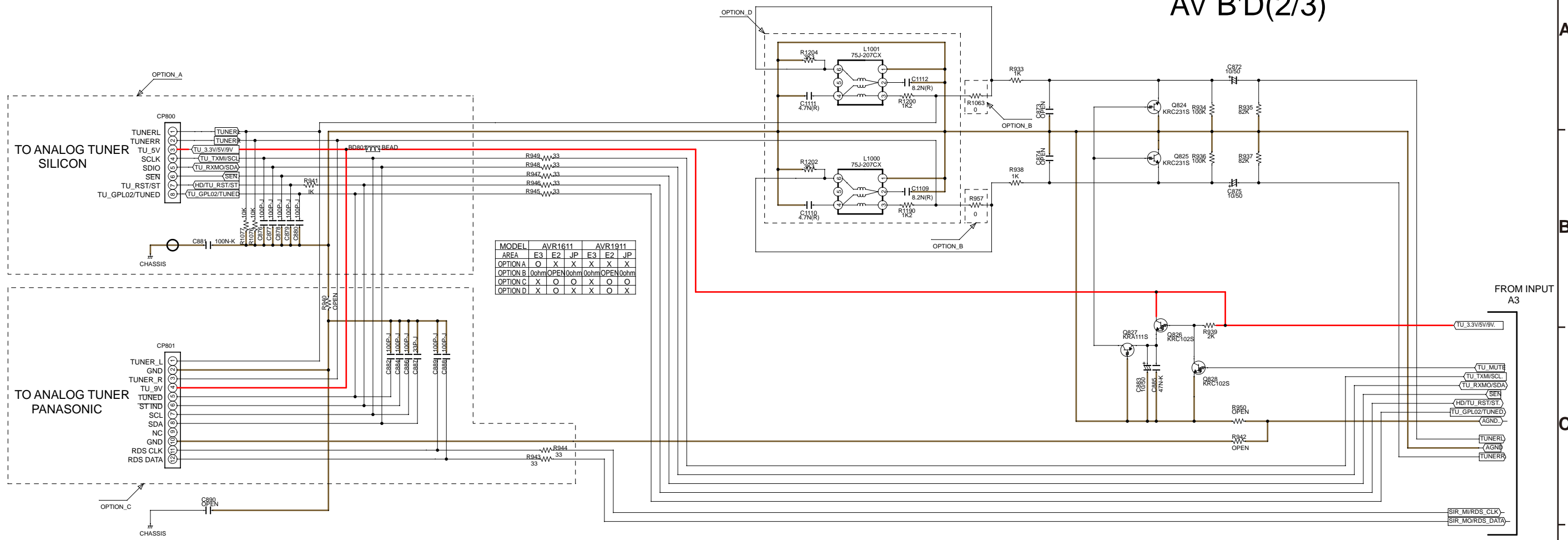

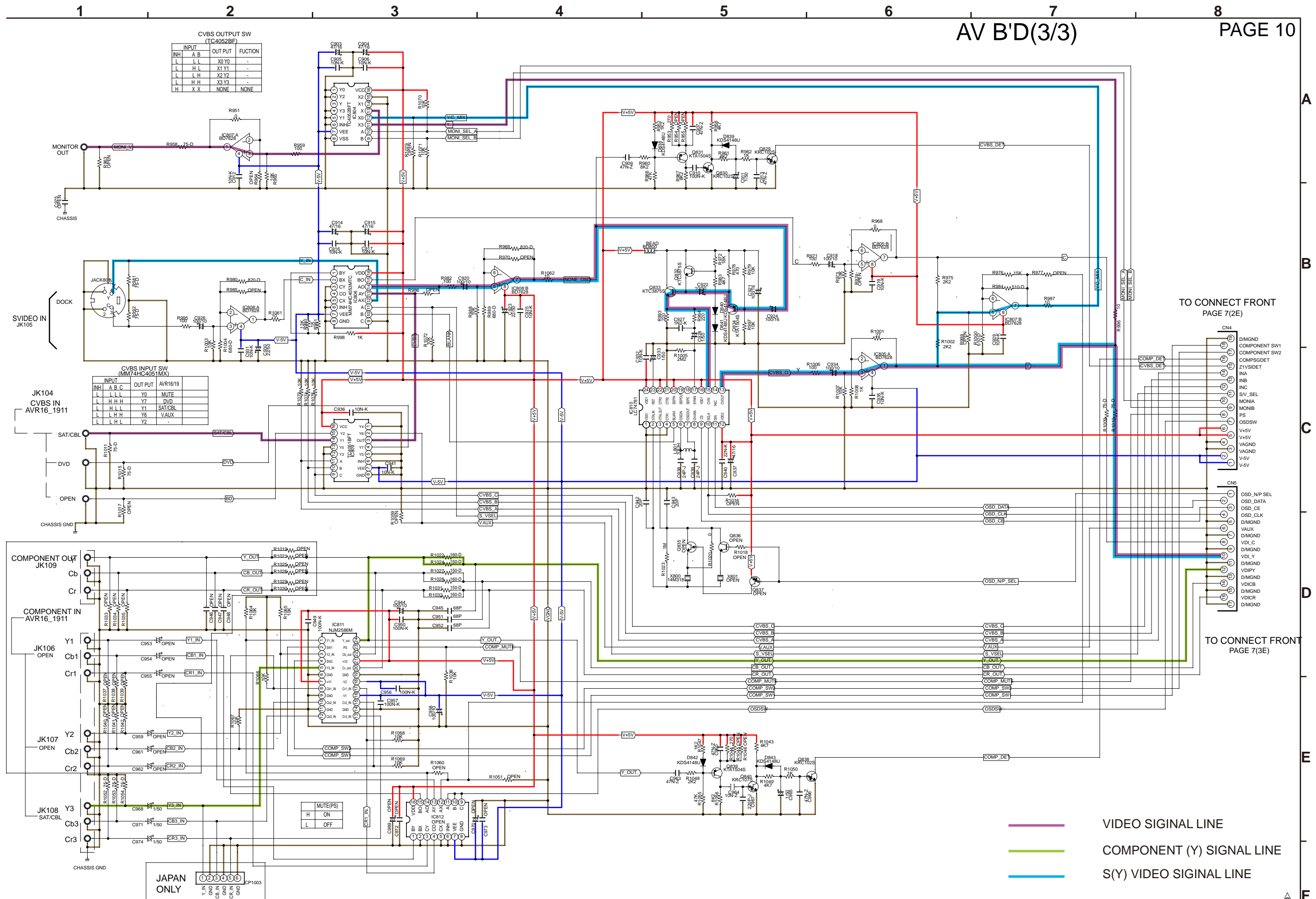

SCHEMATIC DIAGRAMS (10/23)

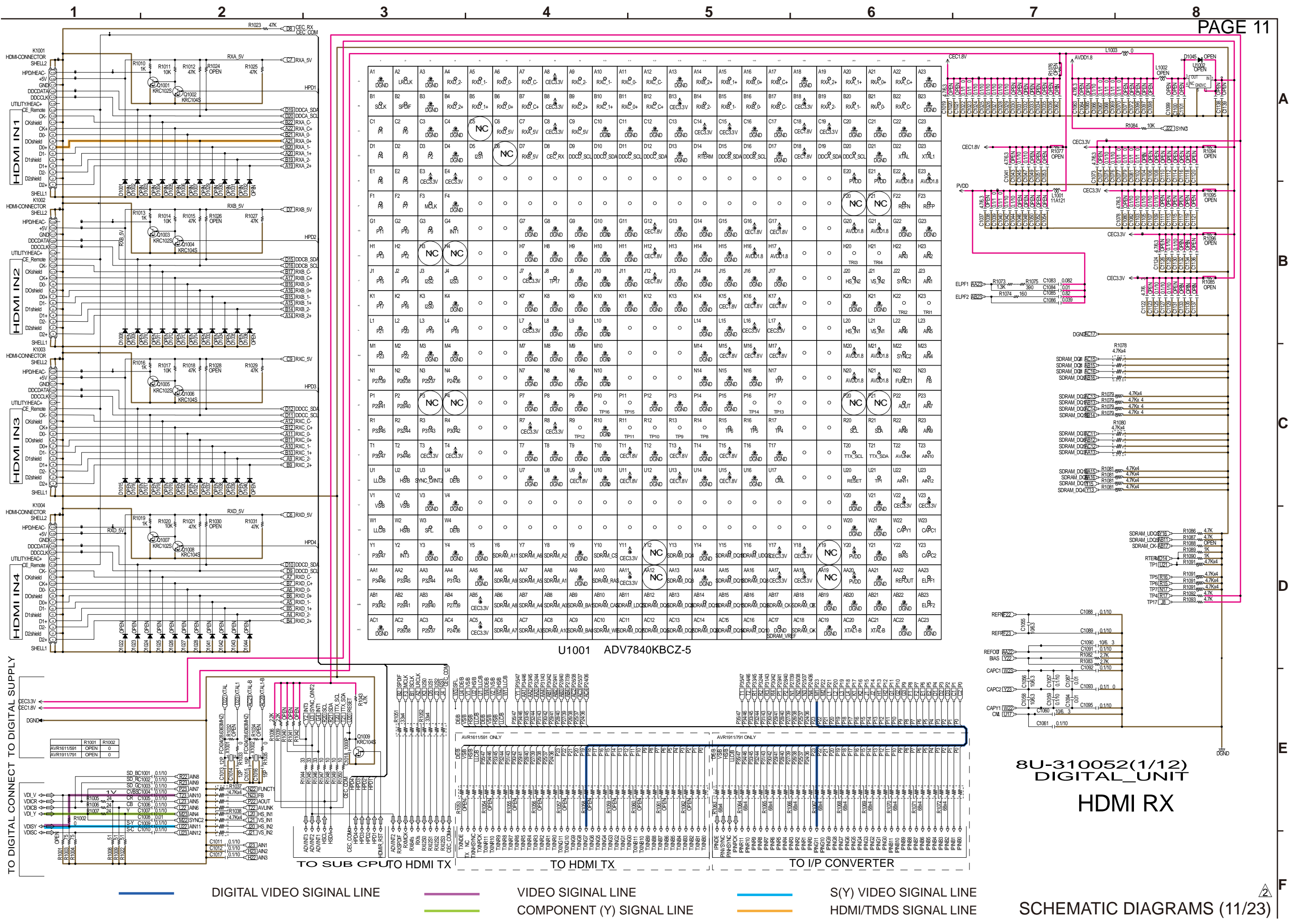

DIGITAL VIDEO SIGNAL LINE
 VIDEO SIGNAL LINE
 S(Y) VIDEO SIGNAL LINE
 COMPONENT (Y) SIGNAL LINE
 HDMI/TMDS SIGNAL LINE
 SCHEMATIC DIAGRAMS (11/23)

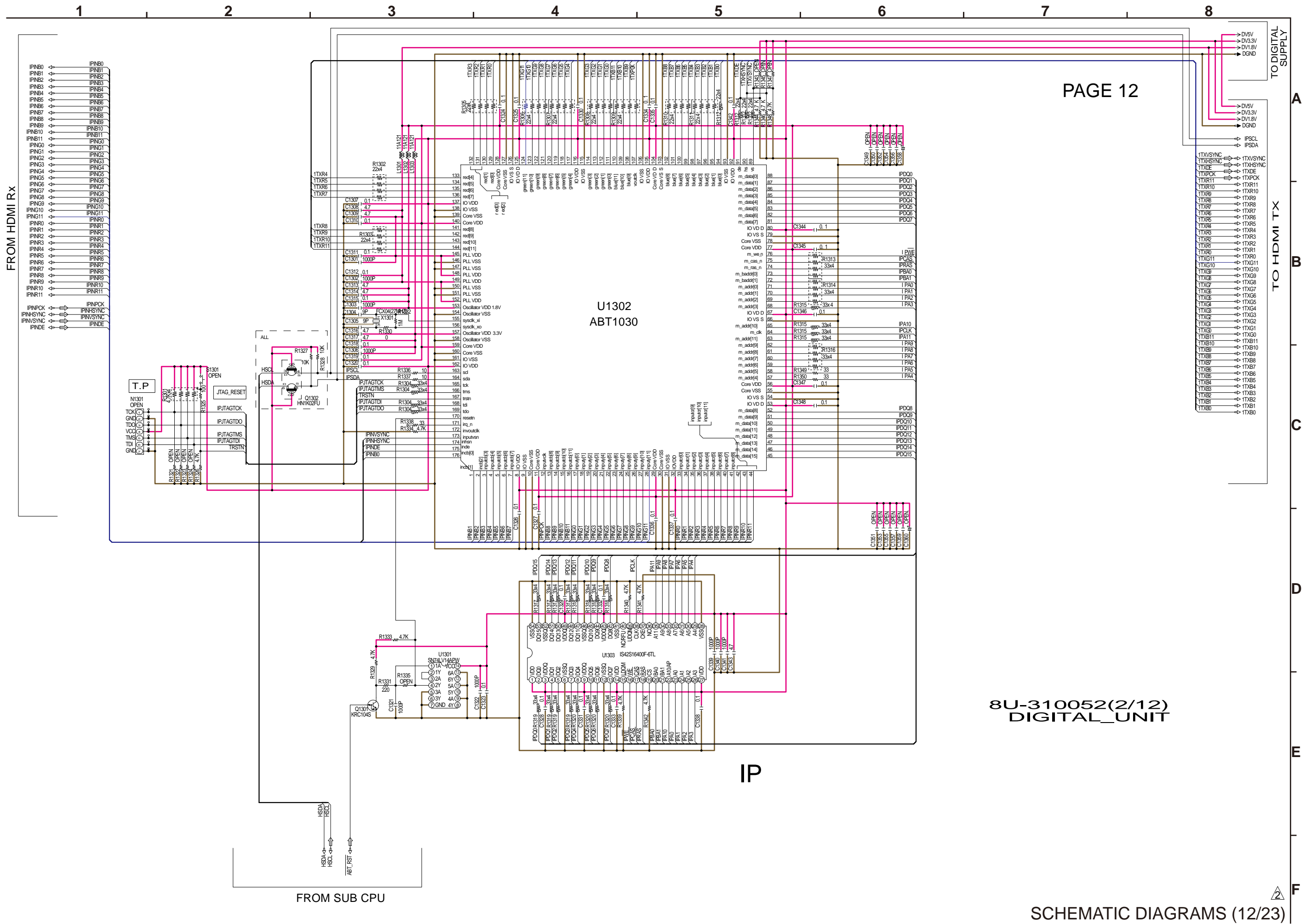

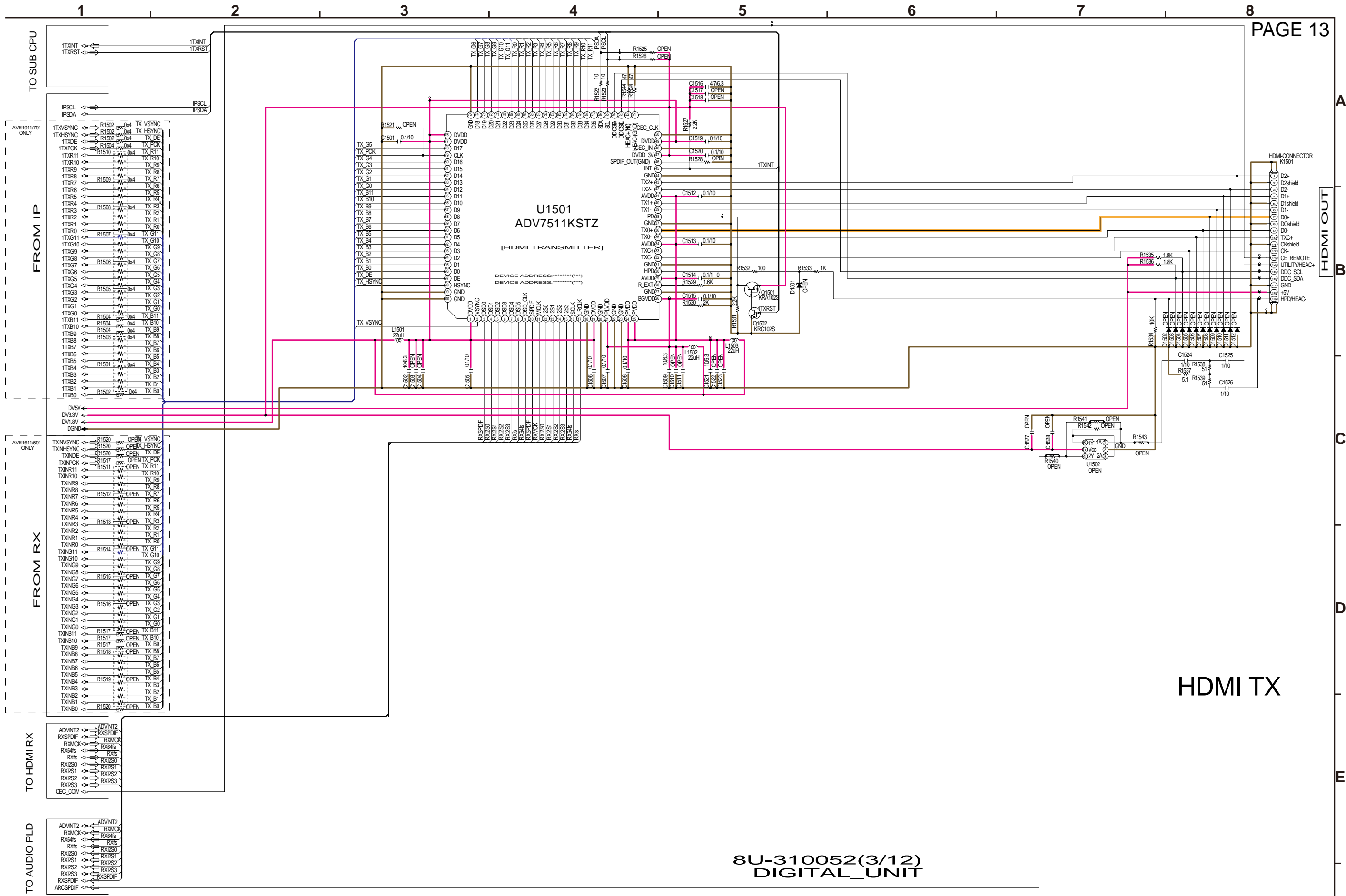

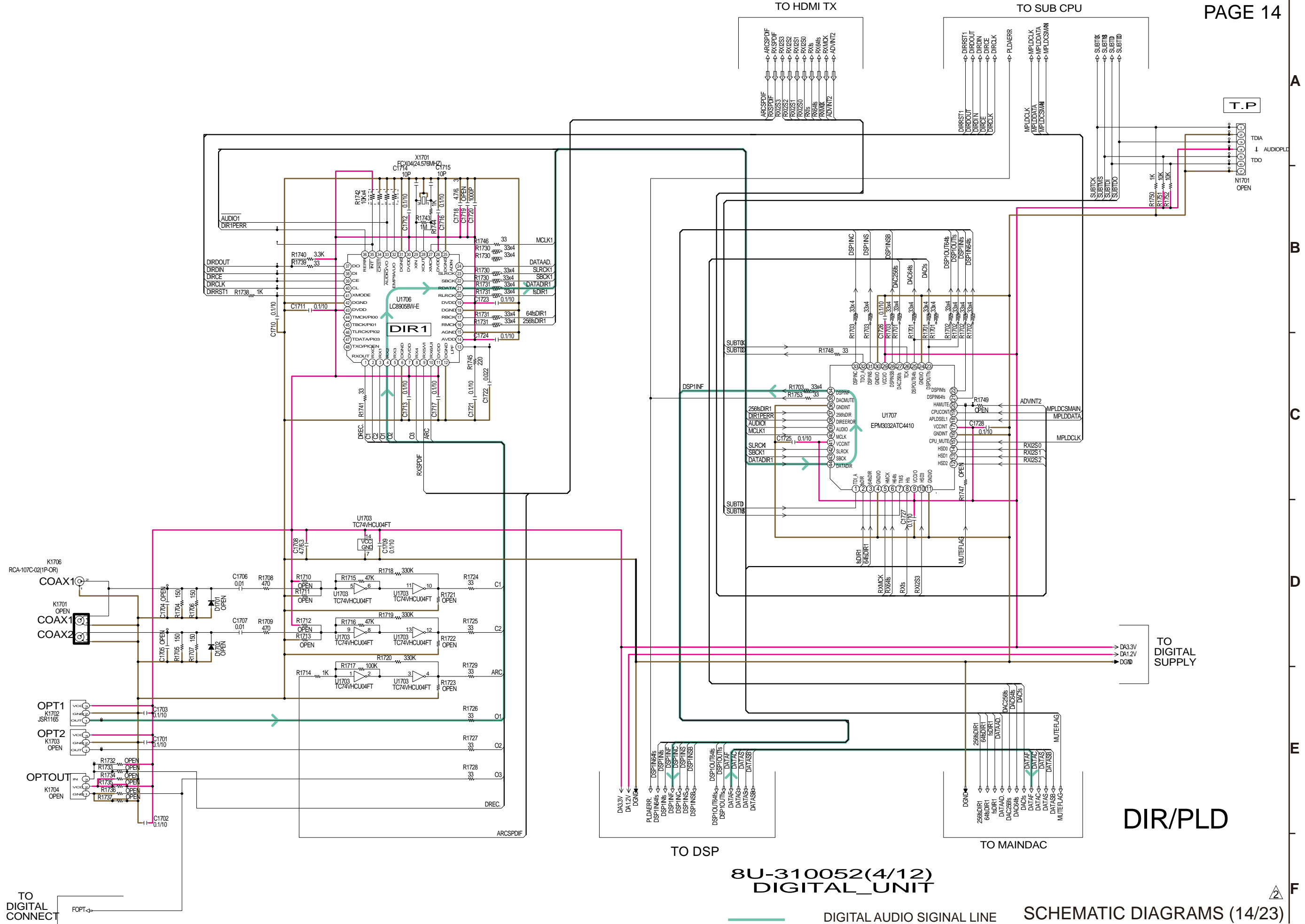

8U-310052(4/12) DIGITAL_UNIT

— DIGITAL AUDIO SIGNAL LINE SCHEMATIC DIAGRAMS (14/23)

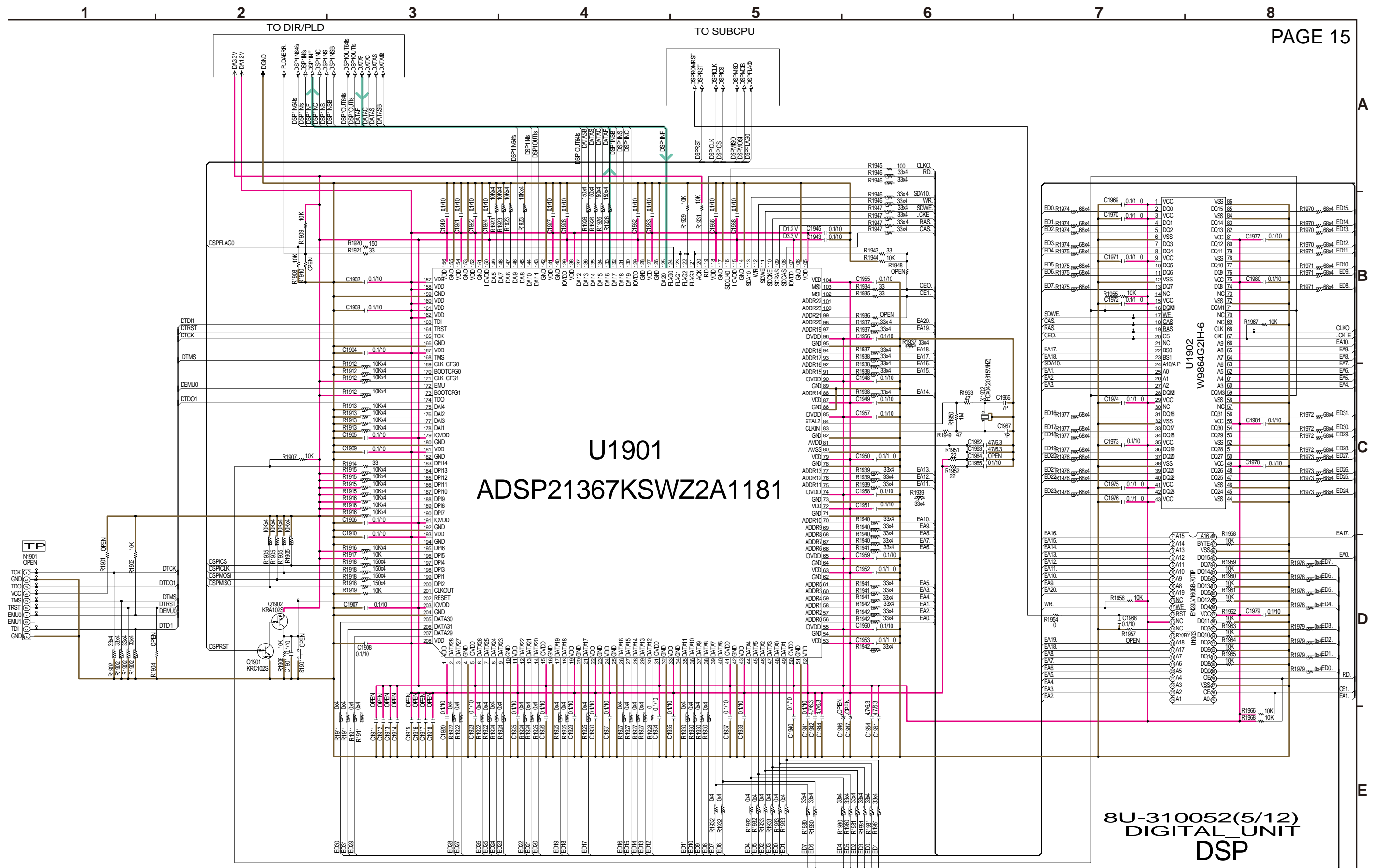

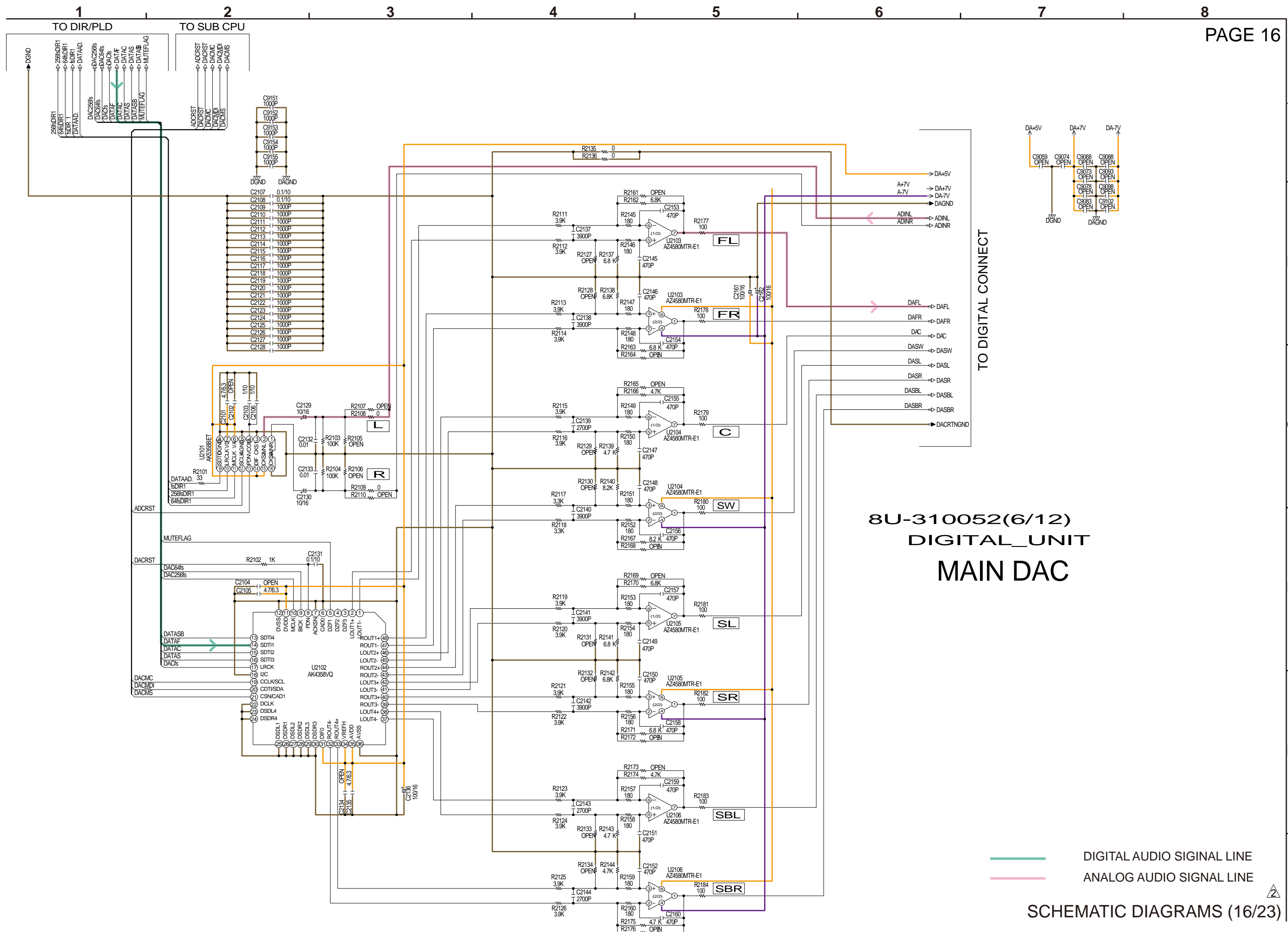

— DIGITAL AUDIO SIGNAL LINE
— ANALOG AUDIO SIGNAL LINE
 SCHEMATIC DIAGRAMS (16/23)

USB TCC8600 AVR1911/791 ONLY

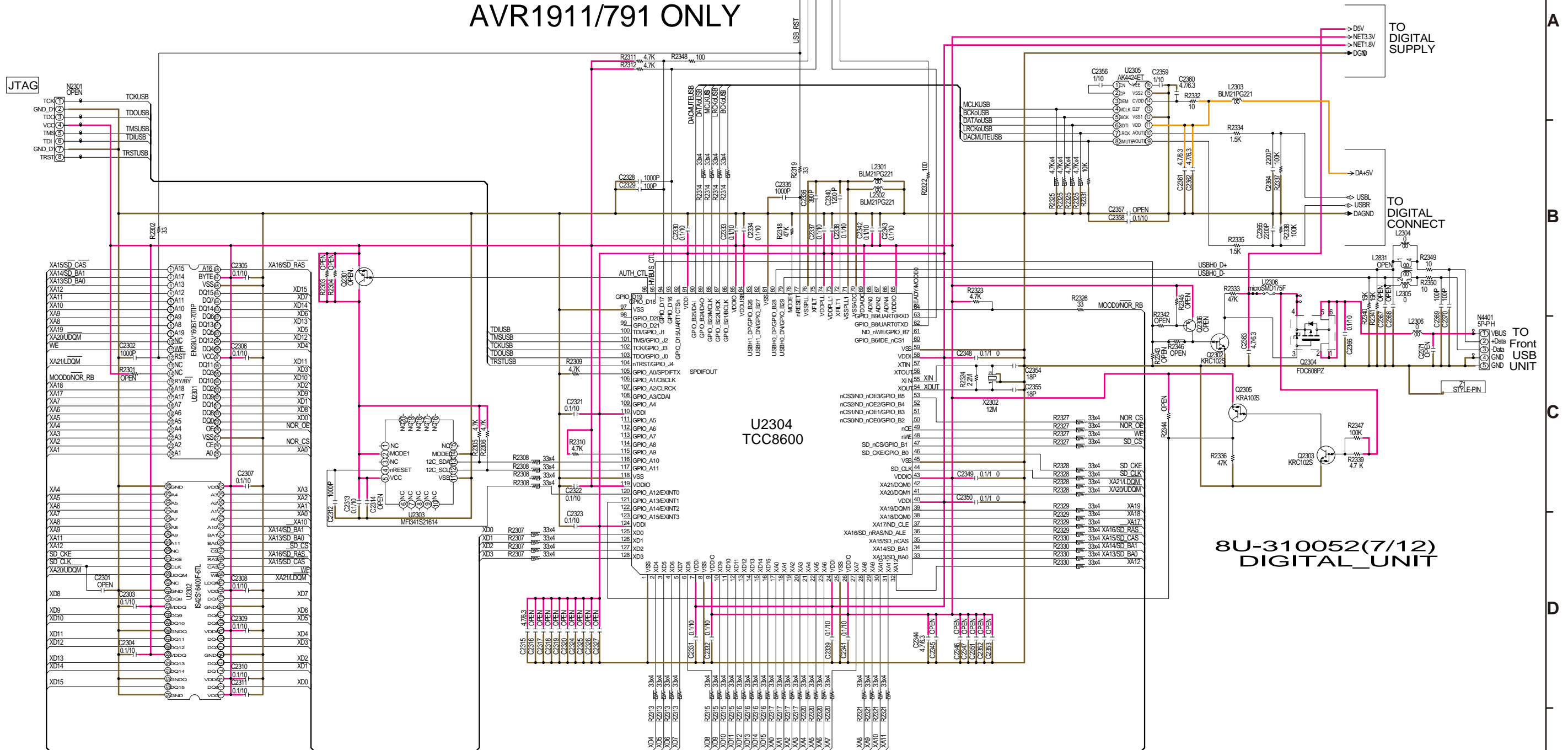

8U-310052(7/12)
DIGITAL_UNIT

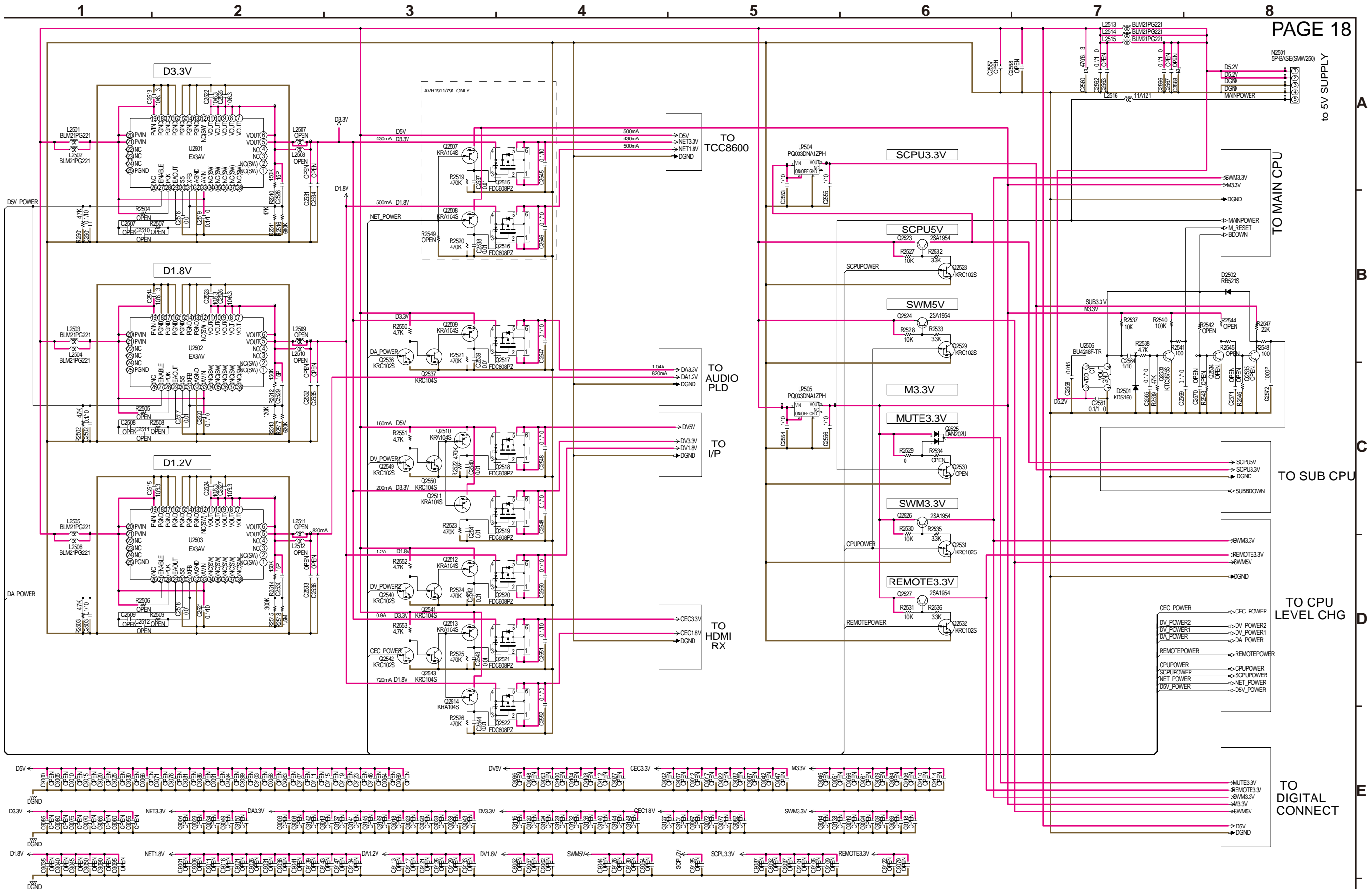

8U-310052(8/12)
DIGITAL UNIT
D.SUPPLY/RESET

EMI FILTER MP=PATARN SHORT

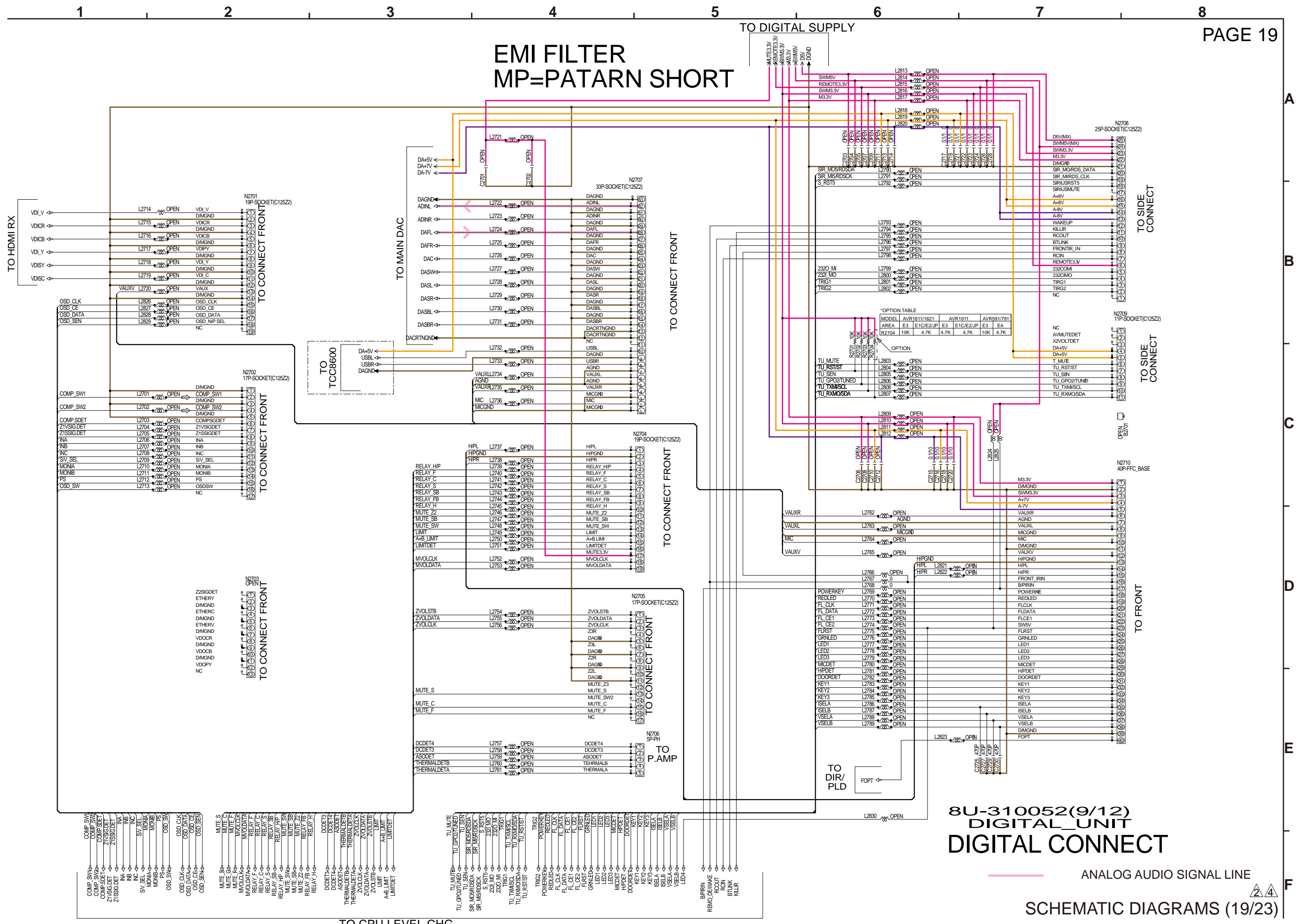

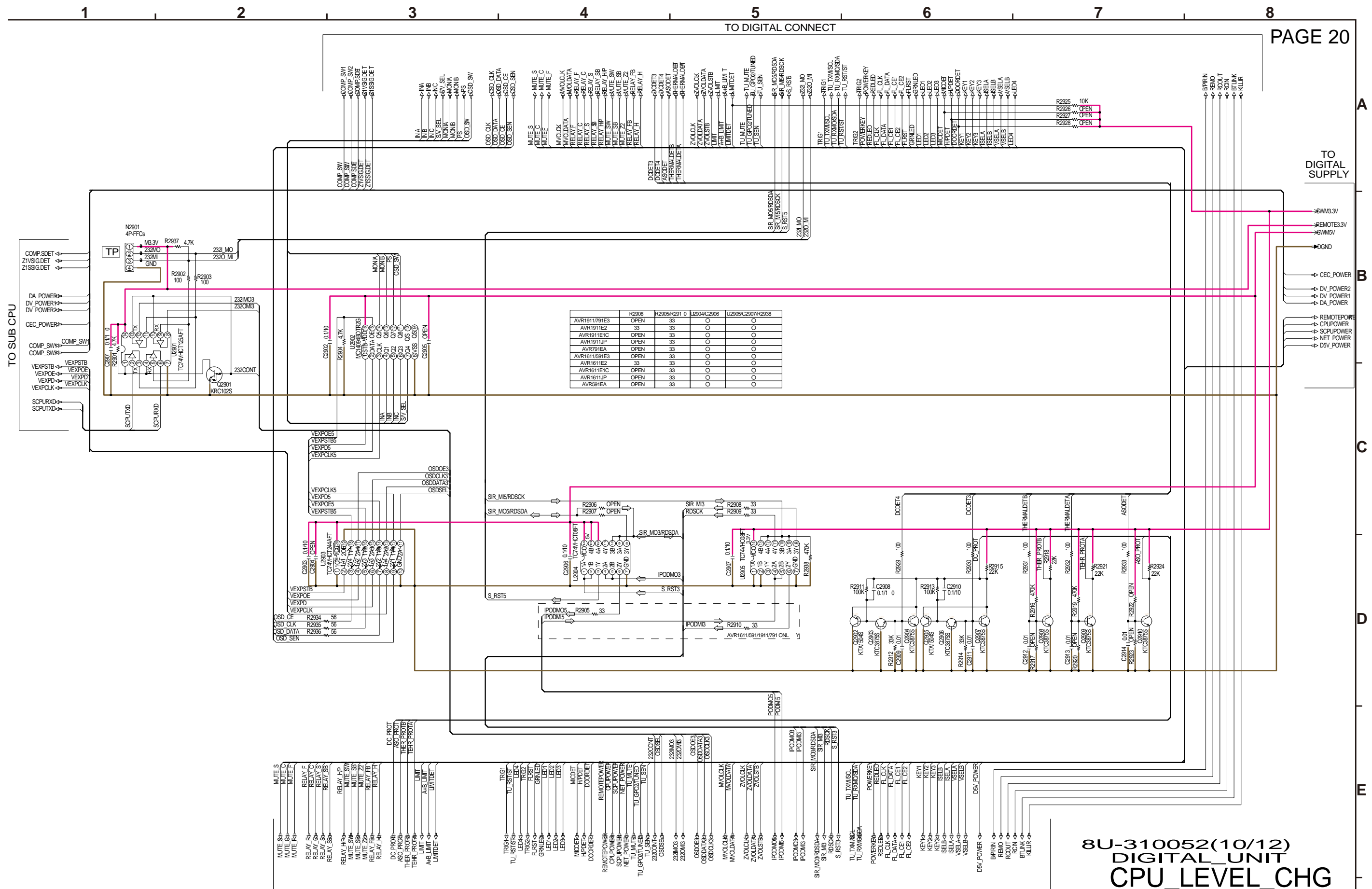

8U-310052(10/12)
 DIGITAL_UNIT
 CPU_LEVEL_CHG

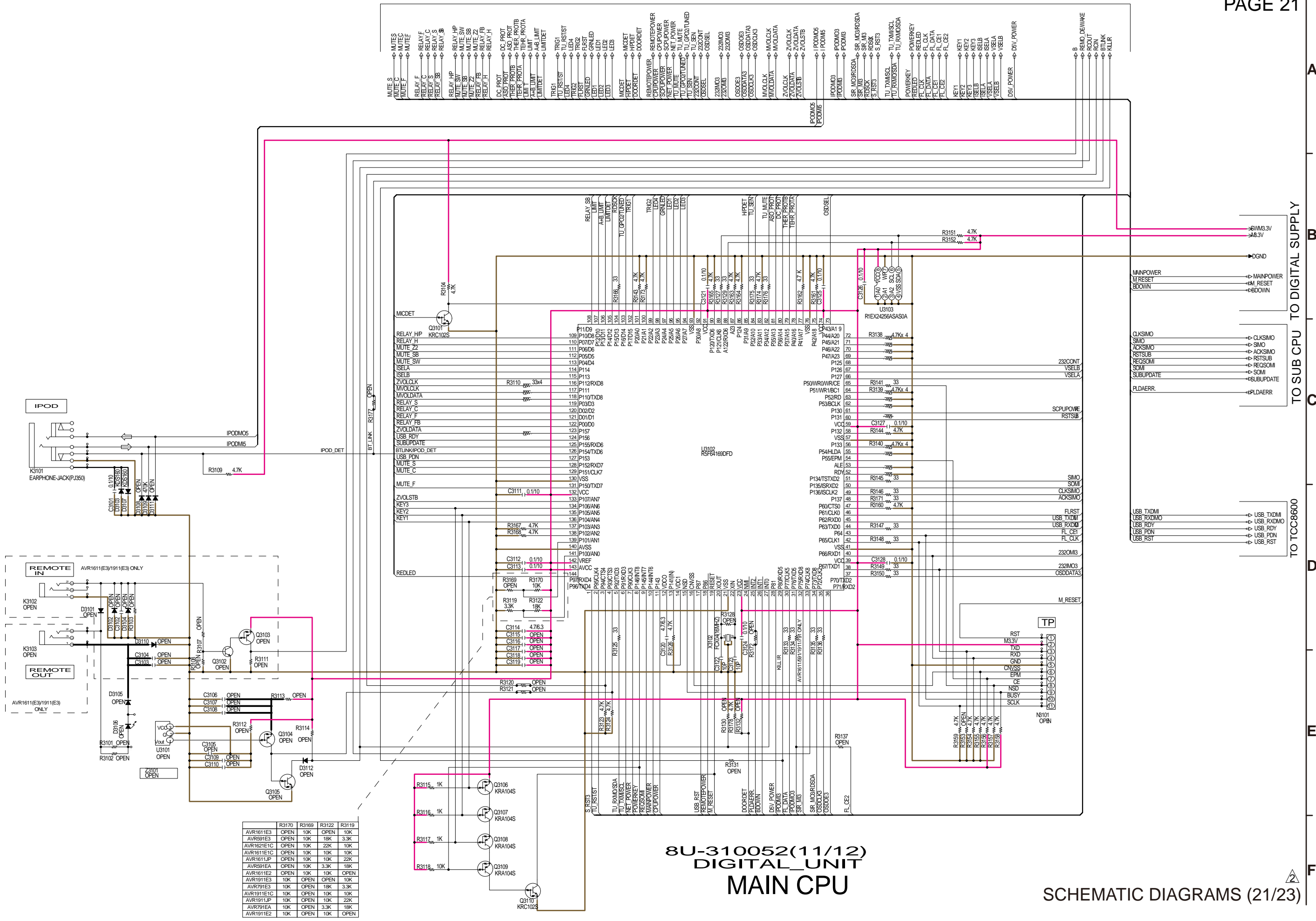

8U-310052(11/12)
DIGITAL_UNIT
MAIN CPU

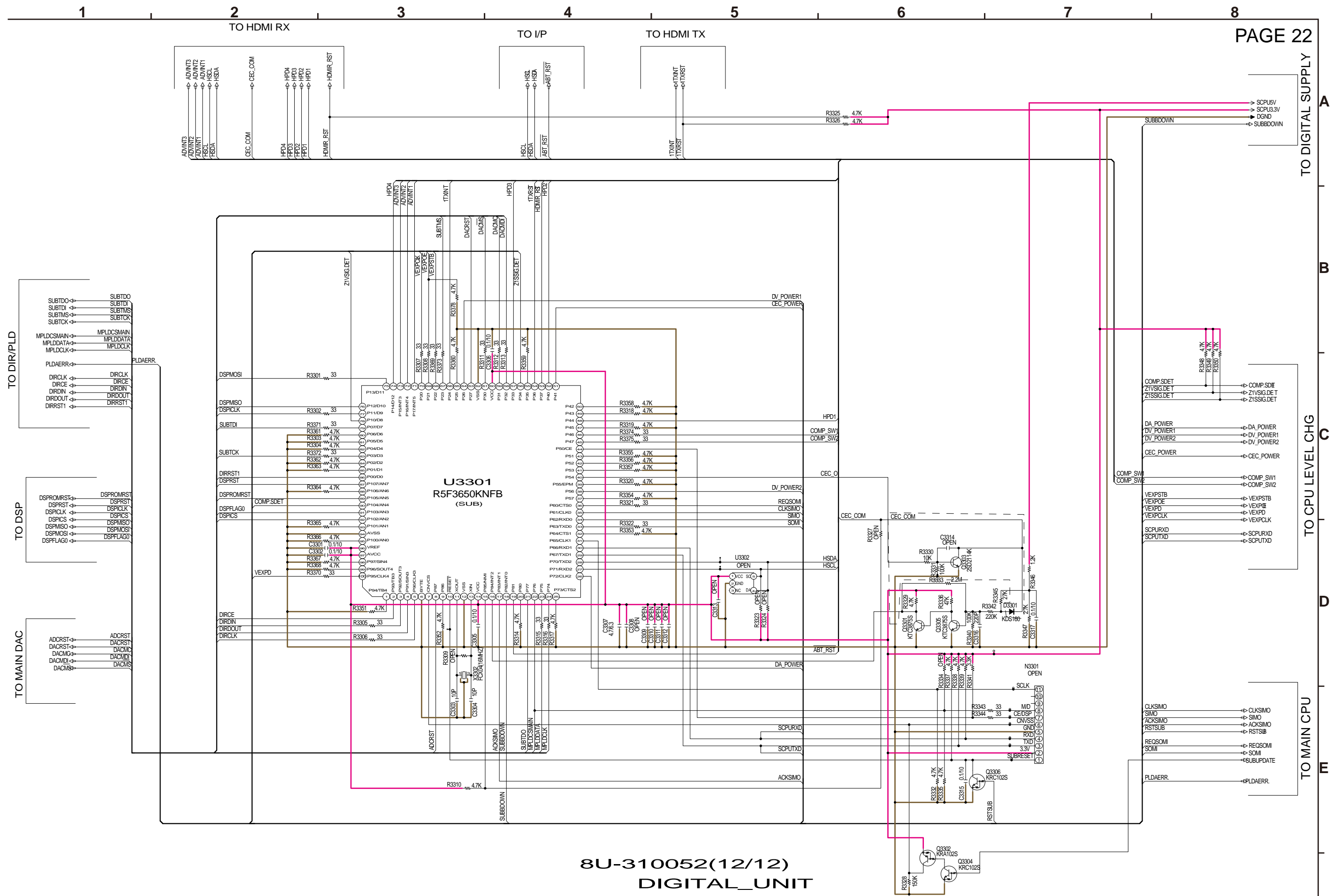

8U-310052(12/12)
DIGITAL_UNIT

FRONT 1/1

BLOCK	R-NO	AVR16/1911	AVR2311
A	R107/R108 R115/R117 R116/R118 Q107/Q108	100 100K 39K KTC3875S	NOT USE
B	R105/H12 R102/Q14 R120/123 R131/132 C102	100 0 OPEN OPEN 100K	200 0 1/2.2 OPEN 100K
C	C144 C145	1/50 47N-100V	OPEN OPEN
D	C142 C143	47N-100V 1/50	OPEN OPEN
E		NOT USE	USE
F		1uF	OPEN

R-NO	AVR16/1911	AVR2311
D100	1N4007	REVERSE INSERT
D101	1N4007	REVERSE INSERT
D102	1N4007	REVERSE INSERT
D103	1N4007	REVERSE INSERT
D104	1N4007	REVERSE INSERT
D105	1N4007	REVERSE INSERT
D106	1N4007	REVERSE INSERT
D107	1N4007	REVERSE INSERT
D108	1N4007	REVERSE INSERT
D109	1N4007	REVERSE INSERT
D110	1N4007	REVERSE INSERT
D111	1N4007	REVERSE INSERT
D112	1N4007	REVERSE INSERT
D113	1N4007	REVERSE INSERT
D114	1N4007	REVERSE INSERT
D115	1N4007	REVERSE INSERT
D116	1N4007	REVERSE INSERT
D117	1N4007	REVERSE INSERT
D118	1N4007	REVERSE INSERT
D119	1N4007	REVERSE INSERT
D120	1N4007	REVERSE INSERT
D121	1N4007	REVERSE INSERT
D122	1N4007	REVERSE INSERT
D123	1N4007	REVERSE INSERT
D124	1N4007	REVERSE INSERT
D125	1N4007	REVERSE INSERT
D126	1N4007	REVERSE INSERT
D127	1N4007	REVERSE INSERT
D128	1N4007	REVERSE INSERT
D129	1N4007	REVERSE INSERT
D130	1N4007	REVERSE INSERT
D131	1N4007	REVERSE INSERT
D132	1N4007	REVERSE INSERT
D133	1N4007	REVERSE INSERT
D134	1N4007	REVERSE INSERT
D135	1N4007	REVERSE INSERT
D136	1N4007	REVERSE INSERT
D137	1N4007	REVERSE INSERT
D138	1N4007	REVERSE INSERT
D139	1N4007	REVERSE INSERT
D140	1N4007	REVERSE INSERT
D141	1N4007	REVERSE INSERT
D142	1N4007	REVERSE INSERT
D143	1N4007	REVERSE INSERT
D144	1N4007	REVERSE INSERT
D145	1N4007	REVERSE INSERT
D146	1N4007	REVERSE INSERT
D147	1N4007	REVERSE INSERT
D148	1N4007	REVERSE INSERT
D149	1N4007	REVERSE INSERT
D150	1N4007	REVERSE INSERT
D151	1N4007	REVERSE INSERT
D152	1N4007	REVERSE INSERT
D153	1N4007	REVERSE INSERT
D154	1N4007	REVERSE INSERT
D155	1N4007	REVERSE INSERT
D156	1N4007	REVERSE INSERT
D157	1N4007	REVERSE INSERT
D158	1N4007	REVERSE INSERT
D159	1N4007	REVERSE INSERT
D160	1N4007	REVERSE INSERT
D161	1N4007	REVERSE INSERT
D162	1N4007	REVERSE INSERT
D163	1N4007	REVERSE INSERT
D164	1N4007	REVERSE INSERT
D165	1N4007	REVERSE INSERT

R-NO	AVR16/19/2311	AVR991
R174	OPEN	330
R173	OPEN	10K
C167	OPEN	10N-K
LED104	OPEN	SEL5020J
Q114	OPEN	KRC102S

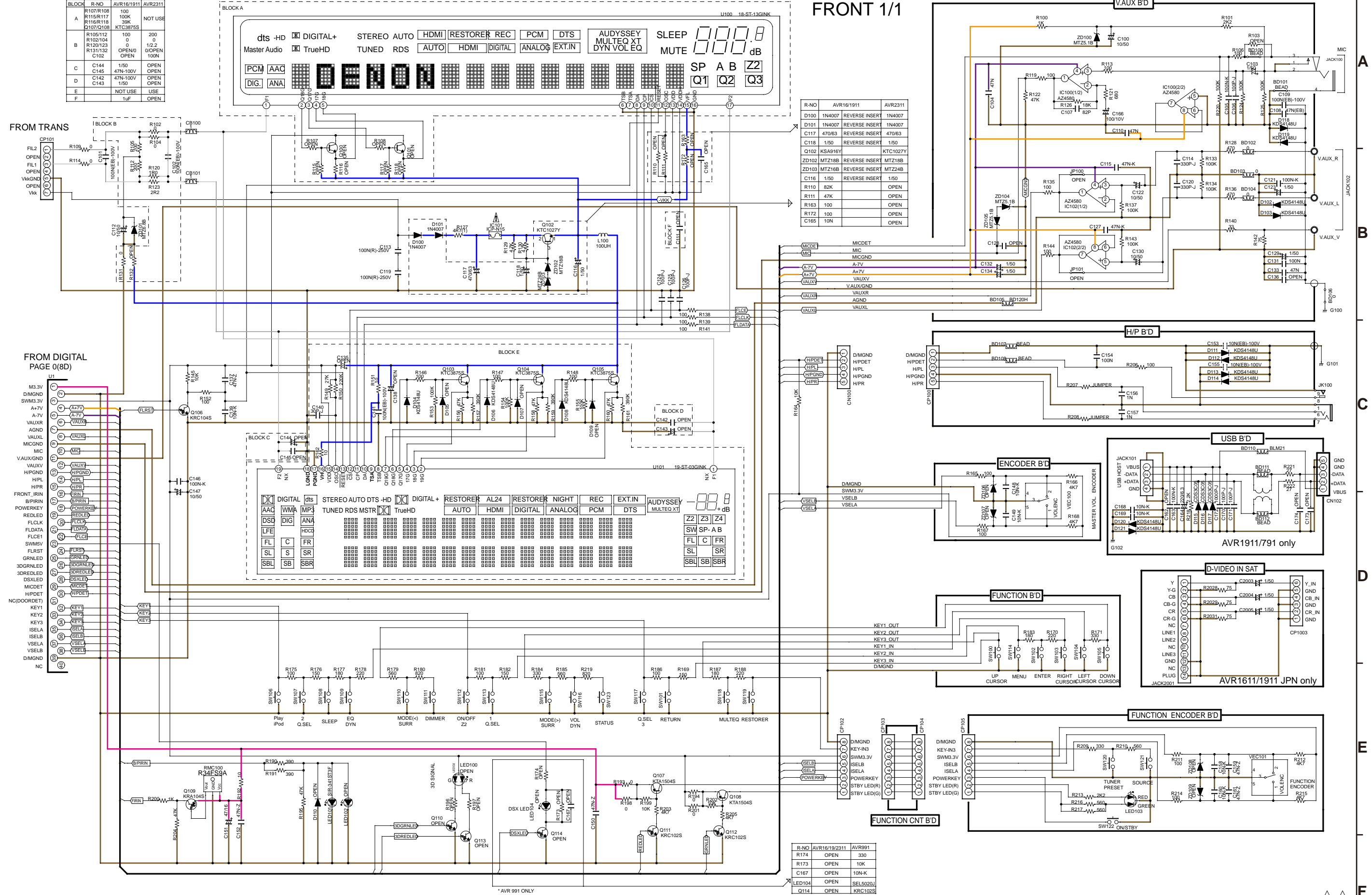

WIRING DIAGRAM

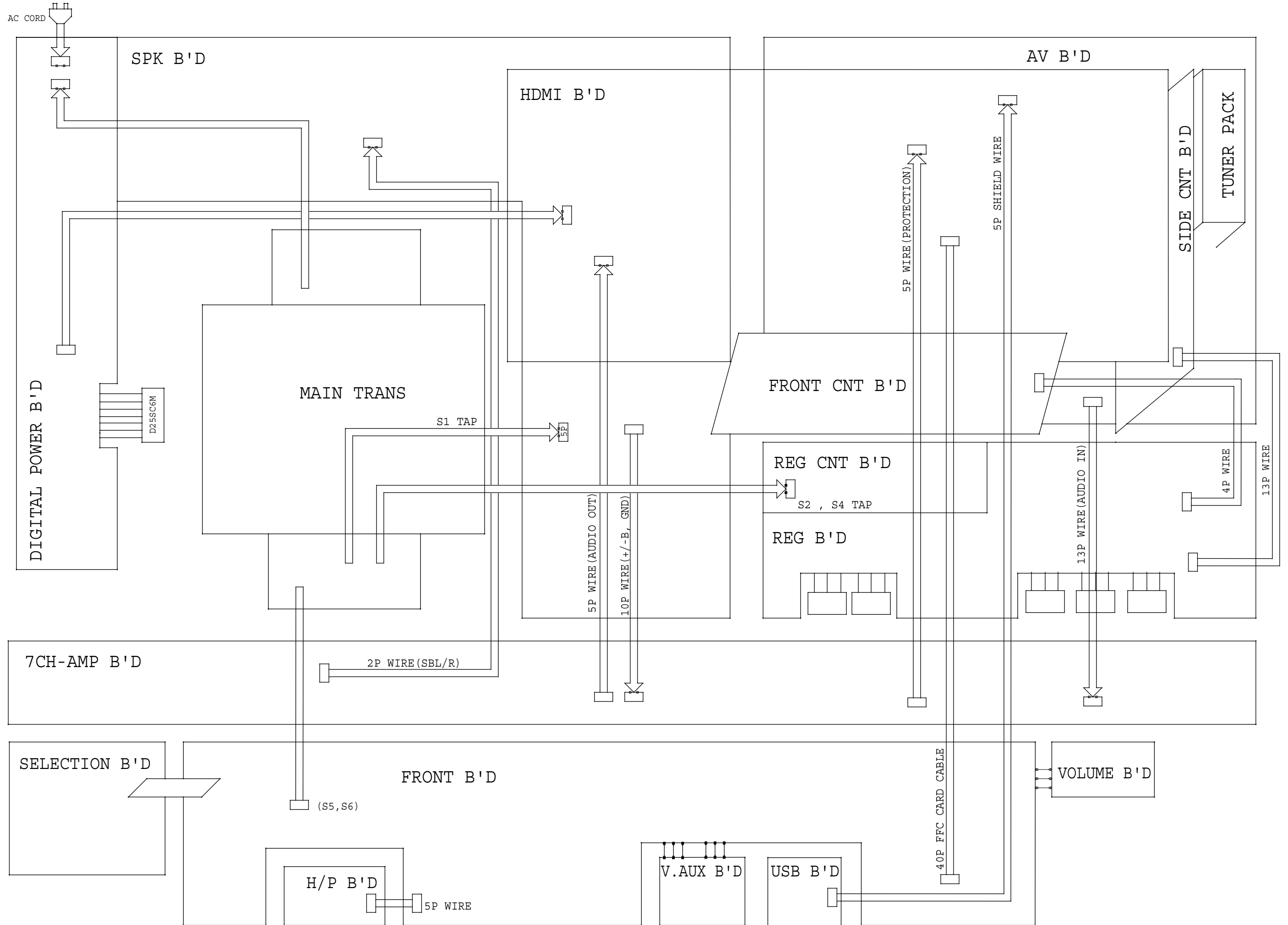

EXPLODED VIEW 

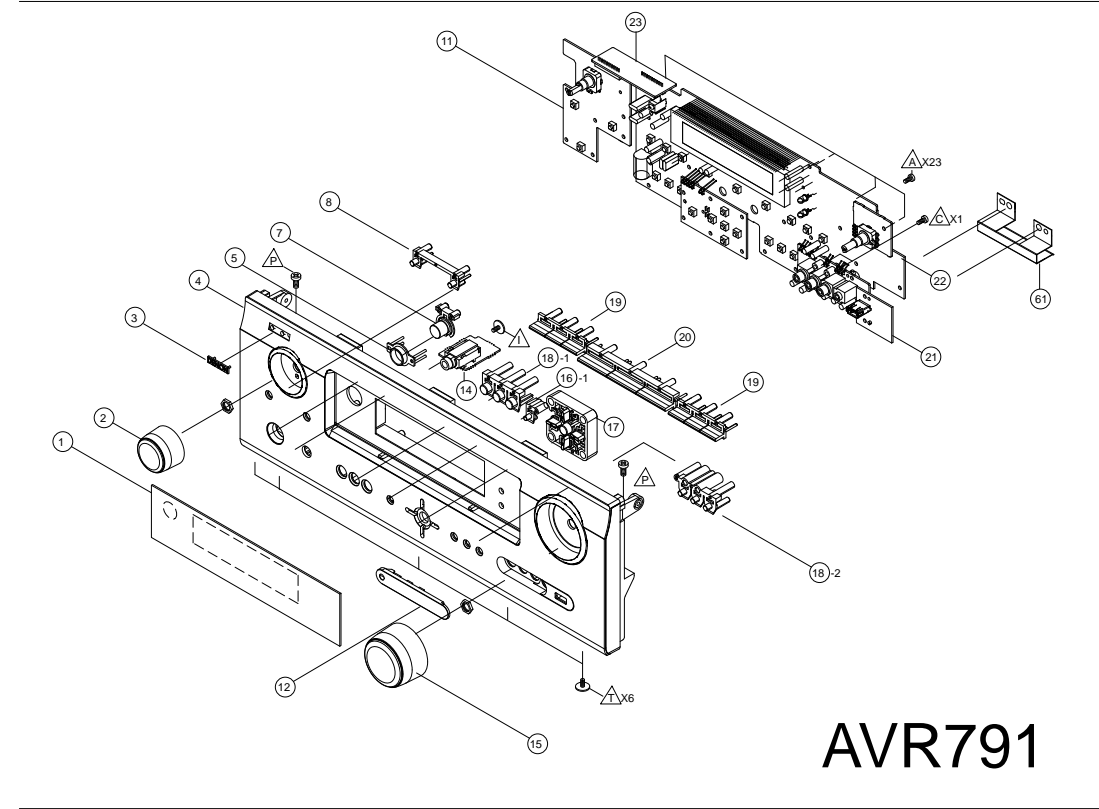

AVR791

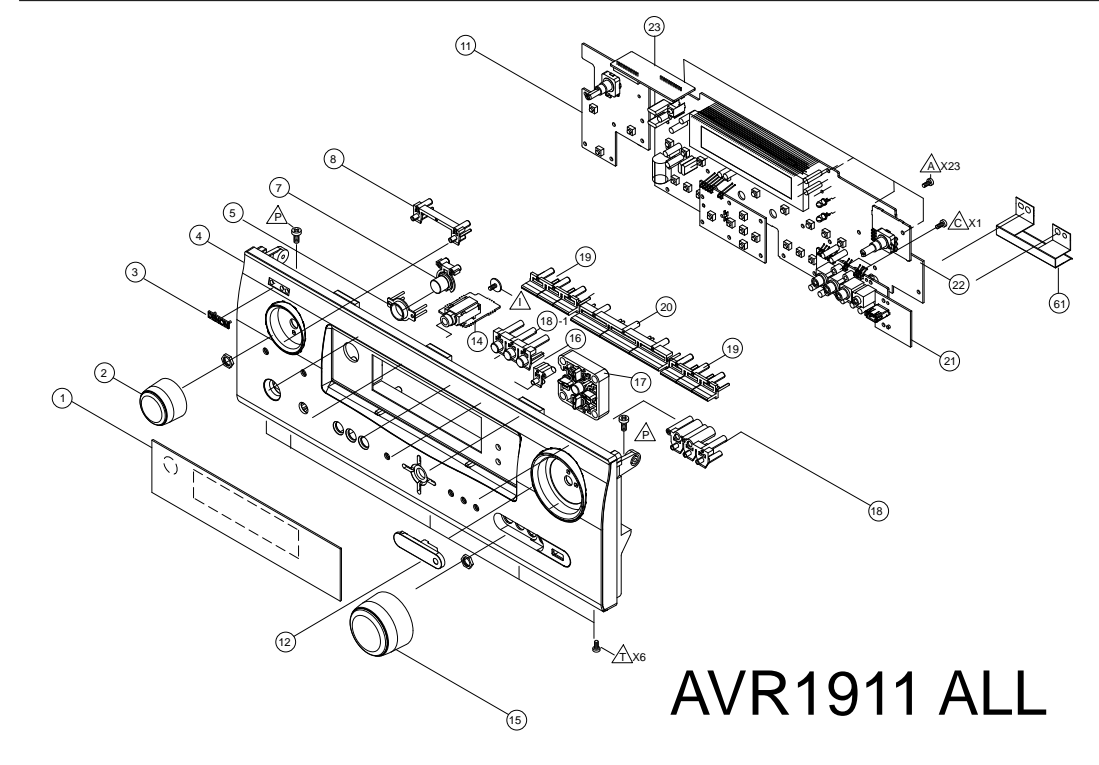

AVR1911 ALL

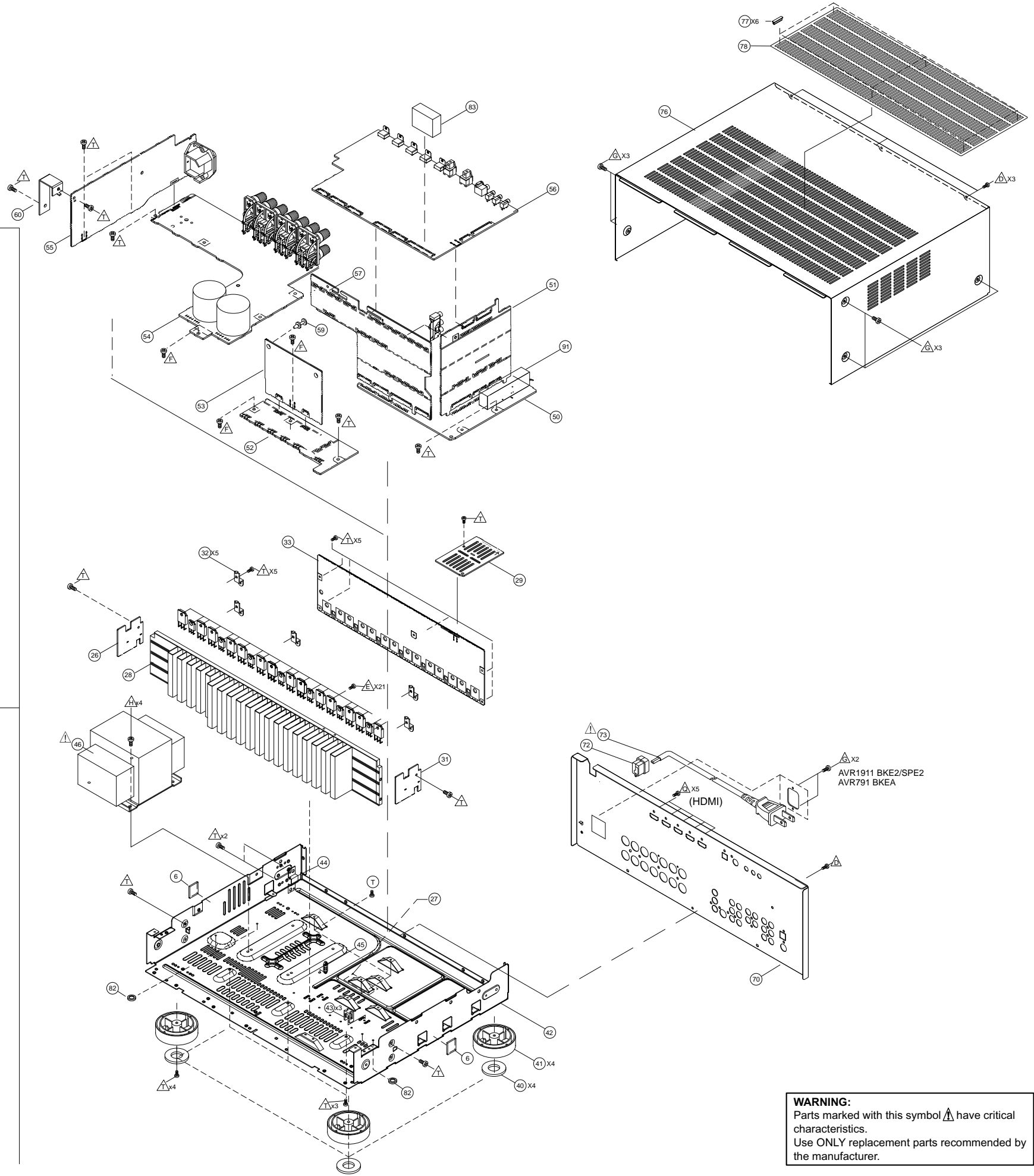

WARNING:
Parts marked with this symbol  have critical characteristics.
Use **ONLY** replacement parts recommended by the manufacturer.

PARTS LIST OF EXPLODED VIEW

- * Parts for which "nsp" is indicated on this table cannot be supplied.
- * P.W.B. ASS'Y for which "nsp" is indicated on this table cannot be supplied. When repairing the P.W.B. ASS'Y, check the board parts table and order replacement parts.
- * Part indicated with the mark "★" is not illustrated in the exploded view.
- * The parts listed below are for maintenance only, might differ from the parts used in the unit in appearances or dimensions.

Note: The symbols in the column "Remarks" indicate the following destinations.
 1911E3 : U.S.A. & Canada model 1911E2 : Europe model 1911E1C : China model
 791E3 : U.S.A. & Canada model 791EA : Australia model
 BK : Black model SP : Premium Silver model

Ref. No.	Part No.	Part Name	Remarks		Q'ty	New
22A	nsp	PCB FRONT ASSY	1911BKE3	7025HK0922013	1	*
22A	nsp	PCB FRONT ASSY	791BKEA	7025HK0922023	1	*
22A	nsp	PCB FRONT ASSY	1911SPE1C	7025HK0922043	1	*
22A	nsp	PCB FRONT ASSY	1911SPE2	7025HK0922053	1	*
22A	nsp	PCB FRONT ASSY	1911BKE2	7025HK0922063	1	*
22A	nsp	PCB FRONT ASSY	791BKE3	7025HK0922073	1	*
11	-	PCB FUNCTION				
14	-	PCB H/P				
21	-	PCB USB				
22	-	PCB FRONT				
23	-	PDB FUNCTION_CNT				
26	-	PCB GUIDE_L				
29	-	PCB TOP_GUIDE				
31	-	PCB GUIDE_R				
33	nsp	PCB 7CH-AMP ASSY	1911BKE3	7025HK0922010	1	*
33	nsp	PCB 7CH-AMP ASSY	791BKEA	7025HK0922020	1	*
33	nsp	PCB 7CH-AMP ASSY	1911SPE1C	7025HK0922040	1	*
33	nsp	PCB 7CH-AMP ASSY	1911SPE2	7025HK0922050	1	*
33	nsp	PCB 7CH-AMP ASSY	1911BKE2	7025HK0922060	1	*
33	nsp	PCB 7CH-AMP ASSY	791BKE3	7025HK0922070	1	*
50	nsp	PCB AUDIO_VIDEO ASSY	1911BKE3	7025HK0922014	1	*
50	nsp	PCB AUDIO_VIDEO ASSY	791BKEA	7025HK0922024	1	*
50	nsp	PCB AUDIO_VIDEO ASSY	1911SPE1C	7025HK0922044	1	*
50	nsp	PCB AUDIO_VIDEO ASSY	1911SPE2	7025HK0922054	1	*
50	nsp	PCB AUDIO_VIDEO ASSY	1911BKE2	7025HK0922064	1	*
50	nsp	PCB AUDIO_VIDEO ASSY	791BKE3	7025HK0922074	1	*
53A	nsp	PCB REG_CNT ASSY	1911BKE3	7025HK0922012	1	*
53A	nsp	PCB REG_CNT ASSY	791BKEA	7025HK0922022	1	*
53A	nsp	PCB REG_CNT ASSY	1911BKE1C	7025HK0922042	1	*
53A	nsp	PCB REG_CNT ASSY	1911BKE2	7025HK0922052	1	*
53A	nsp	PCB REG_CNT ASSY	1911BKE2	7025HK0922062	1	*
53A	nsp	PCB REG_CNT ASSY	791BKE3	7025HK0922072	1	*
51	-	PCB SIDE_CNT				
52	-	PCB REG				
53	-	PCB REG_CNT				
57	-	PCB FRONT_CNT				
54A	nsp	PCB SPK ASSY	1911BKE3	7025HK0922011	1	*
54A	nsp	PCB SPK ASSY	791BKEA	7025HK0922021	1	*
54A	nsp	PCB SPK ASSY	1911SPE1C	7025HK0922041	1	*
54A	nsp	PCB SPK ASSY	1911SPE2	7025HK0922051	1	*
54A	nsp	PCB SPK ASSY	1911BKE2	7025HK0922061	1	*

Ref. No.	Part No.	Part Name	Remarks		Q'ty	New																									
54A	nsp	PCB SPK ASSY	791BKE3	7025HK0922071	1	*																									
54	-	PCB SPK																													
55	-	PCB SMPS																													
56	8U6331005700S	PCB HDMI ASSY	1911BKE3	7025HK0922016	1	*																									
56	8U6331005800S	PCB HDMI ASSY	791BKE3	7025HK0922076	1	*																									
56	nsp	PCB HDMI ASSY	791BKEA	7025HK0922026	1	*																									
56	nsp	PCB HDMI ASSY	1911SPE1C	7025HK0922046	1	*																									
56	nsp	PCB HDMI ASSY	1911SPE2	7025HK0922056	1	*																									
56	nsp	PCB HDMI ASSY	1911BKE2	7025HK0922066	1	*																									
<p>NOTE : </p> <p>Please change the destination-resistors when changing 791BKE3 (8U6331005800S) to other destination. Please refer to destination-resistors 85,86,87 page. (SCHEMATIC DIAGRAMS : 19/23,20/23, 21/23)</p> <table border="1"> <thead> <tr> <th></th> <th>R2704(19/23)</th> <th>R2906(20/23)</th> <th>R3122(21/23)</th> <th>R3119(21/23)</th> </tr> </thead> <tbody> <tr> <td>791BKE3</td> <td>10K</td> <td>OPEN</td> <td>18K</td> <td>3.3K</td> </tr> <tr> <td>791BKEA</td> <td>4.7K</td> <td>OPEN</td> <td>3.3K</td> <td>18K</td> </tr> <tr> <td>1911BKE2</td> <td>4.7K</td> <td>33</td> <td>10K</td> <td>OPEN</td> </tr> <tr> <td>1911SPE1C</td> <td>4.7K</td> <td>OPEN</td> <td>10K</td> <td>10K</td> </tr> </tbody> </table>								R2704(19/23)	R2906(20/23)	R3122(21/23)	R3119(21/23)	791BKE3	10K	OPEN	18K	3.3K	791BKEA	4.7K	OPEN	3.3K	18K	1911BKE2	4.7K	33	10K	OPEN	1911SPE1C	4.7K	OPEN	10K	10K
	R2704(19/23)	R2906(20/23)	R3122(21/23)	R3119(21/23)																											
791BKE3	10K	OPEN	18K	3.3K																											
791BKEA	4.7K	OPEN	3.3K	18K																											
1911BKE2	4.7K	33	10K	OPEN																											
1911SPE1C	4.7K	OPEN	10K	10K																											
1	963416010070D	WINDOW DISPLAY	1911BKE3,791BKE3	5077212762060S	1	*																									
1	963416011350D	WINDOW DISPLAY	1911SPE2,1911BKE2,1911SPE1C,791BKEA	5077212762080S	1	*																									
2	963412000570D	KNOB FUNCTION(KD)	BK	5080211761000SZ	1																										
2	412510003031D	KNOB FUNCTION	SP	5087211901000S	1																										
3	00D9630362109	BADGE DENON	BK	5630210028300S	1																										
3	00D9630362202	BADGE DENON	SP	5630210028400S	1																										
4	963402009830D	PANEL FRONT	1911BKE3	3067214911300S	1	*																									
4	963402009860D	PANEL FRONT	1911BKE2	3067214911400S	1	*																									
4	963402009870D	PANEL FRONT	1911SPE2	3067214911500S	1	*																									
4	963402009880D	PANEL FRONT	1911SPE1C	3067214911510S	1	*																									
4	963402009840D	PANEL FRONT	791BKE3	3067214921210S	1	*																									
4	963402009850D	PANEL FRONT	791BKEA	3067214921310S	1	*																									
5	00D9630137807	LENS STANDBY		3710210503000S	1																										
6	nsp	CUSHION SIDE		4050213095000S	2	*																									
7	963411002820S	BUTTON-ASSY STANDBY(KD)	BK	5098212361000SZ	1																										
7	00D9630221904	BUTTON-ASSY STANDBY	SP	5097212368030SZ	1																										
8	00D9630362305	BUTTON 2KEY	1911BKE3,1911BKE2	5097213351000S	1																										
8	00D9630362501	BUTTON 2KEY	1911SPE2,1911SPE1C	5097213351110S	1																										
8	963411001390D	BUTTON 2KEY	791BKE3,791BKEA	5097213591000S	1																										
12	963419010060D	COVER RCA	BK	4317215141000S	1	*																									
12	963419011380D	COVER RCA	SP	4317215141100S	1	*																									
15	963412000560D	KNOB VOLUME(KD)	BK	5080211751000SZ	1																										
15	412510002038D	KNOB VOLUME	SP	5087211891000S	1																										
16	963411003370D	BUTTON 1KEY	1911BKE3,1911BKE2	5097213791000S	1																										
16	963412003670D	BUTTON 1KEY	1911SPE2,1911SPE1C	5097213791100S	1																										
16-1	963411003770D	BUTTON 1KEY	791BKE3,791BKEA	5097213801000S	1																										
17	963411003380D	BUTTON CURSOR 5KEY	BK	5097213811000S	1																										
17	963411003680D	BUTTON CURSOR 5KEY	SP	5097213811100S	1																										
18	00D9630364700	BUTTON 3KEY	1911BKE3,1911BKE2	5097213331000S	1																										
18	00D9630364906	BUTTON 3KEY	1911SPE2,1911SPE1C	5097213331110S	1																										
18-1	963411001410D	BUTTON 3KEY B	BK	5097213611000S	1																										
18-1	963411011340D	BUTTON 3KEY B	SP	5097213611100S	1	*																									
18-2	963411001400D	BUTTON 3KEY A	791BKE3,791BKEA	5097213601000S	1																										

Ref. No.	Part No.	Part Name	Remarks		Q'ty	New
19	00D9630365002	BUTTON WIN 3KEY	BK	5097213371000S	2	
19	00D9630365301	BUTTON WIN 3KEY	SP	5097213371110S	2	
20	963411003400D	BUTTON WIN 3KEY C	BK	5097213831000S	1	
20	963411003690D	BUTTON WIN 3KEY C	SP	5097213831100S	1	
★ 27	nsp	SHEET RATING CHASSIS		1210211269000S	1	*
28	nsp	HEAT SINK MAIN		2120211788000S	1	*
32	nsp	BRACKET H SINK		4010056906010S	5	
40	nsp	CUSHION FOOT		4050211295000S	4	
41	963407003330D	FOOT		4000210261000S	4	
42	nsp	CHASSIS MAIN		3200213506000S	1	*
43	nsp	SUPPORTER PCB		4070001601010S	3	
44	nsp	BRACKET SIDE		4010210686000S	1	
45	nsp	SUPPORTER P.C.		4070210192000S	1	
⚠ 46	963101009790S	POWER TRANS MAIN	1911BKE3,791BKE3	8200960610730S	1	* ⚠
⚠ 46	963101009800S	POWER TRANS MAIN	1911SPE2,1911BKE2,791BKEA	8200960610740S	1	*
⚠ 46	963101009810S	POWER TRANS MAIN	1911SPE1C	8200960610750S	1	*
59	nsp	SPACER CARD		4300210062000S	1	
60	nsp	BRACKET SMPS		4010214886000S	1	*
61	nsp	PLATE EARTH USB		4470211946000S	1	*
★ 63	00D9960018706	TR 2SB1560-Y	Q410,Q422,Q434,Q446,Q458,Q470,Q482	J5011560Y0000S	7	
★ 64	963219003340S	TR 2SC KTC3964	Q409,Q421,Q433,Q445,Q457,Q469,Q481	J502396400010S	7	
★ 65	00D9960018706	TR 2SD2390-Y	Q404,Q416,Q428,Q440,Q452,Q464,Q476	J5032390Y0000S	7	
70	nsp	CHASSIS BACK	1911BKE3	3207213526500S	1	*
70	nsp	CHASSIS BACK	1911SPE2,1911BKE2	3207213526600S	1	*
70	nsp	CHASSIS BACK	791BKEA	3207213526610S	1	*
70	nsp	CHASSIS BACK	1911SPE1C	3207213526700S	1	*
70	nsp	CHASSIS BACK	791BKE3	3207213526800S	1	*
72	nsp	STOPPER CORD AC	1911BKE3,1911SPE1C,791BKE3	4380210002000S	1	
⚠ 73	00D963029220S	CORD ASSY	1911BKE3,791BKE3	L068125100020S	1	
⚠ 73	00D963034990S	CORD ASSY	1911SPE1C	L068250060010S	1	
76	963401010050D	CABINET TOP	BK	3000211736000S	1	*
76	963403011330D	CABINET TOP	SP	3000211736100S	1	*
77	963454001800D	COVER HOLDER	1911BKE2,791BKEA	4310213701000S	6	
77	963454001810D	COVER HOLDER	1911SPE2,1911SPE1C	4310213701100S	6	
78	963419011370D	COVER SAFETY	1911BKE2,791BKEA	4310215202100S	1	*
78	963419011360D	COVER SAFETY	1911SPE2,1911SPE1C	4310215202000S	1	*
82	nsp	CUSHION SCREW		4050213025000S	4	*
83	nsp	CUSHION		4050213155000S	1	*
★ 88	963606010490S	CABLE,FLAT CARD 1.0MM		N711402912480S	1	*
★ 89	963606011210S	CABLE,FLAT CARD 1.25MM	1911BKE3	N712130824480S	1	
★ 90	nsp	CLAMP CABLE	1911BKE3,1911SPE2,1911BKE2, 1911SPE1C,791BKEA	4330040343010S	9	
★ 90	nsp	CLAMP CABLE	791BKE3	4330040343010S	6	
91	963183011000S	HD-RADIO MODULE	1911BKE3	E908071010000S	1	*
SCREWS						
A	nsp	SCREW +2S 3*8 B-TYPE ZNW/BH		B020030081B10S	23	
C	nsp	SCREW +2S 3*15 B-TYPE ZNW/BH		B020030151B10S	1	
D	nsp	SCREW +2S 3*10 B-TYPE(DOT) BK/BH	1911BKE3,791BKE3,1911SPE1C	B020030103B11S	26	
D	nsp	SCREW +2S 3*10 B-TYPE(DOT) BK/BH	1911SPE2,1911BKE2,791BKEA	B020030103B11S	25	
E	nsp	SCREW +2S 3*14 P(Φ6)+S-WASHER ZNY/HH		B018230141H11S	21	
F	nsp	SCREW +2S 3*17 B-TYPE ZNW/BH		B020030171B10S	3	

Ref. No.	Part No.	Part Name	Remarks		Q'ty	New
G	00D9630048307	SCREW +2S 4*8 B-TYPE(DOT) BK/BH	1911SPE2,1911BKE2,791BKEA : for INLET	1500040083B10S	2	
G	00D9630048307	SCREW +2S 4*8 B-TYPE(DOT) BK/BH	BK : for CABINET TOP	1500040083B10S	6	
G	00D9639004012	SCREW +2S 4*8 B-TYPE(DOT) NI/BH	SP : for CABINET TOP	1500040084B10S	6	
H	nsp	SCREW +3S 4*10 P+S-WASHER(ROUND) BK/BH		B028940101B11S	4	
I	nsp	SCREW +2S 3*8 ZnY WASHER P112		1500001456010S	1	
P	nsp	SCREW +2S 3*8 P19.5 B-TYPE ZNW		1500001206010S	2	
Q	nsp	SCREW +M 3*6 BK/BH		B000030063B10S	5	*
T	nsp	SCREW +2S 3*8(ROUND) BK/BH		B020230083B10S	48	

PACKING VIEW

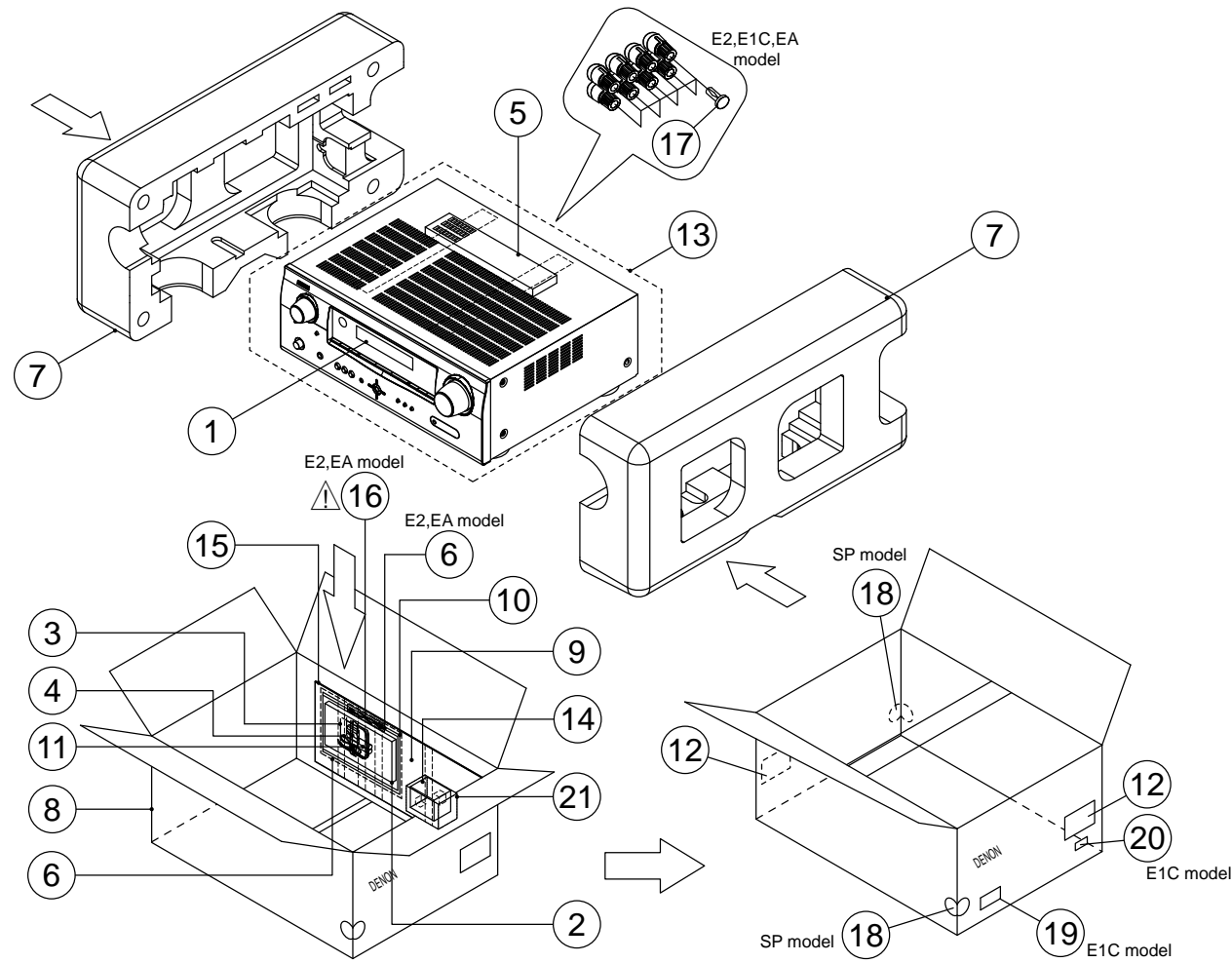

Ref. No.	Part No.	Part Name	Remarks		Q'ty	New	
8	963531010080D	BOX GIFT	791BKE3	6007211690100S	1	*	
8	963531011390D	BOX GIFT	791BKEA	6007211730180S	1	*	
8	963531011400D	BOX GIFT	1911BKE3	6007211730190S	1	*	
8	963531011410D	BOX GIFT	1911SPE2,1911BKE2	6007211730200S	1	*	
8	963531011420D	BOX GIFT	1911SPE1C	6007211730210S	1	*	
9	nsp	WARRANTY CARD	1911BKE3,791BKE3	5727000003002S	1		
9	nsp	WARRANTY CARD	1911SPE1C	5777001670010S	1		
10	nsp	CARD S.S LIST		577700162001GS	1		
11	nsp	BATTERY DRY (AA)		G670001R50190S	2		
12	nsp	LABEL DENON CONTROL		5507000007000S	1	*	
13	nsp	PE SHEET SET		6327040059000S	1		
14	324010001003D	MIC CONDENSER		M040000310040S	1		
15	nsp	PAD BOX BACK		6240210730000S	1		
	16	963611001490S	CORD ASSY	791BKEA	L068250100070S	1	
	16	90M-ZC000600R	CORD ASSY	1911SPE2,1911BKE2	L068250160020S	1	
17	nsp	BUSHING TERMINAL	1911SPE2,1911BKE2,1911SPE1C,791BKEA	2410040353010S	1		
18	nsp	COLOR LABEL	1911SPE2,1911SPE1C	5507020170680S	2		
19	nsp	LABEL PRODUCTION-BOX	1911SPE1C	5507100500970S	1		
20	nsp	LABEL CRoHS	1911SPE1C	5507000000850S	1		
21	nsp	POLY BAG ACCESSORY		6330210222000S	1		
★ 23	nsp	LABEL HOT-SURFACE	1911BKE3	5507000003730S	1		

PARTS LIST OF PACKING & ACCESSORIES

* Parts for which "nsp" is indicated on this table cannot be supplied.

* Part indicated with the mark "★" is not illustrated in the exploded view.

* The parts listed below are for maintenance only, might differ from the parts used in the unit in appearances or dimensions.

Note: The symbols in the column "Remarks" indicate the following destinations.

1911E3 : U.S.A. & Canada model

1911E2 : Europe model

1911E1C : China model

791E3 : U.S.A. & Canada model

791EA : Australia model

BK : Black model

SP : Premium Silver model

Ref. No.	Part No.	Part Name	Remarks		Q'ty	New
1	-	set		-	-	
2	541110418009D	INSTRUCTION MANUAL	791BKE3	5707000003780S	1	*
2	541110420002D	INSTRUCTION MANUAL	791BKEA	5707000003790S	1	*
2	541110417006D	INSTRUCTION MANUAL	1911BKE3	5707000003800S	1	*
2	541110419002D	INSTRUCTION MANUAL	1911SPE2,1911BKE2	5707000003810S	1	*
2	541110421005D	INSTRUCTION MANUAL	1911SPE1C	5707000003830S	1	*
3	90M-ZA000260R	ANTENNA LOOP AM	1911SPE2, 1911BKE2,1911SPE1C,791BKE3,791BKEA	E601016000010S	1	
3	963116011270S	ANTENNA LOOP AM	1911E3 : for HD Radio	E601016400010S	1	
4	00D9600187308	ANTENNA WIRE FM		E605010070001S	1	
5	307010069004D	REMOCON RC-1146		8300114600010S	1	*
6	nsp	POLY BAG	1911BKE3,1911SPE1C,791BKE3	6330000240000S	1	
6	nsp	POLY BAG	1911SPE2,1911BKE2,791BKEA	6330000240000S	2	
7	963533010090D	CUSHION SNOW L/R		6230212814000S	1	*

SEMICONDUCTORS

Only major semiconductors are shown, general semiconductors etc. are omitted to list.
The semiconductor which described a detailed drawing in a schematic diagram are omitted to list.

1. IC's

R5F64169DFD (HDMI :U3102)

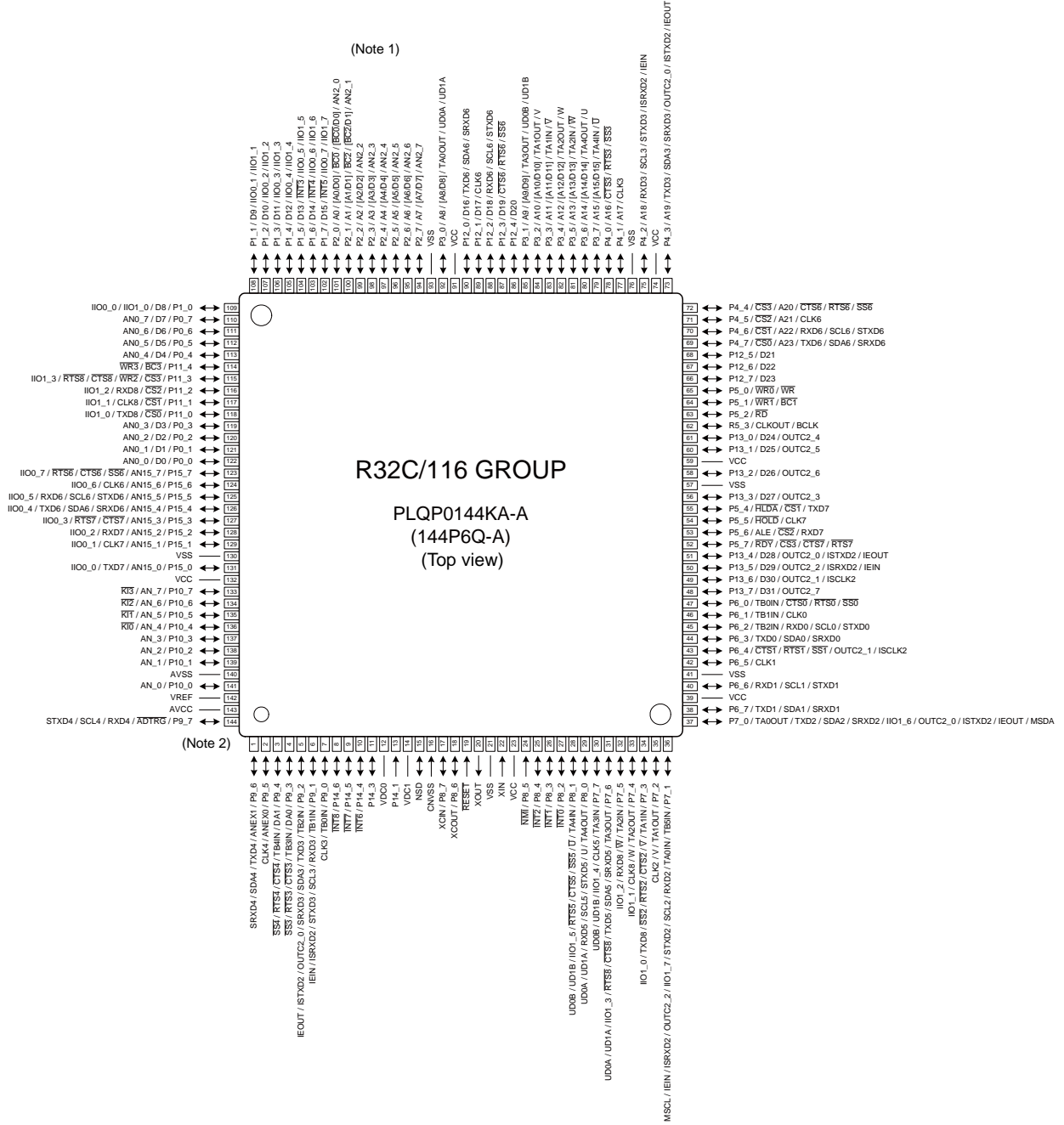

R5F64169DFD Terminal Functions

Pin	Pin Name	Symbol	I/O	Type	Pullup	Lv Cnv	STBY	Stop	Function
1	P96/(TXD4)	NC	O	C	-	3/5	O/L	O/L	NC
2	P95/(CLK4)	HDRADIO RST/TU RST/ST IND	O	C	-	-	O/L	O/L	HDRADIO/TUNER KST-MW/KST-MT control
3	P94/(CTS4)/TB4IN	NC	O/(I)	C	/M3.3	-	I	I	NC
4	P93/(CTS3)/TB3IN	NC	O/(I)	C	/Pd	-	I	I	NC
5	P92/TXD3/SDA3	HDRADIO MOHI/TU SDIO/TU SDA	O	C	-	-	O/L	O/L	HDRADIO/TUNER KST-MW/KST-MT control
6	P91/RXD3/SCL3	HDRADIO MIHO/TU SCLK/TU SCL	I/(O)	-/C	-	-	O/L	O/L	HDRADIO/TUNER KST-MW/KST-MT control
7	P90/(CLK3)	USB POWER(19)/NC(16)	O	C	-	-	O/L	O/L	USB(TELECHIPS) POWER control pin/NC(16)
8	P146/(INT8)	POWER KEY	I	-	M3VPu	-	I	I	POWER KEY (WAIT MODE cancel, interrupt port)
9	P145/(INT7)	REQ SOMI	I	-	-	-	I	O/L	MAIN-SUB u-com communication control output pin
10	P144/(INT6)	MAIN POWER	O	C	-	-	O/L	O/L	MAIN POWER control pin
11	P143	CPU POWER	O	C	-	-	O/L	O/L	MAIN CPU POWER pin (POWER ON: H) CEC ON = STANDBY: H)
12	VDC0	VDC0	-	-	-	-	-	-	Smoothing capacitor connection pin
13	P141 * INPUT ONLY	NC	I	-	Pd	-	-	-	NC
14	VDC1	VDC1	-	-	-	-	-	-	Smoothing capacitor connection pin
15	NSD	NSD	-	-	M3VPu	-	-	-	Emulator communication pin
16	CNVss	CNVSS	-	-	Pd	-	-	-	Single-chip / Micro-processor mode switching (Normal single-chip : L, Rewrite boot program start : H input set)
17	P87/(XCIN)	USB RESET(19)/NC(16)	O	C	-	-	O/L	O/L	USB(TELECHIPS) POWER control pin/NC(16)
18	P86/(XCOUT)	REMOTE POWER(232C)	O	C	-	-	O/L	O/L	232C POWER control pin(ON: H)/
19	RESET	RESET	-	-	M3VPu	-	-	-	Reset input (reset: L)
20	XOUT	X2	-	-	-	-	-	-	Clock output
21	VSS	VSS	-	-	-	-	-	-	GND
22	XIN	X1	-	-	-	-	-	-	Clock input
23	VCC	VCC1	-	-	-	-	-	-	+3V
24	P85/(NMI)	NC	I	-	Pd	-	I	I	NC
25	P84/(INT2)	PLDAERR	I	-	-	-	O/L	O/L	PLD ERROR detection
26	P83/(INT1)	B.DOWN	I	-	M3VPu	-	I	I	Power failure detect(Power failure:L)
27	P82/(INT0)	REMOCON	I	-	Pd	-	I	I	Remote control signal input
28	P81	D5V POWER	O	C	-	-	O/L	O/L	Digital 5V power control pin
29	P80/RXD5	iPod RXD	I/O	-/C	(3Vin)/	5/3	O/L	O/L	IPOD communication control pin
30	P77/(CLK5)	FL DATA	O	C	-	-	O/L	O/L	FL control pin
31	P76/TXD5	iPod TXD	O	C	-	3/5	O/L	O/L	IPOD communication control pin
32	P75/RXD8	NC	I	-	(3Vin)	5/3	O/L	O/L	NC
33	P74/(CLK8)/TA2OUT	NC	O	C	-	-	O/L	O/L	NC
34	P73/TXD8	NC	O/I	C/N	-	3/5	O/L	O/L	VC
35	P72/(CLK2)	OSD CLK	O	C	-	3/5	O/L	O/L	OSD control pin (LC74781)
36	P71/(RXD2)	OSD OE	O	C	-	3/5	O/L	O/L	OSD control pin (LC74781)
37	P70/(TXD2)	OSD DATA	O	C	-	3/5	O/L	O/L	OSD control pin (LC74781)
38	P67/TXD1	TXD MO232I	O	C	-	-	O/L	O/L	Data transfer to external pin(AMX)/MITSUBISHI writer rewrite
39	VCC	VCC1	-	-	-	-	-	-	+3V
40	P66/RXD1	RXD MI232O	I	-	-	-	I	O/L	Data received from the external pin(AMX)/MITSUBISHI writer rewrite
41	VSS	VSS	-	-	-	-	-	-	GND
42	P65/(CLK1)/SCLK(L)	FL CLK	O	C	Pd	-	O/L	O/L	FL control order pin
43	P64/(BUSY)	FL CE1	O	C	-	-	O/L	O/L	FL control order pin
44	P63/TXD0	USB RXDMO(19)/NC(16)	O	C	-	-	O/L	O/L	USB(TELECHIPS) control pin/NC(16)
45	P62/RXD0	USB TXDMI(19)/NC(16)	I	-	-	-	I	O/L	USB(TELECHIPS) control pin/NC(16)
46	P61/(CLK0)	FL RST	O	C	-	-	O/L	O/L	FL control order pin
47	P60/(CTS0)/TB0IN	NC	I	-	Pd	-	-	-	NC
48	P137	ACK SIMO	O	C	-	-	O/L	O/L	MAIN-SUB μcom communication control output pin
49	P136/ISCLK2	CLK SIMO	O	C	-	-	O/L	O/L	MAIN-SUB μcom communication control output pin
50	P135/ISRXD2	SOMI	I	-	-	-	I	O/L	MAIN-SUB μcom communication control output pin
51	P134/ISTXD2	MOSI	O	C	-	-	O/L	O/L	MAIN-SUB μcom communication control output pin
52	P57/(RDY)	NC	I	-	Pd	-	-	-	NC
53	P56/(ALE)	NC	I	-	Pd	-	-	-	NC
54	P55/(HOLD)/EPM	FRASH EPM	I	-	M3VPu	-	-	-	Rewrite boot program start : L input set
55	P54/(HLDA)	NC	I	-	Pd	-	-	-	NC
56	P133	NC	I	-	Pd	-	-	-	NC
57	VSS	VSS	-	-	-	-	-	-	GND
58	P132	NC	I	-	Pd	-	-	-	NC
59	VCC	VCC2	-	-	-	-	-	-	+3V
60	P131	RST SUB	O	C	-	-	O/L	O/L	Output for reset of sub-μcom

Pin	Pin Name	Symbol	I/O	Type	Pullup	Lv Cnv	STBY	Stop	Function
61	P130	SCPU POWER	O	C	-	-	O/L	O/L	SUB CPU POWER ON/OFF switch(H:ON)
62	P53/(BCLK)	NC	I	-	Pd	-	-	-	NC
63	P52/(RD)	NC	I	-	Pd	-	-	-	NC
64	P51/(WR1)/(BC1)	NC	I	-	Pd	-	-	-	NC
65	P50/(WR0)/(WR)/CE	CE	I	-	Pd	-	-	-	Rewrite boot program start : H input set
66	P127	VSEL A	I	-	SW3VPu	-	I	I	Master Volume rotation detect input (Rotary encoder)
67	P126	VSEL B	I	-	SW3VPu	-	I	I	Master Volume rotation detect input (Rotary encoder)
68	P125	232C CONTROL(SUB LOG MODE)	O	C	-	-	O/L	O/L	SUB LOG MODE : For 232C route switch control
69	P47/(CS0)/(A23)	NC	I	-	Pd	-	-	-	NC
70	P46/(CS1)/(A22)	NC	I	-	Pd	-	-	-	NC
71	P45/(CS2)/(A21)	NC	I	-	Pd	-	-	-	NC
72	P44/(CS3)/(A20)	NC	I	-	Pd	-	-	-	NC
73	P43/(A19)	NC	O	C	-	3/5	O/L	O/L	NC
74	VCC	VCC	-	-	-	-	-	-	+3V
75	P42/(A18)	NC	I	-	Pd	-	-	-	NC
76	VSS	VSS	-	-	-	-	-	-	GND
77	P41/(A17)	NC	I	-	Pd	-	-	-	NC
78	P40/(A16)	PROTECTION(THERMAL A)	I	-	SW3VPu	-	I	I	PROTECTION detection pin (THERMAL_A)
79	P37/(A15)	PROTECTION(THERMAL B)	I	-	SW3VPu	-	I	I	PROTECTION detection pin (THERMAL_B)
80	P36/(A14)	PROTECTION(DC DET)	I	-	SW3VPu	-	I	I	PROTECTION detection pin (ASO)
81	P35/(A13)	PROTECTION (ASO)	I	-	SW3VPu	-	I	I	PROTECTION detection pin (DC)
82	P34/(A12)	T.MUTE	O	C	-	-	O/L	O/L	ANALOG TUNER MUTE/HDRADIO MUTE control(MUTE:L)
83	P33/(A11)	NC	I	-	-	-	O/L	O/L	NC
84	P32/(A10)	TU_SEN	O	C	-	-	O/L	O/L	TUNER KST-MW/KST-MT control
85	P31/(A9)	H/P DET	I	-	SW3VPu	-	O/L	O/L	Headphone detection pin
86	P124	NC	I	-	Pd	-	-	-	NC
87	P123	NC	I	-	Pd	-	-	-	NC
88	P122/(RXD6)	EEPROM SCL	I/O	C	M3VPu	-	I	I	EEPROM control terminal
89	P121/(CLK6)	EEPROM SDA	I/O	C	M3VPu	-	I	I	EEPROM control terminal
90	P120/(TXD6)	NC	I	-	Pd	-	-	-	NC
91	VCC	VCC	-	-	-	-	-	-	+3V
92	P30/(A8)	MIC DET	I	-	SW3VPu	-	O/L	O/L	MIC detection pin
93	VSS	VSS	-	-	-	-	-	-	GND
94	P27/(A7)	NC	O	C	-	-	O/L	O/L	NC
95	P26/(A6)	NC	O	C	-	-	O/L	O/L	NC
96	P25/(A5)	NC	O	C	-	-	O/L	O/L	NC
97	P24/(A4)	GRN LED	O	C	-	-	O/L	O/L	POWER LED control pin(ON:H)
98	P23/(A3)	NC	O	C	-	-	O/L	O/L	NC
99	P22/(A2)	NC	O	C	-	-	O/L	O/L	NC
100	P21/(A1)	NC	I	-	Pd	-	-	-	NC
101	P20/(A0)	NC	I	-	Pd	-	-	-	NC
102	P17/(D15)/INT5	TRIGGER 1	O	C	-	-	O/L	O/L	TRIGGER OUT control pin
103	P16/(D14)/INT4	TU GPO2_INT/TUNED	I	-	-	-	O/L	O/L	TUNER KST-MW/KST-MT control
104	P15/(D13)/INT3	NC	I	-	-	3/5	-	-	NC
105	P14/(D12)	LIMIT DET	I	-	SW3VPu	-	I	I	LIMIT judgment signal detection input
106	P13/(D11)	NC	O	C	-	-	O/L	O/L	NC
107	P12/(D10)	LIMIT	O	C	-	-	O/L	O/L	LIMIT control 7ch ST and EXT.IN="H" or (LIMIT DET=45sec"L"="H")
108	P11/(D9)	SB RL	O	C	-	-	O/L	O/L	RELAY control
109	P10/(D8)	H/P RL	O	C	-	-	O/L	O/L	HEADPHONE RLY control
110	P07/(D7)	NC	O	C	-	-	O/L	O/L	NC
111	P06/(D6)	PRE Z2 MUTE	O	C	Pd	-	O/L	O/L	PRE OUT MUTE control
112	P05/(D5)	PRE SB MUTE	O	C	Pd	-	O/L	O/L	PRE OUT MUTE control
113	P04/(D4)	PRE SW MUTE	O	C	Pd	-	O/L	O/L	PRE OUT MUTE control
114	P114	ISEL A	I	-	SW3VPu	-	I	I	Input Selector rotation detect input (Rotary encoder)
115	P113	ISEL B	I	-	SW3VPu	-	I	I	Input Selector rotation detect input (Rotary encoder)
116	P112/(RXD8)	NC	O	C	-	-	O/L	O/L	NC
117	P111/	VOL CLK	O	C	-	-	O/L	O/L	FUNCTION/VOLUME control (R2A15220)
118	P110/(TXD8)	VOL DATA	O	C	-	-	O/L	O/L	FUNCTION/VOLUME control (R2A15220)
119	P03/(D3)	S RL	O	C	-	-	O/L	O/L	RELAY control
120	P02/(D2)	C RL	O	C	-	-	O/L	O/L	RELAY control
121	P01/(D1)	F RL	O	C	-	-	O/L	O/L	RELAY control
122	P00/(D0)	NC	O	C	-	-	O/L	O/L	NC
123	P157	NC	O	C	-	-	O/L	O/L	NC
124	P156	USB RDY(19)/NC(16)	I	-	NET3VPu	-	O/L	O/L	USB(TELECHIPS) control pin

Pin	Pin Name	Symbol	I/O	Type	Pullup	Lv Cnv	STBY	Stop	Function
125	P155/(RXD6)	SUB UPDATE	O	C	-	-	O/L	O/L	SUB UPDATE mode control (DPMS/DENON WRITTER). Normal:L. SUB rewriting mode:H(SUB reset)
126	P154/(TXD6)	iPod DET	I	-	SW3VPu	-	O/L	O/L	MINI JACK connection detection pin for DOCK connection (Connection:H)
127	P153	USB PDN(19)/NC(16)	O	C	NET3VPu	-	O/L	O/L	USB(TELECHIPS) control pin
128	P152/RXD7	NC	I	-	Pd	-	-	-	NC
129	P151/CLK7	NC	I	-	Pd	-	-	-	NC
130	VSS	VSS	-	-	-	-	-	-	GND
131	P150/TXD7	NC	I	-	Pd	-	-	-	NC
132	VCC	VCC	-	-	-	-	-	-	+3V
133	P107/(AN7)/(K13)	NC	O	C	-	-	O/L	O/L	NC
134	P106/AN6/K12	KEY3	I	-	M3VPu	-	I	I	Button input 3
135	P105/AN5/K11	KEY2	I	-	M3VPu	-	I	I	Button input 2
136	P104/AN4/K10	KEY1	I	-	M3VPu	-	I	I	Button input 1
137	P103/(AN3)	NC	I	-	Pd	-	-	-	NC
138	P102/(AN2)	NC	I	-	Pd	-	-	-	NC
139	P101/AN1	MODEL	I	-	M3VPu/Pd	-	I	I	MODEL switch input
140	AVSS	AVSS	-	-	-	-	-	-	Analog GND
141	P100/AN0	MODE	I	-	M3VPu/Pd	-	I	I	Destination switch input
142	VREF	VREF	-	-	-	-	-	-	Standard power input +3V
143	AVCC	AVCC	-	-	-	-	-	-	Analog power +3V
144	P97/(RXD4)	RED LED	O	C	-	-	O/H	O/L	POWER/STANDBY LED control pin (ON:H)

R5F3650KNFB (HDMI : U3301)

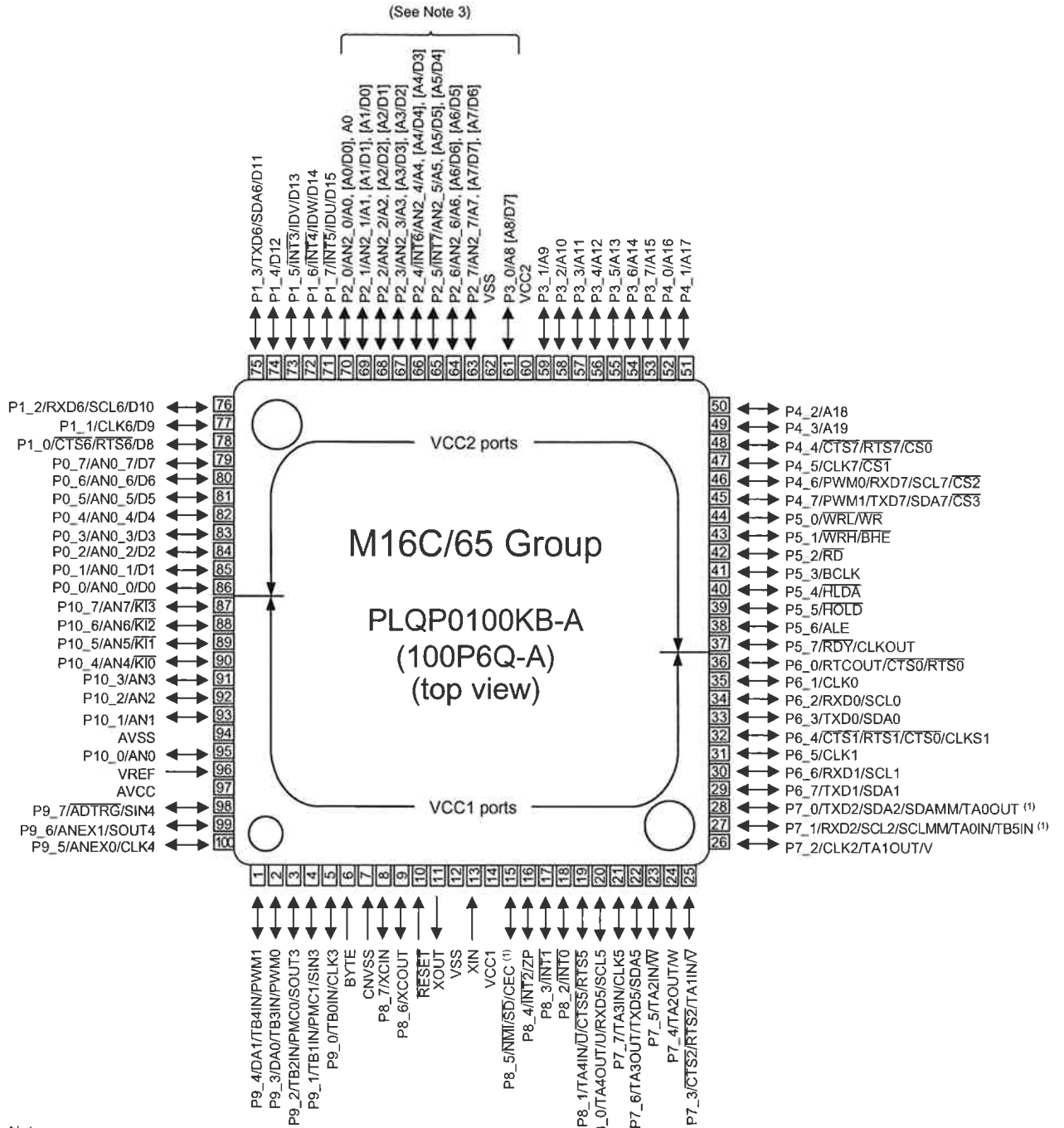

Notes:

1. N-channel open drain output.
2. Check the position of Pin 1 by referring to appendix 1, Package Dimensions.
3. Pin names in brackets [] represent a single functional signal. They should not be considered as two separate functional signals.

R5F3650KNFB Terminal Functions

Pin	Pin Name	Symbol	I/O	Type	Det	Op (Int.)	Pu/Pd (Ext.)	Res	PURE D	CEC STBY	P.OFF	Function
1	P94	NC	I	-	-	-	Pd	Z	-	-	Z	NC
2	P93	DIR CE	O	C	-	-	-	Z	O/L	O/L	Z	DIR control pin (LC89058W-VF4A)
3	P92/SOUT3	DIR DIN	O	C	-	-	-	Z	O/L	O/L	Z	DIR control pin (LC89058W-VF4A)
4	P91/SIN3	DIR DOUT	I	-	Lv	-	DA3.3Pu	Z	-	-	Z	DIR control pin (LC89058W-VF4A)
5	P90/CLK3	DIR CLK	O	C	-	-	-	Z	O/L	O/L	Z	DIR control pin (LC89058W-VF4A)
6	BYTE	BYTE	-	-	-	-	-	-	-	-	-	GND(Ext. data bus bit width switching, 16bit : L)
7	CNVCS	CNVSS	-	-	-	-	Pd	-	-	-	-	Single-chip/Micro-processor mode switching (Normal single-chip : L, Rewrite boot program start : H input set)
8	P87	ADC RST	O	C	-	-	-	Z	O/L	O/L	Z	AD(*****) control pin
9	P86	NC	O	C	-	-	-	Z	O/L	O/L	Z	DIR control pin (LC89058W-VF4A)
10	RESET	SUBRESET	I	-	Lv	-	SCPU3VPu	L	-	-	Z	Reset input
11	XOUT	X1	O	-	-	-	-	-	-	-	-	Oscillator connection
12	VSS	VSS	-	-	-	-	-	-	-	-	-	GND
13	XIN	X2	I	-	-	-	-	-	-	-	-	Oscillator connection
14	VCC	VCC	-	-	-	-	-	-	-	-	-	+3.3V
15	P85(N)/(NMI)/(CEC)	(CEC_IN)	I	-	-	-	Pd	-	-	-	-	NC ("H" fixed/Reserve (16pin CEC-D signal input for TEST))
16	P84/INT2	CEC_IN	I	-	E↓&L	-	SCPU3VPu	Z	-	-	Z	CEC-D signal input pin
17	P83/INT1	ACK SIMO	I	-	E↓&L	-	-	Z	-	-	Z	MAIN-SUB ucom communication control input pin (MAIN ucom Hack:L Return)
18	P82/INT0	SUB BDOWN	I	-	E↓&L	-	-	Z	-	-	Z	Power failure detect(Power failure:L)
19	P81	ABT RST	O	C	-	-	-	Z	O/H	O/H	Z	IP CONV(ABT2015) Reset
20	P80/(RXD5)	NC	I	-	-	-	Pd	Z	-	-	Z	NC
21	P77/(CLK5)	SUB TDO	I	-	-	-	-	Z	O/L	O/L	Z	PLD rewriting control (JTAG)
22	P76/(TXD5)	A PLD CS "/D/M"	O	C	-	-	-	Z	O/L	-	O/L	A PLD control pin/ DENON WRITTER /MITSUBISHI rewritten for determining (DW :L)
23	P75	A PLD DATA	O	C	-	-	-	Z	O/L	O/L	Z	A PLD control pin
24	P74	A PLD CLK	O	C	-	-	-	Z	O/L	O/L	Z	A PLD control pin
25	P73/CTS2	NC	I	-	-	-	Pd	Z	-	-	Z	NC
26	P72/CLK2	DA POWER	O	C	-	-	-	Z	Z	-	Z	DIGITAL power (DA3.3V,DA1.2V) ON/OFF control (H: ON)
27	P71(N)/RXD2/ SCLMM	HSCL(400k)	I/O	N	-	-	CEC3VPu	Z	O/L	O/L	O/L	VIDEO I2C- IP CONV(ABT1030)/HDMI_R(ADV7840) /HDMI T(ADV7511)
28	P70(N)/TXD2/ SDAMM	HSDA(400k)	I/O	N	-	-	CEC3VPu	Z	O/L	O/L	O/L	VIDEO I2C- IP CONV(ABT1030)/HDMI_R(ADV7840) /HDMI T(ADV7511)
29	P67/TXD1	TXD	O	C	-	-	SCPU3VPu	Z	-	-	Z	Data transmission output to external
30	P66/RXD1	RXD	I	-	Lv	-	SCPU3VPu	Z	-	-	Z	Data reception input from the external
31	P65/CLK1/SCLK	SCLK	I	-	-	-	Pd	Z	-	-	Z	Emulator communication pin
32	P64/CTS1	NC	I	-	-	-	Pd	Z	-	-	Z	NC
33	P63/TXD0	SOMI	O	C	-	-	-	Z	-	-	Z	MAIN-SUB ucom communication control pin
34	P62/RXD0	SIMO	I	-	-	-	-	Z	-	-	Z	MAIN-SUB ucom communication control pin
35	P61/CLK0	CLK SIMO	I	-	-	-	-	Z	-	-	Z	MAIN-SUB ucom communication control pin
36	P60/CTS0	REQ SOMI	O	C	-	-	-	Z	-	-	Z	MAIN-SUB ucom communication control pin
37	P57	NC	O	C	-	-	-	Z	-	O/L	O/L	NC
38	P56	DV POWER2	O	C	-	-	-	Z	O/L	-	Z	DIGITAL.VIDEO power control pin (DV1.8V)
39	P55/EPM	EPM	I	-	-	-	Pd	Z	-	-	Z	Rewrite boot program start : L input set
40	P54	CEC_OUT	O	C	-	-	-	Z	O/L	-	Z	CEC-D signal input pin
41	P53	NC	I	-	-	-	Pd	Z	-	-	Z	NC
42	P52	NC	I	-	-	-	Pd	Z	-	-	Z	NC
43	P51	NC	I	-	-	-	Pd	Z	-	-	Z	NC
44	P50/CE	CE/DSP BOOT	O/I	C	-	-	SCPU3VPu	Z	O/L	-	Z	MONI SEL(for Dual Moni)(MAX4886) /Rewrite boot program start : H input set
45	P47/(TXD7)/(SDA7)	COMP SW2	O	C	-	-	-	Z	O/L	O/L	O/L	VIDEO SELECT IC(NJW2586)
46	P46/(RXD7)/(SCL7)	COMP SW1	O	C	-	-	-	Z	O/L	O/L	O/L	VIDEO SELECT IC(NJW2586)
47	P45/(CLK7)	NC	I	-	-	-	Pd	Z	-	-	Z	NC
48	P44	HPD1	O	C	-	-	-	Z	O/L	O/L	Z	HP DET control pin
49	P43	NC	I	-	-	-	Pd	Z	-	-	Z	NC
50	P42	NC	I	-	-	-	Pd	Z	-	-	Z	NC
51	P41	CEC POWER	O	C	-	-	-	Z	O/L	O/H	Z	Power ON (CEC5V,CEC3.3V,CEC1.8V) for CEC STANDBY
52	P40	HPD2	O	C	-	-	-	Z	O/L	O/L	Z	HP DET control pin
53	P37	HDMIR_RST	O	C	-	-	SCPU3VPu	Z	O/H	-	Z	Reset for HDMI RECEIVER(ADV7840)
54	P36	1TX RST	O	C	-	-	SCPU3VPu	Z	O/H	-	Z	Reset for HDMI TRANSMITTER (ADV7511)
55	P35	NC	I	-	-	-	Pd	Z	-	-	Z	NC
56	P34	Z1 SSGDET	I	-	Lv	-	SCPU3VPu	Z	-	-	Z	S signal presence detection input (Connected: H)
57	P33	HPD3	O	C	-	-	-	Z	O/L	O/L	Z	HP DET control pin

Pin	Pin Name	Symbol	I/O	Type	Det	Op (Int.)	Pu/Pd (Ext.)	Res	PURE D	CEC STBY	P.OFF	Function
58	P32	DAC MDI	O	C	-	-	-	Z	O/L	O/L	Z	DAC control pin (ASK4358)
59	P31	DAC MC	O	C	-	-	-	Z	O/L	O/L	Z	DAC control pin (ASK4358)
60	VCC	VCC	-	-	-	-	-	-	-	-	-	+3.3V
61	P30	DAC MS	O	C	-	-	-	Z	O/L	O/L	Z	DAC control pin (ASK4358)
62	VSS	VSS	-	-	-	-	-	-	-	-	-	GND
63	P27	DAC RST	O	C	-	-	-	Z	O/H	O/L	Z	DAC control pin (ASK4358)
64	P26	DV POWER	O	C	-	-	-	Z	O/L	MODE1=O/H MODE2=O/L	Z	"DIGITAL VIDEO power control pin (DV5V,DV3.3V)
65	P25/INT7	NC	I	-	Lv	-	Pd	Z	-	-	Z	NC
66	P24/INT6	1TX INT	I	-	Lv	-	DV3Pu	Z	-	-	Z	HDMI OUT1 signal presence detection input (HDMI TRANS1 ADV7511)
67	P23	SUB TMS	O	C	-	-	DA3.3Pu	Z	O/L	-	Z	PLD rewriting control (JTAG)
68	P22	VEXP STB	O	C	-	-	-	Z	O/L	O/L	Z	NC
69	P21	VEXP OE	O	C	-	-	-	Z	O/L	O/L	Z	NC
70	P20	VEXP CLK	O	C	-	-	-	Z	O/L	O/L	Z	NC
71	P17/INT5	ADVINT1	I	-	E _L &L	-	-	Z	-	-	Z	HDMI RECEIVER(ADV7840) INT1 output
72	P16/INT4	ADVINT2	I	-	E _L &L	-	-	Z	-	-	Z	HDMI RECEIVER(ADV7840) INT2 output
73	P15/INT3	ADVINT3	I	-	E _L &L	-	-	Z	-	-	Z	HDMI RECEIVER(ADV7840) INT3 output
74	P14	HPD4	O	C	-	-	-	Z	O/L	O/L	Z	HP DET control pin
75	P13/TXD6	DSP MOSI	O	C	-	-	DA3VPu	Z	O/L	O/L	Z	DSP control pin (ADSP-21367-333)
76	P12/RXD6	DSP MISO	I	-	Lv	-	DA3VPu	Z	-	-	Z	DSP control pin (ADSP-21367-333)
77	P11/CLK6	DSPICLK	O	C	-	-	DA3VPu	Z	O/L	O/L	Z	DSP control pin (ADSP-21367-333)
78	P10	Z1V5SIG.DET	I	-	Lv	-	SCPU3VPu	Z	-	-	Z	VIDEO IN signal presence detection input signal (input:H)
79	P07	SUB TDI	O	C	-	-	DA3.3Pu	Z	O/L	O/L	Z	PLD rewriting control (JTAG)
80	P06	NC	I	-	-	-	Pd	Z	-	-	Z	NC
81	P05	NC	I	-	-	-	Pd	Z	-	-	Z	NC
82	P04	NC	I	-	-	-	Pd	Z	-	-	Z	NC
83	P03	SUB TCK	O	C	-	-	Pd	Z	O/L	-	Z	PLD rewriting control (JTAG)
84	P02	NC	I	-	-	-	Pd	Z	-	-	Z	NC
85	P01	NC	I	-	-	-	Pd	Z	-	-	Z	NC
86	P00	DIR RST1	O	C	-	-	-	Z	O/L	O/L	O/L	DIR control pin (LC89058W-VF4A)
87	P107/(AN7)	DSP RST	O	C	-	-	-	Z	O/L	O/L	Z	DSP(ADSP-21367-333) reset output pin (Reset : L)
88	P106/(AN6)	NC	I	-	-	-	Pd	Z	-	-	Z	NC
89	P105/(AN5)	DSP ROMRST	O	C	-	-	-	Z	O/L	O/L	Z	Memory reset for DSP (Reset : L)
90	P104/(AN4)	COMPS DET	I	-	Lv	-	SCPU3VPu	Z	-	-	Z	COMPONENT IN signal presence detection input
91	P103/(AN3)	DSP FLAG0	I	-	Lv	-	Pd	Z	-	-	Z	DSP control pin ADSP-21367-333
92	P102/(AN2)	DSP ICS	O	C	-	-	DA3VPu	Z	O/L	O/L	Z	DSP control pin ADSP-21367-333
93	P101/(AN1)	NC	I	-	-	-	Pd	Z	-	-	Z	NC
94	AVSS	AVSS	-	-	-	-	-	-	-	-	-	AD GND
95	P100/(AN0)	NC	I	-	-	-	Pd	Z	-	-	Z	NC
96	VREF	VREF	-	-	-	-	-	-	-	-	-	AD standard +3.3V
97	AVCC	AVCC	-	-	-	-	-	-	-	-	-	AD +3.3V
98	P97/(SIN4)	NC	I	-	-	-	Pd	Z	-	-	Z	NC
99	P96/(SOUT4)	NC	I	-	-	-	Pd	Z	-	-	Z	NC
100	P95/(CLK4)	VEXP DIN	O	C	-	-	-	Z	O/L	O/L	Z	NC

ADV7511BSTZ (HDMI : U1501)

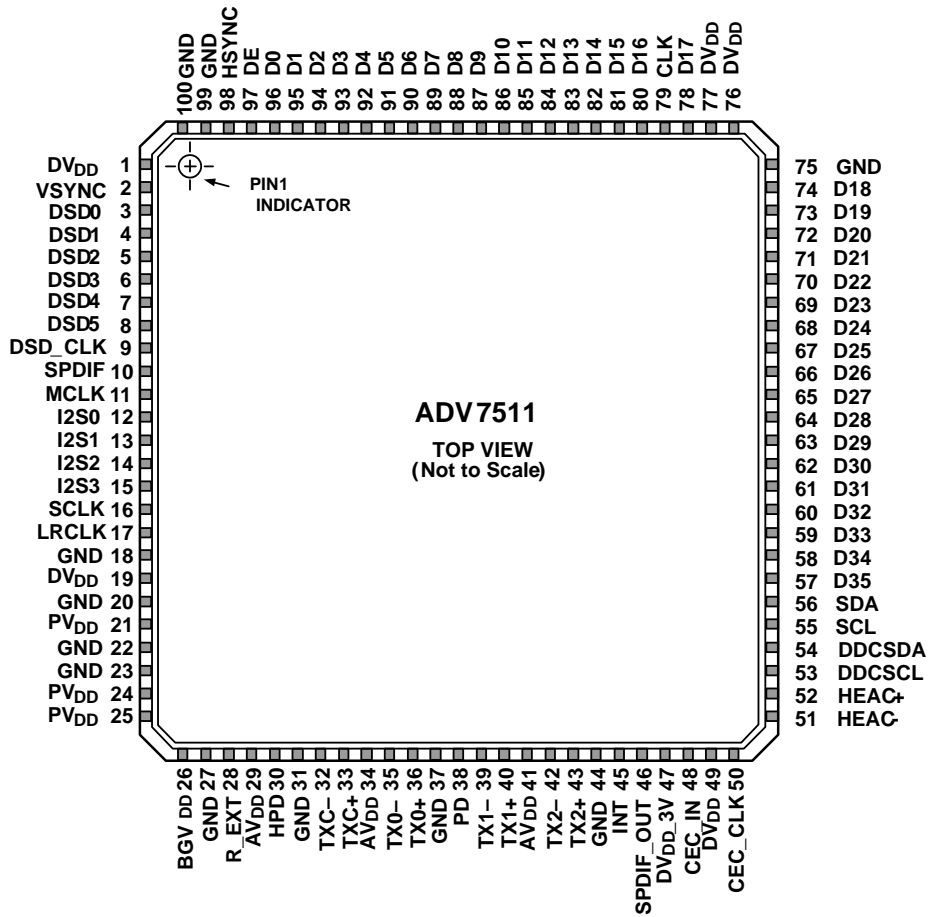

ADV7511BSTZ Block diagram

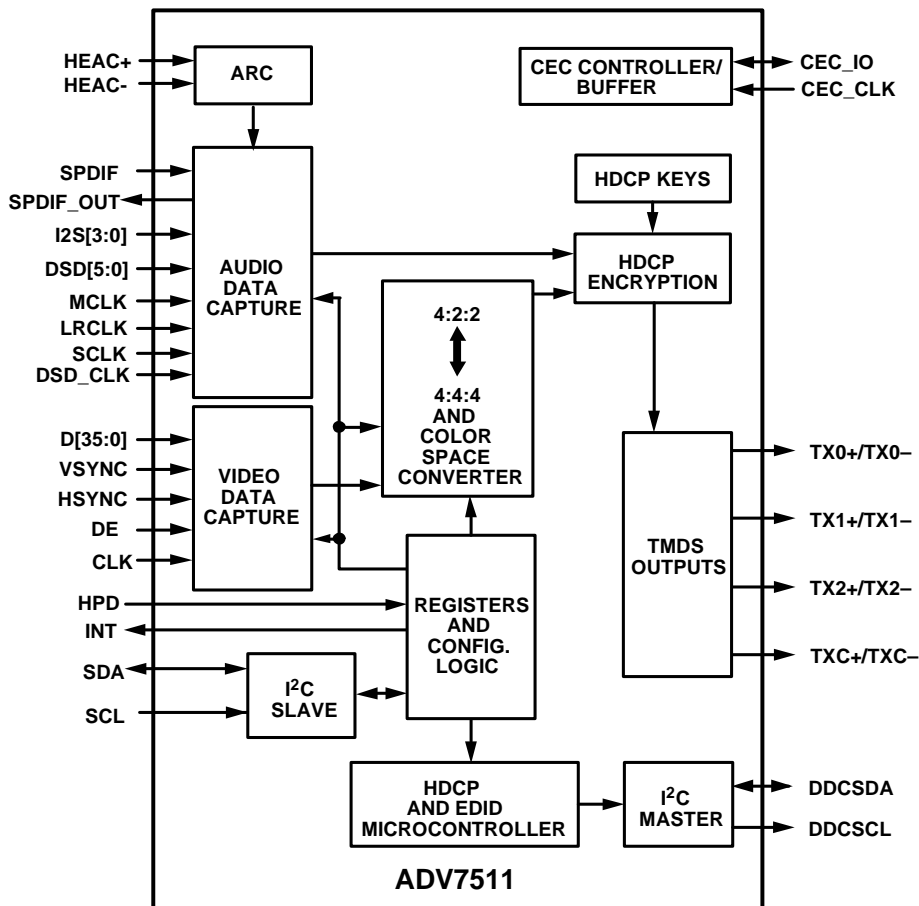

LC89058W-E (HDMI : U1706)

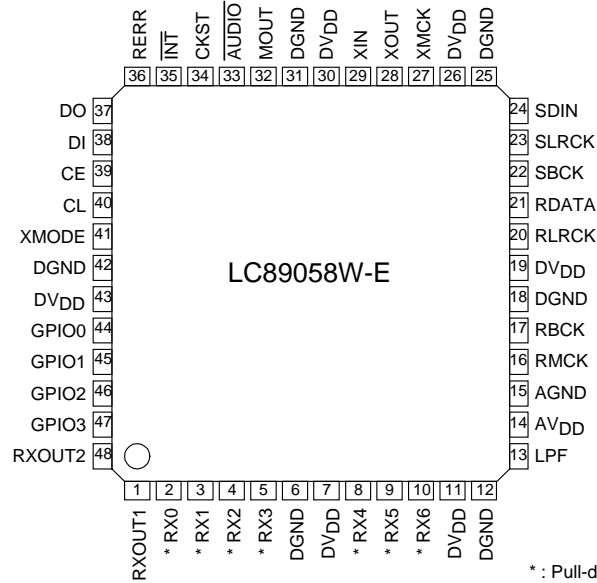

Pin Functions

Pin No.	Name	I/O	Function
1	RXOUT1	O	RX0-6 input S/PDIF through output pin 1
2	RX0	I _s (pd)	5V withstand voltage TTL input level compatible S/PDIF input pin (connected to GND when RX1 is set)
3	RX1	I(pd)	Co-axial compatible S/PDIF input pin (supported demodulation sampling frequency of up to 96kHz)
4	RX2	I _s (pd)	5V withstand voltage TTL input level compatible S/PDIF input pin (connected to GND when RX1 is set)
5	RX3	I _s (pd)	5V withstand voltage TTL input level compatible S/PDIF input pin
6	DGND		Digital GND
7	DV _{DD}		Digital power supply (3.3V)
8	RX4	I _s (pd)	5V tolerable TTL input level compatible S/PDIF input pin
9	RX5	I _s (pd)	5V tolerable TTL input level compatible S/PDIF input pin
10	RX6	I _s (pd)	5V tolerable TTL input level compatible S/PDIF input pin
11	DV _{DD}		Digital power supply (3.3V)
12	DGND		Digital GND
13	LPF	O	PLL loop filter connection pin
14	AV _{DD}		Analog power supply (3.3V)
15	AGND		Analog GND
16	RMCK	O	R system clock output pin (VCO, 512fs, XIN)
17	RBCK	O/I	R system bit clock I/O pin (64fs)
18	DGND		Digital GND
19	DV _{DD}		Digital power supply (3.3V)
20	RLRCK	O/I	R system LR clock I/O pin (fs)
21	RDATA	O	Serial audio data output pin
22	SBCK	O	S system bit clock output pin (16fs, 32fs, 64fs, 128fs)
23	SLRCK	O	S system LR clock output pin (fs/4, fs/2, fs, 2fs)
24	SDIN	I _s	External serial audio data input pin

Pin No.	Name	I/O	Function
25	DGND		Digital GND
26	DV _{DD}		Digital power supply (3.3V)
27	XMCK	O	Oscillation amplifier clock output pin
28	XOUT	O	Output pin connected to the resonator
29	XIN	I	External clock input pin, connected to the resonator (12.288MHz/24.576MHz)
30	DV _{DD}		Digital power supply
31	DGND		Digital GND
32	MOUT	I/O	Emphasis information Input fs monitor output Chip address setting input pin
33	AUDI _O	I/O	Channel status bit 1 output Chip address setting input pin
34	CKST	I/O	Clock switching transition period signal output Master/slave setting input pin
35	INT	I/O	Microcontroller interrupt signal output Pins44-48 I/O setting input pin
36	RERR	O	PLL lock error, data error flag output pin
37	DO	O	CCB microcontroller I/F, read data output pin (3-state)
38	DI	I _S	CCB microcontroller I/F, write data input pin
39	CE	I _S	CCB microcontroller I/F, chip enable input pin
40	CL	I _S	CCB microcontroller I/F, clock input pin
41	XMODE	I _S	System reset input pin
42	DGND		Digital GND
43	DV _{DD}		Digital power supply (3.3V)
44	GPIO0	O/I	General-purpose I/O pin Selector input pin (output referred to RDATA pin)
45	GPIO1	O/I	General-purpose I/O pin Selector input pin (output referred to RLRCK pin)
46	GPIO2	O/I	General-purpose I/O pin Selector input pin (output referred to RBCK pin)
47	GPIO3	O/I	General-purpose I/O pin Selector input pin (output referred to RMCK pin)
48	RXOUT2	O	RX0-6 input S/PDIF through output pin 2

* Input voltage: I= -0.3 to 3.6V, I_S = -0.3 to 5.5V

* Output voltage: O= -0.3 to 3.6V

* Pins 2, 4, 5, 8, 9, 10, 24, 38, 39, 40, and 41 have an internal pull-down resistor (pd).

Their level is fixed when they are unselected.

* Pins 32 and 33 are input pins for chip address setting when pin 41 is held at the low level.

* Pin 34 serves as the input pin for designating as the master or slave when pin 41 is held at the low level.

* Pin 35 serves as the input pin for configuring the I/O of pins 44 to 47 when pin 41 is held at the low level.

* The DV_{DD} and AV_{DD} pins must be held at the same level and turned on and off at the same timing to preclude Latch-up conditions.

LC89058W-E Block diagram

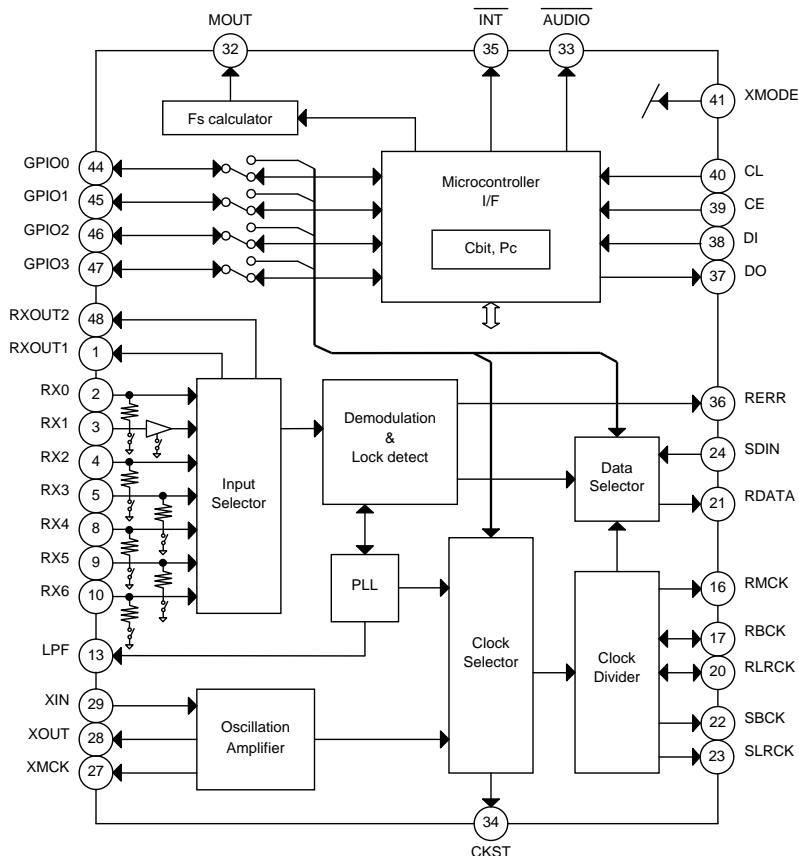

ADSP21367KSWZ2A (HDMI : U1901)

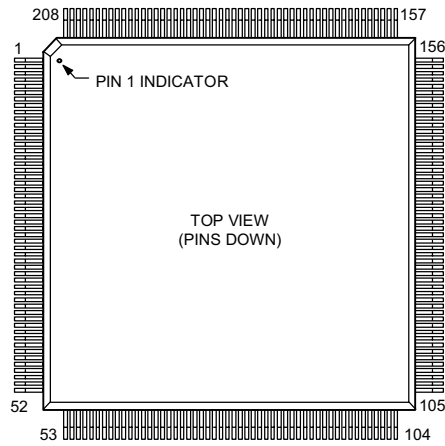

ADSP21367KSWZ2A Terminal Function

Pin No.	Signal	Pin No.	Signal	Pin No.	Signal	Pin No.	Signal
1	VDD	53	VDD	105	VDD	157	VDD
2	DATA28	54	GND	106	GND	158	VDD
3	DATA27	55	IOVDD	107	IOVDD	159	GND
4	GND	56	ADDR0	108	\overline{SDCAS}	160	VDD
5	IOVDD	57	ADDR2	109	\overline{SDRAS}	161	VDD
6	DATA26	58	ADDR1	110	\overline{SDCKE}	162	VDD
7	DATA25	59	ADDR4	111	\overline{SDWE}	163	TDI
8	DATA24	60	ADDR3	112	\overline{WR}	164	\overline{TRST}
9	DATA23	61	ADDR5	113	SDA10	165	TCK
10	GND	62	GND	114	GND	166	GND
11	VDD	63	VDD	115	IOVDD	167	VDD
12	DATA22	64	GND	116	SDCLK0	168	TMS
13	DATA21	65	IOVDD	117	GND	169	CLK_CFG0
14	DATA20	66	ADDR6	118	VDD	170	BOOTCFG0
15	IOVDD	67	ADDR7	119	\overline{RD}	171	CLK_CFG1
16	GND	68	ADDR8	120	ACK	172	\overline{EMU}
17	DATA19	69	ADDR9	121	FLAG3	173	BOOTCFG1
18	DATA18	70	ADDR10	122	FLAG2	174	TDO
19	VDD	71	GND	123	FLAG1	175	DAI4
20	GND	72	VDD	124	FLAG0	176	DAI2
21	DATA17	73	GND	125	DAI20	177	DAI3
22	VDD	74	IOVDD	126	GND	178	DAI1
23	GND	75	ADDR11	127	VDD	179	IOVDD
24	VDD	76	ADDR12	128	GND	180	GND
25	GND	77	ADDR13	129	IOVDD	181	VDD
26	DATA16	78	GND	130	DAI19	182	GND
27	DATA15	79	VDD	131	DAI18	183	DPI14
28	DATA14	80	AVSS	132	DAI17	184	DPI13
29	DATA13	81	AVDD	133	DAI16	185	DPI12
30	DATA12	82	GND	134	DAI15	186	DPI11
31	IOVDD	83	CLKIN	135	DAI14	187	DPI10
32	GND	84	XTAL2	136	DAI13	188	DPI9
33	VDD	85	IOVDD	137	DAI12	189	DPI8
34	GND	86	GND	138	VDD	190	DPI7
35	DATA11	87	VDD	139	IOVDD	191	IOVDD
36	DATA10	88	ADDR14	140	GND	192	GND
37	DATA9	89	GND	141	VDD	193	VDD
38	DATA8	90	IOVDD	142	GND	194	GND
39	DATA7	91	ADDR15	143	DAI11	195	DPI6
40	DATA6	92	ADDR16	144	DAI10	196	DPI5
41	IOVDD	93	ADDR17	145	DAI8	197	DPI4
42	GND	94	ADDR18	146	DAI9	198	DPI3
43	VDD	95	GND	147	DAI6	199	DPI1
44	DATA4	96	IOVDD	148	DAI7	200	DPI2
45	DATA5	97	ADDR19	149	DAI5	201	CLKOUT
46	DATA2	98	ADDR20	150	IOVDD	202	\overline{RESET}
47	DATA3	99	ADDR21	151	GND	203	IOVDD
48	DATA0	100	ADDR23	152	VDD	204	GND
49	DATA1	101	ADDR22	153	GND	205	DATA30
50	IOVDD	102	$\overline{MS1}$	154	VDD	206	DATA31
51	GND	103	$\overline{MS0}$	155	GND	207	DATA29
52	VDD	104	VDD	156	VDD	208	VDD

W9864G2IH-6 (HDMI : U1902)

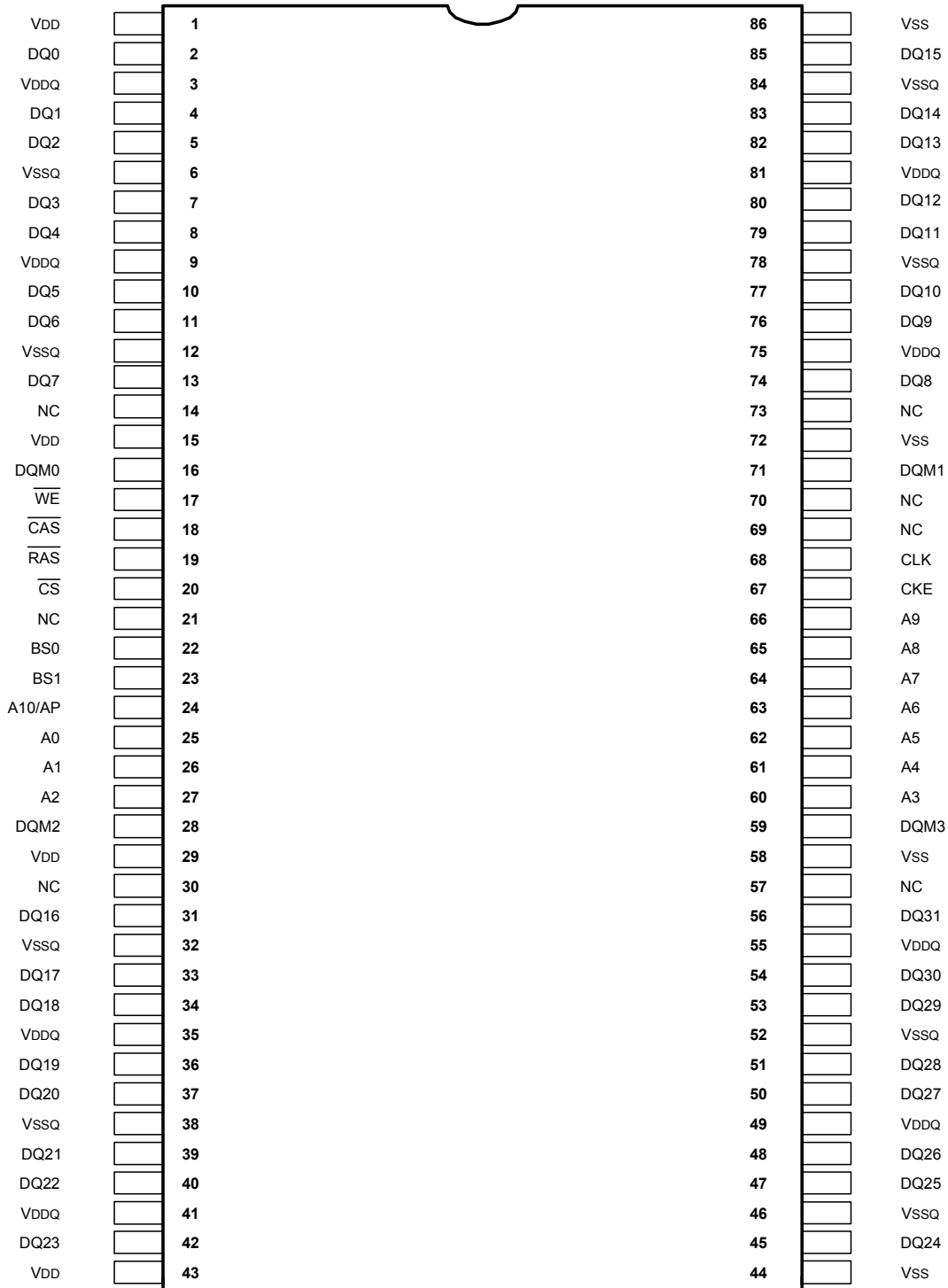

W9864G2IH-6 Block diagram

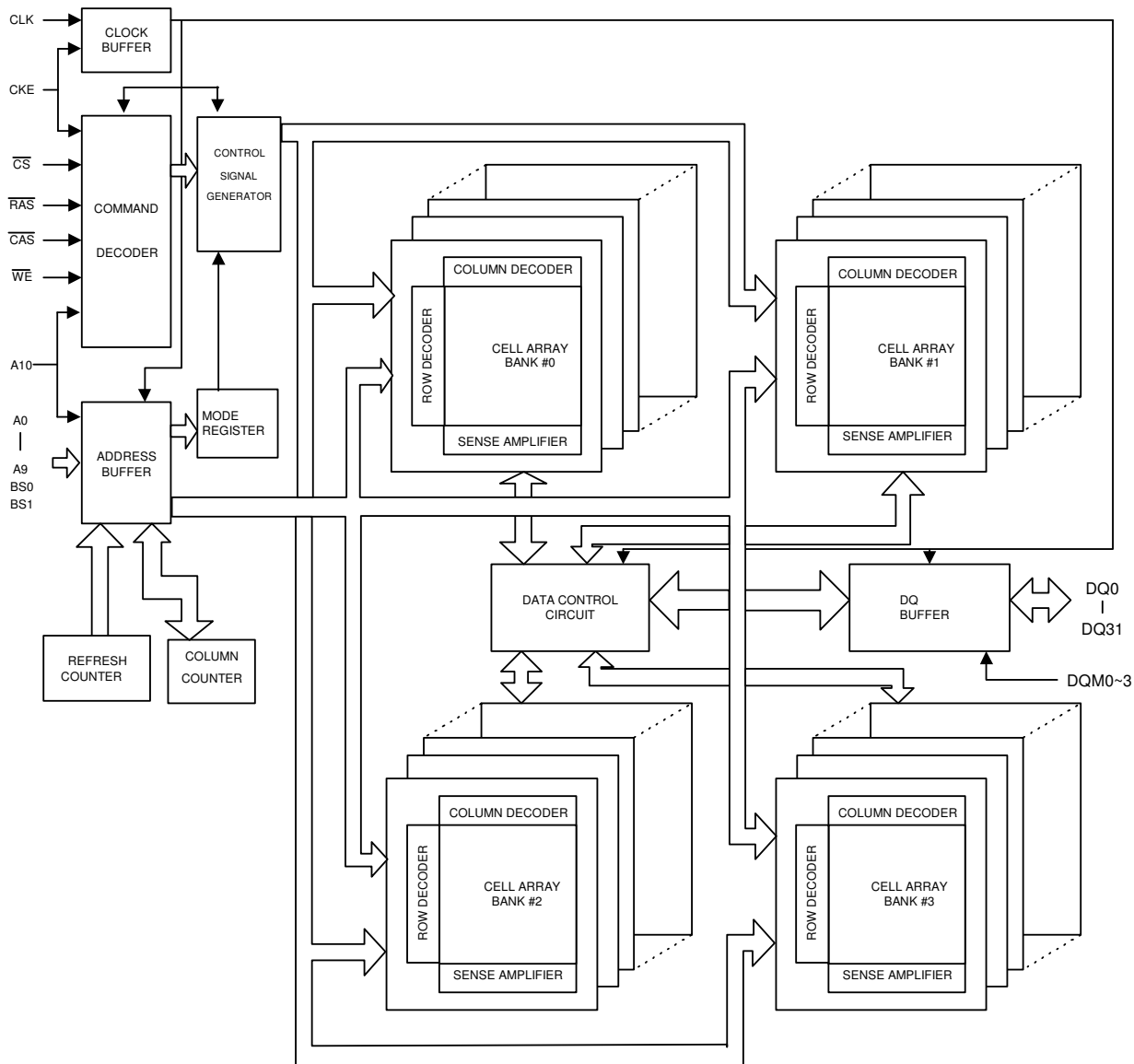

W9864G2IH-6 Pin description

PIN NUMBER	PIN NAME	FUNCTION	DESCRIPTION
24, 25, 26, 27, 60, 61, 62, 63, 64, 65, 66	A0–A10	Address	Multiplexed pins for row and column address. Row address: A0–A10. Column address: A0–A7. A10 is sampled during a precharge command to determine if all banks are to be precharged or bank selected by BS0, BS1.
22, 23	BS0, BS1	Bank Select	Select bank to activate during row address latch time, or bank to read/write during address latch time.
2, 4, 5, 7, 8, 10, 11, 13, 31, 33, 34, 36, 37, 39, 40, 42, 45, 47, 48, 50, 51, 53, 54, 56, 74, 76, 77, 79, 80, 82, 83, 85	DQ0–DQ31	Data Input/ Output	Multiplexed pins for data output and input.
20	\overline{CS}	Chip Select	Disable or enable the command decoder. When command decoder is disabled, new command is ignored and previous operation continues.
19	\overline{RAS}	Row Address Strobe	Command input. When sampled at the rising edge of the clock \overline{RAS} , \overline{CAS} and \overline{WE} define the operation to be executed.
18	\overline{CAS}	Column Address Strobe	Referred to \overline{RAS}
17	\overline{WE}	Write Enable	Referred to \overline{RAS}
16, 28, 59, 71	DQM0–DQM3	Input/Output Mask	The output buffer is placed at Hi-Z (with latency of 2) when DQM is sampled high in read cycle. In write cycle, sampling DQM high will block the write operation with zero latency.
68	CLK	Clock Inputs	System clock used to sample inputs on the rising edge of clock.
67	CKE	Clock Enable	CKE controls the clock activation and deactivation. When CKE is low, Power Down mode, Suspend mode, or Self Refresh mode is entered.
1, 15, 29, 43	VDD	Power	Power for input buffers and logic circuit inside DRAM.
44, 58, 72, 86	VSS	Ground	Ground for input buffers and logic circuit inside DRAM.
3, 9, 35, 41, 49, 55, 75, 81	VDDQ	Power for I/O Buffer	Separated power from VDD, to improve DQ noise immunity.
6, 12, 32, 38, 46, 52, 78, 84	VSSQ	Ground for I/O Buffer	Separated ground from VSS, to improve DQ noise immunity.
14, 21, 30, 57, 69, 70, 73	NC	No Connection	No connection.

EN29LV160BB (HDMI : U1903) : Bottom boot Sector
EN29LV160BT (HDMI : U2301) : Top boot Sector

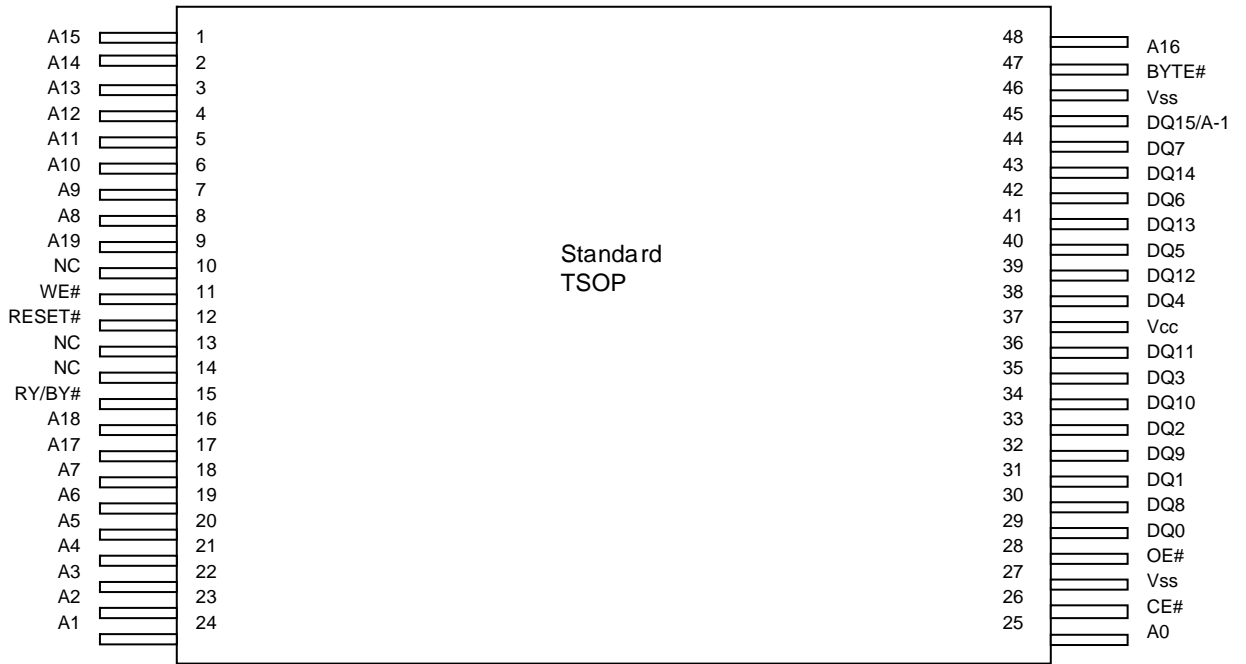

EN29LV160BB/EN29LV160BT Block Diagram

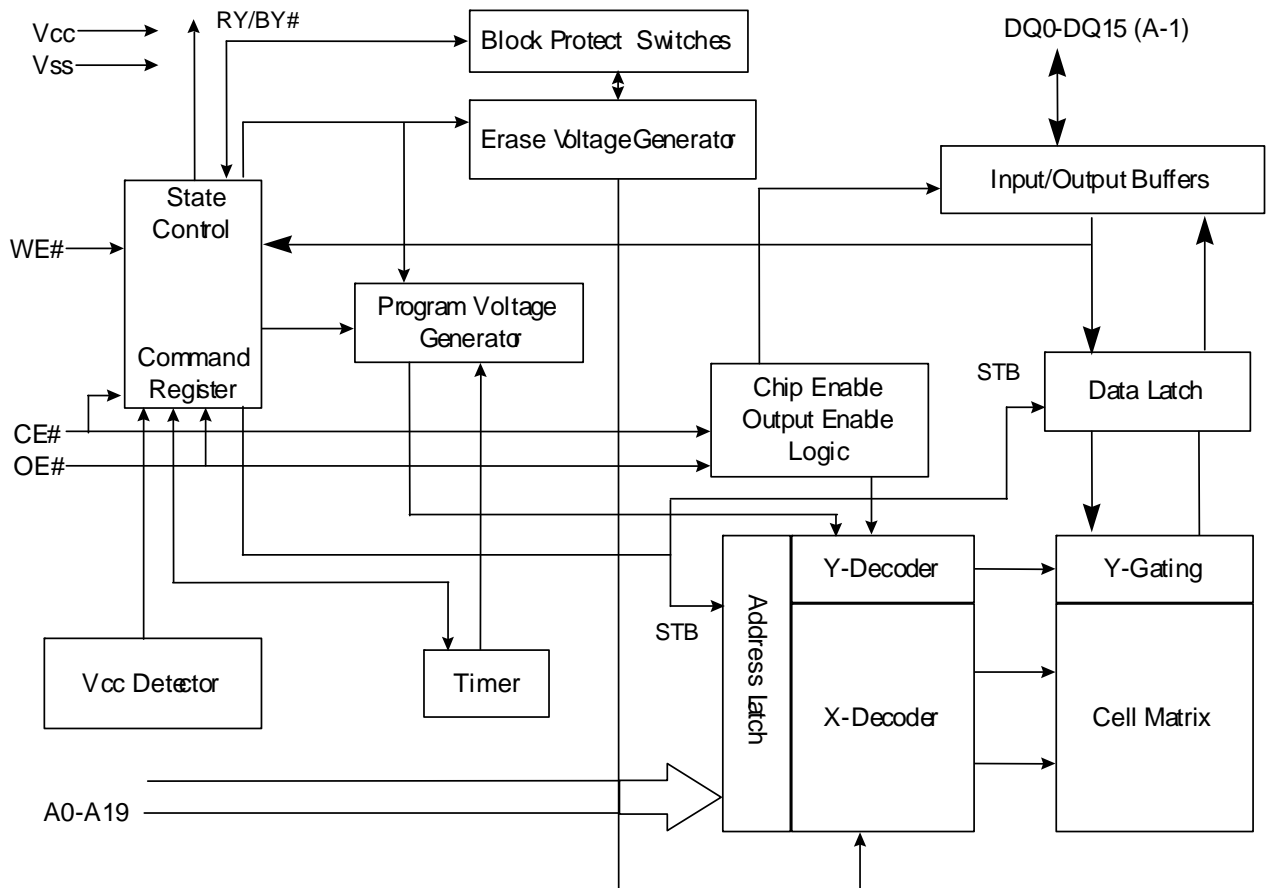

TCC8600 (HDMI : U2304)

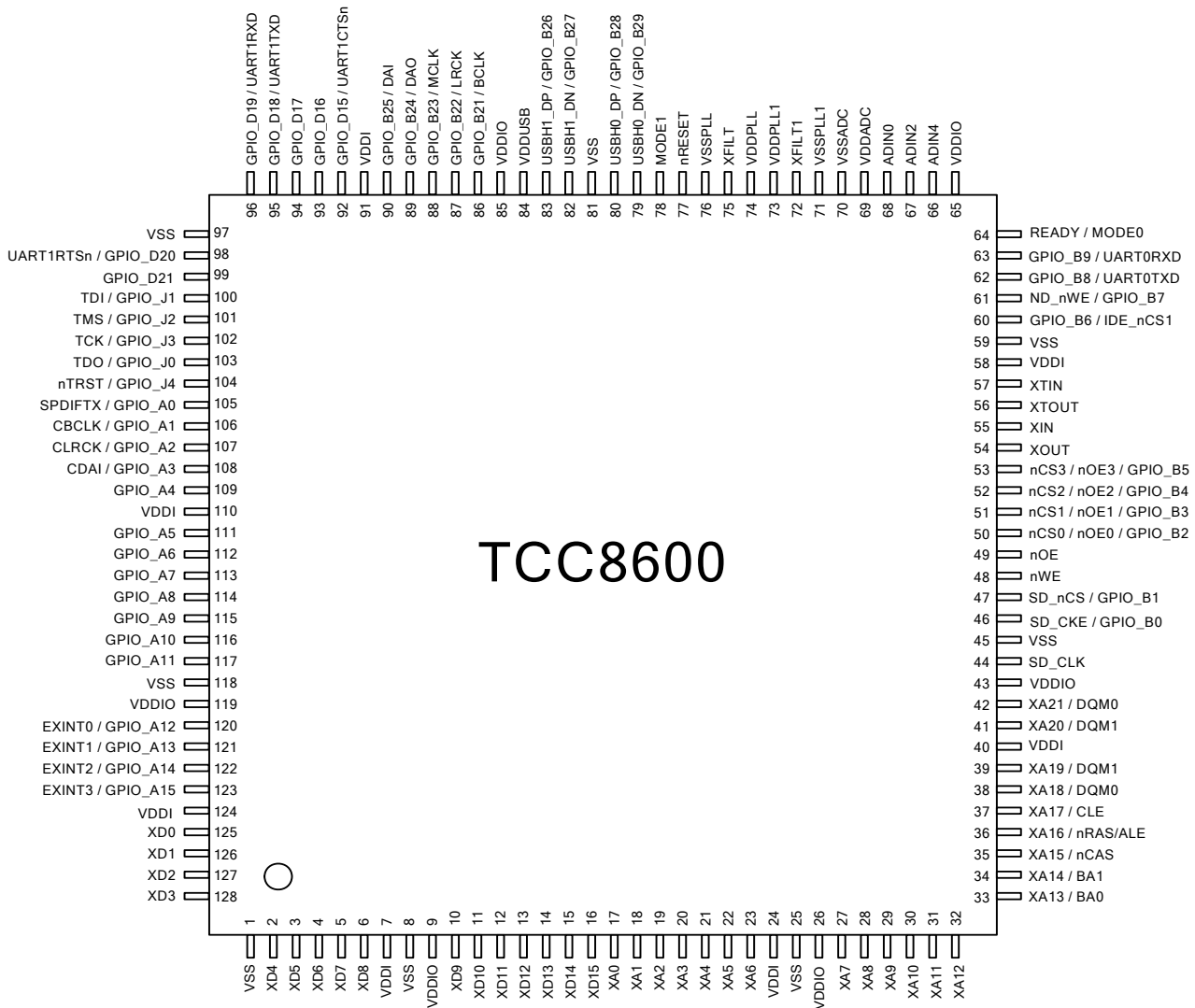

TCC8600 Block Diagram

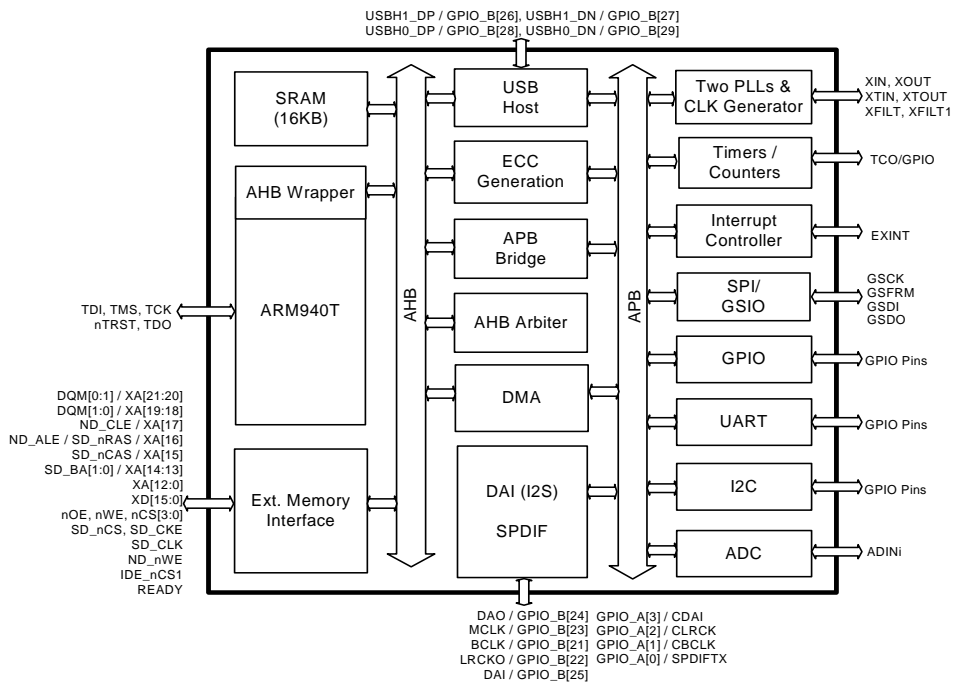

TCC8600 Pin Description

Signal Name	Pin#	Type	Description – TCC8600
SD_CLK	44	I/O	SDRAM Clock
SD_CKE / GPIO_B[0]	46	I/O	SDRAM Clock Enable signal. Active high. / GPIO_B[0]
SD_nCS / GPIO_B[1]	47	I/O	Chip select signal for SDRAM, Active low / GPIO_B[1]
XA[21] / DQM[0]	42	I/O	External Bus Address Bit [21] / Data I/O Mask 0
XA[20] / DQM[1]	41	I/O	External Bus Address Bit [20] / Data I/O Mask 1
XA[19] / DQM[1]	39	I/O	External Bus Address Bit [19] / Data I/O Mask 1
XA[18] / DQM[0]	38	I/O	External Bus Address Bit [18] / Data I/O Mask 0
XA[17] / ND_CLE	37	I/O	External Bus Address Bit [17] / CLE for NAND Flash
XA[16] / SD_nRAS / ND_ALE	36	I/O	External Bus Address Bit [16] / SDRAM RAS signal / ALE for NAND Flash
XA[15] / SD_nCAS	35	I/O	External Bus Address Bit [15] / SDRAM CAS signal
XA[14] / SD_BA[1]	34	I/O	External Bus Address Bit [14] / SDRAM Bank Address 1
XA[13] / SD_BA[0]	33	I/O	External Bus Address Bit [13] / SDRAM Bank Address 0.
XA[12]	32	I/O	External Bus Address Bit [12]
XA[11]	31	I/O	External Bus Address Bit [11]
XA[10]	30	I/O	External Bus Address Bit [10]
XA[9]	29	I/O	External Bus Address Bit [9]
XA[8]	28	I/O	External Bus Address Bit [8]
XA[7]	27	I/O	External Bus Address Bit [7]
XA[6]	23	I/O	External Bus Address Bit [6]
XA[5]	22	I/O	External Bus Address Bit [5]
XA[4]	21	I/O	External Bus Address Bit [4]
XA[3]	20	I/O	External Bus Address Bit [3]
XA[2]	19	I/O	External Bus Address Bit [2]
XA[1]	18	I/O	External Bus Address Bit [1]
XA[0]	17	I/O	External Bus Address Bit [0]
XD[15]	16	I/O	External Bus Data Bit [15]. Internal pull-up resistor enabled at reset.
XD[14]	15	I/O	External Bus Data Bit [14]. Internal pull-up resistor enabled at reset.
XD[13]	14	I/O	External Bus Data Bit [13]. Internal pull-up resistor enabled at reset.
XD[12]	13	I/O	External Bus Data Bit [12]. Internal pull-up resistor enabled at reset.
XD[11]	12	I/O	External Bus Data Bit [11]. Internal pull-up resistor enabled at reset.
XD[10]	11	I/O	External Bus Data Bit [10]. Internal pull-up resistor enabled at reset.
XD[9]	10	I/O	External Bus Data Bit [9]. Internal pull-up resistor enabled at reset.
XD[8]	6	I/O	External Bus Data Bit [8]. Internal pull-up resistor enabled at reset.
XD[7]	5	I/O	External Bus Data Bit [7]. Internal pull-up resistor enabled at reset.
XD[6]	4	I/O	External Bus Data Bit [6]. Internal pull-up resistor enabled at reset.
XD[5]	3	I/O	External Bus Data Bit [5]. Internal pull-up resistor enabled at reset.
XD[4]	2	I/O	External Bus Data Bit [4]. Internal pull-up resistor enabled at reset.
XD[3]	128	I/O	External Bus Data Bit [3]. Internal pull-up resistor enabled at reset.
XD[2]	127	I/O	External Bus Data Bit [2]. Internal pull-up resistor enabled at reset.
XD[1]	126	I/O	External Bus Data Bit [1]. Internal pull-up resistor enabled at reset.
XD[0]	125	I/O	External Bus Data Bit [0]. Internal pull-up resistor enabled at reset.
nWE	48	I/O	Static Memory Write Enable signal. Active low.
nOE	49	I/O	Static Memory Output Enable signal. Active low.
ND_nWE / GPIO_B[7]	61	I/O	NAND flash WE. Active low. / GPIO_B[7]
nCS[3] / ND_nOE[3] / GPIO_B[5]	53	I/O	External Bus Chip Select [3] / NAND Flash Output Enable [3] / GPIO_B[5]
nCS[2] / ND_nOE[2] / GPIO_B[4]	52	I/O	External Bus Chip Select [2] / NAND Flash Output Enable [2] / GPIO_B[4]
nCS[1] / ND_nOE[1] / GPIO_B[3]	51	I/O	External Bus Chip Select [1] / NAND Flash Output Enable [1] / GPIO_B[3]
nCS[0] / ND_nOE[0] / GPIO_B[2]	50	I/O	External Bus Chip Select [0] / NAND Flash Output Enable [0] / GPIO_B[2]
READY / MODE0	64	I	Ready information from external device.
USBH1_DP / GPIO_B[26]	83	I/O	USB Host Port 1 D+ signal / GPIO_B[26]
USBH1_DN / GPIO_B[27]	82	I/O	USB Host Port 1 D- signal / GPIO_B[27]
USBH0_DP / GPIO_B[28]	80	I/O	USB Host Port 0 D+ signal / GPIO_B[28]
USBH0_DN / GPIO_B[29]	79	I/O	USB Host Port 0 D- signal / GPIO_B[29]

Signal Name	Pin#	Type	Description – TCC8600
GPIO_A[15] / EXINT[3]	123	I/O	GPIO_A[15] / External Interrupt Request [3]
GPIO_A[14] / EXINT[2]	122	I/O	GPIO_A[14] / External Interrupt Request [2]
GPIO_A[13] / EXINT[1]	121	I/O	GPIO_A[13] / External Interrupt Request [1]
GPIO_A[12] / EXINT[0]	120	I/O	GPIO_A[12] / External Interrupt Request [0]
GPIO_A[11]	117	I/O	GPIO_A[11] / I2C Clock / GPSB/GSIO3 Data In
GPIO_A[10]	116	I/O	GPIO_A[10] / I2C Data Line / GPSB/GSIO3 FRM
GPIO_A[9]	115	I/O	GPIO_A[9] / I2C Clock./ Bus Width (BW) / GPSB/GSIO3 Clock
GPIO_A[8]	114	I/O	GPIO_A[8] / I2C Data Line / GPSB/GSIO3 Data Output
GPIO_A[7]	113	I/O	GPIO_A[7] / GPSB/GSIO1 Data In
GPIO_A[6]	112	I/O	GPIO_A[6] / GPSB/GSIO1 FRM
GPIO_A[5]	111	I/O	GPIO_A[5] / GPSB/GSIO1 Clock
GPIO_A[4]	109	I/O	GPIO_A[4] / GPSB/GSIO1 Data Output
GPIO_A[3] / CDAI	108	I/O	CD Data Input / GPIO_A[3] / GPSB/GSIO1 Data In
GPIO_A[2] / CLRCK	107	I/O	CD Data Word Clock Input / GPIO_A[2] / GPSB/GSIO1 FRM
GPIO_A[1] / CBCLK	106	I/O	CD Data Bit Clock Input / GPIO_A[1] / GPSB/GSIO1 Clock
GPIO_A[0] / SPDIFTX	105	I/O	GPIO_A[0] / SPDIF TX Output / GPSB/GSIO1 Data Output
GPIO_B[25] / DAI	90	I/O	I2S Digital Audio data Input / GPIO_B[25]
GPIO_B[24] / DAO	89	I/O	I2S Digital Audio data Output / GPIO_B[24] / Boot Mode Bit 2 (BM[2])
GPIO_B[23] / MCLK	88	I/O	I2S System Clock / GPIO_B[23]
GPIO_B[22] / LRCK	87	I/O	I2S Word Clock / GPIO_B[22] / Boot Mode Bit 1 (BM[1])
GPIO_B[21] / BCLK	86	I/O	I2S Bit Clock / GPIO_B[21] / Boot Mode Bit 0 (BM[0])
GPIO_B[9] / UART0RXD	63	I/O	GPIO_B[9] / UART0 RX Data
GPIO_B[8] / UART0TXD	62	I/O	GPIO_B[8] / UART0 TX Data
GPIO_B[6] / IDE_nCS1	60	I/O	GPIO_B[6] / Chip select 1 for IDE Interface. Internal pull-up resistor enabled at reset.
GPIO_D[21]	99	I/O	GPIO_D[21]. Internal pull-up resistor enabled at reset.
GPIO_D[20] / UART1RTSn	98	I/O	GPIO_D[20] / UART1 RTS Output (active low). Internal pull-up resistor enabled at reset.
GPIO_D[19] / UART1RXD	96	I/O	GPIO_D[19] / UART1 RX Data. Internal pull-up resistor enabled at reset.
GPIO_D[18] / UART1TXD	95	I/O	GPIO_D[18] / UART1 TX Data. Internal pull-up resistor enabled at reset.
GPIO_D[17]	94	I/O	GPIO_D[17] / I2C SCL
GPIO_D[16]	93	I/O	GPIO_D[16] / I2C SDA
GPIO_D[15] / UART1CTSn	92	I/O	GPIO_D[15] / UART1 CTS Input (active low)
ADIN0	68	AI	General purpose multi-channel ADC input 0
ADIN2	67	AI	General purpose multi-channel ADC input 2
ADIN4	66	AI	General purpose multi-channel ADC input 4
XIN	55	I	12MHz Crystal Oscillator Input. Voltage must not exceed VDDI (1.95V).
XOUT	54	O	12MHz Crystal Oscillator Output
XTIN	57	I	32.768kHz Crystal Oscillator Input.Voltage must not exceed VDDI (1.95V).
XTOUT	56	O	32.768kHz Crystal Oscillator Output
XFILT	75	AO	PLL0 filter output. 350pF capacitor is required.
XFILT1	72	AO	PLL1 filter output. 1200pF capacitor is required.
TDI / GPIO_J[1]	100	I/O	JTAG serial data input. Internal pull-up resistor is enabled at reset
TMS / GPIO_J[2]	101	I/O	JTAG test mode select. Internal pull-up resistor is enabled at reset
TCK / GPIO_J[3]	102	I/O	JTAG test clock. Internal pull-up resistor is enabled at reset
TDO / GPIO_J[0]	103	I/O	JTAG serial data output. Internal pull-up resistor is enabled at reset
nTRST / GPIO_J[4]	104	I/O	JTAG reset signal. Active low.. Internal pull-up resistor is enabled at reset
MODE1	78	I	Mode Setting Input 1. Pull-down for normal operation.
nRESET	77	I	System Reset. Active low.
VDDIO	9	PWR	Digital Power for I/O (3.3V)
VDDIO	26	PWR	Digital Power for I/O (3.3V)
VDDIO	43	PWR	Digital Power for I/O (3.3V)
VDDIO	65	PWR	Digital Power for I/O (3.3V)
VDDIO	85	PWR	Digital Power for I/O (3.3V)
VDDIO	119	PWR	Digital Power for I/O (3.3V)
VDDUSB	84	PWR	Power for USB I/O (3.3V)
VDDI	7	PWR	Digital Power for Internal Core (1.8V)
VDDI	24	PWR	Digital Power for Internal Core (1.8V)
VDDI	40	PWR	Digital Power for Internal Core (1.8V)

Signal Name	Pin#	Type	Description – TCC8600
VDDI	58	PWR	Digital Power for Internal Core (1.8V)
VDDI	91	PWR	Digital Power for Internal Core (1.8V)
VDDI	110	PWR	Digital Power for Internal Core (1.8V)
VDDI	124	PWR	Digital Power for Internal Core (1.8V)
VDDADC	69	PWR	Analog Power for ADC (3.3V)
VDDPLL	74	PWR	Analog & Digital Power for PLL (1.8V)
VDDPLL1	73	PWR	Analog & Digital Power for PLL1 (1.8V)
VSS	1	GND	Digital Ground
VSS	8	GND	Digital Ground
VSS	25	GND	Digital Ground
VSS	45	GND	Digital Ground
VSS	59	GND	Digital Ground
VSS	81	GND	Digital Ground
VSS	97	GND	Digital Ground
VSS	118	GND	Digital Ground
VSSADC	70	GND	Analog Ground for ADC
VSSPLL	76	GND	Analog Ground for PLL
VSSPLL1	71	GND	Analog Ground for PLL

TCC8600 Pin Description in Pin Number Order

Pin#	Signal Name	Type	Description – TCC8600
1	VSS	GND	Digital Ground
2	XD[4]	I/O	External Bus Data Bit [4]. Internal pull-up resistor enabled at reset.
3	XD[5]	I/O	External Bus Data Bit [5]. Internal pull-up resistor enabled at reset.
4	XD[6]	I/O	External Bus Data Bit [6]. Internal pull-up resistor enabled at reset.
5	XD[7]	I/O	External Bus Data Bit [7]. Internal pull-up resistor enabled at reset.
6	XD[8]	I/O	External Bus Data Bit [8]. Internal pull-up resistor enabled at reset.
7	VDDI	PWR	Digital Power for Internal Core (1.8V)
8	VSS	GND	Digital Ground
9	VDDIO	PWR	Digital Power for I/O (3.3V)
10	XD[9]	I/O	External Bus Data Bit [9]. Internal pull-up resistor enabled at reset.
11	XD[10]	I/O	External Bus Data Bit [10]. Internal pull-up resistor enabled at reset.
12	XD[11]	I/O	External Bus Data Bit [11]. Internal pull-up resistor enabled at reset.
13	XD[12]	I/O	External Bus Data Bit [12]. Internal pull-up resistor enabled at reset.
14	XD[13]	I/O	External Bus Data Bit [13]. Internal pull-up resistor enabled at reset.
15	XD[14]	I/O	External Bus Data Bit [14]. Internal pull-up resistor enabled at reset.
16	XD[15]	I/O	External Bus Data Bit [15]. Internal pull-up resistor enabled at reset.
17	XA[0]	I/O	External Bus Address Bit [0]
18	XA[1]	I/O	External Bus Address Bit [1]
19	XA[2]	I/O	External Bus Address Bit [2]
20	XA[3]	I/O	External Bus Address Bit [3]
21	XA[4]	I/O	External Bus Address Bit [4]
22	XA[5]	I/O	External Bus Address Bit [5]
23	XA[6]	I/O	External Bus Address Bit [6]
24	VDDI	PWR	Digital Power for Internal Core (1.8V)
25	VSS	GND	Digital Ground
26	VDDIO	PWR	Digital Power for I/O (3.3V)
27	XA[7]	I/O	External Bus Address Bit [7]
28	XA[8]	I/O	External Bus Address Bit [8]
29	XA[9]	I/O	External Bus Address Bit [9]
30	XA[10]	I/O	External Bus Address Bit [10]
31	XA[11]	I/O	External Bus Address Bit [11]
32	XA[12]	I/O	External Bus Address Bit [12]
33	XA[13] / SD_BA[0]	I/O	External Bus Address Bit [13] / SDRAM Bank Address 0.
34	XA[14] / SD_BA[1]	I/O	External Bus Address Bit [14] / SDRAM Bank Address 1
35	XA[15] / SD_nCAS	I/O	External Bus Address Bit [15] / SDRAM CAS signal

Pin#	Signal Name	Type	Description – TCC8600
36	XA[16] / SD_nRAS / ND_ALE	I/O	External Bus Address Bit [16] / SDRAM RAS signal / ALE for NAND Flash
37	XA[17] / ND_CLE	I/O	External Bus Address Bit [17] / CLE for NAND Flash
38	XA[18] / DQM[0]	I/O	External Bus Address Bit [18] / Data I/O Mask 0
39	XA[19] / DQM[1]	I/O	External Bus Address Bit [19] / Data I/O Mask 1
40	VDDI	PWR	Digital Power for Internal Core (1.8V)
41	XA[20] / DQM[1]	I/O	External Bus Address Bit [20] / Data I/O Mask 1
42	XA[21] / DQM[0]	I/O	External Bus Address Bit [21] / Data I/O Mask 0
43	VDDIO	PWR	Digital Power for I/O (3.3V)
44	SD_CLK	I/O	SDRAM Clock
45	VSS	GND	Digital Ground
46	SD_CKE / GPIO_B[0]	I/O	SDRAM Clock Enable signal. Active high. / GPIO_B[0]
47	SD_nCS / GPIO_B[1]	I/O	Chip select signal for SDRAM, Active low / GPIO_B[1]
48	nWE	I/O	Static Memory Write Enable signal. Active low.
49	nOE	I/O	Static Memory Output Enable signal. Active low.
50	nCS[0] / ND_nOE[0] / GPIO_B[2]	I/O	External Bus Chip Select [0] / NAND Flash Output Enable [0] / GPIO_B[2]
51	nCS[1] / ND_nOE[1] / GPIO_B[3]	I/O	External Bus Chip Select [1] / NAND Flash Output Enable [1] / GPIO_B[3]
52	nCS[2] / ND_nOE[2] / GPIO_B[4]	I/O	External Bus Chip Select [2] / NAND Flash Output Enable [2] / GPIO_B[4]
53	nCS[3] / ND_nOE[3] / GPIO_B[5]	I/O	External Bus Chip Select [3] / NAND Flash Output Enable [3] / GPIO_B[5]
54	XOUT	O	12MHz Crystal Oscillator Output
55	XIN	I	12MHz Crystal Oscillator Input. Voltage must not exceed VDDI (1.95V).
56	XTOUT	O	32.768kHz Crystal Oscillator Output
57	XTIN	I	32.768kHz Crystal Oscillator Input. Voltage must not exceed VDDI (1.95V).
58	VDDI	PWR	Digital Power for Internal Core (1.8V)
59	VSS	GND	Digital Ground
60	GPIO_B[6] / IDE_nCS1	I/O	GPIO_B[6] / Chip select 1 for IDE Interface. Internal pull-up resistor enabled at reset.
61	ND_nWE / GPIO_B[7]	I/O	NAND flash WE. Active low. / GPIO_B[7]
62	GPIO_B[8] / UART0TXD	I/O	GPIO_B[8] / UART0 TX Data
63	GPIO_B[9] / UART0RXD	I/O	GPIO_B[9] / UART0 RX Data
64	READY / MODE0	I	Ready information from external device.
65	VDDIO	PWR	Digital Power for I/O (3.3V)
66	ADIN4	AI	General purpose multi-channel ADC input 4
67	ADIN2	AI	General purpose multi-channel ADC input 2
68	ADIN0	AI	General purpose multi-channel ADC input 0
69	VDDADC	PWR	Analog Power for ADC (3.3V)
70	VSSADC	GND	Analog Ground for ADC
71	VSSPLL1	GND	Analog Ground for PLL
72	XFILT1	AO	PLL1 filter output. 1200pF capacitor is required.
73	VDDPLL1	PWR	Analog & Digital Power for PLL1 (1.8V)
74	VDDPLL	PWR	Analog & Digital Power for PLL (1.8V)
75	XFILT	AO	PLL0 filter output. 350pF capacitor is required.
76	VSSPLL	GND	Analog Ground for PLL
77	nRESET	I	System Reset. Active low.
78	MODE1	I	Mode Setting Input 1. Pull-down for normal operation.
79	USBH0_DN / GPIO_B[29]	I/O	USB Host Port 0 D- signal / GPIO_B[29]
80	USBH0_DP / GPIO_B[28]	I/O	USB Host Port 0 D+ signal / GPIO_B[28]
81	VSS	GND	Digital Ground
82	USBH1_DN / GPIO_B[27]	I/O	USB Host Port 1 D- signal / GPIO_B[27]
83	USBH1_DP / GPIO_B[26]	I/O	USB Host Port 1 D+ signal / GPIO_B[26]
84	VDDUSB	PWR	Power for USB I/O (3.3V)
85	VDDIO	PWR	Digital Power for I/O (3.3V)
86	GPIO_B[21] / BCLK	I/O	I2S Bit Clock / GPIO_B[21] / Boot Mode Bit 0 (BM[0])
87	GPIO_B[22] / LRCK	I/O	I2S Word Clock / GPIO_B[22] / Boot Mode Bit 1 (BM[1])
88	GPIO_B[23] / MCLK	I/O	I2S System Clock / GPIO_B[23]
89	GPIO_B[24] / DAO	I/O	I2S Digital Audio data Output / GPIO_B[24] / Boot Mode Bit 2 (BM[2])
90	GPIO_B[25] / DAI	I/O	I2S Digital Audio data Input / GPIO_B[25]
91	VDDI	PWR	Digital Power for Internal Core (1.8V)
92	GPIO_D[15] / UART1CTS _n	I/O	GPIO_D[15] / UART1 CTS Input (active low)
93	GPIO_D[16]	I/O	GPIO_D[16] / I2C SDA

Pin#	Signal Name	Type	Description – TCC8600
94	GPIO_D[17]	I/O	GPIO_D[17] / I2C SCL
95	GPIO_D[18] / UART1TXD	I/O	GPIO_D[18] / UART1 TX Data. Internal pull-up resistor enabled at reset.
96	GPIO_D[19] / UART1RXD	I/O	GPIO_D[19] / UART1 RX Data. Internal pull-up resistor enabled at reset.
97	VSS	GND	Digital Ground
98	GPIO_D[20] / UART1RTSn	I/O	GPIO_D[20] / UART1 RTS Output (active low). Internal pull-up resistor enabled at reset.
99	GPIO_D[21]	I/O	GPIO_D[21]. Internal pull-up resistor enabled at reset.
100	TDI / GPIO_J[1]	I/O	JTAG serial data input. Internal pull-up resistor is enabled at reset
101	TMS / GPIO_J[2]	I/O	JTAG test mode select. Internal pull-up resistor is enabled at reset
102	TCK / GPIO_J[3]	I/O	JTAG test clock. Internal pull-up resistor is enabled at reset
103	TDO / GPIO_J[0]	I/O	JTAG serial data output. Internal pull-up resistor is enabled at reset
104	nTRST / GPIO_J[4]	I/O	JTAG reset signal. Active low.. Internal pull-up resistor is enabled at reset
105	GPIO_A[0] / SPDIFTX	I/O	GPIO_A[0] / SPDIF TX Output / GPSB/GSIO1 Data Output
106	GPIO_A[1] / CBCLK	I/O	CD Data Bit Clock Input / GPIO_A[1] / GPSB/GSIO1 Clock
107	GPIO_A[2] / CLRCK	I/O	CD Data Word Clock Input / GPIO_A[2] / GPSB/GSIO1 FRM
108	GPIO_A[3] / CDAI	I/O	CD Data Input / GPIO_A[3] / GPSB/GSIO1 Data In
109	GPIO_A[4]	I/O	GPIO_A[4] / GPSB/GSIO1 Data Output
110	VDDI	PWR	Digital Power for Internal Core (1.8V)
111	GPIO_A[5]	I/O	GPIO_A[5] / GPSB/GSIO1 Clock
112	GPIO_A[6]	I/O	GPIO_A[6] / GPSB/GSIO1 FRM
113	GPIO_A[7]	I/O	GPIO_A[7] / GPSB/GSIO1 Data In
114	GPIO_A[8]	I/O	GPIO_A[8] / I2C Data Line / GPSB/GSIO3 Data Output
115	GPIO_A[9]	I/O	GPIO_A[9] / I2C Clock./ Bus Width (BW) / GPSB/GSIO3 Clock
116	GPIO_A[10]	I/O	GPIO_A[10] / I2C Data Line / GPSB/GSIO3 FRM
117	GPIO_A[11]	I/O	GPIO_A[11] / I2C Clock / GPSB/GSIO3 Data In
118	VSS	GND	Digital Ground
119	VDDIO	PWR	Digital Power for I/O (3.3V)
120	GPIO_A[12] / EXINT[0]	I/O	GPIO_A[12] / External Interrupt Request [0]
121	GPIO_A[13] / EXINT[1]	I/O	GPIO_A[13] / External Interrupt Request [1]
122	GPIO_A[14] / EXINT[2]	I/O	GPIO_A[14] / External Interrupt Request [2]
123	GPIO_A[15] / EXINT[3]	I/O	GPIO_A[15] / External Interrupt Request [3]
124	VDDI	PWR	Digital Power for Internal Core (1.8V)
125	XD[0]	I/O	External Bus Data Bit [0]. Internal pull-up resistor enabled at reset.
126	XD[1]	I/O	External Bus Data Bit [1]. Internal pull-up resistor enabled at reset.
127	XD[2]	I/O	External Bus Data Bit [2]. Internal pull-up resistor enabled at reset.
128	XD[3]	I/O	External Bus Data Bit [3]. Internal pull-up resistor enabled at reset.

IS42S16400F-6TL (HDMI : U1303, U2302)

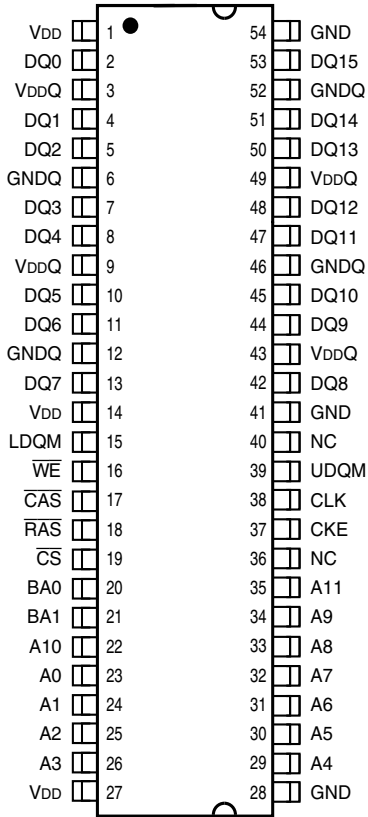

PIN DESCRIPTIONS

A0-A11	Row Address Input
A0-A7	Column Address Input
BA0, BA1	Bank Select Address
DQ0 to DQ15	Data I/O
CLK	System Clock Input
CKE	Clock Enable
CS	Chip Select
RAS	Row Address Strobe Command
CAS	Column Address Strobe Command
WE	Write Enable
LDQM	x16 Lower Byte, Input/Output Mask
UDQM	x16 Upper Byte, Input/Output Mask
VDD	Power
GND	Ground
VDDQ	Power Supply for I/O Pin
GNDQ	Ground for I/O Pin
NC	No Connection

IS42S16400F-6TL Block Diagram

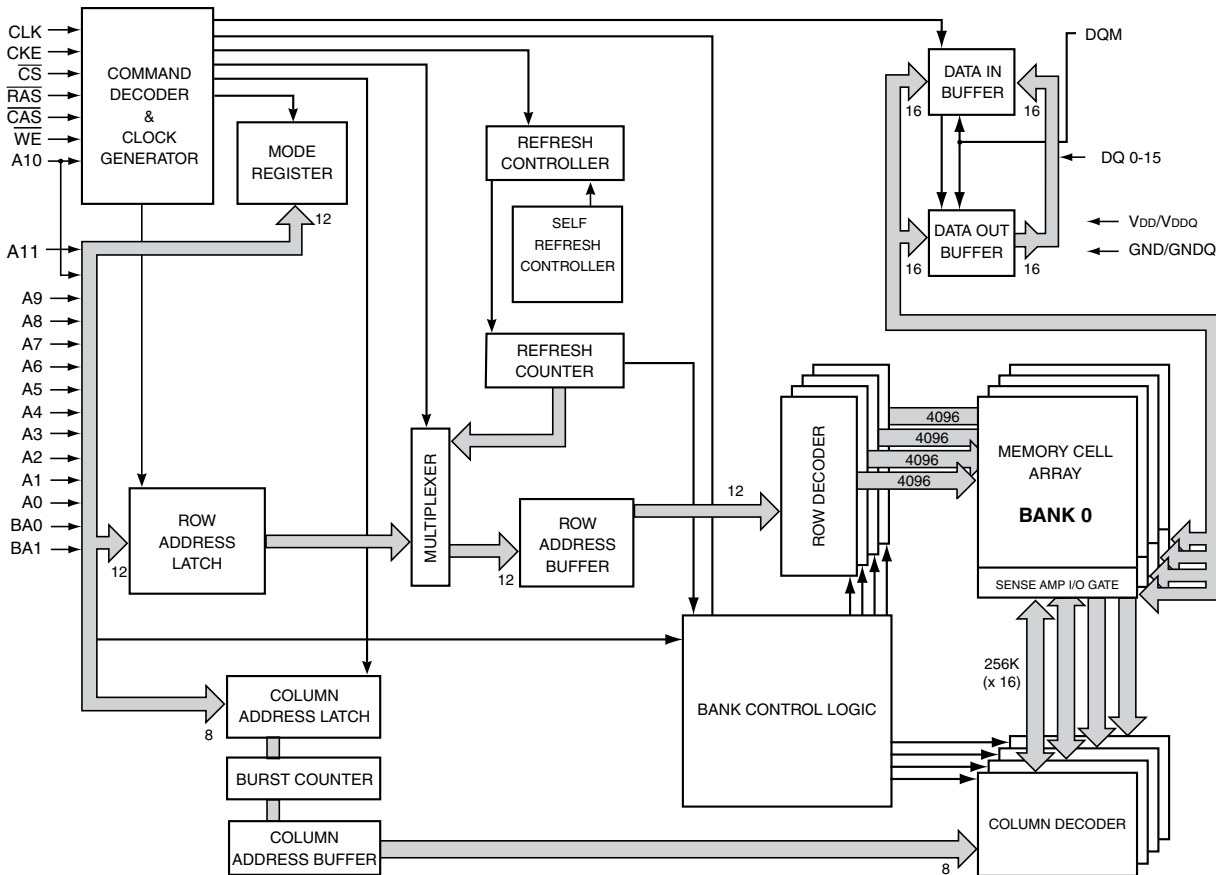

AK4424ET (HDMI : U2305)

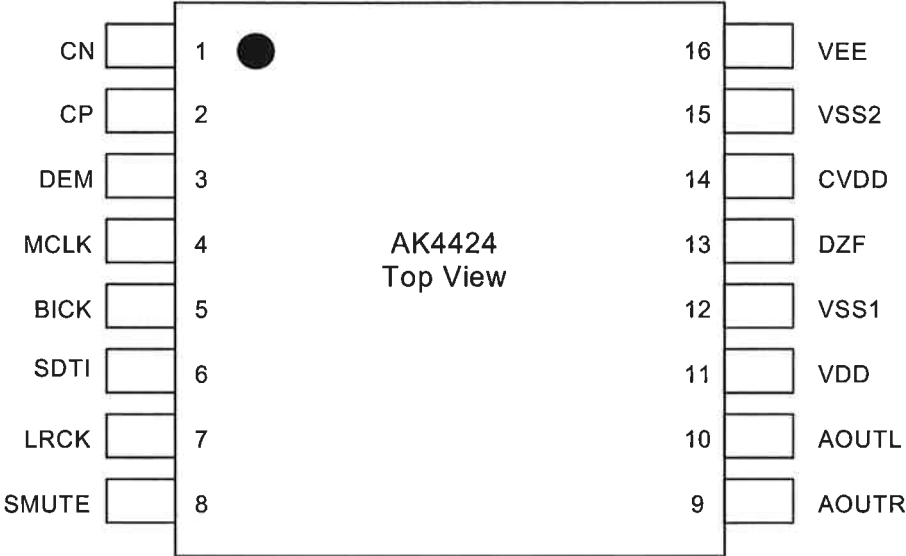

AK4424ET Block Diagram

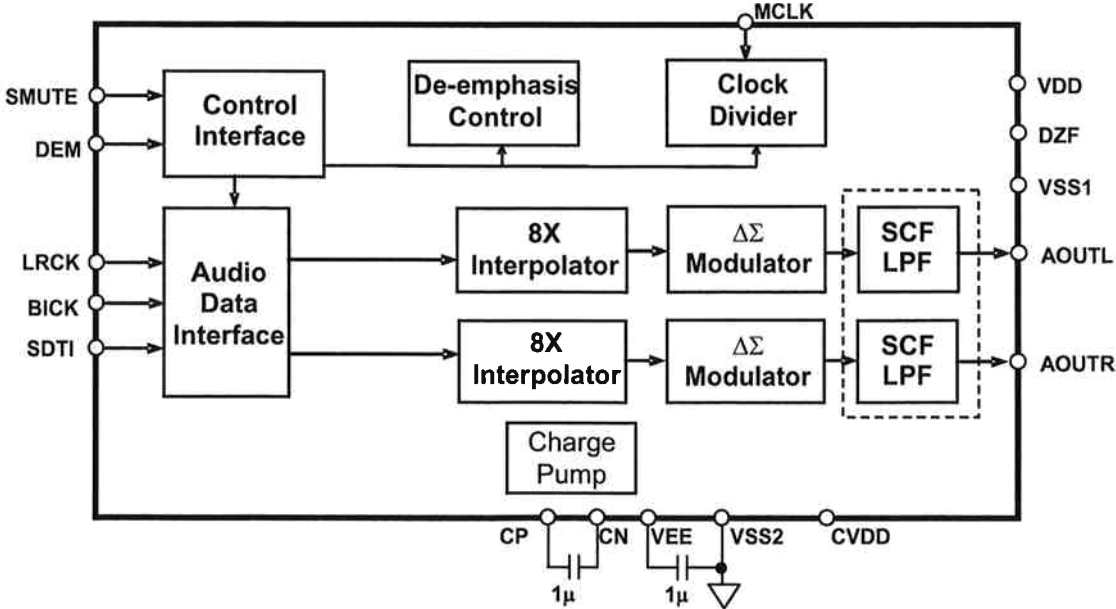

AK4358VQ (HDMI : U2102)

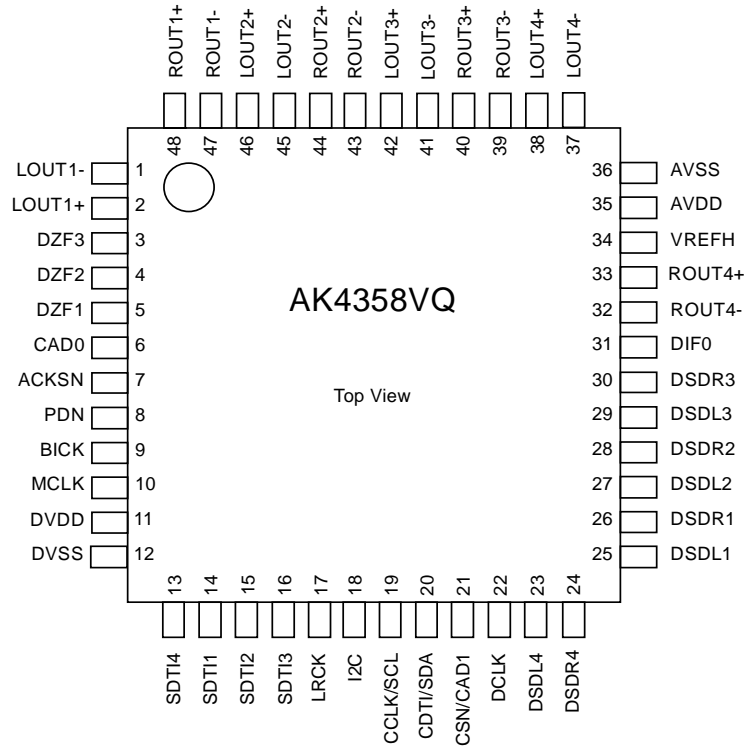

AK4358VQ Pin Function

No.	Pin Name	I/O	Function
1	LOUT1-	O	DAC1 Lch Negative Analog Output Pin
2	LOUT1+	O	DAC1 Lch Positive Analog Output Pin
3	DZF3	O	Zero Input Detect 3 Pin
4	DZF2	O	Zero Input Detect 2 Pin
5	DZF1	O	Zero Input Detect 1 Pin
6	CAD0	I	Chip Address 0 Pin
7	ACKSN	I	Auto Setting Mode Disable Pin (Pull-down Pin) “L”: Auto Setting Mode, “H”: Manual Setting Mode
8	PDN	I	Power-Down Mode Pin When at “L”, the AK4358 is in the power-down mode and is held in reset. The AK4358 should always be reset upon power-up.
9	BICK	I	Audio Serial Data Clock Pin
10	MCLK	I	Master Clock Input Pin An external TTL clock should be input on this pin.
11	DVDD	-	Digital Power Supply Pin, +4.75~+5.25V
12	DVSS	-	Digital Ground Pin
13	SDTI4	I	DAC4 Audio Serial Data Input Pin
14	SDTI1	I	DAC1 Audio Serial Data Input Pin
15	SDTI2	I	DAC2 Audio Serial Data Input Pin
16	SDTI3	I	DAC3 Audio Serial Data Input Pin
17	LRCK	I	L/R Clock Pin
18	I2C	I	Control Mode Select Pin “L”: 3-wire Serial, “H”: I ² C Bus
19	CCLK/SCL	I	Control Data Clock Pin I2C = “L”: CCLK (3-wire Serial), I2C = “H”: SCL (I ² C Bus)
20	CDTI/SDA	I/O	Control Data Input Pin I2C = “L”: CDTI (3-wire Serial), I2C = “H”: SDA (I ² C Bus)
21	CSN/CAD1	I	Chip Select Pin I2C = “L”: CSN (3-wire Serial), I2C = “H”: CAD1 (I ² C Bus)
22	DCLK	I	DSD Clock Pin
23	DSDL4	I	DAC4 DSD Lch Data Input Pin
24	DSDR4	I	DAC4 DSD Rch Data Input Pin
25	DSDL1	I	DAC1 DSD Lch Data Input Pin
26	DSDR1	I	DAC1 DSD Rch Data Input Pin
27	DSDL2	I	DAC2DSD Lch Data Input Pin
28	DSDR2	I	DAC2 DSD Rch Data Input Pin

29	DSDL3	I	DAC3 DSD Lch Data Input Pin
30	DSDR3	I	DAC3 DSD Rch Data Input Pin
31	DIF0	I	Audio Data Interface Format 0 Pin
32	ROUT4-	O	DAC4 Rch Negative Analog Output Pin
33	ROUT4+	O	DAC4 Rch Positive Analog Output Pin
34	VREFH	I	Positive Voltage Reference Input Pin
35	AVDD	-	Analog Power Supply Pin, +4.75~+5.25V
36	AVSS	-	Analog Ground Pin
37	LOUT4-	O	DAC4 Lch Negative Analog Output Pin
38	LOUT4+	O	DAC4 Lch Positive Analog Output Pin
39	ROUT3-	O	DAC3 Rch Negative Analog Output Pin
40	ROUT3+	O	DAC3 Rch Positive Analog Output Pin
41	LOUT3-	O	DAC3 Lch Negative Analog Output Pin
42	LOUT3+	O	DAC3 Lch Positive Analog Output Pin
43	ROUT2-	O	DAC2 Rch Negative Analog Output Pin
44	ROUT2+	O	DAC2 Rch Positive Analog Output Pin
45	LOUT2-	O	DAC2 Lch Negative Analog Output Pin
46	LOUT2+	O	DAC2 Lch Positive Analog Output Pin
47	ROUT1-	O	DAC1 Rch Negative Analog Output Pin
48	ROUT1+	O	DAC1 Rch Positive Analog Output Pin

Note: All input pins except pull-down pin should not be left floating.

AK5358BET (HDMI : U2101)

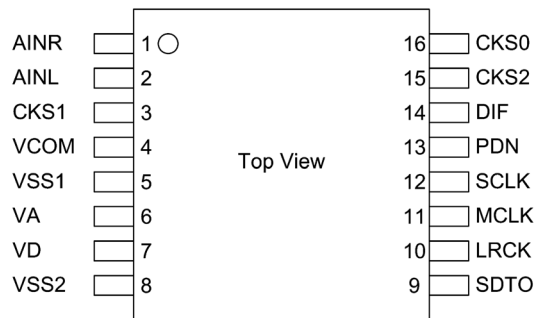

AK5358BET Pin Function

No.	Pin Name	I/O	Function
1	AINR	I	Rch Analog Input Pin
2	AINL	I	Lch Analog Input Pin
3	CKS1	I	Mode Select 1 Pin
4	VCOM	O	Common Voltage Output Pin, VA/2 Bias voltage of ADC input.
5	VSS1	-	Ground Pin
6	VA	-	Analog Power Supply Pin, 4.5 ~ 5.5V
7	VD	-	Digital Power Supply Pin, 2.7 ~ 5.5V
8	VSS2	-	Ground Pin
9	SDTO	O	Audio Serial Data Output Pin “L” Output at Power-down mode.
10	LRCK	I/O	Output Channel Clock Pin “L” Output in Master Mode at Power-down mode.
11	MCLK	I	Master Clock Input Pin
12	SCLK	I/O	Audio Serial Data Clock Pin “L” Output in Master Mode at Power-down mode.
13	PDN	I	Power Down Mode & Reset Pin “H”: Power up, “L”: Power down & Reset
14	DIF	I	Audio Interface Format Pin “H”: 24bit I ² S Compatible, “L”: 24bit MSB justified
15	CKS2	I	Mode Select 2 Pin
16	CKS0	I	Mode Select 0 Pin

R2A15220FP (AV : IC801)

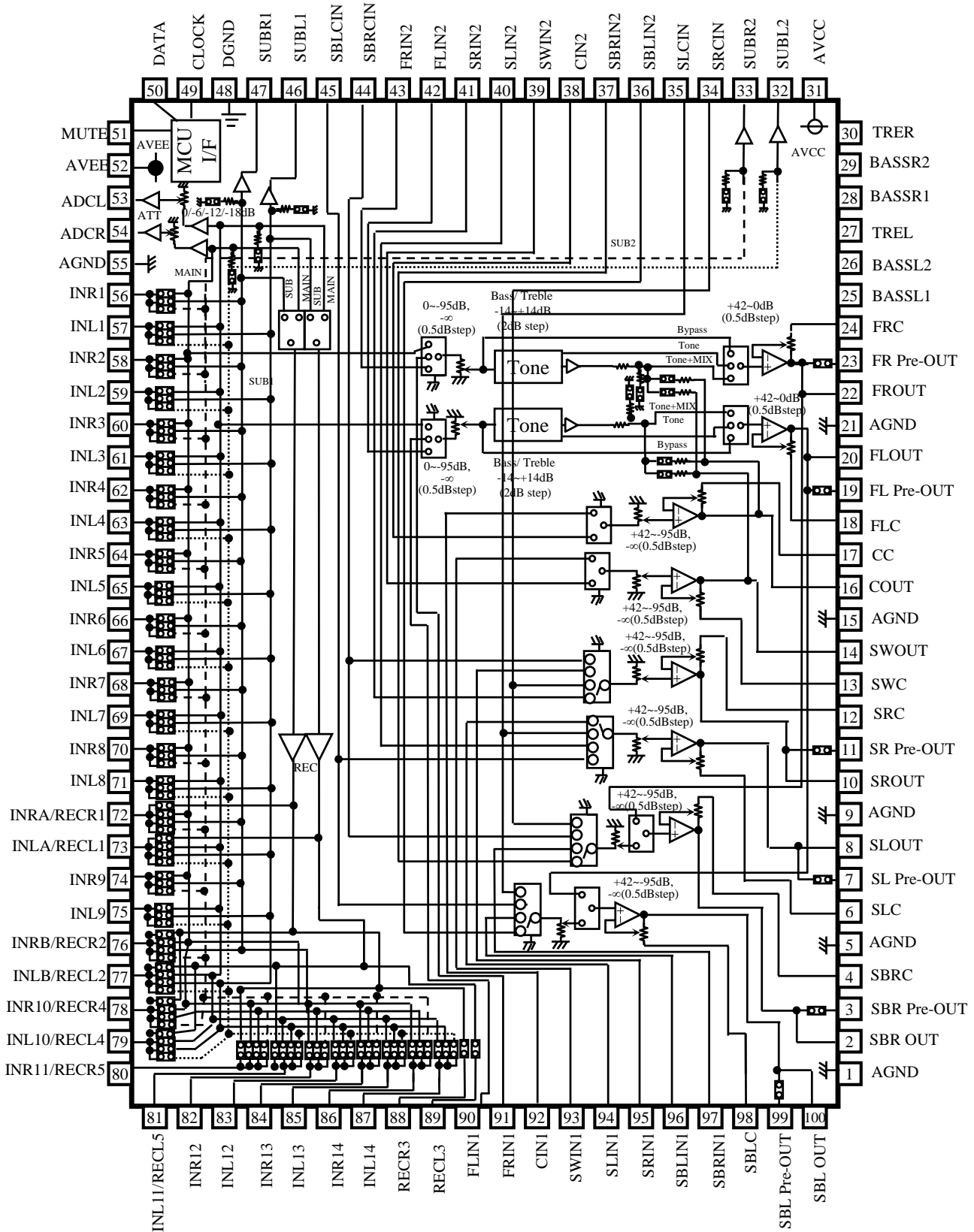

R2A15220FP Pin Function

PIN No.	Name	Function
22,20, 16,14, 10, 8, 2, 100	FROUT,FLOUT, COUT,SWOUT, SROUT, SLOUT, SBROUT,SBLOUT	Output pin of FL/FR/C/SW/SL/SR/SBL/SBR channel
23,19, 11, 7, 3, 99	FR Pre-out,FL Pre-out, SR Pre-out, SL Pre-out, SBR Pre-out,SBL Pre-out	Pre-output pin of FL/FR/SL/SR/SBL/SBR channel
24,18, 17,13, 12, 6, 4, 98	FRC,FLC, CC,SWC, SRC,SLC, SBRC,SBLC	Connects capacitor for reducing click noise of L/R/C/SW/SL/SR/SBL/SBR channel volume
1,5,9,15, 21,55,98	AGND	Analog ground of internal circuit
27,30	TREL, TRER	Frequency characteristic setting pin of L/R channel tone control (Treble)
25,26, 28,29	BASSL1,BASSL2 BASSR1,BASSR2	Frequency characteristic setting pin of L/R channel tone control (Bass)
31	AVCC	Positive power supply to internal circuit
43,42, 41,40, 39,38, 37,36	FRIN2, FLIN2, SRN2,SLIN2, SWIN2,CIN2, SBRIN2,SBLIN2	Multi Input pin of L/R/C/SW/SL/SR/SBL/SBR channel (Multi IN 1/2)
90,91, 92,93, 94,95, 96,97	FLIN1, FRIN1, CIN1,SWIN1, SLIN1,SRIN1, SBLIN1,SBRIN1	
48	DGND	Digital ground of internal circuit
49	DATA	Input pin of control data
50	CLOCK	Input pin of control clock
52	AVEE	Negative power supply to internal circuit
57,59,61,63, 65,67,69,71, 75,83,85,87	INL1,INL2, INL3,INL4, INL5,INL6,INL7,INL8, INL9,INL12,INL13,INL14	Input pin of L/R channel (Input Selector)
56,58,60,62, 64,66,68,70, 74,82,84,86	INR1,INR2, INR3,INR4, INR5,INR6,INR7,INR8, INR9,INR12,INR13,INR14	
51	MUTE	Outside Mute Control PIN
44,45 34,35	SBRCIN,SBLCIN SRCIN,SLCIN	3 rd Multi Input pin for SBL/SBR/SL/SR channel Volume that is able to swap SBR/SBL with SR/SL
46,47 33,32	SUBL1,SUBR1 SUBL2,SUBR2	Output pin for L/R channel SUB1/SUB2 Output
53,54	ADCL, ADCR	Output pin for L/R channel ADC
88,89	RECR3,RECL3	Output pin for L/R channel REC Output
72,73, 76,77, 78,79 80,81	INRA/RECR1,INLA/RECL1, INRB/RECR2,INLB/RECL2, INR10/RECR4,INL10/RECL4, INR11/RECR5,INL11/RECL5	Input pin of L/R channel (Input Selector)/ Output pin for L/R channel REC Output

EPM3032A (HDMI : U1707)

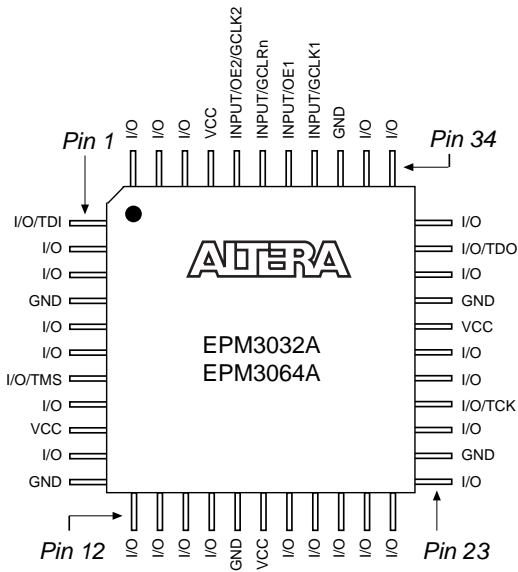

LC74781 (AV : IC810)

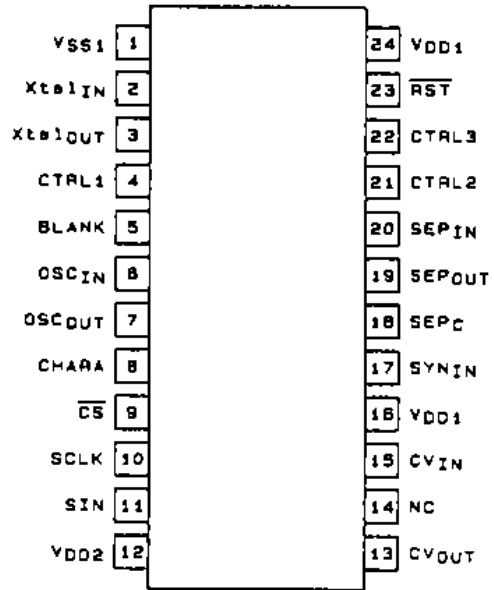

NJM2586AM (AV : IC811)

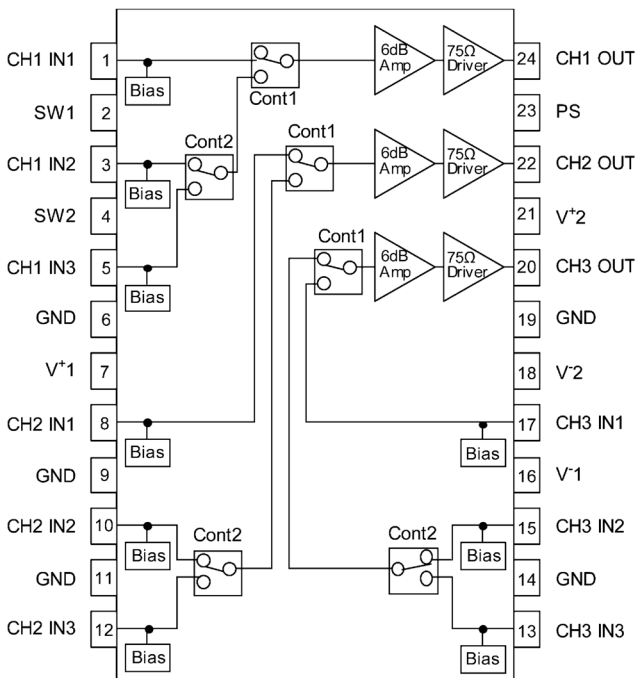

2. FL DISPLAY

FLD (18-ST-13GINK) (FRONT : U100)

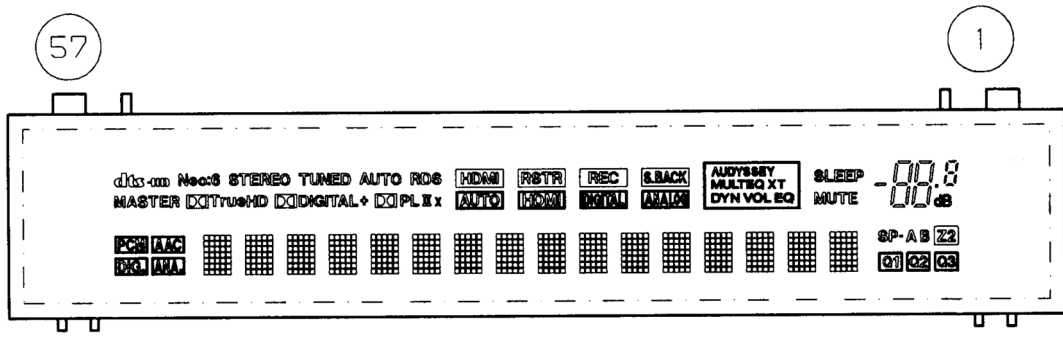

PIN CONNECTION

PIN NO.	5	5	5	5	5	5
	7	6	5	4	3	2
CONNECTION	F	N	N	N	N	V
	2	X	P	P	DL	LH

PIN NO.	5	4	4	4	4	4	4	4	4	3	3	3	3	3	3	3	2	2	2	2	2	2	2	1	1	1	1	1	1	1	1	8	7	6	5	4	3	2	1	
CONNECTION	V	D	S	S	C	C	C	C	T	T	N	N	N	N	N	N	N	N	N	N	N	N	N	N	N	N	N	N	N	N	N	N	1	1	1	1	1	1	1	1
	DS	OS	RESET	RESET	SPIA	SPIA	SPIA	SPIA	SPIA	SPIA	DA	DA	DA	DA	DA	DA	DA	DA	DA	DA	DA	DA	DA	DA	DA	DA	DA	DA	DA	DA	DA	8	7	6	5	4	3	2	1	
	DI	SI	RES	RES	CS	CS	CS	CS	CS	CP	DA	DA	DA	DA	DA	DA	DA	DA	DA	DA	DA	DA	DA	DA	DA	DA	DA	DA	DA	DA	8	7	6	5	4	3	2	1		

- NOTE
- 1) F1, F2 --- Filament
 - 2) NP ----- No pin
 - 3) DL ----- Datum Line
 - 4) NX ----- No extend pin
 - 5) GND ----- GND pin
 - 6) VFL ----- VFD Driving Voltage sink pin
 - 7) VDD ----- Logic Voltage Supply pin
 - 8) VDDH ----- VFD Driving Voltage Source pin
 - 9) CP ----- Shift Register Clock
 - 10) DA ----- Serial Data Input
 - 11) TSA, B --- Test pin
 - 12) CS ----- Chip Select Input pin
 - 13) RESET --- Reset Input
 - 14) OSC ----- Pin for self-oscillation
 - 15) Solder composition is Sn-3Ag-0.5Cu.
 - 16) 17G, 18G ----- Grid
 - 17) Q17G, Q18G ----- Driver Output Port.
 - 18) NC ----- No connection
(NC pin should be electrically open on the PC board.)
 - 19) Field of vision is a minimum of 21.8° from the lower side.

GRID ASSIGNMENT

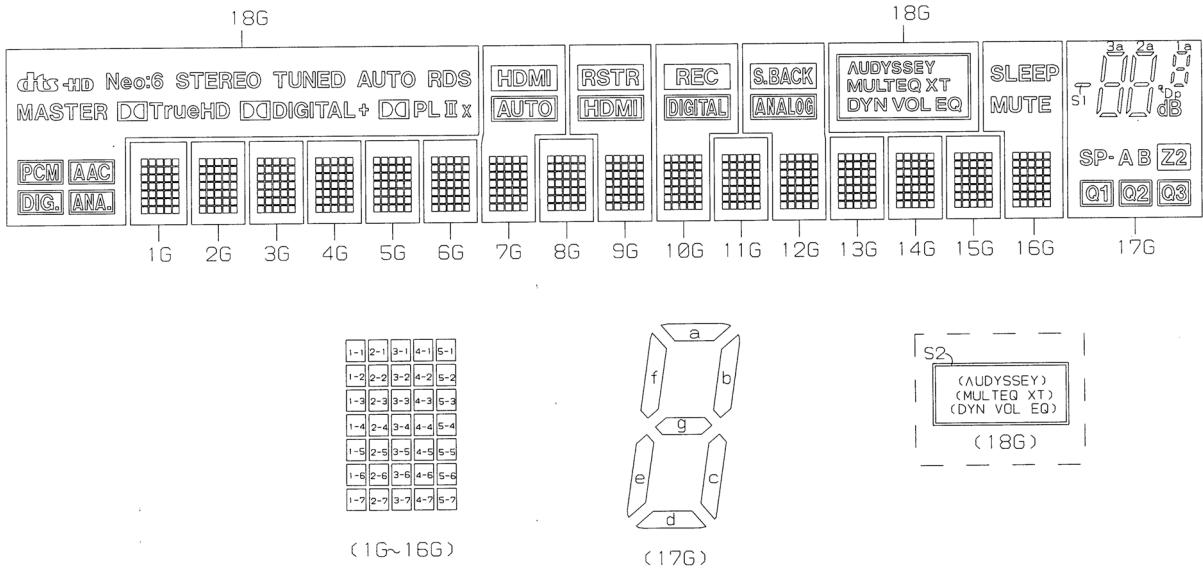

ANODE CONNECTION

	1G	2G	3G	4G	5G	6G	7G	8G	9G	10G	11G	12G	13G	14G	15G	16G	17G	18G
D0	1-1	1-1	1-1	1-1	1-1	1-1	1-1	1-1	1-1	1-1	1-1	1-1	1-1	1-1	1-1	1-1	S1	PCM
D1	2-1	2-1	2-1	2-1	2-1	2-1	2-1	2-1	2-1	2-1	2-1	2-1	2-1	2-1	2-1	2-1	3d	AAC
D2	3-1	3-1	3-1	3-1	3-1	3-1	3-1	3-1	3-1	3-1	3-1	3-1	3-1	3-1	3-1	3-1	2d	S2
D3	4-1	4-1	4-1	4-1	4-1	4-1	4-1	4-1	4-1	4-1	4-1	4-1	4-1	4-1	4-1	4-1	3e	EQ
D4	5-1	5-1	5-1	5-1	5-1	5-1	5-1	5-1	5-1	5-1	5-1	5-1	5-1	5-1	5-1	5-1	2e	VOL
D5	1-2	1-2	1-2	1-2	1-2	1-2	1-2	1-2	1-2	1-2	1-2	1-2	1-2	1-2	1-2	1-2	3c	DYN
D6	2-2	2-2	2-2	2-2	2-2	2-2	2-2	2-2	2-2	2-2	2-2	2-2	2-2	2-2	2-2	2-2	2c	XT
D7	3-2	3-2	3-2	3-2	3-2	3-2	3-2	3-2	3-2	3-2	3-2	3-2	3-2	3-2	3-2	3-2	3g	MULTEQ
D8	4-2	4-2	4-2	4-2	4-2	4-2	4-2	4-2	4-2	4-2	4-2	4-2	4-2	4-2	4-2	4-2	2g	AUDYSSEY
D9	5-2	5-2	5-2	5-2	5-2	5-2	5-2	5-2	5-2	5-2	5-2	5-2	5-2	5-2	5-2	5-2	3f	X
D10	1-3	1-3	1-3	1-3	1-3	1-3	1-3	1-3	1-3	1-3	1-3	1-3	1-3	1-3	1-3	1-3	2f	II
D11	2-3	2-3	2-3	2-3	2-3	2-3	2-3	2-3	2-3	2-3	2-3	2-3	2-3	2-3	2-3	2-3	3b	PL
D12	3-3	3-3	3-3	3-3	3-3	3-3	3-3	3-3	3-3	3-3	3-3	3-3	3-3	3-3	3-3	3-3	2b	DC (PL)
D13	4-3	4-3	4-3	4-3	4-3	4-3	4-3	4-3	4-3	4-3	4-3	4-3	4-3	4-3	4-3	4-3	3a	+
D14	5-3	5-3	5-3	5-3	5-3	5-3	5-3	5-3	5-3	5-3	5-3	5-3	5-3	5-3	5-3	5-3	2a	MASTER
D15	1-4	1-4	1-4	1-4	1-4	1-4	1-4	1-4	1-4	1-4	1-4	1-4	1-4	1-4	1-4	1-4	Dp	RDS
D16	2-4	2-4	2-4	2-4	2-4	2-4	2-4	2-4	2-4	2-4	2-4	2-4	2-4	2-4	2-4	2-4	dB	AUTO
D17	3-4	3-4	3-4	3-4	3-4	3-4	3-4	3-4	3-4	3-4	3-4	3-4	3-4	3-4	3-4	3-4	1d	TUNED
D18	4-4	4-4	4-4	4-4	4-4	4-4	4-4	4-4	4-4	4-4	4-4	4-4	4-4	4-4	4-4	4-4	1e	STEREO
D19	5-4	5-4	5-4	5-4	5-4	5-4	5-4	5-4	5-4	5-4	5-4	5-4	5-4	5-4	5-4	5-4	1c	Neo:6
D20	1-5	1-5	1-5	1-5	1-5	1-5	1-5	1-5	1-5	1-5	1-5	1-5	1-5	1-5	1-5	1-5	1g	+HD
D21	2-5	2-5	2-5	2-5	2-5	2-5	2-5	2-5	2-5	2-5	2-5	2-5	2-5	2-5	2-5	2-5	1f	dts
D22	3-5	3-5	3-5	3-5	3-5	3-5	3-5	3-5	3-5	3-5	3-5	3-5	3-5	3-5	3-5	3-5	1b	-
D23	4-5	4-5	4-5	4-5	4-5	4-5	4-5	4-5	4-5	4-5	4-5	4-5	4-5	4-5	4-5	4-5	1a	-
D24	5-5	5-5	5-5	5-5	5-5	5-5	5-5	5-5	5-5	5-5	5-5	5-5	5-5	5-5	5-5	5-5	SP-	-
D25	1-6	1-6	1-6	1-6	1-6	1-6	1-6	1-6	1-6	1-6	1-6	1-6	1-6	1-6	1-6	1-6	A	-
D26	2-6	2-6	2-6	2-6	2-6	2-6	2-6	2-6	2-6	2-6	2-6	2-6	2-6	2-6	2-6	2-6	B	-
D27	3-6	3-6	3-6	3-6	3-6	3-6	3-6	3-6	3-6	3-6	3-6	3-6	3-6	3-6	3-6	3-6	Z2	-
D28	4-6	4-6	4-6	4-6	4-6	4-6	4-6	4-6	4-6	4-6	4-6	4-6	4-6	4-6	4-6	4-6	Q1	-
D29	5-6	5-6	5-6	5-6	5-6	5-6	5-6	5-6	5-6	5-6	5-6	5-6	5-6	5-6	5-6	5-6	Q2	-
D30	1-7	1-7	1-7	1-7	1-7	1-7	1-7	1-7	1-7	1-7	1-7	1-7	1-7	1-7	1-7	1-7	Q3	-
D31	2-7	2-7	2-7	2-7	2-7	2-7	2-7	2-7	2-7	2-7	2-7	2-7	2-7	2-7	2-7	2-7	-	-
D32	3-7	3-7	3-7	3-7	3-7	3-7	3-7	3-7	3-7	3-7	3-7	3-7	3-7	3-7	3-7	3-7	-	-
D33	4-7	4-7	4-7	4-7	4-7	4-7	4-7	4-7	4-7	4-7	4-7	4-7	4-7	4-7	4-7	4-7	-	DIG.
D34	5-7	5-7	5-7	5-7	5-7	5-7	5-7	5-7	5-7	5-7	5-7	5-7	5-7	5-7	5-7	5-7	-	ANA.
AD1	-	-	-	-	-	-	AUTO	-	HDMI	MEMU	-	ANALOG	-	-	-	MUTE	-	DDIGITAL
AD2	-	-	-	-	-	-	HDMI	-	RSTR	REC	-	BACK	-	-	-	SLEEP	-	DDTTRUeHD

PARTS LIST OF P.C.B. UNIT

* Parts for which "nsp" is indicated on this table cannot be supplied.

* The parts listed below are for maintenance only, might differ from the parts used in the unit in appearances or dimensions.

Note: The symbols in the column "Remarks" indicate the following destinations.

1911E3 : U.S.A. & Canada model

1911E2 : Europe model

1911E1C : China model

791E3 : U.S.A. & Canada model

791EA : Australia model

BK : Black model

SP : Premium Silver model

PCB 7CH_AMP ASS'Y

Ref. No.	Part No.	Part Name	Remarks	Q'ty	New
SEMICONDUCTORS GROUP					
Q401	00D2710314903	TR 2SA KTA1024Y		J5001024Y0050S	
Q403	00D2710318909	TR 2SA 2N5401S		J520254010010S	
Q404	00D9960018706	TR 2SD2390-Y		J5032390Y0000S	
Q405	00D2710318909	TR 2SA 2N5401S		J520254010010S	
Q406	00D2730479909	TR 2SC 2N5551S		J522255510010S	
Q407,408	00D9600196302	TR KTA1268BL		J5001268B0050S	
Q409	963219003340S	TR 2SC KTC3964		J502396400010S	
Q410	00D9960018706	TR 2SB1560-Y		J5011560Y0000S	
Q412	00D2730471907	TR 2SC KTC3206Y		J5023206Y0050S	
Q413	00D2710314903	TR 2SA KTA1024Y		J5001024Y0050S	
Q415	00D2710318909	TR 2SA 2N5401S		J520254010010S	
Q416	00D9960018706	TR 2SD2390-Y		J5032390Y0000S	
Q417	00D9600196302	TR KTA1268BL		J5001268B0050S	
Q418	00D2730479909	TR 2SC 2N5551S		J522255510010S	
Q419,420	00D9600196302	TR KTA1268BL		J5001268B0050S	
Q421	963219003340S	TR 2SC KTC3964		J502396400010S	
Q422	00D9960018706	TR 2SB1560-Y		J5011560Y0000S	
Q424	00D2730471907	TR 2SC KTC3206Y		J5023206Y0050S	
Q425	00D2710314903	TR 2SA KTA1024Y		J5001024Y0050S	
Q427	00D2710318909	TR 2SA 2N5401S		J520254010010S	
Q428	00D9960018706	TR 2SD2390-Y		J5032390Y0000S	
Q430	00D2730479909	TR 2SC 2N5551S		J522255510010S	
Q431,432	00D9600196302	TR KTA1268BL		J5001268B0050S	
Q433	963219003340S	TR 2SC KTC3964		J502396400010S	
Q434	00D9960018706	TR 2SB1560-Y		J5011560Y0000S	
Q436	00D2730471907	TR 2SC KTC3206Y		J5023206Y0050S	
Q437	00D2710314903	TR 2SA KTA1024Y		J5001024Y0050S	
Q439	00D2710318909	TR 2SA 2N5401S		J520254010010S	
Q440	00D9960018706	TR 2SD2390-Y		J5032390Y0000S	
Q442	00D2730479909	TR 2SC 2N5551S		J522255510010S	
Q443,444	00D9600196302	TR KTA1268BL		J5001268B0050S	
Q445	963219003340S	TR 2SC KTC3964		J502396400010S	
Q446	00D9960018706	TR 2SB1560-Y		J5011560Y0000S	
Q448	00D2730471907	TR 2SC KTC3206Y		J5023206Y0050S	
Q449	00D2710314903	TR 2SA KTA1024Y		J5001024Y0050S	
Q451	00D2710318909	TR 2SA 2N5401S		J520254010010S	
Q452	00D9960018706	TR 2SD2390-Y		J5032390Y0000S	
Q454	00D2730479909	TR 2SC 2N5551S		J522255510010S	
Q455,456	00D9600196302	TR KTA1268BL		J5001268B0050S	
Q457	963219003340S	TR 2SC KTC3964		J502396400010S	
Q458	00D9960018706	TR 2SB1560-Y		J5011560Y0000S	
Q460	00D2730471907	TR 2SC KTC3206Y		J5023206Y0050S	
Q461	00D2710314903	TR 2SA KTA1024Y		J5001024Y0050S	

	Ref. No.	Part No.	Part Name	Remarks		Q'ty	New
	Q463	00D2710318909	TR 2SA 2N5401S		J520254010010S		
	Q464	00D9960018706	TR 2SD2390-Y		J5032390Y0000S		
	Q466	00D2730479909	TR 2SC 2N5551S		J522255510010S		
	Q467,468	00D9600196302	TR KTA1268BL		J5001268B0050S		
	Q469	963219003340S	TR 2SC KTC3964		J502396400010S		
	Q470	00D9960018706	TR 2SB1560-Y		J5011560Y0000S		
	Q472	00D2730471907	TR 2SC KTC3206Y		J5023206Y0050S		
	Q473	00D2710314903	TR 2SA KTA1024Y		J5001024Y0050S		
	Q475	00D2710318909	TR 2SA 2N5401S		J520254010010S		
	Q476	00D9960018706	TR 2SD2390-Y		J5032390Y0000S		
	Q478	00D2730479909	TR 2SC 2N5551S		J522255510010S		
	Q479,480	00D9600196302	TR KTA1268BL		J5001268B0050S		
	Q481	963219003340S	TR 2SC KTC3964		J502396400010S		
	Q482	00D9960018706	TR 2SB1560-Y		J5011560Y0000S		
	Q484	00D2730471907	TR 2SC KTC3206Y		J5023206Y0050S		
	D402-404	00D2760401905	D,SWITCHING 1SS133T		K000013300520S		
	D408-410	00D2760401905	D,SWITCHING 1SS133T		K000013300520S		
	D414-416	00D2760401905	D,SWITCHING 1SS133T		K000013300520S		
	D420-422	00D2760401905	D,SWITCHING 1SS133T		K000013300520S		
	D426-428	00D2760401905	D,SWITCHING 1SS133T		K000013300520S		
	D432-434	00D2760401905	D,SWITCHING 1SS133T		K000013300520S		
	D438-440	00D2760401905	D,SWITCHING 1SS133T		K000013300520S		
	ZD401	00D2760643983	D,ZENER MTZJ5.1A		K06005R134520S		
	ZD402,403	00D9630047502	D,ZENER MTZJ3.3B		K06003R344520S		
	ZD404	00D2760643983	D,ZENER MTZJ5.1A		K06005R134520S		
	ZD405,406	00D9630047502	D,ZENER MTZJ3.3B		K06003R344520S		
	ZD407	00D2760643983	D,ZENER MTZJ5.1A		K06005R134520S		
	ZD408,409	00D9630047502	D,ZENER MTZJ3.3B		K06003R344520S		
	ZD410	00D2760643983	D,ZENER MTZJ5.1A		K06005R134520S		
	ZD411,412	00D9630047502	D,ZENER MTZJ3.3B		K06003R344520S		
	ZD413	00D2760643983	D,ZENER MTZJ5.1A		K06005R134520S		
	ZD414,415	00D9630047502	D,ZENER MTZJ3.3B		K06003R344520S		
	ZD416	00D2760643983	D,ZENER MTZJ5.1A		K06005R134520S		
	ZD417,418	00D9630047502	D,ZENER MTZJ3.3B		K06003R344520S		
	ZD419	00D2760643983	D,ZENER MTZJ5.1A		K06005R134520S		
	ZD420,421	00D9630047502	D,ZENER MTZJ3.3B		K06003R344520S		
RESISTORS GROUP							
	R404	nsp	R,FIXED 1WJ-5.6K		N113135656220S		
	R406	963252004160S	POSISTOR 18BC471QB5RB		F320184710050S		
	R408	nsp	R,FIXED 1WJ-5.6K		N113135656220S		
	R415	963125012630S	R,METAL FILM 22-J,1W	FLAMERETARDANT	C060022065050S		
	R424,425	00D9630345903	R,FIXED 2WJ-0.47	FLAMERETARDANT	N113136647820S		
	R430,431	00D9630345903	R,FIXED 2WJ-0.47	FLAMERETARDANT	N113136647820S		
	R434	nsp	R,METAL FILM 3.3K-J,1W		C060033265050S		
	R439	963125012630S	R,METAL FILM 22-J,1W	FLAMERETARDANT	C060022065050S		
	R441	nsp	R,METAL FILM 1.2K-J,1W		C060012265050S		
	R443	nsp	R,METAL FILM 47-J,1W		C060047065060S		
	R445	nsp	R,FIXED 1WJ-5.6K		N113135656220S		
	R450	963252004160S	POSISTOR 18BC471QB5RB		F320184710050S		

Ref. No.	Part No.	Part Name	Remarks		Q'ty	New
R451	nsp	R,FIXED 1WJ-5.6K		N113135656220S		
R458	963125012630S	R,METAL FILM 22-J,1W	FLAMERETARDANT	C060022065050S		
R467,468	00D9630345903	R,FIXED 2WJ-0.47	FLAMERETARDANT	N113136647820S		
R474,475	00D9630345903	R,FIXED 2WJ-0.47	FLAMERETARDANT	N113136647820S		
R478	nsp	R,METAL FILM 3.3K-J,1W		C060033265050S		
R483	963125012630S	R,METAL FILM 22-J,1W	FLAMERETARDANT	C060022065050S		
R485	nsp	R,METAL FILM 1.2K-J,1W		C060012265050S		
R487	nsp	R,METAL FILM 47-J,1W		C060047065060S		
R489	nsp	R,FIXED 1WJ-5.6K		N113135656220S		
R493	00D9630337908	R,METAL 33-J,1W	FLAMERETARDANT	C060033065050S		
R494	963252004160S	POSISTOR 18BC471QB5RB		F320184710050S		
R495	nsp	R,FIXED 1WJ-5.6K		N113135656220S		
R502	963125012630S	R,METAL FILM 22-J,1W	FLAMERETARDANT	C060022065050S		
R511,512	00D9630345903	R,FIXED 2WJ-0.47	FLAMERETARDANT	N113136647820S		
R517,518	00D9630345903	R,FIXED 2WJ-0.47	FLAMERETARDANT	N113136647820S		
R521	nsp	R,METAL FILM 3.3K-J,1W		C060033265050S		
R526	963125012630S	R,METAL FILM 22-J,1W	FLAMERETARDANT	C060022065050S		
R528	nsp	R,METAL FILM 1.2K-J,1W		C060012265050S		
R530	nsp	R,METAL FILM 47-J,1W		C060047065060S		
R534	nsp	R,FIXED 1WJ-5.6K		N113135656220S		
R537	963252004160S	POSISTOR 18BC471QB5RB		F320184710050S		
R538	nsp	R,FIXED 1WJ-5.6K		N113135656220S		
R545	963125012630S	R,METAL FILM 22-J,1W	FLAMERETARDANT	C060022065050S		
R551	00D9639005639	R,METAL FILM 100-J,1W	FLAMERETARDANT	C060010165060S		
R554,555	00D9630345903	R,FIXED 2WJ-0.47	FLAMERETARDANT	N113136647820S		
R561,562	00D9630345903	R,FIXED 2WJ-0.47	FLAMERETARDANT	N113136647820S		
R564	nsp	R,METAL FILM 3.3K-J,1W		C060033265050S		
R569	963125012630S	R,METAL FILM 22-J,1W	FLAMERETARDANT	C060022065050S		
R571	nsp	R,METAL FILM 1.2K-J,1W		C060012265050S		
R573	nsp	R,METAL FILM 47-J,1W		C060047065060S		
R577	nsp	R,FIXED 1WJ-5.6K		N113135656220S		
R580	963252004160S	POSISTOR 18BC471QB5RB		F320184710050S		
R581	nsp	R,FIXED 1WJ-5.6K		N113135656220S		
R588	963125012630S	R,METAL FILM 22-J,1W	FLAMERETARDANT	C060022065050S		
R597,598	00D9630345903	R,FIXED 2WJ-0.47	FLAMERETARDANT	N113136647820S		
R603,604	00D9630345903	R,FIXED 2WJ-0.47	FLAMERETARDANT	N113136647820S		
R607	nsp	R,METAL FILM 3.3K-J,1W		C060033265050S		
R612	963125012630S	R,METAL FILM 22-J,1W	FLAMERETARDANT	C060022065050S		
R614	nsp	R,METAL FILM 1.2K-J,1W		C060012265050S		
R616	nsp	R,METAL FILM 47-J,1W		C060047065060S		
R620	nsp	R,FIXED 1WJ-5.6K		N113135656220S		
R623	963252004160S	POSISTOR 18BC471QB5RB		F320184710050S		
R624	nsp	R,FIXED 1WJ-5.6K		N113135656220S		
R631	963125012630S	R,METAL FILM 22-J,1W	FLAMERETARDANT	C060022065050S		
R640,641	00D9630345903	R,FIXED 2WJ-0.47	FLAMERETARDANT	N113136647820S		
R646,647	00D9630345903	R,FIXED 2WJ-0.47	FLAMERETARDANT	N113136647820S		
R650	nsp	R,METAL FILM 3.3K-J,1W		C060033265050S		
R655	963125012630S	R,METAL FILM 22-J,1W	FLAMERETARDANT	C060022065050S		
R657	nsp	R,METAL FILM 1.2K-J,1W		C060012265050S		
R659	nsp	R,METAL FILM 47-J,1W		C060047065060S		
R663	nsp	R,FIXED 1WJ-5.6K		N113135656220S		
R666	963252004160S	POSISTOR 18BC471QB5RB		F320184710050S		
R667	nsp	R,FIXED 1WJ-5.6K		N113135656220S		

Ref. No.	Part No.	Part Name	Remarks		Q'ty	New
R674	963125012630S	R,METAL FILM 22-J,1W	FLAMERETARDANT	C060022065050S		
R683,684	00D9630345903	R,FIXED 2WJ-0.47	FLAMERETARDANT	N113136647820S		
R689,690	00D9630345903	R,FIXED 2WJ-0.47	FLAMERETARDANT	N113136647820S		
R694	nsp	R,METAL FILM 3.3K-J,1W		C060033265050S		
R698	963125012630S	R,METAL FILM 22-J,1W	FLAMERETARDANT	C060022065050S		
R700	nsp	R,METAL FILM 1.2K-J,1W		C060012265050S		
R702	nsp	R,METAL FILM 47-J,1W		C060047065060S		
VR401-407	963161012400S	VR,SEMI CARBON EVN-DCAA03B 1KB		C541102315000S		

CAPACITORS GROUP

C401	nsp	C,CERAMIC 0.1UF-K/50V		D011104577160S		
C403	nsp	C,CERAMIC 0.01UF-K/50V		D010103777160S		
C404	00D9630234506	C,ELECT 47UF-M/50V (Pb Free)		D040470087070S		
C405	nsp	C,CERAMIC 100PF-J/50V		D010101167160S		
C406	nsp	C,CERAMIC SL220PF-J/500V		D00022106D051S		
C407	00D9630234506	C,ELECT 47UF-M/50V (Pb Free)		D040470087070S		
C408	00D9630224503	C,ELECT 22UF-M/50V		D040220087060S		
C410	00D9609009937	C,ELECT 100UF-M/50V		D040101087060S		
C412	nsp	C,CERAMIC 470PF-K/500V		D00447127D050S		
C413	nsp	C,CERAMIC X7R2200PF-K/50V		D011222777200S		
C415,416	00D9630234302	C,ELECT 10UF-M/100V		D04010008C050S		
C418	nsp	C,CERAMIC 0.1UF-K/50V		D011104577160S		
C419	00D9630324005	C,ELECT 100UF-M/100V		D04010108C240S		
C420	00D9630234506	C,ELECT 47UF-M/50V (Pb Free)		D040470087070S		
C421	nsp	C,CERAMIC 100PF-J/50V		D010101167160S		
C422	nsp	C,CERAMIC SL220PF-J/500V		D00022106D051S		
C423	00D9630234506	C,ELECT 47UF-M/50V (Pb Free)		D040470087070S		
C424	00D9630224503	C,ELECT 22UF-M/50V		D040220087060S		
C426	00D9609009937	C,ELECT 100UF-M/50V		D040101087060S		
C428	nsp	C,CERAMIC 470PF-K/500V		D00447127D050S		
C429	nsp	C,CERAMIC X7R2200PF-K/50V		D011222777200S		
C431,432	00D9630234302	C,ELECT 10UF-M/100V		D04010008C050S		
C434	nsp	C,CERAMIC 0.1UF-K/50V		D011104577160S		
C436	00D9630234506	C,ELECT 47UF-M/50V (Pb Free)		D040470087070S		
C437	nsp	C,CERAMIC 100PF-J/50V		D010101167160S		
C438	nsp	C,CERAMIC SL220PF-J/500V		D00022106D051S		
C439	00D9630234506	C,ELECT 47UF-M/50V (Pb Free)		D040470087070S		
C440	00D9630224503	C,ELECT 22UF-M/50V		D040220087060S		
C442	00D9609009937	C,ELECT 100UF-M/50V		D040101087060S		
C444	nsp	C,CERAMIC 470PF-K/500V		D00447127D050S		
C445	nsp	C,CERAMIC X7R2200PF-K/50V		D011222777200S		
C447,448	00D9630234302	C,ELECT 10UF-M/100V		D04010008C050S		
C450	nsp	C,CERAMIC 0.1UF-K/50V		D011104577160S		
C452	00D9630234506	C,ELECT 47UF-M/50V (Pb Free)		D040470087070S		
C453	nsp	C,CERAMIC 100PF-J/50V		D010101167160S		
C454	nsp	C,CERAMIC SL220PF-J/500V		D00022106D051S		
C455	00D9630234506	C,ELECT 47UF-M/50V (Pb Free)		D040470087070S		
C456	00D9630224503	C,ELECT 22UF-M/50V		D040220087060S		
C458	00D9609009937	C,ELECT 100UF-M/50V		D040101087060S		
C460	nsp	C,CERAMIC 470PF-K/500V		D00447127D050S		
C461	nsp	C,CERAMIC X7R2200PF-K/50V		D011222777200S		

Ref. No.	Part No.	Part Name	Remarks		Q'ty	New
C463,464	00D9630234302	C,ELECT 10UF-M/100V		D04010008C050S		
C466	nsp	C,CERAMIC 0.1UF-K/50V		D011104577160S		
C468	00D9630234506	C,ELECT 47UF-M/50V (Pb Free)		D040470087070S		
C469	nsp	C,CERAMIC 100PF-J/50V		D010101167160S		
C470	nsp	C,CERAMIC SL220PF-J/500V		D00022106D051S		
C471	00D9630234506	C,ELECT 47UF-M/50V (Pb Free)		D040470087070S		
C472	00D9630224503	C,ELECT 22UF-M/50V		D040220087060S		
C474	00D9609009937	C,ELECT 100UF-M/50V		D040101087060S		
C476	nsp	C,CERAMIC 470PF-K/500V		D00447127D050S		
C477	nsp	C,CERAMIC X7R2200PF-K/50V		D011222777200S		
C479,480	00D9630234302	C,ELECT 10UF-M/100V		D04010008C050S		
C482	nsp	C,CERAMIC 0.1UF-K/50V		D011104577160S		
C484	00D9630234506	C,ELECT 47UF-M/50V (Pb Free)		D040470087070S		
C485	nsp	C,CERAMIC 100PF-J/50V		D010101167160S		
C486	nsp	C,CERAMIC SL220PF-J/500V		D00022106D051S		
C487	00D9630234506	C,ELECT 47UF-M/50V (Pb Free)		D040470087070S		
C488	00D9630224503	C,ELECT 22UF-M/50V		D040220087060S		
C490	00D9609009937	C,ELECT 100UF-M/50V		D040101087060S		
C492	nsp	C,CERAMIC 470PF-K/500V		D00447127D050S		
C493	nsp	C,CERAMIC X7R2200PF-K/50V		D011222777200S		
C495,496	00D9630234302	C,ELECT 10UF-M/100V		D04010008C050S		
C498	nsp	C,CERAMIC 0.1UF-K/50V		D011104577160S		
C500	00D9630234506	C,ELECT 47UF-M/50V (Pb Free)		D040470087070S		
C501	nsp	C,CERAMIC 100PF-J/50V		D010101167160S		
C502	nsp	C,CERAMIC SL220PF-J/500V		D00022106D051S		
C503	00D9630234506	C,ELECT 47UF-M/50V (Pb Free)		D040470087070S		
C504	00D9630224503	C,ELECT 22UF-M/50V		D040220087060S		
C506	00D9609009937	C,ELECT 100UF-M/50V		D040101087060S		
C508	nsp	C,CERAMIC 470PF-K/500V		D00447127D050S		
C509	nsp	C,CERAMIC X7R2200PF-K/50V		D011222777200S		
C511,512	00D9630234302	C,ELECT 10UF-M/100V		D04010008C050S		
C513,514	00D9630338402	C,ELECT 330UF-M/6.3V		D040331081050S		
C515	00D9630324607	C,ELECT 47UF-M/10V (Pb Free)		D040470082060S		
OTHERS PARTS GROUP						
BKT400	nsp	BRACKET 0.8t/SCREW		4010210196100S		
CLAMP400,401	nsp	CLAMP WIRE(SOLDER)		4330000120000S		
CN404	nsp	CN.WIRE 5P		L002251052620S		*
CP401	nsp	CN.WAFER 13P STRAIGHT		L101200101310S		
CP402	nsp	CN.WAFER 5P		L102526700500S		
CP403	nsp	CN.WAFER 10P STRAIGHT		L101200101010S		
CP405	nsp	CN.WAFER 3P		L102526700300S		
G400-402	nsp	CN.WIRE 1P		L000600010050S		*
TP401-407	nsp	CN.WAFER 3P		L101200100320S		

PCB SPK ASS'Y

	Ref. No.	Part No.	Part Name	Remarks		Q'ty	New
SEMICONDUCTORS GROUP							
△	IC100	963239010480S	IC PC123X2YFZ (DIP4P SHARP)		K614123000010S		
△	IC102	231010091708S	IC TOP258MG		G200258000010S		*
	IC116	212050010508S	IC KIA2431AP		J126243118010S		
	Q1-5	00D9630120704	TR KRA102S(PB)		J520010200210S		
	Q8-12	00D9630120801	TR 2SC KRC102S (NB)		J522010200210S		
	D1-5	00D9630355401	D,SWITCHING KDS4148U		K005041480030S		
	D8	00D2760401905	D,SWITCHING 1SS133T		K000013300520S		
	D9,10	963209011740S	D,RECTIFIER BRIDGE D3SB60-5000		K047036040030S		
	D100-102	00D9630328409	D,SWITCHING 1N4007		K000400700010S		
	D103	203050018706S	D,SCHOTTKY D25SC6M 60V 25A		K120256000010S		
	D104-106	00D9630328409	D,SWITCHING 1N4007		K000400700010S		
	D108	963209010430S	D,FAST RECOVERY AP01C-V1 52RE-AX		K050000015000S		
	D109,110	00D9630328409	D,SWITCHING 1N4007		K000400700010S		
	D112	00D2760401905	D,SWITCHING 1SS133T		K000013300520S		
	ZD100	963202010440S	D,ZENER MTZJ22B		K06022R044520S		
	ZD101	00D2760762958	D,ZENER MTZJ39B	1911E3,791E3	K06039R044520S		
	ZD102	963202010440S	D,ZENER MTZJ22B		K06022R044520S		
	ZD103	00D2760762958	D,ZENER MTZJ39B	1911E3,791E3	K06039R044520S		
	ZD104	963202010440S	D,ZENER MTZJ22B		K06022R044520S		
	ZD105	00D2760762958	D,ZENER MTZJ39B	1911E3,791E3	K06039R044520S		
	ZD106,107	963202010440S	D,ZENER MTZJ22B		K06022R044520S		
	ZD108,109	00D2760762958	D,ZENER MTZJ39B	1911E3,791E3	K06039R044520S		
	ZD110	963202010440S	D,ZENER MTZJ22B	1911E3,791BKE3	K06022R044520S		
	ZD110	00D2760762958	D,ZENER MTZJ39B	1911E2,1911E1C,791EA	K06039R044520S		
	ZD111	00D2760762958	D,ZENER MTZJ39B	1911E2, 1911E1C,791EA	K06039R044520S		
	ZD112	963202010440S	D,ZENER MTZJ22B		K06022R044520S		
	ZD113	00D2760762958	D,ZENER MTZJ39B	1911E2,1911E1C,791EA	K06039R044520S		
	ZD114	00D9600095607	D,ZENER MTZJ5.6B		K06005R644520S		
	ZD115	00D2760762958	D,ZENER MTZJ39B		K06039R044520S		
	ZD116	00D2760762958	D,ZENER MTZJ39B	1911E2,1911E1C,791EA	K06039R044520S		
	ZD117,118	963202010440S	D,ZENER MTZJ22B		K06022R044520S		
	ZD119	00D2760762958	D,ZENER MTZJ39B	1911E2,1911E1C,791EA	K06039R044520S		
	DZ1	00D9600095801	D,ZENER MTZJ6.8B		K06006R844520S		
	TR100-102	00D9630255802	TR 2SC KTC3199Y		J5023199Y0010S		
RESISTORS GROUP							
	R5-18	963125010100S	R,METAL FILM 10-J 2W		C060010066050S		
	R28-33	00D9630310404	R,METAL FILM 2.2K-J,1W		C060022265050S		
	R34	nsp	R,METAL FILM 10K-J,1/4W		C060103063050S		
	R35,36	nsp	R,METAL FILM 47K-J,1/4W		C060047363050S		
	R37,38	963125010110S	R,METAL FILM 470-J,2W		C060047166060S		
CAPACITORS GROUP							
	C1	nsp	C,FILM MI-0.047UF-J/50V		D020473167050S		

Ref. No.	Part No.	Part Name	Remarks	Q'ty	New
C2	nsp	C,CERAMIC 2200PF-K/50V		D011222777160S	
C3,4	nsp	C,FILM MI-0.047UF-J/50V		D020473167050S	
C5	nsp	C,CERAMIC 2200PF-K/50V		D011222777160S	
C6	nsp	C,FILM MI-0.047UF-J/50V		D020473167050S	
C7	nsp	C,CERAMIC 2200PF-K/50V		D011222777160S	
C8,9	nsp	C,FILM MI-0.047UF-J/50V		D020473167050S	
C10	nsp	C,CERAMIC 2200PF-K/50V		D011222777160S	
C11,12	nsp	C,FILM MI-0.047UF-J/50V		D020473167050S	
C13	nsp	C,CERAMIC 2200PF-K/50V		D011222777160S	
C14	nsp	C,FILM MI-0.047UF-J/50V		D020473167050S	
C15	nsp	C,CERAMIC 2200PF-K/50V		D011222777160S	
C16,17	nsp	C,FILM MI-0.047UF-J/50V		D020473167050S	
C18	nsp	C,CERAMIC 2200PF-K/50V		D011222777160S	
C19	nsp	C,FILM MI-0.047UF-J/50V		D020473167050S	
C22	nsp	C,FILM MI-0.047UF-J/50V		D020473167050S	
C25	nsp	C,FILM MI-0.047UF-J/50V		D020473167050S	
C27	nsp	C,CERAMIC 1000PF-K/50V		D011102777160S	
C30	nsp	C,CERAMIC 1000PF-K/50V		D011102777160S	
C33	nsp	C,CERAMIC 1000PF-K/50V		D011102777160S	
C36	nsp	C,CERAMIC 1000PF-K/50V		D011102777160S	
C39	nsp	C,CERAMIC 1000PF-K/50V		D011102777160S	
C42,45	nsp	C,CERAMIC 1000PF-K/50V		D011102777160S	
C53	00D9609009937	C,ELECT 100UF-M/50V		D040101087060S	
C54	nsp	C,FILM 0.1UF-K/250V		D02010407H080S	
C55	963134010180S	C,ELECT 12000UF-M/71V		D040123089550S	
C57	00D9630234205	C,ELECT 10UF-M/50V		D040100087070S	
C58	963134010180S	C,ELECT 12000UF-M/71V		D040123089550S	
C60	00D9630244606	C,ELECT 0.1UF-M/50V (Pb Free)		D040R10087080S	
C61	nsp	C,FILM 0.1UF-K/250V		D02010407H080S	
C63	nsp	C,CERAMIC 1000PF-K/50V		D011102777160S	
△ C100	963132010140S	C,CERAMIC ECQU2A104ML 0.1UF		D00810408H000S	
C102	963134010200S	C,ELECT 100UF-M/400V		D04110108K000S	
C103	963132010120S	C,CERAMIC DEHR33A102KB2B		D00810207Q010S	
△ C104,105	963134011730S	C,CERAMIC DE1B3KX471KB4L01 AC250V		D00847127H010S	
C106-108	963134010220S	C,ELECT5600UF-M/6.3V		D041562081001S	
C110	nsp	C,CERAMIC 0.1UF-K/25V		D011104774161S	
C111	nsp	C,CERAMIC 4.7UF-K/6.3V		D011475571160S	
C112	963134010190S	C,ELECT 10UF-M/50V		D041100087050S	
C113	nsp	C,CERAMIC 0.1UF-K/25V		D011104774161S	
△ C115	963132011930S	C,CERAMIC DE1E3KX222MB4L01 AC250V		D00822248H010S	
C116	nsp	C,CERAMIC 0.1UF-K/25V		D011104774161S	
△ C117	963132011940S	C,CERAMIC DE2F3KY103MB3BM02 AC250V		D008103589010S	
C118	nsp	C,CERAMIC 0.1UF-K/25V		D011104774161S	
C119	963134010210S	C,ELECT 47UF-M/25V		D041470084050S	
C120-123	nsp	C,CERAMIC 0.1UF-K/25V		D011104774161S	
△ C131, 133	963132011940S	C,CERAMIC DE2F3KY103MB3BM02 AC250V		D008103589010S	
OTHERS PARTS GROUP					
BKT1-3	nsp	BRACKET t1.0+Sn plating /PCB MTG		4010214876000S	
BKT100	nsp	BRACKET 0.8t/SCREW		4010210196100S	
BKT101	nsp	BRACKET SCREW		4010210196000S	

	Ref. No.	Part No.	Part Name	Remarks		Q'ty	New
	CLAMP3	nsp	CLAMP WIRE(SOLDER)		4330000120000S		
	CN1	nsp	CN,WIRE 230MM/5P		L000231052050S		
	CN2	nsp	CN,WIRE 670MM/2P		L000671020010S		
	CN3	nsp	CN,WIRE 2MM 170MM/10P		L002171102620S		
	CP1	nsp	CN.WAFER 3CKT		L108353280360S		
	CP12	nsp	CN.FPC 1.25MM 19P		L131019100010S		
	CP22	nsp	CN.WAFER 5P		L101100040510S		
	CX100	nsp	CN.WAFER 7.92MM	1911E3, 1911E1C, 791E3	L108202000220S		
	CX102	nsp	CN.WAFER 7.92MM		L108353280290S		
	CX104	nsp	CN.WAFER 5P		L101100030510S		
	CX105	nsp	CN,WIRE 370MM/5P		L000371050010S		
	△ F100	963652010510S	FUSE T2A/250V	1911E3,791E3	N751502001160S		*
	△ F100	963652010500S	FUSE T1.6A/250V	1911E2,1911E1C,791EA	N751501601160S		*
	△ F101	963652010520S	FUSE T6.3A/250V	1911E3,791E3	N751506301160S		*
	△ F101	963652010910S	FUSE T3.15A/250V	1911E2, 1911E1C, 791EA	N751503151160S		
	JACK1	963643010360S	6P JB-602A-02		G613602A0200YS		
	JACK2	963646001690S	8P SPEAKER TERMINAL		G614108V1010MS		
	△ JK100	963641011240S	SOCKET,POWER AC	1911E2,791EA	G4300152P0001S		
	L1-7	nsp	COIL INDUCTOR 0.5UH		D330R50000000S		
	△ L100	963111010230S	COIL LINE FILTER LF-4ZB-E273H 27mH		D320402730020S		
	△ RL101	963682010370S	RELAY HL31-1AT-5H 5V 1A		G680050102020S		*
	RLY1	00D9630218409	RELAY BC3-12 24V 2A		G680240202030S		
	RLY2-5	963682002440S	RELAY 12V 5A SPK		G680120502050S		
	△ T100	963102010240S	TRANS,SWITCHING ST-4430A		E060044300010S		*
	WIRE5	nsp	CN,WIRE 900MM/2P		L000901020010S		
		nsp	HOLDER,FUSE CLIP	F100_1	G645000050010S		
		nsp	HOLDER,FUSE CLIP	F100_2	G645000050010S		
		nsp	HOLDER,FUSE CLIP	F101_1	G645000050010S		
		nsp	HOLDER,FUSE CLIP	F101_2	G645000050010S		

PCB REG_CNT ASS'Y

Ref. No.	Part No.	Part Name	Remarks	Q'ty	New
SEMICONDUCTORS GROUP					
IC1	963239001880S	IC AZ4580M	1911E3	J121458000020S	
IC103	00D2630553006	IC NJM7805FA		J126780500130S	
IC104	00D2630554005	IC NJM7905FA		J126790500020S	
IC105	00D2630553006	IC NJM7805FA		J126780500130S	
IC106	00D2630810008	IC NJM7808FA		J126780800030S	
IC107	00D2630503001	IC NJM7908FA		J126790800020S	
IC108	963239003420S	IC NJM2388F05	791E3	J126238800050S	
IC108	963239010770S	IC NJM2388F09	1911E2,1911E1C,791EA	J126238800090S	
IC109	231310009508S	IC PQ033DNA1ZPH	1911E3	J126033010010S	
D114	00D9630236504	D,SWITCHING RB721Q-40		K120072140010S	
D115,116	00D2760401905	D,SWITCHING 1SS133T		K000013300520S	
D117,118	00D9630236504	D,SWITCHING RB721Q-40		K120072140010S	
D119-121	00D2760401905	D,SWITCHING 1SS133T		K000013300520S	
D122	00D9630236504	D,SWITCHING RB721Q-40		K120072140010S	
D123	00D2760401905	D,SWITCHING 1SS133T	1911E2,1911E1C,791E3,791EA	K000013300520S	
D124,125	00D9630328409	D,SWITCHING 1N4007	1911E2,1911E1C,791EA	K000400700010S	
D127-134	00D9630328409	D,SWITCHING 1N4007		K000400700010S	
D137-145	00D9630328409	D,SWITCHING 1N4007		K000400700010S	
ZD117,118	00D9600096004	D,ZENER MTZJ33B		K06033R044520S	
CAPACITORS GROUP					
C61	nsp	C,CERAMIC 33PF-J/50V	1911E3	D010330167160S	
C62,63	00D9630234205	C,ELECT 10UF-M/50V	1911E3	D040100087070S	
C64	nsp	C,CERAMIC 33PF-J/50V	1911E3	D010330167160S	
C65	nsp	C,CERAMIC 0.1UF-K/50V	1911E3	D011104577160S	
C66	nsp	C,CERAMIC 1UF-K/16V	1911E3	D011105173161S	
C67	nsp	C,CERAMIC 33PF-J/50V	1911E3	D010330167160S	
C68,69,70	00D9630234205	C,ELECT 10UF-M/50V	1911E3	D040100087070S	
C71	nsp	C,CERAMIC 0.1UF-K/50V	1911E3	D011104777200S	
C72	nsp	C,CERAMIC 33PF-J/50V	1911E3	D010330167160S	
C73	nsp	C,CERAMIC 1UF-K/16V	1911E3	D011105173161S	
C74	nsp	C,CERAMIC 0.1UF-K/50V	1911E3	D011104577160S	
C75	00D9630234205	C,ELECT 10UF-M/50V	1911E3	D040100087070S	
C76,77,78	nsp	C,CERAMIC 100PF-J/50V	1911E3	D010101167160S	
C79	nsp	C,CERAMIC 0.1UF-K/50V	1911E3	D011104577160S	
C80,81	00D9630234205	C,ELECT 10UF-M/50V	1911E3	D040100087070S	
C126	00D9630217002	C,ELECT 3300UF-M/16V	1911E3,1911E2,1911E1C,791EA	D040332083010S	
C126	963134011290S	C,ELECT 4700UF-M/16V	791E3	D040472083020S	
C127,128	00D9630234205	C,ELECT 10UF-M/50V		D040100087070S	
C129	00D9630217002	C,ELECT 3300UF-M/16V		D040332083010S	
C130	00D9630333203	C,ELECT 100UF-M/16V		D040101083090S	
C131	00D9630234205	C,ELECT 10UF-M/50V		D040100087070S	
C132	00D9630333203	C,ELECT 100UF-M/16V		D040101083090S	
C133	90M-OA000500R	C,ELECT 4700UF-M/25V(MHA)		D040472084240S	
C134	00D9630333203	C,ELECT 100UF-M/16V		D040101083090S	
C135	90M-OA000500R	C,ELECT 4700UF-M/25V(MHA)		D040472084240S	
C136	00D9630333203	C,ELECT 100UF-M/16V	1911E2,1911E1C,791E3,791EA	D040101083090S	

	Ref. No.	Part No.	Part Name	Remarks		Q'ty	New
	C137	00D9630234205	C,ELECT 10UF-M/50V	1911E2,1911E1C,791E3,791EA	D040100087070S		
	C139,140	963134011280S	C,ELECT 470UF-M/25V	1911E2,1911E1C,791EA	D040471084060S		
	C142-144	nsp	C,FILM 0.1UF-J/50V		D020104167050S		
	C146-148	nsp	C,FILM 0.1UF-J/50V		D020104167050S		
OTHERS PARTS GROUP							
	BKT101	nsp	BRACKET 0.8t/SCREW		4010210196100S		
	CLAMP101	nsp	CLAMP WIRE(SOLDER)		4330000120000S		
	CN10	nsp	CN,WAFER 11P		L109012521110S		*
	CN11	nsp	CN,WAFER 25P		L109012522510S		*
	CN13	nsp	CN,WIRE 2MM 120MM/13P		L002121130010S		*
	CN15	nsp	CN,WIRE 2MM 120MM/4P		L002121040110S		*
	CN100	nsp	CN,WAFER 13P		L109012521310S		*
	CN101	nsp	CN,WAFER11P		L109012521110S		*
	CN102	nsp	CN,WAFER 17P		L109012521710S		*
	CN103	nsp	CN,WAFER 19P		L109012521910S		*
	CN104	nsp	CN,WAFER 27P		L109012522710S		*
	CN105	nsp	CN,WAFER 17P		L109012521710S		*
	CP3	nsp	CN,WAFER 11P		L109012511110S		*
	CP4	nsp	CN,WAFER 25P		L109012512510S		*
	CP13A	nsp	CN.WAFER 13P		L101200101320S		
	CP14	nsp	CN.WAFER 4P		L101200100420S		
	CP100	nsp	CN,WAFER 13P		L109012511310S		*
	CP101	nsp	CN,WAFER 11P		L109012511110S		*
	CP102	nsp	CN.WAFER 4P		L102526700400S		
	CP104	nsp	CN.WAFER 3P		L102526700300S		
	CP105	nsp	CN,WAFER 19P		L109012511910S		*
	CP106	nsp	CN,WAFER 17P		L109012511710S		*
	CP108	nsp	CN,WAFER 19P		L109012511910S		*
	CP109	nsp	CN,WAFER17P		L109012511710S		*
	CP110	nsp	CN.WAFER33P		L109012513310S		*
	CP801	nsp	CN.FPC 1.25-2-13P	1911E3	L131125021310S		
	△ F104	963652010500S	FUSE T1.6A/250V	1911E2,1911E1C,791EA	N751501601160S		*
	△ F105-108	963652010500S	FUSE T1.6A/250V		N751501601160S		*
	F104A, F104B	nsp	HOLDER,FUSE CLIP	1911E2,1911E1C,791EA	G645000050010S		
	F105A-108A	nsp	HOLDER,FUSE CLIP		G645000050010S		
	F105B-108B	nsp	HOLDER,FUSE CLIP		G645000050010S		
		nsp	BRACKET SCREW		4010210196000S		

PCB FRONT ASS'Y

	Ref. No.	Part No.	Part Name	Remarks		Q'ty	New
SEMICONDUCTORS GROUP							
	IC100	963239001880S	IC AZ4580M		J121458000020S		
△	IC101	00D9600195808	IC ICP-N15		J120001500030S		
	IC102	963239001880S	IC AZ4580M		J121458000020S		
	Q100,101	00D9630121509	TR KTC3875S		J522038750210S		
	Q102	00D9600133103	TR KSA916Y		J5000916Y0050S		
	Q106	00D9600285006	TR KRC104S (ND)		J522104S00210S		
	Q107,108	00D2710305909	SEMI KTA1504S		J520015040150S		
	Q109	00D9630121402	TR KRA104S		J520010400210S		
	Q111-112	00D9630120801	TR 2SC KRC102S (NB)		J522010200210S		
	D100,101	00D9630328409	D,SWITCHING 1N4007		K000400700010S		
	D102,103	00D9630355401	D,SWITCHING KDS4148U		K005041480030S		
	D111-114	00D9630355401	D,SWITCHING KDS4148U		K005041480030S		
	D115-117	963209003510S	D,ESD CDS3C05HDMI1		K067030500010S		
	D118-121	00D9630355401	D,SWITCHING KDS4148U		K005041480030S		
	ZD100	00D9600095500	D,ZENER MTZJ5.1B		K06005R144520S		
	ZD101	00D9600095801	D,ZENER MTZJ6.8B		K06006R844520S		
	ZD102	00D9630046202	D,ZENER MTZJ18B		K06018R044520S		
	ZD103	00D9630219903	D,ZENER MTZJ16B		K06016R044520S		
	ZD104,105	00D9600095500	D,ZENER MTZJ5.1B		K06005R144520S		
	LED101	963262010460S	LED SIR-341ST3F 3PI	1911E3	K505341300010S		
	LED103	00D9630366108	LED BL-BEG204-L 5PI		K500052004010S		
RESISTORS GROUP							
	R127	00D9639006272	R,FIXED RSD-R1-1WJ-4.7		N113135647920S		
CAPACITORS GROUP							
	C100	00D9630234205	C,ELECT 10UF-M/50V		D040100087070S		
	C101	nsp	C,FILM 0.1UF-J/100V		D02010406C060S		
	C103	00D9630293602	C,ELECT 1UF-M/50V (Pb Free)		D040010087150S		
	C104	nsp	C,CERAMIC 0.047UF-Z/50V		D011473597160S		
	C105	nsp	C,CERAMIC 0.1UF-K/50V		D011104577160S		
	C106	nsp	C,CERAMIC 100PF-J/50V		D010101167160S		
	C107	nsp	C,CERAMIC COG82PF-J/50V		D010820167160S		
	C108	nsp	C,FILM 0.047UF-J/100V		D02047306C060S		
	C109	nsp	C,FILM 0.1UF-J/100V		D02010406C060S		
	C110	nsp	C,CERAMIC 0.047UF-Z/50V		D011473597160S		
	C111	nsp	C,CERAMIC 1UF-Z/50V		D011105597160S		
	C112	00D9630234205	C,ELECT 10UF-M/50V		D040100087070S		
	C113	90M-OF100250R	C,FILM 0.1UF-K/250V		D02010407H080S		
	C114	nsp	C,CERAMIC 330PF-J/50V		D010331167160S		
	C115	nsp	C,CERAMIC0.047UF-K/25V		D011473774161S		
	C116	00D9630293602	C,ELECT 1UF-M/50V (Pb Free)		D040010087150S		
	C117	00D9630157900	C,ELECT 470UF-M/63V		D040471088000S		
	C118	00D9630293602	C,ELECT 1UF-M/50V (Pb Free)		D040010087150S		

	Ref. No.	Part No.	Part Name	Remarks		Q'ty	New
	C119	nsp	C,FILM 0.1UF-K/250V		D02010407H080S		
	C120	nsp	C,CERAMIC 330PF-J/50V		D010331167160S		
	C121	nsp	C,CERAMIC 0.1UF-K/50V		D011104577160S		
	C122	00D9630234205	C,ELECT 10UF-M/50V		D040100087070S		
	C123	00D9630293602	C,ELECT 1UF-M/50V (Pb Free)		D040010087150S		
	C124-126	nsp	C,CERAMIC 100PF-J/50V		D010101167160S		
	C127	nsp	C,CERAMIC0.047UF-K/25V		D011473774161S		
	C129	00D9630293602	C,ELECT 1UF-M/50V (Pb Free)		D040010087150S		
	C130	00D9630234205	C,ELECT 10UF-M/50V		D040100087070S		
	C131	nsp	C,CERAMIC 0.1UF-K/50V		D011104577160S		
	C132	00D9630293602	C,ELECT 1UF-M/50V (Pb Free)		D040010087150S		
	C133	nsp	C,CERAMIC 0.047UF-Z/50V		D011473597160S		
	C134	00D9630293602	C,ELECT 1UF-M/50V (Pb Free)		D040010087150S		
	C137	nsp	C,CERAMIC 0.047UF-Z/50V		D011473597160S		
	C139	nsp	C,CERAMIC 0.01UF-K/50V		D011103777162S		
	C142	nsp	C,FILM 0.047UF-J/100V		D02047306C060S		
	C143,144	00D9630293602	C,ELECT 1UF-M/50V (Pb Free)		D040010087150S		
	C145	nsp	C,FILM 0.047UF-J/100V		D02047306C060S		
	C146	nsp	C,CERAMIC 0.1UF-K/50V		D011104577160S		
	C147	00D9630234205	C,ELECT 10UF-M/50V		D040100087070S		
	C148,149	nsp	C,CERAMIC 0.01UF-K/50V		D011103777162S		
	C150	nsp	C,CERAMIC 0.047UF-Z/50V		D011473597160S		
	C151	nsp	C,ELECT 47UF-M/16V		D040470083080S		
	C152	nsp	C,CERAMIC 0.047UF-Z/50V		D011473597160S		
	C153	nsp	C,FILM ST-0.01UF-J/100V		D02010306C060S		
	C154	nsp	C,CERAMIC 0.1UF-K/50V		D011104577160S		
	C155	nsp	C,FILM ST-0.01UF-J/100V		D02010306C060S		
	C156,157	nsp	C,CERAMIC 1000PF-K/50V		D011102777160S		
	C158	nsp	C,CERAMIC 0.01UF-K/50V		D011103777162S		
	C159	nsp	C,CERAMIC 0.047UF-Z/50V		D011473597160S		
	C160	nsp	C,CERAMIC 0.01UF-K/50V		D011103777162S		
	C161	nsp	C,CERAMIC 0.047UF-Z/50V		D011473597160S		
	C163	nsp	C,CERAMIC 0.1UF-K/50V		D011104577160S		
	C164	nsp	C,ELECT 220UF-M/6.3V		D040221081070S		
	C165	nsp	C,CERAMIC 0.01UF-K/50V		D011103777162S		
	C166	00D9630293709	C,ELECT 100UF-M/10V		D040101082070S		
	C168,169	nsp	C,CERAMIC 0.01UF-K/50V		D011103777160S		
OTHERS PARTS GROUP							
	BD100-104	nsp	R,THICK 0-J,1/16W		C2000006M160S		
	BD105	nsp	COIL,BEAD CBW160808U121T		D340160811210S		
	BD106-109	nsp	R,THICK 0-J,1/16W		C2000006M160S		
	BD110	nsp	COIL,BEAD BLM21PG221SN1		D340201212210S		
	BD111-112	nsp	COIL,BEAD BLM18AG121SN1D		D340160831211S		
	CB100,101	nsp	R,THICK 0-J,1/16W		C2000006M160S		
	CLAMP111	nsp	CLAMP WIRE(SOLDER)		4330000120000S		
	CLAMP114	nsp	CLAMP WIRE(SOLDER)		4330000120000S		
	CLAMP116	nsp	CLAMP WIRE(SOLDER)		4330000120000S		
	CN100	nsp	CN,WIRE 2MM 130MM/5P		L002131050010S		*

Ref. No.	Part No.	Part Name	Remarks	Q'ty	New
CN102	nsp	CN,WIRE 2MM 450MM/5P		L002451050120S	*
CP100	nsp	CN.WAFER 5P		L101200100510S	
CP100_1	nsp	5268-07A 7P ANGLE		L102526800700S	
CP102	nsp	CN.WAFER 2.0MM 8P		L101100030810S	
CP103,104	nsp	CN.WAFER 8P		L101100040810S	
CP105	nsp	CN.WAFER 2.0MM 8P		L101100030810S	
G101	nsp	RING,TER WIRE 100MM/1P		8410101010240S	
JACK100	00D9630367802	JACK,D3.5 EARPHONE		G401PJ354H40YS	
JACK101	963649010300S	CN,PLUG DIP4P BK USBAS-00401B014-G		G480040101410S	*
JACK102	00D9630146403	TER,RCA 3PIN		G606308HG110YS	
JK100	00D9630294708	JACK,D6.5 PHONE		G402PJ612AG0YS	
L100	nsp	COIL INDUCTOR 100UH		D330101001020S	
RMC100	963262010290S	MODULE,REMOCON R34FS9A		E940349003810S	
SW100-123	00D9630095305	SW,TACT SKHV10910D01		G180040500010S	
VEC100,101	00D9630387408	SW,ENCODER EC16B24SO		G121162400070S	
U1	nsp	CN.FPC 1.0MM 1.0-11S-40PW 40P		L130100114050S	*
U100	963172010470S	DISPLAY,FLT 18-ST-13GINK		K530180130010S	
JP209-213	nsp	R,CHIP 0-J,1/8W		C200000061300S	
	nsp	HOLDER FLT		4320200026000S	

PCB AUDIO_VIDEO ASS'Y

Ref. No.	Part No.	Part Name	Remarks		Q'ty	New
SEMICONDUCTORS GROUP						
IC801	235810045600S	IC R2A15220FP		J084152200010S		*
IC804	00D2623446900	IC TC4052BFT		J040405201010S		
IC805	232810005504S	IC BD7628F-E2		J127762800010S		
IC806	963239010400S	IC MM74HC4053MTC		J040744053050S		
IC807,808	232810005504S	IC BD7628F-E2		J127762800010S		
IC809	00D2623445901	IC TC4051BFT		J040405101010S		
IC810	00D9630116307	IC LC74781-9013-E		J170747810010S		
IC811	963239003470S	IC NJM2586AM		J171258600010S		
Q815	00D9630044301	TR KTC2875B(MB)	1911E2,1911E1C,791EA	J5222875B0010S		
Q816,817	00D9630120704	TR KRA102S(PB)	1911BKE3	J520010200210S		
Q815	00D9630044301	TR KTC2875B(MB)	1911E2,1911E1C,791EA	J5222875B0010S		
Q821	00D9630044301	TR KTC2875B(MB)		J5222875B0010S		
Q822,823	00D9630120704	TR KRA102S(PB)		J520010200210S		
Q824-825	963219010760S	TR KRC231(NW)		J5220231M0010S		
Q826	00D9630120801	TR 2SC KRC102S (NB)		J522010200210S		
Q827	963219010740S	TR KRA111S		J520011100210S		
Q828	00D9630120801	TR 2SC KRC102S (NB)		J522010200210S		
Q829,830	00D9630120801	TR 2SC KRC102S (NB)		J522010200210S		
Q831	00D2710305909	SEMI KTA1504S		J520015040150S		
Q832,833	00D9630121509	TR KTC3875S		J522038750210S		
Q834	00D2710305909	SEMI KTA1504S		J520015040150S		
Q838	00D9630120801	TR 2SC KRC102S (NB)		J522010200210S		
Q839	00D2710305909	SEMI KTA1504S		J520015040150S		
Q840	00D9630121606	TR KRC107S (NH)		J522107S00210S		
Q841	00D9630120801	TR 2SC KRC102S (NB)	1911E3	J522010200210S		
Q842	00D9630120801	TR 2SC KRC102S (NB)		J522010200210S		
D800,801	00D9630328409	D,SWITCHING 1N4007		K000400700010S		
D826	00D9630328409	D,SWITCHING 1N4007		K000400700010S		
D828,829	00D9630328409	D,SWITCHING 1N4007		K000400700010S		
D833,834	963209003510S	D,ESD CDS3C05HDMI1		K067030500010S		
D837	963209003510S	D,ESD CDS3C05HDMI1		K067030500010S		
D838-843	00D9630355401	D,SWITCHING KDS4148U		K005041480030S		
ZD800	00D2760760905	D,ZENER MTZJ3.6B-0.5W/5MA		K06003R644520S		
CAPACITORS GROUP						
C800-807	00D9630234205	C,ELECT 10UF-M/50V		D040100087070S		
C808	00D9630333203	C,ELECT 100UF-M/16V		D040101083090S		
C809,810	00D9630234205	C,ELECT 10UF-M/50V		D040100087070S		
C811	00D9630333203	C,ELECT 100UF-M/16V		D040101083090S		
C812,813	nsp	C,CERAMIC 330PF-J/50V		D010331167160S		
C826	nsp	C,CERAMIC 330PF-J/50V		D010331167160S		
C828	00D9630293709	C,ELECT 100UF-M/10V		D040101082070S		
C829	nsp	C,CERAMIC 330PF-J/50V		D010331167160S		
C830	00D9630293709	C,ELECT 100UF-M/10V		D040101082070S		
C831	00D9630234205	C,ELECT 10UF-M/50V		D040100087070S		
C832	00D9630293709	C,ELECT 100UF-M/10V		D040101082070S		
C833	00D9630234205	C,ELECT 10UF-M/50V		D040100087070S		
C834	nsp	C,CERAMIC 330PF-J/50V		D010331167160S		
C835,836	00D9630293709	C,ELECT 100UF-M/10V		D040101082070S		

Ref. No.	Part No.	Part Name	Remarks		Q'ty	New
C837	nsp	C,CERAMIC 330PF-J/50V			D010331167160S	
C838,839	00D9630293709	C,ELECT 100UF-M/10V			D040101082070S	
C840	00D9630234205	C,ELECT 10UF-M/50V			D040100087070S	
C842	nsp	C,CERAMIC 330PF-J/50V			D010331167160S	
C844	00D9630234205	C,ELECT 10UF-M/50V			D040100087070S	
C845	00D9630333203	C,ELECT 100UF-M/16V			D040101083090S	
C846	00D9630293709	C,ELECT 100UF-M/10V			D040101082070S	
C847	nsp	C,CERAMIC 330PF-J/50V			D010331167160S	
C852,853	00D9630224503	C,ELECT 22UF-M/50V	1911E3		D040220087060S	
C854	nsp	C,CERAMIC 330PF-J/50V			D010331167160S	
C855	nsp	C,CERAMIC 330PF-J/50V	1911E3		D010331167160S	
C856	nsp	C,CERAMIC 330PF-J/50V			D010331167160S	
C857	nsp	C,CERAMIC 330PF-J/50V	1911E3		D010331167160S	
C858	00D9609010023	C,ELECT 0.47UF-M/50V	1911E3		D040R47087050S	
C859,860	00D9630224503	C,ELECT 22UF-M/50V	1911E3		D040220087060S	
C862-864	nsp	C,CERAMIC 0.01UF-K/50V			D010103777160S	
C867	nsp	C,CERAMIC 0.01UF-K/50V			D010103777160S	
C868,869	00D9630224503	C,ELECT 22UF-M/50V			D040220087060S	
C870	nsp	C,CERAMIC 100PF-J/50V			D010101167160S	
C871	00D9609010023	C,ELECT 0.47UF-M/50V			D040R47087050S	
C872	00D9630234205	C,ELECT 10UF-M/50V			D040100087070S	
C875	00D9630234205	C,ELECT 10UF-M/50V			D040100087070S	
C876-880	nsp	C,CERAMIC 100PF-J/50V	791E3		D010101167160S	
C881	nsp	C,CERAMIC 0.1UF-K/50V	791E3		D011104577160S	
C882	nsp	C,CERAMIC 100PF-J/50V	1911E2, 1911E1C,791EA		D010101167160S	
C883	00D9630234205	C,ELECT 10UF-M/50V			D040100087070S	
C884	nsp	C,CERAMIC 100PF-J/50V	1911E2, 1911E1C,791EA		D010101167160S	
C885	nsp	C,CERAMIC 0.047UF-Z/50V			D011473597160S	
C886	nsp	C,CERAMIC 100PF-J/50V	1911E2, 1911E1C,791EA		D010101167160S	
C887	nsp	C,CERAMIC 33PF-J/50V	1911E2, 1911E1C,791EA		D010330167160S	
C888-889	nsp	C,CERAMIC 100PF-J/50V	1911E2, 1911E1C,791EA		D010101167160S	
C903,904	00D9639005862	C,ELECT 47UF-M/16V			D040470083080S	
C905,906	nsp	C,CERAMIC 0.01UF-K/50V			D010103777160S	
C907	nsp	C,CERAMIC 0.047UF-Z/50V			D011473597160S	
C909	nsp	C,CERAMIC 0.047UF-Z/50V			D011473597160S	
C910	nsp	C,CERAMIC 0.1UF-K/50V			D011104577160S	
C911	00D9630293602	C,ELECT 1UF-M/50V (Pb Free)			D040010087150S	
C912	nsp	C,CERAMIC 0.01UF-K/50V			D010103777160S	
C913	nsp	C,CERAMIC 0.047UF-Z/50V			D011473597160S	
C914,915	00D9639005862	C,ELECT 47UF-M/16V			D040470083080S	
C916,917	nsp	C,CERAMIC 0.01UF-K/50V			D010103777160S	
C918	00D9630293709	C,ELECT 100UF-M/10V			D040101082070S	
C919	nsp	C,CERAMIC 0.01UF-K/50V			D010103777160S	
C920	00D9630293709	C,ELECT 100UF-M/10V			D040101082070S	
C921	00D9630333203	C,ELECT 100UF-M/16V			D040101083090S	
C922	00D9630234205	C,ELECT 10UF-M/50V			D040100087070S	
C923	00D9630224503	C,ELECT 22UF-M/50V			D040220087060S	
C924	00D9630333203	C,ELECT 100UF-M/16V			D040101083090S	
C925	nsp	C,CERAMIC 0.01UF-K/50V			D010103777160S	
C926	00D9630293709	C,ELECT 100UF-M/10V			D040101082070S	
C927	nsp	C,CERAMIC HIK X7R1200PF-K/50V			D011122777160S	
C928	00D9630293602	C,ELECT 1UF-M/50V (Pb Free)			D040010087150S	
C929	nsp	C,CERAMIC 0.01UF-K/50V			D010103777160S	
C930	00D9630224503	C,ELECT 22UF-M/50V			D040220087060S	
C931,932	nsp	C,CERAMIC 0.01UF-K/50V			D010103777160S	

Ref. No.	Part No.	Part Name	Remarks		Q'ty	New
C933	00D9630293602	C,ELECT 1UF-M/50V (Pb Free)		D040010087150S		
C934	00D9630293709	C,ELECT 100UF-M/10V		D040101082070S		
C935,936	nsp	C,CERAMIC 0.01UF-K/50V		D010103777160S		
C937	00D9639005862	C,ELECT 47UF-M/16V		D040470083080S		
C938,939	nsp	C,CERAMIC COG24PF-J/50V		D010240167160S		
C940	nsp	C,CERAMIC 0.022UF-Z/50V		D011223597160S		
C941	nsp	C,CERAMIC 0.01UF-K/50V		D010103777160S		
C942,943	nsp	C,CERAMIC 20PF-J/50V		D010200167160S		
C944	00D9630293709	C,ELECT 100UF-M/10V		D040101082070S		
C945	nsp	C,CERAMIC COG68PF-J/50V		D010680167160S		
C949,950	nsp	C,CERAMIC 0.1UF-K/50V		D011104577160S		
C951,952	nsp	C,CERAMIC COG68PF-J/50V		D010680167160S		
C956,957	nsp	C,CERAMIC 0.1UF-K/50V		D011104577160S		
C958	00D9630293709	C,ELECT 100UF-M/10V		D040101082070S		
C960	nsp	C,CERAMIC 0.047UF-Z/50V		D011473597160S		
C963	nsp	C,CERAMIC 0.047UF-Z/50V		D011473597160S		
C964	nsp	C,CERAMIC 0.01UF-K/50V		D010103777160S		
C965	00D9630293602	C,ELECT 1UF-M/50V (Pb Free)		D040010087150S		
C966	nsp	C,CERAMIC 0.047UF-Z/50V		D011473597160S		
C967	nsp	C,CERAMIC 220PF-J/50V		D010221167160S		
C968,971,974	00D9630293602	C,ELECT 1UF-M/50V (Pb Free)		D040010087150S		
C1110,1111	nsp	C,FILM 0.0047UF	1911E2	D02047206C060S		
C1109,112	nsp	C,FILM 0.0082UF	1911E2	D02082206C060S		
OTHERS PARTS GROUP						
BD800,801	nsp	COIL,BEAD CBW160808U121T		D340160811210S		
CN2	nsp	CN.FPC 19P		L131019000010S		*
CN4	nsp	CN,WAFER 19P		L109012511910S		*
CN5	nsp	CN,WAFER 17P		L109012511710S		*
CN401	nsp	CN,WIRE 2MM 290MM/13P		L002291132620S		*
CP5	nsp	CN,WAFER 11P		L109012511110S		*
CP8	nsp	CN,WAFER 25P		L109012512510S		*
CP10	nsp	CN,WAFER 17P		L109012511710S		*
CP11	nsp	CN,WAFER 27P		L109012512710S		*
CP800	963183012380S	TUNER,FM/AM KST-MW004MV1-S63SV	791E3	E903004100031S		*
CP801	963183011320S	TUNER,FM/AM KST-MT104MV1-2	1911E2	E903104100110S		*
CP801	963183011300S	TUNER,FM/AM KST-MT004MV1-2	1911E1C,791EA	E903004100110S		*
JK101	963643010330S	TER,RCA 6PIN		G603615A0700YS		
JK102	963643010320S	TER,RCA 6PIN		G603615A0207YS		
JK103	00D963014600S	TER,RCA 1PIN	1911E2,1911E1C,791E3,791EA	G600107A0000YS		
JK103	963643010550S	TER,RCA 3PIN	1911E3	G606305B1200YS		
JK104	963643010350S	TER,RCA 3PIN		G606305B1400YS		
JK105	963643010310S	TER,RCA 1PIN		G600000020020S		
JK108	963643010340S	TER,RCA 3PIN	1911E3,1911E2,1911E1C,791E3,791EA	G606305B0200YS		
L801	nsp	COIL INDUCTOR 33UH		D330330700520S		
L1000,1001	nsp	FILTER,LC MPX	1911E2	E401010020020S		
X800	00D9630217400	CRYSTAL 14.31818MHZ		E80014R318080S		

PCB HDMI ASS'Y

Ref. No.	Part No.	Part Name	Remarks	Q'ty	New
SEMICONDUCTORS GROUP					
U1001	nsp	IC ADV7840		J040784005510S	
U1301	00D9630244907	IC SN74LV14APWR		J040741400180S	
U1302	nsp	IC ABT1030		J080103005510S	
U1303	nsp	IC MEMORY-RAM (IS42S16400F-6TL)	NOTE : When update Firmware, please confirm a last version in SDI. Use the service board after updating it.	J001421640060S	
U1501	963239010410S	IC ADV7511BSTZ-225		J040751100010S	*
U1703	00D2623077900	IC TC74VHCU04FT		J040740405580S	
U1706	236810062608S	IC LC89058W-E		J046890580020S	
U1707	963243010640S	IC PAL/PLD (EPM3032A-TC44)		8952161100040	*
U1901	nsp	IC ADSP21367KSWZ2A1181		J080213675520S	
U1902	963239010680S	IC W9864G2IH-6		J001986460060S	*
U1903	963243010650S	IC MEMORY FLASH (EN29LV160BB-70TIP)		8952161100030	
U2101	236810086505S	IC AK5358BET-E2		J043535805520S	*
U2102	236810073509S	IC AK4358VQ-L		J042435800010S	
U2103-2106	963239001880S	IC AZ4580M		J121458000020S	
U2301	963243010660S	IC MEMORY FLASH (EN29LV160BT-70TIP)		8952161100050	*
U2302	963239010380S	IS42S16400F-6TL		J001421640060S	
U2303	nsp	IC MFI341S2164		J044341216410S	
U2304	963239008830S	IC TCC8600 32BIT		J085860000010S	
U2305	236810070500S	IC AK4424ET-E2 TSSOP16		J042442405520S	
U2306	00D2790055907	SW,POLY MICROSMD175F		G300017500010S	
U2501-2503	nsp	IC EX3AV		J048030030010S	*
U2504,2505	231310009508S	IC PQ033DNA1ZPH		J126033010010S	
U2506	234810015507S	IC BU4248F		J126424800010S	
U2901	00MHC007805KZ	IC TC74VHCT125AFT		J040741255580S	
U2902	234810014504S	IC MC14094BDTR2G		J040140940020S	
U2903	00D2623437906	IC TC74VHCT244AFT		J040742445540S	
U2904	00D2623410907	IC TC74VHCT08AFT		J040740800090S	
U2905	00D2623444902	IC TC74VHC08FT		J040740800280S	
U3102	963243010620S	IC CPU MICRO PROCESS (R5F64169DFD)		8952161100010	
U3103	246810026500S	IC R1EX24256ASAS0A		J000242565550S	
U3301	963243010630S	IC CPU MICRO PROCESS (R5F3650KNFB)		8952191100010	*
Q1001	00D9630120801	TR 2SC KRC102S (NB)		J522010200210S	
Q1002	00D9600285006	TR KRC104S (ND)		J522104S00210S	
Q1003	00D9630120801	TR 2SC KRC102S (NB)		J522010200210S	
Q1004	00D9600285006	TR KRC104S (ND)		J522104S00210S	
Q1005	00D9630120801	TR 2SC KRC102S (NB)		J522010200210S	
Q1006	00D9600285006	TR KRC104S (ND)		J522104S00210S	
Q1007	00D9630120801	TR 2SC KRC102S (NB)		J522010200210S	
Q1008,1009	00D9600285006	TR KRC104S (ND)		J522104S00210S	
Q1301	00D9600285006	TR KRC104S (ND)		J522104S00210S	
Q1302	00D2750110905	SEMI HN1K02FU		J543102000020S	
Q1501	00D9630120704	TR KRA102S(PB)		J520010200210S	
Q1502	00D9630120801	TR 2SC KRC102S (NB)		J522010200210S	
Q1901	00D9630120801	TR 2SC KRC102S (NB)		J522010200210S	
Q1902	00D9630120704	TR KRA102S(PB)		J520010200210S	

	Ref. No.	Part No.	Part Name	Remarks		Q'ty	New
	Q2302,2303	00D9630120801	TR 2SC KRC102S (NB)		J522010200210S		
	Q2304	963219004200S	CHIP FDC608PZ P-CH		J543608000010S		
	Q2305	00D9630120704	TR KRA102S(PB)		J520010200210S		
	Q2507-2514	00D9630121402	TR KRA104S		J520010400210S		
	Q2515-2522	963219004200S	CHIP FDC608PZ P-CH		J543608000010S		
	Q2523-2524	00D2710326904	TR 2SA 2SA1954		J520195405510S		
	Q2525	963209011260S	D,SWITCHING DAN202U		K005020200200S		
	Q2526-2527	00D2710326904	TR 2SA 2SA1954		J520195405510S		
	Q2528-2532	00D9630120801	TR 2SC KRC102S (NB)		J522010200210S		
	Q2533	00D9630121509	TR KTC3875S		J522038750210S		
	Q2536	00D9630120801	TR 2SC KRC102S (NB)		J522010200210S		
	Q2537	00D9600285006	TR KRC104S (ND)		J522104S00210S		
	Q2540	00D9630120801	TR 2SC KRC102S (NB)		J522010200210S		
	Q2541	00D9600285006	TR KRC104S (ND)		J522104S00210S		
	Q2542	00D9630120801	TR 2SC KRC102S (NB)		J522010200210S		
	Q2543	00D9600285006	TR KRC104S (ND)		J522104S00210S		
	Q2549	00D9630120801	TR 2SC KRC102S (NB)		J522010200210S		
	Q2550	00D9600285006	TR KRC104S (ND)		J522104S00210S		
	Q2901	00D9630120801	TR 2SC KRC102S (NB)		J522010200210S		
	Q2902	nsp	SEMI KTA1504S		J520015040150S		
	Q2903,2904	00D9630121509	TR KTC3875S		J522038750210S		
	Q2905	nsp	SEMI KTA1504S		J520015040150S		
	Q2906-2910	00D9630121509	TR KTC3875S		J522038750210S		
	Q3101	00D9630120801	TR 2SC KRC102S (NB)		J522010200210S		
	Q3102	00D9630328302	TR KTC3875G	1911E3	J5223875G0210S		
	Q3103	00D9630121402	TR KRA104S	1911E3	J520010400210S		
	Q3106-3109	00D9630121402	TR KRA104S		J520010400210S		
	Q3110	00D9630120801	TR 2SC KRC102S (NB)		J522010200210S		
	Q3301	00D9630121509	TR KTC3875S		J522038750210S		
	Q3302	00D9630120704	TR KRA102S(PB)		J520010200210S		
	Q3303	963219002180S	TR 2SD2114KT146W		J5232114K0010S		
	Q3304	00D9630120801	TR 2SC KRC102S (NB)		J522010200210S		
	Q3305	00D9630121509	TR KTC3875S		J522038750210S		
	Q3306	00D9630120801	TR 2SC KRC102S (NB)		J522010200210S		
	D1502	963209010450S	D,ESD VCH4AG100R8MAT		K067040100080S		*
	D2501	00D9630355401	D,SWITCHING KDS4148U		K005041480030S		
	D2502	00D9630328603	D,SCHOTTKY RB521S-30		K125521300010S		
	D3102	00D9630355401	D,SWITCHING KDS4148U	1911E3	K005041480030S		
	D3103	00D9630355401	D,SWITCHING KDS4148U		K005041480030S		
	D3107	00D9630355401	D,SWITCHING KDS4148U		K005041480030S		
	D3110	00D9630328603	D,SCHOTTKY RB521S-30	1911E3	K125521300010S		
	D3301	00D9630355401	D,SWITCHING KDS4148U		K005041480030S		
RESISTORS GROUP							
	R2906	nsp	R,CHIP 33-J,1/16W	1911E2	C20003306M101S		
	R3119	nsp	R,CHIP 10k-J,1/16W	1911E1C	C20001036M160S		
	R3119	nsp	R,CHIP 3.3k-J,1/16W	791E3	C20003326M160S		
	R3119	nsp	R,CHIP 18k-J,1/16W	791EA	C20001836M160S		
	R3122	nsp	R,CHIP 10k-J,1/16W	1911E2, 1911E1C	C20001036M160S		
	R3122	nsp	R,CHIP 18k-J,1/16W	791E3	C20001836M160S		
	R3122	nsp	R,CHIP 3.3k-J,1/16W	791EA	C20003326M160S		

Ref. No.	Part No.	Part Name	Remarks	Q'ty	New
CAPACITORS GROUP					
C1001-1007	nsp	C,CERAMIC 0.1UF-K/50V		D011104177101S	
C1008	nsp	C,CERAMIC 0.01UF-K/25V		D011103774102S	
C1009-1012	nsp	C,CERAMIC 0.1UF-K/50V		D011104177101S	
C1013,1014	nsp	C,CERAMIC 12PF-J/50V		D011120167101S	
C1015,1016	nsp	C,CERAMIC 15PF-J/50V		D011150167101S	
C1017	nsp	C,CERAMIC 0.1UF-K/50V		D011104177101S	
C1018	nsp	C,CERAMIC 1000PF-K/50V		D011102177101S	
C1019	nsp	C,CERAMIC 4.7UF-K/6.3V		D011475571160S	
C1022-1029	nsp	C,CERAMIC 0.1UF-K/50V		D011104177101S	
C1037	nsp	C,CERAMIC 4.7UF-K/6.3V		D011475571160S	
C1039,1040	nsp	C,CERAMIC 0.1UF-K/50V		D011104177101S	
C1041	nsp	C,CERAMIC 4.7UF-K/6.3V		D011475571160S	
C1042	nsp	C,CERAMIC 0.1UF-K/50V		D011104177101S	
C1044,1045	nsp	C,CERAMIC 0.1UF-K/50V		D011104177101S	
C1047	nsp	C,CERAMIC 0.1UF-K/50V		D011104177101S	
C1055,1056	nsp	C,CERAMIC 10UF-K/16V		D011106573200S	
C1057	nsp	C,CERAMIC 0.1UF-K/50V		D011104177101S	
C1058	nsp	C,CERAMIC 10UF-K/16V		D011106573200S	
C1059	nsp	C,CERAMIC 0.1UF-K/50V		D011104177101S	
C1060	nsp	C,CERAMIC 10UF-K/16V		D011106573200S	
C1061	nsp	C,CERAMIC 0.1UF-K/50V		D011104177101S	
C1063	nsp	C,CERAMIC 4.7UF-K/6.3V		D011475571160S	
C1066-1070	nsp	C,CERAMIC 0.1UF-K/50V		D011104177101S	
C1073	nsp	C,CERAMIC 4.7UF-K/6.3V		D011475571160S	
C1075-1077	nsp	C,CERAMIC 0.1UF-K/50V		D011104177101S	
C1078	nsp	C,CERAMIC 4.7UF-K/6.3V		D011475571160S	
C1079	nsp	C,CERAMIC 0.1UF-K/50V		D011104177101S	
C1081,1082	nsp	C,CERAMIC 0.1UF-K/50V		D011104177101S	
C1083	nsp	C,CERAMIC 0.082UF-K/16V		D011823773161S	
C1084	nsp	C,CERAMIC 0.01UF-K/50V		D011103777160S	
C1085	nsp	C,CERAMIC 0.82UF-K/10V		D011824772162S	
C1086	nsp	C,CERAMIC X7R0.039UF-K/50V		D011393707160S	
C1087	nsp	C,CERAMIC 0.01UF-K/25V		D011103774102S	
C1088,1089	nsp	C,CERAMIC 0.1UF-K/50V		D011104177101S	
C1090	nsp	C,CERAMIC 10UF-K/16V		D011106573200S	
C1091-1093	nsp	C,CERAMIC 0.1UF-K/50V		D011104177101S	
C1094	nsp	C,CERAMIC 0.01UF-K/25V		D011103774102S	
C1095	nsp	C,CERAMIC 0.1UF-K/50V		D011104177101S	
C1102,1103	nsp	C,CERAMIC 0.1UF-K/50V		D011104177101S	
C1105	nsp	C,CERAMIC 0.1UF-K/50V		D011104177101S	
C1107	nsp	C,CERAMIC 0.1UF-K/50V		D011104177101S	
C1109	nsp	C,CERAMIC 0.1UF-K/50V		D011104177101S	
C1122	nsp	C,CERAMIC 4.7UF-K/6.3V		D011475571160S	
C1124	nsp	C,CERAMIC 4.7UF-K/6.3V		D011475571160S	
C1125	nsp	C,CERAMIC 0.1UF-K/50V		D011104177101S	
C1127-1130	nsp	C,CERAMIC 0.1UF-K/50V		D011104177101S	
C1301-1303	nsp	C,CERAMIC 1000PF-K/50V		D011102177101S	
C1304,1305	nsp	C,CERAMIC 9PF-D/50V		D011090117101S	
C1306	nsp	C,CERAMIC 1000PF-K/50V		D011102177101S	
C1307	nsp	C,CERAMIC 0.1UF-K/50V		D011104177101S	
C1308,1309	nsp	C,CERAMIC 4.7UF-K/6.3V		D011475571160S	
C1310-1312	nsp	C,CERAMIC 0.1UF-K/50V		D011104177101S	

	Ref. No.	Part No.	Part Name	Remarks		Q'ty	New
	C1313,1314	nsp	C,CERAMIC 4.7UF-K/6.3V		D011475571160S		
	C1315	nsp	C,CERAMIC 0.1UF-K/50V		D011104177101S		
	C1316,1317	nsp	C,CERAMIC 4.7UF-K/6.3V		D011475571160S		
	C1318-1320	nsp	C,CERAMIC 0.1UF-K/50V		D011104177101S		
	C1321,1322	nsp	C,CERAMIC 1000PF-K/50V		D011102177101S		
	C1323-1338	nsp	C,CERAMIC 0.1UF-K/50V		D011104177101S		
	C1339-1341	nsp	C,CERAMIC 1000PF-K/50V		D011102177101S		
	C1342	nsp	C,CERAMIC 0.1UF-K/50V		D011104177101S		
	C1343	nsp	C,CERAMIC 4.7UF-K/6.3V		D011475571160S		
	C1344-1348	nsp	C,CERAMIC 0.1UF-K/50V		D011104177101S		
	C1501	nsp	C,CERAMIC 0.1UF-K/50V		D011104177101S		
	C1502	nsp	C,CERAMIC 10UF-K/16V		D011106573200S		
	C1505-1508	nsp	C,CERAMIC 0.1UF-K/50V		D011104177101S		
	C1509	nsp	C,CERAMIC 10UF-K/16V		D011106573200S		
	C1512-1515	nsp	C,CERAMIC 0.1UF-K/50V		D011104177101S		
	C1516	nsp	C,CERAMIC 4.7UF-K/6.3V		D011475571160S		
	C1519,1520	nsp	C,CERAMIC 0.1UF-K/50V		D011104177101S		
	C1521	nsp	C,CERAMIC 10UF-K/16V		D011106573200S		
	C1524-1526	nsp	C,CERAMIC 1UF-K/10V		D011105772161S		
	C1701-1703	nsp	C,CERAMIC 0.1UF-K/50V		D011104177101S		
	C1706,1707	nsp	C,CERAMIC 0.01UF-K/25V		D011103774102S		
	C1708	nsp	C,CERAMIC 4.7UF-K/6.3V		D011475571160S		
	C1709	nsp	C,CERAMIC 0.1UF-K/50V		D011104177101S		
	C1710	nsp	C,CERAMIC 1000PF-K/50V		D011102177101S		
	C1711-1713	nsp	C,CERAMIC 0.1UF-K/50V		D011104177101S		
	C1714,1715	nsp	C,CERAMIC 10PF-D/50V		D011100117101S		
	C1716,1717	nsp	C,CERAMIC 0.1UF-K/50V		D011104177101S		
	C1718	nsp	C,CERAMIC 4.7UF-K/6.3V		D011475571160S		
	C1720	nsp	C,CERAMIC 1000PF-K/50V		D011102177101S		
	C1721	nsp	C,CERAMIC 0.1UF-K/50V		D011104177101S		
	C1722	nsp	C,CERAMIC 0.022UF-K/25V		D011223777160S		
	C1723-1728	nsp	C,CERAMIC 0.1UF-K/50V		D011104177101S		
	C1901-1910	nsp	C,CERAMIC 0.1UF-K/50V		D011104177101S		
	C1919-1941	nsp	C,CERAMIC 0.1UF-K/50V		D011104177101S		
	C1942	nsp	C,CERAMIC 4.7UF-K/6.3V		D011475571160S		
	C1943	nsp	C,CERAMIC 0.1UF-K/50V		D011104177101S		
	C1944	nsp	C,CERAMIC 4.7UF-K/6.3V		D011475571160S		
	C1945	nsp	C,CERAMIC 0.1UF-K/50V		D011104177101S		
	C1948-1953	nsp	C,CERAMIC 0.1UF-K/50V		D011104177101S		
	C1954	nsp	C,CERAMIC 4.7UF-K/6.3V		D011475571160S		
	C1955-1960	nsp	C,CERAMIC 0.1UF-K/50V		D011104177101S		
	C1961-1963	nsp	C,CERAMIC 4.7UF-K/6.3V		D011475571160S		
	C1965	nsp	C,CERAMIC 0.1UF-K/50V		D011104177101S		
	C1966,1967	nsp	C,CERAMIC 7PF-C/50V		D011070117101S		
	C1968-1981	nsp	C,CERAMIC 0.1UF-K/50V		D011104177101S		
	C2101	nsp	C,CERAMIC 4.7UF-K/6.3V		D011475571160S		
	C2103	nsp	C,CERAMIC 1UF-K/10V		D011105772161S		
	C2105	nsp	C,CERAMIC 4.7UF-K/6.3V		D011475571160S		
	C2106	nsp	C,CERAMIC 1UF-K/10V		D011105772161S		
	C2107-2108	nsp	C,CERAMIC 0.1UF-K/16V		D011102177101S		
	C2109-2128	nsp	C,CERAMIC 0.1F-K/16V		D011102177101S		
	C2129,2130	00D9630338606	C,ELECT 10UF-MVG/16V		D050100083470S		
	C2131	nsp	C,CERAMIC 0.1F-K/16V		D011102177101S		

Ref. No.	Part No.	Part Name	Remarks	Q'ty	New
C2132,2133	nsp	C,CERAMIC 0.01UF-K/50V		D011103777160S	
C2135	nsp	C,CERAMIC 4.7UF-K/6.3V		D011475571160S	
C2136	963134000450S	C,ELECT 100UF-MVG/16V		D050101083660S	
C2137,2138	nsp	C,CERAMIC X7R3900PF-K/50V		D011392777160S	
C2139	nsp	C,CERAMIC X7R2700PF-K/50V		D011272777160S	
C2140-2142	nsp	C,CERAMIC X7R3900PF-K/50V		D011392777160S	
C2143,2144	nsp	C,CERAMIC X7R2700PF-K/50V		D011272777160S	
C2145-2160	nsp	C,CERAMIC 470PF-J/50V		D010471167160S	
C2161,2162	963134000450S	C,ELECT 100UF-MVG/16V		D050101083660S	
C2302	nsp	C,CERAMIC 1000PF-K/50V		D011102177101S	
C2303-2311	nsp	C,CERAMIC 0.1UF-K/16V		D011102177101S	
C2312	nsp	C,CERAMIC 1000PF-K/50V		D011102177101S	
C2313	nsp	C,CERAMIC 0.1UF-K/16V		D011102177101S	
C2315	nsp	C,CERAMIC 4.7UF-K/6.3V		D011475571160S	
C2321-2323	nsp	C,CERAMIC 0.1UF-K/16V		D011102177101S	
C2328	nsp	C,CERAMIC 1000PF-K/50V		D011102177101S	
C2329	nsp	C,CERAMIC 100PF-J/50V		D011101167101S	
C2330-2334	nsp	C,CERAMIC 0.1UF-K/16V		D011102177101S	
C2335	nsp	C,CERAMIC 1000PF-K/50V		D011102177101S	
C2336	nsp	C,CERAMIC 390PF-K/50V		D011391177101S	
C2337-2339	nsp	C,CERAMIC 0.1UF-K/16V		D011102177101S	
C2340	nsp	C,CERAMIC 1200PF-K/50V		D011122177101S	
C2341-2343	nsp	C,CERAMIC 0.1UF-K/16V		D011102177101S	
C2344	nsp	C,CERAMIC 4.7UF-K/6.3V		D011475571160S	
C2348-2350	nsp	C,CERAMIC 0.1UF-K/16V		D011102177101S	
C2354,2355	nsp	C,CERAMIC 22PF-J/50V		D011220167101S	
C2356	nsp	C,CERAMIC 1UF-K/10V		D011105772161S	
C2358	nsp	C,CERAMIC 0.1UF-K/16V		D011102177101S	
C2359	nsp	C,CERAMIC 1UF-K/10V		D011105772161S	
C2360-2363	nsp	C,CERAMIC 4.7UF-K/6.3V		D011475571160S	
C2364,2365	nsp	C,CERAMIC 2200PF-K/50V		D011222777160S	
C2366	nsp	C,CERAMIC 0.1UF-K/16V		D011102177101S	
C2369-2370	nsp	C,CERAMIC 100PF-J/50V		D011101167101S	
C2501-2503	nsp	C,CERAMIC 0.1UF-K/16V		D011102177101S	
C2513-2515	nsp	C,CERAMIC 10UF-K/16V		D011106573200S	
C2516-2518	nsp	C,CERAMIC 0.01UF-K/25V		D011103774102S	
C2319-2321	nsp	C,CERAMIC 100PF-J/50V		D011101167101S	
C2522-2527	nsp	C,CERAMIC 10UF-K/16V		D011106573200S	
C2528-2530	nsp	C,CERAMIC 15PF-J/50V		D011150167101S	
C2537-2544	nsp	C,CERAMIC 0.01UF-K/25V		D011103774102S	
C2545-2552	nsp	C,CERAMIC 0.1UF-K/16V		D011102177101S	
C2553-2556	nsp	C,CERAMIC 1UF-K/10V		D011105772161S	
C2559	nsp	C,CERAMIC X7R0.015UF-K/50V		D011153777160S	
C2560	00D9630325402	C,ELECT 470UF-MVG/6.3V		D050471081200S	
C2561-2562	nsp	C,CERAMIC 0.1UF-K/16V		D011102177101S	
C2564	nsp	C,CERAMIC 1UF-K/10V		D011105772161S	
C2565-2566	nsp	C,CERAMIC 0.1UF-K/16V		D011102177101S	
C2569	nsp	C,CERAMIC 0.1UF-K/16V		D011102177101S	
C2572	nsp	C,CERAMIC 1000PF-K/50V		D011102177101S	
C2715-2724	nsp	C,CERAMIC 0.1UF-K/16V		D011102177101S	
C2725	nsp	C,CERAMIC 470PF-K/50V		D011471177101S	
C2726	nsp	C,CERAMIC 0.1UF-K/16V		D011102177101S	
C2727	nsp	C,CERAMIC 470PF-K/50V		D011471177101S	

	Ref. No.	Part No.	Part Name	Remarks		Q'ty	New
	C2728	nsp	C,CERAMIC 0.1UF-K/16V		D011102177101S		
	C2729,2730	nsp	C,CERAMIC 470PF-K/50V		D011471177101S		
	C2901-2903	nsp	C,CERAMIC 0.1UF-K/16V		D011102177101S		
	C2906-2908	nsp	C,CERAMIC 0.1UF-K/16V		D011102177101S		
	C2909	nsp	C,CERAMIC 0.01UF-K/25V		D011103774102S		
	C2910	nsp	C,CERAMIC 0.1UF-K/16V		D011102177101S		
	C2911-2914	nsp	C,CERAMIC 0.01UF-K/25V		D011103774102S		
	C3101	nsp	C,CERAMIC 0.1UF-K/16V		D011102177101S		
	C3102	nsp	C,CERAMIC 1000PF-K/50V	1911E3	D011102177101S		
	C3103	nsp	C,CERAMIC 0.1UF-K/16V	1911E3	D011104177101S		
	C3104	nsp	C,CERAMIC 1000PF-K/50V	1911E3	D011102177101S		
	C3111-3113	nsp	C,CERAMIC 0.1UF-K/16V		D011102177101S		
	C3114	nsp	C,CERAMIC 4.7UF-K/6.3V		D011475571160S		
	C3120	nsp	C,CERAMIC 4.7UF-K/6.3V		D011475571160S		
	C3121	nsp	C,CERAMIC 0.1UF-K/16V		D011102177101S		
	C3122,3123	nsp	C,CERAMIC 10PF-D/50V		D011100117101S		
	C3124-3128	nsp	C,CERAMIC 0.1UF-K/16V		D011102177101S		
	C3301-3302	nsp	C,CERAMIC 0.1UF-K/16V		D011102177101S		
	C3303,3304	nsp	C,CERAMIC T.C COG10PF-D/50V		D010100117160S		
	C3305-3306	nsp	C,CERAMIC 0.1UF-K/16V		D011102177101S		
	C3307	nsp	C,CERAMIC 4.7UF-K/6.3V		D011475571160S		
	C3315	nsp	C,CERAMIC 0.1UF-K/16V		D011102177101S		
	C3316	nsp	C,CERAMIC 220PF-K/50V		D011221177101S		
	C3317	nsp	C,CERAMIC 0.1UF-K/16V		D011102177101S		
	C9151-9155	nsp	C,CERAMIC 1000PF-K/50V		D011102177101S		
OTHERS PARTS GROUP							
	L1001	nsp	COIL,BEAD CBW160808U121T		D340160811210S		
	L1301-1303	nsp	COIL,BEAD CBW160808U121T		D340160811210S		
	L1501-1503	nsp	COIL,CHIP FLC32C220K		D307322205520S		
	L2301-2303	nsp	COIL,BEAD BLM21PG221SN1		D340201212210S		
	L2501-2506	nsp	COIL,BEAD BLM21PG221SN1		D340201212210S		
	L2513-2515	nsp	COIL,BEAD BLM21PG221SN1		D340201212210S		
	L2516	nsp	COIL,BEAD CBW160808U121T		D340160811210S		
	L2767,2768	nsp	R,THICK 0-J,1/16W		C20000006M160S		
	X1001,1002	141810044504S	CRYSTAL CHIP FCX-04(28.63636MHz)		E80528R636380S		*
	X1301	141810045507S	CRYSTAL CHIP FCX-04(27MHz)		E80527R000080S		*
	X1701	141810046500S	CRYSTAL CHIP FCX-04(24.576MHz)		E80524R576080S		*
	X1902	141810047503S	CRYSTAL CHIP FCX-04(20.815MHz)		E80520R815080S		*
	X2302	963141010270S	CRYSTAL CHIP FCX-04C(12MHz)		E80512R000080S		*
	X3102	141810048506S	CRYSTAL CHIP FCX-04(16MHz)		E80516R000080S		*
	X3302	141810048506S	CRYSTAL CHIP FCX-04(16MHz)		E80516R000080S		*
	Z1	nsp	CLAMP STYLE PIN 1P		4330210162000S		
	K1001-1004	644010108608S	HDMI CONNECTOR(YKF45-7074N)		L109100190450S		*
	K1501	644010108608S	HDMI CONNECTOR(YKF45-7074N)		L109100190450S		*
	K1702	00D9630237503	MODULE JSR1165-C		E100116500040S		
	K1706	963643003580S	TER,RCA 1PIN		G600107C0020YS		
	K3101	00D9630294601	JACK,D3.5 EARPHONE		G40100350000YS		
	K3102,3103	00D9630244703	JACK,D3.5 EARPHONE	1911E3	G40130802000YS		

Ref. No.	Part No.	Part Name	Remarks		Q'ty	New
N2501	nsp	CN.WAFER 5P		L102050010040S		*
N2701	nsp	CN,WAFER 19P		L109012521910S		*
N2702	nsp	CN,WAFER 17P		L109012521710S		*
N2704	nsp	CN,WAFER 19P		L109012521910S		*
N2705	nsp	CN,WAFER 17P		L109012521710S		*
N2706	nsp	CN.WAFER 5P		L101200100510S		
N2707	nsp	CN.WAFER 33P		L109012523310S		*
N2708	nsp	CN,WAFER 25P		L109012522510S		*
N2709	nsp	CN,WAFER 11P		L109012521110S		*
N2710	nsp	CN.FPC 40P		L130100220400S		*
N2901	nsp	CN.FPC 4P		L130100090440S		*
N3101	nsp	CN.FPC 11P		L130100161130S		
N3301	nsp	CN.FPC 11P		L130100161130S		
N4401	nsp	CN.WAFER 5P		L101200100510S		