

DENON

Hi-Fi Component

SERVICE MANUAL

MODEL DCD-S10

MODEL DCD-3000

STEREO CD PLAYER

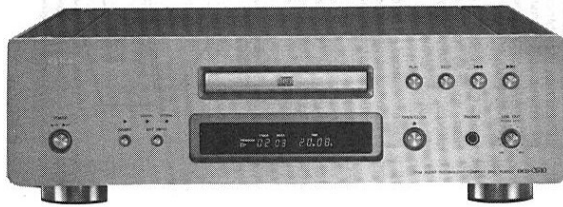

DCD-S10

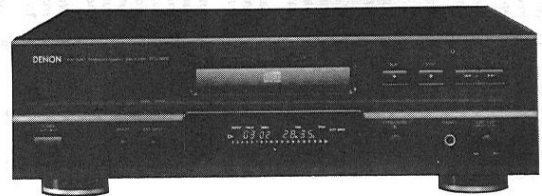

DCD-3000



— TABLE OF CONTENTS —

OPERATING INSTRUCTIONS	2 ~ 9
SPECIFICATIONS	10
DISASSEMBLY	11
ADJUSTMENT	12 ~ 15
HEAT RUN MODE FUNCTION	16
JUDGMENT STANDARDS FOR OPTICAL PICK-UP REPLACEMENT	16 ~ 20
PARTS LIST OF P.W.BOARD	21 ~ 27
IC TERMINAL FUNCTION	28 ~ 31
SEMICONDUCTORS	32 ~ 35
EXPLODED VIEW (DCD-S10 Europe, U.S.A & Canada Models)	36
PARTS LIST OF EXPLODED VIEW	37, 38
EXPLODED VIEW (DCD-S10 Asia Model)	39
EXPLODED VIEW (DCD-3000 Europe, U.S.A. & Canada and Multi-Voltage Models)	40
PARTS LIST OF EXPLODED VIEW	41
PARTS LIST OF FG-76/77 MECHANISM UNIT	42
EXPLODED VIEW OF FG-76/77 MECHANISM UNIT	42
P.W.BOARD UNIT ASS'Y	43 ~ 45
WIRING DIAGRAM	46
SCHEMATIC DIAGRAM-1/3, 2/3, 3/3	47 ~ 49

NIPPON COLUMBIA CO., LTD.

SPECIFICATIONS

AUDIO

No. of Channels:	2 channels
Frequency Response:	2 ~ 20,000 Hz
Dynamic Range:	100 dB
Signal-to-noise Ratio:	118 dB
Harmonic Distortion:	0.0018% (1 kHz)
Separation:	110 dB (1 kHz)
Wow & Flutter:	Below measurable limit: (±0.001% W.peak)
Output Voltage:	FIXED 2.0 V VARIABLE 0~2.0 V Compact Disc format

DISCS

GENERAL CHARACTERISTICS

Power Supply:	Voltage and frequency are shown on rating label.
Power Consumption:	22 W
Dimensions:	434 (W) × 135 (H) × 340 (D) mm (17-3/32" × 5-5/16" × 13-25/64")
Weight:	DCD-S10 10.0 kg (22 lbs 5oz) DCD-3000 8.0 kg (17 lbs 64oz)

FUNCTIONS AND DISPLAY

Functions:	Direct selection, automatic search, programmed playback, repeat playback, manual search, auto space, time mode, auto edit, index search, fader, peak search.
Display:	Track number, time, music calendar, and engaged modes
Others:	Headphones jack
REMOTE CONTROL UNIT	DCD-S10 RC-253 DCD-3000 RC-252
Remote Control System:	Infrared pulse system
Power Supply:	3 V DC; two R6P (standard size AA) dry cell batteries
External Dimensions:	60 (W) × 177 (H) × 18 (D) mm (2-23/64" × 6-31/32" × 45/64")
Weight:	120 g (26 oz)(including batteries)

* Design and specifications are subject to change without notice in the course of product improvement.

DISASSEMBLY

1. Top Cover

Remove 2 screws from rear side and 4 screws from both sides. Remove 4 upper screws and detach the Top Cover as show as arrow.

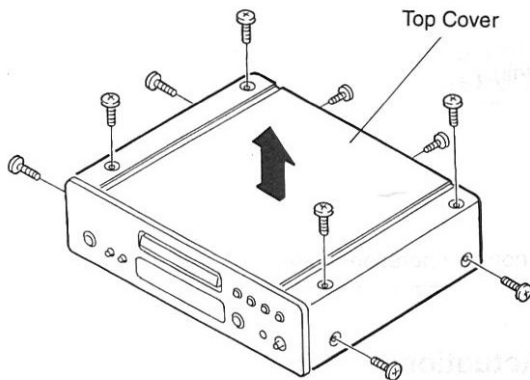

2. Front Panel

Pull out Loader Panel, remove 3 upper screws and 2 below screws, then detach the Front Panel as show as arrow.

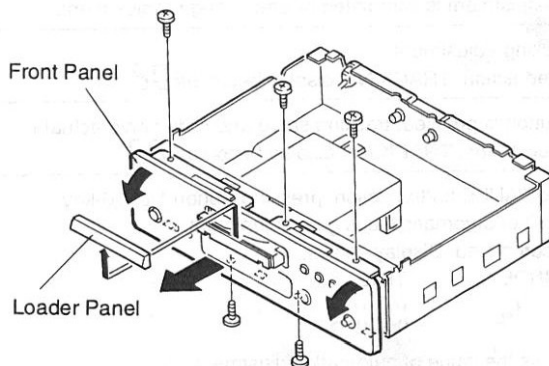

3. Bottom Cover

Remove 12 screws from bottom side, and detach Bottom Cover.

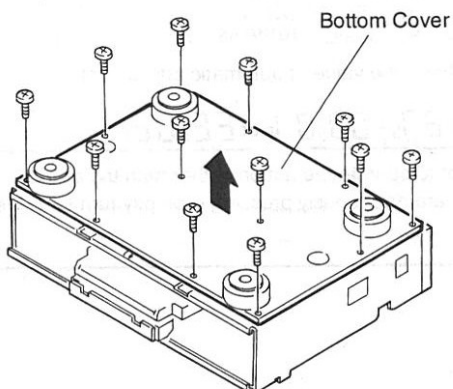

4. Mechanism Unit

Remove 4 screws and detach the Cover, then remove 4 screws and detach the Mechanism Unit as show as arrow.

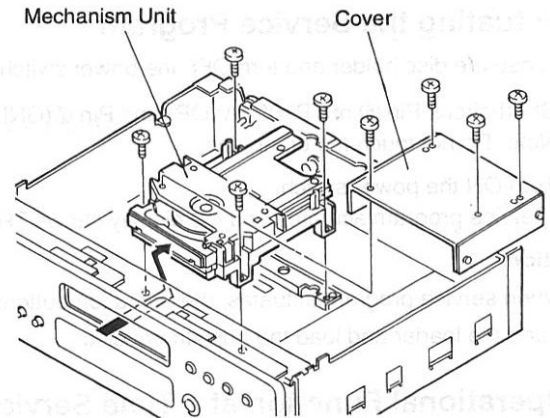

5. Clamper

Remove 4 screws and detach the Clamper.

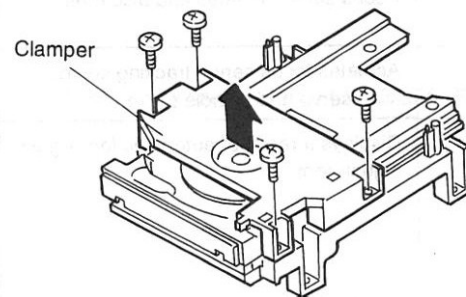

ADJUSTMENT

A microcomputer employed in this unit has a service program built-in so as to perform each servo confirmation easier with the operation buttons.

Also, the unit adopted with digital servo makes focus gain and tracking gain adjustments in automatic manner.

1. Actuating the Service Program

- (1) Close the disc holder and turn OFF the power switch.
- (2) Short-circuit Pin ⑥ of TP102(SWOP) and Pin ⑦(GND) of PWB(Main Unit).
Note: Do not touch the other pins.
- (3) Turn ON the power switch.
(Service program actuates and the display shows TRACK No. 01)

(Caution)

- When service program actuates, the operation buttons will not function normal operation mode.
- Open the loader and load the adjustment disc.

2. Operational Function at a Time Service Program Actuation

Button Operation	Function	Description						
▲ OPEN/CLOSE	Opens/closes disc holder.	<ul style="list-style-type: none"> ● Open/close operation should be performed while disc fun is in stop. ● The other keys should be operated after open/close operation is finished. 						
■ STOP	Stops system operation.	<ul style="list-style-type: none"> ● TRACK No. display becomes 01. ● Press it when adjustment is completed or attempting readjustment. 						
▶ PLAY	Focus servo actuates and disc runs.	<ul style="list-style-type: none"> ● Press it for tracking adjustment. ● When completed action, TRACK No. display becomes 02. 						
▶▶	Actuates focus servo, tracking servo, slide servo and spindle servo.	<ul style="list-style-type: none"> ● When PLAY button is pressed, tracking servo and slide servo actuate. ● When completed action, TRACK No. display becomes 03. 						
EXT. INPUT	Displays a result of automatic focus gain adjustment.	<ul style="list-style-type: none"> ● After completed PAUSE button action, pressing Button 1 of 10-key indicates a result of automatic focus gain adjustment. ● After action is completed, Display shows: <table style="margin-left: 40px;"> <tr> <td>TRACK</td> <td>INDEX</td> <td>TIME</td> </tr> <tr> <td>03</td> <td>1-</td> <td>∞∞∞∞∞∞ ∞∞∞∞∞∞</td> </tr> </table> <p>TIME display shows the value of automatic adjustment</p> <p>Displays: 0 1m27₅ ~ 00m01₅ or EE₁₁01₅</p>	TRACK	INDEX	TIME	03	1-	∞∞∞∞∞∞ ∞∞∞∞∞∞
TRACK	INDEX	TIME						
03	1-	∞∞∞∞∞∞ ∞∞∞∞∞∞						
◀◀	Displays a result of automatic tracking gain adjustment.	<ul style="list-style-type: none"> ● After completed PAUSE button action, pressing Button 2 of 10-key indicates a result of automatic tracking gain adjustment. ● After action is completed, Display shows: <table style="margin-left: 40px;"> <tr> <td>TRACK</td> <td>INDEX</td> <td>TIME</td> </tr> <tr> <td>03</td> <td>2-</td> <td>∞∞∞∞∞∞ ∞∞∞∞∞∞</td> </tr> </table> <p>TIME display shows the value of automatic adjustment.</p> <p>Displays: 0 1m27₅ ~ 00m01₅ or EE₁₁02₅</p>	TRACK	INDEX	TIME	03	2-	∞∞∞∞∞∞ ∞∞∞∞∞∞
TRACK	INDEX	TIME						
03	2-	∞∞∞∞∞∞ ∞∞∞∞∞∞						
Other Buttons	Unable to obtain normal function.	<ul style="list-style-type: none"> ● Never attempt to operate the buttons other than the above. ● If the buttons are erroneously pressed, promptly turn OFF the power switch. 						

(Caution)

- During the service program is in operation, do not use remote control.

3. Confirming Method

- (1) Required Measuring Equipment and Implement
 - a) Dual-trace oscilloscope
 - b) Test disc: CA-1094 "Yasuko TOMITA" or CO-76143 "W.A. Mozart"
- (2) Check Point

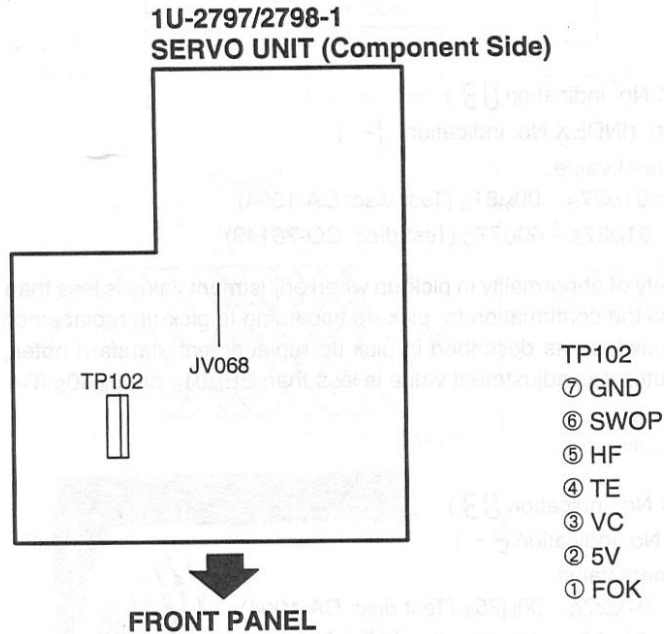

Note: About the difference of test point between Analog Servo (DCD615, etc.) and Digital Servo (DCD-S10/3000).

Analog Servo		Digital Servo
TP101	TP102	TP102
⑥ TEI	⑥ 5V	⑦ GND
⑤ VC	⑤ NC	⑥ SWOP
④ FOK	④ SWOP	⑤ HF
③ TEO	③ SWCL	④ TE
② FEI	② GND	③ VC
① FEO	① HF	② 5V
		① FOK

As described above, test points of CD player have changed from this model (DCD-S10/3000), when replacement is required for pick-up according to the pick-up replacement standard, please use the test points as follows.

Analog Servo	Digital Servo
FOK (Pin4 of TP101)	FOK (Pin1 of TP102)
FEO (Pin1 of TP101)	FE (JV068)
TEO (Pin3 of TP101)	TE (Pin4 of TP102)
HF (Pin1 of TP102)	HF (Pin5 of TP102)
VC (Pin5 of TP101)	VC (Pin3 of TP102)

(3) Confirming Procedure

- a) Actuate the service program.
- b) Check the value of automatic focus gain adjustment.
- c) Check the value of automatic tracking gain adjustment.
- d) Check for tracking offset.
- e) Finish the service program and return the mode to normal operation (turn ON the power switch in normal manner).
- f) Check for HF level.

(4) Confirming Focus Gain

Confirm the following items.

- a) Press button. (TRACK No. indication 03)
- b) Press button. (INDEX No. indication {-)
- c) Check for automatic adjustment value.
Automatic adjustment value: 01M27S ~ 00M81S (Test disc: CA-1094)
01M27S ~ 00M77S (Test disc: CO-76143)

Note: As there may have a possibility of abnormality in pick-up when adjustment value is less than EEM01S or 00M80S (CA-1094), 00M76S (CO-76143), execute the confirmation for pick-up according to pick-up replacement standard.

If there is no abnormality in pick-up as described in pick-up replacement standard notes, no problem will occur for disc playback even though the automatic adjustment value is less than EEM01S or 00M80S (CA-1094), 00M76S (CO-76143).

(5) Confirming Tracking Gain

Confirm the following items.

- a) Press button. (TRACK No. indication 03)
- b) Press button. (INDEX No. indication 2-)
- c) Check for automatic adjustment value.
Automatic adjustment value: 01M27S ~ 00M35S (Test disc: CA-1094)
01M27S ~ 00M31S (Test disc: CO-76143)

Note: As there may have a possibility of abnormality in pick-up when adjustment value is less than EEM02S or 00M34S (CA-1094), 00M30S (CO-76143), execute the confirmation for pick-up according to pick-up replacement standard.

If there is no abnormality in pick-up as described in pick-up replacement standard notes, no problem will occur for disc playback even though the automatic adjustment value is less than EEM01S or 00M34S (CA-1094), 00M30S (CO-76143).

(6) Tracking offset (E/F Balance)

Oscilloscope		Check	Step
Connection			
V	H	(Oscilloscope)	
0.1V/div	1~2 ms/div	$\frac{A - B}{A + B} < 20\%$	<ol style="list-style-type: none"> 1. Push and load disc holder reference disk. 2. Push and close disc holder. 3. Push to turn disc. (Displays track number 02) 4. Short (+)(-) of oscilloscope and check the base line. 5. Confirm that upper and lower amplitude of the waveform is symmetric against 0V.

(7) HF level

Connection			
<div style="text-align: center;"> </div>			
Oscilloscope		Check	Step
V	H	(Oscilloscope)	
50mV/div or 20mV/div	0.2μs/div or 0.5μs/div		<ol style="list-style-type: none"> 1. Push (Displays track number 03) 2. Check HF level of oscilloscope. 3. Confirm that the waveform is in good shape. (◇ pattern in center must be able to discriminate clearly.)
<ul style="list-style-type: none"> • Set input mode to ALTERNATE or CHOPPER. 			

HEAT RUN MODE FUNCTION

Heat Run Mode

(1) To activate

While hold pushing PLAY and ◀◀ keys simultaneously, turn the unit power on. The remote control sensor indicator will light to show that the unit is shifted in Heat Run mode.

Be sure to load the disc previously.

Press the disc holder open/close button (▲ OPEN/CLOSE) to cancel Heat Run mode.

★ **This mode functions only for a disc with 21 pieces of music or more. For a disc with 20 pieces of music or lesser, please do not use.**

(2) Operation

During the Heat Run mode to shift the unit in Play mode makes the unit replays from the first music after opens the loader once and re-closes it when finish playing the last track (comes into lead out).

Hereafter, operates open/close of loader, servo on, reading of TOC, and playing repeatedly, and repeats playing the two tracks; the first and the last ones.

(3) Error Message

When the system error occurs while in Heat Run mode, the following error message will display on the Track No. indicator and stops operation.

1. E1

At the time of Focus Servo does not activate.

2. E2

When unable to detect synchronous pattern however the disc is in rotating. (GFS does not drive.)

3. E3

No synchronous pattern can be detected while in Play mode. (No GFS drives.)

4. E4

When TOC is unreadable in despite of servo is activated.

5. E5

In case of loader malfunctions. (Unable to turn on the switch.)

6. E6

The inner circle switch of Pick-up does not turn off.

7. E7

The inner circle switch of Pick-up does not turn on.

★ The number of operation up to the stop will be displayed on the minute and second portion of the indicator.

JUDGMENT STANDARDS FOR OPTICAL PICK-UP REPLACEMENT

1. PICK-UP REPLACEMENT

The pick-up (PU) replacement must be executed on checking the following 4 items and found the abnormality in the PU. Also, refer to following pages.

(1) Judgment by confirming of Focus Search.

(Cause of PU abnormality: Focus search does not function from pick-up laser)

(2) Judgment by Changing of PU due to Focus Error Signal V_{FE}.

(Cause of PU abnormality: No proper emission of focus error signal (S-curve) V_{FE})

(3) Judgment by Changing of PU due to Tracking Error Signal V_{TE}.

(Cause of PU abnormality: No proper emission of tracking error signal (Traverse wave) V_{TE})

(4) Judgment by Changing of PU due to HF level V_{HF}

(Cause of PU abnormality: No proper emission of HF wave)

2. ABOUT USING DISK

Using Yasuko TOMITA disc (disc No. CA-1094) or w. A. Mozart (disc No. CO-76143)

3. PICK-UP REPLACEMENT OF OTHER CAUSE

If it happens case of another PU change except for over checking items, please execute PU replacement.

1. Judgement by Confirming of Focus Search (Check for focus searching of PU Lens)

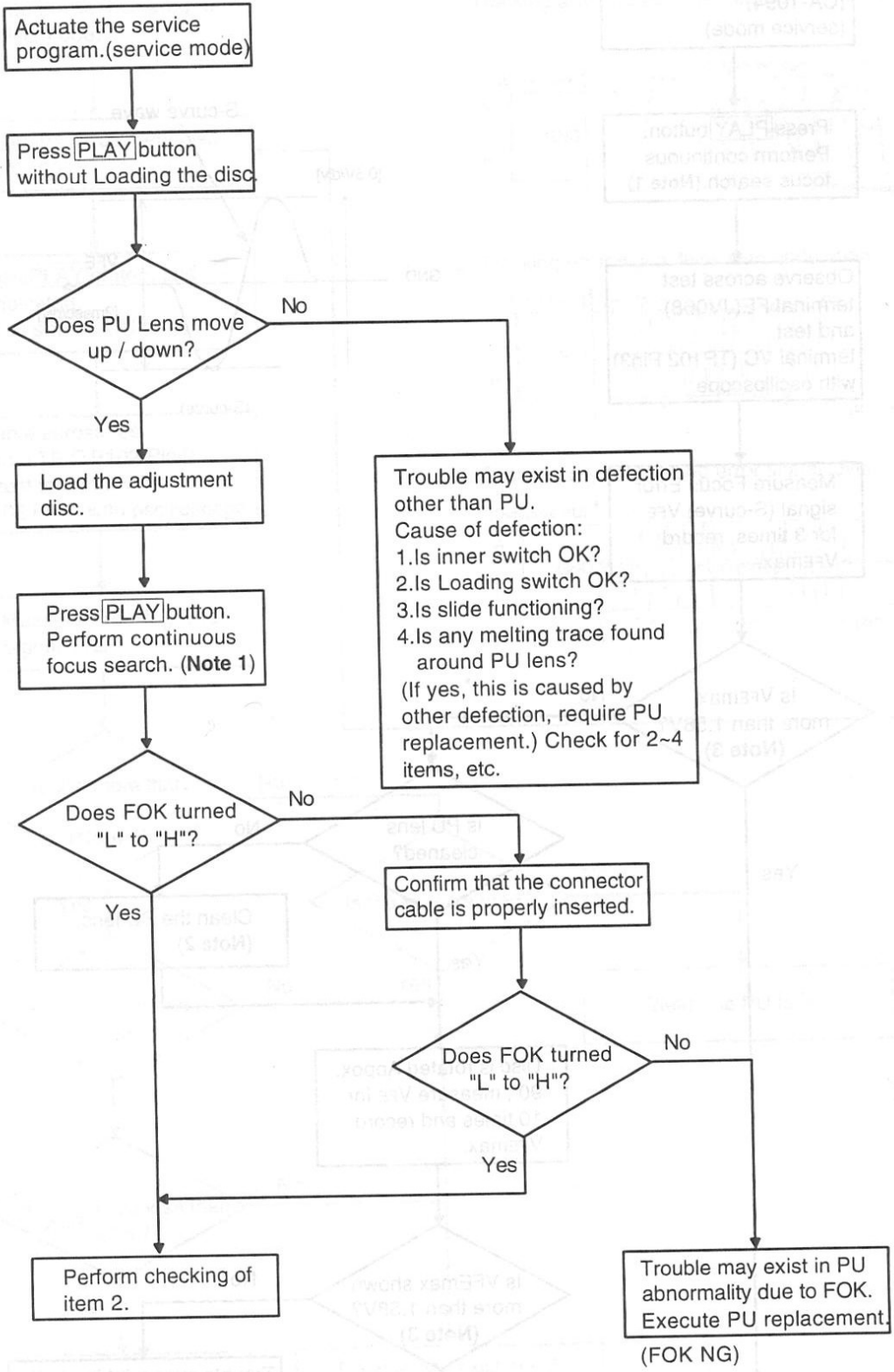

Note 1: Press **PLAY** button continuously in FOK measure.

2. Judgement by Changing of PU due to Focus Error signal (S-curve) VFE (check for proper S-curve)

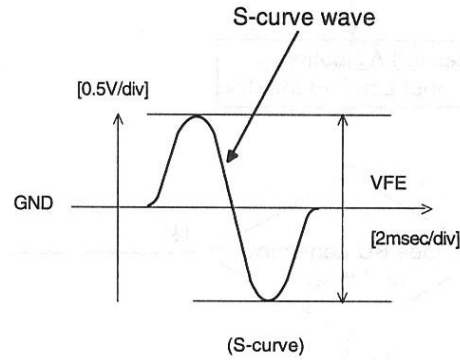
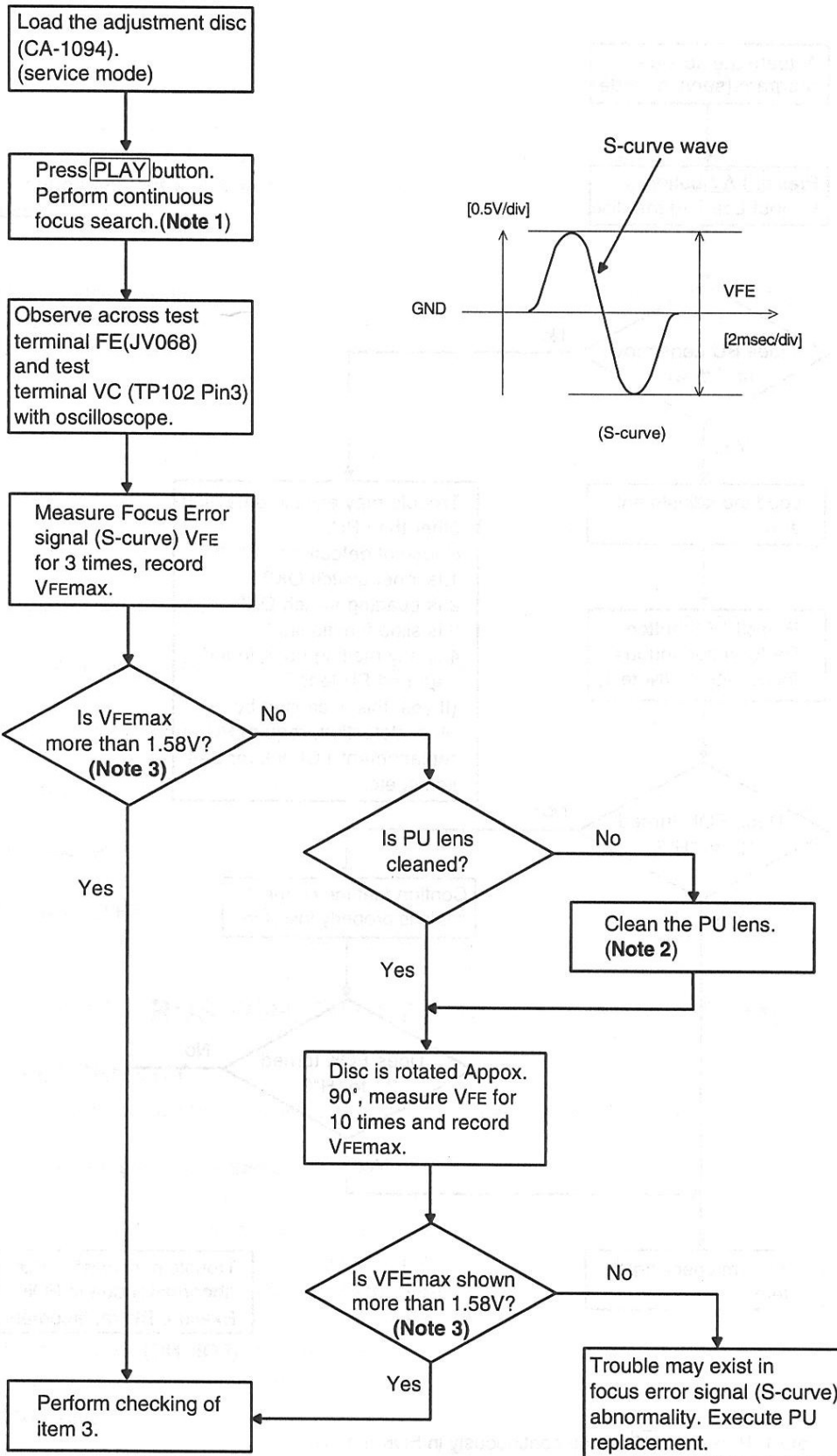

Note 1: Press **PLAY** button continuously in VFE measure.

Note 2: Clean the lens with-moistened cleaning paper without applying an excessive force to the lens.

Note 3: When using the Test disc CO-76143 value are 1.67V.

3. Judgement by changing of PU due to Tracking Error Signal VTE (check for proper Traverse wave)

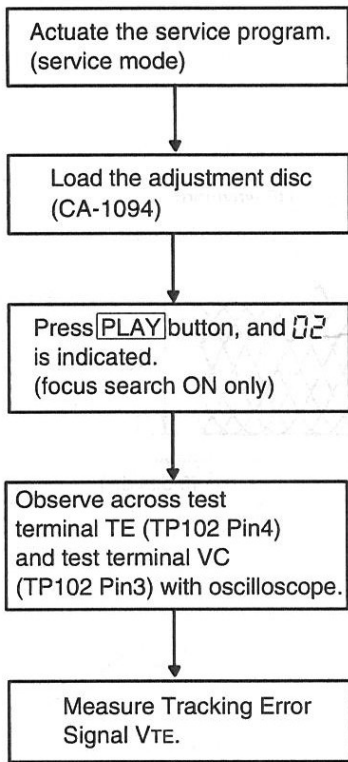

1. Tracking error signal level without undulation.

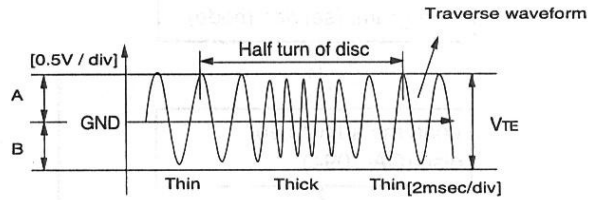

2. Tracking error signal level with undulation.

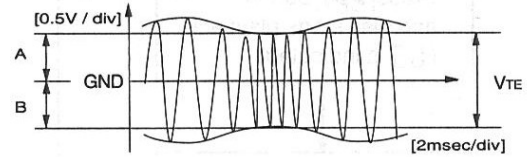

3. Occasionally no tracking error signal level.

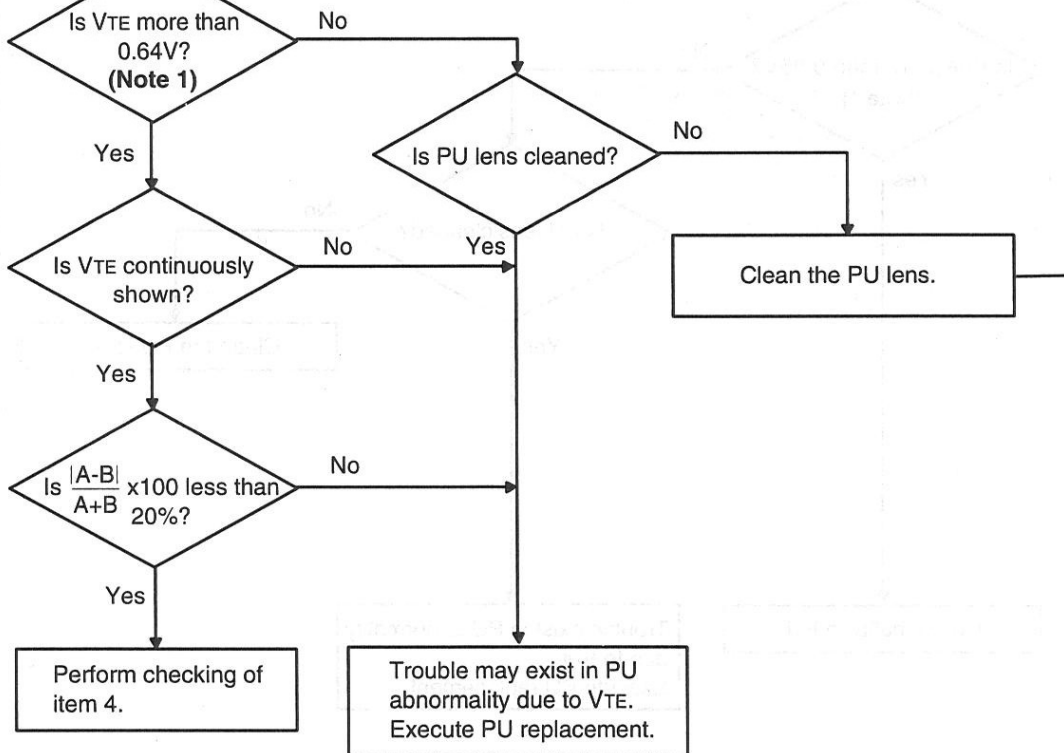
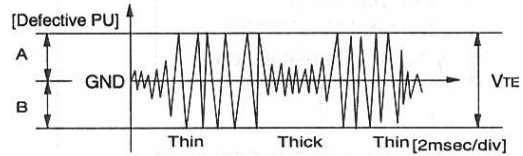

Note 1: When using the Test disc CO-76143 value are 0.70V.

**4. Judgement by changing of PU due to HF level V_{HF}
(check for proper HF wave)**

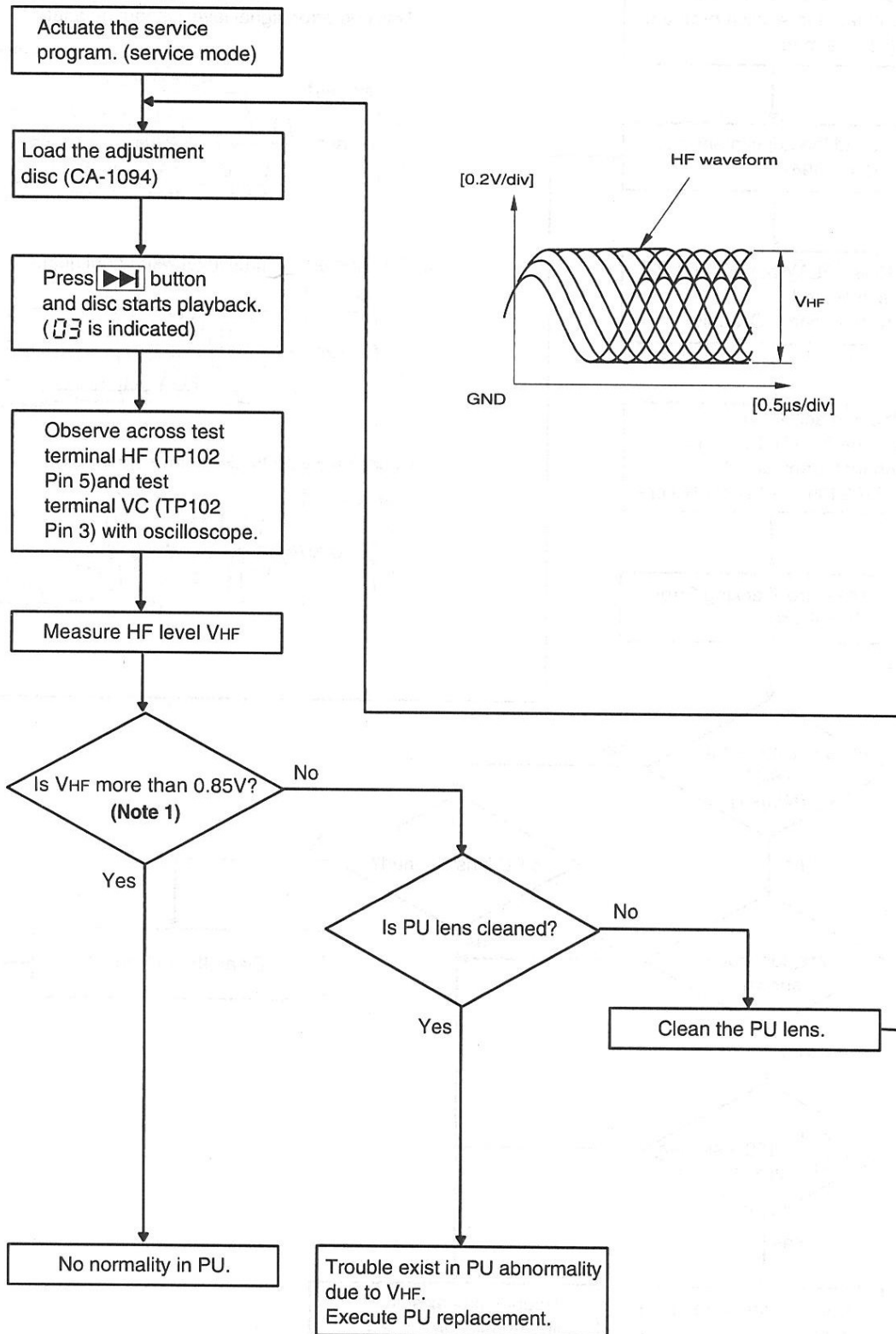

Note 1: When using the Test disc CO-76143 value are 0.85V.

NOTE FOR PARTS LIST

- Part indicated with the mark "◎" are not always in stock and possibly to take a long period of time for supplying, or in some case supplying of part may be refused.
- When ordering of part, clearly indicate "1" and "I" (i) to avoid mis-supplying.
- Ordering part without stating its part number can not be supplied.
- Part indicated with the mark "★" is not illustrated in the exploded view.
- Not including Carbon Film ±5%, 1/4W Type in the P.W.Board parts list. (Refer to the Schematic Diagram for those parts.)

WARNING:

Parts marked with this symbol  have critical characteristics.
Use ONLY replacement parts recommended by the manufacturer.

● **Resistors**

Ex.: RN 14K 2E 182 G FR

Type	Shape and performance	Power	Resistance	Allowable error	Others
RD : Carbon		2B : 1/8W	F : ±1%	P : Pulse-resistant type	
RC : Composition		2E : 1/4W	G : ±2%	NL : Low noise type	
RS : Metal oxide film		2H : 1/2W	J : ±5%	NB : Non-burning type	
RW : Winding		3A : 1W	K : ±10%	FR : Fuse-resistor	
RN : Metal film		3D : 2W	M : ±20%	F : Lead wire forming	
RK : Metal mixture		3F : 3W			
		3H : 5W			

* **Resistance**

1 8 2 ⇒ 1800 ohm = 1.8 kohm
Indicates number of zeros after effective number.
2-digit effective number.

• Units: ohm

1 R 2 ⇒ 1.2 ohm
1-digit effective number.
2-digit effective number, decimal point indicated by R.

• Units: ohm

● **Capacitors**

Ex.: CE 04W 1H 2R2 M BP

Type	Shape and performance	Dielectric strength	Capacity	Allowable error	Others
CE : Aluminum foil electrolytic		0J : 6.3V	F : ±1%	HS : High stability type	
CA : Aluminum solid electrolytic		1A : 10V	G : ±2%	BP : Non-polar type	
CS : Tantalum electrolytic		1C : 16V	J : ±5%	HR : Ripple-resistant type	
CQ : Film		1E : 25V	K : ±10%	DL : For charge and discharge	
CK : Ceramic		1V : 35V	M : ±20%	HF : For assuring high frequency	
CC : Ceramic		1H : 50V	Z : +80%	U : UL part	
CP : Oil		2A : 100V	-20%	C : CSA part	
CM : Mica		2B : 125V	P : +100%	W : UL-CSA type	
CF : Metallized		2C : 160V	-0%	F : Lead wire forming	
CH : Metallized		2D : 200V	C : ±0.25pF		
		2E : 250V	D : ±0.5pF		
		2H : 500V	= : Others		
		2J : 630V			

* **Capacity (electrolyte only)**

2 2 2 ⇒ 2200µF
Indicates number of zeros after effective number.
2-digit effective number.

• Units: µF.

2 R 2 ⇒ 2.2µF
1-digit effective number.
2-digit effective number, decimal point indicated by R.

• Units: µF.

* **Capacity (except electrolyte)**

2 2 2 ⇒ 2200pF = 0.0022µF
(More than 2) — Indicates number of zeros after effective number.
2-digit effective number.

• Units: µF.

2 2 1 ⇒ 220pF
(0 or 1) — Indicates number of zeros after effective number.
2-digit effective number.

• Units: pF.

• When the dielectric strength is indicated in AC, "AC" is included after the dielectric strength value.

PARTS LIST OF P. W. BOARD

1U-2798 DIGITAL SERVO UNIT

(1U-2798: DCD-3000, DCD-S10 Europe Model)

(1U-2798D: DCD-3000, DCD-S10, U.S.A. & Canada Models)

(1U-2798B: DCD-3000 Multi-Voltage model)

Ref. No.	Part No.	Part Name	Remarks	Ref. No.	Part No.	Part Name	Remarks
SEMICONDUCTORS GROUP							
IC101	262 1879 003	IC CXD2515Q		R118	247 0009 901	Chip Resistor 4.7kohm 1/10W	RM73B--472J
IC102	263 0909 906	IC BA6392FP		R120	247 0009 901	Chip Resistor 4.7kohm 1/10W	RM73B--472J
IC103	263 0565 007	IC BA15218		R121	247 0011 944	Chip Resistor 47kohm 1/10W	RM73B--473J
IC104	262 0910 002	IC YM3623B		R122	247 0009 956	Chip Resistor 7.5kohm 1/10W	RM73B--752J
IC105	263 0565 007	IC BA15218		R123	247 0008 999	Chip Resistor 4.3kohm 1/10W	RM73B--432J
IC110,111	262 1641 901	IC HD74HC157FP		R124	247 0005 989	Chip Resistor 220ohm 1/10W	RM73B--221J
IC201	262 2111 003	IC M38173M6-292FP		R126	247 0018 905	Chip Resistor 0ohm 1/10W	RM73B--0R0K
IC202	262 1265 002	IC TC74HCU04AP		R127	247 0018 905	Chip Resistor 0ohm 1/10W	RM73B--0R0K
IC300	262 1869 000	IC SM5845AF		R128	247 0008 960	Chip Resistor 3.3kohm 1/10W	RM73B--332J
IC350	263 0615 902	IC BA15218F		R129	247 0007 974	Chip Resistor 1.3kohm 1/10W	RM73B--132J
IC400	263 0516 001	IC NJM7812FA	Regulator +12V	R130	247 0014 967	Chip Resistor 1Mohm 1/10W	RM73B--105J
IC401	263 0539 004	IC NJM79M12FA	Regulator -12V	R131	247 0012 927	Chip Resistor 100kohm 1/10W	RM73B--104J
IC402	263 0793 002	IC NJM7806FA(S)	Regulator +6V	R132	247 0009 998	Chip Resistor 11kohm 1/10W	RM73B--113J
IC403	263 0809 006	IC NJM7805FA(S)	Regulator +5V	R133	247 0008 960	Chip Resistor 3.3kohm 1/10W	RM73B--332J
IC406,407	268 0074 904	IC Protector ICP-N20		R135	247 0008 960	Chip Resistor 3.3kohm 1/10W	RM73B--332J
IC409	263 0652 907	IC PST529C		R136	247 0007 945	Chip Resistor 1kohm 1/10W	RM73B--102J
TR101	274 0036 905	Transistor 2SD468(C)		R138	247 0009 998	Chip Resistor 11kohm 1/10W	RM73B--113J
TR102	272 0025 907	Transistor 2SB562(C)		R144,145	247 0012 943	Chip Resistor 120kohm 1/10W	RM73B--124J
TR103	269 0026 900	Transistor RN2202(10K-10K)	Built in Resistor	R146	247 0005 989	Chip Resistor 220ohm 1/10W	RM73B--221J
TR111	274 0036 905	Transistor 2SD468(C)		R147	247 0010 929	Chip Resistor 15kohm 1/10W	RM73B--153J
TR112	272 0025 907	Transistor 2SB562(C)		R148	247 0010 916	Chip Resistor 13kohm 1/10W	RM73B--133J
TR119	272 0025 907	Transistor 2SB562(C)		△R149	244 2051 945	Metal oxide film 1 ohm 1W (Non-burning type)	RS14B3A010JNBS(S)
TR120	274 0036 905	Transistor 2SD468(C)		R151	247 0009 956	Chip Resistor 7.5kohm 1/10W	RM73B--752J
TR350	273 0303 910	Transistor 2SC1740S(S)		R161	247 0012 985	Chip Resistor 180kohm 1/10W	RM73B--184J
TR401	272 0025 907	Transistor 2SB562(C)		R162	247 0011 999	Chip Resistor 75kohm 1/10W	RM73B--753J
TR402,403	269 0025 901	Transistor RN1202(10K-10K)	Built in Resistor	R192	247 0003 949	Chip Resistor 22ohm 1/10W	RM73B--220J
D101,102	276 0432 903	Diode 1SS270A		R202	247 0007 945	Chip Resistor 1kohm 1/10W	RM73B--102J
D107	276 0432 903	Diode 1SS270A		R206,207	247 0007 945	Chip Resistor 1kohm 1/10W	RM73B--102J
D203	276 0432 903	Diode 1SS270A		R209	247 0004 977	Chip Resistor 75ohm 1/10W	RM73B--750J
D402,403	276 0553 905	Diode 1SR35-200A		R214,215	247 0012 943	Chip Resistor 120kohm 1/10W	RM73B--124J
D404	276 0466 908	Zener Diode HZS7C-1	7V	R216	247 0012 927	Chip Resistor 100kohm 1/10W	RM73B--104J
D405	276 0484 906	Zener Diode HZS33-1	33V	R217	247 0005 989	Chip Resistor 220ohm 1/10W	RM73B--221J
D410-417	276 0553 905	Diode 1SR35-200A		R218	247 0004 922	Chip Resistor 47ohm 1/10W	RM73B--470J
RESISTORS GROUP (Not included Carbon Film ±5% 1/4W)				R219	247 0012 927	Chip Resistor 100kohm 1/10W	RM73B--104J
R001,002	247 0018 905	Chip Resistor 0ohm 1/10W	RM73B--0R0K	R225	247 0004 977	Chip Resistor 75ohm 1/10W	RM73B--750J
R003,004	247 0009 914	Chip Resistor 5.1kohm 1/10W	RM73B--512J	R300-302	247 0007 945	Chip Resistor 1kohm 1/10W	RM73B--102J
R005,006	247 0018 905	Chip Resistor 0ohm 1/10W	RM73B--0R0K	R350-355	247 0009 985	Chip Resistor 10kohm 1/10W	RM73B--103J
R007	247 0009 914	Chip Resistor 5.1kohm 1/10W	RM73B--512J	△R356	244 2043 937	Metal oxide film 10 ohm 1W (Non-burning type)	RS14B3A100JNBS(S)
R101-103	247 0009 985	Chip Resistor 10kohm 1/10W	RM73B--103J	R357	247 0008 915	Chip Resistor 2kohm 1/10W	RM73B--202J
R109	247 0011 902	Chip Resistor 33kohm 1/10W	RM73B--333J	R358	247 0013 984	Chip Resistor 470kohm 1/10W	RM73B--474J
R114	247 0005 976	Chip Resistor 200ohm 1/10W	RM73B--201J	R359	247 0009 956	Chip Resistor 7.5kohm 1/10W	RM73B--752J
R115	247 0003 949	Chip Resistor 22ohm 1/10W	RM73B--220J	R360	247 0009 985	Chip Resistor 10kohm 1/10W	RM73B--103J
R116	247 0012 956	Chip Resistor 130kohm 1/10W	RM73B--134J	R361	247 0010 987	Chip Resistor 27kohm 1/10W	RM73B--273J
				R362	247 0014 967	Chip Resistor 1Mohm 1/10W	RM73B--105J
				R363	247 0013 913	Chip Resistor 240kohm 1/10W	RM73B--244J
				R365-368	247 0014 967	Chip Resistor 1Mohm 1/10W	RM73B--105J

Ref. No.	Part No.	Part Name	Remarks	Ref. No.	Part No.	Part Name	Remarks	Q'ty
R406	247 0009 985	Chip Resistor 10kohm 1/10W	RM73B--103J	C405	257 0014 935	Ceramic(Chip) 0.1μF/25V	CK73F1E104Z	
R407	247 0014 967	Chip Resistor 1Mohm 1/10W	RM73B--105J	C406,407	254 4319 792	Electrolytic 4700μF/25V	CE04W1E472MC(ASF)	
R409	247 0005 989	Chip Resistor 220ohm 1/10W	RM73B--221J	C409	254 4367 906	Electrolytic 47μF/63V	CE04W1J470M(ASF)	
R411	247 0006 962	Chip Resistor 470ohm 1/10W	RM73B--471J	C413,414	254 4313 989	Electrolytic 33μF/50V	CE04W1H330M(ASF)	
R412	247 0009 914	Chip Resistor 5.1kohm 1/10W	RM73B--512J	C416	257 0003 988	Ceramic(Chip) 47pF/50V	CC73L1H470J	
R413	247 0006 962	Chip Resistor 470ohm 1/10W	RM73B--471J	C423	257 0014 935	Ceramic(Chip) 0.1μF/25V	CK73F1E104Z	
R415	247 0014 967	Chip Resistor 1Mohm 1/10W	RM73B--105J	C424	257 0009 966	Ceramic(Chip) 0.0047μF/50V	CK73B1H472K	
R416	247 0007 945	Chip Resistor 1kohm 1/10W	RM73B--102J	C425,426	257 0002 921	Ceramic(Chip) 10pF/50V	CC73L1H100D	
R420	247 0009 985	Chip Resistor 10kohm 1/10W	RM73B--103J	C427	256 1035 091	Ceramic 1μF/50V	CF93A1H105J	
R423,424	247 0009 985	Chip Resistor 10kohm 1/10W	RM73B--103J	C440,441	257 0014 935	Ceramic(Chip) 0.1μF/25V	CK73F1E104Z	
R431	247 0009 985	Chip Resistor 10kohm 1/10W	RM73B--103J	C442	257 0012 966	Ceramic(Chip) 0.01μF/50V	CK73F1H103Z	
R440,441	247 0009 985	Chip Resistor 10kohm 1/10W	RM73B--103J	C443--448	257 0014 935	Ceramic(Chip) 0.1μF/25V	CK73F1E104Z	
R442	247 0012 927	Chip Resistor 100kohm 1/10W	RM73B--104J	C463	257 0007 900	Ceramic(Chip) 0.001μF/50V	CC73L1H102J	
R443	247 0009 985	Chip Resistor 10kohm 1/10W	RM73B--103J	C475,476	253 9039 906	Ceramic 0.1μF/25V	CK45=1E104Z	
R445	247 0007 945	Chip Resistor 1kohm 1/10W	RM73B--102J					
R460--463	247 0007 945	Chip Resistor 1kohm 1/10W	RM73B--102J					
R483	247 0009 914	Chip Resistor 5.1kohm 1/10W	RM73B--512J					
R484	247 0005 905	Chip Resistor 100ohm 1/10W	RM73B--101J					
R705	247 0007 945	Chip Resistor 1kohm 1/10W	RM73B--102J					
△R491,492	244 2043 940	Metal Oxide 2.2kohm 1W	RS14B3A222JNBS(S)					
CAPACITORS GROUP				OTHER PARTS				Q'ty
C101	257 0014 935	Ceramic(Chip) 0.1μF/25V	CK73F1E104Z	X101	399 0165 007	Crystal Resonator	(16.9344MHz)	1
C103	254 4356 713	Electrolytic 100μF/50V	CE04W1H101MC(ARS)	X200	399 0165 007	Crystal Resonator	(16.9344MHz)	1
C105	257 0014 935	Ceramic(Chip) 0.1μF/25V	CK73F1E104Z	PT300	231 8063 009	:Pulse Trans		1
C106	254 4254 938	Electrolytic 47μF/16V	CE04W1C470M(SME)	Jk301,302	204 8178 028	1P Pin Jack		2
C107--109	257 0004 961	Ceramic(Chip) 100pF/50V	CC73L1H101J	△SW802	212 1118 002	Voltage Selector	Multi-Voltage only	1
C112	254 4254 925	Electrolytic 33μF/16V	CE04W1C330M(SME)	U304	269 0097 007	Optical Connector (IN)	(GP1F32R)	1
C119	257 0009 940	Ceramic(Chip) 0.0033μF/50V	CK73B1H332K	U305	269 0098 006	Optical Connector (OUT)	(GP1F32T)	1
C120	257 0014 935	Ceramic(Chip) 0.1μF/25V	CK73F1E104Z	CB101	205 0321 054	5P Connector Base (RED)		1
C121	257 0011 941	Ceramic(Chip) 0.022μF/25V	CK73B1E223K	CB102	205 0343 058	5P Connector Base (KR-PH)		1
C122	257 0005 944	Ceramic(Chip) 220pF/50V	CC73L1H221J	CB103	205 0892 004	12P FFC Connector Base (P=1)		1
C124	257 0006 969	Ceramic(Chip) 680pF/50V	CC73L1H681J	CB201	205 0736 063	35P FFC Connector Base		1
C125	257 0010 997	Ceramic(Chip) 0.056μF/50V	CK73B1H563K	CB202	205 0343 032	3P Connector Base (KR-PH)		1
C126	257 0007 942	Ceramic(Chip) 0.0015μF/50V	CC73L1H152J	CB401	205 0711 091	15P TBG Connector Base		1
C127	257 0005 944	Ceramic(Chip) 220pF/50V	CC73L1H221J	CB412	205 0233 087	8P EH Connector Base		1
C128	257 0011 909	Ceramic(Chip) 0.01μF/25V	CK73B1E103K	CB414,415	205 0653 036	3P VH Connector Base		2
C131	257 0011 909	Ceramic(Chip) 0.01μF/25V	CK73B1E103K	CB501	205 0233 087	8P EH Connector Base		1
C132,133	257 0002 921	Ceramic(Chip) 10pF/50V	CC73L1H100D	CB800	205 0581 001	2P VH Connector Base		1
C135	257 0009 937	Ceramic(Chip) 0.0027μF/50V	CK73B1H272K	CB803	205 0581 001	2P VH Connector Base		1
C141	254 4258 905	Electrolytic 4.7μF/35V	CE04W1V4R7M(SME)		204 2745 004	7P PH Connector Cord		1
C174	257 0014 935	Ceramic(Chip) 0.1μF/25V	CK73F1E104Z	TP102	205 0190 078	7P NH Connector Base		1
C204	257 0002 921	Ceramic(Chip) 10pF/50V	CC73L1H100D		417 0476 036	Radiator	for IC400, 403	2
C207	254 4260 948	Electrolytic 1μF/50V	CE04W1H010M(SME)		471 3304 015	Bind Screw 3x8		4
C301	257 0014 935	Ceramic(Chip) 0.1μF/25V	CK73F1E104Z		417 0476 010	Radiator	for IC401, 402	2
C350	257 0011 909	Ceramic(Chip) 0.01μF/25V	CK73B1E103K		412 2160 028	Common Plate		1
C351	257 0004 961	Ceramic(Chip) 100pF/50V	CC73L1H101J		461 0415 007	Rubber Sheet		3
C352--354	257 0014 935	Ceramic(Chip) 0.1μF/25V	CK73F1E104Z		415 0366 043	UL Tube (φ2) Clear		1
C401,402	254 4356 771	Electrolytic 3300μF/50V	CE04W1H332MC(ARS)		461 0767 001	Rubber Sheet		1
C403,404	254 4313 989	Electrolytic 33μF/50V	CE04W1H330M(ASF)					

1U-2797M DIGITAL SERVO UNIT ASS'Y (DCD-S10 Asia model only)

Ref. No.	Part No.	Part Name	Remarks	Ref. No.	Part No.	Part Name	Remarks
SEMICONDUCTORS GROUP							
IC101	262 1879 003	IC CXD2515Q		R122	247 0009 956	Chip Resistor 7.5kohm 1/10W	RM73B--752J
IC102	263 0909 906	IC BA6392FP		R123	247 0008 999	Chip Resistor 4.3kohm 1/10W	RM73B--432J
IC103	263 0565 007	IC BA15218		R124	247 0005 989	Chip Resistor 220ohm 1/10W	RM73B--221K
IC104	262 0910 002	IC YM3623B		R126	247 0018 905	Chip Resistor 0ohm 1/10W	RM73B--0R0K
IC105	263 0565 007	IC BA15218		R127	247 0011 915	Chip Resistor 36kohm 1/10W	RM73B--363J
IC110,111	262 1641 901	IC HD74HC157FP		R128	247 0008 960	Chip Resistor 3.3kohm 1/10W	RM73B--332J
IC201	262 2111 003	IC M38173M6-292FP		R129	247 0007 974	Chip Resistor 1.3kohm 1/10W	RM73B--132J
IC202	262 1265 002	IC TC74HCU04AP		R130	247 0014 967	Chip Resistor 1Mohm 1/10W	RM73B--105J
IC300	262 1869 000	IC SM5845AF		R131	247 0012 927	Chip Resistor 100kohm 1/10W	RM73B--104J
IC350	263 0615 902	IC BA15218F		R132	247 0009 998	Chip Resistor 11kohm 1/10W	RM73B--113J
IC400	263 0516 001	IC NJM7812FA	Regulator +12V	R133	247 0008 960	Chip Resistor 3.3kohm 1/10W	RM73B--332J
IC401	263 0539 004	IC NJM79M12FA	Regulator -12V	R135	247 0008 960	Chip Resistor 3.3kohm 1/10W	RM73B--332J
IC402	263 0793 002	IC NJM7806FA(S)	Regulator +6V	R136	247 0007 945	Chip Resistor 1kohm 1/10W	RM73B--102J
IC403	263 0809 006	IC NJM7805FA(S)	Regulator +5V	R138	247 0009 998	Chip Resistor 11kohm 1/10W	RM73B--113J
IC406,407	268 0074 904	IC Protector ICP-N20		R144,145	247 0012 943	Chip Resistor 120kohm 1/10W	RM73B--124J
IC409	263 0652 907	IC PST529C		R146	247 0005 989	Chip Resistor 220ohm 1/10W	RM73B--221J
TR101	274 0036 905	Transistor 2SD468(C)		R147	247 0010 929	Chip Resistor 15kohm 1/10W	RM73B--153J
TR102	272 0025 907	Transistor 2SB562(C)		R148	247 0010 916	Chip Resistor 13kohm 1/10W	RM73B--133J
TR103	269 0026 900	Transistor RN2202(10K-10K)	Built in Resistor	△R149	244 2051 945	Metal oxide film 1 ohm 1W (Non-burning type)	RS14B3A010JNBS(S)
TR111	274 0036 905	Transistor 2SD468(C)		R151	247 0009 956	Chip Resistor 7.5kohm 1/10W	RM73B--752J
TR112	272 0025 907	Transistor 2SB562(C)		R161	247 0012 985	Chip Resistor 180kohm 1/10W	RM73B--184J
TR119	272 0025 907	Transistor 2SB562(C)		R162	247 0011 999	Chip Resistor 75kohm 1/10W	RM73B--753J
TR120	274 0036 905	Transistor 2SD468(C)		R192	247 0003 949	Chip Resistor 220ohm 1/10W	RM73B--220J
TR350	273 0303 910	Transistor 2SC1740S(S)		R202	247 0007 945	Chip Resistor 1kohm 1/10W	RM73B--102J
TR401	272 0025 907	Transistor 2SB562(C)		R206,207	247 0007 945	Chip Resistor 1kohm 1/10W	RM73B--102J
TR402,403	269 0025 901	Transistor RN1202(10K-10K)	Built in Resistor	R209	247 0004 977	Chip Resistor 75ohm 1/10W	RM73B--750J
D101,102	276 0432 903	Diode 1SS270A		R214,215	247 0012 943	Chip Resistor 120kohm 1/10W	RM73B--124J
D107	276 0432 903	Diode 1SS270A		R216	247 0012 927	Chip Resistor 100kohm 1/10W	RM73B--104J
D203	276 0432 903	Diode 1SS270A		R217	247 0005 989	Chip Resistor 220ohm 1/10W	RM73B--221J
D402,403	276 0553 905	Diode 1SR35-200A		R218	247 0004 922	Chip Resistor 47ohm 1/10W	RM73B--470J
D404	276 0466 908	Zener Diode HZS7C-1	7V	R219	247 0012 927	Chip Resistor 100kohm 1/10W	RM73B--104J
D405	276 0484 906	Zener Diode HZS33-1	33V	R225	247 0004 977	Chip Resistor 75ohm 1/10W	RM73B--750J
D410-421	276 0553 905	Diode 1SR35-200A		R300-302	247 0007 945	Chip Resistor 1kohm 1/10W	RM73B--102J
RESISTORS GROUP (Not included Carbon Film ±5% 1/4W)				R350-355	247 0009 985	Chip Resistor 10kohm 1/10W	RM73B--103J
R001,002	247 0018 905	Chip Resistor 0ohm 1/10W	RM73B--0R0K	△R356	244 2043 937	Metal oxide film 10 ohm 1W (Non-burning type)	RS14B3A100JNBS(S)
R003,004	247 0009 914	Chip Resistor 5.1kohm 1/10W	RM73B--512J	R357	247 0008 915	Chip Resistor 2kohm 1/10W	RM73B--202J
R005,006	247 0018 905	Chip Resistor 0ohm 1/10W	RM73B--0R0K	R358	247 0013 984	Chip Resistor 470kohm 1/10W	RM73B--474J
R007	247 0009 914	Chip Resistor 5.1kohm 1/10W	RM73B--512J	R359	247 0009 956	Chip Resistor 7.5kohm 1/10W	RM73B--752J
R101-103	247 0009 985	Chip Resistor 10kohm 1/10W	RM73B--103J	R360	247 0009 985	Chip Resistor 10kohm 1/10W	RM73B--103J
R109	247 0011 902	Chip Resistor 33kohm 1/10W	RM73B--333J	R361	247 0010 987	Chip Resistor 27kohm 1/10W	RM73B--273J
R114	247 0005 976	Chip Resistor 200ohm 1/10W	RM73B--201J	R362	247 0014 967	Chip Resistor 1Mohm 1/10W	RM73B--105J
R115	247 0003 949	Chip Resistor 22ohm 1/10W	RM73B--220J	R363	247 0013 913	Chip Resistor 240Kohm 1/10W	RM73B--244J
R116	247 0012 956	Chip Resistor 130kohm 1/10W	RM73B--134J	R365-368	247 0014 967	Chip Resistor 1Mohm 1/10W	RM73B--105J
R118	247 0009 901	Chip Resistor 4.7kohm 1/10W	RM73B--472J	R406	247 0009 985	Chip Resistor 10kohm 1/10W	RM73B--103J
R120	247 0009 901	Chip Resistor 4.7kohm 1/10W	RM73B--472J	R407	247 0014 967	Chip Resistor 1Mohm 1/10W	RM73B--105J
R121	247 0011 944	Chip Resistor 47kohm 1/10W	RM73B--473J	R409	247 0005 989	Chip Resistor 220ohm 1/10W	RM73B--221J
				R411	247 0006 962	Chip Resistor 470ohm 1/10W	RM73B--471J
				R412	247 0009 914	Chip Resistor 5.1kohm 1/10W	RM73B--512J
				R413	247 0006 962	Chip Resistor 470ohm 1/10W	RM73B--471J

Ref. No.	Part No.	Part Name	Remarks	Ref. No.	Part No.	Part Name	Remarks	Q'ty
R415	247 0014 967	Chip Resistor 1Mohm 1/10W	RM73B--105J	C423	257 0014 935	Ceramic(Chip) 0.1μF/25V	CK73F1E104Z	
R416	247 0007 945	Chip Resistor 1kohm 1/10W	RM73B--102J	C424	257 0009 966	Ceramic(Chip) 0.0047μF/50V	CK73B1H472K	
R420	247 0009 985	Chip Resistor 10kohm 1/10W	RM73B--103J	C425,426	257 0002 921	Ceramic(Chip) 10pF/50V	CC73L1H100D	
R423,424	247 0009 985	Chip Resistor 10kohm 1/10W	RM73B--103J	C427	256 1035 091	Ceramic 1μF/50V	CF93A1H105J	
R431	247 0009 985	Chip Resistor 10kohm 1/10W	RM73B--103J	C431,432	254 4446 720	Electrolytic 2.2μF/50V	CE04W1H2R2MC(ARSAG)	
R440,441	247 0009 985	Chip Resistor 10kohm 1/10W	RM73B--103J	C440	257 0014 935	Ceramic(Chip) 0.1μF/25V	CK73F1E104Z	
R442	247 0012 927	Chip Resistor 100kohm 1/10W	RM73B--104J	C441,442	255 6167 000	Polystyrol 0.01μF/125V	CQ09S2B103K(B)	
R443	247 0009 985	Chip Resistor 10kohm 1/10W	RM73B--103J	C443-448	257 0014 935	Ceramic(Chip) 0.1μF/25V	CK73F1E104Z	
R445	247 0007 945	Chip Resistor 1kohm 1/10W	RM73B--102J	C463	257 0007 900	Ceramic(Chip) 0.001μF/50V	CC73L1H102J	
R460-463	247 0007 945	Chip Resistor 1kohm 1/10W	RM73B--102J	C491	255 4235 934	Film 0.01μF/100V	CQ93P2A103J(NH)	
R483	247 0009 914	Chip Resistor 5.1kohm 1/10W	RM73B--512J	OTHER PARTS				
R484	247 0005 905	Chip Resistor 100ohm 1/10W	RM73B--101J	X101	399 0165 007	Crystal Resonator	(16.9344MHz)	1
R705	247 0007 945	Chip Resistor 1kohm 1/10W	RM73B--102J	X200	399 0165 007	Crystal Resonator	(16.9344MHz)	1
△R491,492	244 2043 940	Metal Oxide 2.2kohm 1W	RS14B3A222JNBS(S)	PT300	231 8063 009	:Pulse Trans		1
CAPACITORS GROUP				Jk301,302	204 8178 028	1P Pin Jack		2
C101	257 0014 935	Ceramic(Chip) 0.1μF/25V	CK73F1E104Z	U304	269 0097 007	Optical Connector (IN)	(GP1F32R)	1
C103	254 4486 706	Electrolytic 1000μF/6.3V	CE04W0J102MC(ARD)	U305	269 0098 006	Optical Connector (OUT)	(GP1F32T)	1
C105	257 0014 935	Ceramic(Chip) 0.1μF/25V	CK73F1E104Z	CB101	205 0321 054	5P Connector Base (RED)		1
C106	254 4254 938	Electrolytic 47μF/16V	CE04W1C470M(SME)	CB102	205 0343 058	5P Connector Base (KR-PH)		1
C107-109	257 0004 961	Ceramic(Chip) 100pF/50V	CC73L1H101J	CB103	205 0892 004	12P FFC Connector Base (P=)		1
C112	254 4254 925	Electrolytic 33μF/16V	CE04W1C330M(SME)	CB201	205 0736 063	35P FFC Connector Base		1
C119	257 0009 940	Ceramic(Chip) 0.0033μF/50V	CK73B1H332K	CB202	205 0343 032	3P Connector Base (KR-PH)		1
C120	257 0014 935	Ceramic(Chip) 0.1μF/25V	CK73F1E104Z	CB401	205 0711 091	15P TBG Connector Base		1
C121	257 0011 941	Ceramic(Chip) 0.022μF/25V	CK73B1E223K	CB410	205 0190 036	3PNH Connector Base		1
C122	257 0005 944	Ceramic(Chip) 220pF/50V	CC73L1H221J	CB411	205 0190 005	6P NH Connector Base		1
C124	257 0006 969	Ceramic(Chip) 680pF/50V	CC73L1H681J	CB412	205 0233 087	8P EH Connector Base		1
C125	257 0010 997	Ceramic(Chip) 0.056μF/50V	CK73B1H563K	CB414,415	205 0653 036	3P VH Connector Base		2
C126	257 0007 942	Ceramic(Chip) 0.0015μF/50V	CC73L1H152J	CB501	205 0233 087	8P EH Connector Base		1
C127	257 0005 944	Ceramic(Chip) 220pF/50V	CC73L1H221J	CB800	205 0606 025	2P Wrapping Terminal		1
C128	257 0011 909	Ceramic(Chip) 0.01μF/25V	CK73B1E103K	CB801,802	205 0581 001	2P VH Connector Base		2
C131	257 0011 909	Ceramic(Chip) 0.01μF/25V	CK73B1E103K	CB803	205 0581 001	2P VH Connector Base		1
C132,133	257 0002 921	Ceramic(Chip) 10pF/50V	CC73L1H100D		204 2745 004	7P PH Connector Cord		1
C135	257 0009 937	Ceramic(Chip) 0.0027μF/50V	CK73B1H272K	TP102	205 0190 078	7P NH Connector Base		1
C141	254 4258 905	Electrolytic 4.7μF/35V	CE04W1V4R7M(SME)		417 0476 010	Radiator	for IC400,403	2
C174	257 0014 935	Ceramic(Chip) 0.1μF/25V	CK73F1E104Z		471 3304 015	Bind Screw 3x8		4
C204	257 0002 921	Ceramic(Chip) 10pF/50V	CC73L1H100D		417 0476 036	Radiator	for IC401,402	2
C207	254 4260 948	Electrolytic 1μF/50V	CE04W1H010M(SME)		412 2160 031	Common Plate (CU 0.8)		1
C301	257 0014 935	Ceramic(Chip) 0.1μF/25V	CK73F1E104Z		461 0415 007	Rubber Sheet		5
C350	257 0011 909	Ceramic(Chip) 0.01μF/25V	CK73B1E103K		415 0366 043	UL TUBE (φ2) Clear		1
C351	257 0004 961	Ceramic(Chip) 100pF/50V	CC73L1H101J		461 0767 001	Rubber Sheet		1
C352-354	257 0014 935	Ceramic(Chip) 0.1μF/25V	CK73F1E104Z					
C401,402	254 4356 771	Electrolytic 3300μF/50V	CE04W1H332MC(ARS)					
C403,404	254 4356 742	Electrolytic 470μF/50V	CE04W1H471(ARS)					
C405	257 0014 935	Ceramic(Chip) 0.1μF/25V	CK73F1E104Z					
C406,407	254 4319 792	Electrolytic 4700μF/25V	CE04W1E472MC(ASF)					
C409	254 4367 906	Electrolytic 47μF/63V	CE04W1J470M(ASF)					
C413,414	254 4313 989	Electrolytic 33μF/50V	CE04W1H330M(ASF)					
C416	257 0003 988	Ceramic(Chip) 47pF/50V	CC73L1H470J					
C420,421	256 1054 001	Metalized 0.1μF/50V	CF93B1H105K(GSG)					

1U-2796 AUDIO UNIT ASS'Y
(1U-2796: DCD-3000 Europe, U.S.A. & Canada and Multi-Voltage Models)
(1U-2796A: DCD-S10 Europe, U.S.A. & Canada models)
(1U-2796M: DCD-S10 Asia Model.)

Ref. No.	Part No.	Part Name	Remarks
SEMICONDUCTORS GROUP			
IC301-304	262 1837 016	IC :PCM1702P-J	
IC309,310	263 0565 007	IC BA15218	
IC309,310	263 0990 009	:IC OP275GP	Asia model only
IC311-318	262 0864 006	IC μ PC4570C	
IC311,312	263 0836 008	IC SSM2139	Asia model only
IC313, 314	263 0360 008	:ICNE5532	Asia model only
IC315-318	263 0205 008	IC NJM2041DD	Asia model only
IC355,356	263 0432 907	IC NJM78L05A	Regulator +5V
IC357,358	263 0722 905	IC NJM79L05A	Regulator -5V
IC501	263 0995 004	IC NJM4556AD	
IC801	499 0264 004	Remote Sensor GP1U571	
IC901,902	263 0565 007	IC BA15218	
TR351	269 0026 900	Transistor RN2202 (10K-10K)	Built in Resistor
TR352	269 0025 901	Transistor RN1202 (10K-10K)	Built in Resistor
TR353	269 0026 900	Transistor RN2202 (10K-10K)	Built in Resistor
TR500,501	273 0253 918	Transistor 2SC2878 (A/B)	
TR801,802	269 0025 901	Transistor RN1202 (10K-10K)	Built in Resistor
TR804	269 0025 901	Transistor RN1202 (10K-10K)	Built in Resistor
TR901-908	273 0253 918	Transistor 2SC2878 (A/B)	
D351-354	276 0432 903	Diode 1SS270A	
D805-807	276 0432 903	Diode 1SS270A	
D818,819	276 0432 903	Diode 1SS270A	
LD801,802	393 9416 908	LED SEL-2810R	
LD804	393 9419 905	LED SEL-2810D	
RESISTORS GROUP (All carbon film resistor is DCD-S10 Asia model only.)			
R335,336	241 2471 962	Carbon Film 10ohm 1/4W	RD14B2E100J(PSNB)
R337,338	241 2427 923	Carbon Film 100kohm 1/4W	RD14B2E104J(PSNB)
R351	241 2424 984	Carbon Film 10kohm 1/4W	RD14B2E103J(PSNB)
R353	241 2423 956	Carbon Film 3kohm 1/4W	RD14B2E302J(PSNB)
R354	241 2419 999	Carbon Film 91ohm 1/4W	RD14B2E910J(PSNB)
R355	241 2422 944	Carbon Film 1kohm 1/4W	RD14B2E102J(PSNB)
R361-364	241 2421 929	Carbon Film 330ohm 1/4W	RD14B2E331J(PSNB)
R365-372	241 2422 944	Carbon Film 1kohm 1/4W	RD14B2E102J(PSNB)
R373-376	241 2423 972	Carbon Film 3.6kohm 1/4W	RD14B2E362J(PSNB)
R377-380	241 2423 927	Carbon Film 2.2kohm 1/4W	RD14B2E222J(PSNB)
R381,382	241 2424 942	Carbon Film 6.8kohm 1/4W	RD14B2E682J(PSNB)
R383,384	241 2423 972	Carbon Film 3.6kohm 1/4W	RD14B2E362J(PSNB)
R385,386	241 2422 973	Carbon Film 1.3kohm 1/4W	RD14B2E132J(PSNB)
R387,388	241 2423 943	Carbon Film 2.7kohm 1/4W	RD14B2E272J(PSNB)
R389-392	241 2424 900	Carbon Film 4.7kohm 1/4W	RD14B2E472J(PSNB)
R811-814	241 2424 942	Carbon Film 6.8kohm 1/4W	RD14B2E682J(PSNB)
R815	241 2418 945	Carbon Film 22ohm 1/4W	RD14B2E220J(PSNB)
R816	241 2415 919	Carbon Film 47ohm 1/4W	RD14B2E470J(PSNB)
R998,999	241 2427 923	Carbon Film 100kohm 1/4W	RD14B2E104J(PSNB)
VR300	211 0544 111	Variable Resistor 20Kohm	V1620V20FA203M

Ref. No.	Part No.	Part Name	Remarks
CAPACITORS GROUP			
C057	253 9039 906	Ceramic 0.1 μ F/25V	CK45-1E104Z
C321-324	254 4356 027	Electrolytic 22 μ F/50V	CE04W1H220M(ARS)
C325-332	254 4313 918	Electrolytic 10 μ F/50V	CE04W1H100M(ASF)
C333-340	254 4356 713	Electrolytic 100 μ F/50V	CE04W1H101MC(ARS)
C343-346	254 4356 742	Electrolytic 470 μ F/50V	CE04W1H471(ARS)
C347-350	254 4347 052	Electrolytic 2.2 μ F/50V	CE04W1H2R2M(ARSA)
C351	254 4256 952	Electrolytic 220 μ F/25V	CE04W1E221M(SME)
C351	254 4488 704	Electrolytic 220 μ F/25V	CE04W1E221MC(ARD)
			DCD-S10 Asia only
C353-356	255 4235 921	Film 270pF/100V	CQ93P2A271J(NH)
C353-356	255 6175 047	Polystyrol 270pF/125V	CQ09S2B271KF(B)
			DCD-S10 Asia only
C357-360	255 4235 918	Film 100pF/100V	CQ93P2A101J(NH)
C357-360	255 6175 034	Polystyrol 100pF/125V	CQ09S2B101KF(B)
			DCD-S10 Asia only
C371,372	255 4232 911	Film 180pF/100V	CQ93P2A181J(NH)
C371,372	255 6175 018	Polystyrol 80pF/125V	CQ09S2B181KF(B)
			DCD-S10 Asia only
C373,374	255 4232 908	Film 820pF/100V	CQ93P2A821J(NH)
C373,374	255 6175 021	Polystyrol 820pF/125V	CQ09S2B821KF(B)
			DCD-S10 Asia only
C375-380	255 4237 903	Film 0.0027 μ F/100V	CQ93P2A102J(NH)
C375,380	255 6175 005	Polystyrol 0.0027 μ F/125V	CQ09S2B272KF(B)
			DCD-S10 Asia only
C381-388	254 4356 713	Electrolytic 100 μ F/50V	CE04W1H101MC(ARS)
C389,390	255 6167 000	Polystyrol 0.01 μ F/125V	CQ09S2B103K(B)
			DCD-S10 Asia only
C391,392	256 1045 007	Metallized 1 μ F/63V	CF93B1J105K(SA)
			(DCD-S10 only)
C503	254 4254 776	Electrolytic 470 μ F/16V	CE04W1C471MC(SME)
C503	254 4487 705	Electrolytic 470 μ F/16V	CE04W1C471MC(ARD)
			(DCD-S10 Asia only)
C504	254 4254 792	Electrolytic 2200 μ F/16V	CE04W1C222MC(SME)
C504	254 4452 714	Electrolytic 2200 μ F/16V	CE04W1C222MC(ASF)
			(DCD-S10 Asia only)
C807	253 9036 909	Ceramic 0.1 μ F/25V	CK45-1E104Z
Δ C900	253 8014 003	Ceramic 0.01 μ F/400VAC	CK45F2GAC103M
C901-904	254 4356 739	Electrolytic 47 μ F/50V	CE04W1H470MC(ARS)
C905-908	255 4232 924	Film 39pF/100V	CQ93P2A390J(NH)
C909-912	255 4232 937	Film 0.001 μ F/100V	CQ93P2A102J(NH)
OTHER PARTS			
RL301	214 0127 003	Relay (RY-12W)	1
Δ SW900	212 1101 006	Power Switch (TV-5)	1
	212 5604 907	Tact Switch	7
JK403,404	204 8406 017	1P Pin Jack	DCD-S10 Asia only 2

1U-2836A SERVO AMP UNIT ASS'Y
(This unit is common in all models and
Ser. No. 501 ** * and after.)**

Ref. No.	Part No.	Part Name	Remarks	Q'ty	Ref. No.	Part No.	Part Name	Remarks	Q'ty
JK405	204 8265 009	4P RCA Pin Jack (EMI)	Except DCD-S10 Asia	1	SEMICONDUCTORS GROUP				
PJ301	204 8322 007	Head Phone Jack		1	IC901	263 0565 007	IC BA15218	Built in resistor	
FL801	393 4095 007	FL Tube	(FIP10SM6)	1	TR901	269 0025 901	Transistor RN1202		
CB301	204 2447 014	8P PH-SAN Shield Cord		1	RESISTORS GROUP (Not included Carbon Film $\pm 5\%$ 1/4W type. Refer to the Schematic diagram for those parts.)				
CB400	205 0711 091	15P TBG Connector Base		1	CAPACITORS GROUP				
CB401,402	205 0581 001	2P VH Connector Base	DCD-S10 Asia only	2	C901	253 2293 934	Ceramic Cap. 100pF/50V	CK45B1H101K	
CB404,405	205 0653 036	3P VH Connector Base		2	C902	256 1035 907	Metalized Cap. 0.18 μ F/50V	CF93A1H184J	
CB406	205 0343 061	6P Connector Base (KR-PH)		1	OTHER GROUP				
CB805	205 0736 063	35P FFC Connector Base		1		—	(P.W. board)		(1)
CB900	205 0581 001	2P VH Connector Base		1	CB901	205 0343 074	7P Conn. Base (KR-PH)		1
CC301	205 0343 087	8P Connector Base (KR-PH)		1		001 0018 082	Vinyl Wire	L=40	1
CC302	203 4650 039	3P PH-SAN Connector Cord		1		001 0164 020	Vinyl Wire	L=140	1
CN901	205 0343 061	6P Connector Base (KR-PH)		1					
CN902,903	205 0428 009	3P Cannon Connector		2					
	415 0299 000	Condenser Cover	for C900	1					

IC TERMINAL FUNCTION

CXD2515Q (IC101)

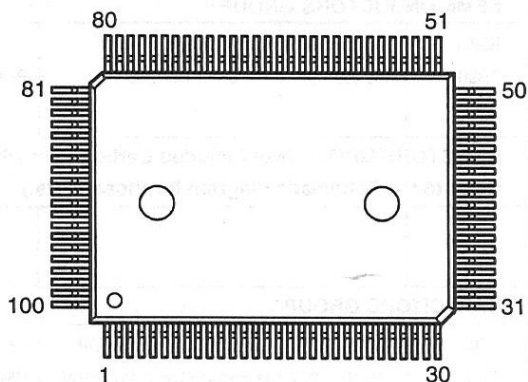

CXD2515Q Terminal Function

Pin No.	Symbol	I/O	Terminal Function
1	SRON	O	Sled drive output.
2	SRDR	O	Sled drive output.
3	SFON	O	Sled drive output.
4	TFDR	O	Tracking drive output.
5	TRON	O	Tracking drive output.
6	TRDR	O	Tracking drive output.
7	TFON	O	Tracking drive output.
8	FFDR	O	Focus drive output.
9	FRON	O	Focus drive output.
10	FRDR	O	Focus drive output.
11	FFON	O	Focus drive output.
12	VCOO	O	Oscillation circuit output for analog EFM PLL.
13	VCOI	I	Oscillation circuit input for analog EFM PLL. fLOCK=8.6436MHz.
14	TEST	I	Test terminal, normally GND.
15	V _{SS}	—	Digital GND.
16	TES2	I	Test terminal, normally GND.
17	TES3	I	Test terminal, normally GND.
18	PDO	O	Charge pump output for analog EFM PLL.
19	VPCO	O	PLL charge pump output for variable pitch.
20	VCKI	I	Clock input from external VCO for variable pitch. fCENTER=16.9344MHz.
21	AV _{DD}	—	Analog power supply.
22	IGEN	I	Current source reference resistor connecting terminal for OP amplifier.
23	AV _{SS}	—	Analog GND.
24	ADII	I	A/D converter input terminal.
25	ADIO	O	OP amplifier output terminal.
26	RFDC	I	RF signal input. Input range 2.15~5.0V (at V _{DD} =AV _{DD} =5.0V).
27	TE	I	Tracking error signal input. Input range 2.5V±1.0V (at V _{DD} =AV _{DD} =5.0V).
28	SE	I	Sled error signal input. Input range 2.5V±1.0V (at V _{DD} =AV _{DD} =5.0V).
29	FE	I	Focus error signal input. Input range 2.5V±1.0V (at V _{DD} =AV _{DD} =5.0V).
30	VC	I	Mid-point voltage input terminal.
31	FIL0	O	Filter output for master PLL.
32	FIL1	I	Filter input for master PLL.
33	PCO	O	Charge pump output for master PLL.
34	CLTV	I	VCO control voltage input for master.
35	AV _{SS}	—	Analog GND.
36	RFAC	I	EFM signal input.
37	BIAS	I	Asymmetry circuit constant current input.
38	ASYI	I	Asymmetry compare voltage input.
39	ASYO	O	EFM full swing output. (L=V _{SS} , H=V _{DD}).
40	AV _{DD}	—	Analog power supply.

Pin No.	Symbol	I/O	Terminal Function
41	V _{DD}	—	Digital power supply.
42	ASYE	I	Asymmetry circuit ON/OFF (L=OFF, H=ON).
43	PSSL	I	Audio data output mode shifting input. L to serial output, H to parallel output.
44	WDCK	O	48-bit slot D/A interface. Word clock f=2Fs.
45	LRCK	O	48-bit slot D/A interface. LR clock f=Fs.
46	DA16	O	DA16 output at PSSL=1. Serial data of 48-bit slot at PSSL=0.
47	DA15	O	DA15 output at PSSL=1. Bit clock of 48-bit slot at PSSL=0.
48	DA14	O	DA14 output at PSSL=1. Serial data of 64-bit slot at PSSL=0.
49	DA13	O	DA13 output at PSSL=1. Bit clock of 64-bit slot at PSSL=0.
50	DA12	O	DA12 output at PSSL=1. LR clock of 64-bit slot at PSSL=0.
51	DA11	O	DA11 output at PSSL=1. G _{TOP} output at PSSL=0.
52	DA10	O	DA10 output at PSSL=1. XUGF output at PSSL=0.
53	DA09	O	DA09 output at PSSL=1. XPLCK output at PSSL=0.
54	DA08	O	DA08 output at PSSL=1. GFS output at PSSL=0.
55	DA07	O	DA07 output at PSSL=1. RFCK output at PSSL=0.
56	DA06	O	DA06 output at PSSL=1. C2PO output at PSSL=0.
57	DA05	O	DA05 output at PSSL=1. XRAOF output at PSSL=0.
58	DA04	O	DA04 output at PSSL=1. MNT3 output at PSSL=0.
59	DA03	O	DA03 output at PSSL=1. MNT2 output at PSSL=0.
60	DA02	O	DA02 output at PSSL=1. MNT1 output at PSSL=0.
61	DA01	O	DA01 output at PSSL=1. MNT0 output at PSSL=0.
62	XTAI	I	X'tal oscillation circuit input. 16.9344MHz or 33.8688MHz input.
63	XTAO	O	X'tal oscillation circuit output.
64	XTSL	I	X'tal selection input terminal. L at X'tal for 16.9344MHz, at 33.8688MHz turns to H.
65	V _{SS}	—	Digital GND.
66	FSTI	I	2/3 divided input of terminals 62 and 63.
67	FSTO	O	2/3 divided input of terminals 62 and 63. Unvarying by variable pitch.
68	C4M	O	4.2366MHz output. Simultaneously varies when variable pitched.
69	C16M	O	16.9344MHz output. Simultaneously varies when variable pitched.
70	MD2	I	Digital-out ON/OFF control terminal (L=OFF, H=ON).
71	DOUT	O	Digital-out output terminal.
72	EMPH	O	Emphasis mode output of playback disc (L at without emphasis, H at emphasized).
73	WFCK	O	WFCK output.
74	SCOR	O	Subcode sync output terminal (H at detecting either one of SO or SI subcode sync).
75	SBSO	O	Serial output of sub P-W.
76	EXCK	I	Clock input for SBSO read out.
77	SQSO	O	SubQ 80-bit output. PCM peak data, level data 16-bit output.
78	SQCK	I	Clock input for SQSO read out.
79	MUTE	I	Mute shifting terminal (H to mute).
80	SENS	O	SENS output. Outputs to CPU.
81	XRST	I	System reset (L to reset).
82	DIRC	I	Used for at I-track jump.
83	SCLK	I	Clock for SENS serial data reading.
84	DFSW	I	DFCT shifting terminal (H to DFCT countermeasure circuit OFF).
85	ATSK	I	Anti-shock terminal.
86	DATA	I	Serial data input from CPU.
87	XLAT	I	Latch input from CPU.
88	CLOK	I	Serial data transfer clock input from CPU.
89	COUT	O	Number of track count signal output.
90	V _{DD}	—	Digital power supply.
91	MIRR	O	Mirror signal output.
92	DFCT	O	Defect signal output.
93	FOK	O	Focus OK output.
94	FSW	O	Output filter shifting output of spindle motor.
95	MON	O	ON/OFF control output of spindle motor.
96	MDP	O	Servo control of spindle motor.
97	MDS	O	Servo control of spindle motor.
98	LOCK	O	Sampling GFS with 460Hz and outputs H at GFS is H. Outputs L when continuously 8 times L.
99	SSTP	I	Terminal for inner most circle detection signal of disc.
100	SFDR	O	Sled drive output.

M38173M6-292FP (IC201)

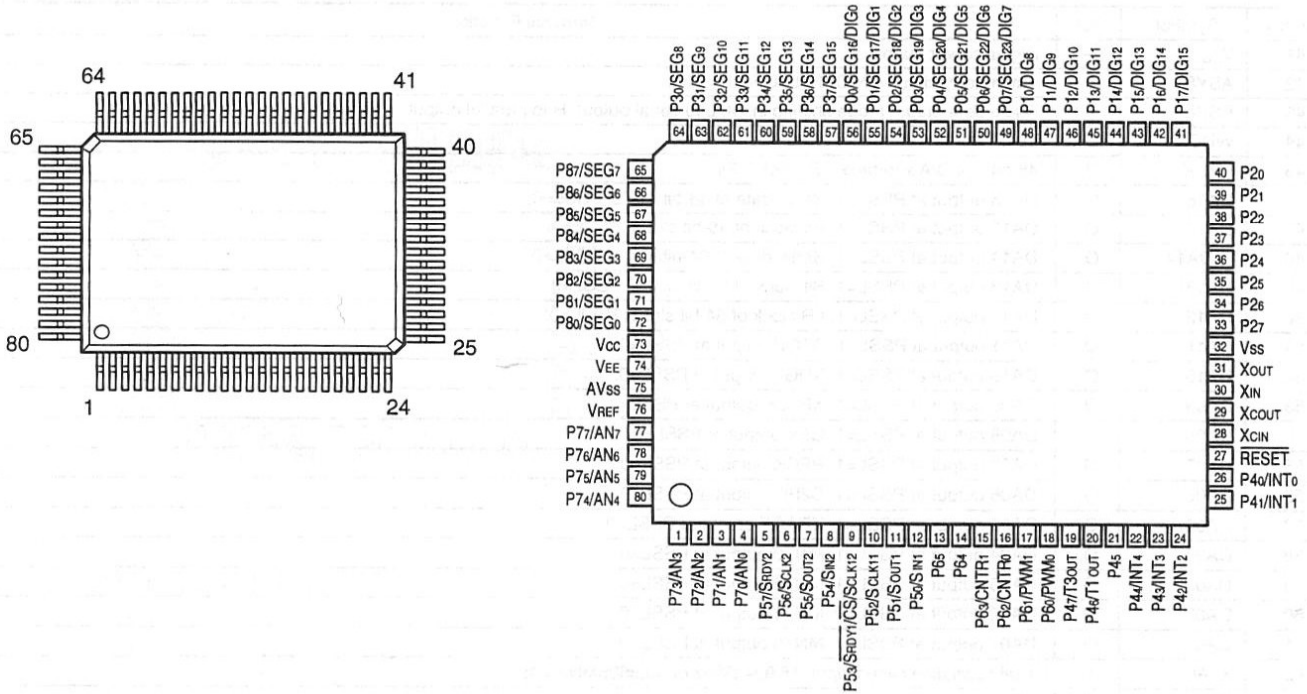

M38173M6-292FP Terminal Function

Pin No.	Terminal Name	Symbol	I/O	TY	OP	AC	IN	Terminal Function
1	P73	DMUTE	O	A	—	H	H	Digital mute signal (H: ON, L: OFF).
2	P72	AMUTE	O	A	—	H	H	Analog mute signal (H: ON, L: OFF).
3	P71	VRUP	O	A	—	L	H	Electrical-drive variable resistor up output.
4	P70	VRDN	O	A	—	L	H	Electrical-drive variable resistor down output.
5	P57	INVERT	O	B	—	L	H	Audio inverting output (L; negative, H; positive)
6	P56	FDATA	O	B	—	—	H	Data for NPC SM5845 control.
7	P55	FCLK	O	B	—	—	H	Clock for NPC SM5845 control.
8	P54	FLAT	O	B	—	L	H	Latch for NPC SM5845 control.
9	P53	INMOST	I	B	—	L	(H)	INMOST SW inner circle detection switch.
10	P52	SQCK	O	B	—	—	H	SUB code Q data reading clock.
11	P51	MODEL	I	B	—	—	H	H: DCD 3000, L: DCD1015
12	P50	SUBQ	I	B	—	H	(H)	SUB code Q data input.
13	P65	DIRC	O	A	—	L	H	DIRC output (CXA1372).
14	P64	FOK	I	A	—	H	(H)	FOK input (CXA1372).
15	P63	GFS	I	A	—	H	(H)	GFS input (CXA1372)
16	P62	SENSE	I	A	—	H	(H)	Sense input (CXA1372, CXA2515).
17	P61	CLK	O	A	—	—	H	Control clock output (CXA1372, CXD2515).
18	P60	DATA	O	A	—	—	H	Control data output (CXA1372, CXD2515).
19	P47	XLT	O	A	—	L	H	Control latch output (CXA1372, CXD2515).
20	P46	LASW	O	A	—	H	L	Laser drive signal.
21	P45	SCLK	O	A	—	—	L	SUB setting value read clock output.
22	P44	STEP	O	A	—	—	—	Electron variable resistor gain setting clock output.
23	P43	E. VR. UP	—	A	—	—	H	Electron variable resistor up output.
24	P42	E. VR. DOWN	O	A	—	—	H	Electron variable resistor down output.
25	P41/INT1	SCOR	I	A	—	L	(H)	Interrupt from SUB code.

IO: I/O Type: A: Standard
 TY: Type B: N-ch Open drain
 OP: Option C: P-ch Open drain (high voltage proof)
 AC: Action
 IN: Initialize

Pin No.	Terminal Name	Symbol	I/O	TY	OP	AC	IN	Terminal Function
26	P40/INT0	RIN	I	A	—	L	(H)	Interrupt from remote control.
27	RESET	RST	I	—	—	L	—	Reset signal input.
28	XCIN	LRCK	I	—	—	—	—	SUB clock input for LRCK.
29	XCOUT	NC	O	—	—	—	—	Open.
30	XIN	XIN	I	—	—	—	—	XTAL 4.23 MHz.
31	XOUT	XOUT	O	—	—	—	—	XTAL 4.23 MHz.
32	VSS	GND	I	—	—	—	—	GND
33	P27	MAINS	O	A	—	H	H	Alpha 1 ON/OFF H: ON, L: OFF.
34	P26	SHFTN	O	A	—	L	H	Bit shift ON/OFF H: OFF, L: ON.
35	P25	ADEEN	O	A	—	L	H	Alpha 2 ON/OFF H: OFF, L: ON.
36	P24	AGCNTL	O	A	—	H	L	Auto gain control, H: auto adjustment.
37	P23	OPEN	O	A	—	L	H	Loader open signal.
38	P22	CLOSE	O	A	—	L	H	Loader close signal.
39	P21	MD2	O	A	—	H	H	Digital out ON/OFF signal, H: ON.
40	P20	CD/AUX	O	A	—	—	L	DA input source selection output H: AUX, L: CD.
41	P17	G2	O	C	PD	H	L	Grid terminal (display indication).
42	P16	G3	O	C	PD	H	L	Grid terminal (display indication).
43	P15	G4	O	C	PD	H	L	Grid terminal (display indication).
44	P14	G5	O	C	PD	H	L	Grid terminal (display indication).
45	P13	G6	O	C	PD	H	L	Grid terminal (display indication).
46	P12	G7	O	C	PD	H	L	Grid terminal (display indication).
47	P11	G8	O	C	PD	H	L	Grid terminal (display indication).
48	P10	G9	O	C	PD	H	L	Grid terminal (display indication).
49	P07	G1	O	C	PD	H	L	Grid terminal (display indication).
50	P06	G10	O	C	PD	H	L	Grid terminal (display indication).
51	P05	FOCUS	O	C	PD	L	H	Focus error offset L: Focus search.
52	P04	l	O	C	PD	H	L	Segment terminal (display indication).
53	P03	k	O	C	PD	H	L	Segment terminal (display indication).
54	P02	j	O	C	PD	H	L	Segment terminal (display indication).
55	P01	i	O	C	PD	H	L	Segment terminal (display indication).
56	P00	a	O	C	PD	H	L	Segment terminal (display indication).
57	P37	b	O	C	PD	H	L	Segment terminal (display indication).
58	P36	f	O	C	PD	H	L	Segment terminal (display indication).
59	P35	g	O	C	PD	H	L	Segment terminal (display indication).
60	P34	e	O	C	PD	H	L	Segment terminal (display indication).
61	P33	d	O	C	PD	H	L	Segment terminal (display indication).
62	P32	h	O	C	PD	H	L	Segment terminal (display indication).
63	P31	c	O	C	PD	H	L	Segment terminal (display indication).
64	P30	OPTICAL	O	C	—	—	L	Optical output H: OPT L: COAX.
65	P87	SER2	I	C	—	—	—	Digital input for fs detection input 2.
66	P86	SER1	I	C	—	—	—	Digital input for fs detection input 1.
67	P85	ERR	I	C	—	—	—	Digital input for error input.
68	P84	DEP	I	C	—	—	—	Digital input for emphasis ON/OFF input.
69	P83	K4	I	C	—	H	(H)	Key input 4
70	P82	K3	I	C	—	H	(H)	Key input 3
71	P81	K2	I	C	—	H	(H)	Key input 2
72	P80	K1	I	C	—	H	(H)	Key input 1
73	VCC	+5V	I	—	—	—	—	+5V
74	VEE	-30V	I	—	—	—	—	Power supply for FIP drive
75	AVSS	GND	I	—	—	—	—	GND
76	VREF	+5V	I	—	—	—	—	+5V
77	P77	OPT LED	O	A	—	H	L	Optical LED drive output.
78	P76	COAX LED	O	A	—	H	L	COAX LED drive output.
79	P75	SWCL	I	A	—	L	(L)	Close detection switch.
80	P74	SWOP	I	A	—	L	(L)	Open detection switch.

SEMICONDUCTORS

● IC's

BA6392FP (IC102)

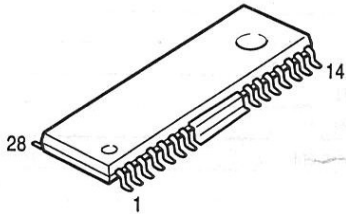

YM3623B (IC104)

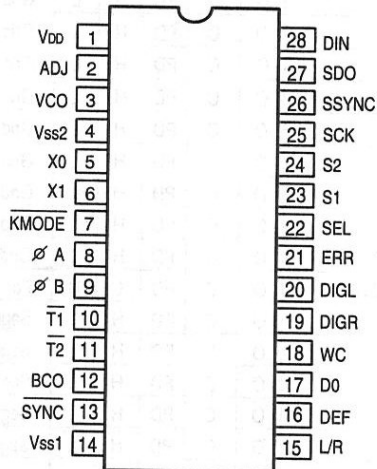
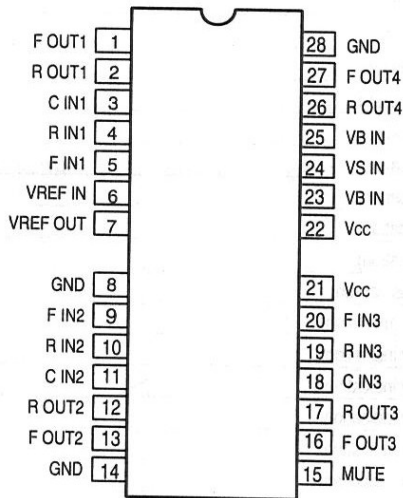
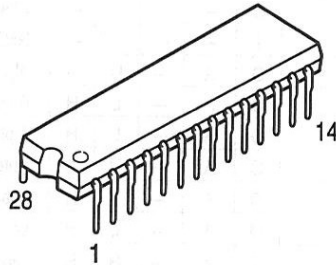

HD74HC157FP (IC110, 111)

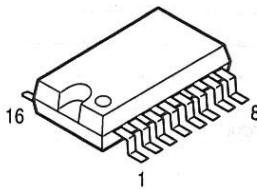

TC74HCU04AP (IC202)

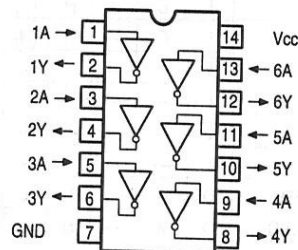
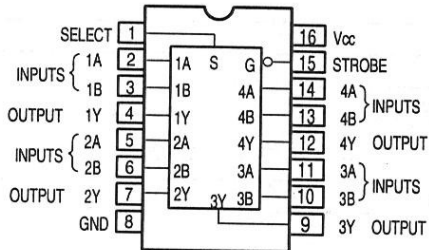
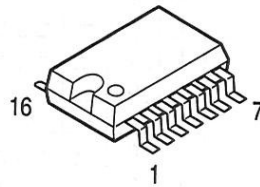

PCM1702P-J (IC301~304)

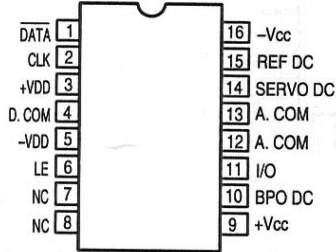
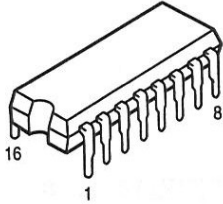

BA15218
(IC103, 105, 309, 310, 901)
OP275GP (IC309, 310)
SSM2139 (IC311, 312)
NE5532 (IC313, 314)

DCD-S10
Asia model only

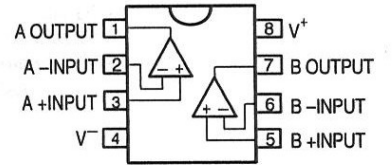
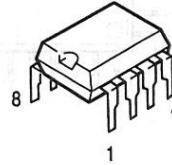

NJM2041DD (IC315~318) DCD-S10 Asia model only
NJM4556AD (IC501)
μPC4570C (IC311~318)

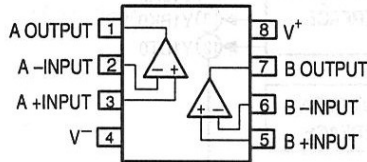
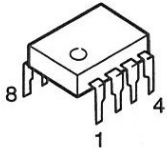

BA15218F (IC350)

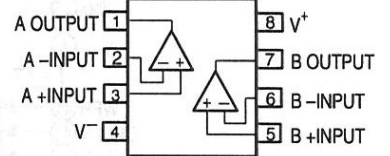
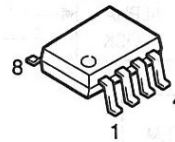

NJM7812FA (IC400)



1: Input
2: GND
3: Output

NJM79M12FA (IC401)



1: GND
2: Output
3: Input

NJM7805FA (S) (IC403)
NJM7806FA (S) (IC402)

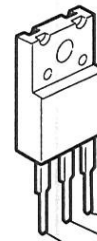

1: Output
2: GND
3: Input

SM5845-AF (IC300)

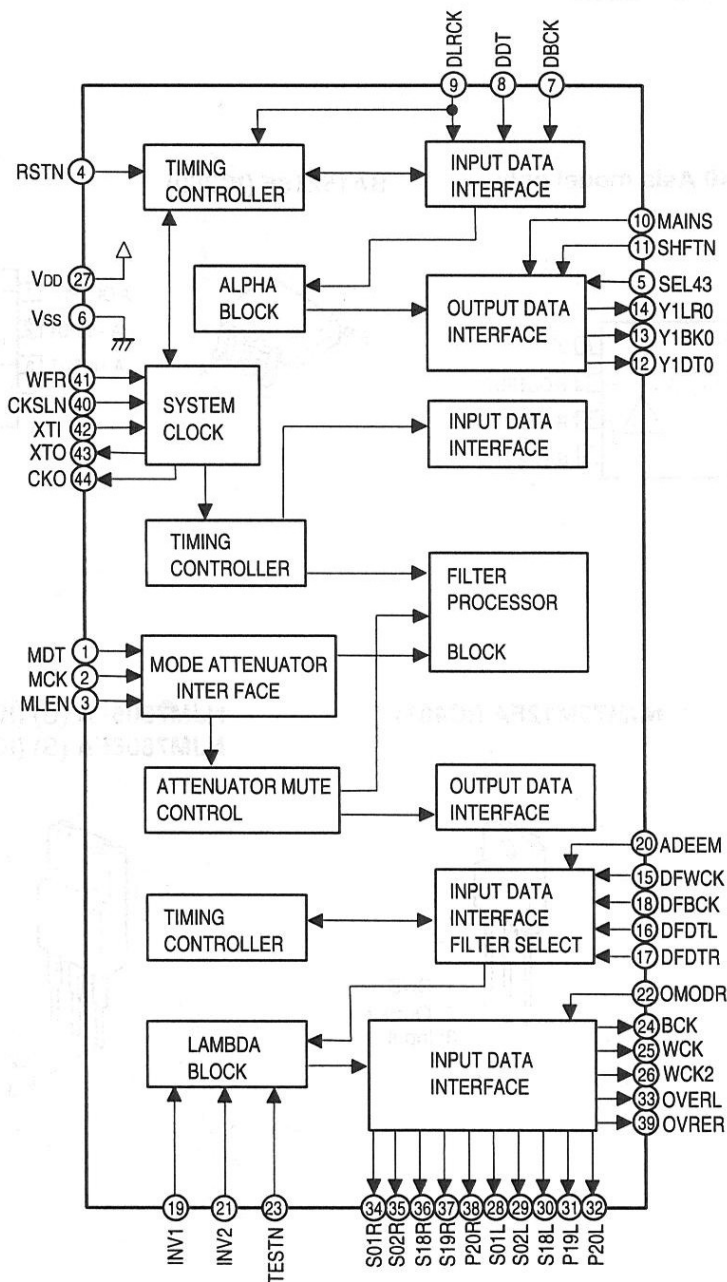
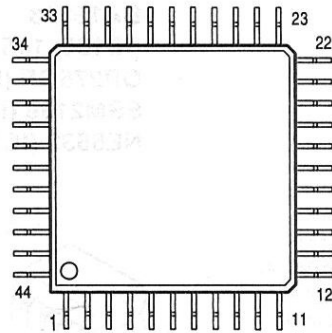

● IC PROTECTOR

NJM78L05A
(IC355, 356)

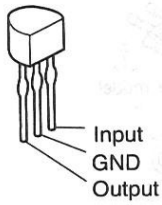

PST529C
(IC409)

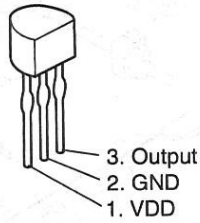

NJM79L05A
(IC357, 358)

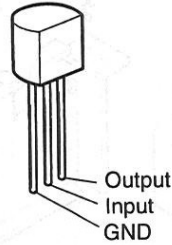

ICP-N20 (IC406, 407)

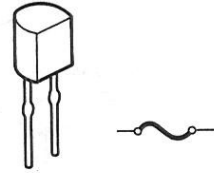

● TRANSISTORS

RN1202 (10K-10K) NPN Type
RN2202 (10K-10K) PNP Type
(BUILT IN RESISTOR)

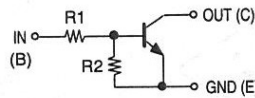
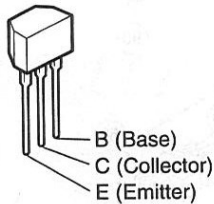

	R1	R2
RN1202	10kohm	10kohm

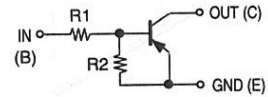

	R1	R2
RN2202	10kohm	10kohm

2SB562 (C)
2SC2878 (A/B)
2SD468 (C)

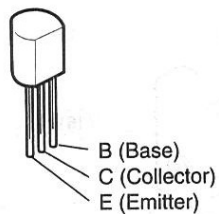

2SC1740S (S)

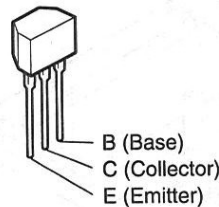

● DIODES

HZS7C-1
HZS33-1

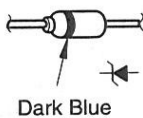

1SS270A



1SR35-200A

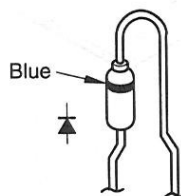

SEL2810R (Red)
SEL2810D (Amber)

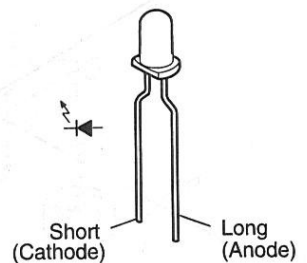

● OTHER

**GP1U571 (Remote Control Receiver)
(IC801)**

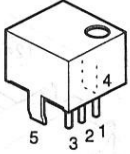

- 1. Vcc
- 2. Output
- 3. GND
- 4. Case Fin
- 5. Case Fin

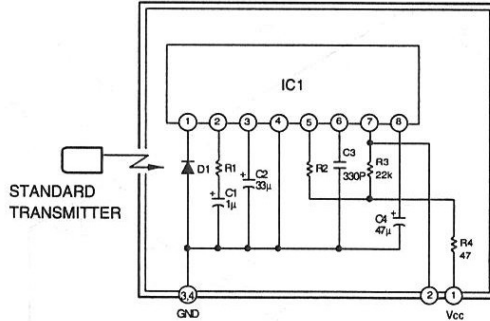

- IC1 : CX20106A Chip
- D1 : PIN Photodiode Chip
- C1,C2,C4 : Aluminum Electrolytic Capacitor
- C3 : SL Characteristic $\pm 5\%$
- R1 : Gain control resistor
- R2 : fo control resistor (Using $\pm 1\%$)
- R (Other than above items) : $\pm 5\%$

EXPLODED VIEW (DCD-S10 Europe, U.S.A. & Canada Models)

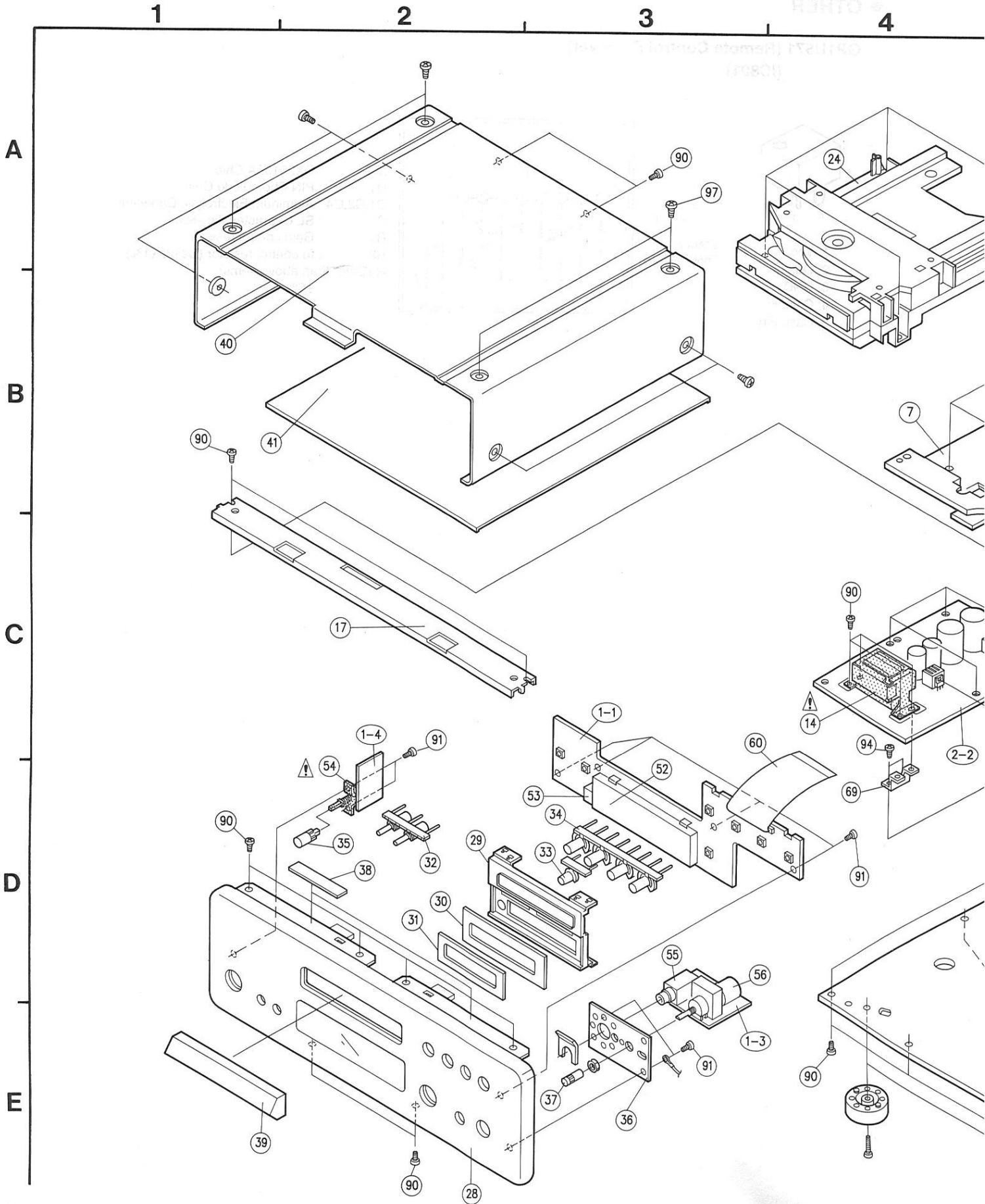

PARTS LIST OF EXPLODED VIEW (DCD-S10 Europe, U.S.A. & Canada Models)

Ref. No.	Part No	Part Name	Remarks	Q'ty	Ref. No.	Part No	Part Name	Remarks	Q'ty
1	1U- 2796 A	Audio P.W.B. Ass'y		1s	54	212 1101 006	Power Switch (TV-5)	SW900	1
1-1	—	Display Unit		(1)	55	204 8322 007	Headphone Jack	PJ301	1
1-2	—	Audio Unit		(1)	56	211 0544 111	Variable Resistor 20kohm	VR300	1
1-3	—	Head Phone Unit		(1)	57	—	—		
1-4	—	Power Switch Unit		(1)	58	269 0098 006	Optical Connector (GP1F32T)	Out U305	1
1-5	—	Balance Out Unit		(1)	59	269 0097 007	Optical connector (GP1F32R)	In U304	1
2	1U- 2798	Digital Servo P.W.B. Ass'y	Europe model	1s	60	009 0090 033	35P FFC Cable	L=145	1
	1U- 2798 D	Digital Servo P.W.B. Ass'y	U.S.A. & Canada models	1s	61	204 8178 028	1P Pin Jack	JK301,302	2
2-1	—	Servo Unit		(1)	62	1U- 2836 A	Servo Amp. P.W.B. Ass'y		1s
2-2	—	Power Supply Unit		(1)	63	214 0127 003	Relay (RY-12W)	RL301	1
3	105 1150 128	Rear Panel		1	64	513 1381 004	Manufac. Date Label	U.S.A. & Canada models only	1
4	105 1152 100	Inside Bottom		1	65	513 0772 009	UL Label	U.S.A. & Canada models only	1
5	105 1151 208	Bottom Cover		1	66	LL- 6442 6	CSA Label	U.S.A. & Canada models only	1
6	104 9044 000	Foot Ass'y		4	67	513 2337 015	Rating Sheet	Europe model	1
7	412 2843 400	Mecha Bracket Ass'y		1		513 2301 038	Rating Sheet	U.S.A. & Canada models only	1
8	—	—			68	513 1220 000	Caution Label		1
9	—	—			69	412 3956 008	Trans Bracket		1
10	—	—			70	122 0196 007	Sheet (Double Circle)		2
11	—	—			71	513 2141 007	Caution Label	U.S.A. & Canada models only	1
12	206 2089 106	AC Cord	Europe model	1	72	513 2065 002	Laser Caution	Europe model only	1
12	206 2110 004	AC Cord	U.S.A. & Canada models	1	73	513 0985 003	Inst. Label	Europe model only	1
13	445 0056 008	Cord Bush		1	74	412 3989 004	SEMKO Bracket	Europe model only	1
14	233 5858 006	Power Trans	U.S.A. & Canada models	1	90	473 7002 021	Screw 3x8 CBTS(S)-B	Black	57
14	233 6151 016	Power Trans	Europe model	1	91	473 7508 017	Screw 3x10 CBTS(P)-B	Black	17
16	411 1317 219	Chassis		1	92	473 7007 013	Screw 4x10 CBTS(S)-B	Black	4
17	411 1318 014	Front Angle		1	93	471 3304 015	Screw 3x8 CBS-Z		4
18	—	—			94	473 7005 073	Screw 3x5 CBTS(S)-Z		4
19	—	—			95	445 0048 016	Cord Holder	L=50	2
20	—	—			96	—	—		
21	205 0428 009	3P Cannon Connector	CN902,903	2	97	471 9043 008	Special Screw		8
22	—	—			PACKING & ACCESSORIES (not included EXPLODED VIEW)				
23	—	—			151	505 0131 076	Cabinet Cover		1
24	337 0041 000	CD Mecha Unit (FG-77)		1	152	504 0092 060	Styrene Paper	For AC Cord	1
25	412 3966 108	Mecha Cover		1	153	503 9275 102	Cushion		2
26	—	—			154	501 1860 027	Carton Case		1
27	461 0889 015	Cushion (T:15)		1	155	515 0690 006	DEL Warranty Home	U.S.A.,Canada only	1
28	144 2428 100	Front Panel Ass'y		1	156	517 0102 040	UPC Label	U.S.A.,Canada only	1
29	146 1542 216	FL Holder		1	157	GEN 3032	Envelope Sub. Ass'y	Europe model	1s
30	143 0919 207	Window		1		GEN 3032 -6	Envelope Sub. Ass'y	U.S.A. & Canada models	1s
31	144 2450 000	Display Frame		1	157-1	505 0038 030	Poly Cover		1
32	113 1708 102	Input Button Ass'y		1	157-2	511 2718 007	Operating Instructions (5)	Europe,U.K. only	1
33	113 1709 004	OP/CL Button Ass'y		1	157-3	511 2721 007	Operating Instructions (3)		1
34	113 1710 006	Function Button Ass'y		1	157-4	204 8121 004	: 2P Pin Cord		1
35	113 9303 101	Power Button Ass'y		1	157-5	399 0263 006	Remote Control Unit	RC-253	1
36	412 3935 003	Headphone Bracket		1	158	513 9111 001	Color Label (Gold)		2
37	113 1713 100	Headphone Button Ass'y		1	159	513 8253 025	Approval Mark	Europe mode only	1
38	129 0140 151	Rubber Sheet	T: 2.0	2					
39	144 2436 150	Loader Panel Ass'y		1					
40	102 9048 000	Top Cover		1					
41	441 1709 006	Top Cover Damper		1					
50	204 8265 009	4P PCA Pin Jack	JK405	1					
51	205 0711 091	15P TBG-S Connector	CB400,401	2					
52	393 4095 007	F.L. Tube FIP10SM6	FL801	1					
53	499 0264 004	Remocon Sensor GP1U571	IC801	1					

NOTE: (Gold) in the Remarks column refers to models with Gold front panels.

(DCD-S10 Asia Model)

Ref. No.	Part No	Part Name	Remarks	Q'ty	Ref. No.	Part No	Part Name	Remarks	Q'ty
1	1U- 2796 M	Audio P.W.B. Ass'y		1s	62	1U- 2836 A	Servo Amp. P.W.B. Ass'y		1s
1-1	—	Display Unit		(1)	63	214 0127 003	Relay (RY-12W)	RL301	1
1-2	—	Audio Unit		(1)	64	513 1606 006	Power Trans Label (A)		1
1-3	—	Head Phone Unit		(1)	65	513 1607 005	Power Trans Label (B)		1
1-4	—	Power Switch Unit		(1)	66	125 0078 001	Squara Washer		2
1-5	—	Balance Out Unit		(1)	67	513 2299 043	Rating Sheet		1
2	1U- 2797 M	Digital Servo P.W.B. Ass'y		1s	68	513 1220 000	Caution Label	Bottom Cover	1
2-1	—	Servo Unit		(1)	69	412 3956 008	Trans Bracket		1
2-2	—	Power Supply Unit		(1)					
3	105 1170 001	Rear Panel		1	90	473 8034 001	Screw 3x8 CBTS(B)-CU		48
4	105 1152 100	Inside Bottom		1	91	473 7518 104	Screw 3x10 CBTS(P)-CU		18
5	105 1151 211	Bottom Cover		1	92	473 7007 026	Screw 4x16 CBTS(S)-B	Black	4
6	104 0267 006	Foot Ass'y		4	93	473 7508 017	Screw 3x10 CBTS(S)-B	Black	6
7	412 2843 400	Mecha Fix Bracket		1	94	473 7002 021	Screw 3x8 CBTS(S)-B	Black	2
8	129 0214 003	Bass Rubber (l)		1	95	445 0048 016	Cord Holder	L=50	2
9	129 0215 002	Bass Rubber (s)		1	96	—	—		
10	412 3992 101	Pin Jack Damper		1	97	471 9043 008	Special Screw		8
11	129 0212 005	Foot Damper		4	98	471 3830 000	Screw 3x6 CBS-CU		4
14	233 6171 009	Power Trans (Audio)		1	PACKING & ACCESSORIES (not included EXPLODED VIEW)				
15	233 6172 008	Power Trans (Digital)		1	151	505 0131 076	Cabinet Cover		1
16	411 1317 219	Chassis		1	152	504 0092 060	Styrene Paper	For AC Cord	1
17	411 1318 014	Front Angle		1	153	503 9275 102	Cushion		2
18	—	—			154	501 1860 056	Carton Case		1
20	203 3962 003	AC Inlet		1	155	GEN 3032 -3	Envelop Sub. Ass'y		1s
21	205 0428 009	3P Cannon Connector	CN902,903	2	155-1	505 0038 030	Poly Cover		(1)
22	129 0213 004	Trans Damper		2	155-2	511 2721 007	Operating Instructions (3)		(1)
23	412 3957 007	Trans Plate		2	155-3	511 2722 006	Operating Instructions		(1)
24	337 0041 000	CD Mecha Unit (FG-77)		1	155-4	204 8121 004	: 2P Pin Cord		(1)
25	412 3966 108	Mecha Cover		1	155-5	399 0263 006	Remote Control Unit	RC-253	(1)
26	441 1708 007	Mecha Cover Damper		2	155-6	202 0044 002	AC Plug Adaptor		(1)
27	461 0889 015	Cushion (T:15)		1	155-7	206 2130 000	AC Cord W/Con & Plug		(1)
28	144 2428 100	Front Panel Ass'y		1	155-8	511 2773 000	Notice Sheet		(1)
29	146 1542 216	FL Holder		1	156	513 9111 001	Color Label (Gold)		2
30	143 0919 207	Window		1					
31	144 2450 000	Display Frame		1					
32	113 1708 102	Input Button Ass'y		1					
33	113 1709 004	OP/CL Button Ass'y		1					
34	113 1710 006	Function Button Ass'y		1					
35	113 9303 101	Power Button Ass'y		1					
36	412 3935 003	Headphone Bracket		1					
37	113 1713 100	Headphone Button Ass'y		1					
38	129 0140 151	Rubber Sheet	T: 2.0	2					
39	144 2436 150	Loader Panel Ass'y		1					
40	102 9048 000	Top Cover		1					
41	441 1709 006	Top Cover Damper		1					
50	204 9801 006	1p Pin Jack		2					
51	205 0711 091	15P TBG-S Connector	CB400, 401	2					
52	393 4095 007	E.L. Tube FIP10SM6	FL801	1					
53	499 0264 004	Remocon Sensor GP1U571	IC801	1					
54	212 1101 006	Power Switch	SW900	1					
55	204 8322 007	Headphone Jack	PJ301	1					
56	211 0544 111	Variable Resistor 20kohm	VR300	1					
57	204 8406 017	1P Pin Jack	JK403,404	2					
58	269 0098 006	Optical Connector (GP1F32T)	Out U305	1					
59	269 0097 007	Optical connector (GP1F32R)	In U304	1					
60	009 0090 033	35P FFC Cable	L=145	1					
61	204 8178 028	1P Pin Jack	JK301,302	2					

EXPLODED VIEW (DCD-S10 Asia Model)

1

2

3

4

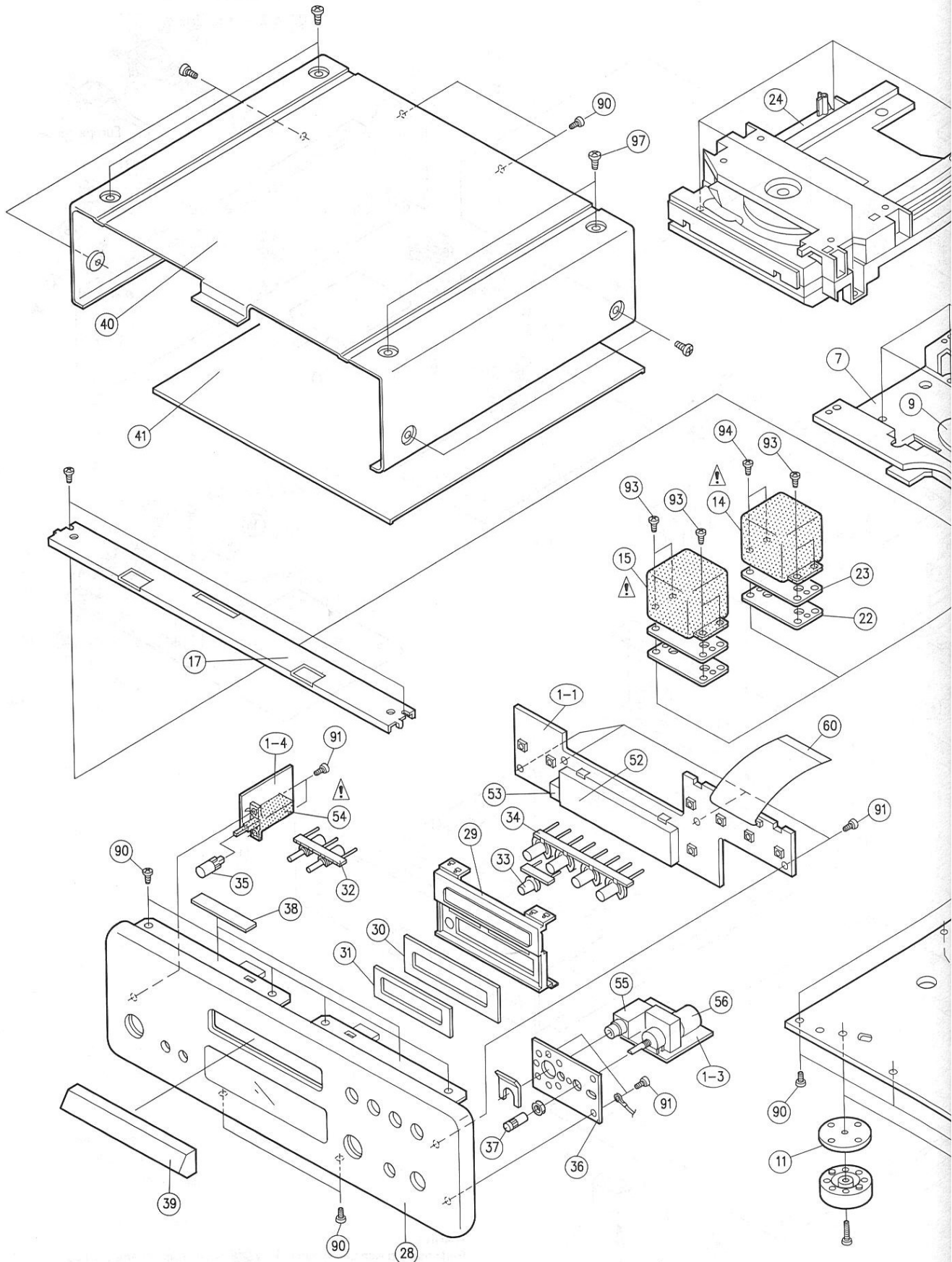

5

6

7

8

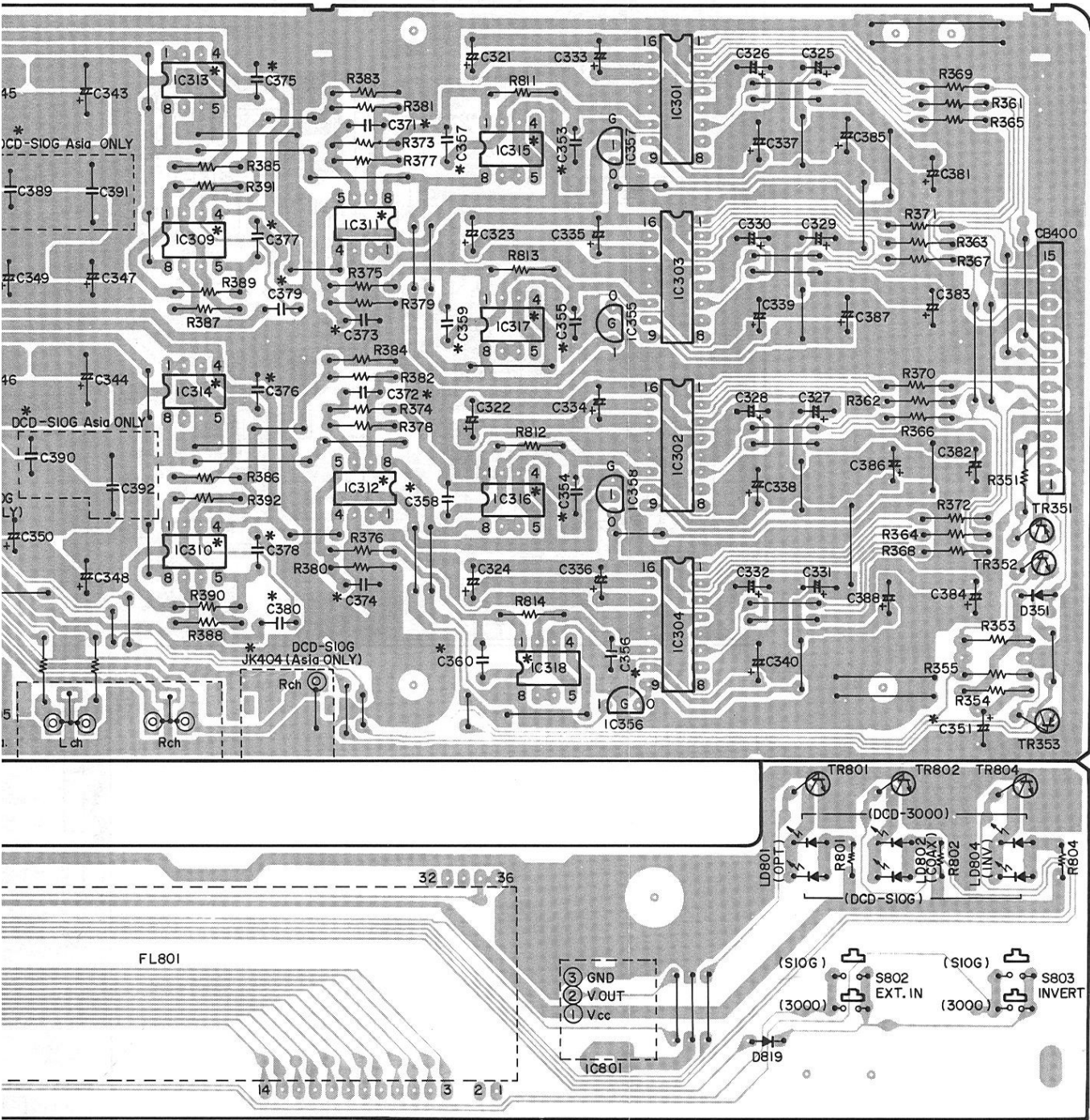

A

B

C

D

E

	IC315-318	C351	C353-356	C357-360	C371,372	C373,374	C375-380	C389,390	C391,392	C503	C504	JK403,404	JK405	CB401,402	R335-999
μPC4570C	220μF/25V (SME)	270pF/100V Film	100pF/100V Film	180pF/100V Film	820pF/100V Film	0.0027μF/100V Film	—	—	—	47μF/16V (SME)	2200μF/16V (SME)	—	4 Pin Jack	—	Carbon Film
μPC4570C	220μF/25V (SME)	270pF/100V Film	100pF/100V Film	180pF/100V Film	820pF/100V Film	0.0027μF/100V Film	—	—	—	47μF/16V (SME)	2200μF/16V (SME)	—	4 Pin Jack	—	Carbon Film
μPC4570C	220μF/25V (SME)	270pF/100V Film	100pF/100V Film	180pF/100V Film	820pF/100V Film	0.0027μF/100V Film	—	—	—	47μF/16V (SME)	2200μF/16V (SME)	—	4 Pin Jack	—	Carbon Film
μPC4570C	220μF/25V (SME)	270pF/100V Film	100pF/100V Film	180pF/100V Film	820pF/100V Film	0.0027μF/100V Film	—	—	1μF/63V	47μF/16V (SME)	2200μF/16V (SME)	—	4 Pin Jack	—	Carbon Film
μPC4570C	220μF/25V (SME)	270pF/100V Film	100pF/100V Film	180pF/100V Film	820pF/100V Film	0.0027μF/100V Film	—	—	1μF/63V	47μF/16V (SME)	2200μF/16V (SME)	—	4 Pin Jack	—	Carbon Film
NJM2041DD	220μF/25V (ARD)	270pF/125V Polystyrol	100pF/125V Polystyrol	180pF/125V Polystyrol	820pF/125V Polystyrol	0.0027μF/125V Polystyrol	0.01μF/125V Polystyrol	—	—	47μF/16V (ARD)	2200μF/16V (ASF)	1 Pin Jack	—	2PVH Con. Base	Carbon Film (PSNB)

P.W. BOARD UNIT ASS'Y

1

2

3

4

1U-2796 AUDIO UNIT

1U-2796 DCD-3000 Europe, U.S.A. & Canada and Multi-Voltage Models

1U-2796A DCD-S10 Europe, U.S.A. & Canada Models

1U-2796M DCD-S10 Asia Model

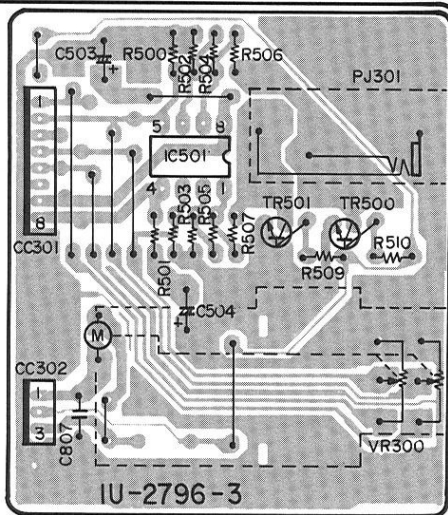
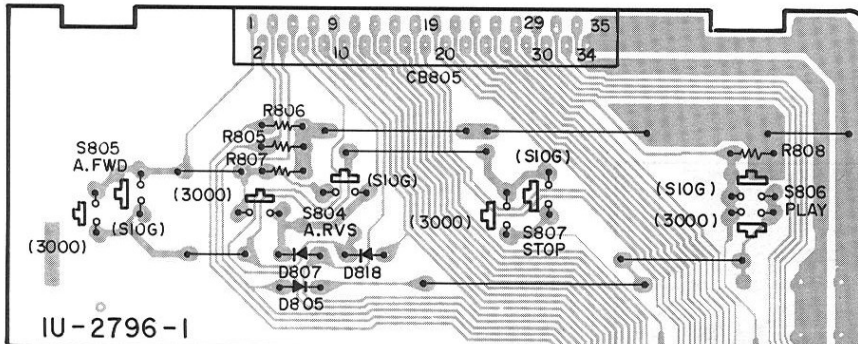
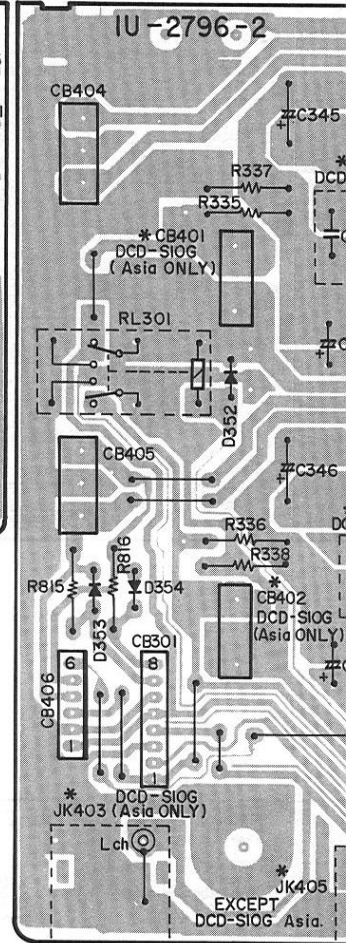
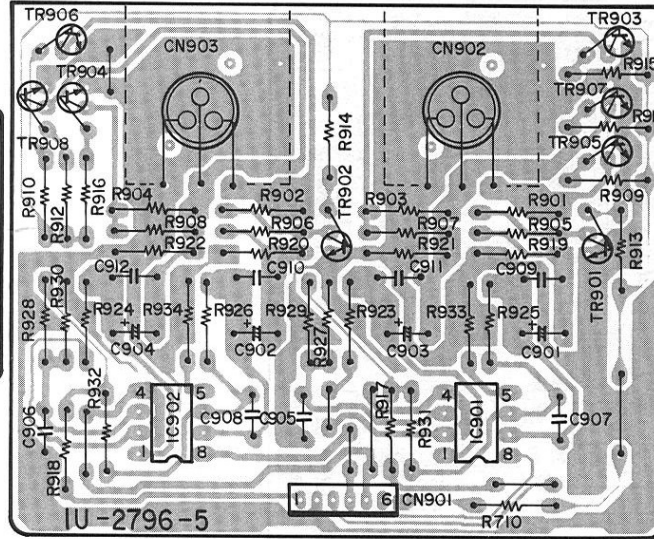
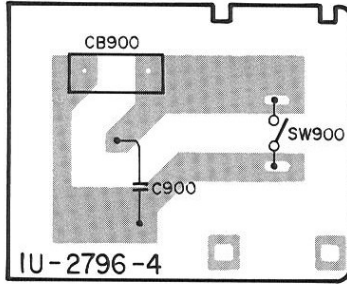

		Unit No.	IC309,310	IC311,312	IC313,314	IC315,316
DCD-3000	Europe	1U-2796	μPC4570C	μPC4570C	μPC4570C	μPC4570C
	U.S.A. & Canada	1U-2796	μPC4570C	μPC4570C	μPC4570C	μPC4570C
	Multi-voltage	1U-2796	μPC4570C	μPC4570C	μPC4570C	μPC4570C
DCD-S10	Europe	1U-2796A	μPC4570C	μPC4570C	μPC4570C	μPC4570C
	U.S.A. & Canada	1U-2796A	μPC4570C	μPC4570C	μPC4570C	μPC4570C
	Asia model	1U-2796M	OP275GP	SSM2139	NE5532	NJ4558

5

6

7

8

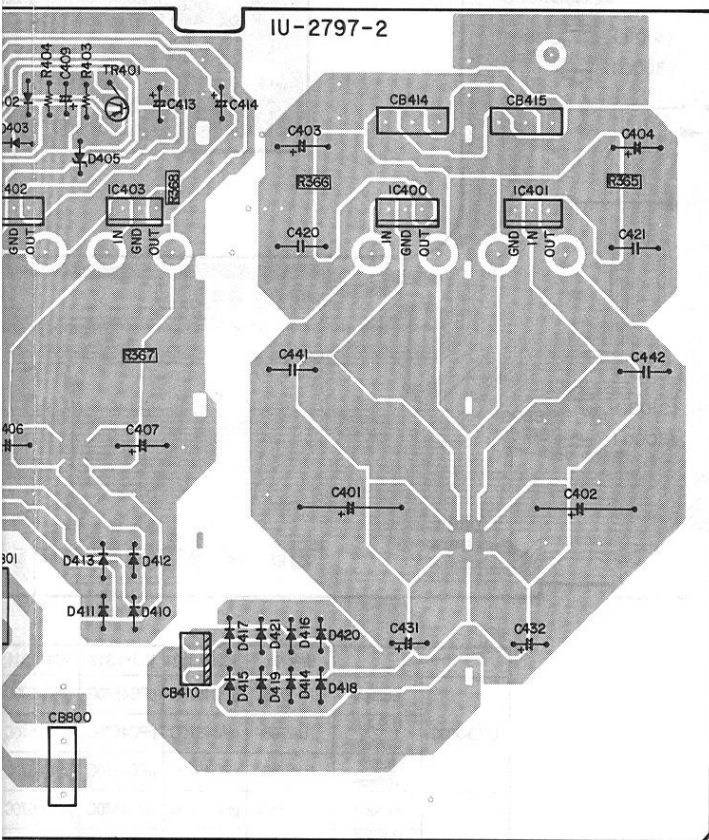
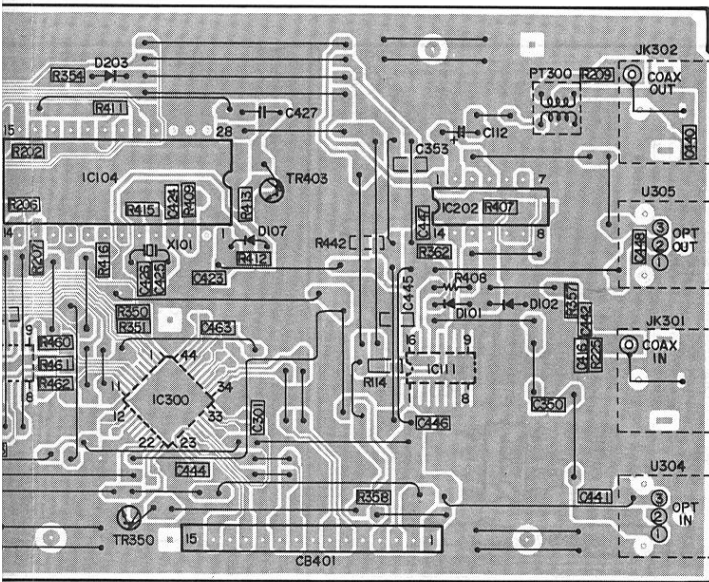

1U-2798 DIGITAL SERVO UNIT

- 1U-2798 DCD-3000, DCD-S10 Europe Models
- 1U-2798D DCD-3000, DCD-S10 U.S.A. & Canada Models
- 1U-2798B DCD-3000 Multi-Voltage Model

		Unit No.	SW802
DCD-S10	Europe	1U-2798	—
	U.S.A. & Canada	1U-2798D	—
DCD-3000	Europe	1U-2798	—
	U.S.A. & Canada	1U-2798D	—
	Multi-Voltage	1U-2798B	Vol. Sel. SW

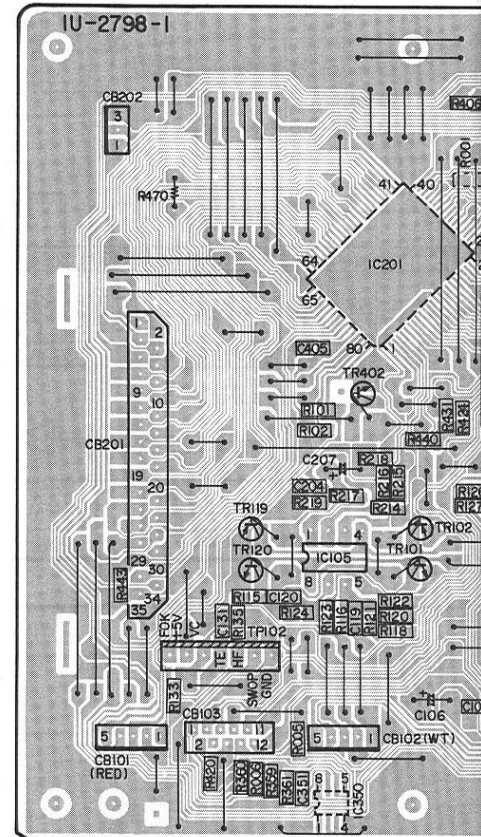

1U-2836A SERVO AMP UNIT

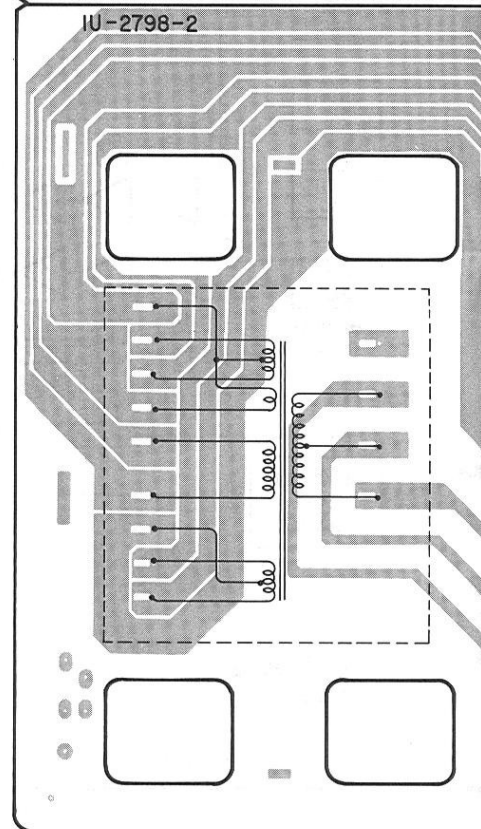
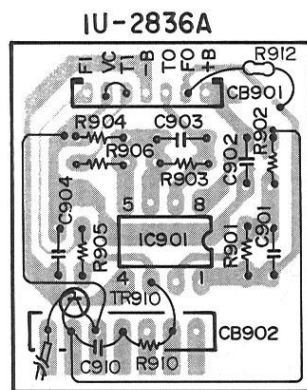

5

6

7

8

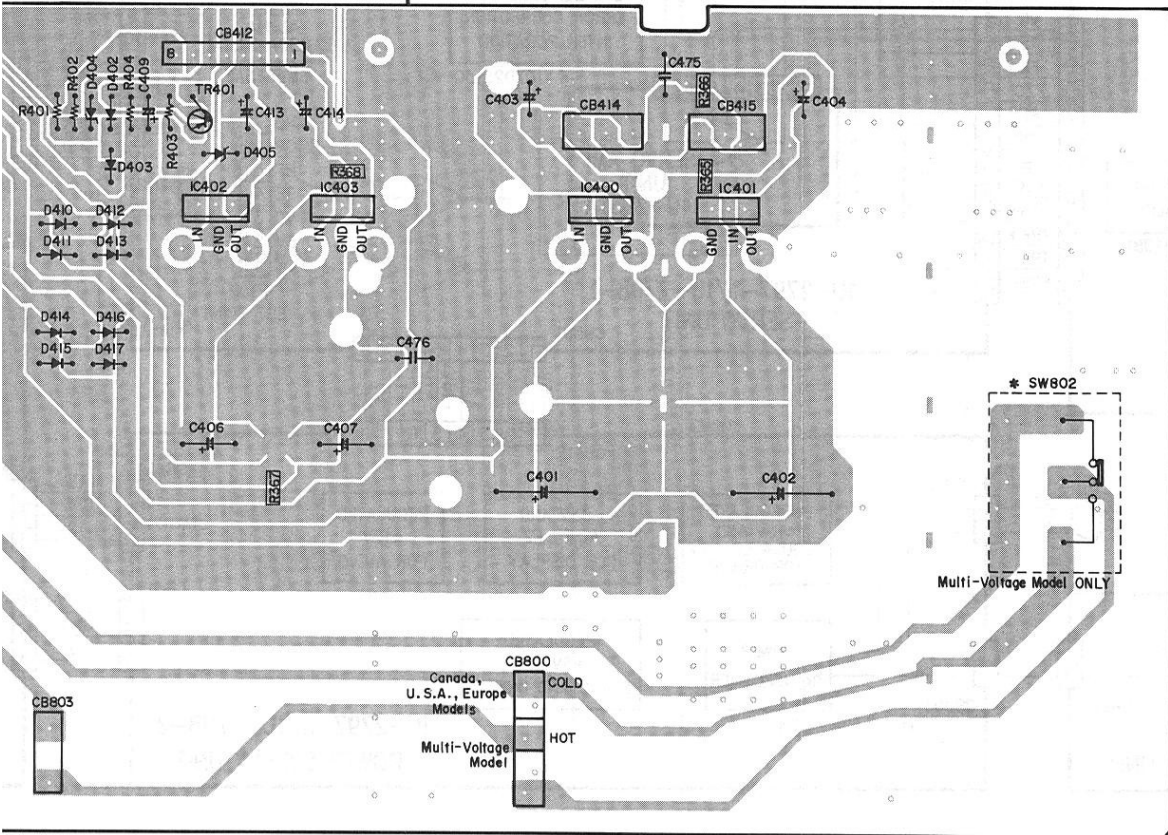
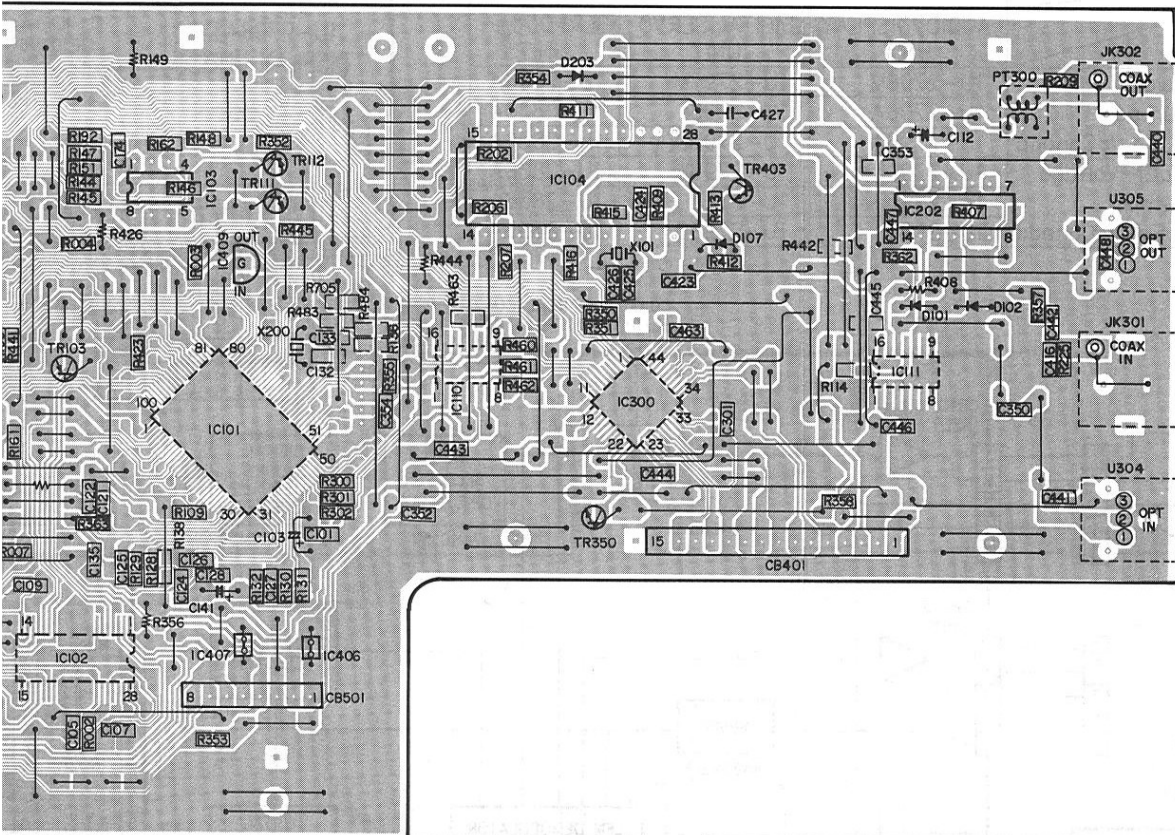

A

B

C

D

E

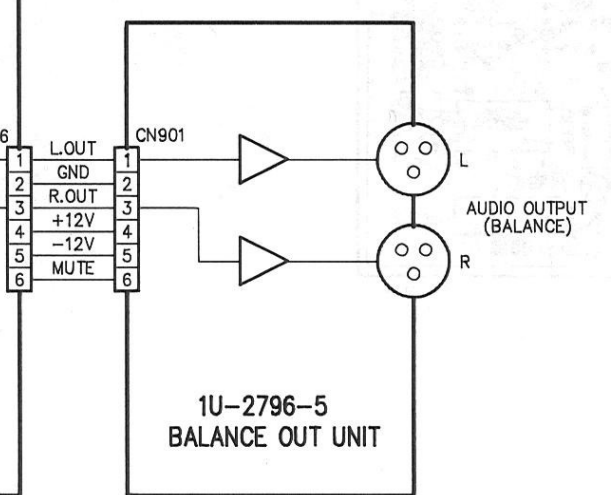
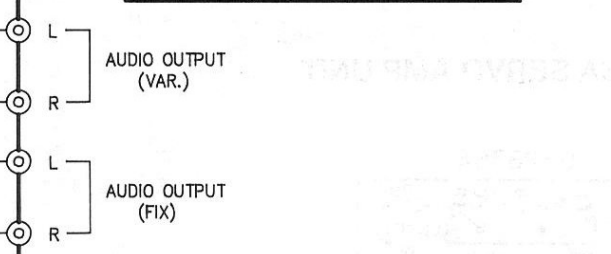
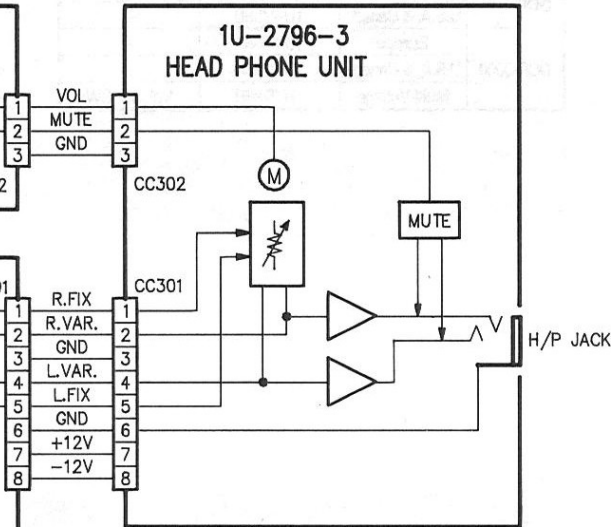
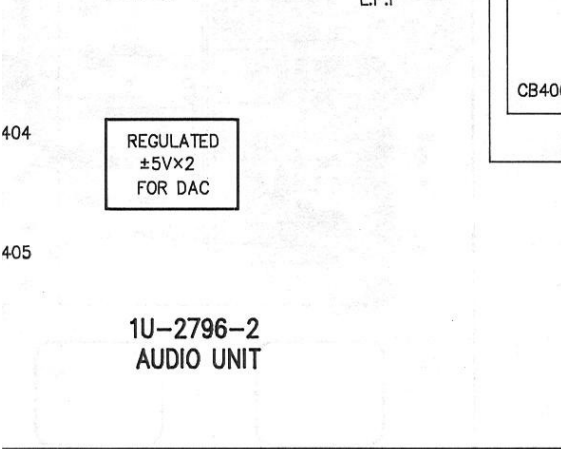
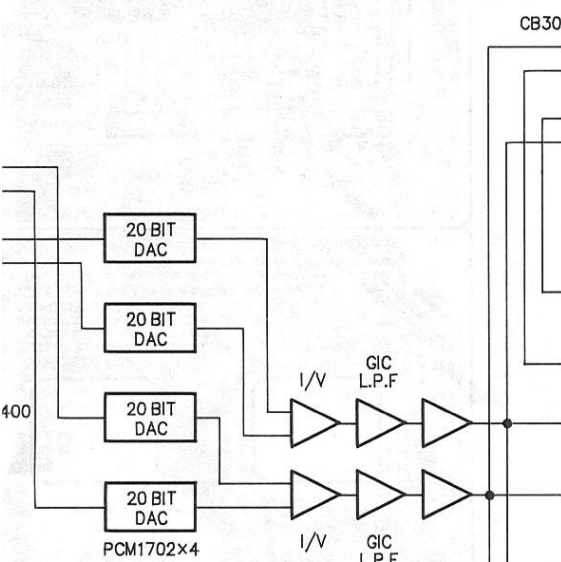
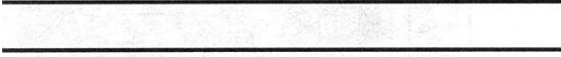
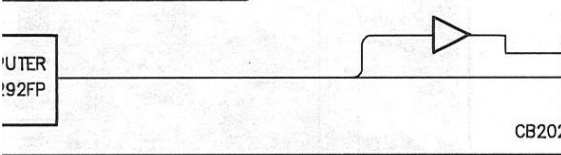
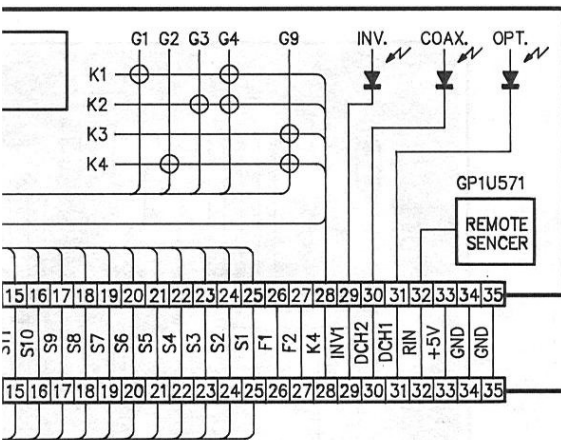

SCHEMATIC DIAGRAM-1/3

1

2

3

4

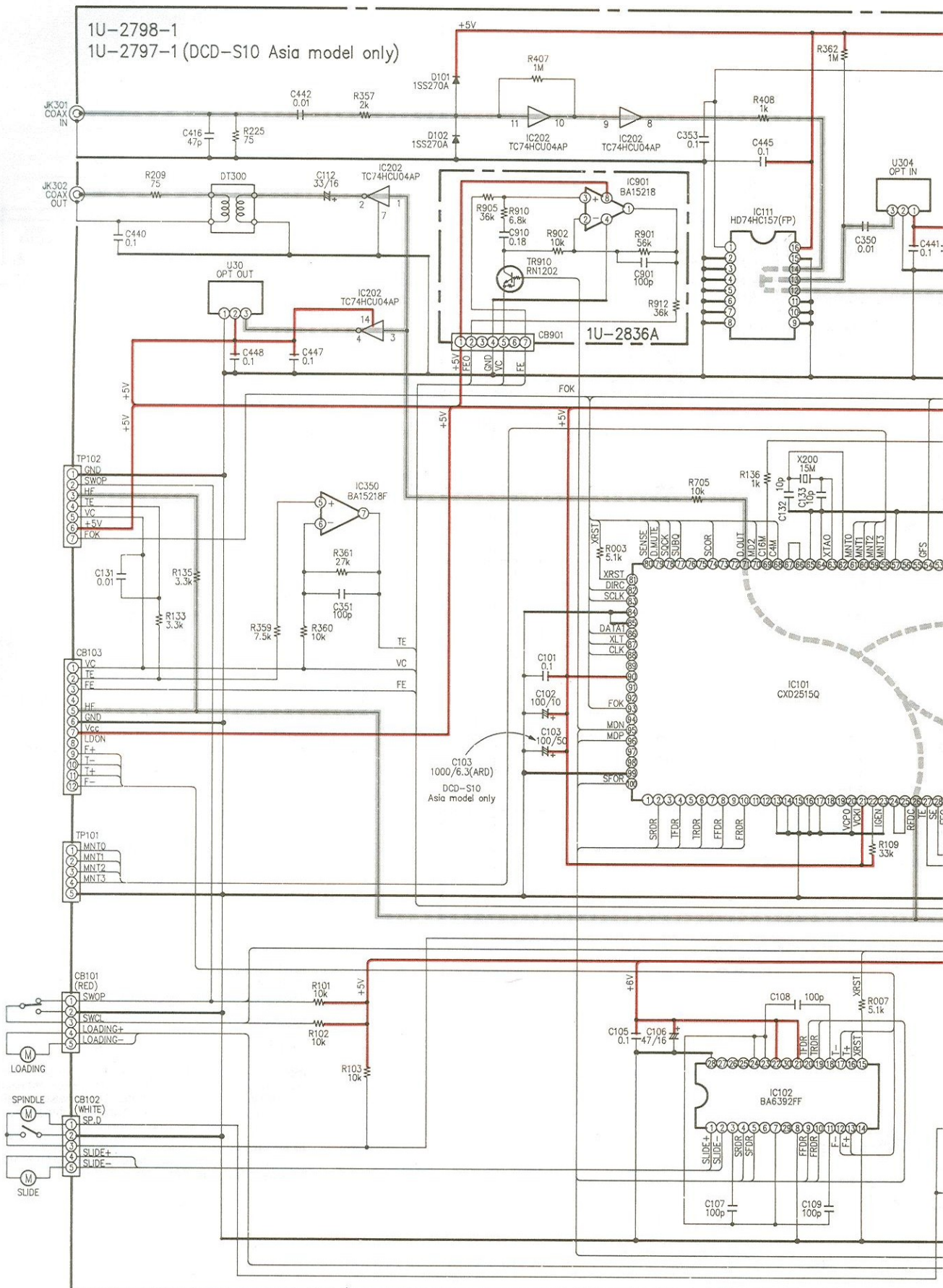

SCHEMATIC DIAGRAM-2/3

1

2

3

4

A

B

C

D

E

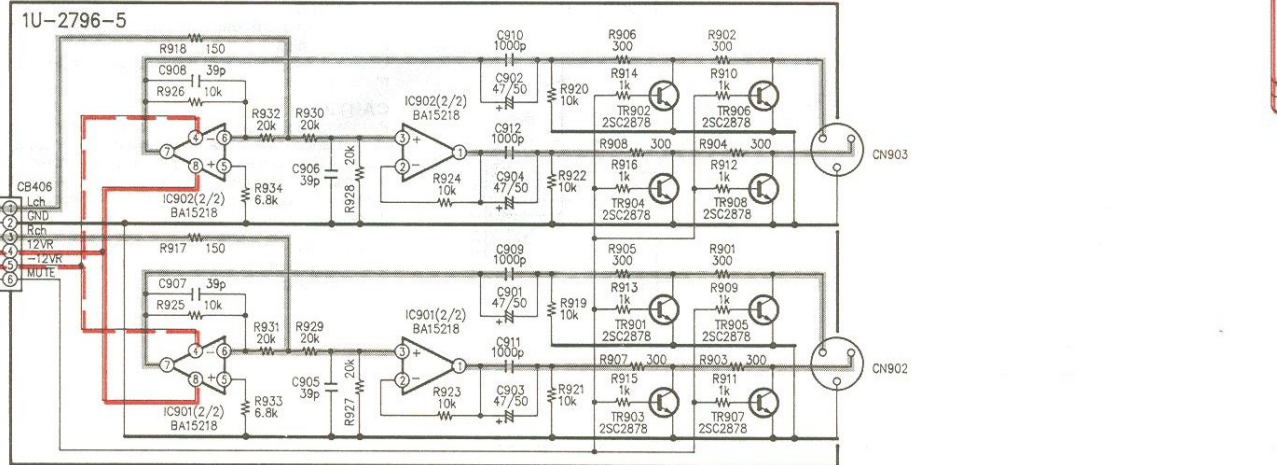
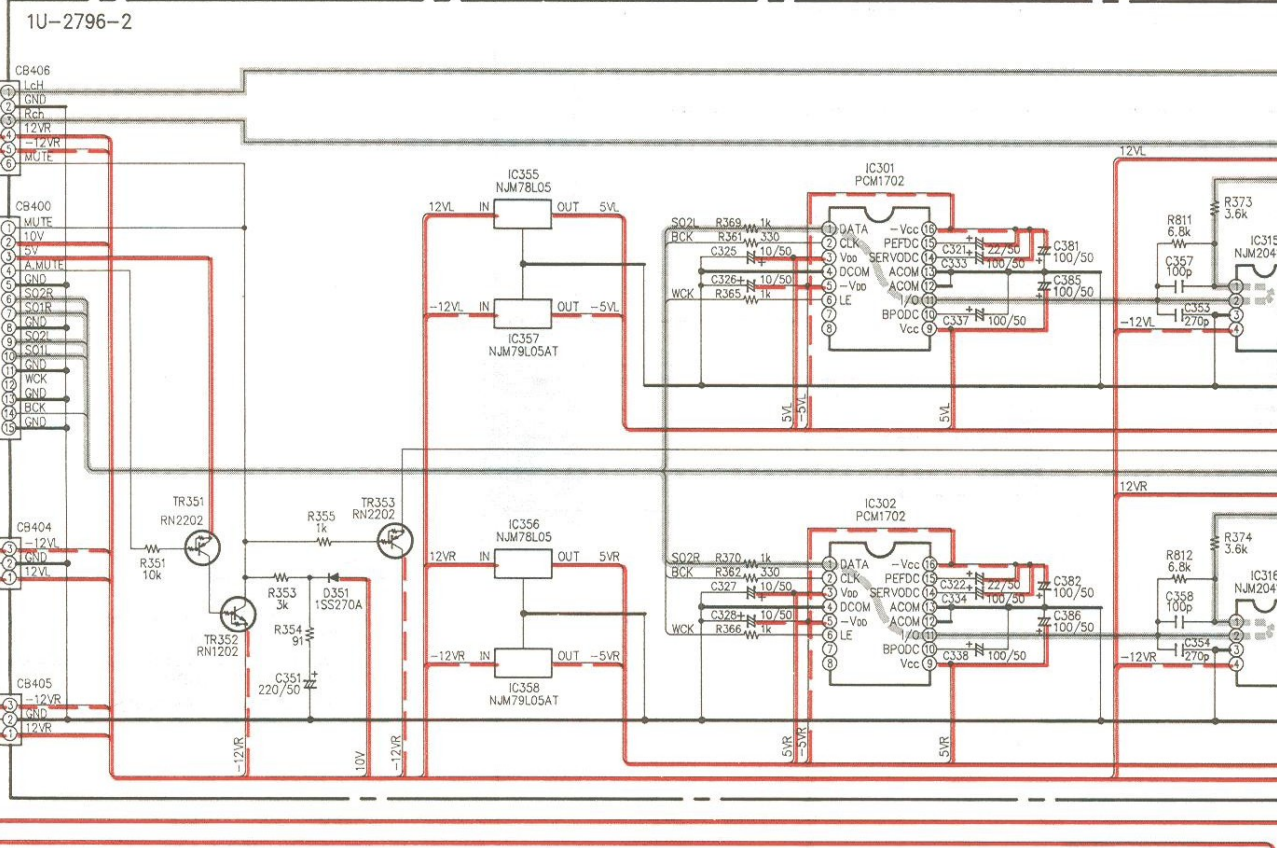
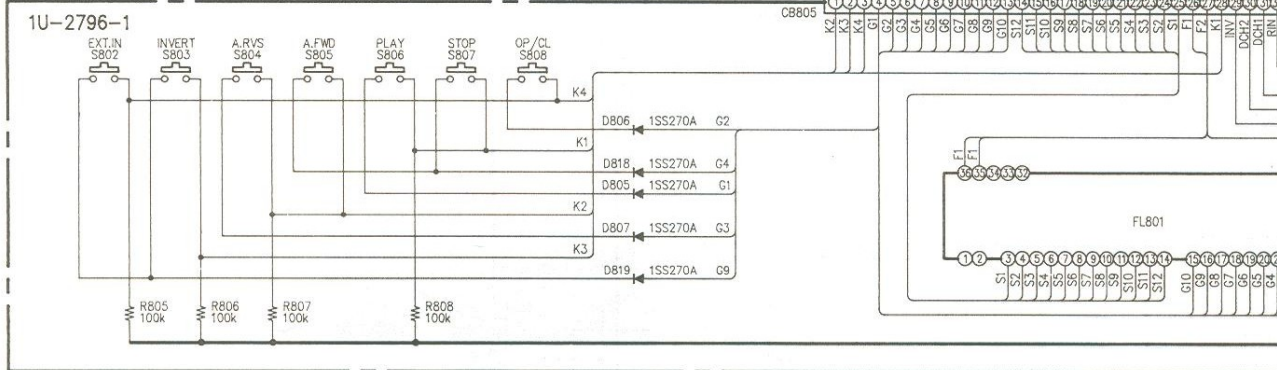

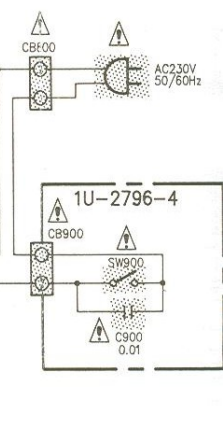
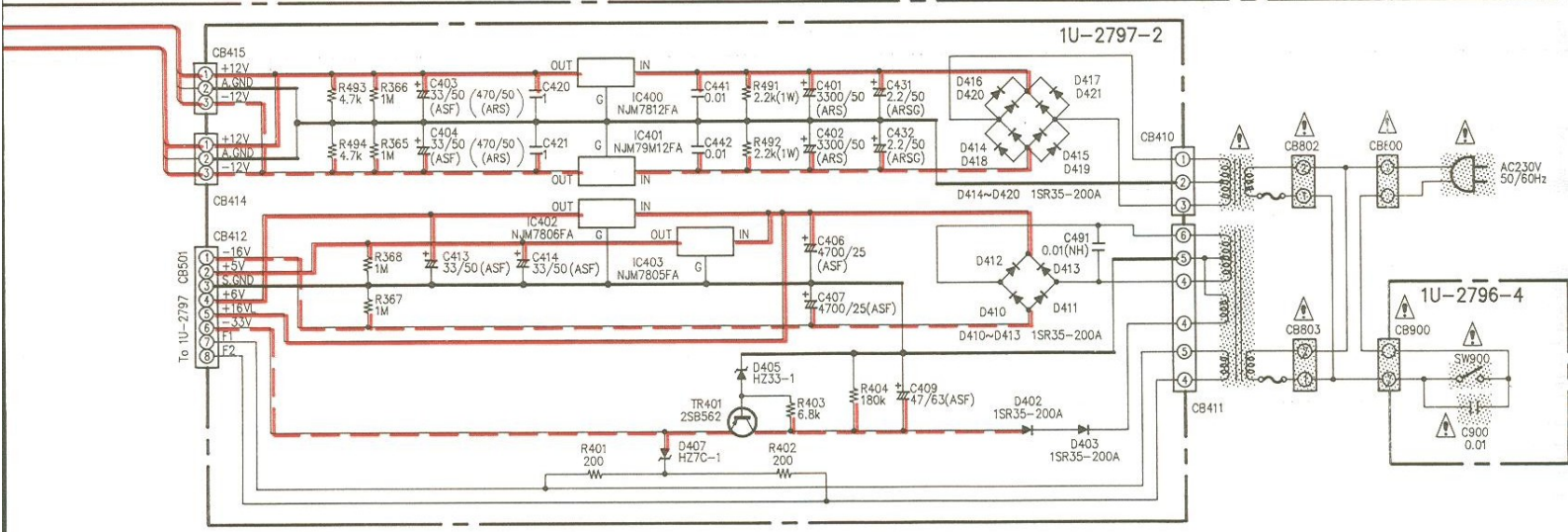
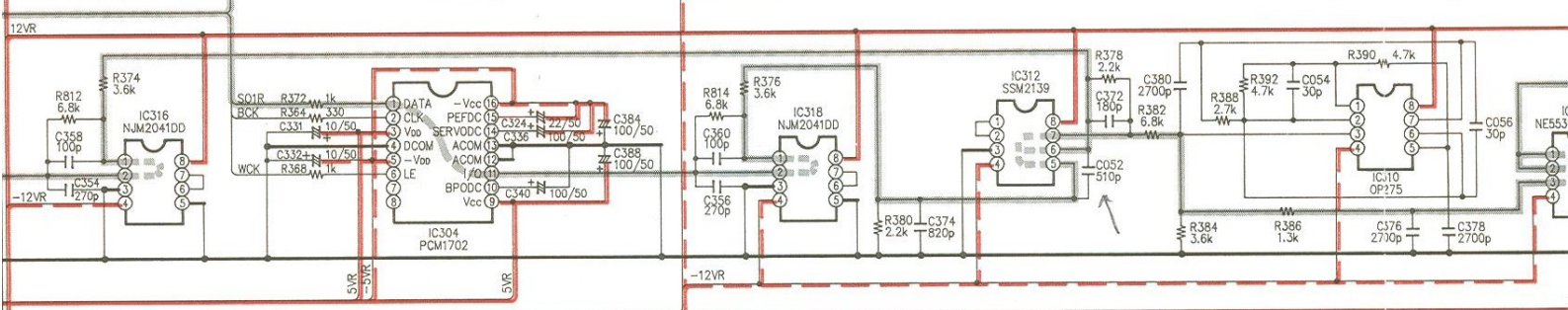
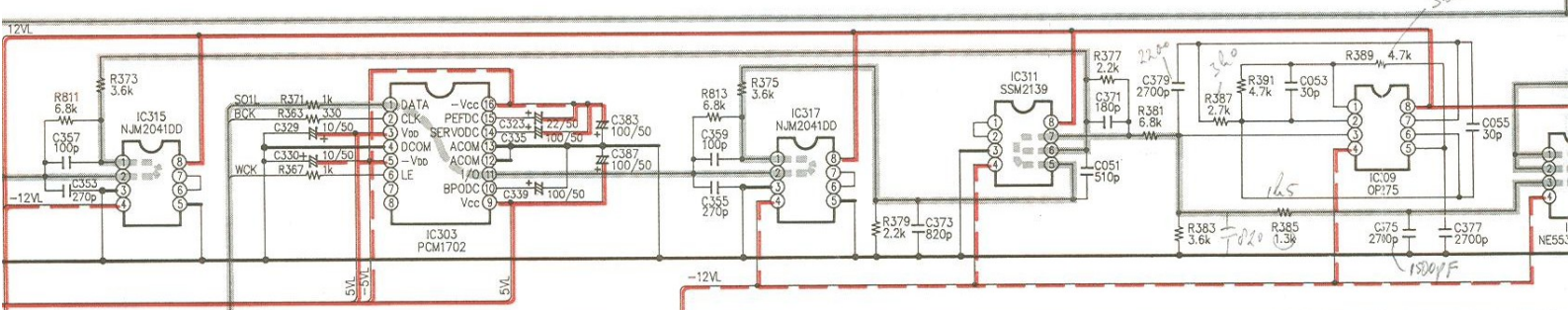
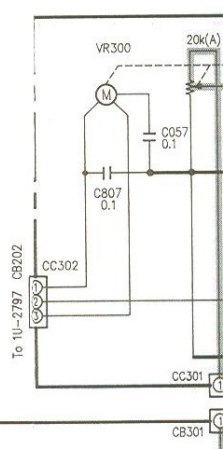
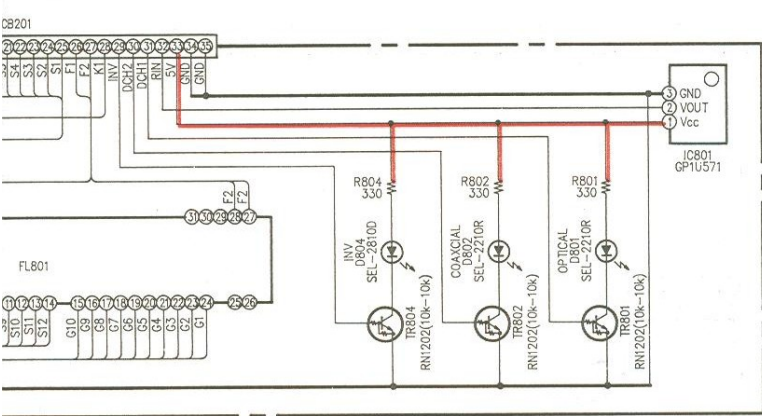

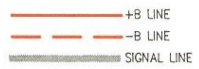
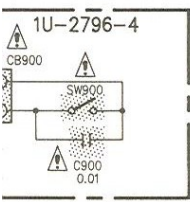
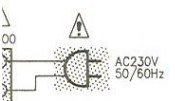
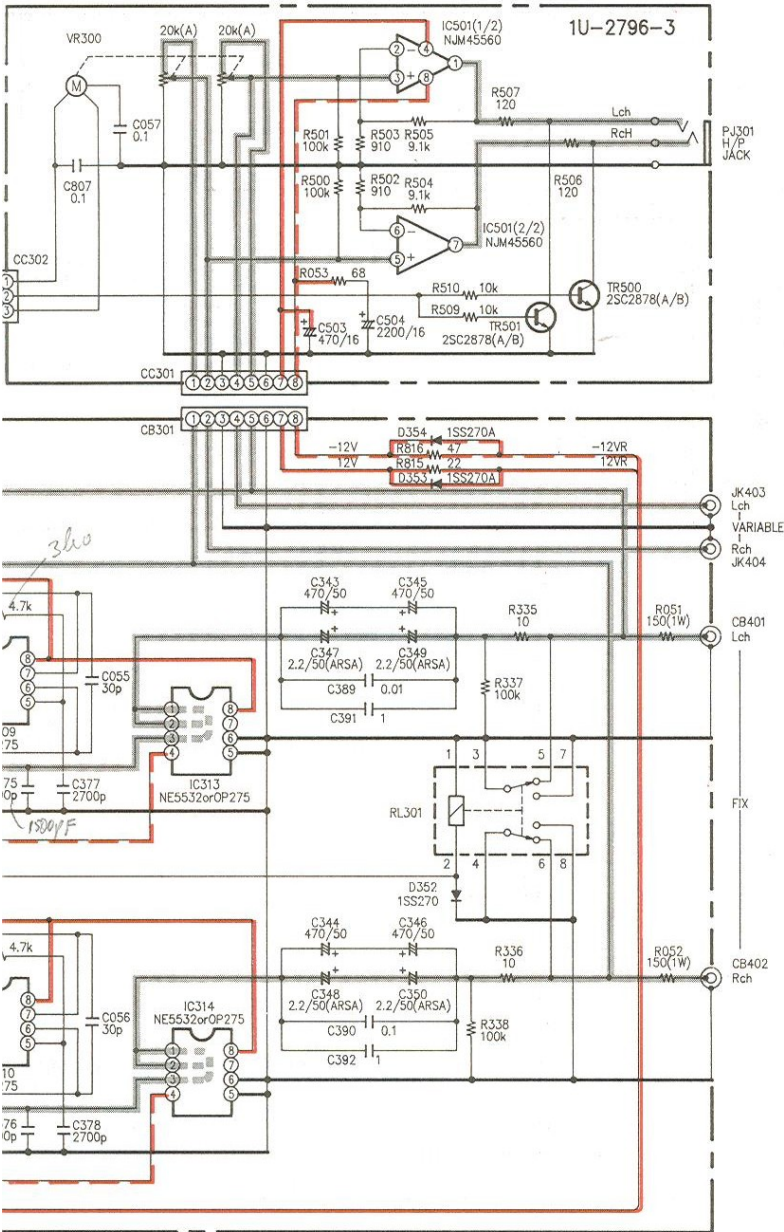

NOTES
 ALL RESISTANCE VALUES IN OHM. k=1,000 OHM, M=1,000,000 OHM
 ALL CAPACITANCE VALUES IN MICRO FARAD. P=MICRO-MICRO FARAD
 EACH VOLTAGE AND CURRENT ARE MEASURED AT NO SIGNAL INPUT CONDITION.
 CIRCUIT AND PARTS ARE SUBJECT TO CHANGE WITHOUT PRIOR NOTICE.

WARNING:
 Parts marked with this symbol  have critical characteristics. Use ONLY replacement parts recommended by the manufacturer.

CAUTION:
 Before returning the unit to the customer, make sure you make either (1) a leakage current check or (2) a line to chassis resistance check. If the leakage current exceeds 0.5 milliamps, or if the resistance from chassis to either side of the power cord is less than 240 kohms, the unit is defective.

WARNING:
 DO NOT return the unit to the customer until the problem is located and corrected.

8

9

10

11

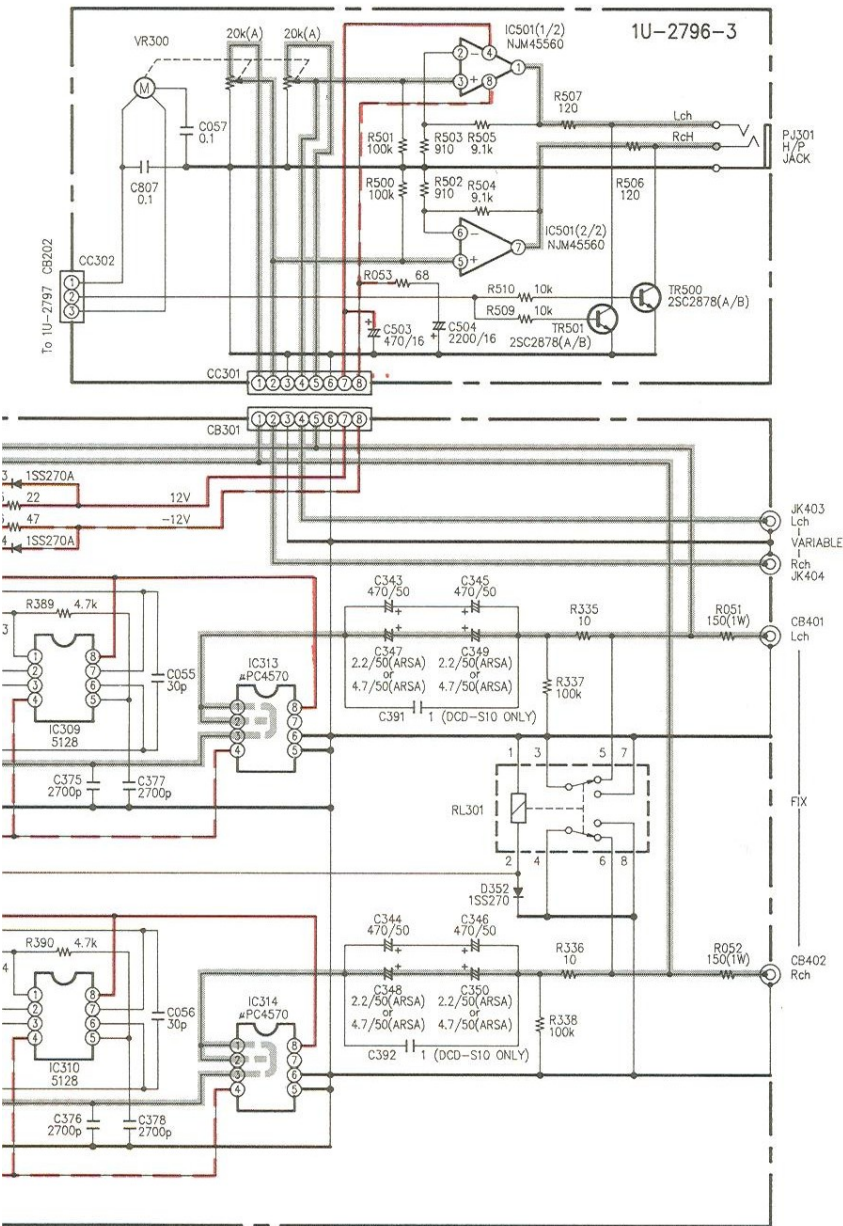

NOTES

ALL RESISTANCE VALUES IN OHM. k=1,000 OHM, M=1,000,000 OHM
 ALL CAPACITANCE VALUES IN MICRO FARAD.
 P=MICRO-MICRO FARAD
 EACH VOLTAGE AND CURRENT ARE MEASURED AT NO SIGNAL INPUT CONDITION.
 CIRCUIT AND PARTS ARE SUBJECT TO CHANGE WITHOUT PRIOR NOTICE.

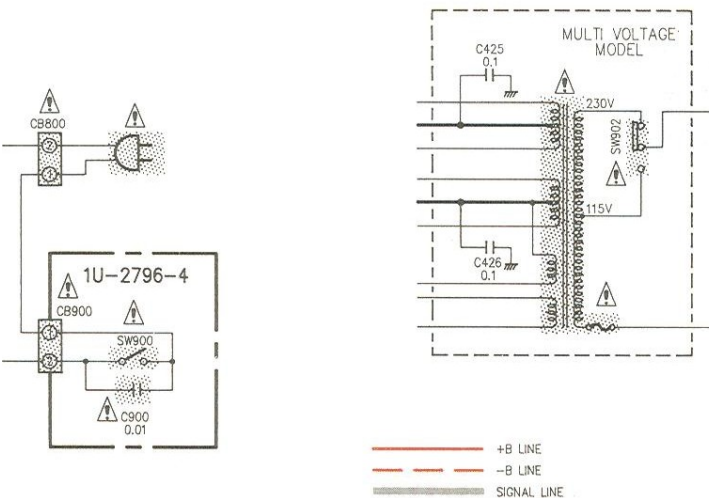

WARNING:

Parts marked with this symbol have critical characteristics. Use ONLY replacement parts recommended by the manufacturer.

CAUTION:

Before returning the unit to the customer, make sure you make either (1) a leakage current check or (2) a line to chassis resistance check. If the leakage current exceeds 0.5 milliamps, or if the resistance from chassis to either side of the power cord is less than 240 kohms, the unit is defective.

WARNING:

DO NOT return the unit to the customer until the problem is located and corrected.

A

B

C

D

E

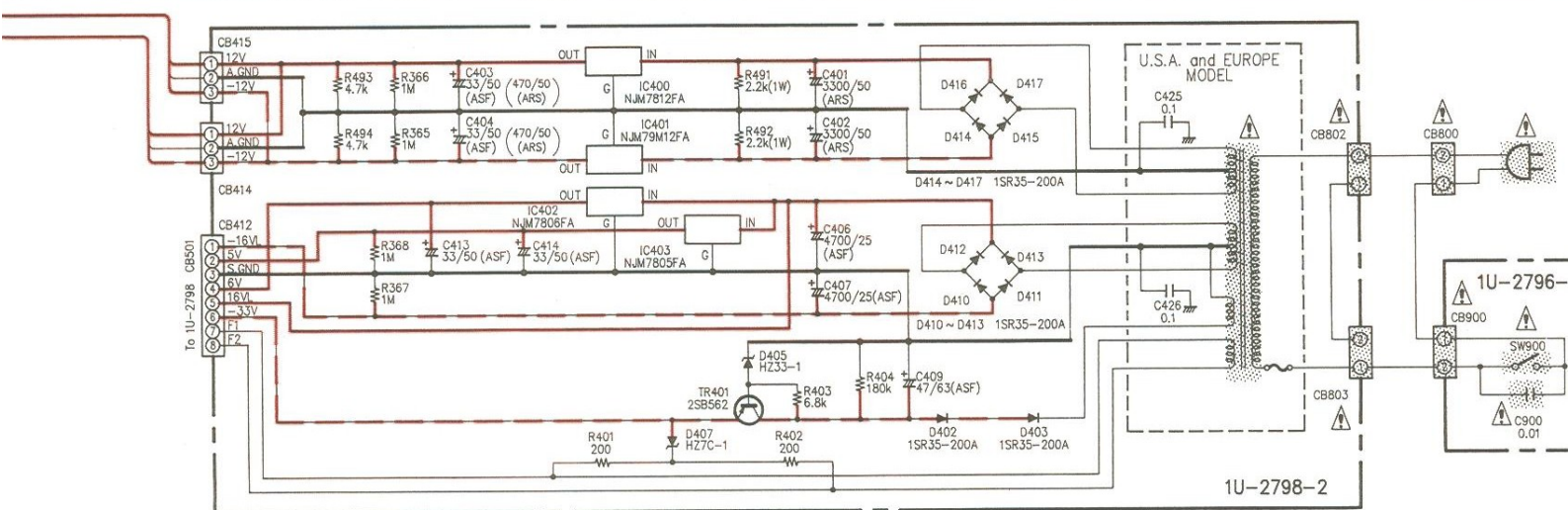
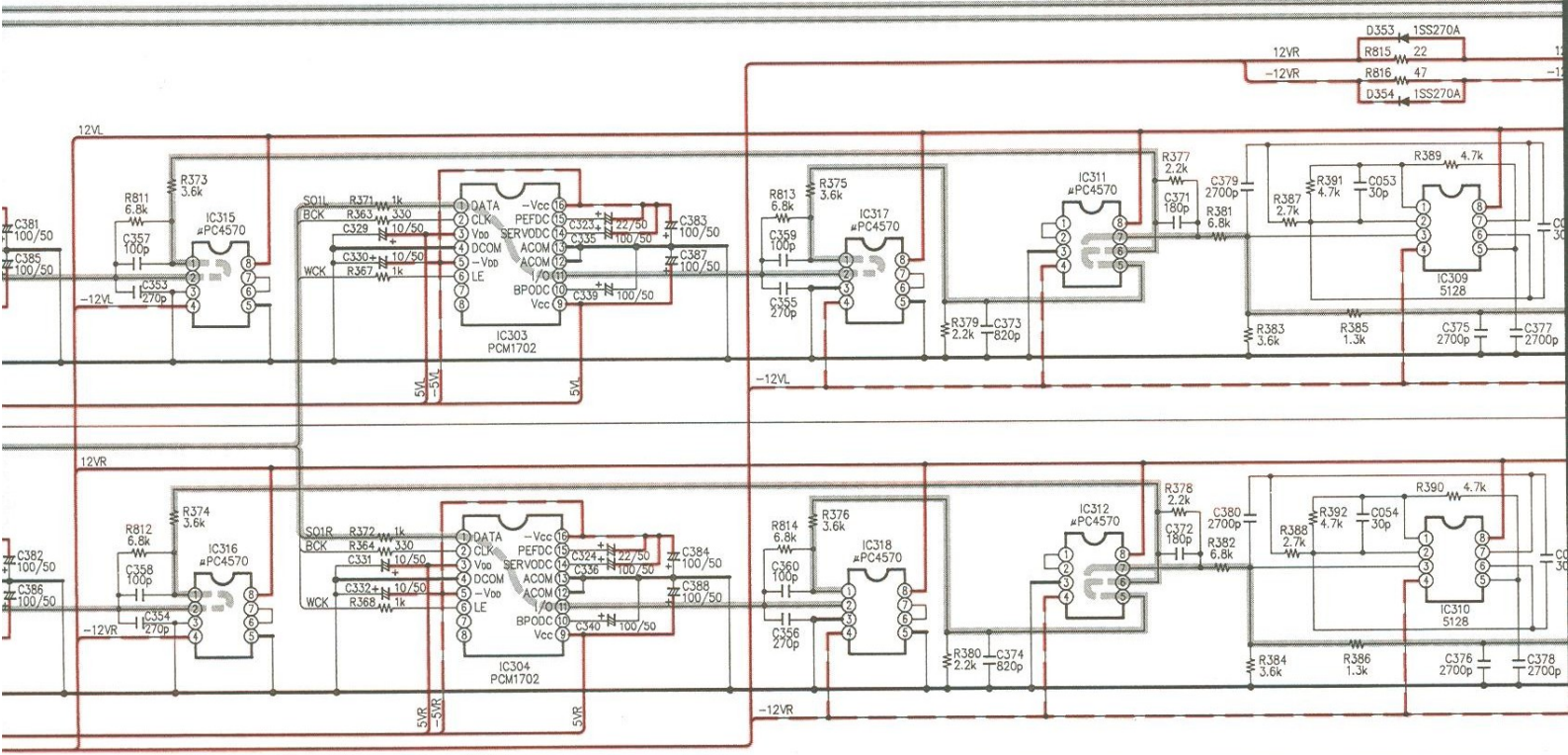
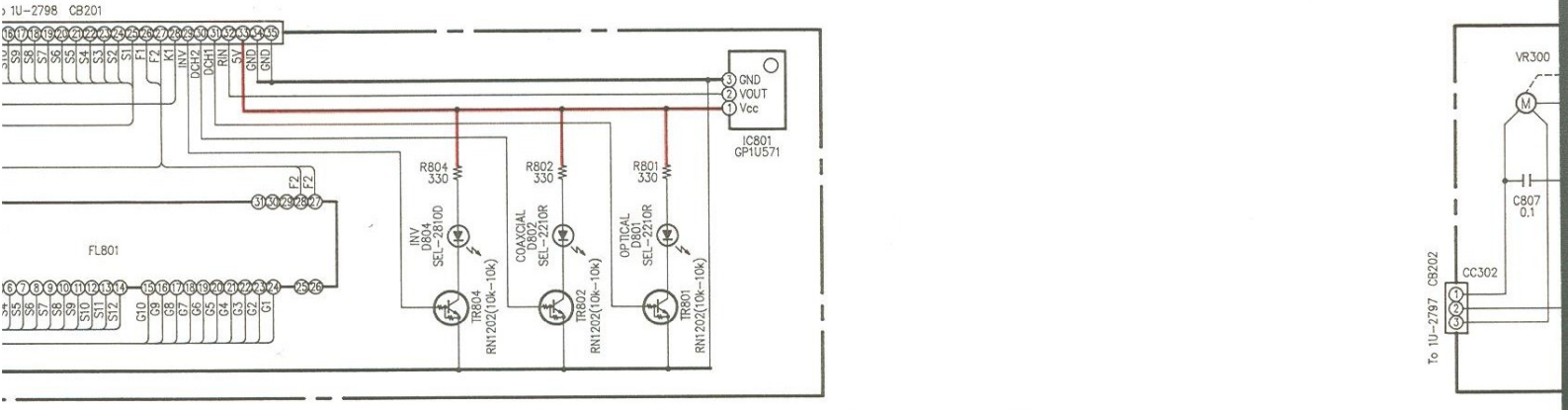

SCHEMATIC DIAGRAM-3/3

1

2

3

4

