

## SERVICE MANUAL

# MODEL DCD-500AE

### CD PLAYER

#### 注 意

サービスをおこなう前に、このサービスマニュアルを必ずお読みください。本機は、火災、感電、けがなどに対する安全性を確保するために、さまざまな配慮をおこなっており、また法的には「電気用品安全法」にもとづき、所定の許可を得て製造されております。従ってサービスをおこなう際は、これらの安全性が維持されるよう、このサービスマニュアルに記載されている注意事項を必ずお守りください。

● For purposes of improvement, specifications and design are subject to change without notice.

● 本機の仕様は性能改良のため、予告なく変更することがあります。  
● 補修用性能部品の保有期間は、製造打切後8年です。

● Please use this service manual with referring to the operating instructions without fail.

● 修理の際は、必ず取扱説明書を参照の上、作業を行ってください。

● Some illustrations using in this service manual are slightly different from the actual set.

● 本文中に使用しているイラストは、説明の都合上現物と多少異なる場合があります。

# DENON

TOKYO, JAPAN  
Denon Brand Company, D&M Holdings Inc.

## SAFETY PRECAUTIONS

The following check should be performed for the continued protection of the customer and service technician.

### LEAKAGE CURRENT CHECK

Before returning the unit to the customer, make sure you make either (1) a leakage current check or (2) a line to chassis resistance check. If the leakage current exceeds 0.5 milliamps, or if the resistance from chassis to either side of the power cord is less than 460 kohms, the unit is defective.

### LASER RADIATION

Do not stare into beam or view directly with optical instruments, class 3A laser product.

**CAUTION** Please heed the points listed below during servicing and inspection.

#### ◎ Heed the cautions!

Spots requiring particular attention when servicing, such as the cabinet, parts, chassis, etc., have cautions indicated on labels or seals. Be sure to heed these cautions and the cautions indicated in the handling instructions.

#### ◎ Caution concerning electric shock!

(1) An AC voltage is impressed on this set, so touching internal metal parts when the set is energized could cause electric shock. Take care to avoid electric shock, by for example using an isolating transformer and gloves when servicing while the set is energized, unplugging the power cord when replacing parts, etc.

(2) There are high voltage parts inside. Handle with extra care when the set is energized.

#### ◎ Caution concerning disassembly and assembly!

Though great care is taken when manufacturing parts from sheet metal, there may in some rare cases be burrs on the edges of parts which could cause injury if fingers are moved across them. Use gloves to protect your hands.

#### ◎ Only use designated parts!

The set's parts have specific safety properties (fire resistance, voltage resistance, etc.). For replacement parts, be sure to use parts which have the same properties. In particular, for the important safety parts that are marked  $\triangle$  on wiring diagrams and parts lists, be sure to use the designated parts.

#### ◎ Be sure to mount parts and arrange the wires as they were originally!

For safety reasons, some parts use tape, tubes or other insulating materials, and some parts are mounted away from the surface of printed circuit boards. Care is also taken with the positions of the wires inside and clamps are used to keep wires away from heating and high voltage parts, so be sure to set everything back as it was originally.

#### ◎ Inspect for safety after servicing!

Check that all screws, parts and wires removed or disconnected for servicing have been put back in their original positions, inspect that no parts around the area that has been serviced have been negatively affected, conduct an insulation check on the external metal connectors and between the blades of the power plug, and otherwise check that safety is ensured.

(Insulation check procedure)

Unplug the power cord from the power outlet, disconnect the antenna, plugs, etc., and turn the power switch on. Using a 500V insulation resistance tester, check that the insulation resistance between the terminals of the power plug and the externally exposed metal parts (antenna terminal, headphones terminal, microphone terminal, input terminal, etc.) is 1M $\Omega$  or greater. If it is less, the set must be inspected and repaired.

### CAUTION Concerning important safety parts

Many of the electric and structural parts used in the set have special safety properties. In most cases these properties are difficult to distinguish by sight, and using replacement parts with higher ratings (rated power and withstand voltage) does not necessarily guarantee that safety performance will be preserved. Parts with safety properties are indicated as shown below on the wiring diagrams and parts lists in this service manual. Be sure to replace them with parts with the designated part number.

(1) Schematic diagrams ... Indicated by the  $\triangle$  mark.

(2) Parts lists ... Indicated by the  $\triangle$  mark.

Using parts other than the designated parts could result in electric shock, fires or other dangerous situations.

**注意** サービス、点検時にはつぎのことにご注意願います。

#### ◎ 注意事項をお守りください!

サービスのとき特に注意を必要とする個所についてはキャビネット、部品、シャーシなどにラベルや捺印で注意事項を表示しています。これらの注意書きおよび取扱説明書などの注意事項を必ずお守りください。

#### ◎ 感電に注意!

(1) このセットは、交流電圧が印加されていますので通電時に内部金属部に触れると感電することがあります。従って通電サービス時には、絶縁トランスの使用や手袋の着用、部品交換には、電源プラグを抜くなどして感電にご注意ください。

(2) 内部には高電圧の部分がありますので、通電時の取扱には十分ご注意ください。

#### ◎ 分解、組み立て作業時のご注意!

板金部品の端面の『バリ』は、部品製造時に充分管理をしておりますが、板金端面は鋭利となっている箇所がありますので、部品端面に触れたまま指を動かすとまれに怪我をする場合がありますので十分注意して作業して下さい。手の保護のために手袋を着用してください。

#### ◎ 指定部品の使用!

セットの部品は難燃性や耐電圧など安全上の特性を持ったものとなっています。従って交換部品は、使用されていたものと同じ特性の部品を使用してください。特に配線図、部品表に  $\triangle$  印で指定されている安全上重要な部品は必ず指定のものをご使用ください。

#### ◎ 部品の取付けや配線の引きまわしは、元どおりに!

安全上、テープやチューブなどの絶縁材料を使用したり、プリント基板から浮かして取付けた部品があります。また内部配線は引きまわしやクランプによって発熱部品や高圧部品に接近しないように配慮されていますので、これらは必ず元どおりにしてください。

#### ◎ サービス後は安全点検を!

サービスのために取り外したねじ、部品、配線などが元どおりになっているか、またサービスした個所の周辺を劣化させてしまったところがないかなどを点検し、外部金属端子部と、電源プラグの刃の間の絶縁チェックをおこなうなど、安全性が確保されていることを確認してください。

(絶縁チェックの方法)

電源コンセントから電源プラグを抜き、アンテナやプラグなどを外し、電源スイッチを入れます。500V 絶縁抵抗計を用いて、電源プラグのそれぞれの端子と外部露出金属部 [アンテナ端子、ヘッドホン端子マイク端子、入力端子など] との間で、絶縁抵抗値が 1 M $\Omega$  以上であること、この値以下のときはセットの点検修理が必要です。

### 注意 安全上重要な部品について

本機に使用している多くの電気部品、および機構部品は安全上、特別な特性を持っています。この特性はほとんどの場合、外観では判別つきにくく、またもとの部品より高い定格(定格電力、耐圧)を持ったものを使用しても安全性が維持されるとは、限りません。安全上の特性を持った部品は、このサービスマニュアルの配線図、部品表につぎのように表示していますので必ず指定されている部品番号のものを使用願います。

(1) 配線図...  $\triangle$ マークで表示しています。

(2) 部品表...  $\triangle$ マークで表示しています。

指定された部品と異なるものを使用した場合には、感電、火災などの危険を生じる恐れがあります。

## DISASSEMBLY

(Follow the procedure below in reverse order when reassembling.)

### 1. Top Cover

- (1) Remove 4 screws ① on both sides.
- (2) Remove 5 screws ② on rear side.
- (3) Detach the Top cover as shown in the fig.

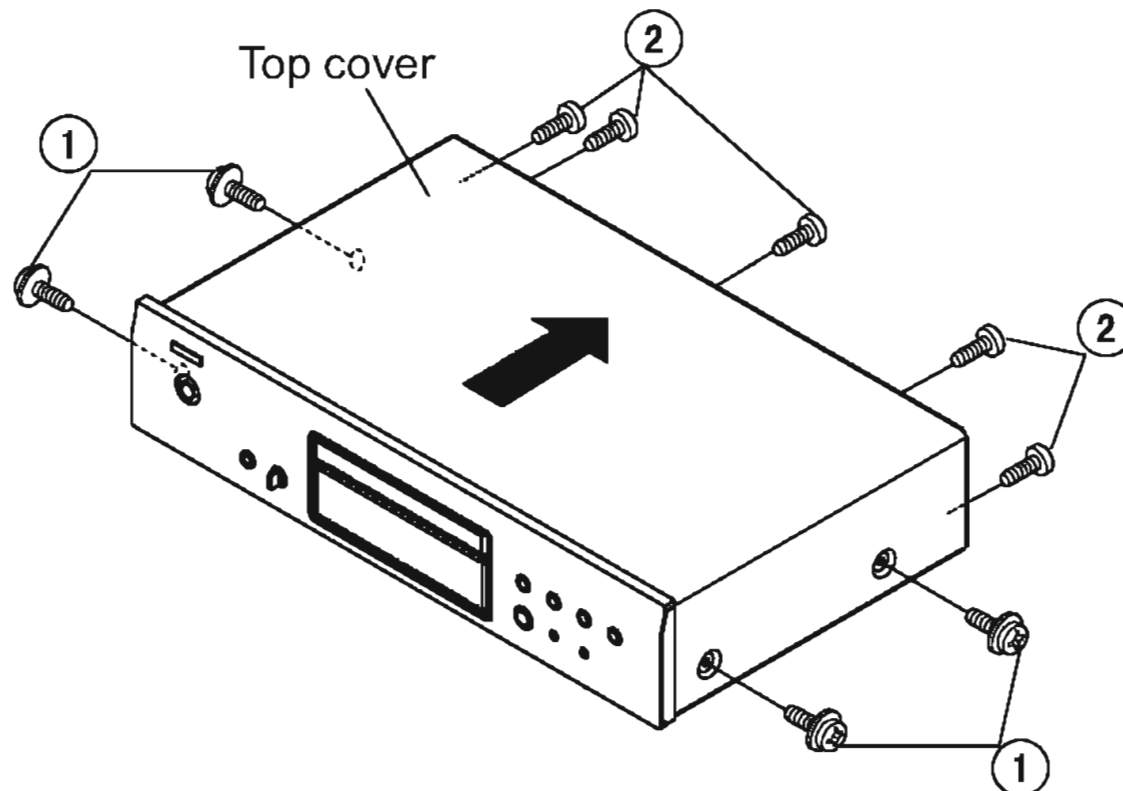

### 2. Front Panel

- (1) Take off the Chucking plate after removing 2 screws ③. Open the CD tray by turning the Drive gear (a) clockwise, then detach the Loader panel.
- (2) Remove 1 screw ④ fixing the Ring wire.
- (3) Remove 4 screws ⑤ on the bottom edge of the Front panel.
- (4) Remove 2 screws ⑥, at L/R ends of the Front panel.
- (5) Detach the Front panel.

Note : Do not yet exclude FFC( ☆ mark).

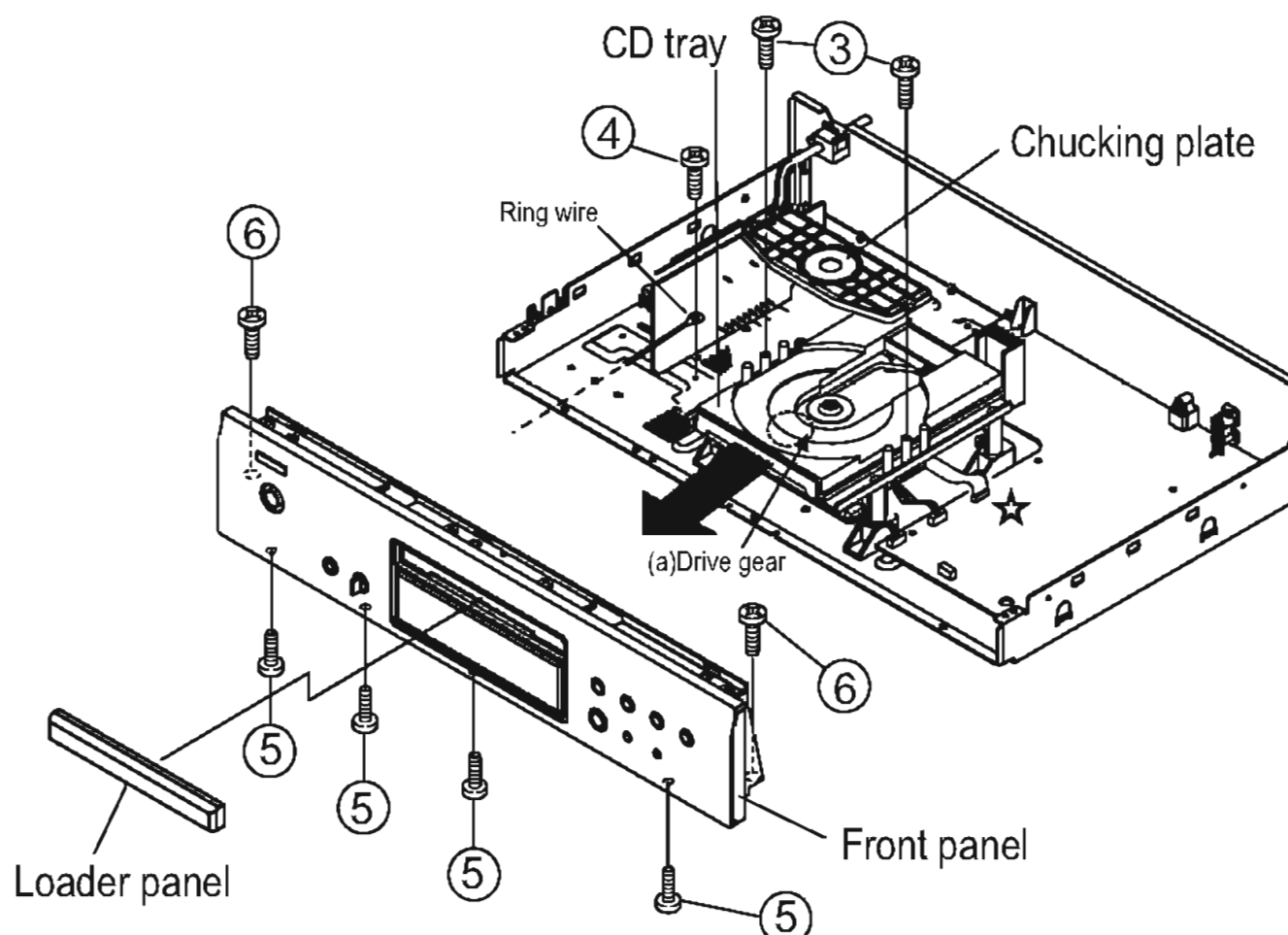

## 各部のはずしかた

(組み立てるときは、逆の順序でおこなってください。)

### 1. トップカバーのはずしかた

- (1) 側面のねじ① 4本をはずします。
- (2) 後面のねじ② 5本をはずします。
- (3) トップカバーを矢印の方向へはずします。

### 2. フロントパネルのはずしかた

- (1) ねじ③ 2本をはずしチャッキングプレートをはずします。ドライブギア (a) を時計回りに廻して CD トレイを引き出して、ローダーパネルをはずします。
  - (2) リングワイヤーを止めているねじ④ 1本をはずします。
  - (3) フロントパネル底部のねじ⑤ 4本をはずします。
  - (4) フロントパネル左右側部のねじ⑥ 2本をはずします。
  - (5) フロントパネルをはずします。
- (注) まだ FFC( ☆マーク) は抜かないこと。

### 3. CD Mecha. Unit

- (1) Remove 4 screws ⑦ fixing the CD Mecha..
- (2) Unplug Connectors (b),(c) .  
※ Do not yet exclude FFC( ☆ mark).
- (3) Laser short-circuit in Pick-up of CD Mecha..
- (4) Unplug Connector FFC from socket.
- (5) Release the FFC from the Clamper.

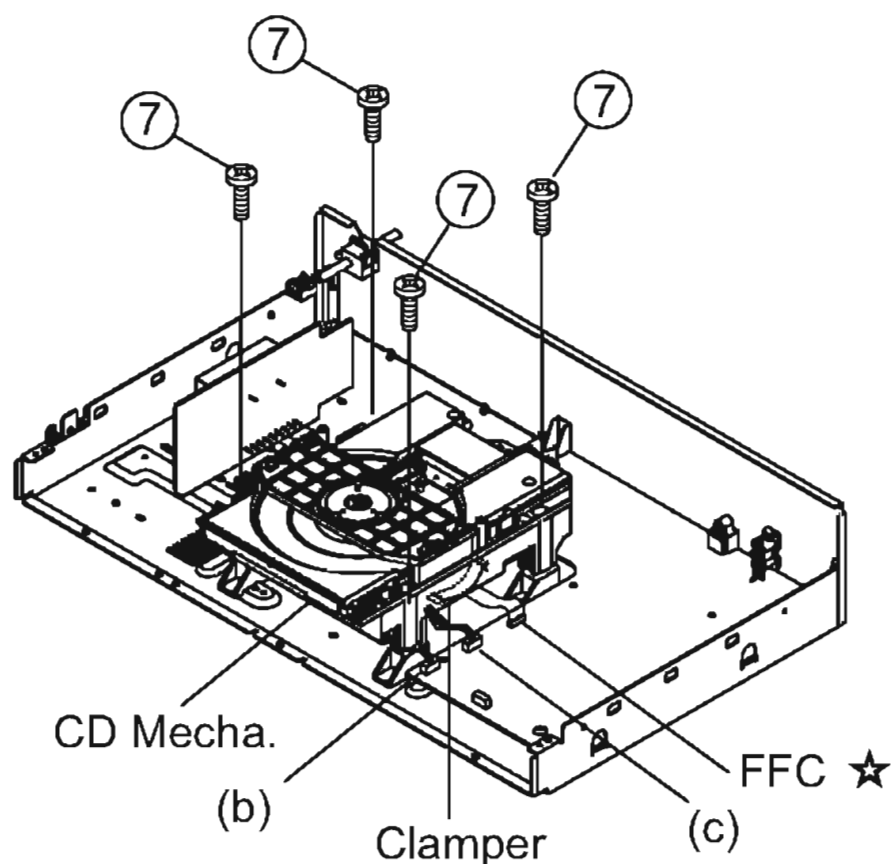

### 3. CD メカのはずしかた

- (1) CDメカを取り付けているねじ⑦4本をはずします。
- (2) コネクタ (b),(c) をソケットから抜きます。  
※まだFFCは抜かないこと(☆マーク)
- (3) ピックアップのLD回路パターンの一部を半田付けでショートします。
- (4) FFCケーブルをソケットから抜きます。
- (5) FFCケーブルをクランパーからはずします。

### 4. Main P.W.B. and Power P.W.B.

- (1) Remove 3 screws ⑧ ,1 screw ⑨~⑪ of the Rear panel and detach it.
- (2) Remove 2 screws ⑫ ,3 screws ⑬ fixing the Main P.W.B..
- (3) Remove 1 screw ⑭ ,1 screw ⑮ fixing the Power transformer with Power P.W.B..

### 4. Main 基板,Power 基板のはずしかた

- (1) リアパネルを取り付けているねじ⑧ 3本と端子を取り付けているねじ⑨~⑪各1本をはずして、リアパネルをはずします。
- (2) ねじ⑫ 2本とねじ⑬ 3本をはずして、Main 基板をはずします。
- (3) ねじ⑭ 1本とねじ⑮ 1本をはずして、Power 基板とパワートランスをはずします。

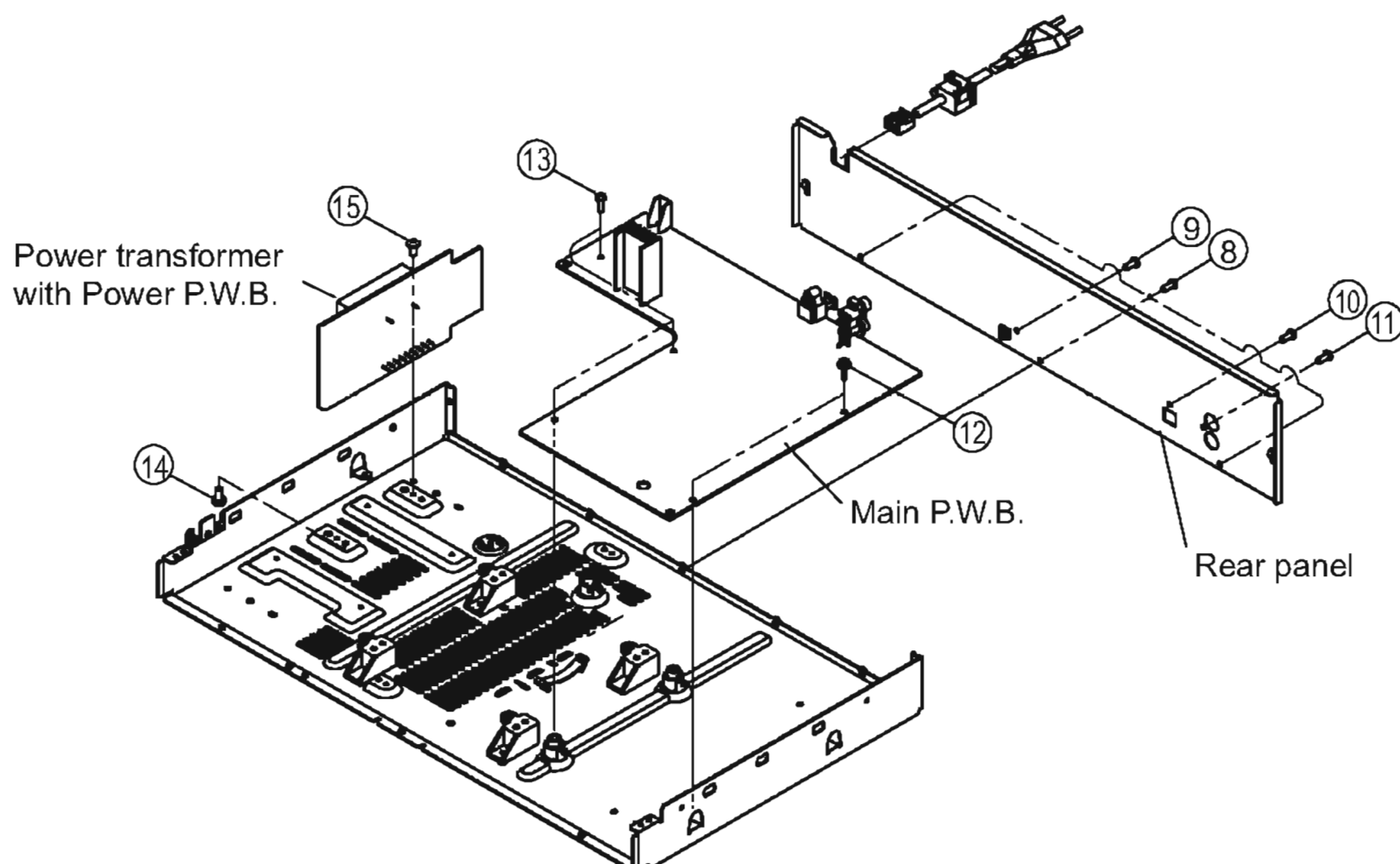

## 5 CD MECHA Ass'y

Caution: The optical pickup can be damaged by static electricity charged on human body. Take necessary anti-static measures when repairing around the optical pickup.

### 5.1 CHUCKING PLATE

- (1) Remove 2 top screw (16), then detach the Chucking plate.
- (2) Detaching the Chucking pulley and chucking yoke by removing the 3 hooks, when abandoning CD MECHA ass'y.

## 5 CD MECHA Ass'y

注意: 光ピックアップは、人体に帯電した静電気等で静電破壊することがあります。光ピックアップ周辺を修理する際には、必要な静電対策を行なってください。

### 5.1 チャッキングプレート部

- (1) CDメカのねじ (16) 2本をはずし、チャッキングプレートをはずします。
- (2) 廃棄の際は、チャッキングプーリーからチャッキングヨークのフック3箇所をはずして分離します。

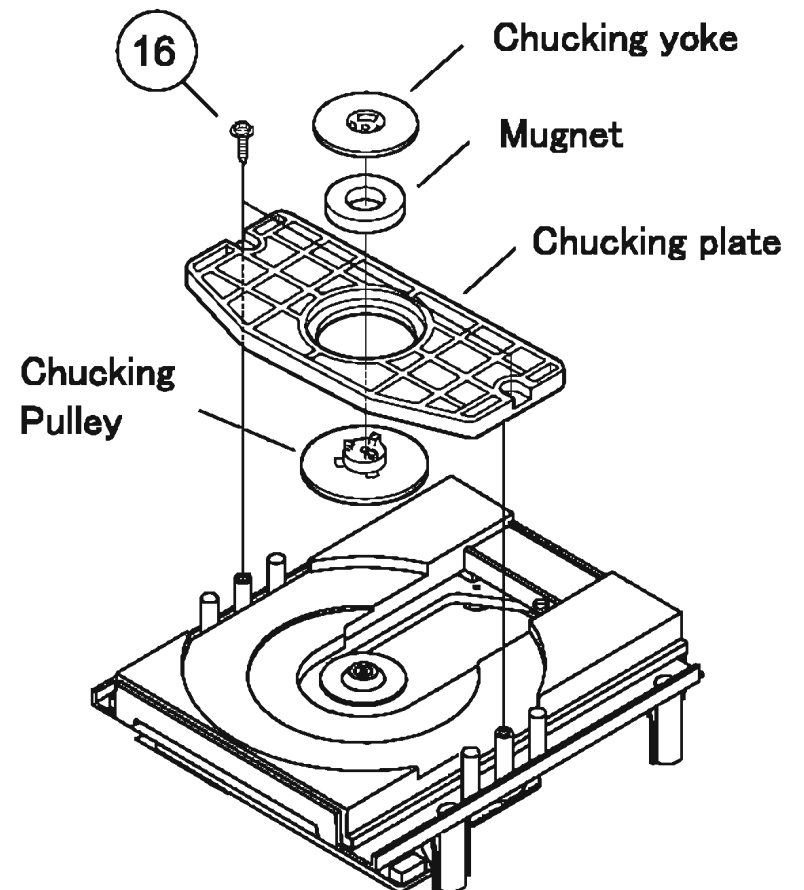

### 5.2 CD tray

When abandoning CD MECHA ass'y, please detach the CD tray.

- (1) Detach the Sw pin on the CD tray
- (2) Open the CD tray by turning the Drive gear clockwise.
- (3) Open the Stopper as shown in the fig., then detach CD tray.

### 5.2 CDトレー部

廃棄の際は、CDトレーを分離してください。

- (1) CDトレーのSw pinをはずします。
- (2) ドライブギアを時計回りに廻してCDトレーを引き出す。
- (3) ストッパーを矢印方向に開き、CDトレーをはずす。

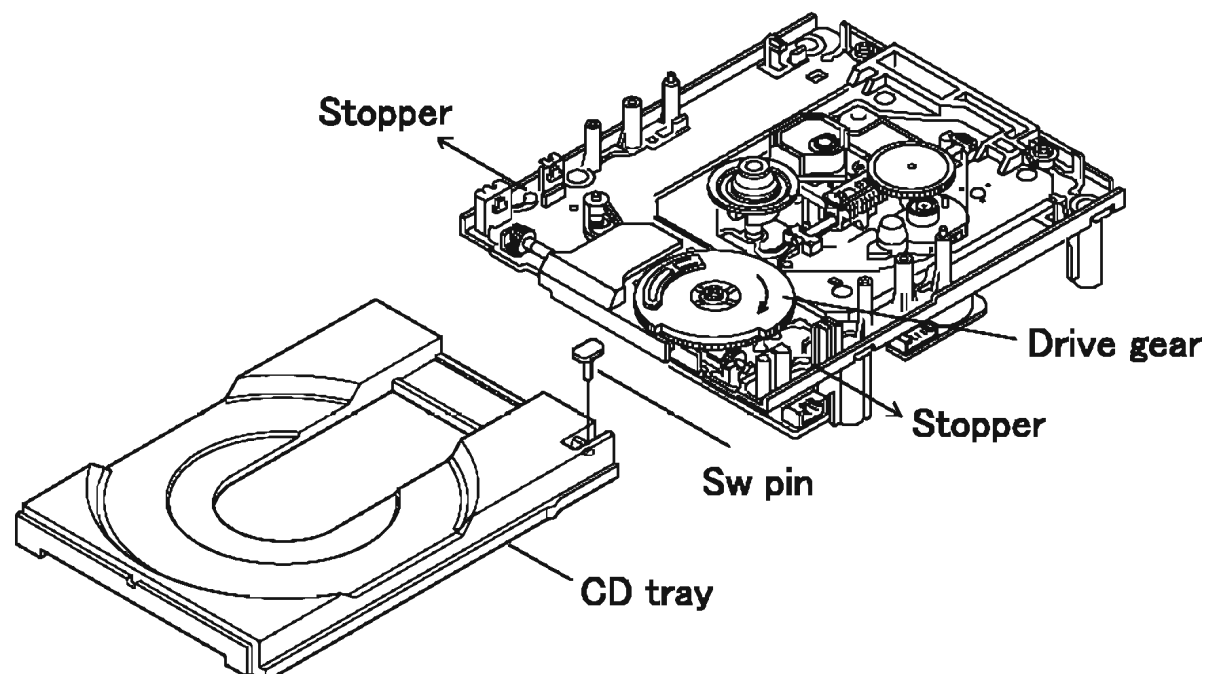

# NOTE FOR HANDLING OF LASER PICK-UP

## ● Description of the Components

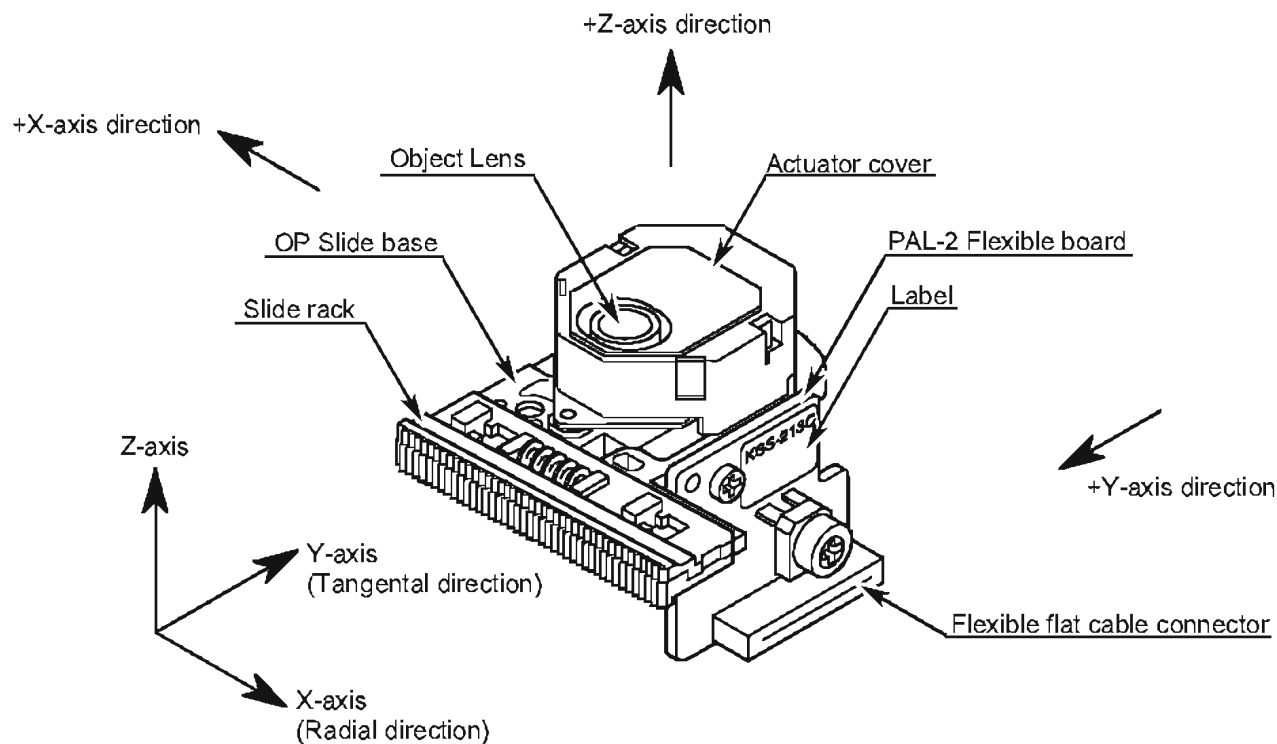

## ● Label

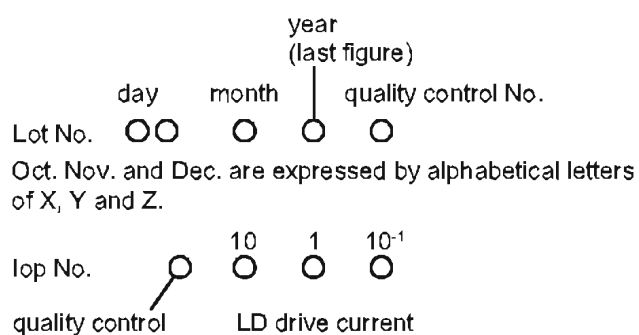
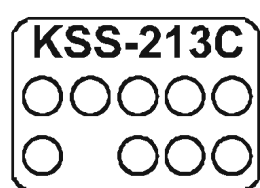

The expressed unit is by mA, with omission of the decimal point as for example, 56.5mA will be expressed as 565, but the head of English letter means the control in the manufacturing plant.

## ● Pin Connector

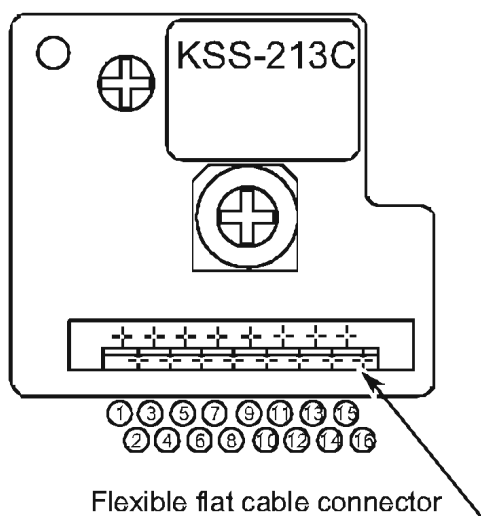

Pin No.	Description	IN/OUT	Pin No.	Description	IN/OUT
1	PD IC Vc	IN	9	LD PDIC GND	IN
2	Vcc	IN	10	LD	IN
3	E	OUT	11	VR	IN
4	D	OUT	12	PD	OUT
5	A	OUT	13	FCS (+)	IN
6	B	OUT	14	TRK (+)	IN
7	C	OUT	15	TRK (-)	IN
8	F	OUT	16	FCS (-)	IN

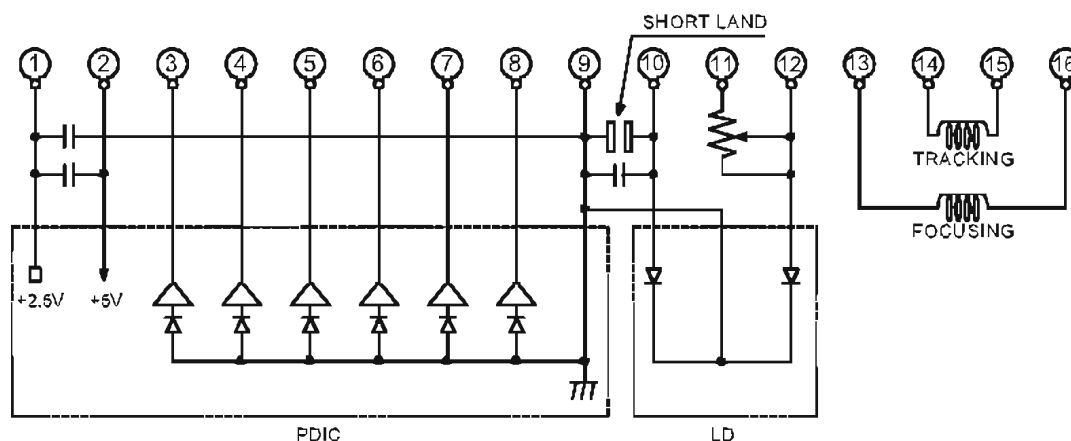

● **CAUTION:** The soldered connecting portion must be bridged when removing CN54.

レーザピックアップ取扱い上の注意  
各部の名称

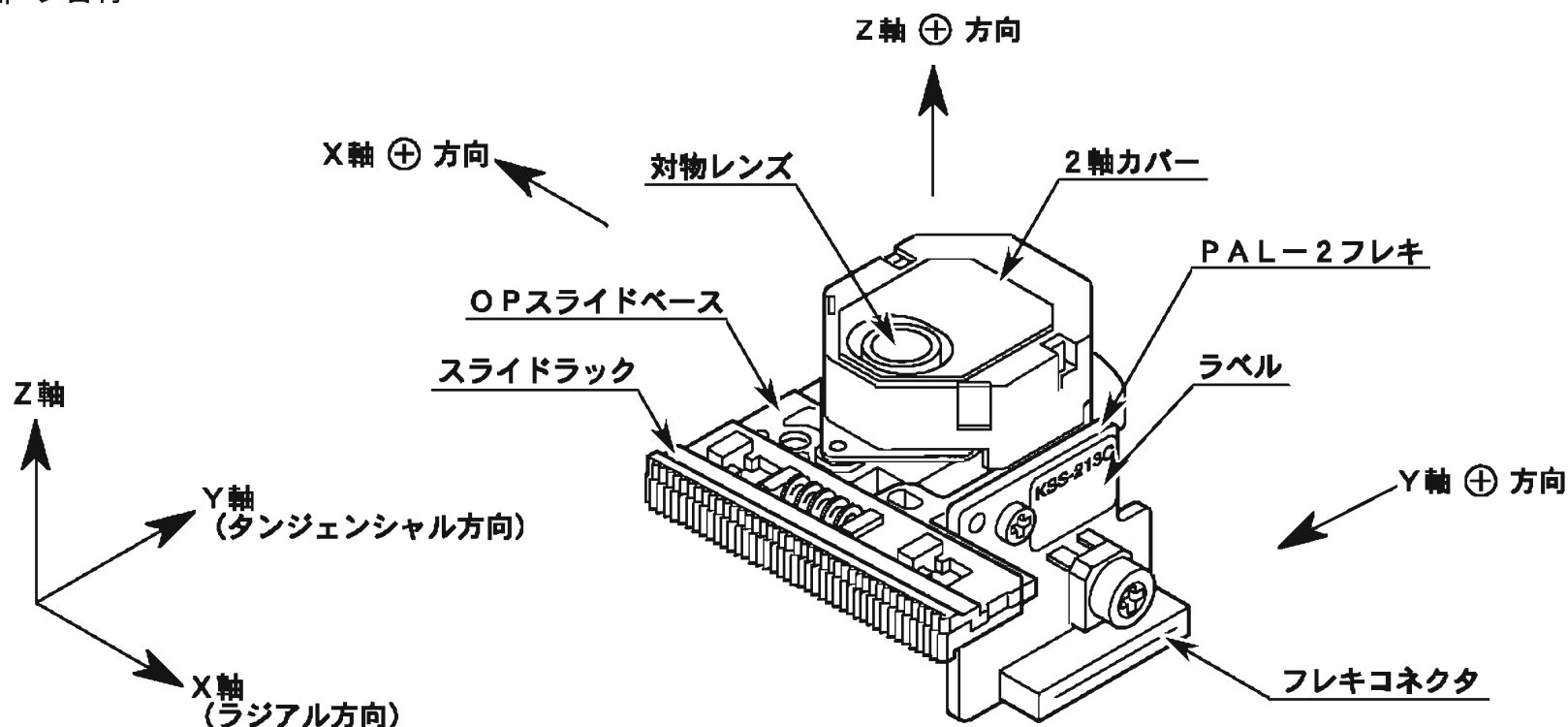

ラベル表示

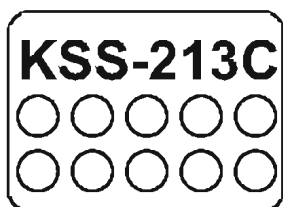

上段 日付 月 西暦年号の末尾 品質管理No.  
Lot No. ○○ ○ ○ ○ ○ ○

但し、月表示の10、11、12はX、Y、Zで表わす。

下段 英字 10桁 1桁 小数点以下第1位  
○○ ○ ○ ○

IOP表示

表示単位はmA、小数点は省略

頭の英字は、製造所の管理に用いる場合がある。但し、桁数は0~2桁迄とする。

コネクタ結線図

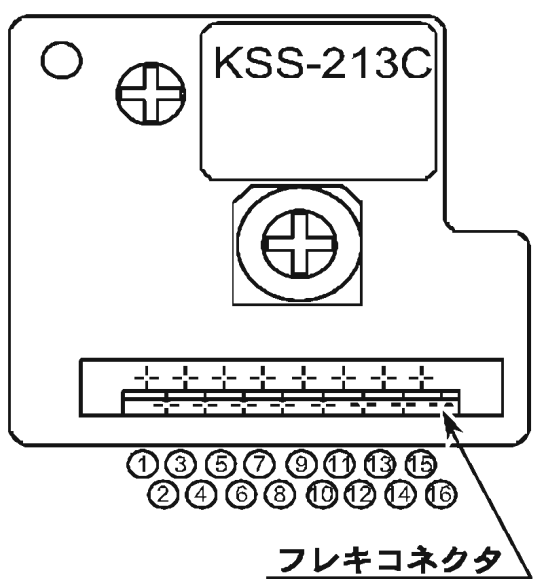

ピン No.	端子名	入出力	ピン No.	端子名	入出力
①	PD IC Vc	IN	⑨	LD PDIC GND	IN
②	Vcc	IN	⑩	LD LD	IN
③	E	OUT	⑪	VR	IN
④	D	OUT	⑫	PD	OUT
⑤	A	OUT	⑬	FCS (+)	IN
⑥	B	OUT	⑭	TRK (+)	IN
⑦	C	OUT	⑮	TRK (-)	IN
⑧	F	OUT	⑯	FCS (-)	IN

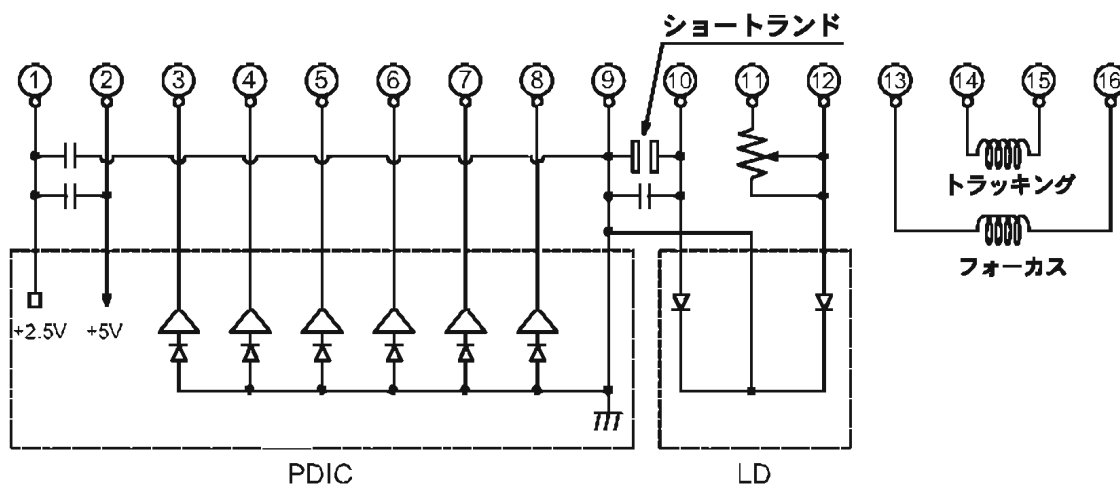

(注意) CN54 (16P FFC ケーブル) をはずす前にハンダ接続部(ショートランド)をブリッジしてください。

## ● Caution for Handling the Laser Pick-up

The laser pick-up KSS-213C is assembled and precisely adjusted using a sophisticated manufacturing process in our plant. Do not disassemble or attempt to readjust it. Please observe the following instructions carefully in handling the pick-up.

### 1. Handle with Care

- (1) Storage  
Do not store the pick-up in dusty, 0 or high-humidity environments.
- (2) Please take care for preventing from shock by falling down or careless handling.

### 2. Laser Diode (LD)

- (1) Protect your eyes  
The laser beam may damage the human eye, since the intensity of the focused spot may reach  $7 \times 10^3$  W/cm<sup>2</sup> even if the intensity at the objective lens is 400μW maximum. As the light beam spreads after focused through the objective lens, it does not effect you in the place as far as more than 30 cms. However, do not look at the laser light beam either through the objective lens directly nor another lens or a mirror.
- (2) Poison of As  
Since the LD chip contains As (Arsenic), as GaAs + GaAlAs, as known as the poison, although the poison is relatively weak, in comparing with others, e.g. As<sub>2</sub>O<sub>3</sub>, AsCl<sub>3</sub> etc., and the amount is small, avoid putting the chip in acid or an alkali solution, heating it over 200 °C or putting it into your mouth.
- (3) Avoid surge current or electrostatic discharge  
The LD may be damaged or deteriorated by its own strong light if a large current is supplied to it, even if only a short pulse.  
Make sure that there is no surge current in the LD driving circuit by switches or else. Be careful to handle pick-up as it may be damaged in a moment by human electrostatic discharge. The pins of the LD are short-circuited by solder for protection during shipment.  
For safety handling of an LD, grounding the human body, measuring equipments and jig is strongly recommended. And still it is further desirable to make use of mat on the platform and floor for handling the LD.  
To open the short-circuit, remove the soldering quickly with a soldering iron whose metal part is grounded.  
The temperature of the soldering iron should be less than 320°C (30W).

### 3. Actuator

- (1) The performance of the actuator may be affected if magnetic material is located nearby, since the actuator has a strong magnetic circuit. Do not permit dust to enter through the clearance of the cover.
- (2) Cleaning the lens  
It may change the specifications by attaching dust or ash on the objective lens. Clean the lens with a cleaning paper dampened with, not pressing lens with so much strength by the cleaning paper.

### 4. Metal Bearing

As the metal bearing of Cu-compound sintered alloy is impregnated with FROIL946P, never fail to supply the bushing with the same lubricant at the time of replacing the pick-up.

### 5. Handling

Please handle the laser pick-up with holding the slide base. (resin molded part).  
When either a part of human body or some other things may happen to touch directly with the circuit part of P.W.Board, it may cause deterioration, take careful attention in handling this base.

### 6. Deterioration

As KSS-213C comprises built-in RF Amp and APC circuit, resists stronger against external electrostatic damages than the former typed pickup. However, there is possibility of pickup deterioration in the following cases.

- (1) Low HF level, or with great numbers of jitters.
- (2) Tracking offset (EF Balance) is out of order (Refer to "Confirmation Method of Adjustment" for confirmation (1) and (2)).



## 取扱い上の注意事項

レーザーピックアップKSS-213Cは専門工場にて精密に組立調整されております。  
安易に分解、調整等を行わないでください。取扱いに関して次の点に注意してください。

### 1. 一般事項

#### (1) 保管

高温高湿下、ほこりの多い所での保存はさけてください。

(2) 精密に調整されていますので落下や不用意な取扱いによる衝撃がかからない様に注意してください。

### 2. 半導体レーザー (LD)

#### (1) レーザー光に対する目の保護

LDの出力は対物レンズ射出出力で最大400 Wですが集光された所では約 $7 \times 10^3 \text{ W/cm}^2$ に達します。対物レンズ集光後は光束が広がりますので30cm以上離れば大丈夫ですが動作中のLDを直視したり、あるいは他のレンズやミラーを介して光束を観察すると危険ですから絶対に行わないでください。

#### (2) Asの毒性

LDのチップはGaAs + GaAlAsで毒物として良く知られているAsを含んでいます。

毒性は他の化合物、例えば $\text{As}_2\text{O}_3$ 、 $\text{AsCl}_3$ 等に比較し、はるかに弱い毒性で素子1ヶ当たりは少量ですのでほとんど問題ありませんが、チップを取り出し、酸やアルカリ溶液へ入れたり、200℃以上に加熱したり、口に入れたりすることは絶対に行わないでください。

#### (3) サージ電流、静電気による破壊

LDに大電流を流すときわめて短時間であっても自身が発する強い光によって劣化が促進され、或は破壊します。

LD駆動回路にはスイッチ、その他によるサージ電流が流れない様にしてください。又、不注意に取り扱おうと人体からの静電気が加わって瞬時に破壊されてしまいます。

LDの端子は出荷時に輸送による静電気破壊防止の為半田でショートされています。

更に、安全を期するため、取付時人体アース、計測器及び治工具のアースを必ず行ってください。又作業台、床にはアースマットを用いて接地してください。

ショート部の開放はLDコネクタ差し込み後、半田ゴテで行ってください。半田ゴテは金属部分が接地されたものを使用してください。

半田ゴテ先温度は320℃以下(30W)のものを使用し、すみやかに行ってください。

### 3. 2軸アクチュエータ

(1) アクチュエータ部は強力な磁気回路を有していますので磁性体が近づくと特性が変化します。

又、カバーのすきまから異物が入ることの無い様にしてください。

#### (2) レンズ清掃

対物レンズにゴミ、ホコリ等の汚れがついたとき性能が変化します。

清掃に当たってはレンズペーパーに水を少量つけ無理な力がレンズに加わらない様に拭いてください。

### 4. 軸受

軸受けにはフロイル946P(関東化成工業)を塗布して有りますので、ピックアップ交換時は、必ずフロイル946Pを塗布してください。

### 5. 取扱い

光学ピックアップの取扱いはスライドベース(樹脂モールド部)を持って行ってください。プリント基板の回路部に人体、又は他の物体が直接接触すると劣化の原因になることが有りますので、充分ご注意ください。

### 6. レーザーピックアップの劣化

トラッキング及びフォーカス調整が困難になったり、まったく不可能となった場合には、レーザーピックアップの劣化が考えられます。この場合はレーザーダイオードの電流値を測定して判定を行ってください。

## HEAT RUN MODE

No	Mode	Operation and Function	Display
1	Heat Run Mode	<p>① When DISC is attached, POWER switch is turned to ON while pressing the Stop (■) button on Main Unit. "DCD500DNC100" is displayed.</p> <p>② Press the Skip (▶▶▶) button continuously for over 3 seconds to display the version number of main micro computer.</p> <p>③ While the version number of main micro computer is displayed, press the Play/Pause (▶/  ) button continuously for over 3 seconds to start heat run. ▶ is lit,    is flashing and the other part of the FL tube is displayed in the same way as normal play mode. Count this as the 0th heat run repetition.</p> <p>1) Play from the first to last track on disc. 2) After disc playback has finished, pickup is moved to innermost position. 3) The tray is opened and the heat run repetition number is incremented (increased by 1). 4) The tray is closed. 5) TOC is re-read. Conduct 1) to 5) repeatedly.</p> <ul style="list-style-type: none"> <li>If the TIME button is pressed while operating, number of heat run is displayed for 1 second.</li> <li>While heat run, the operation of each button is not valid except the TIME button.</li> <li>POWER switch is turned to OFF to clear heat run mode.</li> <li>If an error occurs, display the error and stop operation at that point. Number of operations held.</li> </ul>	<p>▶ "DCD500DNC100"</p> <p>XX - XXXX - XX</p> <p>xx-xxxx-xx : The version number of main micro computer</p> <p>▶ " XX mm : SS</p> <p>xx : Number of music being played mm:ss : Elapsed time of music being played</p> <p>▶ "CD XXXX</p> <p>xxxx : Number of heat run repetition</p> <p>Ex - 00</p> <p>Error Code      Content</p> <p>E1-00      Disc cannot be detected.</p> <p>E2-00      Focus servo could not follow during playback.</p> <p>E3-00      TOC could not be read within specified time.</p>
2	Number of Heat Run Repetition Display Mode	Press the Skip (▶▶▶) button while the error is displayed. ▶ and    are lit. And number of heat run repetition is displayed for 5 second and then the error display reappears.	<p>▶ "CD XXXX</p> <p>xxxx : Number of heat run repetition</p>
3	Number of Track and Elapsed Time of Track being played Display Mode	Press the Skip (▶▶▶) button while the error is displayed. ▶ and    are lit. And Number of track and elapsed time of track being played in time when error occurred are displayed for 5 second and then the error display reappears.	<p>▶ " XX mm : SS</p> <p>xx : Number of track in time when error occurred mm:ss : Elapsed time of track being played in time when error occurred</p>

## ヒートランモード

No	モード	操作と機能	表示
1	ヒートランモード	<p>① DISC をセットした状態で本体の Stop (■) ボタンを押しながら、POWER スイッチを ON にします。モデル名 DCD500DNC100 を表示します。</p> <p>② Skip (▶▶▶) ボタンを 3 秒以上押し、マイコンのバージョン番号を表示させます。</p> <p>③ マイコンのバージョンが表示されている間に Play/Pause (▶/  ) ボタンを 3 秒以上押し、ヒートランを開始します。▶ が点灯、   が点滅します。他は通常再生モードと同じです。</p> <p>以下の動作を繰り返し行います。最初のヒートラン回数を 0 回目とします。</p> <p>1) ディスクの先頭曲から最終曲までを再生します。 2) ディスクの最終曲再生終了後、PU を再内周に移動させます。 3) トレーをオープンし、ヒートラン回数をカウントアップします。 4) トレーをクローズします。 5) TOC リードを行い、1) の動作から再度開始します。</p> <ul style="list-style-type: none"> <li>ヒートラン動作中に TIME ボタンを押すと、1 秒間ヒートラン回数が表示されます。</li> <li>ヒートラン時は TIME ボタン以外受け付けません。</li> <li>ヒートランモードを解除するときは、POWER スイッチを OFF にします。</li> <li>ヒートラン動作中にエラーが発生すると、エラーを表示し、その時の状態で停止します。動作回数は保持されます。</li> </ul>	<p>▶ "DCD500DNC100"</p> <p>XX - XXXX - XX : メインマイコンのバージョン番号</p> <p>▶ " XX mm : SS</p> <p>xx : 再生中トラック番号 mm:ss : 再生時間</p> <p>▶ "CD XXXX</p> <p>xxxx : ヒートラン回数</p> <p>▶ "CD XXXX</p> <p>xxxx : ヒートラン回数</p> <p>Ex - 00</p> <p>エラーコード      内      容</p> <p>E1-00      ディスクの検出ができない。</p> <p>E2-00      再生中にフォーカスが追従できなかった時があった。</p> <p>E3-00      TOC が規定時間内に読めない。</p>
2	エラー時のヒートラン回数表示モード	エラー表示中に Skip (▶▶▶) ボタンを押すと、▶ と    が点灯し、ヒートラン回数を 5 秒間表示して、エラー表示に戻ります。	<p>▶ "CD XXXX</p> <p>xxxx : ヒートラン回数</p>
3	エラー時の曲番と時間表示モード	エラー表示中に Skip (▶▶▶) ボタンを押すと、▶ と    が点灯し、エラー発生時の曲番と再生時間を 5 秒間表示して、エラー表示に戻ります。	<p>▶ " XX mm : SS</p> <p>xx : エラー発生時のトラック番号 mm:ss : エラー発生時の再生時間</p>

## SERVICE MODE

No	Mode	Operation and Function	Display
1	Version Number of Micro Computer Display Mode	<p>① POWER switch is turned to ON while pressing the Stop (■) button on Main Unit.</p> <p>② Press the Skip (▶▶▶) button continuously for over 3 seconds to display the version number of main micro computer.</p>	<div style="border: 1px solid black; padding: 5px; text-align: center;">XX - XXXX - XX</div> <p>xx-xxxx-xx : The version number of main micro computer</p>
2	Number of Laser ON Time Count Display Mode	<p>① POWER switch is turned to ON while pressing the Stop (■) button on Main Unit.</p> <p>② Press the Skip (◀◀◀) button continuously for over 3 seconds to display number of Laser ON time count.</p> <p>• The number of time when the normal playback time the Laser is turned to ON is incremented (increased by 1) in every 15 minutes. The accumulation number of times is recorded to memory whenever count it.</p>	<div style="border: 1px solid black; padding: 5px; text-align: center;">LD - xxxx</div> <p>xxxx : Number of Laser ON time count</p>
3	Initialize Mode	<p>POWER switch is turned to ON while pressing the TIME button on Main Unit.</p> <ul style="list-style-type: none"> <li>• Brightness setting of display becomes 100% (default).</li> <li>• The accumulation number of laser on time is cleared, and a count becomes 0000.</li> </ul>	Not special display

## サービスモード

No	モード	操作と機能	表示
1	マイコンのバージョン番号表示モード	<p>①本体の Stop (■) ボタンを押しながら、POWER スイッチを ON にします。</p> <p>② Skip (▶▶▶) ボタンを 3 秒以上押し、マイコンのバージョン番号を表示させます。</p>	<div style="border: 1px solid black; padding: 5px; text-align: center;">XX - XXXX - XX</div> <p>xx-xxxx-xx : メインマイコンのバージョン番号</p>
2	レーザー ON 時間カウント回数表示モード	<p>①本体の Stop (■) ボタンを押しながら、POWER スイッチを ON にします。</p> <p>② Skip (◀◀◀) ボタンを 3 秒以上押し、レーザー ON 時間カウント回数を表示させます。</p> <p>• 通常再生時にレーザーを ON にしている時間を 15 分毎にカウントアップします。カウント時に累積回数を記憶します。</p>	<div style="border: 1px solid black; padding: 5px; text-align: center;">LD - xxxx</div> <p>xxxx : レーザー ON 時間カウント回数</p>
3	初期化モード	<p>本体 TIME ボタンを押しながら、POWER スイッチを ON にします。</p> <ul style="list-style-type: none"> <li>• FL 管の輝度設定を 100% (デフォルト) にします。</li> <li>• レーザー ON 時間カウントの累積回数をクリアします。</li> </ul>	なし

# CD TEST MODE & SERVICE MODE

## 1. Firmware Version confirmation method and Test Mode approach method.

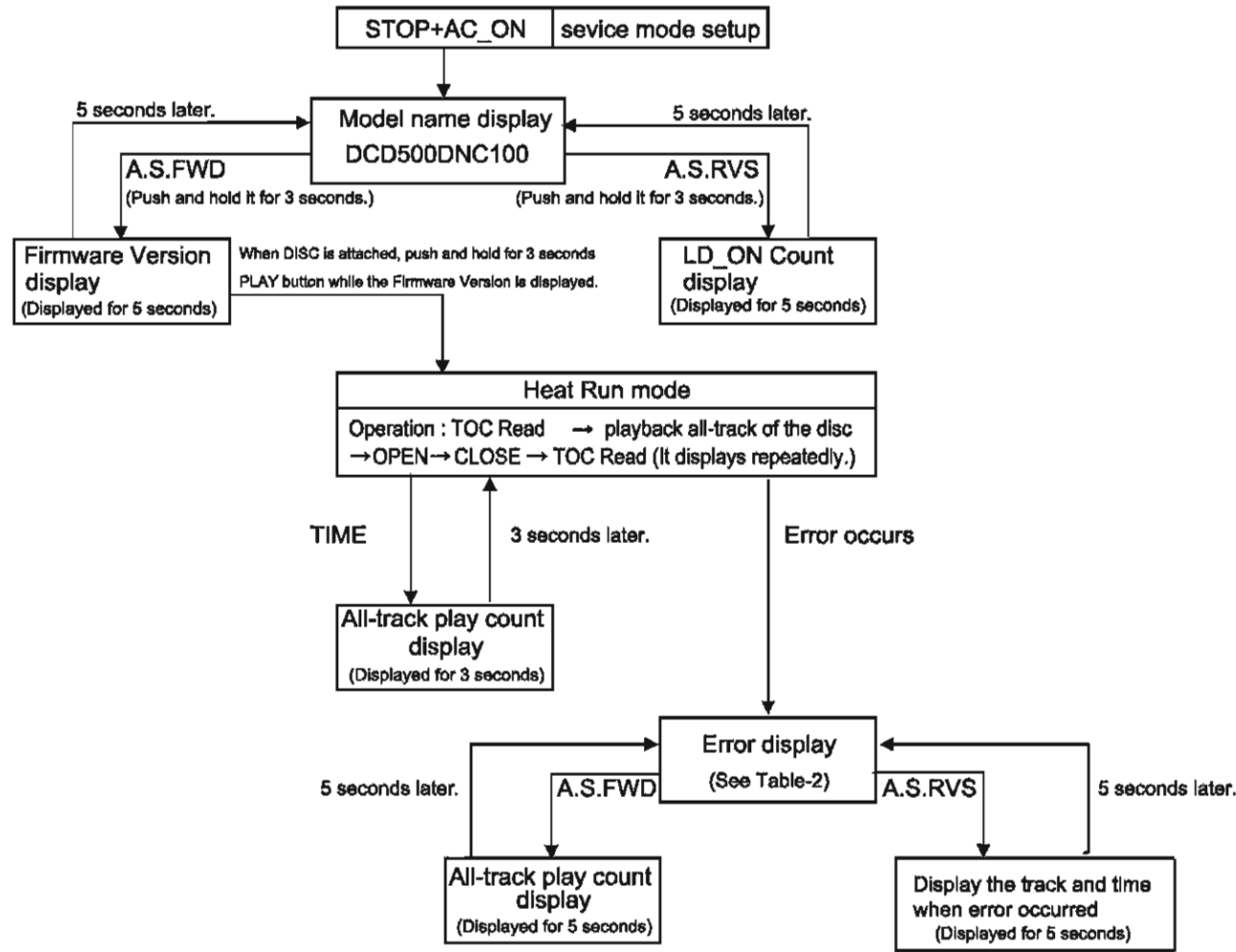

## 2. Error Code Table

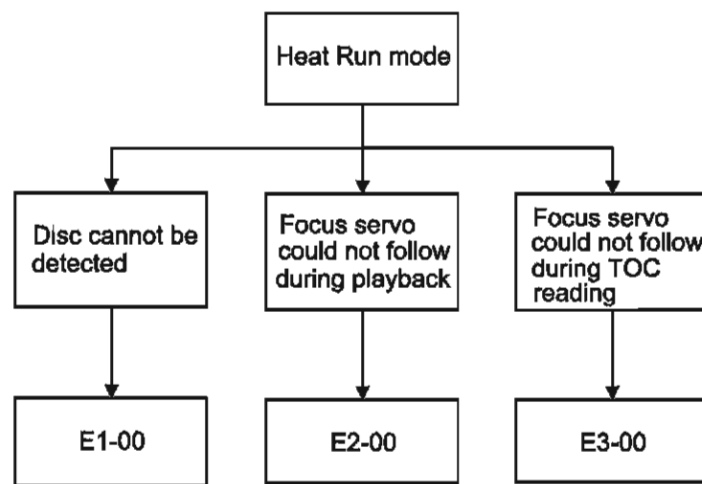

## 1. Firmware Version確認方法及びTest Modeへの進入方法.

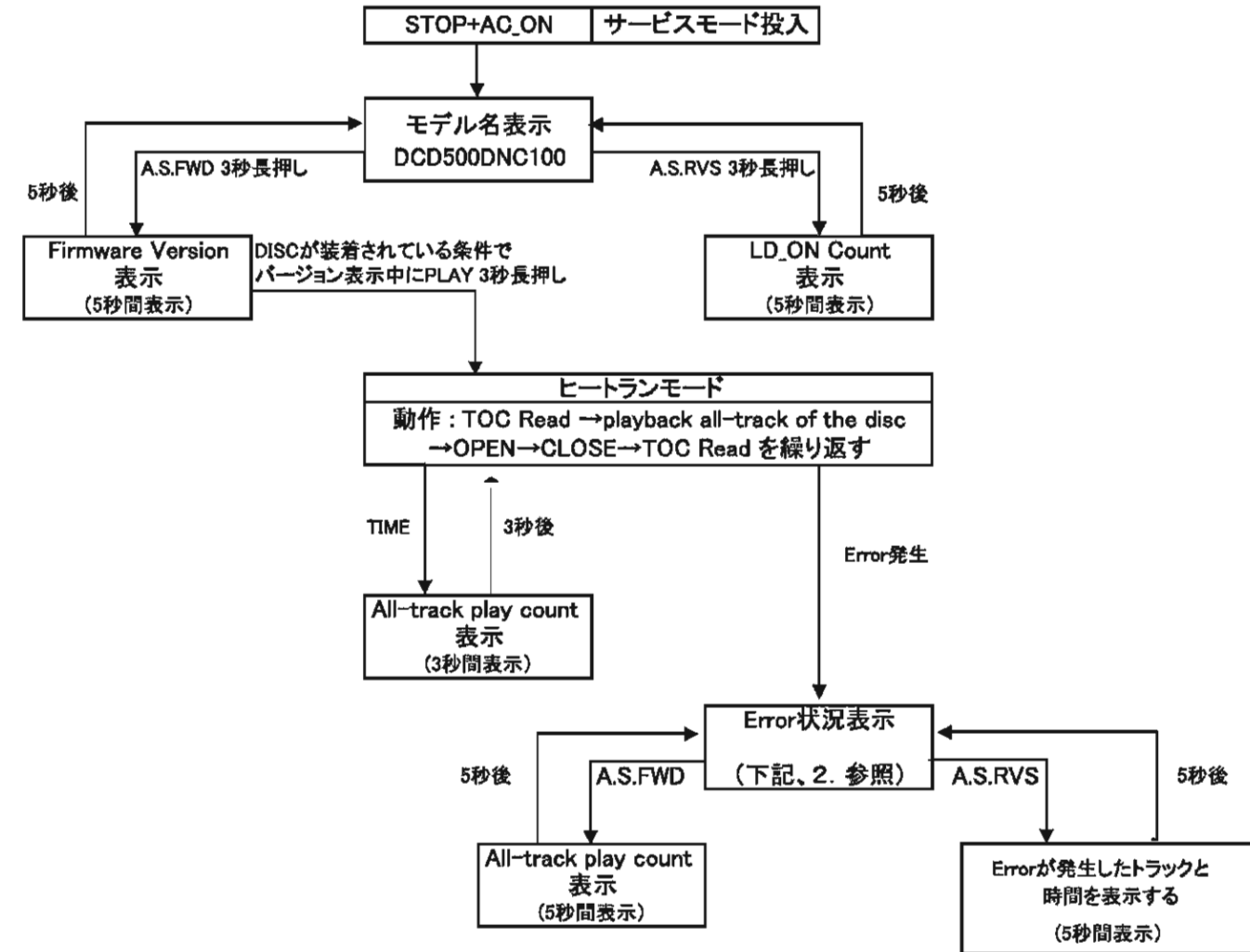

## 2. Heat run モードでのError別 FL表示管の表示.

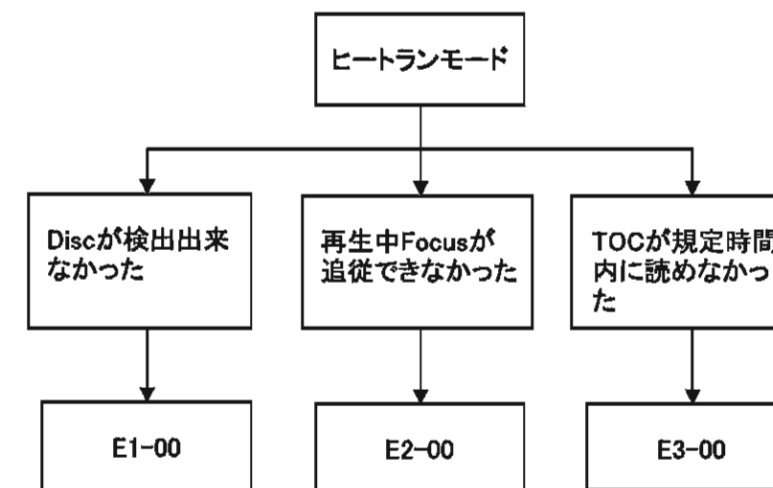

## TROUBLE SHOOTING

## FLOW CHART NO.1

The power cannot be turned on.

Is the fuse normal? → No

See FLOW CHART No.2 &lt;The fuse blows out.&gt;

↓ Yes

Is normal state restored when once unplugged power cord is plugged again after several seconds? → No

Check if there is any leak or short-circuiting on the primary circuit component, and service it if defective. (T401, D411, D412, D413, IC42)

↓ Yes

Is the ST+5V line voltage normal? → No

↓ Yes

Check each rectifying circuit of the secondary circuit and service it if defective.

## FLOW CHART NO.2

The fuse blows out.

Check the presence that the primary component is leaking or shorted and service it if defective.

Check the presence that the rectifying diode or circuit is shorted in each rectifying circuit of secondary side, and service it if defective.

After servicing, replace the fuse.

## FLOW CHART NO.3

3.3V is not outputted.

Is VCC(5V) voltage supplied to Pin(3) of IC44? → No

Is M+8V voltage supplied to Pin(2) of IC43?

↓ Yes

↓ Yes

Check IC41, L401, C426, C425, C433 and the periphery circuit, and service it if defective.

Check IC44, IC43 and the periphery circuit, and service it if defective.

## FLOW CHART NO.4

The fluorescent display tube does not light up.

Is 5V voltage supplied to Pins(13) of FL21? → No

Check the ST+5V line and service it if defective.

↓ Yes

Is the voltage of approximately -28V supplied to Pin(6) of FL21? → No

Check the VF line and service it if defective.

↓ Yes

Is the voltage of approximately -22V supplied to Pin(1)(2), (44)(45) of FL21? → No

Check the FIP1/FIP2 line and service it if defective.

↓ Yes

Check the fluorescent display tube control signal of a microcomputer. (VFD-PWR, VFD-CS, VFD-CLK, VFD-

## FLOW CHART NO.5

VF is not outputted.

Is approximately -29V voltage supplied to the anode of D402? → No

Check D402, D404 and periphery circuit, and service it if defective.

↓ Yes

Check if there is any leak or short-circuit on the loaded circuit, and service it if defective.

## FLOW CHART NO.6

The key operation is not functioning.

Are the contact point and the installation state of the key switches (S201-207) normal? → No

Re-install the switches (S201-207) correctly or replace the poor switch.

↓ Yes

When pressing each switches (S201-207), do the voltage of pin(76) of IC55 increase? → No

Check the switches (S201-207) and their periphery, and service it if defective.

↓ Yes

Replace IC55.

**FLOW CHART NO.7**

No operation is possible from the remote control unit.

Is 5V voltage supplied to Pin(3) terminal of the infrared remote control receiver (RC21)?

→No

Check ST+5V line and service it if defective.

↓ Yes

Is the "L" pulse sent out Pin(1) terminal of receiver (RC21) when the infrared remote control is activated?

→No

Replace the infrared remote control receiver (RC21) or replace the remote control unit.

↓ Yes

Is the "L" pulse supplied to the Pin(1) of IC55?

→No

Check the line between Pin(1) terminal of receiver (RC21) and Pin(1) of IC55, and service it if defective.

↓ Yes

Replace IC55.

**FLOW CHART NO.8**

The disc tray cannot be opened and closed. (It can be done using the remote control unit.)

Is the normal control voltage inputted to Pin(76) of IC55? Refer to "FLOW CHART NO.6" <The key operation is not functioning.>

→No

Replace the "OPEN" button (S207).

↓ Yes

Refer to "FLOW CHART NO.9" <The disc tray cannot be opened and closed.>

**FLOW CHART NO.9**

The disc tray cannot be opened and closed.

Check the line between CN52 and IC55, and service it if defective.

**FLOW CHART NO.10**

Audio is not outputted normally.

Set the disc on the disc tray, and playback.

Are the analog audio signals outputted to each pin(7) of IC72 or IC82  
 IC72 7PIN : AUDIO (L)  
 IC82 7PIN : AUDIO (R)

→No

Check AUDIO+V(+12V) and AUDIO-V(-12V) line and service it if defective.

↓ Yes

Check the DAC(IC71) digital audio data signal of a DSP (IC53). (SGK, BCK, LRCK, DATA)

↓ Yes

Check the DAC(IC71) control signal of a microcomputer (IC55). (MS, MC, MDI)

↓ Yes

Check DAC\_Vcc(+5V) line and service it if defective.

↓ Yes

Replace IC71.

↓ Yes

Is the "H" level MUTE line to Pins(1) of CN31?

↓ Yes

Check POWER MUTE line and F\_MUTE line service it if defective.  
 IC55 20PIN MUTE H : mute / L : play

# WAVEFORMS

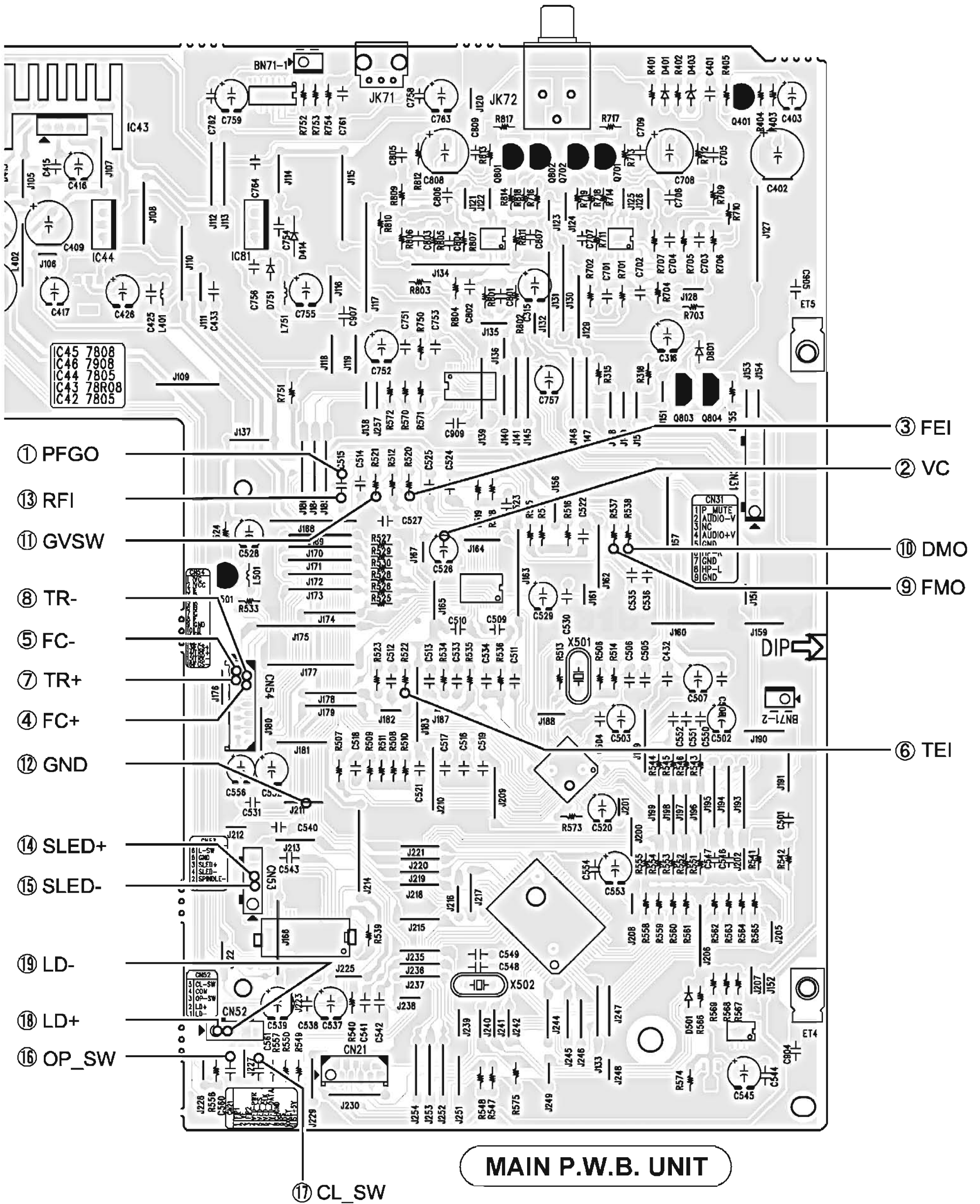

WAVE-FORMS OF EACH POINT

1. PLAY (RF wave-forms)

①RFGO

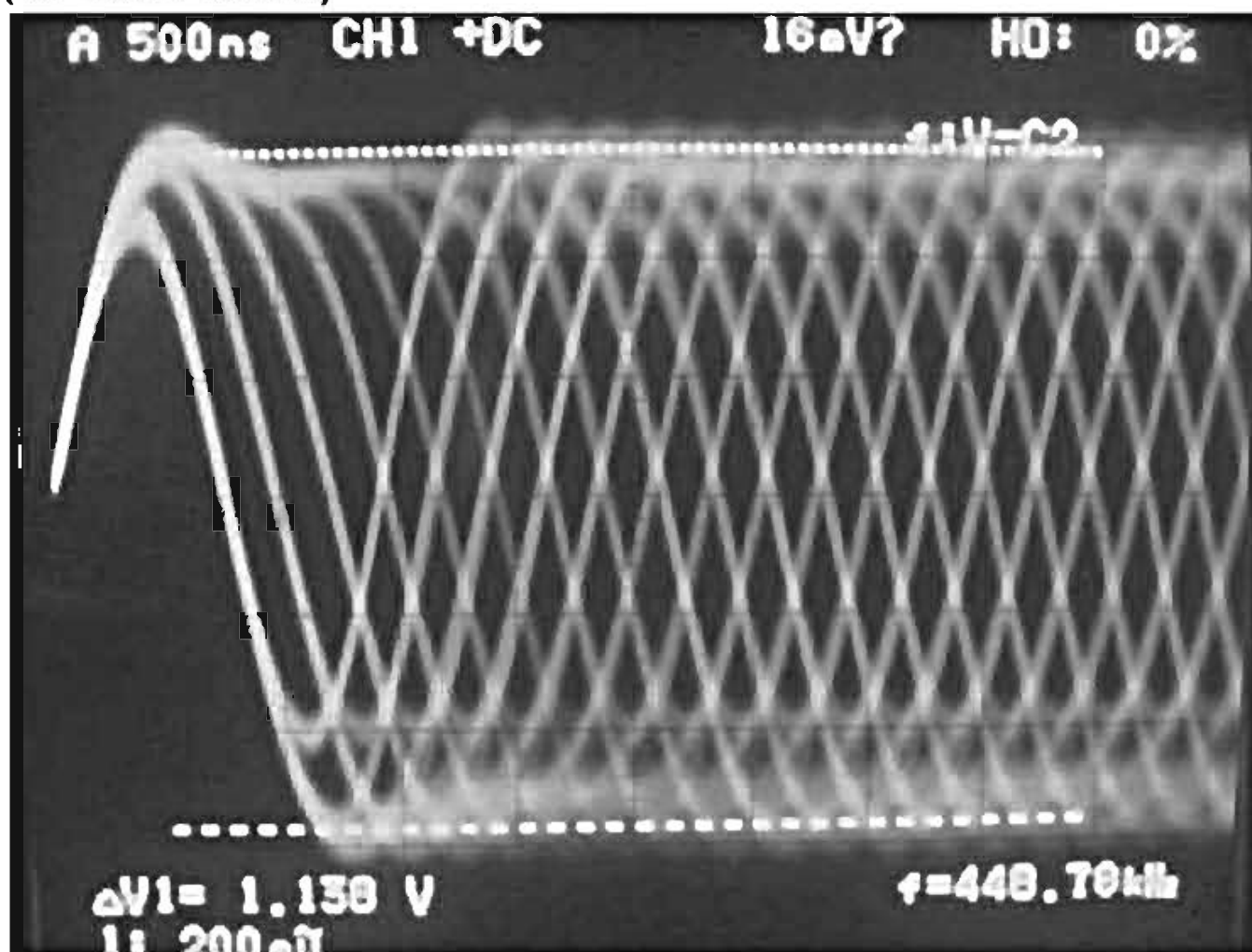

TCD784 During PLAY

GND ; ②VC



## 2. READING

### 2.1 Reading→Play (TCD-784)

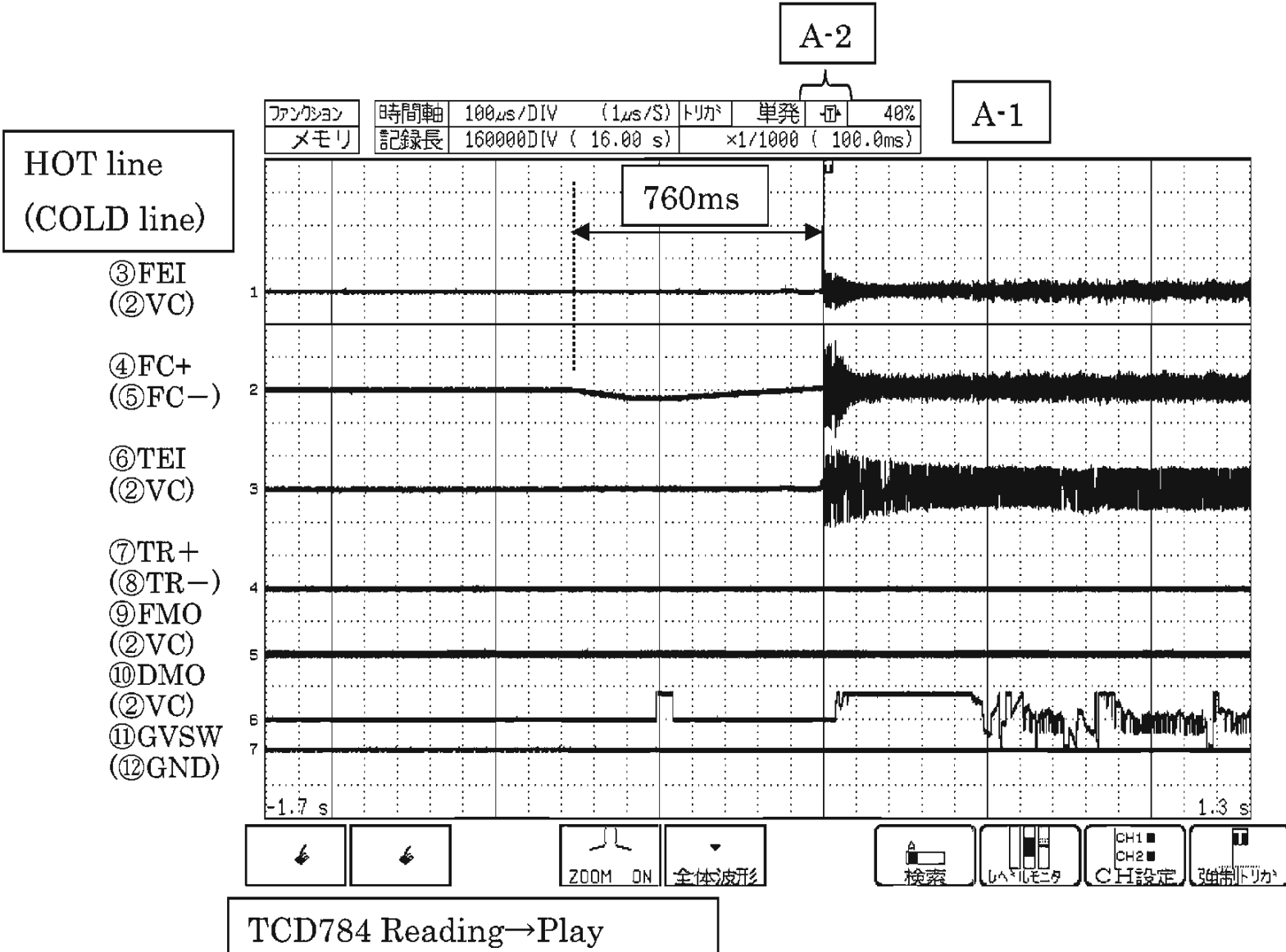
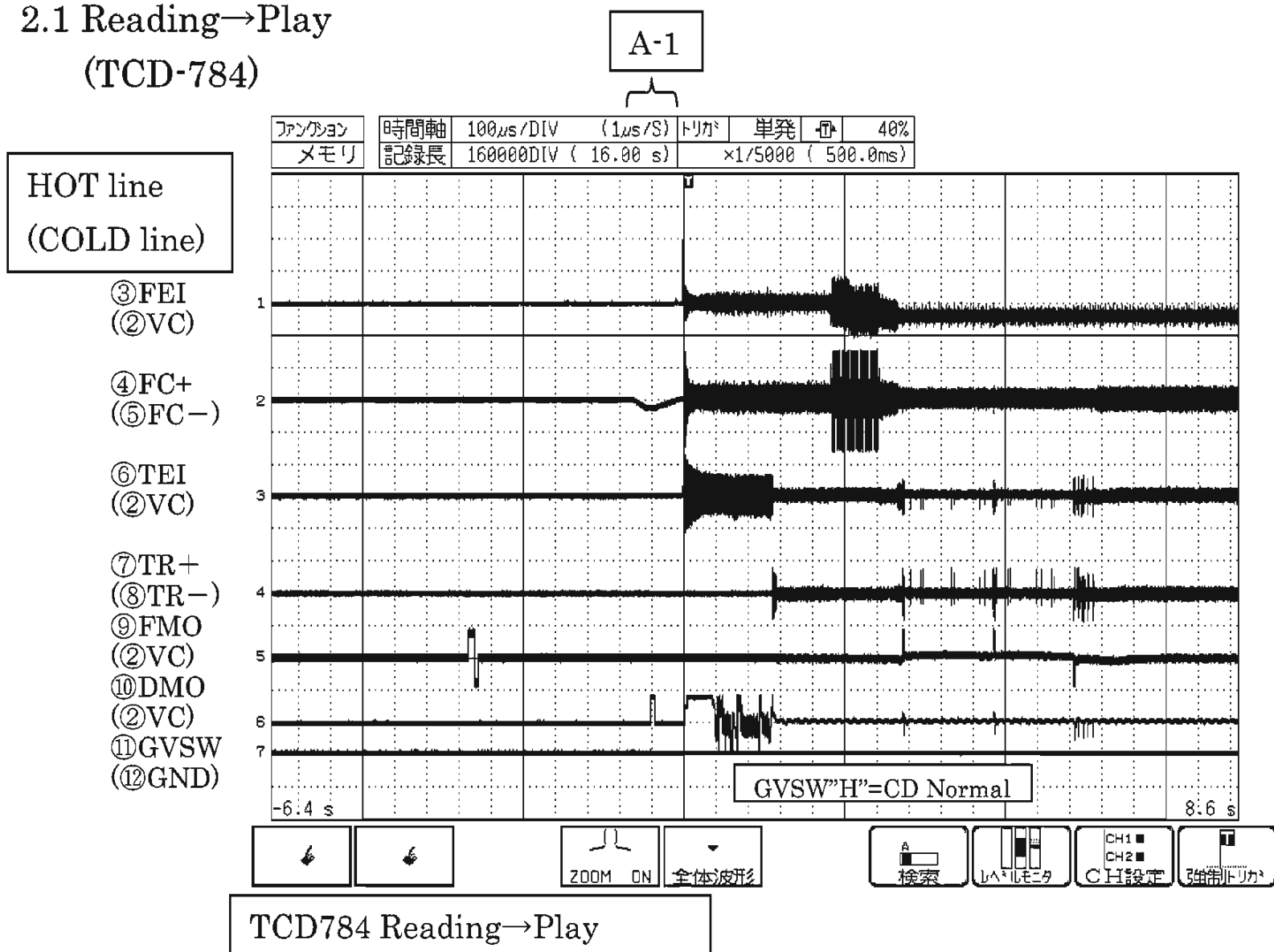

A-2

HOT line  
(COLD line)

- ③FEI  
(②VC)
- ④FC+  
(⑤FC-)
- ⑥TEI  
(②VC)
- ⑦TR+  
(⑧TR-)
- ⑨FMO  
(②VC)
- ⑩DMO  
(②VC)
- ⑪GVSW  
(⑫GND)

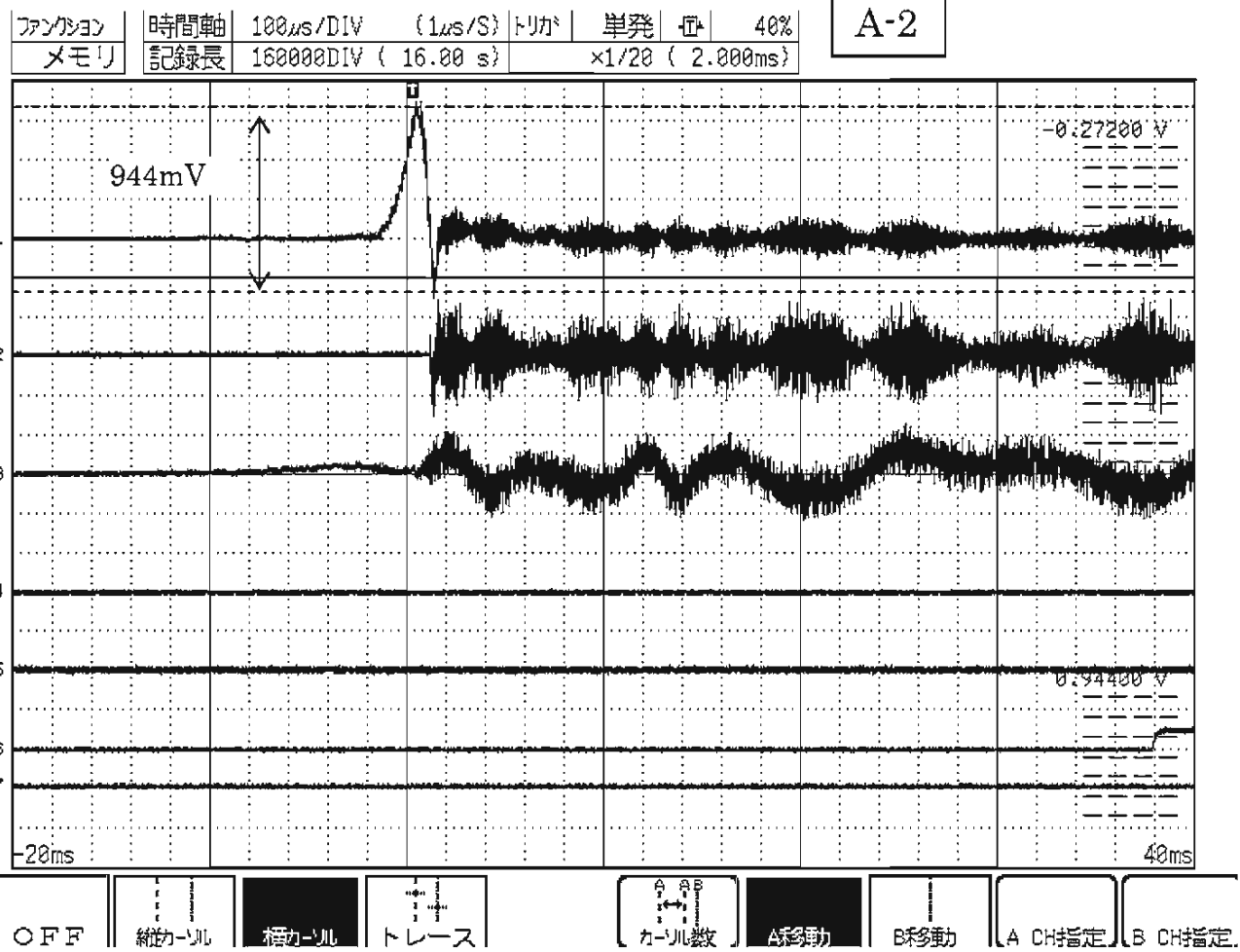

TCD784 DISC detection

DISC distinction standard  
(FEI LEVEL)  
 NO DISC X < 140mV  
 CD-RW 140mV ≤ Y < 580mV  
 ○CD Z ≥ 580mV

MENU	MEMORY											
	ANALOG	LOGIC	XY	OPTION	CH1	CH2	CH3	CH4	CH5	CH6	CH7	CH8
CHANNEL	ONE CH				ANALOG	ANALOG	ANALOG	ANALOG	ANALOG	ANALOG	ANALOG	ANALOG
SCALING					Wave	■	■	■	■	■	■	OFF
TRIGGER					Mode	VOLTAGE	VOLTAGE	VOLTAGE	VOLTAGE	VOLTAGE	VOLTAGE	VOLTAGE
STATUS					Range	200mV	1V	1V	1V	500mV	2V	2V
SYSTEM					Coupling	DC	DC	DC	DC	DC	DC	DC
SET UP					LPF	OFF	OFF	OFF	OFF	OFF	OFF	OFF
FILE SAVE					Zoom	x1	x1	x1	x1	x1	x1	x1
PRINTER					Position	80%	65%	50%	35%	25%	15%	5%
INTERFACE					Variable	OFF	OFF	OFF	OFF	OFF	OFF	OFF
INITIALIZE					/DIV	200mV	1V	1V	1V	500mV	2V	2V
SELF CHECK					Disp	0.8	7	10	13	7.5	34	38
					Limits	-3.2	-13	-10	-7	-2.5	-6	-2
					Meas	4	20	20	20	10	40	40
					Limits	-4	-20	-20	-20	-10	-40	-40
					Unit	V	V	V	V	V	V	V

Operation Guide This screen allows changing each channel setting from a list. Use the F1 and F2 keys to switch setting screens, and use the F3 key to change between the analog, logic and XY setting screens.

MENU (down arrow) MENU (up arrow) PAGE (right arrow) MEMORY (memory icon) RECORDER (recorder icon) 0 Adjust

TCD784 Setting

2.2 Reading→Play  
(TCD-W082L)

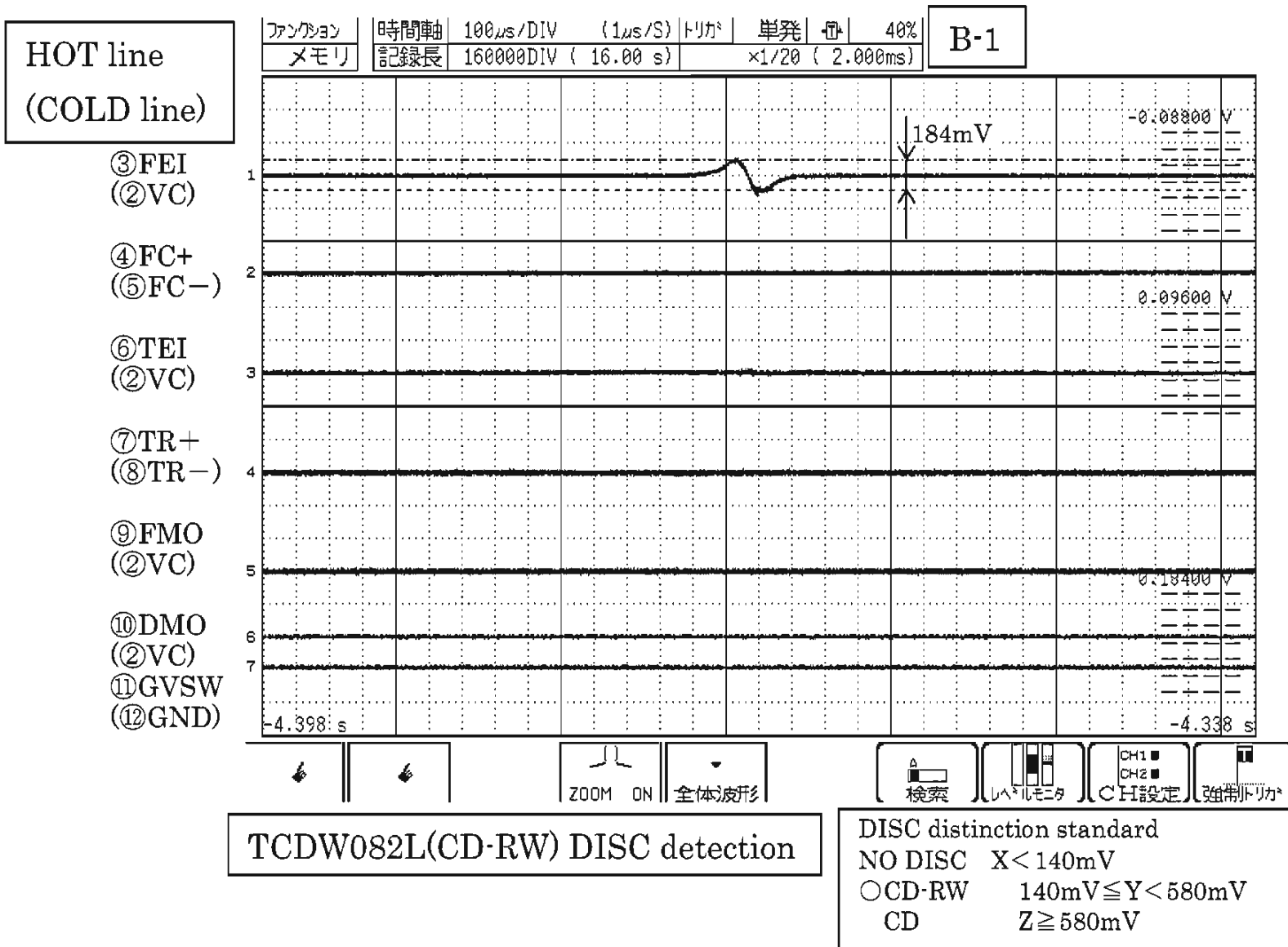
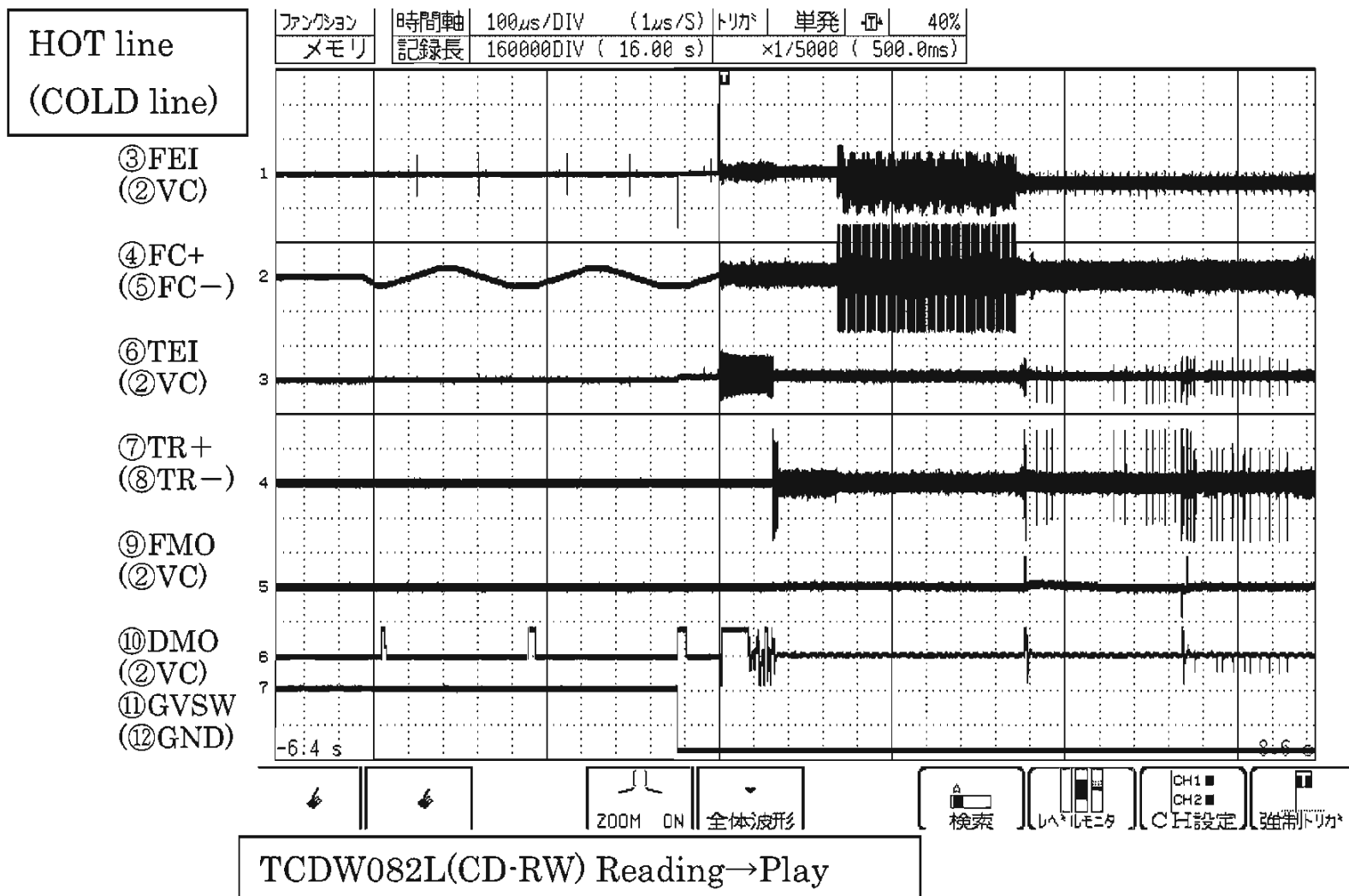
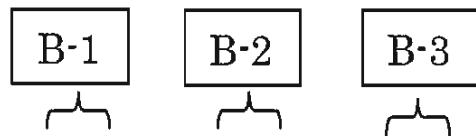

HOT line  
(COLD line)

ファンクション | 時間軸 | 100µs/DIV (1µs/S) | トリガ | 単発 | 40%  
メモリ | 記録長 | 160000DIV (16.00 s) | ×1/20 (2.000ms)

B-2

- ③FEI  
(②VC)
- ④FC+  
(⑤FC-)
- ⑥TEI  
(②VC)
- ⑦TR+  
(⑧TR-)
- ⑨FMO  
(②VC)
- ⑩DMO  
(②VC)
- ⑪GVSW  
(②GND)

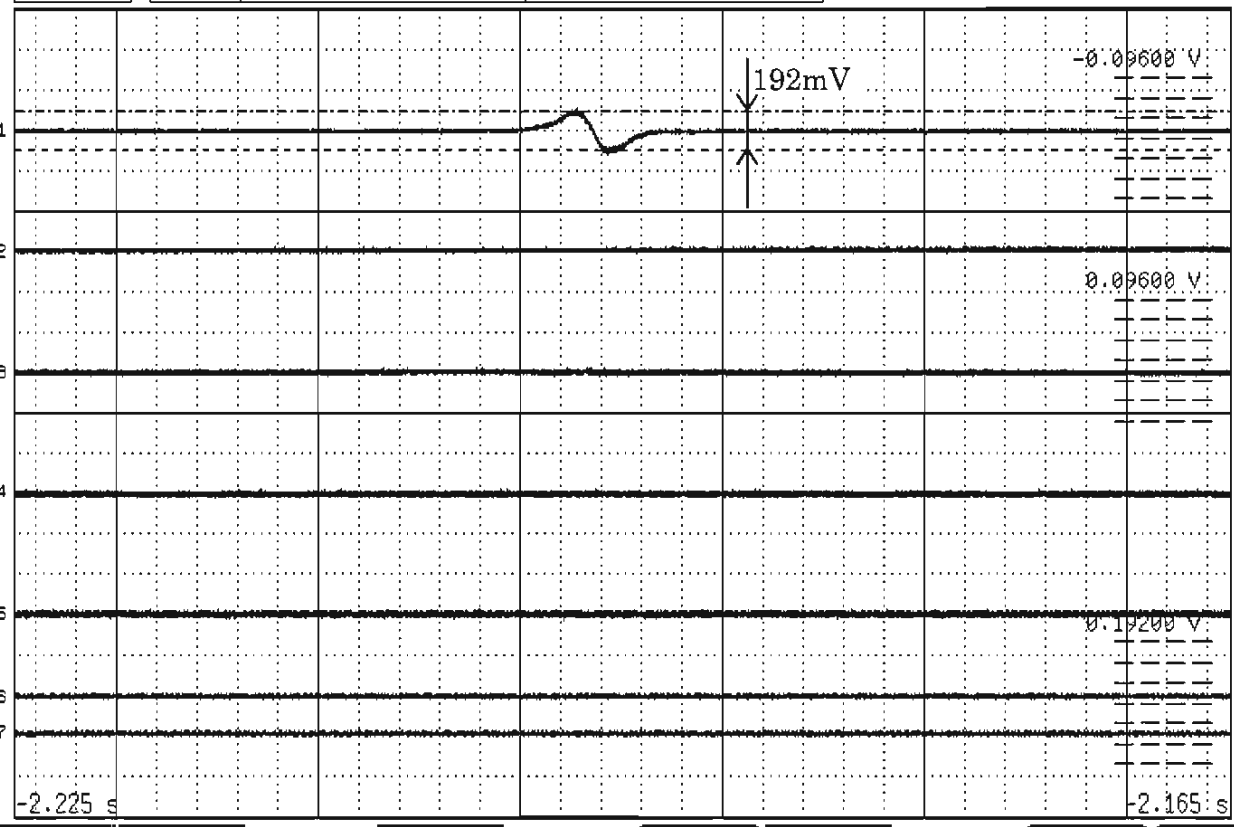

OFF 縦カーリル 横カーリル トレース カール数 A種多動 B種多動 A CH指定 B CH指定

TCDW082L(CD-RW) Reading→Play

MENU

MEMORY

- CHANNEL
  - ONE CH
  - SCALING
  - COMMENT
- TRIGGER
  - TRIGGER
- STATUS
  - STATUS
  - MEMORY DIV
  - MEASUREMENT
- SYSTEM
  - SET UP
  - FILE SAVE
  - PRINTER
  - INTERFACE
  - INITIALIZE
  - SELF CHECK

	ANALOG	LOGIC	XY	OPTION	CH1	CH2	CH3	CH4	CH5	CH6	CH7	CH8
Amp	ANALOG	ANALOG	ANALOG	ANALOG	ANALOG	ANALOG	ANALOG	ANALOG	ANALOG	ANALOG	ANALOG	ANALOG
Wave	■	■	■	■	■	■	■	■	■	■	■	OFF
Graph												
Mode	VOLTAGE	VOLTAGE	VOLTAGE	VOLTAGE	VOLTAGE	VOLTAGE	VOLTAGE	VOLTAGE	VOLTAGE	VOLTAGE	VOLTAGE	VOLTAGE
Range	200mV	1V	1V	500mV	500mV	2V	2V	200mV				
Coupling	DC	DC	DC	DC	DC	DC	DC	DC	DC	DC	DC	DC
LPF	OFF	OFF	OFF	OFF	OFF	OFF	OFF	OFF	OFF	OFF	OFF	OFF
Zoom	×1	×1	×1	×1	×1	×1	×1	×1	×1	×1	×1	×1
Position	85%	70%	55%	40%	25%	15%	5%	45%				
Variable	OFF	OFF	OFF	OFF	OFF	OFF	OFF	OFF	OFF	OFF	OFF	OFF
/DIV	200mV	1V	1V	500mV	500mV	2V	2V	200mV				
Disp	0.6	6	9	6	7.5	34	38	2.2				
Limits	-3.4	-14	-11	-4	-2.5	-6	-2	-1.8				
Meas	4	20	20	10	10	40	40	4				
Limits	-4	-20	-20	-10	-10	-40	-40	-4				
Unit	V	V	V	V	V	V	V	V				

Operation Guide This screen allows changing each channel setting from a list. Use the F1 and F2 keys to switch setting screens, and use the F3 key to change between the analog, logic and XY setting screens.

MENU MENU PAGE MEMORY RECORDER

Adjust

TCDW082L(CD-RW) Setting

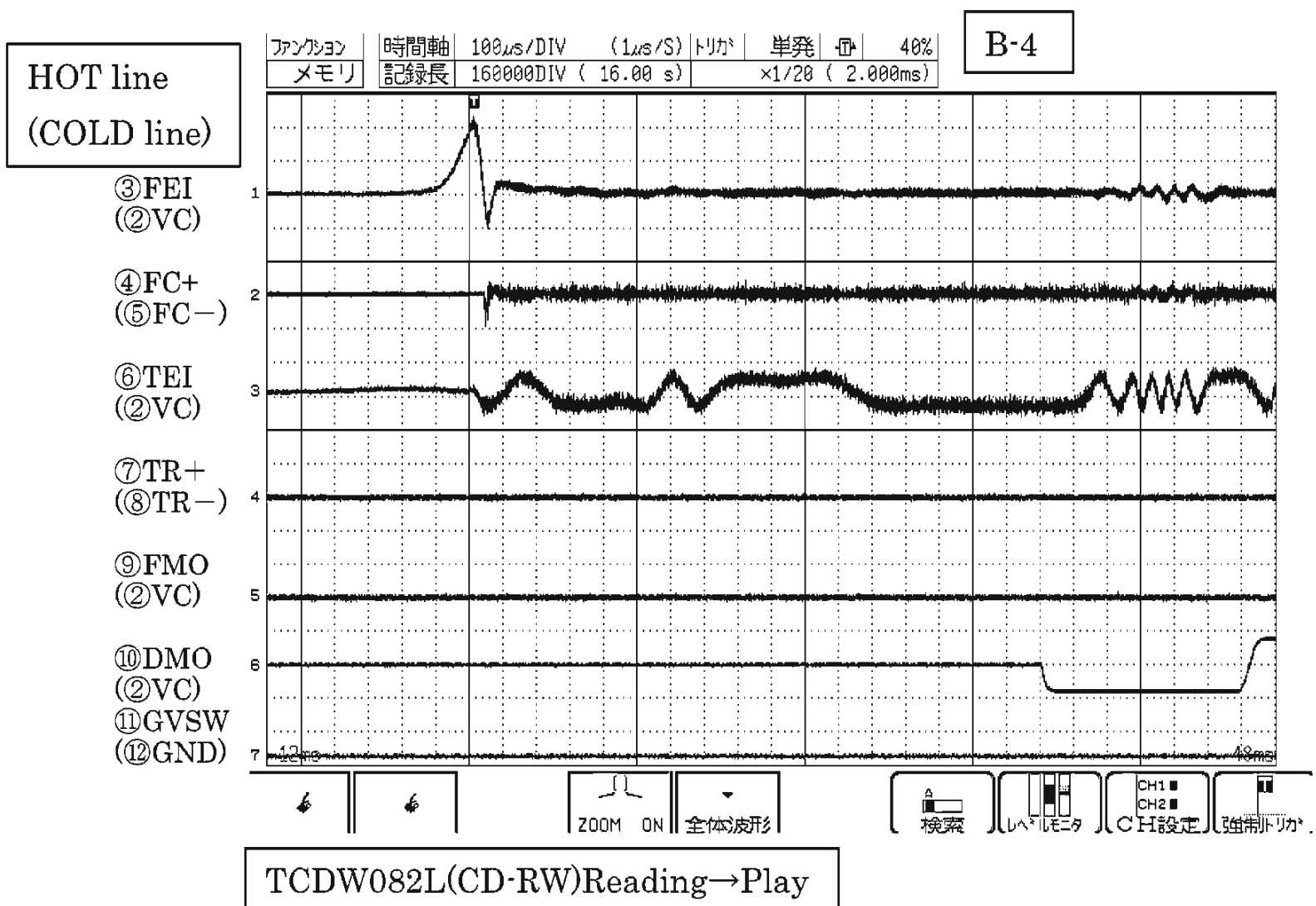
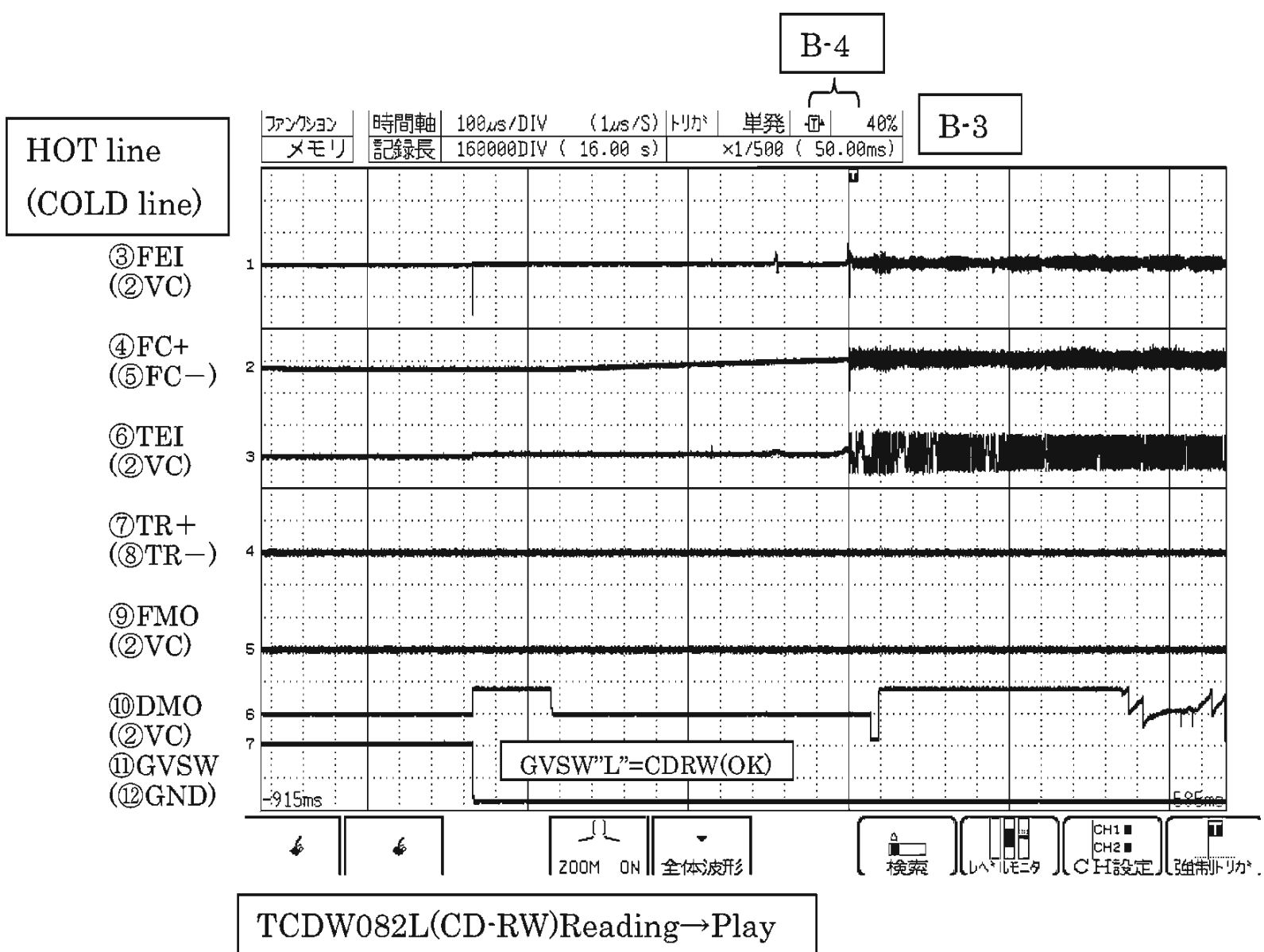

HOT line  
(COLD line)

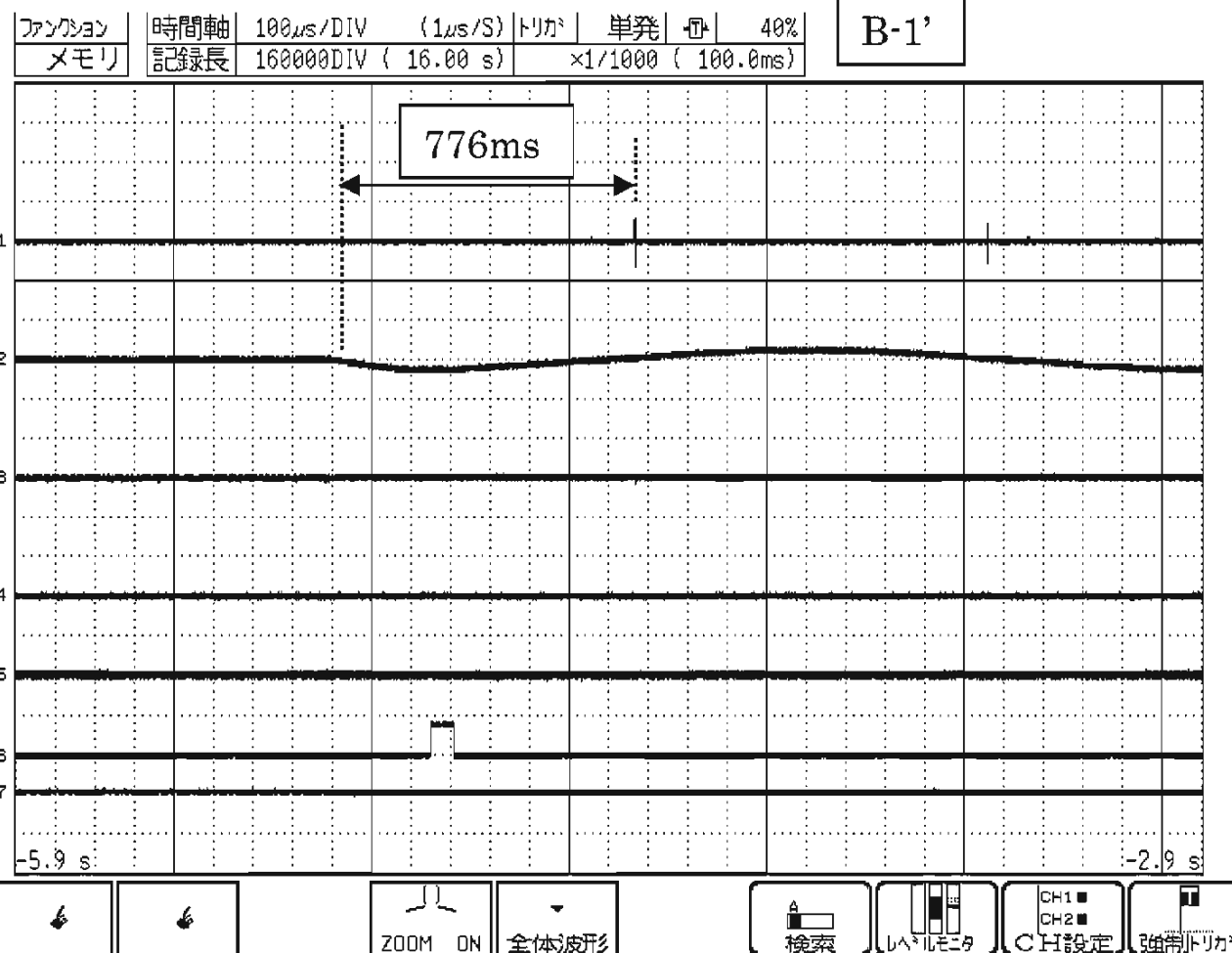

TCDW082L(CD-RW) Reading→Play

MENU	MEMORY											
	ANALOG	LOGIC	XY	OPTION	CH1	CH2	CH3	CH4	CH5	CH6	CH7	CH8
CHANNEL	ONE CH											
SCALING												
COMMENT												
TRIGGER												
TRIGGER												
STATUS												
STATUS												
MEMORY DIV												
MEASUREMENT												
SYSTEM												
SET UP												
FILE SAVE												
PRINTER												
INTERFACE												
INITIALIZE												
SELF CHECK												
		CH1	CH2	CH3	CH4	CH5	CH6	CH7	CH8			
Amp	ANALOG	ANALOG	ANALOG	ANALOG	ANALOG	ANALOG	ANALOG	ANALOG	ANALOG			
Wave	■	■	■	■	■	■	■	■	■			OFF
Graph												
Mode	VOLTAGE	VOLTAGE	VOLTAGE	VOLTAGE	VOLTAGE	VOLTAGE	VOLTAGE	VOLTAGE	VOLTAGE			
Range	200mV	1V	1V	1V	500mV	2V	2V	2V	200mV			
Coupling	DC	DC	DC	DC	DC	DC	DC	DC	DC			
LPF	OFF	OFF	OFF	OFF	OFF	OFF	OFF	OFF	OFF			
Zoom	x1	x1	x1	x1	x1	x1	x1	x1	x1			
Position	80%	65%	50%	35%	25%	15%	5%	45%				
Variable	OFF	OFF	OFF	OFF	OFF	OFF	OFF	OFF	OFF			
/DIV	200mV	1V	1V	1V	500mV	2V	2V	2V	200mV			
Disp	0.8	7	10	13	7.5	34	38	2.2				
Limits	-3.2	-13	-10	-7	-2.5	-6	-2	-1.8				
Meas	4	20	20	20	10	40	40	4				
Limits	-4	-20	-20	-20	-10	-40	-40	-4				
Unit	V	V	V	V	V	V	V	V				

Operation Guide This screen allows changing each channel setting from a list. Use the F1 and F2 keys to switch setting screens, and use the F3 key to change between the analog, logic and XY setting screens.

MENU MENU PAGE MEMORY RECORDER 0 Adjust

TCDW082L(CD-RW) Setting

### 3. During Pause

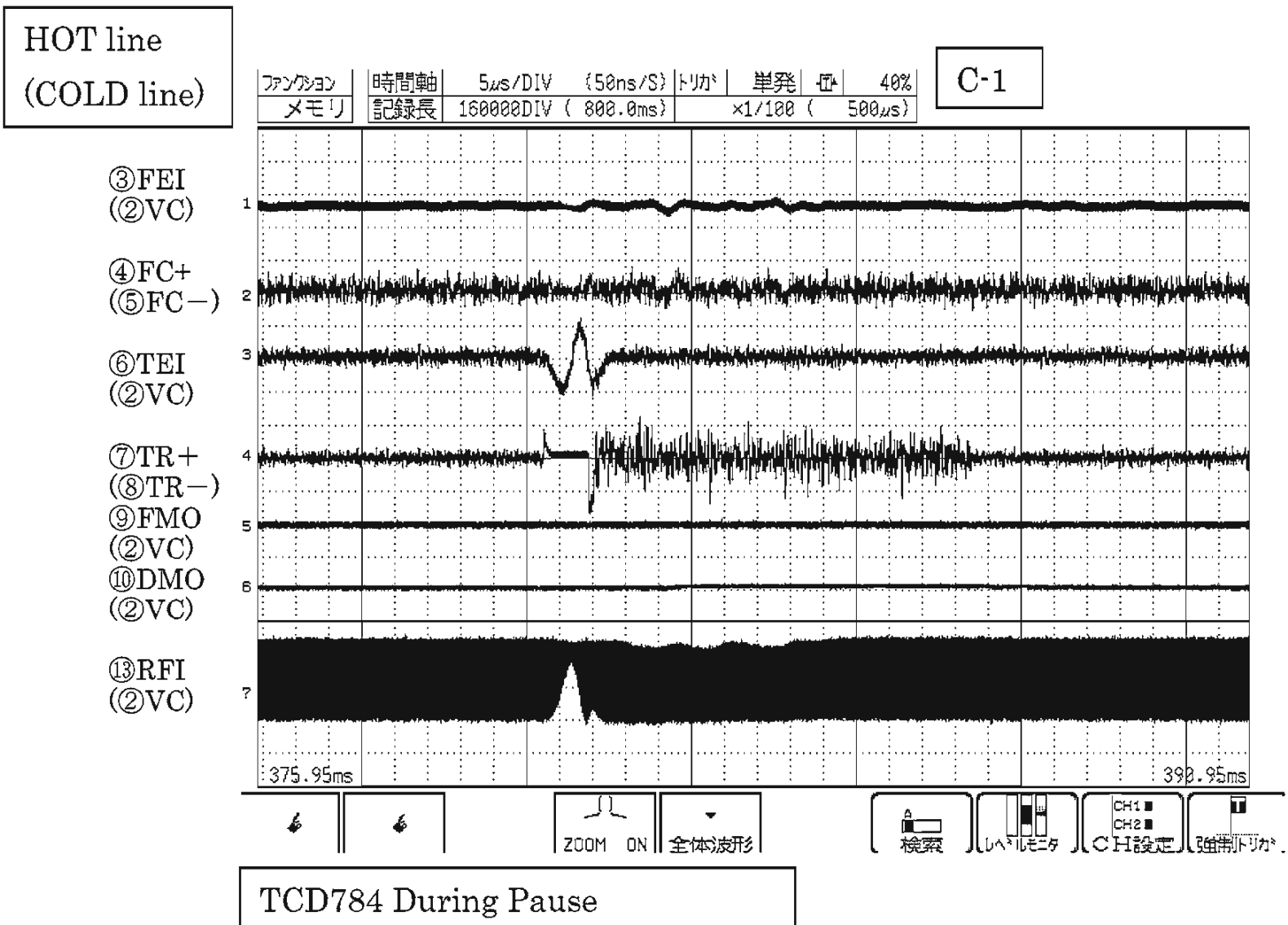
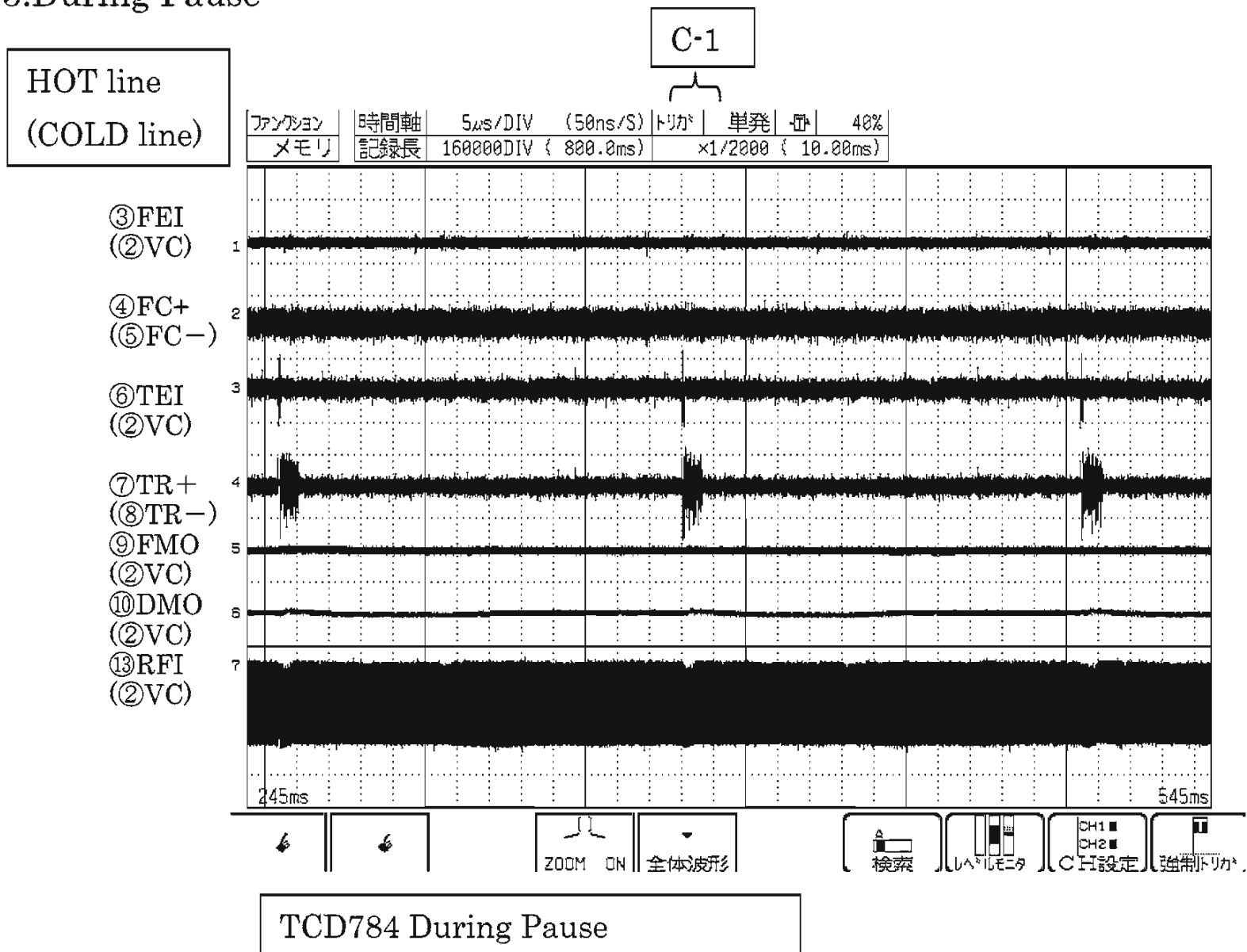

4. Track search

HOT line  
(COLD line)

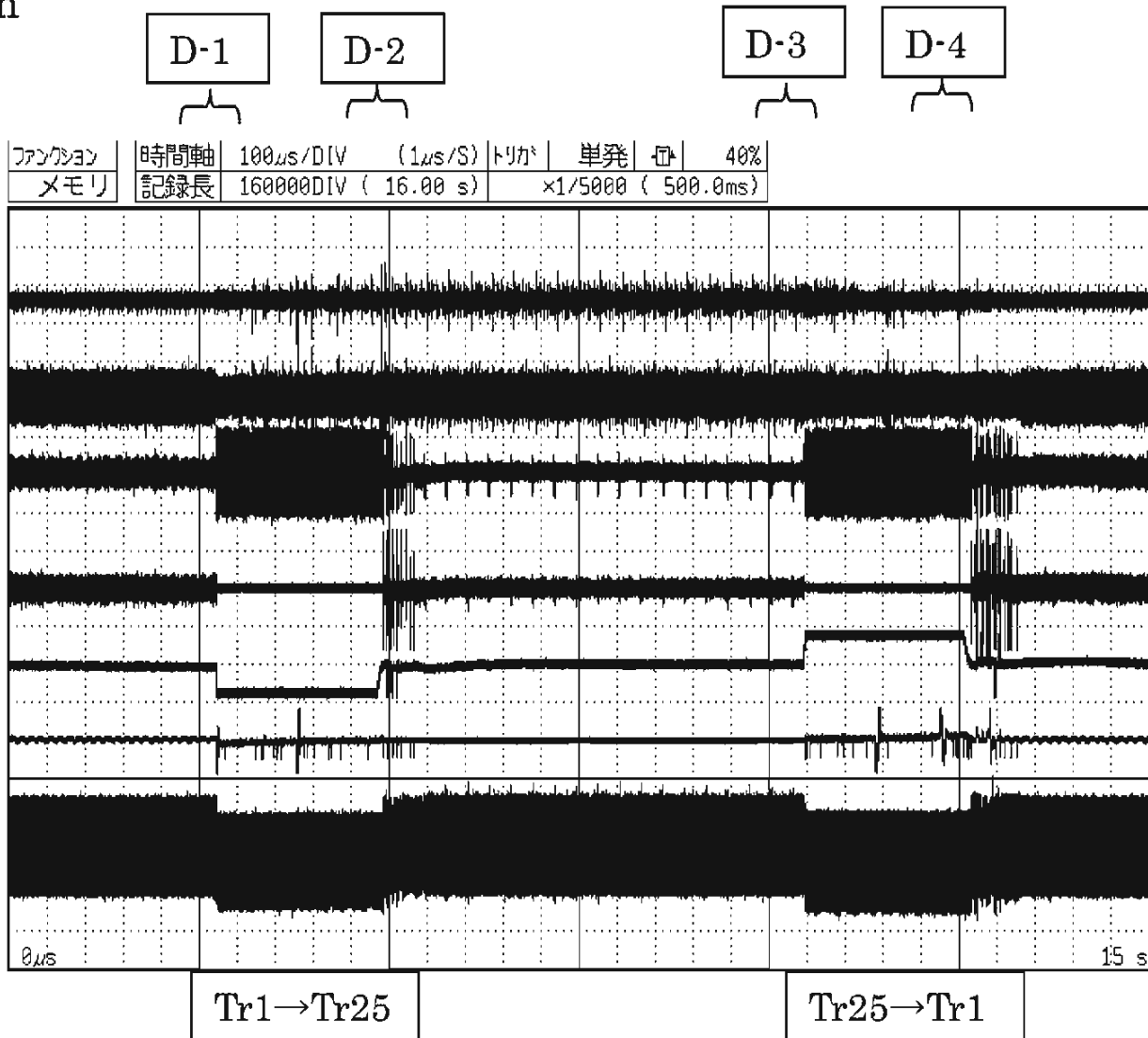

TCD784 Tr1→Tr25→Tr1 Search

HOT line  
(COLD line)

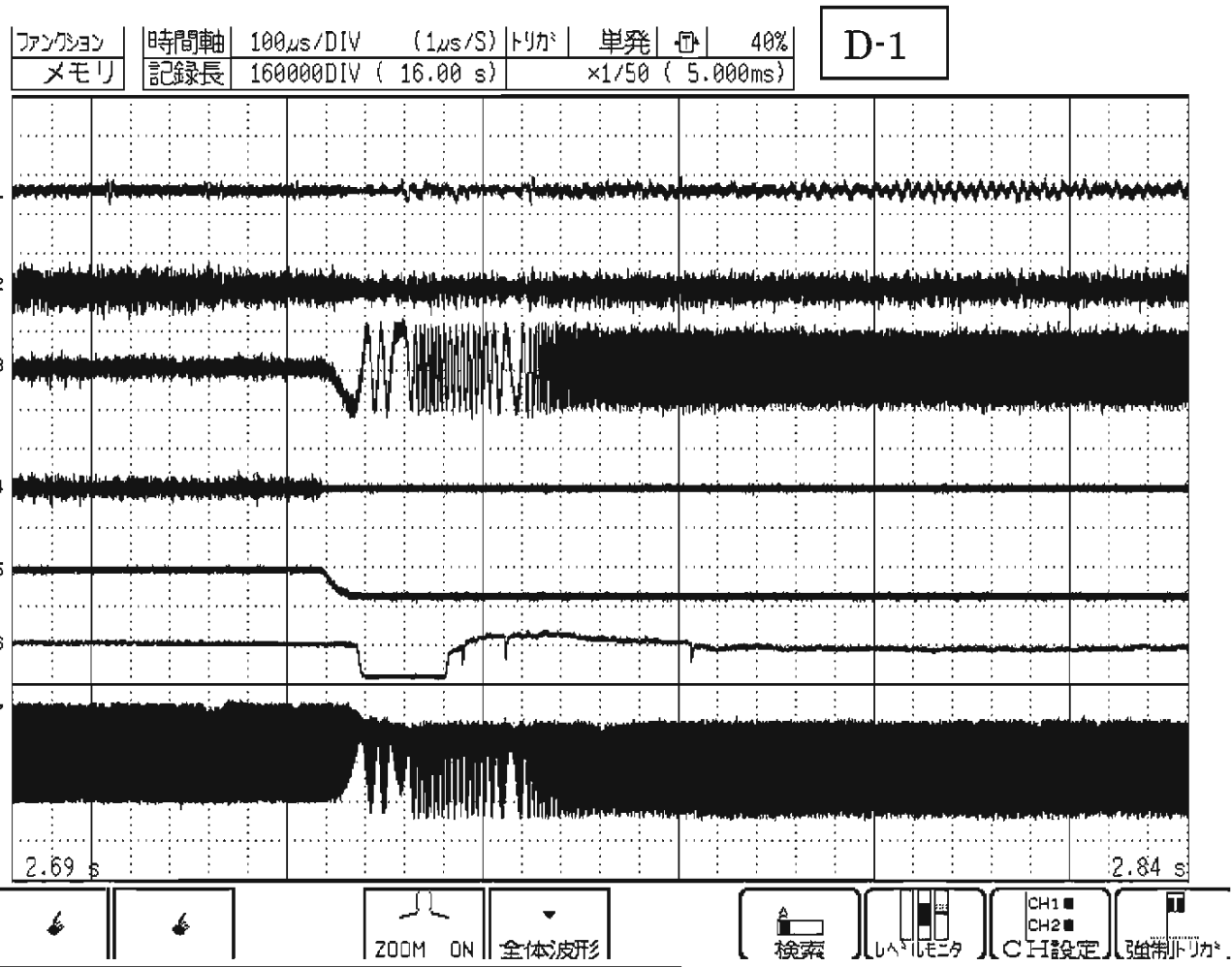

TCD784 Tr1→Tr25 Search start



HOT line  
(COLD line)

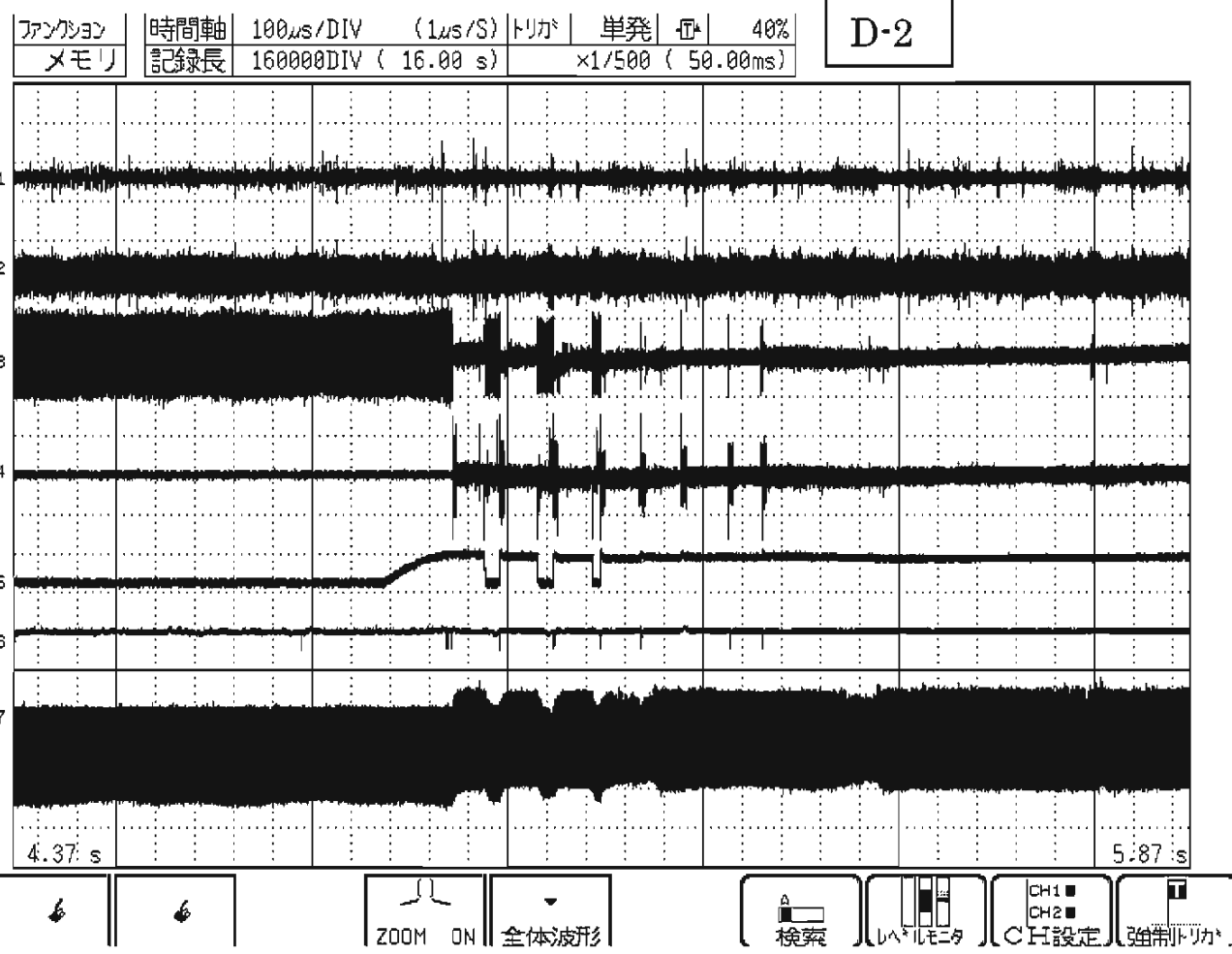

TCD784 Tr1→Tr25 Search end

HOT line  
(COLD line)

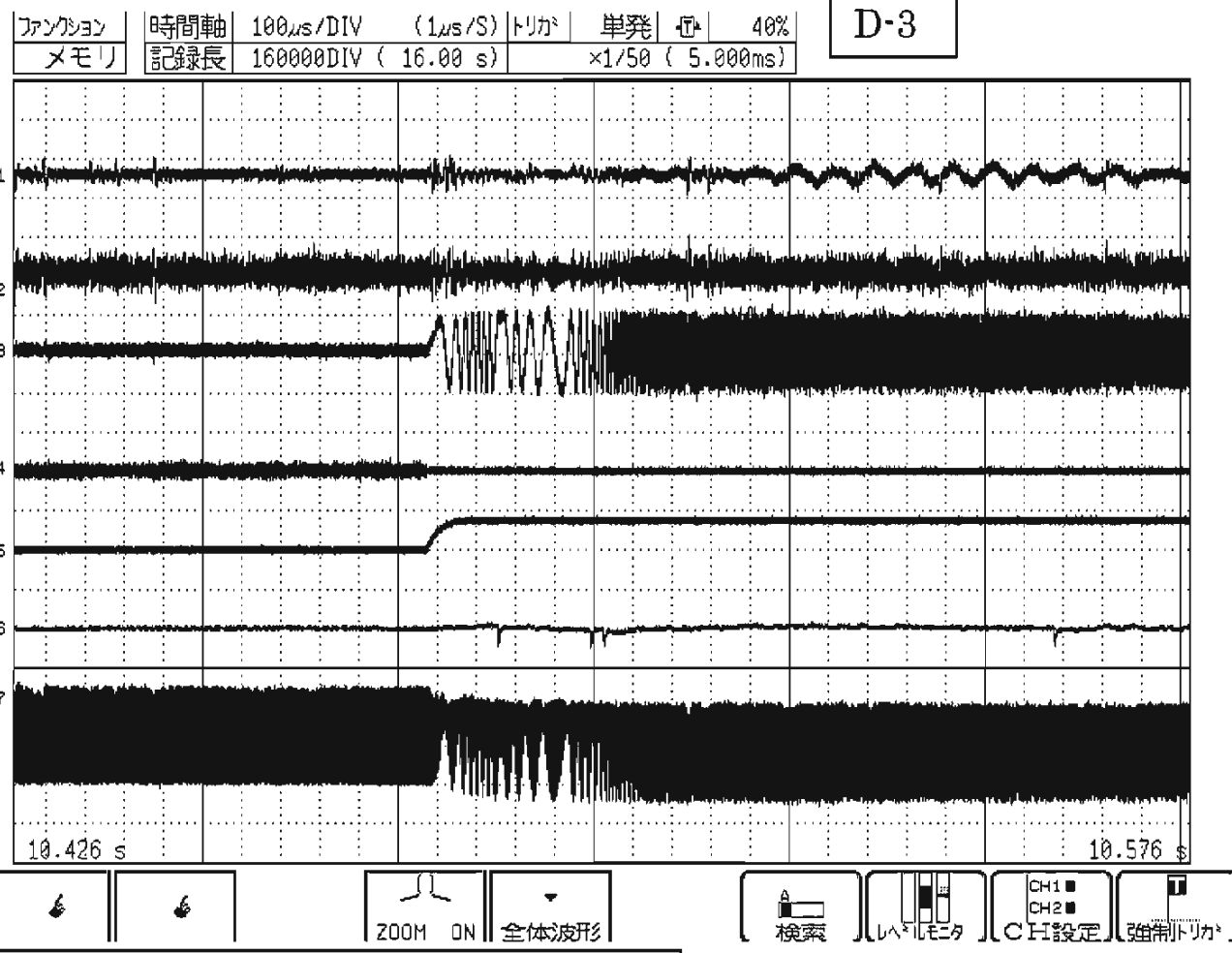

TCD784 Tr25→Tr1 Search start

HOT line  
(COLD line)

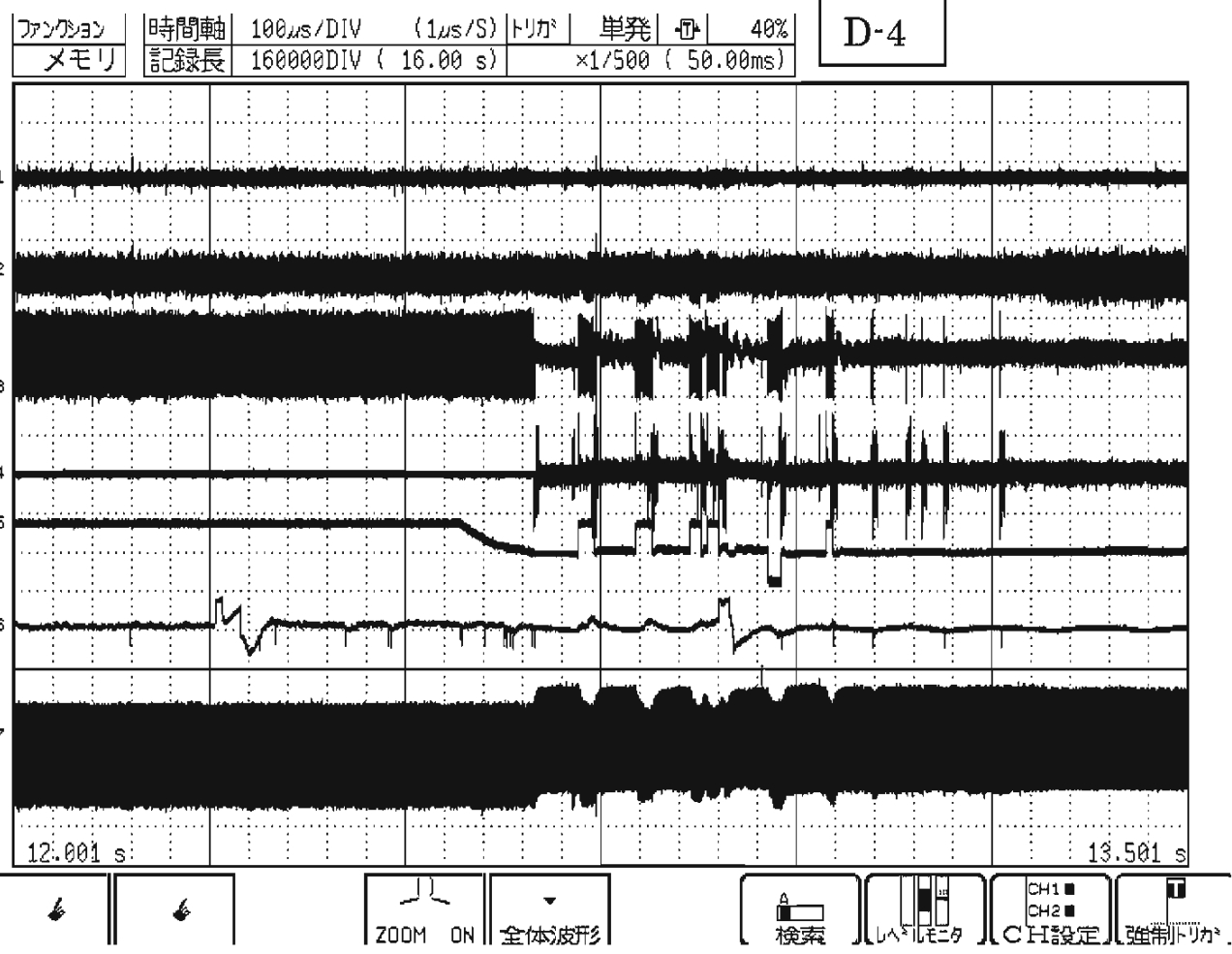

TCD784 Tr25→Tr1 Search end

**MENU**

- CHANNEL
- ONE CH
- SCALING
- COMMENT
- TRIGGER
- TRIGGER
- STATUS
- STATUS
- MEMORY DIV
- MEASUREMENT
- SYSTEM
- SET UP
- FILE SAVE
- PRINTER
- INTERFACE
- INITIALIZE
- SELF CHECK

MEMORY

ANALOG LOGIC XY OPTION

	CH1	CH2	CH3	CH4	CH5	CH6	CH7	CH8
Amp	ANALOG	ANALOG	ANALOG	ANALOG	ANALOG	ANALOG	ANALOG	ANALOG
Wave	■	■	■	■	■	■	■	OFF
Graph								
Mode	VOLTAGE	VOLTAGE	VOLTAGE	VOLTAGE	VOLTAGE	VOLTAGE	VOLTAGE	VOLTAGE
Range	200mV	500mV	500mV	500mV	500mV	2V	500mV	200mV
Coupling	DC	DC	DC	DC	DC	DC	DC	DC
LPF	OFF	OFF	OFF	OFF	OFF	OFF	OFF	OFF
Zoom	×1	×1	×1	×1	×1	×1	×1	×1
Position	90%	75%	65%	50%	40%	30%	20%	45%
Variable	OFF	OFF	OFF	OFF	OFF	OFF	OFF	OFF
/DIV	200mV	500mV	500mV	500mV	500mV	2V	500mV	200mV
Disp	0.4	2.5	3.5	5	6	28	8	2.2
Limits	-3.6	-7.5	-6.5	-5	-4	-12	-2	-1.8
Meas	4	10	10	10	10	40	10	4
Limits	-4	-10	-10	-10	-10	-40	-10	-4
Unit	V	V	V	V	V	V	V	V

Operation Guide This screen allows changing each channel setting from a list. Use the F1 and F2 keys to switch setting screens, and use the F3 key to change between the analog, logic and XY setting screens.

MENU
MENU
PAGE
MEMORY
RECORDER

Adjust

TCD784 Tr1→Tr25→Tr1 Search setting

5. During Play

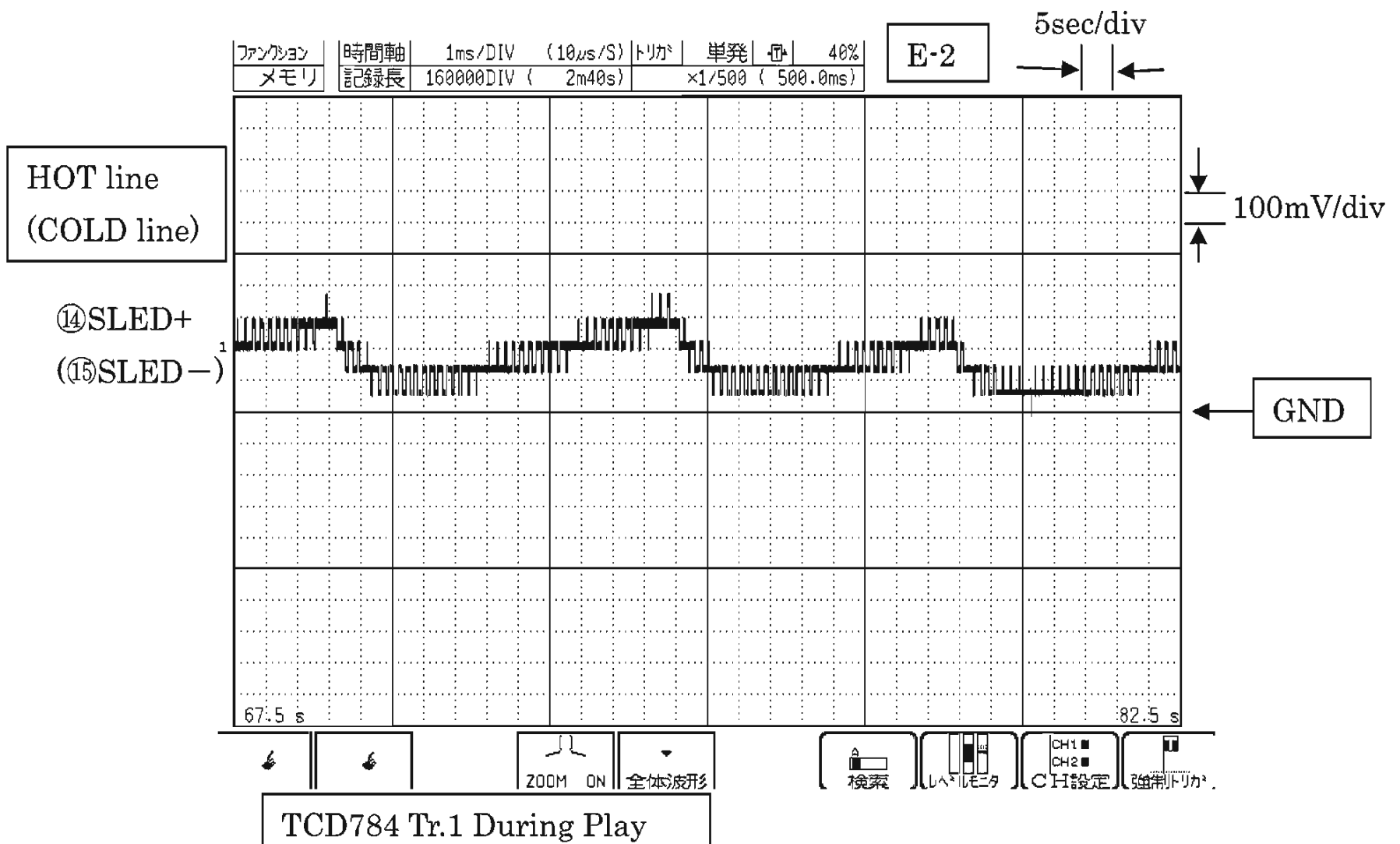
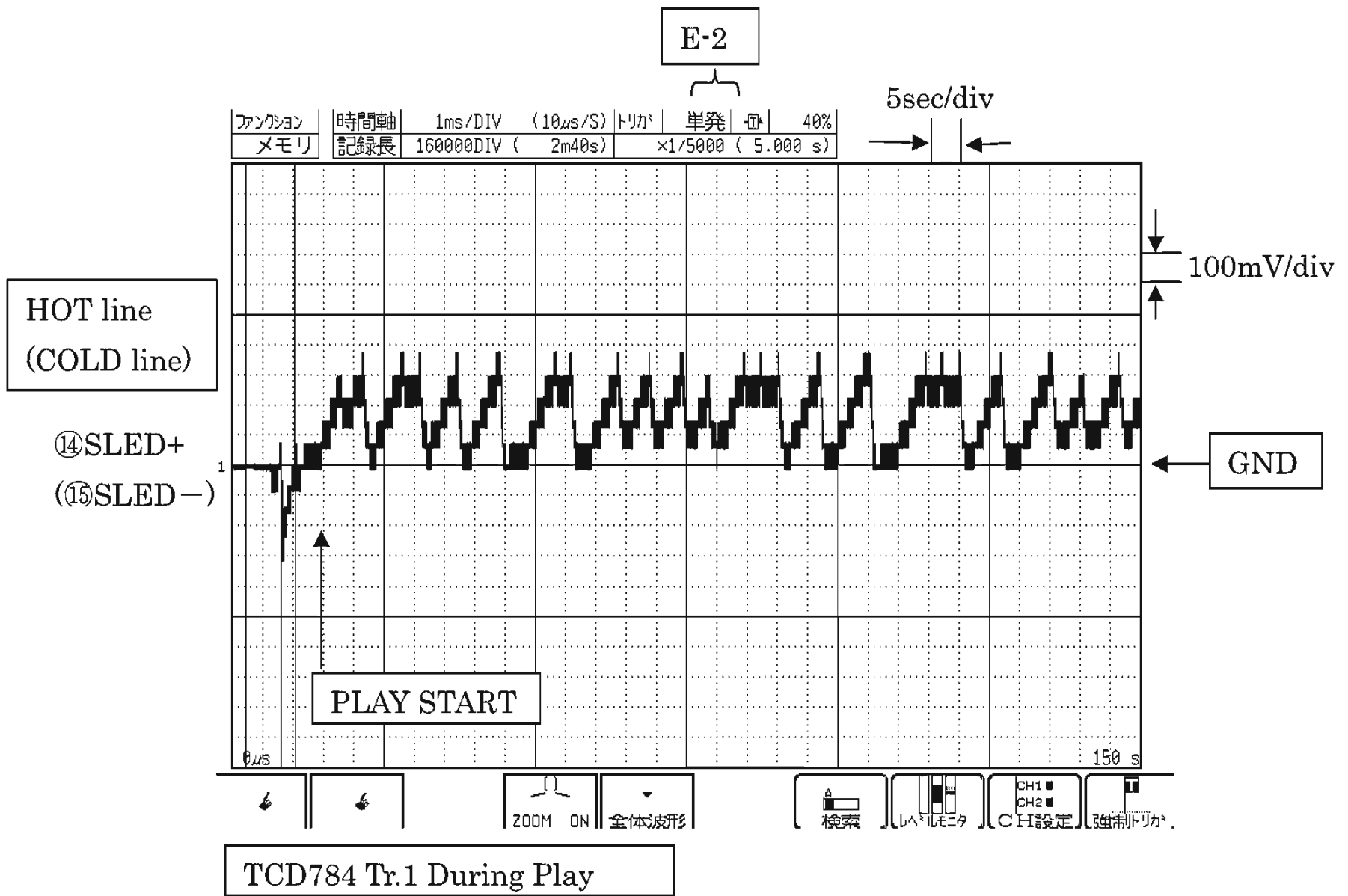

6. Loader OPEN-CLOSE

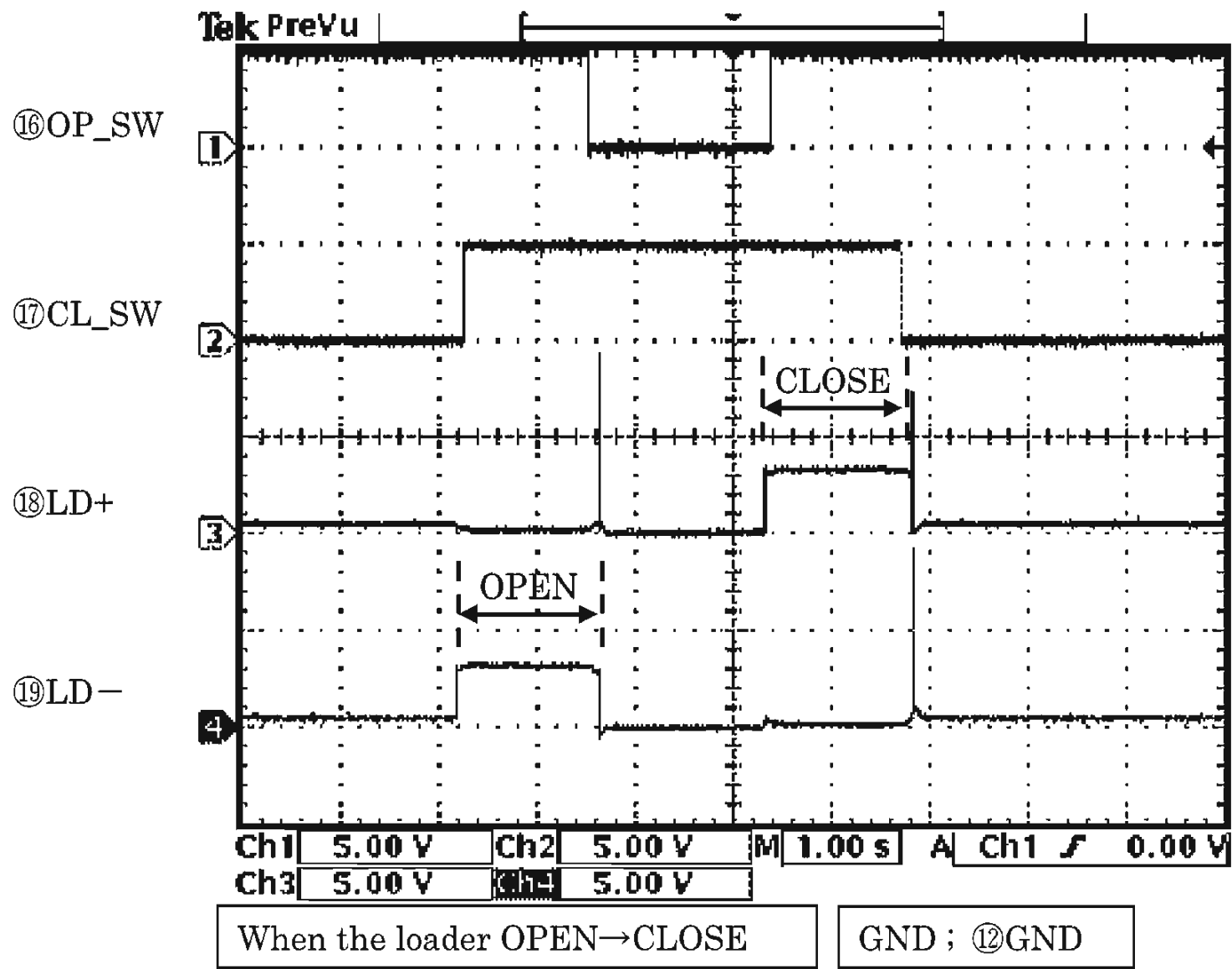

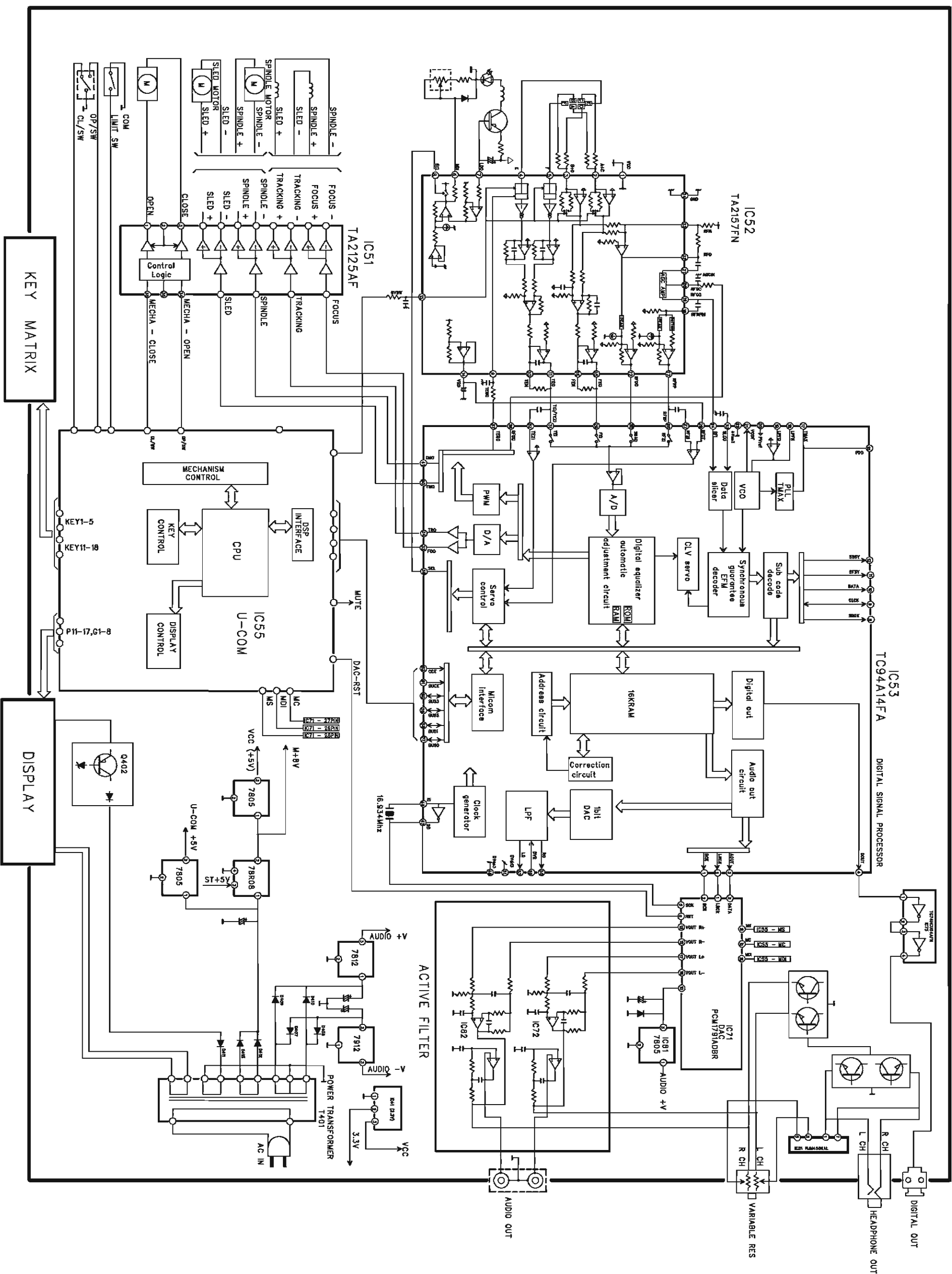

# SEMICONDUCTORS

Only major semiconductors are shown, general semiconductors etc. are omitted to list.  
 主な半導体を記載しています。汎用の半導体は記載を省略しています。

## 1. IC's

### TMP87PS71AFG (IC 55)

#### Pin Assignments

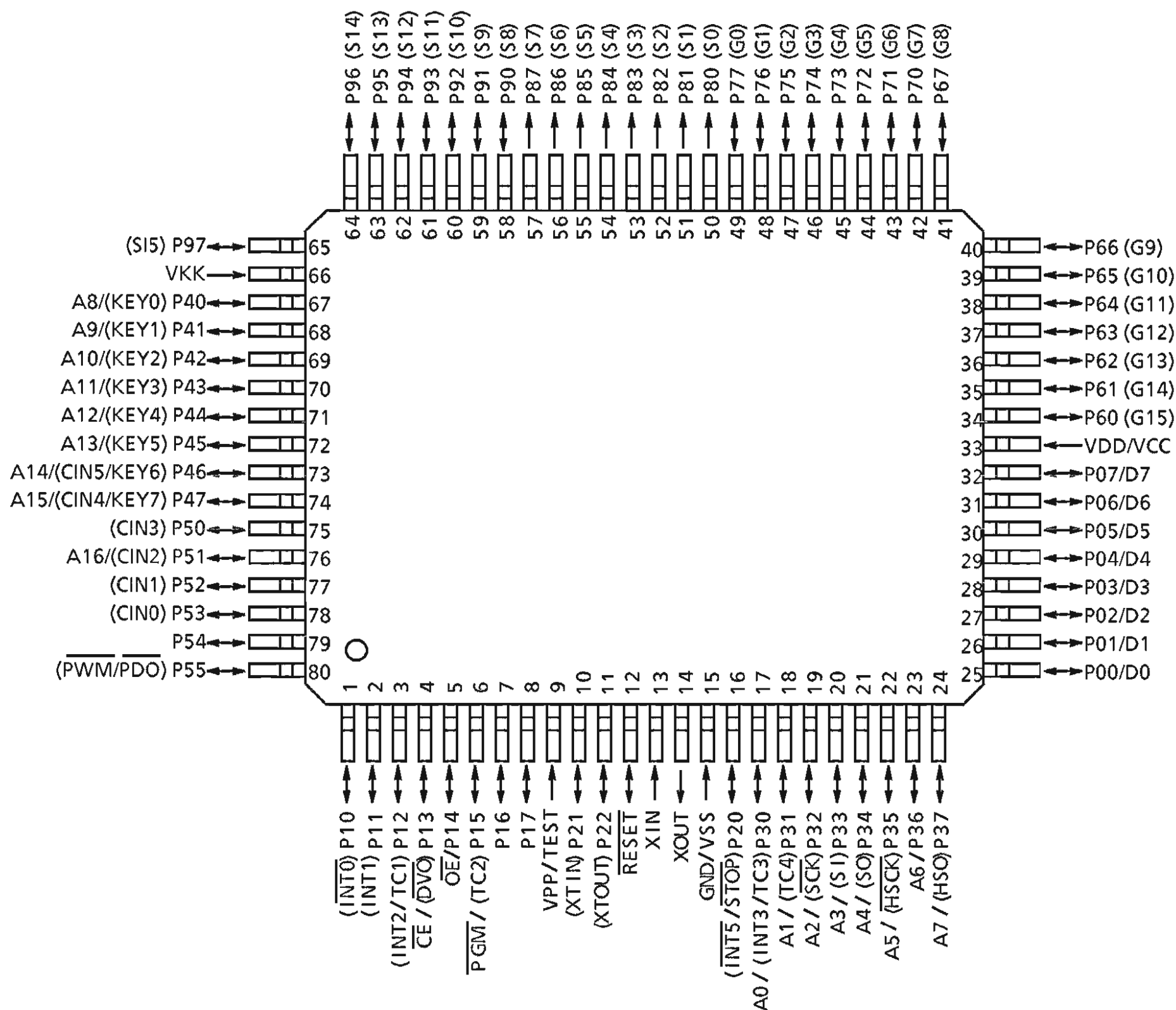

## Pin Functions

The TMP87PS71A has two modes: MCU and PROM.

(1) MCU mode

In this mode, the TMP87PS71A is pin compatible with the TMP87CS71B (fix the TEST pin at low level).

(2) PROM mode

Pin Name (PROM mode)	Input/Output	Functions	Pin Name (MCU mode)
A16	Input	PROM address inputs	P51
A15 to A8			P47 to P40
A7 to A0			P37 to P30
D7 to D0	I/O	PROM data input/outputs	P07 to P00
$\overline{CE}$	Input	Chip enable signal input (active low)	P13
$\overline{OE}$		Output enable signal input (active low)	P14
$\overline{PGM}$		Program control input (active low)	P15
VPP	Power supply	+ 12.75 V/5 V (Program supply voltage)	TEST
VCC		+ 6.25 V/5 V	VDD
GND		0 V	VSS
P55 to P52	I/O	Pull-down with resistance for input processing	
P11		PROM mode setting pin. Be fixed at high level.	
P21			
P50		PROM mode setting pin. Be fixed at low level.	
P17, P16			
P12, P10			
P22, P20			
$\overline{RESET}$			
XIN	Input	Connect an 8 MHz oscillator to stabilize the internal state.	
XOUT	Output		
VKK	VFT power supply	GND	
P97 to P90	I/O	Open	
P87 to P80	Output		
P77 to P70	I/O		
P67 to P60			

TC94A14FAG (IC 53)

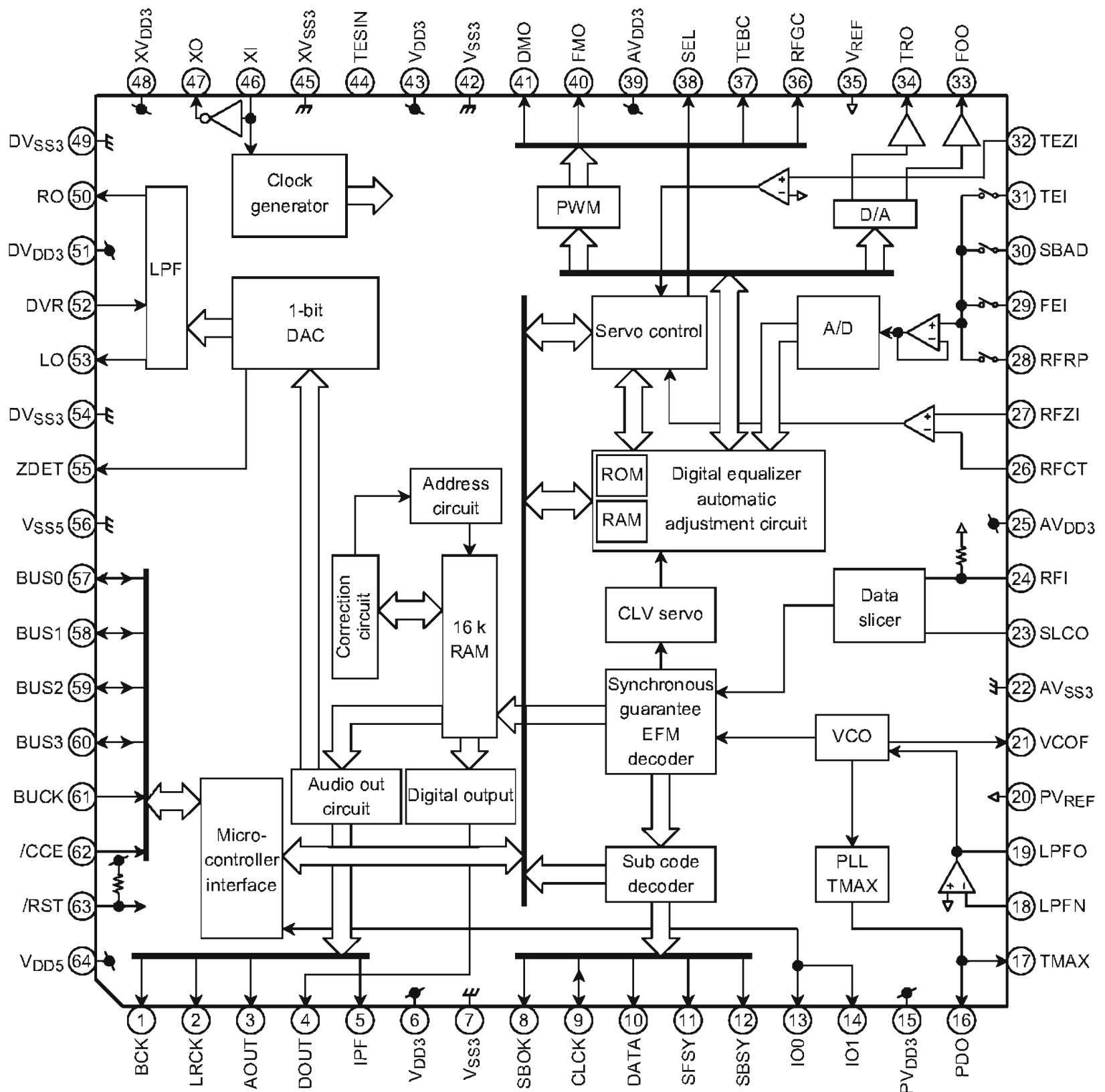

Pin Functions

Pin No.	Symbol	I/O	Function Description	Remarks
1	B CK	O 3-5I/F	Bit clock output pin. 32fs, 48fs, or 64fs selectable by command.	Normal speed: 32fs 1.4112 MHz
2	LRCK	O 3-5I/F	L/R channel clock output pin. "L" for L channel and "H" for R channel. Output polarity can be inverted by command.	Normal speed: 44.1 kHz
3	A OUT	O 3-5I/F	Audio data output pin. MSB-first or LSB-first selectable by command.	
4	DOUT	O 3-5I/F	Digital data output pin. Outputs up to double-speed playback.	Based on CP-1201
5	I PF	O 3-5I/F	Correction flag output pin. When set to "H", AOUT output cannot be corrected by C2 correction processing.	Alias: C2PO
6	V DD3		Digital 3.3 V power supply voltage pin.	
7	V SS3		Digital GND pin.	
8	S BOK	O 3-5I/F	Subcode Q data CRCC result output pin. "H" level when result is OK.	
9	CLCK	I/O 3-5I/F	Subcode P-W data read clock I/O pin. I/O polarity selectable by command.	Schmitt input
10	DA TA	O 3-5I/F	Subcode P-W data output pin.	



Pin No.	Symbol	I/O	Function Description	Remarks								
11	S FSY	O 3-5I/F	Playback frame sync signal output pin.									
12	S BSY	O 3-5I/F	Subcode block sync signal output pin. "H" level at S1 when subcode sync is detected.									
13	I O0	I/O 3-5I/F	General-purpose input / output pins. Input port at reset.	Schmitt at input								
14	I O1											
15	P VDD3		PLL-only 3.3 V power supply voltage pin.									
16	P DO	O A/I/F	EFM and PLCK phase difference signal output pin.	4-state output (PVDD3, HiZ, PVREF, AVSS3)								
17	TM AX	O A/I/F	TMAX detection result output pin. <table border="1" style="margin: 10px auto; border-collapse: collapse;"> <thead> <tr> <th>TMAX Detection Result</th> <th>TMAX Output</th> </tr> </thead> <tbody> <tr> <td>Longer than fixed period</td> <td>"PVDD3"</td> </tr> <tr> <td>Within fixed period</td> <td>"HiZ"</td> </tr> <tr> <td>Shorter than fixed period</td> <td>"AVSS3"</td> </tr> </tbody> </table>	TMAX Detection Result	TMAX Output	Longer than fixed period	"PVDD3"	Within fixed period	"HiZ"	Shorter than fixed period	"AVSS3"	3-state output (PVDD3, HiZ, AVSS3)
TMAX Detection Result	TMAX Output											
Longer than fixed period	"PVDD3"											
Within fixed period	"HiZ"											
Shorter than fixed period	"AVSS3"											
18	LP FN	I A/I/F	Inverted input pin for PLL LPF amp.	Analog input								
19	LP FO	O A/I/F	Output pin for PLL LPF amp.	Analog output								
20	P VREF		PLL-only VREF pin.									
21	V COF	O A/I/F	VCO filter pin.	Analog output								
22	A VSS3		Analog GND pin.									
23	S LCO	O A/I/F	DAC output pin for data slice level generation.	Analog output								
24	RFI	I A/I/F	RF signal input pin. Zin selectable by command.	Analog input								
25	A VDD3		Analog 3.3 V power supply voltage pin.									
26	RF CT	I A/I/F	RFRP signal center level input pin.	Analog input: Zin 33 k								
27	RFZI	I A/I/F	RFRP signal zero-cross input pin.	Analog input								
28	RFRP	I A/I/F	RF ripple signal input pin.	Analog input								
29	FE I	I A/I/F	Focus error signal input pin.	Analog input								
30	S BAD	I A/I/F	Sub-beam adder signal input pin.	Analog input								
31	TE I	I A/I/F	Tracking error input pin. Inputs when tracking servo is on.	Analog input								
32	TE ZI	I A/I/F	Tracking error signal zero-cross input pin.	Analog input: Zin 10 k								
33	FOO	O A/I/F	Focus equalizer output pin.	Analog output (AVSS3~AVDD3)								
34	TRO	O A/I/F	Tracking equalizer output pin.									
35	V REF		Analog reference power supply voltage pin.									
36	RFGC	O A/I/F	RF amplitude adjustment control signal output pin.	3-state output (PWM carrier 88.2 kHz) (AVDD3, VREF, AVSS3)								
37	TE BC	O A/I/F	Tracking balance control signal output pin.									

Pin No.	Symbol	I/O	Function Description	Remarks
38	S EL	O AI/F	APC circuit ON/OFF signal output pin. At laser on, high impedance with UHS "L", H output with UHS "H".	3-state output
39	A V <sub>DD3</sub>		Analog 3.3 V power supply voltage pin.	
40	FM O	O AI/F	Feed equalizer output pin.	3-state output (PWM carrier 88.2 kHz) (AV <sub>DD3</sub> , V <sub>REF</sub> , AV <sub>SS3</sub> )
41	DM O	O AI/F	Disc equalizer output pin.	
42	V <sub>SS3</sub>		Digital GND pin.	
43	V <sub>DD3</sub>		Digital 3.3 V power supply voltage pin.	
44	TE SIN	I 3I/F	Test input pin. Normally, fixed to "L".	
45	X V <sub>SS3</sub>		System clock oscillator GND pin.	
46	X I	I AI/F	System clock oscillator input pin.	
47	X O	O AI/F	System clock oscillator output pin.	
48	X V <sub>DD3</sub>		System clock oscillator 3.3 V power supply voltage pin.	
49	DV <sub>SS3</sub>		DA converter GND pin.	
50	RO	O AI/F	R-channel data forward output pin.	
51	DV <sub>DD3</sub>		DA converter 3.3 V power supply pin.	
52	DV <sub>R</sub>		Reference voltage pin.	
53	LO	O AI/F	L-channel data forward output pin.	
54	DV <sub>SS3</sub>		DA converter GND pin.	
55	ZDE T	O 3-5I/F	1 bit DA converter zero data detection flag output pin.	
56	V <sub>SS5</sub>		Microcontroller interface GND pin.	
57	B <sub>US0</sub>	I/O 3-5I/F	Microcontroller interface data I/O pins.	Schmitt input CMOS ports
58	B <sub>US1</sub>			
59	B <sub>US2</sub>			
60	B <sub>US3</sub>			
61	B <sub>UCK</sub>	I 3-5I/F	Microcontroller interface clock input pin.	Schmitt input
62	/ CCE	I 3-5I/F	Microcontroller interface chip enable signal input pin. At "L", BUS0 to BUS3 are active.	Schmitt input
63	/ RST	I 3-5I/F	Reset signal input pin. At reset, "L".	Built-in pull-up resistor
64	V <sub>DD5</sub>		Microcontroller interface 5 V power supply pin.	

Note: AI/F: analog input/output pin  
3-5I/F: 3-5 interface built-in pin (5 V input/output pin)  
3I/F: 3 V input/output pin

## PCM1791ADBR (IC 71)

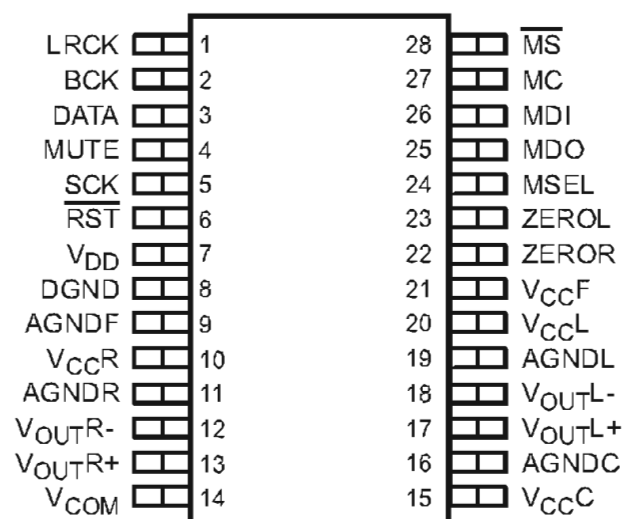

## FUNCTIONAL BLOCK DIAGRAM

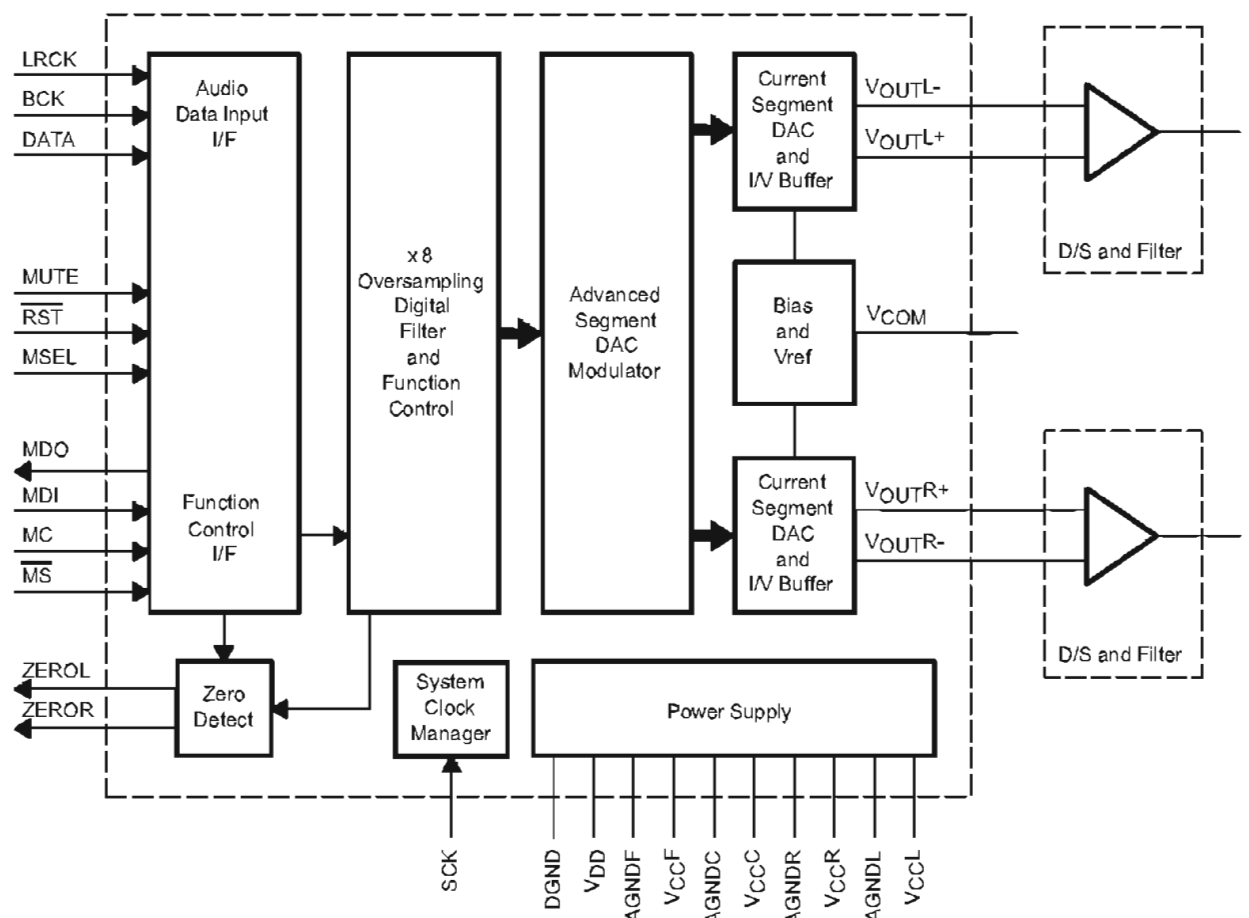

## Terminal Functions

TERMINAL NAME	PIN	I/O	DESCRIPTIONS
AGNDC	16	-	Analog ground (internal bias and current DAC)
AGNDF	9	-	Analog ground (DACFF)
AGNDL	19	-	Analog ground (L-channel I/V)
AGNDR	11	-	Analog ground (R-channel I/V)
BCK	2	I	Bit clock input (1)
DATA	3	I	Serial audio data input (1)
DGND	8	-	Digital ground
LRCK	1	I	Left and right clock ( $f_S$ ) input (1)
MC	27	I	Mode control clock input (1)
MDI	26	I/O	Mode control data input (2)
MDO	25	O	Mode control readback data output (3)
MS	28	I/O	Mode control chip select input (4)
MSEL	24	I	I <sup>2</sup> C/SPI select (1)
MUTE	4	I	Analog output mute control (1)
RST	6	I	Reset (1)
SCK	5	I	System clock input (1)
VCC	15	-	Analog power supply (internal bias and current DAC), 5 V
VCCF	21	-	Analog power supply (DACFF), 5 V
VCCL	20	-	Analog power supply (L-channel I/V), 5 V
VCCR	10	-	Analog power supply (R-channel I/V), 5 V
VCOM	14	-	Internal bias decoupling pin
VDD	7	-	Digital power supply, 3.3 V
VOUTL+	17	O	L-channel analog voltage output +
VOUTL-	18	O	L-channel analog voltage output -
VOUTR+	13	O	R-channel analog voltage output +
VOUTR-	12	O	R-channel analog voltage output -
ZEROL	23	O	Zero flag for L-channel
ZEROR	22	O	Zero flag for R-channel

(1) Schmitt-trigger input, 5-V tolerant

(2) Schmitt-trigger input and output. 5-V tolerant input. In I<sup>2</sup>C mode, this pin becomes an open-drain 3-state output; otherwise, this pin is a CMOS output.

(3) 3-state output

(4) Schmitt-trigger input and output. 5-V tolerant input and CMOS output

TA2125AFG (IC 51)

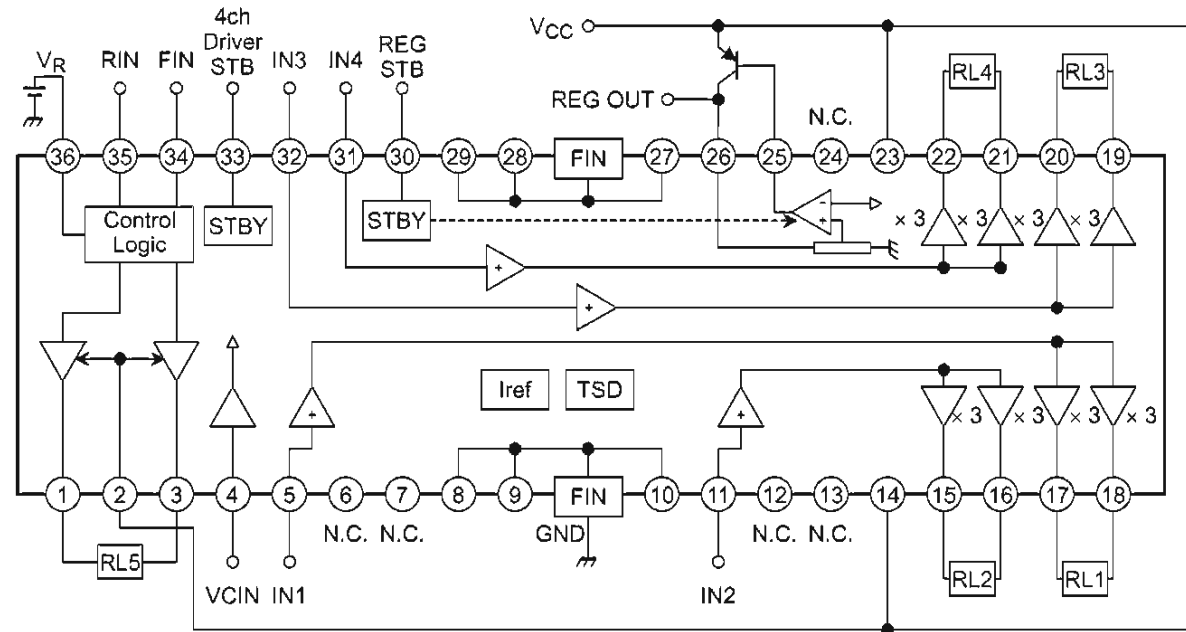

TA2125AF Terminal Function

No.	Symbol	Function	
1	OUT5A	Output terminal	H-bridge
2	V <sub>M</sub>	Supply voltage terminal for Logic	H-bridge
3	OUT5B	Output terminal	H-bridge
4	V <sub>CIN</sub>	Input reference voltage	4ch BTL
5	IN1	Input for ch1	4ch BTL
6	N.C.	Open	—
7	N.C.	Open	—
8	N.C.	8, 9, 10, 27, 28, 29 are connected to PW GND (FIN)	—
9	N.C.	8, 9, 10, 27, 28, 29 are connected to PW GND (FIN)	—
10	N.C.	8, 9, 10, 27, 28, 29 are connected to PW GND (FIN)	—
11	IN2	Input for ch2	4ch BTL
12	N.C.	Open	—
13	N.C.	Open	—
14	V <sub>CC1</sub>	Supply voltage terminal for ch1/ch2	4ch BTL
15	OUT2M	Inverted output for ch2	4ch BTL
16	OUT2P	Non-inverted output for ch2	4ch BTL
17	OUT1M	Inverted output for ch1	4ch BTL
18	OUT1P	Non-inverted output for ch1	4ch BTL
19	OUT3P	Non-inverted output for ch3	4ch BTL
20	OUT3M	Inverted output for ch3	4ch BTL
21	OUT4P	Non-inverted output for ch4	4ch BTL
22	OUT4M	Inverted output for ch4	4ch BTL
23	V <sub>CC2</sub>	Supply voltage terminal for ch3/ch4	4ch BTL
24	N.C.	Open	—
25	REG	Connection with BASE of PNP Tr	Regulator
26	REG OUT	Output for regulator (5 V)	Regulator
27	N.C.	8, 9, 10, 27, 28, 29 are connected to PW GND (FIN)	—
28	N.C.	8, 9, 10, 27, 28, 29 are connected to PW GND (FIN)	—
29	N.C.	8, 9, 10, 27, 28, 29 are connected to PW GND (FIN)	—
30	REG STBY	Standby control for regulator	Regulator
31	IN4	Input for ch4	4ch BTL
32	IN3	Input for ch3	4ch BTL
33	STBY	Standby control for 4ch BTL	4ch BTL
34	FIN	Logic control input	H-bridge
35	RIN	Logic control input	H-bridge
36	VR	Supply voltage terminal for motor driver	H-bridge

TA2157FNG (IC 52)

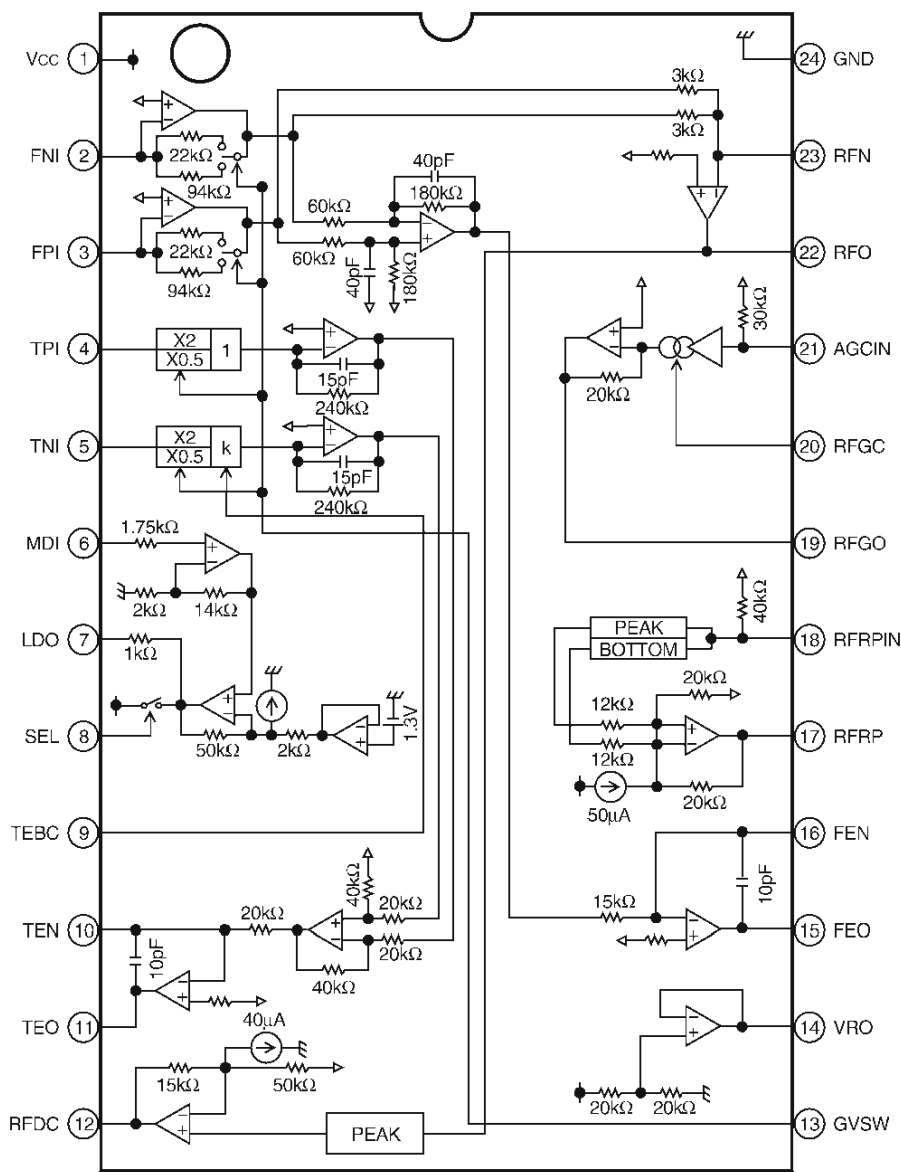

TA2157F Terminal Function

Pin No.	Symbol	I/O	Description	Voltage (V)
1	Vcc	—	3.3 power pin	3.3
2	FNI	I	Main beam amp input	1.65
3	FPI	I	Main beam amp input	1.65
4	TPI	I	Sub beam amp input	1.65
5	TNI	I	Sub beam amp input	1.65
6	MDI	I	Monitor photo diode amp input	0
7	LDO	O	Laser diode amp output	2.67
8	SEL	I	APC on/off sig., LDO pin cont. input and bottom/peak detect f switching	1.65
9	TEBC	I	Tracking error bal. sig. input	1.75
10	TEN	I	Tracking error sig. gen. amp (-) input	1.65
11	TEO	O	Tracking error sig. gen. amp output	1.65
12	RFDC	O	RF sig. peak detection output	1.5
13	GVSW	I	AGC, FE, TE amp gain switching	2.1
14	VRO	O	Ref. V (VRO) output	1.65
15	FEO	O	Focus error sig. gen. amp output	1.65
16	FEN	I	Focus error sig. gen. amp (-) input	1.65
17	RFRP	O	Tracking count sig. gen. amp output	0.75
18	RFRPIN	I	Tracking count sig. gen. amp input	1.65
19	RFGO	O	RF sig. amplitude adj. amp output	1.23
20	RFGC	I	RF amplitude adj. cont. sig. input	1.62
21	AGCIN	I	RF sig. amplitude adj. amp input	2.39
22	RFO	O	RF sig. gen. amp output	1.1
23	RFN	I	RF sig. gen. amp input	1.65
24	GND	—	GND pin	0

## 2. FL DISPLAY HCA-13SS21 (FL 21)

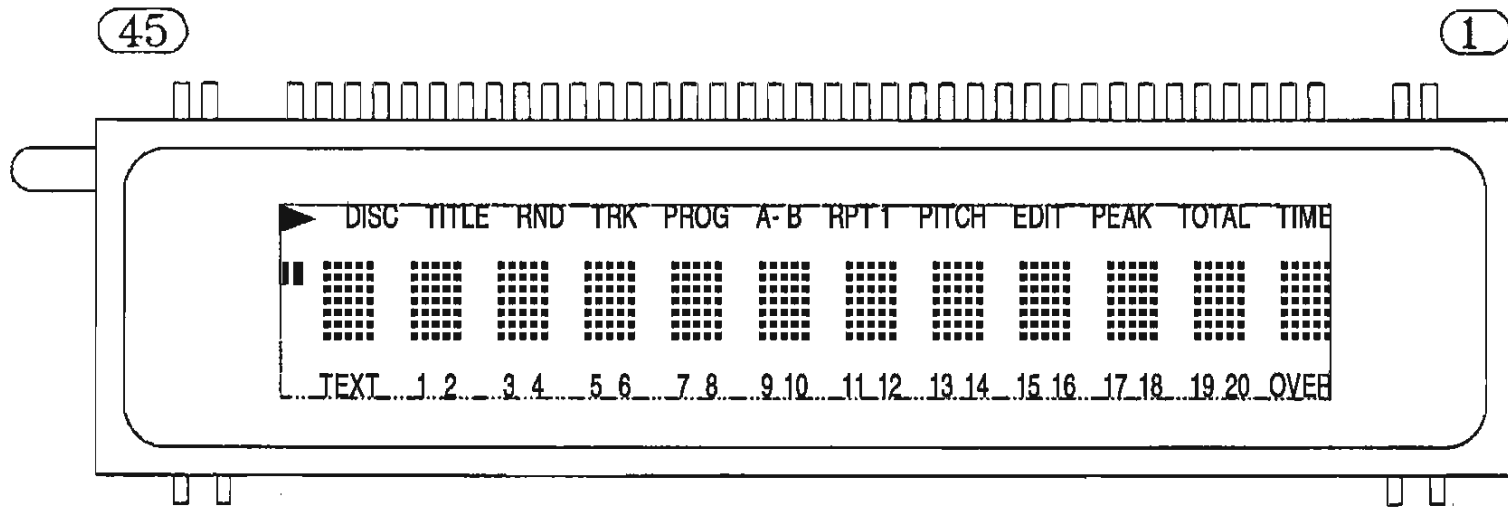

### Pin Connection

PIN NO.	45	44	43	42	41~17	16	15	14	13	12	11	10	9	8	7	6	5	4	3	2	1
CONNECTION	F2	F2	NP	NP	NX	13G	NC	GR13	VDD	DIN	CLKB	CSB	RSTB	OSCO	OSCI	VEE	GND	NP	NP	F1	F1

•Notes•

- 1) Fn : Filament Pin
- 2) NP : No Pin
- 3) NX : No Extended pin
- 3) NC : No Connection

### Grid Assignment

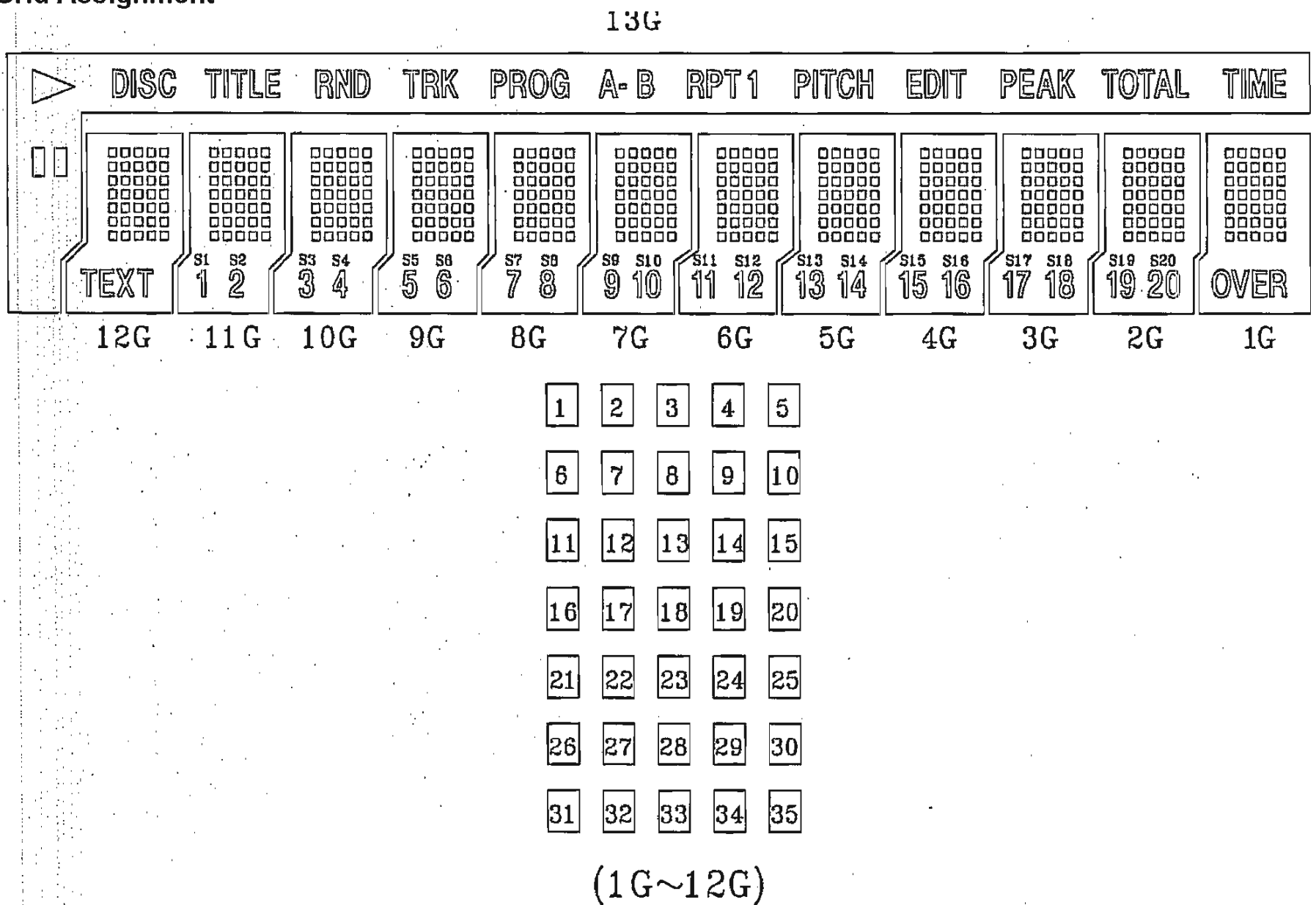

Anode Connection

	GR1	GR2	GR3	GR4	GR5	GR6	GR7	GR8	GR9	GR10	GR11	GR12	GR13
	1G	2G	3G	4G	5G	6G	7G	8G	9G	10G	11G	12G	13G
SG1	1	1	1	1	1	1	1	1	1	1	1	1	TIME
SG2	2	2	2	2	2	2	2	2	2	2	2	2	TOTAL
SG3	3	3	3	3	3	3	3	3	3	3	3	3	PEAK
SG4	4	4	4	4	4	4	4	4	4	4	4	4	EDIT
SG5	5	5	5	5	5	5	5	5	5	5	5	5	PYCH
SG6	6	6	6	6	6	6	6	6	6	6	6	6	
SG7	7	7	7	7	7	7	7	7	7	7	7	7	RPT
SG8	8	8	8	8	8	8	8	8	8	8	8	8	B
SG9	9	9	9	9	9	9	9	9	9	9	9	9	A
SG10	10	10	10	10	10	10	10	10	10	10	10	10	PROG
SG11	11	11	11	11	11	11	11	11	11	11	11	11	TRK
SG12	12	12	12	12	12	12	12	12	12	12	12	12	RND
SG13	13	13	13	13	13	13	13	13	13	13	13	13	TITLE
SG14	14	14	14	14	14	14	14	14	14	14	14	14	DISC
SG15	15	15	15	15	15	15	15	15	15	15	15	15	
SG16	16	16	16	16	16	16	16	16	16	16	16	16	
SG17	17	17	17	17	17	17	17	17	17	17	17	17	
SG18	18	18	18	18	18	18	18	18	18	18	18	18	
SG19	19	19	19	19	19	19	19	19	19	19	19	19	
SG20	20	20	20	20	20	20	20	20	20	20	20	20	
SG21	21	21	21	21	21	21	21	21	21	21	21	21	
SG22	22	22	22	22	22	22	22	22	22	22	22	22	
SG23	23	23	23	23	23	23	23	23	23	23	23	23	
SG24	24	24	24	24	24	24	24	24	24	24	24	24	
SG25	25	25	25	25	25	25	25	25	25	25	25	25	
SG26	26	26	26	26	26	26	26	26	26	26	26	26	
SG27	27	27	27	27	27	27	27	27	27	27	27	27	
SG28	28	28	28	28	28	28	28	28	28	28	28	28	
SG29	29	29	29	29	29	29	29	29	29	29	29	29	
SG30	30	30	30	30	30	30	30	30	30	30	30	30	
SG31	31	31	31	31	31	31	31	31	31	31	31	31	
SG32	32	32	32	32	32	32	32	32	32	32	32	32	
SG33	33	33	33	33	33	33	33	33	33	33	33	33	
SG34	34	34	34	34	34	34	34	34	34	34	34	34	
SG35	35	35	35	35	35	35	35	35	35	35	35	35	
AD1	OVER	S19	S17	S15	S13	S11	S9	S7	S5	S3	S1	TEXT	
AD2		S20	S18	S16	S14	S12	S10	S8	S6	S4	S2		

PRINTED WIRING BOARDS

MAIN P.W.B. UNIT (1/2)

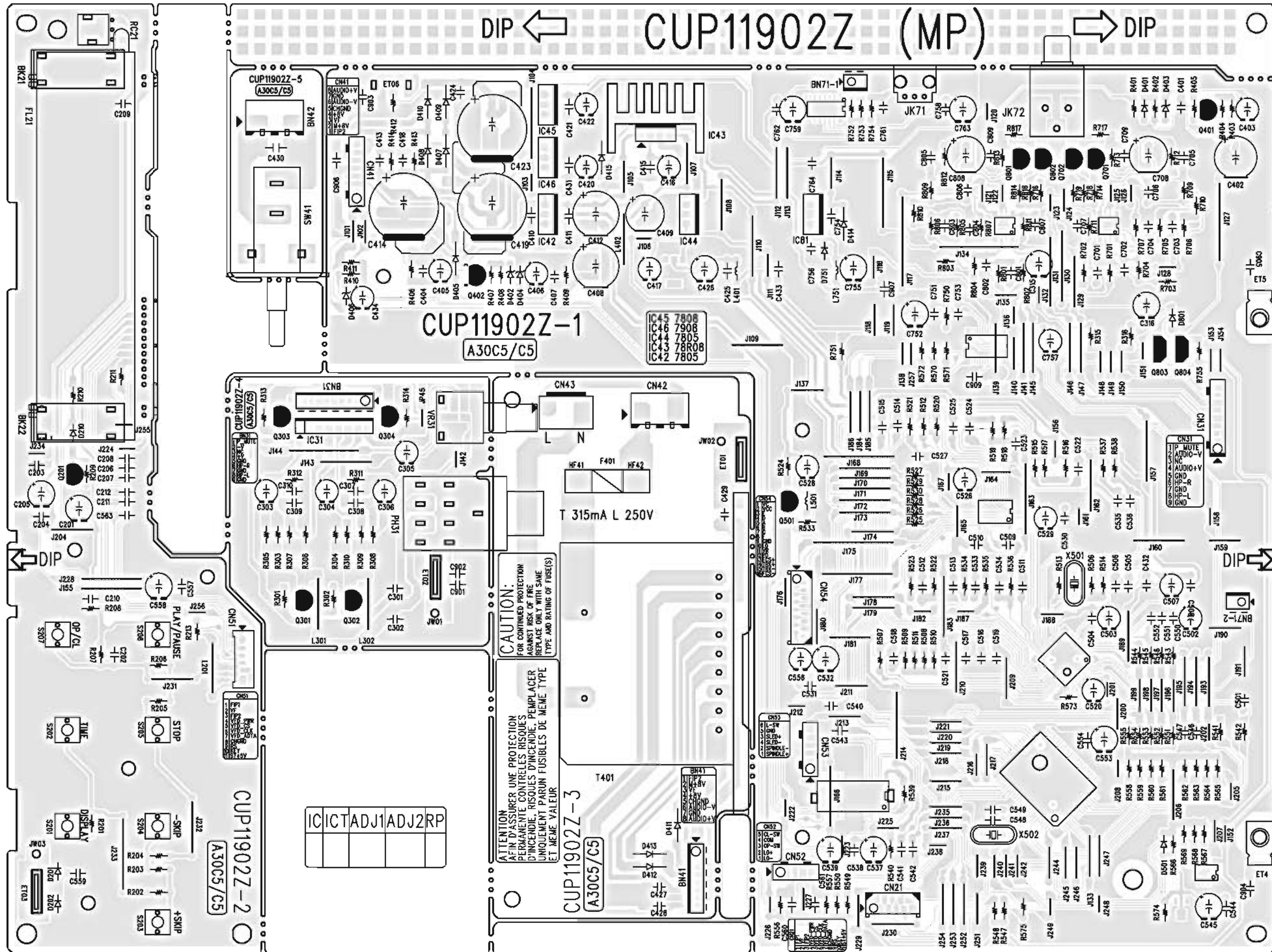

COMPONENT SIDE



MAIN P.W.B. UNIT (2/2)

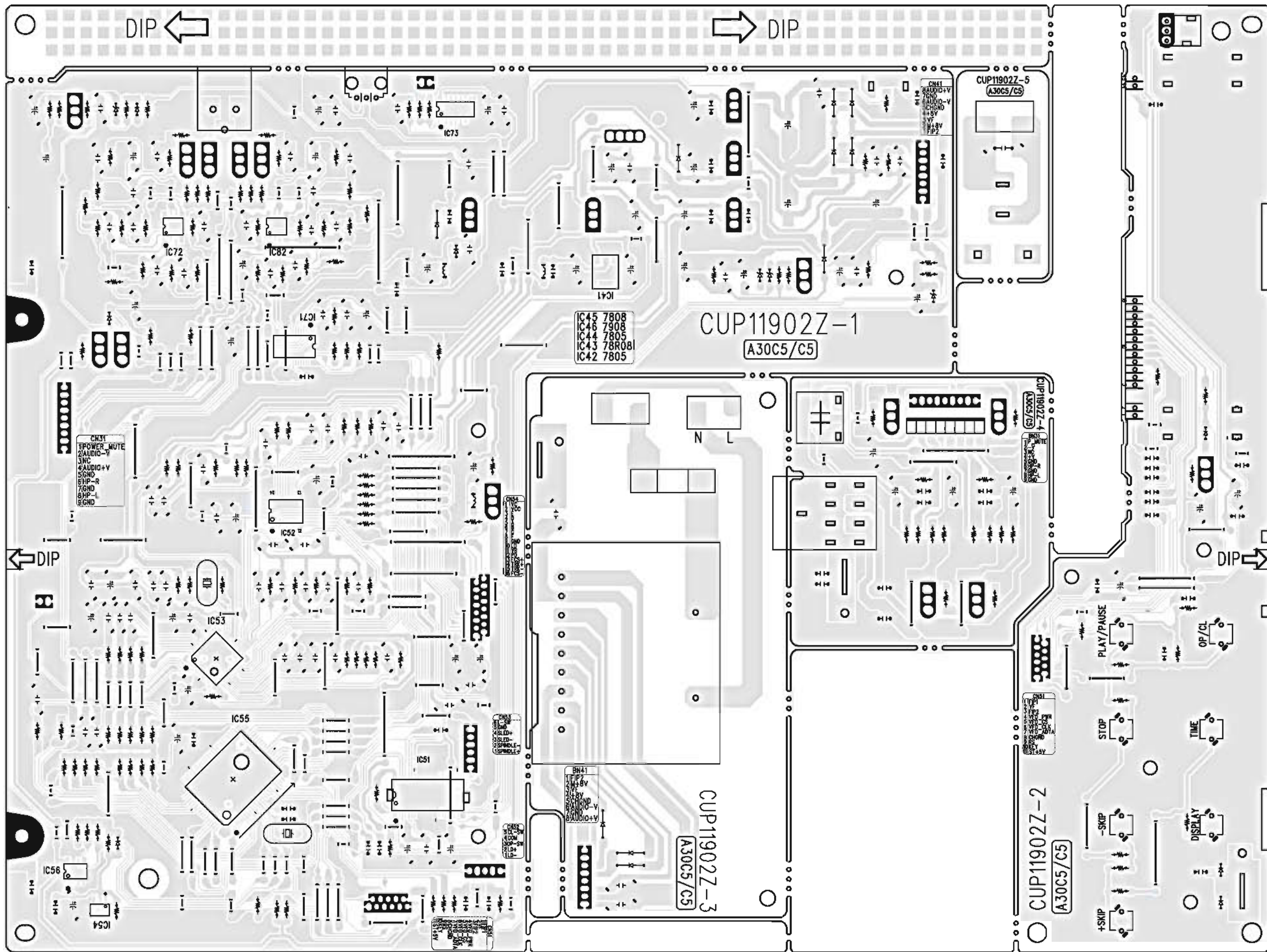

FOIL SIDE

# NOTE FOR PARTS LIST

- Part indicated with the mark "nsp" are not always in stock and possibly to take a long period of time for supplying, or in some case supplying of part may be refused.
  - When ordering of part, clearly indicate "1" and "I" (i) to avoid mis-supplying.
  - Ordering part without stating its part number can not be supplied.
  - Part indicated with the mark "★" is not illustrated in the exploded view.
  - Not including General-purpose Carbon Film Resistor in the P.W.Board parts list. (Refer to the Schematic Diagram for those parts.)
  - Not including General-purpose Carbon Chip Resistor in the P.W.Board parts list. (Refer to the Schematic Diagram for those parts.)
- WARNING:**  
Parts marked with this symbol  $\Delta$  have critical characteristics.  
Use ONLY replacement parts recommended by the manufacturer.

## ● Resistors

Ex.: RN 14K 2E 182 G FR  
 Type Shape Power Resist- Allowable Others  
 and per- error  
 performance

RD Carbon	2B 1/8W	F ±1%	P Pulse-resistant type
RC Composition	2E 1/4W	G ±2%	NL Low noise type
RS Metal oxide film	2H 1/2W	J ±5%	NB Non-burning type
RW Winding	3A 1W	K ±10%	FR Fuse-resistor
RN Metal film	3D 2W	M ±20%	F Lead wire forming
RK Metal mixture	3F 3W		
	3H 5W		

### \* Resistance

1 8 2 ⇒ 1800 ohm = 1.8 kohm  
 Indicates number of zeros after effective number.  
 2-digit effective number.  
 • Units: ohm

1 R 2 ⇒ 1.2 ohm  
 1-digit effective number.  
 2-digit effective number, decimal point indicated by R.  
 • Units: ohm

## ● Capacitors

Ex.: CE 04W 1H 2R2 M BP  
 Type Shape Dielectric Capacity Allowable Others  
 and per- strength error  
 performance

CE Aluminum foil electrolytic	0J 6.3V	F ±1%	HS High stability type
CA Aluminum solid electrolytic	1A 10V	G ±2%	BP Non-polar type
CS Tantalum electrolytic	1C 16V	J ±5%	HR Ripple-resistant type
CQ Film	1E 25V	K ±10%	DL For charge and discharge
CK Ceramic	1V 35V	M ±20%	HF For assuring high frequency
CC Ceramic	1H 50V	Z +80%	U UL part
CP Oil	2A 100V	-20%	C CSA part
CM Mica	2B 125V	P +100%	W UL-CSA type
CF Metallized	2C 160V	-0%	F Lead wire forming
CH Metallized	2D 200V	C ±0.25pF	
	2E 250V	D ±0.5pF	
	2H 500V	= Others	
	2J 630V		

### \* Capacity (electrolyte only)

2 2 2 ⇒ 2200μF  
 Indicates number of zeros after effective number.  
 2-digit effective number.  
 • Units: μF.

2 R 2 ⇒ 2.2μF  
 1-digit effective number.  
 2-digit effective number, decimal point indicated by R.  
 • Units: μF.

### \* Capacity (except electrolyte)

2 2 2 ⇒ 2200pF=0.0022μF  
 (More than 2) Indicates number of zeros after effective number.  
 2-digit effective number.  
 • Units: pF.

2 2 1 ⇒ 220pF  
 (0 or 1) Indicates number of zeros after effective number.  
 2-digit effective number.  
 • Units: pF.

● When the dielectric strength is indicated in AC, "AC" is included after the dielectric strength value.

# 部品表について

1. nsp 印の部品は常時在庫していませんので供給に長時間を要することがあります。場合によっては、供給をお断りすることがあります。
2. 部品を発注する際は特に数字の "1" と英字の "I" との区別をはっきり記入してください。
3. 部品番号を表示していない部品は供給できません。
4.  $\Delta$ 印の部品は安全上重要な部品です。交換するときは、安全および性能維持のため必ず指定の部品をご使用ください。
5. ★印のついている部品は分解図中には記載していません。
6. 汎用カーボン抵抗器は記載していません。定数は回路図を参照願います。
7. 汎用カーボンチップ抵抗器は記載していません。定数は回路図を参照願います。
8. 部品表の抵抗器、コンデンサの品名記号の読み方は表を参照してください。

## ● 抵抗器

例) RN 14K 2E 182 G FR  
 種類 形状特性 電力 抵抗値 許容差 その他

RD : カーボン	2B : 1/8 W	F : ±1%	P : 耐パルス形
RC : 固定体	2E : 1/4 W	G : ±2%	NL : 低雑音形
RS : 金属系皮膜	2H : 1/2 W	J : ±5%	NB : 不燃形
RW : 芯線	3A : 1 W	K : ±10%	FR : ヒューズ抵抗
RN : 金属皮膜	3D : 2 W	M : ±20%	F : リード線成形
RK : 金属混合体	3F : 3 W		
	3H : 5 W		

### \* 抵抗値

18 2 ⇒ 1800Ω=1.8kΩ  
 有効数字につづく0の数を表わす。  
 2桁の有効数字を表わす。  
 ;単位はΩ

1R 2 ⇒ 1.2Ω  
 1桁の有効数字を表わす。  
 2桁の有効数字で小数点はRで表わす。  
 ;単位はΩ

## ● コンデンサ

例) CE 04W 1H 2R2 M BP  
 種類 形状特性 耐圧 容量 許容差 その他

CE : アルミ箔電解	0J : 6.3 V	F : ±1%	HS : 高安定形
CA : アルミ固体電解	1A : 10 V	G : ±2%	BP : 無極性形
CS : タンタル電解	1C : 16 V	J : ±5%	HR : 耐リップル形
CQ : フィルム	1E : 25 V	K : ±10%	DL : 充放電対策用
CK : セラミック	1V : 35 V	M : ±20%	HF : 高周波保証用
CC : セラミック	1H : 50 V	Z : +80%	U : UL 部品
CP : オイル	2A : 100 V	-20%	C : CSA 部品
CM : マイカ	2B : 125 V	P : +100%	W : UL-CSA 部品
CF : メタライズド	2C : 160 V	-0%	F : リード線成形
CH : メタライズド	2D : 200 V	C : ±0.25pF	
	2E : 250 V	D : ±0.5pF	
	2H : 500 V	= : その他	
	2J : 630 V		

### \* 容量値

#### ● 電解コンデンサの場合

22 2 ⇒ 2200μF  
 有効数字につづく0の数を表わす。  
 2桁の有効数字を表わす。  
 ;単位はμF

2R 2 ⇒ 2.2μF  
 1桁の有効数字を表わす。  
 2桁の有効数字で小数点はRで表わす。  
 ;単位はμF

#### ● 電解コンデンサ以外の場合

22 2 ⇒ 2200pF=0.0022μF  
 有効数字につづく0の数を表わす。  
 (0の数が2以上の場合)  
 2桁の有効数字を表わす。  
 ;単位はpF

22 1 ⇒ 220pF  
 有効数字につづく0の数を表わす。  
 (0の数が0または1の場合)  
 2桁の有効数字を表わす。  
 ;単位はpF

● 耐圧を交流で表示する場合は、耐圧表示の次に「AC」を表示します。

## PARTS LIST OF P.W.B. UNIT

\* 本表に記載されている部品は、補修用部品のため製品に使用している部品とは一部、形状、寸法などが異なる場合があります。

\* The parts listed below are for maintenance only, might differ from the parts used in the unit in appearances or dimensions.

\* "nsp" 印の部品は常時在庫していませんので供給に長時間を要することがあります。場合によっては、供給をお断りする場合があります。

\* Part indicated with the mark "nsp" are not always in stock and possibly to take a long period of time for supplying, or in some case supplying of part may be refused.

**Note:** The symbols in the column "Remarks" indicate the following destinations.

E2 : Europe model

EUT : Taiwan R.O.C. model





### MAIN P.W.B. UNIT ASSY

Ref. No.	nsp	Part No.	Part Name	Remark	Q'ty	New
<b>SEMICONDUCTORS GROUP</b>						
IC31		00D 943 0059 800	I.C NJM4556AL			
IC41		00D 943 0038 902	I.C 1117S-3.3V			
IC42		00D 943 0184 005	I.C KA7805-ABTU			
IC43		00D 943 0183 802	I.C REGULATOR			
IC44		00D 943 0184 005	I.C KA7805-ABTU			
IC45		00D 943 0183 705	I.C KIA7812API			
IC46		00D 943 0183 909	I.C KA7912PI			
IC51		00D 943 0184 209	I.C TA2125AFG (Pb Free)			
IC52		00D 943 0184 306	I.C TA2157FNG (Pb Free)			
IC53		00D 943 0184 403	I.C TC94A14FAG (Pb Free)			
IC54		00D 943 0184 102	I.C RH5VT28C			
IC55		00D 943 0184 500	I.C TMP87PS71AFG (Pb Free)			
IC56		00D 943 0182 900	I.C AT24C02NSU18			
IC71		00D 262 3332 904	I.C PCM1791ADBR			
IC72		00D 943 0007 108	I.C NJM2068MD-TE1			
IC73		00D 943 0183 608	I.C 74HCU04AFNG			
IC81		00D 943 0184 005	I.C KA7805-ABTU			
IC82		00D 943 0007 108	I.C NJM2068MD-TE1			
Q201		00D 943 0155 306	T.R KTD1302			
Q301-304		00D 943 0155 306	T.R KTD1302			
Q401		00D 943 0128 702	T.R TKTA1266YT			
Q402		00D 943 0184 908	T.R KTA1271Y			
Q501		00D 943 0128 702	T.R TKTA1266YT			
Q701-702		00D 943 0155 306	T.R KTD1302			
Q801-802		00D 943 0155 306	T.R KTD1302			
Q803		00D 943 0004 305	T.R KRC107M			
Q804		00D 943 0184 607	T.R KRA104M			
D201,202		00D 943 0182 609	DIODE 1SS133			
D210		00D 943 0182 609	DIODE 1SS133			
D401		00D 943 0182 609	DIODE 1SS133			
D402		00D 943 0185 004	DIODE ZJ15BT			
D403		00D 943 0185 101	DIODE ZJ4.7BT			
D404		00D 943 0185 004	DIODE ZJ15BT			
D405		00D 943 0182 502	DIODE 1N4003			
D406		00D 943 0182 803	DIODE ZJ6.2BT			
D407-413		00D 943 0182 502	DIODE 1N4003			
D414,415		00D 943 0185 208	DIODE 1N5819			
D501,502		00D 943 0182 609	DIODE 1SS133			
D751		00D 943 0182 609	DIODE 1SS133			
D801		00D 943 0182 609	DIODE 1SS133			
<b>CAPACITORS GROUP</b>						
C201		-	C. ELECT 47UF 16V			
C202		-	C. CERAMIC 0.1UF 50V ZF			
C203		-	C. CERAMIC 1000PF 50V KB			
C204		-	C. CERAMIC 0.1UF 50V ZF			
C205		-	C. ELECT 47UF 16V			

Ref. No.	nsp	Part No.	Part Name	Remark		Q'ty	New
C206,207		-	C. CERAMIC 47PF 50V J		HCBS1H470JT		
C208,209		-	C. CERAMIC 0.1UF 50V ZF		HCBS1H104ZFT		
C210-212		-	C. CERAMIC 47PF 50V J		HCBS1H470JT		
C301,302		-	C. CERAMIC 2200PF 50V KB		HCBS1H222KBT		
C303		-	C. ELEC 100uF/50V		CCEA1HRFO101T		
C304,305		-	C. ELECT 100UF 16V		CCEA1CH101T		
C306		-	C. ELEC 100uF/50V		CCEA1HRFO101T		
C307		-	C. CERAMIC 150PF 50V KB		HCBS1H151KBT		
C308,309		-	C. CERAMIC 220PF 50V KB		HCBS1H221KBT		
C310		-	C. CERAMIC 150PF 50V KB		HCBS1H151KBT		
C315,316		-	C. ELECT 47UF 50V		CCEA1HH470T		
C401		-	C. CERAMIC 1000PF 50V KB		CCKT1H102KB		
C402		-	C. ELECT 1000UF 16V		CCEA1CH102E		
C403		-	C. ELECT 0.1UF 50V		CCEA1HH0R1T		
C404		-	C. SEMI 0.1UF 50V ZF		CCFT1H104ZF		
C405		-	C. ELECT 10UF 50V		CCEA1HH100T		
C406		-	C. ELECT 2.2UF 50V		CCEA1HH2R2T		
C407		-	C. SEMI 0.1UF 50V ZF		CCFT1H104ZF		
C408		-	C. ELECT 22UF 63V		CCEA1JH220T		
C409		-	C. ELECT 470UF 16V		CCEA1CH471T		
C410,411		-	C. CERAMIC 0.1UF 50V ZF		HCBS1H104ZFT		
C412		-	C. ELECT 470UF 25V		CCEA1EH471T		
C413		-	C. SEMI 0.1UF 50V ZF		CCFT1H104ZF		
C414		00D 943 0185 305	C. ELEC 25V/3300uF ELNA RFO		CCEA1ERFO332T		
C415		-	C. SEMI 0.1UF 50V ZF		CCFT1H104ZF		
C416,417		-	C. ELECT 100UF 16V		CCEA1CH101T		
C418		-	C. SEMI 0.1UF 50V ZF		CCFT1H104ZF		
C419		00D 943 0185 305	C. ELEC 25V/3300uF ELNA RFO		CCEA1ERFO332T		
C420		-	C. ELECT 100UF 16V		CCEA1CH101T		
C421		-	C. CERAMIC 0.1UF 50V ZF		HCBS1H104ZFT		
C422		-	C. ELECT 100UF 16V		CCEA1CH101T		
C423		00D 943 0185 305	C. ELEC 25V/3300uF ELNA RFO		CCEA1ERFO332T		
C424		-	C. SEMI 0.1UF 50V ZF		CCFT1H104ZF		
C425		-	C. CERAMIC 0.1UF 50V ZF		HCBS1H104ZFT		
C426		-	C. ELECT 47UF 16V		CCEA1CH470T		
C427-429		-	C. SEMI 0.1UF 50V ZF		CCFT1H104ZF		
C430		-	C. CERAMIC 0.0047UF/2.5KV		KCKDKS472ME		
C431		-	C. CERAMIC 0.1UF 50V ZF		HCBS1H104ZFT		
C432		-	C. SEMI 0.1UF 50V ZF		CCFT1H104ZFT		
C433		-	C. CERAMIC 0.1UF 50V ZF		HCBS1H104ZFT		
C501		-	C. SEMI 0.1UF 50V ZF		CCFT1H104ZF		
C502,503		-	C. ELECT 100UF 16V		CCEA1CH101T		
C504		-	C. SEMI 0.1UF 50V ZF		CCFT1H104ZF		
C505,506		-	C. CERAMIC 10PF 50V DC		CCCT1H100DC		
C507		-	C. ELECT 100UF 16V		CCEA1CH101T		
C508		-	C. SEMI 0.1UF 50V ZF		CCFT1H104ZF		
C509-511		-	C. CERAMIC 0.047UF 50V ZF		CCFT1H473ZF		
C512		-	C. CERAMIC 6800PF 50V KB		CCKT1H682KB		
C513,514		-	C. CERAMIC 0.033UF 50V ZF		CCFT1H333ZF		
C515		-	C. SEMI 0.1UF 50V ZF		CCFT1H104ZF		
C516		-	C. CERAMIC 2700PF 50V KB		CCKT1H272KB		
C517		-	CAP, CERAMIC 0.01UF 50V ZF		CCFT1H103ZF		
C518		-	C. CERAMIC 0.015UF 50V ZF		CCKT1H153ZF		
C519		-	C. SEMI 0.1UF 50V ZF		CCFT1H104ZF		
C520		-	C. ELECT 100UF 16V		CCEA1CH101T		
C521		-	C. CERAMIC 47PF 50V JC		CCCT1H470JC		
C522		-	C. CERAMIC 68PF 50V JC		CCCT1H680JC		
C523		-	C. CERAMIC 5PF 50V CC		CCCT1H050CC		
C524,525		-	C. SEMI 0.1UF 50V ZF		CCFT1H104ZF		
C526		-	C. ELECT 100UF 16V		CCEA1CH101T		
C527		-	C. SEMI 0.1UF 50V ZF		CCFT1H104ZF		

Ref. No.	nsp	Part No.	Part Name	Remark		Q'ty	New
C528,529 C530,531 C532		-	C. ELECT 100UF 16V C. SEMI 0.1UF 50V ZF C. ELECT 47UF 16V		CCEA1CH101T CCFT1H104ZF CCEA1CH470T		
C533,534 C535,536 C537 C538 C539		-	C. CERAMIC 470PF 50V KB C. CERAMIC 0.047UF 50V ZF C. ELECT 47UF 16V C. SEMI 0.1UF 50V ZF C. ELECT 220UF 16V		CCKT1H471KB CCKT1H473ZF CCEA1CH470T CCFT1H104ZF CCEA1CH221T		
C540-543 C544 C545 C548,549 C553		-	C. SEMI 0.1UF 50V ZF C. CERAMIC 0.1UF 50V ZF C. ELECT 47UF 16V C. CERAMIC 22PF 50V JC C. ELECT 47UF 10V		CCFT1H104ZF HCBS1H104ZFT CCEA1CH470T CCCT1H220JCT CCEA1AH470T		
C554 C556 C557 C558 C559		-	CAP, CERAMIC 0.01UF 50V ZF C. ELECT 100UF 16V C. CERAMIC 0.1UF 50V ZF C. ELECT 22UF 50V C. CERAMIC 0.1UF 50V ZF		HCBS1H103ZFT CCEA1CH101T HCBS1H104ZFT CCEA1HKS220T HCBS1H104ZFT		
C560,561 C562 C563 C701 C702,703		-	C. SEMI 0.1UF 50V ZF C. ELECT 10UF 50V SMALL C. CERAMIC 0.1UF 50V ZF C. MYLAR 1200PF 50V J C. CERAMIC 220PF 50V KB		CCFT1H104ZFT CCEA1HKS100T HCBS1H104ZFT HCQI1H122JZT CCKT1H221KB		
C704 C705 C706 C707 C708		-	C. SEMI 0.1UF 50V ZF C. MYLAR 1800PF 50V J C. MYLAR 2200PF 50V J C. SEMI 0.1UF 50V ZF C. ELEC 100uF/50V ELNA RFO		CCFT1H104ZF HCQI1H182JZT HCQI1H222JZT CCFT1H104ZF CCEA1HRFO101T		
C709 C751 C752 C753,754 C755		-	C. MYLAR 1800PF 50V J C. SEMI 0.1UF 50V ZF C. ELECT 47UF 16V C. SEMI 0.1UF 50V ZF C. ELEC 100uF/50V ELNA RFO		HCQI1H182JZT CCFT1H104ZF CCEA1CH470T CCFT1H104ZF CCEA1ERFO101T		
C756 C757 C758 C759 C761		-	C. SEMI 0.1UF 50V ZF C. ELECT 1UF 50V C. SEMI 0.1UF 50V ZF C. ELECT 47UF 16V C. CERAMIC 33PF 50V JC		CCFT1H104ZF CCEA1HH1R0T CCFT1H104ZF CCEA1CH470T CCCT1H330JC		
C762 C763 C764 C801 C802,803		-	C. SEMI 0.1UF 50V ZF C. ELECT 47UF 16V C. SEMI 0.1UF 50V ZF C. MYLAR 1200PF 50V J C. CERAMIC 220PF 50V KB		CCFT1H104ZF CCEA1CH470T CCFT1H104ZF HCQI1H122JZT CCKT1H221KB		
C804 C805 C806 C807 C808		-	C. SEMI 0.1UF 50V ZF C. MYLAR 1800PF 50V J C. MYLAR 2200PF 50V J C. SEMI 0.1UF 50V ZF C. ELEC 100uF/50V ELNA RFO		CCFT1H104ZF HCQI1H182JZT HCQI1H222JZT CCFT1H104ZF CCEA1HRFO101T		
C809 C901 C902-907 C909		-	C. MYLAR 1800PF 50V J C. CERAMIC 0.01UF 50V ZF C. CERAMIC 0.1UF 50V ZF C. CERAMIC 0.1UF 50V ZF C. CERAMIC 0.1UF 50V ZF	E2 EUT	HCQI1H182JZT HCBS1H103ZFT HCBS1H104ZFT HCBS1H104ZFT HCBS1H104ZFT		
<b>OTHER PARTS GROUP</b>							
BK21 BK41		-	BRACKET , FIP BRACKET , P.W.B.		CMD1A504 CMD1A387		
BN31 BN41 BN42		00D 943 0185 509 00D 943 0185 606 00D 943 0185 703	WIRE ASS'Y WIRE ASS'Y WIRE ASS'Y		CWZDCD500AEBN31 CWB1D908170EN CWB4D932100UZ		



	Ref. No.	nsp	Part No.	Part Name	Remark		Q'ty	New
	BN71		00D 943 0185 800	SHIELD WIRE ASS'Y		CWZDCD500AEBN71		
	CN21 CN31 CN41 CN42 CN43	nsp nsp nsp nsp nsp	00D 943 0101 402 00D 943 0182 007 00D 943 0182 007 00D 943 0181 804 00D 943 0181 901	WAFER WAFER, STRAIGHT, 9PIN WAFER, STRAIGHT, 8PIN WAFER WAFER		CJP11GA117ZY CJP09GA19ZY CJP08GA19ZY CJP02GA89ZY CJP02KA060ZY		
	CN51 CN52 CN53 CN54	nsp nsp nsp nsp	00D 943 0182 104 00D 943 0182 007 00D 943 0182 007 00D 943 0182 201	WAFER , CARDCABLE WAFER, STRAIGHT, 5PIN WAFER, STRAIGHT, 6PIN WAFER		CJP11GB113ZY CJP05GA19ZY CJP06GA19ZY CJP16GA117ZY		
	ET01,02 ET03 ET4 ET5 ET06	nsp nsp nsp nsp nsp	00D 943 0185 907 00D 943 0186 003 00D 943 0186 100 00D 943 0186 100 00D 943 0186 207	PLATE,EARTH PLATE,PCB EARTH PLATE,EARTH PLATE,EARTH BRACKET,PCB		CMC1A111 CMC1A272 HJT1A025 HJT1A025 CMD1A387		
 	F401 F401 FL21		00D 943 0184 704 00D 943 0108 308 00D 943 0181 503	FUSE FUSE F.I.P HCA13SS21	E2 EUT	KBA2C0315TLEY KBA2C0630TLEY CFLHCA13SS21		
	HF41 HF42 JK71		- - 00D 943 0183 103	HOLDER , FUSE HOLDER , FUSE OPTICAL(TX) TOTX177L		KJCFC5S KJCFC5S HJSTOTX177L		
	JK72 JW01 L201		00D 943 0186 304 - -	JACK L,R (2P SILVER) RING WIRE WIRE COPPER		CJJ4N062Z CWE8202100SP C3A206		*
	L301,302 L401 L402 L501 L751		- 00D 943 0183 200 - 00D 943 0183 200 -	WIRE COPPER COIL WIRE COPPER COIL WIRE COPPER		C3A206 HLQ02C100KT C3A206 HLQ02C100KT C3A206		
	PH31 RC21		00D 943 0181 600 00D 943 0183 501	JACK H/P SENSOR KSM-603TH2A		CJJ2E020Z HRVKSM603TH2A		
  	S201-207 SW41 T401 T401		00D 943 0077 206 00D 943 0184 801 00D 943 0182 308 00D 943 0182 405	SW , TACT SW ,CSH1A010ZV(SDL1P-B) TRANS , POWER(EUR) TRANS , POWER (TC)	E2 EUT	CST1A012ZT CSH1A010ZV CLT5M031ZES CLT5M031ZUS		
	VR31 X501 X502		00D 943 0183 006 00D 943 0183 404 00D 943 0183 307	RES , VR(B CURVE) CRYSTAL CRYSTAL 8MHz		CVV2J02B103Z HOX16934A120C HOX08000E160C		
			- - -	PLATE , HEAT SINK HEATSINK SCREW		CMY1A276 CMY4A222 CTB3+8JR		

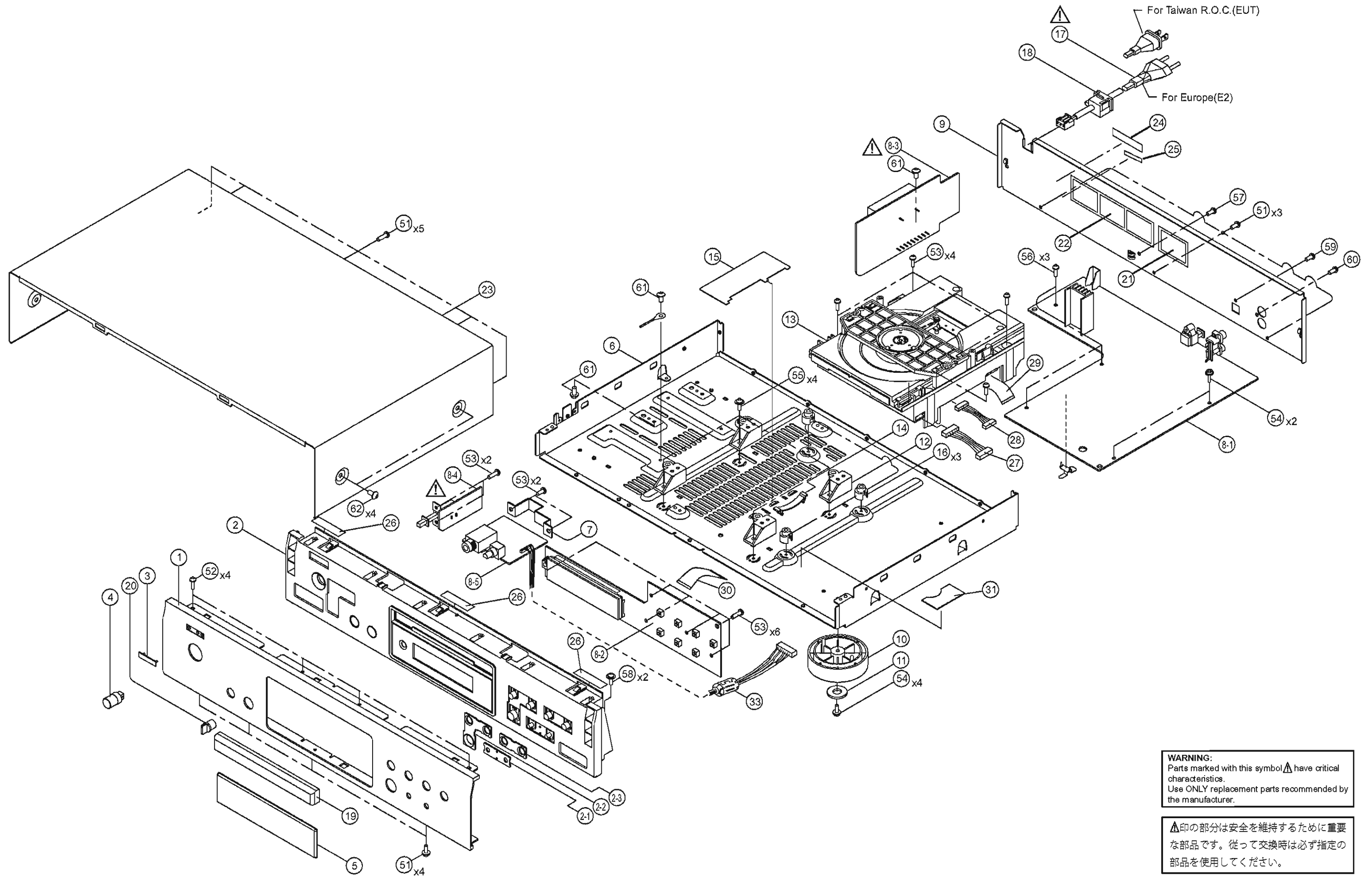

**WARNING:**  
 Parts marked with this symbol  have critical characteristics.  
 Use ONLY replacement parts recommended by the manufacturer.

印の部分は安全を維持するために重要な部品です。従って交換時は必ず指定の部品を使用してください。

## PARTS LIST OF EXPLODED VIEW

\* 本表に記載されている部品は、補修用部品のため製品に使用している部品とは一部、形状、寸法などが異なる場合があります。

\* The parts listed below are for maintenance only, might differ from the parts used in the unit in appearances or dimensions.

\* "nsp" 印の部品は常時在庫していませんので供給に長時間を要することがあります。場合によっては、供給をお断りする場合があります。

\* Part indicated with the mark "nsp" are not always in stock and possibly to take a long period of time for supplying, or in some case supplying of part may be refused.

Note: The symbols in the column "Remarks" indicate the following destinations.

BKE2 : Europe model(Black)

SPE2 : Europe model(Premium Silver)

EUT : Taiwan R.O.C. model(Premium Silver)

Ref. No.	nsp	Part No.	Part Name	Remark		Q'ty	New	
8		-	MAIN P.W.B. ASSY (DCD500AE)	BKE2,SPE2	COP11902B	1	*	
		-	MAIN P.W.B. ASSY (DCD500AE)	EUT	COP11902C	1	*	
	8-1		MAIN UNIT					
	8-2		FRONT UNIT					
	8-3		POWER UNIT					
8-4			POWER SW UNIT					
	8-5		H/P UNIT					
	1		00D 943 0178 707	PANEL , FRONT	BKE2	CKM1A180ZC45	1	*
	1		00D 943 0178 804	PANEL , FRONT	SPE2,EUT	CKM1A180YC62	1	*
	2	nsp	00D 943 0178 901	PANEL , INNER	BKE2	CGW1A424B2	1	*
2	nsp	00D 943 0179 007	PANEL , INNER	SPE2,EUT	CGW1A424RGG45	1	*	
	2-1	-	GUIDE,KNOB		CGW1A424-1	1		
2-2		-	GUIDE,KNOB		CGW1A424-2	1		
	2-3	-	GUIDE,KNOB		CGW1A424-3	1		
3	nsp	00D 131 0158 007	BADGE	BKE2	CGB1A171Z	1		
3	nsp	00D 131 0158 010	BADGE	SPE2,EUT	CGB1A171Y	1		
4		00D 943 0179 502	KNOB , POWER	BKE2	CGK1A124ZA	1	*	
4	nsp	00D 943 0179 609	KNOB , POWER	SPE2,EUT	CGK1A124YA	1	*	
5	nsp	00D 943 0179 706	WINDOW , FIP		CGU1A397Z	1	*	
6		-	CHASSIS , BOTTOM		CUA1A269	1	*	
7		-	BRACKET , PHONE		CMD1A598	1	*	
9	nsp	00D 943 0179 308	PANEL , REAR	BKE2,SPE2	CKF1A316Z	1	*	
9	nsp	00D 943 0179 405	PANEL , REAR	EUT	CKF1A316Y	1	*	
10	nsp	00D 104 0334 007	FOOT		CKL1A093	4		
11	nsp	00D 943 0179 900	CUSHION , FOOT		CHG2A289	4		
12	nsp	00D 943 0180 009	SUPPORT , MECHA		CMH1A259	4	*	
13		00D 943 0180 106	CD MECHANISM ASSY		CJDKSL2130CCMZ	1		
⚠	14	nsp	00D 943 0180 203	CLAMP , FLAT CABLE		CMH1A261	1	
	15	nsp	00D 943 0180 300	INSULATOR		CMX1A185	1	*
	16		-	HOLDER , P.W.B.		CHE170	3	
	17		00D 943 0180 407	CORD , POWER(EUR)	BKE2,SPE2	CJA2B043ZA	1	
	17		00D 943 0180 504	POWER, CORD	EUT	CJA2L072ZA	1	*
18		00D 943 0180 601	BUSHING , AC CORD		KHR1A028	1		
19		00D 943 0180 708	DOOR	BKE2	CGR1A404ZB2	1	*	
19		00D 943 0180 805	DOOR	SPE2,EUT	CGR1A404RGYG45	1	*	
20		00D 943 0180 902	KNOB , LEVEL	BKE2	CBC1A157B2	1	*	
20		00D 943 0181 008	KNOB , LEVEL	SPE2,EUT	CBC1A157RGG45	1	*	
21		-	LABEL , LASER	BKE2,SPE2	CQB1A682Z	1		
22		-	E2 LASER LABEL	BKE2,SPE2	CQB1A689Z	1		
23	nsp	00D 943 0181 105	COVER , TOP	BKE2	CKC1A175S56	1	*	
23	nsp	00D 943 0181 202	COVER , TOP	SPE2,EUT	CKC1A175S55	1	*	
24		-	LABEL , SERIAL NO	BKE2,SPE2	CQB1A622	1		
24		-	LABEL , SERIAL NO	EUT	CQB1A776	1	*	
25		-	LABEL , CHINA	EUT	CQB1A774Z	1	*	
26	nsp	00D 943 0186 401	HEMELON TAPE		CHS1A032	3	*	



	Ref. No.	nsp	Part No.	Part Name	Remark		Q'ty	New
	27		00D 943 0186 508	WIRE ASS'Y		CWB1B005080EG	1	*
	28		00D 943 0186 605	WIRE ASS'Y		CWB5A906080EG	1	*
	29		00D 943 0186 702	CARD CABLE		CWC4F1A16A220B	1	*
	30		00D 943 0186 809	CARD CABLE		CWC4F4A11A100A	1	*
	31		00D 943 0200 904	HT INSULATOR		CMX1A187	1	*
	33		00D 943 0201 000	FERRITE CORE		CLZ9Z071Z	1	*
<b>SCREWS</b>								
	51		-	SCREW 3x8	BKE2	CTBD3+8JFZR	12	
	51		-	SCREW 3x8	SPE2,EUT	CTBD3+8JFN	9	
	52		-	SCREW 3x8	BKE2	CTB3+8GFZR	4	
	52		-	SCREW 3x8	SPE2,EUT	CTB3+8GFN	4	
	53		-	SCREW 3x10		CTB3+10GR	14	
	54		-	SCREW 3x8		CTW3+8JR	6	
	55		-	SCREW 3x6		CTW3+6JR	4	
	56		-	SCREW 3x12		CTW3+12JR	3	
	57		-	SCREW 3x6		CTB3+6FFZR	1	
	58		-	SCREW 3x8		CTB3+8JR	2	
	59		-	SCREW 3x8		CTB3+8GFZR	1	
	60		-	SCREW 3x10		CTB3+10GFZR	1	
	61		-	SCREW , TRANS		CTB4+6FR	3	
	62		-	SCREW 4x6	BKE2	CTB4+6JFZR	4	
	62		-	SCREW 4x6	SPE2,EUT	CTB4+6JFN	4	

# EXPLODED VIEW OF CD MECHANISM UNIT (KSL 2130 CCM)

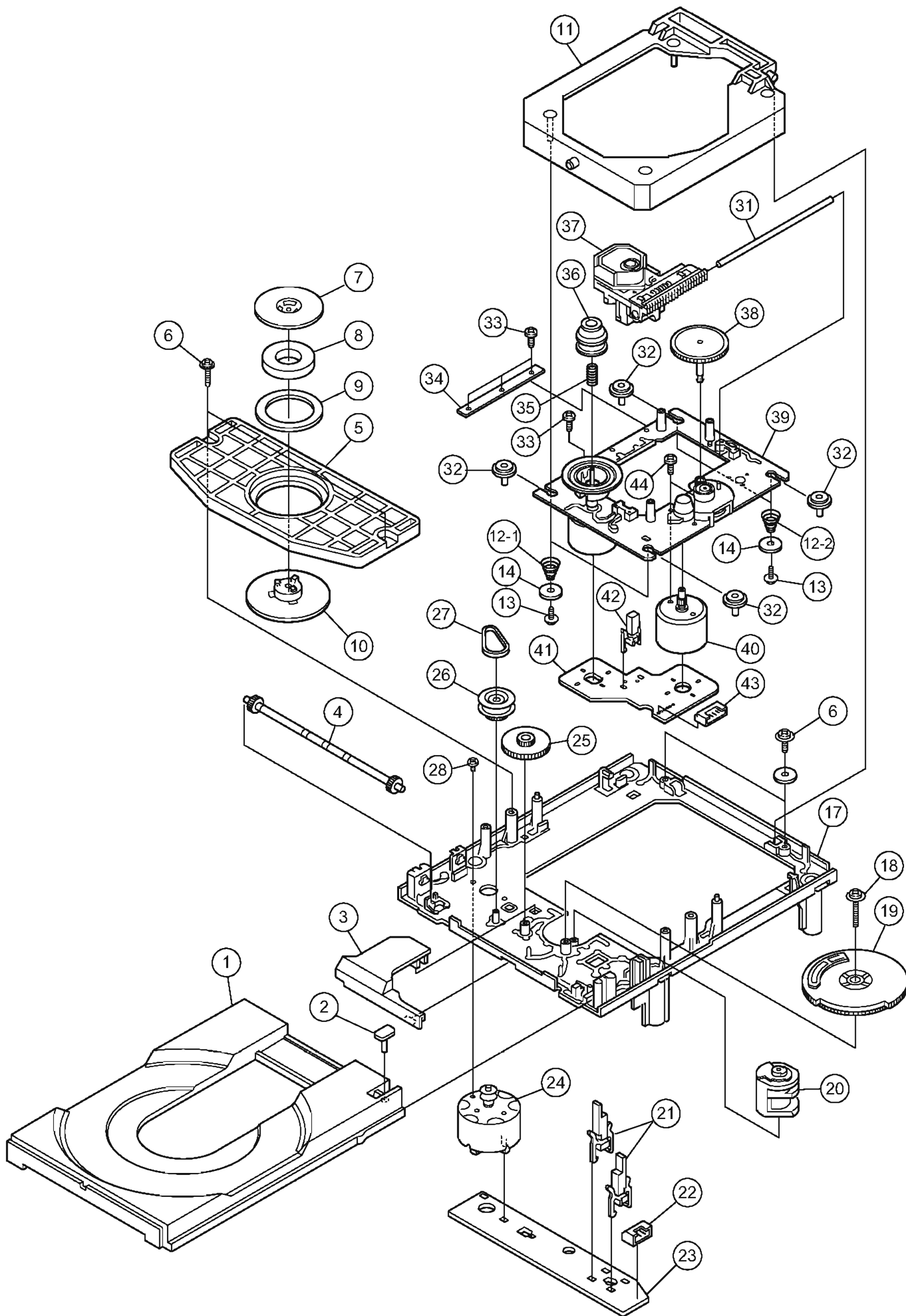

## PARTS LIST OF CD MECHANISM UNIT

\*本表に記載されている部品は、補修用部品のため製品に使用している部品とは一部、形状、寸法などが異なる場合があります。

\* The parts listed below are for maintenance only, might differ from the parts used in the unit in appearances or dimensions.

\* "nsp" 印の部品は常時在庫していませんので供給に長時間を要することがあります。場合によっては、供給をお断りする場合があります。

\* Part indicated with the mark "nsp" are not always in stock and possibly to take a long period of time for supplying, or in some case supplying of part may be refused.

Ref. No.	nsp	Part No.	Part Name	Remarks	Q'ty	New
1		00D S26 4629 001	Tray (C)		1	
2		-	-	This part (No.2) doesn't belong to the tray. Take it down from old tray and use again when changing the tray.		
3		00D S26 2554 401	Gear cover(S)		1	
4		00D S26 2553 501	Tray gear(S)		1	
5		00D S26 2554 601	Chucking plate		1	
6	nsp	00D S26 2629 401	Screw 2.6 x 7 +PTPWH		4	
7	nsp	00D S26 2553 701	Chucking yoke		1	
8	nsp	00D S14 5249 321	Magnet		1	
9	nsp	00D S26 2554 102	Damper		1	
10	nsp	00D S26 4629 101	Chucking pulley		1	
11	nsp	00D S26 4628 801	Sub chassis Ass'y		1	
12-1		00D S26 2723 601	Coil spring(front)		2	
12-2		00D S26 2723 501	Coil spring(back)		2	
13		-	Screw 2.6 x 10 +P	No slit type2	4	
14	nsp	00D S26 4628 901	Washer 2130		4	
17	nsp	00D S26 2555 206	Outsert main chassis(S)		1	
18	nsp	00D S33 1950 151	Screw 2.6 x 16 +PTPWH		1	
19		00D S26 2554 701	Drive gear(S)		1	
20		00D S26 2554 504	Contorol cam(S)		1	
21		00D S16 9266 711	Leaf switch		2	
22	nsp	00D S15 6472 111	5P connector		1	
23	nsp	00D S16 4052 311	Loading P.W.B		1	
24		00D SX2 6251 171	Loading motor Ass'Y		1	
25		00D S26 2553 402	Middle gear		1	
26		00D S26 2553 602	Loading pulley		1	
27		00D S36 5338 700	LM belt		1	
28	nsp	00D S26 2527 901	Screw 2.6 x 2.5 +B		1	
31		00D S26 2690 801	Sled shaft		1	
32		00D S26 2723 401	Insulator		4	
33	nsp	00D S26 4138 601	Tapping screw 2 x 5		4	
34	nsp	00D S26 2562 501	Plate		1	
35		00D S26 2519 101	Coil spring		1	
36		00D S26 2547 701	Center ring		1	
37		00D S88 4848 305	Laser pick up	KSS-213C	1	
38		00D S26 2518 802	Gear(A)		1	
39		00D SX2 6259 841	Motor chassis Ass'y		1	
40		00D SX2 6257 691	Motor gear Ass'y		1	
41	nsp	00D S16 3967 812	Motor P.W.B.		1	
42		00D S15 7208 511	Leaf switch		1	
43	nsp	00D S15 6472 211	6P connector		1	
44	nsp	00D S76 2125 515	Screw 2 x 3 +P		1	

## PACKING VIEW

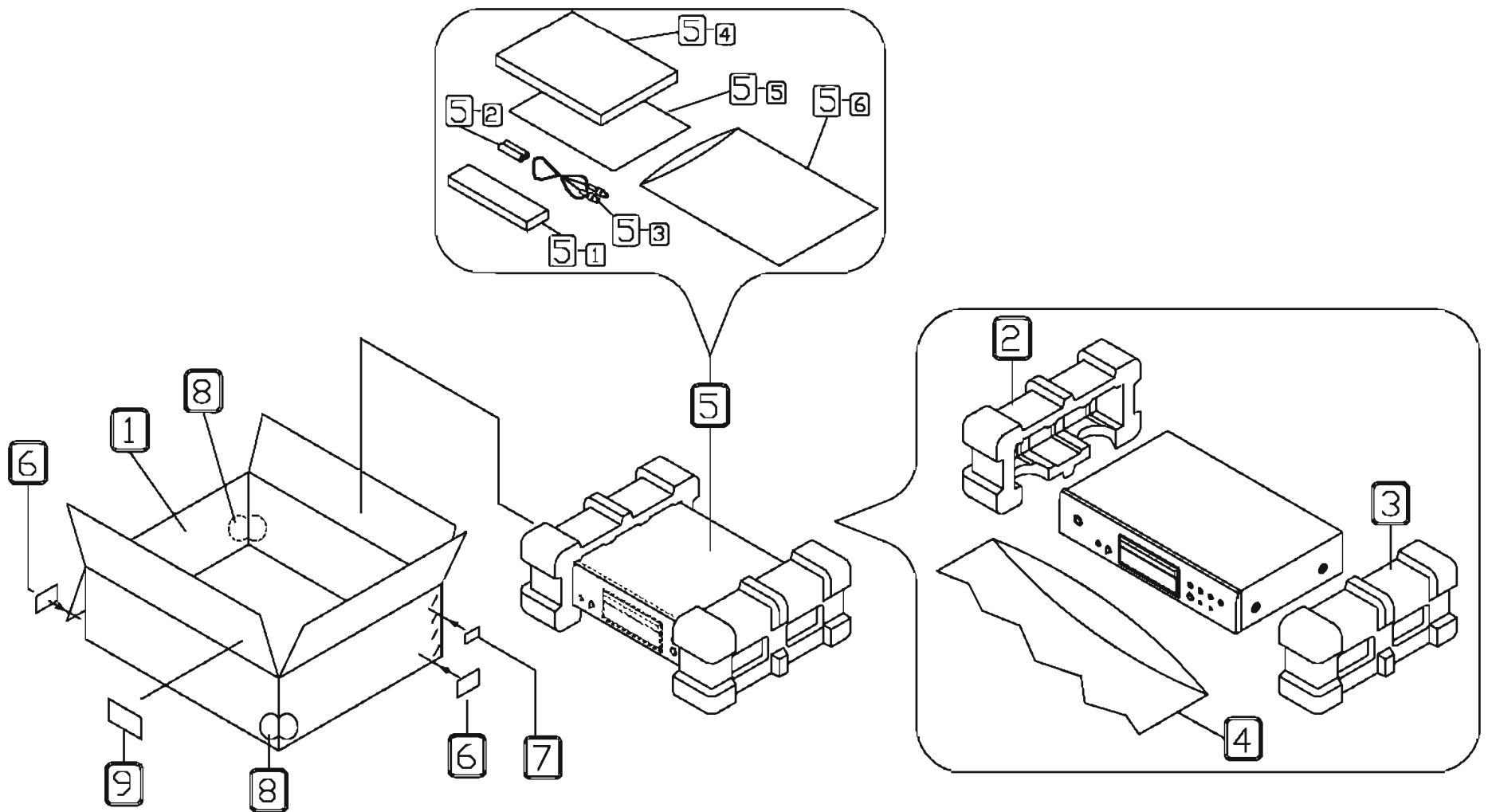

## PARTS LIST OF PACKING &amp; ACCESSORIES

\* 本表に記載されている部品は、補修用部品のため製品に使用している部品とは一部、形状、寸法などが異なる場合があります。

\* The parts listed below are for maintenance only, might differ from the parts used in the unit in appearances or dimensions.

\* "nsp" 印の部品は常時在庫していませんので供給に長時間を要することがあります。場合によっては、供給をお断りする場合があります。

\* Part indicated with the mark "nsp" are not always in stock and possibly to take a long period of time for supplying, or in some case supplying of part may be refused.

**Note:** The symbols in the column "Remarks" indicate the following destinations.

BKE2 : Europe model(Black)

SPE2 : Europe model(Premium Silver)

SPEUT : Taiwan R.O.C. model(Premium Silver)

Ref. No.	nsp	Part No.	Part Name	Remark		Q'ty	New
1	nsp	00D 943 0178 105	BOX , OUT CARTON		CPG1A819Z	1	*
2	nsp	00D 943 0177 902	PAD , SNOW		CPS1A748	1	*
3	nsp	00D 943 0178 008	PAD , SNOW		CPS1A749	1	*
4		-	BAG , POLY		CPB1A013Y	1	
5		-	INSTRUCTION MANUAL ASSY			1	
5-1		00D 399 1052 012	REMOCON RC-1028 BK	BKE2	CARTDCD500AEBK	1	*
5-1		00D 399 1052 009	REMOCON RC-1028 SP	SPE2,EUT	CARTDCD500AESP	1	*
5-2		-	BATTERY (SIZE 'AAA')		CABR03P	1	
5-3		00D 943 0178 406	CORD, PIN		CJS4N014Z	1	
5-4		00D 943 0178 503	MANUAL , INSTRUCTION	BKE2,SPE2	CQX1A1148Z	1	*
5-4		00D 943 0178 600	MANUAL , INSTRUCTION	EUT	CQX1A1149Z	1	*
5-5	nsp	00D 515 0921 704	LIST , S.S (EX)		CQE1A226V	1	
5-6		-	BAG , POLY		CPB1061Y	1	
6		-	LABEL , CONTROL	BKE2	CQB1A627	2	*
6		-	LABEL , CONTROL	SPE2		2	*
6		-	LABEL , CONTROL	EUT		2	*
7		-	LABEL , POS	BKE2	CQB1A772Z	2	*
7		-	LABEL , POS	SPE2	CQB1A772Y	2	*
8		-	LABEL , COLOR	SPE2,EUT	CQB1A676Y	2	
9		-	LABEL , CARTON	EUT	CQB1A775Z	1	*

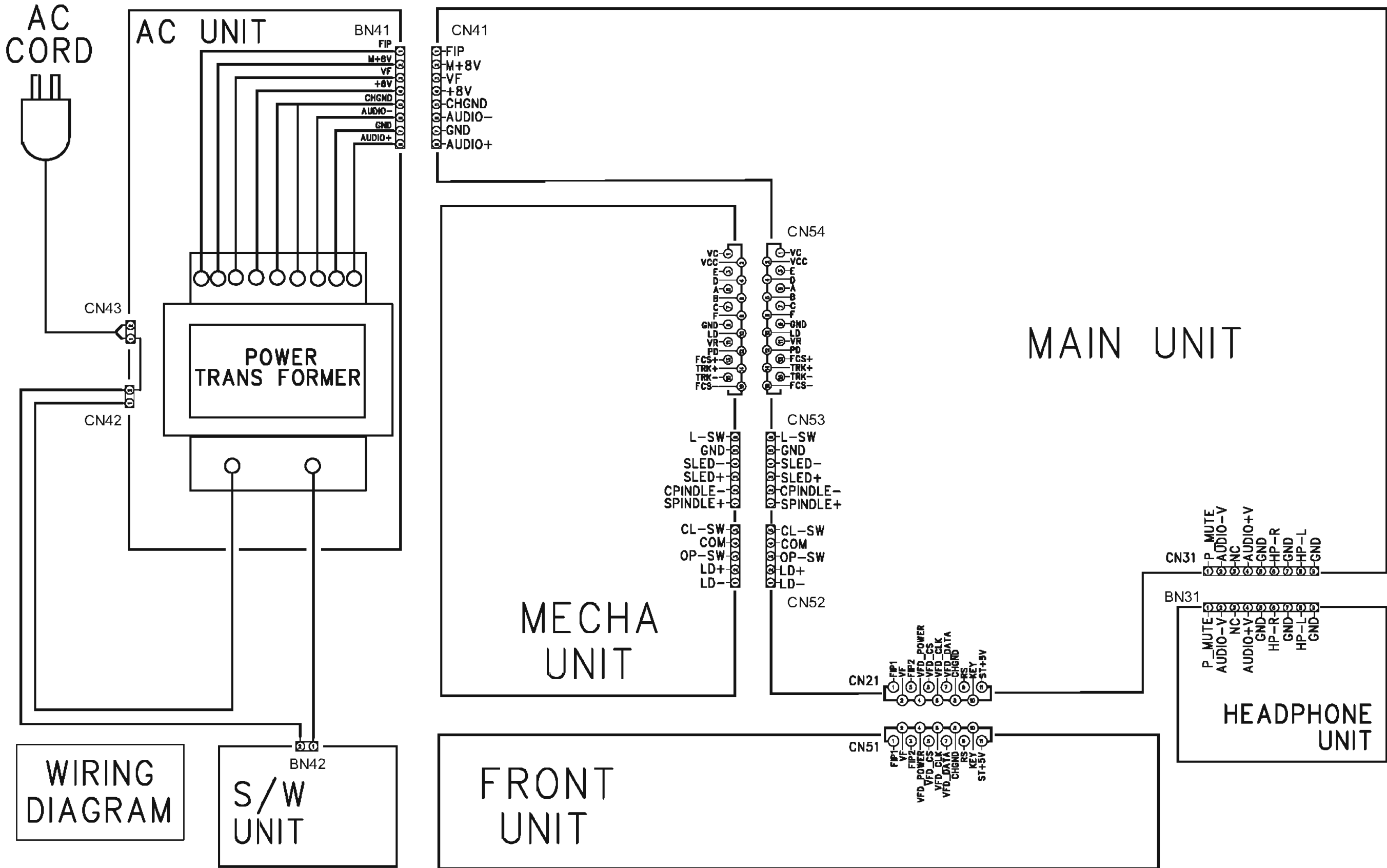

WIRING DIAGRAM

S/W UNIT

FRONT UNIT

MECHA UNIT

MAIN UNIT

HEADPHONE UNIT

## NOTE FOR SCHEMATIC DIAGRAM

### WARNING:

Parts marked with this symbol  $\triangle$  have critical characteristics. Use ONLY replacement parts recommended by the manufacturer.

### CAUTION:

Before returning the unit to the customer, make sure you make either (1) a leakage current check or (2) a line to chassis resistance check. If the leakage current exceeds 0.5 milliamps, or if the resistance from chassis to either side of the power cord is less than 460 kohms, the unit is defective.

### WARNING:

DO NOT return the unit to the customer until the problem is located and corrected.

### NOTICE:

ALL RESISTANCE VALUES IN OHM. k=1,000 OHM  
M=1,000,000 OHM  
ALL CAPACITANCE VALUES IN MICRO FARAD.  
P=MICRO-MICRO FARAD  
EACH VOLTAGE AND CURRENT ARE MEASURED AT  
NO SIGNAL INPUT CONDITION.  
CIRCUIT AND PARTS ARE SUBJECT TO CHANGE  
WITHOUT PRIOR NOTICE.

## 配線図について

$\triangle$ 印の部品は安全を維持するために重要な部品です。従って交換時は必ず指定の部品を使用してください。

### 注)

- (1) 指定なき抵抗値は  $\Omega$ 、k は  $k\Omega$ 、M は  $M\Omega$  を示す。
- (2) 指定なきコンデンサーの値は  $\mu F$ 、p は  $pF$  を示す。
- (3) 各部の電圧は無信号の値を示す。
- (4) この配線図は基本配線図です。改良等のため変更することがありますのでご了承ください。

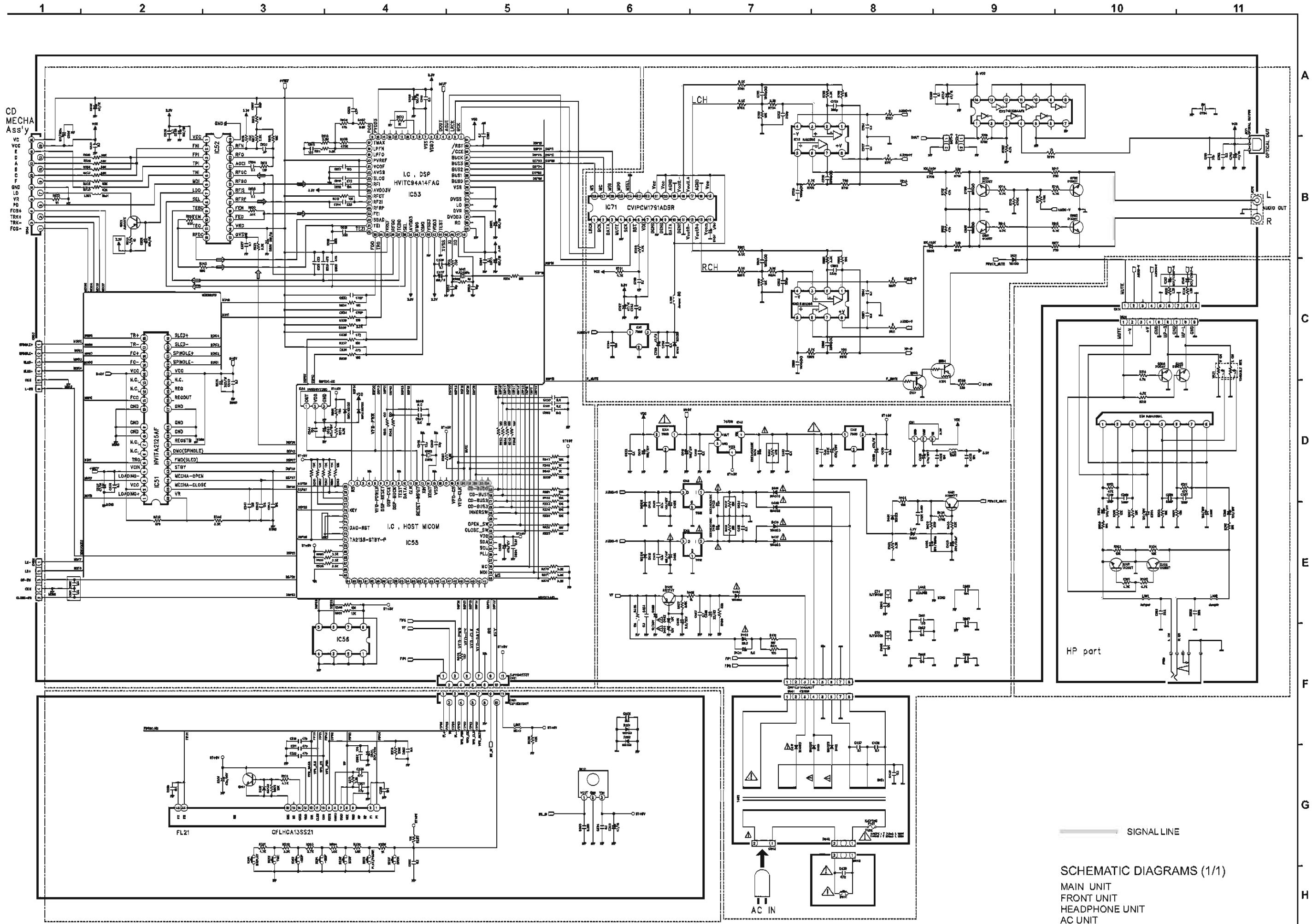

## DOCUMENTS FOR WEEE

## Details of Recycle parts for Main Unit

\* You have to remove the parts that marked "WEEE Mark ◆" when the recycling processing. (Europe model only)

Ref. NO.	WEEE Mark	Part Name	Material	Q'ty
1		PANEL , AL	AL	1
2		PANEL , INNER	ABS	1
2-1		GUIDE,KNOB	ABS	1
2-2		GUIDE,KNOB	ABS	1
2-3		GUIDE,KNOB	ABS	1
3		BADGE	AL	1
4	◆	KNOB , POWER	COMPLEX	1
5		WINDOW , FIP	PMMA	1
6		CHASSIS , BOTTOM	STEEL.	1
7		BRACKET , PHONE	STEEL.	1
8-1	◆	MAIN P.W.B. ASSY	COMPLEX	1
8-2	◆	FRONT P.W.B. ASSY	COMPLEX	1
8-3	◆	POWER TRANS P.W.B. ASSY	COMPLEX	1
8-4	◆	POWER SW P.W.B. ASSY	COMPLEX	1
8-5	◆	H/P P.W.B. ASSY	COMPLEX	1
9		PANEL , REAR	STEEL.	1
10		FOOT	ABS	4
11		CUSHION , FOOT	PORON	4
12		SUPPORT , MECHA	ABS	4
13	◆	CD MECHANISM ASSY	COMPLEX	1
14		CLAMP , FLAT CABLE	PA66	1
15		INSULATOR	PC	1
16		HOLDER , P.W.B.	ABS	3
17	◆	CORD , POWER	COMPLEX	1
18		BUSHING , AC CORD	PA66	1
19		DOOR	ABS	1
20		KNOB , LEVEL	ABS	1
21		LABEL , LASER	PE	1
22		E2 LASER LABEL	PE	1
23		COVER , TOP	STEEL+PVC	1
24		LABEL , SERIAL NO	PAPER	1
26		HEMELON TAPE	PE	3
27	◆	WIRE ASS'Y	COMPLEX	1
28	◆	WIRE ASS'Y	COMPLEX	1
29	◆	CARD CABLE	COMPLEX	1
30	◆	CARD CABLE	COMPLEX	1
31		HT INSULATOR	PC	1
32		TRANS , POWER	COMPLEX	1
33	◆	FERRITE CORE	COMPLEX	1
51		SCREW	STEEL.	12
52		SCREW	STEEL.	4
53		SCREW	STEEL.	14
54		SCREW	STEEL.	6
55		SCREW	STEEL.	4
56		SCREW	STEEL.	3
57		SCREW	STEEL.	1
58		SCREW	STEEL.	2
59		SCREW	STEEL.	1
60		SCREW	STEEL.	1
61		SCREW , TRANS	STEEL.	3
62		SCREW	STEEL.	4



## Exploded view of DCD-500AE Main unit (Europe model)

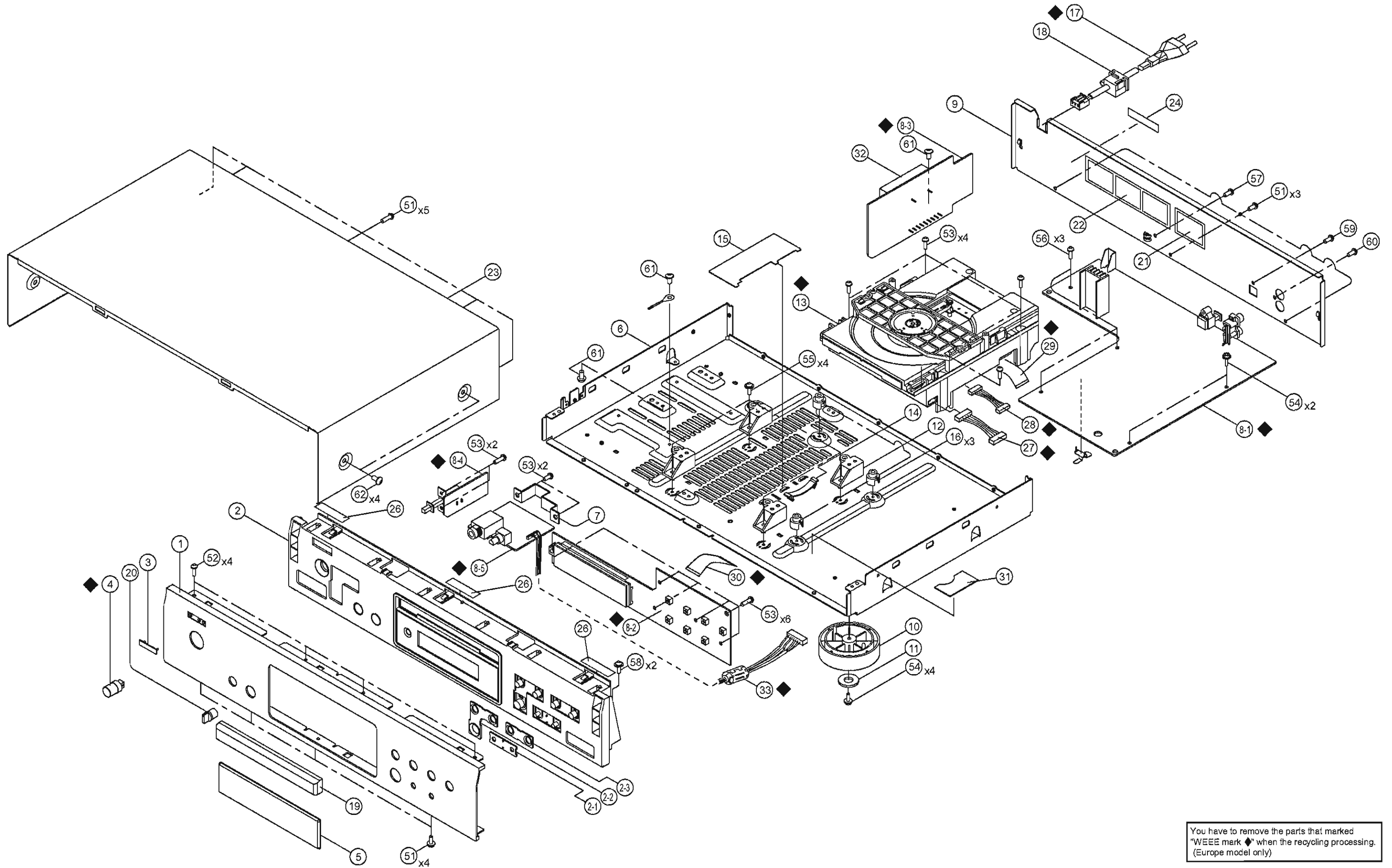

You have to remove the parts that marked "WEEE mark" when the recycling processing. (Europe model only)

Details of Recycle parts for Power transformer (Ref. No.32)

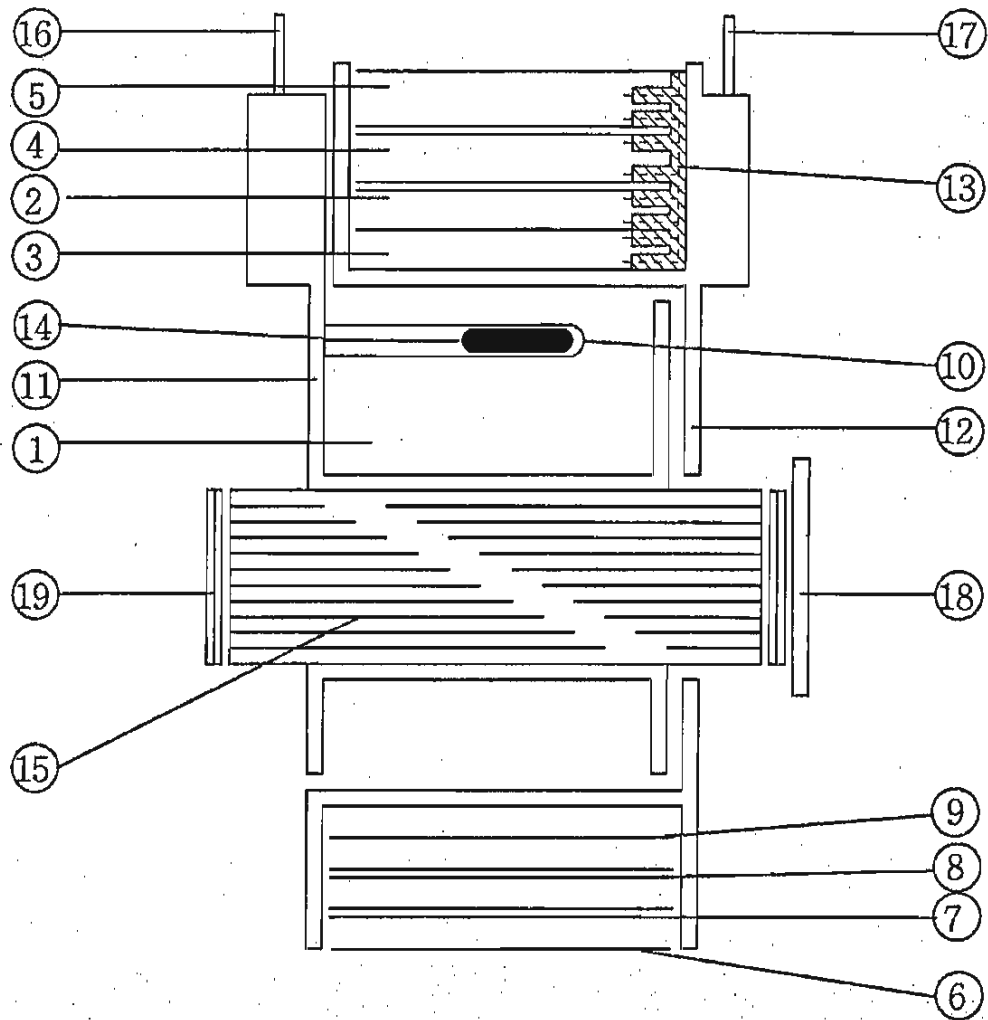

Ref. No.	Material
1	COPPER
2	COPPER
3	COPPER
4	COPPER
5	COPPER
6	PET
7	PET
8	PET
9	PET
10	PET
11	PETP
12	PETP
13	PET
14	COMPLEX
15	STEEL
16	COPPER
17	COPPER
18	STEEL
19	STEEL