



V20989

# DENON

Hi-Fi Component

## SERVICE MANUAL

# MODEL DCD-735 MODEL DCD-635

## STEREO CD PLAYER

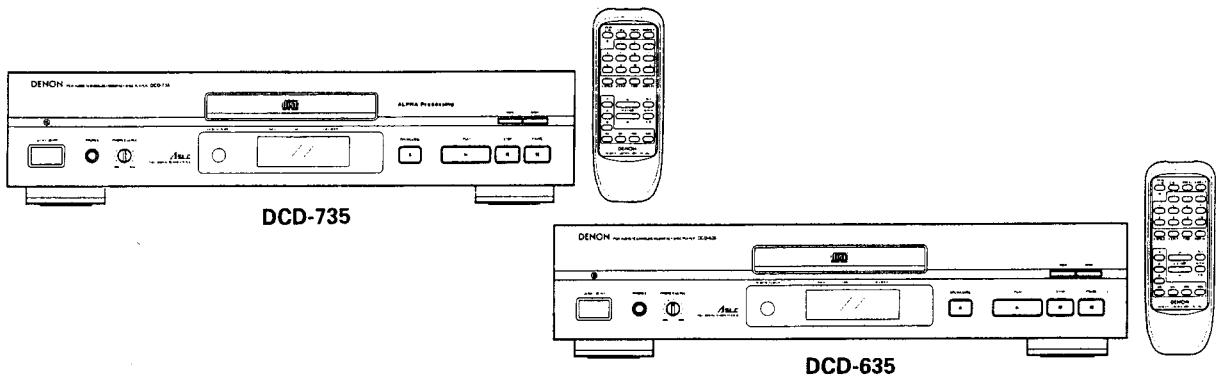

### — CONTENTS —

OPERATING INSTRUCTIONS .....	2-7
DISASSEMBLY .....	8, 9
CONFIRMING METHOD OF SERVO .....	10-12
TEST METHOD FOR HEAT RUN MODE .....	13
NOTE FOR HANDLING OF THE LASER PICK-UP .....	13-17
SEMICONDUCTORS .....	18-22
NOTE FOR PARTS LIST .....	23
PARTS LIST OF PRINTED WIRING BOARD .....	24, 25
PRINTED WIRING BOARD .....	26, 27
EXPLODED VIEW OF CHASSIS AND CABINET .....	28
PARTS LIST OF EXPLODED VIEW .....	29
EXPLODED VIEW OF CD MECHANISM UNIT .....	30
PARTS LIST OF CD MECHANISM UNIT .....	30
EXPLODED VIEW OF OPTICAL PICK-UP UNIT .....	30
PARTS LIST OF OPTICAL PICK-UP UNIT .....	30
WIRING DIAGRAM .....	31
SCHEMATIC DIAGRAM .....	32-34

• Some illustration using in this service manual is slightly different from the actual set.

# NIPPON COLUMBIA CO., LTD.

**NOTE ON USE/HINWEISE ZUM GEBRAUCH/OBSERVATIONS RELATIVES A L'UTILISATION  
NOTE SULL'USO/NOTAS SOBRE EL USO/ALVORENS TE GEBRUIKEN/OBSERVERA  
OBSERVAÇÕES QUANTO AO USO**

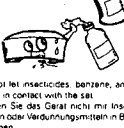
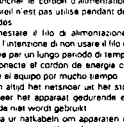
 <ul style="list-style-type: none"> <li>• Avoid high temperatures. Allow for sufficient heat dispersion when installed on a rack.</li> <li>• Vermeiden Sie hohe Temperaturen. Rechnen Sie auf eine ausreichende Luftzirkulation gewährt/wird, wenn das Gerät auf einen Regal gestellt wird.</li> <li>• Evitez des températures élevées. Tenez compte d'une dispersion de chaleur suffisante lors de l'installation sur une étagère.</li> <li>• Evitare di esporre l'unità a temperature alte. Assicurarsi che ci sia un'adeguata dispersione del calore quando si installa l'unità in un mo- do per componenti audio.</li> <li>• Evite altas temperaturas. Permita la suficiente dispersión del calor cuando sea instalado en la consola.</li> <li>• Vermijd hoge temperaturen. Zorg voor een degelijke hitteafvoer indien het apparaat op een rack wordt geplaatst.</li> <li>• Unhvik høge temperaturer. Se i alle del tilsynsmødt til god varmeaf- føring ved montering af et rack.</li> <li>• Evite temperaturas altas. Conceda suficiente dispersão de calor quando o equipamento for instalado numa prateleira.</li> </ul>	 <ul style="list-style-type: none"> <li>• Keep the set free from moisture, water, and dust.</li> <li>• Halten Sie das Gerät von Feuchtigkeit, Wasser und Staub fern.</li> <li>• Protégez l'appareil contre l'humidité, l'eau et la poussière.</li> <li>• Tenete l'unità lontana dall'umidità, dall'acqua e dalla polvere.</li> <li>• Mantenga el equipo libre de humedad, agua y polvo.</li> <li>• Laat geen vochtigheid/water of stof in het apparaat binnendringen.</li> <li>• Låt inte apparaten fukt, vatten och damm.</li> <li>• Mantenha o aparelho livre de qualquer umidade de água ou poeira.</li> </ul>	 <ul style="list-style-type: none"> <li>• Do not let foreign objects in the set.</li> <li>• Keine fremden Gegenstände in das Gerät kommen lassen.</li> <li>• Ne pas laisser des objets étrangers dans l'appareil.</li> <li>• È importante che nessun oggetto è inserito all'interno dell'unità.</li> <li>• No debe colocar artículos dentro del equipo.</li> <li>• Laat geen vreemde voorwerpen in het apparaat vallen.</li> <li>• Se ill alt frammede foremler i ut apparaten.</li> <li>• Não deve objetos estranhos no aparelho.</li> </ul>
 <ul style="list-style-type: none"> <li>• Handle the power cord carefully. Hold the plug when unplugging the cord.</li> <li>• Gehen Sie vorsichtig mit dem Netzabzahn um. Halten Sie das Kabel am Stecker, wenn Sie den Stecker herausziehen.</li> <li>• Manipuler le cordon d'alimentation avec précaution. Tenez la prise lors du débranchement du cordon.</li> <li>• Maneggiare il filo di alimentazione con cura. Agire per la spina quando scollegate il cavo dal la presa.</li> <li>• Manipule el cordon de energia con cuidado. Sostenga el enchufe cuando desconecte el cordon de energia.</li> <li>• Hanteera het netkabel voorzichtig. Hou het snoer bij de steekker vast wanneer de za moet worden aan- of losgeplaatst.</li> <li>• Mantere nätkabeln varsamt. Hall i samband när den kopplas från uttaget.</li> <li>• Manipulase com cuidado o fio condutor de energia. Segure a tomada ao desconectar o fio.</li> </ul>	 <ul style="list-style-type: none"> <li>• Unplug the power cord when not using the set for long periods of time.</li> <li>• Wenn das Gerät eine längere Zeit nicht verwendet werden soll, trennen Sie das Netzabzahn vom Netzstecker.</li> <li>• Débranchez le cordon d'alimentation lorsque l'appareil n'est pas utilisé pendant de longues périodes.</li> <li>• Disinnestare il filo di alimentazione quando avete l'intenzione di non usare il filo di alimentazione per un lungo periodo di tempo.</li> <li>• Desconecte el cordon de energia cuando no utilize el equipo por mucho tiempo.</li> <li>• Neem altijd het netkabel uit het stopcontact wanneer het apparaat gedurende een lange periode niet wordt gebruikt.</li> <li>• Kopota ur nätkabeln om apparaten inte kommer att användas i lång tid.</li> <li>• Desligue o fio condutor de força quando o aparelho não tiver que ser usado por um longo período.</li> </ul>	 <ul style="list-style-type: none"> <li>• Do not let insecticides, benzene, and thinner come in contact with the set.</li> <li>• Lassen Sie das Gerät nicht mit Insektiziden, Benzin oder Verdünnungsmitteln in Berührung kommen.</li> <li>• Ne pas mettre en contact des insecticides, du benzène et un diluant avec l'appareil.</li> <li>• Assicurarsi che l'unità non venga in contatto con insetticidi, benzolo o solventi.</li> <li>• No permita el contacto de insecticidas, gasolina y diluyentes con el equipo.</li> <li>• Laat geen insectenverdelgende middelen, benzine of verdunningsmiddel met het apparaat in contact komen.</li> <li>• Se ill alt insektismiddel på spraybøl, bensin och thinner kommer i kontakt med apparatens hölje.</li> <li>• Não permita que inseticidas, benzina e dissolvente entrem em contacto com o aparelho.</li> </ul>
 <ul style="list-style-type: none"> <li>• Handle the power cord carefully. Hold the plug when unplugging the cord.</li> <li>• Gehen Sie vorsichtig mit dem Netzabzahn um. Halten Sie das Kabel am Stecker, wenn Sie den Stecker herausziehen.</li> <li>• Manipuler le cordon d'alimentation avec précaution. Tenez la prise lors du débranchement du cordon.</li> <li>• Maneggiare il filo di alimentazione con cura. Agire per la spina quando scollegate il cavo dal la presa.</li> <li>• Manipule el cordon de energia con cuidado. Sostenga el enchufe cuando desconecte el cordon de energia.</li> <li>• Hanteera het netkabel voorzichtig. Hou het snoer bij de steekker vast wanneer de za moet worden aan- of losgeplaatst.</li> <li>• Mantere nätkabeln varsamt. Hall i samband när den kopplas från uttaget.</li> <li>• Manipulase com cuidado o fio condutor de energia. Segure a tomada ao desconectar o fio.</li> </ul>	 <ul style="list-style-type: none"> <li>• Do not obstruct the ventilation holes.</li> <li>• Die Belüftungslöcher dürfen nicht verdeckt werden.</li> <li>• Ne pas obstruer les trous d'aération.</li> <li>• Non coprire i fori di ventilazione.</li> <li>• No obstruya los orificios de ventilación.</li> <li>• De ventilationsopeningen mogen niet worden bedekt/leed.</li> <li>• Täpa inte till ventilationsöppningarna.</li> <li>• Não obstrua os orificios de ventilação.</li> </ul>	 <ul style="list-style-type: none"> <li>• Never disassemble or modify the set in any way.</li> <li>• Versuchen Sie niemals das Gerät auseinander zu nehmen oder auf irgendige Art zu verändern.</li> <li>• Ne jamais démonter ou modifier l'appareil d'une manière ou d'une autre.</li> <li>• Non smontare mai né modificare l'unità in nessun modo.</li> <li>• Nunca desarme o modifique el equipo de ninguna manera.</li> <li>• Não desmonte nem modifique o aparelho de alguma forma.</li> </ul>

**IMPORTANT TO SAFETY**  
**WARNING:**  
**TO PREVENT FIRE OR SHOCK HAZARD, DO NOT EXPOSE THIS APPLIANCE TO RAIN OR MOISTURE.**

**NOTE:**  
This CD player uses the semiconductor laser. To allow you to enjoy music at a stable operation, it is recommended to use this in a room of 5°C (41°F) - 35°C (95°F).



**DECLARATION OF CONFORMITY**  
We declare under our sole responsibility that this product, to which this declaration relates, is in conformity with the following standards: EN60065, EN55013, EN55020, EN60555-2 and EN60555-3  
Following the provisions of 73/23/EEC, 89/336/EEC and 93/68/EEC Directive.

**ÜBEREINSTIMMUNGSERKLÄRUNG**  
Wir erklären unter unserer Verantwortung, dass dieses Produkt, auf das sich diese Erklärung bezieht, den folgenden Standards entspricht: EN60065, EN55013, EN55020, EN60555-2 und EN60555-3  
Entsprechend den Bestimmungen der Direktive 73/23/EEC, 89/336/EEC und 93/68/EEC.

**DECLARATION DE CONFORMITE**  
Nous déclarons sous notre seule responsabilité que l'appareil auquel se réfère cette déclaration est conforme aux standards suivants: EN60065, EN55013, EN55020, EN60555-2 et EN60555-3  
D'après les dispositions de la Directive 73/23/EEC, 89/336/EEC et 93/68/EEC.

**DICHIARAZIONE DI CONFORMITÀ**  
Dichiaro con piena responsabilità che questo prodotto, al quale la nostra richiesta di omologazione si riferisce, è conforme alle seguenti normative: EN60065, EN55013, EN55020, EN60555-2 e EN60555-3  
In conformità con le disposizioni della direttiva 73/23/EEC, 89/336/EEC e 93/68/EEC. AL D.M. 28/08/95 n. 548.

**DECLARACIÓN DE CONFORMIDAD**  
Declaramos bajo nuestra exclusiva responsabilidad que este producto a que hace referencia esta declaración, está conforme con los siguientes estándares: EN60065, EN55013, EN55020, EN60555-2 y EN60555-3  
Seguendo las provisiones de las Directivas 73/23/EEC, 89/336/EEC y 93/68/EEC.

**BEVOORDELIJGHEIDSVERKLARING**  
Wij verklaaren uitsluitend op onze verantwoordelijkheid dat dit product, waarop deze verklaring betrekking heeft, overeenstemming is met de volgende normen: EN60065, EN55013, EN55020, EN60555-2 en EN60555-3  
Volgens de bepalingen van de Richtlijnen 73/23/EEC, 89/336/EEC en 93/68/EEC.

**OVERENSSTÄMMELSEINTYG**  
Härmed intygas, helt på eget ansvar att denna produkt, till vilken detta intyg avser, uppfyller följande standarder: EN60065, EN55013, EN55020, EN60555-2 och EN60555-3  
Enligt sågarna i direktiv 73/23/EEC, 89/336/EEC och 93/68/EEC.

**DECLARAÇÃO DE CONFORMIDADE**  
Declaramos sob nossa exclusiva responsabilidade que este produto, ao qual esta declaração se refere, está em conformidade com as seguintes normas: EN60065, EN55013, EN55020, EN60555-2 e EN60555-3  
De acordo com o estabelecido nas Diretivas 73/23/EEC, 89/336/EEC e 93/68/EEC.

**FRONT PANEL  
VORDERSEITE  
PANNEAU AVANT  
PANNELLO FRONTALE**

**PANEL ANTERIOR  
VORPANEEL  
FRONT PANEEL  
PAINEL FRONTAL**

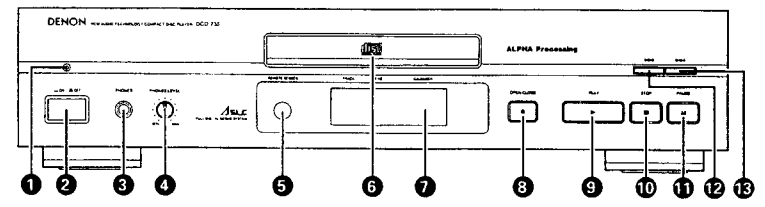

**REMOTE CONTROL UNIT  
FERNBEDIENUNG  
UNITE DE TÉLÉCOMMANDE  
TELECOMANDO  
MANDO A DISTANCIA  
AFSTANDBEDIENING  
FJÄRRKONTROLL  
UNIDADE DE TELECOMANDO**

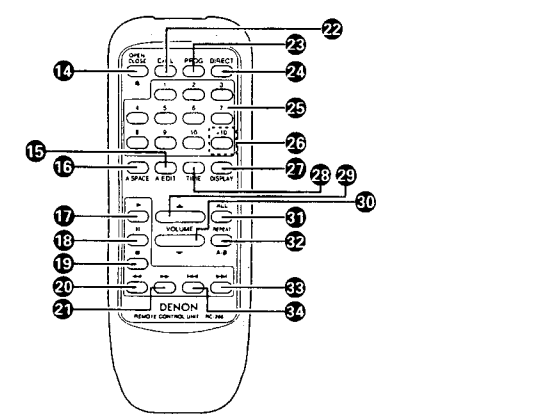

**REAR PANEL  
RÜCKSEITE  
PANNEAU ARRIÈRE  
PANNELLO POSTERIORE**

**PANEL POSTERIOR  
ACHTERPANEEL  
BAKSIDAN  
PAINEL TRASEIRO**

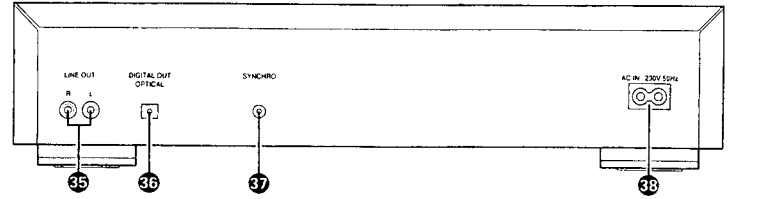

**OPERATING INSTRUCTIONS**

Thank you for purchasing this DENON Compact Disc Player. Please read the operating instructions thoroughly in order to acquaint yourself with the CD player and achieve maximum satisfaction from it.

## — TABLE OF CONTENTS —

FEATURES	4
NAMES AND FUNCTIONS OF PARTS	5, 6
CONNECTION	7
OPENING AND CLOSING THE DISC HOLDER AND LOADING A DISC	7
NORMAL CD PLAYBACK	8
ADVANCED CD PLAYBACK	8-10
TIMER-CONTROLLED PLAYBACK	10
THE COMPACT DISC	11
PLAYBACK USING THE REMOTE CONTROL UNIT	11
INSTALLATION PRECAUTIONS	12
TROUBLESHOOTING	12
SPECIFICATIONS	12

Please check to make sure the following items are included with the main unit in the carton:

- |                                |   |
|--------------------------------|---|
| (1) Operating Instructions     | 1 |
| (2) Connection Cord            | 1 |
| (3) Remote Control Unit RC-266 | 1 |
| (4) 6RP AA Dry Cell Battery    | 2 |
| (5) AC Cord                    | 1 |

## FEATURES

The DCD-735/635 are CD players which use DENON's unique S L C (Super Linear Converter) for eliminating loss of sound quality in the PCM playback section to offer playback of the same sounds as those in the studio or hall where the CD was recorded. In addition, the use of carefully selected parts makes this a high performance CD player reproducing the original sound field with rich musical expression.

- Ultimate signal reproduction thanks to the newly developed alpha processor (DCD-735 only)**  
The high speed interpolation operations of the newly developed alpha processor reproduce the LSB (lowest significant bit) data lost from the disc upon recording to provide a smooth waveform. The audible effects of alpha processing are particularly great during playback at low levels at the instant the sound fades out.
- Double Super Linear Converter**  
The use of DENON's unique system and D/A converters with excellent resolution to prevent zero cross distortion, the main cause of reduced sound quality in the PCM playback system, make for sound field reproduction with rich musical expression.
- High Performance Digital Filter**  
The DCD-735/635 use independent D/A converters for the left and right channels and an 8 x oversampling high precision digital filter to bring out the best of the analog filter and offer clear, crisp sound.
- Full Digital Servo System**  
The DCD-735/635's Full Digital Servo System is capable of achieving the optimum servo adjustment to match each disc that is played. This feature ensures that the listener enjoys the highest possible quality in sound that a CD can offer. When the remote control switch is turned on or the disc holder is closed, the adjustment is completed automatically before reproducing the sound.
- Simple Playback of 8 cm CD Singles**  
8 cm CD singles can be played without using an adaptor.
- Wireless Remote Control Accessory**  
In addition to general operations such as Play, Stop and Pause, this remote control unit enables direct selection, direct programming, and other functions. Use of the remote control unit adds greatly to the operating ease of the DCD-735/635, enhancing its outstanding features.
- Synchronized Recording Function**  
Connect the SYNCHRO jack with a DENON cassette deck which is equipped with a SYNCHRO jack, then make a synchronized recording.
- Digital Output (OPTICAL)**  
The data on the compact disc is output in digital format, so the music can be reproduced on an external digital processor or D/A unit.

## NAMES AND FUNCTIONS OF PARTS

- Power Operation Indicator**
    - The LED indicates the set's operating status.
    - AC power source is connected and Power Operation Switch is on** (On Red)
    - AC power source is connected and Power Operation Switch is off** (Off)
    - AC power source is disconnected:** Off
  - Power Operation Switch**
    - When the power operation switch is turned on, "1 00" appears on the TRACK NO. display, and if no disc is loaded, "1 000000" appears on the digital display.
    - If the power operation switch is turned on with a disc already loaded, the total number of tracks on the disc is displayed on the TRACK NO. display, the total time is displayed on the TIME display, the numbers on the music calendar light up to the number of tracks on the disc, and playback begins.
    - Whenever the power operation switch is in the OFF state, the apparatus is still connected on AC line voltage. Please be sure to unplug the cord when you leave home for, say, a vacation.
  - Headphones Jack (PHONES)**
    - For private listening, you can connect your headphones to this jack. Do not raise the volume level too much when listening through headphones. (Headphones are sold separately.)
  - Volume Control (PHONES LEVEL)**
    - Use this to adjust the output level of the headphones.
  - Remote Control Sensor (REMOTE SENSOR)**
    - This sensor receives the infrared light transmitted from the wireless remote control unit.
    - For remote control, point the supplied remote control unit RC-266 towards this sensor.
    - When a signal is transmitted from the remote control unit, the remote control indicator in the display will light up briefly.
  - Disc Holder**
    - Place the disc on the disc holder with the label facing up.
    - Use the open/close button (OPEN/CLOSE) to open and close the disc holder.
    - The disc holder may also be closed by pressing the play button (PLAY) or pause button (PAUSE).
  - Display**
    - The digital display is divided into sections, such as displays for track number, playback time and calendar, as shown below.
- 
- Open / Close Button (OPEN / CLOSE)**
    - The disc holder is opened and closed by pressing this button.
    - Press this button once to open the disc holder, and once again to close it.
    - When the disc holder is closed with a disc loaded, the disc will rotate for a couple of seconds while the disc contents are read. The number of tracks and total playback time on the disc are then displayed on the digital display.

- Play Button (PLAY)**
  - Press this button to start playback of a disc.
  - When this button is pressed, [PLAY] is displayed, and the track number being played is displayed together with the elapsed playback time of the track.
  - Tracks are shown on the calendar display. Once a track has been played, the corresponding track number goes out on the calendar display.
- Stop Button (STOP)**
  - Press this button to stop playback. The disc will stop rotating, and the number of tracks and total playing time of the disc are displayed on the TRACK NO. and TIME displays, respectively.
  - In case programmed playback is engaged when this button is pressed, the number of tracks and total playing time of the program are displayed.
- Pause Button (PAUSE)**
  - Press this button to stop playback temporarily.
  - If this button is pressed during playback, playback is stopped temporarily, the [PAUSE] indicator goes out and the [PAUSE] indicator lights.
  - Press this button or the play button (PLAY) again to continue playback.
- Automatic Search Reverse Button (SEARCH REVERSE)**
  - Press this button to return the pickup to the beginning of the present track. Press again to return to other tracks.
  - By pressing the button a number of times, the pickup will move back the corresponding number of tracks.
- Automatic Search Forward Button (SEARCH FORWARD)**
  - Press this button to move the pickup forward to the beginning of the next track. Press again to move ahead to other tracks.
  - By pressing the button a number of times, the pickup will advance the corresponding number of tracks.
- Open / Close Button (OPEN / CLOSE)**
  - Refer to Open / Close Button.
- Auto Edit Button (A. EDIT)**
  - The tracks on a CD are automatically split into two halves, Side A and Side B, like an analog disc, with the division at the place between tracks which is closest to 1/2 the total playing time, and with the tracks remaining in the same order.
  - When this button is pressed in the stop mode, the total playing time for the first half and the track numbers on the calendar are displayed for approximately 2 seconds. Next, the same is done for the second half, after which the unit is automatically set to the pause mode at the beginning of the first track of the second half which was previously displayed. When the PLAY or PAUSE button is pressed again, playback begins, and the unit is automatically set to the stop mode at the end of the last track on the disc.
  - This function will only work for discs with a total of 20 tracks or less. Also, when this function is used the mode is automatically set to the program mode, so direct search is not possible.
  - The auto edit function is cleared when the STOP button is pressed.
  - The data for the total playing time recorded on the disc and the actual total playing time of the tracks differ, so there may be a difference between the time displayed in the stop mode (the total playing time) and the total of the times of the first and second halves in the auto edit mode (about 2 seconds).

**16 Auto Space Button (A. SPACE)**

- Pressing this button will cause the [A. SPACE] indicator to light and a blank space of approximately 4 seconds is inserted between tracks during CD playback. Pressing the button once more, the [A. SPACE] indicator goes out and the Auto Space feature is cancelled.
- When one of the track search buttons (◀◀ or ▶▶) is pressed, the Auto Space function will not operate.
- The Auto Space function will work during normal playback as well as programmed playback.
- Although 4-second blanks are inserted between tracks, this additional time is not reflected by the indication on the time remaining display or time display when the Auto Edit function is engaged.

**17 Play Button (▶ PLAY)**

- Refer to ▶ Play Button.

**18 Pause Button (⏸ PAUSE)**

- Refer to ⏸ Pause Button.

**19 Stop Button (■ STOP)**

- Refer to ■ Stop Button.

**20 Manual Search Reverse Button (◀◀)**

- Press this button during playback for fast reverse search. As long as the button is kept pressed, music signals are played back faster than normal.
- Pressing this button when the pause mode is engaged, you can quickly reverse the pickup to a desired position, three times faster compared to manual reverse search during playback. During this time, no sound is heard.

**21 Manual Search Forward Button (▶▶)**

- Press this button during playback for fast forward search. As long as the button is kept pressed, music signals are played back faster than normal.
- Pressing this button when the pause mode is engaged, you can quickly forward the pickup to a desired position, three times faster compared to manual forward search during playback. During this time, no sound is heard.

**22 Checking Programmed Contents Button (CALL)**

- By pressing this button on the remote control unit, programmed contents will be displayed. Tracks entered into the memory, will be displayed starting from the first track entered, and will advance one step at a time each time this button is pressed.

**23 Program Button (PROG)**

- Press this button when you want to enter tracks for programmed playback. (Refer to page 8, 9 for details.)

**24 Direct Button (DIRECT)**

- Press this button when you want to cancel programmed playback.

**25 Number Buttons (1, 2, 3, 4, 5, 6, 7, 8, 9 and 10)**

- Use these buttons for the direct search and program memory functions.
- For direct search, press for example button [3] if you want to hear track number 3. For track number 12, press [±10] then [2]. To program tracks, press the PROG button [PROG] to set to the program mode.

**26 +10 Button (+10)**

- Press this button first when selecting track numbers over 10. Use it together with the number buttons [1-9]. For example, to select track number 15, press [±10] then [5]. For track number 33, press [±10] three times, then press [3].

**27 Dimmer Button (DISPLAY)**

- Press this button to change the brightness of the display.
- Press once to make the display 2/3 as bright as normal.
- Press again to make the display 1/3 as bright.
- Press once again to turn the entire display off during playback and all but the track number off in any other mode.

**28 Time Mode Button (TIME)**

- This button is used to select the desired indication on the TIME display. The indication on this display will change each time the button is pressed.
- Normally, the elapsed playback time of the current track is displayed. Pressing the button once, [SINGLE] is displayed and the remaining time of the current track is displayed.
- Pressing once more, [TOTAL] is displayed, and total playing time of remaining tracks is displayed. However, when programmed play is in progress, the total remaining time of the program is displayed.
- Press the button once again to return to the normal display of the elapsed playback time of the current track.

**29 Volume Up Button (▲)**

- The level of the Output Terminals output can be varied. Pressing this button increases the volume.

**30 Volume Down Button (▼)**

- The level of the Output Terminals output can be varied. Pressing this button decreases the volume.

**31 Repeat All Button (ALL)**

- Press this button to repeat playback of all tracks.
- When this button is pressed, [REPEAT] lights on the display and all tracks on the disc or in a program will be repeatedly played back. Press this button once more to disengage the Repeat All function.

**32 A-B Repeat Button (A-B)****Repeating playback of a desired interval**

- Start playback and press the A-B button when you reach the starting point of the interval. The [A-B] indicator starts blinking.
- Continue playback or advance the pickup using the Automatic search Forward button (▶▶) or Manual search Forward button (▶▶) until the ending point is reached. Then press the A-B button once more. The [A-B] indicator will light.
- The pickup will now return to the starting point and repeat playback of the selected interval.
- This interval will be repeated until the A-B repeat mode is cancelled by pressing the A-B repeat button. The [A-B] indicator goes out.
- A-B repeat playback is not possible during programmed playback.

**33 Automatic Search Forward Button (▶▶)**

- Refer to ▶▶ Automatic Search Forward Button.

**34 Automatic Search Reverse Button (◀◀)**

- Refer to ◀◀ Automatic Search Reverse Button.

**35 Output Terminal (LINE OUT)**

- Connect these jacks to the input jacks on your amplifier. (Refer to page 7 for details on the connections.)

**36 Digital Output Jack (OPTICAL)**

- This jack outputs digital data.
- We recommend using an optical link cable (available in stores) for connections.

**37 SYNCHRO Jack**

- To make a synchronized recording, this jack must be connected to the SYNCHRO jack of the deck with a connection cord. (See Page 7 for connections.)

**38 AC INLET**

- Connect the included AC cord here.

**Continuous Button Operation**

If the automatic search reverse button (◀◀), the automatic search forward button (▶▶) or the +10 button (+10) are held in, the function of that button will be repeated.

**CONNECTION****(1) Connecting the Output Terminal (LINE OUT)**

Use the included pin cords to connect the left (L) and right (R) output terminal (LINE OUT) of the DCD-735/635 to the CD, AUX, or TAPE PLAY left (L) and right (R) input jacks of the amplifier.

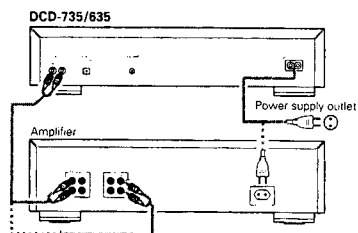
**Connection Precautions**

- Before proceeding with connections or disconnections of cables and power cords, be sure to turn all system components off.
- Ensure that all cables are connected properly to the L (left) and R (right) jacks.
- Insert plugs fully into the terminals.
- Connect the output jacks to the amplifier CD, AUX or TAPE PLAY input jacks.

**(2) SYNCHRO Jack Connections**

Connect the SYNCHRO jack with a DENON cassette deck which is equipped with a SYNCHRO jack, then make a synchronized recording. Use the connection cord supplied with the cassette deck. To make use of this function, also connect the output jacks and make the settings so that a recording can be made from the CD player to the cassette deck.

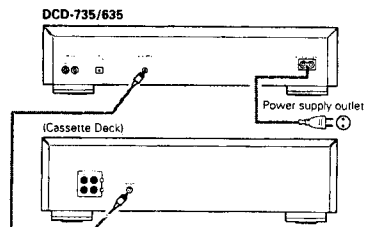
**(3) Connecting the Digital Output Jack (OPTICAL)**

Use an optical link cable to connect the digital output jack (OPTICAL) of the DCD-735/635 to the digital input jack (OPTICAL) on a digital processor or D/A converter unit, available in stores.

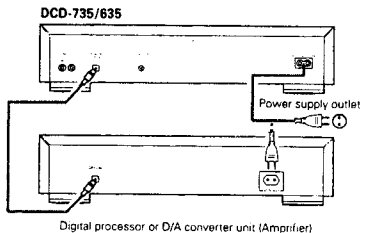
**OPENING AND CLOSING THE DISC HOLDER AND LOADING A DISC**

Opening and closing the disc holder (This operation only works while the power is on.)

- Press the power switch (POWER) to turn on the power.
- Press the open/close button (▲ OPEN/CLOSE).

**How to load a disc**

- Make sure the disc holder is completely opened.
- Hold the disc by the edges and place it on the disc tray (Do not touch the signal surface, i.e., the glossy side).
- When using 12 cm diameter discs, make sure the outer edge matches the tray guide circumference (Fig. 1), and when using CD singles (8 cm diameter) match the outer edge with the inner tray guide circumference (Fig. 2).
- Press the open/close button (▲ OPEN/CLOSE) to close the disc holder.
- When the disc holder is closed, the disc is read and after a few seconds the number of tracks and total playing time are displayed on the TRACK NO. and TIME displays, respectively.
- When the disc holder is open and a disc is loaded, you may also press the play (▶ PLAY) or pause (⏸ PAUSE) button to close the disc holder. (If the play button (▶ PLAY) is pressed, playback will start immediately upon the disc contents having been read.)

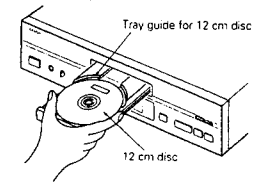
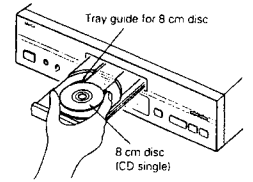
**Fig. 1****Fig. 2****Caution:**

- If your finger should get caught in the disc holder when it closes, press the open/close button (▲ OPEN/CLOSE).
- Do not place any foreign objects on the disc tray, and do not place more than one disc on the tray at a time. Otherwise malfunction may occur.
- Do not push in the disc tray manually when the power is off as this may cause malfunction and damage the CD player.

## NORMAL CD PLAYBACK

### (1) Starting Playback



- Press the power switch (POWER) to turn on the power
- Load the disc you want to play
- When the disc holder is closed, the disc is read and the number of tracks and total playing time of the disc are displayed
- Press the play button (▶ PLAY)

### (2) Stopping Playback

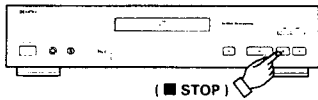

- Press the stop button (■ STOP)
- When all tracks have been played on a disc, playback will stop by itself

#### Precautions:

- If no disc has been loaded or the disc has been placed upside down, all indicators will light
- When the information on the disc cannot be read correctly, for example due to dust or dirt on the disc, the indicators will read as shown below. Nothing will be shown on the TRACK NO. and TIME displays, and it may take quite a while to read the disc

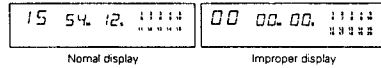

Normal display      Improper display

## ADVANCED CD PLAYBACK

### (1) Playing a Specific Track ..... Direct Search

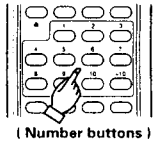

- Use the number buttons and the +10 button to input the number of the desired track
- For example, to play track number 4, press [4], and to play track number 12, press [10] and [2]. Playback will begin from that track

### (2) Advancing to the next track during playback ..... Automatic Search



- Press the Automatic search forward button (▶▶) during playback
- The pickup will advance to the beginning of the next track, and playback will continue. Pressing the button several times will forward the pickup the corresponding number tracks

### (3) Returning to the beginning of the current track during playback ..... Automatic Search



- Press the Automatic search reverse button (◀◀) during playback
- The pickup will return to the beginning of the current track and playback will continue. Pressing the button several times will return the pickup the corresponding number tracks

### (4) Playing Specific Tracks in a Specific Order ..... Programmed Play

- With this function, you can choose any of the tracks on the disc and program them to play in any order
- Programming is possible with the disc holder open
- Up to 20 tracks can be programmed
- The programmed tracks are shown on the calendar

#### 1. Programming

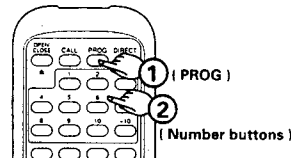

- Press the PROG button so that the [PROG] indicator lights, then use the number buttons and the +10 button to program the tracks
- For example, to program tracks 3, 12, and 7, press [PROG], [3], [10], [7] and [7]
- The corresponding track number lights on the calendar each time a track is programmed, the track number is displayed on the TRACK NO. display, and the total playing time of the programmed tracks is displayed on the TIME display. A few seconds after the last track has been programmed, the total number of tracks programmed is displayed on the TRACK NO. display and the total playing time of the programmed tracks is displayed on the TIME display

### (2) Checking the Programmed Tracks

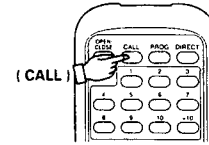

- Press the CALL button
- The programmed tracks are displayed in order on the TRACK NO. display each time the CALL button is pressed

### (3) Playing the Programmed Tracks



- Press the (▶ PLAY) button to play the tracks in the programmed order

### (4) Clearing the Program

- The entire program is cleared when the PROG button is pressed again. The program is also cleared when the OPEN/CLOSE button is pressed
- If the PROG button is pressed during programmed play, the program is cleared and playback continues normally through to the last track on the disc

#### NOTES

- If programming is done in the play or pause mode, the track currently playing is programmed at the first position. Other tracks can be added to the program, but the number of programmed tracks and the playing time will not be displayed
- Direct search is not possible during programmed play. If the number buttons are pressed, that track is added to the end of the program
- Programming is possible with the disc holder open. Track numbers greater than the number of tracks recorded on the disc can be programmed, but will be automatically cleared before playback begins
- The remaining time per track will only be displayed for track numbers 1 through 20
- The total program time and remaining program time are not displayed if tracks greater than track number 20 are programmed

### (5) Repeating playback ..... Repeat

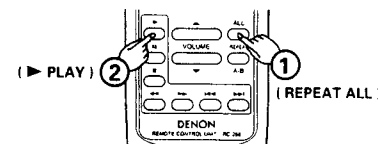

- Press the repeat button (REPEAT ALL)
- Press the play button (▶ PLAY)
- Pressing the repeat all tracks button (REPEAT ALL), [REPEAT] is displayed
- Steps ① and ② above may be reversed
- To cancel repeat playback of all tracks, press the repeat button (REPEAT ALL) once more
- Pressing the repeat button (REPEAT ALL) during programmed playback, playback of the tracks entered into the memory will be repeated

### (6) Pausing playback at any point ..... Pause

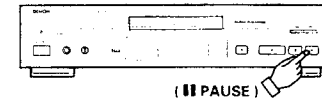

- Playback can be temporarily halted and then continued from the same point in the track
- Press the pause button (|| PAUSE) during playback
- To continue playback, press the play button (▶ PLAY) or the pause button (|| PAUSE) once more

### (7) Audible quick search ..... Manual Search

- Using this function, you can cue to a desired point within a track, either in the forward or reverse direction
- Release the manual search button (◀◀ or ▶▶) when the desired point has been reached. Normal playback then continues

#### 1. Manual Search Forward

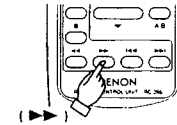

- Press the manual search forward button (▶▶) during playback. Playback of the track is sped up
- As a reference, the current track number and elapsed playback time within the track are displayed
- Manual search forward is approximately three times faster when engaged during the pause state compared to playback. In this case, no sound is heard however
- If the manual search forward button (▶▶) is kept pressed after the end of the final track on the disc is reached, [JJ] is displayed and manual search stops. To return to another point, press the manual search reverse button (◀◀) until [JJ] disappears

#### 2. Manual Search in Reverse

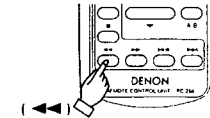

- Press the manual search reverse button (◀◀) during playback. Reverse playback of the track is sped up
- As a reference, the current track number and elapsed playback time within the track are displayed
- Manual search in reverse is approximately three times faster when engaged during the pause state compared to playback. In this case, no sound is heard however
- If the manual search reverse button (◀◀) is kept pressed after the beginning of the first track on the disc is reached, [CC] is displayed and manual search stops. To return to another point, press the manual search forward button (▶▶) until [CC] disappears

**(8) Inserting blanks between tracks** ..... **Auto Space**

- This is convenient feature that will insert 4-second blanks between tracks, which can be used when recording compact discs on tape

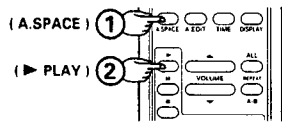

1. Pressing the auto space button (A.SPACE) will cause the (A.SPACE) indicator to light
2. Press the play button (▶PLAY) to start playback  
When a track has been played to its end, a 4-second silence is made before the next track starts playing.
3. Press the auto space button (A.SPACE) again to cancel the function.

**(9) Searching and Pausing at the Beginning of the Track** ..... **Pause**

**① With Direct Search**

- In this case, the set pauses at the beginning of the track found with the direct search operation

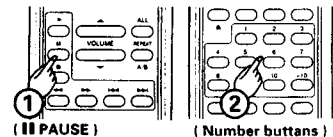

1. Press the (|| PAUSE) button.
2. Press the number button(s) for the desired track
- To start playback, press the (▶PLAY) or (|| PAUSE) button.

**② With Program Search**

- Press the (|| PAUSE) button after the program search operation is completed. The set will pause at the beginning of the first programmed track

**(10) Synchronized Recording Function** ..... **Synchronized Recording Function**

Connecting the SYNCHRO jack with a DENON cassette deck which is equipped with a SYNCHRO jack will allow synchronized recordings to be made.

- To use this function, be sure to connect the SYNCHRO jacks as well as the output jacks. (See Page 7 for connections.) Then, load a disc
- With the CD player in the stop or pause condition, starting a synchronized recording at the cassette deck side will automatically cause the CD player to start playing. (This is synchronized play.)
- The remote control signal receive indicator of the display will blink during synchronized play.

**NOTE**

- Synchronized play is also possible in the program mode.
- The repeat mode is cancelled when synchronized play is started
- Except for the STOP, PLAY, TIME, A.SPACE and DISPLAY buttons, the buttons will not operate during synchronized play
- To use this function in the AUTO EDIT condition, use the longer tape than total playing time of the disc.
- To use this function with AUTO EDIT function. Be sure to complete the setting of AUTO EDIT function with [PAUSE] indication on the Display. Then start the synchronized recording function.
- In the play condition, even if you start a synchronized recording at the cassette deck side, CD player will not synchronize with the cassette deck and the cassette deck becomes synchronized pause condition. In this case push the STOP button of the cassette deck, set the CD player in the stop or pause condition and start a synchronized recording at the cassette deck side again
- For further details, see the owner's manual for the cassette deck that has been connected

**TIMER-CONTROLLED PLAYBACK**

**■ Operation**

1. Turn on the power of all system components.
2. Set the input selector on the amplifier to correspond to the inputs the CD player is connected to.
3. Make sure a disc has been loaded in the disc holder.
4. Check the time on the timer and then set the desired turn-on time.
5. Turn the audio timer ON.  
Power is turned off automatically in all components connected to the timer.
6. When the preset turn-on time is reached, power is turned on in the system components, and CD playback starts from the first track.

**■ Connection**

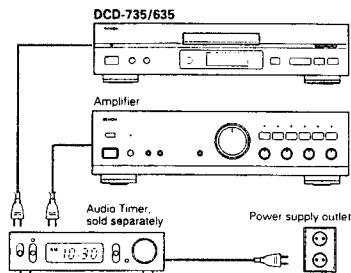

**THE COMPACT DISC**

**1. Precautions on handling compact discs**

- Do not allow fingerprints, oil or dust on the surface of the compact disc. If the signal surface is dirty, wipe it off with a soft, dry cloth. Wipe in circular motions from the center and out.
- Do not use water, benzene, thinner, record sprays, electrostatic proof chemicals, or silicone-treated cloth to clean discs
- Always use care when handling discs to prevent damaging the surface, in particular when removing a disc from the case and returning it
- Do not bend compact discs
- Do not apply heat to compact discs
- Do not enlarge the hole in the center of the disc.
- Do not write on the disc and do not attach any labels
- Condensation will form on the disc surface if it is brought into a warm room from a cold area, such as outdoors during winter. Wait until the condensation disappears. Never dry discs with hair dryers, etc.

**2. Precautions on storage**

- After playing a disc, always return it to its case
- Keep discs in the cases when they are not to be played. This will protect them from dust and dirt and prolong their service life
- Do not store discs in the following places:
  - 1) Places exposed to direct sunlight for a considerable time
  - 2) Places subject to accumulation of dust or high humidity
  - 3) Places exposed to high temperatures, such as close to heater outlets

**PLAYBACK USING THE REMOTE CONTROL UNIT**

The accessory RC-266 remote control unit can be used to control the CD player from a convenient distance

**(1) Inserting the dry cell batteries**

1. Remove the battery cover on the back of the remote control unit

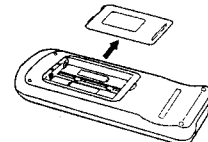

2. Insert two R6P (standard size AA) dry cell batteries with correct polarity as indicated inside the battery compartment

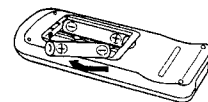

3. Replace the battery cover

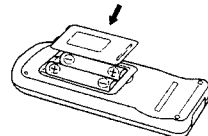

**Notes on the Batteries**

- The remote control unit uses standard size AA dry cell batteries
- The batteries will need to be replaced approximately once a year. Replacement may be necessary earlier depending on how much the remote control unit is used
- If, in less than a year from the time new batteries were inserted, the remote control fails to operate the CD player from a near-by position, it is time to replace the batteries
- Insert the batteries properly, following the polarity diagram inside the battery compartment, in other words make sure (+) and (-) terminals are properly aligned
- Batteries are prone to damage and leakage. Therefore:
  - Do not combine new batteries with used ones
  - Do not combine different types of batteries
  - Do not jumper opposite poles of the batteries, expose them to heat, break them open nor expose of them in open fire
- If the remote control unit is not to be used for a long period of time, remove the batteries from the unit
- If the batteries have leaked, remove any traces of battery fluid from the battery compartment, wiping thoroughly with a dry cloth. Then insert new batteries

**(2) Directions for Use**

- Operate the remote control unit while pointing it towards the remote control sensor on the CD player (see below). When a remote control signal is received, the remote control indicator on front of the CD player lights briefly
- The remote control unit can be used at a distance up to 8 meters in a straight line from the CD player. This distance decreases if there are obstructions blocking the signal path or when the remote control unit is operated at an angle from the remote control sensor
- The buttons on the remote control unit have identical functions with those on the CD player. However, the following functions cannot be remote controlled: Power ON/OFF

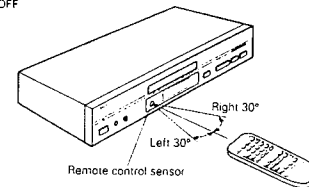

**Notes on Operation**

- Do not press identical buttons on the CD player and remote control unit simultaneously as this may cause malfunction
- The remote control unit may be difficult to operate if the remote control sensor is exposed to strong light, such as direct sunlight or light from fluorescent lamps, or if there are obstacles between the remote control unit and the sensor.
- **Direct track selection**  
Using the track number buttons (1 ~ 10, +10) tracks can be directly assigned for playback.
- **Track selection while programming**  
Press the program button (PROG) and then the track numbers you wish to enter into the memory.  
Example: PROG → 3 → +10 & 1 → 5  
(Tracks 3, 11, 5 and so on are entered into the memory.)  
Memorized tracks are erased by pressing the Direct button (DIRECT)
- **Correct use of the track number buttons**  
Direct selection of single-digit tracks is easy by just pressing the desired track number button. For tracks with numbers from 11 and on, first press the +10 button and then a single-digit button. E.g., to select track 22, press the +10 button twice and then press the 2 button

## INSTALLATION PRECAUTIONS

The CD player uses a microcomputer for controlling internal electronic circuits. In the event that the player is used while a near-by tuner or TV is turned on, although unlikely, interference could occur either in the sound from the tuner or the picture of the TV. To avoid this, please take the following precautions.

- Keep the CD player as far away from the tuner or TV set as possible.
- Keep the power cable and connecting cable of the CD player separate from the antenna wires of the tuner and TV.
- Interference is particularly likely to occur when an indoor antenna or a 300  $\Omega$ /ohm feeder cable is used. Thus, use of an outdoor antenna and 75  $\Omega$ /ohm coaxial cable is strongly recommended.



300  $\Omega$ /ohm feeder cable



75  $\Omega$ /ohm coaxial cable

## TROUBLESHOOTING

If the CD player does not seem to be functioning properly, check the following:

### Disc holder does not open or close.

- Is the power on?

### When a disc is loaded, 00 00 00 is displayed.

- Is the disc loaded properly? See page 7

### When the play button (▶) is pressed, playback does not start.

- Is the disc dirty or scratched? See page 11

### There is no sound, or it is distorted.

- Is the output cord properly connected to the amplifier? See page 7
- Have the amplifier controls been set correctly?

### A specific section of the disc will not play.

- Is the disc dirty or scratched? See page 11

### Programmed playback does not work.

- Have programming been properly done? See pages 8 and 9

### Incorrect operation when buttons on the remote control are pressed.

- Is the remote control unit being operated too far from the CD player? See page 11
- Are there obstacles blocking the ray?
- Is the remote control sensor exposed to strong light?
- Are the batteries exhausted?

## SPECIFICATIONS

### AUDIO

	DCD-735	DCD-635
No. of Channels:	2 channels	
Frequency Response:	2 ~ 20,000 Hz	
Dynamic Range:	100 dB	98 dB
Signal-to-noise Ratio:	110 dB	107 dB
Harmonic Distortion:	0.0025% (1 kHz)	0.003% (1 kHz)
Separation:	103 dB (1 kHz)	100 dB (1 kHz)
Wow & Flutter:	Below measurable limit: ( $\pm 0.001\%$ W peak)	
Output Voltage:	0.2 ~ 2.0 V	

### DISCS

Compact Disc format

### GENERAL CHARACTERISTICS

Power Supply:	50 Hz ~ 230 V
Power Consumption:	10 W
Dimensions:	434 (17-3/32") W x 100 (3-59/64") H x 283 (11-5/32") D mm
Weight:	4.1 kg

### FUNCTIONS AND DISPLAY

Functions:	Automatic search, programmed playback, repeat playback, manual search, auto space, time mode, auto edit, dimmer
Display:	Track number, time, music calendar, emphasis feature and engaged modes
Others:	Headphones jack

### REMOTE CONTROL UNIT

Remote Control System:	RC-266 Infrared pulse system
Power Supply:	3 V DC, two R6P (standard size AA) dry cell batteries
External Dimensions:	54.5 (2-1/8") W x 140 (5-1/2") H x 24.8 (31/32") D mm
Weight:	85 g (including batteries)

\* Design and specifications are subject to change without notice in the course of product improvement.

## DISASSEMBLY

(To reassemble reverse disassembly)

### 1. LOADER PANEL

As removing loader panel in power OFF status, use a screw driver to insert the hole of set bottom side and rotate counterclockwise ①, pull out disc table ②, then detach Loader panel ③.

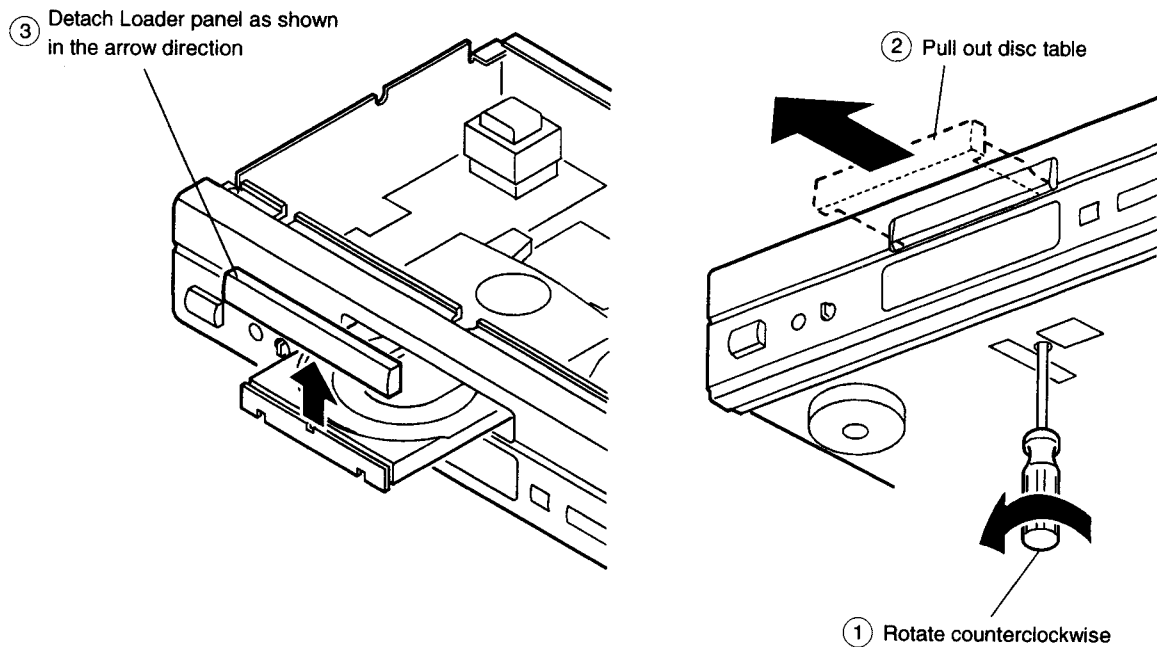

### 2. TOP COVER

1. Remove a Screw ④.
2. Remove 4 screws ⑤.

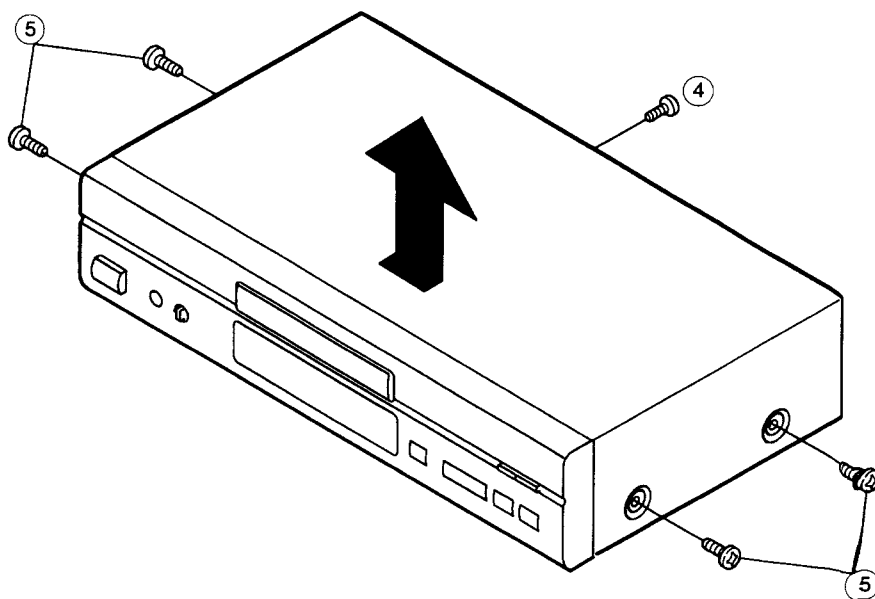



### 3. FRONT PANEL

1. Remove 2 screws (6) .
2. Undo the hooks at 3 places.

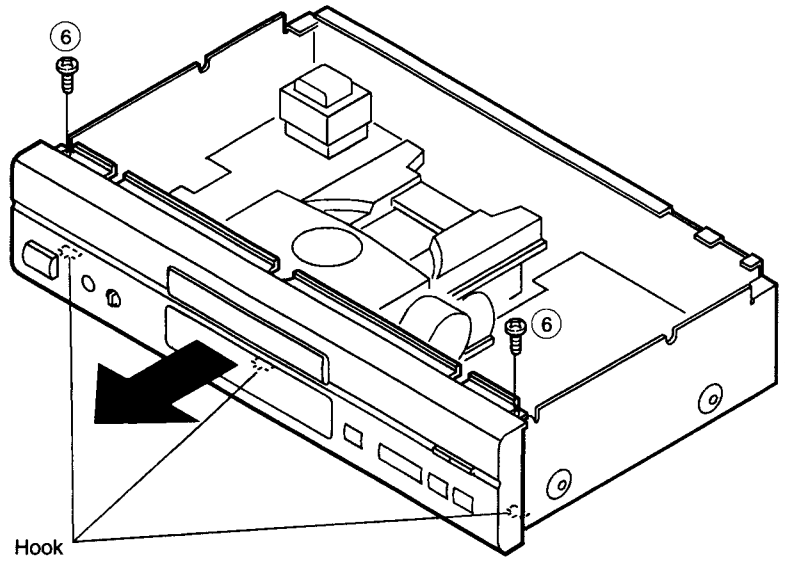

### 4. REAR PANEL

1. Remove 2 screws (7) .
2. Remove 3 screws (8) .
3. Remove 4 screws (9) .

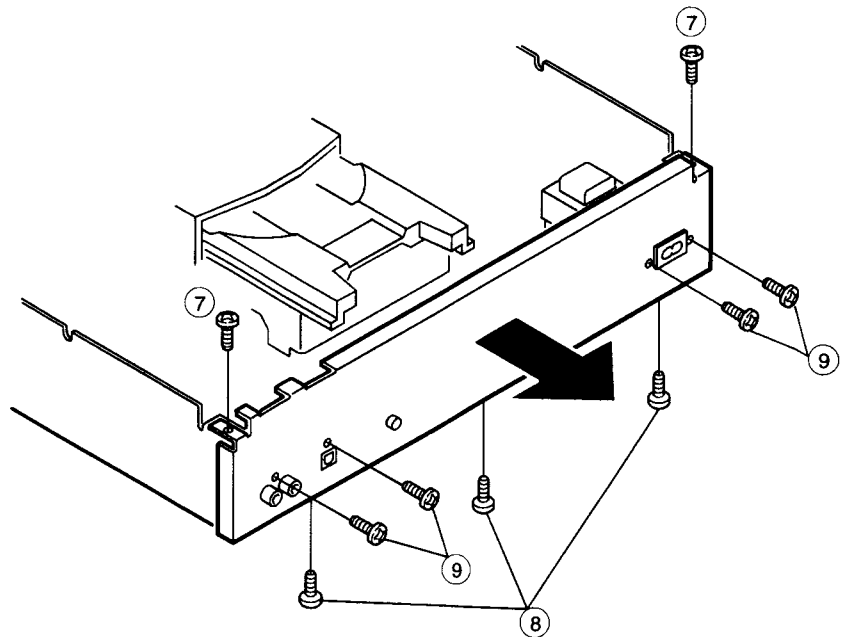

## CONFIRMING METHOD OF SERVO

A microcomputer adopted to this unit has the service programs so as to perform confirming more easily with the operation buttons. Digital servo adopted to this unit becomes automatic adjustment status in focus gain and tracking gain.

### 1. Actuating the Service Program

- (1) Turn power switch OFF.
- (2) Shortcircuit the main unit JV125 (OUT) to JV124 (IN).
- (3) Turn power switch ON.  
(Service program start actuates and displays track No. 0 1)

**Note:** The operation buttons do not function when service program actuates.

### 2. Operation Function at Service Program Actuation

Button Operation	Operation Function	Explanation				
▲ OPEN/CLOSE	Opens or closes disc holder button.	<ul style="list-style-type: none"> <li>● Opens or closes only when disc is stopped.</li> <li>● Operate other keys after open or close.</li> </ul>				
■ STOP	Stops system function.	<ul style="list-style-type: none"> <li>● Displays track number 0 1.</li> <li>● Press when adjustment completed or do it again.</li> </ul>				
PAUSE	(1) Starts Focus servo and disc turns.	<ul style="list-style-type: none"> <li>● Press when tracking adjustment.</li> <li>● When completed, displays track number 0 2.</li> </ul>				
	(2) Starts Focus servo, Tracking servo, Slide servo and Spindle servo.	<ul style="list-style-type: none"> <li>● Pressing PAUSE button, starts Tracking servo and slide servo.</li> <li>● When completed, displays track number 0 3.</li> </ul>				
	(3) Displays a result of Focus gain automatic adjustment.	<ul style="list-style-type: none"> <li>● After completed PAUSE operation, pressing PAUSE again indicates a result of Focus gain automatic adjustment.</li> <li>● When completed, display shows:               <table style="margin-left: auto; margin-right: auto; border: none;"> <tr> <td style="text-align: center;">TRACK</td> <td style="text-align: center;">TIME</td> </tr> <tr> <td style="text-align: center;">1 -</td> <td style="text-align: center;">VV VV VVVVVV</td> </tr> </table> </li> <li>TIME display shows automatic adjustment value.</li> <li>Displays: 0 1H2 7<sub>5</sub>~00H0 1<sub>5</sub> or EEH0 1<sub>5</sub></li> </ul>	TRACK	TIME	1 -	VV VV VVVVVV
	TRACK	TIME				
	1 -	VV VV VVVVVV				
	(4) Displays a result of Tracking gain automatic adjustment.	<ul style="list-style-type: none"> <li>● After completed PAUSE operation, pressing PAUSE again indicates a result of Tracking gain automatic adjustment.</li> <li>● When completed, display shows:               <table style="margin-left: auto; margin-right: auto; border: none;"> <tr> <td style="text-align: center;">TRACK</td> <td style="text-align: center;">TIME</td> </tr> <tr> <td style="text-align: center;">2 -</td> <td style="text-align: center;">VV VV VVVVVV</td> </tr> </table> </li> <li>TIME display shows automatic adjustment value.</li> <li>Displays: 0 1H2 7<sub>5</sub>~00H0 1<sub>5</sub> or EEH0 2<sub>5</sub></li> </ul>	TRACK	TIME	2 -	VV VV VVVVVV
TRACK	TIME					
2 -	VV VV VVVVVV					
(5) Displays a result of Focus BIAS automatic adjustment.	<ul style="list-style-type: none"> <li>● After completed PAUSE operation, pressing PAUSE again indicates a result of Focus BIAS automatic adjustment.</li> <li>● When completed, display shows:               <table style="margin-left: auto; margin-right: auto; border: none;"> <tr> <td style="text-align: center;">TRACK</td> <td style="text-align: center;">TIME</td> </tr> <tr> <td style="text-align: center;">3 -</td> <td style="text-align: center;">VV VV VVVVVV</td> </tr> </table> </li> <li>TIME display shows automatic adjustment value.</li> <li>Displays: -0H3 1<sub>5</sub>~+0H3 1<sub>5</sub> or EEH0 3<sub>5</sub></li> </ul>	TRACK	TIME	3 -	VV VV VVVVVV	
TRACK	TIME					
3 -	VV VV VVVVVV					
(6) Displays a result of EF BALANCE automatic adjustment.	<ul style="list-style-type: none"> <li>● After completed PAUSE operation, pressing PAUSE again indicates a result of EF BALANCE automatic adjustment.</li> <li>● When completed, display shows:               <table style="margin-left: auto; margin-right: auto; border: none;"> <tr> <td style="text-align: center;">TRACK</td> <td style="text-align: center;">TIME</td> </tr> <tr> <td style="text-align: center;">4 -</td> <td style="text-align: center;">VV VV VVVVVV</td> </tr> </table> </li> <li>TIME display shows automatic adjustment value.</li> <li>Displays: -2H5 5<sub>5</sub>~+2H5 5<sub>5</sub> or EEH0 4<sub>5</sub></li> </ul>	TRACK	TIME	4 -	VV VV VVVVVV	
TRACK	TIME					
4 -	VV VV VVVVVV					
Other Buttons	Unable to obtain normal function.	<ul style="list-style-type: none"> <li>● Never attempt to operate the buttons other than the above.</li> <li>● If the buttons are erroneously pressed, promptly turn OFF the power switch.</li> </ul>				

#### (Caution)

- During the service program is in operation, do not use remote control.

### 3. Confirming Method

#### (1) Required Measuring Equipment

- 1) Dual-trace oscilloscope
- 2) Test disc: CA-1094

#### (2) Check Point

CD Mechanical unit PWB (pattern view)

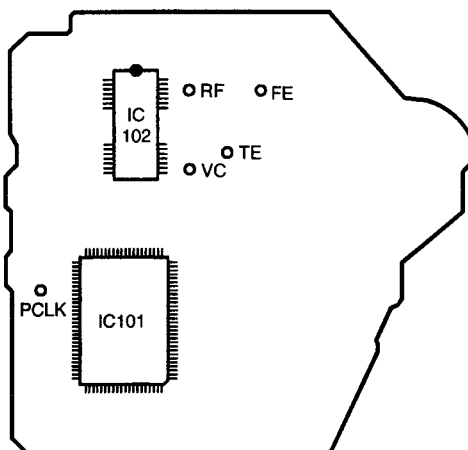

#### (3) Confirming Procedure

- 1) Actuate the service program.
- 2) Check for Tracking offset.
- 3) Check the value of Focus gain automatic adjustment.
- 4) Check the value of Tracking gain automatic adjustment.
- 5) Check for Focus BIAS.
- 6) Check for EF BALANCE.
- 7) Finish the service program and return the mode to normal operation (turn ON the power switch in normal manner).
- 8) Check for HF level.

#### (4) Confirming Tracking Offset

Oscilloscope		Check	Step
Connection			
V	H	(Oscilloscope)	<ol style="list-style-type: none"> <li>1. Push <b>▲ OPEN/CLOSE</b> button and load disc holder reference disk.</li> <li>2. Push <b>▲ OPEN/CLOSE</b> button and close disc holder.</li> <li>3. Push <b>   PAUSE</b> button to turn disc. (Displays track number <math>\text{⓪ 2}</math>)</li> <li>4. Short (+) (-) of oscilloscope and check the base line.</li> <li>5. Confirm that upper and lower amplitude of the waveform is symmetric against 0V.</li> </ol>
0.1v/div	1 ~ 2 ms/div	$\frac{A-B}{A+B} < 30\%$	

## (5) Confirming Focus Gain

- 1) Press **PAUSE** button twice. (Track No. indication 0 3 )
- 2) Press **PAUSE** button. (Track No. indication 1 - )
- 3) Check for automatic adjustment value.

Automatic adjustment value: 00m82s ~ 00m34s (normal temperature) (Test disc: CA-1094)  
01m04s ~ 00m28s (0°C~40°C)

**Note:** As it is a possibility of abnormality in pick-up when automatic adjustment value is EEm01s or less than 00m27s, execute the confirmation for pick-up according to pick-up replacement standard.  
If there is no abnormality in pick-up as described in pick-up replacement standard notes, no problem will occur for disc playback even though the automatic adjustment value is EEm01s or less than 00m27s.

## (6) Confirming Tracking Gain

- 1) Press **PAUSE** button twice. (Track No. indication 0 3 )
- 2) Press **PAUSE** button twice. (Track No. indication 2 - )
- 3) Check for automatic adjustment value.

Automatic adjustment value: 00m86s ~ 00m27s (normal temperature) (Test disc: CA-1094)  
01m07s ~ 00m22s (0°C~40°C)

**Note:** As it is a possibility of abnormality in pick-up when automatic adjustment value is EEm02s or less than 00m22s, execute the confirmation for pick-up according to pick-up replacement standard.

If there is no abnormality in pick-up as described in pick-up replacement standard notes, no problem will occur for disc playback even though the automatic adjustment value is EEm02s or less than 00m22s.

## (7) Confirming Focus BIAS

- 1) Press **PAUSE** button twice. (Track No. indication 0 3 )
- 2) Press **PAUSE** button three times. (Track No. indication 3 - )
- 3) Check for automatic adjustment value.

Automatic adjustment value: 1m20s ~ -0m20s

## (8) Confirming EF BALANCE

- 1) Press **PAUSE** button twice. (Track No. indication 0 3 )
- 2) Press **PAUSE** button four times. (Track No. indication 4 - )
- 3) Check for automatic adjustment value.

Automatic adjustment value: 1m50s ~ -1m21s

## (9) Confirming HF Level

Connection			
<div style="text-align: center;"> </div>			
Oscilloscope		Check	Step
V	H	(Oscilloscope)	
50mv/div	0.2μ/div	<p style="text-align: center;">A=1.54~0.85V</p>	<ol style="list-style-type: none"> <li>1. Push <b>PAUSE</b> button twice. (Displays track number 0 3 )</li> <li>2. Check HF level of oscilloscope.</li> <li>3. Confirm that the waveform is in good shape. (eye pattern in center must be able to discriminate clearly.)</li> </ol>
or 20mv/div	or 0.5μ/div		
<ul style="list-style-type: none"> <li>• Set input mode to ALTERNATE or CHOPPER.</li> </ul>			

## TEST METHOD FOR HEAT RUN MODE

### 1. Actuate

While hold pushing ►, ■ and || buttons simultaneously, turn the unit power on. The remote control sensor indicator will light to show that the unit is shifted in Heat Run mode.

Press the ▲ button to cancel Heat Run mode after loading disc.

### 2. Operation

#### 1) Heat Run test

During the Heat Run mode to start in Play mode, it makes the unit replays from the first track after opens the loader when finishing with playing last track. After that, this operation is over again. When disc has over 21 tracks, makes the unit to search the last track and set operation times.

#### 2) Checking test

Press [PAUSE] button 2 times in the Heat Run mode, it makes the unit opens the loader, turns the servo ON, reads out TOC, operates first track search and does over again.

#### 3) Sound out test

During the Heat Run mode, press +10 button to start in Play mode. If it generates over  $\pm 8$  frame sound out, stop the operate and display the error message.

### 3. Error Message

When the system error occurs in the Heat Run mode, display the error message with TRACK and operated times with TIME.

- |             |  |
|-------------|--|
| 1) E1 error | Focus Servo does not activate.                     |
| 2) E2 error | GFS does not drive.                                |
| 3) E3 error | No GFS emit.                                       |
| 4) E4 error | TOC is unreadable.                                 |
| 5) E5 error | Does not turn the Loader switch ON.                |
| 6) E6 error | Does not turn the Pick-up inner circle switch OFF. |
| 7) E7 error | Does not turn the Pick-up inner circle switch ON.  |
| 8) E8 error | Sound out.   |

## NOTE FOR HANDING OF THE LASER PICK UP

### Judgement standards for PICK-UP Replacement

#### 1. PICK-UP REPLACEMENT

The pick-up(PU) replacement must be executed upon the following 4 items and found the abnormality in the PU. When PU is abnormal, please write PU abnormality cause for PU sign column of connecting prompt report of market quality state clearly.

##### 1) Judgement by confirming of Focus search

(cause of PU abnormality: Focus search does not function.)

##### 2) Judgement by checking of changing PU due to Focus error signal VFE

(cause of PU abnormality: No proper emission of focus error signal (s-curve) VFE)

##### 3) Judgement by checking of changing PU due to Tracking Error signal VTE

(cause of PU abnormality: No proper emission of tracking error signal (traverse waveform) VTE)

##### 4) Judgement by checking of changing PU due to HF level VHF

(cause of PU abnormality: No proper emission of HF waveform)

#### 2. DISC TO BE USED FOR CONFIRMATION

Using disc: No. CA-1094

#### 3. OTHER CAUSE OF PU CHANGING

If it happened other cause of PU replacement except the above-mentioned 4 items, please execute PU replacement and write this cause for connecting prompt report of market quality state in detail.

**1. Judgement by Confirming of Focus Search  
(Check for focus search function of PU Lens)**

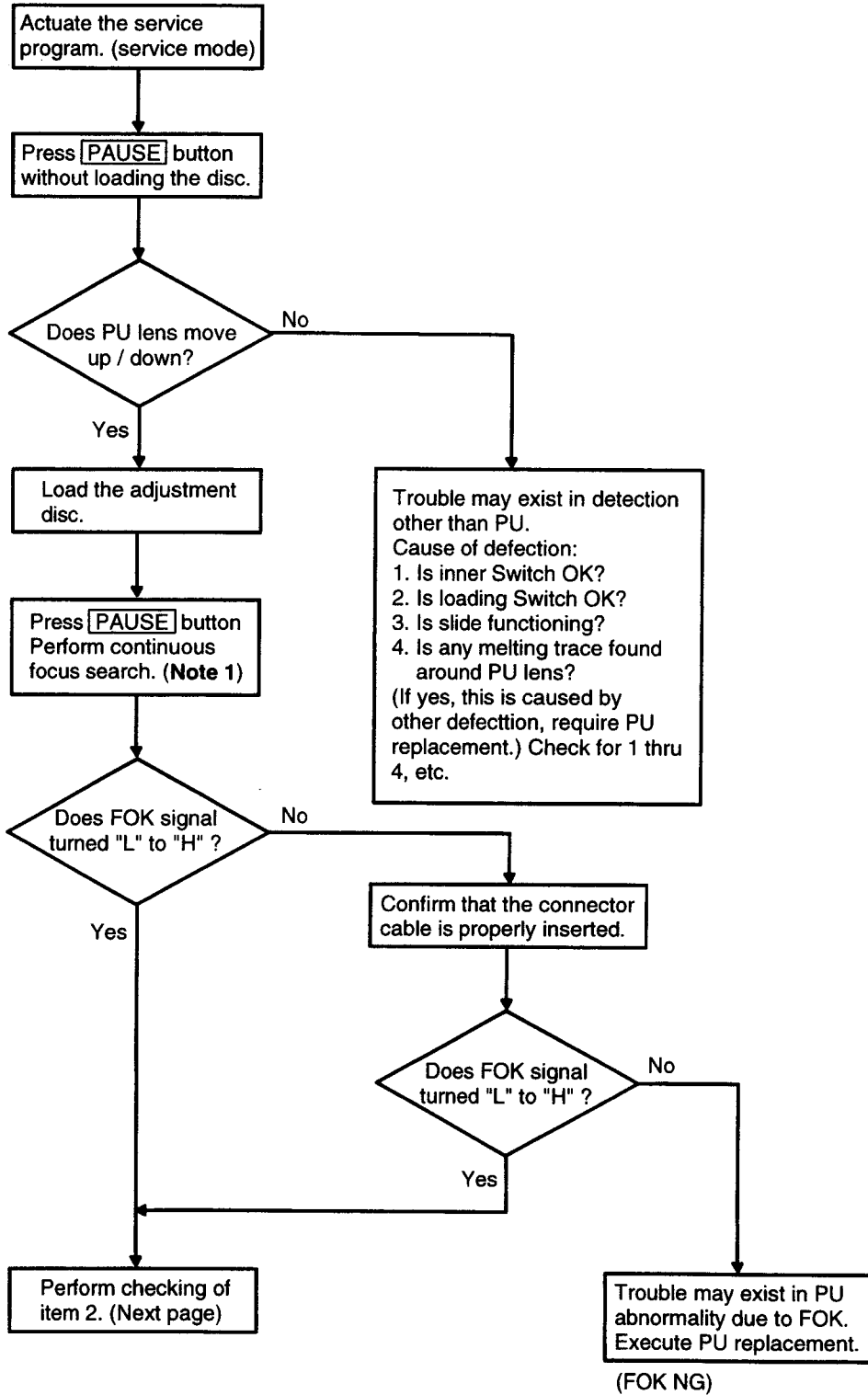

**Note 1:** Press [PAUSE] button continually in FOK measuring.

## 2. Judgement by checking of changing PU due to Focus Error signal VFE (Check for proper S-curve)

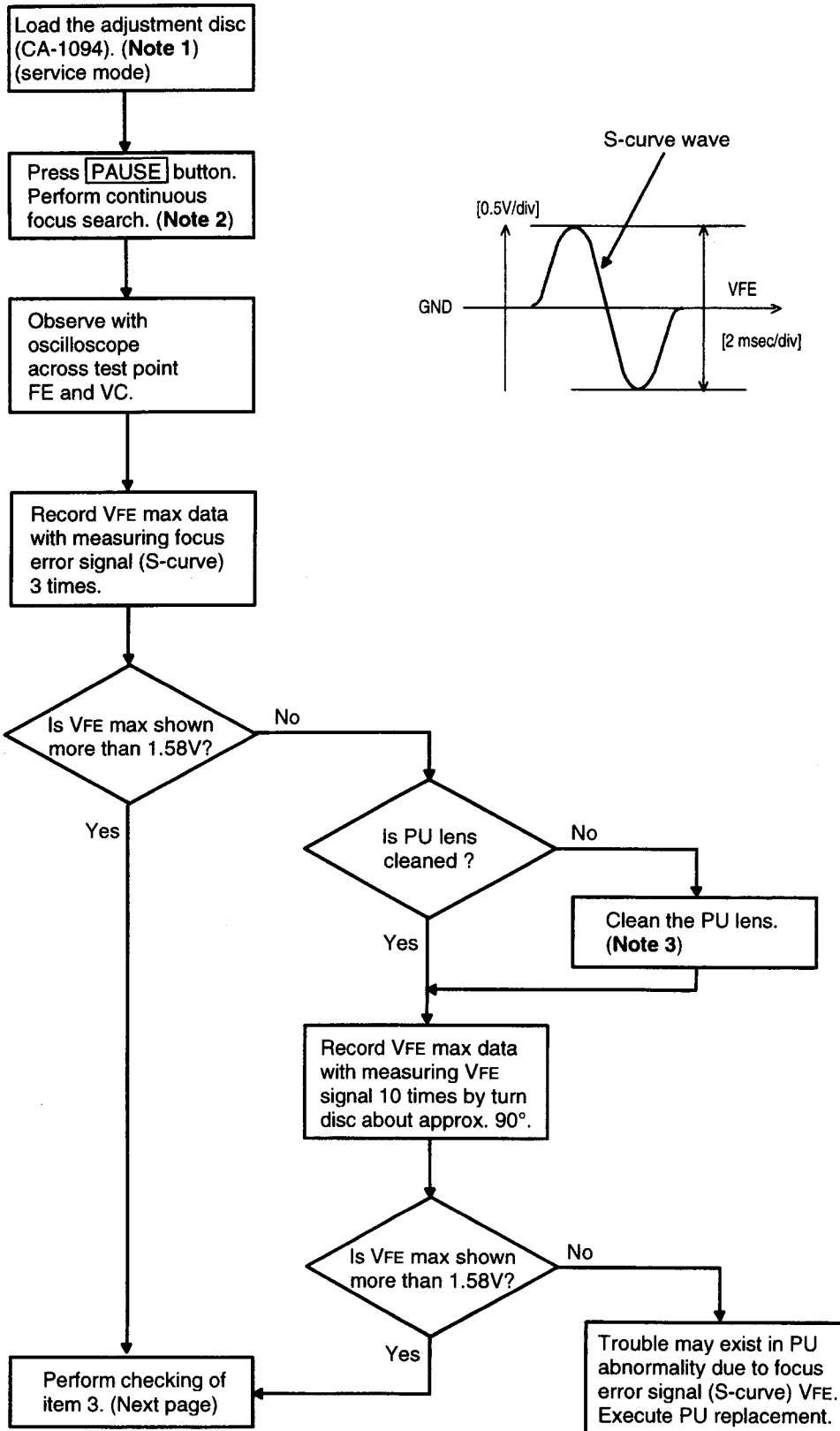

**Note 1:** Adjustment disc (CO-76143) VFE = 1.67 V

**Note 2:** Press [PAUSE] button continually in VFE measuring.

**Note 3:** Gently wipe out the lens surface with a little amount of isopropyl alcohol soaked lens cleaning paper without apply excessive force to the lens.

**3. Judgement by checking of changing PU due to Tracking Error signal VTE  
(Check for proper Traverse waveform)**

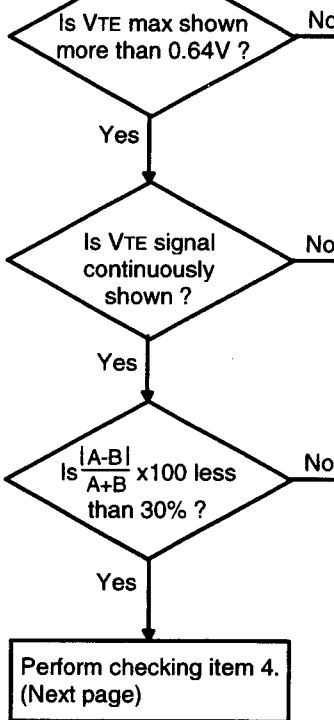
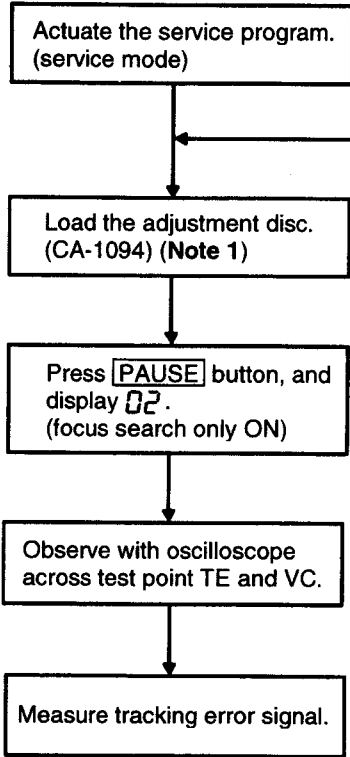

1. Tracking error signal level without undulation.

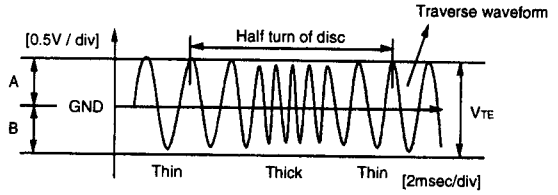

2. Tracking error signal level with undulation.

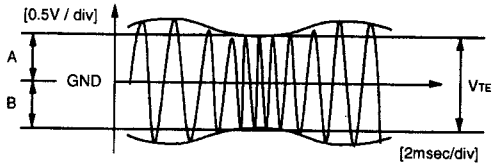

3. Occasionally no tracking error signal level.

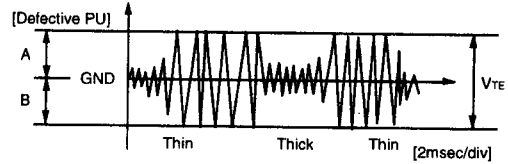

Note 1: Adjustment disc (CO-76143) VTE = 0.70 V



#### 4. Judgement by checking of changing PU due to HF level VHF (Check for proper HF waveform)

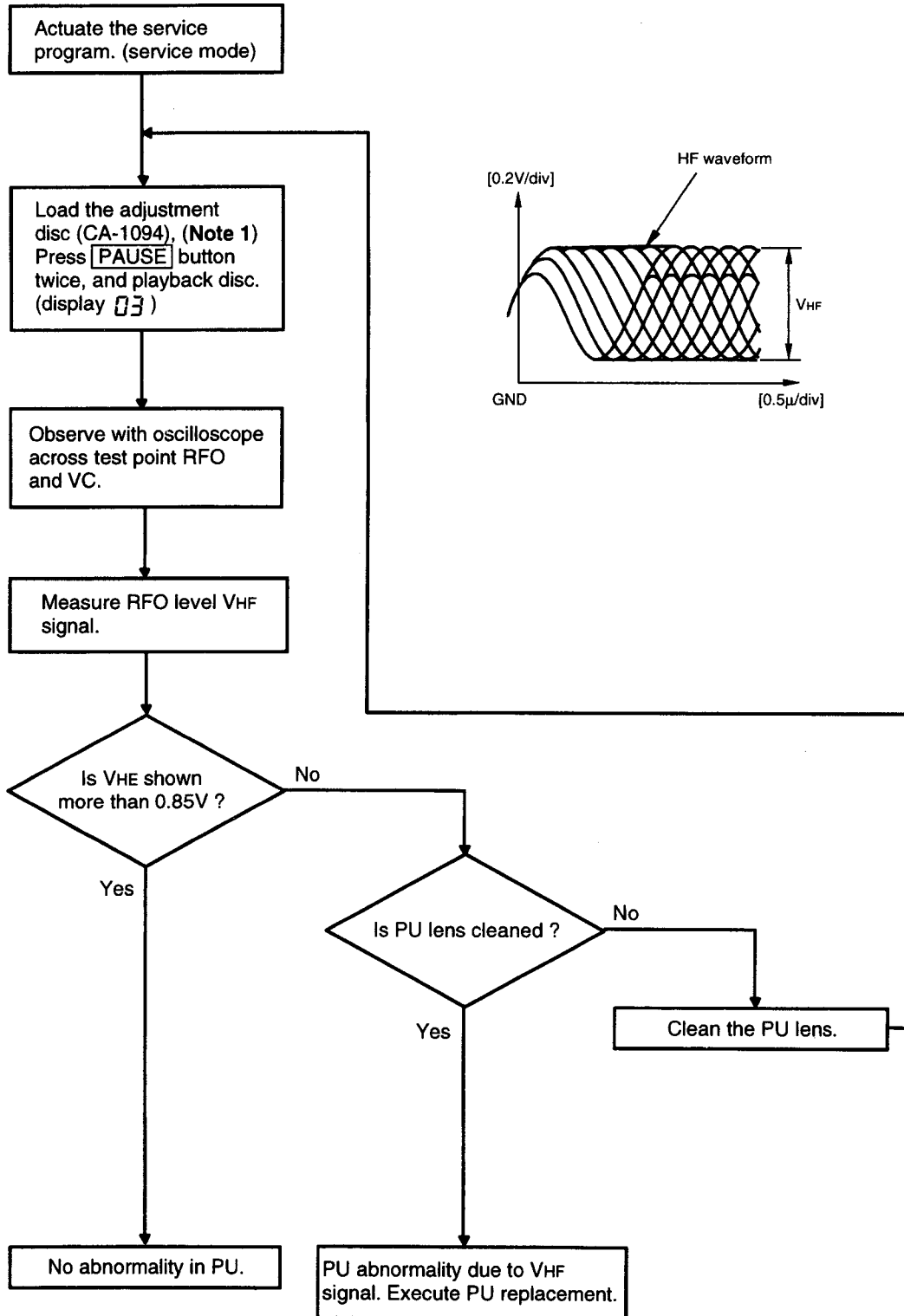

Note 1: Adjustment disc (CO-76143) VHE = 0.85 V.

# SEMICONDUCTORS

● IC's  
BA6392FP

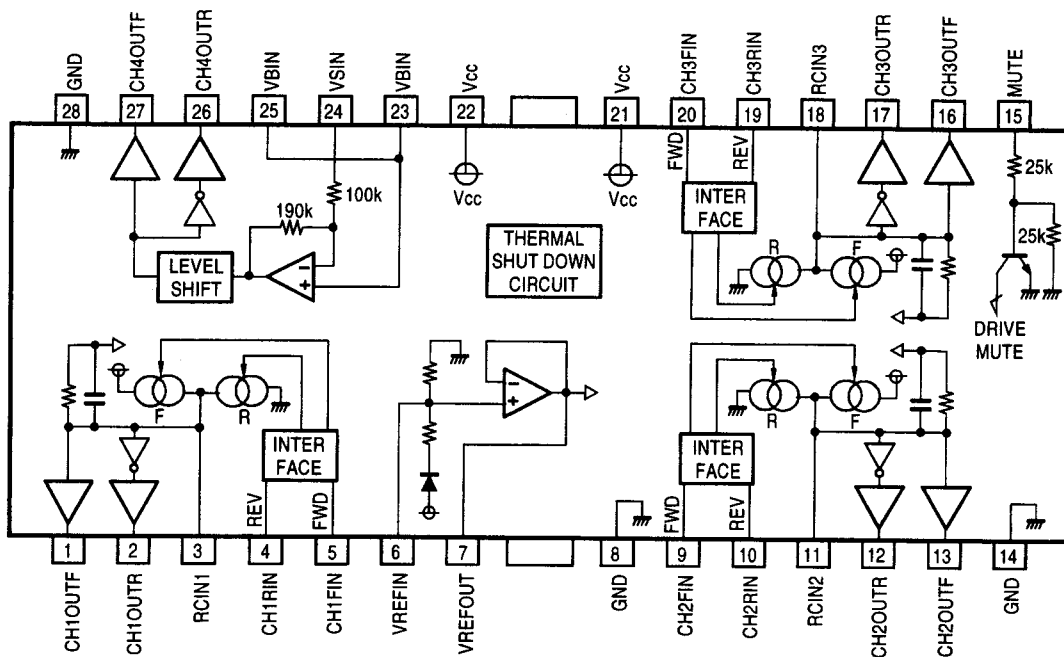
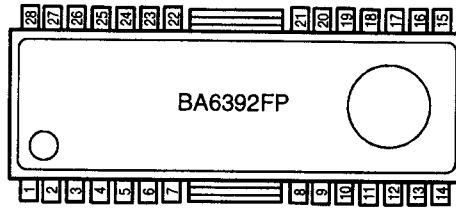
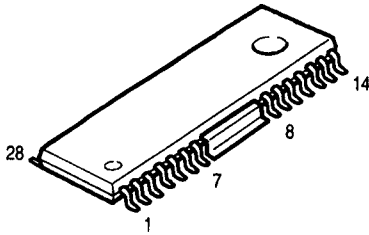

### BA6392FP Terminal Function

Pin No.	Symbol	I/O	Function
1	CH1OUTF	O	CH1 output terminal (+).
2	CH1OUTR	O	CH1 output terminal (-).
3	RCIN1	O	CH1 Pre-Amplifier output terminal.
4	CH1RIN	I	CH1 Pre-Amplifier negative input terminal.
5	CH1FIN	I	CH1 Pre-Amplifier positive input terminal.
6	VREFIN	I	Internal Vref-Amplifier resistor bias terminal.
7	VREFOUT	O	Internal Vref-Amplifier output terminal.
8	GND	—	Vref-Amplifier and constant current ground.
9	CH2FIN	I	CH2 Pre-Amplifier positive input terminal.
10	CH2RIN	I	CH2 Pre-Amplifier negative input terminal.
11	RCIN2	O	CH2 Pre-Amplifier output terminal.
12	CH2OUTR	O	CH2 output terminal (-).
13	CH2OUTF	O	CH2 output terminal (+).
14	GND	—	CH2 and CH3 driver ground.

Pin No.	Symbol	I/O	Function
15	MUTE	I	Driver mute control terminal.
16	CH3OUTF	O	CH3 output terminal (+).
17	CH3OUTR	O	CH3 output terminal (-).
18	RCIN3	O	CH3 Pre-Amplifier output terminal.
19	CH3RIN	I	CH3 Pre-Amplifier negative input terminal.
20	CH3FIN	I	CH3 Pre-Amplifier positive input terminal.
21	Vcc	—	CH2 and CH3 driver power supply.
22	Vcc	—	CH1 and CH4 driver power supply.
23	VBIN	I	CH4 Pre-Amplifier positive input terminal.
24	VSIN	I	CH4 Pre-Amplifier negative input terminal.
25	VBIN	O	CH4 Pre-Amplifier output terminal.
26	CH4OUTR	O	CH4 output terminal (-).
27	CH4OUTF	O	CH4 output terminal (+).
28	GND	—	CH1 and CH4 driver ground.

**Note:** Each driver output polarity is reference to Pre-Amplifier output terminal polarity (+).

## CXD2545Q

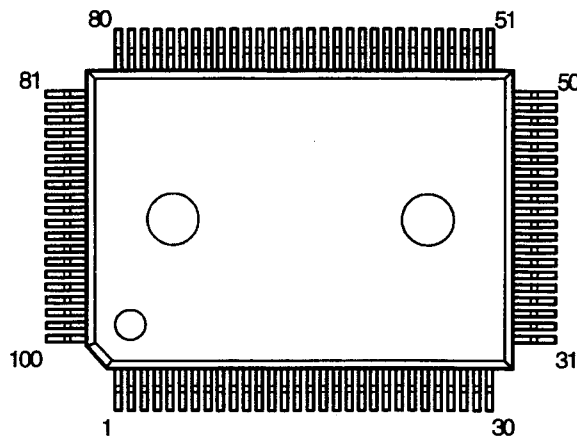

## CXD2545Q Terminal Function

Pin No.	Symbol	I/O	Function
1	SRON	O	Sled drive output signal.
2	SRDR	O	Sled drive output signal.
3	SFON	O	Sled drive output signal.
4	TFDR	O	Tracking drive output signal.
5	TRON	O	Tracking drive output signal.
6	TRDR	O	Tracking drive output signal.
7	TFON	O	Tracking drive output signal.
8	FFDR	O	Focus drive output signal.
9	FRON	O	Focus drive output signal.
10	FRDR	O	Focus drive output signal.
11	FFON	O	Focus drive output signal.
12	VCOO	O	Osc. circuit output for analog EFM PLL.
13	VCOI	I	Osc. circuit input for analog EFM PLL. $f_{\text{lock}}=8.6436\text{MHz}$ .
14	TEST	I	Test terminal, normally GND.
15	Vss	—	Digital GND.
16	TES2	I	Test terminal, normally GND.
17	TES3	I	Test terminal, normally GND.
18	PDO	O	Charge pump output for analog EFM PLL.
19	VPCO	O	PLL charge pump output for variable pitch.
20	VCKI	I	Clock input from external VCO for variable pitch. $f_{\text{center}}=16.9344\text{MHz}$ .
21	AVDD	—	Analog power supply.
22	IGEN	I	Power supply terminal for OP amplifier.
23	AVSS	—	Analog ground.
24	ADIO	I	Open
25	RFC	O	Open
26	RFDC	I	RF signal input. Input range : 2.15V~5.0V (at $V_{\text{DD}}=AV_{\text{DD}}=5.0\text{V}$ ).
27	TE	I	Tracking error signal input. Input range : 2.5V±1.0V (at $V_{\text{DD}}=AV_{\text{DD}}=5.0\text{V}$ ).
28	SE	I	Sled error signal input. Input range : 2.5V±1.0V (at $V_{\text{DD}}=AV_{\text{DD}}=5.0\text{V}$ ).
29	FE	I	Focus error signal input. Input range : 2.5V±1.0V (at $V_{\text{DD}}=AV_{\text{DD}}=5.0\text{V}$ ).
30	VC	I	Center point voltage input terminal.
31	FILO	O	Filter output for master PLL.
32	FILI	I	Filter input for master PLL.
33	PCO	O	Charge pump output for master PLL.
34	CLTY	I	
35	AVS1	—	Analog ground.
36	RFAC	I	EFM signal input.
37	BIAS	I	Asymmetry circuit constant current output.
38	ASYI	I	Asymmetry comparator voltage input.
39	ASYO	O	EFM full swing output (L=Vss, H=VDD).
40	AVDD	—	Analog power supply.

Pin No.	Symbol	I/O	Function
41	DVDD	—	Digital power supply.
42	ASYE	I	Asymmetry circuit ON/OFF (L=OFF, H=ON).
43	PSSL	I	Mode shift input of audio data output. L to serial output, H to parallel output.
44	WDCK	O	48 bit slot D/A interface. word clock $f=2F_s$ .
45	LRCK	O	48 bit slot D/A interface. LR clock $f=F_s$ .
46	DATA		
47	BCLK		
48	64DATA		
49	64BCLK	O	Open
50	64LRCK	O	Open
51	GTOP	O	Open
52	XUGF	O	Open
53	XPLCK	O	Open
54	GFS		
55	RFCK	O	Open
56	C2PO	O	Open
57	XRAOF	O	Open
58	MNT3	O	Open
59	MNT2	O	Open
60	MNT1	O	Open
61	MNT0	O	Open
62	XTAI	I	X'tal Osc. circuit input. L at X'tal is 16.934MHz, H at X'tal is 33.8688MHz.
63	XTAO	O	X'tal Osc. circuit output.
64	XTSL	I	X'tal select input terminal. L at X'tal is 16.934MHz, H at X'tal is 33.8688MHz.
65	DVss	—	Digital ground.
66	FSTI	I	2/3 cycle input of Pin 62, 63.
67	FSTO	O	2/3 cycle output. Does not vary with variable pitch.
68	FEOF	O	Open
69	C16M	O	Open
70	MD2	I	Digital-Out ON/OFF control terminal (L=OFF, H=ON).
71	DOUT	O	Digital-Out output terminal.
72	EMPH	O	Playback disc emphasis mode output (L=with emphasis, H=without emphasis).
73	WFCK	O	WFCCK output.
74	SCOR	O	Sub code sync output terminal (H at either of sub-code sync so or si is detected).
75	SBSO	O	Sub P-W serial output.
76	EXCK	I	Clock input for SBSO read out.
77	SUBQ	O	Sub Q 80 bit output. PCM peak data, level data 16-bit output.
78	SQCK	I	Clock input for SQSO read out.
79	MUTE	I	Mute shift terminal (mute at H).
80	SENS	O	SENS output. Emits to CPU.
81	XRST	I	System reset (reset at L).
82	DIRC	I	Using at 1 track jump.
83	SCLK	I	Clock for SENS serial data read out.
84	DFSW	I	DFCT shift terminal (DFCT measure circuit OFF at H).
85	ATSK	I	Anti-shock terminal.
86	DATA	I	Serial data input from CPU.
87	XLAT	I	Latch input from CPU.
88	CLOCK	I	Serial data transfer clock input from CPU.
89	COUT	O	Number of track count signal output.
90	VDD	—	Digital power supply.
91	MIRR	O	Mirror signal output.
92	DFCT	O	Defect signal output.
93	FOK	O	Focus OK output.
94	FSW	O	Output filter shifting output of spindle motor.
95	MON	O	ON/OFF control output of spindle motor.
96	MDP	O	Servo control of spindle motor.
97	MDS	O	Servo control of spindle motor.
98	LOCK	O	By sampling GFS with 460Hz and when GFS at H, H output. L output at consecutively L 8 times.
99	SSTP	I	Terminal for disc innermost circle detection signal.
100	SFDR	O	Sled rive output.

HD6433724-E64F

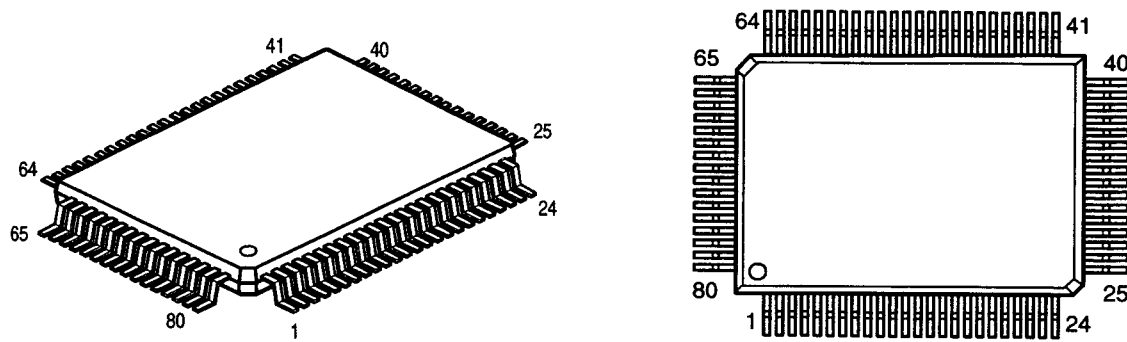

HD6433724-E64F Terminal Function

Pin No.	Terminal Name	Symbol	I/O	Det	Res	Ext	Ini	OP	Function
1	P04/AN4	K3	I	Lv	Z	Pd	—	—	Key matrix input.
2	P05/AN5	K2	I	Lv	Z	Pd	—	—	Key matrix input.
3	P06/AN6	K1	I	Lv	Z	Pd	—	—	Key matrix input.
4	P07/AN7	K4	I	Lv	Z	Pd	—	—	Key matrix input.
5	AVss	AVss	I	—	—	—	—	—	GND
6	TEST	TEST	I	—	—	—	—	—	Connect to GND.
7	X2	—	O	—	Z	—	—	—	Open
8	X1	—	I	—	—	—	—	—	Connect to Voc.
9	Vss	Vss	I	—	—	—	—	—	GND
10	OSC1	OSC1	I	—	—	—	—	—	Connect to ceramic oscillator.
11	OSC2	OSC2	O	—	—	—	—	—	Connect to ceramic oscillator.
12	RES	RESET	I	Lv	—	—	—	—	System reset signal input.
13	P10/IRQ0	REMOTE	I	Ed	Z	—	—	—	Interruption signal from remote control.
14	P11/IRQ1	SENS	I	Lv,Ed	Z	—	—	—	Sense input (CXD2515).
15	P12/IRQ1	SCOR	I	Ed	Z	—	—	—	Interruption input from SUB CODE.
16	P13/IRQ3	SIN. OUT	O	—	Z	—	—	—	Communication output for SINCRO REC.
17	P14/IRQ4	SIN. IN	I	Ed	Z	—	—	—	Communication input for SINCRO REC.
18	P15/IRQ5	NC	O	—	Z	—	—	—	Open
19	P16/EVENT	NC	I	—	Z	—	—	—	GND
20	P33/FS27	NC	I	—	Z	—	—	—	Open
21	P32/FS26	NC	I	—	Z	—	—	—	Open
22	P31/FS25	NC	I	—	Z	—	—	—	Open
23	P30/FS24	NC	O	—	Z	—	L	—	Open
24	P47/FS23	NC	O	—	Z	—	L	—	Open
25	P46/FS22	NC	O	—	Z	—	L	—	Open
26	P45/FS21	NC	O	—	Z	—	L	—	Open
27	P44/FS20	NC	O	—	Z	—	L	—	Open
28	P43/FS19	P(A)	O	—	Z	Pdisp	L	—	Segment output for VFD.
29	P42/FS18	P(B)	O	—	Z	Pdisp	L	—	Segment output for VFD.
30	P41/FS17	P(C)	O	—	Z	Pdisp	L	—	Segment output for VFD.
31	P40/FS16	P(D)	O	—	Z	Pdisp	L	—	Segment output for VFD.
32	P50/FS15	P(E)	O	—	Z	Pdisp	L	—	Segment output for VFD.
33	P51/FS14	P(F)	O	—	Z	Pdisp	L	—	Segment output for VFD.
34	P52/FS13	P(G)	O	—	Z	Pdisp	L	—	Segment output for VFD.
35	P53/FS12	P(H)	O	—	Z	Pdisp	L	—	Segment output for VFD.

Pin No.	Terminal Name	Symbol	I/O	Det	Res	Ext	Ini	OP	Function
36	P54/FS11	P(I)	O	—	Z	Pdisp	L	—	Segment output for VFD.
37	P55/FS10	P(J)	O	—	Z	Pdisp	L	—	Segment output for VFD.
38	P56/FS9	P(K)	O	—	Z	Pdisp	L	—	Segment output for VFD.
39	P57/FS8	P(L)	O	—	Z	Pdisp	L	—	Segment output for VFD.
40	P17/Vdisp	Vdisp	I	—	Z	—	—	—	VEE for VFD.
41	P60/FD0	G8	O	—	Z	Pdisp	L	—	Gird output for VFD.
42	P61/FD1	G7	O	—	Z	Pdisp	L	—	Gird output for VFD.
43	P62/FD2	G6	O	—	Z	Pdisp	L	—	Gird output for VFD.
44	P63/FD3	G5	O	—	Z	Pdisp	L	—	Gird output for VFD.
45	P64/FD4	G4	O	—	Z	Pdisp	L	—	Gird output for VFD.
46	P65/FD5	G3	O	—	Z	Pdisp	L	—	Gird output for VFD.
47	P66/FD6	G2	O	—	Z	Pdisp	L	—	Gird output for VFD.
48	P67/FD7	G1	O	—	Z	Pdisp	L	—	Gird output for VFD.
49	P70/FD8	NC	O	—	Z	—	L	—	Open
50	P71/FD9	NC	I	—	Z	—	—	—	Open
51	P72/FD10	NC	I	—	Z	—	—	—	Open
52	P73/FD11	NC	I	—	Z	—	—	—	Open
53	P74/FD12	NC	I	—	Z	—	—	—	Open
54	P75/FD13	NC	I	—	Z	—	—	—	Open
55	P76/FD14	NC	I	—	Z	—	—	—	Open
56	P77/FD15	NC	I	—	Z	—	—	—	Open
57	Vcc	Vcc	I	—	—	—	—	—	Power supply.
58	P80	A.MUTE	O	—	Z	Pu	H	—	Analog mute output.
59	P81	MDT	O	—	Z	—	L	—	SM5845 or SM5841 control data output.
60	P82	MCK	O	—	Z	—	L	—	SM5845 or SM5841 control bit clock output.
61	P83	MLE	O	—	Z	—	L	—	SM5845 or SM5841 control latch output.
62	P84	OPEN	O	—	Z	—	L	—	CD MECHA. Loader drive signal.
63	P85	CLOSEE	O	—	Z	—	L	—	CD MECHA. Loader drive signal.
64	P86	D.MUTE	O	—	Z	Pu	H	—	Digital mute signal.
65	P87	LD ON	O	—	Z	—	L	—	Laser control signal.
66	P90/PWM	SCLK	O	—	Z	—	H	—	Servo setting value read clock output (CXD2545).
67	P91/SCK1	CLK	O	—	Z	—	H	—	Control clock output (CXD2545).
68	P92/SI1	XLT	O	—	Z	—	H	—	Control latch output (CXD2545).
69	P93/SO1	DATA	O	—	Z	—	H	—	Control data output (CXD2545).
70	P94/SCK2	SQCK	I	—	Z	—	—	—	SUB CODE clock input (CXD2545).
71	P95/SI2	SUBQ	I	—	Z	—	—	—	SUB CODE Q data input.
72	P96/SO2	NC	O	—	Z	—	—	—	Open
73	P97	NC	O	—	Z	—	—	—	735/635 select
74	PA0	MAINS	O	—	Z	—	—	—	ALPHA 1 ON/OFF control to SM5845.
75	PA1	SHFTN	O	—	Z	—	—	—	BIT SHIFT ON/OFF control to SM5845.
76	AVcc	AVcc	I	—	—	—	—	—	Power supply.
77	P00/AN0	OUT SW	I	Lv	Z	—	—	—	Loader open signal (L: open).
78	P01/AN1	IN SW	I	Lv	Z	—	—	—	Loader close signal (L: close).
79	P02/AN2	GFS	I	Lv	Z	—	—	—	GFS input (CXD2545).
80	P03/AN3	FOK	I	Lv	Z	—	—	—	FOK input (CXD2545).

Note:

- I/O: Port input/output direction (I: input, O: output).
- Det: Input level detection mode (Lv: level detection, Ed: edge detection).
- Res: Port state at reset (Z: high impedance).
- Ext: External addition (Pu: external pull up, Pd: external pull down, but mask option is existing).
- Ini: Initial output value.
- Op: Mask option.

**BA15218  
μPC4570C**

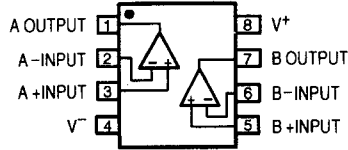
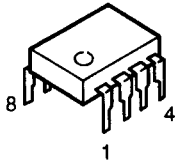

**SM5845AF**

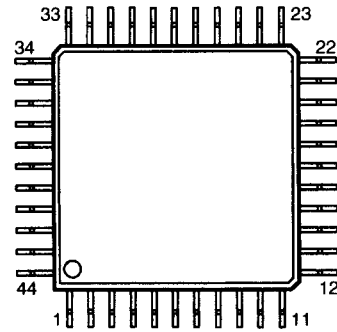

**M5290P  
PCM61P-L**

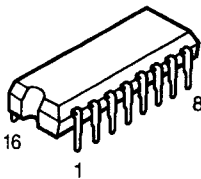

**M5290P**

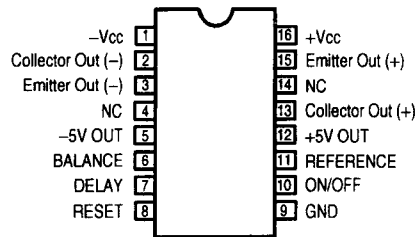

**PCM61P-L**

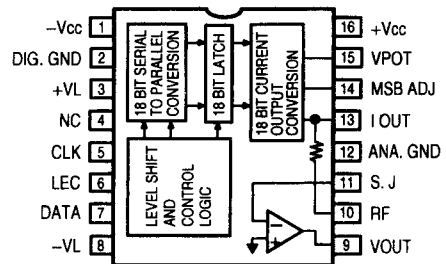

**TC74HCU04AP**

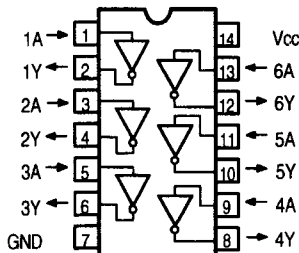
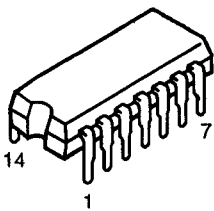

**● IC PROTECTOR  
ICP-N15T**

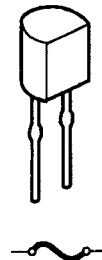

**SBX1910 (Remote Control Receiver)**

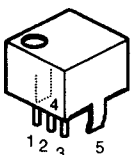

- 1. Vcc
- 2. Output
- 3. GND
- 4. Case Fin
- 5. Case Fin

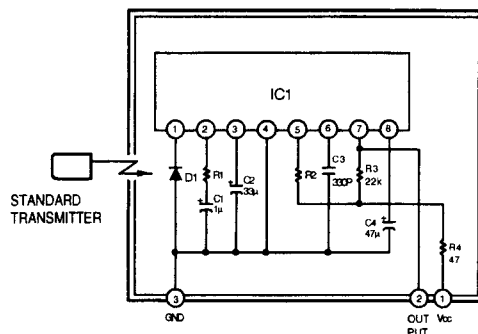

- IC1 : CX20106A Chip
- D1 : PIN Photodiode Chip
- C1, C2, C4 : Aluminum Electrolytic Capacitor
- C3 : SL Characteristic ±5%
- R1 : Gain control resistor
- R2 : for control resistor (Using ±1%)
- R (Other than above items) : ±5%

● TRANSISTORS

2SD1762 (E/F)  
2SB1185 (E/F)

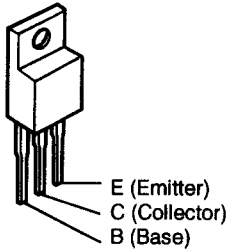

2SD2144

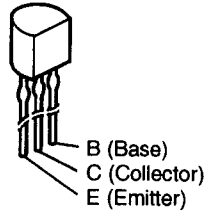

2SA934 (Q)  
2SC2060 (Q)

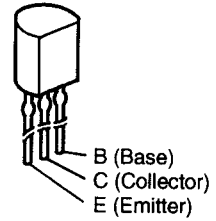

2SA933S (S)  
DTA124XS (22k-47k)  
DTC114ES (10k-10k)  
RN2205 (2.2k-47k)

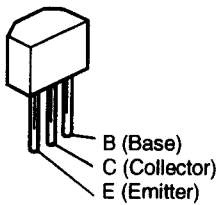

DTA124XS (22k-47k)  
RN2205 (2.2k-47k)

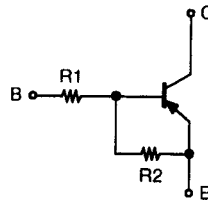

DTC114ES (10k-10k)

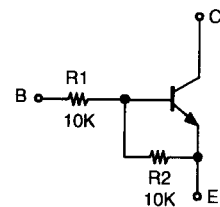

	R1	R2
DTA124XS	22 kohm	47 kohm
RN2205	2.2 kohm	47 kohm

● DIODES

MTZJ6.2A  
MTZJ6.8A  
MTZJ8.2A  
MTZJ24A

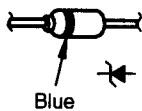

1SR35-200A

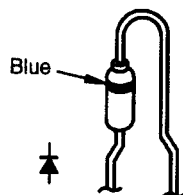

1SS252

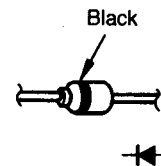

## NOTE FOR PARTS LIST

- Part indicated with the mark "⊙" are not always in stock and possibly to take a long period of time for supplying, or in some case supplying of part may be refused.
- When ordering of part, clearly indicate "1" and "I" (i) to avoid mis-supplying.
- Ordering part without stating its part number can not be supplied.
- Part indicated with the mark "★" is not illustrated in the exploded view.
- Not including Carbon Film ±5%, 1/4W Type in the P.W.Board parts list. (Refer to the Schematic Diagram for those parts.)

**WARNING:**

Parts marked with this symbol  $\triangle$  ████ have critical characteristics.  
Use ONLY replacement parts recommended by the manufacturer.

● **Resistors**

Ex.: RN 14K 2E 182 G FR  
 Type Shape Power Resist- Allowable Others  
 and per- ance error

RD : Carbon	2B : 1/8W	F : ±1%	P : Pulse-resistant type
RC : Composition	2E : 1/4W	G : ±2%	NL : Low noise type
RS : Metal oxide film	2H : 1/2W	J : ±5%	NB : Non-burning type
RW : Winding	3A : 1W	K : ±10%	FR : Fuse-resistor
RN : Metal film	3D : 2W	M : ±20%	F : Lead wire forming
RK : Metal mixture	3F : 3W		
	3H : 5W		

**\* Resistance**

$\overset{1}{\uparrow} \text{8} \overset{2}{\downarrow} \Rightarrow 1800 \text{ ohm} = 1.8 \text{ kohm}$   
 Indicates number of zeros after effective number.  
 2-digit effective number.

• Units: ohm

$\overset{1}{\uparrow} \text{R} \overset{2}{\downarrow} \Rightarrow 1.2 \text{ ohm}$   
 1-digit effective number.  
 2-digit effective number, decimal point indicated by R.

• Units: ohm

● **Capacitors**

Ex.: CE 04W 1H 2R2 M BP  
 Type Shape Dielectric Capacity Allowable Others  
 and per- strength error

CE : Aluminum foil electrolytic	0J : 6.3V	F : ±1%	HS : High stability type
CA : Aluminum solid electrolytic	1A : 10V	G : ±2%	BP : Non-polar type
CS : Tantalum electrolytic	1C : 16V	J : ±5%	HR : Ripple-resistant type
CQ : Film	1E : 25V	K : ±10%	DL : For charge and discharge
CK : Ceramic	1V : 35V	M : ±20%	HF : For assuring high frequency
CC : Ceramic	1H : 50V	Z : +80%	U : UL part
CP : Oil	2A : 100V	-20%	C : CSA part
CM : Mica	2B : 125V	P : +100%	W : UL-CSA type
CF : Metallized	2C : 160V	-0%	F : Lead wire forming
CH : Metallized	2D : 200V	C : ±0.25pF	
	2E : 250V	D : ±0.5pF	
	2H : 500V	= : Others	
	2J : 630V		

**\* Capacity (electrolyte only)**

$\overset{2}{\uparrow} \text{2} \overset{2}{\downarrow} \Rightarrow 2200\mu\text{F}$   
 Indicates number of zeros after effective number.  
 2-digit effective number.

• Units:  $\mu\text{F}$ .

$\overset{2}{\uparrow} \text{R} \overset{2}{\downarrow} \Rightarrow 2.2\mu\text{F}$   
 1-digit effective number.  
 2-digit effective number, decimal point indicated by R.

• Units:  $\mu\text{F}$ .

**\* Capacity (except electrolyte)**

$\overset{2}{\uparrow} \text{2} \overset{2}{\downarrow} \Rightarrow 2200\text{pF} = 0.0022\mu\text{F}$   
 (More than 2) — Indicates number of zeros after effective number.  
 2-digit effective number.

• Units: pF.

$\overset{2}{\uparrow} \text{2} \overset{1}{\downarrow} \Rightarrow 220\text{pF}$   
 (0 or 1) — Indicates number of zeros after effective number.  
 2-digit effective number.

• Units: pF.

• When the dielectric strength is indicated in AC, "AC" is included after the dielectric strength value.

## PARTS LIST OF P.W.B. UNIT ASS'Y 1U-9369A CD P.W.B. UNIT ASS'Y

Ref. No.	Part No.	Part Name	Remarks	Ref. No.	Part No.	Part Name	Remarks
<b>SEMICONDUCTORS GROUP</b>							
IC201	262 2387 002	IC HD6433724E64F		C208	209 0047 903	0.6 jumper wire	
IC203	263 0565 007	IC BA15218		C209,210	254 4254 941	Electrolytic 100μF/16V	CE04W1C101M
IC303,304	262 1409 004	IC PCM61P-L		C212,213	254 4254 941	Electrolytic 100μF/16V	CE04W1C101M
IC371	262 1761 001	IC SM5841BP		C218	253 1181 904	Ceramic 0.01μF/50V	CK45F1H103Z
IC501	263 0693 005	IC M5290P		C219	254 4254 909	Electrolytic 10μF/16V	CE04W1C100M
IC502,503	268 0073 905	IC ICP-N15	IC protector	C220	253 9039 906	BC ceramic cap. 0.1μF/25V	CK45=1E104Z
IC601	499 0295 002	Remocon sensor SBX1910-52		C231	253 9039 906	BC ceramic cap. 0.1μF/25V	CK45=1E104Z
IC701	263 0565 007	IC BA15218		C241	253 9039 906	BC ceramic cap. 0.1μF/25V	CK45=1E104Z
TR201	274 0120 002	Transistor 2SD1762(E/F)		C245	253 1181 904	Ceramic 0.01μF/50V	CK45F1H103Z
TR202	273 0195 908	Transistor 2SC2060(Q)TP		C246	209 0047 903	0.6 jumper wire	
TR203	271 0271 907	Transistor 2SA934(Q)TP		C249	253 1181 904	Ceramic 0.01μF/50V	CK45F1H103Z
TR204,205	269 0020 906	Transistor DTC114ES(10K-10K)		C301	253 1180 921	Ceramic 1000pF/50V	CK45B1H102K
TR301,302	274 0160 907	Transistor 2SD2144STPU		C308,309	254 4254 954	Electrolytic 220μF/16V	CE04W1C221M
TR501	274 0120 002	Transistor 2SD1762(E/F)		C316,316	254 4254 941	Electrolytic 100μF/16V	CE04W1C101M
TR502	272 0083 004	Transistor 2SB1185(E/F)		C317,318	253 1180 921	Ceramic 1000pF/50V	CK45B1H102K
TR503	271 0271 907	Transistor 2SA934(Q)TP		C354	253 1181 904	Ceramic 0.01μF/50V	CK45F1H103Z
TR701	271 0192 905	Transistor 2SA933S(S)		C361	253 1181 904	Ceramic 0.01μF/50V	CK45F1H103Z
TR702	269 0014 909	Transistor DTA124XS(22K-47K)		C372,373	253 4536 909	Ceramic 10pF/50V	CC45SL1H100D
TR703	269 0020 906	Transistor DTC114ES(10K-10K)		C375,376	253 1180 905	Ceramic 680pF/50V	CK45B1H681K
TR705,706	274 0160 907	Transistor 2SD2144STPU		C377,378	253 9031 988	BC ceramic cap. 5600pF/25V	CK45=1E562K
D501-506	276 0553 905	Diode 1SR35-200A		C379	253 9039 906	BC ceramic cap. 0.1μF/25V	CK45=1E104Z
D601-603	276 0616 907	Diode 1SS252		C380	253 1181 904	Ceramic 0.01μF/50V	CK45F1H103Z
D701	276 0616 907	Diode 1SS252		C501	254 4254 792	Electrolytic 2200μF/16V	CE04W1C222MC
ZD202,203	276 0637 902	Zener diode MTZJ6.2A	6.2V	C502	254 4255 717	Electrolytic 4700μF/16V	CE04W1C472MC
ZD201	276 0644 924	Zener diode MTZJ8.2A	8.2V	C503,504	254 4254 941	Electrolytic 100μF/16V	CE04W1C101M
ZD501	276 0644 908	Zener diode MTZJ6.8A	6.8V	C505	254 4260 948	Electrolytic 1μF/50V	CE04W1H010M
ZD502	276 0645 936	Zener diode MTZJ24A	24V	C506	254 4260 964	Electrolytic 3.3μF/50V	CE04W1H3R3M
LD520	393 9420 907	LED SEL4117R		C507	254 4262 946	Electrolytic 47μF/63V	CE04W1J470M
FL601	393 4110 005	FLD FIP8NM6A		C508	254 4261 921	Electrolytic 100μF/50V	CE04W1H101M
<b>RESISTORS GROUP</b>				C509,510	254 4258 934	Electrolytic 33μF/35V	CE04W1V330M
R239,240	209 0047 903	0.6 jumper wire		C512,513	254 4254 941	Electrolytic 100μF/16V	CE04W1C101M
R331,332	209 0047 903	0.6 jumper wire		C514,515	253 1181 904	Ceramic 0.01μF/50V	CK45F1H103Z
R335,336	209 0047 903	0.6 jumper wire		C601	253 1181 904	Ceramic 0.01μF/50V	CK45F1H103Z
R381,382	209 0047 903	0.6 jumper wire		C701,702	253 4537 982	Ceramic 56pF/50V	CC45SL1H560J
R715,716	244 2051 961	Metal oxide 100ohm 1W	RS14B3A101JNBS(S)	C705,706	254 4250 929	Electrolytic 100μF/6.3V	CE04W0J101M
R721,722	209 0047 903	0.6 jumper wire		C708,709	254 4254 941	Electrolytic 100μF/16V	CE04W1C101M
VR301,302	211 6093 970	Semi fixed resistor 100kohm	V06PB104	C711,712	253 1179 961	Ceramic 330pF/50V	CK45B1H331K
VR701	211 0661 010	Variable resistor 2kohm	V0920P30FC202	C723	254 4254 954	Electrolytic 220μF/16V	CE04W1C221M
<b>CAPACITORS GROUP</b>				C791,792	253 4538 949	Ceramic 100pF/50V	CC45SL1H101J
C201-204	253 1181 904	Ceramic 0.01μF/50V	CK45F1H103Z	<b>OTHER PARTS GROUP</b>			
C205	254 4254 954	Electrolytic 220μF/16V	CE04W1C221M	CW041	203 6503 016	4P KR-DA (S) connector cord	1
C206	254 4254 909	Electrolytic 10μF/16V	CE04W1C100M	CW051	203 8280 052	5P KR-DA connector cord	1
C207	253 1181 904	Ceramic 0.01μF/50V	CK45F1H103Z	CW052	203 8424 009	5P connector cord (AMP)	1
				CW081	204 2811 006	8P PH-SAN connector cord	1
				CW091	204 2812 005	9P PH-SAN connector cord	1
				CX041	205 0343 045	4P connector base(KR-PH)	1



1U-9369 CD P.W.B. UNIT ASS'Y

Ref. No.	Part No.	Part Name	Remarks	Q'ty
CX051	205 0343 058	5P connector base(KR-PH)		1
CX081	205 0343 087	8P connector base(KR-PH)		1
CX091	205 0343 090	9 P connector base (KR-PH)		1
CX291	205 0990 045	29P FFC connector base		1
CY231	205 0990 003	23P FFC connector base		1
CY291	205 0990 045	29P FFC connector base		1
EP701	412 4276 004	PWB earth		1
JK201	269 0170 005	TOTX178		1
JK202	204 8416 007	Mini jack		1
JK301	204 8537 009	2P pin jack (GNB) D		1
JK501	203 2349 009	2P inlet		1
JK701	204 8364 023	Head phone jack (gold)		1
S601-605	212 5604 910	Tact switch		5
S608	212 5604 910	Tact switch		1
ST001	205 0452 017	Style pin		1
ST003	205 0452 017	Style pin		1
SW501	212 1039 000	1P Push switch		1
T501	233 9682 003	Power trans. (E2)		1
X201	399 0111 909	Ceramic resonator	CST4.23MGW040-TF01	1
XL371	399 0112 005	Crystal 16.9344 MHz		1

Ref. No.	Part No.	Part Name	Remarks
<b>SEMICONDUCTORS GROUP</b>			
IC201	262 2387 002	IC HD6433724F	
IC203	263 0565 007	IC BA15218	
IC301	262 1869 000	IC SM5845AF	
IC303,304	262 1409 004	IC PCM61P-L	
IC305,306	262 0864 006	IC UPC4570C	
IC351	262 1316 003	IC TC74HC74AP	
IC501	263 0693 005	IC M5290P	
IC502,503	268 0073 905	IC ICP-N15	IC protector
IC601	499 0295 002	Remocon sensor SBX1910-52	
IC701	263 0565 007	IC BA15218	
TR201	274 0120 002	Transistor 2SD1762(E/F)	
TR202	273 0195 908	Transistor 2SC2060(Q)TP	
TR203	271 0271 907	Transistor 2SA934(Q)TP	
TR204,205	269 0020 906	Transistor DTC114ES(10K-10K)	
TR301,302	274 0160 907	Transistor 2SD2144STPU	
TR351	269 0089 905	Transistor RN2205	
TR501	274 0120 002	Transistor 2SD1762(E/F)	
TR502	272 0083 004	Transistor 2SB1185(E/F)	
TR503	271 0271 907	Transistor 2SA934(Q)TP	
TR701	271 0192 905	Transistor 2SA933S(S)	
TR702	269 0014 909	Transistor DTA124XS (22K-47K)	
TR703	269 0020 906	Transistor DTC114ES(10K-10K)	
TR705,706	274 0160 907	Transistor 2SD2144STPU	
D351,352	276 0616 907	Diode 1SS252	
D501-506	276 0553 905	Diode 1SR35-200A	
D601-603	276 0616 907	Diode 1SS252	
D701	276 0616 907	Diode 1SS252	
ZD202,203	276 0637 902	Zener diode MTZJ6.2A	6.2V
ZD201	276 0644 924	Zener diode MTZJ8.2A	8.2V
ZD501	276 0644 908	Zener diode MTZJ6.8A	6.8V
ZD502	276 0645 936	Zener diode MTZJ24A	24V
LD520	393 9420 907	LED SEL4117R	
FL601	393 4110 005	FLD FIP8NM6A	

Ref. No.	Part No.	Part Name	Remarks
<b>RESISTORS GROUP</b>			
R239	209 0047 903	0.6 jumper wire	
R240	209 0047 903	0.6 jumper wire	
R315,316	209 0047 903	0.6 jumper wire	
R715,716	244 2051 961	Metal oxide 100ohm 1W	S14B3A101JNBS(S)
R721,722	209 0047 903	0.6 jumper wire	
VR301,302	211 6093 970	Semi fixed resistor 100kohm	V06PB104
VR701	211 0661 010	Variable resistor 2kohm	V0920P30FC202
<b>CAPACITORS GROUP</b>			
C201-204	253 1181 904	Ceramic 0.01μF/50V	CK45F1H103Z
C205	254 4254 954	Electrolytic 220μF/16V	CE04W1C221M
C206	254 4254 909	Electrolytic 10μF/16V	CE04W1C100M
C207	253 1181 904	Ceramic 0.01μF/50V	CK45F1H103Z
C208	209 0047 903	0.6 jumper wire	
C209,210	254 4254 941	Electrolytic 100μF/16V	CE04W1C101M
C212,213	254 4254 941	Electrolytic 100μF/16V	CE04W1C101M
C218	253 1181 904	Ceramic 0.01μF/50V	CK45F1H103Z
C219	254 4254 909	Electrolytic 10μF/16V	CE04W1C100M
C220	253 9039 906	BC ceramic cap. 0.1μF/25V	CK45=1E104Z
C231	253 9039 906	BC ceramic cap. 0.1μF/25V	CK45=1E104Z
C241	253 9039 906	BC ceramic cap. 0.1μF/25V	CK45=1E104Z
C245	253 1180 921	Ceramic 1000pF/50V	CK45B1H102K
C246	209 0047 903	0.6 jumper wire	
C249	253 1181 904	Ceramic 0.01μF/50V	CK45F1H103Z
C301	253 1180 921	Ceramic 1000pF/50V	CK45B1H102K
C302,303	253 4536 909	Ceramic 10pF/50V	CC45SL1H100D
C304	253 1181 904	Ceramic 0.01μF/50V	CK45F1H103Z
C305	253 9039 906	BC ceramic cap. 0.1μF/25V	CK45=1E104Z
C308,309	254 4254 954	Electrolytic 220μF/16V	CE04W1C221M
C315,316	254 4313 950	Electrolytic 100μF/50V	CE04W1H101M
C317,318	255 4232 937	Polypropylene film 1000pF/100V	CQ93P2A102J
C331,332	255 4232 908	Polypropylene film 820pF/100V	CQ93P2A821J
C333,334	255 4232 911	Polypropylene film 180pF/100V	CQ93P2A181J
C335,336	255 4232 937	Polypropylene film 1000pF/100V	CQ93P2A102J
C337,338	255 4232 979	Polypropylene film 200pF/100V	CQ93P2A201J
C351	253 4537 966	Ceramic 47pF/50V	CC45SL1H470J
C352	253 1180 947	Ceramic 1500pF/50V	CK45B1H152K
C353	254 4260 948	Electrolytic 1μF/50V	CE04W1H010M
C354	253 1180 921	Ceramic 1000pF/50V	CK45B1H102K
C355	253 9039 906	BC ceramic cap. 0.1μF/25V	CK45=1E104Z
C361	253 1181 904	Ceramic 0.01μF/50V	CK45F1H103Z
C501	254 4254 792	Electrolytic 2200μF/16V	CE04W1C222MC
C502	254 4255 717	Electrolytic 4700μF/16V	CE04W1C472MC
C503,504	254 4254 941	Electrolytic 100μF/16V	CE04W1C101M
C505	254 4260 948	Electrolytic 1μF/50V	CE04W1H010M
C506	254 4260 964	Electrolytic 3.3μF/50V	CE04W1H3R3M
C507	254 4262 946	Electrolytic 47μF/63V	CE04W1J470M
C508	254 4261 921	Electrolytic 100μF/50V	CE04W1H101M

Ref. No.	Part No.	Part Name	Remarks	Q'ty
C509,510	254 4258 934	Electrolytic 33mF/35V	CE04W1V330M	
C512,513	254 4254 941	Electrolytic 100mF/16V	CE04W1C101M	
C514,515	253 1181 904	Ceramic 0.01μF/50V	CK45F1H103Z	
C601	253 1181 904	Ceramic 0.01μF/50V	CK45F1H103Z	
C701,702	253 4537 982	Ceramic 56pF/50V	CC45SL1H560J	
C705,706	254 4250 929	Electrolytic 100μF/6.3V	CE04W0J101M	
C708,709	254 4254 941	Electrolytic 100μF/16V	CE04W1C101M	
C711,712	253 1179 961	Ceramic 330pF/50V	CK45B1H331K	
C723	254 4254 954	Electrolytic 220μF/16V	CE04W1C221M	
C791,792	253 4538 949	Ceramic 100pF/50V	CC45SL1H101J	
C793	253 1180 921	Ceramic 1000pF/50V	CK45B1H102K	
<b>OTHER PARTS GROUP</b>				
CW041	203 6503 016	4P KR-DA (S) connector cord		1
CW051	203 8280 052	5P KR-DA connector cord		1
CW052	203 8424 009	5P connector cord (AMP)		1
CW081	204 2811 006	8P PH-SAN connector cord		1
CW091	204 2812 005	9P PH-SAN connector cord		1
CX041	205 0343 045	4P connector base(KR-PH)		1
CX051	205 0343 058	5P connector base(KR-PH)		1
CX081	205 0343 087	8P connector base(KR-PH)		1
CX091	205 0343 090	9 P connector base (KR-PH)		1
CX291	205 0990 045	29P FFC connector base		1
CY231	205 0990 003	23P FFC connector base		1
CY291	205 0990 045	29P FFC connector base		1
EP701	412 4276 004	PWB earth		1
JK201	269 0170 005	TOTX178		1
JK202	204 8416 007	Mini jack		1
JK301	204 8537 009	2P pin jack (GNB) D		1
JK501	203 2349 009	2P inlet		1
JK701	204 8364 023	Head phone jack (gold)		1
S601-605	212 5604 910	Tact switch		5
S608	212 5604 910	Tact switch		1
ST001	205 0452 017	Style pin		1
ST003	205 0452 017	Style pin		1
SW501	212 1039 000	1P Push switch		1
T501	233 9682 003	Power trans. (E2)		1
X201	399 0111 909	Ceramic resonator	CST4.23MGW040-TF01	1
X301	399 0112 005	Crystal 16.9344 MHz		1

# PRINTED WIRING BOARD

1 2 3 4 5 6 7 8

## CD MECHANISM UNIT SA4-6735-09A P.W.B.ASS'Y

**[BD BOARD] (SIDE A)**

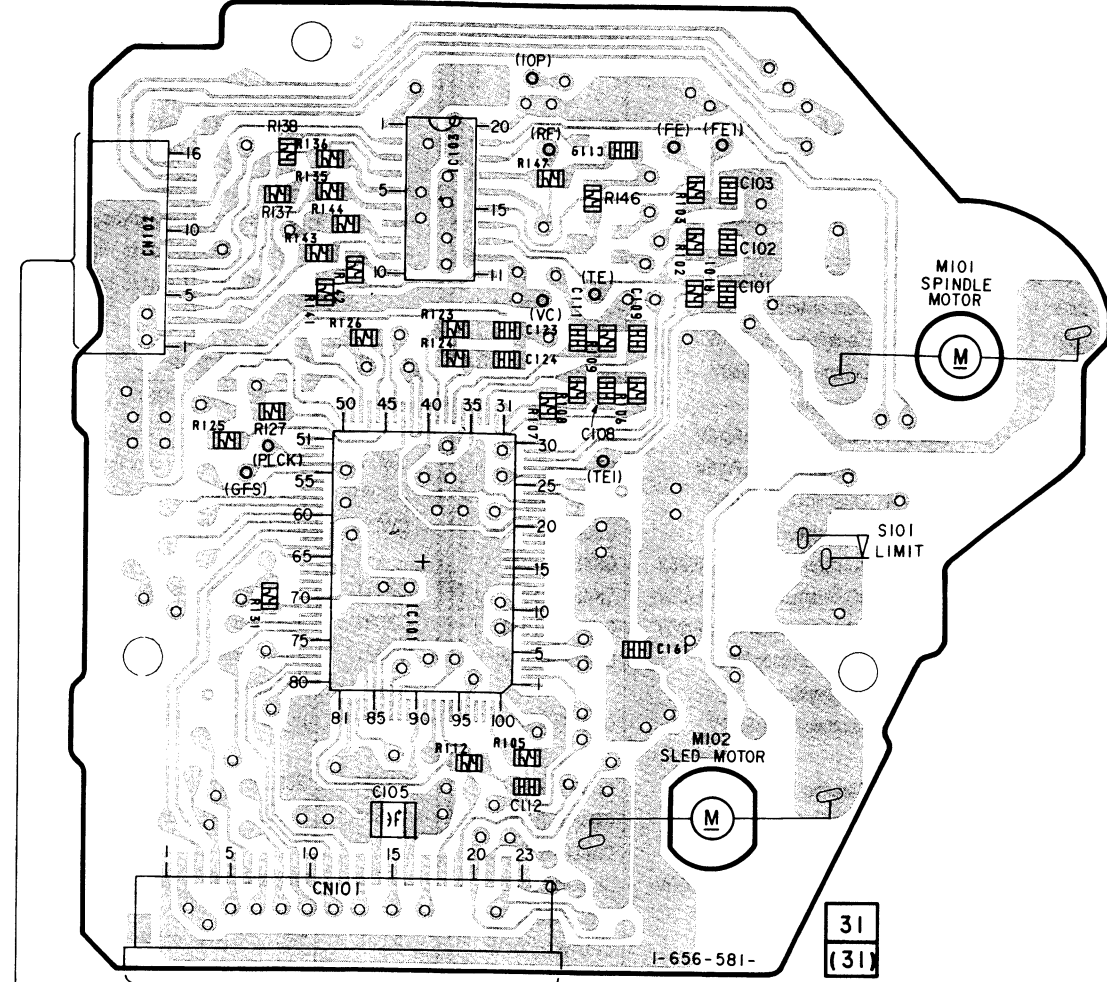

**[BD BOARD] (SIDE B)**

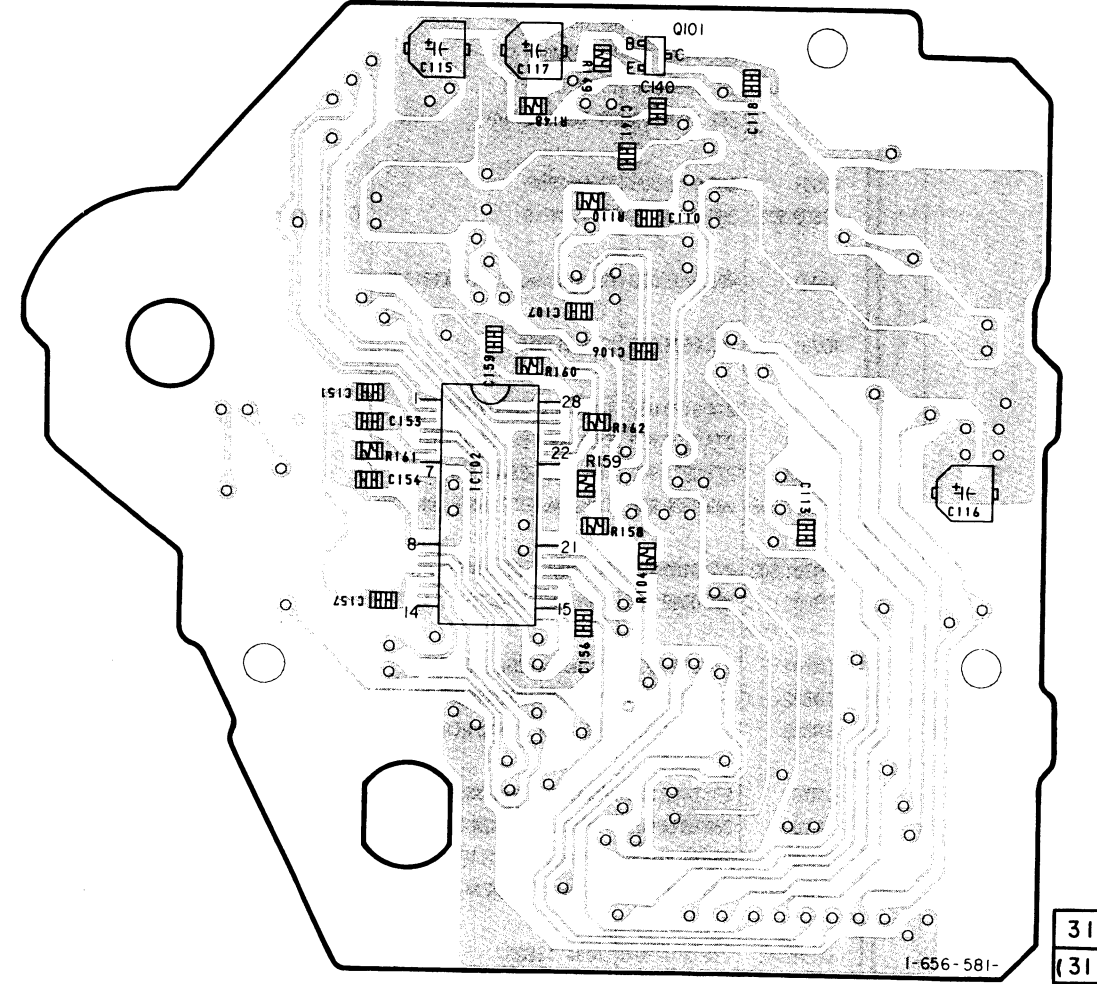

**A** MAIN BOARD  
CN201

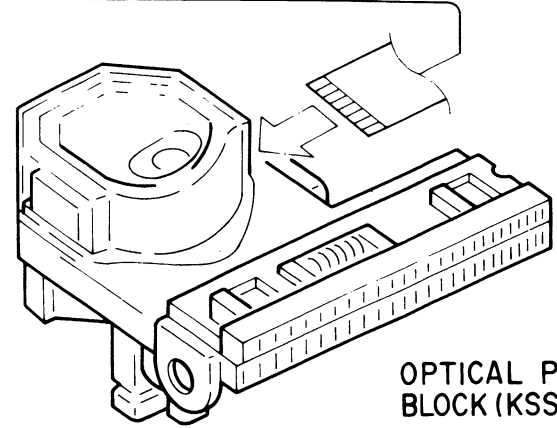

**OPTICAL PICK-UP  
BLOCK (KSS-213BA/F-NP)**

**S16 4572 111 LOADING P.W.B.ASS'Y**

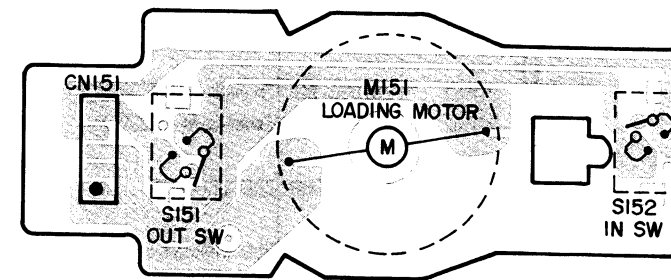

1 2 3 4 5 6 7 8

1U-9369A CD P.W.B. UNIT

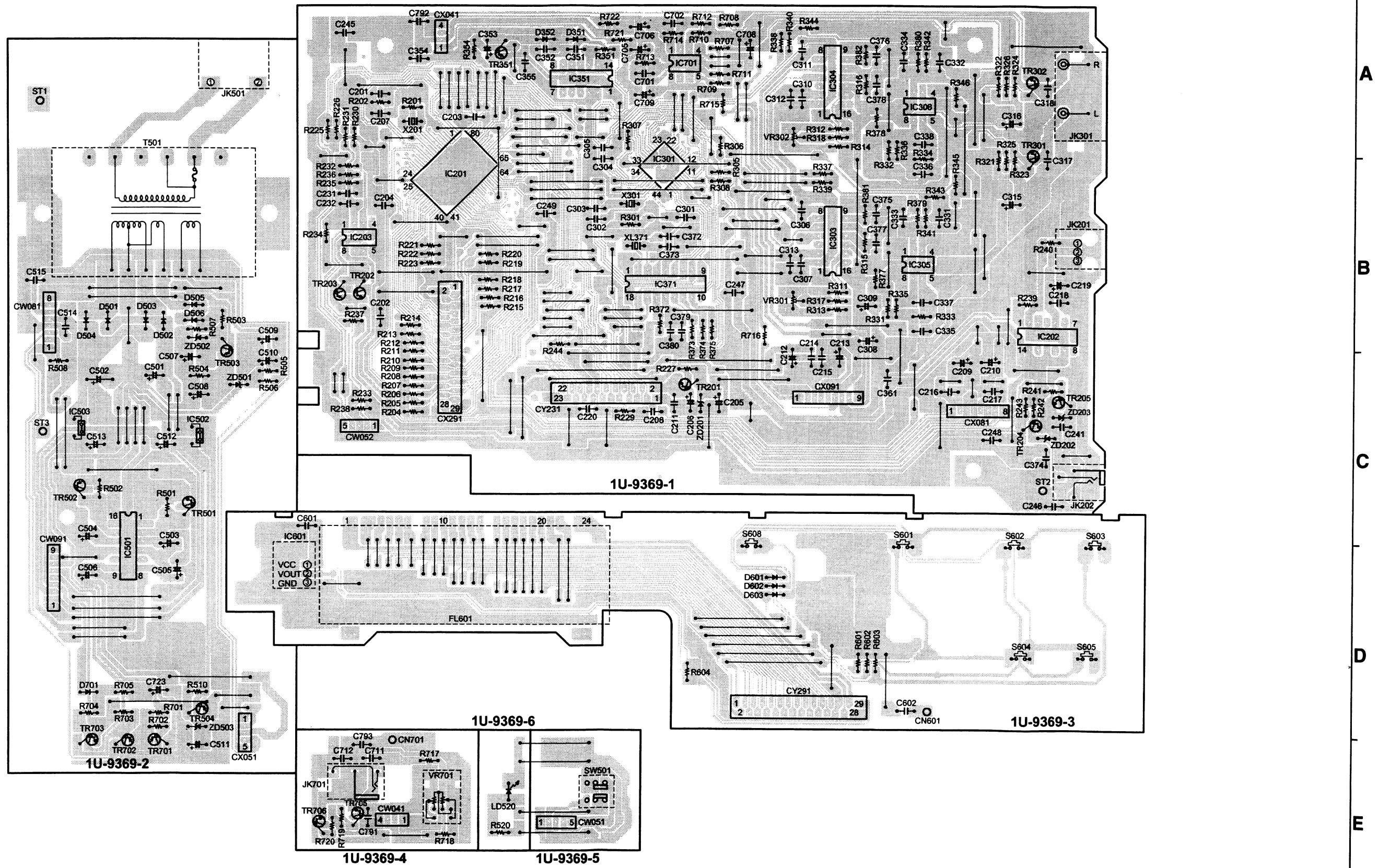

# EXPLODED VIEW OF CHASSIS AND CABINET

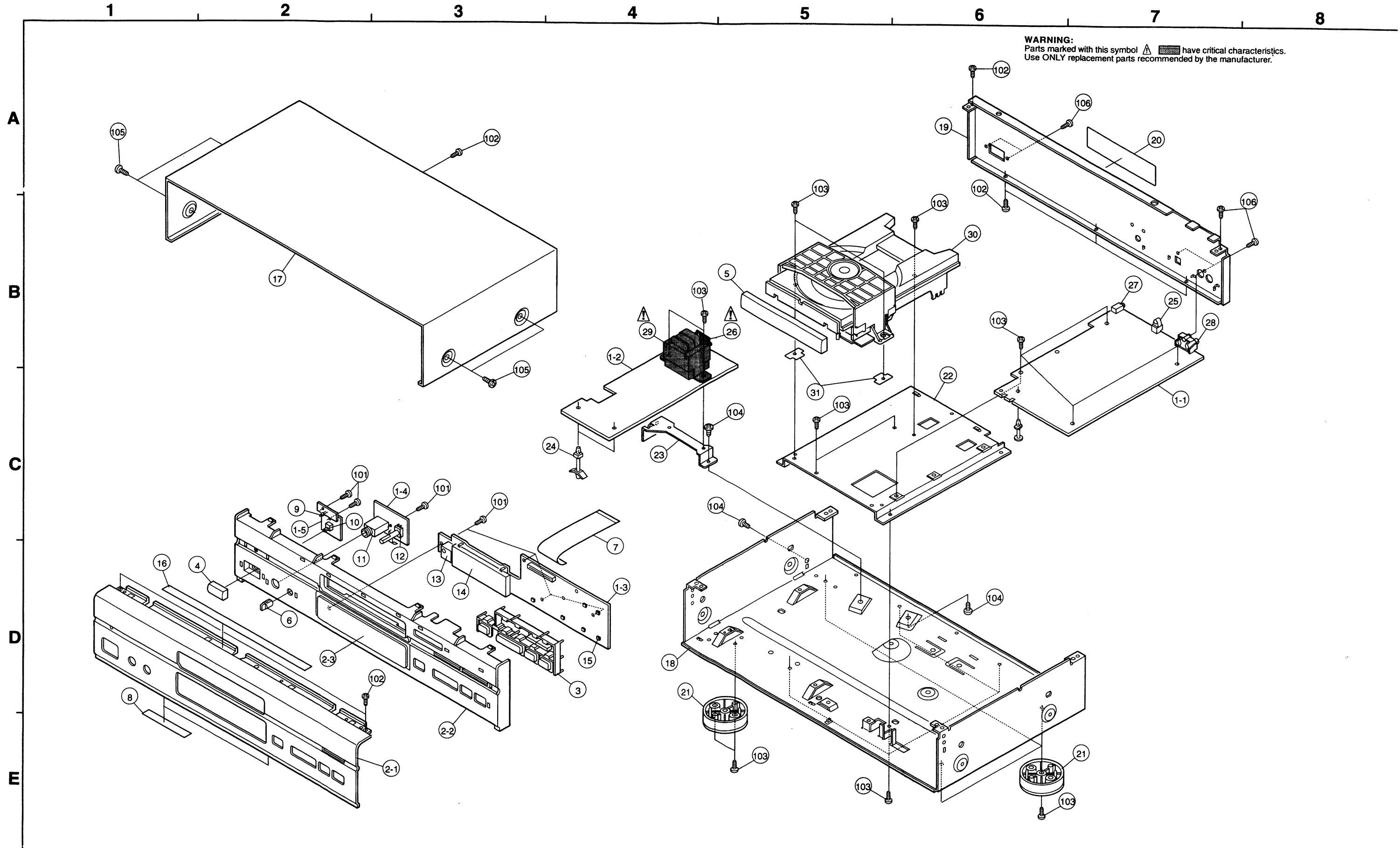



**PARTS LIST EXPLODED VIEW**

Ref. No.	Part No.	Part Name	Remarks	Q'ty
●	1	1U-9369	CD P.W.B. unit ass'y	DCD735 1
●	1	1U-9369 A	CD P.W.B. unit ass'y	DCD635 1
	-1-1	—	Main P.W.B. unit	
	1-2	—	Power P.W.B. unit	
	1-3	—	Display P.W.B. unit	
	1-4	—	H/P Jack P.W.B. unit	
	1-5	—	Power switch P.W.B. unit	
●	2	144 2535 200	Front panel Ass'y	DCD735 Black 1
●	2	144 2535 213	Front panel Ass'y	DCD735 Gold 1
●	2	144 2535 226	Front panel Ass'y	DCD635 Black 1
●	2	144 2535 239	Front panel Ass'y	DCD635 Gold 1
	-2-1	—	Front panel	
	-2-2	—	Inner panel	
	-2-3	—	Window	
	3	113 1818 005	Function knob	Black model 1
	3	113 1818 018	Function knob	Gold model 1
	4	113 1689 001	Power switch knob	Black model 1
	4	113 1689 014	Power switch knob	Gold model 1
●	5	146 1685 005	Loader panel	Black model 1
●	5	146 1685 018	Loader panel	Gold model 1
	6	112 0645 111	Headphone knob	Black model 1
	6	112 0645 124	Headphone knob	Gold model 1
	7	009 0109 018	29P FFC	L=125 1
	8	122 9030 009	Himeron sheet	2
	9	393 9420 907	LED (SEL4117R-T)	LD520 1
	10	212 1039 000	1P push switch	SW501 1
	11	204 8364 023	Headphone jack (Gold)	JK701 1
	12	211 0661 010	Variable resistor 2kohm	VR701 1
	13	499 0295 002	Remote sensor (SBX1910-52)	IC601 1
	14	393 4110 005	FL tube (FIP8NM6A)	FL601 1
	15	212 5604 910	Tact switch	S601-606 6
	16	122 0187 100	Top cover spacer	1
●	17	102 0424 005	:Top cover	Black model 1
●	17	102 0424 018	:Top cover	Gold model 1
●	18	411 1233 319	Chassis	1
●	19	105 1232 004	Back panel	DCD735 1
●	19	105 1232 017	Back panel	DCD635 1
	20	513 2358 007	E2 laser caution	1
	21	104 0260 100	Foot ass'y	4
	22	412 4222 100	Mecha holder	1
	23	412 4223 002	Trans bracket	1
	24	415 9016 048	P.C.B. holder	2
	25	269 0170 005	Optical link (TOTX178)	JK201 1
▲	26	203 2349 009	2P inlet	JK501 1
	27	204 8416 007	Mini jack	JK202 1
	28	204 8537 009	2P pin jack	JK301 1
▲	29	233 0682 003	Power transformer (E2)	T-501 1
	30	337 0047 004	CD Mech. (CDM14-5BD20)	1
	31	461 0971 004	Spacer	2

Ref. No.	Part No.	Part Name	Remarks	Q'ty
<b>SCREWS</b>				
	101	473 7508 017	Screw 3x10 (P) Black	5
	102	473 7015 005	Screw 3X6 (S) Black	8
	103	473 7002 018	Screw 3X8 (S)	22
	104	473 0040 016	Screw 4X6 (S)	3
	105	473 7007 000	Screw 4X8 (S) Black	Black model 4
	105	—	Screw 4x8 CTTS	Gold model 4
	106	477 0064 107	Fixing screw 3x10	4
<b>PACKING &amp; ACCESSORIES</b>				
		203 2310 009	2P pin cord	1
▲		206 2108 003	:AC cord with plug	E2 mdel only 1
▲		206 2113 001	:AC cord with connector (EK)	EK mdel only 1
		399 0360 006	Remote control unit (RC-266)	With batteries 1
		501 1956 009	Carton case	DCD735 E2 1
		501 1956 012	Carton case	DCD635 E2 1
		501 1975 006	Carton case	DCD635 EK 1
		503 9223 015	Cushion	E2 mdel 2
		503 1173 008	Cushion	EK mdel 2
		503 1264 001	Cushion sheet	1
		505 0131 050	Cabinet cover	EK mdel only 1
		505 0283 018	Poly. cover	1
		511 3089 007	Inst. manual	1
		513 1349 004	Thermal carbon film	1
		513 1389 006	Control card base	1
		513 9111 001	Color label (gold)	Gold model only 2

EXPLODED VIEW OF CD MECHANISM UNIT

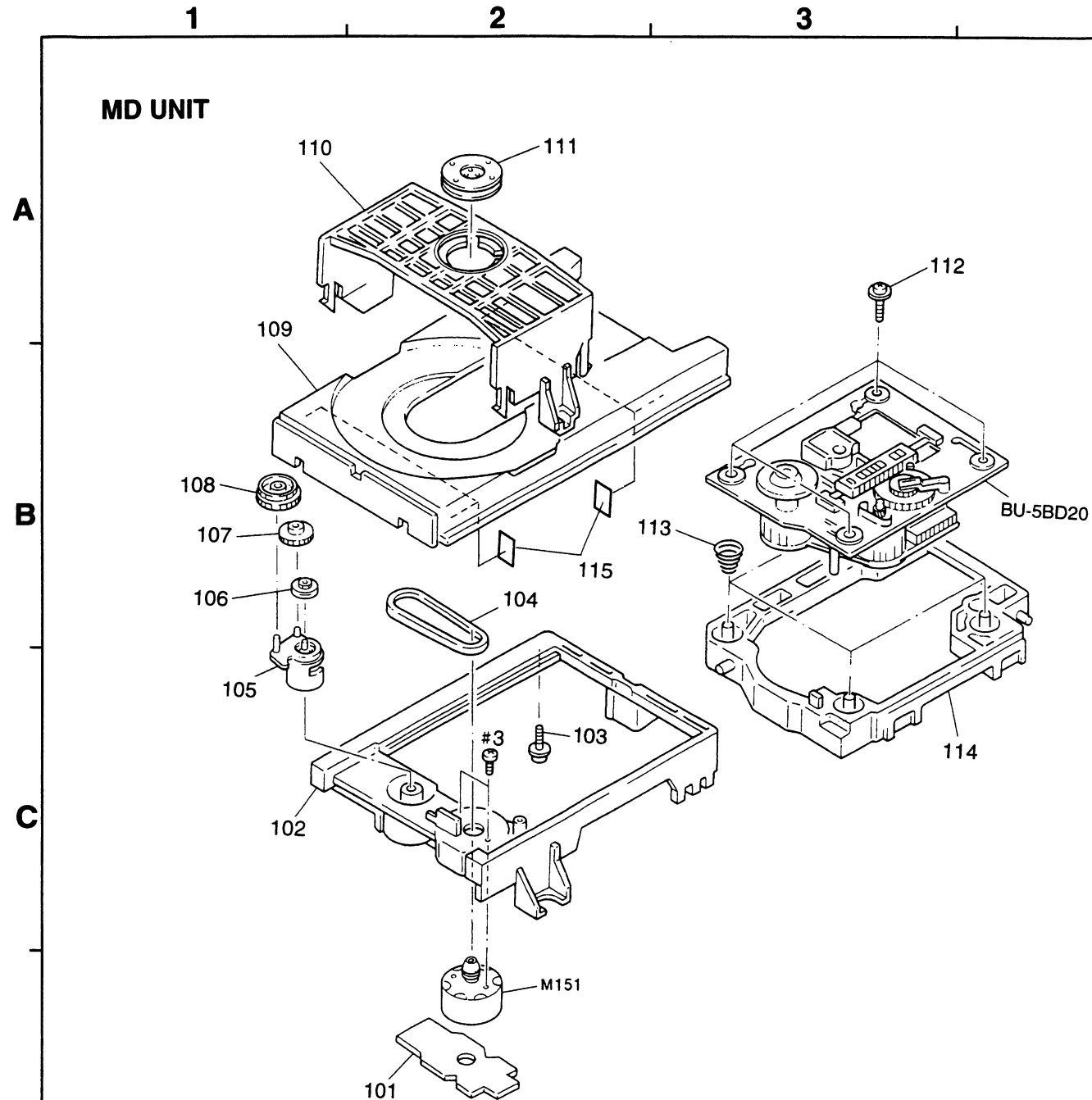

OPTICAL PICK-UP UNIT

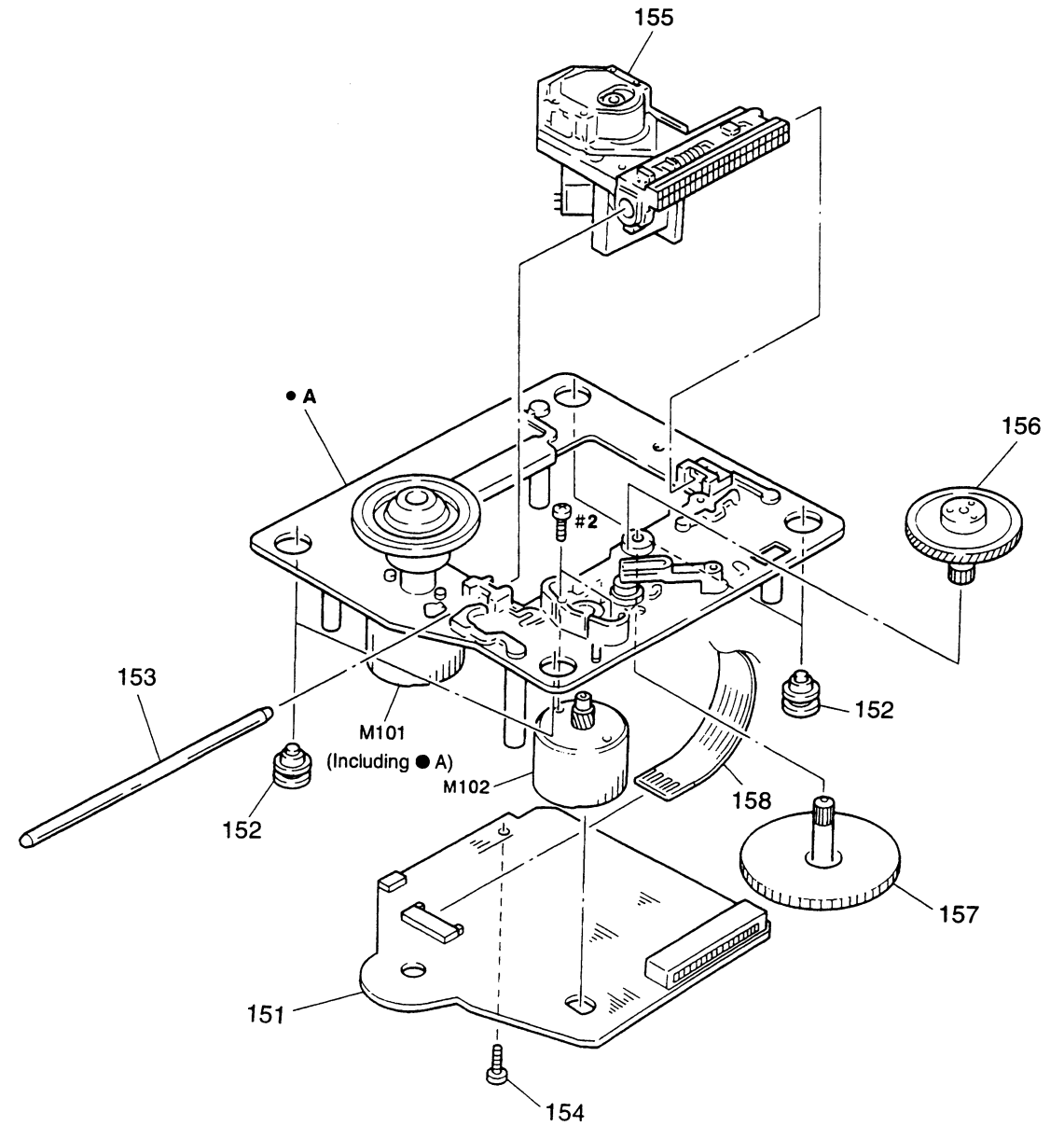

PARTS LIST OF CD MECHANISM UNIT

Ref. No.	Part No.	Part Name	Remarks	Ref. No.	Part No.	Part Name	Remarks
51	S16 4572 111	Loading P.W.B. Ass'y	See Page 26	60	S49 3311 001	Holder (MG)	
52	S49 3311 101	Chassis (MD)		61	SA4 6606 52A	Magnet	
53	S49 1758 321	Yoke Bracket		62	S49 3313 401	Screw	
54	S49 2764 901	Belt		63	S49 5999 601	Spring (932)	
55	S49 3310 901	Cam		64	S49 3312 932	Holder (BU)	
56	S49 2765 101	Pulley (S)		65	S49 2531 531	Damper	
57	S49 6726 801	Gear (C)		M151	SA4 6606 92A	Motor (L) Ass'y	
58	S49 3310 701	Gear (PL)		#1	471 3201 024	Screw 2.6x4	
59	S49 3311 201	Disc Table					

PARTS LIST OF OPTICAL PICK-UP UNIT

Ref. No.	Part No.	Part Name	Remarks	Ref. No.	Part No.	Part Name	Remarks
101	SA4 6735 09A	P.W.B. Ass'y	See Page 26	108	S17 6906 911	Flat Cable	
102	S49 5194 001	Insulator Rubber		M101	SX4 9175 233	Motor (Spindle) Ass'y	
103	S49 1756 501	Sled shaft		M102	SX4 9175 041	Motor (Sled) Ass'y	
105	S88 4837 831	Optical PU KSS213BA/F-NP		109	S49 5162 001	Screw	
106	S49 1756 721	Gear (M)		#2	471 1810 019	Screw 2x3	
107	S49 1756 401	Gear (P)					

WIRING DIAGRAM

1 2 3 4 5 6 7 8

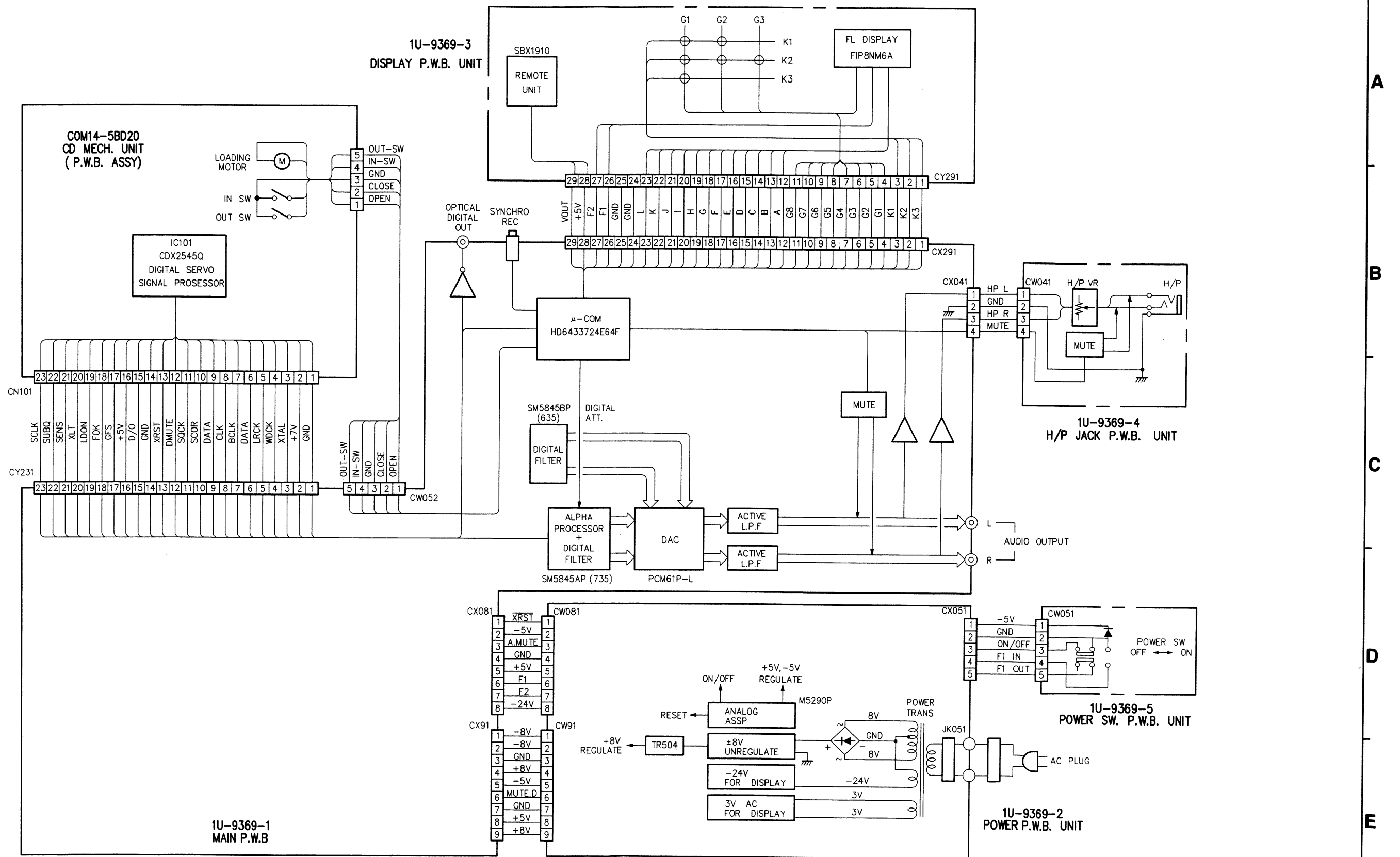

SCHEMATIC DIAGRAM (1/3)

1 2 3 4 5 6 7 8

A

B

C

D

E

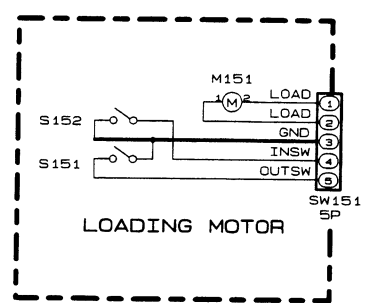
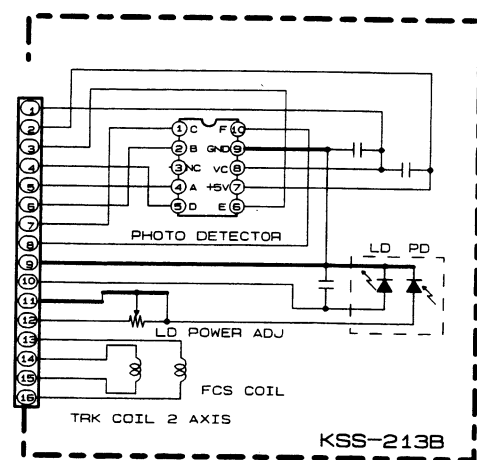
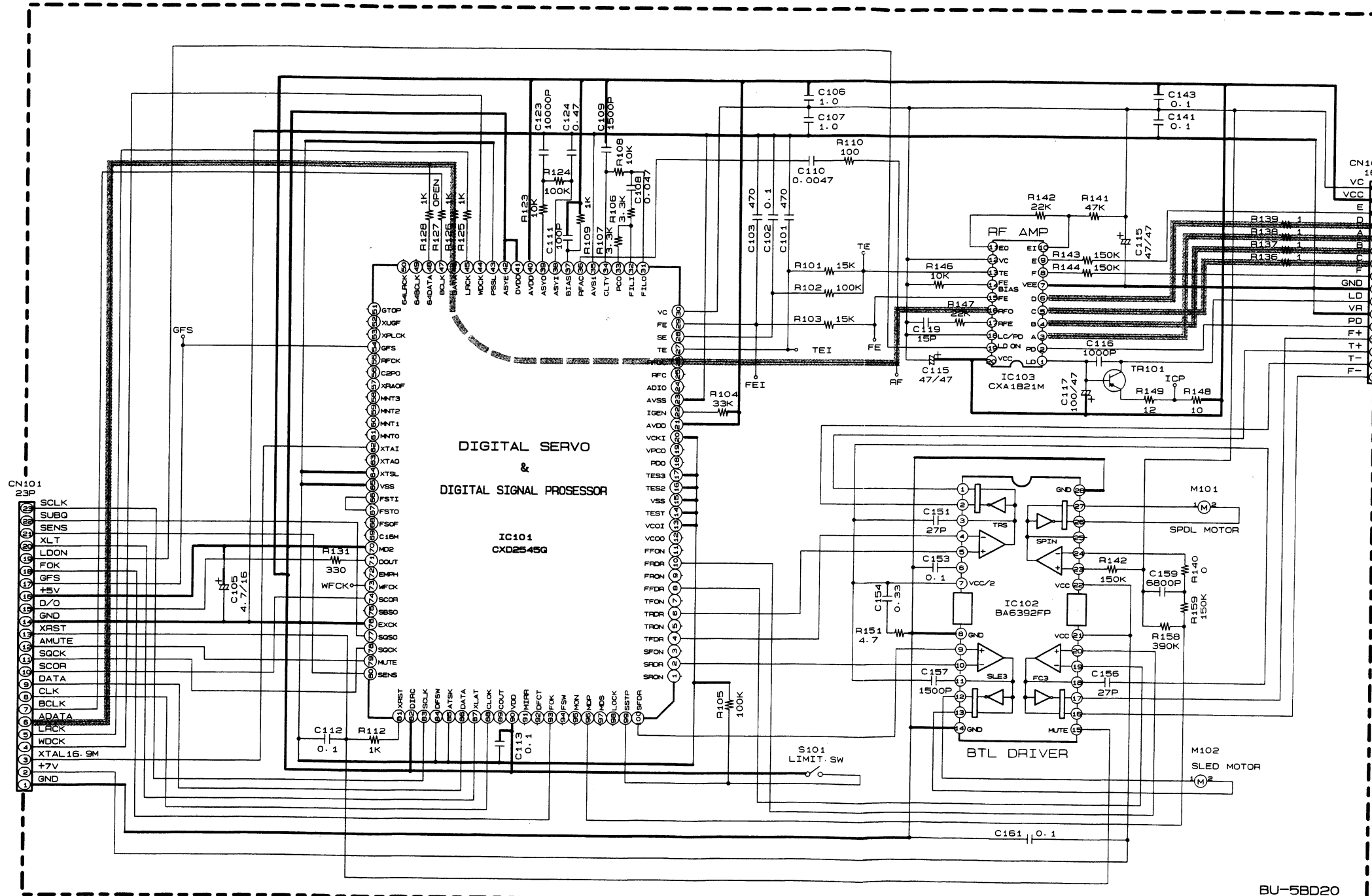

BU-5BD20



**SCHEMATIC DIAGRAM (3/3)**

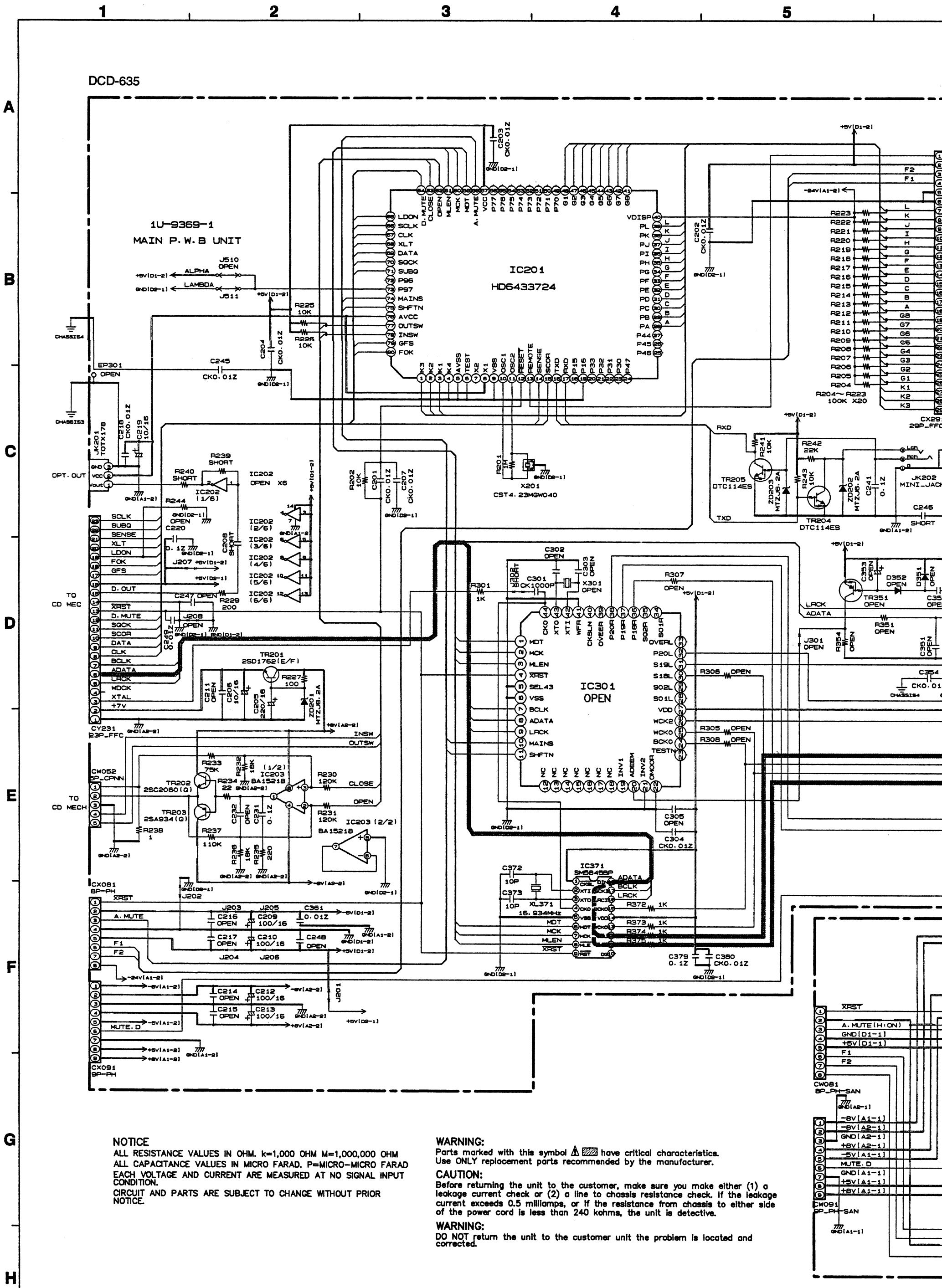

**NOTICE**  
 ALL RESISTANCE VALUES IN OHM. k=1,000 OHM M=1,000,000 OHM  
 ALL CAPACITANCE VALUES IN MICRO FARAD. P=MICRO-MICRO FARAD  
 EACH VOLTAGE AND CURRENT ARE MEASURED AT NO SIGNAL INPUT  
 CONDITION.  
 CIRCUIT AND PARTS ARE SUBJECT TO CHANGE WITHOUT PRIOR  
 NOTICE.

**WARNING:**  
 Parts marked with this symbol have critical characteristics.  
 Use ONLY replacement parts recommended by the manufacturer.

**CAUTION:**  
 Before returning the unit to the customer, make sure you make either (1) a leakage current check or (2) a line to chassis resistance check. If the leakage current exceeds 0.5 millamps, or if the resistance from chassis to either side of the power cord is less than 240 kohms, the unit is defective.

**WARNING:**  
 DO NOT return the unit to the customer unit the problem is located and corrected.

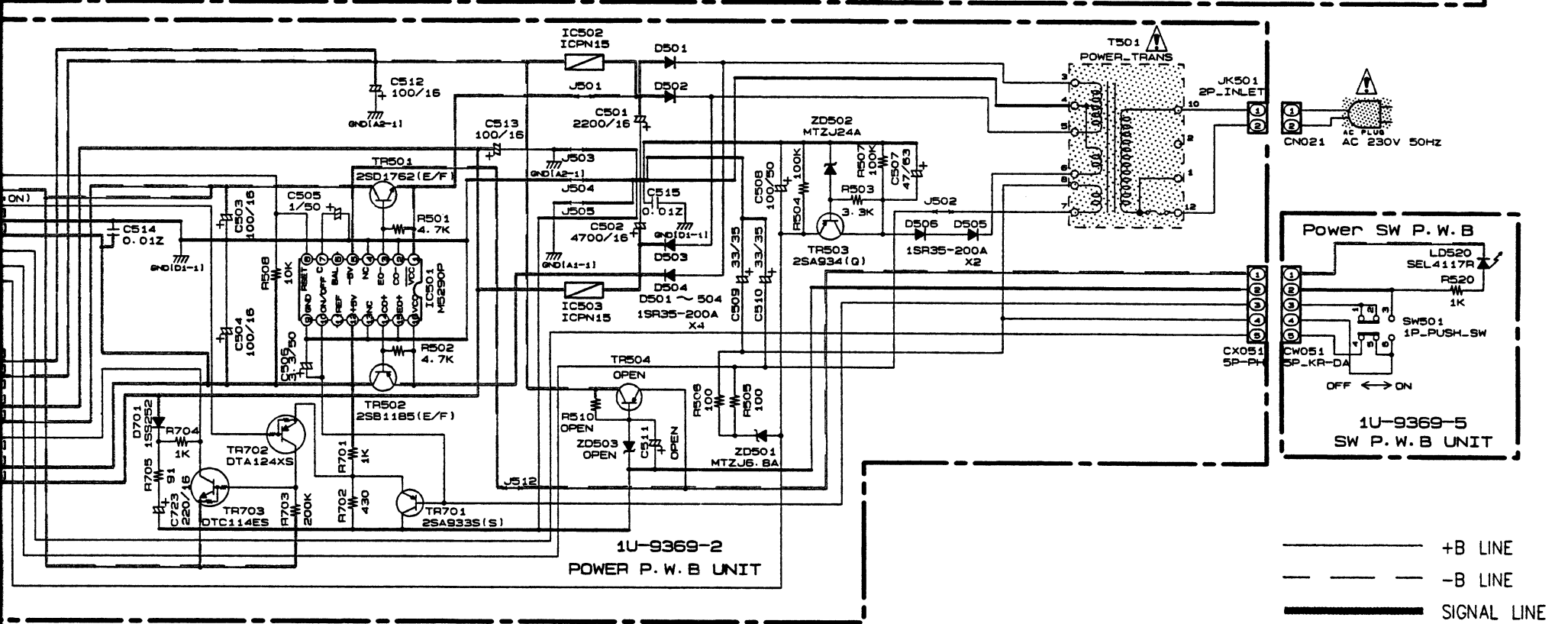
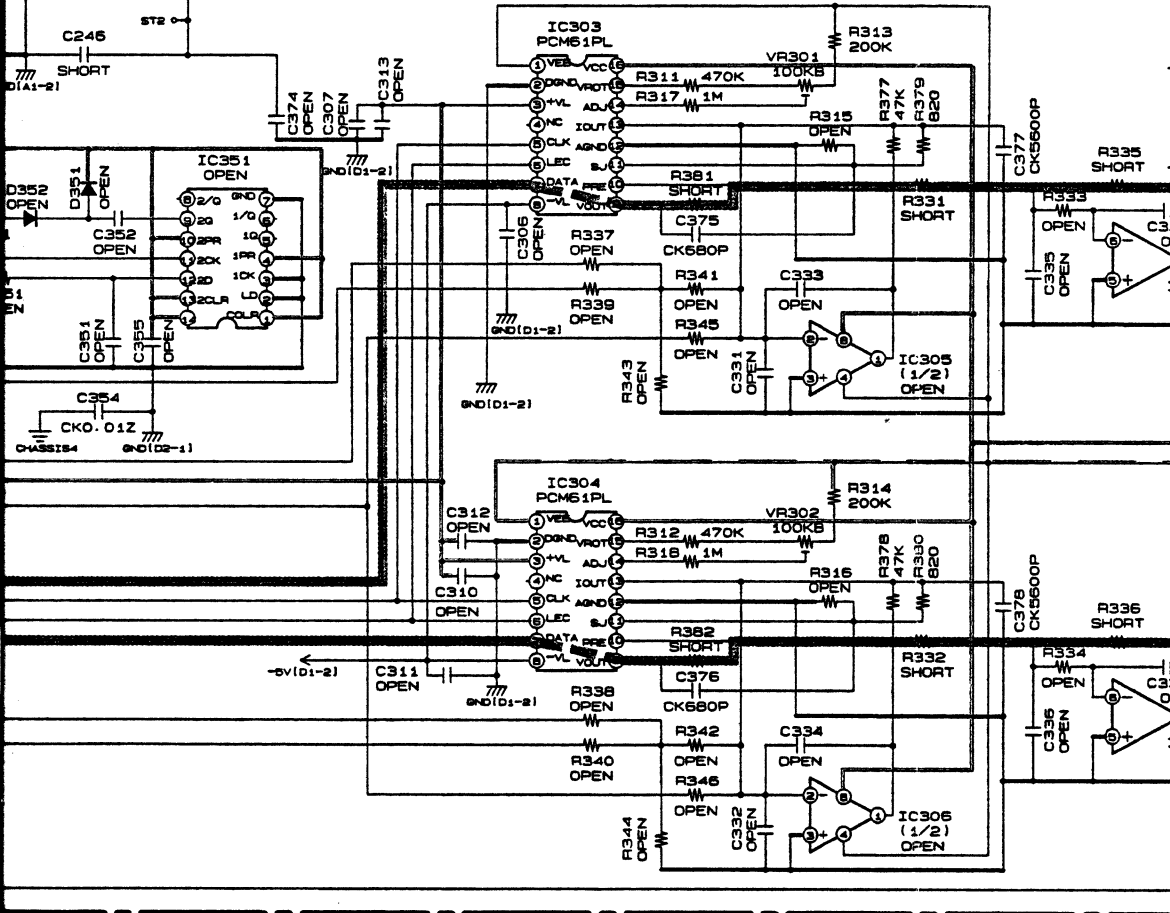
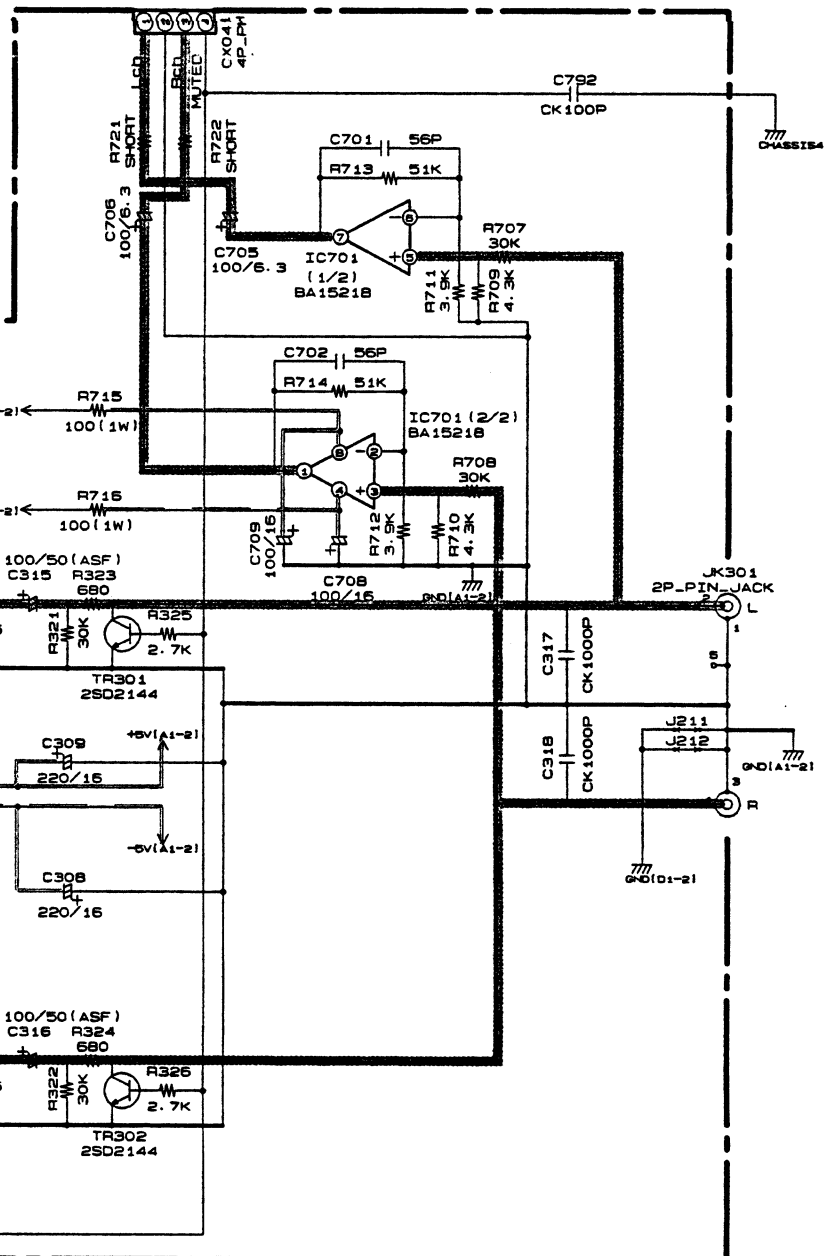
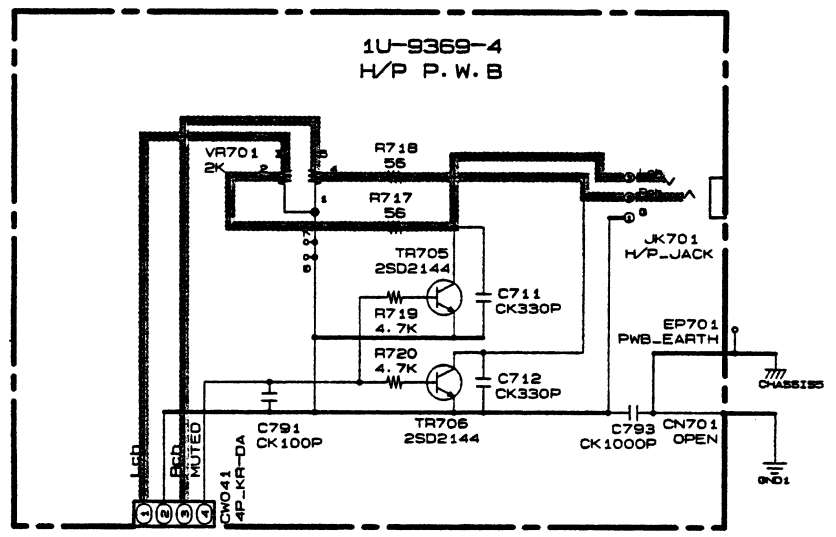
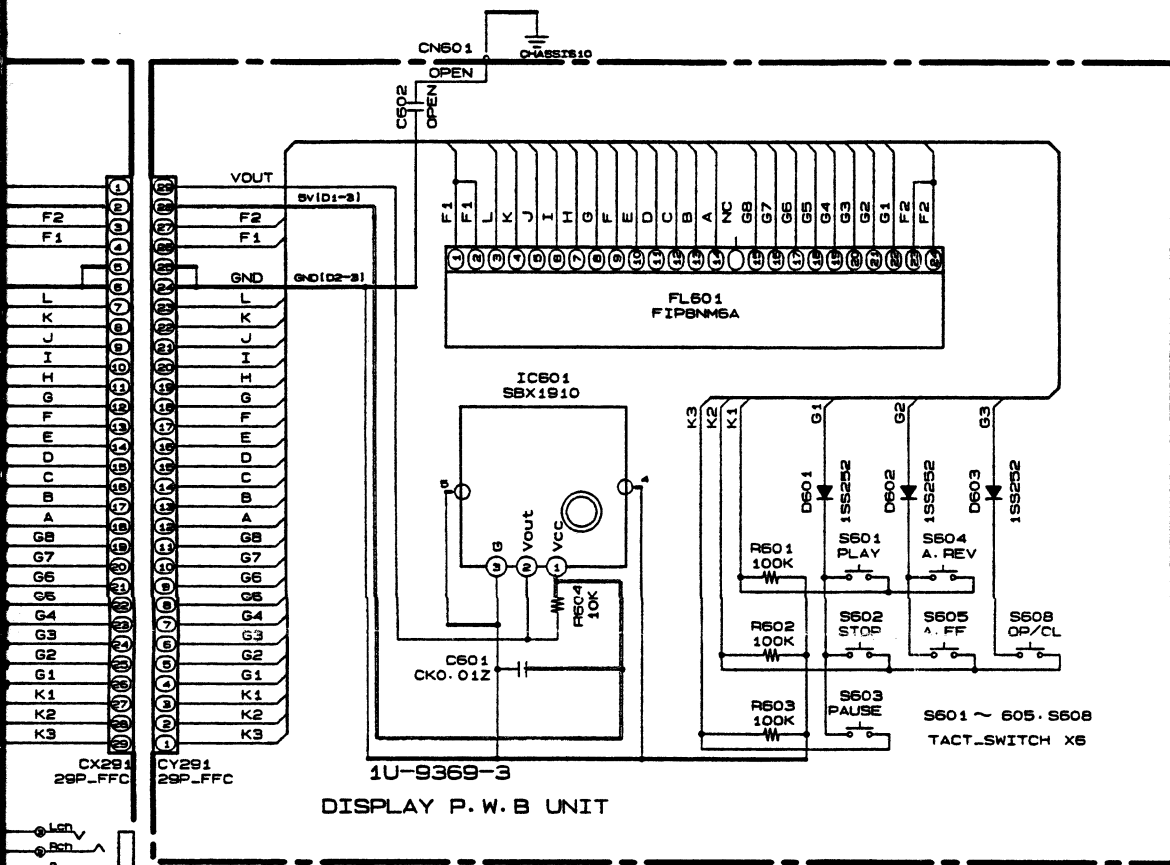

— +B LINE  
 - - - -B LINE  
 ——— SIGNAL LINE

**SCHEMATIC DIAGRAM (2/3)**

1 2 3 4 5 6

DCD-735

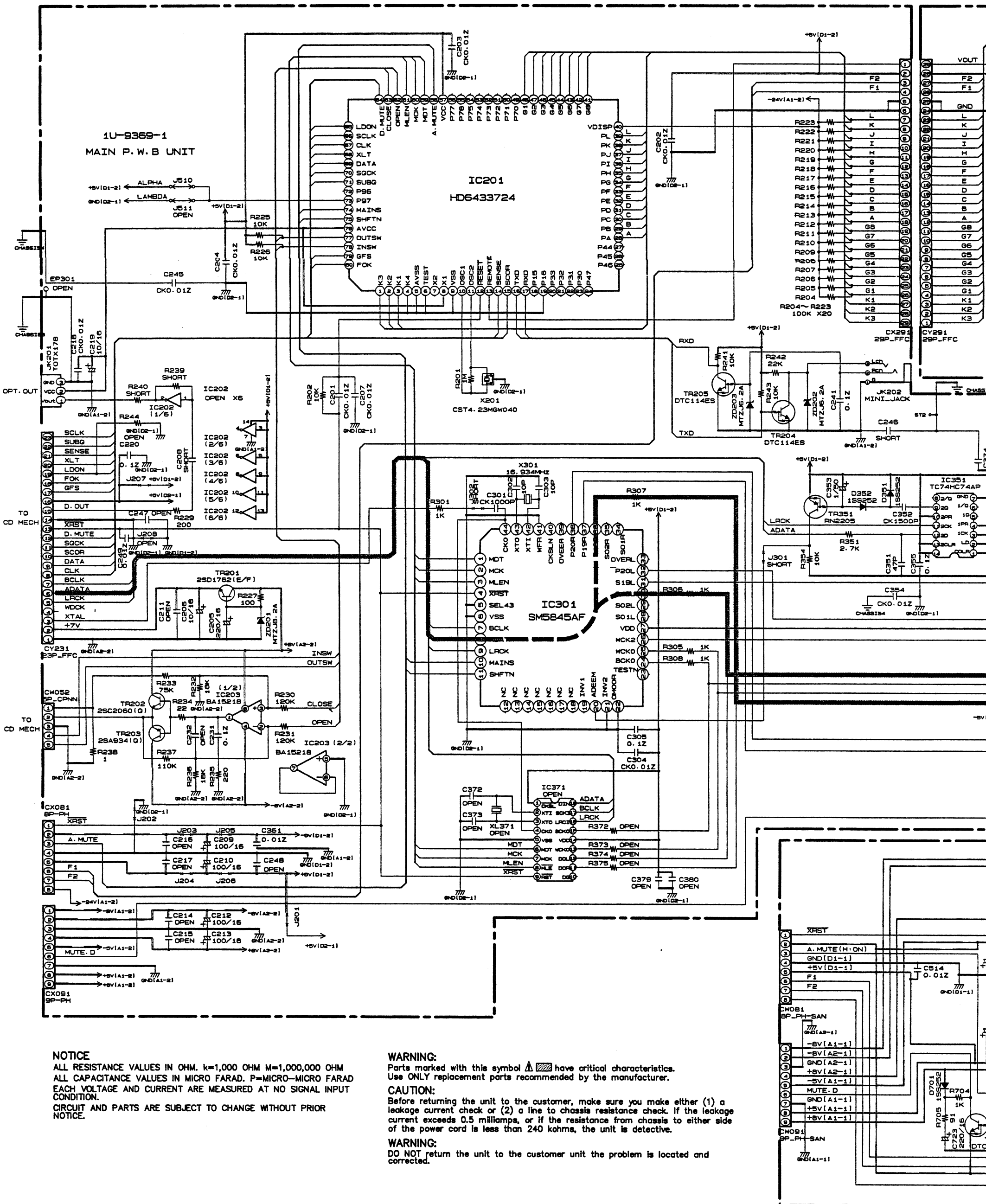

**NOTICE**  
 ALL RESISTANCE VALUES IN OHM. k=1,000 OHM M=1,000,000 OHM  
 ALL CAPACITANCE VALUES IN MICRO FARAD. P=MICRO-MICRO FARAD  
 EACH VOLTAGE AND CURRENT ARE MEASURED AT NO SIGNAL INPUT  
 CONDITION.  
 CIRCUIT AND PARTS ARE SUBJECT TO CHANGE WITHOUT PRIOR  
 NOTICE.

**WARNING:**  
 Parts marked with this symbol have critical characteristics.  
 Use ONLY replacement parts recommended by the manufacturer.

**CAUTION:**  
 Before returning the unit to the customer, make sure you make either (1) a  
 leakage current check or (2) a chassis resistance check. If the leakage  
 current exceeds 0.5 millamps, or if the resistance from chassis to either side  
 of the power cord is less than 240 kohms, the unit is defective.

**WARNING:**  
 DO NOT return the unit to the customer unit the problem is located and  
 corrected.

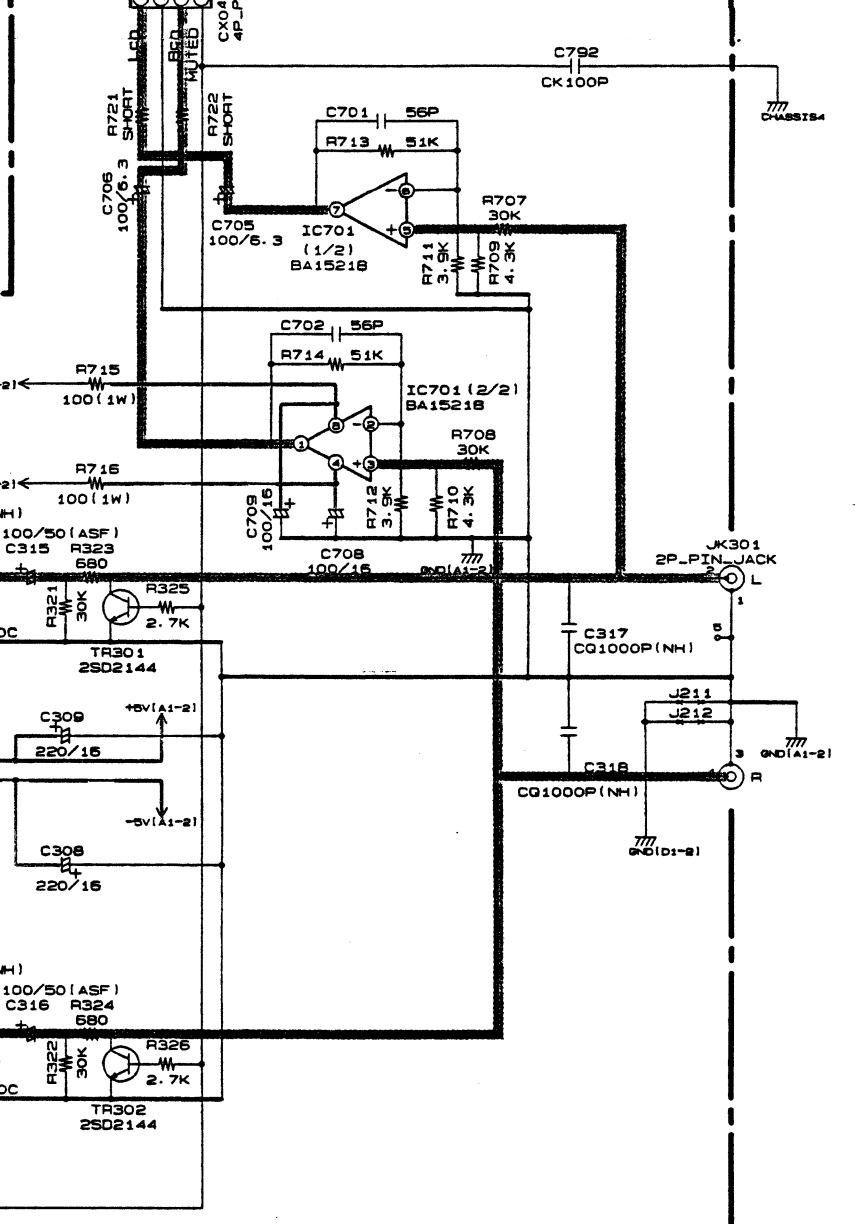
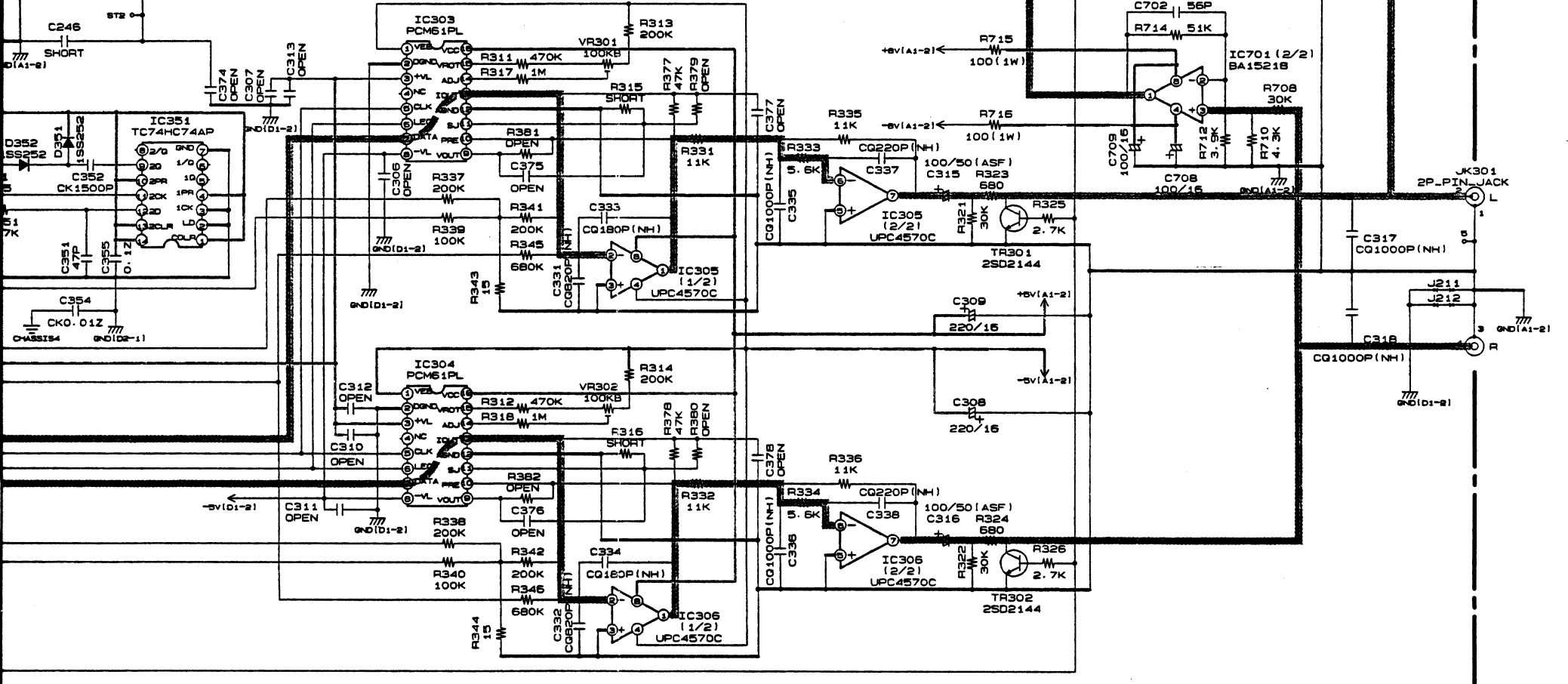
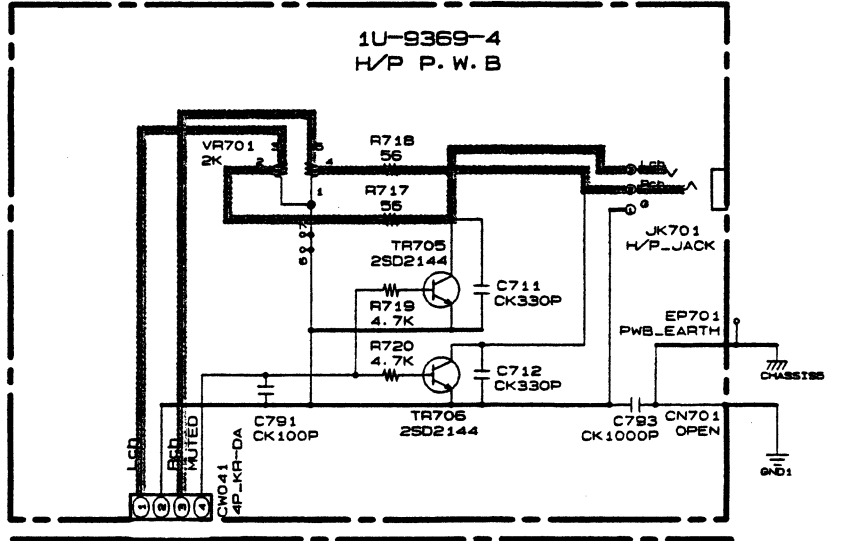
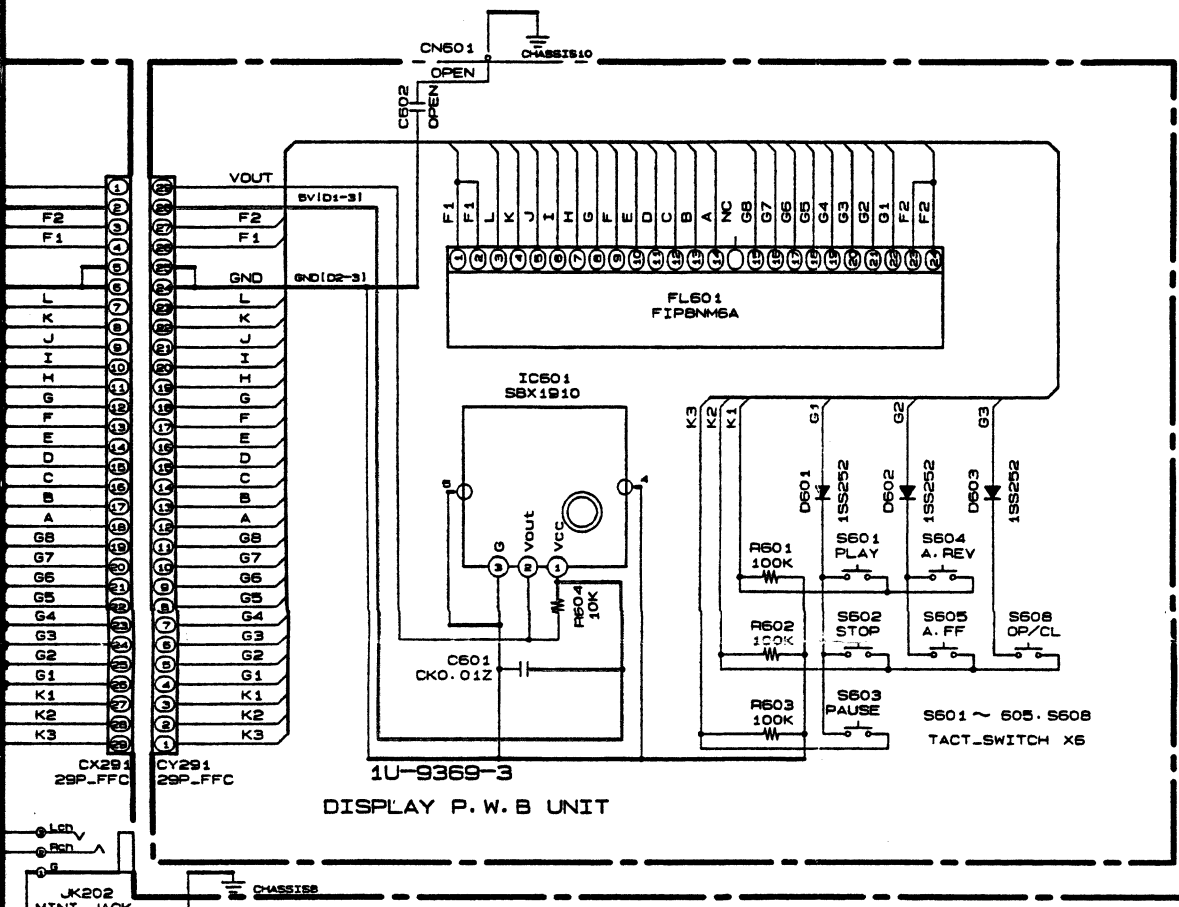

——— +B LINE  
 - - - - -B LINE  
 ——— SIGNAL LINE

A  
B  
C  
D  
E  
F  
G  
H