

# DENON

For U.S.A., Canada  
& Europe model

**Ver. 3**

Please refer to the  
MODIFICATION NOTICE.

**SERVICE MANUAL**

**MODEL DCM-390**  
**DCM-290**  
**DCM-27**  
**DCM-500AE**

**STEREO CD PLAYER**

## 注 意

サービスをおこなう前に、このサービスマニュアルを必ずお読みください。本機は、火災、感電、けがなどに対する安全性を確保するために、さまざまな配慮をおこなっており、また法的には「電気用品安全法」にもとづき、所定の許可を得て製造されております。従ってサービスをおこなう際は、これらの安全性が維持されるよう、このサービスマニュアルに記載されている注意事項を必ずお守りください。

● For purposes of improvement, specifications and design are subject to change without notice.

● 本機の仕様は性能改良のため、予告なく変更することがあります。  
● 補修用性能部品の保有期間は、製造打切後8年です。

● Please use this service manual with referring to the operating instructions without fail.

● 修理の際は、必ず取扱説明書を参照の上、作業を行ってください。

● Some illustrations using in this service manual are slightly different from the actual set.

● 本文中に使用しているイラストは、説明の都合上現物と多少異なる場合があります。

# DENON

TOKYO, JAPAN  
Denon Brand Company, D&M Holdings Inc.

## SAFETY PRECAUTIONS

The following check should be performed for the continued protection of the customer and service technician.

### LEAKAGE CURRENT CHECK

Before returning the unit to the customer, make sure you make either (1) a leakage current check or (2) a line to chassis resistance check. If the leakage current exceeds 0.5 milliamps, or if the resistance from chassis to either side of the power cord is less than 460 kohms, the unit is defective.

### LASER RADIATION

Do not stare into beam or view directly with optical instruments, class 3A laser product.

**CAUTION** Please heed the points listed below during servicing and inspection.

#### ◎ Heed the cautions!

Spots requiring particular attention when servicing, such as the cabinet, parts, chassis, etc., have cautions indicated on labels or seals. Be sure to heed these cautions and the cautions indicated in the handling instructions.

#### ◎ Caution concerning electric shock!

(1) An AC voltage is impressed on this set, so touching internal metal parts when the set is energized could cause electric shock. Take care to avoid electric shock, by for example using an isolating transformer and gloves when servicing while the set is energized, unplugging the power cord when replacing parts, etc.

(2) There are high voltage parts inside. Handle with extra care when the set is energized.

#### ◎ Caution concerning disassembly and assembly!

Though great care is taken when manufacturing parts from sheet metal, there may in some rare cases be burrs on the edges of parts which could cause injury if fingers are moved across them. Use gloves to protect your hands.

#### ◎ Only use designated parts!

The set's parts have specific safety properties (fire resistance, voltage resistance, etc.). For replacement parts, be sure to use parts which have the same properties. In particular, for the important safety parts that are marked  $\triangle$  on wiring diagrams and parts lists, be sure to use the designated parts.

#### ◎ Be sure to mount parts and arrange the wires as they were originally!

For safety reasons, some parts use tape, tubes or other insulating materials, and some parts are mounted away from the surface of printed circuit boards. Care is also taken with the positions of the wires inside and clamps are used to keep wires away from heating and high voltage parts, so be sure to set everything back as it was originally.

#### ◎ Inspect for safety after servicing!

Check that all screws, parts and wires removed or disconnected for servicing have been put back in their original positions, inspect that no parts around the area that has been serviced have been negatively affected, conduct an insulation check on the external metal connectors and between the blades of the power plug, and otherwise check that safety is ensured.

(Insulation check procedure)

Unplug the power cord from the power outlet, disconnect the antenna, plugs, etc., and turn the power switch on. Using a 500V insulation resistance tester, check that the insulation resistance between the terminals of the power plug and the externally exposed metal parts (antenna terminal, headphones terminal, microphone terminal, input terminal, etc.) is 1M $\Omega$  or greater. If it is less, the set must be inspected and repaired.

### CAUTION Concerning important safety parts

Many of the electric and structural parts used in the set have special safety properties. In most cases these properties are difficult to distinguish by sight, and using replacement parts with higher ratings (rated power and withstand voltage) does not necessarily guarantee that safety performance will be preserved. Parts with safety properties are indicated as shown below on the wiring diagrams and parts lists in this service manual. Be sure to replace them with parts with the designated part number.

(1) Schematic diagrams ... Indicated by the  $\triangle$  mark.

(2) Parts lists ... Indicated by the  $\triangle$  mark.

Using parts other than the designated parts could result in electric shock, fires or other dangerous situations.

**注意** サービス、点検時にはつぎのことにご注意願います。

#### ◎ 注意事項をお守りください!

サービスのとき特に注意を必要とする個所についてはキャビネット、部品、シャーシなどにラベルや捺印で注意事項を表示しています。これらの注意書きおよび取扱説明書などの注意事項を必ずお守りください。

#### ◎ 感電に注意!

(1) このセットは、交流電圧が印加されていますので通電時に内部金属部に触れると感電することがあります。従って通電サービス時には、絶縁トランスの使用や手袋の着用、部品交換には、電源プラグを抜くなどして感電にご注意ください。

(2) 内部には高電圧の部分がありますので、通電時の取扱には十分ご注意ください。

#### ◎ 分解、組み立て作業時のご注意!

板金部品の端面の『バリ』は、部品製造時に充分管理をしておりますが、板金端面は鋭利となっている箇所がありますので、部品端面に触れたまま指を動かすとまれに怪我をする場合がありますので十分注意して作業して下さい。手の保護のために手袋を着用してください。

#### ◎ 指定部品の使用!

セットの部品は難燃性や耐電圧など安全上の特性を持ったものとなっています。従って交換部品は、使用されていたものと同じ特性の部品を使用してください。特に配線図、部品表に  $\triangle$  印で指定されている安全上重要な部品は必ず指定のものをご使用ください。

#### ◎ 部品の取付けや配線の引きまわしは、元どおりに!

安全上、テープやチューブなどの絶縁材料を使用したり、プリント基板から浮かして取付けた部品があります。また内部配線は引きまわしやクランプによって発熱部品や高圧部品に接近しないように配慮されていますので、これらは必ず元どおりにしてください。

#### ◎ サービス後は安全点検を!

サービスのために取り外したねじ、部品、配線などが元どおりになっているか、またサービスした個所の周辺を劣化させてしまったところがないかなどを点検し、外部金属端子部と、電源プラグの刃の間の絶縁チェックをおこなうなど、安全性が確保されていることを確認してください。

(絶縁チェックの方法)

電源コンセントから電源プラグを抜き、アンテナやプラグなどを外し、電源スイッチを入れます。500V 絶縁抵抗計を用いて、電源プラグのそれぞれの端子と外部露出金属部 [アンテナ端子、ヘッドホン端子、マイク端子、入力端子など] との間で、絶縁抵抗値が 1 M $\Omega$  以上であること、この値以下のときはセットの点検修理が必要です。

### 注意 安全上重要な部品について

本機に使用している多くの電気部品、および機構部品は安全上、特別な特性を持っています。この特性はほとんどの場合、外観では判別つきにくく、またもとの部品より高い定格(定格電力、耐圧)を持ったものを使用しても安全性が維持されることは、限りません。安全上の特性を持った部品は、このサービスマニュアルの配線図、部品表につぎのように表示していますので必ず指定されている部品番号のものを使用願います。

(1) 配線図...  $\triangle$  マークで表示しています。

(2) 部品表...  $\triangle$  マークで表示しています。

指定された部品と異なるものを使用した場合には、感電、火災などの危険を生じる恐れがあります。

# BLOCK DIAGRAM

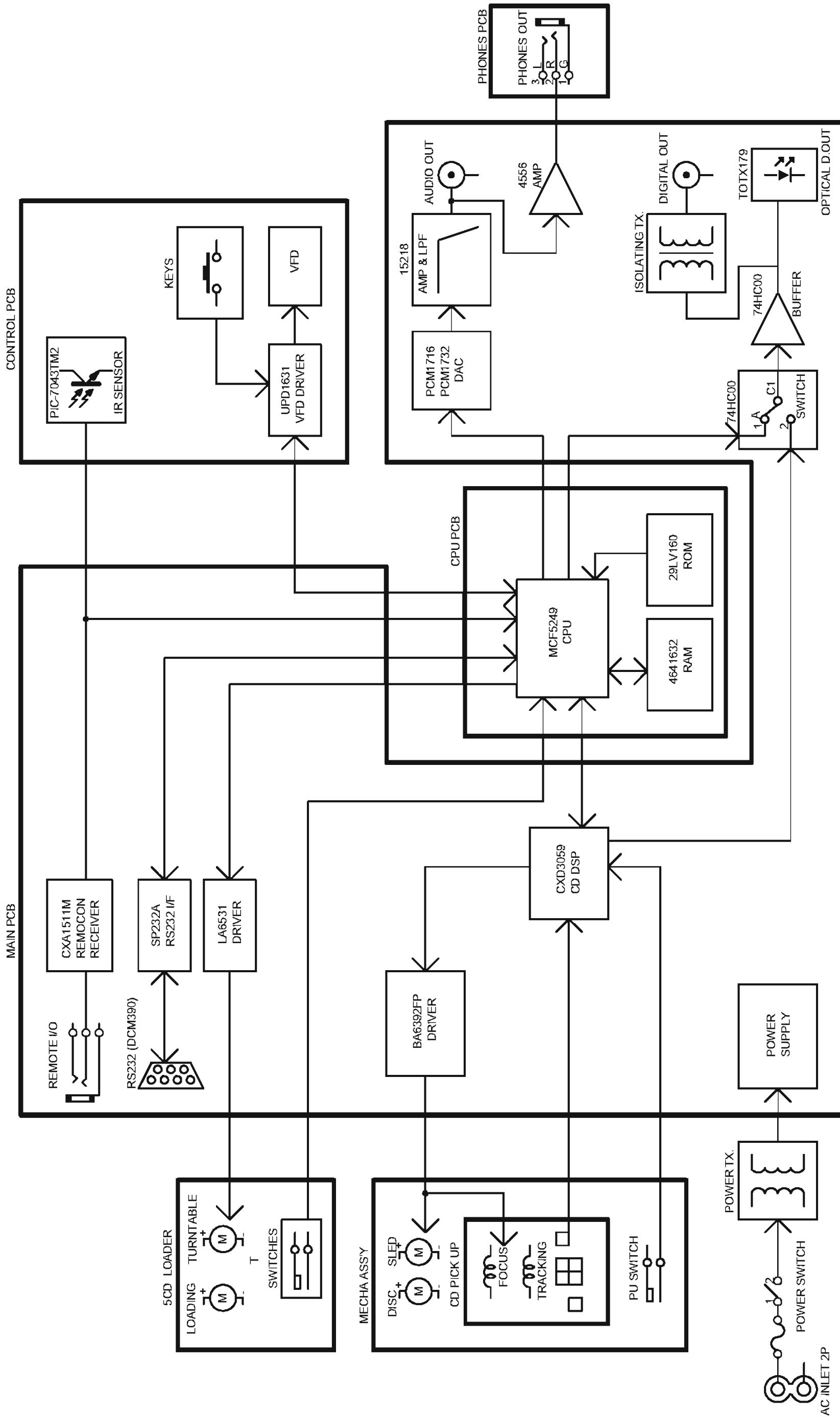

## DISASSEMBLY

(To reassemble, reverse disassembly)

### 1. TOP COVER

Remove 4 screws (A) fixing the Top Cover and 5 screws (A) mounting the Rear Panel, then detach the Top Cover as shown in the arrow direction.

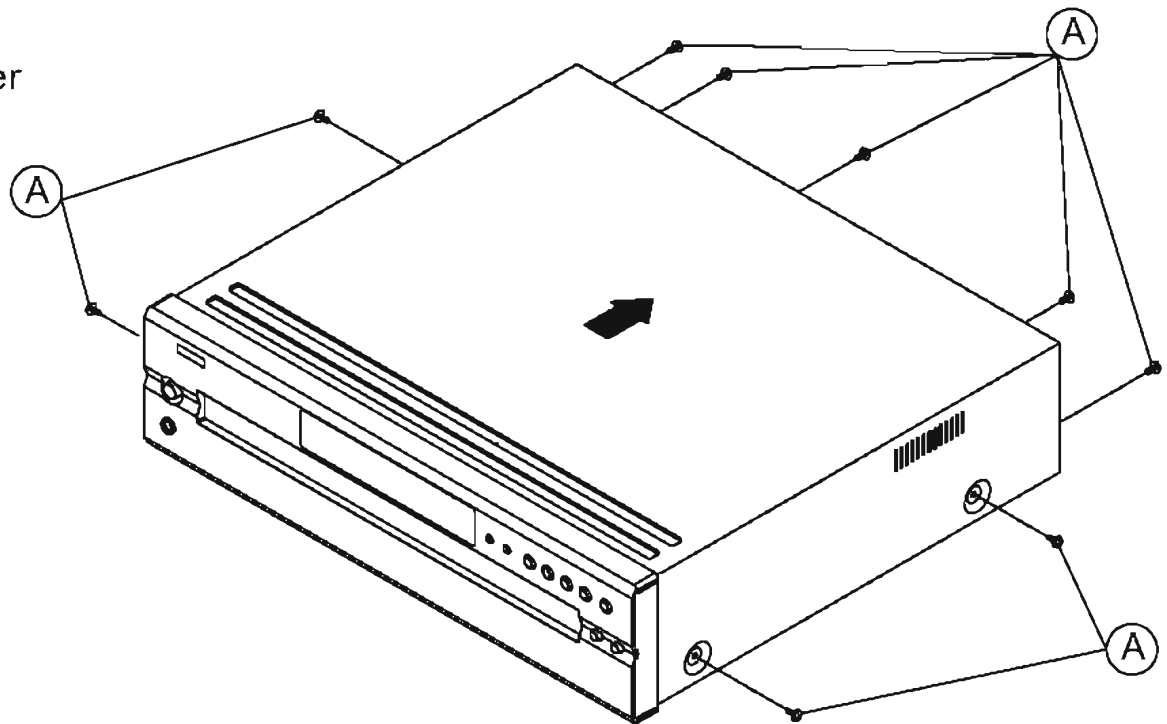

### 2. BACK PANEL

Remove 3 screws (B) mounting the Bottom Cover and 5 screws (C) mounting the Back Panel, then detach the Back Panel as shown in the arrow direction.

**Note:** Only in 3x5mm, other screws can't be used for (B).

**Note:** Do not yet exclude FFC (☆mark)

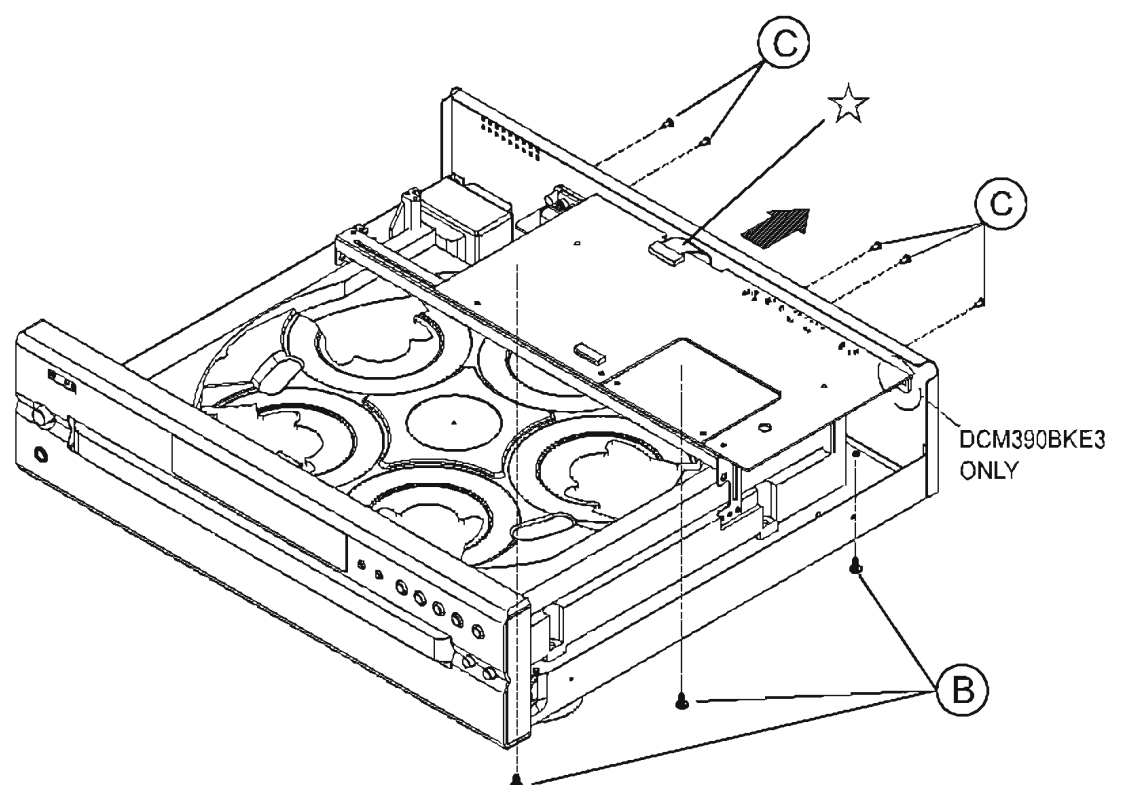

### 3. FRONT PANEL

Remove 2 side screws (D) and 5 below screws (B) mounting the Front Panel, then detach the Front Panel as shown in the arrow direction.

**Note:** Do not yet exclude FFC (☆mark)

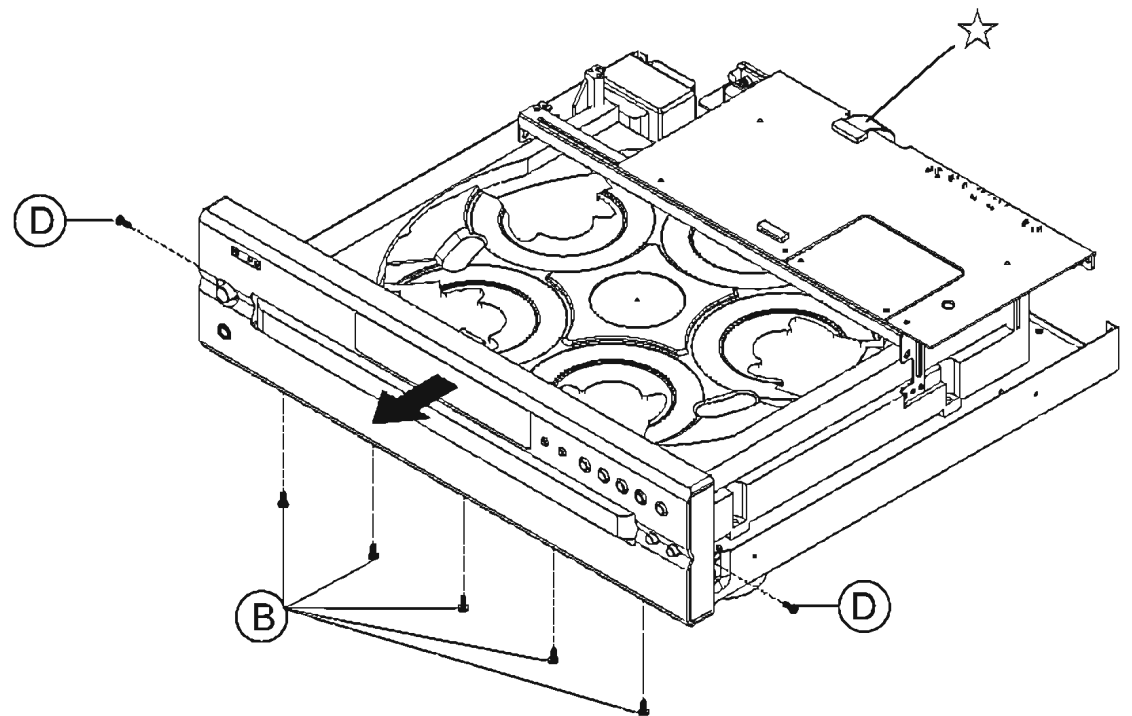

### 4. CONTROL P.W.B. & Phone P.W.B.

Remove 8 screws (E) mounting the Front Panel and 1 (E) screw fixing the Control P.W.B., then detach the Control P.W.B. as shown in the arrow direction.

Remove 2 screws (F) mounting the Front Panel fixing the Phone P.W.B., then detach the Phone P.W.B..

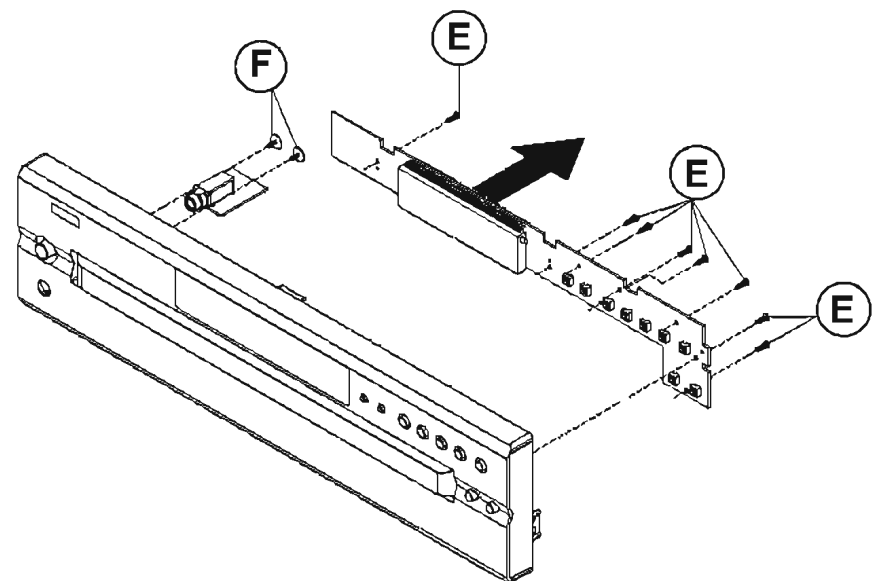

### 5. LOADER ASS'Y & MAIN P.W.B.

Remove 1 screw (G) and 4 screws (H) mounting the Bottom Cover, then detach the Loader Ass'y & Main P.W.B. as shown in the arrow direction.

**Note:** Do not yet exclude FFC (☆mark)

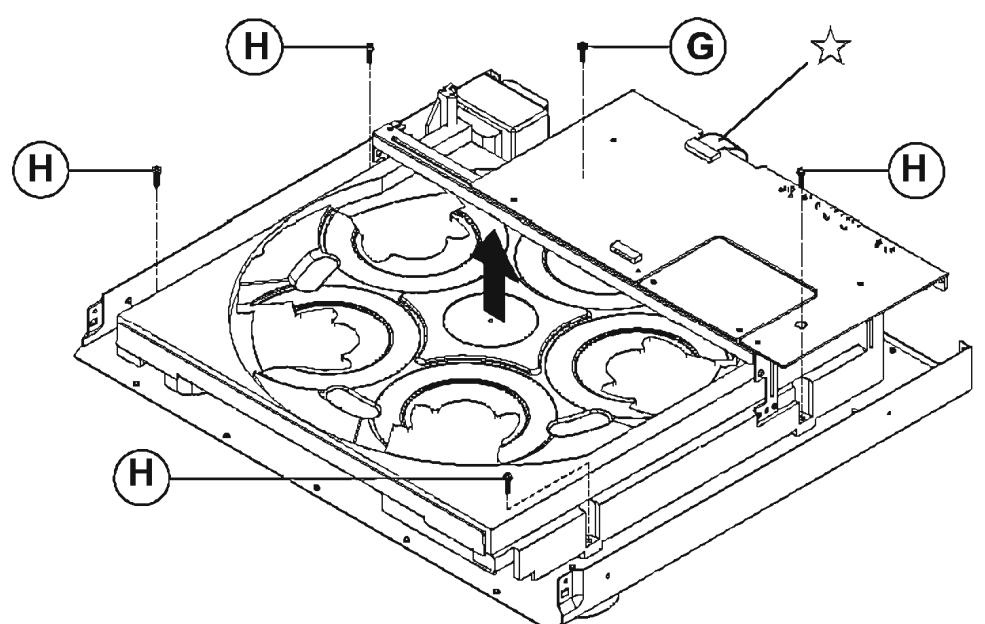

**6. LASER SHORT**

Reverse a Loader ass'y & Main P.W.B. unit and a Laser short-circuit in Pick-up next.

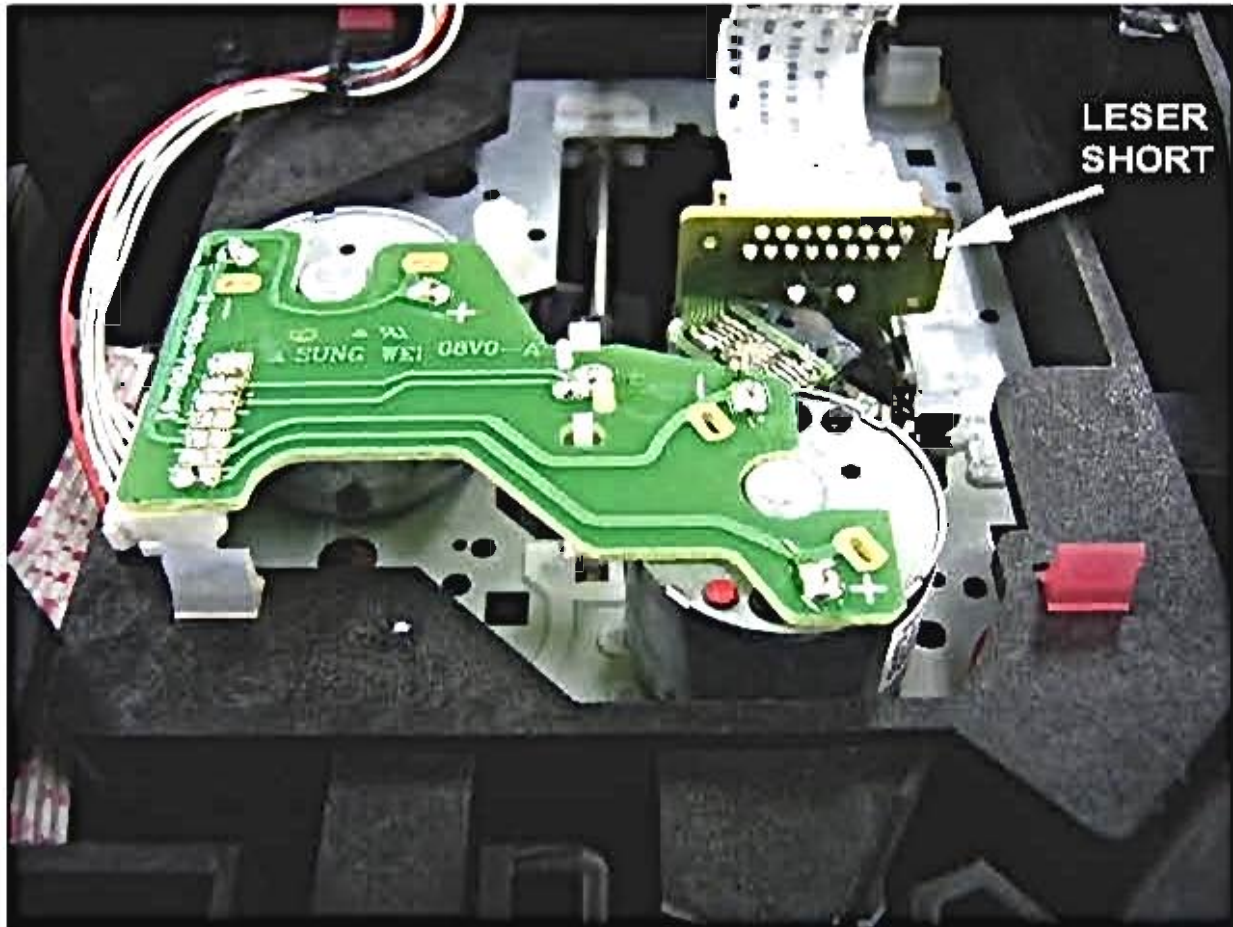

**7. MAIN P.W.B.**

Remove 2 screws (I), 4 screws (J), 1 screw (K) fixing the Main P.W.B. then detach the Main P.W.B. as shown in the arrow direction.

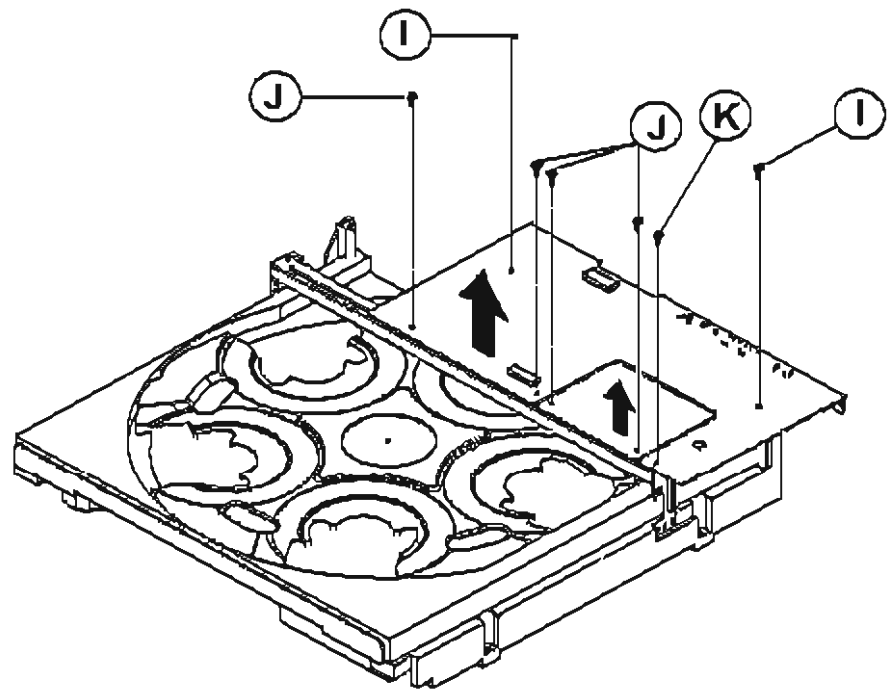

# SEMICONDUCTORS

Only major semiconductors are shown, general semiconductors etc. are omitted to list.  
 主な半導体を記載しています。汎用の半導体は記載を省略しています。

## ● IC's

### CXD3059 (IC 101)

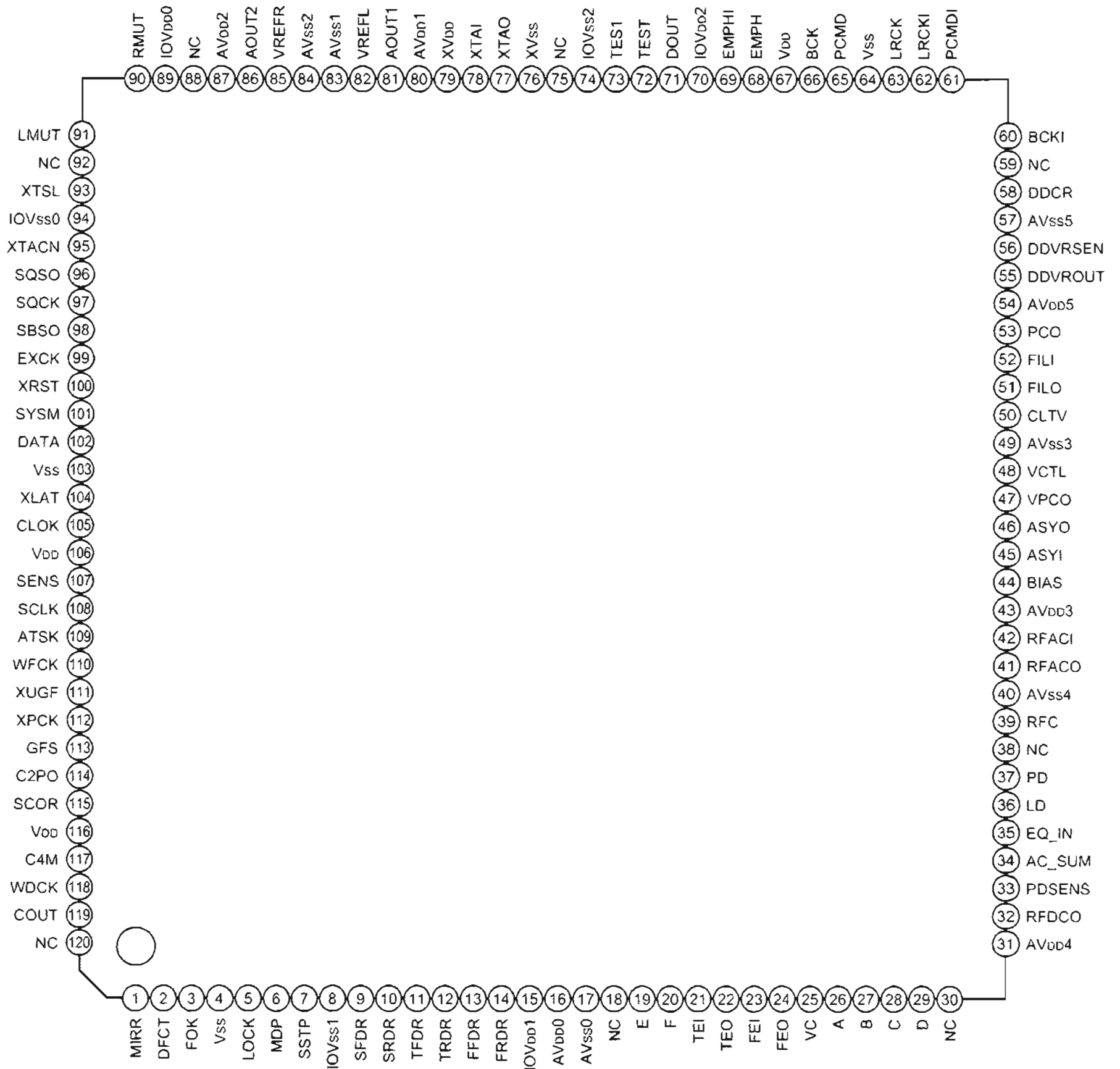

Block Diagram

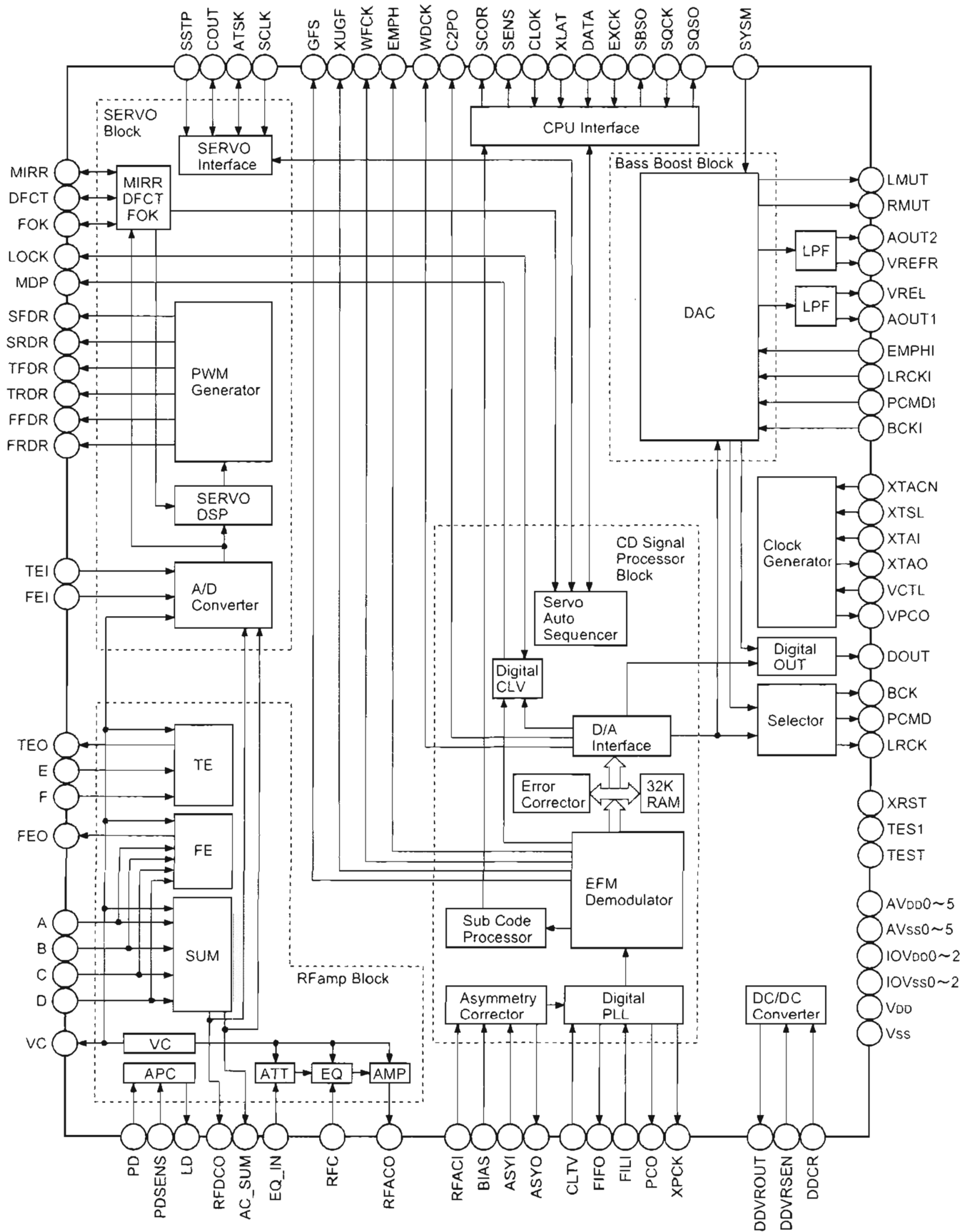



## Pin Description

Power supply	Pin No.	Symbol	I/O		Description
Digital I/O = 3.3V Internal = 2.5V	1	MIRR	I/O	1, 0	Mirror signal input/output.
	2	DFCT	I/O	1, 0	Defect signal input/output.
	3	FOK	I/O	1, 0	Focus OK signal input/output.
	4	Vss	—	—	Internal digital GND.
	5	LOCK	I/O	1, 0	GFS is sampled at 460Hz; when GFS is high, this pin outputs a high signal. If GFS is low eight consecutive samples, this pin outputs low. Or this pin inputs when LKIN = "1".
	6	MDP	O	1, Z, 0	Spindle motor servo control output.
	7	SSTP	I		Disk innermost detection signal input.
	8	IOVss1	—	—	I/O digital GND.
	9	SFDR	O	1, 0	Sled drive output.
	10	SRDR	O	1, 0	Sled drive output.
	11	TFDR	O	1, 0	Tracking drive output.
	12	TRDR	O	1, 0	Tracking drive output.
	13	FFDR	O	1, 0	Focus drive output.
	14	FRDR	O	1, 0	Focus drive output.
	15	IOVdd1	—	—	I/O digital power supply.
A/D 3.3V	16	AVdd0	—	—	Analog power supply.
	17	AVss0	—	—	Analog GND.
—	18	NC	—	—	
RFamp 3.3V	19	E	I		E signal input.
	20	F	I		F signal input.
	21	TEI	I		Tracking error signal input to DSSP block.
	22	TEO	O		Tracking error signal output from RF amplifier block.
	23	FEI	I		Focus error signal input to DSSP block.
	24	FEO	O		Focus error signal output from RF amplifier block.
	25	VC	I/O		Center voltage output from RF amplifier block. Center voltage input to DSSP block by command switch.
	26	A	I		A signal input.
	27	B	I		B signal input.
	28	C	I		C signal input.
	29	D	I		D signal input.
	30	NC	—	—	
	31	AVdd4	—	—	Analog power supply.
	32	RFDCO	I/O		RFDC signal output. RFDC signal input to DSSP block by command switch.
	33	PDSSENS	I		Reference voltage pin for PD.
	34	AC_SUM	O	Analog	RFAC summing amplifier output.

Power supply	Pin No.	Symbol	I/O	Description
RFamp 3.3V	35	EQ_IN	I	Equalizer circuit input.
	36	LD	O	APC amplifier output.
	37	PD	I	APC amplifier input.
	38	NC	— —	
	39	RFC	I	Equalizer cut-off frequency adjustment pin.
	40	AVss4	— —	Analog GND.
	41	RFACO	O	RFAC signal output.
ASYM 3.3V	42	RFACI	I	RFAC signal input or EFM signal input.
	43	AVDD3	— —	Analog power supply.
	44	BIAS	I	Asymmetry circuit constant current input.
	45	ASYI	I	Asymmetry comparator voltage input.
	46	ASYO	O 1, 0	EFM full-swing output. (Low = Vss, High = VDD)
	47	VPCO	O 1, Z, 0	Wide-band EFM PLL charge pump output.
	48	VCTL	I	Wide-band EFM PLL VCO2 control voltage input.
	49	AVss3	— —	Analog GND.
	50	CLTV	I	Multiplier VCO1 control voltage input.
	51	FILO	O Analog	Master PLL (slave = digital PLL) filter output.
	52	FILI	I	Master PLL filter input.
	53	PCO	O 1, Z, 0	Master PLL charge pump output.
DC/DC 3.3V	54	AVDD5	— —	Analog power supply.
	55	DDVROUT	O	DC/DC converter output. Leave open when not using.
	56	DDVRSEN	I	DC/DC converter output voltage monitor pin. Connect to analog power supply when not using.
	57	AVss5	— —	Analog GND.
	58	DDCR	I	DC/DC converter reset pin.
—	59	NC	— —	
Digital I/O = 3.3V Internal = 2.5V	60	BCKI	I	D/A interface bit clock input.
	61	PCMDI	I	D/A interface serial data input. (2's COMP, MSB first)
	62	LRCKI	I	D/A interface LR clock input.
	63	LRCK	O 1, 0	D/A interface LR clock output. $f = F_s$
	64	Vss	— —	Internal digital GND.
	65	PCMD	O 1, 0	D/A interface serial data output. (2's COMP, MSB first)
	66	BCK	O 1, 0	D/A interface bit clock output.
	67	VDD	— —	Internal digital power supply.
	68	EMPH	O 1, 0	High when the playback disc has emphasis, low it has not.
	69	EMPHI	I	High when de-emphasis is ON, low when input OFF.

Power supply	Pin No.	Symbol	I/O		Description
Digital I/O = 3.3V Internal = 2.5V	70	IOV <sub>DD2</sub>	—	—	I/O digital power supply.
	71	DOUT	O	1, 0	Digital Out output.
	72	TEST	I		Test pin. Normally GND.
	73	TES1	I		Test pin. Normally GND.
	74	IOV <sub>SS2</sub>	—	—	I/O digital GND.
—	75	NC	—	—	
X'tal 2.5V	76	XV <sub>SS</sub>	—	—	Master clock GND.
	77	XTAO	O		Crystal oscillation circuit output.
	78	XTAI	I		Crystal oscillation circuit input.
	79	XV <sub>DD</sub>	—	—	Master clock power supply.
Lch 3.3V	80	AV <sub>DD1</sub>	—	—	Analog power supply.
	81	AOUT1	O		Lch analog output.
	82	VREFL	O		Lch reference voltage.
	83	AV <sub>SS1</sub>	—	—	Analog GND.
Rch 3.3V	84	AV <sub>SS2</sub>	—	—	Analog GND.
	85	VREFR	O		Rch reference voltage.
	86	AOUT2	O		Rch analog output.
	87	AV <sub>DD2</sub>	—	—	Analog power supply.
—	88	NC	—	—	
Digital I/O = 3.3V Internal = 2.5V	89	IOV <sub>DD0</sub>	—	—	I/O digital power supply.
	90	RMUT	O	1, 0	Rch "0" detection flag.
	91	LMUT	O	1, 0	Lch "0" detection flag.
	92	NC	—	—	
	93	XTSL	I		Crystal selection input. Low when the crystal is 16.9344MHz; high when the crystal is 33.8688MHz.
	94	IOV <sub>SS0</sub>	—	—	I/O digital GND.
	95	XTACN	I		Oscillation circuit control. Self-oscillation when high, oscillation stop when low.
	96	SQSO	O	1, 0	Subcode Q 80-bit and PCM peak and level data output. CD TEXT data output.
	97	SQCK	I		SQSO readout clock input.
	98	SBSO	O	1, 0	Subcode P to W serial output.
	99	EXCK	I		SBSO readout clock input.
	100	XRST	I		System reset. Reset when low.
	101	SYSM	I		Mute input. Muted when high.
	102	D ATA	I		Serial data input from CPU.
	103	V <sub>SS</sub>	—	—	Internal digital GND.
104	XLAT	I		Latch input from CPU. The serial data is latched at the falling edge.	

Power supply	Pin No.	Symbol	I/O		Description
Digital I/O = 3.3V Internal = 2.5V	105	CLOK	I		Serial data transfer clock input from CPU.
	106	V <sub>DD</sub>	—	—	Internal digital power supply.
	107	SENS	O	1, 0	SENS output to CPU.
	108	SCLK	I		SENS serial data readout clock input.
	109	ATSK	I/O	1, 0	Anti-shock input/output.
	110	WFCK	O	1, 0	WFCK output.
	111	XUGF	O	1, 0	XUGF output. Output MNT0, RFCK, SOUT by command switch.
	112	XPCK	O	1, 0	XPCK output. Output MNT1, SOCK by command switch.
	113	GFS	O	1, 0	GFS output. Output MNT2, XROF, XOLT by command switch.
	114	C2PO	O	1, 0	C2PO output. Output MNT3, GTOP by command switch.
	115	SCOR	O	1, 0	High output when the subcode sync, S0 or S1, is detected.
	116	V <sub>DD</sub>	—	—	Internal digital power supply.
	117	C4M	O	1, 0	4.2336MHz output. 1/4 frequency-division output of the V16M in CAV-W mode and variable pitch mode.
	118	WDCK	O	1, 0	Word clock output. $f = 2Fs$ . GRSCOR output by command switch.
119	COUT	I/O	1, 0	Track number count signal input/output.	
120	NC	—	—		

## K4S641632E (IC 202)

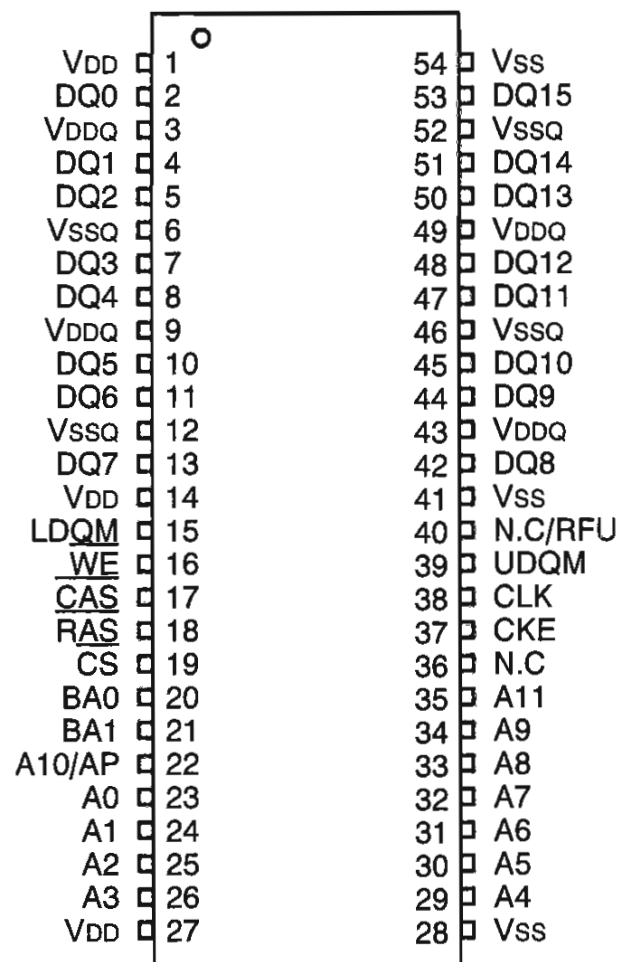

54Pin TSOP (II)  
(400mil x 875mil)  
(0.8 mm Pin pitch)

## PIN FUNCTION DESCRIPTION

Pin	Name	Input Function
CLK	System clock	Active on the positive going edge to sample all inputs.
$\overline{\text{CS}}$	Chip select	Disables or enables device operation by masking or enabling all inputs except CLK, CKE and L(U)DQM
CKE	Clock enable	Masks system clock to freeze operation from the next clock cycle. CKE should be enabled at least one cycle prior to new command. Disable input buffers for power down in standby.
A0 ~ A11	Address	Row/column addresses are multiplexed on the same pins. Row address : RA0 ~ RA11, Column address : CA0 ~ CA7
BA0 ~ BA1	Bank select address	Selects bank to be activated during row address latch time. Selects bank for read/write during column address latch time.
$\overline{\text{RAS}}$	Row address strobe	Latches row addresses on the positive going edge of the CLK with $\overline{\text{RAS}}$ low. Enables row access & precharge.
$\overline{\text{CAS}}$	Column address strobe	Latches column addresses on the positive going edge of the CLK with $\overline{\text{CAS}}$ low. Enables column access.
$\overline{\text{WE}}$	Write enable	Enables write operation and row precharge. Latches data in starting from $\overline{\text{CAS}}$ , $\overline{\text{WE}}$ active.
L(U)DQM	Data input/output mask	Makes data output Hi-Z, tSHZ after the clock and masks the output. Blocks data input when L(U)DQM active.
DQ0 ~ 15	Data input/output	Data inputs/outputs are multiplexed on the same pins.
VDD/VSS	Power supply/ground	Power and ground for the input buffers and the core logic.
VDDQ/VSSQ	Data output power/ground	Isolated power supply and ground for the output buffers to provide improved noise immunity.
N.C/RFU	No connection /reserved for future use	This pin is recommended to be left No Connection on the device.

K4S641632E Block Diagram

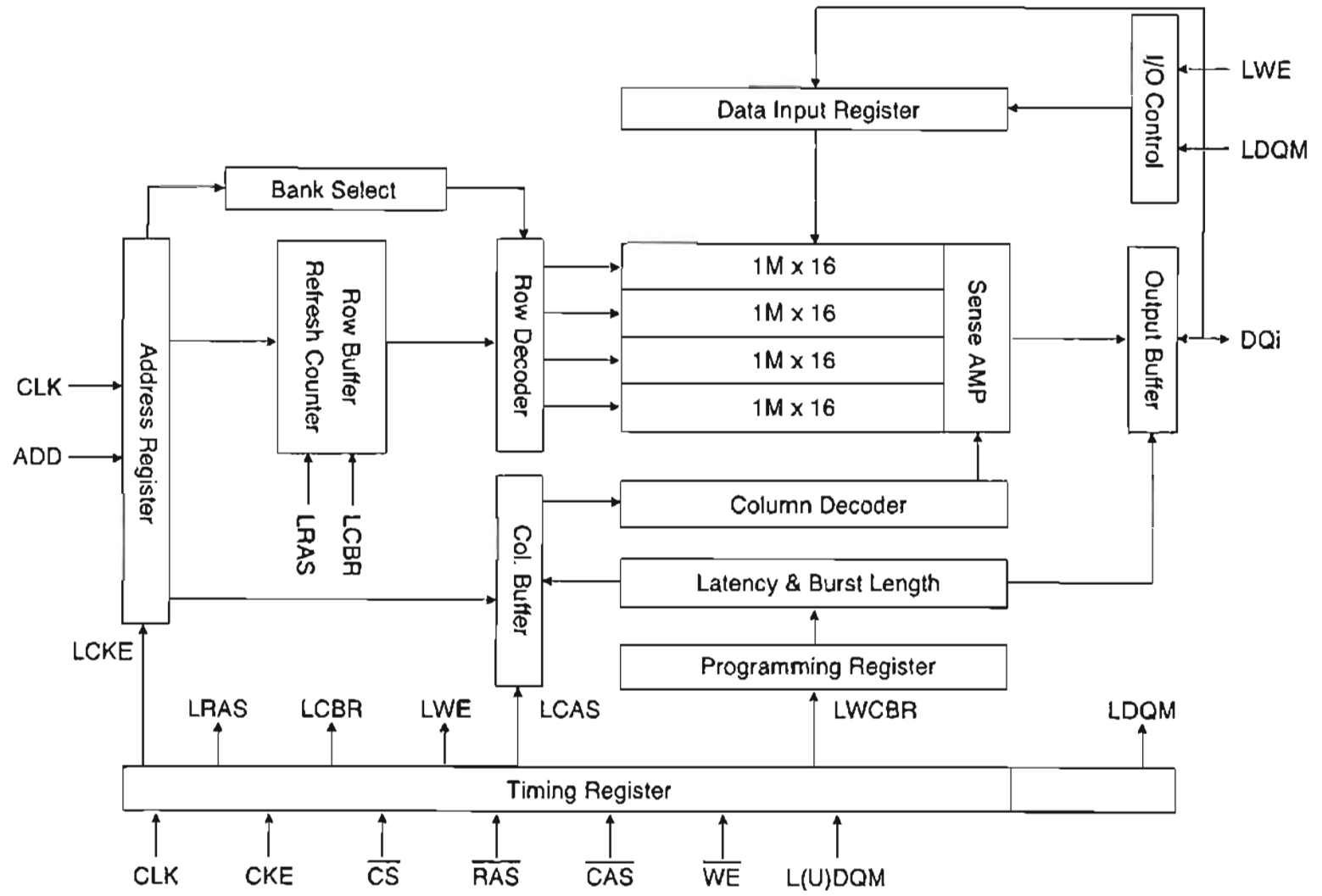

UPD1631 (IC 401)

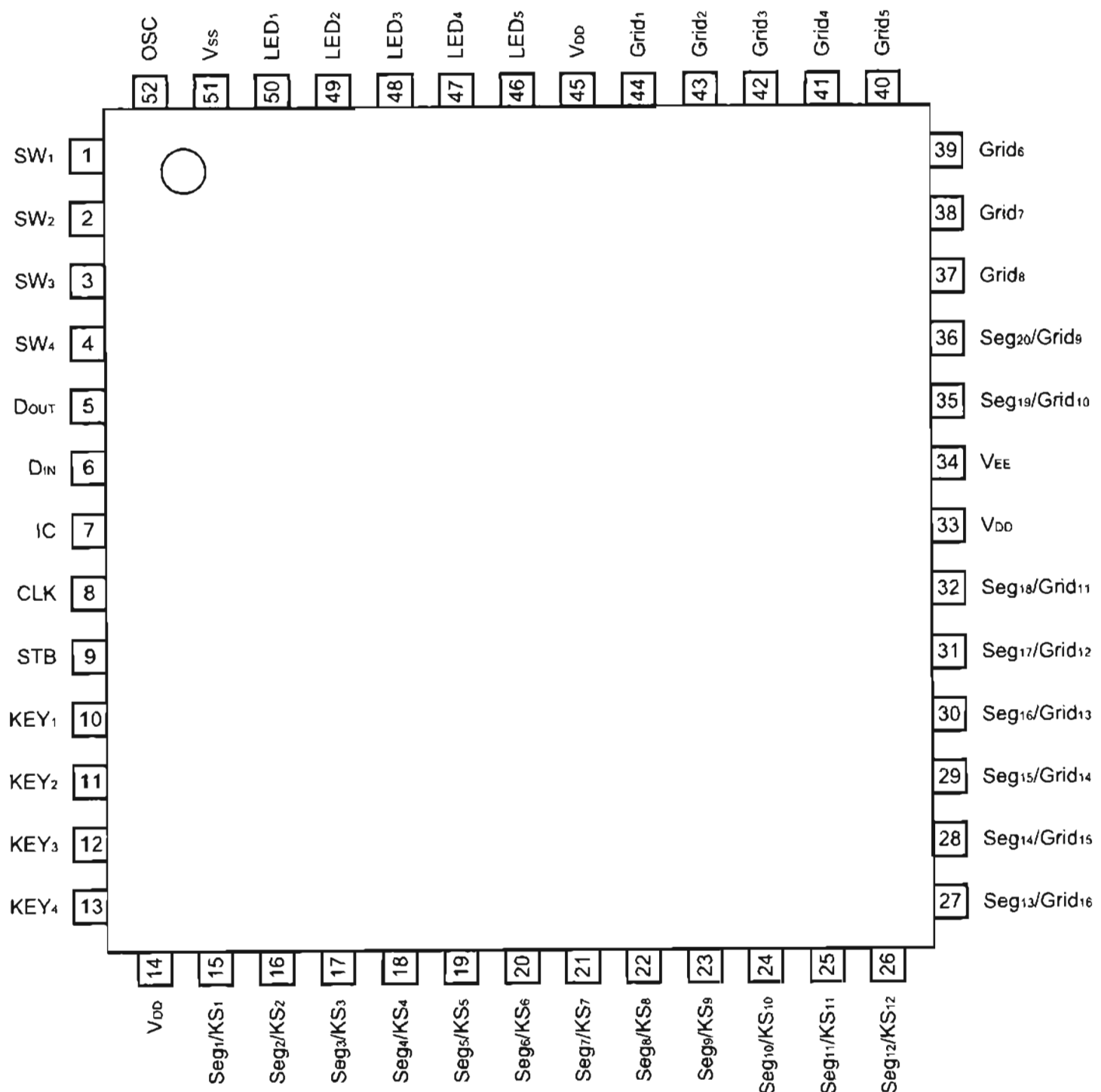

## UPD16311 Block Diagram

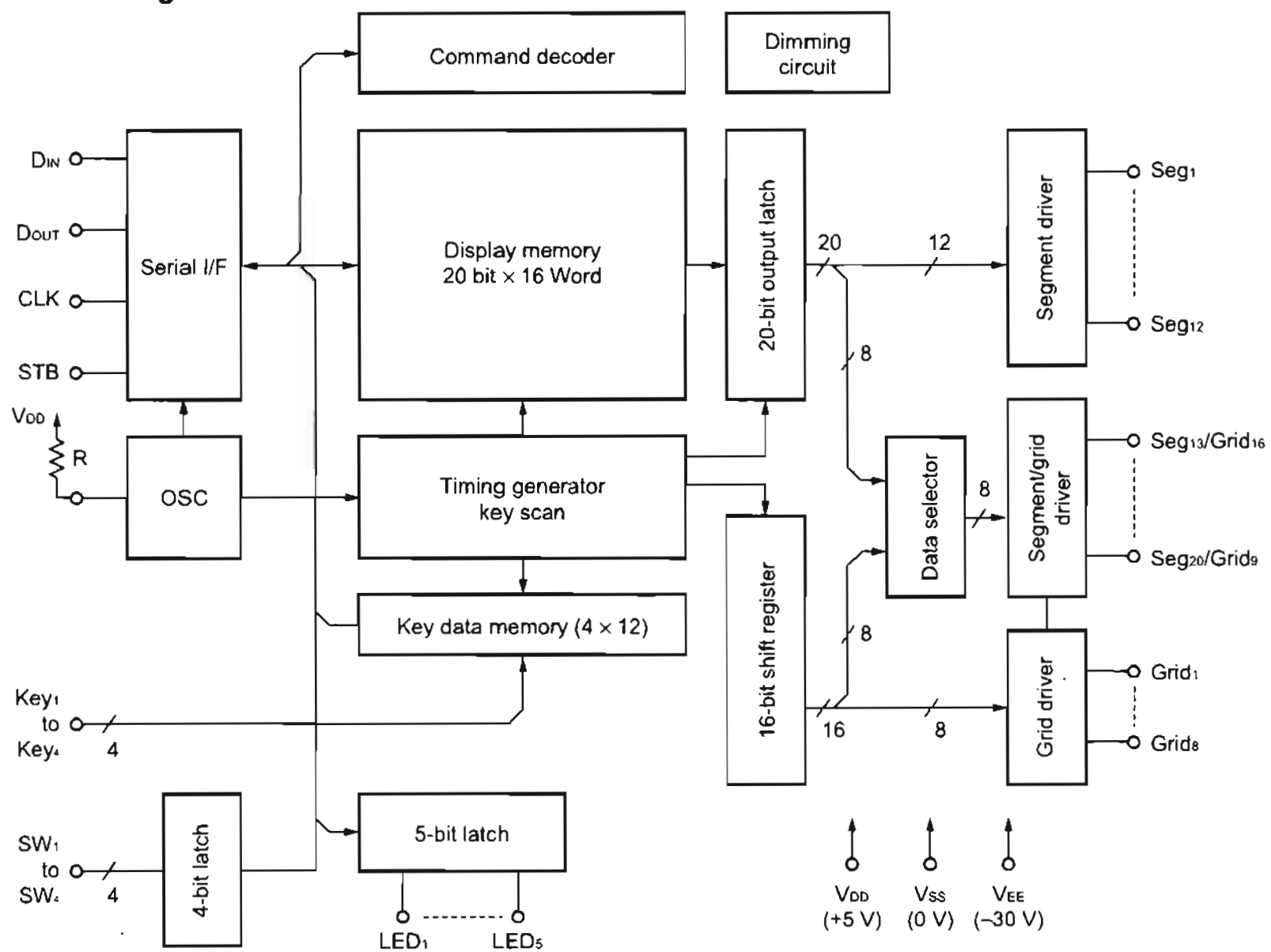

## UPD16311 Pin Description

Pin No.	Symbol	Pin Name	Description
6	DIN	Data input	Inputs serial data at rising edge of shift clock, starting from lower bit.
5	DOUT	Data output	Outputs serial data at falling edge of shift clock, starting from lower bit. This is N-ch open-drain output pin.
9	STB	Strobe	Initializes serial interface at rising or falling edge to make $\mu$ PD16311 waiting for reception of command. Data input after STB has fallen is processed as command. While command data is processed, current processing is stopped, and serial interface is initialized. While STB is high, CLK is ignored.
8	CLK	Clock input	Reads serial data at rising edge, and outputs data at falling edge.
52	OSC	Oscillator pin	Connect resistor for determining oscillation frequency to this pin.
15 to 26	Seg <sub>1</sub> /KS <sub>1</sub> to Seg <sub>12</sub> /KS <sub>12</sub>	High-voltage output (segment)	Segment output pins (Dual function as key source)
44 to 37	Grid <sub>1</sub> to Grid <sub>6</sub>	High-voltage output (grid)	Grid output pins
27 to 32 35 to 36	Seg <sub>13</sub> /Grid <sub>16</sub> to Seg <sub>20</sub> /Grid <sub>9</sub>	High-voltage output (segment/grid)	These pins are selectable for segment or grid output.
50 to 46	LED <sub>1</sub> to LED <sub>5</sub>	LED output	CMOS output. +20 mA max.
10 to 13	Key <sub>1</sub> to Key <sub>4</sub>	Key data input	Data input to these pins is latched at end of display cycle.
1 to 4	SW <sub>1</sub> to SW <sub>4</sub>	Switch input	These pins constitute 4-bit general-purpose input port.
14, 33, 45	V <sub>DD</sub>	Logic power	5 V $\pm$ 10 %
51	V <sub>SS</sub>	Logic ground	Connect this pin to GND of system.
34	V <sub>EE</sub>	Pull-down level	V <sub>DD</sub> - 35 V max.
7	IC	Internally connected	Be sure to leave this pin open (this pin is at V <sub>DD</sub> level).

SCF5249 (IC 201)

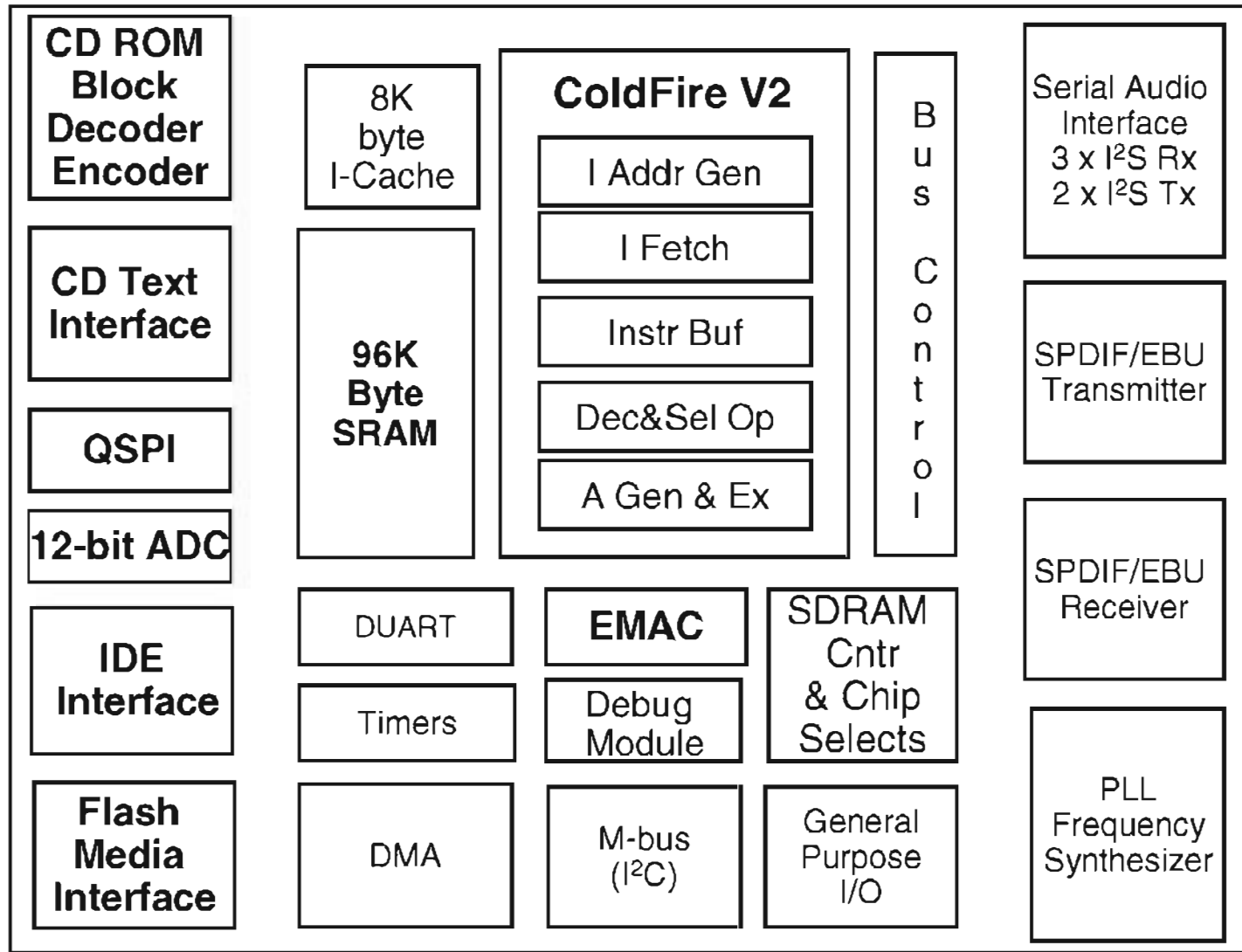

M29W800DB (IC 203)

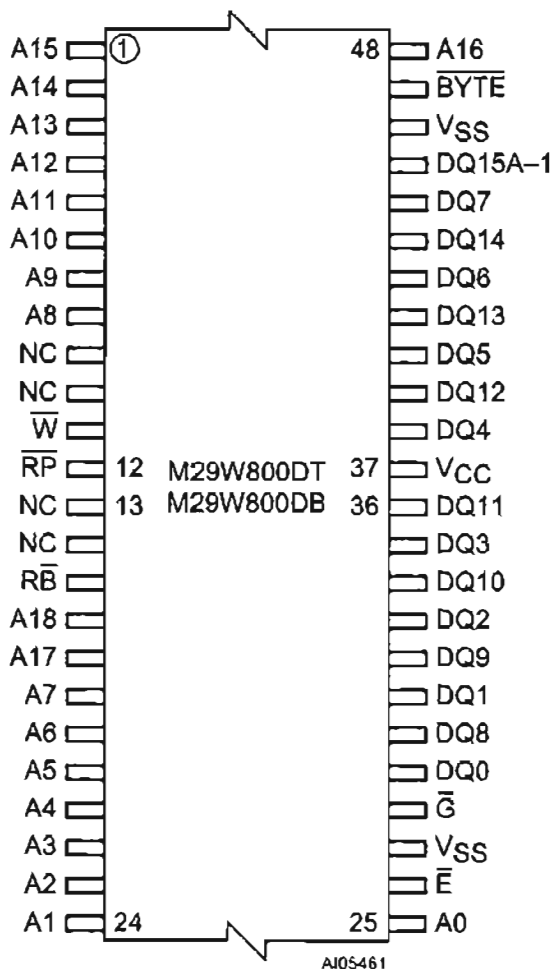

Pin Description

Signal	Description
A0-A18	Address Inputs
DQ0-DQ7	Data Inputs/Outputs
DQ8-DQ14	Data Inputs/Outputs
DQ15A-1	Data Input/Output or Address Input
E	Chip Enable
G	Output Enable
W	Write Enable
RP	Reset/Block Temporary Unprotect
RB	Ready/Busy Output (not available on SO44 package)
BYTE	Byte/Word Organization Select
V <sub>CC</sub>	Supply Voltage
V <sub>SS</sub>	Ground
NC	Not Connected Internally



## BA6392FP (IC 102)

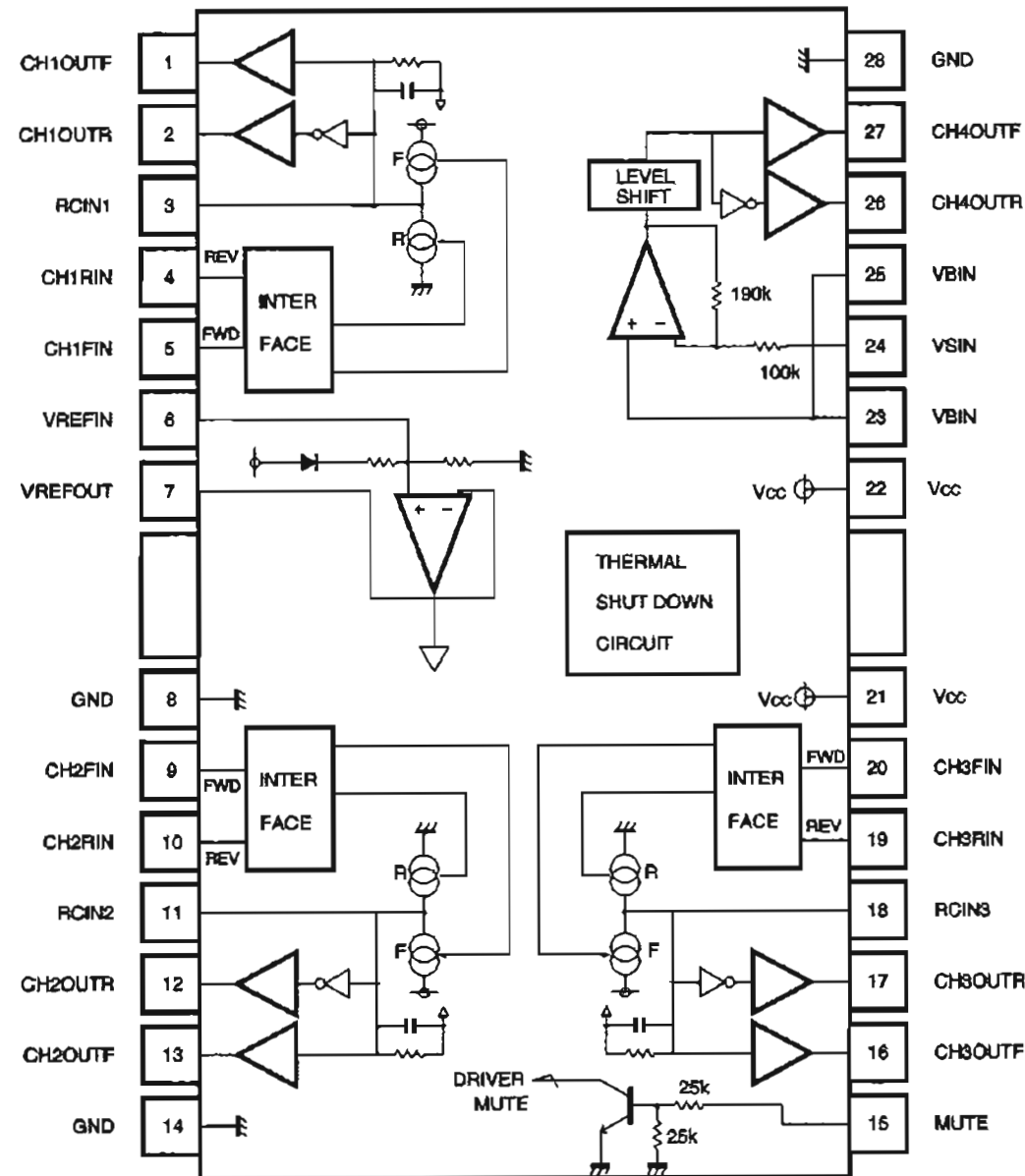

## Pin Description

Pin No.	Pin name	Function
1	CH1OUT F	Driver channel 1 forward output
2	CH1OUT R	Driver channel 1 reverse output
3	RC IN1	Connect to attached resistor/capacitor (1)
4	CH1 RIN	Driver channel 1 reverse input
5	CH1 FIN	Driver channel 1 forward input
6	VREF IN	Internal reference amplifier input
7	VREF OUT	Internal reference amplifier output
8	GND	Ground for internal reference and internal power circuit
9	CH2 FIN	Driver channel 2 forward input
10	CH2 RIN	Driver channel 2 reverse input
11	RC IN2	Connect to attached resistor/capacitor (2)
12	CH2OUT R	Driver channel 2 reverse output
13	CH2OUT F	Driver channel 2 forward output
14	GND	Ground
15	MUTE	Driver mute control input
16	CH3OUT F	Driver channel 3 forward output
17	CH3OUT R	Driver channel 3 reverse output
18	RC IN3	Connect to attached resistor/capacitor (3)
19	CH3 RIN	Driver channel 3 reverse input
20	CH3 FIN	Driver channel 3 forward input
21	Vcc	Power supply
22	Vcc	Power supply
23	VBIN	Driver channel 4 bias input *
24	VSIN	Driver channel 4 input
25	VBIN	Driver channel 4 bias input *
26	CH4OUT R	Driver channel 4 reverse output
27	CH4OUT F	Driver channel 4 forward output
28	GND	Ground

\* Pin 23 and pin 25 are shorted internally.

**SP233ACP (IC 104)**

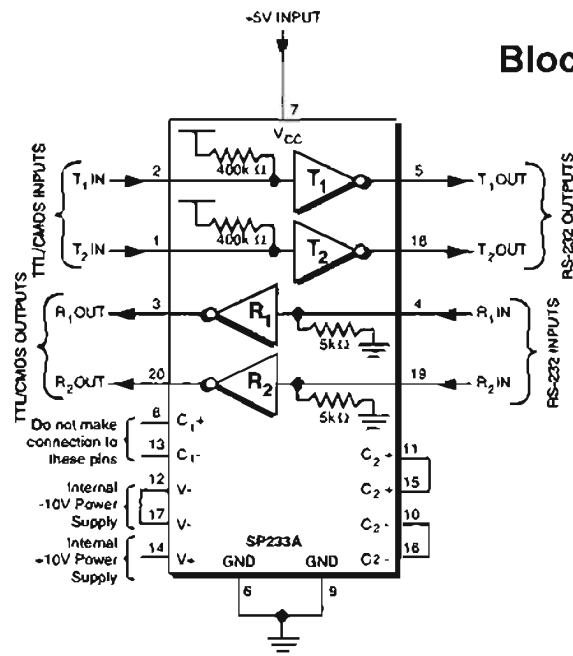
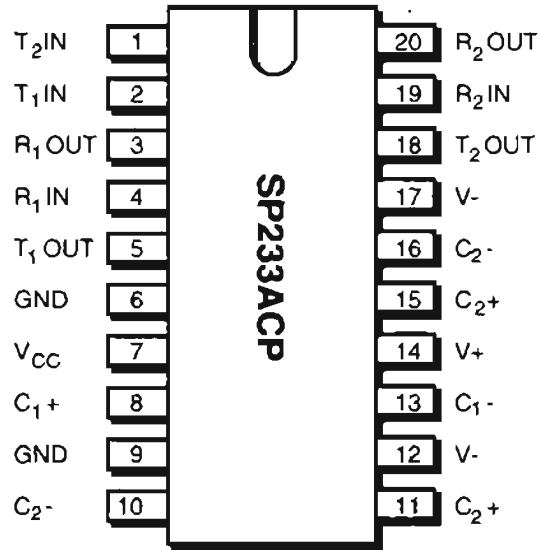

**Block Diagram**

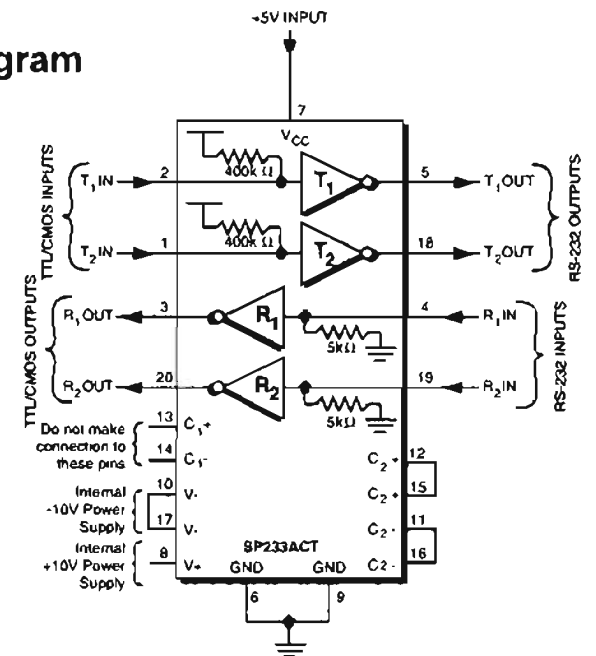

**LA6531 (IC 106)**

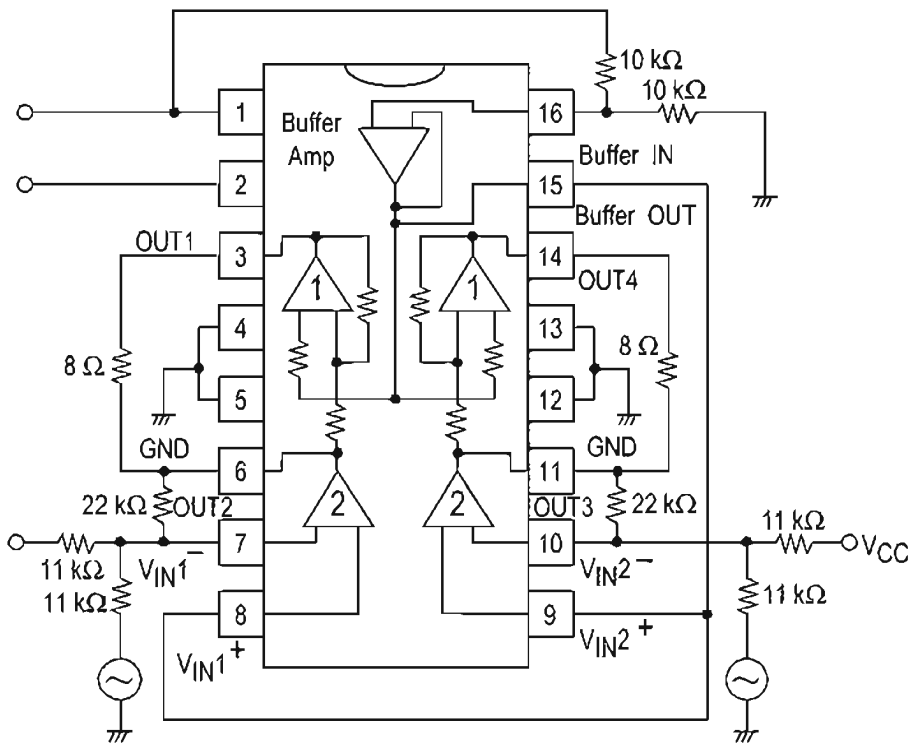

**Pin Description**

Type No.	Functions	Io max (A)	Pd max (W)	Vcc max (V)
LA6531	<ul style="list-style-type: none"> <li>◆ Built-in muting circuits, bridge connection</li> <li>◆ Amp 1 to 4 and buffer outputs are OFF when mute is ON.</li> <li>◆ Thermal shutdown circuit built in</li> </ul>	0.7	1.9	16

**CXA1511L/M (IC 105)**

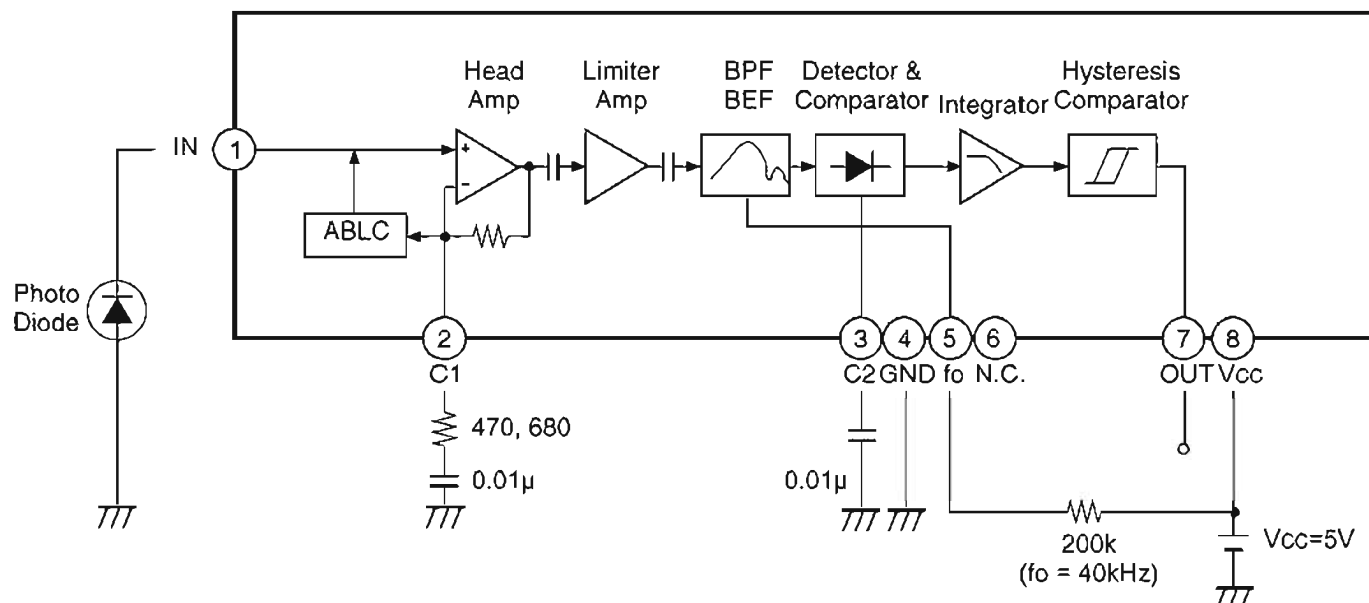

PCM1732 (IC 107)

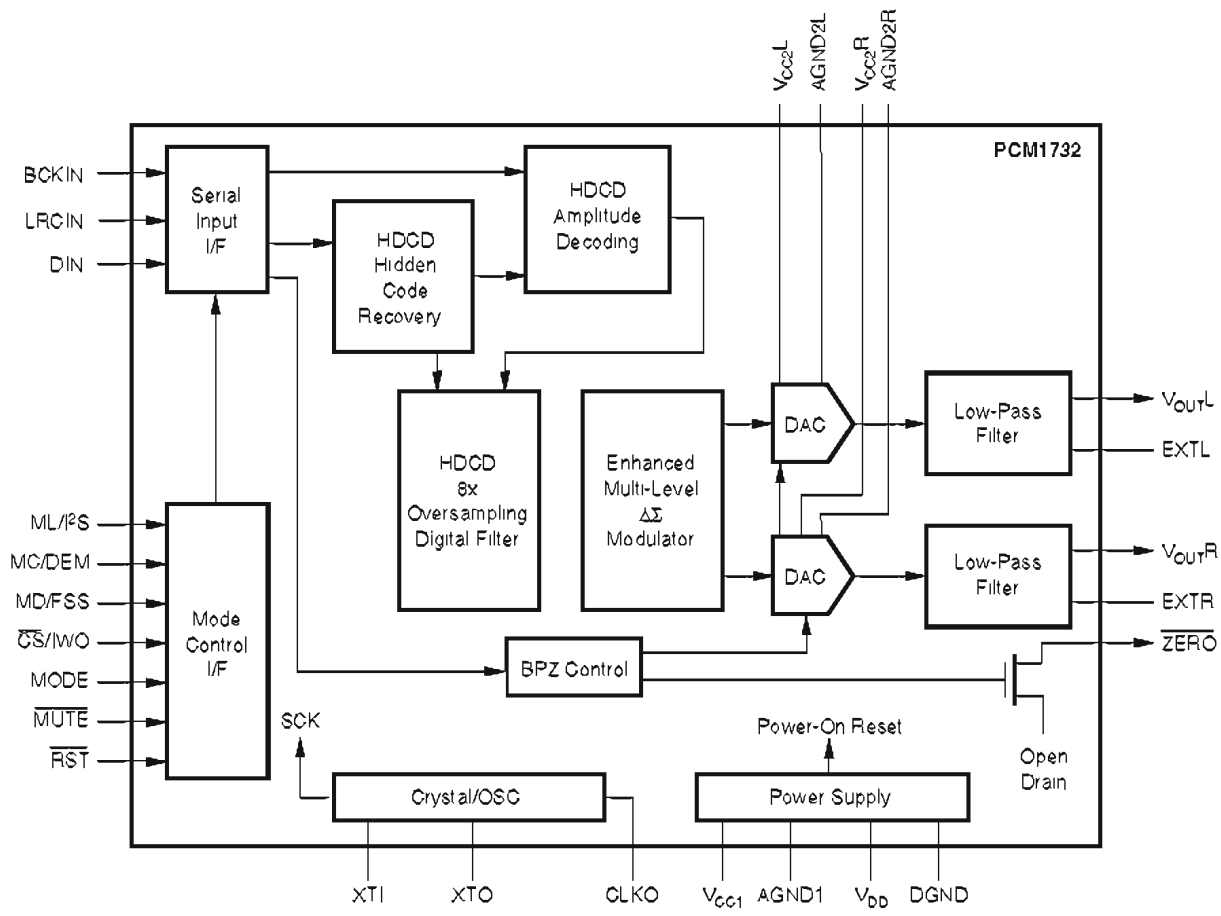

BA033FP (IC 02)  
BA08T (IC 03)

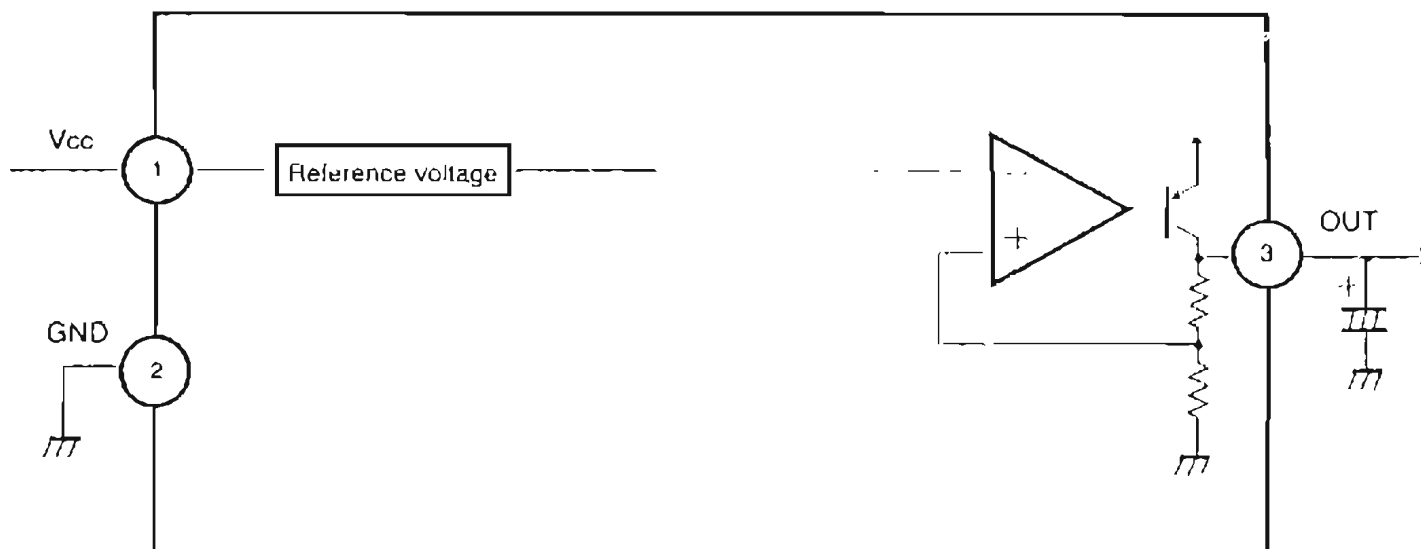

74HCU04 (IC 103)

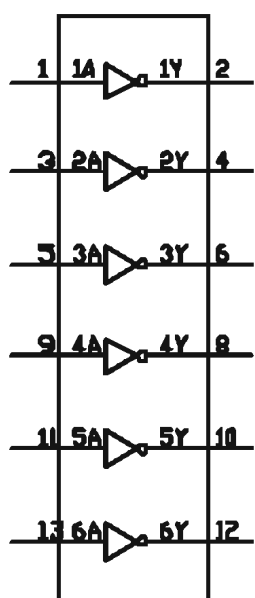

# PRINTED WIRING BOARD

## SERVO P.W.B. UNIT (for DCM-390)

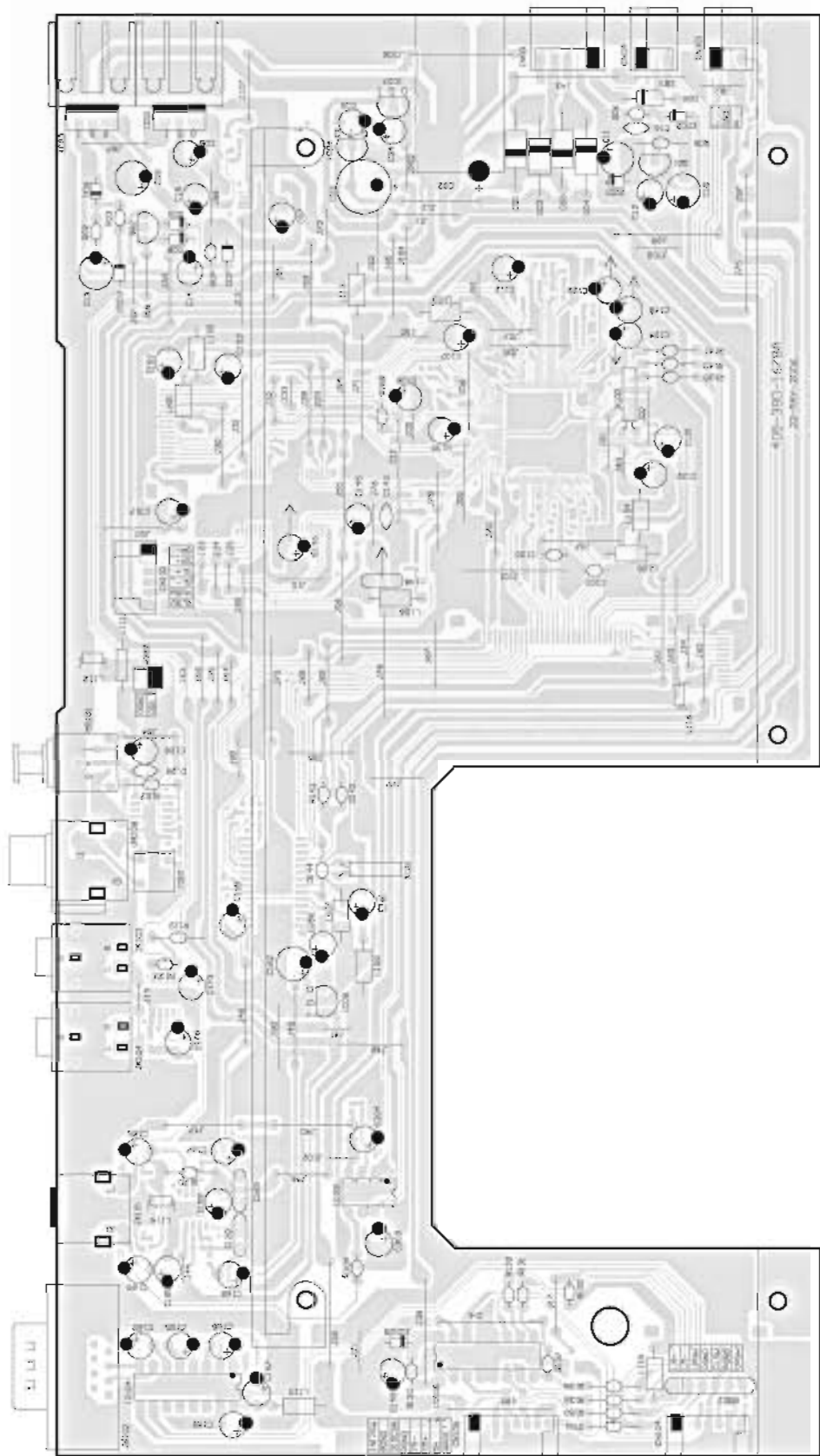

COMPONENT SIDE

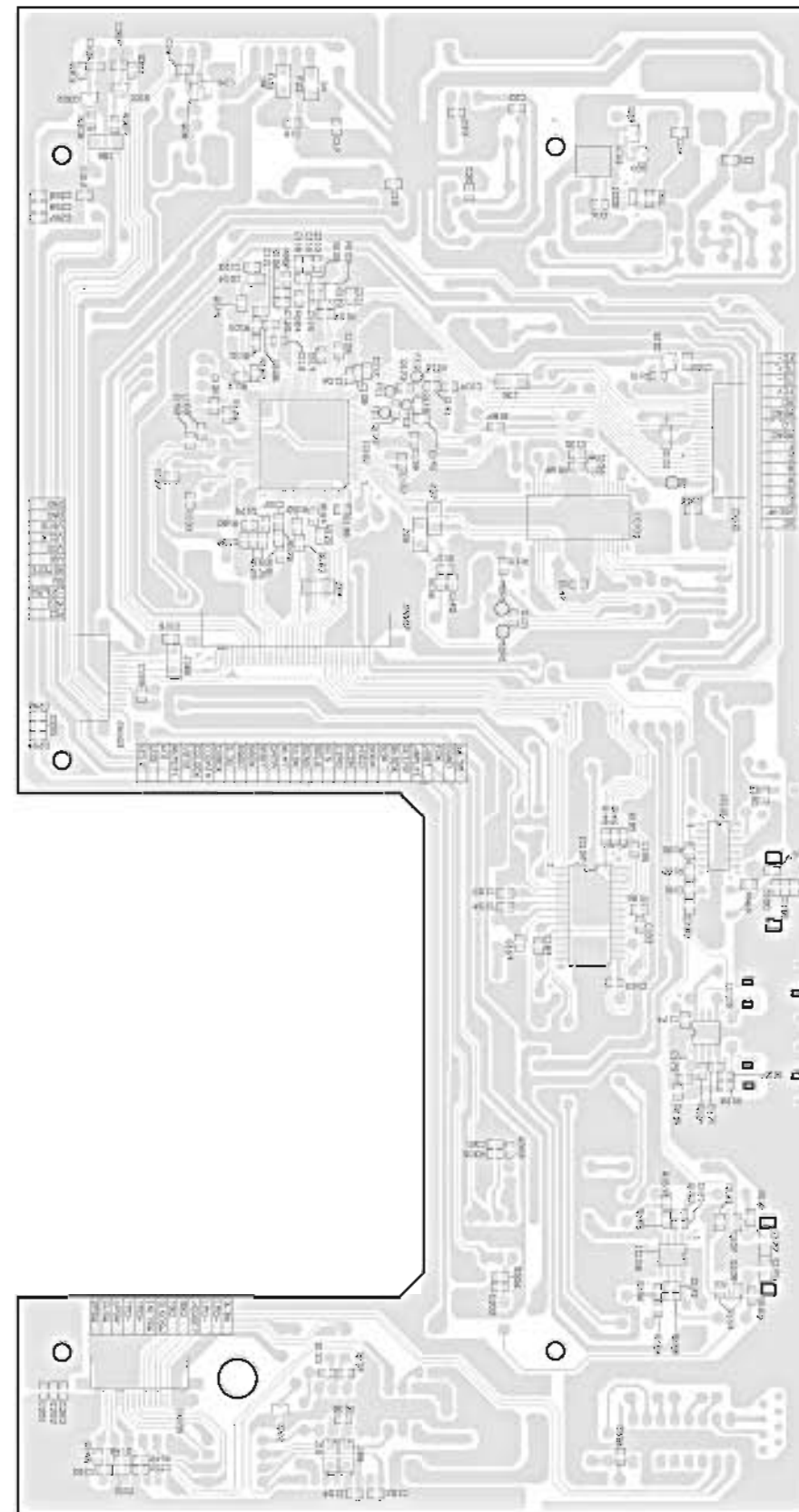

FOIL SIDE

SERVO P.W.B. UNIT (for DCM-290/27/500AE)

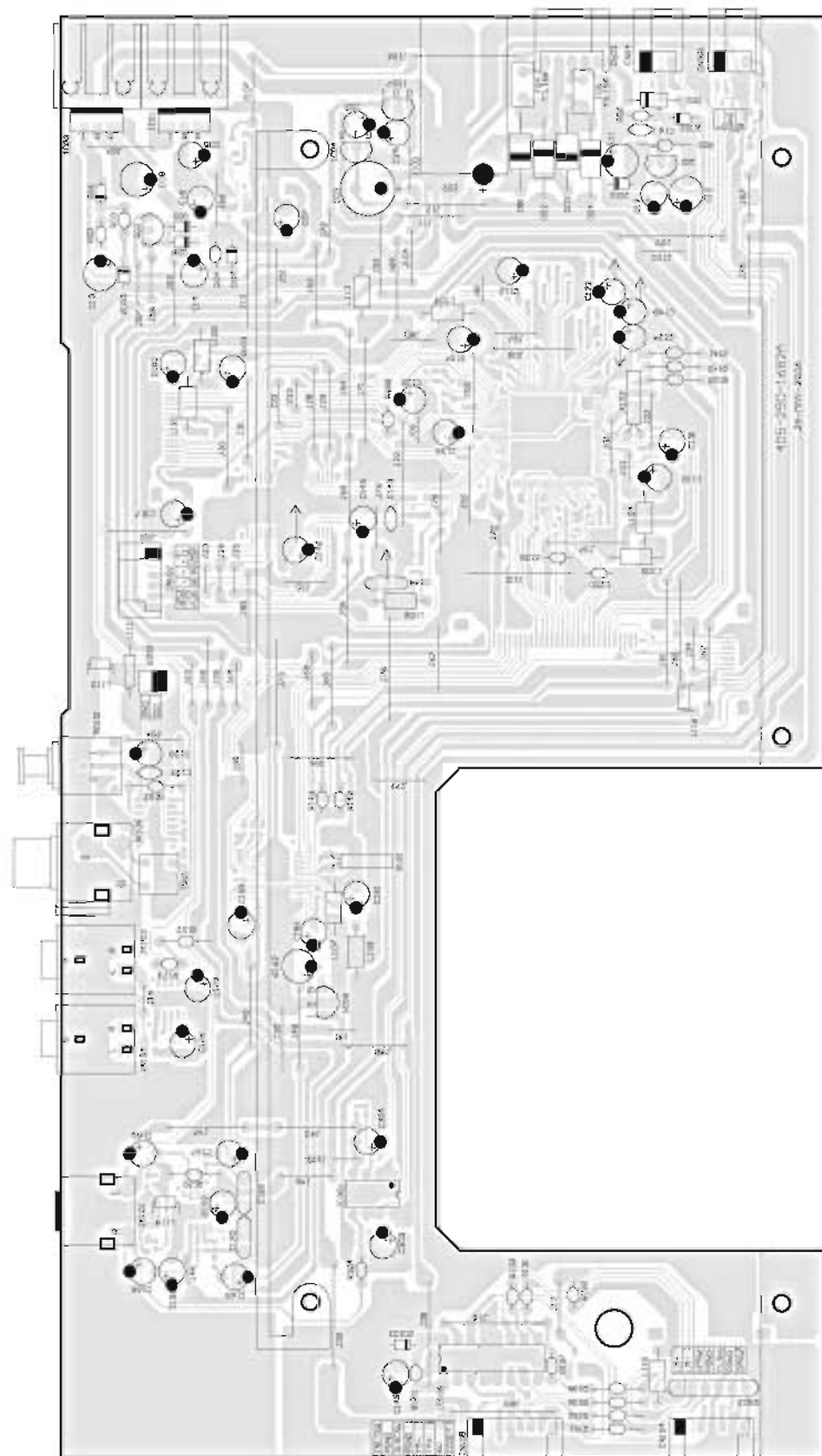

COMPONENT SIDE

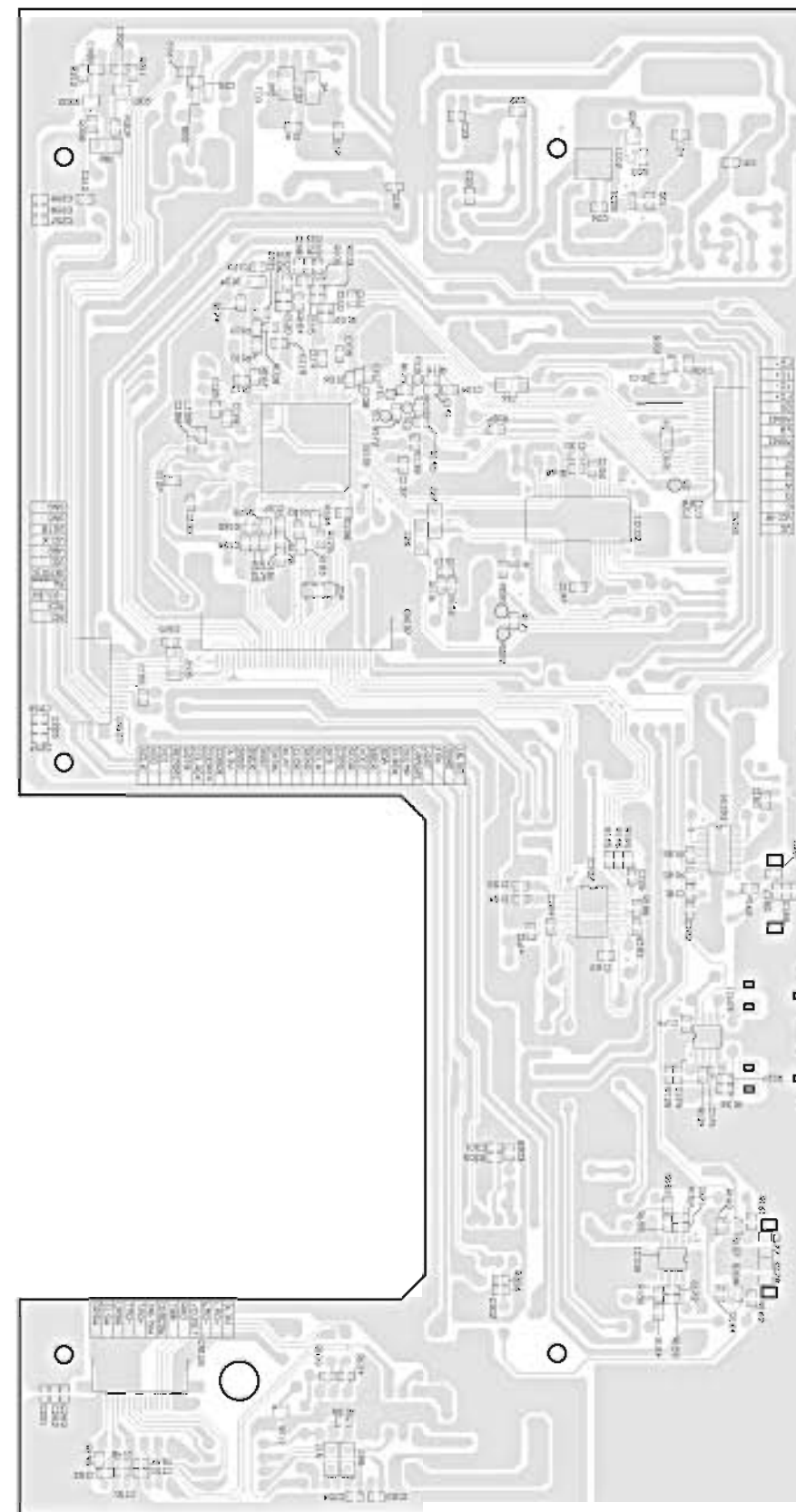

FOIL SIDE

CONTROL P.W.B. UNIT

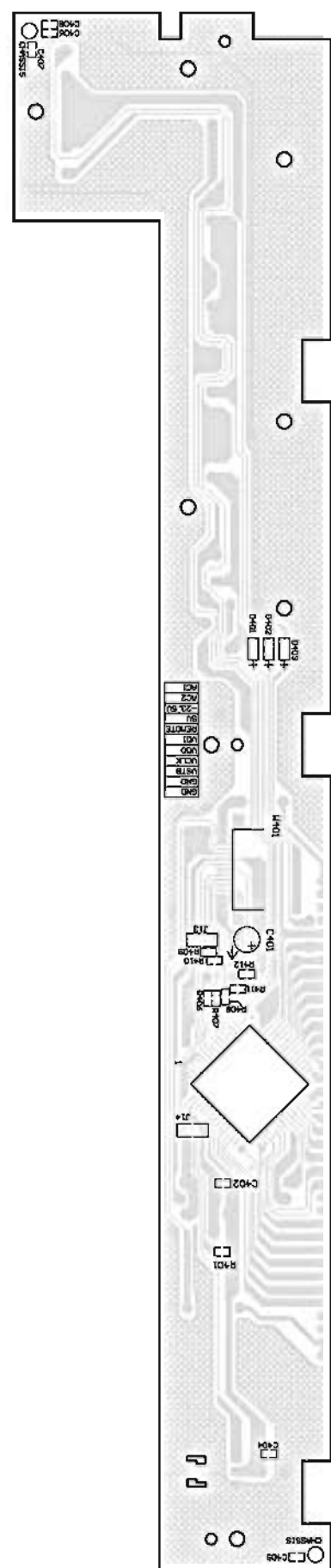
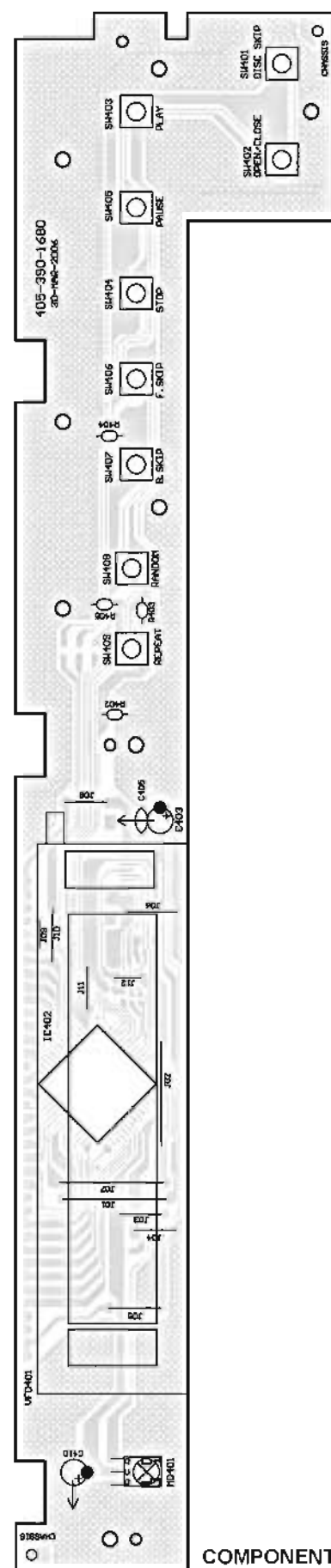

BUFFER P.W.B. UNIT

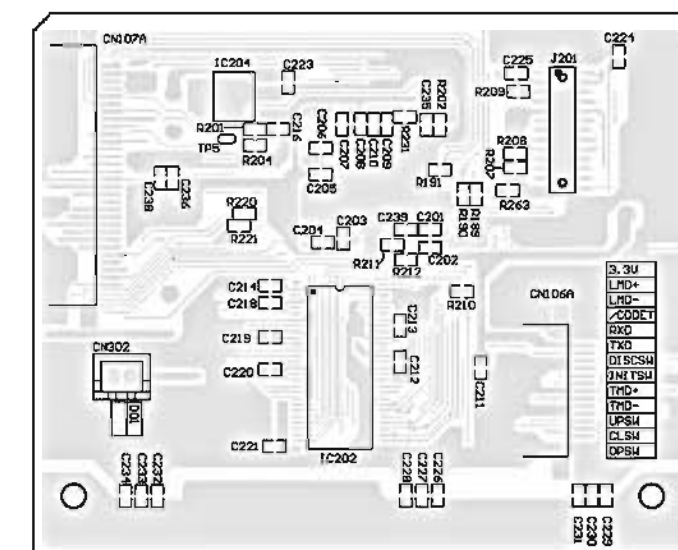
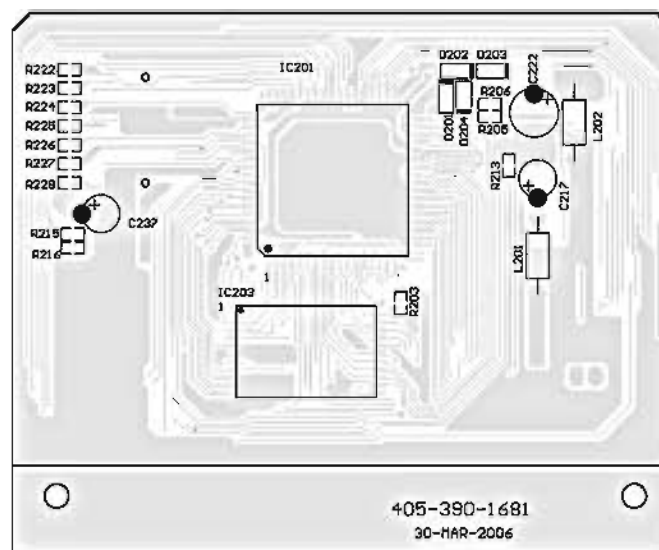

PHONE P.W.B. UNIT

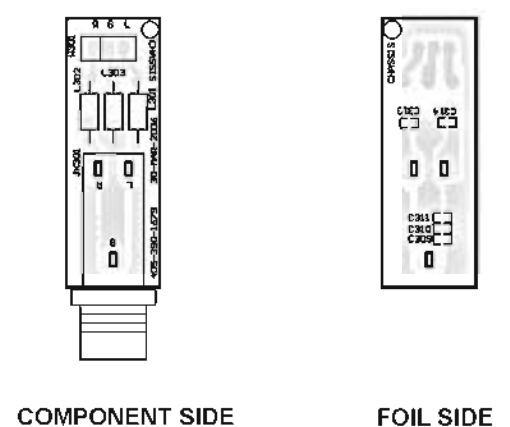

AC SOCKET P.W.B. UNIT

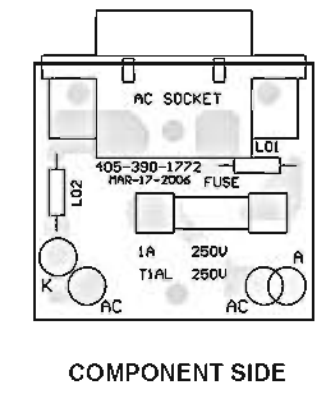

# NOTE FOR PARTS LIST

- Part indicated with the mark "nsp" are not always in stock and possibly to take a long period of time for supplying, or in some case supplying of part may be refused.
- When ordering of part, clearly indicate "1" and "I" (i) to avoid mis-supplying.
- Ordering part without stating its part number can not be supplied.
- Part indicated with the mark "★" is not illustrated in the exploded view.
- Not including General-purpose Carbon Film Resistor in the P.W.Board parts list. (Refer to the Schematic Diagram for those parts.)
- Not including General-purpose Carbon Chip Resistor in the P.W.Board parts list. (Refer to the Schematic Diagram for those parts.)

**WARNING:**  
Parts marked with this symbol  $\Delta$  have critical characteristics.  
Use ONLY replacement parts recommended by the manufacturer.

## ● Resistors

Ex.: RN 14K 2E 182 G FR  
 Type Shape Power Resist- Allowable Others  
 and per- stance error

RD	Carbon	2B	1/8W	F	±1%	P	Pulse-resistant type
RC	Composition	2E	1/4W	G	±2%	NL	Low noise type
RS	Metal oxide film	2H	1/2W	J	±5%	NB	Non-burning type
RW	Winding	3A	1W	K	±10%	FR	Fuse-resistor
RN	Metal film	3D	2W	M	±20%	F	Lead wire forming
RK	Metal mixture	3F	3W				
		3H	5W				

### \* Resistance

$\overset{1}{\text{---}} \overset{8}{\text{---}} \overset{2}{\text{---}} \Rightarrow 1800 \text{ ohm} = 1.8 \text{ kohm}$   
 Indicates number of zeros after effective number.  
 2-digit effective number.  
 • Units: ohm

$\overset{1}{\text{---}} \overset{R}{\text{---}} \overset{2}{\text{---}} \Rightarrow 1.2 \text{ ohm}$   
 1-digit effective number.  
 2-digit effective number, decimal point indicated by R.  
 • Units: ohm

## ● Capacitors

Ex.: CE 04W 1H 2R2 M BP  
 Type Shape Dielectric Capacity Allowable Others  
 and per- strength error

CE	Aluminum foil electrolytic	0J	6.3V	F	±1%	HS	High stability type
CA	Aluminum solid electrolytic	1A	10V	G	±2%	BP	Non-polar type
CS	Tantalum electrolytic	1C	16V	J	±5%	HR	Ripple-resistant type
CQ	Film	1E	25V	K	±10%	DL	For charge and discharge
CK	Ceramic	1V	35V	M	±20%	HF	For assuring high frequency
CC	Ceramic	1H	50V	Z	+80%	U	UL part
CP	Oil	2A	100V		-20%	C	CSA part
CM	Mica	2B	125V	P	+100%	W	UL-CSA type
CF	Metallized	2C	160V		-0%	F	Lead wire forming
CH	Metallized	2D	200V	C	±0.25pF		
		2E	250V	D	±0.5pF		
		2H	500V	=	Others		
		2J	630V				

### \* Capacity (electrolyte only)

$\overset{2}{\text{---}} \overset{2}{\text{---}} \overset{2}{\text{---}} \Rightarrow 2200 \mu\text{F}$   
 Indicates number of zeros after effective number.  
 2-digit effective number.  
 • Units:  $\mu\text{F}$ .

$\overset{2}{\text{---}} \overset{R}{\text{---}} \overset{2}{\text{---}} \Rightarrow 2.2 \mu\text{F}$   
 1-digit effective number.  
 2-digit effective number, decimal point indicated by R.  
 • Units:  $\mu\text{F}$ .

### \* Capacity (except electrolyte)

$\overset{2}{\text{---}} \overset{2}{\text{---}} \overset{2}{\text{---}} \Rightarrow 2200 \text{ pF} = 0.0022 \mu\text{F}$   
 (More than 2) — Indicates number of zeros after effective number.  
 2-digit effective number.  
 • Units: pF.

$\overset{2}{\text{---}} \overset{2}{\text{---}} \overset{1}{\text{---}} \Rightarrow 220 \text{ pF}$   
 (0 or 1) — Indicates number of zeros after effective number.  
 2-digit effective number.  
 • Units: pF.

• When the dielectric strength is indicated in AC, "AC" is included after the dielectric strength value.

# 部品表について

1. nsp 印の部品は常時在庫していませんので供給に長時間を要することがあります。場合によっては、供給をお断りすることがあります。
2. 部品を発注する際は特に数字の "1" と英字の "I" との区別をはっきり記入してください。
3. 部品番号を表示していない部品は供給できません。
4.  $\Delta$ 印の部品は安全上重要な部品です。交換するときは、安全および性能維持のため必ず指定の部品をご使用ください。
5. ★印のついている部品は分解図中には記載していません。
6. 汎用カーボン抵抗器は記載していません。定数は回路図を参照願います。
7. 汎用カーボンチップ抵抗器は記載していません。定数は回路図を参照願います。
8. 部品表の抵抗器、コンデンサの品名記号の読み方は表を参照してください。

## ● 抵抗器

例) RN 14K 2E 182 G FR  
 種類 形状特性 電力 抵抗値 許容差 その他

RD	カーボン	2B	1/8 W	F	±1%	P	耐バル人形
RC	固定体	2E	1/4 W	G	±2%	NL	低雑音形
RS	金属系皮膜	2H	1/2 W	J	±5%	NB	不燃形
RW	巻線	3A	1 W	K	±10%	FR	ヒューズ抵抗
RN	金属皮膜	3D	2 W	M	±20%	F	リード線成形
RK	金属混合体	3F	3 W				
		3H	5 W				

### \* 抵抗値

$\overset{18}{\text{---}} \overset{2}{\text{---}} \Rightarrow 1800 \Omega = 1.8 \text{ k}\Omega$   
 有効数字につづく0の数を表わす、  
 2桁の有効数字を表わす。  
 ; 単位は $\Omega$

$\overset{1R}{\text{---}} \overset{2}{\text{---}} \Rightarrow 1.2 \Omega$   
 1桁の有効数字を表わす。  
 2桁の有効数字で小数点はRで表わす。  
 ; 単位は $\Omega$

## ● コンデンサ

例) CE 04W 1H 2R2 M BP  
 種類 形状特性 耐圧 容量 許容差 その他

CE	アルミ箔電解	0J	6.3 V	F	±1%	HS	高安定形
CA	アルミ固体電解	1A	10 V	G	±2%	BP	無極性形
CS	タンタル電解	1C	16 V	J	±5%	HR	耐リップル形
CQ	フィルム	1E	25 V	K	±10%	DL	充放電対策用
CK	セラミック	1V	35 V	M	±20%	HF	高周波保証用
CC	セラミック	1H	50 V	Z	+80%	U	UL 部品
CP	オイル	2A	100 V		-20%	C	CSA 部品
CM	マイカ	2B	125 V	P	+100%	W	UL-CSA 部品
CF	メタライズド	2C	160 V		-0%	F	リード線成形
CH	メタライズド	2D	200 V	C	±0.25pF		
		2E	250 V	D	±0.5pF		
		2H	500 V	=	その他		
		2J	630 V				

### \* 容量値

#### ● 電解コンデンサの場合

$\overset{22}{\text{---}} \overset{2}{\text{---}} \Rightarrow 2200 \mu\text{F}$   
 有効数字につづく0の数を表わす。  
 2桁の有効数字を表わす。  
 ; 単位は $\mu\text{F}$

$\overset{2R}{\text{---}} \overset{2}{\text{---}} \Rightarrow 2.2 \mu\text{F}$   
 1桁の有効数字を表わす。  
 2桁の有効数字で小数点はRで表わす。  
 ; 単位は $\mu\text{F}$

#### ● 電解コンデンサ以外の場合

$\overset{22}{\text{---}} \overset{2}{\text{---}} \Rightarrow 2200 \text{ pF} = 0.0022 \mu\text{F}$   
 有効数字につづく0の数を表わす。  
 (0の数が2以上の場合)  
 2桁の有効数字を表わす。  
 ; 単位はpF

$\overset{22}{\text{---}} \overset{1}{\text{---}} \Rightarrow 220 \text{ pF}$   
 有効数字につづく0の数を表わす。  
 (0の数が0または1の場合)  
 2桁の有効数字を表わす。  
 ; 単位はpF

#### ● 耐圧を交流で表示する場合は、耐圧表示の次に "AC" を表示します。

## PARTS LIST OF P.W.B. UNIT

\* 本表に記載されている部品は、補修用部品のため製品に使用している部品とは一部、形状、寸法などが異なる場合があります。

\* The parts listed below are for maintenance only, might differ from the parts used in the unit in appearances or dimensions.

\* "nsp" 印の部品は常時在庫していませんので供給に長時間を要することがあります。場合によっては、供給をお断りする場合があります。

\* Part indicated with the mark "nsp" are not always in stock and possibly to take a long period of time for supplying, or in some case supplying of part may be refused.

Note: The symbols in the column "Remarks" indicate the following destinations.

BKE3 : U.S.A. & Canada model (Black)

BKE2 : Europe model (Black)

SPE2 : Europe model (Premium Silver)

### SERVO P.W.B. UNIT ASS'Y

Ref. No.	nsp	Part No.	Part Name	Remarks	Q'ty	New
<b>SEMICONDUCTORS GROUP</b>						
IC01		00D 958 0040 303	IC 7805		417-KC730-123	1
IC02		00D 958 0073 901	IC (BA033FP-E2)		417-CTB200-500	1
IC03		00D 941 0045 407	IC (BA08T 3PIN)		417-HMD5000-282	1
IC04		00D 941 0045 504	IC (NJM-79L08A)		417-KT100-024	1
IC05		00D 941 0045 601	IC (BD4745G/BD4745G-TR)		417-HDJ2000-503	1
IC06		00D 958 0016 308	IC (LM78L05)		417-PMSE1-161	1
IC07		00D 941 0045 708	IC (NJM-78L08A)		417-KT100-023	1
IC101		00D 941 0045 805	IC (CXD3059)		417-385-760	1
IC102		00D 941 0045 902	IC (BA6392FPE2)		417-CDN24-340	1
IC103		00D 958 0076 209	IC (74HC04/74HC04DT)		417-DCM370E3-378	1
IC104		00D 941 0046 008	IC (SP232ACP,16PIN)	for 390BKE3	417-MP3-430	1
IC105		00D 262 2580 906	IC (CXA1511M)		417-DCM370E3-329	1
IC106		00D 958 0015 202	IC (LA6531-E,DIP16F)		417-KC220-045	1
IC107		00D 262 2901 909	IC (PCM1732)	for 390BKE3	417-DCM370X-328	1
IC107		00D 262 2490 902	IC (PCM1716E)	for 290BKE3/27BKE3/ 500AEBKE2/500AESPE2	417-DCM270X-327A	1
IC108		00D 941 0046 105	IC (BA15218F/BA15218FE2)		417-QMX2-167	1
IC301		00D 958 0073 804	INTEGRATED CIRCUIT (NJM-4556AD)		417-3113-018	1
Q01		00D 958 0015 901	TRANSISTOR (2SB1010(R))		416-1360S-017	1
Q02		00D 941 0046 202	TRANSISTOR (DTA124TS/2SA1589/DTA124TSATP)		416-KE200S-024	1
Q03		00D 958 7057 409	CHIP TRANSISTOR (2SC2412KT146R)		416-CDN88-051	1
Q04		00D 958 7057 506	TRANSISTOR (DTA124TS/2SA1589/DTA124TSATP)		416-CTB200-178	1
Q05		00D 941 0046 503	TRANSISTOR (DTC124EKAT146/DTC124EKA)		416-CDN88-044	1
Q101		00D 941 0046 309	TRANSISTOR (2SA1037AKT146R/2SA1037AKR)		416-CDN88-045	1
Q107,108		00D 941 0046 406	TRANSISTOR (2SC4695-TB-E)		416-DAIA-273	2
Q111		00D 941 0046 503	TRANSISTOR (DTC124EKAT146/DTC124EKA)		416-CDN88-044	1
Q301,302		00D 941 0046 600	TRANSISTOR (2SC4695-TB-E)		416-DAIA-273	2
D01-04		00D 941 0046 707	RECTIFYING DIODE (1N5392)		414-HT7016-031	4
D05		00D 941 0046 804	DIODE (1N4002/1N4002TA)		414-DV300-5014	1
D06-09		00D 958 0042 806	SWITCHING DIODE (1SS132/133)		414-3113-005	4
D101		00D 941 0046 901	SWITCHING DIODE (1SS355)		414-CD1000-075	1
D104		00D 941 0046 901	SWITCHING DIODE (1SS355)		414-CD1000-075	1
ZD01		00D 941 0050 900	ZENER DIODE (MTZJ27-C)		414-390-218	1
ZD02		00D 941 0047 007	ZENER DIODE (MTZJ6.8-C)		414-KC720-016	1
ZD03		00D 958 0075 103	ZENER DIODE (MTZJ5.1-B)		414-HDJ200-056	1
ZD103		90M -HD 3023 30R	ZENER DIODE (MTZJ4.7-B)		414-MDS930VS-102	1
<b>RESISTORS GROUP</b>						
R01		-	CHIP RESISTOR (10K OHM,1/10W)		412-CDVD2001-534	1
R02		-	CARBON FILM RESISTOR (220 OHM,1/6W)		412-3113-058	1
R03		-	CARBON FILM RESISTOR (470K OHM,1/6W)		412-3113-056	1
R04		-	CARBON FILM RESISTOR (100K OHM,1/6W)		412-3113-047	1
R05		-	CARBON FILM RESISTOR (10K OHM,1/4W)		412-3113-068	1



Ref. No.	nsp	Part No.	Part Name	Remarks		Q'ty	New
R06		-	CARBON FILM RESISTOR (4.7K OHM,1/6W)		412-3113-055	1	
R101		-	CHIP RESISTOR (22 OHM,1/10W)		412-CDVD2001-554	1	
R102		-	CHIP RESISTOR (15K OHM,1/10W)		412-007USB-687	1	
R103		-	CHIP RESISTOR (470K OHM,1/10W)		412-007USB-707	1	
R104		-	CHIP RESISTOR (10K OHM,1/10W)		412-CDVD2001-534	1	
R105		-	CHIP RESISTOR (100K OHM,1/10W)		412-CDVD2001-537	1	
R106		-	CHIP RESISTOR (1M OHM,1/10W)		412-CDVD2001-546	1	
R107		-	CHIP RESISTOR (470K OHM,1/10W)		412-007USB-707	1	
R108		-	CHIP RESISTOR (3.3K OHM,1/10W)		412-007USB-699	1	
R109		-	CHIP RESISTOR (1K OHM,1/10W)		412-CDVD2001-540	1	
R110		-	CHIP RESISTOR (4.7K OHM,1/10W)		412-CDVD2001-523	1	
R112		-	CHIP RESISTOR (470K OHM,1/10W)		412-007USB-707	1	
R115,116		-	CHIP RESISTOR (15K OHM,1/10W)		412-007USB-687	2	
R117,118		-	CHIP RESISTOR (10K OHM,1/10W)		412-CDVD2001-534	1	
R119		-	CHIP RESISTOR (150K OHM,1/10W)		412-007USB-688	1	
R120		-	CHIP RESISTOR (47K OHM,1/10W)		412-CDVD2001-532	1	
R122		-	CARBON FILM RESISTOR (47 OHM,1/6W)		412-KC220-133	1	
R123		-	CARBON FILM RESISTOR (200K OHM,1/6W)		412-KC220-129	1	
R124		-	CHIP RESISTOR (470 OHM,1/10W)		412-CDVD2001-545	1	
R125		-	CHIP RESISTOR (1K OHM,1/10W)		412-CDVD2001-540	1	
R126		-	CHIP RESISTOR (39K OHM,1/10W)		412-007USB-706	1	
R127		-	CHIP RESISTOR (220 OHM,1/10W)		412-CDVD2001-521	1	
R130		-	CARBON FILM RESISTOR (1.8K OHM,1/6W)		412-3113-075	1	
R131,132		-	CARBON FILM RESISTOR (15K OHM,1/6W)		412-3113-053	2	
R133,134		-	CHIP RESISTOR (20K OHM,1/10W)		412-DCM280-726	2	
R135-137		-	CARBON FILM RESISTOR (15K OHM,1/6W)		412-3113-053	3	
R138		-	CHIP RESISTOR (15K OHM,1/10W)		412-007USB-687	1	
R139-141		-	CARBON FILM RESISTOR (220 OHM,1/6W)		412-3113-058	3	
R142,143		-	CARBON FILM RESISTOR (100 OHM,1/6W)		412-3113-060	2	
R144		-	CARBON FILM RESISTOR (1K OHM,1/6W)	for 390BKE3	412-3113-078	1	
R145,146		-	CHIP RESISTOR (220 OHM,1/10W)		412-CDVD2001-521	2	
R147-149		-	CHIP RESISTOR (330 OHM,1/10W)		412-900-983	3	
R150,151		-	CARBON FILM RESISTOR (330 OHM,1/6W)		412-KM300-118	2	
R152		-	CARBON FILM RESISTOR (1K OHM,1/6W)		412-3113-078	1	
R153,154		-	CHIP RESISTOR (5.1K OHM,1/10W)	for 390BKE3	412-007USB-673	2	
R153,154		-	CHIP RESISTOR (6.2K OHM,1/10W)	for 290BKE3/27BKE3/ 500AEBKE2/500AESPE2	412-900-985	2	
R155,156		-	CHIP RESISTOR (1.5K OHM,1/10W)	for 390BKE3	412-CDVD2001-550	2	
R155,156		-	CHIP RESISTOR (1K OHM,1/10W)	for 290BKE3/27BKE3/ 500AEBKE2/500AESPE2	412-CDVD2001-540	2	
R157,158		-	CHIP RESISTOR (22K OHM,1/10W)	for 390BKE3	412-007USB-704	2	
R157,158		-	CHIP RESISTOR (13K OHM,1/10W)	for 290BKE3/27BKE3/ 500AEBKE2/500AESPE2	412-900-981	2	
R160		-	CHIP RESISTOR (0 OHM,1/10W)		412-CDVD2001-552	1	
R161,162		-	CHIP RESISTOR (1K OHM,1/10W)		412-CDVD2001-540	2	
R163,164		-	CHIP RESISTOR (2.7K OHM,1/10W)		412-007USB-677	2	
R165		-	CHIP RESISTOR (22 OHM,1/10W)		412-CDVD2001-554	1	
R166		-	CHIP RESISTOR (68 OHM,1/10W)		412-900-1016	1	
R167		-	CHIP RESISTOR (0 OHM,1/10W)		412-CDVD2001-552	1	
R168		-	CHIP RESISTOR (4.7 OHM,1/10W)		412-007USB-676	1	
R170		-	CARBON FILM RESISTOR (100K OHM,1/6W)		412-3113-047	1	
R171-173		-	CHIP RESISTOR (0 OHM,1/10W)		412-CDVD2001-552	3	
R174		-	CHIP RESISTOR (22 OHM,1/10W)		412-CDVD2001-554	1	
R175		-	CHIP RESISTOR (100 OHM,1/10W)		412-CDVD2001-530	1	
R178,179		-	CHIP RESISTOR (100 OHM,1/10W)		412-CDVD2001-530	2	
R181-184		-	CHIP RESISTOR (100 OHM,1/10W)		412-CDVD2001-530	4	
R185,186		-	CHIP RESISTOR (1K OHM,1/10W)		412-CDVD2001-540	2	
R187		-	CHIP RESISTOR (0 OHM,1/10W)		412-CDVD2001-552	1	

Ref. No.	nsp	Part No.	Part Name	Remarks		Q'ty	New
R192		-	CARBON FILM RESISTOR (4.7K OHM,1/6W)		412-3113-055	1	
R195		-	CHIP RESISTOR (1M OHM,1/10W)		412-CDVD2001-546	1	
R303		-	CHIP RESISTOR (18K OHM,1/10W)		412-007USB-703	1	
R304		-	CARBON FILM RESISTOR (18K OHM,1/6W)		412-3113-061	1	
R305,306		-	CHIP RESISTOR (15K OHM,1/10W)		412-007USB-687	2	
R307,308		-	CHIP RESISTOR (3.3K OHM,1/10W)		412-007USB-699	2	
R311,312		-	CHIP RESISTOR (39 OHM,1/10W)		412-DCM280-755	2	
RB12		-	THICK FILM RESISTOR NETWORKS(4.7k OHM)		412-DV300-5139	1	
<b>CAPACITORS GROUP</b>							
C02		-	ELEC.CAPACITOR (4700uF/16V)		413-DV300-293	1	
C03		-	ELEC.CAPACITOR (470uF/16V)		413-HT8015-164	1	
C04		-	CHIP CAPACITOR (0.1uF/50V)		413-DCM280-773	1	
C05		-	ELEC.CAPACITOR (100uF/10V)		413-HMA2200-5017	1	
C06		-	CHIP CAPACITOR (0.1u/50V)		413-DCM280-773	1	
C07		-	ELEC.CAPACITOR (100uF/10V)		413-HMA2200-5017	1	
C08		-	ELEC.CAPACITOR (220uF/10V)		413-HT801K-192	1	
C09		-	ELEC.CAPACITOR (100uF/10V)		413-HMA2200-5017	1	
C10		-	ELEC.CAPACITOR (100uF/50V)		413-HC1421FR-277	1	
C11		-	ELEC.CAPACITOR (100uF/35V)		413-HMD5000-356	1	
C12		-	ELEC.CAPACITOR (10uF/35V)		413-810-919	1	
C13		-	ELEC.CAPACITOR (220uF/16V)		413-RMX30-883	1	
C14		-	ELEC.CAPACITOR (10uF/25V)		413-SPPW3-235	1	
C15		-	ELEC.CAPACITOR (2.2uF/50V)		413-DV300-5156	1	
C16		-	CERAMIC CAPACITOR (0.1uF/50V)		413-3113-035	1	
C17-22		-	CHIP CAPACITOR (0.1uF/50V)		413-DCM280-773	6	
C23		-	CHIP CAPACITOR (0.1uF/50V)		413-DCM280-773	1	
C24		-	ELEC.CAPACITOR (100uF/10V)		413-HMA2200-5017	1	
C25,26		-	CHIP CAPACITOR (1000pF/50V)		413-DCM280-768	2	
C101		-	CHIP CAPACITOR (0.1uF/50V)		413-DCM280-773	1	
C102,103		-	ELEC.CAPACITOR (100uF/10V)		413-HMA2200-5017	2	
C104		-	CHIP CAPACITOR (0.1uF/50V)		413-DCM280-773	1	
C105		-	ELEC.CAPACITOR (100uF/10V)		413-HMA2200-5017	1	
C107		-	ELEC.CAPACITOR (22uF/16V)		413-SPPW3-236	1	
C108-111		-	CHIP CAPACITOR (0.1uF/50V)		413-DCM280-773	4	
C112		-	ELEC.CAPACITOR (22uF/16V)		413-SPPW3-236	1	
C113		-	CHIP CAPACITOR (0.1uF/50V)		413-DCM280-773	1	
C114		-	CHIP CAPACITOR (680pF/50V)		413-CDVD2003-719	1	
C115		-	CHIP CAPACITOR (100pF/50V)		413-DCM280-767	1	
C116		-	CHIP CAPACITOR (0.01uF/50V)		413-DCM280-771	1	
C117		-	CHIP CAPACITOR (0.1uF/50V)		413-DCM280-773	1	
C118		-	CHIP CAPACITOR (1000pF/50V)		413-DCM280-768	1	
C119		-	CHIP CAPACITOR (1500pF/50V)		413-DCM280-769	1	
C120,121		-	CHIP CAPACITOR (0.1uF/50V)		413-DCM280-773	2	
C122		-	ELEC.CAPACITOR (22uF/16V)		413-SPPW3-236	1	
C123		-	CHIP CAPACITOR (0.1uF/50V)		413-DCM280-773	1	
C124		-	ELEC.CAPACITOR (1uF/50V)		413-SPPW3-234	1	
C125-127		-	CHIP CAPACITOR (0.1uF/50V)		413-DCM280-773	3	
C128		-	ELEC.CAPACITOR (10uF/25V)		413-SPPW3-235	1	
C129		-	CERAMIC CAPACITOR (0.1uF/50V)		413-3113-035	1	
C130		-	CHIP CAPACITOR (0.1uF/50V)		413-DCM280-773	1	
C131,132		-	ELEC.CAPACITOR (10uF/25V)		413-SPPW3-235	2	
C133,134		-	CHIP CAPACITOR (0.1uF/50V)		413-DCM280-773	2	
C135		-	C.CB(Y5P) AXIAL (0.1uF/50V)		413-HF6011E-563	1	
C136-138		-	CHIP CAPACITOR (0.1uF/50V)		413-DCM280-773	3	

Ref. No.	nsp	Part No.	Part Name	Remarks		Q'ty	New
C139		-	ELEC.CAPACITOR (22uF/16V)		413-SPPW3-236	1	
C140,141		-	CHIP CAPACITOR (220pF/50V)		413-007USB-787	2	
C143		-	CERAMIC CAPACITOR (0.1uF/50V)		413-3113-035	1	
C144		-	POLYESTER CAPACITOR (0.022uF/50V)		413-KT300-101	1	
C145		-	ELEC.CAPACITOR (100uF/10V)		413-HMA2200-5017	1	
C146		-	ELEC.CAPACITOR (220uF/10V)		413-HT801K-192	1	
C147		-	CHIP CAPACITOR (0.1uF/50V)		413-DCM280-773	1	
C148		-	ELEC.CAPACITOR (100uF/10V)		413-HMA2200-5017	1	
C149		-	ELEC.CAPACITOR (100uF/16V)		413-HT801K-193	1	
C150-154		-	CHIP CAPACITOR (0.01uF/50V)		413-DCM280-771	5	
C155		-	ELEC.CAPACITOR (1uF/50V)	for 390BKE3	413-SPPW3-234	1	
C156		-	CHIP CAPACITOR (0.1uF/50V)	for 390BKE3	413-DCM280-773	1	
C157-160		-	ELEC.CAPACITOR (1uF/50V)	for 390BKE3	413-SPPW3-234	4	
C161		-	ELEC.CAPACITOR (10uF/25V)		413-SPPW3-235	1	
C162		-	ELEC.CAPACITOR (100uF/10V)		413-HMA2200-5017	1	
C163,164		-	CHIP CAPACITOR (0.1uF/50V)		413-DCM280-773	2	
C165,166		-	ELEC.CAPACITOR (10uF/25V)		413-SPPW3-235	2	
C167,168		-	ELEC.CAPACITOR (33uF/16V)		413-HDJ201-350	2	
C169,170		-	POLYESTER CAPACITOR (0.0039uF/50V)	for 390BKE3	413-HT8023K-179	2	
C169,170		-	POLYESTER CAPACITOR (0.0047uF/50V)	for 290BKE3/27BKE3/ 500AEBKE2/500AESPE2	413-HT8015-159	2	
C171,172		-	CHIP CAPACITOR (220pF/50V)	for 390BKE3	413-007USB-787	2	
C171,172		-	CHIP CAPACITOR (300pF/50V)	for 290BKE3/27BKE3/ 500AEBKE2/500AESPE2	413-CR701-5175-787	2	
C173		-	ELEC.CAPACITOR (22uF/16V)		413-SPPW3-236	1	
C174		-	CHIP CAPACITOR (0.1uF/50V)		413-DCM280-773	1	
C175		-	CHIP CAPACITOR (0.01uF/50V)		413-DCM280-771	1	
C176		-	ELEC.CAPACITOR (1uF/50V)		413-SPPW3-234	1	
C177,178		-	CHIP CAPACITOR (1000pF/50V)		413-DCM280-768	2	
C179		-	CHIP CAPACITOR (0.01uF/50V)		413-DCM280-771	1	
C180,181		-	CHIP CAPACITOR (0.1uF/50V)		413-DCM280-773	2	
C182		-	CHIP CAPACITOR (220pF/50V)		413-007USB-787	1	
C183,184		-	CHIP CAPACITOR (0.1uF/50V)		413-DCM280-773	2	
C185,186		-	ELEC.CAPACITOR (10uF/25V)		413-SPPW3-235	2	
C187		-	CHIP CAPACITOR (47pF/50V)		413-007USB-784	1	
C188		-	CHIP CAPACITOR (0.01uF/50V)		413-DCM280-771	1	
C189		-	CHIP CAPACITOR (0.1uF/50V)		413-DCM280-773	1	
C190		-	CHIP CAPACITOR (1000pF/50V)		413-DCM280-768	1	
C191,192		-	ELEC.CAPACITOR (100uF/10V)		413-HMA2200-5017	2	
C193		-	CHIP CAPACITOR (56pF/50V)	for 390BKE3	413-900-929	1	
C193		-	CHIP CAPACITOR (68pF/50V)	for 290BKE3/27BKE3/ 500AEBKE2/500AESPE2	413-DCM280-766	1	
C194		-	CHIP CAPACITOR (47pF/50V)	for 390BKE3	413-007USB-784	1	
C194		-	CHIP CAPACITOR (68pF/50V)	for 290BKE3/27BKE3/ 500AEBKE2/500AESPE2	413-DCM280-766	1	
C195		-	CHIP CAPACITOR (0.1uF/50V)		413-DCM280-773	1	
C196		-	CHIP CAPACITOR (0.33uF/16V)		413-007USB-782	1	
C197		-	CHIP CAPACITOR (0.1uF/50V)		413-DCM280-773	1	
C199		-	CHIP CAPACITOR (0.1uF/50V)		413-DCM280-773	1	
C200		-	C.CB(Y5P) AXIAL (0.1uF/50V)		413-HF6011E-563	1	
C251		-	CHIP CAPACITOR (0.01uF/50V)		413-DCM280-771	1	
C252		-	CHIP CAPACITOR (0.1uF/50V)		413-DCM280-773	1	
C254		-	CHIP CAPACITOR (0.01uF/50V)		413-DCM280-771	1	
C255		-	CHIP CAPACITOR (0.1uF/50V)		413-DCM280-773	1	
C257		-	CHIP CAPACITOR (0.01uF/50V)		413-DCM280-771	1	
C258		-	CHIP CAPACITOR (0.1uF/50V)		413-DCM280-773	1	
C301,302		-	CHIP CAPACITOR (100pF/50V)		413-DCM280-767	2	
C303,304		-	ELEC.CAPACITOR (100uF/10V)		413-HMA2200-5017	2	

Ref. No.	nsp	Part No.	Part Name	Remarks		Q'ty	New
C307,308		-	CHIP CAPACITOR (1500pF/50V)		413-DCM280-769	2	
C312		-	CHIP CAPACITOR (0.1uF/50V)		413-DCM280-773	1	
C315		-	CHIP CAPACITOR (39pF/50V)		413-390-987	1	
C316		-	CHIP CAPACITOR (0.1uF/50V)		413-DCM280-773	1	
C317		-	ELEC.CAPACITOR (100uF/10V)		413-HMA2200-5017	1	
<b>OTHER PARTS GROUP</b>							
CN03	nsp	00D 941 0047 104	5P SOCKET		404-SPPW3-513	1	
CN04	nsp	00D 941 0047 201	3P SOCKET		404-KMD3500-609	1	
CN101		00D 941 0047 308	16P FFC CONNECTOR		404-HV3423K-583	1	
CN102	nsp	00D 958 0013 505	6P SOCKET		404-90V1-101	1	
CN103		00D 941 0047 405	11P FFC CONNECTOR		404-300-1914	1	*
CN104	nsp	00D 958 0041 506	7P SOCKET(S7B-PH-K,JST)		404-HMD5000-785	1	
CN105	nsp	00D 941 0047 502	8P SOCKET		404-DV300-506	1	
CN106		00D 941 0047 609	13P FFC CONNECTOR		404-385-2086	1	*
CN107		00D 941 0047 706	30P FFC CONNECTOR		404-385-2088	1	*
CN301	nsp	00D 941 0047 803	3P SOCKET		404-DJ100-1077	1	
J04		-	CHIP RESISTOR (0 OHM,1/8W)		412-DJ3000-414	1	
J15		-	CHIP RESISTOR (0 OHM,1/8W)		412-DJ3000-414	1	
J26,27		-	CHIP RESISTOR (0 OHM,1/8W)		412-DJ3000-414	2	
J36		-	CHIP RESISTOR (0 OHM,1/8W)		412-DJ3000-414	1	
J88		-	CHIP RESISTOR (0 OHM,1/8W)		412-DJ3000-414	1	
J98		-	CHIP RESISTOR (0 OHM,1/8W)		412-DJ3000-414	1	
J105		-	CHIP RESISTOR (0 OHM,1/8W)		412-DJ3000-414	1	
JK101		00D 941 0047 900	2P RCA JACK (RJ-1060-10-0300A)		420-R1C-173A	1	
JK102		00D 941 0048 006	SIGNAL JACK (D-SMB,205A09FGTBB3)	for 390BKE3	420-MP3-104	1	
JK103,104		00D 958 0074 706	HEADPHONE JACK (JY-3535-01-030G)		420-HMDV3360K-5014	2	
JK106		00D 958 0074 609	1P RCA JACK (RJ-1081-31-0341A)		420-HDJ2650-097A	1	
L101-106		00D 958 0016 900	BEAD CORE (86-019-A)		415-HV3500K-090	6	
L109		00D 958 0016 900	BEAD CORE (86-019-A)		415-HV3500K-090	1	
L110		00D 958 0016 900	BEAD CORE (86-019-A)	for 390BKE3	415-HV3500K-090	1	
L111		00D 958 0017 006	INDUCTOR (10uH)		415-MPG100-047	1	
L112		00D 941 0048 103	BEAD (RH03506BT-B)		415-DMC370E3-134	1	
L113		00D 958 0016 900	BEAD CORE (86-019-A)		415-HV3500K-090	1	
L114		00D 941 0048 200	BEAD (RH03506BT-B)		415-DMC370E3-134	1	
L115		00D 958 0016 900	BEAD CORE (86-019-A)		415-HV3500K-090	1	
L116		00D 941 0048 307	BEAD (RH03506BT-B)		415-DMC370E3-134	1	
MD101		00D 941 0048 404	3P OPTICAL TRANSMITTING CONNECTOR		420-900-205	1	
T901		00D 958 0020 705	COIL (P-7GB)		415-RCC955A-091	1	
W302		-	3P CONNECTOR WIRE (L=160)		404-390-2167	1	*
X101		00D 958 0015 600	CRYSTAL (16.9344MHz)		427-KC710-019	1	
IC01		-	HEAT SINK		425-390-093	1	*
IC03		-	HEAT SINK		425-P22-070	1	
FUSE02,03		00D 941 0051 103	CHIP FUSE	for 390BKE3/290BKE3/ 27BKE3	422-MH2-076	2	*
FUSE04,05		00D 941 0051 200	FUSE T3.15/250V type:392	for 500AEBKE2/500AESPE2	422-500E2-088	2	*

## CONTROL P.W.B. UNIT ASS'Y

Ref. No.	nsp	Part No.	Part Name	Remarks		Q'ty	New
<b>SEMICONDUCTORS GROUP</b>							
IC401		00D 941 0048 501	IC(VFD DRIVER IC UPD1631GC-AB6)		417-HV3500K-250A	1	
D401-403		00D 941 0048 608	SWITCHING DIODE (1SS355)		414-CD1000-075	3	
<b>RESISTORS GROUP</b>							
R401		-	CHIP RESISTOR (56K OHM,1/10W)		412-007USB-674	1	
R402-405		-	CARBON FILM RESISTOR (10K OHM,1/6W)		412-3113-068	4	
R406-408		-	CHIP RESISTOR (1.5K OHM,1/10W)		412-CDVD2001-550	3	
R409-411		-	CHIP RESISTOR (10K OHM,1/10W)		412-CDVD2001-534	3	
R412		-	CHIP RESISTOR (1K OHM,1/10W)		412-CDVD2001-540	1	
<b>CAPACITORS GROUP</b>							
C401		-	ELEC.CAPACITOR (100uF/10V)		413-HMA2200-5017	1	
C402		-	CHIP CAPACITOR (0.1uF/50V)		413-DCM280-773	1	
C403		-	ELEC.CAPACITOR (10uF/35V)		413-810-919	1	
C404		-	CHIP CAPACITOR (0.1uF/50V)		413-DCM280-773	1	
C405		-	CERAMIC CAPACITOR (0.1uF/50V)		413-3113-035	1	
C406		-	CHIP CAPACITOR (100pF/50V)		413-DCM280-767	1	
C407		-	CHIP CAPACITOR (0.1uF/50V)		413-DCM280-773	1	
C409		-	CHIP CAPACITOR (0.1uF/50V)		413-DCM280-773	1	
C410		-	ELEC.CAPACITOR (47uF/10V)		413-810-920	1	
<b>OTHER PARTS GROUP</b>							
J13,J14		-	CHIP RESISTOR (0 OHM,1/8W)		412-DJ3000-414	2	
W401		00D 941 0048 705	11P 1.0 FFC CONNECTOR		404-300-1914	1	*
VFD401		00D 941 0048 802	VFD (HNA-07MM26)		410-385-290	1	*
MD401		00D 449 0303 004	RECEIVER(GP1UM271XK)		417-390-777	1	
SW401-409		00D 958 0018 306	TACT SW(H=5)		403-DCM270X-101A	9	
CHASSIS		-	1P GROUND WIRE(L=270)		406-390-840	1	*
		-	GROUND PLATE	for 390BKE3/290BKE3	300-390-1399	1	*
		-	GROUND PLATE	for 27BKE3/500AEBKE2/ 500AESPE2	300-500AE-1400	1	*

## BUFFER P.W.B. UNIT ASS'Y

Ref. No.	nsp	Part No.	Part Name	Remarks		Q'ty	New
<b>SEMICONDUCTORS GROUP</b>							
IC201		00D 941 0048 909	IC(SCF5249LPV120/SCF5249LAG120)		417-MCDS4-736	1	
IC202		00D 941 0049 005	IC(K4S641632E-TC/K4S641632F/ K4S641632H-TC75)		417-CDN88-501	1	
IC203		00D 941 0049 102	BUFFER IC ASS'Y (M29W800DB70N6Y)	for 390BKE3/290BKE3/27BKE3	704-390-6144	1	*
IC203		00D 941 0053 004	BUFFER IC ASS'Y (M29W800DB70N6Y)	for 500AEBKE2/500AESPE2	704-C200-6660	1	*
IC204		00D 941 0049 209	IC(BA18BC0FP-E2)		417-MCDS4-737	1	
<b>RESISTORS GROUP</b>							
R189,190		-	CHIP RESISTOR (220K OHM,1/10W)		412-CDVD2001-521	2	
R191		-	CHIP RESISTOR (47K OHM,1/10W)		412-CDVD2001-532	1	
R201		-	CHIP RESISTOR (220K OHM,1/10W)		412-CDVD2001-521	1	
R204-206		-	CHIP RESISTOR (220K OHM,1/10W)		412-CDVD2001-521	3	
R215,216		-	CHIP RESISTOR (4.7K OHM,1/10W)		412-CDVD2001-523	2	
R202,203		-	CHIP RESISTOR (4.7K OHM,1/10W)		412-CDVD2001-523	2	
R210,211		-	CHIP RESISTOR (100 OHM,1/10W)		412-CDVD2001-530	2	
R213		-	CHIP RESISTOR (100 OHM,1/10W)		412-CDVD2001-530	1	
R220,221		-	CHIP RESISTOR (100 OHM,1/10W)		412-CDVD2001-530	2	
R207,208		-	CHIP RESISTOR (0 OHM,1/10W)		412-CDVD2001-552	2	
R222-228		-	CHIP RESISTOR (0 OHM,1/10W)		412-CDVD2001-552	7	
R231		-	CHIP RESISTOR (10K OHM,1/10W)		412-CDVD2001-534	1	
R236		-	CHIP RESISTOR (10K OHM,1/10W)		412-CDVD2001-534	1	
<b>CAPACITORS GROUP</b>							
C201-214		-	CHIP CAPACITOR (0.1uF/50V)		413-DCM280-773	14	
C216		-	CHIP CAPACITOR (0.1uF/50V)		413-DCM280-773	1	
C217		-	ELEC.CAPACITOR (100uF/10V)		413-HMA2200-5017	1	
C218-221		-	CHIP CAPACITOR (0.1uF/50V)		413-DCM280-773	4	
C222		-	ELEC.CAPACITOR (220uF/10V)		413-HT801K-192	1	
C223		-	CHIP CAPACITOR (0.1uF/50V)		413-DCM280-773	1	
C226		-	CHIP CAPACITOR (0.01uF/50V)		413-DCM280-771	1	
C227		-	CHIP CAPACITOR (0.1uF/50V)		413-DCM280-773	1	
C229		-	CHIP CAPACITOR (0.01uF/50V)		413-DCM280-771	1	
C230		-	CHIP CAPACITOR (0.1uF/50V)		413-DCM280-773	1	
C232		-	CHIP CAPACITOR (0.01uF/50V)		413-DCM280-771	1	
C233		-	CHIP CAPACITOR (0.1uF/50V)		413-DCM280-773	1	
C235,236		-	CHIP CAPACITOR (0.1uF/50V)		413-DCM280-773	2	
C237		-	ELEC.CAPACITOR (100uF/10V)		413-HMA2200-5017	1	
C238		-	CHIP CAPACITOR (150pF/50V)		413-900-931	1	
C239		-	CHIP CAPACITOR (39pF/50V)		413-390-987	1	
<b>OTHER PARTS GROUP</b>							
CN106A		00D 941 0049 306	13P FFC CONNECTOR		404-385-2086	1	*
CN107A		00D 941 0049 403	30P FFC CONNECTOR		404-385-2088	1	*
CN302	nsp	00D 941 0049 500	2P SOCKET		404-KMD1500-608	1	
L201,202		-	BEAD CORE (RH03506ST-B,65Ω/100MHz)		415-HV3500K-090	1	
		-	CUSHON		612-390-235	1	*



## PHONE P.W.B. UNIT ASS'Y

Ref. No.	nsp	Part No.	Part Name	Remarks		Q'ty	New
<b>CAPACITORS GROUP</b>							
C309		-	CHIP CAPACITOR (0.1ÉpF/50V)		413-DCM280-773	1	
C313,314		-	CHIP CAPACITOR (470pF/50V)		413-007USB-786	2	
<b>OTHER PARTS GROUP</b>							
W301		00D 941 0049 704	3P 2.5 CONNECTOR WIRE (L=400)		404-390-2166	1	*
JK301		00D 958 0018 102	3P PHONE JACK		420-DCM270X-062	1	
L301-303		00D 958 0016 900	BEAD CORE(86-019-A)		415-HV3500K-090	3	
CHASSIS		-	GROUND WIRE (L=60)		406-390-827	1	*
		-	1P GROUND WIRE (L=80)		406-HV3500K-408	1	
		00D 941 0050 803	EMI CORE		415-390-277	1	*

## PHOTO TRANSISTOR P.W.B. UNIT ASS'Y

Ref. No.	nsp	Part No.	Part Name	Remarks		Q'ty	New
Q01		00D 958 0018 209	PHOTO TRANSISTOR(LTR-301)		416-DCM270X-120	1	

## INFERARED EMITTING P.W.B. UNIT ASS'Y

Ref. No.	nsp	Part No.	Part Name	Remarks		Q'ty	New
D01		00D 958 0018 403	INFERARED EMITTING DIODE(LTE-4206C)		410-DCM270X-132	1	
R01		-	CARBON FILM RESISTOR (390K OHM,1/6W)		412-3113-076	1	
		00D 958 0021 005	ROUND PLASTIC SPACER(302A)		605-DCM270-055	1	

## AC JACK P.W.B. UNIT ASS'Y

Ref. No.	nsp	Part No.	Part Name	Remarks		Q'ty	New
		00D 941 0049 801	AC SOCKET	for 390BKE3/290BKE3/ 27BKE3	404-DJ2-021	1	*
		00D 941 0050 405	AC SOCKET	for 500AEBKE2/500AESPE2	404-HDJ2200E-969	1	*
		-	FUSE CLIPS		420-KT350A-004	2	
		00D 958 0016 900	BEAD CORE(86-019-A)		415-HV3500K-090	2	
⚠ FUSE01		00D 941 0049 908	FUSE(1A/250V)	for 390BKE3/290BKE3/ 27BKE3	422-CDN12F-028	1	
⚠ FUSE01		00D 941 0050 007	FUSE(T1AL/250V)	for DCM500AEBKE2/ DCM500AESPE2	422-HDJ7100-022	1	
		-	FUSE COVER		504-DJ2500J-046	1	

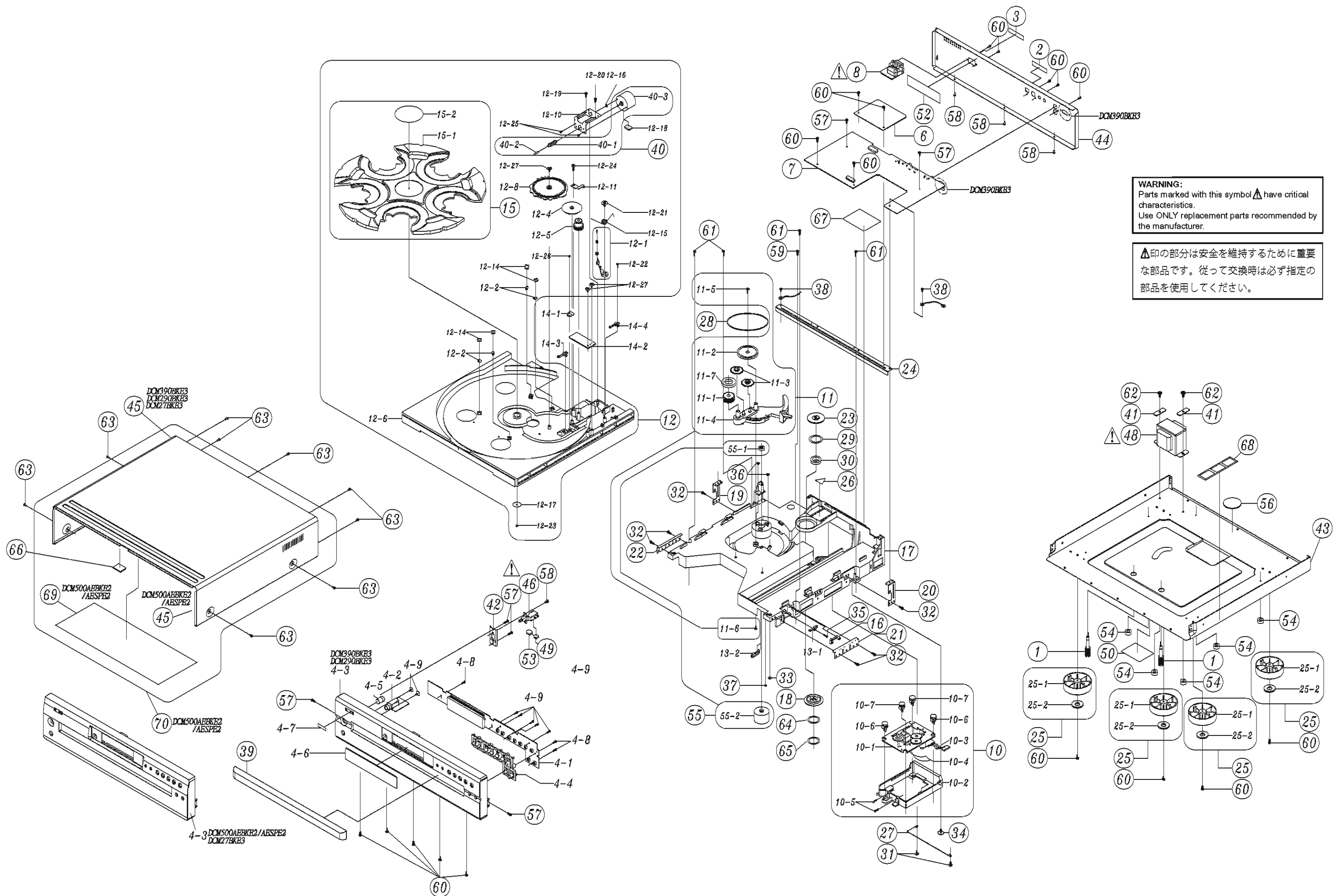

**WARNING:**  
Parts marked with this symbol  have critical characteristics.  
Use ONLY replacement parts recommended by the manufacturer.

印の部分は安全を維持するために重要な部品です。従って交換時は必ず指定の部品を使用してください。



## PARTS LIST OF EXPLODED VIEW

\* 本表に記載されている部品は、補修用部品のため製品に使用している部品とは一部、形状、寸法などが異なる場合があります。

\* The parts listed below are for maintenance only, might differ from the parts used in the unit in appearances or dimensions.

\* "nsp" 印の部品は常時在庫していませんので供給に長時間を要することがあります。場合によっては、供給をお断りする場合があります。

\* Part indicated with the mark "nsp" are not always in stock and possibly to take a long period of time for supplying, or in some case supplying of part may be refused.

Note: The symbols in the column "Remarks" indicate the following destinations.

BKE3 : U.S.A. & Canada model (Black)

BKE2 : Europe model (Black)

SPE2 : Europe model (Premium Silver)

Ref. No.	nsp	Part No.	Part Name	Remarks	Q'ty	New
1	nsp	00D 958 0009 807	SCREW ASS'Y		701-AVD3500K-1668	2
2		-	DATE LABEL	for 390BKE3/290BKE3/ 27BKE3	701-DCM270BK-1930	1
3		-	SERIAL NO. LABEL		701-DCM270BK-1931	1
4-1		00D 941 0041 207	CONTROL PCB ASS'Y	for 390BKE3/290BKE3	704-390-6142	1 *
4-1		00D 941 0051 906	CONTROL PCB ASS'Y	for 27BKE3	704-27-6327	1 *
4-1		00D 941 0041 304	CONTROL PCB ASS'Y	for 500AEBKE2/500AESPE2	704-500AE-6326	1 *
4-2		00D 941 0041 401	PHONE PCB ASS'Y		704-390-6145	1 *
4-3		00D 941 0041 508	FRONT PANEL	for 390BKE3	100-390-2371	1 *
4-3		00D 941 0041 605	FRONT PANEL	for 290BKE3	100-290-2371	1 *
4-3		00D 941 0041 702	FRONT PANEL	for 27BKE3	100-27-2372	1 *
4-3		00D 941 0041 809	FRONT PANEL	for 500AEBKE2	100-500-2372	1 *
4-3		00D 941 0041 906	FRONT PANEL	for 500AESPE2	100-500SP-2372	1 *
4-4		00D 941 0042 002	KNOB	for 390BKE3/290BKE3	100-390-2375	1 *
4-4		00D 941 0042 109	KNOB	for 27BKE3/500AEBKE2	100-27-2376	1 *
4-4		00D 941 0042 206	KNOB	for 500AESPE2	100-500-2376	1 *
4-5		00D 941 0042 303	POWER KNOB	for 390BKE3/290BKE3/ 27BKE3/500AEBKE2	100-390-2393	1 *
4-5		00D 941 0042 400	POWER KNOB	for 500AESPE2	100-500-2393	1 *
4-6		00D 941 0042 507	DECORATION		501-390-1884	1 *
4-7		00D 941 0042 604	BADGE	for 390BKE3/290BKE3/ 27BKE3/500AEBKE2	501-390-1888	1 *
4-7		00D 941 0042 701	BADGE	for 500AESPE2	501-500-1888	1 *
4-8		-	SCREW (SAE1018,BTP,Φ3X8)		602-2002-077	2
4-9		-	SCREW (SAE1018,PTP,Φ2.6X8)		602-SL24F-099	8
4-10		-	SCREW (TTP 2.6X7 CAP 10Z)		602-DV300-5023	2
6		00D 941 0050 502	BUFFER PCB ASS'Y	for 390BKE3/290BKE3/27BKE3	704-390-6143	1 *
6		00D 941 0053 101	BUFFER PCB ASS'Y	for 500AEBKE2/500AESPE2	704-C200-6659	1 *
7		00D 941 0050 104	SERVO PCB ASS'Y	for 390BKE3	704-390-6146	1 *
7		00D 941 0050 201	SERVO PCB ASS'Y	for 290BKE3/27BKE3/ 500AEBKE2/500AESPE2	704-290-6153	1 *
8		00D 941 0050 609	AC JACK ASS'Y	for 390BKE3/290BKE3/ 27BKE3	704-390-6147	1 *
8		00D 941 0050 706	AC JACK ASS'Y	for 500AEBKE2/500AESPE2	704-290-6154	1 *
10		00D 941 0042 808	CD HEAD TRACKING ASS'Y		701-KMD550-1588	1
10-1		-	MECHA ASS'Y (KSM-213CCM)		704-HV3423K-1441	1
10-2		-	CD DECK HOLDER		100-KMD550-1220B	1
10-3		-	6P CONNECTOR WIRE		404-KMD5000-663	1
10-4		-	RIBBON WIRE (16PIN)		406-KMD5000-413	1
10-5		-	SCREW (PTP M3X14)		602-KMD550-250	2
10-6		-	CUSHION RUBBER (RED)		604-KMD550-117	2
10-7		-	CUSHION RUBBER (WHITE)		604-KMD550-118	2
11		00D 941 0042 905	GEAR SLIDE PLATE ASSY		701-KMD550-1603	1
11-1		-	B.GEAR		100-KMD280-727	1
11-2		-	BELT GEAR		100-KMD280-732B	1
11-3		-	S.GEAR		100-KMD280-734	2
11-4		-	GEAR SET		100-KMD550-860D2	1
11-5		-	SCREW (M3X8 PTP)		602-KMD510-169	1
11-6		-	SCREW (PTP 4X8mm L)		602-KMD550-261	1
11-7		-	WASHER (Φ13X8.1Xt0.4)		606-CMP1000-187	1

Ref. No.	nsp	Part No.	Part Name	Remarks		Q'ty	New
12		00D 941 0050 308	TRAY ASS'Y		701-DCM280-3311	1	
12-1		-	CORRECTING LEVER ASS'Y		701-KMD550-1593	1	
12-2		-	WHEEL		100-KMD280-729	4	
12-4		-	MIDDLE GEAR		100-KMD280-733	1	
12-5		-	TRANSFER GEAR		100-KMD280-736A	1	
12-6		-	BASE		100-KMD550-1214C	1	
12-8		-	DRIVE GEAR		100-KMD550-1216	1	
12-10		-	MOTER FIXED PLATE		300-KMD550-262	1	
12-11		-	FORWARD GEAR FIXED IRON		300-KMD280-305	1	
12-14		-	FIXED SHEET (PVC)		501-KMD550-1146	4	
12-15		-	COMMENTING SPRING		603-KMD550-199	1	
12-16		-	WASHER		606-H900-052	1	
12-17		-	FIXED CENTER WASHER		606-C426-066	1	
12-18		-	MUTE SHEET		612-KMD510-032	1	
12-19		-	SCREW		602-M100-032	1	
12-20		-	SCREW (M3X8mm BTP)		602-2002-077	1	
12-21		-	SCREW (M3X9mm PTP)		602-SL24F-097	1	
12-22		-	SCREW (2.6X8PTP)		602-SL24F-099	1	
12-23		-	SCREW (TTP 3X10 ZK PTP)		602-MK7-131	1	
12-24		-	SCREW (2.6X5.5mm)		602-KM300-144	1	
12-25		-	SCREW (M2.6X3mm)		602-KM500-155	2	
12-26		-	SCREW (TTP M2.6X6 PTP)		602-KMD510-158	1	
12-27		-	SCREW (TTP 2.6X7 CAP 10Z)		602-DV300-5023	3	
15		00D 941 0043 001	DISK ASS'Y		701-KMD550B-1900	1	*
15-1		-	DISK		100-KMD550-1215A	1	
15-2		-	FIXED SHEET		501-KMD550-1099	1	
40		00D 941 0043 409	MOTOR SPIRAL GEAR ASS'Y		704-390-6331	1	*
40-1		-	SPIRAL GEAR		100-KMD280-731A	1	
40-2		-	SHAFT		200-KMD280-174	1	
40-3		-	MOTOR (MEN-7E2T5,DC12V)		401-MK7-043A	1	
13-1		00D 958 0003 405	LEAF SW (LSA-1119H,2PIN)		403-DM11A-020	1	
13-2		00D 958 0002 105	LEAF SW (LSA-2127E,3PIN)		403-KMD280-048	1	
14-1		00D 958 0003 803	PHOTO TRANSISTOR PCB ASS'Y		704-DCM270X-1797	1	
14-2		00D 958 0002 008	INFRARED EMITTING PCB ASS'Y		704-DCM270X-1798	1	
14-3		00D 958 0003 405	LEAF SW (LSA-1119H,2PIN)		403-DM11A-020	1	
14-4		00D 958 0005 704	LEAF SW (LSA-1119F,2PIN)		403-KMD550-087	1	
16		-	SWITCH CONTROL		100-KMD280-730	1	
17		-	BOTTOM BASE		100-KMD550-1213A	1	
18		-	DISK HOLDER		100-KMD550-1219	1	
19		-	L.FIXED PLATE		300-KMDV280C-263A	1	
20		-	R.FIXED PLATE		300-KMDV280C-264A	1	
21		-	STAY R		300-KMD280-265RA	1	
22		-	STAY L		300-KMD550-265L	1	
23		-	SWIVEL PLATE		300-KMD550-466	1	
24		-	MAIN PCB BRACKET		300-390-486A	1	*
25	nsp	00D 941 0043 108	FOOT ASS'Y		701-390-3728	4	*
25-1		-	FOOT (ABS,KURZ BM82361)		100-390-2374	4	*
25-2		-	FOOT		612-DCM370-067	4	
26		-	LASER BEAM LABEL		501-1033-428	1	
27		-	STEEL WIRE		603-KMD280-200	1	
28		00D 958 0001 708	MOTOR BELT		604-KMD280-094	1	
29		-	WASHER (HIMERON BLACK 18)		612-KT300-007	1	
30		-	MAGNET (Φ30X18X5t,650Gm)		613-MK7-002A	1	
31		-	SCREW (TTP CAP M3X8mm)		602-B600-056	2	
32		-	SCREW (SAE1018,BTP,Φ3X8)		602-2002-077	6	
33		-	SCREW (M3X7 PTP)		602-SL24F-096	1	

	Ref. No.	nsp	Part No.	Part Name	Remarks		Q'ty	New
	34		-	SCREW (M3X9mm PTP)		602-SL24F-097	1	
	35		-	SCREW (SAE1018,PTP,Φ2.6X8)		602-SL24F-099	1	
	36		-	SCREW (M2.6X4 P0.45)		602-MK7-134	2	
	37		-	SCREW (PTP M3X14)		602-KMD550-250	1	
	38		-	SCREW (W BTP 2.6X6 MC)		602-KMD550-255	2	
	39		00D 941 0043 205	CD DOOR	for 390BKE3/290BKE3/ 27BKE3/500AEBKE2	100-390-2373	1	*
	39		00D 941 0043 302	CD DOOR	for 500AESPE2	100-500-2373	1	*
	41		-	BRACKET TRANSFORMER		300-DV300B-443	2	
	42		-	POWER SWITCH BRACKET		300-HDJ7000-478	1	
	43		-	BUTTOM BASE		300-CDC2050-502B	1	*
	44	nsp	00D 941 0043 506	BACK BOARD	for 390BKE3	300-390-573A	1	*
	44	nsp	00D 941 0043 603	BACK BOARD	for 290BKE3	300-290-573A	1	*
	44	nsp	00D 941 0043 700	BACK BOARD	for 27BKE3	300-27-573A	1	*
	44	nsp	00D 941 0043 807	BACK BOARD	for 500AEBKE2/500SPE2	300-500-573A	1	*
	70		00D 941 0051 307	TOP COVER WITH METAL PLATE ASS'Y	for 500AEBKE2	703-500-1047	1	*
	70		00D 941 0051 404	TOP COVER WITH METAL PLATE ASS'Y	for 500AESPE2	703-500S-1047	1	*
	69		-	METAL PLATE	for 500AEBKE2/500SPE2	300-500-1421	1	*
	45		-	TOP COVER	for 500AEBKE2	300-390-574	1	*
	45		-	TOP COVER	for 500AESPE2	300-500-574	1	*
	45		00D 941 0043 904	TOP COVER	for 390BKE3/290BKE3/ 27BKE3	300-390-574	1	*
	66		-	HIMILON (0.5t, 19X6.5mm)	for 500AEBKE2/500SPE2	612-390-248	1	*
⚠	46		00D 958 0008 303	POWER SW (SDDL1017U-HF,2PIN)		403-A100-005	1	
⚠	48		00D 941 0044 301	TRANSFORMER (AC120V)	for 390BKE3/290BKE3/ 27BKE3	411-385-527	1	*
⚠	48		00D 941 0044 408	TRANSFORMER (AC230V)	for 500AEBKE2/500AESPE2	411-385-528	1	*
	49		-	AC CAPACITOR (0.01uF/250V,M,BULK,Y5V)		413-S250-747	1	
	50		-	TRANSFER SCREWS LABEL		501-HT8023K-949	1	
	52		-	FUSE LABEL (80X20mm,y=0.1mm)	for 390BKE3/290BKE3/ 27BKE3	501-390BKE3-1269	1	*
	53		-	CNR COVER (HU-13A-PRW)		504-SPANDMK2-160	1	
	54		-	PROTECTION MAT		612-HMD5000-065	5	
	55		00D 941 0044 505	MOTOR PULLEY ASS'Y		704-390-6332	1	
	55-1		-	MOTOR PULLEY		100-KMD280-728	1	
	55-2		-	MOTOR (MEN-7E2T5,DC12V)		401-MK7-043A	1	
	56		-	CUSHION (EVA,Φ31.3,t=1)		612-DCM280-215	1	
	57		-	SCREW (SAE1018,BTP,Φ3X8)		602-2002-077	4	
	58		-	SCREW (3X5mm,BLACK)		602-KE200-145	4	
	59		-	SCREW (TTB M3X10mm)		602-HP1010K-174	1	
	60		-	SCREW (3X8mm)		602-HP1010K-175	18	
	61		-	SCREW (TTB M3X12mm)		602-DV300B-219	4	
	62		-	SCREW (4X8mm TTB BLACK)		602-DCM270-281	2	
	63		-	SCREW (3X8)	for 390BKE3/290BKE3/ 27BKE3/500AEBKE2	602-DCM280-429	9	
	63		-	SCREW (3X8)	for 500AESPE2	602--HT8011-192	9	
	64		-	PC WASHER		612-DCM390-247	1	*
	65		-	PC WASHER		501-DCM280-1628	1	
	67		-	LASER CAUTION LABEL (0.08t, 52X26mm)	for 390BKE3/290BKE3/ 27BKE3	501-390BKE3-1924	1	
	67		-	LASER CAUTION LABEL (0.08t, 52X26mm)	for 500AEBKE2/500SPE2	501-500SPE2-1924	1	
	68		-	LASE LABEL (0.08t, 52X26mm)	for 500AEBKE2/500SPE2	501-500SPE2-1925	1	*

## EXPLODED VIEW OF CD MECHANISM UNIT (CD TRAV/UNIT KSM-213CCM)

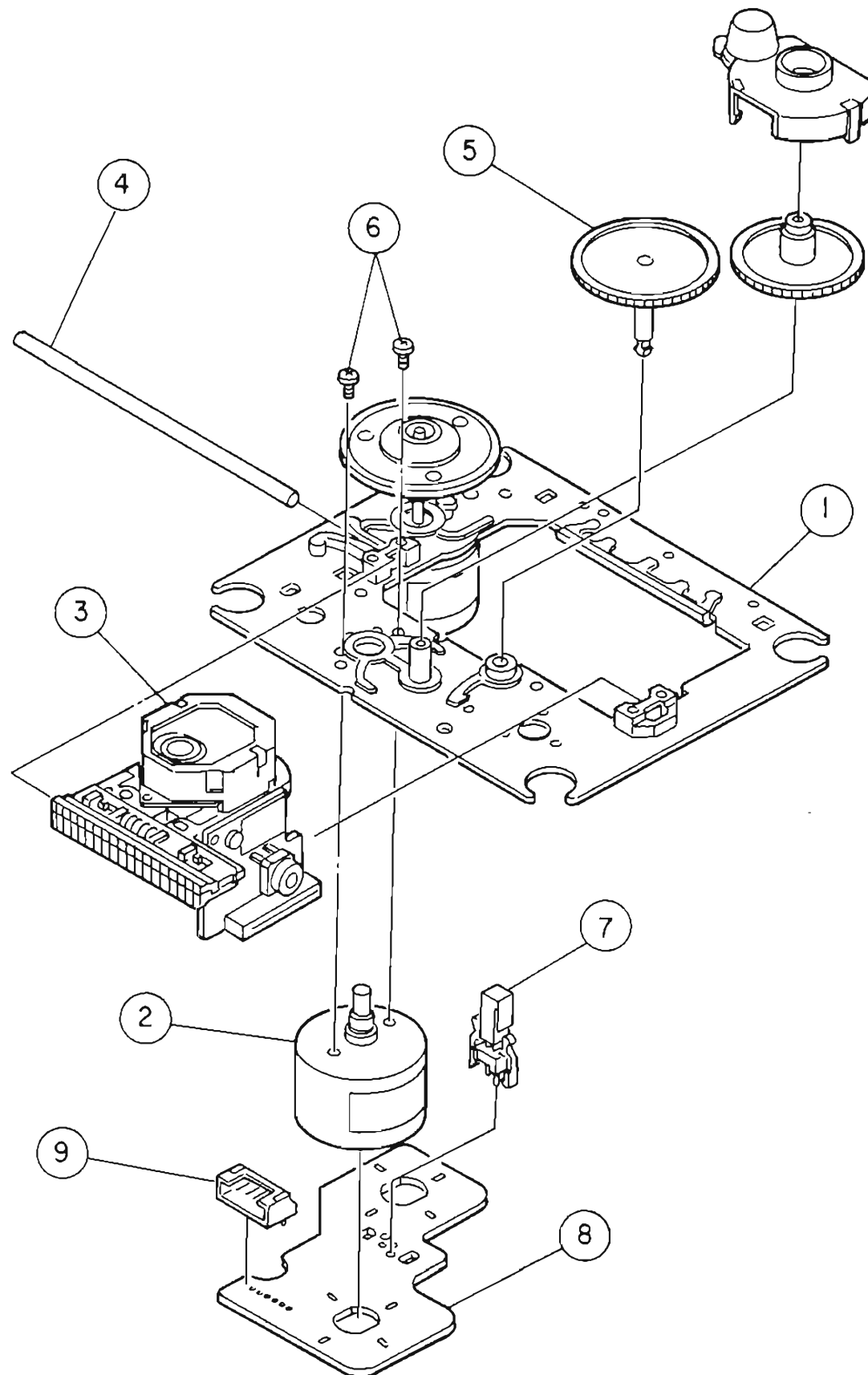

## PARTS LIST OF CD MECHANISM UNIT

\*本表に記載されている部品は、補修用部品のため製品に使用している部品とは一部、形状、寸法などが異なる場合があります。

\* The parts listed below are for maintenance only, might differ from the parts used in the unit in appearances or dimensions.

\* "nsp" 印の部品は常時在庫していませんので供給に長時間を要することがあります。場合によっては、供給をお断りする場合があります。

\* Part indicated with the mark "nsp" are not always in stock and possibly to take a long period of time for supplying, or in some case supplying of part may be refused.

Ref.No.	nsp	Part No.	Part Name	Remarks	Q'ty	New
1	nsp	00D SX2 6258 771	MOTOR CHASSIS ASS'Y	KSS-213C	1	
2	nsp	00D SX2 6257 691	MOTOR GEAR ASS'Y		1	
3	nsp	00D S88 4841 509	OPTICAL PU		1	
4	nsp	00D S26 2690 801	SLIDE SHAFT		1	
5	nsp	00D S26 2690 701	GEAR(A)(S)		1	
6	nsp	00D S76 2125 510	SCREW 2x3		2	
7	nsp	00D S15 7208 511	LEAF SW		1	
8	nsp	00D S16 3967 812	MOTOR (6P) (S) PCB		1	
9	nsp	00D S15 6472 211	6P CONNECTOR (PIN)		1	

POINTS OF GREASING  $\Delta$

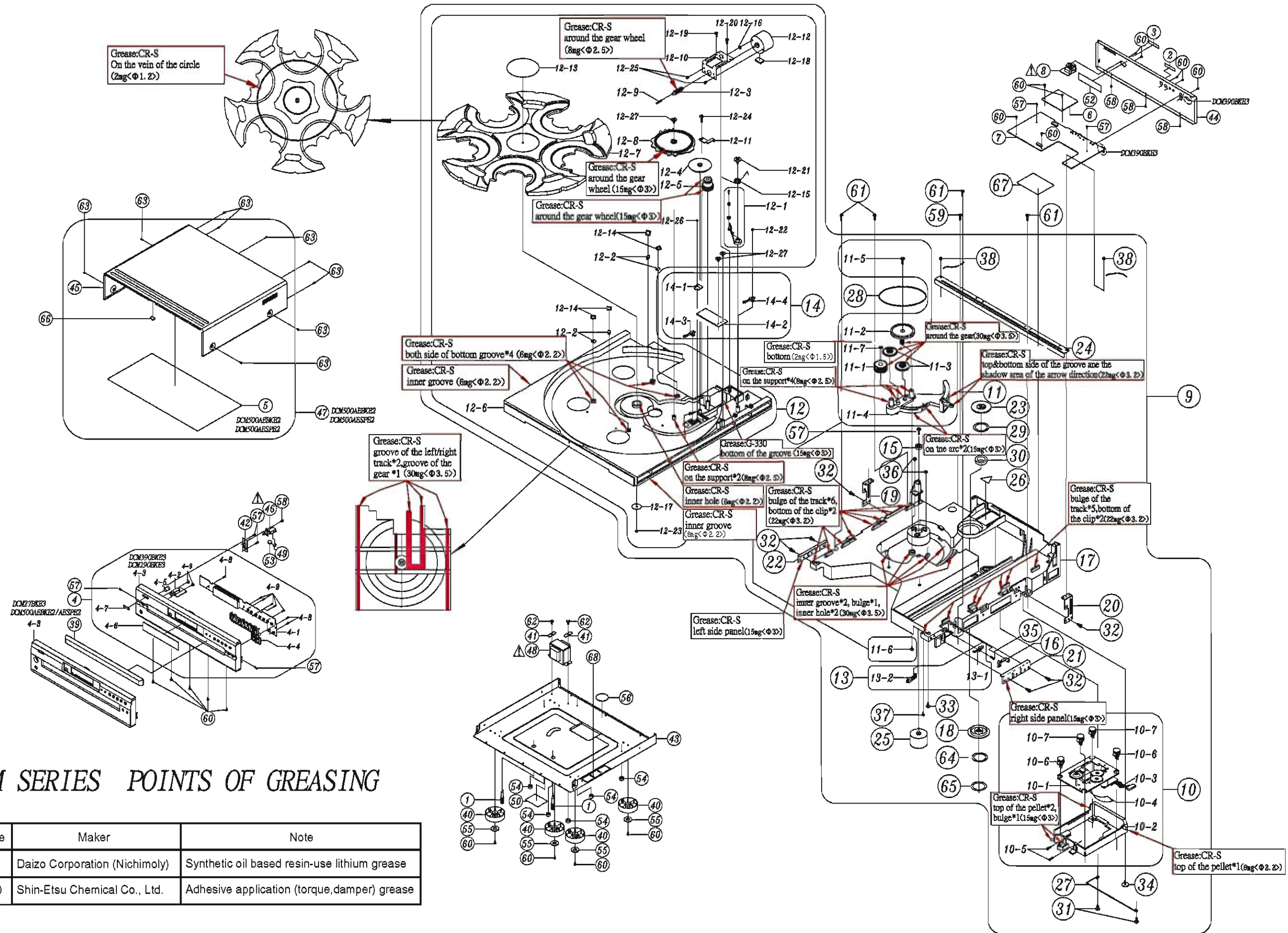

DCM SERIES POINTS OF GREASING

Grease	Maker	Note
CR-S	Daizo Corporation (Nichimoly)	Synthetic oil based resin-use lithium grease
G-330	Shin-Etsu Chemical Co., Ltd.	Adhesive application (torque,damper) grease

## PACKING VIEW

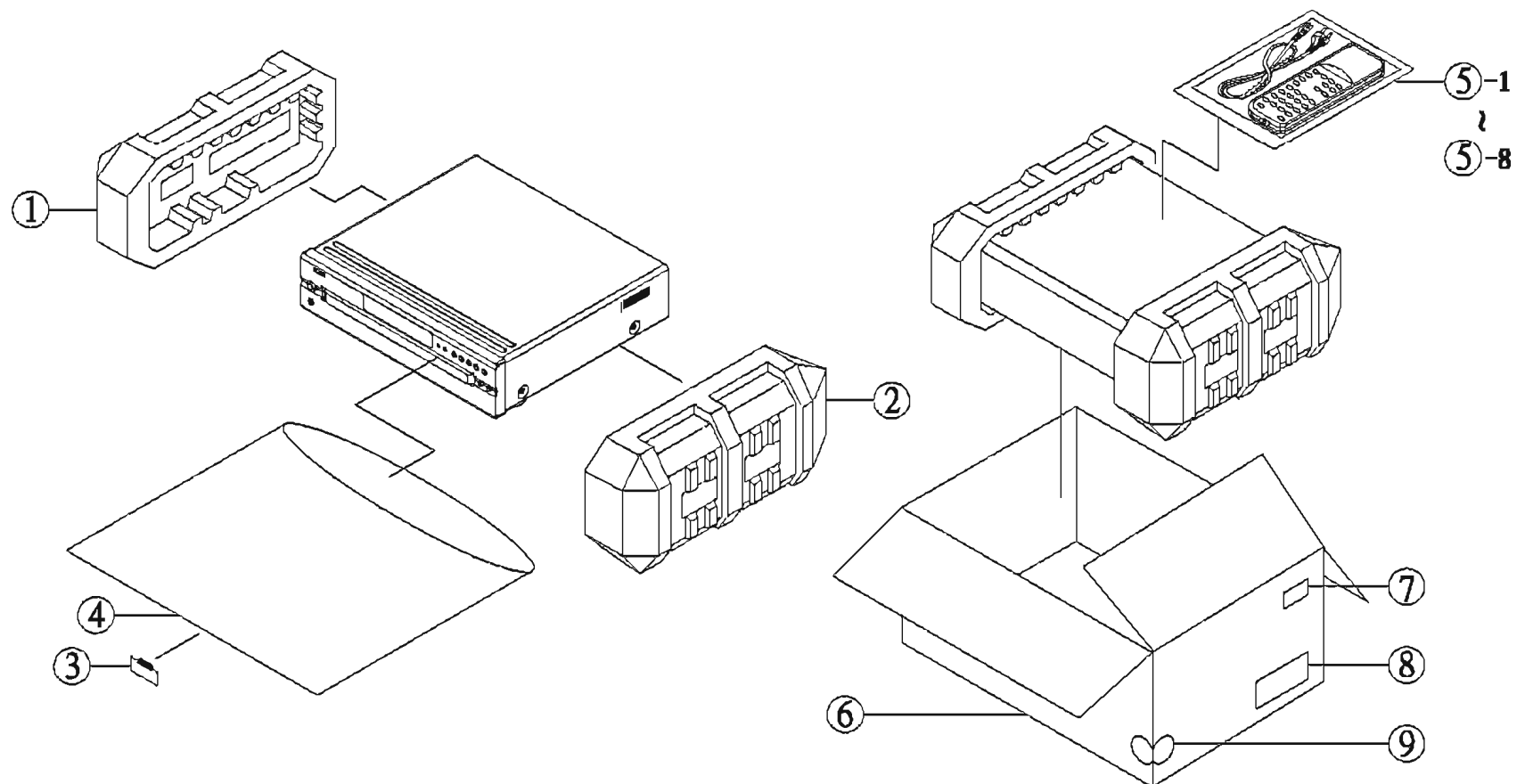

## PARTS LIST OF PACKING &amp; ACCESSORIES

\* 本表に記載されている部品は、補修用部品のため製品に使用している部品とは一部、形状、寸法などが異なる場合があります。

\* The parts listed below are for maintenance only, might differ from the parts used in the unit in appearances or dimensions.

\* "nsp" 印の部品は常時在庫していませんので供給に長時間を要することがあります。場合によっては、供給をお断りする場合があります。

\* Part indicated with the mark "nsp" are not always in stock and possibly to take a long period of time for supplying, or in some case supplying of part may be refused.

**Note:** The symbols in the column "Remarks" indicate the following destinations.

BKE3 : U.S.A. & Canada model (Black)

BKE2 : Europe model (Black)

SPE2 : Europe model (Premium Silver)

	Ref. No.	nsp	Part No.	Part Name	Remarks		Q'ty	New
	1	nsp	00D 941 0044 602	Polyfoam L		506-500-449L	1	*
	2	nsp	00D 941 0044 709	Polyfoam R		506-500-449R	1	*
	3		-	TRANSPORTATION SCREW LABEL		501-DCM270-1260	1	
	4	nsp	00D 958 0023 304	SOFT BAG		509-390-186	1	
	5-1		00D 399 1053 008	REMOTE CONTROL	for 390BKE3/290BKE3/27BKE3/ 500AEBKE2	704-385BK-6065	1	*
	5-1		00D 399 1053 011	REMOTE CONTROL	for 500AESPE2	704-500SP-6102	1	*
	5-2		00D 941 0044 806	INTSRUCTION BOOK	for 390BKE3/290BKE3/27BKE3	502-290BKE3-2009	1	*
	5-2		00D 941 0044 903	INTSRUCTION BOOK	for 500AEBKE2/500AESPE2	502-500AE-2010	1	*
	5-3		00D 958 0011 400	2P RCA PATH CORD		408-DV300-5001	1	
	5-4		-	DRY BATTERY		426-DV300-5001	2	
	5-5		00D 515 0944 406	WARRANTY (HOME)	for 390BKE3/290BKE3/27BKE3	502-380BKE3-1329D	1	
	5-6		00D 515 0921 607	S.S.LIST (EX)		502-DCM280-1347D	1	
⚠	5-7		00D 941 0044 107	AC CORD (L=1900+/-50mm,UL)	for 390BKE3/290BKE3/27BKE3	409-DJ2-069A	1	*
⚠	5-7		00D 941 0044 204	AC CORD (L=1900mm,VDE,TYPE)	for 500AEBKE2/500AESPE2	409-DJ2-070A	1	*
	5-8		-	POLYBAG		509-DJ2500H-046	1	
	6	nsp	00D 941 0045 009	GIFT BOX	for 390BKE3	507-390-2658	1	*
	6	nsp	00D 941 0045 106	GIFT BOX	for 290BKE3	507-290BKE3-2658	1	*
	6	nsp	00D 941 0045 203	GIFT BOX	for 27BKE3	507-27BKE3-2658	1	*
	6	nsp	00D 941 0045 300	GIFT BOX	for 500AEBKE2/500AESPE2	507-500BKE2-2658	1	*
	7		-	BAR CORD	for 390BKE3	501-390BKE3-1248	1	*
	7		-	BAR CORD	for 290BKE3	501-290BKE3-1248	1	*
	7		-	BAR CORD	for 27BKE3	501-27BKE3-1248	1	*
	7		-	BAR CORD	for 500AEBKE2	501-500AEB2-1248	1	*
	7		-	BAR CORD	for 500AESPE2	501-500AES2-1248	1	*
	8		-	BAR CORD	for 390BKE3	701-390BKE3-3513	2	*
	8		-	BAR CORD	for 290BKE3	701-290BKE3-3513	2	*
	8		-	BAR CORD	for 27BKE3	701-27BKE3-3513	2	*
	8		-	BAR CORD	for 500AEBKE2	701-500AEB2-3513	2	*
	8		-	BAR CORD	for 500AESPE2	701-500AES2-3513	2	*
	9		-	Color label	for 500AESPE2	501-300FSPE2-1906	2	

## NOTE FOR SCHEMATIC DIAGRAM

### WARNING:

Parts marked with this symbol  $\triangle$  have critical characteristics. Use ONLY replacement parts recommended by the manufacturer.

### CAUTION:

Before returning the unit to the customer, make sure you make either (1) a leakage current check or (2) a line to chassis resistance check. If the leakage current exceeds 0.5 milliamps, or if the resistance from chassis to either side of the power cord is less than 460 kohms, the unit is defective.

### WARNING:

DO NOT return the unit to the customer until the problem is located and corrected.

### NOTICE:

ALL RESISTANCE VALUES IN OHM. k=1,000 OHM  
M=1,000,000 OHM  
ALL CAPACITANCE VALUES IN MICRO FARAD.  
P=MICRO-MICRO FARAD  
EACH VOLTAGE AND CURRENT ARE MEASURED AT  
NO SIGNAL INPUT CONDITION.  
CIRCUIT AND PARTS ARE SUBJECT TO CHANGE  
WITHOUT PRIOR NOTICE.

## 配線図について

$\triangle$ 印の部品は安全を維持するために重要な部品です。従って交換時は必ず指定の部品を使用してください。

### 注)

- (1) 指定なき抵抗値は  $\Omega$ 、k は  $k\Omega$ 、M は  $M\Omega$  を示す。
- (2) 指定なきコンデンサーの値は  $\mu F$ 、p は  $pF$  を示す。
- (3) 各部の電圧は無信号の値を示す。
- (4) この配線図は基本配線図です。改良等のため変更することがありますのでご了承ください。

SCHEMATIC DIAGRAMS (1/3)

1 2 3 4 5 6 7 8

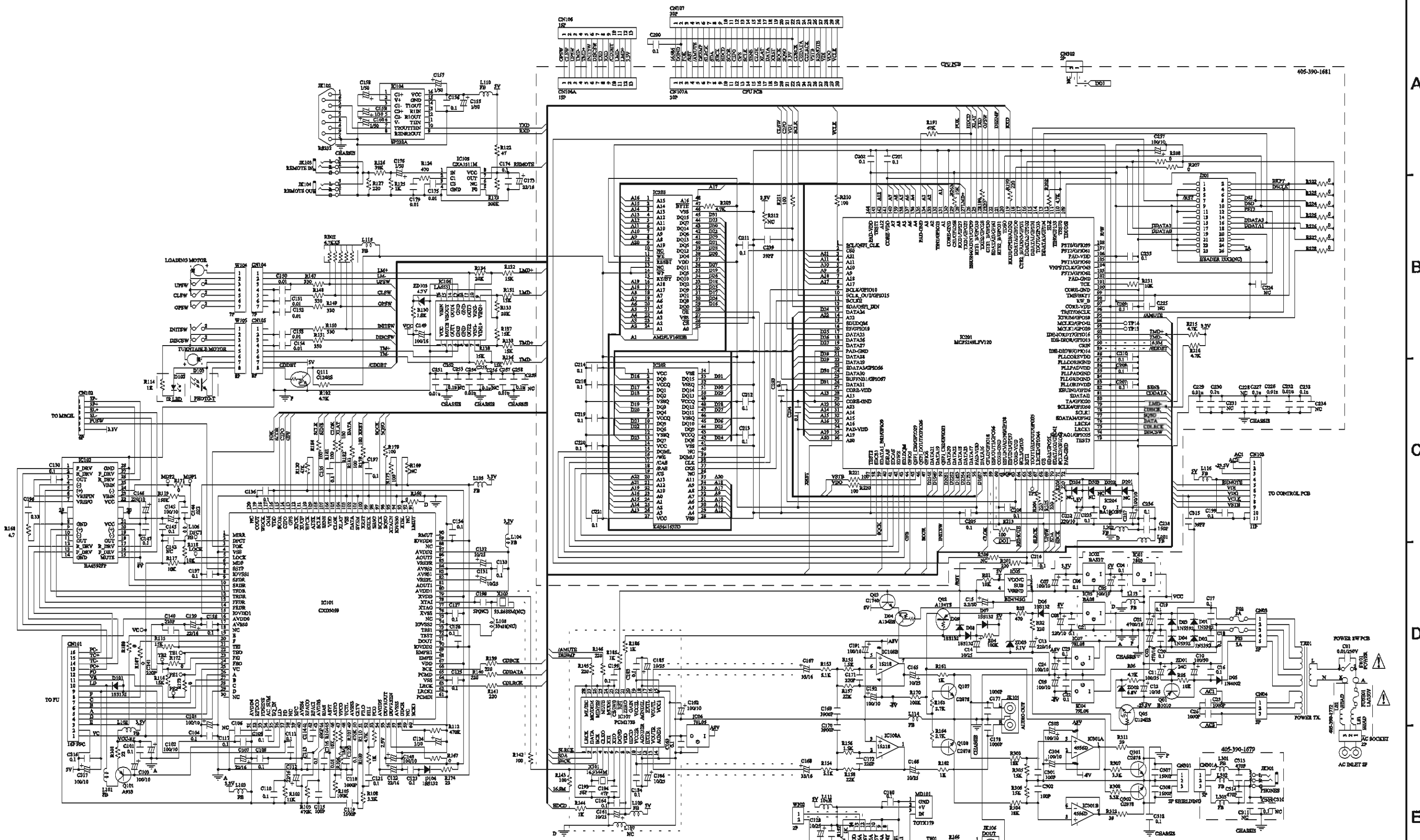

SCHEMATIC DIAGRAMS (1/3)  
SERVO UNIT PHONE UNIT  
BUFFER UNIT AC SOCKET UNIT  
(for DCM-390 model)



SCHEMATIC DIAGRAMS (2/3)

1 2 3 4 5 6 7 8

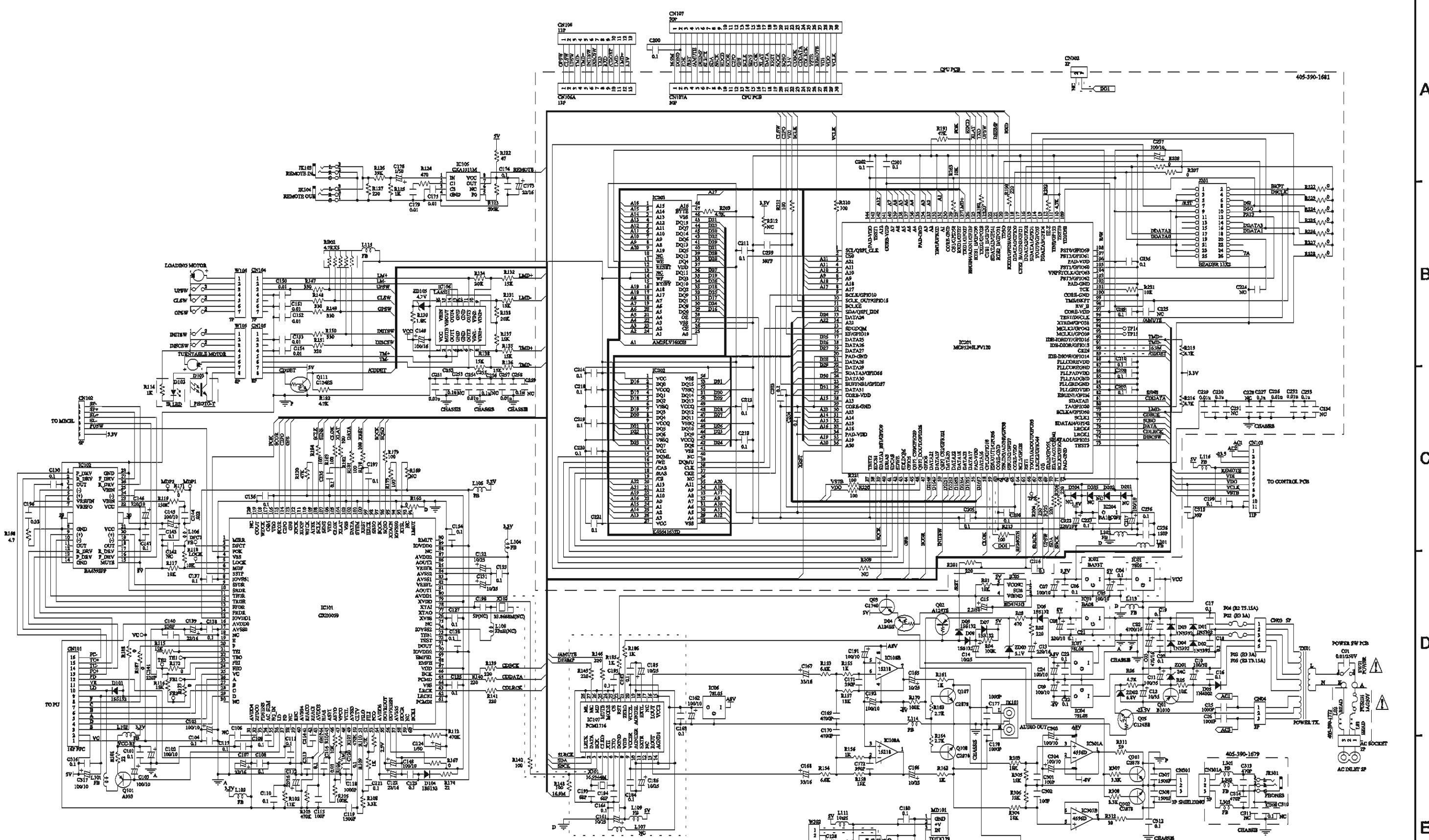

SCHEMATIC DIAGRAMS (2/3)  
SERVO UNIT PHONE UNIT  
BUFFER UNIT AC SOCKET UNIT  
(for DCM-290/27/500AE model)

SCHEMATIC DIAGRAMS (3/3)

1 2 3 4 5 6 7 8

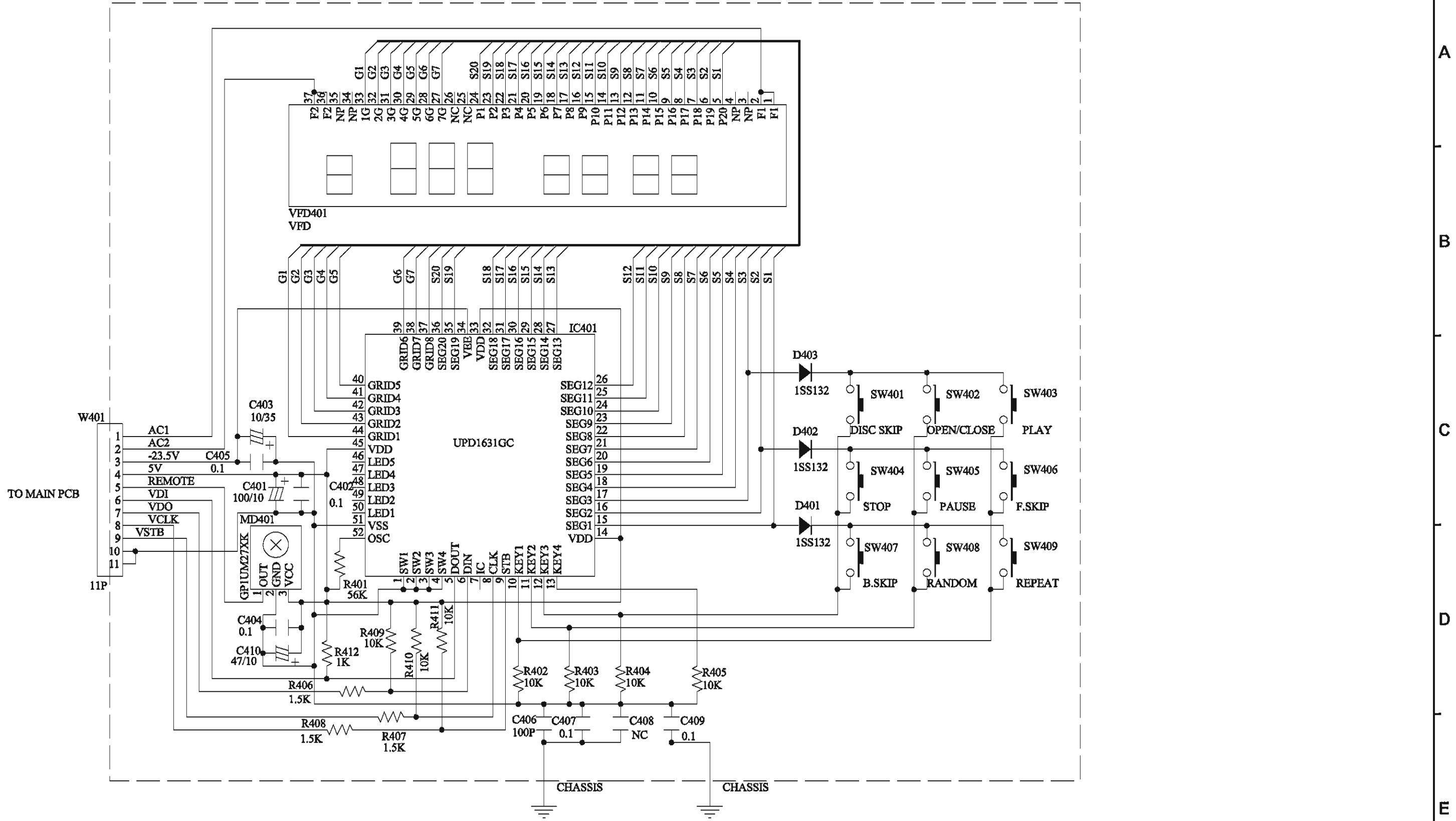

SCHEMATIC DIAGRAMS (3/3)  
CONTROL UNIT

## DOCUMENTS FOR WEEE

## Details of Recycle parts for Main Unit

\* You have to remove the parts that marked "WEEE Mark ◆" when the recycling processing. (Europe model only)

Ref. No.	nsp	Part Name	Material	Q'ty
1	◆	SCREW ASS'Y	COMPLEX	2
2		DATE LABEL	POLYESTER	1
3		SERIAL NO. LABEL	PAPER	1
4-1	◆	CONTROL P.W.B. ASS'Y	COMPLEX	1
4-2	◆	PHONE P.W.B. ASS'Y	COMPLEX	1
4-3		FRONT PANEL	ABS	1
4-4		KNOB	ABS	1
4-5	◆	POWER KNOB	COMPLEX	1
4-6		DECORATION	PC	1
4-7		BADGE	ALUMINUM	1
4-8		SCREW (SAE1018,BTP,Φ3X8)	SWCH	2
4-9		SCREW (SAE1018,PTP,Φ2.6X8)	SWCH	8
4-10		SCREW (TTP 2.6X7 CAP 10Z)	SWCH	2
6	◆	BUFFER P.W.B. ASS'Y	COMPLEX	1
7	◆	SERVO P.W.B. ASS'Y	COMPLEX	1
8	◆	AC JACK ASS'Y	COMPLEX	1
10-1	◆	MECHA ASS'Y (KSM-213CCM)	COMPLEX	1
10-2	◆	CD DECK HOLDER	COMPLEX	1
10-3	◆	6P CONNECTOR WIRE	COMPLEX	1
10-4	◆	RIBBON WIRE (16PIN)	COMPLEX	1
10-5		SCREW (PTP M3X14)	SWCH	2
10-6		CUSHION RUBBER (RED)	SILICON RUBBER	2
10-7		CUSHION RUBBER (WHITE)	SILICON RUBBER	2
11-1		B.GEAR	POM	1
11-2		BELT GEAR	PA	1
11-3		S.GEAR	PA	2
11-4		GEAR SET	ABS	1
11-5		SCREW (M3X8 PTP)	SWCH	1
11-6		SCREW (PTP 4X8mm L)	SWCH	1
11-7		WASHER(Φ13X8.1Xt0.4)	ABS	1
12-1	◆	CORRECTING LEVER ASS'Y	COMPLEX	1
12-2		WHEEL	POM	4
12-4		MIDDLE GEAR	POM	1
12-5		TRANSFER GEAR	PA	1
12-6		BASE	ABS	1
12-8		DRIVE GEAR	POM	1
12-10		MOTER FIXED PLATE	SPCC	1
12-11		FORWARD GEAR FIXED IRON	SPCC	1
12-14		FIXED SHEET (PVC)	PVC	4
12-15		COMMENTING SPRING	SUS	1
12-16		WASHER	SPCC	1
12-17		FIXED CENTER WASHER	SPCC	1
12-18		MUTE SHEET	CR FOAM	1
12-19		SCREW	SWCH	1
12-20		SCREW (M3X8mm BTP)	SWCH	1
12-21		SCREW (M3X9mm PTP)	SWCH	1
12-22		SCREW (2.6X8PTP)	SWCH	1
12-23		SCREW (TTP 3X10 ZK PTP)	SWCH	1
12-24		SCREW (2.6X5.5mm)	SWCH	1
12-25		SCREW (M2.6X3mm)	SWCH	2
12-26		SCREW (TTP M2.6X6 PTP)	SWCH	1
12-27		SCREW (TTP 2.6X7 CAP 10Z)	SWCH	3
13-1	◆	LEAF SW (LSA-1119H,2PIN)	COMPLEX	1
13-2	◆	LEAF SW (LSA-2127E,3PIN)	COMPLEX	1
14-1	◆	PHOTO TRANSISTOR P.W.B. ASS'Y	COMPLEX	1
14-2	◆	INFRARED EMITTING P.W.B. ASS'Y	COMPLEX	1
14-3	◆	LEAF SW (LSA-1119H,2PIN)	COMPLEX	1

Ref. No.	nsp	Part Name	Material	Q'ty
14-4	◆	LEAF SW (LSA-1119F,2PIN)	COMPLEX	1
15-1		DISK	ABS	1
15-2		FIXED SHEET	PVC	1
16		SWITCH CONTROL	POM	1
17		BOTTOM BASE	ABS	1
18		DISK HOLDER	PVC	1
19		L.FIXED PLATE	SPCC	1
20		R.FIXED PLATE	SPCC	1
21		STAY R	SPCC	1
22		STAY L	SPCC	1
23		SWIVEL PLATE	SPCC	1
24		MAIN P.W.B. BRACKET	SPCC	1
25-1		FOOT (ABS,KURZ BM82361)	ABS	4
25-2		FOOT	EVA	4
26		LASER BEAM LABEL	PAPER	1
27		STEEL WIRE	SUS	1
28		MOTOR BELT	RUBBER	1
29		WASHER (HIMERON BLACK 18)	FELT	1
30		MAGNET (Φ30X18X5t,650Gm)	FERRITE	1
31		SCREW (TTP CAP M3X8mm)	SWCH	2
32		SCREW (SAE1018,BTP,Φ3X8)	SWCH	6
33		SCREW (M3X7 PTP)	SWCH	1
34		SCREW (M3X9mm PTP)	SWCH	1
35		SCREW (SAE1018,PTP,Φ2.6X8)	SWCH	1
36		SCREW (M2.6X4 P0.45)	SWCH	2
37		SCREW (PTP M3X14)	SWCH	1
38		SCREW (W BTP 2.6X6 MC)	SWCH	2
39		CD DOOR	ABS	1
40-1		SPIRAL GEAR	POM	1
40-2		SHAFT	CU	1
40-3	◆	MOTOR (MEN-7E2T5,DC12V)	COMPLEX	1
41		BRACKET TRANSFORMER	SPCC	2
42		POWER SWITCH BRACKET	SPCC	1
43		BUTTOM BASE	SPCC	1
44		BACK BOARD	SPCC	1
45		TOP COVER	PVC+SPCC	1
46	◆	POWER SW (SDDL B1017U-HF,2PIN)	COMPLEX	1
48		TRANSFORMER (AC230V)	COMPLEX	1
49	◆	AC CAPACITOR (0.01uF/250V,M,BULK,Y5V)	COMPLEX	1
50		TRANSFER SCREWS LABEL	PAPER	1
52		FUSE LABEL (46X6mm,y=0.08mm)	POLYESTER	1
53		CNR COVER (HU-13A-PRW)	PVC	1
54		PROTECTION MAT	CR FOAM	5
55-1		MOTOR PULLEY	PA	1
55-2	◆	MOTOR (MEN-7E2T5,DC12V)	COMPLEX	1
56		CUSHION (EVA,Φ31.3,t=1)	EVA	1
57		SCREW (SAE1018,BTP,Φ3X8)	SWCH	4
58		SCREW (3X5mm,BLACK)	SWCH	4
59		SCREW (TTB M3X10mm)	SWCH	1
60		SCREW (3X8mm)	SWCH	18
61		SCREW (TTB M3X12mm)	SWCH	4
62		SCREW (4X8mm TTB BLACK)	SWCH	2
63		SCREW (3X8)	SWCH	4
64		PC WASHER	PC	1
65		PC WASHER	PC	1

Exploded view of Main unit

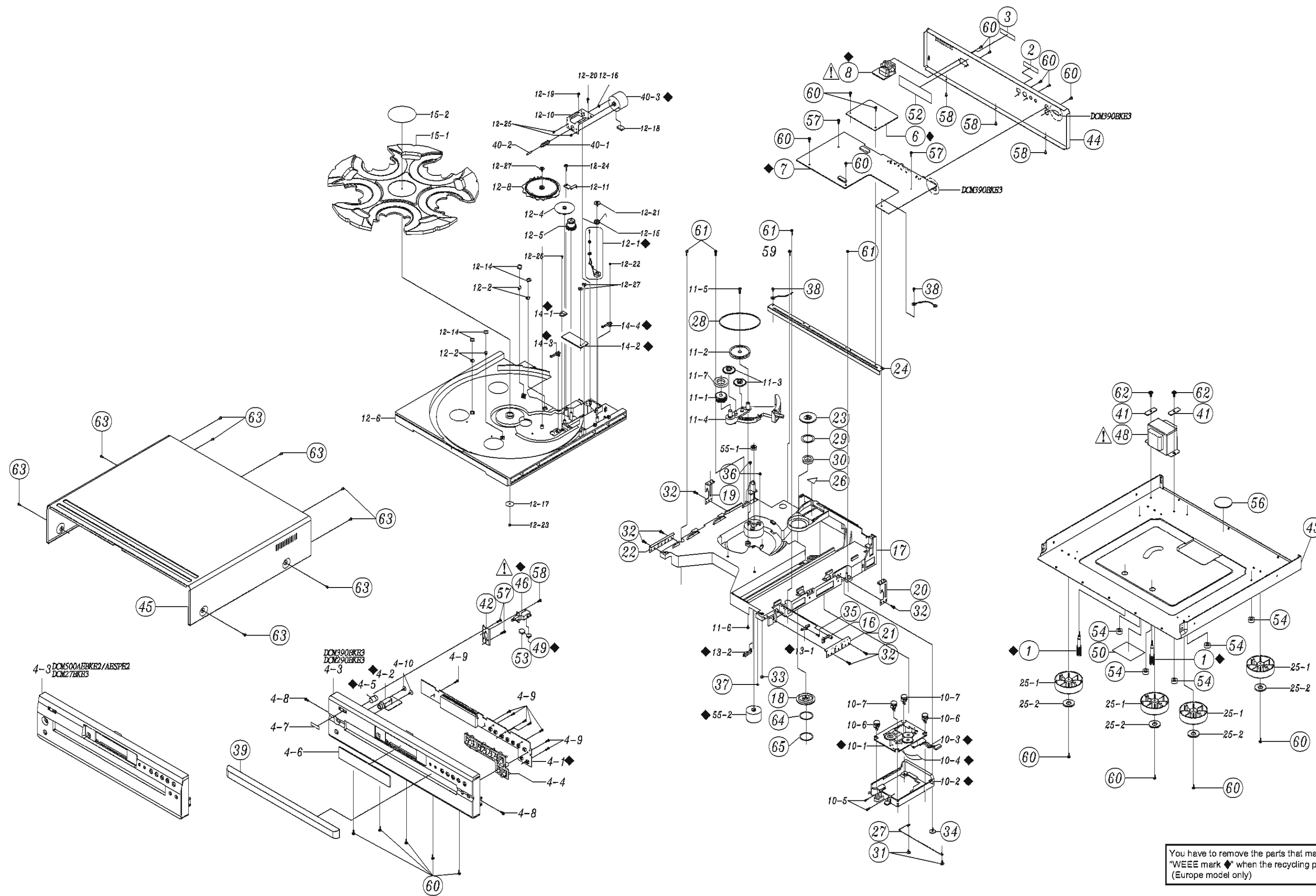

You have to remove the parts that marked "WEEE mark ◆" when the recycling processing. (Europe model only)

Details of Recycle parts for Power transformer

Part No.48

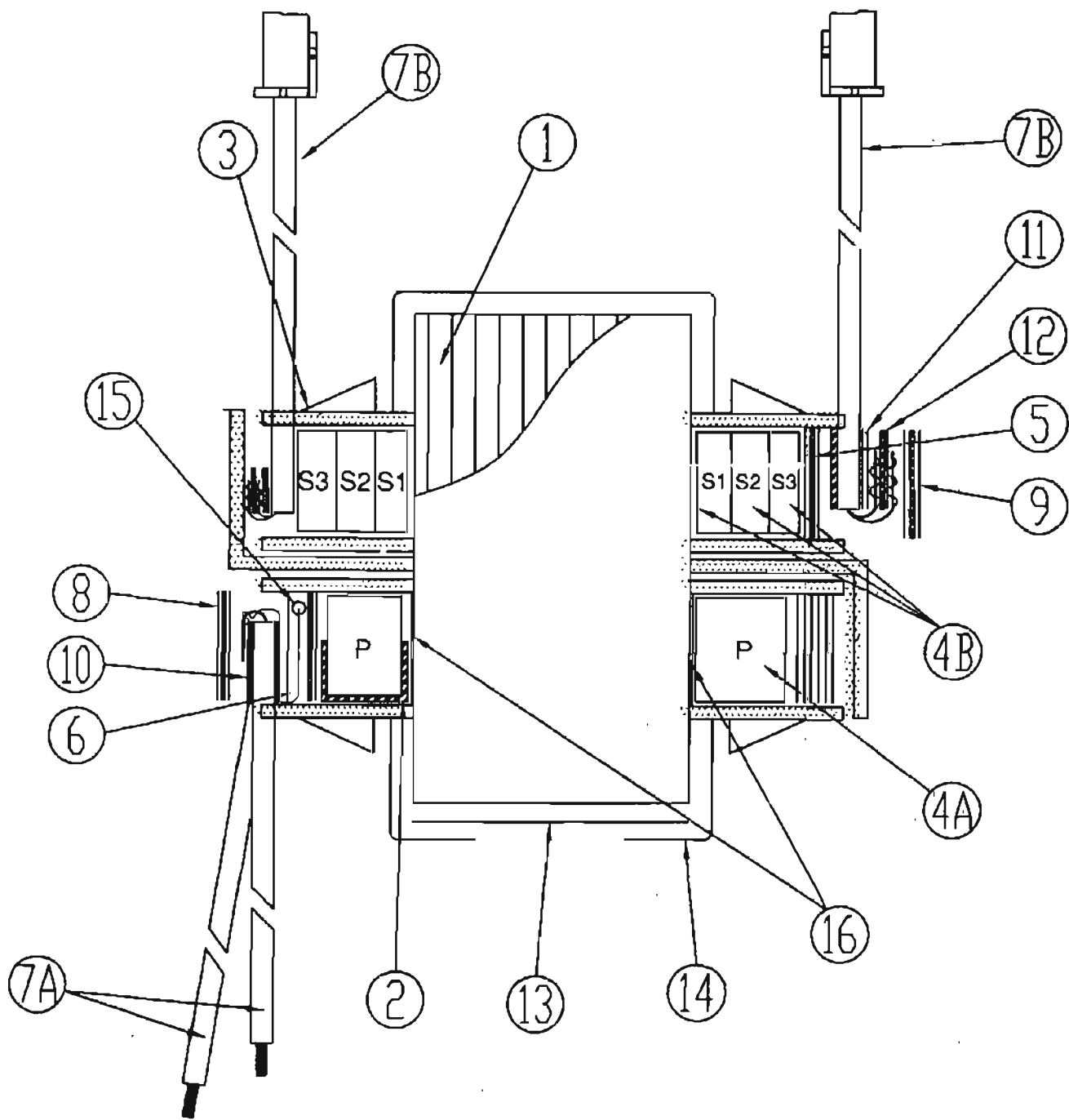

No.	Material
1	Silicon Steel
2	Acetate Cloth Tape
3	PBT
4A	PU
4B	Enamelled Copper Wire
5A	PE
5B	Press Board
6A	PE
6B	Press Board
7A	Copper Wire
7B	Copper Wire
8A	PE
8B	Press Board
9A	PE
9B	Press Board
10A	PE
10B	PVC
11A	PE
11B	PVC
12A	PE
12B	Press Board
13	Steel
14	Steel
15	Complex