

# DENON

For U.S.A., Canada, Europe, U.K.,  
Asia, China, Taiwan R.O.C., Korea  
& Japan model

**Ver. 1**

## SERVICE MANUAL

# MODEL DN-S1000

### TABLE TOP SINGLE CD PLAYER

#### 注 意

サービスをおこなう前に、このサービスマニュアルを必ずお読みください。本機は、火災、感電、けがなどに対する安全性を確保するために、さまざまな配慮をおこなっており、また法的には「電気用品安全法」にもとづき、所定の許可を得て製造されております。従ってサービスをおこなう際は、これらの安全性が維持されるよう、このサービスマニュアルに記載されている注意事項を必ずお守りください。

● For purposes of improvement, specifications and design are subject to change without notice.

● 本機の仕様は性能改良のため、予告なく変更することがあります。  
● 補修用性能部品の保有期間は、製造打切後8年です。

● Please use this service manual with referring to the operating instructions without fail.

● 修理の際は、必ず取扱説明書を参照の上、作業を行ってください。

● Some illustrations using in this service manual are slightly different from the actual set.

● 本文中に使用しているイラストは、説明の都合上現物と多少異なる場合があります。

## DENON, Ltd.

TOKYO, JAPAN

## SAFETY PRECAUTIONS

The following check should be performed for the continued protection of the customer and service technician.

### LEAKAGE CURRENT CHECK

Before returning the unit to the customer, make sure you make either (1) a leakage current check or (2) a line to chassis resistance check. If the leakage current exceeds 0.5 milliamps, or if the resistance from chassis to either side of the power cord is less than 460 kohms, the unit is defective.

### LASER RADIATION

Do not stare into beam or view directly with optical instruments, class 3A laser product.

**注意** サービス、点検時には次のことにご注意願います。

●注意事項をお守りください！

サービスのとき特に注意を必要とする個所については、キャビネット、部品、シャーシなどにラベルや捺印で、注意事項を表示しています。これらの注意書きおよび取扱説明書などの注意事項を必ずお守りください。

●感電に注意！

- (1) このセットは、交流電圧が印加されていますので、通電時に内部金属部に触れると感電することがあります。従って通電サービス時には、絶縁トランスの使用や手袋の着用、部品交換には、電源プラグを抜くなどして、感電にご注意ください。
- (2) 内部には、高電圧の部分がありますので、通電時の取扱には、十分ご注意ください。

●指定部品の使用！

セットの部品は難燃性や耐電圧など安全上の特性を持ったものとなっています。従って交換部品は、使用されていたものと同じ特性の部品を使用してください。特に配線図、部品表に△印で指定されている安全上重要な部品は必ず指定のものをご使用ください。

●部品の取付けや配線の引きまわしは、元どおりに！

安全上、テープやチューブなどの絶縁材料を使用したり、プリント基板から浮かして取付けた部品があります。また内部配線は引きまわしやクランプによって発熱部品や高圧部品に接近しないように配慮されていますので、これらは必ず元どおりにしてください。

●サービス後は安全点検を！

サービスのために取り外したねじ、部品、配線などが元どおりになっているか、またサービスした個所の周辺を劣化させてしまったところがないかなどを点検し、外部金属端子部と、電源プラグの刃の間の絶縁チェックをおこなうなど、安全性が確保されていることを確認してください。

(絶縁チェックの方法)

電源コンセントから電源プラグを抜き、アンテナや、プラグなどを外し、電源スイッチを入れます。500V絶縁抵抗計を用いて、電源プラグのそれぞれの端子と、外部露出金属部〔アンテナ端子、ヘッドホン端子、マイク端子、入力端子など〕との間で、絶縁抵抗値が1MΩ以上であること、この値以下のときは、セットの点検修理が必要です。

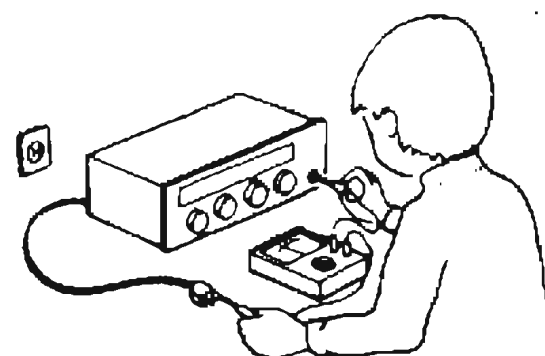

**注意** 安全上重要な部品について

本機に使用している多くの電気部品、および機構部品は安全上、特別な特性を持っています。この特性はほとんどの場合、外観では判別つきにくく、また、もとの部品より高い定格（定格電力、耐圧）を持ったものを使用しても安全性が維持されるとは、限りません。安全上の特性を持った部品は、このサービスマニュアルの配線図、部品表につぎのように表示していますので、必ず指定されている部品番号のものを使用願います。

(1)配線図… △マークで表示しています。

(2)部品表… △マークで表示しています。  
指定された部品と異なるものを使用した場合には、感電、火災などの危険を生じる恐れがあります。

## DISASSEMBLY

(Follow the procedure below in reverse order when reassembling.)

### 1. Bottom Plate

- (1) Remove 6 screws 57 and pull out Bottom Plate.

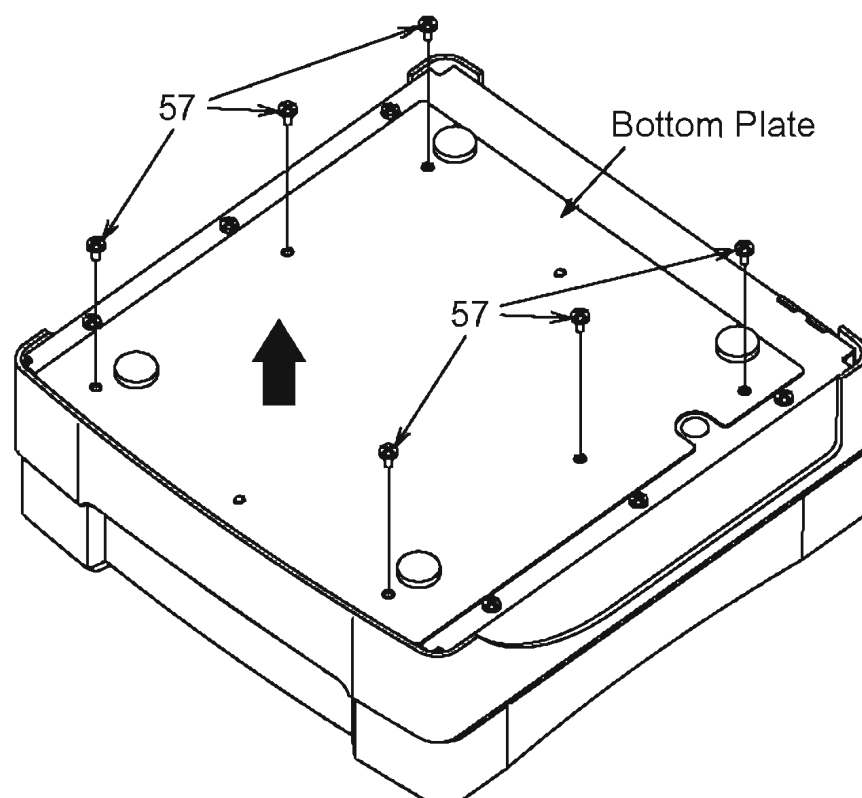

### 2. Top Cover unit

- (1) Remove 6 screws 61 and 2 screws 59.
- (2) Disconnect FFC Cable.
- (3) Detach Top Cover unit.

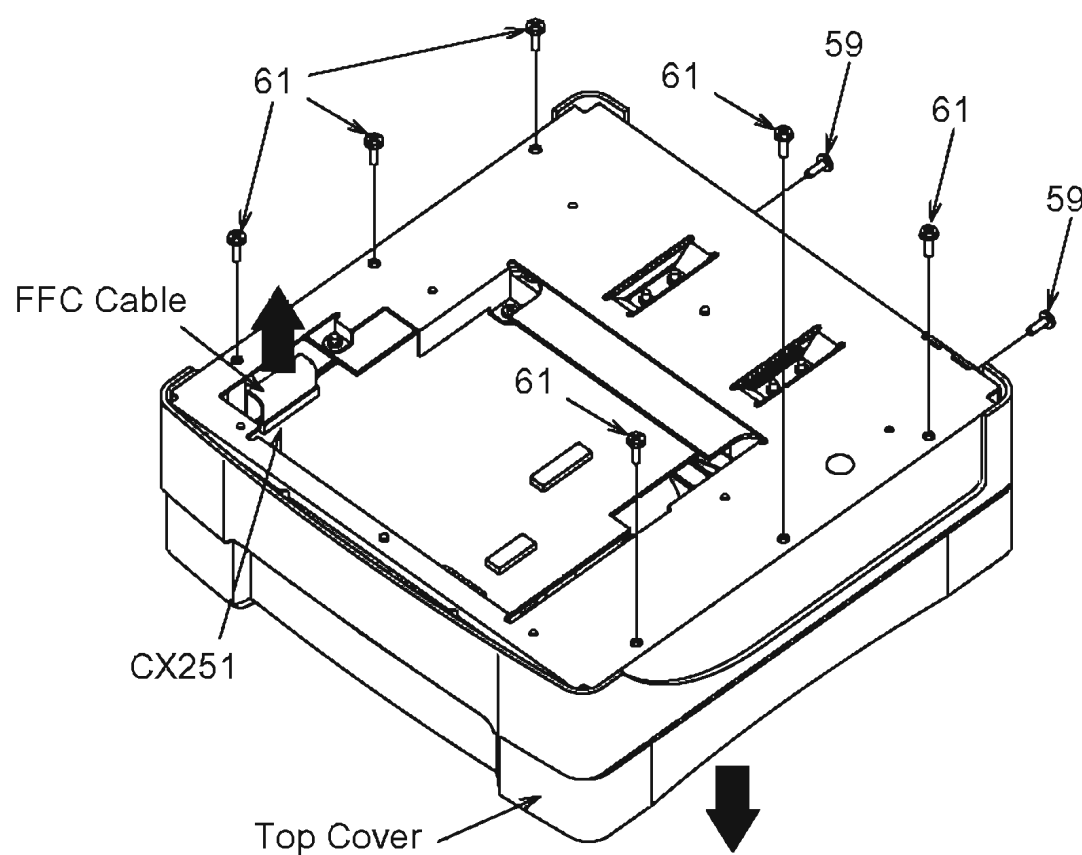

**Note:**

- Do not pull out aslant to prevent FFC cable damage.
- Do not fail to pull AC cord from wall outlet before disconnect FFC Cable.  
If AC cord is remained plugged into wall outlet, power is kept supplied in the unit, which may cause danger.

### 3. Shield Bracket

- (1) Remove 4 screws 58 and 2 screws 67.
- (2) Detach Shield Bracket.

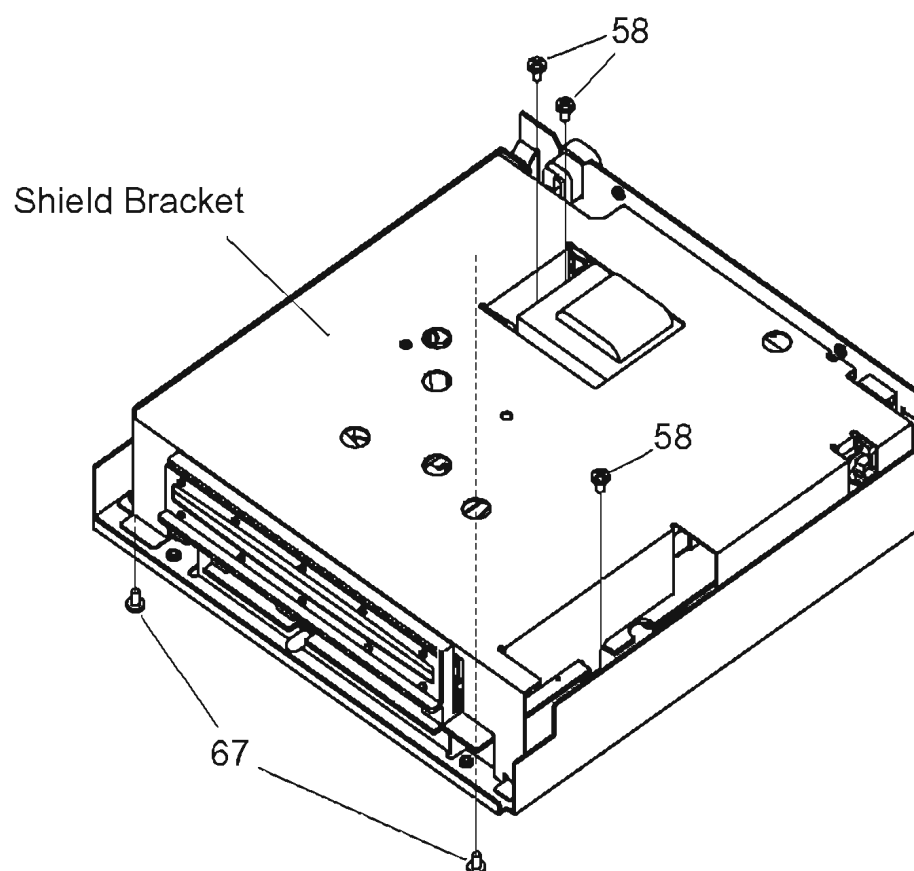

### 4. Mecha unit

- (1) Remove 2 screws 53 and 2 screws 55.
- (2) Disconnect FFC cable.
- (3) Detach Mecha Unit.

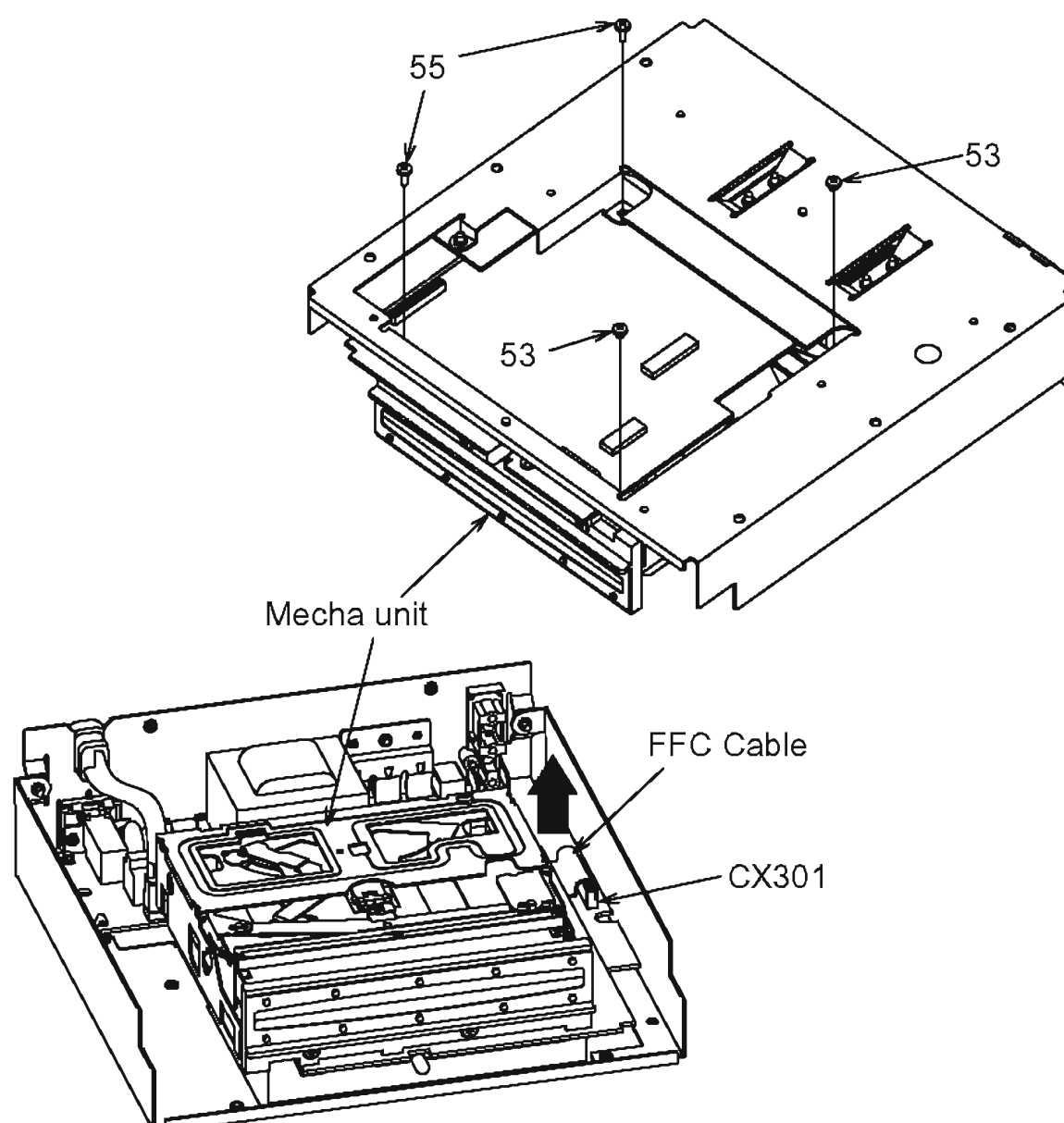

**Note:**

- Do not pull out aslant to prevent FFC cable damage.
- Do not fail to pull AC cord from wall outlet before disconnect the FFC cable.  
If AC cord is remained plugged into wall outlet, power is kept supplied in the unit, which may cause danger.

## 5. Power P.W.B.

- (1) Remove 5 screws 58, a screws 60 and a screws 61.
- (2) Detach Power P.W.B.

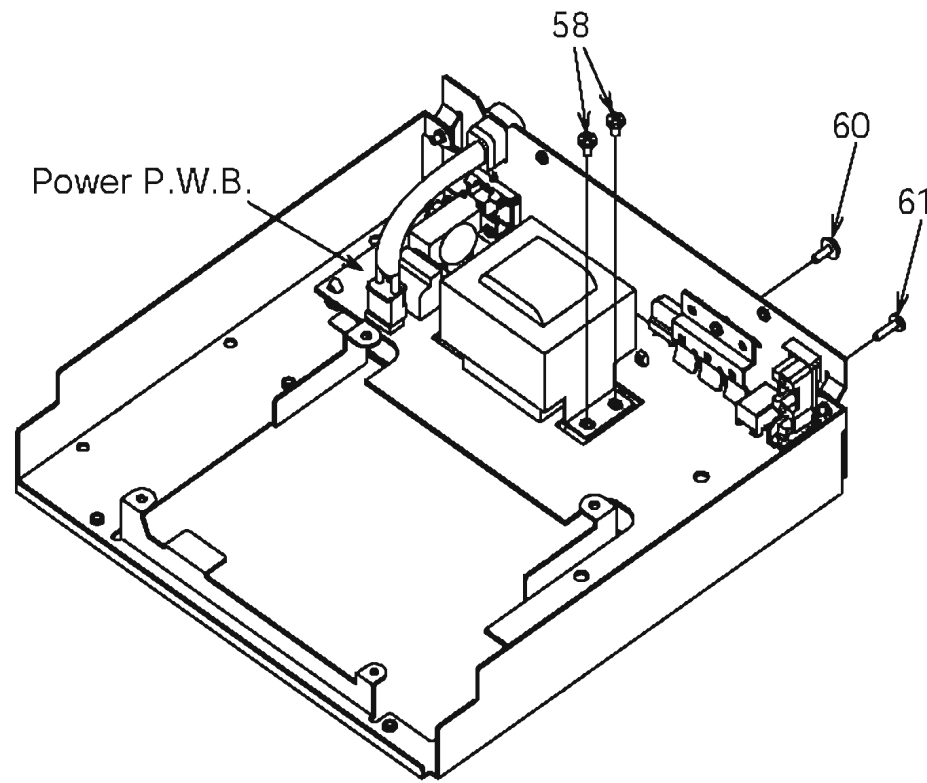

## 6. Main P.W.B.

- (1) Short-circuit the short land above.
- (2) Remove a screws 54 and a screws 56.
- (3) Disconnect FFC Cable and FPC Cable.
- (4) Detach Main P.W.B.

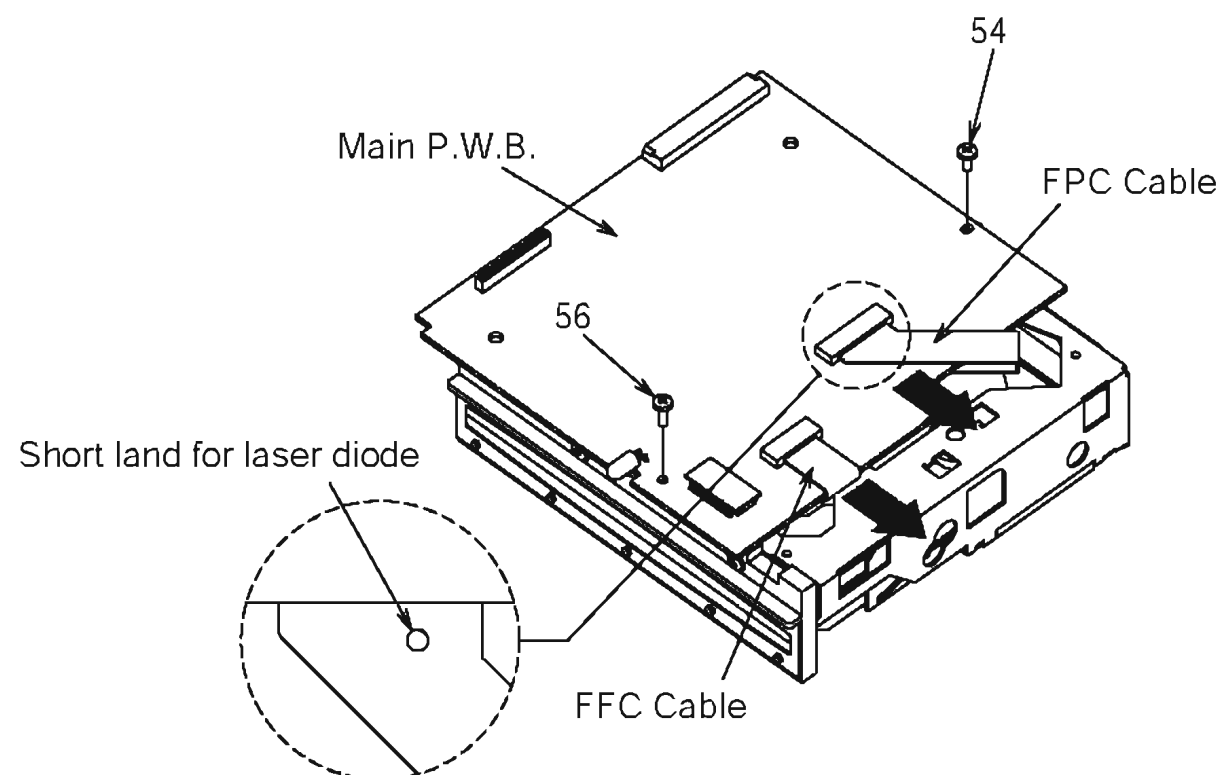

### Note:

- Do not pull out aslant to prevent FFC cable damage.

## 7. CD Mecha

- (1) Remove 2 screws 53 and pull out Main Pwb Bracket.
- (2) Remove 2 screws 55 and pull out Disc Guide.

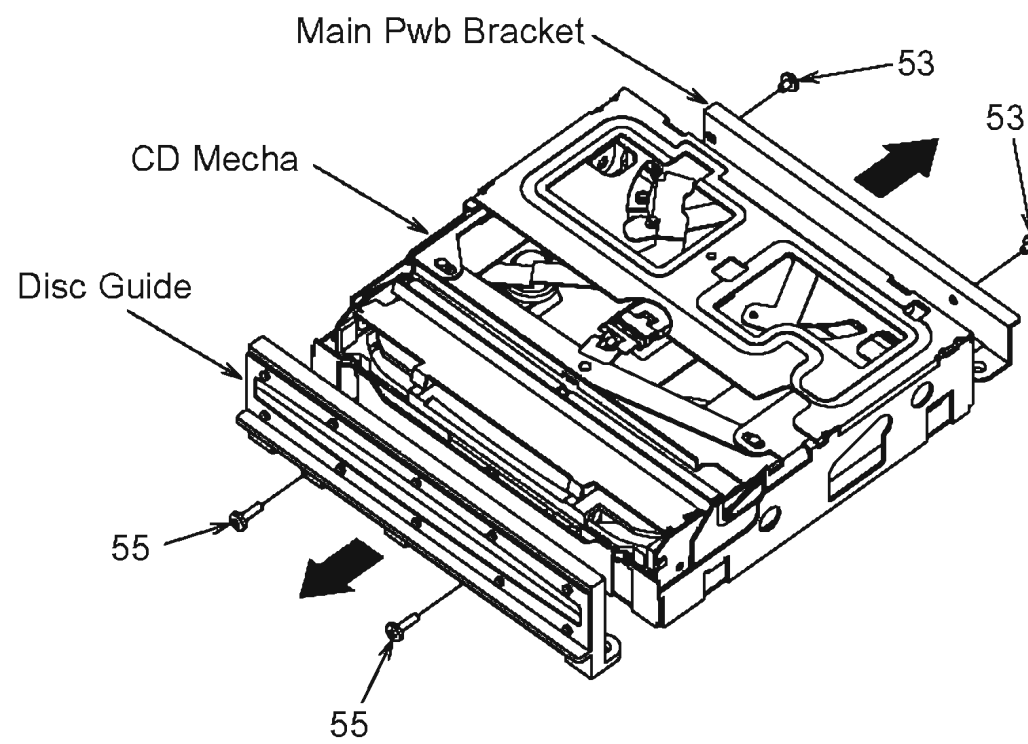

## 8. Scratch Disc unit

- (1) Remove a screws 66 and pull out Scratch Disc unit.

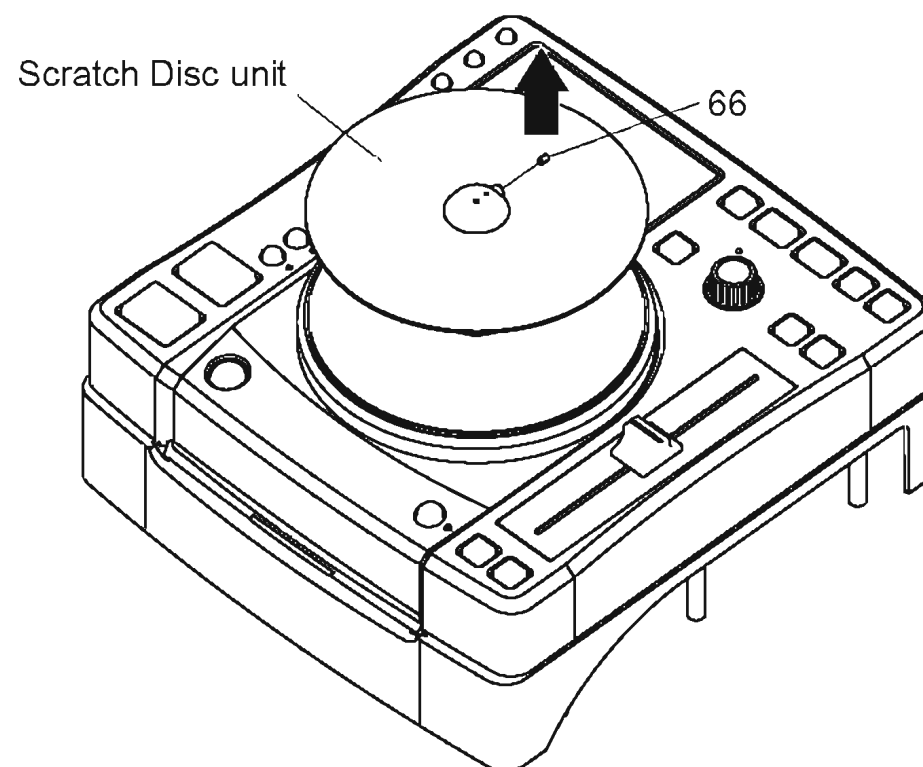

## 9. Disc Switch P.W.B.

- (1) Detach Slip mat, Anti-Static Sheet and Spring Plate.
- (2) Remove 4 screws 56.
- (3) Detach Disc Switch P.W.B.

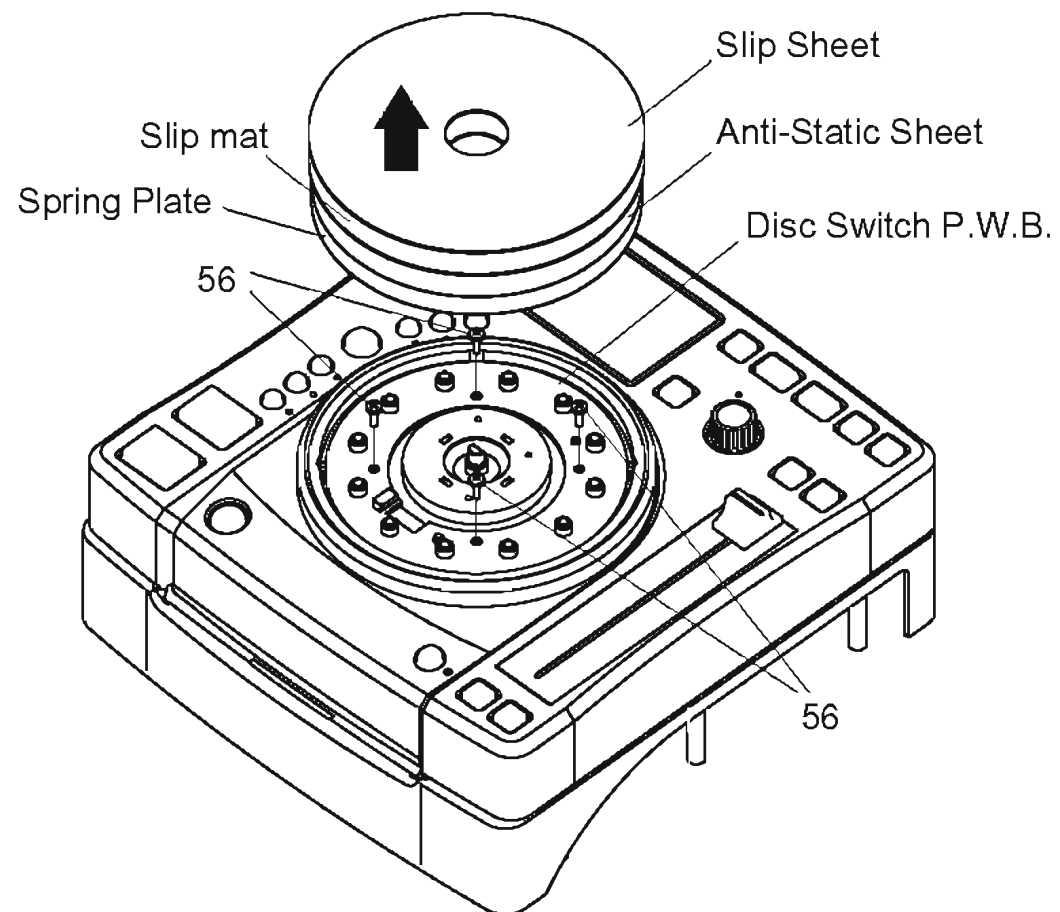

## 10. Sensor P.W.B. and Scale unit

- (1) Remove 2 screws 56 and pull out Sensor Cover and Sensor P.W.B.
- (2) Remove a screw 51 and pull out Scale unit.

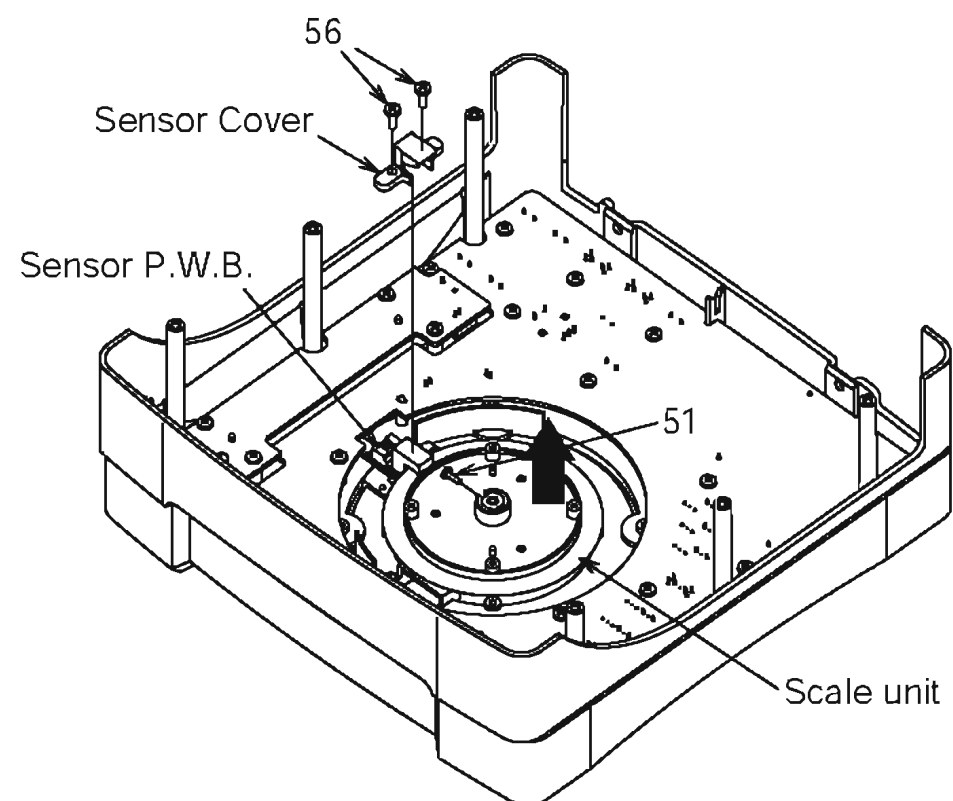

BLOCK DIAGRAM

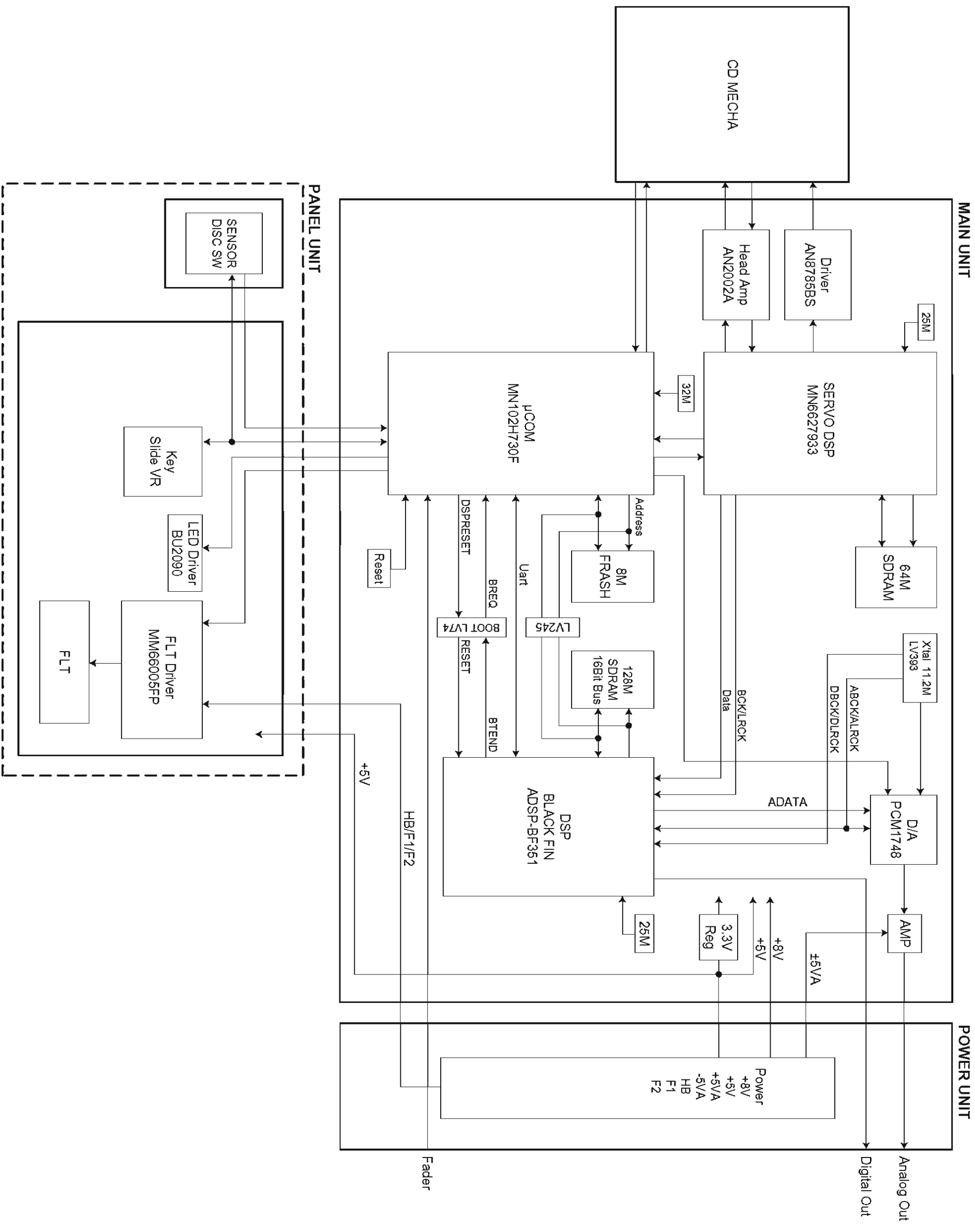



## CONFIRMING THE SERVO

### What is Service Program

Service program is a special program intended for confirming servo functions etc.  
This manual use both as DN-S1000 and DN-D6000

### Required Measuring Implement

Reference disc (TCD784 or CO-74176)

### 1. Contents of Service Program

Turn on the power while pressing both B button and the PARAMETER knob to set the service mode of DN-S1000. Turn on the power while pressing both PARAMETER knob of CD1 and "LOOP B" button of CD2 to set the service mode of DN-D6000. The various check items can be selected with the PARAMETER knob, the various test items can be selected with the A, B, SAMP and BEND buttons. Press either the PARAMETER knob or PLAY/PAUSE button to start the check or test and display the result.

To eject the disc, press the DISC EJECT button.  
To cancel the service mode, turn the power off.

Process No. (TRACK Indication)	Function (Character-display)	Contents
01	µcom Version check (Version No.)	A PARAMETER knob is pushed and a version is checked. 1. System µcom version No. : "Sys_XXXX" 2. DSP soft version No. : "Dsp_XXXX" 3. RC µcom version No. : "Rc_XXXX" (DN-D6000 only)
02	"TR_Signal" "HF_Signal"	Press the PARAMETER knob to turn the tracking servo off. When the tracking servo is off, press the PARAMETER knob to turn the tracking servo on. Press the PARAMETER knob to start automatic servo adjustment. When the adjustment is completed, the adjustment data is displayed. The data can be selected by turning the scratch disc. 1. Disc check, CD/CD-RW 2. Focus gain data 3. Focus balance data 4. Focus offset data 5. Tracking gain data 6. Tracking balance data 7. Tracking offset data 8. S curve maximum 9. S curve minimum
03	Automatic Servo Adjustment call (Servo Data)	
04	"Fo_Gain"	Select the focus gain. Default : 7. Select the data with the scratch disc, then press the PARAMETER knob to enter it. The higher the value, the higher the gain, while the lower the value, the lower the gain. * Do not change this without instruction from engineering.
05	"Tr_Gain"	Select the tracking gain. Default : 2. The operation is the same as for the Fo Gain.
06	"Block_Error"	The block error rate is displayed.
07	"PU_Clean"	When the PARAMETER knob is pressed, the pickup moves towards the outer edge of the disc. The pickup lens becomes visible through the slit in the CD mechanism plate. The lens can be cleaned using a cotton swab, etc. (Perform this operation with the top panel/cover removed and the disc ejected.) During normal operation, the error code for the error that occurred is displayed. Turn the disc to select up to 10 sets of error data stored in the memory. (See the error code table for a description of the error codes.) • Press the PARAMETER knob to set the error data clear mode. ("Err Clear?" is displayed.) Press the PARAMETER knob again to clear all the error data.
08	Error Code Check (Error Data)	
09	Total Running Time (Total Time)	The total operating time of the spindle motor is displayed. A total of 65,535 hours can be counted, in units of hours. NOTE: If the power is turned off after 59 minutes or less, that hour is not counted. • Press the PARAMETER knob to set the total time clear mode. ("Time Clear?" is displayed.) Press the PARAMETER knob again to clear the total time.

## サービスモード

### サービスモードについて

サービスモードは、サーボ状態などを確認するための特別なプログラムです。  
このマニュアルは DN-S1000、DN-D6000 兼用です。

### 確認に必要な測定器具

リファレンスディスク：TCD784、CO-74176

### 1. サービスプログラムの内容

DN-S1000 は B ボタンとパラメータダイヤルを両方押ししながら、電源を投入するとサービスモードになります。DN-D6000 は CD1 のパラメータダイヤルと CD2 の LOOP の B ボタンを押しながら電源を投入します。パラメータダイヤルで各チェック項目が、A ボタン、B ボタン、SAMP ボタン、または BEND ボタンで各項目が選択できます。パラメータダイヤルを押すか、PLAY/PAUSE ボタンを押すと各項目のチェック、テストを開始し、その結果を表示します。

ディスクをリジェクトするには、DISC EJECT ボタンを押します。  
サービスモードをキャンセルするには、電源を切ってください。

チェック項目 No. (トラック番号)	機能 キー操作-表示	内容
01	マイクロコンピュータ Version No	パラメータダイヤルを押して、バージョン番号を表示します。 1. システムマイクロコンピュータバージョン No. : "Sys_XXXX" 2. DSP ソフトウェアバージョン No. : "Dsp_XXXX" 3. RC マイクロコンピュータバージョン No. : "Rc_XXXX" (DN-D6000 のみ)
02	"TR_Signal" "HF_Signal"	パラメータダイヤルを押すとトラックサーボをオフにします。 トラックサーボがオフのとき、パラメータダイヤルを押すとトラックサーボをオンにします。 パラメータダイヤルを押すとサーボ自動調整を開始します。調整が終了すると、調整データを表示します。データはスクラッチディスクを回すことで選択できます。 1. ディスクチェック、CD/CD-RW 2. フォกัสゲインデータ 3. フォกัสバランスデータ 4. フォกัสオフセットデータ 5. トラッキングゲインデータ 6. トラッキングバランスデータ 7. トラッキングオフセットデータ 8. Sカーブ最大値 9. Sカーブ最小値
03	サーボ自動調整値 読み出し (Servo Data)	
04	"Fo_Gain"	フォーカスを選択します。デフォルトは 7。スクラッチディスクでフォーカスを選択し、パラメータダイヤルを押すと確定されます。数値が大きくなるとフォーカスが高くなり、数値が小さくなるとフォーカスが低くなります。 * 設計からの指示がない限り変更しないで下さい。
05	"Tr_Gain"	トラッキングを選択します。デフォルトは 2。操作方法は Fo Gain と同じ。
06	"Block_Error"	ブロックエラー率が表示されます。
07	"PU_Clean"	パラメータダイヤルを押すとピックアップがディスクの外周方向へ移動します。CD 基板の隙間からピックアップのレンズが見えるようになります。綿棒等でレンズをクリーニングすることができ ます。 (トップパネル/カバーを外し、ディスクをリジェクトした状態で実施下さい)
08	エラーコードチェック (Error Data)	通常動作時、発生したエラーコードが表示されます。データを回すと、最大 10 個まで、記憶されたエラーコードが選択できます。(エラーコードはエラーコード表を参照下さい。) • パラメータダイヤルを押すと、エラーコードが消去モードになります。(Err Clear? が表示されます) 再度、パラメータダイヤルを押すと、全てのエラーコードが消去されます。
09	トータルランニングタイム (Total Time)	スピンドルモーターの動作時間を表示します。1 時間単位で 65535 時間まで計測できます。 注意) 59 分以下で電源を切るとカウントされません。 • パラメータダイヤルを押すと、トータル時間消去モードになります。(Time Clear? が表示されます) 再度、パラメータダイヤルを押すと、トータル時間が消去されます。

CUE button FLT all light check performed while button pressed.  
 BEND+ button FLT all off check performed while button pressed.  
 BEND- button Disc eject status set while button pressed.

The disc loading/eject roller turns. The dirt can be cleaned off the roller by gently pressing a cotton swab with "isopropyl alcohol", against the roller.  
 (Perform this operation with the top panel/cover removed and the disc ejected.)

Servo automatic adjustment read-out value

Adjustment Item	Adjustment Value Indication at character portions.
1 Focus Gain	0408 ~ 3248
2 Focus Balance	-50 ~ +50
3 Focus Offset	-005 ~ +005
4 Tracking Gain	0392 ~ 1569
5 Tracking Balance	-025 ~ +025
6 Tracking Offset	-005 ~ +005

## 2. TEST MODE

Function (Character-display)	Contents
A button Heat Run Test H/R1 Normal	Press button A1, then press the PLAY/PAUSE button to start the test. The disc is ejected, loaded and played repeatedly. For discs containing 20 tracks or less, all the tracks are played. For discs containing 21 tracks or more, only the first and last tracks on the disc are played. If an error occurs, the error code is displayed and the stop mode is set.
A2 button Chucking Test H/R2 Tray	Press button A2, then press the PLAY/PAUSE button to start the test. The disc load/eject servo input and TOC reading operations are performed repeatedly. If an error occurs, the error code is displayed and the stop mode is set.
SAMP button System check Sys. Check	Press button EXIT/RELOOP, then press the PLAY/PAUSE button to start the system check. Once the check is completed, the results are displayed. 1. The system ucom and DSP communications are checked. 2. Reading and writing SDRAM of DSP are checked. 3. Reading and writing SDRAM of servo DSP are checked. 4. Communications between the system ucom and servo DSP are checked. 5. The CD drive operation is checked. (Inner edge switch detection is performed.) 6. The CD drive operation is checked. (Disc detection is performed.) Once all the checks are completed, the results are displayed on the character display. The numbers of the checks in items 1 to 6 above that were OK are displayed. If one of the checks was not OK, the number of that item is not displayed.

## 3. Error Code Table (Appears only at Heat Run and Chucking Test function)

Error Code	Contents
Automatic Adjustment Error	
E1 00	Unable to detect disk
E1 01	Unable to adjust tracking offset
E1 03	Unable to adjust focus fine gain
E1 04	Unable to actuate focus
E1 05	Unable to actuate tracking
E1 06	Unable to adjust tracking fine gain
E2 02	Servo down during automatic Adjustment
E3 00	Unable to read TOC
E4 00	Unable to close the disc holder in the regular time
E4 01	Unable to open the disc holder in the regular time
E5 00	The inner SW dose not turn on
E5 01	Slider error
E5 02	The inner SW dose not turn off

CUE ボタン ボタンを押している間、FLTの全点灯エッジを行います。  
 BEND+ ボタン ボタンを押している間、FLTの全消灯エッジを行います。  
 BEND- ボタン ボタンを押している間、ディスクを eject 状態にします。

ディスクローディング/エッジエッジ用のローラーが回転しますので、ソフトロビノリコーンが付けた綿棒をローラーに軽く押し当てることにより、ローラーの汚れを落とすことができます。  
 (トップパネル/カバーを外し、ディスクを eject した状態で実施下さい)

サーボ自動調整読み出し値

サーボ調整項目	調整 OK 範囲
1 フォーカスゲイン	0408 ~ 3248
2 フォーカスバランス	-50 ~ +50
3 フォーカスオフセット	-005 ~ +005
4 トラッキングゲイン	0392 ~ 1569
5 トラッキングバランス	-025 ~ +025
6 トラッキングオフセット	-005 ~ +005

## 2. テストモード

機能エッジ表示	内容
A ボタン ヒートランテスト H/R1 Normal	A1 ボタンを押して、PLAY/PAUSE ボタンを押すとテストを開始します。 ディスクの出し入れと、再生を繰り返します。 20トラック以下のディスクのときは、全てのトラックを再生します。 21トラック以上のディスクのときは、ディスク先頭トラックと最終トラックのみ再生します。エラーが発生すると、エラーコードを表示して停止します。
A2 ボタン チャッキングテスト H/R2 Load	A2 ボタンを押して、PLAY/PAUSE ボタンを押すとテストを開始します。 ディスクの出し入れと、サーボ投入、TOCの読み込みを繰り返します。 エラーが発生すると、エラーコードを表示して停止します。 EXIT/RELOOP ボタンを押して、PLAY/PAUSE ボタンを押すとエラーエッジを開始し、エッジ終了後、その結果を表示します。
SAMP ボタン システムチェック Sys. Check	1. システムucomとDSPの通信エッジを行います。 2. DSPのSDRAMのリード/ライトエッジを行います。 3. サーボDSPのSDRAMのリード/ライトエッジを行います。 4. システムucomとサーボDSPの通信エッジを行います。 5. CDドライブの動作エッジを行います。(内周SWの検出をおこないます。) 6. CDドライブの動作エッジを行います。(ディスク検出をおこないます。) 全てのエッジが終了すると、エッジ表示は結果を表示します。1～6項目のエッジがOKの時は、OKになった項目の番号が表示されます。NGの項目が含まった場合、NGになった項目の番号が表示されません。

## 3. エラーコード表 (ヒートラン、及び、チャッキングテストのとき表示されます)

エラーコード	内容
サーボ自動調整エラー	
E1 00	ディスクを検出できません。
E1 01	トラックエッジオフセットが調整できません。
E1 03	フォーカスゲインが調整できません。
E1 04	フォーカスサーボが入らない。
E1 05	トラックエッジサーボが入らない。
E1 06	トラックエッジサーボが調整できません。
E2 02	サーボ自動調整中サーボが外れた。
E3 00	TOCが規定時間内に読めない。
E4 00	ディスクが規定時間内にディスクアウトできません。
E4 01	ディスクが規定時間内にディスクアウトできません。
E5 00	内周SWONしない
E5 01	スライダーエラー
E5 02	内周SWOFFしない

Error Indication				
TR	MIN	SEC	FRAM	CHARACTER
displays the track No. in which error occurred.	Displays the time at which error occurred.			H * * * * * Operation count E * * * * * Error code

#### 4. ucom update

With the DN-S1000 and DN-D6000, the system ucom and DSP can be updated from a disc.

##### (1) Creating the update disc

Use the procedure described below to create the disc for updating the system microprocessor and DSP.

- Store the update file on a CD-R or CD-RW disc in ISO9660 Mode 1 format, then finalize the disc.
  - Write the distributed update files using the "DISC AT ONCE" CD writing software and finalize.
  - Do not record any other software or data on the disc containing the update software.
  - Do not change the file names - use the file names as distributed.

##### (2) Updating the system ucom and DSP

- Turn on the power and load the disc created in (1) above.

When the update disc is detected, "Version Up" is displayed. And "xxxx → yyyy" and "Push Play" are displayed by turns.

xxxx : Old Version No., yyyy : New Version No.

- Press the PLAY/PAUSE button. "NowLoading" is displayed and the updating procedure starts.

As updating proceeds, the playback position indicator lights in order from left to right.

NOTE: In some extremely rare cases, the updating procedure is not completed. If the updating procedure has not finished after three minutes, there could be a problem. Turn off the power and repeat the operation from step (2) ①.

- Depending on the problem that occurred, it may happen that no other operations can be performed. If this happens, GU-3607 IC102 must be replaced. Software must be pre-recorded on the IC102. (When ordering the IC102, order the more recent system microprocessor version number (GEN number).)

- When updating is completed, "Complete!" is displayed and the disc is ejected.

\* For DN-D6000, this operation must be performed for both CD1 and CD2.

エラー表示				
トラック	分	秒	フレーム	キャラクター
エラーが発生したトラック番号	エラーが発生した時間 (A/A/A)			H * * * * * 動作回数 E * * * * * エラーコード

#### 4. エラーメッセージ

DN-S1000、DN-D6000 は、エラーから、エラーメッセージ、DSP のメッセージを行うことができます。

##### (1) メッセージの作成

メッセージ、DSP のメッセージ用のデータを下記に従って作成する。

- メッセージ用のメッセージ、CD-R、又は CD-RW をそれぞれ ISO9660, MODE1 のフォーマットで記録し、フォーマットする。
  - 配布されたメッセージ、CD ライティングソフトで DISC AT ONCE で書き込みしフォーマットする。
  - メッセージ用のメッセージ以外のメッセージを同一メッセージ内に記録しないこと。
  - メッセージ名は、配布されたときのメッセージ名をそのまま使用すること。

##### (2) エラーメッセージ

- 電源を投入し、(1) で作成したメッセージをロードします

メッセージ用のメッセージが検出されると、"Version Up" と表示し、"xxxx → yyyy"、"Push Play" の交互表示になります。

xxxx : 旧バージョン No.、yyyy : 新バージョン No.

- PLAY/PAUSE ボタンを押すと、"NowLoading" を表示しメッセージを開始します。

メッセージの進行に合わせて、再生位置表示が左から右へ順に点灯します。

注意) 大抵希ではありますが、メッセージ中に、メッセージが終了の異常状態が発生することがあります。メッセージを開始し 3 分を経過しても終了しない場合も、異常が発生したと考えられますので、電源を切つて、再度、(2) ①から同一の操作を行つて下さい。

発生した異常状況により、以後の全ての動作が出来なくなることがあります。その場合、GU-3607 IC102 の交換が必要になります。IC102 は、予め、メッセージを書き込みする必要があります。(IC102 を発注の際は、最新のシステムメッセージのバージョン No (GEN No) で発注願います。)

- メッセージが終了すると、"Complete" を表示しメッセージがリセットされます。

\* DN-D6000 は、CD1、CD2 個々に実施する必要があります。

## SEMICONDUCTORS / 半導体一覧表

Only major semiconductors are shown, general semiconductors etc. are omitted to list.  
 主な半導体を記載しています。汎用の半導体は記載を省略しています。

### 1. IC's

#### MN102H730F (IC101)

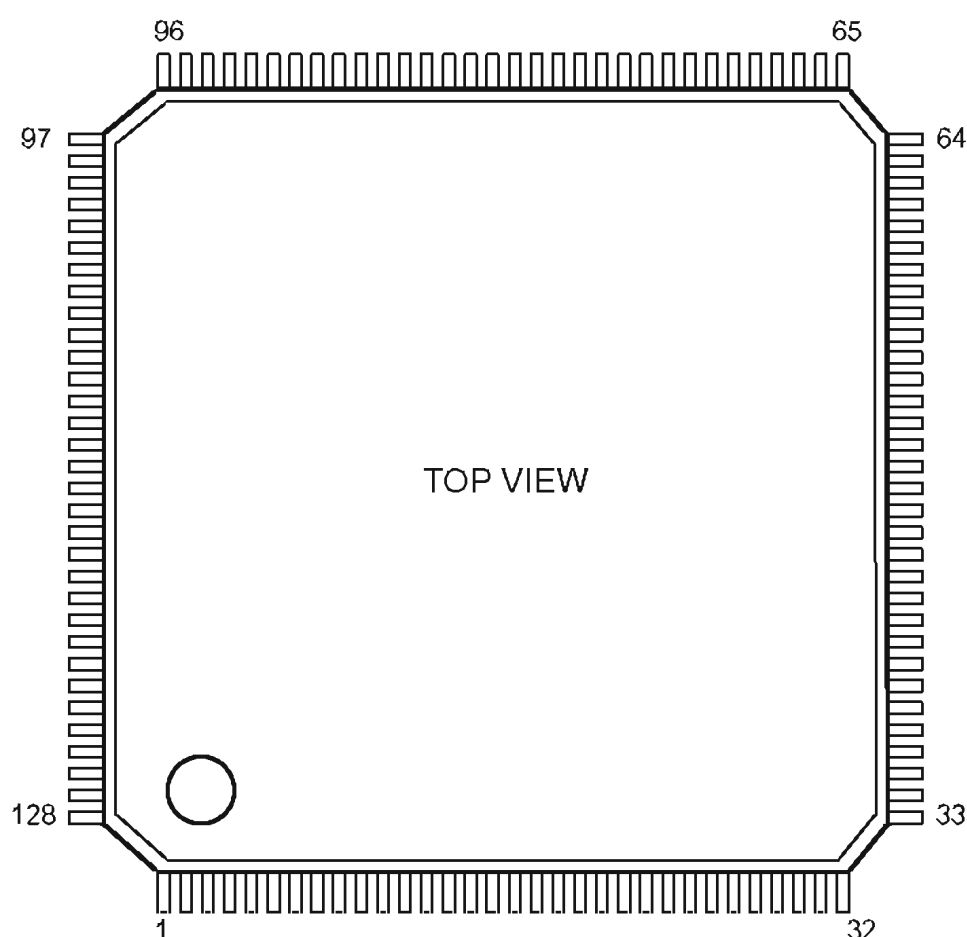

#### MN102H730F Terminal Function

Pin No.	Pin Name	Symbol	I/O	DET	Ext	Ini	Res	Function
1	CS0_	CS0_	O	-	Pu	-	-	Ext. memory chip select 0 (Frash ROM CS)
2	CS1_	CS1_	O	-	-	-	-	Not used
3	D00	DQ0	I/O	-	-	-	-	Ext. memory data I/O 0, DSP interface 0
4	D01	DQ1	I/O	-	-	-	-	Ext. memory data I/O 1, DSP interface 1
5	D02	DQ2	I/O	-	-	-	-	Ext. memory data I/O 2, DSP interface 2
6	D03	DQ3	I/O	-	-	-	-	Ext. memory data I/O 3, DSP interface 3
7	VDD	VDD	-	-	-	-	-	Power (+3.3V)
8	VSS	VSS	-	-	-	-	-	GND
9	D04	DQ4	I/O	-	-	-	-	Ext. memory data I/O 4, DSP interface 4
10	D05	DQ5	I/O	-	-	-	-	Ext. memory data I/O 5, DSP interface 5
11	D06	DQ6	I/O	-	-	-	-	Ext. memory data I/O 6, DSP interface 6
12	D07	DQ7	I/O	-	-	-	-	Ext. memory data I/O 7, DSP interface 7
13	D08	DQ8	I/O	-	-	-	-	Ext. memory data I/O 8, DSP interface 8
14	D09	DQ9	I/O	-	-	-	-	Ext. memory data I/O 9, DSP interface 9
15	D10	DQ10	I/O	-	-	-	-	Ext. memory data I/O 10, DSP interface 10
16	PD0,DMAACK1_	DLED	O	-	Pu	H	-	Disc LED
17	PD1,DMAREQ1_	DSPF3	O	-	-	L	-	Flag 3 for DSP (RESERVE)
18	D11	DQ11	I/O	-	-	-	-	Ext. memory data I/O 11, DSP interface 11
19	D12	DQ12	I/O	-	-	-	-	Ext. memory data I/O 12, DSP interface 12
20	D13	DQ13	I/O	-	-	-	-	Ext. memory data I/O 13, DSP interface 13
21	D14	DQ14	I/O	-	-	-	-	Ext. memory data I/O 14, DSP interface 14
22	D15	DQ15	I/O	-	-	-	-	Ext. memory data I/O 15, DSP interface 15
23	WORD	WORD	I	-	-	-	-	Data bus width select (H: 16bit), GND fixed
24	VDD	VDD	-	-	-	-	-	Power (+3.3V)
25	MODE	MODE	I	-	-	L	L	Processor mode, GND fixed
26	PC3	MODEL	I	-	Pu	L	-	RESERVE
		MODEL	I	-	Pd	L	-	RESERVE
27	XI	XI	I	-	-	-	-	Oscillation input
28	XO	XO	O	-	-	-	-	Oscillation output

Pin No.	Pin Name	Symbol	I/O	DET	Ext	Ini	Res	Function
29	VDD	VDD	-	-	-	-	-	Power (+3.3V)
30	OSCI	OSCI	I	-	-	-	-	Oscillation input, 32.0MHz
31	OSCO	OSCO	O	-	-	-	-	Oscillation output
32	VSS	VSS	-	-	-	-	-	GND
33	P57,BOSC	RESERVE	O	-	-	L	-	TP
34	PC5,NMI_	NMI	I	-	-	-	-	Connect to Power
35	RST_	RST_	I	-	-	-	-	µcom reset
36	PC0	_MUTE	O	-	Pd	L	L	Mute signal (L: Mute)
37	P76	RESERVE	O	-	-	L	-	TP
38	P60,IRQ0	DTIME	I	-	Pu	H	H	X2: Clock for playback interrupt input / X1: LRCK
39	P61,IRQ1	BLKCK	I	-	iPu	-	-	Sub cord clock interrupt
40	P62,IRQ2,TM10IOA	LOAD	O	-	-	Hi-Z	-	Disc roading, eject signal (PWM output)
41	P63,IRQ3,TM10IOB	DQSY	I	-	iPu	-	-	CD-TEXT DQSY interrupt
42	P64,IRQ4	DTIMES	I	-	Pu	H	H	X2: Sampler clock for playback interrupt input / X1:
43	P65,IRQ5,TM12IOA	DISCA	I	-	-	-	-	Disc for scratch pulse A count input
44	P66,IRQ6	DISCDIR	I	-	(Pu)	H	H	Scratch disc detect round direction interrupt input
45	P67,IRQ7	DISCINT	I	-	(Pu)	H	H	Disc round start interrupt input
46	P70,TM13IOB	DISCPA	I	-	(Pu)	H	H	Pulse width for scratch disc gauge input
47	P71	ML	O	-	iPu	Hi-Z	-	D/A interface scratch
48	PD2,DMAACK0_	CHGOFT	O	-	Pu	L	H	Off-track signal (Transistor drive)
49	PD3,TM3IO	DISCPA_	I	-	-	-	-	Disc for scratch pulse A reverse phase count input
50	VDD	VDD	-	-	-	-	-	Power (+3.3V)
51	P77	RESERVE	O	-	-	L	-	TP
52	P72,TM14IOB	DISCPB	I	-	-	-	-	Disc for scratch pulse B count input
53	P73	_NRES	O	-	Pd	L	L	IC reset signal
54	P74	MLD	O	-	-	H	-	Servo DSP interface latch
55	P75,TM12IOB	DCLK	I	-	-	-	-	Clock input for pulse width gauge for disc (5.6MHz)
56	PA0,SBI0	STAT	I	-	iPu	-	-	Servo DSP interface receive (clock sync)
57	PA1,SBO0	MDAT	O	-	-	H	-	Servo DSP interface send (clock sync)
58	PA2,SBT0	MCLK	O	-	-	H	-	Servo DSP interface clock (clock sync)
59	PA3,SBI1	RXDCD	I	-	Pu	-	-	Mecha. between interface receive (UART)
60	PA4,SBO1	LEDCLK1	O	-	Pu	H	H	DNS1000: LED driver (BU2090) clock 1 for data send
		TXDCD	O	-	Pu	H	-	DND6000: Mecha. between interface receive (UART)
61	PA5,SBT1	_DSTBY	O	-	Pd	L	L	Driver standby signal L: standby
62	PB0,SBI2	DSPTXD(RXD)	I	-	Pu	-	-	DSP interface receive (UART)
63	PB1,SBO2	DSPRXD(TXD)	O	-	Pu	H	H	DSP interface send (UART)
64	PB2,SBT2	_FLCS	O	-	Pu	H	H	DNS1000: FLT driver enable signal
65	PB3,SBI3	RXDRC	I	-	-	-	-	DND6000: RCD 60 interface receive (UART)
66	PB4,SBO3	PDATA	O	-	Pu	H	-	DNS1000: FLT driver (M66005A) data, LED driver data (clock sync)
		TXDRC	O	-	Pu	H	-	DND6000: RCD interface send (UART)
67	PB5,SBT3	FLCLK	O	-	-	H	-	DNS1000: FLT driver (M66005A) clock for data send (clock sync)
		RESERVE	O	-	-	H	-	DND6000: RESERVE
68	VDD	VDD	-	-	-	-	-	Power (+3.3V)
69	VSS	VSS	-	-	-	-	-	GND
70	AVSS	AVSS	-	-	-	-	-	Analog ref. GND for A/D conversion, GND
71	Vref-	Vref-	-	-	-	-	-	Analog ref. V for A/D conversion, GND
72	P80	_FLRES	O	-	Pd	L	L	DNS1000: FLT driver (M66005A) reset signal
73	P81	CSKSEL	O	-	Pd	H	L	L: Servo DSP D/A clock select
74	P82	LEDCLK2	O	-	Pu	H	H	DNS1000: LED driver (BU2090) clock 2 for data send
		RESERVE	I	-	Pu	-	-	DND6000: RESERVE (connect to RXDCD)
75	P83	SEL_A	O	-	-	L	-	DNS1000: Key scan output select signal A
76	P84	SEL_B	O	-	-	L	-	DNS1000: Key scan output select signal B
77	P85	SEL_C	O	-	-	L	-	DNS1000: Key scan output select signal C
78	P86,AD06	PITCH	I	-	-	-	-	DNS1000: Slid VR for pitch data input
79	P87,AD07	PITCHC	I	-	-	-	-	DNS1000: Slid VR for pitch center value data input

Pin No.	Pin Name	Symbol	I/O	DET	Ext	Ini	Res	Function
80	PD4	KIN0	I	-	Pu	-	H	DNS1000: Key scan input signal 0
		EJECT	I	-	Pu	-	H	DND6000: Disc eject button input signal
81	PD5	KIN1	I	-	Pu	-	H	DNS1000: Key scan input signal 1
		CDSEL	I	-	Pu	-	H	DND6000: CD mecha. Select H: CD1, L: CD2
82	P90	KIN2	I	-	Pu	-	H	DNS1000: Key scan input signal 2
83	P91	KIN3	I	-	Pu	-	H	DNS1000: Key scan input signal 3
84	P92	_LSSW	I	-	iPu	-	-	Disc input detect SW L: Disc in
85	P93	_PISW	I	-	iPu	-	-	Inner switch L: Switch ON
86	Vref+	Vref+	-	-	-	-	-	Analog ref. V for A/D conversion, +3.3V
87	AVDD	AVDD	-	-	-	-	-	Power (+3.3V)
88	P94	DSENS	I	-	iPu	-	-	Disc sensor 12/8 cm disc detect L: 12cm disc
89	P95	_CSW	I	-	iPu	-	-	Loading switch L: Switch ON
90	P96,DAC2	DSPF0	O	-	-	L	-	Flag 0 for DSP (RESERVE)
91	P97,DAC3	_DSPRES	O	-	Pd	L	L	DSP reset signal L: RESET
92	PC6,BREQ_	_BREQ	I	-	Pu	-	H	Bus request signal
93	PC7,BRACK_	_BRACK	O	-	Pu	H	H	Bus request accept signal
94	WEL_	WE_	O	-	Pu	-	H	Ext. memory write enable (Lower 8 bit)
95	P51	_BOOT	O	-	Pu	H	H	DSP boot start signal L: START
96	RE_	RE_	O	-	Pu	-	H	Ext. memory read enable
97	CS2_	CS2_	O	-	-	-	-	Ext. memory chip select 2 (Not used)
98	VDD	VDD	-	-	-	-	-	Power (+3.3V)
99	VSS	VSS	-	-	-	-	-	GND
100	P54,BSTRE	FPLAY	I	-	Pu	H	H	Fader start PLAY input
101	P55,WR_	FCUE	I	-	Pu	H	H	Fader start CUE input
102	CS3_	CS3_	O	-	-	-	-	Not used
103	A00	A00	O	-	-	-	-	Ext. memory address 0 (16 bit bus select : not used)
104	A01	A01	O	-	-	-	-	Ext. memory address 1 (16 bit bus select : not used)
105	A02	A02	O	-	-	-	-	Ext. memory address 2 (16 bit bus select : not used)
106	A03	A03	O	-	-	-	-	Ext. memory address 3 (16 bit bus select : not used)
107	A04	A04	O	-	-	-	-	Ext. memory address 4 (16 bit bus select : not used)
108	A05	A05	O	-	-	-	-	Ext. memory address 5 (16 bit bus select : not used)
109	A06	A06	O	-	-	-	-	Ext. memory address 6 (16 bit bus select : not used)
110	A07	A07	O	-	-	-	-	Ext. memory address 7 (16 bit bus select : not used)
111	A08	A08	O	-	-	-	-	Ext. memory address 8 (16 bit bus select : not used)
112	PD6	DSPF1	O	-	-	L	-	Flag 1 for DSP (RESERVE)
113	PD7,TM7IO	DISCPB_	I	-	iPu	-	-	Disc for scratch pulse B reverse phase count input
114	A09	A09	O	-	-	-	-	Ext. memory address 9 (16 bit bus select : not used)
115	A10	A10	O	-	-	-	-	Ext. memory address 10 (16 bit bus select : not used)
116	A11	A11	O	-	-	-	-	Ext. memory address 11 (16 bit bus select : not used)
117	A12	A12	O	-	-	-	-	Ext. memory address 12 (16 bit bus select : not used)
118	A13	A13	O	-	-	-	-	Ext. memory address 13 (16 bit bus select : not used)
119	VDD	VDD	-	-	-	-	-	Power (+3.3V)
120	PC4	DSPF2	O	-	-	L	-	Flag 1 for DSP (RESERVE)
121	A14	A14	O	-	-	-	-	Ext. memory address 14 (16 bit bus select : not used)
122	A15	A15	O	-	-	-	-	Ext. memory address 15 (16 bit bus select : not used)
123	A16	A16	O	-	-	-	-	Ext. memory address 16 (16 bit bus select : not used)
124	A17	A17	O	-	-	-	-	Ext. memory address 17 (16 bit bus select : not used)
125	A18	A18	O	-	-	-	-	Ext. memory address 18 (16 bit bus select : not used)
126	A19	A19	O	-	Pd	-	-	Ext. memory address 19 (16 bit bus select : not used)
127	A20	A20	O	-	-	-	-	Ext. memory address 20 (16 bit bus select : not used)
128	A21	A21	O	-	-	-	-	Ext. memory address 21 (16 bit bus select : not used)

## ADSP-BF531 (IC401)

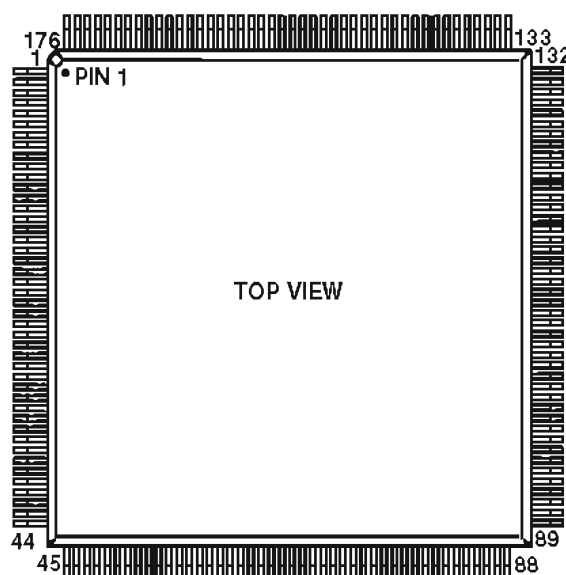

## ADSP-BF531 Terminal Function

Pin No.	Pin Name	Symbol	I/O	DET	Ext	Ini	Res	Function
1	GND	GND	-	-	-	-	-	GND
2	GND	GND	-	-	-	-	-	GND
3	GND	GND	-	-	-	-	-	GND
4	VROUT2		O	-	-	-	-	Ext. FET drive output 2
5	VROUT1	VROUT1	O	-	-	-	-	Ext. FET drive output 1
6	VDDEXT	VDDEXT	I	-	-	-	-	I/O power supply (+3.3V)
7	GND	GND	-	-	-	-	-	GND
8	GND	GND	-	-	-	-	-	GND
9	GND	GND	-	-	-	-	-	GND
10	CLKIN	CLKIN	I	-	-	-	-	Clock input
11	XTAL	XTAL	O	-	-	-	-	Crystal/Oscillation terminal
12	VDDEXT	VDDEXT	I	-	-	-	-	I/O power supply (+3.3V)
13	_RESET	_RESET	I	-	-	-	-	Reset signal input
14	NMI	NMI	I	-	-	-	-	Non-maskable interrupt
15	GND	GND	-	-	-	-	-	GND
16	RTXO		O	-	-	-	-	RTC crystal/Oscillation output
17	RTXI		I	-	-	L	L	RTC crystal/Oscillation input
18	VDDRRTC	VDDRRTC	I	-	-	-	-	Real time clock power supply (+3.3V)
19	GND	GND	-	-	-	-	-	GND
20	VDDEXT	VDDEXT	I	-	-	-	-	I/O power supply (+3.3V)
21	PPI_CLK		I	-	-	L	L	PPI clock
22	PPI0		O	-	-	L	-	PPI data 0
23	PPI1		O	-	-	L	-	PPI data 1
24	PPI2		O	-	-	L	-	PPI data 2
25	VDDINT	VDDINT	I	-	-	-	-	Core power supply (+1.2V)
26	PPI3		O	-	-	L	-	PPI data 3
27	PF15		O	-	-	L	-	Programmable flag 15
28	PF14		O	-	-	L	-	Programmable flag 14
29	PF13		O	-	-	L	-	Programmable flag 13
30	GND	GND	-	-	-	-	-	GND
31	VDDEXT	VDDEXT	I	-	-	-	-	I/O power supply (+3.3V)
32	PF12		O	-	-	L	-	Programmable flag 12
33	PF11		O	-	-	L	-	Programmable flag 11
34	PF10		O	-	-	L	-	Programmable flag 10
35	PF9		O	-	-	L	-	Programmable flag 9
36	PF8		O	-	-	L	-	Programmable flag 8
37	PF7		O	-	-	L	-	Programmable flag 7
38	PF6	DTIMES	O	-	-	L	-	Playback for SAMPLER clock output
39	GND	GND	-	-	-	-	-	GND

Pin No.	Pin Name	Symbol	I/O	DET	Ext	Ini	Res	Function
40	GND	GND	-	-	-	-	-	GND
41	GND	GND	-	-	-	-	-	GND
42	GND	GND	-	-	-	-	-	GND
43	GND	GND	-	-	-	-	-	GND
44	GND	GND	-	-	-	-	-	GND
45	VDDEXT	VDDEXT	I	-	-	-	-	I/O power supply (+3.3V)
46	PF5	DSPF3	O	-	-	L	-	Programmable flag 5, Flag 3 to $\mu$ com (RESERVE)
47	PF4	DSPF2	O	-	-	L	-	Programmable flag 4, Flag 2 to $\mu$ com (RESERVE)
48	PF3	DSPF1	O	-	-	L	-	Programmable flag 3, Flag 1 to $\mu$ com (RESERVE)
49	PF2	DSPF0	O	-	-	L	-	Programmable flag 2, Flag 0 to $\mu$ com (RESERVE)
50	PF1	DTIME	O	-	-	L	-	Programmable flag 1, Clock for playback output
51	PF0	BTEND	O	-	Pd	L	L	Programmable flag 0, All end : H
52	VDDINT	VDDINT	I	-	-	-	-	Core power supply (+1.2V)
53	SCK		O	-	-	L	-	Master slave clock
54	MISO		O	-	-	L	-	Master in slave out
55	MOSI		O	-	-	L	-	Master out slave in
56	GND	GND	-	-	-	-	-	GND
57	VDDEXT	VDDEXT	I	-	-	-	-	I/O power supply (+3.3V)
58	DT1SEC		O	-	-	L	-	Playback data send 1
59	DT1PRI	DDATA	I	-	-	-	-	Digital out data send 0 (serial port OUT 1)
60	TFS1	DLRCK	I	-	IPu	-	H	Digital out send frame sync (LRCK) signal (serial port OUT 1)
61	TSCLK1	DBCK	I	-	-	-	-	Digital out send frame sync (BCK) signal (serial port OUT 1)
62	DR1SEC		I	-	-	L	L	Playback data receive 1
63	DR1PRI		I	-	-	L	L	Playback data receive 0
64	RFS1		O	-	-	L	-	Receive frame sync (LRCK) signal (serial port IN 1)
65	RSCLK1		O	-	-	L	-	Receive frame sync (BCK) signal (serial port IN 1)
66	VDDINT	VDDINT	I	-	-	-	-	Core power supply (+1.2V)
67	DT0SEC		O	-	-	L	-	Playback data send 1
68	DT0PRI	ADATA	I	-	-	-	-	Analog playback data send 0 (serial port OUT 0)
69	TFS0	ALRCK	I	-	IPu	-	H	Analog playback send frame sync (LRCK) signal (serial port OUT 0)
70	GND	GND	-	-	-	-	-	GND
71	VDDEXT	VDDEXT	I	-	-	-	-	I/O power supply (+3.3V)
72	TSCLK0	ABCK	I	-	-	-	-	Analog playback send frame sync (BCK) signal (serial port OUT 0)
73	DR0SEC		I	-	-	L	L	Playback data receive 1
74	DR0PRI	SRDATA	I	-	-	-	-	Playback data receive 0 (serial port IN 0)
75	RFS0	LRCK	O	-	-	-	-	Receive frame sync (LRCK) signal (serial port IN 0)
76	RSCLK0	BCLK	I	-	IPu	-	H	Receive frame sync (BCK) signal (serial port IN 0)
77	TMR2		O	-	-	L	-	Timer 2
78	TMR1		O	-	-	L	-	Timer 1
79	TMR0		O	-	-	L	-	Timer 0
80	VDDINT	VDDINT	I	-	-	-	-	Core power supply (+1.2V)
81	TX	TX	O	-	-	H	-	UART send
82	RX	RX	I	-	Pu	-	H	UART receive
83	_EMU	_EMU	O	-	-	-	-	Emulation status
84	_TRST	_TRST	I	-	Pd	-	L	Test reset (JTAG)
85	TMS	TMS	I	-	Pu	-	H	Test mode select (JTAG)
86	TDI	TDI	I	-	Pu	-	H	Test data input (JTAG)
87	TD0	TD0	O	-	-	-	-	Test data output (JTAG)
88	GND	GND	-	-	-	-	-	GND
89	GND	GND	-	-	-	-	-	GND
90	GND	GND	-	-	-	-	-	GND
91	GND	GND	-	-	-	-	-	GND
92	GND	GND	-	-	-	-	-	GND
93	VDDEXT	VDDEXT	I	-	-	-	-	I/O power supply (+3.3V)
94	TCK	TCK	I	-	Pu	-	H	Test clock (JTAG)



Pin No.	Pin Name	Symbol	I/O	DET	Ext	Ini	Res	Function
95	BMODE1	BMODE1	I	-	-	-	-	Boot mode strap 1
96	BMODE0	BMODE0	I	-	-	-	-	Boot mode strap 0
97	GND	GND	-	-	-	-	-	GND
98	DATA15	D15	I/O	-	-	-	-	Ext. bus data 15
99	DATA14	D14	I/O	-	-	-	-	Ext. bus data 14
100	DATA13	D13	I/O	-	-	-	-	Ext. bus data 13
101	DATA12	D12	I/O	-	-	-	-	Ext. bus data 12
102	DATA11	D11	I/O	-	-	-	-	Ext. bus data 11
103	DATA10	D10	I/O	-	-	-	-	Ext. bus data 10
104	DATA9	D9	I/O	-	-	-	-	Ext. bus data 9
105	DATA8	D8	I/O	-	-	-	-	Ext. bus data 8
106	GND	GND	-	-	-	-	-	GND
107	VDDEXT	VDDEXT	I	-	-	-	-	I/O power supply (+3.3V)
108	DATA7	D7	I/O	-	-	-	-	Ext. bus data 7
109	DATA6	D6	I/O	-	-	-	-	Ext. bus data 6
110	DATA5	D5	I/O	-	-	-	-	Ext. bus data 5
111	VDDINT	VDDINT	I	-	-	-	-	Core power supply (+1.2V)
112	DATA4	D4	I/O	-	-	-	-	Ext. bus data 4
113	DATA3	D3	I/O	-	-	-	-	Ext. bus data 3
114	DATA2	D2	I/O	-	-	-	-	Ext. bus data 2
115	DATA1	D1	I/O	-	-	-	-	Ext. bus data 1
116	DATA0	D0	I/O	-	-	-	-	Ext. bus data 0
117	GND	GND	-	-	-	-	-	GND
118	VDDEXT	VDDEXT	I	-	-	-	-	I/O power supply (+3.3V)
119	_BG		O	-	-	-	-	Bus grant signal
120	_BGH		O	-	-	-	-	Bus grant hang signal
121	ADDR19	BA1	I/O	-	-	-	-	Ext. bus address 19
122	ADDR18	BA0/ADDR18	I/O	-	-	-	-	Ext. bus address 18
123	ADDR17	ADDR17	I/O	-	-	-	-	Ext. bus address 17
124	ADDR16	ADDR16	I/O	-	-	-	-	Ext. bus address 16
125	ADDR15	ADDR15	I/O	-	-	-	-	Ext. bus address 15
126	ADDR14	ADDR14	I/O	-	-	-	-	Ext. bus address 14
127	ADDR13	ADDR13	I/O	-	-	-	-	Ext. bus address 13
128	GND	GND	-	-	-	-	-	GND
129	GND	GND	-	-	-	-	-	GND
130	GND	GND	-	-	-	-	-	GND
131	GND	GND	-	-	-	-	-	GND
132	GND	GND	-	-	-	-	-	GND
133	GND	GND	-	-	-	-	-	GND
134	VDDEXT	VDDEXT	I	-	-	-	-	I/O power supply (+3.3V)
135	ADDR12	ADDR12	I/O	-	-	-	-	Ext. bus address 12
136	ADDR11	ADDR11	I/O	-	-	-	-	Ext. bus address 11
137	ADDR10	ADDR10	I/O	-	-	-	-	Ext. bus address 10 (SDRAM: connects SDA10)
138	ADDR9	ADDR9	I/O	-	-	-	-	Ext. bus address 9
139	ADDR8	ADDR8	I/O	-	-	-	-	Ext. bus address 8
140	ADDR7	ADDR7	I/O	-	-	-	-	Ext. bus address 7
141	ADDR6	ADDR6	I/O	-	-	-	-	Ext. bus address 6
142	ADDR5	ADDR5	I/O	-	-	-	-	Ext. bus address 5
143	VDDINT	VDDINT	I	-	-	-	-	Core power supply (+1.2V)
144	GND	GND	-	-	-	-	-	GND
145	VDDEXT	VDDEXT	I	-	-	-	-	I/O power supply (+3.3V)
146	ADDR4	ADDR4	I/O	-	-	-	-	Ext. bus address 4
147	ADDR3	ADDR3	I/O	-	-	-	-	Ext. bus address 3
148	ADDR2	ADDR2	I/O	-	-	-	-	Ext. bus address 2
149	ADDR1	ADDR1	I/O	-	-	-	-	Ext. bus address 1

Pin No.	Pin Name	Symbol	I/O	DET	Ext	Ini	Res	Function
150	_ABE1	SDQM1	I/O	-	-	-	-	SDRAM data mask 1
151	_ABE0	SDQM0	I/O	-	-	-	-	SDRAM data mask 0
152	_AWE		O	-	-	H	H	Async memory write enable
153	_ARE	_ARE	O	-	-	H	H	Async memory read enable
154	_AOE		O	-	-	-	-	Async memory output enable
155	GND	GND	-	-	-	-	-	GND
156	VDDEXT	VDDEXT	I	-	-	-	-	I/O power supply (+3.3V)
157	VDDINT	VDDINT	I	-	-	-	-	Core power supply (+1.2V)
158	_AMS3		O	-	-	-	-	Async memory bank select 3
159	_AMS2		O	-	-	-	-	Async memory bank select 2
160	_AMS1		O	-	-	-	-	Async memory bank select 1
161	_AMS0	_AMS0	O	-	-	-	-	Async memory bank select 0
162	ARDY		I	-	-	-	L	Bus wait ready signal
163	_BR		I	-	-	-	H	Bus request signal
164	SA10	SA10	I/O	-	-	-	-	Sync memory A10
165	_SWE	_SWE	O	-	-	-	-	Sync memory write enable signal
166	_SCAS	_SCAS	O	-	-	-	-	Sync memory row address strobe signal
167	_SRAS	_SRAS	O	-	-	-	-	Sync memory column address strobe signal
168	VDDINT	VDDINT	I	-	-	-	-	Core power supply (+1.2V)
169	CLKOUT	CLKOUT	I/O	-	-	-	-	Sync memory clock output
170	GND	GND	-	-	-	-	-	GND
171	VDDEXT	VDDEXT	I	-	-	-	-	I/O power supply (+3.3V)
172	_SMS	_SMS	O	-	-	-	-	Sync memory bank select signal
173	SCKE	SCKE	O	-	-	-	-	Sync memory clock enable signal
174	GND	GND	-	-	-	-	-	GND
175	GND	GND	-	-	-	-	-	GND
176	GND	GND	-	-	-	-	-	GND

DN-S1000

MN6627933 (IC201)

**MN6627933CG**

Pinout details:

- Top edge (75-51): STAT \*, MLD, MDATA, MCLK, EXT2 \*, EXT1 \*, EXT0 \*, DVSS2, DVDD3, TMON2, NC, NC, TMON1, NC, LOVDD1, LOOUTR, LOYSS1, LOOUTL, AVSS, PLLFO, PLLF, PWMSEL, DSLF, ARF, IREF
- Bottom edge (1-25): D11, D10, D9, D8, UDQM, SDRCK, A11, A9, A8, A7, A6, A5, A4, LDQM, NWE, NCAS, NRAS, NCS, A3, A2, A1, A0, DRVDD, DVSS1, A10
- Left edge (76-100): BLKCK \*, SMCK \*, PMCK \*, TX \*, FLAG \*, NRST, NTEST, DVSS3, X1, X2, IOVDD2, DVDD2, D2, D1, D0, D3, D4, D5, D6, D7, D15, D14, DRVDD2, D13, D12
- Right edge (50-26): AVDD, BDO, OFT, NRFDET, LDON, RFENV, ADPVCC, TE, FE, FBAL, TBAL, IOVDD1, FOM \*, FOP, TRM \*, TRP, TRVM2 \*, TRVP2 \*, TRVM \*, TRVP, SPPOL \*, SPOUT, DVDD1, BA0 \*, BA1 \*

**MN6627933 Terminal Function**

Pin No.	Pin Name	I/O	Function
1	D11	I/O	SDRAM data signal I/O 11
2	D10	I/O	SDRAM data signal I/O 10
3	D9	I/O	SDRAM data signal I/O 9
4	D8	I/O	SDRAM data signal I/O 8
5	UDQM	O	SDRAM higher rank byte data mask signal output
6	SDRCK	O	SDRAM clock signal output
7	A11	O	SDRAM address signal output 11
8	A9	O	SDRAM address signal output 9
9	A8	O	SDRAM address signal output 8
10	A7	O	SDRAM address signal output 7
11	A6	O	SDRAM address signal output 6
12	A5	O	SDRAM address signal output 5
13	A4	O	SDRAM address signal output 4
14	LDQM	O	SDRAM lower rank byte data mask signal output
15	NWE	O	SDRAM write enable signal output
16	NCAS	O	SDRAM CAS control signal output
17	NRAS	O	SDRAM RAS control signal output

19

Pin No.	Pin Name	I/O	Function
18	NCS	O	SDRAM chip select signal output
19	A3	O	SDRAM address signal output 3
20	A2	O	SDRAM address signal output 2
21	A1	O	SDRAM address signal output 1
22	A0	O	SDRAM address signal output 0
23	DRVDD1	I	Power supply 1 for SDRAM interface I/O
24	DVSS1	I	GND 1 for digital circuits
25	A10	O	SDRAM address signal output 10
26	*BA1	O	SDRAM bank selection signal output 1
27	*BA0	O	SDRAM bank selection signal output 0
28	DVDD1	I	Power supply 1 for inside digital circuits
29	SPOUT	O	Spindle drive signal output (absolute value)
30	*SPPOL	O	Spindle drive signal output (polarity)
31	TRVP	O	Traverse drive signal output (positive polarity)
32	*TRVM	O	Traverse drive signal output (negative polarity)
33	*TRVP2	O	Traverse drive signal output 2 (positive polarity)
34	*TRVM2	O	Traverse drive signal output 2 (negative polarity)
35	TRP	O	Tracking drive signal output (positive polarity)
36	*TRM	O	Tracking drive signal output (negative polarity)
37	FOP	O	Focus drive signal output (positive polarity)
38	*FOM	O	Focus drive signal output (negative polarity)
39	IOVDD1	I	Power supply 1 for digital I/O
40	TBAL	O	Tracking balance adjustment signal output
41	FBAL	O	Focus balance adjustment signal output
42	FE	I	Focus error signal input
43	TE	I	Tracking error signal input
44	ADPVCC	I	Voltage input for supply voltage monitor
45	RFENV	I	RF envelope signal input
46	LDON	O	Laser ON signal output
47	NRFDET	I	RF detect signal input
48	OFT	I	Off-track signal input
49	BDO	I	Dropout signal input
50	AVDD	I	Power supply 1 for analog circuits
51	IREF	I	Analog reference current input
52	ARF	I	RF signal input
53	DSLIF	O	DSL loop filter
54	PWMSEL	I	PWM output mode selection input L: Direct H: 3-state
55	PLLIF	O	PLL loop filter (phase comparison output)
56	PLLFO	O	PLL loop filter (speed comparison output)
57	AVSS	I	GND 1 for analog circuits
58	LOOUTL	O	L-ch audio signal output for lineout output
59	LOVSS1	I	GND for lineout output
60	LOOUTR	O	R-ch audio signal output for lineout output
61	LOVDD1	I	Power supply for lineout output
62	N.C.	-	
63	TMON1	O	Test monitor output 1
64	N.C.	-	
65	N.C.	-	
66	TMON2	O	Test monitor output 2
67	DVDD3	I	Power supply 3 for digital circuits
68	DVSS2	I	GND 2 for digital circuits
69	*EXT0	I/O	Expansion I/O port 0
70	*EXT1	I/O	Expansion I/O port 1
71	*EXT2	I/O	Expansion I/O port 2
72	MCLK	I	µcom command clock signal input

Pin No.	Pin Name	I/O	Function
73	MDATA	I	μcom command data signal input
74	MLD	I	μcom command load signal input
75	*STAT	O	Status signal output
76	*BLKCK	O	Subcode block clock signal output
77	*SMCK	O	4.2336MHz/8.4672MHz clock signal output
78	*PMCK	O	88.2kHz clock signal output
79	*TX	O	Digital audio interface signal output
80	*FLAG	O	Flag signal output
81	NRST	I	LSI reset signal input
82	NTEST	I	Test mode setup input
83	DVSS3	I	GND 3 for digital circuits
84	X1	I	Crystal oscillator circuit input
85	X2	O	Crystal oscillator circuit output
86	IOVDD2	I	Power supply 2 for digital I/O
87	DVDD2	I	Power supply 2 for inside digital circuits
88	D2	I/O	SDRAM data signal I/O 2
89	D1	I/O	SDRAM data signal I/O 1
90	D0	I/O	SDRAM data signal I/O 0
91	D3	I/O	SDRAM data signal I/O 3
92	D4	I/O	SDRAM data signal I/O 4
93	D5	I/O	SDRAM data signal I/O 5
94	D6	I/O	SDRAM data signal I/O 6
95	D7	I/O	SDRAM data signal I/O 7
96	D15	I/O	SDRAM data signal I/O 15
97	D14	I/O	SDRAM data signal I/O 14
98	DRVDD2	I	Power supply 2 for SDRAM interface I/O
99	D13	I/O	SDRAM data signal I/O 13
100	D12	I/O	SDRAM data signal I/O 12

Note) Pins marked with an asterisk can be switched to different signals by using microcontroller commands.

**M66005AFP (IC601)**

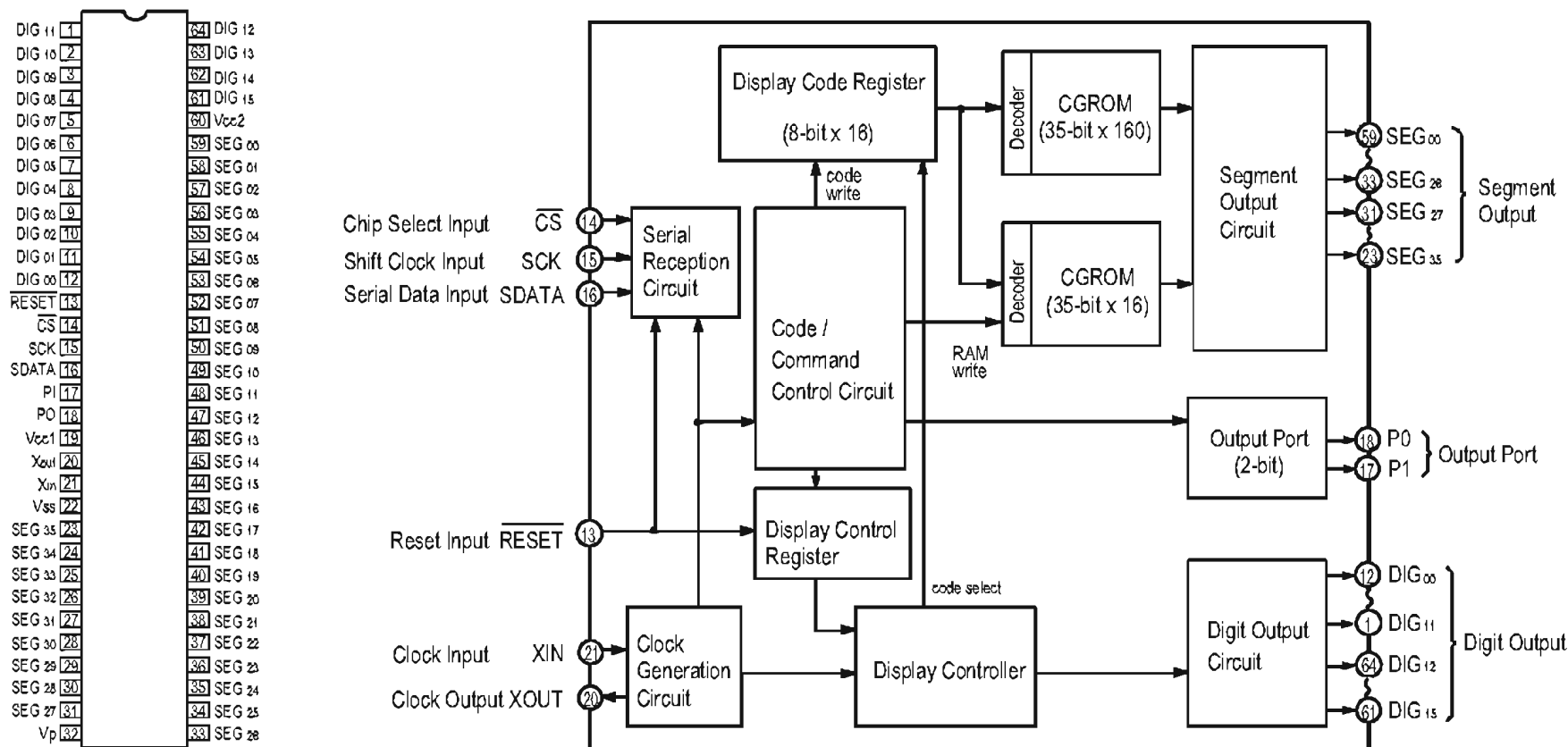

**M66005FP Terminal Function**

Symbol	Name	Function
RESET	Reset Input	Initializes internal state of M66005.
CS	Chip Select Input	Able to communicate with MCU in "L" mode. Command from MCU will be disregarded in "H" mode.
SCK	Shift Clock Input	Shifts input data at rise from "L" to "H".
SDATA	Serial Data Input	Inputs character code or command data needed to display from MSB.
XIN	Clock Input	Sets oscillation frequency by connecting external resistor and capacitor (maximum oscillation frequency fosc (max)=1MHz). Also feasible to apply external clock. In this case, inject external clock to Xin terminal and open Xout terminal.
XOUT	Clock Output	
DIG 00~DIG 15	Digit Output	Connect to digit terminal of VFD. DIG00~DIG15 correspond to the 1st figure to 16th figure respectively.
SEG 00~SEG 35	Segment Output	Connect to segment terminal of VFD. For corresponding SEG00~SEG35 to segment terminal of VFD, refer to the figure right.
P0, P1		Output port (static operation).
VCC1		Positive power supply terminal for internal logic.
VCC2		Positive power supply terminal for high tension output port.
VSS		GND terminal.
Vp		Negative power supply terminal for VFD drive.

(Forwarding connection of segment output terminal.)

□ in the right figure indicates 1 dot of segment, the figure in □ shows the segment output terminal number (00~35) to be connected.

00	01	02	03	04
05	06	07	08	09
10	11	12	13	14
15	16	17	18	19
20	21	22	23	24
25	26	27	28	29
30	31	32	33	34

35

AN8785SB (IC202)

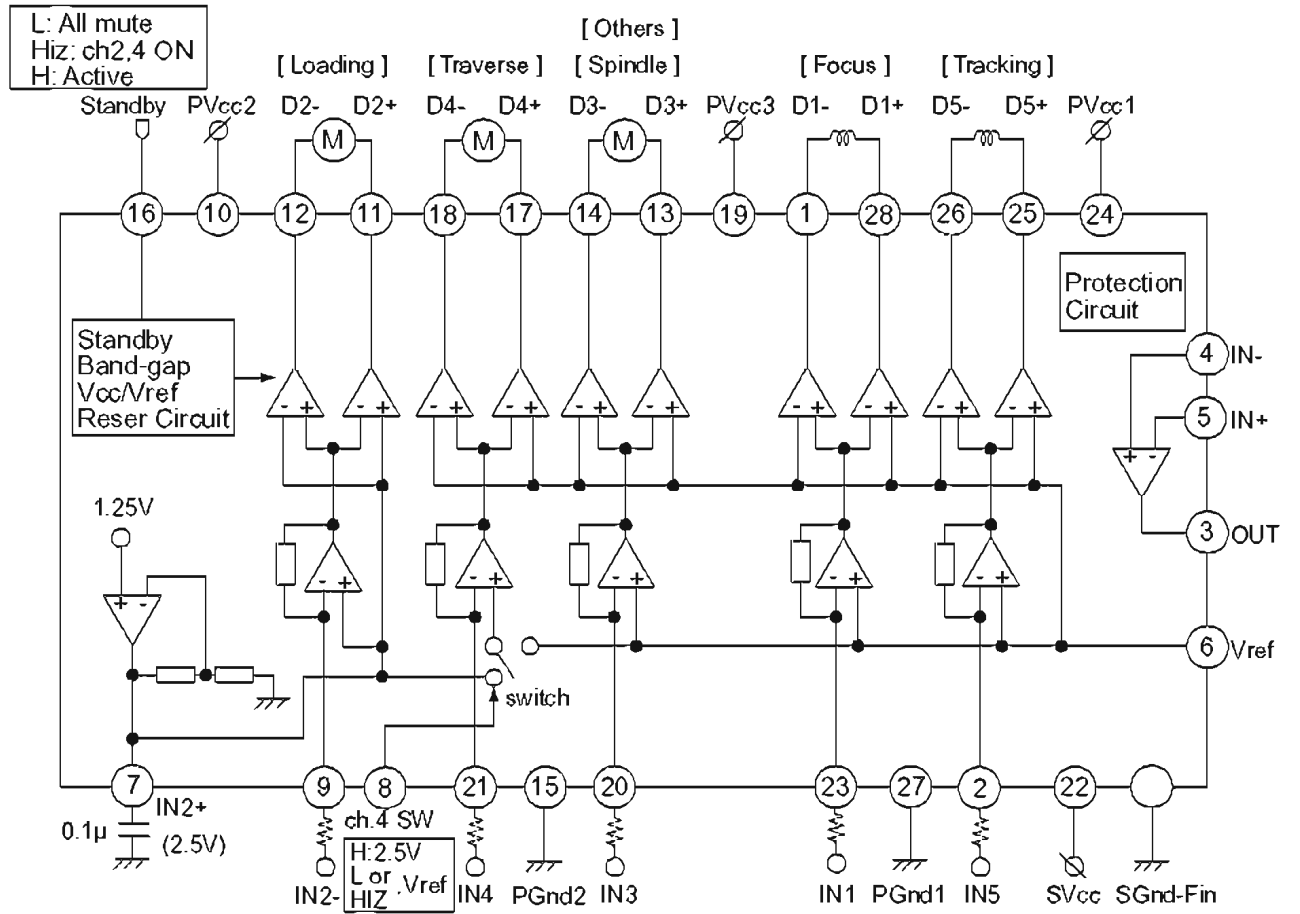
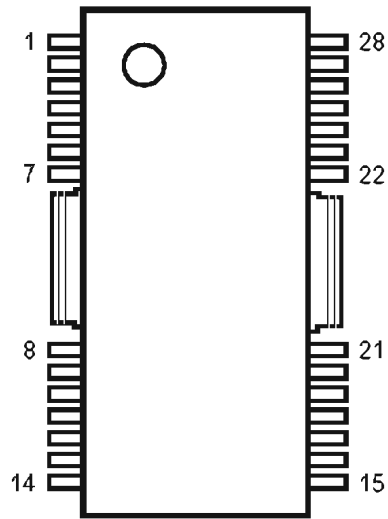

AN22002A (IC203)

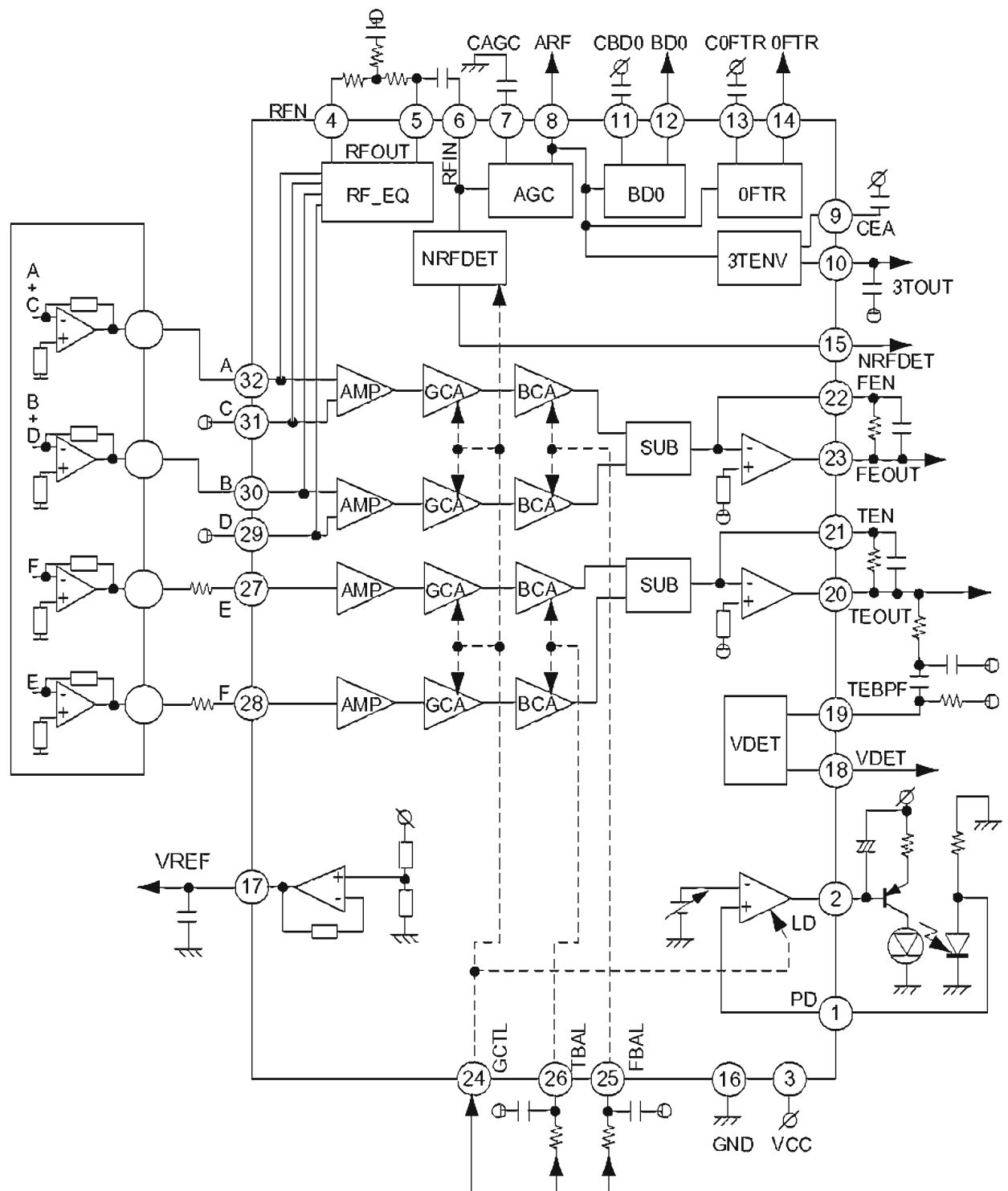
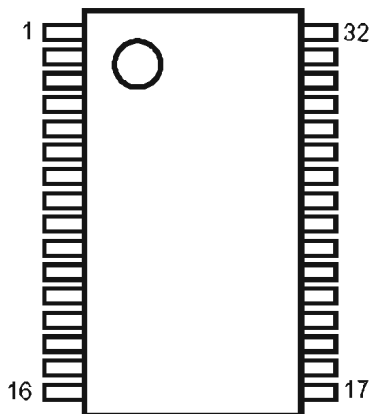

PCM1748 (IC106)

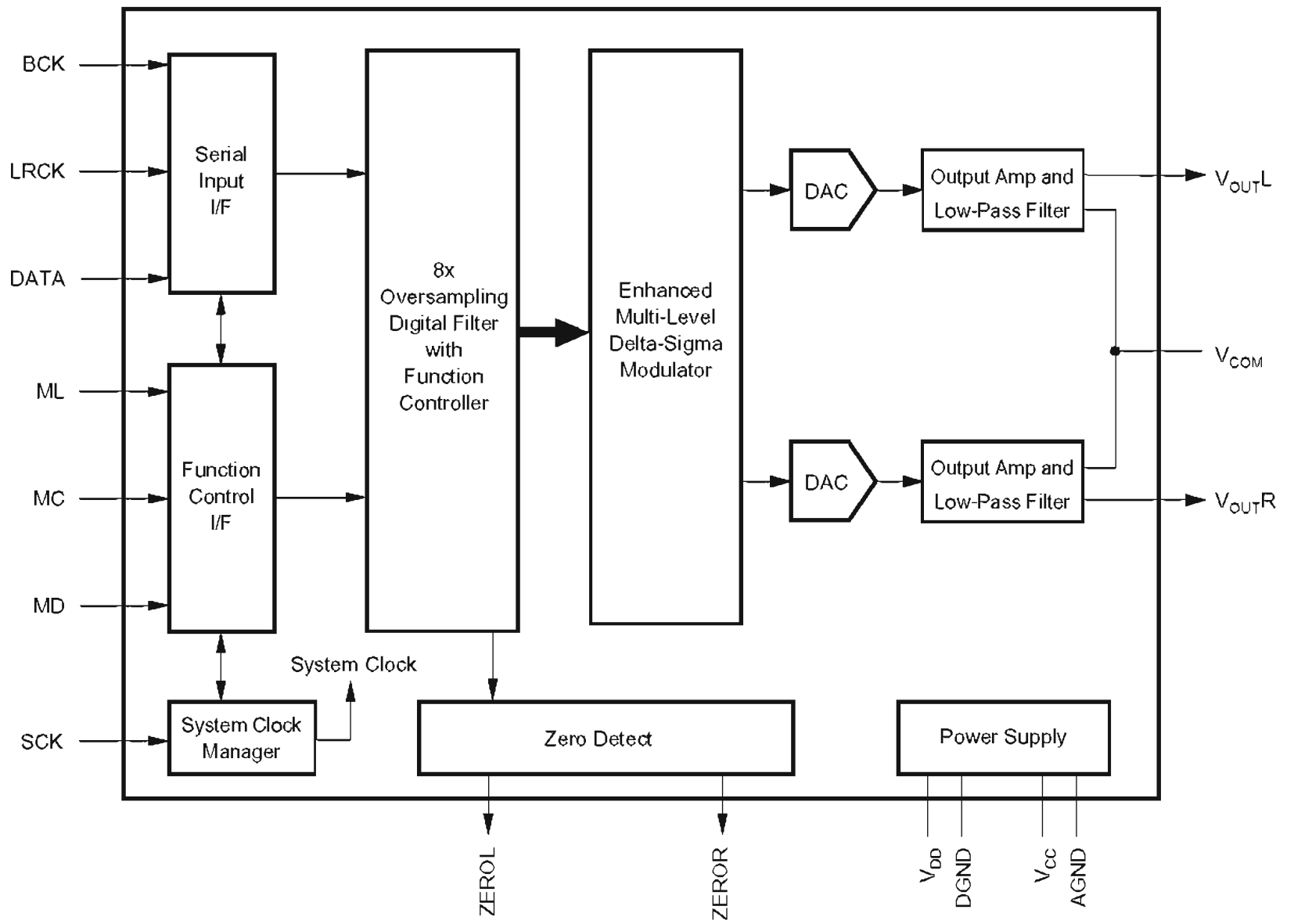
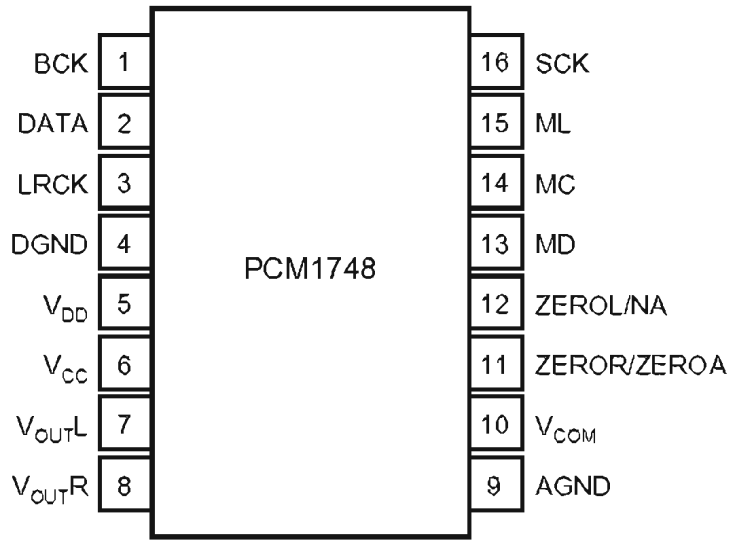



**64M SDRAM (IC210)  
128M SDRAM (IC402)**

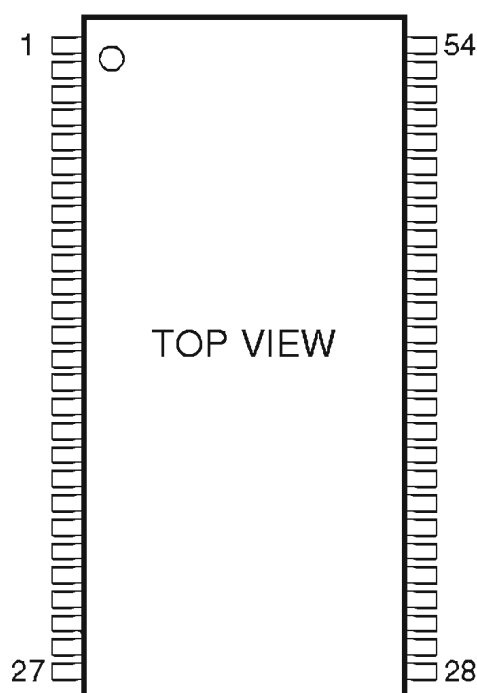

**Pin Assignment**

Pin No.	Pin Name	Function	Description
22, 23~26, 29~35	A0~A11	Address	Multiplexed pins for row and column address Row address A0~A11 Column address A0~A8
20, 21	BS0, BS1	Bank Select	Select bank to activate during row address latch time, or bank to read/write during address latch time
2, 4, 5, 7, 8, 10, 11, 13, 42, 44, 45, 47, 48, 50, 51, 53	DQ0~DQ15	Data Input/Output	Multiplexed pins for data output and input
19	CS#	Chip Select	Disable or enable the command decoder When command decoder is disabled, new command is ignored and previous operation continues
18	RAS#	Row Address Strobe	Command input When sampled at the rising edge of the clock, RAS#, CAS# and WE# define the operation to be executed.
17	CAS#	Column Address Strobe	Referred to RAS#
16	WE#	Write Enable	Referred to RAS#
15, 39	UDQM/LDQM	input/output mask	The output buffer is placed at Hi-Z (with latency of 2) when DQM is sampled high in read cycle. In write cycle, sampling DQM high will block the write operation with zero latency
38	CLK	Clock Inputs	System clock used to sample inputs on the rising edge of clock
37	CKE	Clock Enable	CKE controls the clock activation and deactivation When CKE is low, Power Down mode, Suspend mode, or Self Refresh mode is entered
1, 14, 27	Vcc	Power (+3.3V)	Power for input buffers and logic circuit inside DRAM
28, 41, 54	Vss	Ground	Ground for input buffers and logic circuit inside DRAM
3, 9, 43, 49	VccQ	Power (+3.3V) for I/O buffer	Separated power from Vcc, used for output buffers to improve noise
6, 12, 46, 52	VssQ	Ground for I/O buffer	Separated ground from Vss, used for output buffers to improve noise
36, 40	NC	No Connection	No Connection

**BU2090F (IC602)**

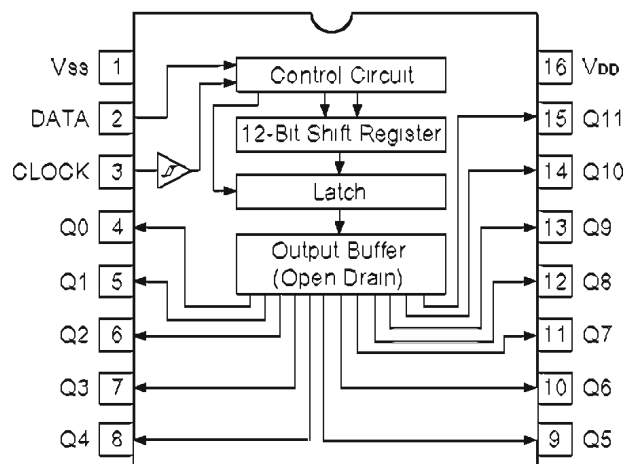

**TPC6103 (IC410)**

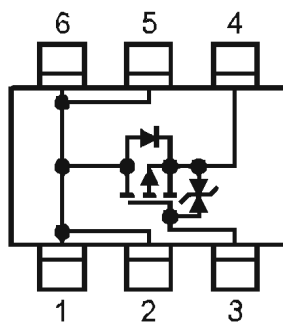

## 2. FL DISPLAY 13-MT-99GN (FL601)

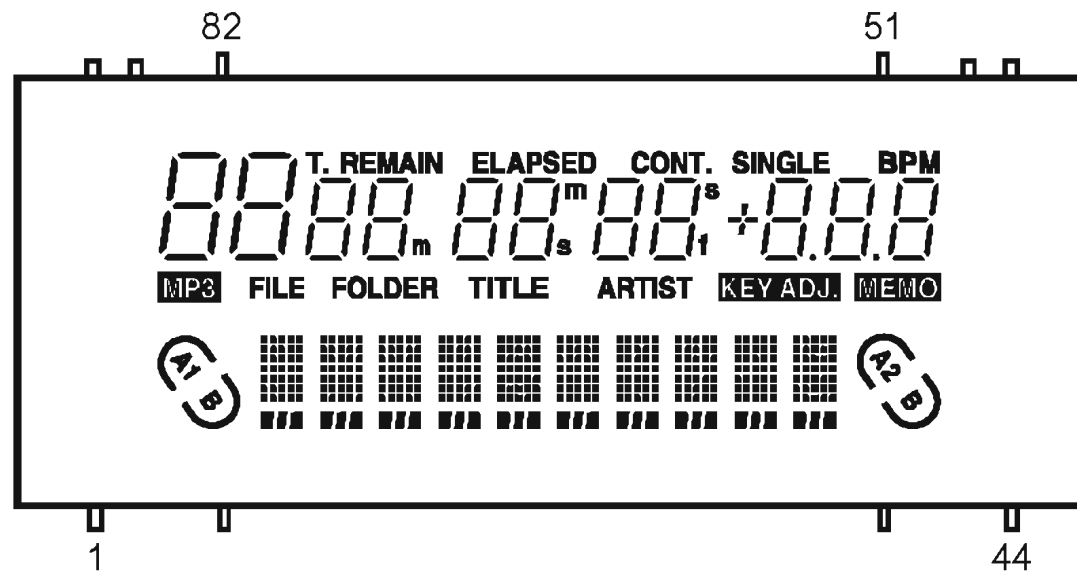

### Pin Connection

PIN NO.	8	8	8	8	8	8	8	8	7	7	7	7	7	7	7	7	7	7	6	6	6	6	6	6	6	6	6	5	5	5	5	5	5	5	5	5	4	4	4	4	4	
CONNECTION	N	N	N	N	N	N	3	2	1	0	9	8	7	6	5	4	3	2	1	N	N	N	N	N	N	3	3	3	3	3	3	2	2	2	2	2	N	N	N	N	N	N

PIN NO.	1	2	3	4	5	6	7	8	9	0	1	1	1	1	1	1	1	1	1	2	2	2	2	2	2	2	2	2	3	3	3	3	3	3	3	3	3	3	4	4	4	4	4
CONNECTION	F	F	F	F	N	N	I	N	N	N	N	3	3	P	P	P	P	P	P	P	1	1	1	1	1	1	1	1	1	2	2	2	2	2	N	N	N	F	F	F	F	F	

- NOTE
- 1) F1, F2 --- Filament
  - 2) NP ----- No pin
  - 3) NC ----- No connection  
(NC pin should be electrically open on the PC board)
  - 4) DL ----- Datum Line
  - 5) 1G~13G -- Grid
  - 6) IC ----- Internal connection  
(IC pin should be electrically open on the PC board)
  - 7) Field of vision is a minimum of 26° from the upper side,  
26° from the lower side.
  - 8) Solder composition is Sn-3Ag-0.5Cu.

### Grid Assignment

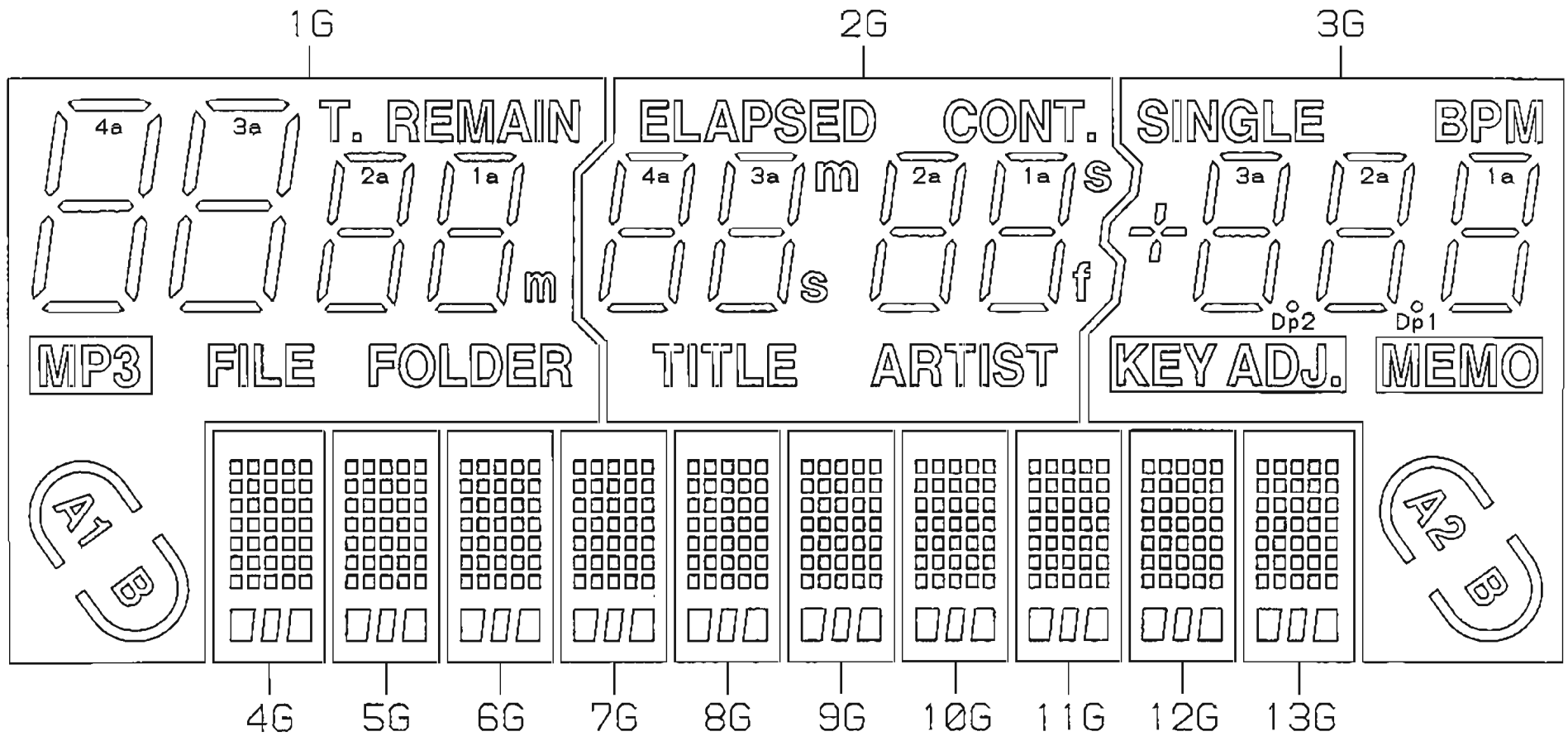

Segment Designation

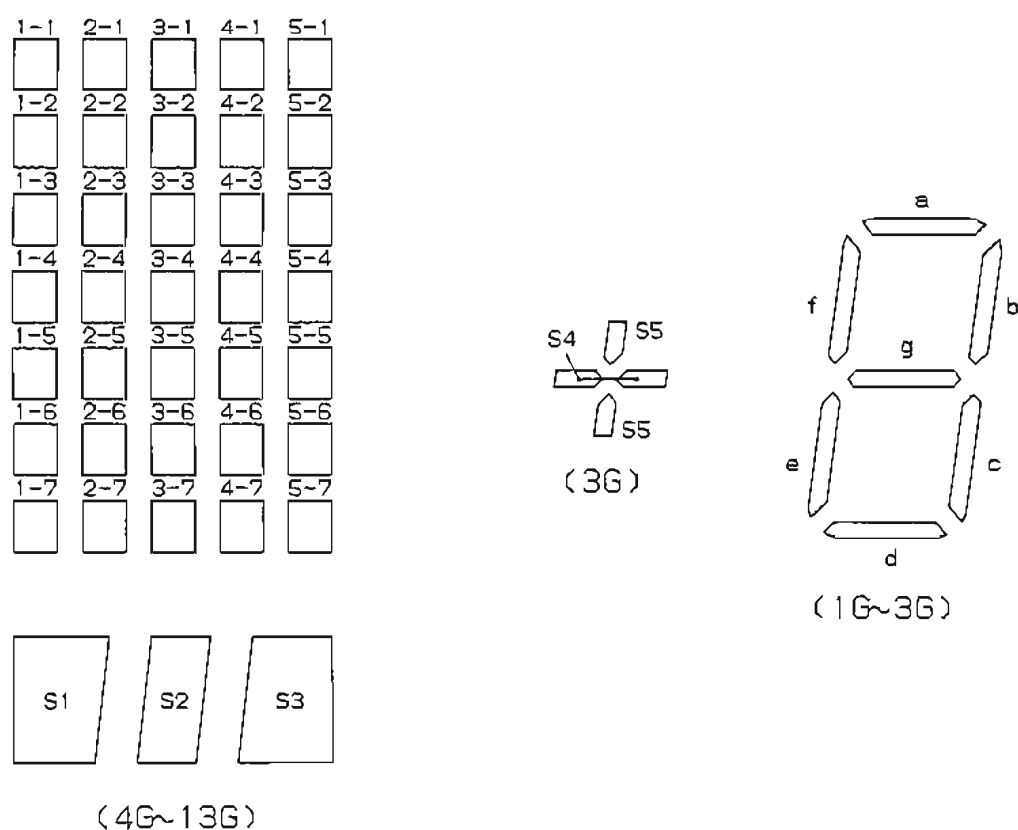

Anode Connection

	1G	2G	3G	4G~13G
P1	1d	1d		1-1
P2	1e	1e		2-1
P3	1c	1c		3-1
P4	1g	1g		4-1
P5	1f	1f	-	5-1
P6	1b	1b	-	1-2
P7	1a	1a	-	2-2
P8		f	-	3-2
P9	2d	2d	1d	4-2
P10	2e	2e	1e	5-2
P11	2c	2c	1c	1-3
P12	2g	2g	1g	2-3
P13	2f	2f	1f	3-3
P14	2b	2b	1b	4-3
P15	2a	2a	1a	5-3
P16	T.	S (RIGHT)	Dp1	1-4
P17	3d	3d	2d	2-4
P18	3e	3e	2e	3-4
P19	3c	3c	2c	4-4
P20	3g	3g	2g	5-4
P21	3f	3f	2f	1-5
P22	3b	3b	2b	2-5
P23	3a	3a	2a	3-5
P24		S (LEFT)	Dp2	4-5
P25	4d	4d	3d	5-5
P26	4e	4e	3e	1-6
P27	4c	4c	3c	2-6
P28	4g	4g	3g	3-6
P29	4f	4f	3f	4-6
P30	4b	4b	3b	5-6
P31	4a	4a	3a	1-7
P32			BPM	2-7
P33		CONT.	S4	3-7
P34		-	S5	4-7
P35		-	-	5-7
P36	REMAIN	ELAPSED	SINGLE	S1
P37	FOLDER	ARTIST	KEY ADJ.	S2
P38	FILE	TITLE	MEMO	S3

PRINTED WIRING BOARDS  
 GU-3607 MAIN P.W.B. UNIT

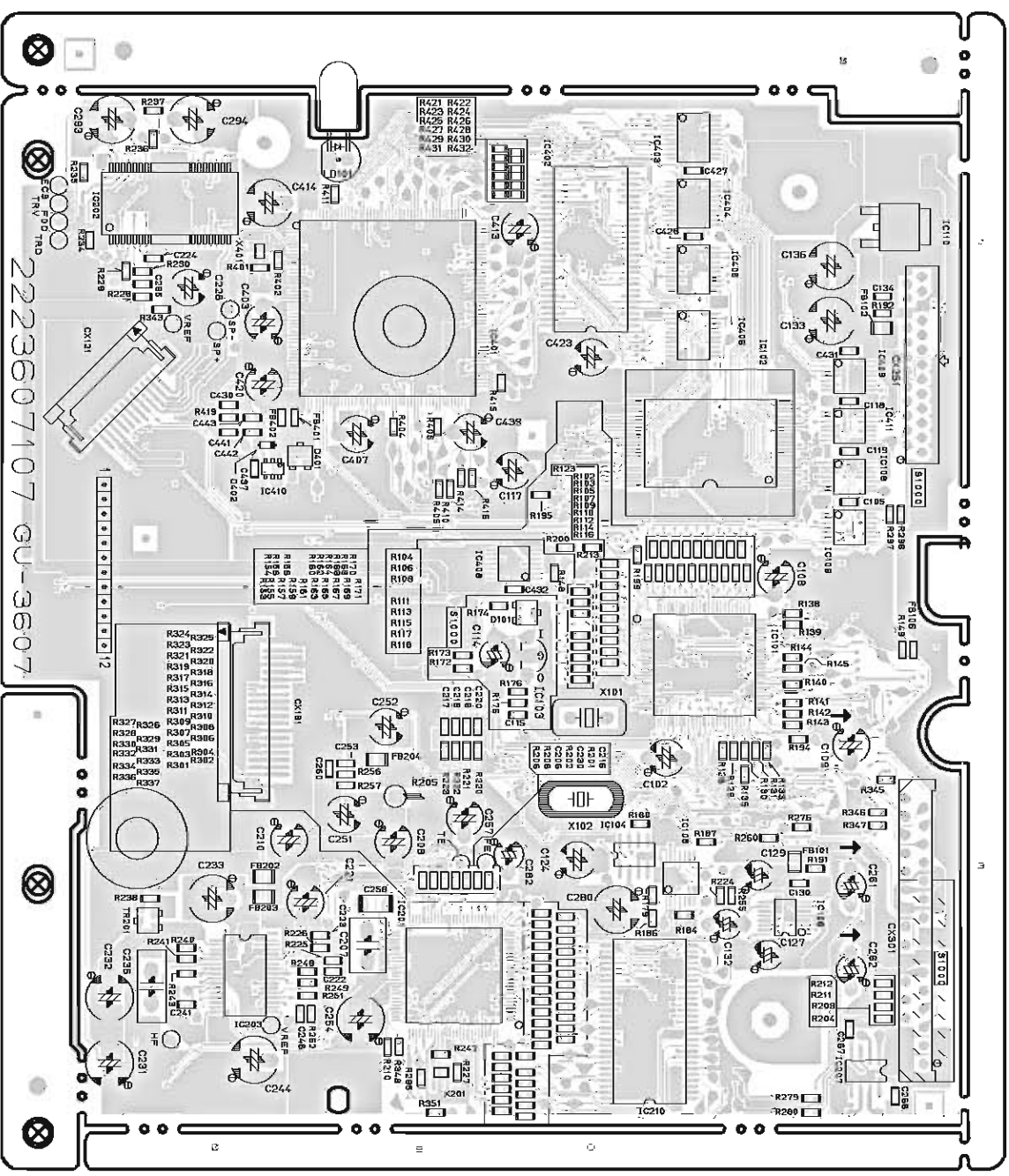

COMPONENT SIDE

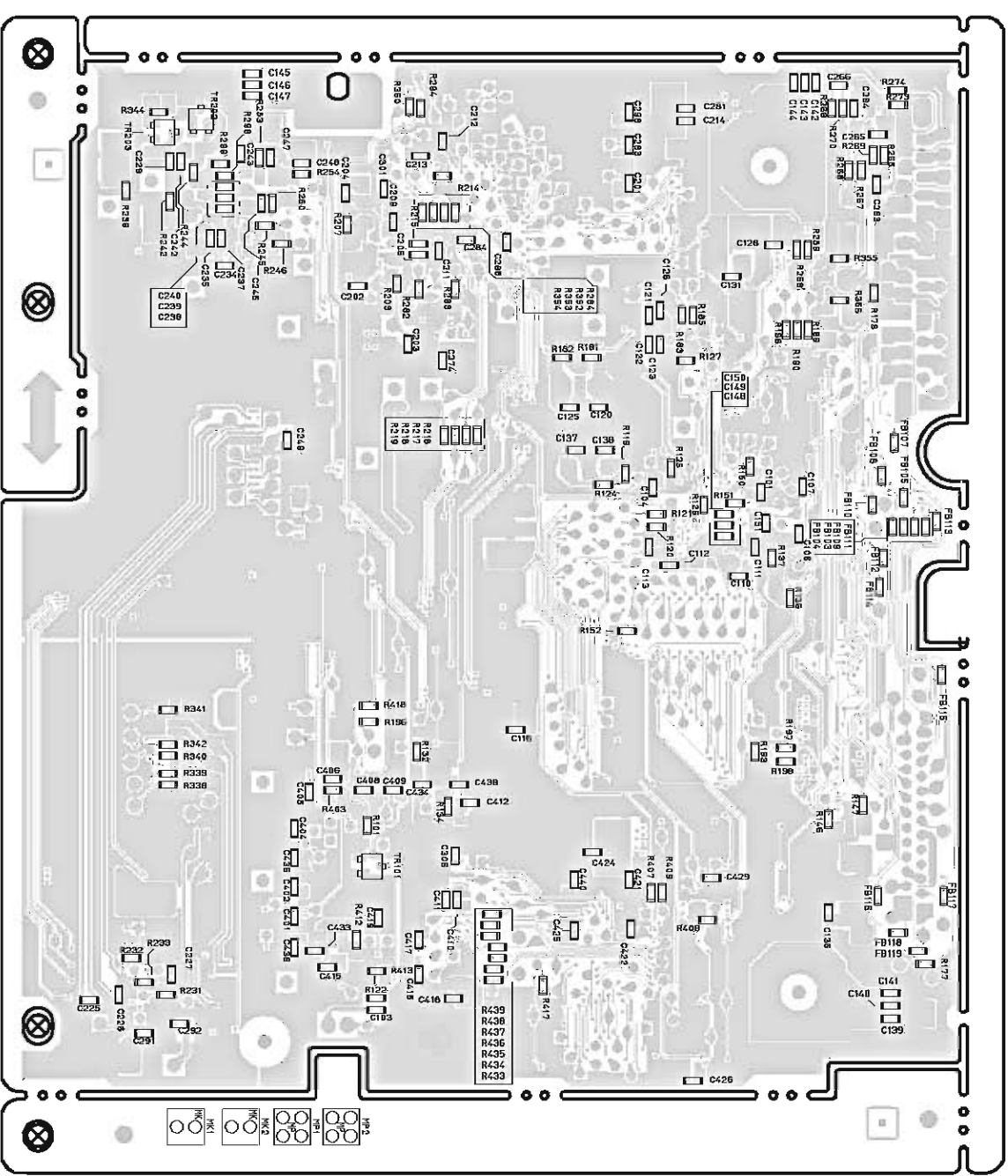

FOIL SIDE

GU-3608 PANEL P.W.B. UNIT

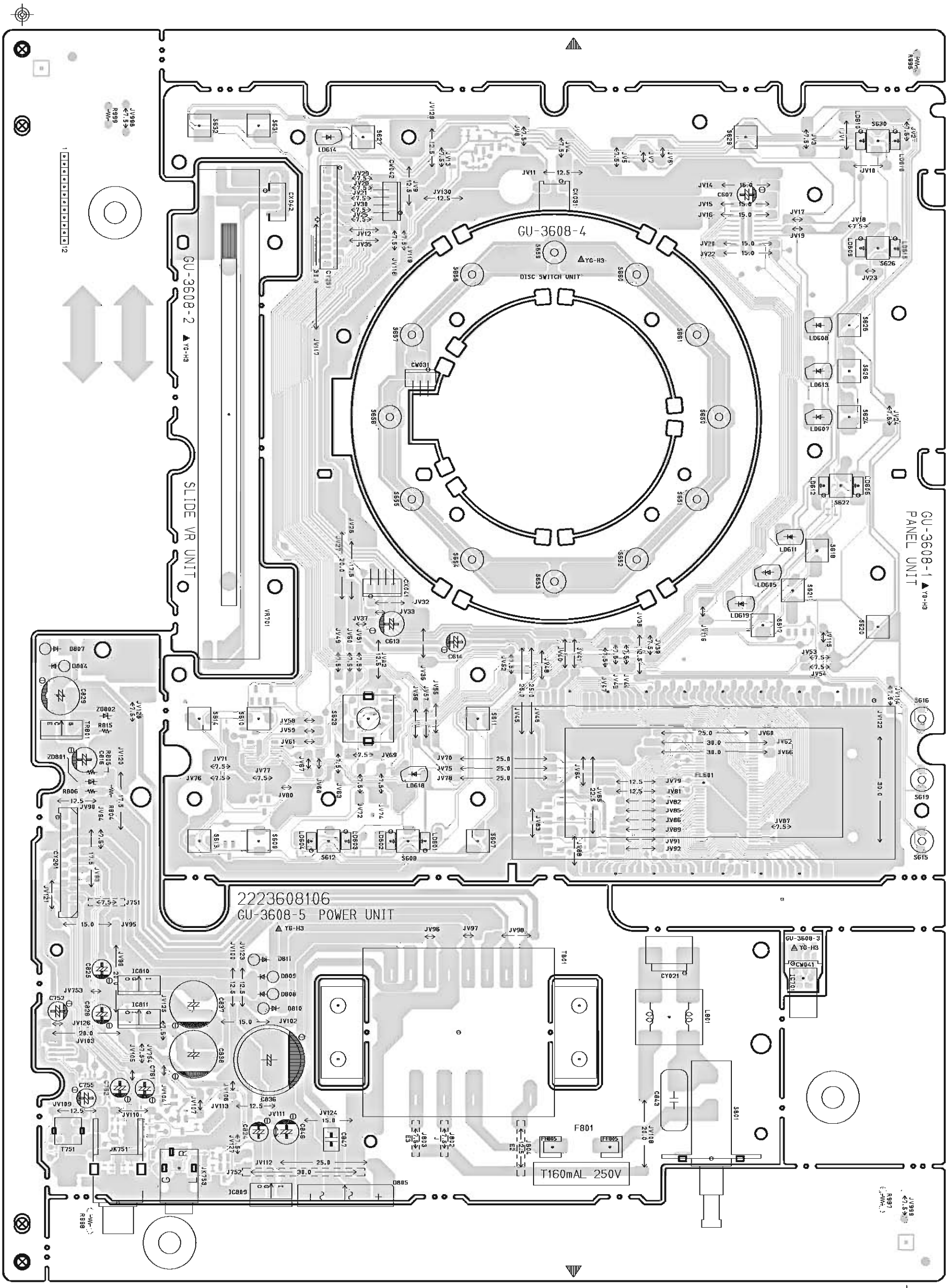

COMPONENT SIDE

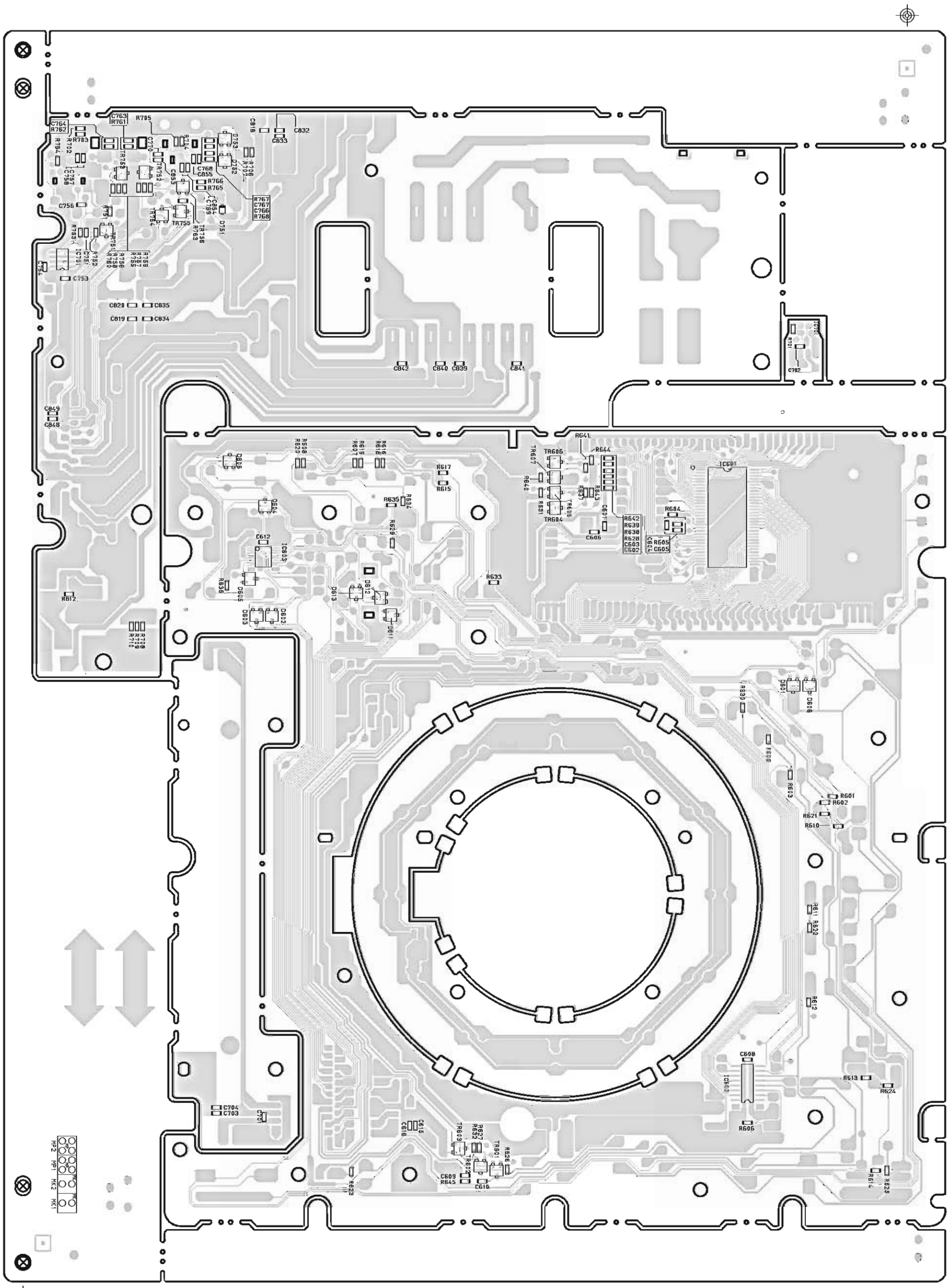

FOIL SIDE



## NOTE FOR PARTS LIST

- Part indicated with the mark "⊙" are not always in stock and possibly to take a long period of time for supplying, or in some case supplying of part may be refused.
- When ordering of part, clearly indicate "1" and "I" (i) to avoid mis-supplying.
- Ordering part without stating its part number can not be supplied.
- Part indicated with the mark "★" is not illustrated in the exploded view.
- Not including Carbon Film Resistor ±5%, 1/4W Type in the P.W.Board parts list. (Refer to the Schematic Diagram for those parts.)
- Not including Carbon Chip Resistor 1/16W Type in the P.W.Board parts list. (Refer to the Schematic Diagram for those parts.)

**WARNING:**

Parts marked with this symbol  have critical characteristics. Use ONLY replacement parts recommended by the manufacturer.

## 部品表について

1. ●印の部品は常時在庫していませんので供給に長時間を要することがあります。場合によっては、供給をお断りすることがあります。
2. 部品を発注する際は特に数字の“1”と英字の“I”との区別をはっきり記入してください。
3. 部品番号を表示していない部品は供給できません。
4. ▲印の部品は安全上重要な部品です。交換するときは、安全および性能維持のため必ず指定の部品をご使用ください。
5. ★印のついている部品は分解図中には記載していません。
6. カーボン抵抗器 ±5%、1/4W 型は記載していません。定数は回路図を参照願います。
7. カーボンチップ抵抗器 1/16W 型は記載していません。定数は回路図を参照願います。
8. 部品表の抵抗器、コンデンサの品名記号の読み方は表を参照してください。

### ● Resistors

Ex.: RN 14K 2E 182 G FR  
 Type Shape and performance Power Resistance Allowable error Others

RD : Carbon	2B : 1/8W	F : ±1%	P : Pulse-resistant type
RC : Composition	2E : 1/4W	G : ±2%	NL : Low noise type
RS : Metal oxide film	2H : 1/2W	J : ±5%	NB : Non-burning type
RW : Winding	3A : 1W	K : ±10%	FR : Fuse-resistor
RN : Metal film	3D : 2W	M : ±20%	F : Lead wire forming
RK : Metal mixture	3F : 3W		
	3H : 5W		

**\* Resistance**

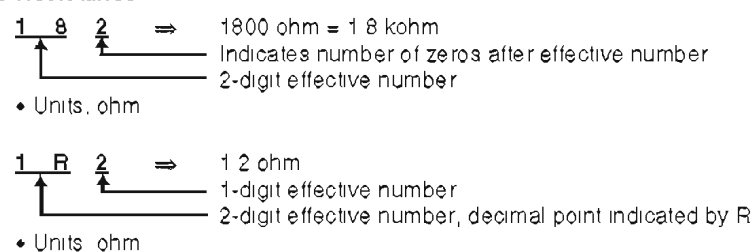

### ● 抵抗器

例) RN 14K 2E 182 G FR  
 種類 形状特性 電力 抵抗値 許容差 その他

RD : カーボン	2B : 1/8 W	F : ±1%	P : 耐パルス形
RC : 固定体	2E : 1/4 W	G : ±2%	NL : 低雑音形
RS : 金属系皮膜	2H : 1/2 W	J : ±5%	NB : 不燃形
RW : 巻線	3A : 1 W	K : ±10%	FR : ヒューズ抵抗
RN : 金属皮膜	3D : 2 W	M : ±20%	F : リード線成形
RK : 金属混合体	3F : 3 W		
	3H : 5 W		

**\* 抵抗値**

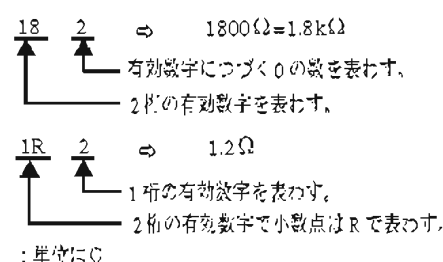

### ● Capacitors

Ex.: CE 04W 1H 2R2 M BP  
 Type Shape and performance Dielectric strength Capacity Allowable error Others

CE : Aluminum foil electrolytic	0J : 6.3V	F : ±1%	HS : High stability type
CA : Aluminum solid electrolytic	1A : 10V	G : ±2%	BP : Non-polar type
CS : Tantalum electrolytic	1C : 16V	J : ±5%	HR : Ripple-resistant type
CQ : Film	1E : 25V	K : ±10%	DL : For charge and discharge
CK : Ceramic	1V : 35V	M : ±20%	HF : For assuring high frequency
CC : Ceramic	1H : 50V	Z : +80%	U : UL part
CP : Oil	2A : 100V	-20%	C : CSA part
CM : Mica	2B : 125V	P : +100%	W : UL-CSA type
CF : Metallized	2C : 160V	-0%	F : Lead wire forming
CH : Metallized	2D : 200V	C : ±0.25pF	
	2E : 250V	D : ±0.5pF	
	2H : 500V	= : Others	
	2J : 630V		

**\* Capacity (electrolyte only)**

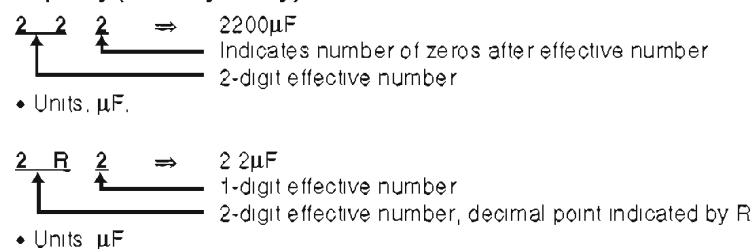

**\* Capacity (except electrolyte)**

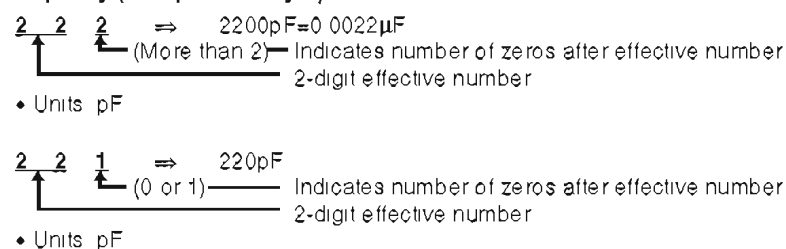

● When the dielectric strength is indicated in AC, "AC" is included after the dielectric strength value

### ● コンデンサ

例) CE 04W 1H 2R2 M BP  
 種類 形状特性 耐圧 容量 許容差 その他

CE : アルミ箔電解	0J : 6.3 V	F : ±1%	HS : 高安定形
CA : アルミ固体電解	1A : 10 V	G : ±2%	BP : 無極性形
CS : タンタル電解	1C : 16 V	J : ±5%	HR : 耐リップル形
CQ : フィルム	1E : 25 V	K : ±10%	DL : 充放電対策用
CK : セラミック	1V : 35 V	M : ±20%	HP : 高周波保証用
CC : セラミック	1H : 50 V	Z : +80%	U : UL 部品
CP : オイル	2A : 100 V	-20%	C : CSA 部品
CM : マイカ	2B : 125 V	P : +100%	W : UL-CSA 部品
CF : メタライズド	2C : 160 V	-0%	F : リード線成形
CH : メタライズド	2D : 200 V	C : ±0.25pF	
	2E : 250 V	D : ±0.5pF	
	2H : 500 V	= : その他	
	2J : 630 V		

**\* 容量値**

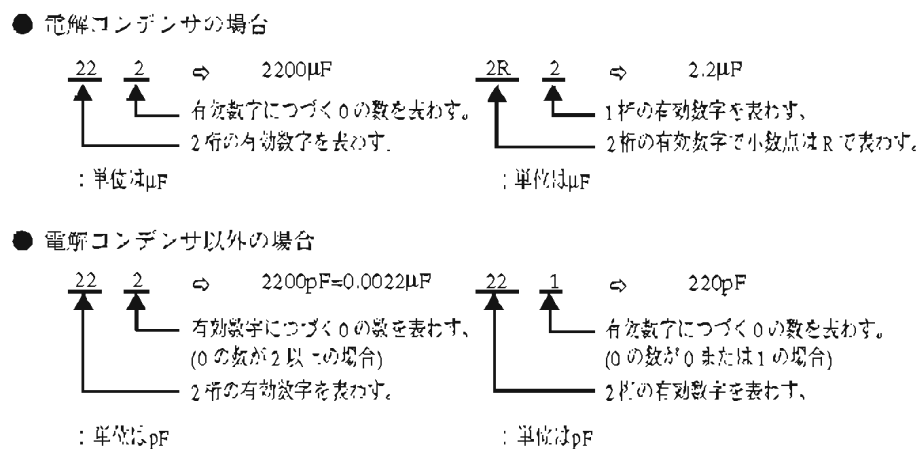

● 耐圧を交流で表示する場合は、耐圧表示の次に「AC」を表示します。

## PARTS LIST OF P.W.B. UNIT

\*本表に記載されている部品は、補修用部品のため製品に使用している部品とは一部、形状、寸法などが異なる場合があります

Note: The symbols in the column "Remarks" indicate the following destinations.

E3: U.S.A. & Canada model

E2: Europe model

JP: Japan model

## GU-3607 MAIN P.W.B. UNIT ASS'Y

Ref. No.	Part No.	Part Name	Remarks	Q'ty	New
<b>SEMICONDUCTORS GROUP</b>					
IC101	00D 262 3044 001	MN102H730F			
IC102	00D GEN 6696	SYSTEM ROM SUB ASS'Y	8M FLASH MEMORY(70N)		
IC103	00D 263 1034 906	PST600H-T			
IC104	00D 262 1953 903	TC7WU04F +C			
IC105	00D 262 3305 902	SN74LV393APW			
IC106	00D 262 3166 905	PCM1748E(TAPE) +C			
IC108	00D 262 2518 907	SN74LV74APW-EL2 +C			
IC109	00D 262 2517 908	SN74LV08APW-EL2 +REF			
IC110	00D 263 1079 903	BA033FP +C			
IC201	00D 262 3398 003	MN6627933			
IC202	00D 262 3159 909	AN8785SB			
IC203	00D 262 3160 901	AN22002A			
IC207	00D 263 0615 902	BA15218F-DXE2 +C			
IC210	00D 262 3401 000	64M SDRAM(TSOP)			
IC401	00D 262 3399 002	ADSP-BF531(LQFP)			
IC402	00D 262 3407 004	128M SDRAM(TSOP)PBF			
IC403,404	00D 262 2640 901	SN74LV245APW-EL2			
IC405	00D 262 2959 906	SN74LV244APW +REF			
IC406	00D 262 2640 901	SN74LV245APW-EL2			
IC408	00D 262 2518 907	SN74LV74APW-EL2 +C			
IC409	00D 262 2516 909	SN74LV32APW-EL2 +C			
IC410	00D 262 3400 904	TPC6103			
IC411	00D 262 2948 904	SN74LV86APW +REF			
TR101	00D 269 0082 902	DTC114EKT96 +C			
TR201	00D 272 0125 904	2SB709A +C			
TR202,203	00D 269 0082 902	DTC114EKT96 +C			
D101	00D 276 0559 909	DAP202KT146 +C			
D401	00D 276 0559 909	DAP202KT146 +C			
D402	00D 276 0750 902	RB521S-30TE61 +REF			
LD101	00D 393 9633 008	SELU1250CM(RED)			
<b>RESISTORS GROUP</b>					
R205	00D 244 2043 937	RS14B3A100JNBST(S)			
<b>CAPACITORS GROUP</b>					
C101	00D 257 0512 903	CK73F1E104ZT +1608			
C102	00D 254 4533 918	CE04W0J470MT SMG/RE3			
C103-107	00D 257 0512 903	CK73F1E104ZT +1608			
C108	00D 254 4533 918	CE04W0J470MT SMG/RE3			
C109	00D 254 4300 947	CE04W0J470MT(SRE)			
C110-113	00D 257 0512 903	CK73F1E104ZT +1608			



Ref. No.	Part No.	Part Name	Remarks	Q'ty	New
C114	00D 254 4302 916	CE04W1A100MT(SRE)			
C115	00D 257 0509 929	CK73B1H102KT +1608			
C116	00D 257 0512 903	CK73F1E104ZT +1608			
C117	00D 254 4533 918	CE04W0J470MT SMG/RE3			
C118,119	00D 257 0512 903	CK73F1E104ZT +1608			
C120	00D 257 0504 908	CC73CH1H220JT +1608			
C121	00D 257 0511 904	CK73F1H103ZT +1608			
C122	00D 257 0512 903	CK73F1E104ZT +1608			
C123	00D 257 0509 929	CK73B1H102KT +1608			
C124	00D 254 4533 918	CE04W0J470MT SMG/RE3			
C125	00D 257 0504 908	CC73CH1H220JT +1608			
C126	00D 257 0516 954	CK73B1E104KT +1608			
C127	00D 254 4300 918	CE04W0J100MT(SRE)			
C128	00D 257 0511 904	CK73F1H103ZT +1608			
C129	00D 254 4299 906	CE04W1C100MT(SRE)			
C130,131	00D 257 0516 954	CK73B1E104KT +1608			
C132	00D 254 4302 916	CE04W1A100MT(SRE)			
C133	00D 254 4302 958	CE04W1A470MT(SRE)			
C134,135	00D 257 0512 903	CK73F1E104ZT +1608			
C136	00D 254 4302 958	CE04W1A470MT(SRE)			
C137,138	00D 257 0502 997	CC73CH1H7R0DT +1608			
C139	00D 257 0516 954	CK73B1E104KT +1608			
C140	00D 257 0501 901	CK73B1H103KT (1608) +1608			
C141	00D 257 0509 929	CK73B1H102KT +1608			
C142	00D 257 0516 954	CK73B1E104KT +1608			
C143	00D 257 0501 901	CK73B1H103KT (1608) +1608			
C144	00D 257 0509 929	CK73B1H102KT +1608			
C145	00D 257 0516 954	CK73B1E104KT +1608			
C146	00D 257 0501 901	CK73B1H103KT (1608) +1608			
C147-151	00D 257 0509 929	CK73B1H102KT +1608			
C201	00D 257 0512 903	CK73F1E104ZT +1608			
C202	00D 257 0509 929	CK73B1H102KT +1608			
C203	00D 257 0512 903	CK73F1E104ZT +1608			
C204	00D 257 0509 929	CK73B1H102KT +1608			
C205	00D 257 0516 909	CK73B1E223KT +1608			
C206	00D 257 0512 903	CK73F1E104ZT +1608			
C207	00D 256 1058 984	CF93A1H124JT (JL)			
C208	00D 254 4533 918	CE04W0J470MT SMG/RE3			
C210	00D 254 4533 918	CE04W0J470MT SMG/RE3			
C211,212	00D 257 0512 903	CK73F1E104ZT +1608			
C213	00D 257 0509 929	CK73B1H102KT +1608			
C214	00D 257 0512 903	CK73F1E104ZT +1608			
C216	00D 257 0510 950	CK73B1H682KT +1608			
C217-220	00D 257 0509 990	CK73B1H222KT +1608			
C221	00D 254 4536 915	CE04W1A470MT SMG/RE3			
C222,223	00D 257 0516 909	CK73B1E223KT +1608			
C224	00D 257 0512 903	CK73F1E104ZT +1608			
C227	00D 257 0512 903	CK73F1E104ZT +1608			
C228	00D 254 4536 915	CE04W1A470MT SMG/RE3			
C229	00D 257 0504 937	CC73CH1H300JT +1608			
C231,232	00D 254 4302 958	CE04W1A470MT(SRE)			
C233	00D 254 4533 947	CE04W0J331MT SMG/RE3			
C234	00D 257 0512 903	CK73F1E104ZT +1608			
C236	00D 256 1059 912	CF93A1H224JT (JL)			
C237	00D 257 0512 903	CK73F1E104ZT +1608			
C238	00D 257 0501 914	CK73B1H123KT +1608			

Ref. No.	Part No.	Part Name	Remarks	Q'ty	New
C239	00D 257 0510 947	CK73B1H562KT +1608			
C240	00D 257 0516 909	CK73B1E223KT +1608			
C241	00D 257 0501 927	CK73B1H153KT +1608			
C242	00D 257 0506 919	CC73CH1H680JT +1608			
C243	00D 257 0512 903	CK73F1E104ZT +1608			
C244	00D 254 4302 974	CE04W1A101MT(SRE)			
C245	00D 257 0507 950	CC73CH1H271JT +1608			
C246	00D 257 0506 993	CC73CH1H151JT +1608			
C250	00D 257 0512 903	CK73F1E104ZT +1608			
C251	00D 254 4524 969	CE04W1H3R3MT SMG/RE3			
C252	00D 254 4533 921	CE04W0J101MT SMG/RE3			
C253	00D 257 0512 903	CK73F1E104ZT +1608			
C257	00D 254 4533 918	CE04W0J470MT SMG/RE3			
C261,262	00D 254 4299 906	CE04W1C100MT(SRE)			
C263,264	00D 257 0510 918	CK73B1H332KT +1608			
C265,266	00D 257 0506 935	CC73CH1H820JT +1608			
C267,268	00D 257 0512 903	CK73F1E104ZT +1608			
C274	00D 257 0512 903	CK73F1E104ZT +1608			
C280	00D 254 4302 958	CE04W1A470MT(SRE)			
C281	00D 257 0512 903	CK73F1E104ZT +1608			
C282	00D 254 4300 918	CE04W0J100MT(SRE)			
C283-285	00D 257 0512 903	CK73F1E104ZT +1608			
C291,292	00D 257 0512 903	CK73F1E104ZT +1608			
C293,294	00D 254 4193 947	CE04W1C101MT (SRA)			
C295	00D 257 0512 903	CK73F1E104ZT +1608			
C298	00D 257 0512 903	CK73F1E104ZT +1608			
C301	00D 257 0512 903	CK73F1E104ZT +1608			
C306	00D 257 0512 903	CK73F1E104ZT +1608			
C401	00D 257 0509 929	CK73B1H102KT +1608			
C402	00D 257 0512 903	CK73F1E104ZT +1608			
C403	00D 254 4533 918	CE04W0J470MT SMG/RE3			
C404-406	00D 257 0512 903	CK73F1E104ZT +1608			
C407	00D 254 4533 918	CE04W0J470MT SMG/RE3			
C408-412	00D 257 0512 903	CK73F1E104ZT +1608			
C413	00D 254 4533 918	CE04W0J470MT SMG/RE3			
C414	00D 254 4302 958	CE04W1A470MT(SRE)			
C415-419	00D 257 0512 903	CK73F1E104ZT +1608			
C420	00D 254 4533 918	CE04W0J470MT SMG/RE3			
C421,422	00D 257 0512 903	CK73F1E104ZT +1608			
C423	00D 254 4533 918	CE04W0J470MT SMG/RE3			
C424-429	00D 257 0512 903	CK73F1E104ZT +1608			
C431-438	00D 257 0512 903	CK73F1E104ZT +1608			
C439	00D 254 4533 918	CE04W0J470MT SMG/RE3			
C440-443	00D 257 0512 903	CK73F1E104ZT +1608			
<b>OTHERS PARTS GROUP</b>					
CX121	00D 205 1314 934	12P FFC BASE(9616S)Y			
CX181	00D 205 1314 947	18P FFC BASE(9616S)Y			
CX251	00D 205 1260 020	25P FFC BASE(9610S)T			
CX301	00D 205 1318 008	20P FFC BASE(9604S)Y			
FB103-119	00D 235 0130 903	CHIP EMIFIL(11A121) +1608			
FB202-204	00D 235 0106 908	CHIP EMIFIL (21A05) +C			
FB401	00D 235 0158 901	CHIP BEADS(18PG121) +1608			

	Ref. No.	Part No.	Part Name	Remarks	Q'ty	New
	X101	00D 399 0880 900	CSTLS32M0X53			
	X102	00D 399 0907 003	X'TAL(11.2896MHZ)			
	X201	00D 399 0978 906	CSTCG25M0V53-R0			
	X401	00D 399 0978 906	CSTCG25M0V53-R0			

## GU-3608 PANEL P.W.B. UNIT ASS'Y

Ref. No.	Part No.	Part Name	Remarks	Q'ty	New
<b>SEMICONDUCTORS GROUP</b>					
IC601	00D 262 3228 908	M66005AFP +C			
IC602	00D 262 2745 903	BU2090F(E2) +C			
IC603	00D 262 2514 901	SN74LV138APW-EL2 +C			
IC701	00D 269 0203 008	GP1A70R			
IC751	00D 262 1953 903	TC7WU04F +C			
IC809	00D 263 1092 003	BA05T			
IC810	00D 263 0809 006	NJM7805FA(S)			
IC811	00D 263 0554 005	NJM7905FA			
TR601,602	00D 271 0260 905	2SA1036KT146(S/R) +C			
TR603,604	00D 269 0082 902	DTC114EKT96 +C			
TR605	00D 271 0260 905	2SA1036KT146(S/R) +C			
TR606	00D 269 0082 902	DTC114EKT96 +C			
TR607	00D 271 0260 905	2SA1036KT146(S/R) +C			
TR751-753	00D 273 0460 905	KTC2875B-RTK +C			
TR754	00D 269 0082 902	DTC114EKT96 +C			
TR755	00D 269 0083 901	DTA114EKT96 +C			
TR756	00D 269 0082 902	DTC114EKT96 +C			
TR801	00D 272 0083 004	2SB1185(E/F)			
D601-606	00D 276 0559 909	DAP202KT146 +C			
D608	00D 276 0559 909	DAP202KT146 +C			
D611-613	00D 276 0559 909	DAP202KT146 +C			
D751	00D 276 0717 903	1SS355 TE-17 +C			
D752	00D 276 0559 909	DAP202KT146 +C			
D753	00D 276 0560 901	DAN202KT146 +C			
D804	00D 276 0704 903	1SR35-400A(T93X)			
D805	00D 276 0623 000	D3SBA20			
D807	00D 276 0704 903	1SR35-400A(T93X)			
D808-811	00D 276 0553 905	1SR35-200A(T93X)			
ZD801	00D 276 0760 947	MTZJ5.1B T77			
ZD802	00D 276 0632 907	MTZJ27DT77			
LD601-604	00D 393 9606 909	SEL6927A(TP5)			
LD605	00D 393 9543 923	SLR-325DC (ORG) TAPE			
LD606	00D 393 9606 909	SEL6927A(TP5)			
LD607,608	00D 393 9543 910	SLR-325MC (GRN) TAPE			
LD609	00D 393 9604 901	SEL6227S(TP5)			
LD610	00D 393 9605 900	SEL6427EP(TP5)			
LD611	00D 393 9543 923	SLR-325DC (ORG) TAPE			
LD612	00D 393 9606 909	SEL6927A(TP5)			
LD613,614	00D 393 9543 910	SLR-325MC (GRN) TAPE			
LD615	00D 393 9604 901	SEL6227S(TP5)			
LD616	00D 393 9605 900	SEL6427EP(TP5)			
LD618	00D 393 9543 907	SLR-325VC (RED) TAPE			
LD619	00D 393 9543 923	SLR-325DC (ORG) TAPE			
<b>RESISTORS GROUP</b>					
VR701	00D 211 5648 119	SLIDE VOLUME (100MM)			

	Ref. No.	Part No.	Part Name	Remarks	Q'ty	New
<b>CAPACITORS GROUP</b>						
	C601 C603,604 C605 C606	00D 257 0512 903 00D 257 0512 903 00D 257 0506 951 00D 257 0511 920	CK73F1E104ZT +1608 CK73F1E104ZT +1608 CC73CH1H101JT +1608 CK73F1H473ZT +1608			
	C607 C608 C609,610 C612 C613	00D 254 4300 947 00D 257 0512 903 00D 257 0509 929 00D 257 0512 903 00D 254 4302 974	CE04W0J470MT(SRE) CK73F1E104ZT +1608 CK73B1H102KT +1608 CK73F1E104ZT +1608 CE04W1A101MT(SRE)			
	C614 C701,702 C751 C752 C753	00D 254 4300 947 00D 257 0512 903 00D 257 0509 929 00D 254 4536 928 00D 257 0501 901	CE04W0J470MT(SRE) CK73F1E104ZT +1608 CK73B1H102KT +1608 CE04W1A101MT SMG/RE3 CK73B1H103KT (1608) +1608			
	C754 C755 C756,757 C758 C761,762	00D 257 0512 903 00D 254 4538 926 00D 257 0501 901 00D 257 0512 903 00D 254 4538 900	CK73F1E104ZT +1608 CE04W1C330MT SMG/RE3 CK73B1H103KT (1608) +1608 CK73F1E104ZT +1608 CE04W1C100MT SMG/RE3			
	C763,764 C766,767 C768-770 C816 C818-820	00D 257 0509 929 00D 257 0512 903 00D 257 0508 917 00D 254 4535 929 00D 257 0512 903	CK73B1H102KT +1608 CK73F1E104ZT +1608 CC73CH1H471JT +1608 CE04W1J470MT SMG/RE3 CK73F1E104ZT +1608			
	C824-826 C829 C832-835 C836 C837,838	00D 254 4536 931 00D 254 4540 707 00D 257 0512 903 00D 254 4442 711 00D 254 4539 718	CE04W1A221MT SMG/RE3 CE04W1J331MC SMG/RE3 CK73F1E104ZT +1608 CE04W1C103MC(SMG) CE04W1C222MC SMG/RE3			
⚠	C843 C846 C848,849 C853-855	00D 253 8022 707 00D 254 4541 942 00D 257 0512 903 00D 257 0501 901	CK45F2EAC103MC CE04W1E101MT SMG/RE3 CK73F1E104ZT +1608 CK73B1H103KT (1608) +1608			
<b>OTHERS PARTS GROUP</b>						
	CW031 CW041	00D 203 5280 026 00D 205 0355 046	3P KR-DS CONN.CORD 4P KR CON BASE(L)			
	CW042  CX031 CX041 CX042	00D 203 6393 022  00D 205 0355 033 00D 203 6393 022 00D 205 0343 045	4P KR-DS CON CORD  3P KR CON BASE(L) 4P KR-DS CON CORD 4P CONN.BASE(KR-PH)			
	CY021 CY201 CY251	00D 205 0581 001 00D 205 1317 009 00D 205 1316 000	2P VH CONNECTOR BASE 20P FFC BASE(9604S)T 25P FFC BASE(9610S)Y			
⚠	F801 ⚠ F801 ⚠ F801  FF805	00D 206 1087 086 00D 206 1087 099 00D 206 1057 016  00D 202 0040 909	FUSE (ET0.315A) FUSE(ET0.16A) FUSE(ATSC 0.4AT)  FUSE CLIP (TAPE)	for E3 for E2 for JP		

	Ref. No.	Part No.	Part Name	Remarks	Q'ty	New
	FH805	00D 202 0040 909	FUSE CLIP (TAPE)			
	FL601	00D 393 8076 006	FLT(13-MT-99GN)			
	JK751	00D 204 8664 008	3P PIN JACK			
	JK753	00D 204 8416 007	MINI JACK			
	L801	00D 235 0159 007	PLH10AN3711ROP2B			
	S607-614	00D 212 5604 907	TACT SWITCH-TA(ALPS)			
	S615,616	00D 212 4809 907	TACT SWITCH (MARU)			
	S617,618	00D 212 5604 907	TACT SWITCH-TA(ALPS)			
	S619	00D 212 4809 907	TACT SWITCH (MARU)			
	S620-622	00D 212 5604 907	TACT SWITCH-TA(ALPS)			
	S623	00D 212 0410 002	ROTARY ENCODER-JOG			
	S624-632	00D 212 5604 907	TACT SWITCH-TA(ALPS)			
	S650-661	00D 212 4809 907	TACT SWITCH (MARU)			
⚠	S801	00D 212 1176 015	POWER SWITCH(TV-5)			
	T751	00D 231 8063 009	PULSE TRANS			
		00D GEN 6256 -8	FUSE LABEL SUB ASS'Y	for E3, for F801		
		00D GEN 6256 -7	FUSE LABEL SUB ASS'Y	for JP, for F801		

Parts List

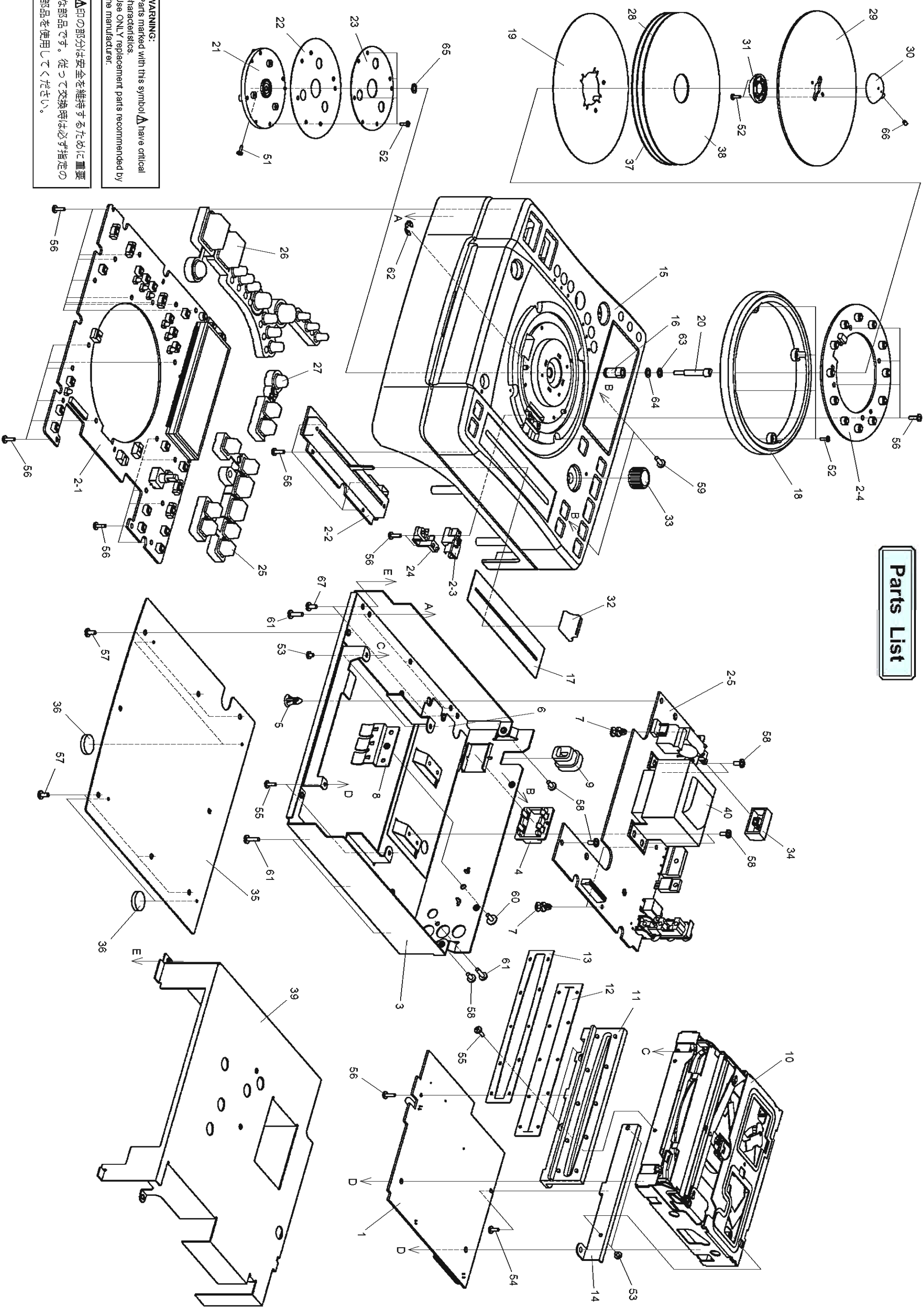

**WARNING:**  
Parts marked with this symbol  have critical characteristics.  
Use ONLY replacement parts recommended by the manufacturer.

印の部分は安全を維持するために重要な部品です。従って交換時は必ず指定の部品を使用してください。

## PARTS LIST OF EXPLODED VIEW

\*本表に記載されている部品は、補修用部品のため製品に使用している部品とは一部、形状、寸法などが異なる場合があります。

Note: The symbols in the column "Remarks" indicate the following destinations.

E3: U.S.A. & Canada model

E2: Europe model

JP: Japan model

Ref. No.	Part No.	Part Name	Remarks	Q'ty	New
1	00D GU-3607	MAIN PWB UNIT ASS'Y		1	
2	00D GU-3608	PANEL PWB UNIT ASS'Y	for E3	1	
2	00D GU-36082	PANEL PWB UNIT ASS'Y	for E2	1	
2	00D GU-3608J	PANEL PWB UNIT ASS'Y	for JP	1	
2-1		PANEL UNIT			
2-2		SLIDE VR UNIT			
2-3		DISC SENSOR UNIT			
2-4		DISC SWITCH UNIT			
2-5		POWER UNIT			
3	00D 411 2057 206	CHASSIS		1	
4	00D 146 2302 002	P.SW KNOB GUIDE		1	
5	00D 412 2741 010	P.W.B.HOLDER (H=6)		1	
6	00D 415 0935 005	PROTECT SHEET		1	
7	00D 412 2814 044	CARD SPACER (L=6)		3	
8	00D 412 5188 007	SPRING PLATE		1	
9	00D 445 0084 009	CORD BUSH	for E3	1	
9	00D 445 0056 008	CORD BUSH	for E2,JP	1	
10	00D 337 0128 004	CD MECHA (CD11-02)		1	
11	00D 443 1585 103	DISC DUIDE		1	
12	00D 415 0936 004	BLIND SHEET		1	
13	00D 415 0937 003	FIX PLATE		1	
14	00D 412 5104 007	MAIN PWB BRACKET		1	
15	00D 103 1807 307	TOP COVER ASS'Y		1	
16	00D 425 0251 003	TOP COVER BEARING		1	
17	00D 146 2365 007	FADER PLATE		1	
18	00D 146 2366 006	JOG RING		1	
19	00D 463 0960 008	SPRING PLATE		1	
20	00D 422 0671 105	DISC SHAFT		1	
21	00D 421 0796 100	WHEEL ASS'Y		1	
22	00D 421 0797 015	SCALE DISK		1	
23	00D 441 1970 000	DISK FIX PLATE		1	
24	00D 443 1573 005	S.COVER (GP1A70R)		1	
25	00D 119 0126 000	R.KEY (FUNCTION)		1	
26	00D 119 0127 106	R.KEY (PLAY/PAUSE)		1	
27	00D 119 0128 008	R.KEY (PITCH)		1	
28	00D 421 0822 003	SLIP MAT		1	
29	00D 421 0823 109	SCRATCH DISC		1	
30	00D 421 0830 008	ADAPTOR ASS'Y		1	
31	00D 421 0825 000	DISC HOLDER		1	
32	00D 113 1951 014	FADER KNOB		1	
33	00D 112 0891 004	KNOB (MARU)		1	
34	00D 113 1689 001	P.SW KNOB		1	
35	00D 105 1462 007	BOTTOM PLATE		1	
36	00D 461 0706 114	FOOT SHEET		4	
37	00D 421 0828 007	ANTI-STATIC SHEET		1	
38	00D 421 0831 007	SLIP SHEET		1	
39	00D 412 5194 004	SHIELD BRACKET		1	
40	00D 233 6473 008	POWER TRANS	T801	1	
★	41	00D 412 5197 001	EARTH BRACKET	1	
★	42	00D 206 2155 001	AC CORD W/CON.E3	for E3	1
★	42	00D 206 2089 106	AC CORD W/CON.E2	for E2	1



	Ref. No.	Part No.	Part Name	Remarks	Q'ty	New
⚠	★ 42	00D 206 2085 003	AC CORD W/CON.DOM	for JP	1	
	★ 43	00D 415 0790 062	UL TUBE (14.3) BK	for E2,JP for Ac cord		
	★ 44	00D GEN 6760	F.CAUTION LABEL SUB	for E3	1	
	★ 45	00D 009 0196 063	25P FFC (1.0)		1	
	★ 46	00D 009 0222 047	20P FFC (1.25)		1	
	★ 47	00D 513 3826 004	E2 LASER CAUTION	for E2	1	
	★ 48	00D GEN 6335 -1	R.SHEET E3	for E3	1	
	★ 48	00D GEN 6356 -1	R.SHEET E2	for E2	1	
	★ 48	00D GEN 6686	R.SHEET J	for JP	1	
	★ 49	00D GEN 6154	MANUFAC.DATE SUB ASS	for E3	1	
<b>SCREWS</b>						
	51	00D 471 3103 012	2X6 CBS		1	
	52	00D 473 7506 022	2X6 CBTS(P)-B		10	
	53	00D 471 3802 012	2.6X3 CBS-Z		4	
	54	00D 473 7001 035	2.6X6 CBTS (S)-Z		1	
	55	00D 471 3813 014	2.6X8 CBS-B		4	
	56	00D 473 7505 007	2.6X8 CBTS (P)-Z		32	
	57	00D 473 7015 005	3X6 CBTS(S)-B		6	
	58	00D 473 7002 005	3X6 CBTS(S)-Z		8	
	59	00D 473 7002 021	3X8 CBTS (S)-B		2	
	60	00D 473 8007 083	3X8 CUP SCREW		1	
	61	00D 473 7508 017	3X10 CBTS (P)-B		7	
	62	00D 476 1005 007	5 E RING ZNP		1	
	63	00D 475 1161 016	WASHER		1	
	64	00D 475 1187 016	WASHER 7/4.1		1	
	65	00D 477 0274 007	WASHER		1	
	66	00D 474 4319 008	2.6X10 BSS (A)		1	
	67	00D 473 7002 034	3X6 CBTS (S)-B		2	



## PARTS LIST OF CD MECHANISM UNIT

\*本表に記載されている部品は、補修用部品のため製品に使用している部品とは一部、形状、寸法などが異なる場合があります。

Ref. No.	Part No.	Part Name	Remarks	Q'ty	New
SV1	00D 964 0012 006	SVP-CHCL		1	
SV2	00D 964 0012 103	SVP-GD		1	
SV3	00D 964 0012 200	SVP-ROLL		1	
1	00D 964 0012 307	ASSY CHAS BOTTOM		1	
3	00D 964 0012 404	CHASSIS TOP		1	
4	00D 964 0012 501	CAM L		1	
5	00D 964 0012 608	CAM R		1	
6	00D 964 0012 705	ASSY LVR TIMING		1	
7	00D 964 0012 802	LEVER LOCK R		1	
8	00D 964 0012 909	LEVER LOCK L		1	
18	00D 964 0013 005	BRACKET PIVOT		1	
19	00D 964 0013 102	ASSY BKT MOTOR		1	
21	00D 964 0013 209	LEAD SCREW TENSION		1	
22	00D 964 0013 306	ASSY CHAS PU 2		1	
23	00D 964 0013 403	ASSY SLED MOTOR		1	
24	00D 964 0013 500	GEAR 2ND PU		1	
25	00D 964 0013 607	GUIDE SCREW PLATE		1	
26	00D 964 0013 704	GUIDE SCREW CHIP		1	
27	00D 964 0013 801	LEAD SCREW COVER		1	
28	00D 964 0013 908	ASSY LEAD SCREW		1	
29	00D 964 0014 004	PICK UP SF-C20S		1	
30	00D 964 0014 101	OPU FPC		1	
31	00D 964 0014 208	ASSY SPINDLE MOTOR		1	
36	00D 964 0014 305	ASSY LOADING MOTOR		1	
40	00D 964 0014 402	GEAR 1ST LOAD		1	
41	00D 964 0014 509	GEAR 2ND LOAD		1	
43	00D 964 0014 606	GEAR 1ST CHUCK		1	
44	00D 964 0014 703	GEAR 2ND CHUCK		1	
47	00D 964 0014 800	ASSY SW		1	
48	00D 964 0014 907	DAMPER ASSY		3	
49	00D 964 0015 003	SPG ROLLER		2	
52	00D 964 0015 100	SPG DAMPER FR		2	
53	00D 964 0015 207	SPG DAMPER RE		2	
54	00D 964 0015 304	SPG DAMPER CE		1	
57	00D 964 0015 401	TR-UP-SP		1	
60	00D 964 0015 508	SPG CHAS PU		2	
62	00D 964 0015 605	SCREW M2X6		2	
63	00D 964 0015 702	SCREW M2X2		5	
64	00D 964 0015 809	SCREW M1.7X7		1	
65	00D 964 0015 906	SCREW M1.7X5		3	
66	00D 964 0016 002	SCREW M1.7X3		2	
67	00D 964 0016 109	SCREW M1.7X2		3	
68	00D 964 0016 206	SCREW M2X2.5		1	
69	00D 964 0016 303	PSW 1.6X4X0.25CUT		1	
70	00D 964 0016 400	PSW 1.6X5X0.5CUT		4	
72	00D 964 0016 507	PSW 2.1X4.0X0.1		1	
73	00D 964 0016 604	PSW 3.1X5.0X0.13		1	
79	00D 964 0016 701	PSW 3.1X5.0X0.2		2	

## PACKING VIEW

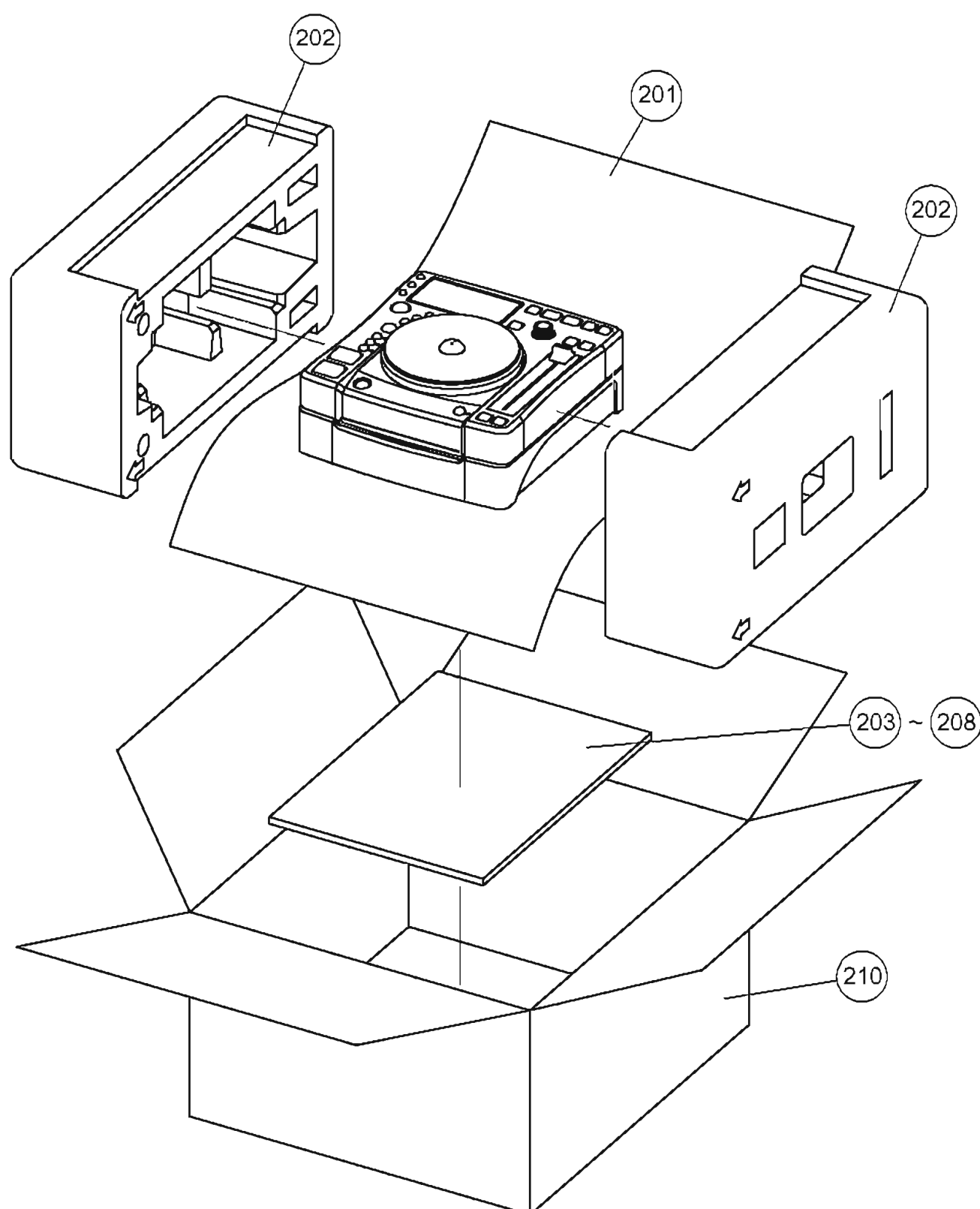

## PARTS LIST OF PACKING &amp; ACCESSORIES

\*本表に記載されている部品は、補修用部品のため製品に使用している部品とは一部、形状、寸法などが異なる場合があります。

**Note:** The symbols in the column "Remarks" indicate the following destinations.

E3: U.S.A. & Canada model

E2: Europe model

JP: Japan model

Ref. No.	Part No.	Part Name	Remarks	Q'ty	New
201	00D 505 0350 022	STYLEN PAPER		1	
202	00D 503 1486 009	CUSHION		2	
203	00D 505 0038 030	POLY COVER		1	
204	00D 511 4193 002	INST. MANUAL	for E3,E2	1	
204	00D 511 4238 006	INST. MANUAL (J)	for JP	1	
205	00D GEN 6765	INQUIRY LABEL	for JP	1	
206	00D 515 0923 304	SERVICE STATION LIST	for E3,E2	1	
206	00D 515 0918 209	SERVICE STATION LIST	for JP	1	
207	00D 203 2360 004	2P PIN CORD		1	
208	00D 515 0966 002	WARRANTY(COM.1Y)	for E3	1	
★ 209	00D GEN 6377	RECYCLING LABEL	for JP	1	
210	00D 501 2260 008	CARTON CASE		1	
★ 211	-	CONT.CARD	for E3,E2	2	
★ 212	-	BAR CODE LABEL	for E3,E2	1	
★ 212	00D 998 0006 002	POS LABEL	for JP	1	
★ 213	00D 515 0919 004	GUARANTEE CARD(S)	for JP	1	

WIRING DIAGRAM

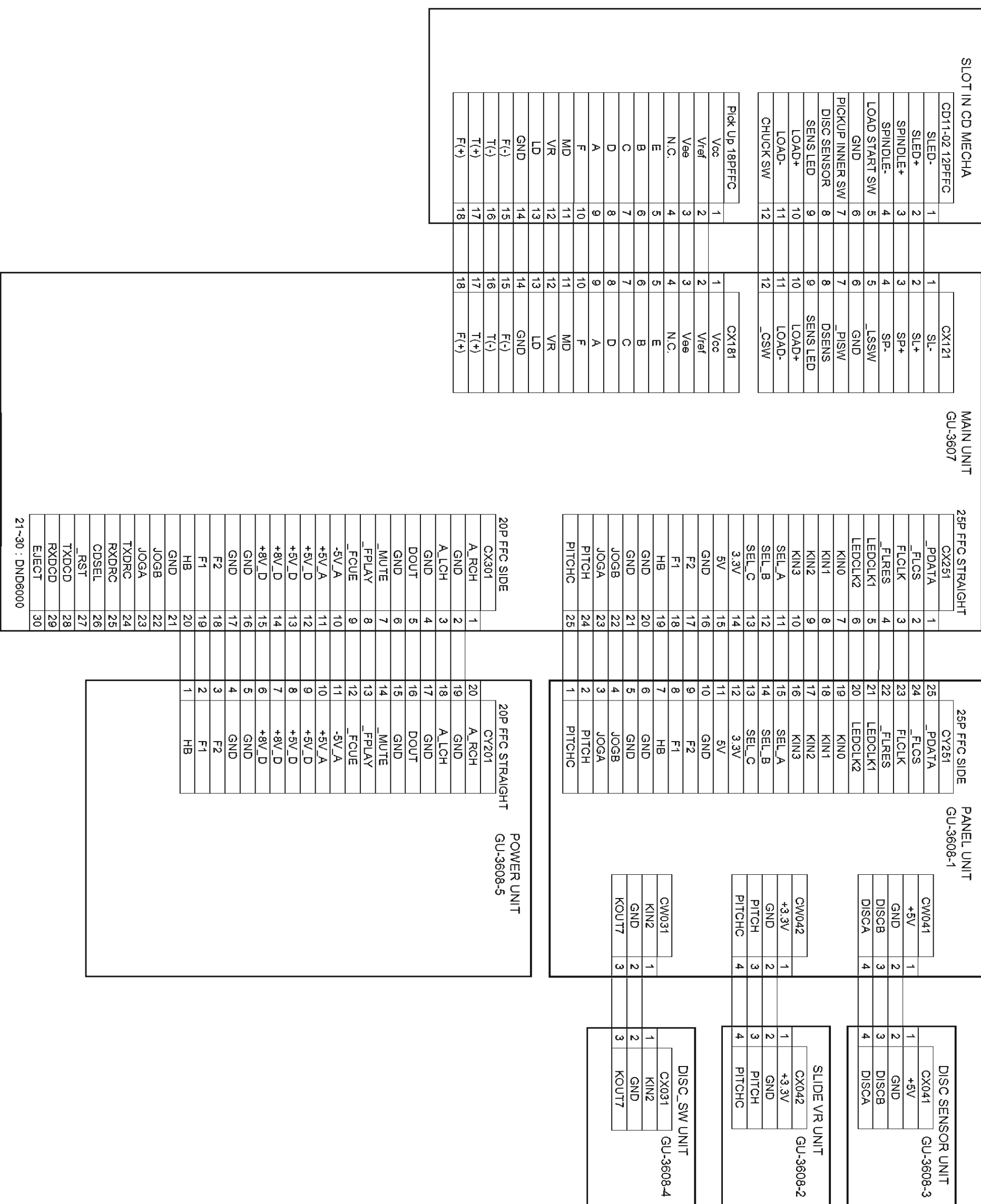

## NOTE FOR SCHEMATIC DIAGRAM

### WARNING:

Parts marked with this symbol  have critical characteristics. Use ONLY replacement parts recommended by the manufacturer.

### CAUTION:

Before returning the unit to the customer, make sure you make either (1) a leakage current check or (2) a line to chassis resistance check. If the leakage current exceeds 0.5 milliamps, or if the resistance from chassis to either side of the power cord is less than 460 kohms, the unit is defective.

### WARNING:

DO NOT return the unit to the customer until the problem is located and corrected.

### NOTICE:

ALL RESISTANCE VALUES IN OHM. k=1,000 OHM  
M=1,000,000 OHM  
ALL CAPACITANCE VALUES IN MICRO FARAD.  
P=MICRO-MICRO FARAD  
EACH VOLTAGE AND CURRENT ARE MEASURED AT  
NO SIGNAL INPUT CONDITION.  
CIRCUIT AND PARTS ARE SUBJECT TO CHANGE  
WITHOUT PRIOR NOTICE.

## 配線図について

印の部品は安全を維持するために重要な部品です。従って交換時は必ず指定の部品を使用してください。

### 注)

- (1) 指定なき抵抗値は  $\Omega$ 、k は  $k\Omega$ 、M は  $M\Omega$  を示す。
- (2) 指定なきコンデンサーの値は  $\mu F$ 、p は  $pF$  を示す。
- (3) 各部の電圧は無信号の値を示す。
- (4) この配線図は基本配線図です。改良等のため変更することがありますのでご了承ください。

1 2 3 4 5 6 7 8 9 10 11

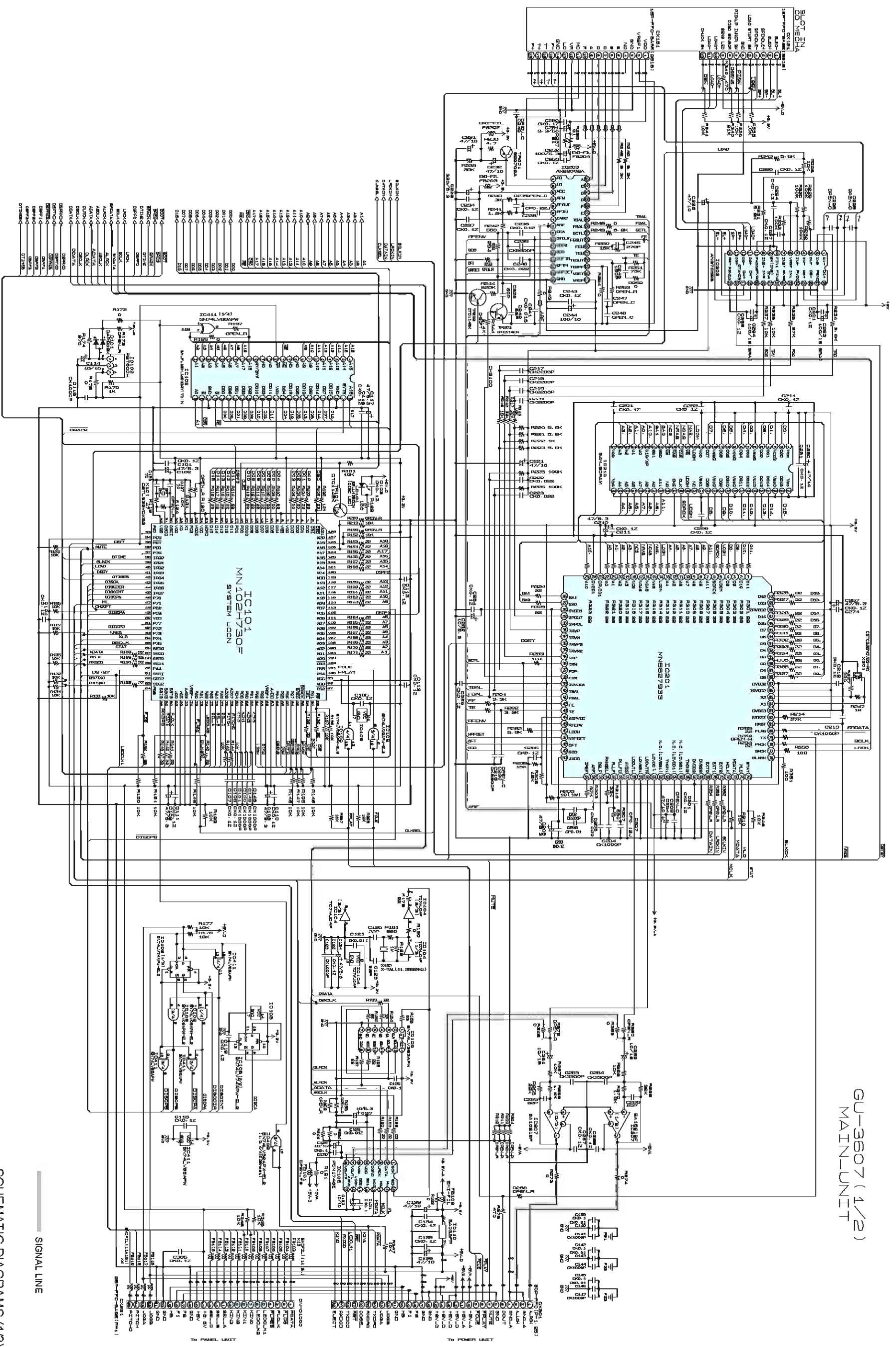

GU-3607 (1/2)  
MAIN UNIT

SCHEMATIC DIAGRAMS (1/3)  
GU-3607 MAIN UNIT (1/2)

SIGNAL LINE



1

2

3

4

5

6

7

8

9

10

11

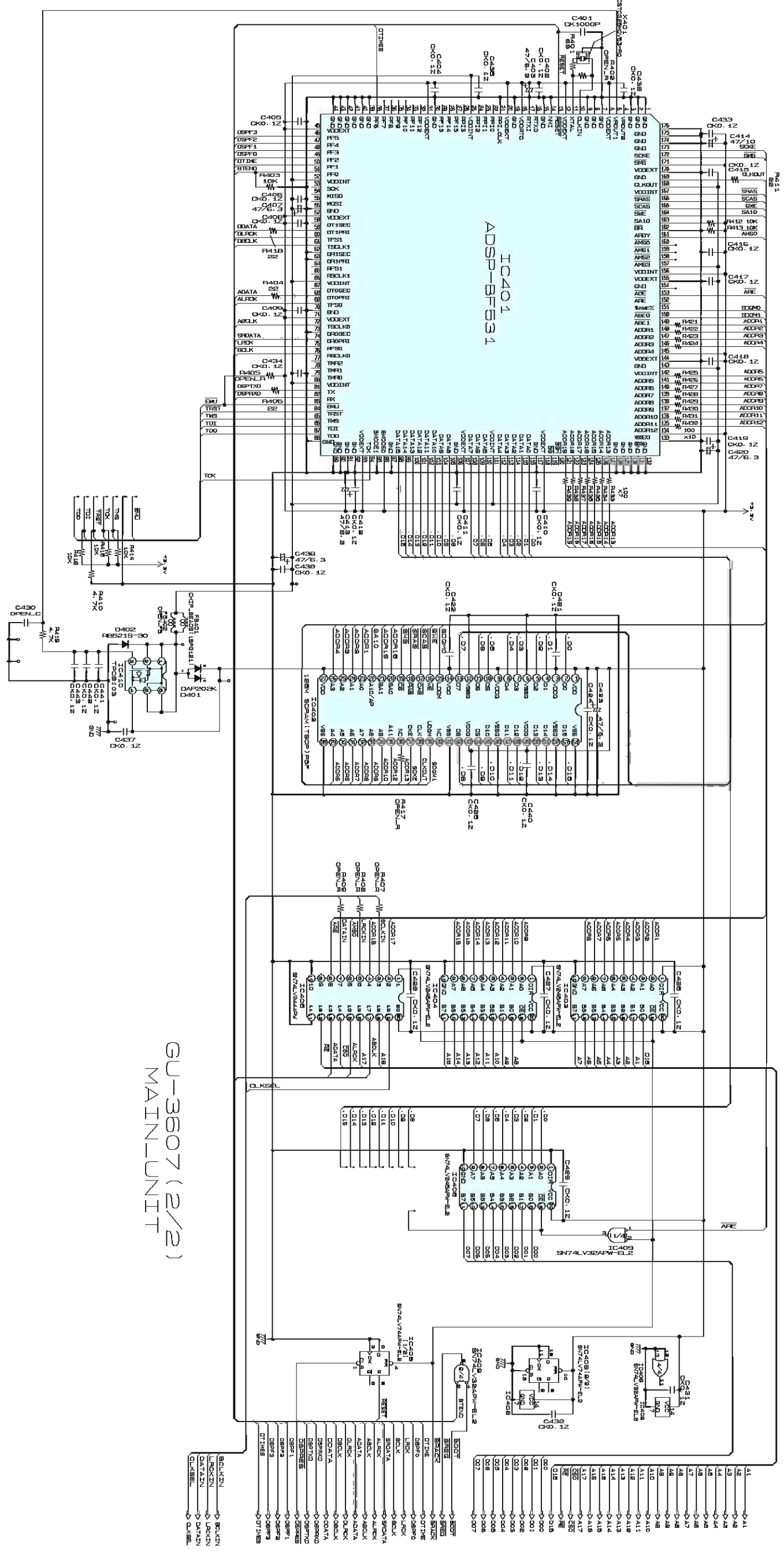

GU-3607 (2/2)  
MAIN UNIT

SIGNAL LINE

SCHEMATIC DIAGRAMS (2/3)  
GU-3607 MAIN UNIT (2/2)



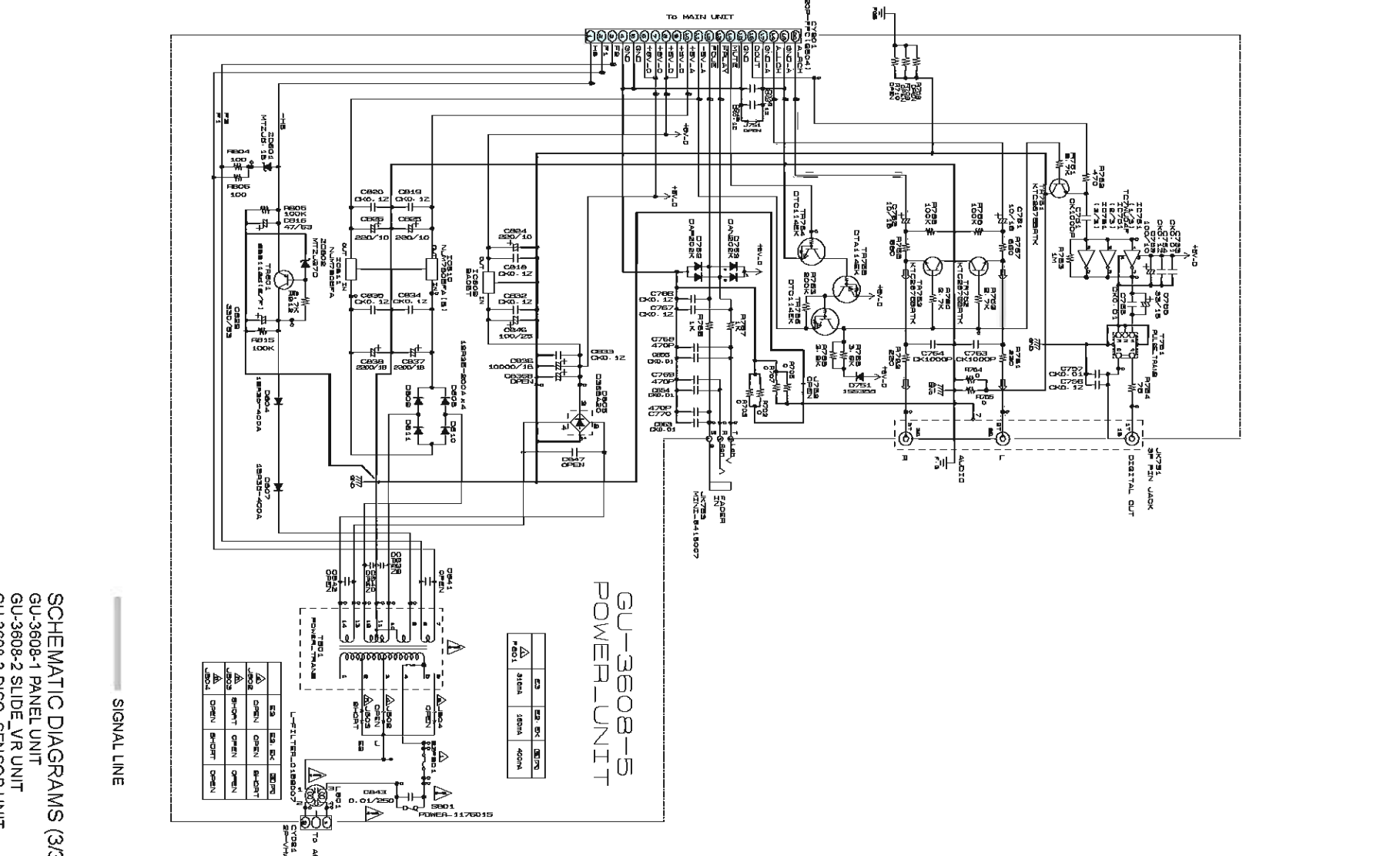
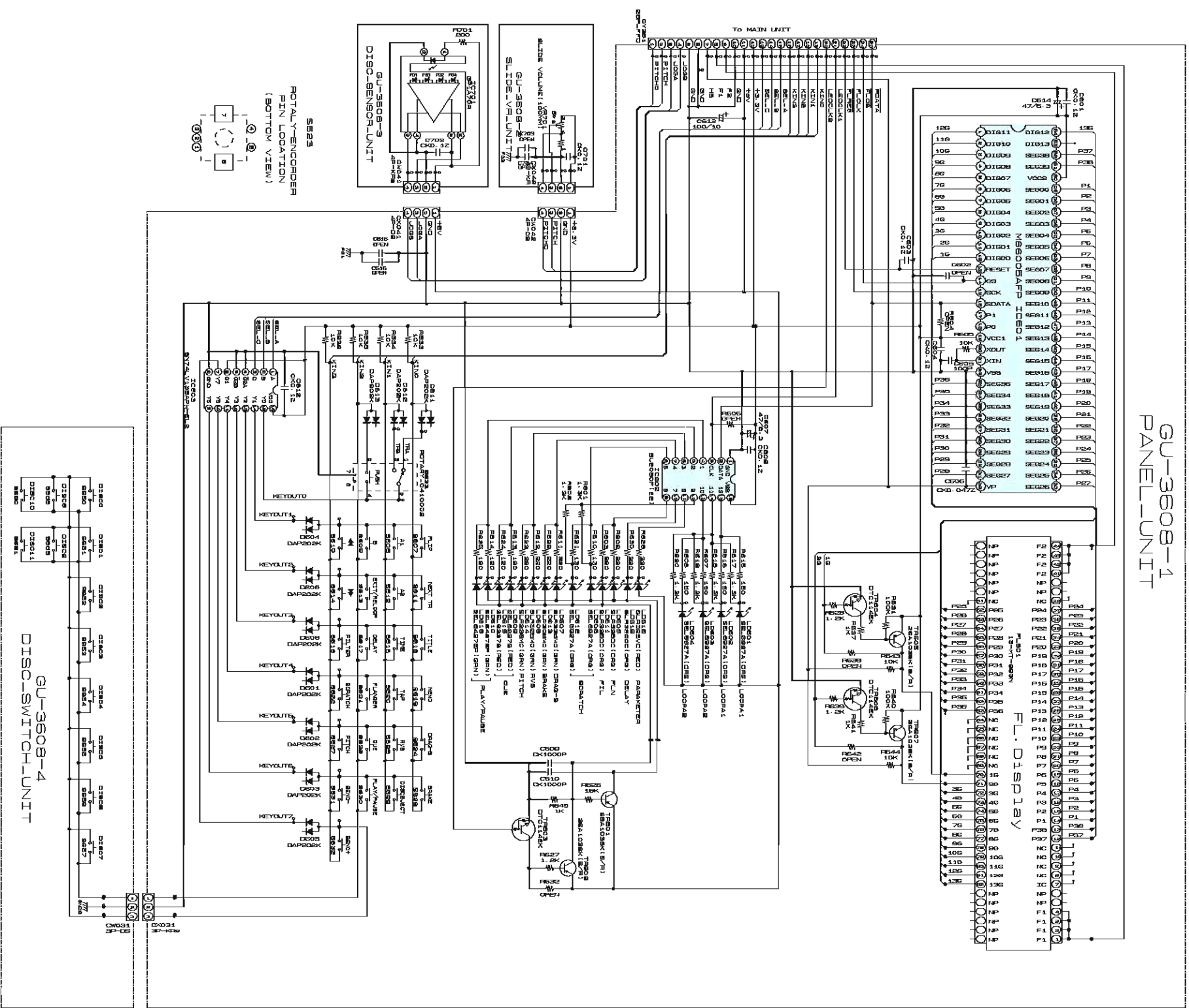

SCHEMATIC DIAGRAMS (3/3)  
 GU-3608-1 PANEL UNIT  
 GU-3608-2 SLIDE VR UNIT  
 GU-3608-3 DISC\_SENSOR UNIT  
 GU-3608-4 DISC\_SWITCH UNIT  
 GU-3608-5 POWER UNIT

SIGNAL LINE