

DENON

For U.S.A., Canada, Europe
& Japan model

Ver. 1

SERVICE MANUAL

MODEL DN-S3000

TABLE TOP SINGLE CD PLAYER

注意

サービスをおこなう前に、このサービスマニュアルを必ずお読みください。本機は、火災、感電、けがなどに対する安全性を確保するために、さまざまな配慮をおこなっており、また法的には「電気用品安全法」にもとづき、所定の許可を得て製造されております。従ってサービスをおこなう際は、これらの安全性が維持されるよう、このサービスマニュアルに記載されている注意事項を必ずお守りください。

● For purposes of improvement, specifications and design are subject to change without notice.

● 本機の仕様は性能改良のため、予告なく変更することがあります。
● 補修用性能部品の保有期間は、製造打切後8年です。

● Please use this service manual with referring to the operating instructions without fail.

● 修理の際は、必ず取扱説明書を参照の上、作業を行ってください。

● Some illustrations using in this service manual are slightly different from the actual set.

● 本文中に使用しているイラストは、説明の都合上現物と多少異なる場合があります。

DENON, Ltd.

16-11, YUSHIMA 3-CHOME, BUNKYU-KU, TOKYO 113-0034 JAPAN

SAFETY PRECAUTIONS

The following check should be performed for the continued protection of the customer and service technician.

LEAKAGE CURRENT CHECK

Before returning the unit to the customer, make sure you make either (1) a leakage current check or (2) a line to chassis resistance check. If the leakage current exceeds 0.5 milliamps, or if the resistance from chassis to either side of the power cord is less than 460 kohms, the unit is defective.

LASER RADIATION

Do not stare into beam or view directly with optical instruments, class 3A laser product.

注意

サービス、点検時には次のことにご注意願います。

●注意事項をお守りください！

サービスのとき特に注意を必要とする個所については、キャビネット、部品、シャーシなどにラベルや捺印で、注意事項を表示しています。これらの注意書きおよび取扱説明書などの注意事項を必ずお守りください。

●感電に注意！

- (1) このセットは、交流電圧が印加されていますので、通電時に内部金属部に触れると感電することがあります。従って通電サービス時には、絶縁トランスの使用や手袋の着用、部品交換には、電源プラグを抜くなどして、感電にご注意ください。
- (2) 内部には、高電圧の部分がありますので、通電時の取扱には、十分ご注意ください。

●指定部品の使用！

セットの部品は難燃性や耐電圧など安全上の特性を持ったものとなっています。従って交換部品は、使用されていたものと同じ特性の部品を使用してください。特に配線図、部品表に△印で指定されている安全上重要な部品は必ず指定のものをご使用ください。

●部品の取付けや配線の引きまわしは、元どおりに！

安全上、テープやチューブなどの絶縁材料を使用したり、プリント基板から浮かして取付けた部品があります。また内部配線は引きまわしやクランプによって発熱部品や高圧部品に接近しないように配慮されていますので、これらは必ず元どおりにしてください。

●サービス後は安全点検を！

サービスのために取り外したねじ、部品、配線などが元どおりになっているか、またサービスした個所の周辺を劣化させてしまったところがないかなどを点検し、外部金属端子部と、電源プラグの刃の間の絶縁チェックをおこなうなど、安全性が確保されていることを確認してください。

(絶縁チェックの方法)

電源コンセントから電源プラグを抜き、アンテナや、プラグなどを外し、電源スイッチを入れます。500V絶縁抵抗計を用いて、電源プラグのそれぞれの端子と、外部露出金属部〔アンテナ端子、ヘッドホン端子、マイク端子、入力端子など〕との間で、絶縁抵抗値が1MΩ以上であること、この値以下のときは、セットの点検修理が必要です。

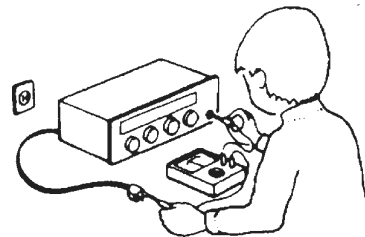

注意

安全上重要な部品について

本機に使用している多くの電気部品、および機構部品は安全上、特別な特性を持っています。この特性はほとんどの場合、外観では判別つきにくく、また、もとの部品より高い定格（定格電力、耐圧）を持ったものを使用しても安全性が維持されるとは、限りません。安全上の特性を持った部品は、このサービスマニュアルの配線図、部品表につぎのように表示していますので、必ず指定されている部品番号のものを使用願います。

(1)配線図… △マークで表示しています。

(2)部品表… △マークで表示しています。

指定された部品と異なるものを使用した場合には、感電、火災などの危険を生じる恐れがあります。

DISASSEMBLY

(Follow the procedure below in reverse order when reassembling.)

1. SLIP DISK, SLIP MAT

- (1) Remove a screw and pull out Slip Disc and Slip Mat.

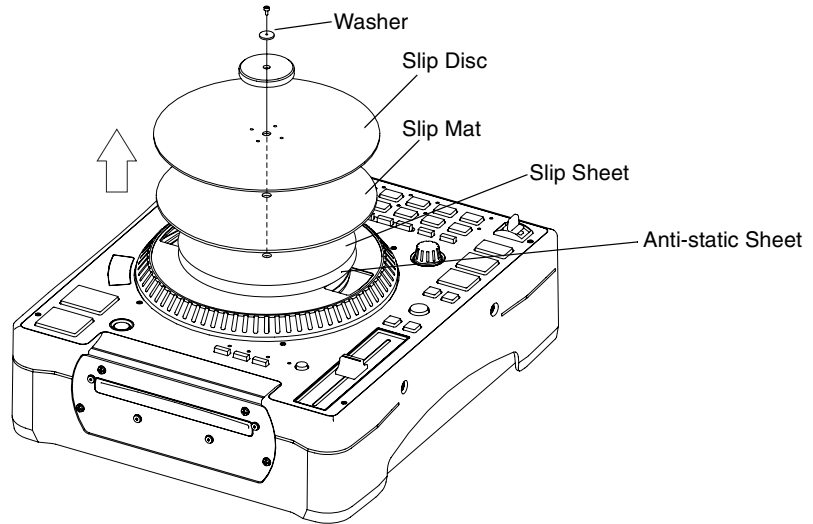

2. PLATTER

- (1) Remove Belt from Motor Pully.
- (2) Remove 3 screws and pull out Platter.

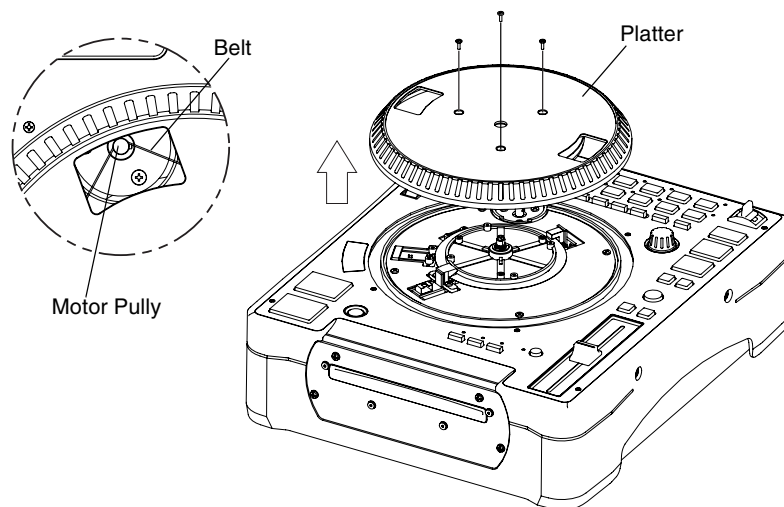

3. DRIVE UNIT

- (1) Remove 4 screws and pull out Drive Unit.
- (2) Disconnect Flat cable and Connector.
- (3) Detach Drive Unit.

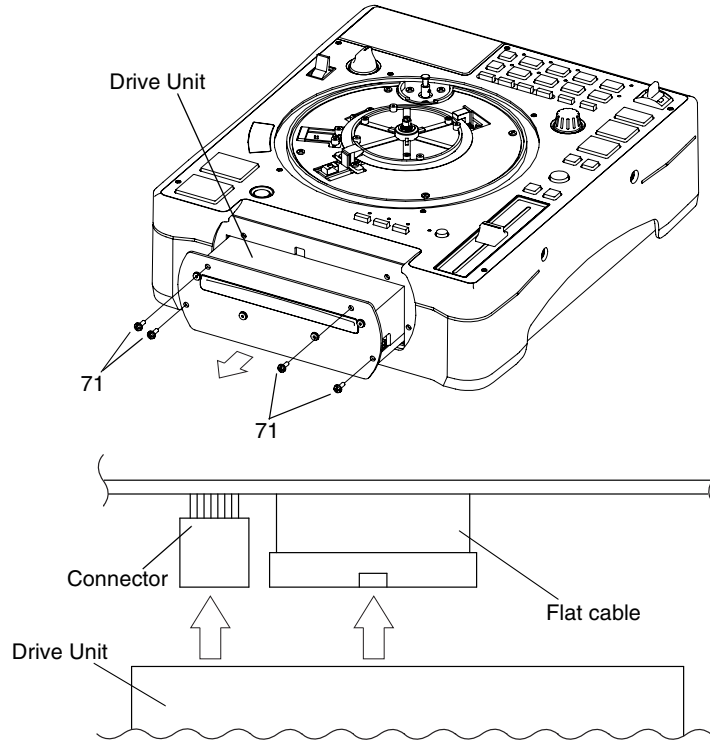

Note:

- Do not pull out aslant to prevent Flat cable damage.
- Do not fail to pull AC cord from wall outlet before disconnect the Flat cable and Connector.
If AC cord is remained plugged into wall outlet, power is kept supplied in the unit, which may cause danger.

4. COVER UNIT

- (1) Remove 5 screws and pull out Cover Unit.
- (2) Disconnect Connectors.
- (3) Detach Cover unit.

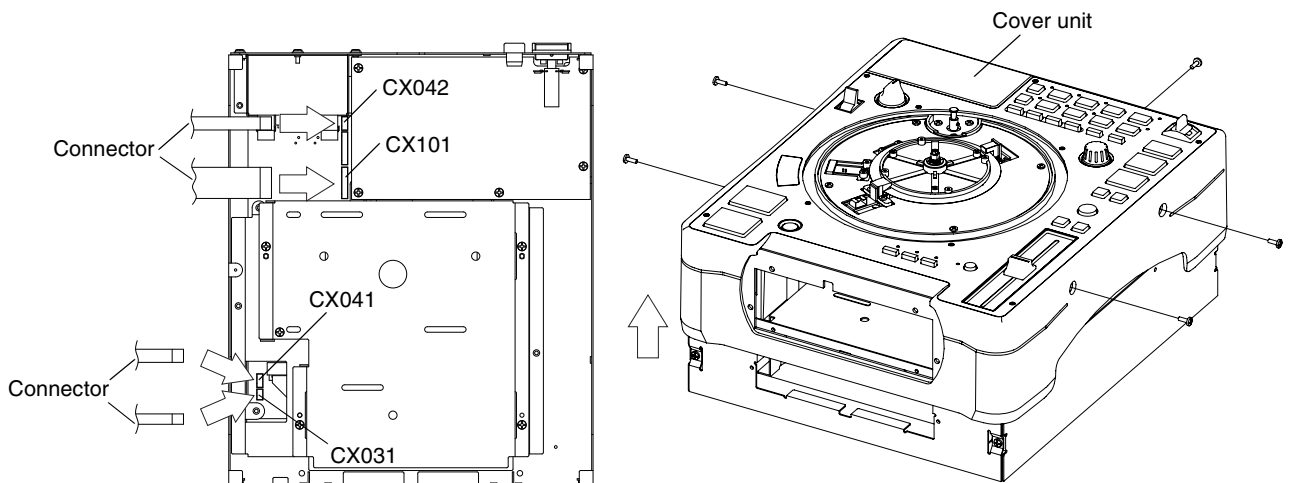

Note:

- Do not fail to pull AC cord from wall outlet before disconnect Connectors.
If AC cord is remained plugged into wall outlet, power is kept supplied in the unit, which may cause danger.

5. SENSOR AND SCALE UNITS OF PLATTER

- (1) Remove 2 screws and pull out Sensor Cover and Sensor unit.
- (2) Remove a E Ring.
- (3) Pull out Scale unit.

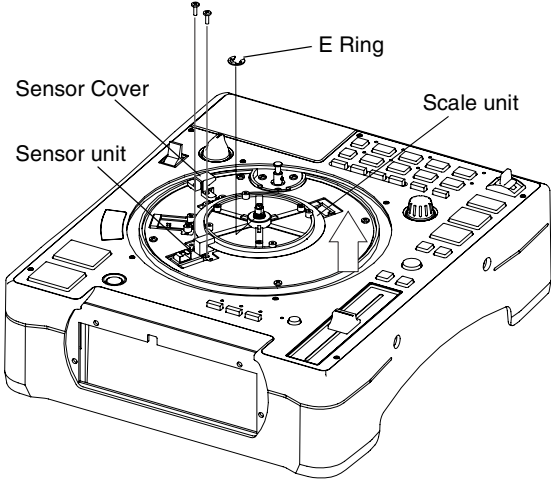

6. SENSOR AND SCALE UNITS OF SLIP DISC

- (1) Remove 2 screws and pull out Sensor Cover and Sensor unit.
- (2) Remove a screw and pull out Scale unit.

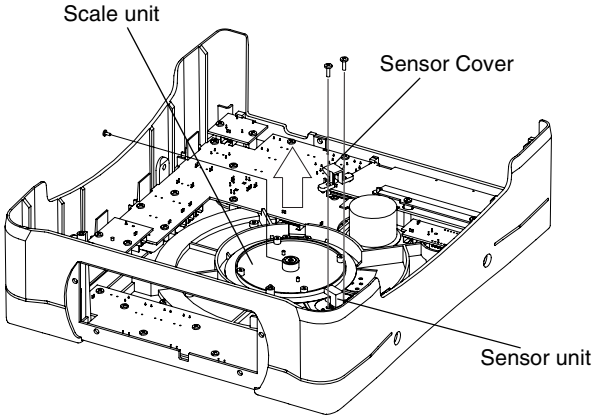

7. POWER PWB

- (1) Remove 5 screw and pull out Power PWB.

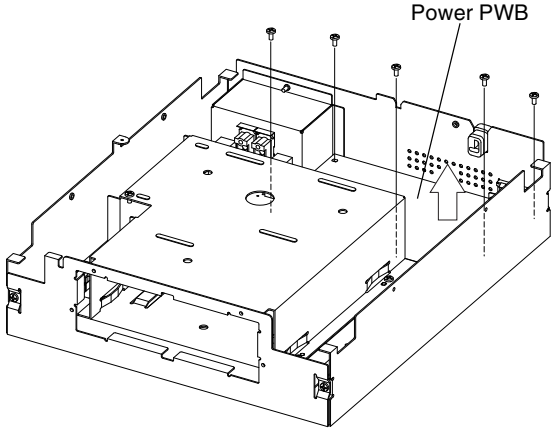

8. DSP PWB UNIT

(1) Remove 9 screws and pull out DSP PWB unit.

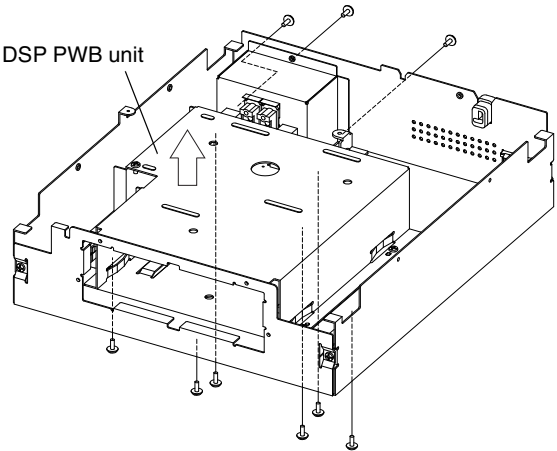

9. DRIVE COVER

(1) Remove 4 screws and pull out Drive cover.

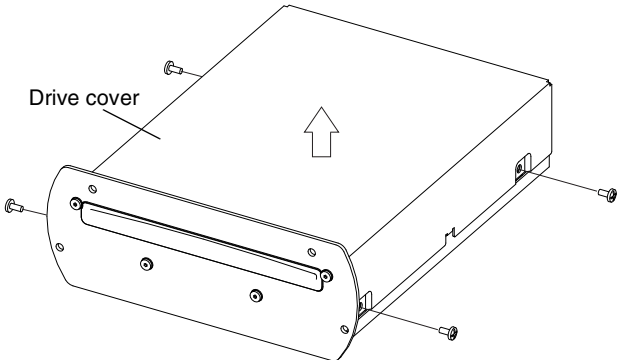

10. DRIVE

- (1) Move Drive Rack in arrow direction through the Hole on the bottom chassis. Loader frame comes out.
- (2) Pull up Loader panel while pulling it towards front.
- (3) Remove 4 screws and pull out Drive.

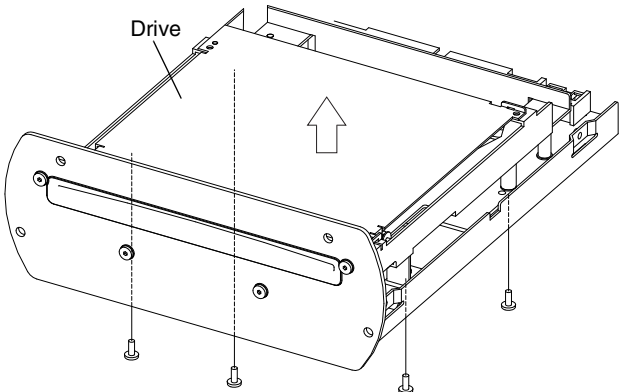

BLOCK DIAGRAM

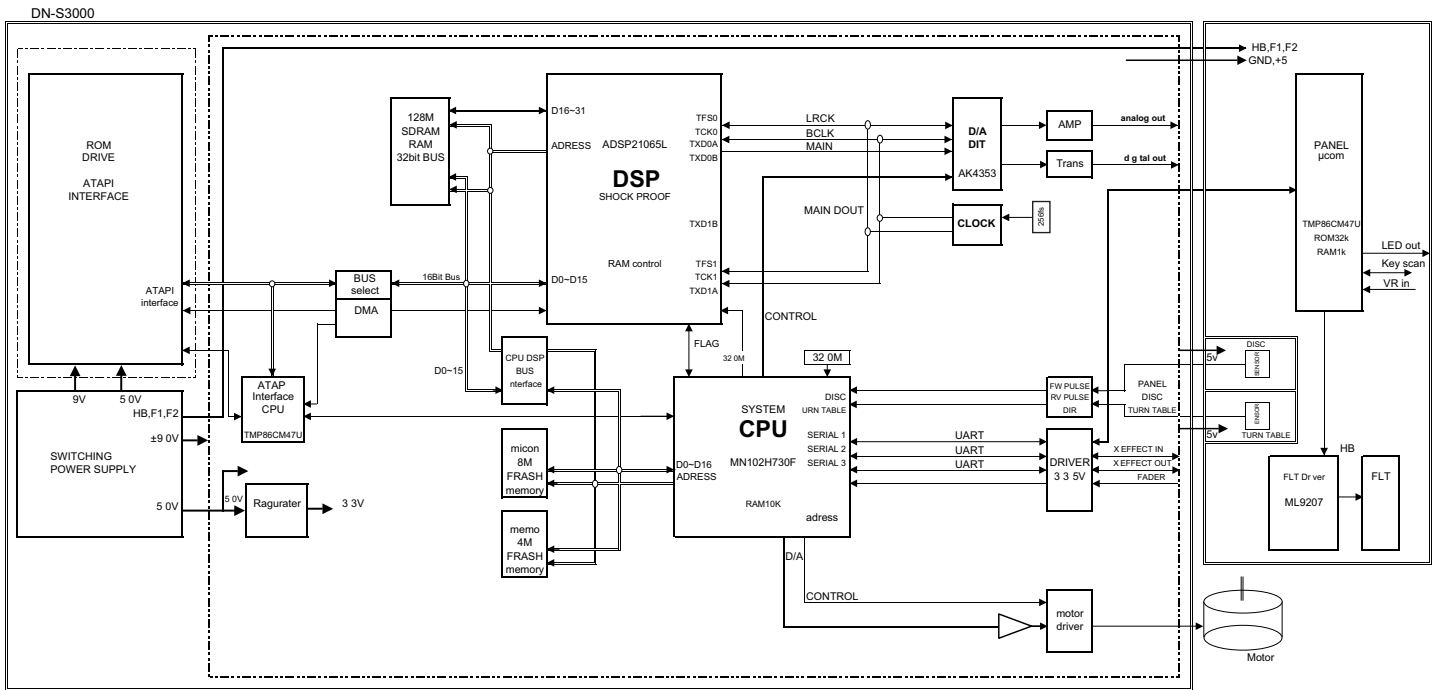

CONFIRMING THE SERVO

Required Measuring Implement

- Reference disc (TCD784 or CO 74176)

1. What is Service Program

Service program is a special program intended for confirming servo functions etc

2. Contents of Service Program

Switch on the power while pushing the PITCH BEND + button and SCRATCH MODE button at the same time. After actuating the servo program, select an aiming process number with the SELECT knob, A button, B button, SAMP button, or SAMP B button. Press the SELECT knob to execute the selected process, the process number is then displayed on the track indicator of the display. To exit from the service program, just switch off the power.

	Process No. (TRACK Indication)	Function (Character-display)	Contents
SELECT knob	01	com Version check (Version No.)	Check Version with JOG dial. 1. System com version No.: "Sys_XXXX" 2. DSP soft version No.: "Dsp_XXXX" 3. ATAPI com version No.: "Atapi_XXXX" 4. PANEL com version No.: "Panel_XXXX" 5. ROM drive mecha. com version No.: "Drive_XXXX"
	02	OPEN/CLOSE (Open/Close)	Performs open/close each time when the SELECT knob is pushed.
	03	Drive Diagnostic (Drive_Diag)	ROM drive performs operation check when the SELECT knob is pushed, and indicates the operational result. If the disc holder open, it starts the operation check after closing. It indicates "Normal_End" if it ends normal. In case of error, ROM drive error code is displayed in the character's lower portion as "E****"
	04	Drive Data Read (Data Read)	Starts continuous playback at its maximum reading speed from the beginning of disc when the SELECT knob is pushed. It halts reading and stops if the knob is pushed again.
	05	Error Code Check (Error Data)	Turn the PLATTER to display the logging error codes in the occurred order. ("Error Data" is displayed.) 10 error logs are memorized at maximum. Kinds of Error Code, displayed Error Code Table (Appears only at Heat Run and Chucking Test function) Pressing SELECT knob enters to data erase mode. ("Err Clear?" is displayed.) If the SELECT knob is pushed again, the memorized error data are cleared.
	06	Total Running Time (Total_Time)	Total time span of servo function that counted by the hour is displayed. ("Total Time" is displayed.) The display time is less than 65535 hours. Note: No time is counted if powered down within 59 minutes. Pressing SELECT knob enters to data erase mode. ("Time Clear?" is displayed.) If the SELECT knob is pushed again, the memorized time data are cleared.
	07	Automatic Servo Adjustment call	Starts automatic servo adjustment when the SELECT knob is pushed, and after completing the adjustment, sort of the used disc is indicated. Data is selectable with the PLATTER. 1. Disc check, CD/CD-RW 2. Focus gain data 3. Focus balance data 4. Focus offset data 5. Tracking gain data 6. Tracking balance data 7. Tracking offset data 8. PreAMP Tracking Sensor Gain 9. DSP Tracking Sensor Gain 10. PI offset

サービースモード

サービースモードは、サーボ状態などを確認するための特別なプログラムです。

1. サービスプログラムの内容

PITCH BEND + ボタンと SCRATCH MODE ボタンを両方押ししながら、電源を投入するとサービースモードになります。パラメータで各項目が A ボタン、B ボタン、SAMP ボタン、または SAMP B ボタンで各項目が選択できます。パラメータを押すか、PLAY/PAUSE ボタンを押すと各項目のチェック、リストを開始し、その結果を表示します。

サービースモードを終了するには、電源を切ってください。

*リファレンスディスク：TCD784、CO-74176

	項目 No. (トラック番号)	機能 キリキリ表示	内容
パラメータ	01	マイコンバージョン Version No	スクリーンを回して、バージョンを表示します。 1. システムバージョン No: "Sys_XXXX" 2. DSP ソフトバージョン No: "Dsp_XXXX" 3. ATAPI マイコンバージョン No: "Atapi_XXXX" 4. パネルマイコンバージョン No: "Panel_XXXX" 5. CDドライブマイコンバージョン No: "Drive_XXXX"
	02	CD EJECT	パラメータを押すと CD の EJECT/LOAD が選択できます。
	03	CDドライブチェック (Drive Diag)	パラメータを押すと CDドライブの動作チェックを開始します。終了すると結果を表示します。OK のときは Normal End が表示されます。
	04	ドライブデータリード (Data Read)	パラメータを押すと、データリードを開始し再生を開始します。再度、パラメータを押すと、データリードを停止し、再生を停止します。
	05	エラーコードチェック (Error Data)	通常動作時、発生した10のエラーコードが表示されます。ディスクを回すと、最大10個まで、記憶されたエラーコードが選択できます。(10コードは10コード表を参照下さい。) ・パラメータを押すと、エラーコードが消去モードになります。(Err Clear? が表示されます) 再度、パラメータを押すと、全てのエラーコードが消去されます。
	06	トータルランニングタイム (Total Time)	システム全体のトータル動作時間を表示します。1時間単位で65535時間まで計測できます。注意)59分以下で電源を切るとリセットされません。 ・パラメータを押すと、トータル時間消去モードになります。(Time Clear? が表示されます) 再度、パラメータを押すと、トータル時間が消去されます。
	07	サーボ自動調整値 読み出し (Servo Data)	パラメータを押すとサーボ自動調整を開始します。調整が終了すると、調整データが表示されます。データはスクリーンを回すことで選択できます。 1. ディスクチェック、CD/CD-RW 2. フォーカスゲインデータ 3. フォーカスバランスデータ 4. フォーカスオフセットデータ 5. トラッキングオフセットデータ 6. トラッキングバランスデータ 7. トラッキングオフセットデータ 8. プリアンプ トラッキング センサーゲイン 9. DSP トラッキング センサーゲイン 10. PI オフセット

サーボ自動調整読み出し値

	Adjustment Item	Adjustment Value indication at character portions.
1	Focus Gain	35 ~ 120
2	Focus Balance	-20 ~ +20
3	Focus Offset	-20 ~ +20
4	Tracking Gain	35 ~ 120
5	Tracking Balance	-20 ~ +20
6	Tracking Offset	-20 ~ +20

* Reference data.

	サーボ調整項目	調整 OK 範囲
1	フォーカスゲイン	35 ~ 120
2	フォーカスバランス	-20 ~ +20
3	フォーカスオフセット	-20 ~ +20
4	トラッキングゲイン	35 ~ 120
5	トラッキングバランス	-20 ~ +20
6	トラッキングオフセット	-20 ~ +20

3. TEST MODE

	Process No. (TRACK Indication)	Function (Character-display)	Contents
A button	—	Heat Run (H/R1_Normal)	Starting with the PLAY/PAUSE button, it repeats open/close of the tray and playback. All tracks are played back if the track count is less than 20. Only the first and last tracks are played back if the tracks are more than 21. When any errors, it stops and indicates error code (see Error Code Table).
B button	—	Chucking Test (H/R2_Tray)	Starting with the PLAY/PAUSE button, it repeats open/close of the tray, servo on, and TOC read. The display shows the number of the tray operation. When any errors, it stops and indicates error code (see Error Code Table).
SAMP button	—	System check (Sys_Check)	It starts system check when the PLAY/PAUSE button is pushed, and indicates the status by performing plain operational check in the system. 1. Communication judge between the system com and DSP 2. DSP SDRAM write/read operation check 3. Communication judge between the system com and ATAPI com 4. Communication judge between the ATAPI com and ROM drive 5. ROM drive operation check After finishing the check, it indicates the result on the character display lower portion. When the 1. ~ 5. items are OK, their item numbers are indicated. But if there is a NG item, its item number is not indicated.
SAMP B button	—		Judges whether PLATTER can rotate at the specified rotating speed. The message "Platter_OK" is displayed on the character display if the rotating speed meets the specification. Otherwise, "Platter_NG" is displayed.

4. Error Code Table (Appears only at Heat Run and Chucking Test function)

Error Code	Contents
E1 00	Automatic Adjustment Error
E1 01	Unable to detect disc
E1 03	Unable to adjust tracking offset
E1 04	Unable to adjust focus fine gain
E1 05	Unable to actuate focus
E1 06	Unable to adjust tracking fine gain
E2 02	Servo down during automatic adjustment
E3 00	Unable to read TOC
E4 00	Unable to close the disc holder in the regular time
E4 01	Unable to open the disc holder in the regular time
E5 00	Slide error

2. テストモード

機能キリキリ表示	内容
Aボタン ヒートランテスト H/R1 Normal	A1ボタンを押して、PLAY/PAUSEボタンを押すとテストを開始します。 ディスクの出し入れと、再生を繰り返します。 20トラック以下のディスクのときは、全てのトラックを再生します。 21トラック以上のディスクのときは、ディスク先頭トラックと最終トラックのみ再生します。エラーが発生すると、エラーコードを表示して停止します。
Bボタン チャッキングテスト H/R2 Tray	A2ボタンを押して、PLAY/PAUSEボタンを押すとテストを開始します。 ディスクの出し入れと、サーボ投入、TOCの読み込みを繰り返します。 エラーが発生すると、エラーコードを表示して停止します。
SAMPボタン システムチェック Sys Check	A3ボタンを押して、PLAY/PAUSEボタンを押すとシステムチェックを開始し、チェック終了後、その結果を表示します。 1. システムマイコンとDSPの通信チェックを行います。 2. DSPがSDRAMのリード/ライトチェックを行います。 3. システムマイコンとATAPIマイコンの通信チェックを行います。 4. ATAPIマイコンとCDドライブの通信チェックを行います。 5. CDドライブの動作チェックを行います。 全てのチェックが終了すると、キリキリ表示に結果を表示します。1～5項目のチェックがOKの場合は、OKになった項目の番号が表示されます。NGの項目が合った場合、NGになった項目の番号が表示されません。
SAMP Bボタン プラッターチェック PlatteCheck	A4ボタンを押して、PLAY/PAUSEボタンを押すとプラッターの回転チェックを開始し、チェック終了後、その結果を表示します。プラッターの回転がチェックOKのとき"Platter OK"を表示します。NGのとき"Platter NG"を表示します。

3. エラーコードテーブル (ヒートランテスト、及び、チャッキングテストのとき表示されます)

エラーコード	内容
E100	サーボ自動調整エラー ディスクが検出できない。
E101	トラッキングオフセットが調整できない。
E103	フォーカスゲインが調整できない。
E104	フォーカスゲインが入らない。
E105	トラッキングサーボが入らない。
E106	トラッキングゲインが調整できない。
E202	サーボ自動調整中にサーボが外れた。
E300	TOCが規定時間内に読めない。
E400	ディスクが規定時間内にローディングできない。
E401	ディスクが規定時間内にイジェクトできない。
E500	スライドエラー

Detailed error can be displayed by PLATTER when error occurs

Error Indication				CHARACTER	
TR	MIN	SEC	FRAM	H *****	E *****
Displays the track No in which error occurred	Displays the time at which error occurred			↑ Operation count	↑ Error code

5. System μcom and DSP Version Upgrade

System μcom and DSP can be upgraded in the following manner

Version Upgrade Method

- Record the version upgrade software on a CD R or CD RW disc, only as one file with the format ISO9660 Mode 1. The file name of the supplied version upgrade software should be used as is and this disc needs to be finalized.
- After loading the disc made in above step 1, turn off the power. Then, turn on the power while pressing the NEXT TRACK button and FAST SEARCH FWD (▶▶) button. The version upgrade starts with reading data of the disc.
- When you start version upgrade operation, messages "Version Up" and "System&DSP" are displayed on the character display. Recovery positions are turned on one by one from the left end according as the upgrade operation proceeds. When this operation is completed, all recovery positions are turned on. In case of some error or the power is turned off during the version upgrade, it may be impossible to operate at all thereafter. Changing of IC502 on GU 3546 is necessary in this case, and software writing to IC502 should be done beforehand.
- When the upgrade is completed, the disk is ejected and operation returns to the normal mode.
- File name of the upgrade software indicates version numbers.

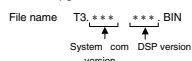

6. ROM Drive (FG-5000) μcom Version Upgrade

Drive (FG 5000) μcom can be upgraded in the following manner

Version Upgrade Method

- Record the version upgrade software on a CD R or CD RW disc, only as one file with the format ISO9660 Mode 1. The file name of the supplied version upgrade software should be used as is and this disc needs to be finalized.
- After turning on the power, load the disc made in above step 1 into the mecha you want to upgrade the version.
- "Drive" and "Version UP?" are indicated in the character display. Press the CD EJECT button and remove the disc when not upgrade the version.
- Press the PLAY/PAUSE to start the version upgrade. "Now Loading" is indicated.
- When the version upgrade is finished, "Complete" is indicated and the disc EJECT.
- Turn off the power once and turn on again after take out the disc. The version upgrade ends in 20~30 seconds normally. If the power turned off underway or the version upgrade ends abnormally, the drive may become malfunction. In such a case, version upgrade with PC will be needed.
- File name of the upgrade software indicates version number.



エラー表示				
トラック	分	秒	フレーム	キャラクター
エラーが発生したトラック番号	エラーが発生した時間 (Aタイム)			H***** 動作回数 E***** エラーコード

4. マイコンアップデート

DN-S5000 は、ディスクから、システムマイコン、DSP、CDドライブマイコンのアップデートを行うことができます。

(1) アップデートディスクの作成

システムマイコン、DSP、ドライブマイコンのアップデート用ディスクを作成するには下記に従って作成して下さい。

- アップデート用のディスクを、CD-R、又は CD-RW ディスクに ISO9660, MODE1 のフォーマットで記録し、ファイナライズする。
 - 配布されたアップデートファイルを、CDドライブソフトで DISC AT ONCE で書き込みしファイナライズする。
 - システムマイコン (DSP を含む) とドライブマイコンの2個のアップデートソフトを1枚のディスクに記録出来ます。その他のソフトやデータを同一ディスク内に記録しないこと。
 - ファイル名は、配布されたときのファイル名をそのまま使用すること。

(2) システムマイコン、DSP のアップデート

- (1) で作成したディスクをローディングし、電源を切り、NEXT TRACK と FAST SEARCH FWD (▶▶) ボタンを押しながら電源を入れると、ディスクのデータを読みとりアップデートを開始します。
- アップデートを開始すると、"Version Up"、"System & DSP" が表示されます。アップデートの進行に合わせて、再生位置表示が左から右へ順に点灯し、終了すると、全ての表示が点灯します。
注意 大変希ではありますが、アップデート中に、アップデート未終了の異常状態が発生することがあります。アップデートを開始し3分を経過しても終了しない場合も、異常が発生したと考えられますので、電源を切って、再度、(2) ①から同一の操作を行って下さい。
 発生した異常状況により、以後の全ての動作が出来なくなることがあります。その場合、GU-3546 IC502 の交換が必要になります。IC502 は、予め、ソフトウェアを書き込みする必要があります。(IC502 を発注の際は、最新のシステムマイコンバージョン No (GEN No) で発注願います。)
- アップデートが終了すると、ディスクがドライブ外れます。

(3) ドライブマイコンのアップデート

- システムマイコンのバージョンアップに引き続き、ドライブマイコンのバージョンアップを実施する場合は、再度、ディスクをローディングします。
 - ドライブマイコンのみバージョンアップする場合、電源投入後、(1) で作製したディスクを最初にローディングします。
- ドライブ用のアップデートソフトが認識されると、表示に **Drive Version UP?** が表示されます。
- PLAY/PAUSE ボタンを押すと、アップデートを開始し、**Now Loading** が表示されます。
- アップデートが終了すると、**Complete** が表示され、ディスクがドライブ外れます。
- 電源を切って終了です。
注意 大変希ではありますが、アップデート中に異常が発生することがあります。アップデートを開始し3分を経過しても終了しない場合も、異常が発生したと考えられますので、電源を切って、再投入して下さい。
 但し、アップデート開始から終了までの間に機器の電源を切った場合、又は異常が発生した場合、ドライブが動作しなくなることがあります。その場合、ハードウェアからのアップデートが必要になります。そのような場合は、QA に連絡願います。

SEMICONDUCTORS / 半導体一覧表

Only major semiconductors are shown, general semiconductors etc. are omitted to list.
 主な半導体を記載しています。汎用の半導体は記載を省略しています。

1. IC's

Note : Abbreviation ahead of IC No. indicates the name of P.W.B., etc.

注) : IC No. の前の記号は、基板の名称を表します。

DS : DSP P.W.B.

PA : PANEL P.W.B.

CD : CD-ROM P.W.B.

ADSP-21065L (DS: IC401)

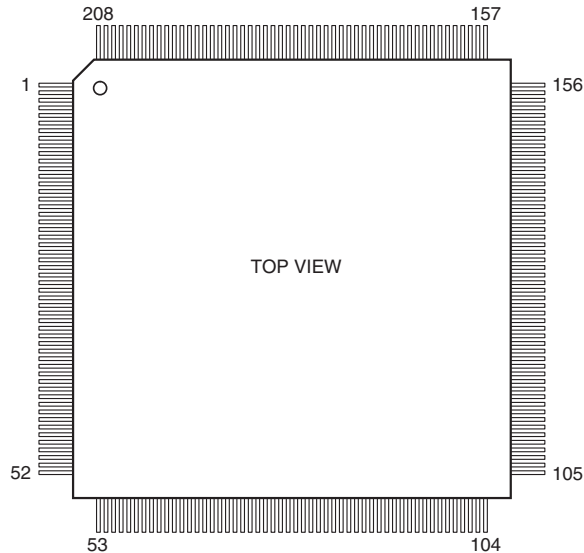

ADSP-21065L Terminal Function

Pin No.	Port Name	Symbol (IC301)	Symbol (IC401)	I/O	DET	Ext	Ini	Res	Function
1	VDD	VDD	VDD	—	—	—	—	—	Power (+3.3V)
2	RFS0	YLRCK	YLRCK	I	—	IPu	—	H	Receive frame sync (LRCK) signal (Serial port IN 0)
3	GND	GND	GND	—	—	—	—	—	GND
4	RCLK0	YBCK	YBCK	I	—	—	—	—	Receive frame sync (BCK) signal (Serial port IN 0)
5	DR0A	ADDATA	ADDATA	I	—	IPu	—	H	Data receive A (serial port IN 0)
6	DR0B			I	—	IPu	—	H	Data receive B (serial port IN 0)
7	TFS0	YLRCK	YLRCK	I	—	IPu	—	H	Send frame sync (LRCK) signal (Serial port OUT 0)
8	TCLK0	YBCK	YBCK	I	—	—	—	—	Send frame sync (BCK) signal (Serial port OUT 0)
9	VDD	VDD	VDD	—	—	—	—	—	Power (+3.3V)
10	GND	GND	GND	—	—	—	—	—	GND
11	DT0A	MOUT1	MOUT2	O	—	IPu	—	H	Data send A (Serial port OUT 0)
12	DT0B	DOUT1	DOUT2	O	—	IPu	—	H	Data send B (Serial port OUT 0)
13	RFS1	LRCK1	LRCK2	I	—	IPu	—	H	Receive frame sync (LRCK) signal (Serial port IN 1)
14	GND	GND	GND	—	—	—	—	—	GND
15	RCLK1	BCK1	BCK2	I	—	—	L	—	Receive frame sync (BCK) signal (Serial port IN 1)
16	DR1A	SAMP2	SAMP1	I	—	IPu	—	H	Data receive A (serial port IN 1)
17	DR1B			I	—	IPu	—	H	Data receive B (serial port IN 1)
18	TFS1	LRCK2	LRCK1	I/O	—	IPu	—	H	Send frame sync (LRCK) signal (Serial port OUT 1)
19	TCLK1	BCK2	BCK1	I/O	—	—	—	—	Send frame sync (BCK) signal (Serial port OUT 1)
20	VDD	VDD	VDD	—	—	—	—	—	Power (+3.3V)
21	VDD	VDD	VDD	—	—	—	—	—	Power (+3.3V)
22	DT1A	SOUT1	SOUT2	O	—	IPu	—	H	Data send A (Serial port OUT 1)
23	DT1B	SAMP1	SAMP2	O	—	IPu	—	H	Data send B (Serial port OUT 1)
24	PWM_EVENT1			I/O	—	Pd	—	L	PWM1 output
25	GND	GND	GND	—	—	—	—	—	GND
26	PWM_EVENT0			I/O	—	Pd	—	L	PWM0 output
27	BR1_			I	—	Pu	—	H	Multi-processing bus request 1
28	BR2_			I	—	Pu	—	H	Multi-processing bus request 1
29	VDD	VDD	VDD	—	—	—	—	—	Power (+3.3V)
30	CLKIN			I	—	—	—	—	Clock input
31	XTAL_			O	—	—	—	—	X'tal oscillator pin
32	VDD	VDD	VDD	—	—	—	—	—	Power (+3.3V)

Pin No.	Port Name	Symbol (IC301)	Symbol (IC401)	I/O	DET	Ext	Ini	Res	Function
33	GND	GND	GND	—	—	—	—	—	GND
34	SDCLK1			O	—	Pd	—	L	SDRAM clock enable 1
35	GND	GND	GND	—	—	—	—	—	GND
36	VDD	VDD	VDD	—	—	—	—	—	Power (+3.3V)
37	SDCLK0			I/O	—	—	—	—	SDRAM clock enable 0
38	DMAR1_			I	—	Pu	H	H	DMA request 1
39	DMAR2_			I	—	Pu	H	H	DMA request 2
40	HBR_			I	—	Pu	—	H	Host bus request (BOOT)
41	GND	GND	GND	—	—	—	—	—	GND
42	RAS_			I/O	—	Pu	H	H	SDRAM row access strobe
43	CAS_			I/O	—	Pu	H	H	SDRAM column access strobe
44	SDWE_			I/O	—	Pu	H	H	SDRAM write enable
45	VDD	VDD	VDD	—	—	—	—	—	Power (+3.3V)
46	DQM			O	—	—	—	—	SDRAM data mask
47	SDCKE			I/O	—	—	H	—	SDRAM clock enable
48	SDA10			O	—	Pd	L	L	SDRAM A10
49	GND	GND	GND	—	—	—	—	—	GND
50	DMAG1_			O	—	—	H	—	DMA ground 1
51	DMAG2_			O	—	—	H	—	DMA ground 2
52	HBG_			O	—	—	H	—	Host bus ground (BOOT)
53	BMSTR			O	—	—	H	—	Bus master output (H out)
54	VDD	VDD	VDD	—	—	—	—	—	Power (+3.3V)
55	CS_			I	—	—	L	L	Chip select (BOOT)
56	SBTS_			I	—	Pu	H	H	Extend bus three state
57	GND	GND	GND	—	—	—	—	—	GND
58	WR_			I/O	—	—	—	—	Memory write strobe
59	RD_			I/O	—	—	—	—	Memory read strobe
60	GND	GND	GND	—	—	—	—	—	GND
61	VDD	VDD	VDD	—	—	—	—	—	Power (+3.3V)
62	GND	GND	GND	—	—	—	—	—	GND
63	REDY			O	—	—	—	—	Host bus ACK
64	SW_			I/O	—	—	—	—	Sync type write select
65	CPA_			I/O	—	—	—	—	Core priority access
66	VDD	VDD	VDD	—	—	—	—	—	Power (+3.3V)
67	VDD	VDD	VDD	—	—	—	—	—	Power (+3.3V)
68	GND	GND	GND	—	—	—	—	—	GND
69	ACK			I/O	—	—	—	—	Memory ACK
70	MS0_			I/O	—	Pu	H	H	Memory select 0
71	MS1_			I/O	—	—	—	—	Memory select 1
72	GND	GND	GND	—	—	—	—	—	GND
73	GND	GND	GND	—	—	—	—	—	GND
74	MS2_			I/O	—	—	—	—	Memory select 2
75	MS3_			I/O	—	—	—	—	Memory select 3
76	FLAG11	DMABSY1	DMABSY2	O	—	Pu	—	H	General flag 11 (In DMA flag L: DMA)
77	VDD	VDD	VDD	—	—	—	—	—	Power (+3.3V)
78	FLAG10	SAMP COP	SAMP COPY	I/O	—	Pu	—	H	General flag 10 (In SAMPLER copy flag)
79	FLAG9	JOGB1	JOGB2	I	—	—	—	—	General flag 9 (JOG turning direction detect signal B)
80	FLAG8	JOGA1	JOGA2	I	—	—	—	—	General flag 8 (JOG turning direction detect signal A)
81	GND	GND	GND	—	—	—	—	—	GND
82	DATA0			I/O	—	—	—	—	Ext. bus data 0
83	DATA1			I/O	—	—	—	—	Ext. bus data 1
84	DATA2			I/O	—	—	—	—	Ext. bus data 2
85	VDD	VDD	VDD	—	—	—	—	—	Power (+3.3V)
86	DATA3			I/O	—	—	—	—	Ext. bus data 3
87	DATA4			I/O	—	—	—	—	Ext. bus data 4
88	DATA5			I/O	—	—	—	—	Ext. bus data 5
89	GND	GND	GND	—	—	—	—	—	GND
90	DATA6			I/O	—	—	—	—	Ext. bus data 6
91	DATA7			I/O	—	—	—	—	Ext. bus data 7
92	DATA8			I/O	—	—	—	—	Ext. bus data 8
93	VDD	VDD	VDD	—	—	—	—	—	Power (+3.3V)
94	GND	GND	GND	—	—	—	—	—	GND

Pin No.	Port Name	Symbol (IC301)	Symbol (IC401)	I/O	DET	Ext	Ini	Res	Function
95	VDD	VDD	VDD	—	—	—	—	—	Power (+3.3V)
96	DATA9			I/O	—	—	—	—	Ext. bus data 9
97	DATA10			I/O	—	—	—	—	Ext. bus data 10
98	DATA11			I/O	—	—	—	—	Ext. bus data 11
99	GND	GND	GND	—	—	—	—	—	GND
100	DATA12			I/O	—	—	—	—	Ext. bus data 12
101	DATA13			I/O	—	—	—	—	Ext. bus data 13
102	NC			—	—	—	—	—	NC
103	NC			—	—	—	—	—	NC
104	DATA14			I/O	—	—	—	—	Ext. bus data 14
105	VDD	VDD	VDD	—	—	—	—	—	Power (+3.3V)
106	GND	GND	GND	—	—	—	—	—	GND
107	DATA15			I/O	—	—	—	—	Ext. bus data 15
108	DATA16			I/O	—	—	—	—	Ext. bus data 16
109	DATA17			I/O	—	—	—	—	Ext. bus data 17
110	VDD	VDD	VDD	—	—	—	—	—	Power (+3.3V)
111	DATA18			I/O	—	—	—	—	Ext. bus data 18
112	DATA19			I/O	—	—	—	—	Ext. bus data 19
113	DATA20			I/O	—	—	—	—	Ext. bus data 20
114	GND	GND	GND	—	—	—	—	—	GND
115	NC			—	—	—	—	—	NC
116	DATA21			I/O	—	—	—	—	Ext. bus data 21
117	DATA22			I/O	—	—	—	—	Ext. bus data 22
118	DATA23			I/O	—	—	—	—	Ext. bus data 23
119	GND	GND	GND	—	—	—	—	—	GND
120	VDD	VDD	VDD	—	—	—	—	—	Power (+3.3V)
121	DATA24			I/O	—	—	—	—	Ext. bus data 24
122	DATA25			I/O	—	—	—	—	Ext. bus data 25
123	DATA26			I/O	—	—	—	—	Ext. bus data 26
124	VDD	VDD	VDD	—	—	—	—	—	Power (+3.3V)
125	GND	GND	GND	—	—	—	—	—	GND
126	DATA27			I/O	—	—	—	—	Ext. bus data 27
127	DATA28			I/O	—	—	—	—	Ext. bus data 28
128	DATA29			I/O	—	—	—	—	Ext. bus data 29
129	GND	GND	GND	—	—	—	—	—	GND
130	VDD	VDD	VDD	—	—	—	—	—	Power (+3.3V)
131	VDD	VDD	VDD	—	—	—	—	—	Power (+3.3V)
132	DATA30			I/O	—	—	—	—	Ext. bus data 30
133	DATA31			I/O	—	—	—	—	Ext. bus data 31
134	FLAG7	DFLG12	DFLG22	I/O	—	Pu	—	H	General flag 7 (RESERVE)
135	GND	GND	GND	—	—	—	—	—	GND
136	FLAG6	DFLG11	DFLG21	I/O	—	Pu	—	H	General flag 6 (RESERVE)
137	FLAG5	DTIMB1	DTIMB2	O	—	—	—	—	General flag 5 (Pulse output for generating monitor play time)
138	FLAG4	DTIMA1	DTIMA2	O	—	—	—	—	General flag 4 (Pulse output for generating main play time)
139	GND	GND	GND	—	—	—	—	—	GND
140	VDD	VDD	VDD	—	—	—	—	—	Power (+3.3V)
141	VDD	VDD	VDD	—	—	—	—	—	Power (+3.3V)
142	NC			—	—	—	—	—	NC
143	ID1			I	—	—	L	L	Multi-processing ID1 (Single processor: 0)
144	ID0			I	—	—	L	L	Multi-processing ID2 (Single processor: 0)
145	EMU_	EMU1_	EMU2_	O	—	—	—	—	Emulation status
146	TD0	TD01	TD02	O	—	—	—	—	Test data output (JTAG)
147	TRST_	TRST1_	TRST2_	I	—	IPu	—	H	Test reset (JTAG)
148	TDI	TDI1	TDI2	I	—	Pd	—	L	Test data input (JTAG)
149	TMS	TMS1	TMS2	I	—	IPu	—	H	Test mode select (JTAG)
150	GND	GND	GND	—	—	—	—	—	GND
151	TCK	TCK1	TCK2	I	—	Pu	—	H	Test clock (JTAG)
152	BSEL			I	—	—	H	H	EPROM boot select (Boot by EPROM: 1)
153	BMS_	BMS1_	BMS2_	I	—	—	H	H	Boot memory select (Host processor boot: 1)
154	GND	GND	GND	—	—	—	—	—	GND
155	GND	GND	GND	—	—	—	—	—	GND
156	VDD	VDD	VDD	—	—	—	—	—	Power (+3.3V)

Pin No.	Port Name	Symbol (IC301)	Symbol (IC401)	I/O	DET	Ext	Ini	Res	Function
157	RESET_	DRES_	DRES_	I	—	—	H	L	DSP reset signal
158	VDD	VDD	VDD	—	—	—	—	—	Power (+3.3V)
159	GND	GND	GND	—	—	—	—	—	GND
160	ADDR23			I/O	—	—	—	—	Ext. bus address 23
161	ADDR22			I/O	—	—	—	—	Ext. bus address 22
162	ADDR21			I/O	—	—	—	—	Ext. bus address 21
163	VDD	VDD	VDD	—	—	—	—	—	Power (+3.3V)
164	ADDR20			I/O	—	—	—	—	Ext. bus address 20
165	ADDR19			I/O	—	—	—	—	Ext. bus address 19
166	ADDR18			I/O	—	—	—	—	Ext. bus address 18
167	GND	GND	GND	—	—	—	—	—	GND
168	GND	GND	GND	—	—	—	—	—	GND
169	ADDR17			I/O	—	—	—	—	Ext. bus address 17
170	ADDR16			I/O	—	—	—	—	Ext. bus address 16
171	ADDR15			I/O	—	—	—	—	Ext. bus address 15
172	VDD	VDD	VDD	—	—	—	—	—	Power (+3.3V)
173	ADDR14			I/O	—	—	—	—	Ext. bus address 14
174	ADDR13			I/O	—	—	—	—	Ext. bus address 13
175	ADDR12			I/O	—	—	—	—	Ext. bus address 12
176	VDD	VDD	VDD	—	—	—	—	—	Power (+3.3V)
177	GND	GND	GND	—	—	—	—	—	GND
178	ADDR11			I/O	—	—	—	—	Ext. bus address 11
179	ADDR10			I/O	—	—	—	—	Ext. bus address 10 (SDRAM: Connects SDA10)
180	ADDR9			I/O	—	—	—	—	Ext. bus address 9
181	GND	GND	GND	—	—	—	—	—	GND
182	VDD	VDD	VDD	—	—	—	—	—	Power (+3.3V)
183	ADDR8			I/O	—	—	—	—	Ext. bus address 8
184	ADDR7			I/O	—	—	—	—	Ext. bus address 7
185	ADDR6			I/O	—	—	—	—	Ext. bus address 6
186	GND	GND	GND	—	—	—	—	—	GND
187	GND	GND	GND	—	—	—	—	—	GND
188	ADDR5			I/O	—	—	—	—	Ext. bus address 5
189	ADDR4			I/O	—	—	—	—	Ext. bus address 4
190	ADDR3			I/O	—	—	—	—	Ext. bus address 3
191	VDD	VDD	VDD	—	—	—	—	—	Power (+3.3V)
192	VDD	VDD	VDD	—	—	—	—	—	Power (+3.3V)
193	ADDR2			I/O	—	—	—	—	Ext. bus address 2
194	ADDR1			I/O	—	—	—	—	Ext. bus address 1
195	ADDR0			I/O	—	—	—	—	Ext. bus address 0
196	GND	GND	GND	—	—	—	—	—	GND
197	FLAG0	DR_W1	DR_W2	I/O	—	—	—	—	General flag 0 (Command read write select)
198	FLAG1	DACK1_	DACK2_	I/O	—	—	—	—	General flag 1
199	FLAG2	DBSY1	DBSY2	I/O	—	—	—	—	General flag 2
200	VDD	VDD	VDD	—	—	—	—	—	Power (+3.3V)
201	FLAG3	DFLG10	DFLG20	I/O	—	Pu	—	H	General flag 3 (RESERVE)
202	NC			—	—	—	—	—	—
203	NC			—	—	—	—	—	—
204	GND	GND	GND	—	—	—	—	—	GND
205	IRQ0_	DREQ1	DREQ2	I	—	Pu	—	H	Interrupt request input 0 (SYS mcom interface)
206	IRQ1_	DREQ1_	DREQ2_	I	—	Pu	—	L	Interrupt request input 1 (SYS mcom interface)
207	IRQ2_	JOGINT1	JOGINT2	I	—	—	—	—	Interrupt request input 2 (JOG turning speed detect signal)
208	NC			—	—	—	—	—	NC

M5705Q (CD: IC501)

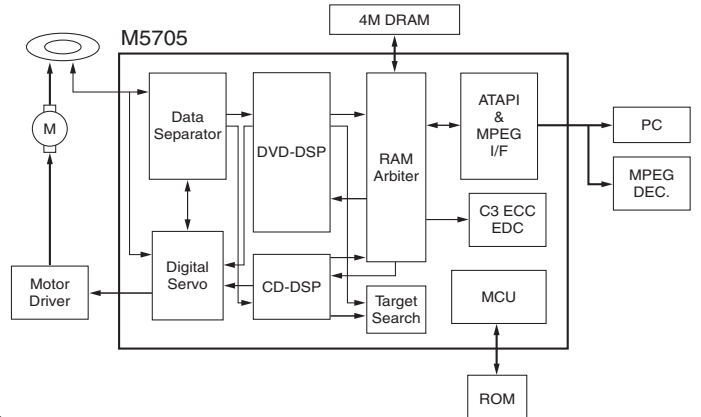
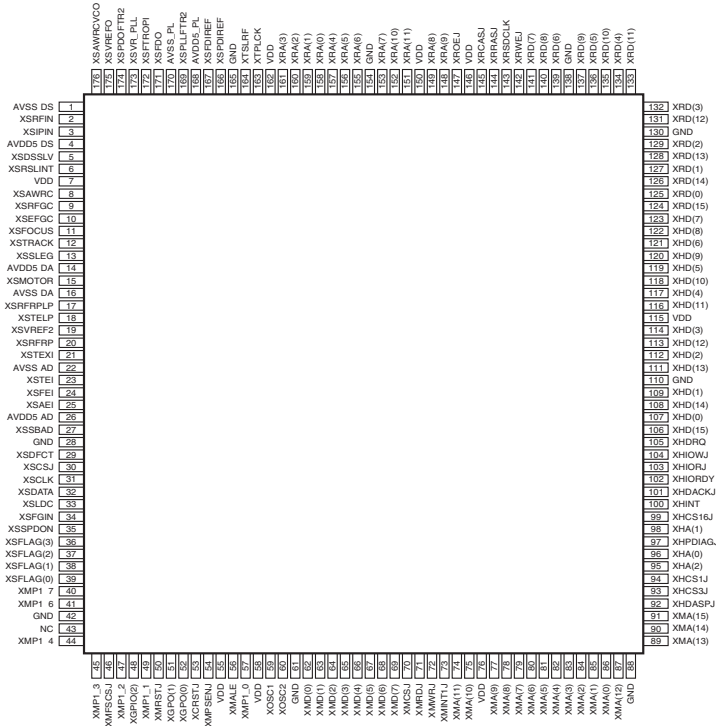

M5705 Terminal Function

Pin No.	Pin Name	Type	Description
2	XSRFIN	I/A	Analog RF signal input after passing through the equalizer
3	XSIPIN	I/A	Inverting input pin of data slicer
5	XSDSSLV	O/A	Slice level output pin
6	XSRSLINT	I/A	Reference current setting pin for analog data slicer
8	XSAWRC	O/A	Output for enlarge VCO range. Analog output from DAC buffer
9	XSRFGC	O/A	RF gain control output
10	XSEFGC	O/A	E,F gain control output
11	XSFOCUS	O/A	Output voltage level for focusing buffer IC
12	XSTRACK	O/A	Output voltage level for tracking buffer IC
13	XSSLEG	O/A	Output voltage level for sledge buffer IC
15	XSMOTOR	O/A	Output voltage level for spindle motor buffer IC
17	XSRFRPLP	I/A	High bandwidth low pass filter input for RFRP
18	XSTELP	I/A	High bandwidth low pass filter input for TE
19	XSVREF2	I/A	2.1V reference voltage input
20	XSRFRP	I/A	RF ripple/envelope signal input
21	XSTEXI	I/A	Tracking zero crossing input signal
23	XSTEI	I/A	Tracking error input signal
24	XSFEI	I/A	Focus error input signal
25	XSCEI	I/A	1. Center error input signal 2. Photo Interrupt input

Pin No.	Pin Name	Type	Description
27	XSSBAD	I/A	Sub beam addition signal input
166	XSPDIREF	I/A	Phase detector reference current generator. Connect a resistor between this pin and ground to set reference current
167	XSFDIRREF	I/A	Frequency detector reference current generator. Connect a resistor between this pin and ground to set reference current
169	XSPLLFTR2	I/A	Data PLL loop filter pin#2
171	XSFDO	O/A	Output node of frequency detector charge pump circuit
172	XSFTRPOI	I/A	Input node of loop filter OP circuit
173	XSVR_PLL	I/A	PLL reference voltage input
174	XSPDOFTR2	I/A	Phase detector filter pin#1
175	XSVREFO	O/A	Reference voltage output
176	XSAWRCVCO	I/A	Auto Wide Range Control of VCO input pin. For enlarge VCO range in CAV mode
29	XSDFACT	I	Detect detection signal input
30	XSCSJ	O	Chip select signal for accessing control registers
31	XSCLK	O	Clock output for accessing control registers
32	XSDATA	I/O	Registers data input/output pin
33	XSLDC	O	Laser diode on/off control output for both CD/DVD
34	XSFGIN	I	Motor Hall sensor input
35	XSSPDON	O	Spindle motor on output
36, 37, 38, 39	XSFLAG[3:0]	O	These pins are used to monitor some status of servo control block
48, 51, 52	XGPIO[2:0]	I/O	1. These pins are used as general purpose I/O bus 2. When use internal microcontroller, XGPIO[2] can be used as programmable I/O port 3.6.
40	XMP1_7	I/O	Internal microcontroller programmable I/O port 1.7.
41	XMP1_6	I/O	Internal microcontroller programmable I/O port 1.6.
43	XMP1_5	I/O	This pin is now changed to be NC.
44	XMP1_4	I/O	Internal microcontroller programmable I/O port 1.4.
45	XMP1_3	I/O	Internal microcontroller programmable I/O port 1.3.
47	XMP1_2	I/O	Internal microcontroller programmable I/O port 1.2.
49	XMP1_1	I/O	Internal microcontroller programmable I/O port 1.1.
57	XMP1_0	I/O	Internal microcontroller programmable I/O port 1.0. This pin is default used as the A16 (microcontroller address line 16)
46	XMFSCSJ	I/O	Output chip select connected to external flash ROM chip enable pin
54	XMPSENJ	I/O	Output program store enable connected to external ROM PSENJ pin.
56	XMALE	I/O	This signal is used as address latch signal in address/data mux mode
70	XMCSJ	I/O	1. This signal must be asserted for all microcontroller accesses to the register of this chip 2. When use internal microcontroller, this signal can be used as programmable I/O port 3.1
71	XMRDJ	I/O	1. This signal is used as the Read Strobe signal 2. When use internal microcontroller, this signal can be used as programmable I/O port 3.0
72	XMWRJ	I/O	This signal is used as the Wire Strobe signal
73	XMINT1J	I/O	1. This signal is an interrupt line to the microcontroller 2. When use internal microcontroller, this signal can be used as programmable I/O port 3.7
74, 75, 77, 78, 79, 80, 81, 82, 83, 84, 85, 86, 87, 89, 90, 91	XMA[15:0]	I/O	These pins are used as address bus
62, 63, 64, 65, 66, 67, 68, 69	XMD[7:0]	I/O	These pins are used as data bus for the 16 bit processor mode, or the address/data mux bus for the 8 bit processor mode.
163	XTPLCK	I/O	PLCK test pin
164	XTSLRF	I/O	SLRF test pin
59	XOSC1	I	Crystal input/System clock. The input frequency from outside crystal or oscillator is 33.8688MHz
60	XOSC2	O	Crystal output
53	XCRSTJ	I	Chip Reset. As asserted low input generates a component reset that stops all operations within the chip and deasserts all output signals. All input/output signals are set to input.
94	XHCS1J	I	This pin is used to select the command block task file registers
93	XHCS3J	I	This pin is used to select the control block task file registers
103	XHIORJ	I	Asserted by the host during a host I/O read operation
104	XHIOWJ	I	Asserted by the host during a host I/O write operation
105	XHDRQ	O	1. DMA request. This pin is configured as the DMA request signal, and is used during DMA transfer between the host and the controller. This pin is tri state when DMA transfers are not enabled. 2. MPEG acknowledge. This pin is used as the ACKJ signal when MPEG interface mode is selected.
101	XHDACKJ	I	1. DMA acknowledge. This pin is configured as DACKJ, and is used as the DMA acknowledge signal during DMA data transfers. 2. MPEG request. This pin is used as the REQ signal when MPEG interface mode is selected
99	XHCS16J	O	1. 16 bit data select. This signal indicates that a 16 bit data transfer is active on the host data bus. This pin is open drain tri state output. 2. MPEG clock. This pin is used as the CLOCK signal when MPEG interface mode is selected.
50	XHRSTJ	I	Host Reset. The reset of ATA bus
100	XHINT	O	1. Host interface request. This tri state pin is the host interrupt request, and is asserted to indicate to the host that the controller needs attention. 2. MPEG begin. This pin is used as the BEGIN signal when MPEG interface mode is selected

Pin No.	Pin Name	Type	Description
97	XHPDIAGJ	I/O	This pin is used as the Passed Diagnostics signal, and may be an input or an open drain output
92	XHDASPJ	I/O	This pin is used as the Drive Active/Slave Present signal, and is an input or an open drain output. This pin is used for Master/Slave drive communication and/or for driving an LED
102	XHIORDY	I/O	1. I/O channel ready. This signal is driven low to extend host transfer cycles when the controller is not ready to respond. This pin will be tri stated when a read or write is not in progress. 2. MPEG error. This pin is used as the ERROR signal when MPEG interface mode is selected
95, 96, 98	XHA[2:0]	I	Host address lines. The host address lines A[2:0] are used to access the various host control, status, and data registers
106, 107, 108, 109, 111, 112, 113, 114, 116, 117, 118, 119, 120, 121, 122, 123	XHD[15:0]	I/O	1. Host data bus. This bus is used to transfer data and status between the host and the controller. 2. MPEG data bus 7 8. The HD[7:0] are used as the DATA [7:0] when MPEG interface mode is selected. 3. VCD I/F. Bit3 0 are used as VCD I/F signal when VCD function is enabled. The relationship of bit3 0 and VCD I/F is as follow HD0—CD DATA HD1—CD LRCK HD2—CD BCK HD3—CD C2PO
143	XRSDCLK	O	This signal is the clock output for SDRAM
147	XROEJ	O	This signal is used as the memory output enable for external DRAM buffers. After RSTJ is asserted, this signal will be low
142	XRWEJ	O	This signal is asserted low when a buffer memory write operation is active
144	XRRASJ	O	This signal is used as Row address output to external DRAM buffer. After RSTJ is asserted, this signal will be high
145	XRCASJ	O	This signal is used as column address output to external DRAM. After RSTJ is asserted, this signal will be high
148, 149, 151, 152, 153, 155, 156, 157, 158, 159, 160, 161	XRA[11:0]	O	1. RAM address lines. These are bits11 0 for addressing the buffer memory. 2. Hardware setting. The bits6 0 are used as hardware setting for some functions. RA[9] : FLASH size is 64K/128K 1: FLASH size is 64K 0: FLASH size is 128K RA[8] : External CPU is 8032/H8 1: 8032 0: H8 RA[7] : Microcontroller programmable I/O port 1 pin control 1: By internal microcontroller 0: By registers to decide input/output RA[6] : System test pin output 1: Normal operation 0: System test pin output RA[5] : For testing purpose, donit need to set RA[4] : IDE master/slave 1: Slave 0: Master RA[3] : For testing purpose, donit need to set RA[2] : For testing purpose, donit need to set RA[1 0] : MCU Mode selection 11: Normal Mode (internal uP, internal address latch) 10: Outside uP Mode (ICE Mode) 01: Test mode for internal uP testing 00: Internal uP mode with external address latch
124, 125, 126, 127, 128, 129, 131, 132, 134, 135, 136, 137, 138, 139, 140, 141	XRD[15:0]	I/O	These signals are the 8 bit parallel data lines to/from the buffer memory.
4	AVDD5_DS		Analog Power +5V for Data Slicer part
14	AVDD5_DA		Analog Power +5V for DAC part
26	AVDD5_AD		Analog Power +5V for ADC part
168	AVDD5_PL		Analog Power +5V for Data PLL part
7, 55, 58, 76, 115, 146, 150, 162	VDD		Power +3.3V for digital core logic and pad
1	AVSS_DS		Analog Ground for Data Slicer part
16	AVSS_DA		Analog Ground for DAC part
22	AVSS_AD		Analog Ground for ADC part
170	AVSS_PL		Analog Ground for Data PLL part
28, 42, 61, 88, 110, 130, 138, 154, 165	GND		Digital Ground core logic and pad.

MN102H730F (DS: IC501)

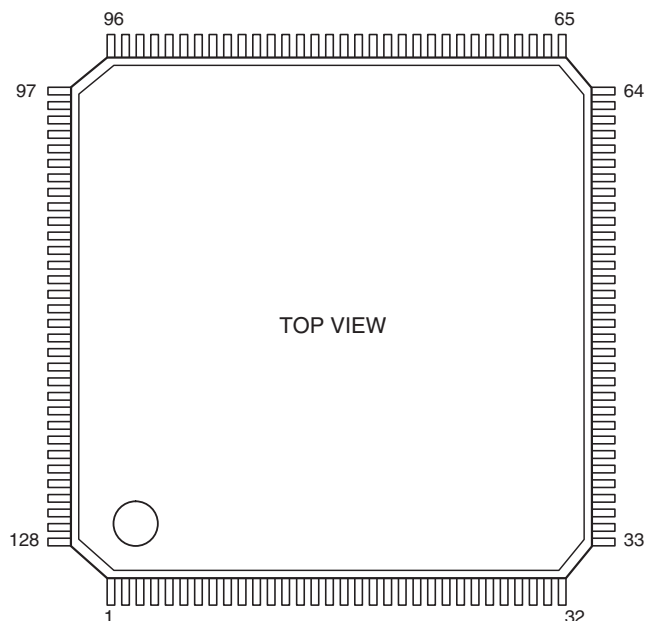

MN102H730F Terminal Function

Pin No.	Pin Name	Symbol	I/O	DET	Ext	Ini	Res	Function
1	CS0_	CS0_	O	—	Pu	—	—	Ext. memory chip select 0 (Flash ROM CS)
2	CS1_	CS1_	O	—	Pu	—	—	Ext. memory chip select 1 (Flash ROM for memo)
3	D00	DQ0	I/O	—	—	—	—	Ext. memory data in/output 0, DSP interface 0
4	D01	DQ1	I/O	—	—	—	—	Ext. memory data in/output 1, DSP interface 1
5	D02	DQ2	I/O	—	—	—	—	Ext. memory data in/output 2, DSP interface 2
6	D03	DQ3	I/O	—	—	—	—	Ext. memory data in/output 3, DSP interface 3
7	VDD	VDD	—	—	—	—	—	Power (+3.3V)
8	VSS	VSS	—	—	—	—	—	GND
9	D04	DQ4	I/O	—	—	—	—	Ext. memory data in/output 4, DSP interface 4
10	D05	DQ5	I/O	—	—	—	—	Ext. memory data in/output 5, DSP interface 5
11	D06	DQ6	I/O	—	—	—	—	Ext. memory data in/output 6, DSP interface 6
12	D07	DQ7	I/O	—	—	—	—	Ext. memory data in/output 7, DSP interface 7
13	D08	DQ8	I/O	—	—	—	—	Ext. memory data in/output 8, DSP interface 8
14	D09	DQ9	I/O	—	—	—	—	Ext. memory data in/output 9, DSP interface 9
15	D10	DQ10	I/O	—	—	—	—	Ext. memory data in/output 10, DSP interface 10
16	PD0,DMAACK1_	RESERVE	O	—	—	L	—	
17	PD1,DMAREQ1_	RESERVE	O	—	—	L	—	
18	D11	DQ11	I/O	—	—	—	—	Ext. memory data in/output 11, DSP interface 11
19	D12	DQ12	I/O	—	—	—	—	Ext. memory data in/output 12, DSP interface 12
20	D13	DQ13	I/O	—	—	—	—	Ext. memory data in/output 13, DSP interface 13
21	D14	DQ14	I/O	—	—	—	—	Ext. memory data in/output 14, DSP interface 14
22	D15	DQ15	I/O	—	—	—	—	Ext. memory data in/output 15, DSP interface 15
23	WORD	WORD	I	—	—	—	—	Data bus width select (H: 16bit),GND fixed
24	VDD	VDD	—	—	—	—	—	Power (+3.3V)
25	MODE	MODE	I	—	—	L	L	Processor mode, GND fixed

Pin No.	Pin Name	Symbol	I/O	DET	Ext	Ini	Res	Function
26	PC3	MUTE	O	—	Pu	H	H	Mute signal (H: Mute)
27	XI	XI	I	—	—	—	—	Oscillation input
28	XO	XO	O	—	—	—	—	Oscillation output
29	VDD	VDD	—	—	—	—	—	Power (+3.3V)
30	OSCI	OSCI	I	—	—	—	—	Oscillation input, 32.0MHz
31	OSCO	OSCO	O	—	—	—	—	Oscillation output
32	VSS	VSS	—	—	—	—	—	GND
33	P57,BOSC	TEST	I	—	—	—	—	32.0MHz output
34	PC5,NMI	NMI	I	—	—	—	—	Connect to Power
35	RST_	RST_	I	—	—	—	—	µcom reset
36	PC0	YMCLK	O	—	—	H	—	Clock for AK4353 data
37	P76	TEST	O	—	Pu	—	—	P.W.B. check mode IN
38	P60,IRQ0	DTIMA	I	—	Pu	H	H	Main playback clock input
39	P61,IRQ1	DTIMB	I	—	Pu	H	H	Monitor playback clock input
40	P62,IRQ2,TM10IOA	TABLE	I	—	(Pu)	H	H	Clock pulse input for platter
41	P63,IRQ3,TM10IOA	CLK4M	I	—	—	—	—	Clock pulse input for platter
42	P64,IRQ4	ATANS_	I	—	(Pu)	—	H	ATAPI µcom serial interface
43	P65,IRQ5,TM12IOA	DISCPA	I	—	(Pu)	H	H	Clock pulse input for scratch disc
44	P66,IRQ6	DISCDIR	I	—	(Pu)	H	H	Direction pulse input for scratch disc
45	P67,IRQ7	DISCINT	I	—	(Pu)	H	H	Start pulse input for scratch disc
46	P70,TM13IOB	DISCA	I	—	—	—	—	SCRATCH for DISC pulse A count input
47	P71	YMDATA	O	—	—	H	—	AK4353 output data
48	PD2,DMAACK0_	NRES_	O	—	Pd	L	L	AK4353 reset signal
49	PD3,TM3IO	DISCPA_	I	—	—	—	—	Clock invert pulse input for scratch disc
50	VDD	VDD	—	—	—	—	—	Power (+3.3V)
51	P77	RESERVE	O	—	—	L	—	
52	P72,TM14IOB	DISCPB	I	—	—	—	—	SCRATCH for DISC pulse B count input
53	P73	RESERVE	O	—	—	L	—	
54	P74	RESERVE	O	—	—	L	—	
55	P75,TM12IOB	CLK4M	I	—	—	—	—	Clock pulse input for disc
56	PA0,SBI0	RXD1	I	—	(Pu)	—	H	Data receive from PANEL
57	PA1,SBO0	TXD1	O	—	Pu	H	H	Data send to PANEL (PU µcom specify)
58	PA2,SBT0	MCMD_	O	—	Pu	H	H	ATAPI µcom serial interface (PU µcom specify)
59	PA3,SBI1	X'RXDOUT	I	—	(Pd)	—	H	Data receive from X'EFFECT OUT
60	PA4,SBO1	X'TXDOUT	O	—	Pu	H	H	Data send to X'EFFECT OUT
61	PA5	RESERVE	O	—	—	L	—	
62	PB0,SBI2	X'RXD IN	I	—	(Pd)	—	H	Data receive from X'EFFECT IN
63	PB1,SBO2	X'TXD IN	O	—	Pu	H	H	Data send to X'EFFECT IN
64	PB2	APRES_	O	—	Pd	L	L	ATAPI µcom reset signal
65	PB3,SBI3	ATDATA	I	—	(Pu)	—	H	ATAPI µcom serial receive signal
66	PB4,SBO3	MDATA	O	—	—	H	—	ATAPI µcom serial send signal
67	PB5,SBT3	MCLK	O	—	—	H	—	ATAPI µcom serial send/receive clock
68	VDD	VDD	—	—	—	—	—	Power (+3.3V)
69	VSS	VSS	—	—	—	—	—	GND
70	AVSS	AVSS	—	—	—	—	—	Analog ref. GND for A/D conversion, GND
71	Vref	Vref	—	—	—	—	—	Analog ref. V for A/D conversion, GND
72	P80	DFLG2	I/O	—	Pu	—	H	DSP general flag 2
73	P81	DFLG1	I/O	—	Pu	—	H	DSP general flag 1
74	P82	DR_/W1	O	—	—	H	—	DSP interface send/receive select signal
75	P83	DACK_	I	—	Pu	H	H	DSP interface ACK
76	P84	DBSY_	I	—	Pu	H	H	DSP interface busy signal
77	P85	DFLG0	I/O	—	Pu	—	H	DSP general flag 0
78	P86	DREQ_	O	—	Pu	H	H	DSP interface request signal
79	P87	FPLAY1	I	—	(Pu)	H	H	Main fader start PLAY input
80	PD4	FCUE1	I	—	(Pu)	H	H	Main fader start CUE input
81	PD5	TESTIN1	I	—	Pu	—	H	
82	P90	TESTIN2	I	—	Pu	—	H	
83	P91	RESERVE	O	—	—	L	—	
84	P92	PNLRST	—	—	Pd	L	L	Panel µcom reset signal (L:Reset)
85	P93	APOWER	O	—	Pd	L	L	Analog output voltage ON/OFF (L:OFF)
86	Vref+	Vref+	—	—	—	—	—	Analog ref. V for A/D conversion, +3.3V
87	AVDD	AVDD	—	—	—	—	—	Power (+3.3V)

Pin No.	Pin Name	Symbol	I/O	DET	Ext	Ini	Res	Function
88	P94	MCNT0	O	—	Pu	L	L	Motor control signal 0
89	P95	MCNT1	O	—	Pu	L	L	Motor control signal 1
90	P96,DAC2	MCNTDA	O	—	Pu	L	L	Motor rotation speed control signal A/D 0
91	P97,DAC3	RESERVE	O	—	—	H	—	
92	BREQ_	BREQ_	I	—	(Pu)	H	H	Bus request signal
93	BRACK_	BRACK_	O	—	Pu	H	H	Bus request accept signal
94	WEL_	WE_	O	—	Pu	—	H	Ext. memory write enable (Lower 8bit)
95	P51	RESERVE	O	—	—	H	—	
96	RE_	RE_	O	—	Pu	—	H	Ext. memory read enable
97	CS2_	CS2_	O	—	Pu	—	H	Ext. memory chip select 2 (DSP1 interface)
98	VDD	VDD	—	—	—	—	—	Power (+3.3V)
99	VSS	VSS	—	—	—	—	—	GND
100	P54, BSTRE	ML	O	—	—	H	—	AK4353 chip select
101	P55, WR_	RESERVE	O	—	—	H	—	
102	CS3_	CS3_	O	—	—	—	—	Not used
103	A00	A00	O	—	—	—	—	Ext. memory address bus 0
104	A01	A01	O	—	—	—	—	Ext. memory address bus 1
105	A02	A02	O	—	—	—	—	Ext. memory address bus 2
106	A03	A03	O	—	—	—	—	Ext. memory address bus 3
107	A04	A04	O	—	—	—	—	Ext. memory address bus 4
108	A05	A05	O	—	—	—	—	Ext. memory address bus 5
109	A06	A06	O	—	—	—	—	Ext. memory address bus 6
110	A07	A07	O	—	—	—	—	Ext. memory address bus 7
111	A08	A08	O	—	—	—	—	Ext. memory address bus 8
112	PD6	RESERVE	O	—	—	L	—	
113	PD7, TM7IO	DISCPB_	I	—	—	—	—	
114	A09	A09	O	—	—	—	—	Ext. memory address bus 9
115	A10	A10	O	—	—	—	—	Ext. memory address bus 10
116	A11	A11	O	—	—	—	—	Ext. memory address bus 11
117	A12	A12	O	—	—	—	—	Ext. memory address bus 12
118	A13	A13	O	—	—	—	—	Ext. memory address bus 13
119	VDD	VDD	—	—	—	—	—	Power (+3.3V)
120	PC4	RESERVE	O	—	—	L	—	
121	A14	A14	O	—	—	—	—	Ext. memory address bus 14
122	A15	A15	O	—	—	—	—	Ext. memory address bus 15
123	A16	A16	O	—	—	—	—	Ext. memory address bus 16
124	A17	A17	O	—	Pu	—	—	Ext. memory address bus 17
125	A18	A18	O	—	Pu	—	—	Ext. memory address bus 18
126	A19	A19	O	—	Pu	—	—	Ext. memory address bus 19
127	A20	A20	O	—	Pu	—	—	Ext. memory address bus 20
128	A21	A21	O	—	Pu	—	—	Ext. memory address bus 21

128M-SDRAM (DS: IC402)

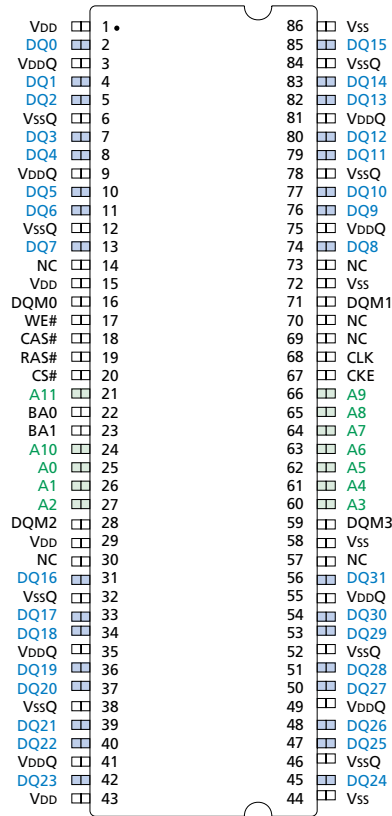

Note: The # symbol indicates signal is active LOW.

Block Diagram

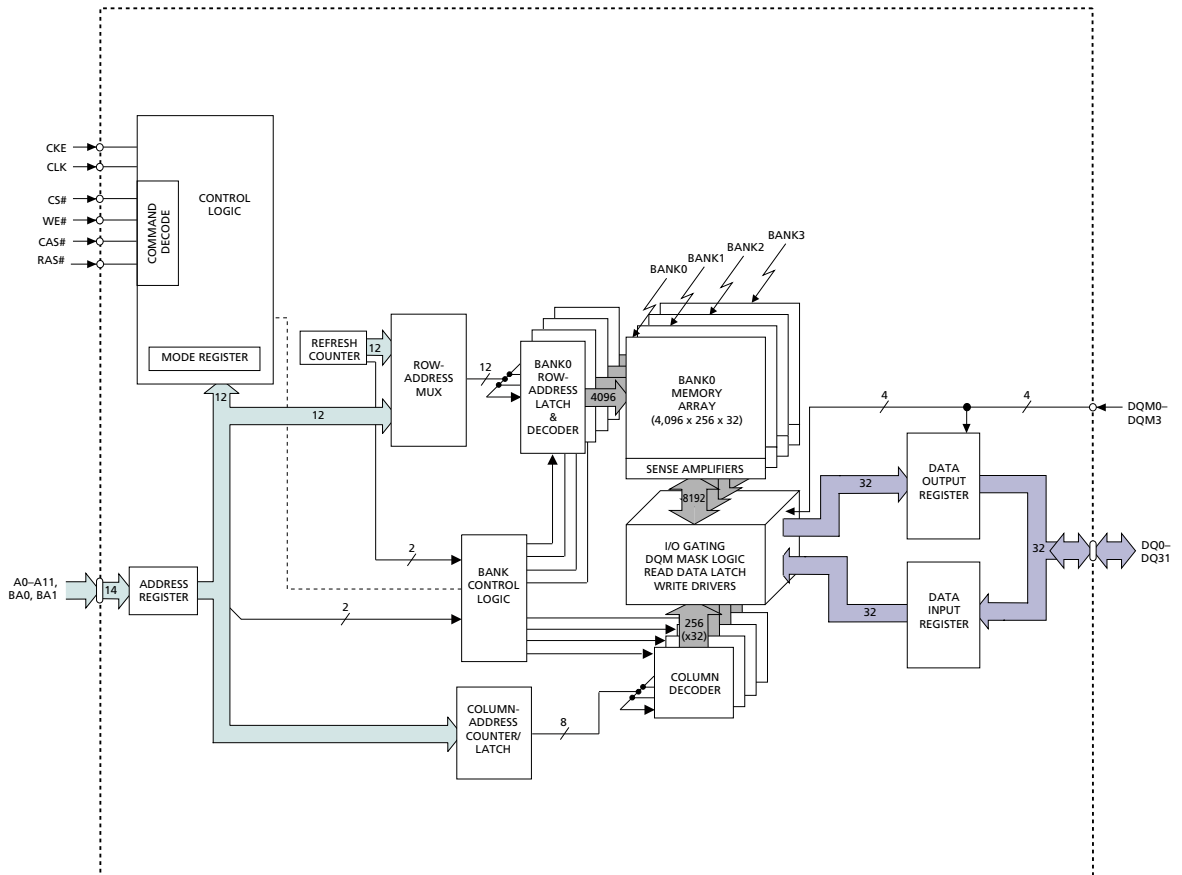

128M-SDRAM Terminal Function

Pin NO.	Symbol	Type	Description
68	CLK	I	Clock
67	CKE	I	Clock Enable
20	CS#	I	Chip Select
17, 18, 19	WE#, CAS#, RAS#	I	Command Inputs
16, 71, 28, 59	DQM0 DQM3	I	Input/Output Mask
22, 23	BA0, BA1	I	Bank Address Input(s)
21, 24 27, 60 66	A0 A11	I	Address Inputs
2, 4, 5, 7, 8, 10, 11, 13, 31, 33, 34, 36, 37, 39, 40, 42, 45, 47, 48, 50, 51, 53, 54, 56, 74, 76, 77, 79, 80, 82, 83, 85	DQ0 DQ31	I/O	Data I/Os
14, 30, 57, 69, 70, 73	NC		No Connect
3, 9, 35, 41, 49, 55, 75, 81	V _{DDQ}	Supply	DQ Power Supply
6, 12, 32, 38, 46, 52, 78, 84	V _{SSQ}	Supply	DQ Ground
1, 15, 29, 43	V _{DD}	Supply	Power Supply: +3.3V ±0.3V
44, 58, 72, 86	V _{SS}	Supply	Ground

ML9207-01GP (PA: IC101)

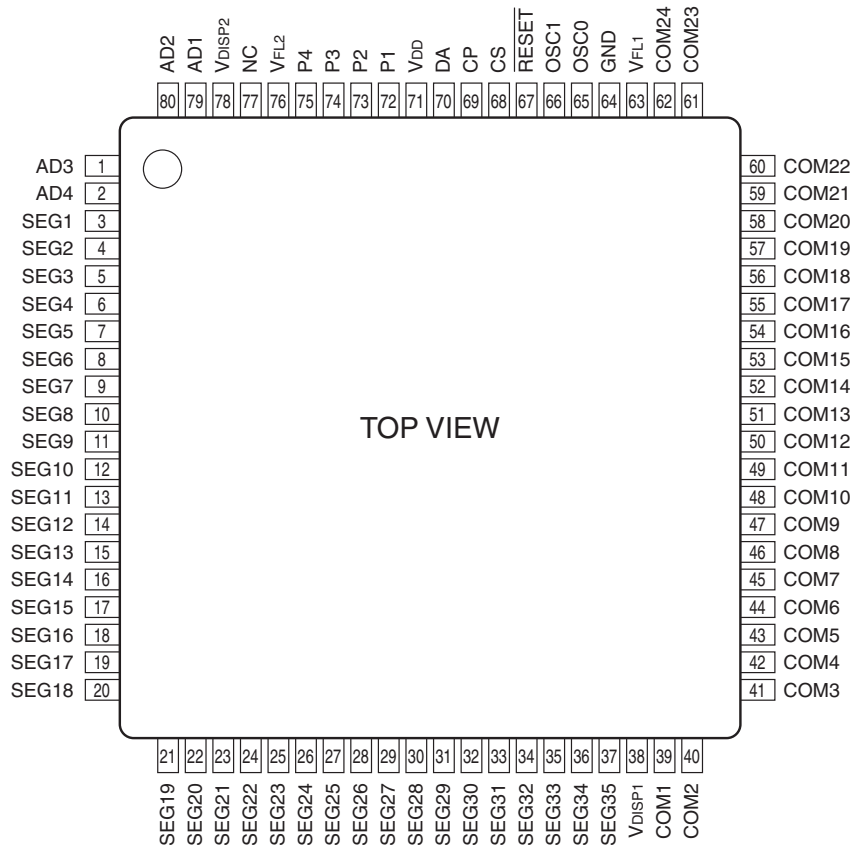

ML9207-01GP Terminal Function

Pin No.	Symbol	I/O	Function
3-37	SEG1-35	O	FL display anode electrode drive output pin
39-62	COM1-24	O	FL display grid electrode drive output pin
1, 2, 79, 80	AD1~4	O	FL display anode electrode drive output pin
72~75	P1~4	O	General port output pin
71	VDD	—	VDD-GND: Power for logic VDISP-VFL: Power for FL display drive Same power source should be used for VDD and VDISP
38, 78	VDISP1-2		
64	GND		
63, 76	VFL1-2		
70	DA	I	Serial data input pin (positive logic).
69	CP	I	Shift clock input pin
68	CS	I	Chip select input pin
67	RESET	I	Reset input pin, L: All functions are initialized
65	OSCO	I	Pin for self-oscillation, target oscillation frequency 4.0MHz
66	OSC1	O	
77	NC	—	Not used

SP-3721A (CD: IC502)

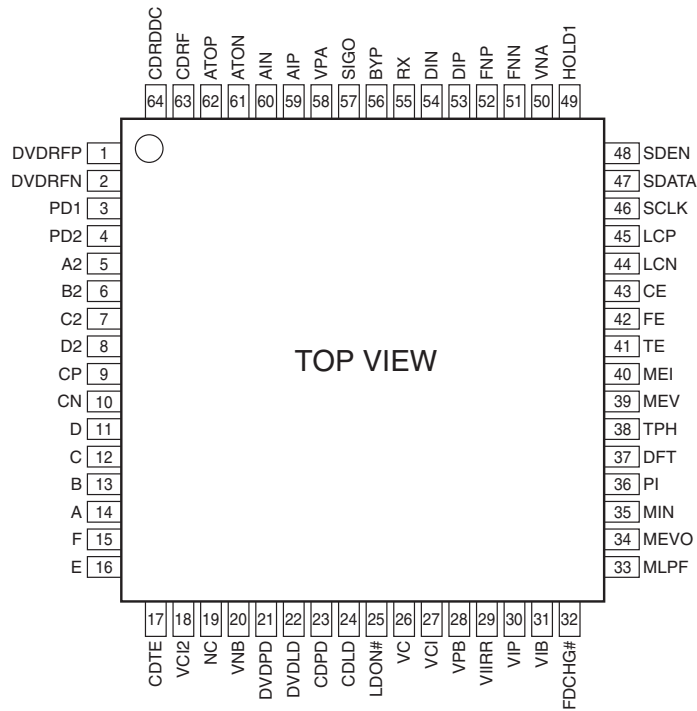

SP3721A Terminal Function

Pin No.	Pin Name	Type	Description
1, 2	DVDREP, DVDREN	I	RF Signal Inputs. Differential RF signal attenuator input pins
63	CDRF	I	RF Signal Inputs. Single ended RF signal attenuator input pin
59, 60	AIP, AIN	I	AGC Amplifier Inputs. Differential AGC amplifier input pins
53, 54	DIP, DIN	I	Analog inputs for RF Single Buffer. Differential analog inputs to the RF single ended output buffer and full wave rectifier
32	FDCHG#	I	Low Impedance Enable. A TTL compatible input pin that activates the FDCHG switches. A low level activates the switches and the falling edge of the internal FDCHG triggers the fast decay for the MIRR bottom hold circuit. (open high)
49	HOLD1	I	Hold Control. A TTL compatible control pin which, when pulled high, disables the RF AGC charge pump and holds the RF AGC amplifier gain at its present value. (open high)
11~14	D, C, B, A	I	Photo Detector Interface Inputs. Inputs from the main beam Photo detector matrix outputs
5~8	A2, B2, C2, D2	I	Photo Detector Interface Inputs. AC coupled inputs for the DPD from the main beam Photo detector matrix outputs
15~16	F, E	I	CD tracking Error Inputs. Inputs from the CD photo detector error outputs.
3~4	PD1, PD2	I	CD Photo detector Interface Inputs. Inputs from the CD photo detector error outputs
40	MEI	I	Mirror Envelope Inputs. The SIGO envelope input pin
35	MIN	I	RF signal Input for Mirror. AC coupled inputs for the mirror detection circuit from the pull in signal output. (PI)
21	DVDPD	I	APC Input. DVD APC input pin from the monitor photo diode
23	CDPD	I	APC Input. CD APC input pin from the monitor photo diode
25	LDON#	I	APC Output On/Off. APC output control pin. A low level activates the LD output. (open high)
61, 62	ATON/ATOP	O	Differential Attenuator Output. Attenuator outputs
51, 52	FNN, FNP	O	Differential Normal Output. Filter normal outputs
57	SIGO	O	Single Ended Normal Output. Single ended RF output
64	CDRFDC	O	CD RF Signal Output. Single ended CD RF summing output
42	FE	O	Focusing Error Signal Output. Focus error output reference to VCI
41	TE	O	Tracking Error Signal Output. Tracking error output reference to VCI

Pin No.	Pin Name	Type	Description
43	CE	O	Center Error Signal Output. Center error output reference to VCI
34	NEVO	O	SIGO Bottom Envelope Output. Bottom envelope for mirror detection
37	DFT	O	Defect Output. Pseudo CMOS output. When a defect is detected, the DFT output goes high. Also the servo AGC output can be monitored at this pin, when CAR bits 7-4 are '0011'
29	MIRR	O	Mirror Detect Output. Mirror Detect comparator output. Pseudo CMOS output
36	PI	O	Pull-in Signal Output. The summing signal output of A, B, C, D or PD1, PD2 for mirror detection. Reference to VCI
22	DVDLD	O	APC output. DVD APC output pin to control the laser power
24	CDLD	O	APC output. CD APC output pin to control the laser power
56	BYP	I/O	The RF AGC integration capacitor CBYP, is connected between BYP and VPA
9	CP	I/O	Differential Phase tracking LPF pin. An external capacitance is connected between this pin and the CN pin
10	CN	I/O	Differential Phase tracking LPF pin. An external capacitance is connected between this pin and the CP pin
45	LCP	—	Center Error LPF pin. An external capacitance is connected between this pin and the LCN pin
44	LCN	—	Center Error LPF pin. An external capacitance is connected between this pin and the LCP pin
30	MP	—	MIRR signal Peak hold pin. An external capacitance is connected to between this pin and VPB
31	MB	—	MIRR signal Bottom hold pin. An external capacitance is connected to between this pin and VPB
39	MEV	—	Sigo Bottom Envelope pin. An external capacitance is connected to between this pin and VPB
17	CDTE	—	CD Tracking. E-F Opamp output for feedback
38	TPH	—	PI Top Hold pin. An external capacitance is connected to between this pin and VPB
26	VC	—	Reference Voltage output. This pin provides the internal DC bias reference voltage (+2.5V Iix). Output Impedance is less than 50ohms
27	VCI	—	Reference Voltage input. DC bias voltage input for the servo input reference
18	VCI2	—	Reference Voltage input. DC bias voltage input for the servo input reference
55	RX	—	Reference Resistor Input. An external 8.2kohm, 1% resistor is connected from this pin to ground to establish a precise PTAT (proportional to absolute temperature) reference current for the filter
33	MLPF	—	MIRR signal LPF pin. An external capacitance is connected between this pin and VPB
19	NC	—	No Connect
48	SDEN	I	Serial Data Enable. Serial Enable CMOS input. A high level input enable the serial port (Not to be left open)
47	SDATA	I/O	Serial Data. Serial data bi-directional CMOS pin. NRZ programming data for the internal registers is applied to this input (Not to be left open)
46	SCLK	I	Serial Clock. Serial Clock CMOS input. The clock applied to this pin is synchronized with the data applied to SDATA (Not to be left open)
58	VPA		Power. Power supply pin for the RF block and serial port
28	VPB		Power. Power supply pin for the servo block
50	VNA		Ground. Ground pin for the RF block and serial port
20	VNB		Ground. Ground pin for the servo block

TMP86CM47U-4V14 (PA: IC102)

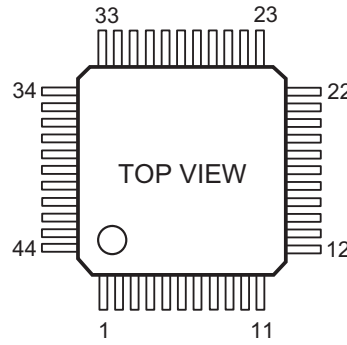

TMP86CM47U-4V14 Terminal Function

Pin No.	Pin Name	Symbol	I/O	DET	Ext	Ini	Res	Function
1	Vss	Vss						GND (0V)
2	XIN	XIN	I					Oscillation input 16.0MHz
3	XOUT	XOUT	O					Oscillation output
4	TEST	TEST	I					Fixed to L
5	Vdd	Vdd						Power (+5.0V)
6	P21	PITCHLED	O		Pu	H	H	LED ON/OFF (L:ON)
7	P22	EJECTLED	O		Pu	H	H	LED ON/OFF (L:ON)
8	RESET	RST	I					ucom RESET
9	P20	LED4	O		Pu	H	H	LED ON/OFF (L:ON)
10	P00	TRSB	I		Pu		H	Track select encoder B input
11	P01	PM LED	O		Pu	H	H	LED ON/OFF (L:ON)
12	P02	RXD	I		Pu		H	Data receive from main unit
13	P03	TXD	O		Pu	H	H	Data send to main unit
14	P04	FLDA	O		Pu	H	H	ML9207 data signal
15	P05	FLCS	O		Pu	H	H	ML9207 latch signal
16	P06	FLCP	O		Pu	H	H	Clock signal for ML9207 data output
17	P07	NEXT LED	O		Pu	H	H	LED ON/OFF (L:ON)
18	P17	KIN5	I		Pu		H	Key scan input 5
19	P16	KIN4	I		Pu		H	Key scan input 4
20	P15	KIN3	I		Pu		H	Key scan input 3
21	P14	KIN2	I		Pu		H	Key scan input 2
22	P13	KIN1	I		Pu		H	Key scan input 1
23	P12	KIN0	I		Pu		H	Key scan input 0
24	P11	TRSA	I	Ed	Pu		H	Track select encoder A interrupt input
25	P10	FLRES	O		Pd	L	L	ML9207 reset signal
26	P30	PITCH	I					Pitch VR signal
27	P31	PITCHC	I					Pitch VR center value signal
28	P32	MAIN LED	O		Pu	H	H	LED ON/OFF (L:ON)
29	P33	SAMP LED	O		Pu	H	H	LED ON/OFF (L:ON)
30	P34	DISC LED	O		Pu	H	H	LED ON/OFF (L:ON)
31	P35	KINAD	I		Pu	Å	H	Key A/D input
32	P36	PLAY	I/O		Pu	H	H	PLAY/PAUSE key scan (PLAY/PAUSE LED L:ON)
33	P37	CUE	I/O		Pu	H	H	CUE key scan (CUE LED L:ON)
34	VAREF	VAREF	I					Power (+5.0V), Analog ref. V for A/D conversion
35	AVDD	AVDD	I					Power (+5.0V), For A/D conversion circuit only
36	AVSS	AVSS	I					GND (0V), Analog GND for A/D conversion
37	P40	KOUT0	O		Pu	H	H	Key scan output 0/LED line select 0 (L: Select)
38	P41	KOUT1	O		Pu	H	H	Key scan output 1/LED line select 1 (L: Select)
39	P42	KOUT2	I/O		Pu	H	H	Key scan output 2/ (Other than scan, IN)
40	P43	KOUT3	I/O		Pu	H	H	Key scan output 3/ (Other than scan, IN)
41	P44	LED0	O			H		LED ON/OFF0 (L:ON)
42	P45	LED1	O			H		LED ON/OFF1
43	P46	LED2	O			H		LED ON/OFF2
44	P47	LED3	O			H		LED ON/OFF3

*Pd or Pu detected in input port when power on, Pd CD1, Pu CD2

TMP86CM47U-3RD2 (DS: IC151)

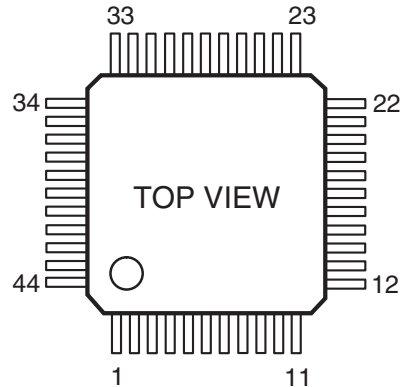

TMP86CM47U-3RD2 Terminal Function

Pin No.	Pin Name	Symbol	I/O	DET	Ext	Ini	Res	Function
1	VSS	VSS	—	—	—	—	—	GND (0V)
2	XIN	XIN	I	—	—	—	—	Oscillation input 8.0MHz
3	XOUT	XOUT	O	—	—	—	—	Oscillation output
4	TEST	TEST	I	—	—	—	—	Fixed to L
5	VDD	VDD	—	—	—	—	—	Power (+3.3V)
6	P21(LED)	DVSEL	O	—	Pu	L	H	Not used
7	P22	BREQ1_	O	—	Pu	H	H	System μ com bus request
8	RESET_	RST_	I	—	—	—	—	μ com reset
9	P20	DRLCH	O	—	Pu	H	H	ATAPI data register latch signal, H: Latch
10	P00(INT0)	MCMD_	I	—	—	—	—	System μ com serial interface
11	P01	DMA	O	—	Pu	L	H	ATAPI DMA mode select (H: DMA)
12	P02	DMABSY1	I	—	Pu	—	H	In DMA flag (L: DMA data transfer)
13	P03	ATANS	O	—	Pu	H	H	System μ com serial interface
14	P04(SO)	ATDATA	O	—	Pu	H	H	System μ com serial data receive signal
15	P05(SI)	MDATA	I	—	—	—	—	System μ com serial data send signal
16	P06(SCK_)	MCLK	I	—	—	—	—	System μ com serial send/receive clock
17	P07(INT4/LED)	BSYIN_	I	—	—	—	H	TXD BUSY input
18	P17	BSYOUT_	O	—	Pu	H	H	TXD BUSY output signal (L: BUSY)
19	P16	DRES_	O	—	Pd	L	L	DSP reset (L: Reset)
20	P15	DMAR_ /W	I/O	—	Pu/Pd	H	L/H	ATAPI DMA direction select (L: Read) *
21	P14	RD_	O	—	—	H	—	ATAPI read strobe
22	P13	WR_	O	—	—	H	—	ATAPI write strobe
23	P12(INT2)	INTRQ	I	Lv	—	—	—	ATAPI interrupt request signal
24	P11(INT1)	DMARQ	I	Lv	Pd	—	—	ATAPI DMA request signal (Pd with 5.6k Ω)
25	P10	IORDY	I	—	Pu	—	H	ATAPI data transfer cycle extend request signal (Pu with 1.0k Ω)
26	P30	D0	I/O	—	Pd	L	L	ATAPI data bus 0 (APRES_ATAPI reset)
27	P31	D1	I/O	—	—	—	—	ATAPI data bus 1 (CS1 device register chip select 1)
28	P32	D2	I/O	—	—	—	—	ATAPI data bus 2 (CS0 device register chip select 0)
29	P33	D3	I/O	—	—	—	—	ATAPI data bus 3 (DA2 device register select 2)
30	P34	D4	I/O	—	—	—	—	ATAPI data bus 4 (DA1 device register select 1)
31	P35	D5	I/O	—	—	—	—	ATAPI data bus 5 (DA0 device register select 0)
32	P36	D6	I/O	—	—	—	—	ATAPI data bus 6
33	P37	D7	I/O	—	—	—	—	ATAPI data bus 7
34	VAREF	VAREF	I	—	—	—	—	GND (0V), Analog ref. V for A/D conversion, A/D not used
35	AVDD	AVDD	I	—	—	—	—	Power (+3.3V), Power for A/D conversion circuit only
36	AVSS	AVSS	I	—	—	—	—	GND (0V), Analog GND for A/D conversion
37	P40	D8	I/O	—	—	—	—	ATAPI data bus 8
38	P41	D9	I/O	—	—	—	—	ATAPI data bus 9
39	P42	D10	I/O	—	—	—	—	ATAPI data bus 10
40	P43	D11	I/O	—	—	—	—	ATAPI data bus 11
41	P44	D12	I/O	—	—	—	—	ATAPI data bus 12
42	P45	D13	I/O	—	—	—	—	ATAPI data bus 13
43	P46	D14	I/O	—	—	—	—	ATAPI data bus 14
44	P47	D15	I/O	—	—	—	—	ATAPI data bus 15

* Pd or Pu detected in input port when power on, Pd=CD1, Pu=CD2

W29EE011P (CD: IC507)

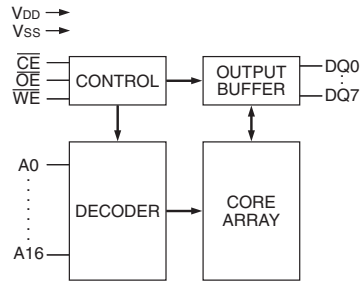
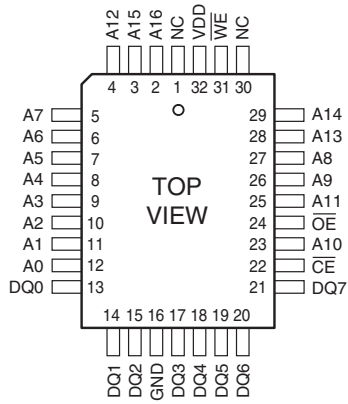

Terminal Function

Name	Function
A0 - A16	Address Inputs
DQ0 - DQ7	Data Inputs/Outputs
\overline{CE}	Chip Enable
\overline{OE}	Output Enable
\overline{WE}	Write Enable
VDD	Power Supply
GND	Ground
NC	No Connection

BD6670FM (CD: IC510)

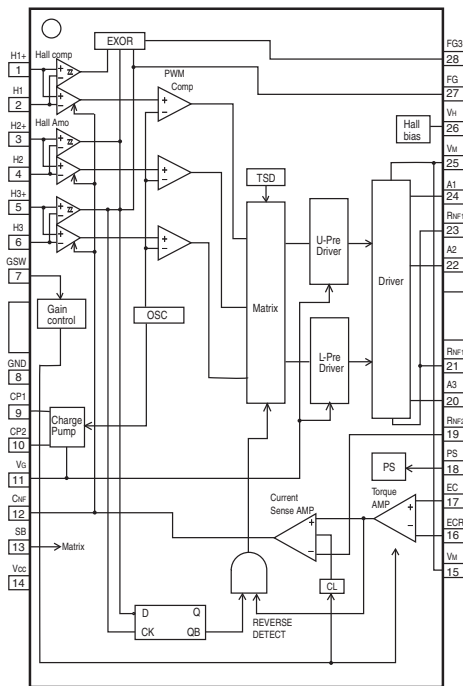

BD6670FM Terminal Function

Pin No.	Pin Name	Function
1	H1+	Hall input Amp 1 positive input
2	H1-	Hall input Amp 1 negative input
3	H2+	Hall input Amp 2 positive input
4	H2-	Hall input Amp 2 negative input
5	H3+	Hall input Amp 3 positive input
6	H3-	Hall input Amp 3 negative input
7	GSW	Gain switch pin
8	GND	GND
9	CP1	Capacitor pin 1 for charge pump
10	CP2	Capacitor pin 2 for charge pump
11	VG	Capacitor connection pin for charge pump
12	CNF	Capacitor connection pin for phase compensation
13	SB	Short Brake Pin
14	VCC	Power supply for signal division
15	VM	Power supply for driver
16	ECR	Torque control standard voltage input terminal
17	EC	Torque control voltage input terminal
18	PS	Power Save in
19	RNF2	Resistor connection pin for current sense
20	A3	Output3 for motor
21	RNF1	Resistor connection pin for current sense
22	A2	Output2 for motor
23	RNF1	Resistor connection pin for current sense
24	A1	Output1 for motor
25	VM	Power supply for driver
26	VH	Hall bias pin
27	FG	FG output pin
28	FG3	FG3 output pin

BA5954FP (CD: IC509)

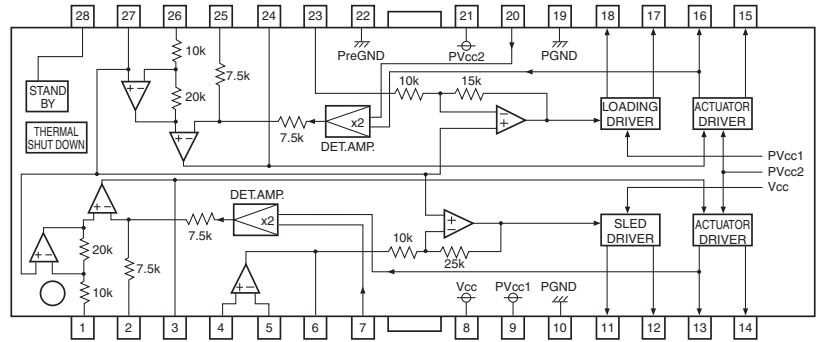

BA5954FP Terminal Function

Pin No.	Pin Name	Function	Pin No.	Pin Name	Function
1	VINFC	Focus driver input	15	VOTK+	Output (+) of tracking driver
2	CFCerr1	Cap. connection pin for error amp filter	16	VOTK-	Output (-) of tracking driver
3	CFCerr2	Cap. connection pin for error amp filter	17	VOLD+	Output (+) of loading driver
4	VINSL+	Op. amp input (+) for sled driver	18	VOLD-	Output (-) of loading driver
5	VINSL-	Op. amp input (-) for sled driver	19	PGND	Power GND
6	VOSL	Op. amp output for sled driver	20	VNFTK	Tracking driver feedback pin
7	VNFFC	Focus driver feedback pin	21	PVcc2	Power Vcc for actuator driver
8	Vcc	Pre Vcc, power Vcc for sled driver	22	PreGND	Pre GND
9	PVcc1	Power Vcc for loading driver	23	VINLD	Loading driver input
10	PGND	Power GND	24	CTKerr2	Cap. connection pin for error amp filter
11	VOSL-	Output (-) of sled driver	25	CTKerr1	Cap. connection pin for error amp filter
12	VOSL+	Output (+) of sled driver	26	VINTK	Tracking driver input
13	VOFC-	Output (-) of focus driver	27	BIAS	Bias input
14	VOFC+	Output (+) of focus driver	28	STBY	Standby pin

AK4353VF (DS: IC709)

Block Diagram

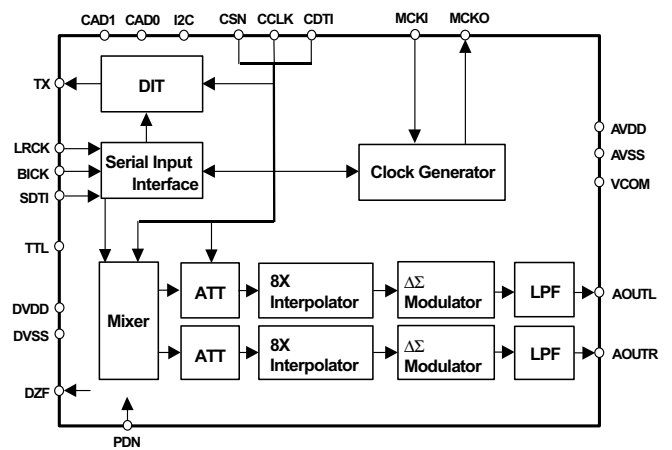
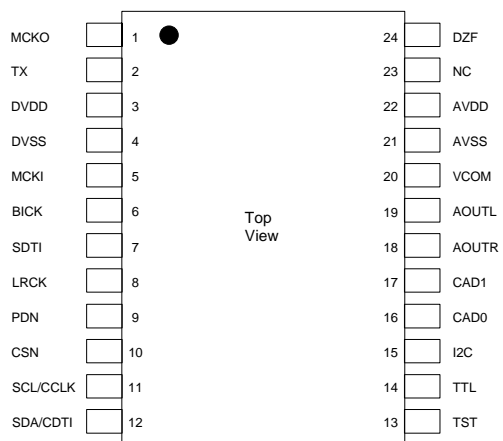

AK4353VF Terminal Function

No.	Pin Name	I/O	Description
1	MCKO	O	Master Clock Output Pin Same frequency as MCKI is output
2	TX	O	Transmit Channel Output Pin
3	DVDD	-	Digital Power Supply Pin, +2.7~+5.5V
4	DVSS	-	Digital Ground Pin, 0V
5	MCKI	I	Master Clock Input Pin
6	BICK	I	Serial Data Clock Pin
7	SDTI	I	Serial Data Input Pin
8	LRCK	I	Serial Input Channel Clock Pin
9	PDN	I	Power-Down Pin When "L", the circuit is in power-down mode. The AK4353 should always be reset upon power-up.
10	CSN	I	Chip Select Pin at 3-wire Serial control mode This pin should be connected to DVDD at I ² C Bus control mode.
11	SCL	I	Control Clock Pin at I ² C bus control mode
	CCLK	I	Control Clock Pin at 3-wire serial control mode
12	SDA	I/O	Control Data Input/Output Pin at I ² C Bus control mode
	CDTI	I	Control Data Input Pin at 3-wire serial control mode
13	TST	I	Test pin This pin should be connected to DVDD.
14	TTL	I	Digital Input Level Select Pin "L": CMOS, "H": TTL
15	I2C	I	Control Mode Select Pin "L": 3-wire Serial, "H": I ² C Bus
16	CAD0	I	Chip Address Select 0 Pin
17	CAD1	I	Chip Address Select 1 Pin
18	AOUTR	O	Rch Analog Output Pin
19	AOUTL	O	Lch Analog Output Pin
20	VCOM	O	Common Voltage Output Pin, AVDD/2 Used for analog common voltage. Large external capacitor is used to reduce power supply noise.
21	AVSS	-	Analog Ground Pin
22	AVDD	-	Analog Power Supply Pin
23	NC	-	No Connect Nothing should be connected externally to this pin.
24	DZF	O	Zero Input Detect Pin When SDTI follows a total 8192 LRCK cycles with "0" input data or RSTN = "0", this pin goes to "H".

Note: No input pins should be left floating.

TA7291F (DS: IC512)

TA7291F Terminal Function

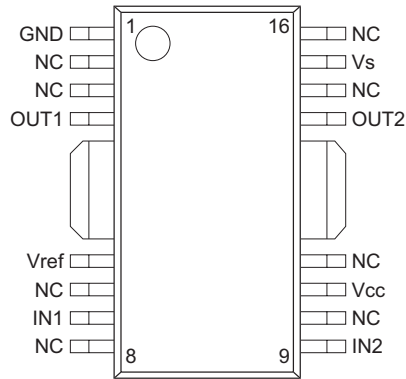

PIN No.	SYMBOL	FUNCTION DESCRIPTION
11	Vcc	Supply voltage terminal for Logic
15	Vs	Supply voltage terminal for Motor driver
5	Vref	Supply voltage terminal for control
1	GND	GND terminal
7	IN1	Input terminal
9	IN2	Input terminal
4	OUT1	Output terminal
13	OUT2	Output terminal

STR-F6674 (PA: IC901)

GP1A70R (PA: IC251,252)

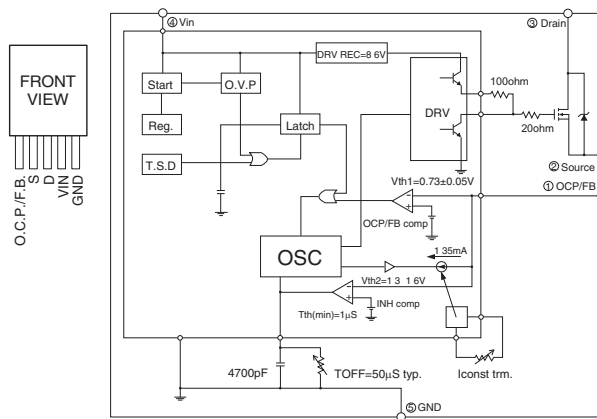

SIDE VIEW

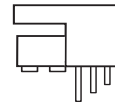

BOTTOM VIEW

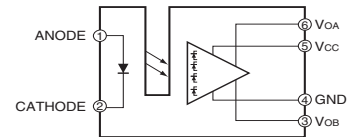
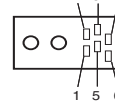

SN74LV393APW (DS: IC710)

SE005N (PA: IC903)

PC123 (PA: IC902)

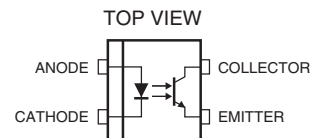
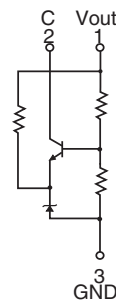
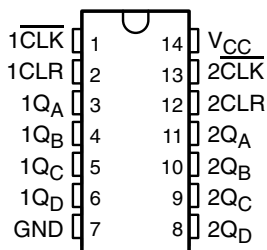

2. FL DISPLAY 24-ST-09GN (FL101)

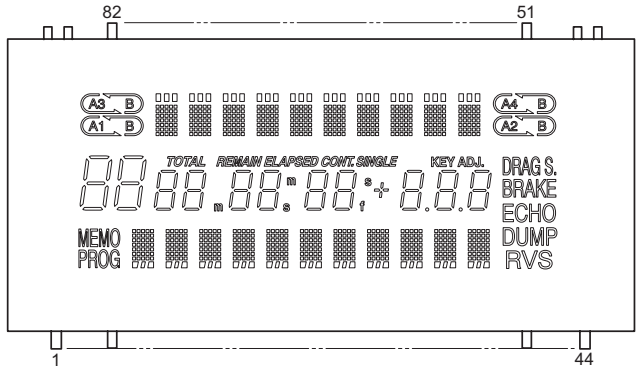

Pin Connection

Pin No.	8	8	8	8	8	8	8	8	7	7	7	7	7	7	7	7	6	6	6	6	6	6	6	6	5	5	5	5	5	5	5	4	4	4	4			
Connection	N	N	N	N	N	P	P	P	P	P	P	P	P	P	P	P	P	P	P	P	P	1	0	9	8	7	6	5	4	3	2	1	0	9	8	7	6	5

Pin No.	1	2	3	4	5	6	7	8	9	10	11	11	12	13	14	15	16	17	18	19	20	21	22	23	24	25	26	27	28	29	30	31	32	33	34	35	36	37	38	39	40	41	42	43	44		
Connection	F	F	F	F	N	P	I	C	1	2	2	2	2	2	2	2	2	2	2	3	3	3	3	3	3	3	3	2	2	2	1	1	1	1	1	1	1	1	1	1	1	1	1	1	1	1	1

NOTE: 1) F-, F+ Filament 2) NP No Pin 3) DL Datum Line 4) 1G~24G Grid
 5) IC Internal Connection 6) Visual Field Upper 26°, lower 26°(min.)

Grid Assignment

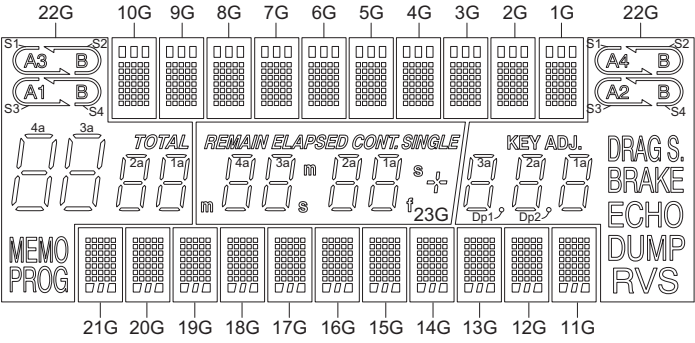

Segment Designation

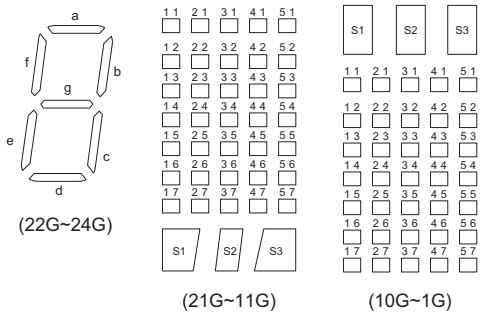

Anode Connection

	24G	23G	22G	21G~1G		24G	23G	22G	21G~1G
P1	RVS	1d	1d	1-1	P21	Dp1	3b	3a	1-5
P2	DUMP	1e	1e	2-1	P22	2d	3a	TOTAL	2-5
P3	ECHO	1c	1c	3-1	P23	2e	4d	MEMO	3-5
P4	BRAKE	1g	1g	4-1	P24	2c	4e	PROG	4-5
P5	DRAG S.	1f	1f	5-1	P25	2g	4c	4d	5-5
P6	↶	1b	1b	1-2	P26	2f	4g	4e	1-6
P7	A4	1a	1a	2-2	P27	2b	4f	4c	2-6
P8	↷	2d	2d	2-2	P28	2a	4b	4g	2-6
P9	B	2e	2e	4-2	P29	Dp2	4a	4f	4-6
P10	↶	2c	2c	5-2	P30	KEY ADJ.	m	4b	5-6
P11	A2	2g	2g	1-3	P31	3d	?	4a	1-7
P12	↷	2f	2f	2-3	P32	3e	--	A1	2-7
P13	B	2b	2b	3-3	P33	3c	;	↶	3-7
P14	1d	2a	2a	4-3	P34	3g	m	B	4-7
P15	1e	s	3d	5-3	P35	3f	s	↷	5-7
P16	1c	3d	3e	1-4	P36	3b	REMAIN	A3	S-1
P17	1g	3e	3c	2-4	P37	3a	ELAPSED	↶	S-2
P18	1f	3c	3g	3-4	P38	—	CONT	B	S-3
P19	1b	3g	3f	4-4	P39	—	SINGLE	↷	—
P20	1a	3f	3b	5-4					

PRINTED WIRING BOARDS
GU-3414 CD-ROM P.W.B. UNIT

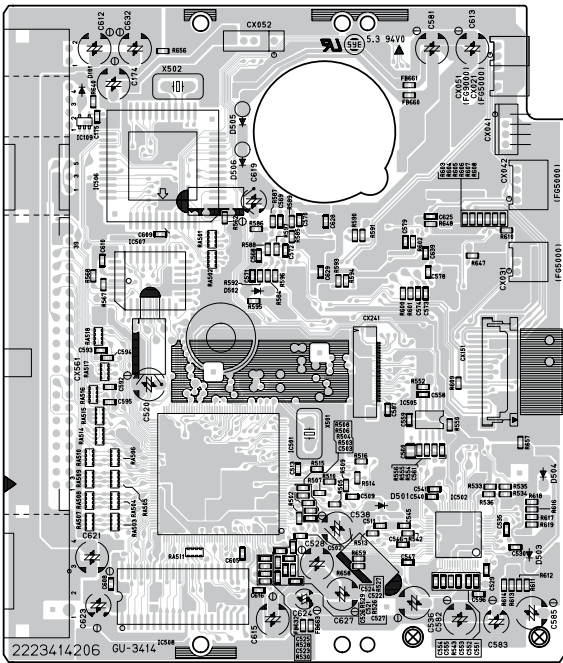

COMPONENT SIDE

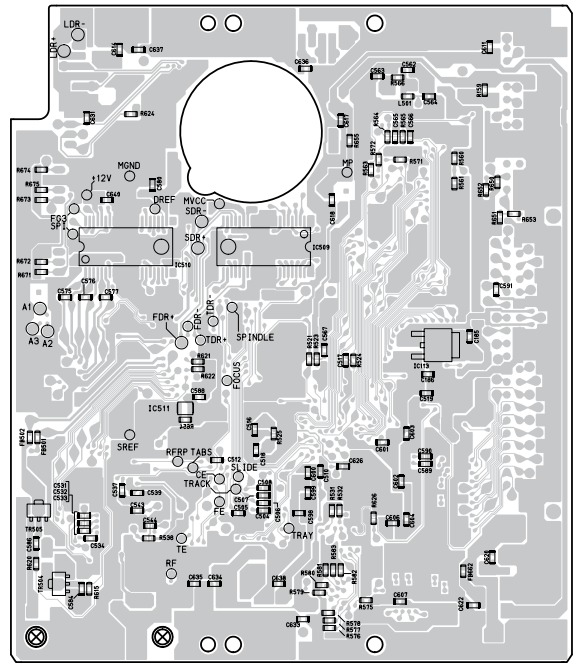

FOIL SIDE

GU-3546 DSP P.W.B. UNIT

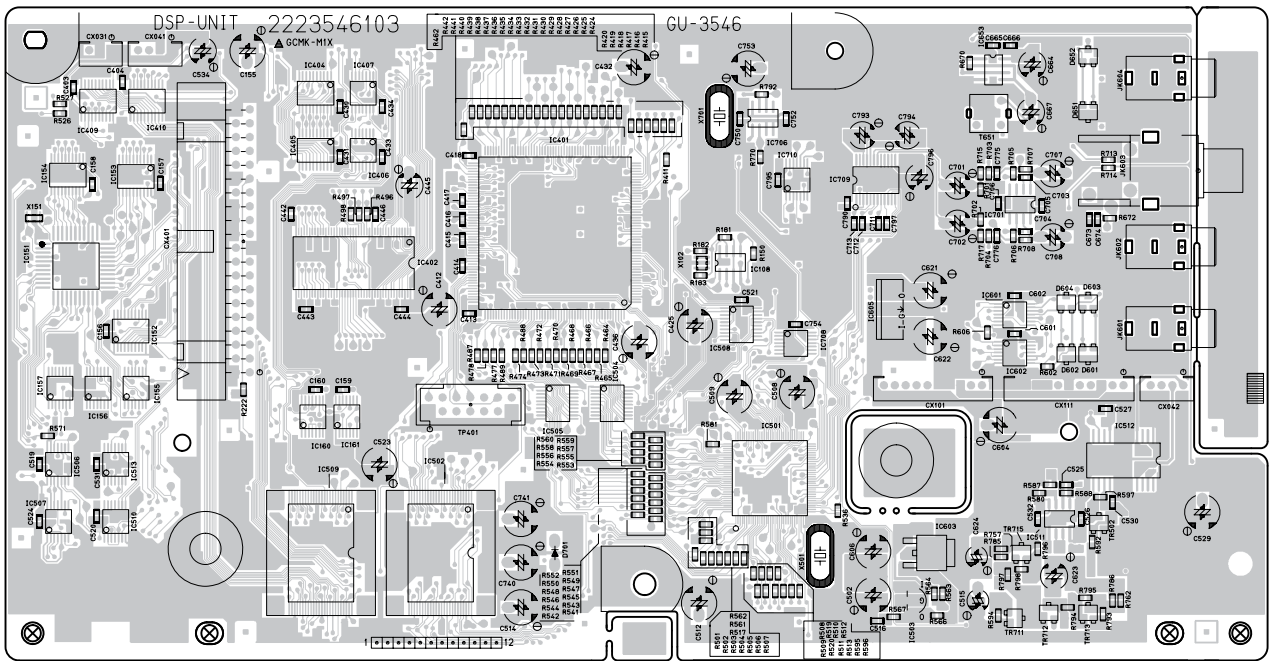

COMPONENT SIDE

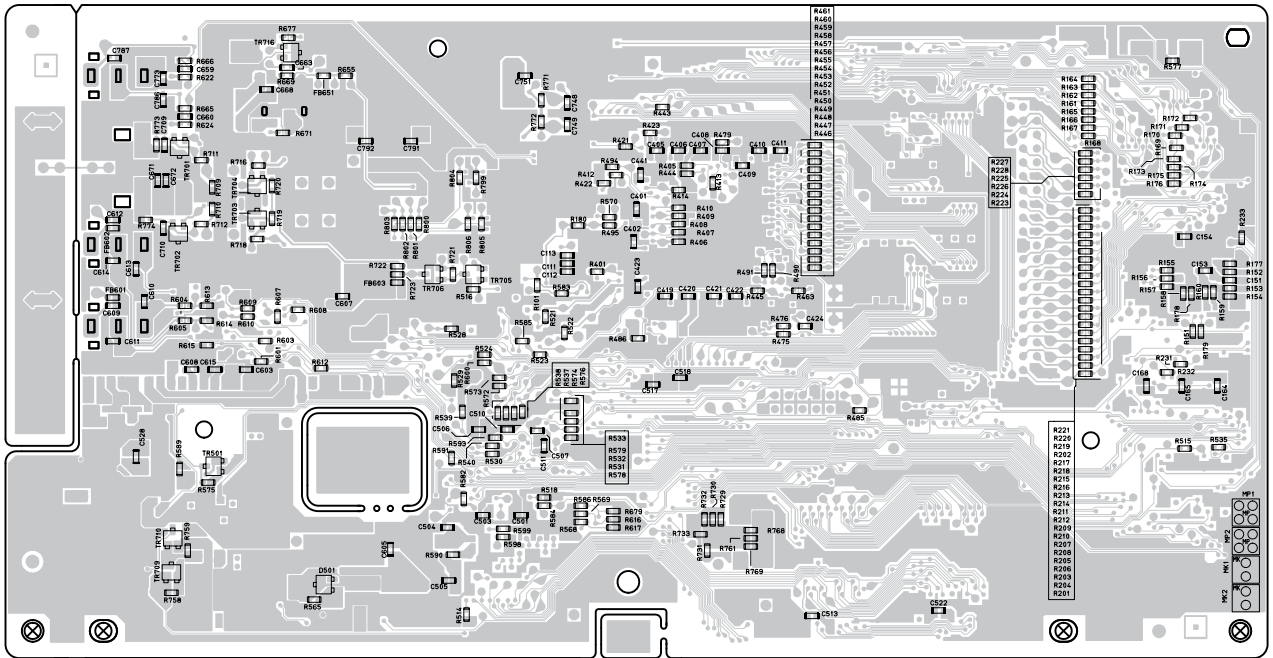

FOIL SIDE

GU-3547 PANEL P.W.B. UNIT

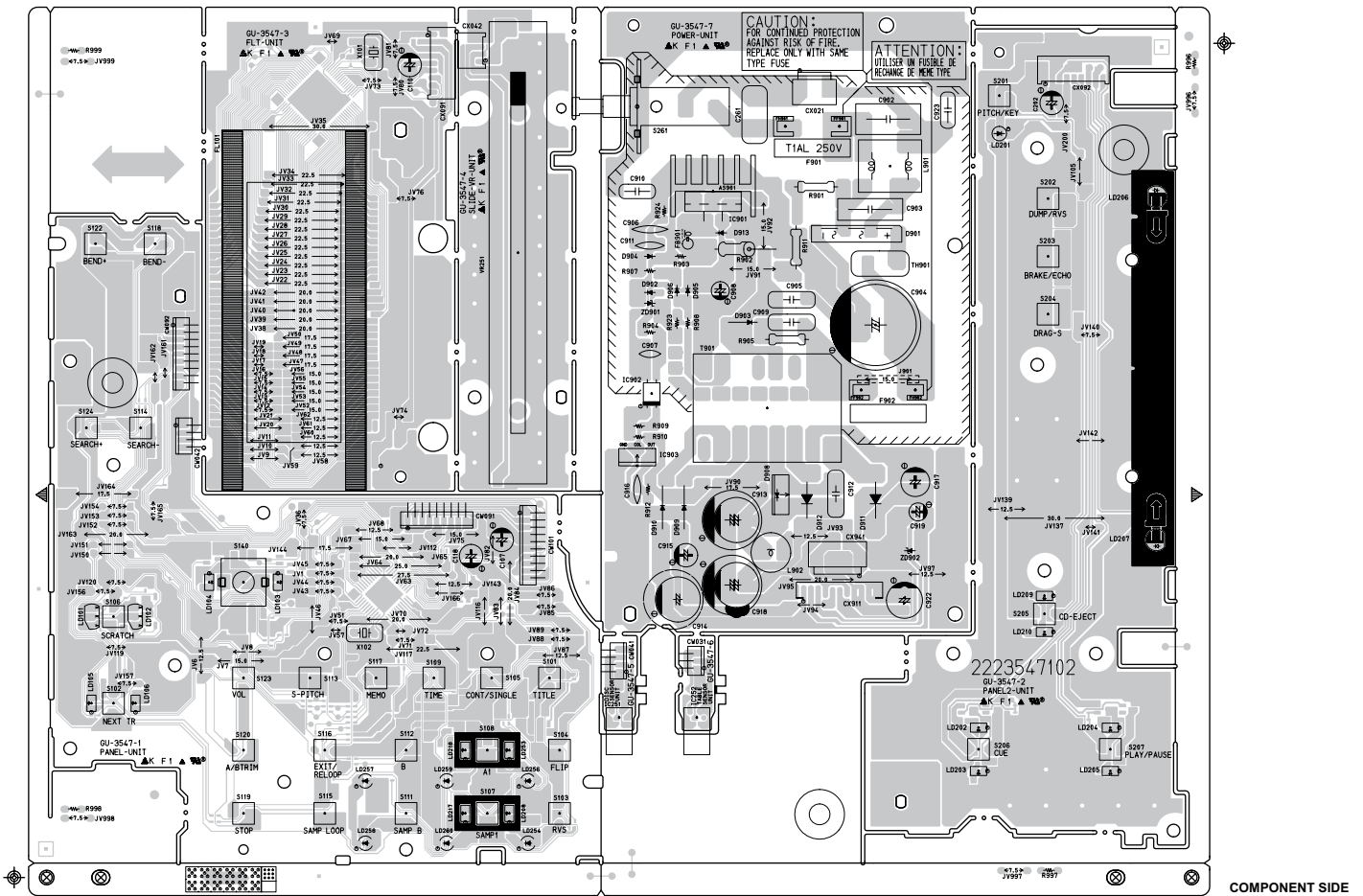

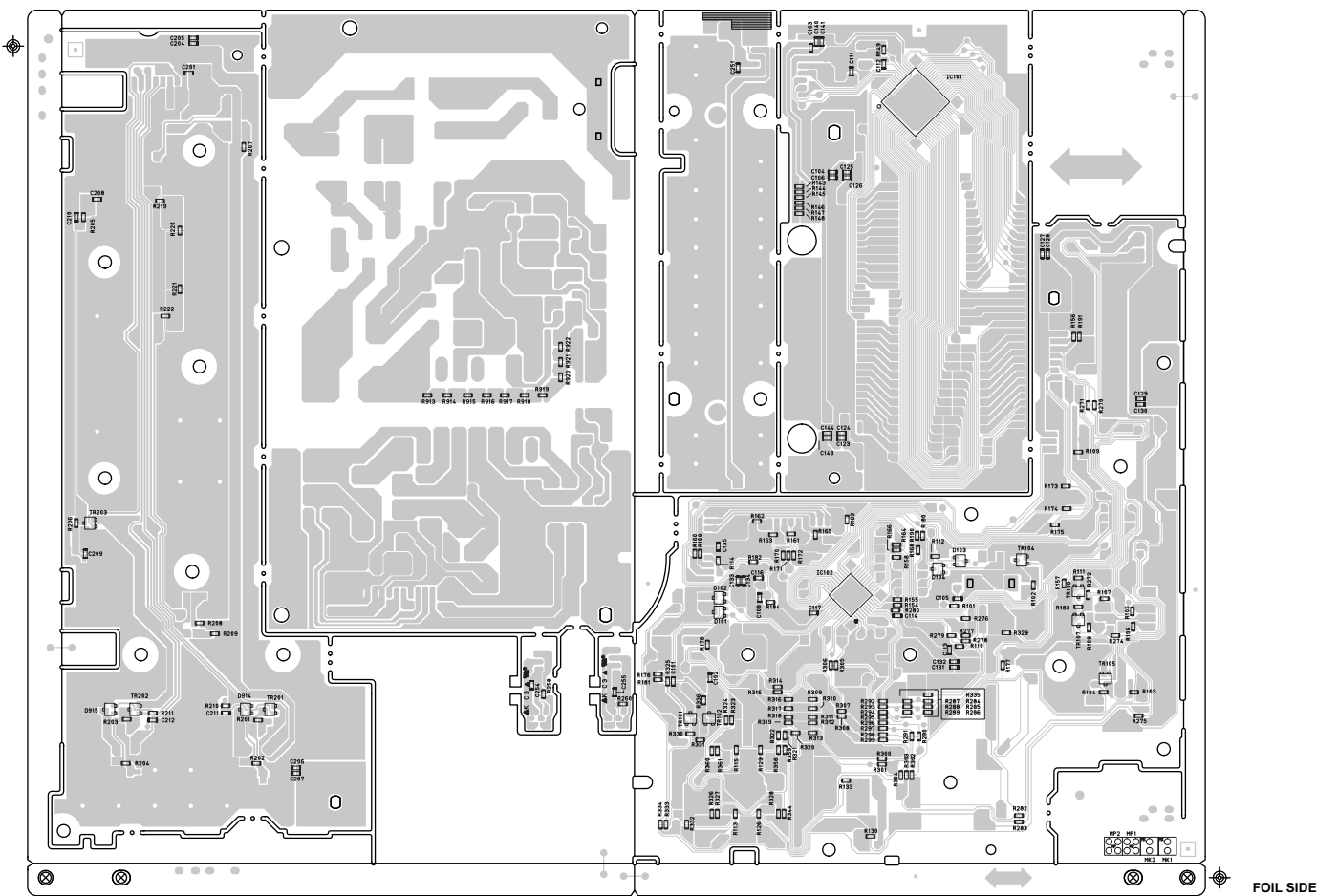

NOTE FOR PARTS LIST

- Part indicated with the mark "◎" are not always in stock and possibly to take a long period of time for supplying, or in some case supplying of part may be refused.
 - When ordering of part, clearly indicate "1" and "1" (i) to avoid mis-supplying.
 - Ordering part without stating its part number can not be supplied.
 - Part indicated with the mark "★" is not illustrated in the exploded view.
 - Not including Carbon Film Resistor ±5%, 1/4W Type in the P.W.Board parts list. (Refer to the Schematic Diagram for those parts.)
 - Not including Carbon Chip Resistor 1/16W Type in the P.W.Board parts list. (Refer to the Schematic Diagram for those parts.)
- WARNING:**
Parts marked with this symbol \triangle have critical characteristics.
Use ONLY replacement parts recommended by the manufacturer.

部品表について

- 印の部品は常時在庫していませんので供給に長時間を要することがあります。
場合によっては、供給をお断りすることがあります。
- 部品を発注する際は特に数字の“1”と英字の“1”との区別をはっきり記入してください。
- 部品番号を表示していない部品は供給できません。
- \triangle 印の部品は安全上重要な部品です。交換するときは、安全および性能維持のため必ず指定の部品をご使用ください。
- ★印のついている部品は分解図中には記載していません。
- カーボン抵抗器±5%、1/4W型は記載していません。定数は回路図を参照願います。
- カーボンチップ抵抗器1/16W型は記載していません。定数は回路図を参照願います。
- 部品表の抵抗器、コンデンサの品名記号の読み方は表を参照してください。

● Resistors

Ex.: $\frac{RN}{Type}$ $\frac{14K}{Shape\ and\ performance}$ $\frac{2E}{Power}$ $\frac{182}{Resist-ance}$ $\frac{G}{Allowable\ error}$ $\frac{FR}{Others}$

RD : Carbon RC : Composition RS : Metal oxide film RW : Winding RN : Metal film RK : Metal mixture	2B : 1/8W 2E : 1/4W 2H : 1/2W 3A : 1W 3D : 2W 3F : 3W 3H : 5W	F : ±1% G : ±2% J : ±5% K : ±10% M : ±20%	P : Pulse-resistant type NL : Low noise type NB : Non-burning type FR : Fuse-resistor F : Lead wire forming
---	---	---	---

* Resistance

$\frac{1}{\uparrow} \frac{8}{\uparrow} \frac{2}{\uparrow} \Rightarrow 1800\ ohm = 1.8\ kohm$
Indicates number of zeros after effective number.
2-digit effective number.

Units: ohm

$\frac{1}{\uparrow} \frac{R}{\uparrow} \frac{2}{\uparrow} \Rightarrow 1.2\ ohm$
1-digit effective number.
2-digit effective number, decimal point indicated by R.

Units: ohm

● 抵抗器

例) $\frac{RN}{種類}$ $\frac{14K}{形状特性}$ $\frac{2E}{電力}$ $\frac{182}{抵抗値}$ $\frac{G}{許容差}$ $\frac{FR}{その他}$

RD : カーボン RC : 固定体 RS : 金属系皮膜 RW : 巻線 RN : 金属皮膜 RK : 金属混合体	2B : 1/8 W 2E : 1/4 W 2H : 1/2 W 3A : 1 W 3D : 2 W 3F : 3 W 3H : 5 W	F : ±1% G : ±2% J : ±5% K : ±10% M : ±20%	P : 耐パルス形 NL : 低雑音形 NB : 不燃形 FR : ヒューズ抵抗 F : リード線成形
---	--	---	---

* 抵抗値

$\frac{18}{\uparrow} \frac{2}{\uparrow} \Rightarrow 1800\ \Omega = 1.8k\ \Omega$
有効数字につづく0の数を表わす。
2桁の有効数字を表わす。

$\frac{1R}{\uparrow} \frac{2}{\uparrow} \Rightarrow 1.2\ \Omega$
1桁の有効数字を表わす。
2桁の有効数字で小数点はRで表わす。
単位は Ω

● Capacitors

Ex.: $\frac{CE}{Type}$ $\frac{04W}{Shape\ and\ performance}$ $\frac{1H}{Dielectric\ strength}$ $\frac{2R2}{Capacity}$ $\frac{M}{Allowable\ error}$ $\frac{BP}{Others}$

CE : Aluminum foil electrolytic CA : Aluminum solid electrolytic CS : Tantalum electrolytic CO : Film CK : Ceramic CC : Ceramic CP : Oil CM : Mica CF : Metallized CH : Metallized	0J : 6.3V 1A : 10V 1C : 16V 1E : 25V 1V : 35V 1H : 50V 2A : 100V 2B : 125V 2C : 160V 2D : 200V 2E : 250V 2H : 500V 2J : 630V	F : ±1% G : ±2% J : ±5% K : ±10% M : ±20% Z : +80% -20% P : +100% -0% C : ±0.25pF D : ±0.5pF = : Others	HS : High stability type BP : Non-polar type HR : Ripple-resistant type DL : For change and discharge HF : For assuring high frequency U : UL part C : CSA part W : UL-CSA type F : Lead wire forming
---	--	--	---

* Capacity (electrolyte only)

$\frac{2}{\uparrow} \frac{2}{\uparrow} \frac{2}{\uparrow} \Rightarrow 2200\ \mu F$
Indicates number of zeros after effective number.
2-digit effective number.

Units: μF .

$\frac{2}{\uparrow} \frac{R}{\uparrow} \frac{2}{\uparrow} \Rightarrow 2.2\ \mu F$
1-digit effective number.
2-digit effective number, decimal point indicated by R.

Units: μF .

* Capacity (except electrolyte)

$\frac{2}{\uparrow} \frac{2}{\uparrow} \frac{2}{\uparrow} \Rightarrow 2200pF = 0.0022\ \mu F$
(More than 2) — Indicates number of zeros after effective number.
2-digit effective number.

Units: pF.

$\frac{2}{\uparrow} \frac{2}{\uparrow} \frac{1}{\uparrow} \Rightarrow 220pF$
(0 or 1) — Indicates number of zeros after effective number.
2-digit effective number.

Units: pF.

● When the dielectric strength is indicated in AC, "AC" is included after the dielectric strength value.

● コンデンサ

例) $\frac{CE}{種類}$ $\frac{04W}{形状特性}$ $\frac{1H}{耐圧}$ $\frac{2R2}{容量}$ $\frac{M}{許容差}$ $\frac{BP}{その他}$

CE : アルミ箔電解 CA : アルミ固体電解 CS : タンタル電解 CQ : フィルム CK : セラミック CC : セラミック CP : オイル CM : マイカ CF : メタライズド CH : メタライズド	0J : 6.3 V 1A : 10 V 1C : 16 V 1E : 25 V 1V : 35 V 1H : 50 V 2A : 100 V 2B : 125 V 2C : 160 V 2D : 200 V 2E : 250 V 2H : 500 V 2J : 630 V	F : ±1% G : ±2% J : ±5% K : ±10% M : ±20% Z : +80% -20% P : +100% - 0% C : ±0.25pF D : ±0.5pF = : その他	HS : 高安定形 BP : 無極性形 HR : 耐リップル形 DL : 充放電対策用 HF : 高周波保証用 U : UL 部品 C : CSA 部品 W : UL-CSA 部品 F : リード線成形
---	---	--	---

* 容量値

● 電解コンデンサの場合

$\frac{22}{\uparrow} \frac{2}{\uparrow} \Rightarrow 2200\ \mu F$
有効数字につづく0の数を表わす。
2桁の有効数字を表わす。
単位は μF

$\frac{2R}{\uparrow} \frac{2}{\uparrow} \Rightarrow 2.2\ \mu F$
1桁の有効数字を表わす。
2桁の有効数字で小数点はRで表わす。
単位は μF

● 電解コンデンサ以外の場合

$\frac{22}{\uparrow} \frac{2}{\uparrow} \Rightarrow 2200pF = 0.0022\ \mu F$
有効数字につづく0の数を表わす。
(0の数が2以上の場合)
2桁の有効数字を表わす。
単位はpF

$\frac{22}{\uparrow} \frac{1}{\uparrow} \Rightarrow 220pF$
有効数字につづく0の数を表わす。
(0の数が0または1の場合)
2桁の有効数字を表わす。
単位はpF

● 耐圧を交流で表示する場合は、耐圧表示の次に「AC」を表示します。

PARTS LIST OF P.W.B. UNIT

*本表に記載されている部品は、補修用部品のため製品に使用している部品とは一部、形状、寸法などが異なる場合があります

Note: The symbols in the column "Remarks" indicate the following destinations.
 E3: U.S.A. & Canada model E2: Europe model
 JP: Japan model

GU-3414A CD-ROM P.W.B. UNIT ASS'Y

Ref.No.	Part No.	Part Name	Remarks	Q'ty	New
SEMICONDUCTORS GROUP					
IC109	262 3082 908	BD4743G			
IC113	263 1079 903	BA033FP			
IC501	262 3083 004	M5705			
IC502	262 3084 003	SP 3721A			
IC505	262 3085 905	TL3472			
IC507	262 3086 001	W29EE011P 90	M11B416256A 35J		
IC508	GEN 6439	FG5000 ROM ASS'Y			
IC509	262 3088 902	BA5954FP			
IC510	262 3089 901	BD6670FM			
TR504,505	272 0160 901	2SB1132T100Q			
D101	276 0401 905	1SS133T77 (TAPE)			
D502 504	276 0401 905	1SS133T77 (TAPE)			
RESISTORS GROUP					
RA501,502	247 9002 909	MNR14=330JE0AB			
RA503 506	247 9007 904	MNR14=101JE0			
RA507 510	247 9007 917	MNR14=103JE0			
RA511	247 9002 909	MNR14=330JE0AB			
RA514	247 9002 909	MNR14=330JE0AB			
RA515	247 9007 917	MNR14=103JE0			
RA516	247 9002 909	MNR14=330JE0AB			
RA517	247 9007 917	MNR14=103JE0			
RA518	247 9002 909	MNR14=330JE0AB			
CAPACITORS GROUP					
C174	254 4299 964	CE04W1C470MT(SRE)			
C185,186	257 0512 903	CK73F1E104ZT			
C502	257 0509 929	CK73B1H102KT			
C503	257 0510 950	CK73B1H682KT			
C505,506	257 0508 917	CC73CH1H471JT			
C507,508	257 0516 941	CK73B1E473KT			
C509,510	257 0516 954	CK73B1E104KT			
C511,512	257 0509 929	CK73B1H102KT			
C513	257 0516 954	CK73B1E104KT			
C516	257 0504 908	CC73CH1H220JT			
C517	257 0504 982	CC73CH1H470JT			
C518	257 0504 908	CC73CH1H220JT			
C519	257 0512 903	CK73F1E104ZT			
C520	254 4533 950	CE04W0J471MT SMG/RE3			
C521 523	257 0516 954	CK73B1E104KT			
C524	257 0504 982	CC73CH1H470JT			
C525	257 0508 933	CC73CH1H561JT			

Ref.No.	Part No.	Part Name	Remarks	Q'ty	New
C526	257 0516 941	CK73B1E473KT			
C527	257 0512 903	CK73F1E104ZT			
C528	254 4300 963	CE04W0J101MT(SRE)			
C529	257 0508 959	CC73CH1E681JT			
C530	257 0516 954	CK73B1E104KT			
C531 534	257 0508 959	CC73CH1E681JT			
C535	257 0506 951	CC73CH1H101JT			
C536	254 4300 963	CE04W0J101MT(SRE)			
C537	257 0512 903	CK73F1E104ZT			
C538	254 4533 921	CE04W0J101MT SMG/RE3			
C539	257 0512 903	CK73F1E104ZT			
C540	257 0510 934	CK73B1H472KT			
C541	257 0509 929	CK73B1H102KT			
C543	257 0507 918	CC73CH1H181JT			
C544	257 0509 929	CK73B1H102KT			
C545	257 0516 954	CK73B1E104KT			
C546	257 0516 941	CK73B1E473KT			
C547	257 0508 959	CC73CH1E681JT			
C551 555	257 0516 954	CK73B1E104KT			
C558	257 0516 954	CK73B1E104KT			
C559	257 0512 903	CK73F1E104ZT			
C560	257 0033 903	CK73B1E474KT			
C561	257 0504 940	CC73CH1H330JT			
C568	257 0512 903	CK73F1E104ZT			
C569	257 0506 951	CC73CH1H101JT			
C570	257 0510 934	CK73B1H472KT			
C571,572	257 0506 951	CC73CH1H101JT			
C573,574	257 0516 954	CK73B1E104KT			
C575 577	257 0509 929	CK73B1H102KT			
C578	257 0516 954	CK73B1E104KT			
C579,580	257 0512 903	CK73F1E104ZT			
C581	254 4193 947	CE04W1C101MT (SRA)			
C582	254 4300 963	CE04W0J101MT(SRE)			
C583	254 4299 919	CE04W1C220MT(SRE)			
C584	257 0509 929	CK73B1H102KT			
C585	254 4300 963	CE04W0J101MT(SRE)			
C586	257 0509 929	CK73B1H102KT			
C587,588	257 0512 903	CK73F1E104ZT			
C589,590	257 0503 925	CC73CH1H100DT			
C592 595	257 0503 925	CC73CH1H100DT			
C596	257 0512 903	CK73F1E104ZT			
C598 608	257 0512 903	CK73F1E104ZT			
C610,611	257 0512 903	CK73F1E104ZT			
C612	254 4193 947	CE04W1C101MT (SRA)			
C613	254 4300 963	CE04W0J101MT(SRE)			
C614	257 0512 903	CK73F1E104ZT			
C615	254 4300 963	CE04W0J101MT(SRE)			
C616	257 0508 917	CC73CH1H471JT			
C617,618	257 0512 903	CK73F1E104ZT			
C619	254 4538 942	CE04W1C101MT SMG/RE3			
C620	257 0512 903	CK73F1E104ZT			
C621	254 4300 963	CE04W0J101MT(SRE)			
C622	257 0512 903	CK73F1E104ZT			
C623,624	254 4300 963	CE04W0J101MT(SRE)			
C625	257 0501 901	CK73B1H103KT (1608)			
C626	257 0510 934	CK73B1H472KT			

Ref.No.	Part No.	Part Name	Remarks	Q'ty	New
C627	254 4300 963	CE04W0J101MT(SRE)			
C628,629	257 0512 903	CK73F1E104ZT			
C632	254 4193 947	CE04W1C101MT (SRA)			
C633 640	257 0512 903	CK73F1E104ZT			
OTHER PARTS GROUP					
CX031	205 0355 033	3P KR CON BASE(L)			
CX042	205 0355 046	4P KR CON BASE(L)			
CX151	205 1224 901	15P FFC BASE(P=1.0)L			
CX241	205 1225 900	24P FFC BASE(P=0.5)L			
CX561	205 1231 004	IDE CONNECTOR(56P)			
FB501,502	235 0130 903	CHIP EMIFIL(11A121)			
FB632	235 0158 901	CHIP BEADS(18PG121)			
FB660 663	235 0158 901	CHIP BEADS(18PG121)			
X501	399 0790 906	CSALS33M8X51 A0			

GU-3546 DSP P.W.B. UNIT ASS'Y

Ref.No.	Part No.	Part Name	Remarks	Q'ty	New
SEMICONDUCTORS GROUP					
IC151	262 3139 000	TMP86CM47U 3RD2(AT)			
IC152	262 2642 909	SN74LV573APW EL2			
IC153,154	262 2640 901	SN74LV245APW EL2			
IC155	262 2517 908	SN74LV08APW EL2			
IC157	262 2519 906	SN74LV00APW EL2			
IC160	262 2519 906	SN74LV00APW EL2			
IC161	262 2518 907	SN74LV74APW EL2			
IC401	262 3115 008	ADSP 21065L(MP3)			
IC402	262 3307 007	128M SDRAM(32B TSOP)			*
IC404,405	262 2642 909	SN74LV573APW EL2			
IC406	262 2729 903	SN74LV02APW EL2			
IC407	262 2516 909	SN74LV32APW EL2			
IC501	262 3044 001	MN102H730F			
IC502	GEN 6495	IC502 SYSTEM ROM SUB ASS'Y	8M FLASH MEMORY(70N)		
IC503	263 0913 905	PST600C TP			
IC504,505	262 2640 901	SN74LV245APW EL2			
IC506	262 2518 907	SN74LV74APW EL2			
IC507	262 2948 904	SN74LV86APW			
IC508	262 2959 906	SN74LV244APW			
IC509	262 3043 002	4M FLASH MEMORY(70N)			
IC510	262 2517 908	SN74LV08APW EL2			
IC511	263 0615 902	BA15218F DXE2			
IC512	262 3183 904	TA7291F			
IC513	262 2518 907	SN74LV74APW EL2			
IC601	262 2515 900	SN74LV04APW EL2			
IC602	262 2813 903	SN74AHCT08PW EL2			
IC603	263 1079 903	BA033FP			
IC653	262 1953 903	TC7WU04F			
IC701	263 0615 902	BA15218F DXE2			
IC706	262 1953 903	TC7WU04F			
IC708	262 2517 908	SN74LV08APW EL2			
IC709	262 3306 901	AK4353VF			*
IC710	262 3305 902	SN74LV393APW			*
TR501,502	269 0082 902	DTC114EKT96			
TR701,702	273 0460 905	KTC2875B RTK			
TR709	269 0083 901	DTA114EKT96			
TR710,711	269 0082 902	DTC114EKT96			
TR712	269 0083 901	DTA114EKT96			
TR713	273 0437 909	2SC2411K T146			
TR715	271 0260 905	2SA1036KT146(S/R)			
TR716	273 0460 905	KTC2875B RTK			
D501	276 0559 909	DAP202KT146			
D601,602	276 0559 909	DAP202KT146			
D603,604	276 0560 901	DAN202KT146			
D651	276 0559 909	DAP202KT146			
D652	276 0560 901	DAN202KT146			
D701	276 0432 903	1SS270A TE (TAPE)			

Ref.No.	Part No.	Part Name	Remarks	Q'ty	New
CAPACITORS GROUP					
C151	257 0509 929	CK73B1H102KT			
C153,154	257 0512 903	CK73F1E104ZT			
C155	254 4302 958	CE04W1A470MT(SRE)			
C156 160	257 0512 903	CK73F1E104ZT			
C164	257 0512 903	CK73F1E104ZT			
C168	257 0512 903	CK73F1E104ZT			
C401,402	257 0512 903	CK73F1E104ZT			
C405 411	257 0512 903	CK73F1E104ZT			
C412	254 4302 958	CE04W1A470MT(SRE)			
C413 423	257 0512 903	CK73F1E104ZT			
C424	257 0509 929	CK73B1H102KT			
C425	254 4302 958	CE04W1A470MT(SRE)			
C430,431	257 0512 903	CK73F1E104ZT			
C432	254 4302 958	CE04W1A470MT(SRE)			
C433,434	257 0512 903	CK73F1E104ZT			
C436	254 4302 958	CE04W1A470MT(SRE)			
C441	257 0512 903	CK73F1E104ZT			
C442 444	257 0516 954	CK73B1E104KT			
C445	254 4299 964	CE04W1C470MT(SRE)			
C446	257 0516 954	CK73B1E104KT			
C501	257 0512 903	CK73F1E104ZT			
C502	254 4302 958	CE04W1A470MT(SRE)			
C503	257 0512 903	CK73F1E104ZT			
C504,505	257 0503 912	CC73CH1H9R0DT			
C506	257 0512 903	CK73F1E104ZT			
C507	257 0506 951	CC73CH1H101JT			
C508,509	254 4302 958	CE04W1A470MT(SRE)			
C510,511	257 0512 903	CK73F1E104ZT			
C512	254 4302 958	CE04W1A470MT(SRE)			
C513	257 0512 903	CK73F1E104ZT			
C514	254 4302 958	CE04W1A470MT(SRE)			
C515	254 4299 906	CE04W1C100MT(SRE)			
C516	257 0509 929	CK73B1H102KT			
C517 522	257 0512 903	CK73F1E104ZT			
C523	254 4302 958	CE04W1A470MT(SRE)			
C524	257 0512 903	CK73F1E104ZT			
C525	257 0501 901	CK73B1H103KT (1608)			
C526	257 0512 903	CK73F1E104ZT			
C529	254 4299 964	CE04W1C470MT(SRE)			
C530 532	257 0512 903	CK73F1E104ZT			
C534	254 4538 942	CE04W1C101MT SMG/RE3			
C601 603	257 0512 903	CK73F1E104ZT			
C604	254 4302 974	CE04W1A101MT(SRE)			
C605	257 0512 903	CK73F1E104ZT			
C606	254 4302 974	CE04W1A101MT(SRE)			
C607,608	257 0512 903	CK73F1E104ZT			
C609 614	257 0508 917	CC73CH1H471JT			
C615	257 0512 903	CK73F1E104ZT			
C621,622	254 4538 939	CE04W1C470MT SMG/RE3			
C623,624	254 4305 968	CE04W1H010MT(SRE)			
C659,660	257 0508 917	CC73CH1H471JT			
C663	257 0509 929	CK73B1H102KT			
C664	254 4536 928	CE04W1A101MT SMG/RE3			
C665	257 0501 901	CK73B1H103KT (1608)			
C666	257 0512 903	CK73F1E104ZT			

Ref.No.	Part No.	Part Name	Remarks	Q'ty	New
C667	254 4254 925	CE04W1C330MT (SME)			
C668	257 0501 901	CK73B1H103KT (1608)			
C671	257 0501 901	CK73B1H103KT (1608)			
C672	257 0512 903	CK73F1E104ZT			
C674	257 0512 903	CK73F1E104ZT			
C701,702	254 4538 900	CE04W1C100MT SMG/RE3			
C703,704	257 0503 925	CC73CH1H100DT			
C705,706	257 0512 903	CK73F1E104ZT			
C707,708	254 4541 900	CE04W1E100MT SMG/RE3			
C709,710	257 0509 929	CK73B1H102KT			
C740,741	254 4299 964	CE04W1C470MT(SRE)			
C748,749	257 0504 908	CC73CH1H220JT			
C750	257 0511 904	CK73F1H103ZT			
C751	257 0512 903	CK73F1E104ZT			
C752	257 0509 929	CK73B1H102KT			
C753	254 4302 958	CE04W1A470MT(SRE)			
C754	257 0512 903	CK73F1E104ZT			
C773	257 0508 917	CC73CH1H471JT			
C775,776	257 0509 961	CK73B1H152KT			
C786,787	257 0508 917	CC73CH1H471JT			
C790 792	257 0516 954	CK73B1E104KT			
C793,794	254 4538 900	CE04W1C100MT SMG/RE3			
C795	257 0516 954	CK73B1E104KT			
C796	254 4538 900	CE04W1C100MT SMG/RE3			
C797	257 0506 951	CC73CH1H101JT			
OTHER PARTS GROUP					
CX031	205 0343 032	3P CONN.BASE(KR PH)			
CX041	205 0343 045	4P CONN.BASE(KR PH)			
CX042	205 0321 041	4P CONNE.BASE(RED)			
CX101	205 0375 000	10P CON.BASE(KR PH)			
CX111	205 0375 013	11P CON.BASE(KR PH)			
CX401	205 0429 024	40P PIN HEADER			
FB601 603	235 0130 903	CHIP EMIFIL(11A121)			
FB651	235 0130 903	CHIP EMIFIL(11A121)			
JK601,602	204 8421 005	MINI JACK			
JK603	204 8664 008	3P PIN JACK			
JK604	204 8421 005	MINI JACK			
T651	231 8063 009	PULSE TRANS			
X151	399 0801 905	CSTCE8M00G52 RO			
X501	399 0794 009	X*TAL (32.00M)			
X701	399 0907 003	X*TAL(11.2896MHZ)			*

1U-3547 PANEL P.W.B. UNIT ASS'Y

Ref.No.	Part No.	Part Name	Remarks	Q'ty	New
SEMICONDUCTORS GROUP					
IC101	262 3048 007	ML9207 01GP			
IC102	262 3314 003	TMP86CM47U 4V14(PN3)			*
IC251,252	269 0203 008	GP1A70R			
IC901	265 0112 003	STR F6674			
IC902	262 3047 008	PC123 Y 22			
IC903	263 1113 005	SE005N			
TR101,102	271 0260 905	2SA1036KT146(S/R)			
TR104 107	269 0083 901	DTA114EKT96			
TR201 203	269 0083 901	DTA114EKT96			
D101 104	276 0559 909	DAP202KT146			
D901	276 0767 005	RBV 406			
D902	276 0730 906	AG01ZT (V1)			
D904 906	276 0730 906	AG01ZT (V1)			
D908	276 0784 004	FMB G14			
D909	276 0786 002	RN1Z			
D910	276 0787 001	RN2Z			
D911	276 0788 000	RN3Z			
D912	276 0769 003	RK 44			
D913	276 0785 906	AW04			
D914,915	276 0559 909	DAP202KT146			
ZD901	276 0760 989	MTZJ7.5B T77			
ZD902	276 0760 905	MTZJ3.6B T77			
LD101,102	393 9620 901	SMLU79423C(TP15)			
LD103 106	393 9604 901	SEL6227S(TP5)			
LD201	393 9608 907	SLR342MC(TB7)			
LD202,203	393 9604 901	SEL6227S(TP5)			
LD204,205	393 9605 900	SEL6427EP(TP5)			
LD206,207	393 9633 008	SELU1250CM(RED)			
LD208 210	393 9605 900	SEL6427EP(TP5)			
LD217	393 9605 900	SEL6427EP(TP5)			
LD218	393 9606 909	SEL6927A(TP5)			
LD253	393 9606 909	SEL6927A(TP5)			
LD254	393 9608 907	SLR342MC(TB7)			
LD256 258	393 9608 907	SLR342MC(TB7)			
LD259,260	393 9607 908	SLR342VC(TB7)			
TH901	279 0044 002	NTH11D8R0LA			
RESISTORS GROUP					
R901	244 2675 716	RS14B3D683JNBF (ERG)			
R902	244 2671 956	RS14B3DR47JNBST(S)			
R911	244 2675 716	RS14B3D683JNBF (ERG)	for E2		
VR251	211 5648 119	SLIDE VOLUME (100MM)			

Ref.No.	Part No.	Part Name	Remarks	Q'ty	New
CAPACITORS GROUP					
	C101,102	257 0509 929	CK73B1H102KT		
	C103 105	257 0512 903	CK73F1E104ZT		
	C106	257 0511 904	CK73F1H103ZT		
	C107	254 4193 947	CE04W1C101MT (SRA)		
	C108	257 0512 903	CK73F1E104ZT		
	C110	254 4302 958	CE04W1A470MT(SRE)		
	C111	257 0512 903	CK73F1E104ZT		
	C112	257 0501 901	CK73B1H103KT (1608)		
	C113	257 0512 903	CK73F1E104ZT		
	C114	257 0501 901	CK73B1H103KT (1608)		
	C116,117	257 0512 903	CK73F1E104ZT		
	C123 126	257 0511 920	CK73F1H473ZT		
	C127	257 0512 903	CK73F1E104ZT		
	C128	257 0511 904	CK73F1H103ZT		
	C129	257 0512 903	CK73F1E104ZT		
	C130	257 0511 904	CK73F1H103ZT		
	C131	257 0512 903	CK73F1E104ZT		
	C132	257 0511 904	CK73F1H103ZT		
	C133	257 0512 903	CK73F1E104ZT		
	C134	257 0511 904	CK73F1H103ZT		
	C135	257 0512 903	CK73F1E104ZT		
	C140,141	257 0511 904	CK73F1H103ZT		
	C143	257 0512 903	CK73F1E104ZT		
	C144	257 0511 904	CK73F1H103ZT		
	C201	257 0512 903	CK73F1E104ZT		
	C202	254 4302 958	CE04W1A470MT(SRE)		
	C204	257 0512 903	CK73F1E104ZT		
	C205	257 0511 904	CK73F1H103ZT		
	C206	257 0512 903	CK73F1E104ZT		
	C207	257 0511 904	CK73F1H103ZT		
	C208 212	257 0512 903	CK73F1E104ZT		
	C251	257 0512 903	CK73F1E104ZT		
	C254,255	257 0512 903	CK73F1E104ZT		
⚠	C261	253 8022 707	CK45F2EAC103MC		
⚠	C902	256 8038 017	CF99 2EAC224M		
⚠	C903	256 8038 004	CF99 2EAC104M		
	C904	254 4633 708	CE04W2D151MC(KMH)22S	for E3,JP	
	C904	254 4616 712	CE04W2G151MC(KMH)25C	for E2	
	C905	253 4546 724	CC45SL3D561JC		
	C906	253 4452 902	CC45SL1H471JT		
	C907	253 9030 963	CK45=1E103KT		
	C908	254 4423 905	CE04W1V470MT(KMG)		
⚠	C910	253 8029 700	CK45F2EAC222MC (KX)		
	C910	415 0866 006	CONDENSER COVER		
	C911	253 1118 906	CK45B1H332KT		
	C912	253 4546 724	CC45SL3D561JC		
	C913	254 4629 709	CE04W1C152MC(LXV)K25		
	C914	254 4632 709	CE04W1H471MC(LXV)K25		
	C915	254 4630 905	CE04W1E820MT(LXV)F11		
	C916	253 9031 904	CK45=1E473KT		
	C917	254 4628 904	CE04W1C331MT(LXV)H15		
	C918	254 4631 700	CE04W1E222MC(LXV)K40		
	C919	254 4538 939	CE04W1C470MT SMG/RE3		
	C922	254 4539 705	CE04W1C102MC SMG/RE3		
⚠	C923	253 8029 700	CK45F2EAC222MC (KX)		

Ref.No.	Part No.	Part Name	Remarks	Q'ty	New
OTHER PARTS GROUP					
	CW031	203 5280 039	3P KR DS CONN.CORD		
	CW041	203 6393 048	4P KR DS CON CORD		
	CW042	203 6393 022	4P KR DS CON CORD		
	CW091	204 2464 013	9P KR DS CONN.CORD		
	CW092	204 2464 026	9P KR DS CONN.CORD		
	CW101	204 2412 049	10P KR DS CONNE.CORD		
	CX021	205 0581 001	2P VH CONNECTOR BASE		
	CX042	205 0355 046	4P KR CON BASE(L)		
	CX091,092	205 0355 091	9P KR CON BASE(L)		
	CX911	205 0375 013	11P CON.BASE(KR PH)		
	CX941	205 0653 049	4P VH CON.BASE		
⚠	F901	206 1087 015	FUSE (ET1A)	for E3	
⚠	F901	206 1087 028	FUSE (ET2A)	for E2	
⚠	F901	206 1053 007	FUSE 1.0 A	for JP	
	FB901	235 0049 900	BEADS INDUCTOR TAPE		
	FF901	202 0040 909	FUSE CLIP (TAPE)		
	FH901	202 0040 909	FUSE CLIP (TAPE)		
	FL101	393 8063 006	FLT(24 ST 09GN)		
	L901	235 0157 009	PLA10AN7720R7D2B		
	L902	235 0156 903	COIL LHL10TB220KT		
	S101 109	212 5604 907	TACT SWITCH TA(ALPS)		
	S111 120	212 5604 907	TACT SWITCH TA(ALPS)		
	S122 124	212 5604 907	TACT SWITCH TA(ALPS)		
	S140	212 0410 002	ROTARY ENCODER JOG		
	S201 207	212 5604 907	TACT SWITCH TA(ALPS)		
⚠	S261	212 1176 015	POWER SWITCH(TV 5)		
⚠	T901	233 0654 001	SW TRANSFORMER		
	X101	399 0661 909	CSTS4.00MG06		
	X102	399 0805 901	CSTLS16M0X53 A0		
	AS901	417 0610 009	HEAT SINK(OSH 2430)		
		471 3305 027	3X10 CBS		
		415 0299 000	CONDENSER COVER	for E2, for C261	
		GEN 6256 2	FUSE LABEL SUB ASS'Y	for E2, for F901	
		GEN 6256 4	FUSE LABEL SUB ASS'Y	for JP, for F901	

EXPLODED VIEW

Parts List

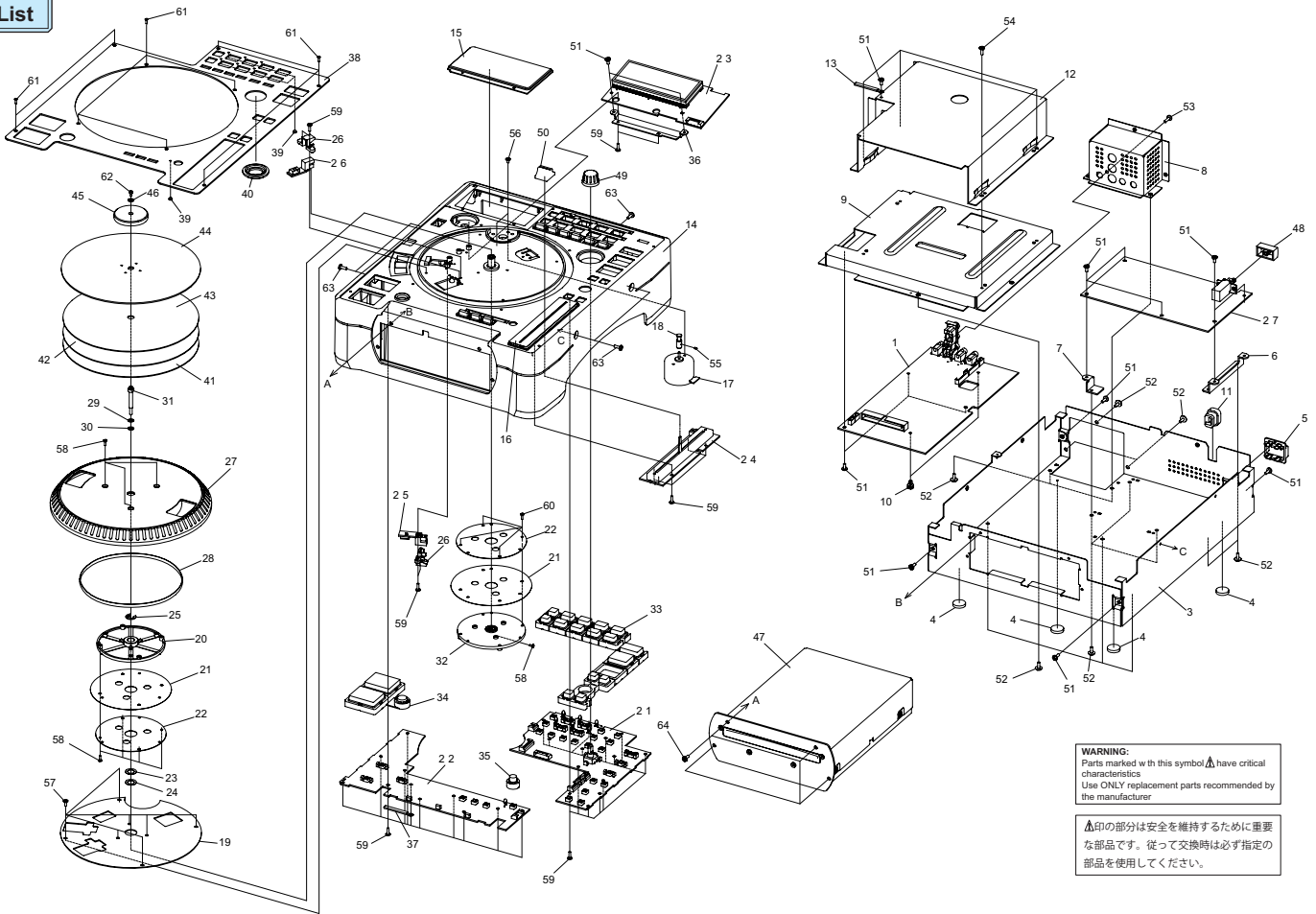

WARNING:
Parts marked with this symbol ⚠ have critical characteristics.
Use ONLY replacement parts recommended by the manufacturer.

⚠印の部分は安全を維持するために重要な部品です。従って交換時は必ず指定の部品を使用してください。

PARTS LIST OF EXPLODED VIEW

*本表に記載されている部品は、補修用部品のため製品に使用している部品とは一部、形状、寸法などが異なる場合があります。

Note: The symbols in the column "Remarks" indicate the following destinations.
 E3: U.S.A. & Canada model E2: Europe model
 JP: Japan model

Ref.No.	Part No.	Part Name	Remarks	Q'ty	New
1	GU 3546	DSP PWB UNIT		1	*
2	GU 3547	PANEL PWB UNIT		1	*
2 1		PANEL UNIT			
2 2		PANEL2 UNIT			
2 3		FLT UNIT			
2 4		SLIDE VR UNIT			
2 5		DISC SENSOR UNIT			
2 6		TABLE SENSOR UNIT			
2 7		POWER UNIT			
3	411 2027 210	CHASSIS		1	
4	461 0706 127	FOOT SHEET		4	
5	146 2302 002	P.SW KNOB GUIDE		1	
6	412 4921 003	PWB BRACKET		1	
7	412 5003 001	PWB SUPPORT		3	
8	412 5050 009	JACK BRACKET		1	*
9	412 5005 009	MAIN BRACKET		1	
10	412 2814 031	CARD SPACER (L=4)		2	
11	445 0084 009	CORD BUSH	for E3	1	
11	445 0056 008	CORD BUSH	for E2,JP	1	
12	412 5006 008	MECHA COVER		1	
13	445 0048 003	CORD HOLDER (L76)		1	
14	146 2303 218	INNER COVER ASS'Y		1	*
15	146 2305 119	WINDOW		1	*
16	146 2325 005	FADER PLATE		1	*
17	217 0181 006	LOADING MOTOR		1	
18	422 0670 106	MOTOR PULLY		1	
19	441 1974 006	BASE PLATE		1	
20	421 0798 001	PLATTER HOLDER		1	
21	421 0799 107	SCALE DISK		2	
22	441 1975 005	DISK FIX PLATE		2	
23	475 1187 003	WASHER 13/8.2		1	
24	475 1161 058	WASHER 8.2/12		1	
25	476 1006 006	6 E RING ZNP		1	
26	443 1573 005	S.COVER (GP1A70R)		2	
27	421 0815 007	PLATTER		1	*
28	423 0079 108	BELT		1	
29	475 1187 016	WASHER 7/4.1		1	
30	475 1161 016	WASHER		1	
31	422 0669 308	DISC HOLDER SHAFT		1	
32	421 0801 105	WHEEL ASS'Y		1	
33	119 0124 109	R.KEY (FUNCTION)		1	*
34	119 0119 305	R.KEY (PLAY/PAUSE)		1	
35	119 0120 103	R.KEY (PITCH)		1	
36	412 5007 007	FL BRACKET		1	
37	445 8028 009	CORD HOLDER		1	
38	144 2843 109	TOP PANEL		1	*
39	143 1163 007	LENS		7	
40	146 2306 008	KNOB (MARU) LENS		1	
41	421 0810 002	ANTI STATIC SHEET		1	
42	421 0809 000	SLIP SHEET		1	
43	421 0802 007	SLIP MAT		1	

	Ref.No.	Part No.	Part Name	Remarks	Q'ty	New
	44	421 0803 307	SLIP DISC		1	
	45	421 0820 005	STABILIZER (A)		1	*
	46	475 1187 029	WASHER 5/2.2		1	
	47	FG5 000	DRIVE UNIT		1	
	48	113 1689 001	P.SW KNOB		1	
	49	112 0902 016	KNOB (MARU)		1	*
	50	113 1951 014	FADER KNOB		1	*
	★ 71	204 6752 019	40P FLAT CABLE	CX401	1	
⚠ ⚠ ⚠	★ 72	203 6577 026	4P LC VH CON.CORD	CX941	1	
	★ 73	206 2155 001	AC CORD W/CON.E3	for E3	1	
	★ 73	206 2089 106	AC CORD W/CON.E2	for E2	1	
	★ 73	206 2085 003	AC CORD W/CON.DOM	for JP	1	
	★ 74	203 6596 007	4P PH CON CORD		1	
	★ 75	445 0033 005	WIRE CLAMP BAND		2	
	★ 76	204 6307 037	11P KR KR CON.CORD	CW911	1	
	★ 77	342 0027 000	FERRITE CORE		1	
	★ 78	415 0790 062	UL TUBE (14.3) BK	for E2,JP, for AC cord	1	
	★ 79	513 3870 021	RATING SHEET (E3)	for E3	1	*
	★ 79	513 3870 034	RATING SHEET (E2)	for E2	1	*
	★ 79	513 3906 018	RATING SHEET (J)	for JP	1	*
	★ 80	513 2303 007	VERSION LABEL		1	
	★ 81	513 1519 009	MANUFAC.DATE LABEL	for E3	1	
	★ 81	513 0985 003	INST LABEL	for E2	1	
	★ 82	513 3776 002	E3 LABEL	for E3	1	
	★ 82	513 2521 009	CE LABEL	for E2	1	
	★ 83	513 3384 009	C UL MARK US (813)	for E3	1	
	★ 83	513 3253 004	C TICK LABEL	for E2	1	
	★ 84	513 3159 001	FCC/CLASS B CAUTION	for E3	1	
SCREWS						
	51	473 7002 005	3X6 CBTS(S) Z		15	
	52	473 8007 083	3X8 CUP SCREW		14	
	53	473 7500 044	3X8 CBTS (P) B		1	
	54	473 7015 005	3X6 CBTS(S) B		4	
	55	474 4300 004	2.6X4 BSS (A)		1	
	56	471 3202 010	2.6X5 CBS		2	
	57	473 7505 010	2.6X6 CBTS (P) Z		7	
	58	471 3103 012	2X6 CBS		8	
	59	473 7505 007	2.6X8 CBTS (P) Z		34	
	60	473 7506 022	2X6 CBTS(P) B		4	
	61	473 8087 003	2X6 CFTS(B) B		9	
	62	475 5122 006	2X4 HSHB		1	
	63	473 7002 021	3X8 CBTS (S) B		5	
	64	471 1832 013	M3 SEMS SCREW(6W)		4	

EXPLODED VIEW OF CD DRIVE UNIT (FG-5000)

Parts List

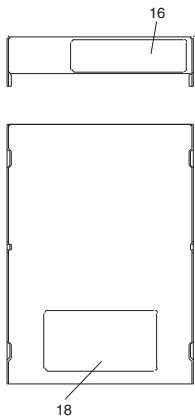
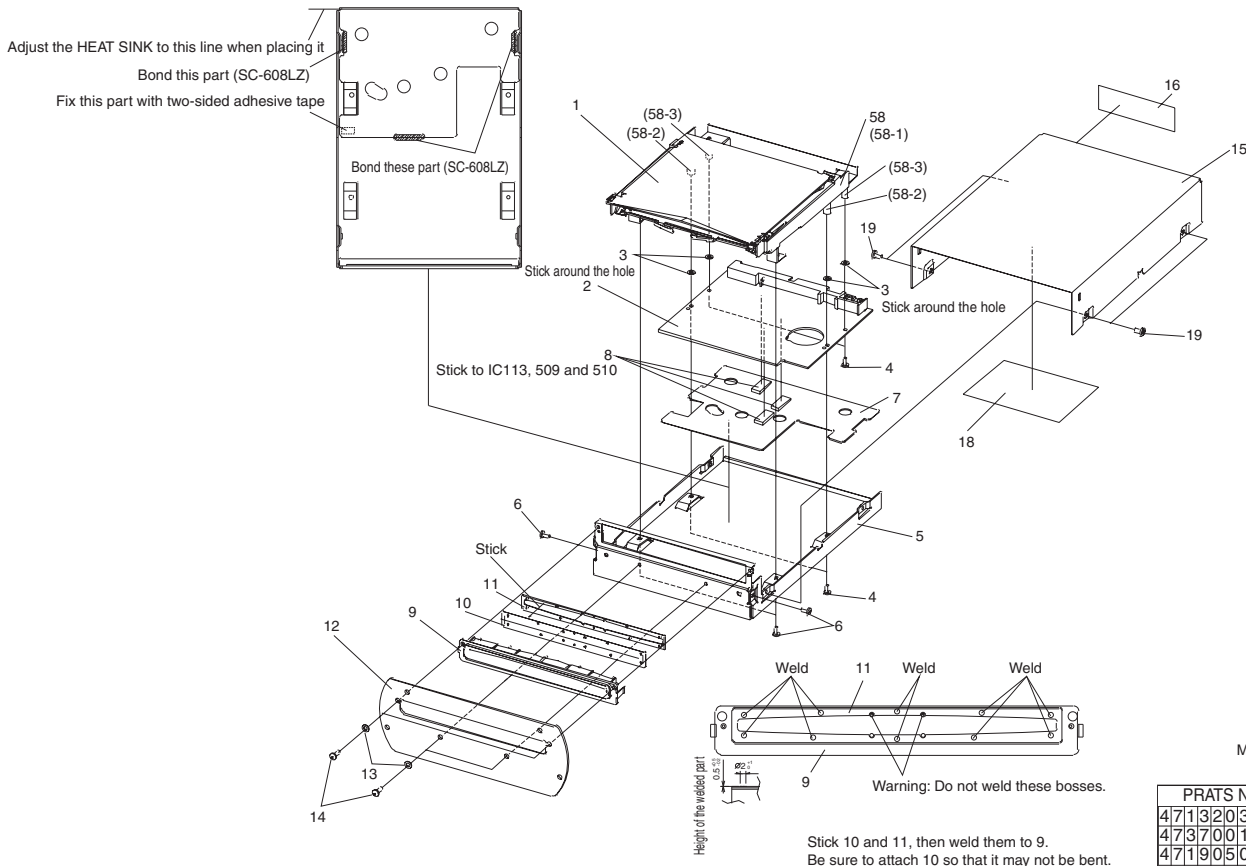

Maximum tightening torque of screws
(unit: Ncm)

PRATS NO.	PRATS NAME	T
47113203022	2.6X6 CBS-B	49
4737001035	2.6X6 CBTS(S)-Z	49
4719050033	3X8 FHHS MFZNI-B	59
4737002005	3X6 CBTS(S)-Z	108

PARTS LIST OF CD DRIVE UNIT (FG-5000)

*本表に記載されている部品は、補修用部品のため製品に使用している部品とは一部、形状、寸法などが異なる場合があります。

Ref.No.	Part No.	Part Name	Remarks	Q'ty	New
1	9KA 2A49 6A	CD MECHA ASS'Y	TD S202H2D	1	
2	GU 3414A	CD ROM PWB UNIT		1	
3	415 0900 001	PROTECT SHEET		4	
5	412 4997 008	DRIVE BRACKET		1	
7		HEAT SINK		1	
8	9KC 2G03 9A	HEAT PAD		3	
9	146 2296 309	DISC GUIDE		1	
10	415 0897 004	BLIND SHEET		1	
11	415 0898 003	FIX PLATE		1	
12	144 2816 107	DRIVE PANEL		1	
15	102 0657 018	DRIVE COVER		1	
16	513 3797 007	CONNECT LABEL		1	
18	513 3826 004	E2 LASER CAUTION		1	
58	441 1972 202	MAIN BASE ASS'Y		1	
58 1		MAIN BASE		1	
58 2		PWB SHAFT		2	
58 3		PWB SHAFT		2	
SCREWS					
4	471 3203 022	2.6X6 CBS B		4	
6	473 7001 035	2.6X6 CBTS (S) Z		4	
13	475 1178 009	3W B		4	
14	471 9050 033	3X8 FHHS MFZNII B		4	
19	473 7002 005	3X6 CBTS(S) Z		4	

EXPLODED VIEW OF CD MECHANISM

Parts List

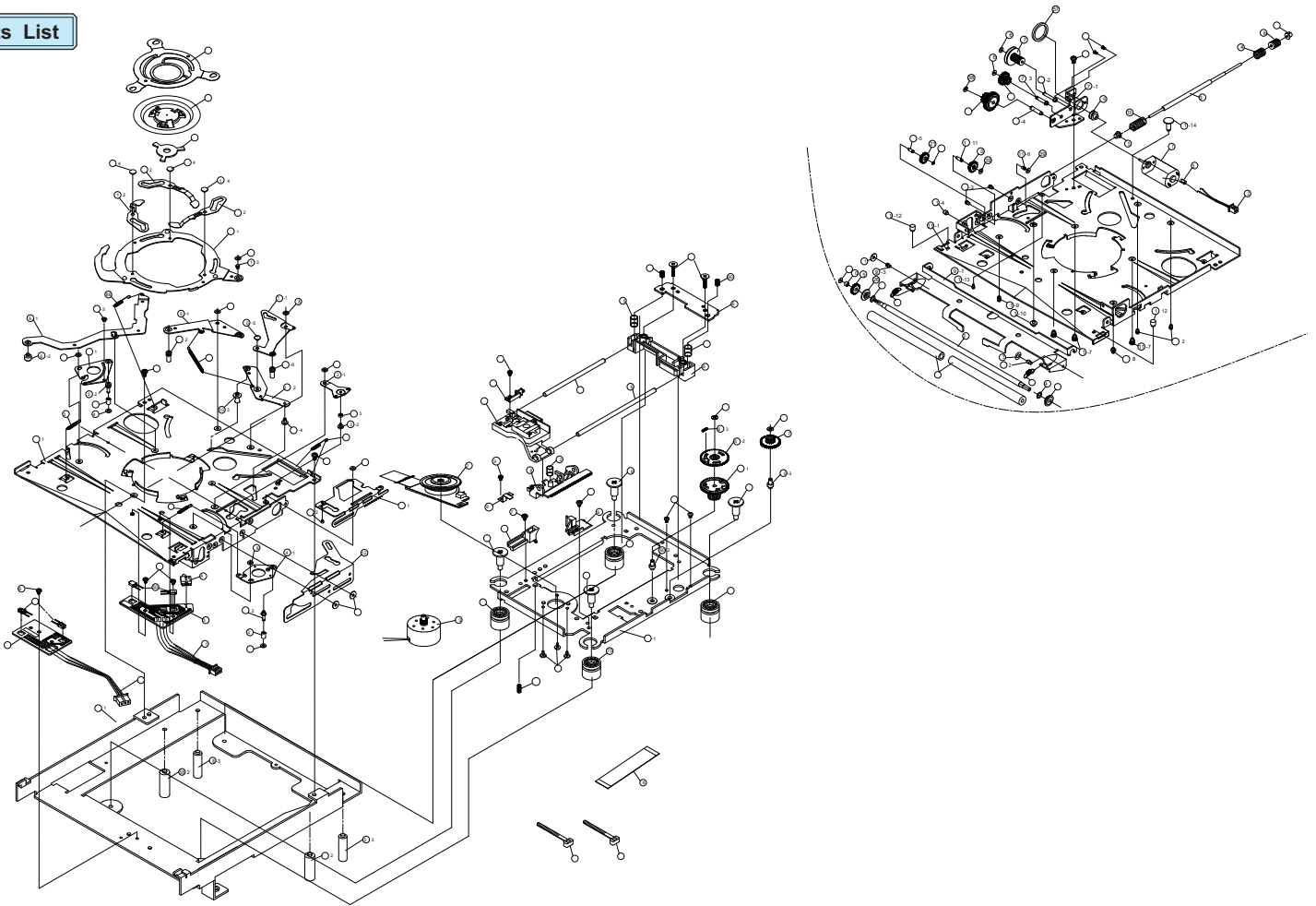

PARTS LIST OF CD MECHANISM UNIT (TD-S202SA(D))

*本表に記載されている部品は、補修用部品のため製品に使用している部品とは一部、形状、寸法などが異なる場合があります。

Ref. No.	Part No.	Part Name	Remarks	Q'ty	New	Ref. No.	Part No.	Part Name	Remarks	Q'ty	New
1	9KC 8A00 1	CLAMPER-PLATE ASSY		(1)		20	9KC 8G00 6	GEAR-LOAD-A		1	
1-1		CLAMPER-PLATE		1		21	9KC 8G00 7	IDLE-GEAR-ROLLER		1	
1-2		LIFTER-CAM		3		22	9KC 8G00 8	CHUCK-GEAR-A		1	
1-3		CL-PLATE-SFT		1		23	9KC 8G00 9	CHUCK-GEAR-B		1	
1-4		LIFTER-CAM-SFT		3		24	9KC 8G01 0	WORM-CHUCK		1	
2	9KC 8A00 2	TIMING-LEVER ASSY		(1)		25	9KC 8G01 1	SHAFT-CAP		2	
2-1		TIMING-LEVER		1		26	9KC 8G01 2	BERRING-ROLLER		2	
2-2		T-LEVER-SHAFT		1		27	9KC 8G01 3	CLAMPER		1	
2-3		T-LEVER-COLOR		1		28	9KC 8G01 4	DISC-OPEN-COLOR		2	
3	9KC 8A00 3	D-G-LEVER-L ASSY		(1)		29	9KC 8H02 8	ROLLER-SHAFT		1	
3-1		D-GUIDE-LEVER-L		1		30	9KC 8H02 9	ROLLER-COLOR		1	
3-2		DISC-OPEN-SFT-L		1		31	9KC 8H03 0	WORM-SHAFT		1	
3-3		CLP-GUIDE-SFT		1		32	9KC 8S00 6	ROLLER-SPRING		2	
4	9KC 8A00 4	D-G-LEVER-R ASSY		(1)		33	9KC 8S00 8	LEVER-SPRING		1	
4-1		D-GUIDE-LEVER-R		1		34	9KC 8S00 5	D-GUIDE-SP		2	
4-2		DISC-OPEN-SFT-R		1		38	9KP 16C3 25	PSW1.6X3.5X0.25C(BLACK)		7	
5	9KC 8A00 5	LINK-LEVER-L ASSY		(1)		39	9KP 12CR 32	PSW1.2X3.2X0.25C(RED)		3	
5-1		LINK-LEVER-L		1		40	9KC 8S00 7	C-LEVER-SPRING		1	
5-2		D-SELECT-SHAFT		1		41	9KP 16C5 04	PSW1.6X5X0.4C(BLACK)		3	
6	9KC 8A00 6	D-SELECT-LEVER ASSY		(1)		42	9KP 22W4 13	PSW2.2X4X0.13		2	
6-1		DISC-SELECT-LEVER		1		43	9KC 8P02 9	SPRING-WASHER		1	
6-2		D-SELECT-SFT-A		1		45	9KP 12C2 02	PSW1.2X2.0X0.25C		3	
7	9KC 8A00 7	GEAR-BASE ASSY		(1)		46	9KP 12C4 04	PSW1.2X4X0.4C		3	
7-1		GEAR-BASE		1		47	9KM 01T2 78	M1N10FB10K	MATSUSHITA	1	
7-2		TWIN-GEAR-SHAFT		1		48	9KS 01W2 05	ESE22MH23	MATSUSHITA	1	
7-3		C-GEAR-A-SHAFT		1		49	9KE 01L9 76	PT4800		2	
7-4		C-GEAR-B-SHAFT		1		50	9KE 01L9 75	GL4800	SHARP	2	
8	9KC 8A00 8	RACK-PLATE ASSY		(1)		51	9KC 8G03 6	CNW4P-TL-S		1	
8-1		RACK-PLATE		1		52	9KC 8G03 4	CNW2P-TL-S		1	
8-2		RACK-PLATE-SHAFT		1		53	9KC 8G03 5	CNW3P-TL-S		1	
9	9KC 8A00 9	ROLLER-BASE ASSY		(1)		54	9KC 5G02 2	∅2.5X3 TUBE(BLACK)		1	
9-1		ROLLER-BASE		1		55	9KC 8P01 7	SW-PCB		1	
9-2		R-B-SHAFT-L		1		56	9KC 8G03 2	ROLLER		2	
9-3		R-B-SHAFT-R		1		57	9KC 8G01 7	LOADING BELT-L		1	
10	9KC 8A01 0	LINK-CHANGE ASSY		(1)		58	9KA 2A47 9	MAIN BASE ASSY		(1)	*
10-1		LINK-LEVER-R		1		58-1		MAIN BASE		1	
10-2		CHANGE-LEVER		1		58-2		PWB SHAFT		2	
10-3		C-LEVER-SFT-A		1		58-3		PWB SHAFT		2	
10-4		C-LEVER-SFT-B		1		59	9KC 8P01 9	SENSOR-PCB		1	
10-5		C-LEVER-SFT-C		1			9KC 7A00 7A	TRAVERSE UNIT(FEED)ASSY	60 74 77 81, 83,84,93 95Assy	(1)	
10-6		D-SELECT-SHAFT		1			9KC 7A00 8A	TRAVERSE UNIT ASSY	60 72,74,77 81, 83,84,93 95Assy	(1)	
11	9KC 8A01 5	LOADER-BASE ASSY		(1)		60		CHASSIS-PU-TDT ASSY		(1)	
11-1		LOADER-BASE		1		60-1		CHASSIS-PU-TDT		1	
11-2		LEVER-SHAFT		2		60-2		SFT-G-2ND-84M		1	
11-3		CAM-SHAFT		2		60-3		SFT-G-3RD-2MP		1	
11-4		CAM-GUIDE-SFT		1		61		HLD-SFT-L-84H		1	
11-5		ROLLER-GEAR-SFT		1		62		HLD-SFT-R-84H		1	
11-6		L-P-GUIDE-SFT-A		1		63		BASE TILT-84H		1	
11-7		CLAMP-GUIDE-SFT		3		64		PLATE TILT-84H		1	
11-8		D-G-A-SHAFT-L		1		65		TILT SP		2	
11-9		D-G-A-SHAFT-R		1		66		RAIL		1	
11-10		TIMING-LVR-SFT-N		1		67		S-GUIDE BAR-84H		1	
11-11		GEAR-LOAD-SFT		1		68		RACK PU-84H		1	
11-12		D-G-SHAFT		2		69		GEAR 2ND ASSY		(1)	
11-13		L-P-GUIDE-SFT-B		1		69-1		GEAR 2nd(A)		1	
11-14		EJECT-GUIDE-SFT		1		69-2		GEAR 2nd(B)		1	
12	9KC 8P01 4	CAM-R		1		69-3		SPG GEAR 2ND		1	
13	9KC 8P01 5	CLAMPER-TOP		1		70		PICK UP HOP-1200R		1	
14	9KC 8P01 6	CLAMPER-YOKE		1		71		SPG PICK-84H		1	
15	9KC 8G00 1	ROLLER-GEAR		1		72		SPG RACK-84H		1	
16	9KC 8G00 2	MOTOR-PULLY		1		73		MOTOR FEED-2HP ASSY		(1)	
17	9KC 8G00 3	PULLY-GEAR		1		73-1		MDN3BL4FPQ		1	
18	9KC 8G00 4	HERICAL-GEAR		1		73-2		GEAR 1ST 2MP		1	
19	9KC 8G00 5	WORM-LOAD		1		73-3		PSW1.95X3.5X0.25		1	

Ref. No.	Part No.	Part Name	Remarks	Q'ty	New
74		T/T MOTOR ASSY		(1)	
74-1		TABLE-M32		1	
74-2		MAGNET-M32		1	
74-3		RUBBER-M32		1	
74-4		BACK YOKE-M32		1	
74-5		T.T BUSH-SLOT-NI		1	
74-6		BML5E7CRS		1	
75	9KC 2G08 3	DAMPER IDLE		4	
76	9KC 1H01 1	SCW-DAMPER		4	
77		GEAR 3rd 2MP		1	
81		PSW2.1X4X0.25C		2	
86	9KC 8S00 9	LEVER-SPRING-S		1	
88	9KC 2P11 4	FFC-0.5-24P L60		1	
91	9KM 01N1 22	NYLON BAND 80		2	
94		SPRING-RAIL-84H		1	

Ref. No.	Part No.	Part Name	Remarks	Q'ty	New
SCREWS					
35	9KS 14N1 02	M1.4X2 PRECISION SCREW	TYPE-1	2	
36	9KS 20N3 03	M2X3 PRECISION SCREW	TYPE-3	1	
37	9KS 17N0 15	M1.7X1.5 PRECISION SCREW	TYPE-3	2	
78	9KB 26TK 06	M2.6X6 SCREW	S	2	
79	9KH 26TK 15	M2.6X15 SCREW	S	2	
80	9KB 7H00 8	M3X4 SCREW		2	
82	9KB 20TK 04	M2X4 SCREW	S	3	
83	9KS 17B3 05	M1.7X5 PRECISION SCREW	B TYPE-3	1	
84	9KS 17N0 22	M1.7X2.2 PRECISION SCREW	TYPE-3	5	
93	9KB 26TK 04	M2.6X4 SCREW	S	1	
95	9KC 2H00 4	M3X8 HEXAGON S. S. SCREW		1	

PACKING VIEW

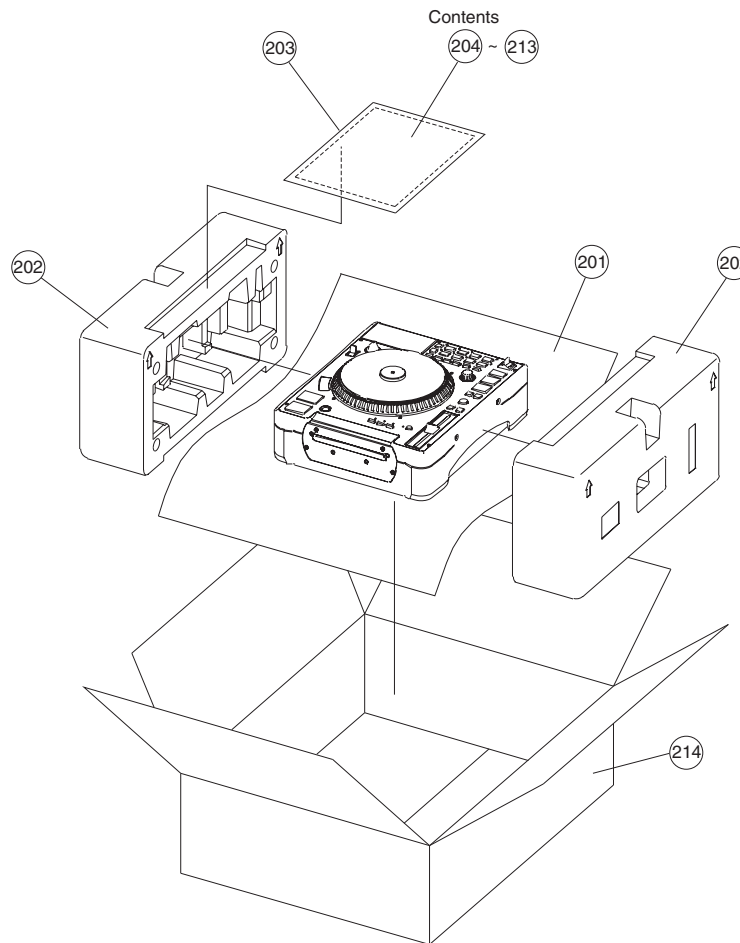

PARTS LIST OF PACKING & ACCESSORIES

*本表に記載されている部品は、補修用部品のため製品に使用している部品とは一部、形状、寸法などが異なる場合があります。

Note: The symbols in the column "Remarks" indicate the following destinations.

E3: U.S.A. & Canada model

E2: Europe model

JP: Japan model

	Ref.No.	Part No.	Part Name	Remarks	Q'ty	New
	201	505 0350 019	STYLEN PAPER		1	
	202	503 1448 005	CUSHION		2	
	203	505 0038 030	POLY COVER		1	
	204	515 0945 007	WARRANTY (COM.)	for E3	1	
	205	511 4086 009	INST. MANUAL	for E3,E2	1	*
	205	511 4111 000	INST. MANUAL (J)	for JP	1	*
	206	515 0923 207	S.S.LIST COM.(EX)	for E3,E2	1	
	206	515 0918 102	SERVICE STATION LIST	for JP	1	
	207	203 2360 004	2P PIN CORD		1	
	208	505 8006 006	ENVELOPE		2	
	209	421 0819 003	ADAPTOR		1	*
	210	473 7507 021	2X4 CBTS (P) B		3	
	211	423 0079 108	BELT		1	
	212	529 0128 001	HEXAGON WRENCH		1	
	213	475 1187 029	WASHER 5/2.2		1	
	214	501 2179 076	CARTON CASE		1	*
	★ 215		CONTROL CARD		2	
	★ 216		BAR CODE LABEL		1	
	★ 216	998 0005 304	POS LABEL	for JP	1	*
	★ 217	GEN 6377	RECYCLING LABEL	for JP	1	
	★ 218	515 0919 004	GUARANTEE CARD(S)	for JP	1	

WIRING DIAGRAM

DN-S3000 SINGLE CD PLAYER WIRING DIAGRAM

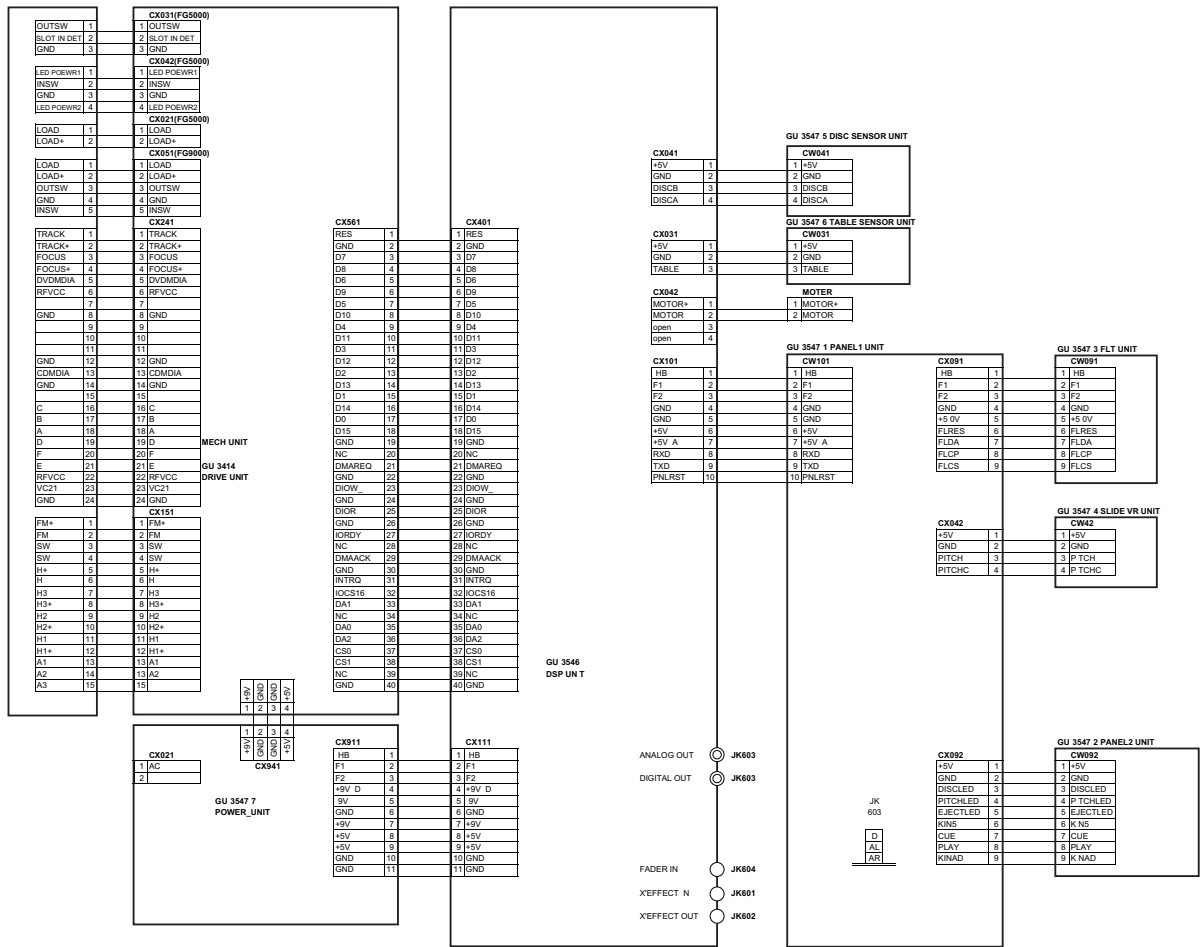

NOTE FOR SCHEMATIC DIAGRAM

WARNING:

Parts marked with this symbol  have critical characteristics. Use ONLY replacement parts recommended by the manufacturer.

CAUTION:

Before returning the unit to the customer, make sure you make either (1) a leakage current check or (2) a line to chassis resistance check. If the leakage current exceeds 0.5 milliamps, or if the resistance from chassis to either side of the power cord is less than 460 kohms, the unit is defective.

WARNING:

DO NOT return the unit to the customer until the problem is located and corrected.

NOTICE:

ALL RESISTANCE VALUES IN OHM. k 1,000 OHM
M 1,000,000 OHM

ALL CAPACITANCE VALUES IN MICRO FARAD.

P MICRO-MICRO FARAD

EACH VOLTAGE AND CURRENT ARE MEASURED AT
NO SIGNAL INPUT CONDITION.

CIRCUIT AND PARTS ARE SUBJECT TO CHANGE
WITHOUT PRIOR NOTICE.

配線図について

印の部品は安全を維持するために重要な部品です。従って交換時は必ず指定の部品を使用してください。

注)

- (1) 指定なき抵抗値は Ω 、k は $k\Omega$ 、M は $M\Omega$ を示す。
- (2) 指定なきコンデンサーの値は μF 、p は pF を示す。
- (3) 各部の電圧は無信号の値を示す。
- (4) この配線図は基本配線図です。改良等のため変更することがありますのでご了承ください。

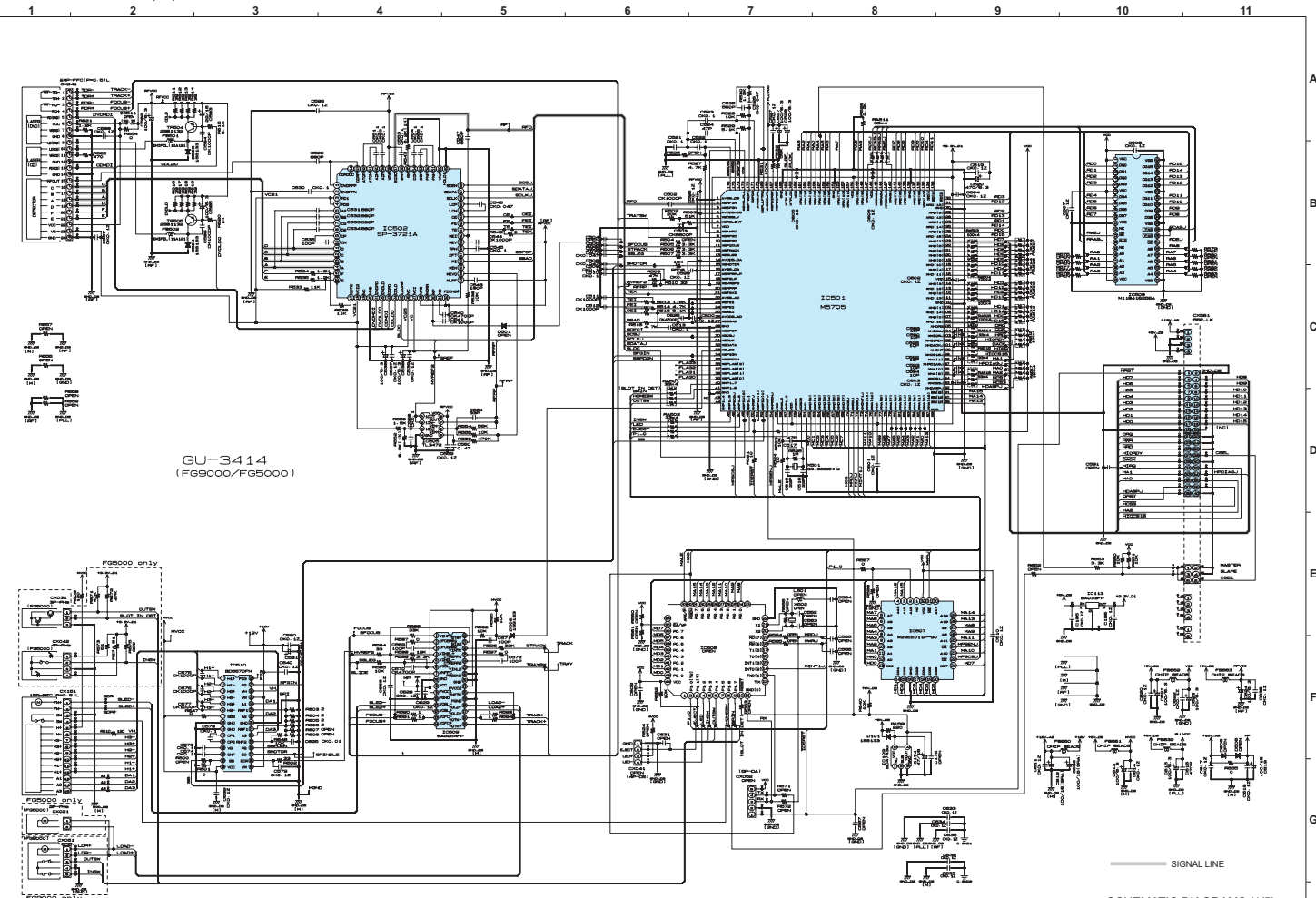

GU-3414
(FG9000/FG5000)

SCHEMATIC DIAGRAMS (1/5)
GU 3414 CD ROM UNIT

SCHEMATIC DIAGRAMS (2/5)

1 2 3 4 5 6 7 8 9 10 11

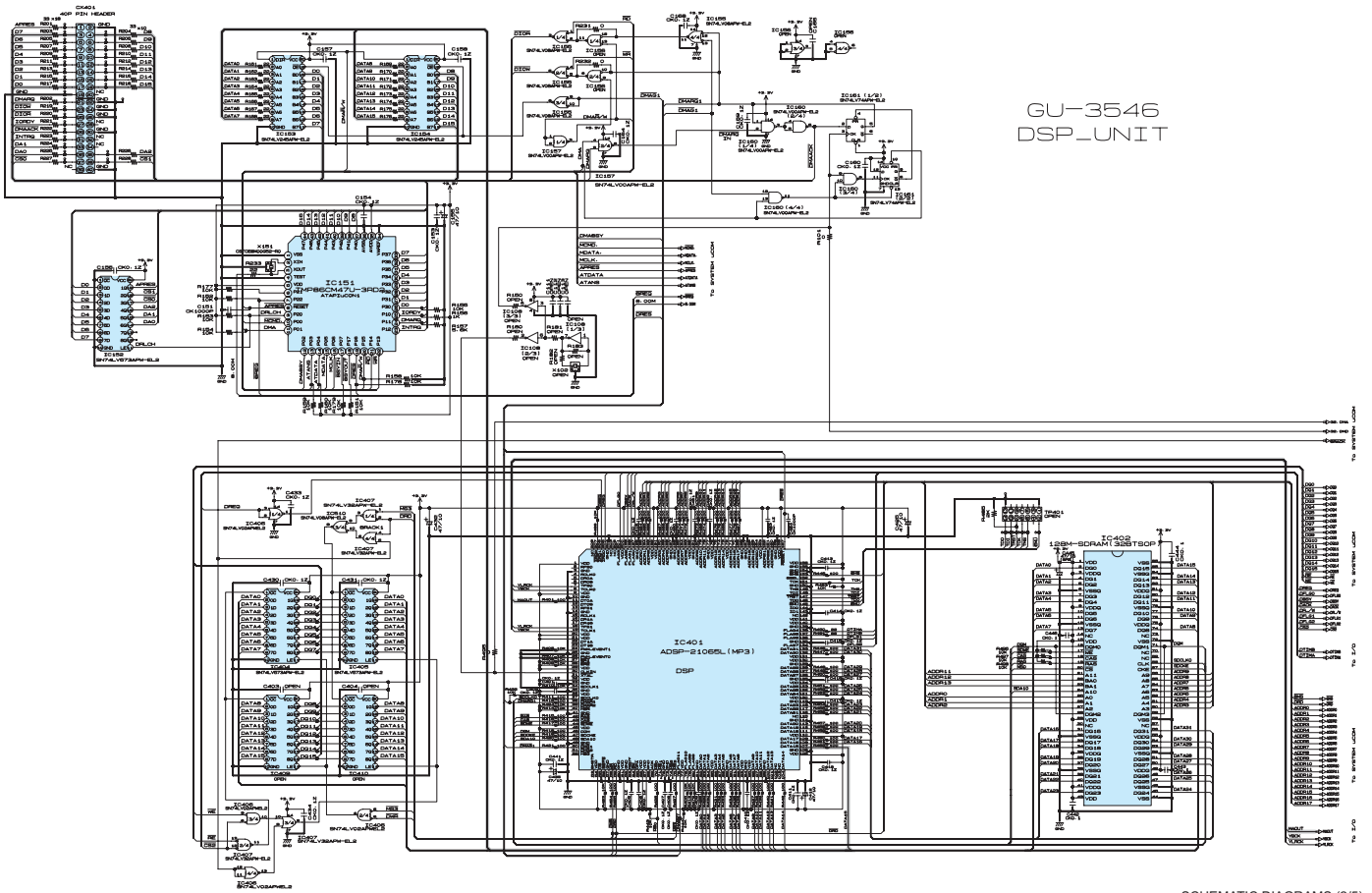

GU-3546
DSP_UNIT

— SIGNAL LINE SCHEMATIC DIAGRAMS (2/5)
GU 3546 DSP UNIT (1/2)

1 2 3 4 5 6 7 8 9 10 11

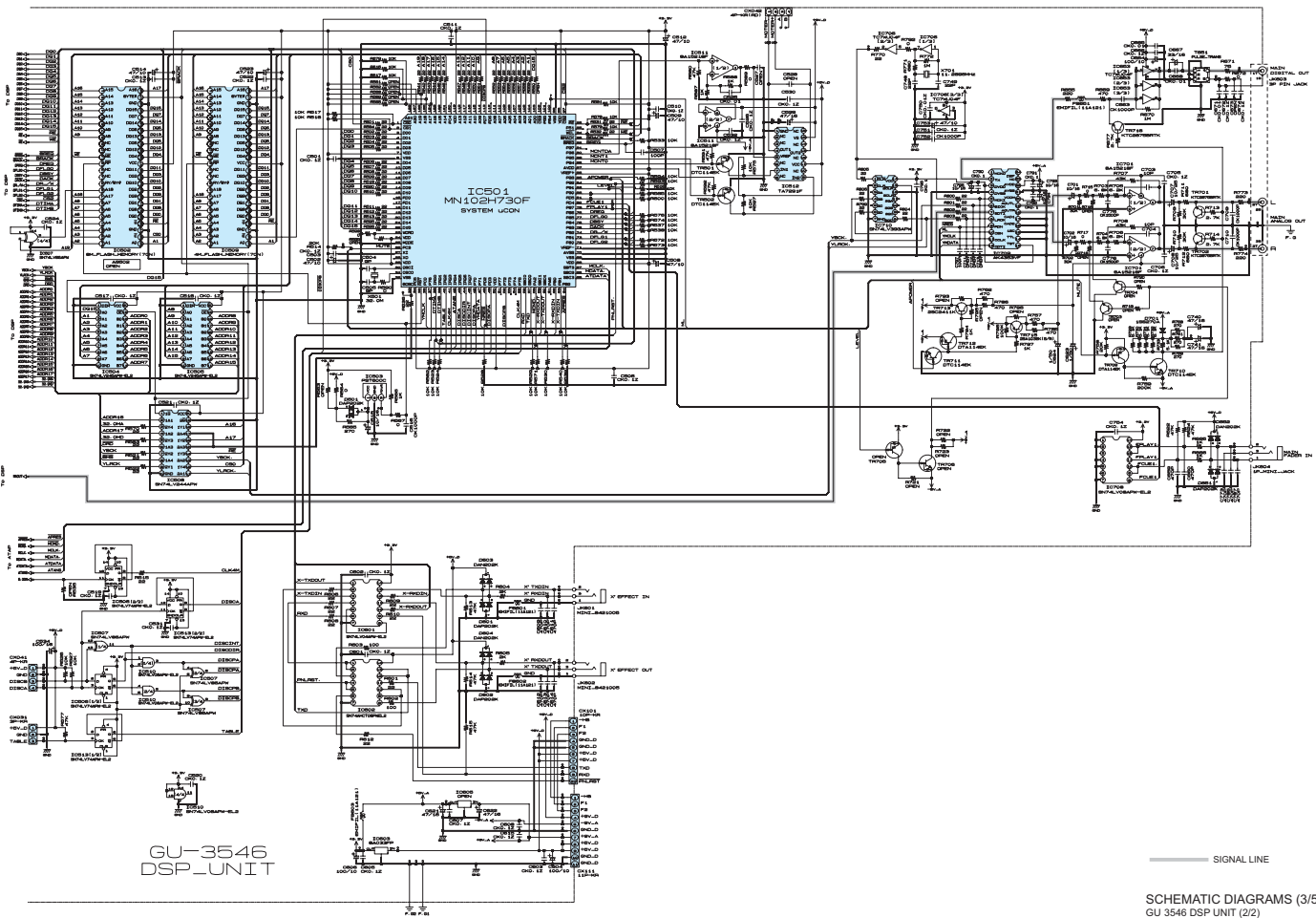

GU-3546
DSP_UNIT

A
B
C
D
E
F
G
H

1 2 3 4 5 6 7 8 9 10 11

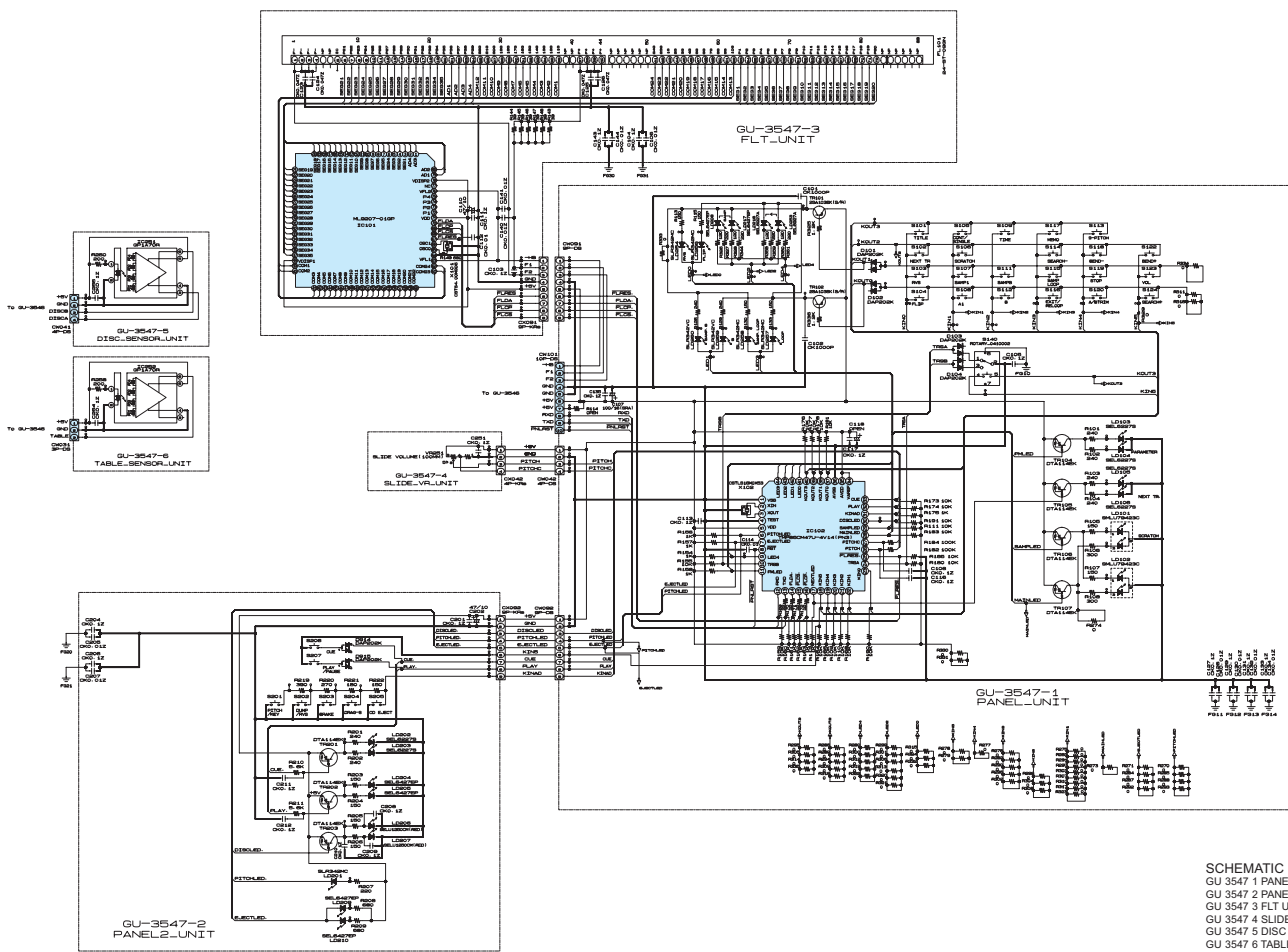

SCHEMATIC DIAGRAMS (4/5)
 GU 3547 1 PANEL UNIT
 GU 3547 2 PANEL2 UNIT
 GU 3547 3 FLT UNIT
 GU 3547 4 SLIDE VR UNIT
 GU 3547 5 DISC SENSOR UNIT
 GU 3547 6 TABLE SENSOR UNIT

A
B
C
D
E
F
G
H

1 2 3 4 5 6 7 8 9 10 11

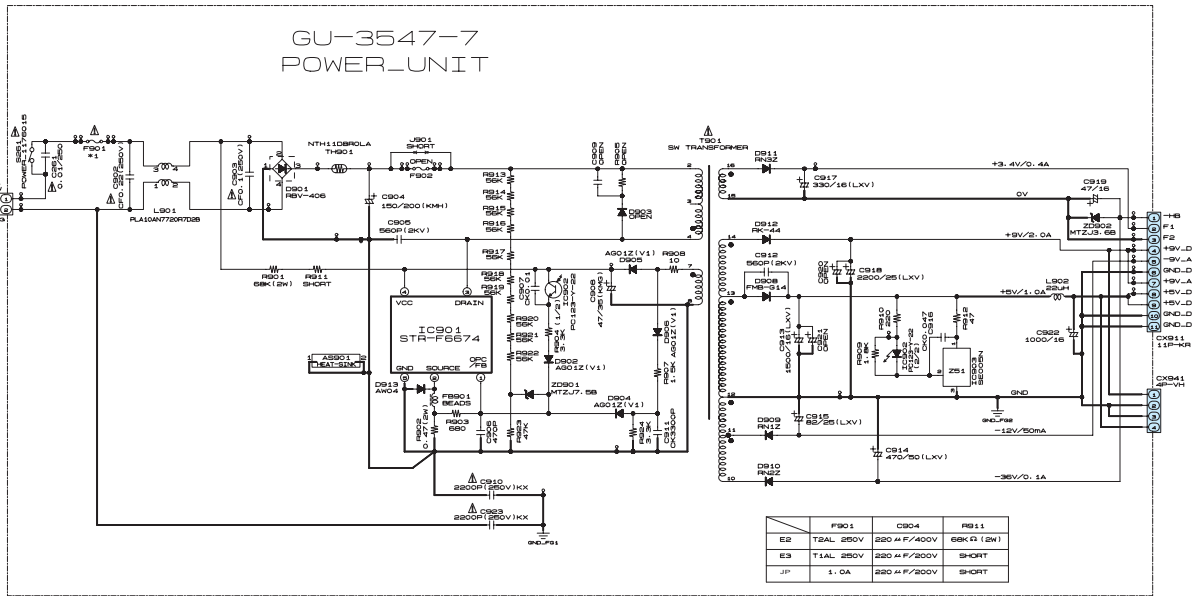

SCHEMATIC DIAGRAMS (5/5)
GU 3547 7 POWER UNIT