

DENON

For U.S.A., Canada, Europe, U.K.,
Asia, China, Taiwan R.O.C., Korea
& Japan model

Ver. 1

SERVICE MANUAL

MODEL DN-X100

DJ MIXER

注意

サービスをおこなう前に、このサービスマニュアルを必ずお読みください。本機は、火災、感電、けがなどに対する安全性を確保するために、さまざまな配慮をおこなっており、また法的には「電気用品安全法」にもとづき、所定の許可を得て製造されております。従ってサービスをおこなう際は、これらの安全性が維持されるよう、このサービスマニュアルに記載されている注意事項を必ずお守りください。

● For purposes of improvement, specifications and design are subject to change without notice.

● 本機の仕様は性能改良のため、予告なく変更することがあります。
● 補修用性能部品の保有期間は、製造打切後8年です。

● Please use this service manual with referring to the operating instructions without fail.

● 修理の際は、必ず取扱説明書を参照の上、作業を行ってください。

● Some illustrations using in this service manual are slightly different from the actual set.

● 本文中に使用しているイラストは、説明の都合上現物と多少異なる場合があります。

DENON, Ltd.

TOKYO, JAPAN

SAFETY PRECAUTIONS

The following check should be performed for the continued protection of the customer and service technician.

LEAKAGE CURRENT CHECK

Before returning the unit to the customer, make sure you make either (1) a leakage current check or (2) a line to chassis resistance check. If the leakage current exceeds 0.5 milliamps, or if the resistance from chassis to either side of the power cord is less than 460 kohms, the unit is defective.

注意

サービス、点検時には次のことにご注意願います。

●注意事項をお守りください！

サービスのとき特に注意を必要とする個所については、キャビネット、部品、シャーシなどにラベルや捺印で、注意事項を表示しています。これらの注意書きおよび取扱説明書などの注意事項を必ずお守りください。

●感電に注意！

- (1) このセットは、交流電圧が印加されていますので、通電時に内部金属部に触れると感電することがあります。従って通電サービス時には、絶縁トランスの使用や手袋の着用、部品交換には、電源プラグを抜くなどして、感電にご注意ください。
- (2) 内部には、高電圧の部分がありますので、通電時の取扱には、十分ご注意ください。

●指定部品の使用！

セットの部品は難燃性や耐電圧など安全上の特性を持ったものとなっています。従って交換部品は、使用されていたものと同じ特性の部品を使用してください。特に配線図、部品表に△印で指定されている安全上重要な部品は必ず指定のものをご使用ください。

- ### ●部品の取付けや配線の引きまわしは、元どおりに！
- 安全上、テープやチューブなどの絶縁材料を使用したり、プリント基板から浮かして取付けた部品があります。また内部配線は引きまわしやクランプによって発熱部品や高圧部品に接近しないように配慮されていますので、これらは必ず元どおりにしてください。

●サービス後は安全点検を！

サービスのために取り外したねじ、部品、配線などが元どおりになっているか、またサービスした個所の周辺を劣化させてしまったところがないかなどを点検し、外部金属端子部と、電源プラグの刃の間の絶縁チェックをおこなうなど、安全性が確保されていることを確認してください。

(絶縁チェックの方法)

電源コンセントから電源プラグを抜き、アンテナや、プラグなどを外し、電源スイッチを入れます。500V絶縁抵抗計を用いて、電源プラグのそれぞれの端子と、外部露出金属部〔アンテナ端子、ヘッドホン端子、マイク端子、入力端子など〕との間で、絶縁抵抗値が1MΩ以上であること、この値以下のときは、セットの点検修理が必要です。

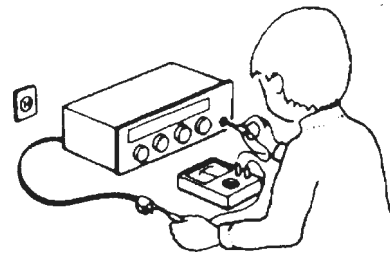

注意 安全上重要な部品について

本機に使用している多くの電気部品、および機構部品は安全上、特別な特性を持っています。この特性はほとんどの場合、外観では判別つきにくく、また、もとの部品より高い定格（定格電力、耐圧）を持ったものを使用しても安全性が維持されるとは、限りません。安全上の特性を持った部品は、このサービスマニュアルの配線図、部品表につきのように表示していますので、必ず指定されている部品番号のものを使用願います。

(1) 配線図… △マークで表示しています。

(2) 部品表… △マークで表示しています。
指定された部品と異なるものを使用した場合には、感電、火災などの危険を生じる恐れがあります。

DISASSEMBLY

(Follow the procedure below in reverse order when reassembling.)

1. Top Panel

- (1) Pull out the Knobs from the Top Panel.
- (2) Remove the 6 screws attaching the Top Panel.
- (3) Pull up the Top Panel.

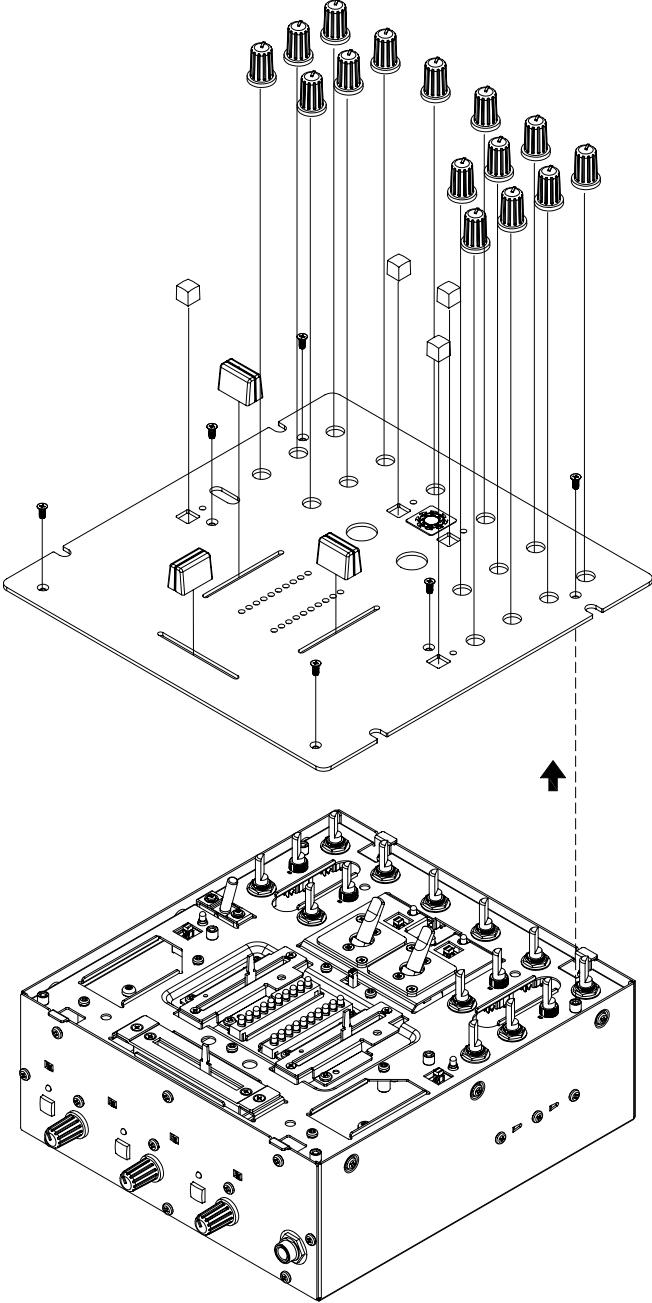

2. Crossfader Unit

- (1) Remove the 2 screws attaching the Crossfader Unit.
- (2) Pull up the Crossfader Unit and disconnect the connector.

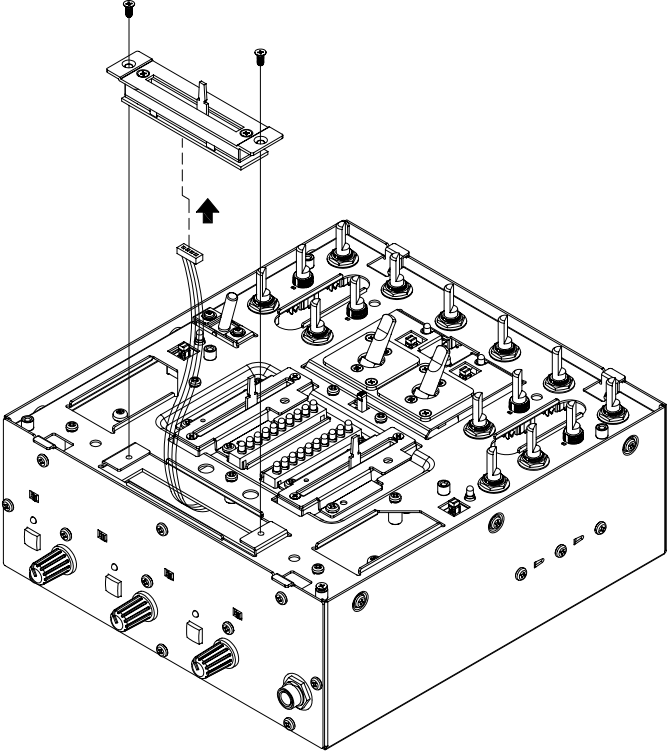

Note:
● Be careful in the attachment direction.

3. Channel Fader Unit

- (1) Remove the 3 screws attaching the Channel Fader Unit.
- (2) Pull up the Channel Fader Unit and disconnect the connector.

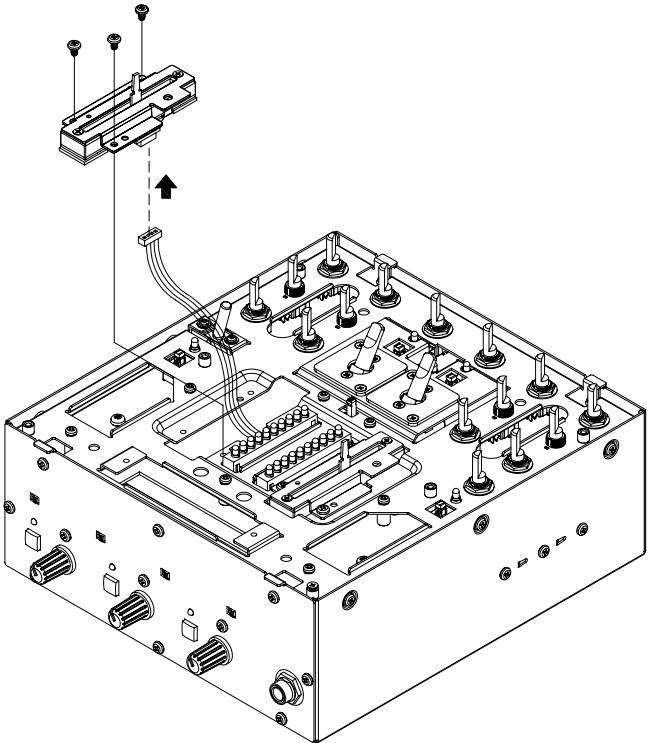

4. Input Selector Unit

- (1) Remove the 2 screws attaching the Input Selector Unit.
- (2) Pull up the Input Selector Unit and disconnect the connector.

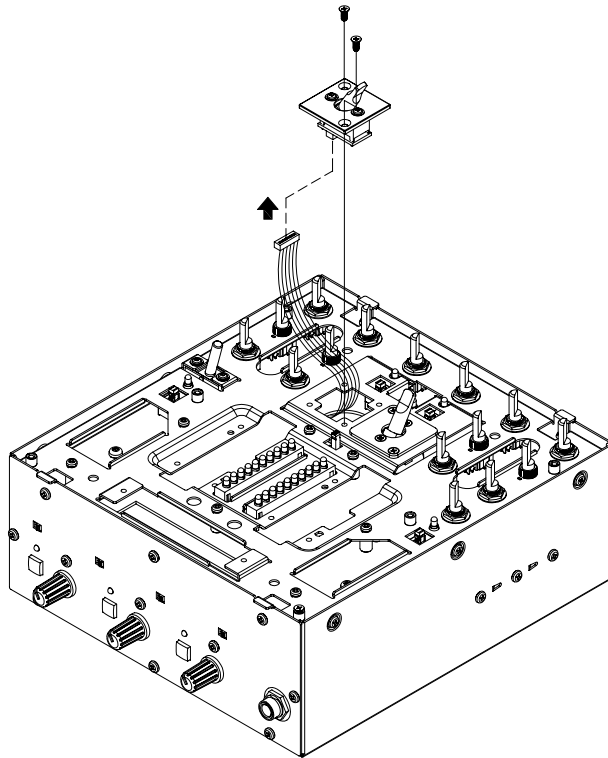

Note:

- Be careful in the attachment direction.

5. Top Panel Unit

- (1) Remove the 6 screws from the both-sides side.
- (2) Remove the 2 screws from the rear side.
- (3) Remove the 5 screws from the front side.
- (4) Remove the 4 screws from the bottom side.
- (5) Pull up the front side of the Top Unit.
- (6) Disconnect the connectors.

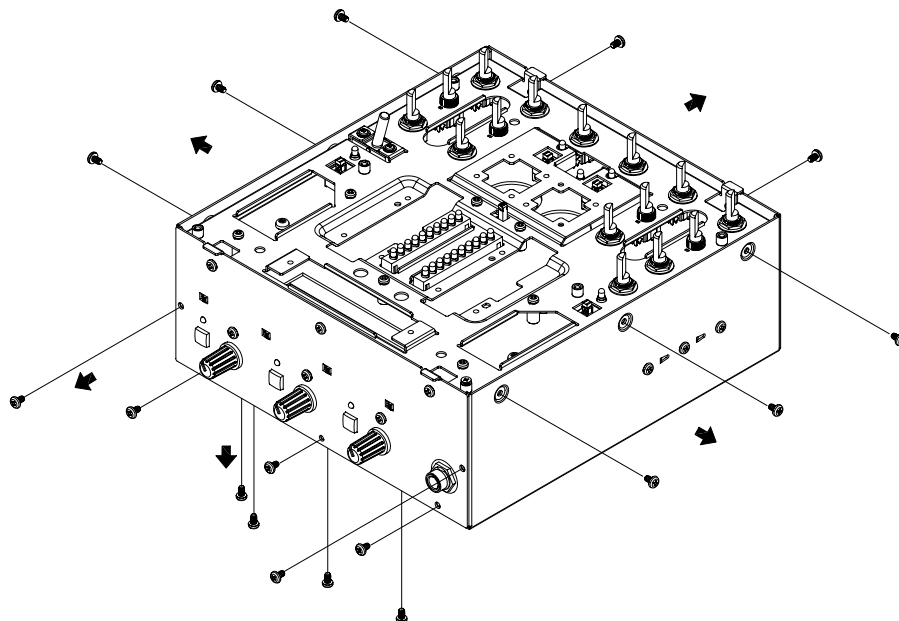

BLOCK DIAGRAM

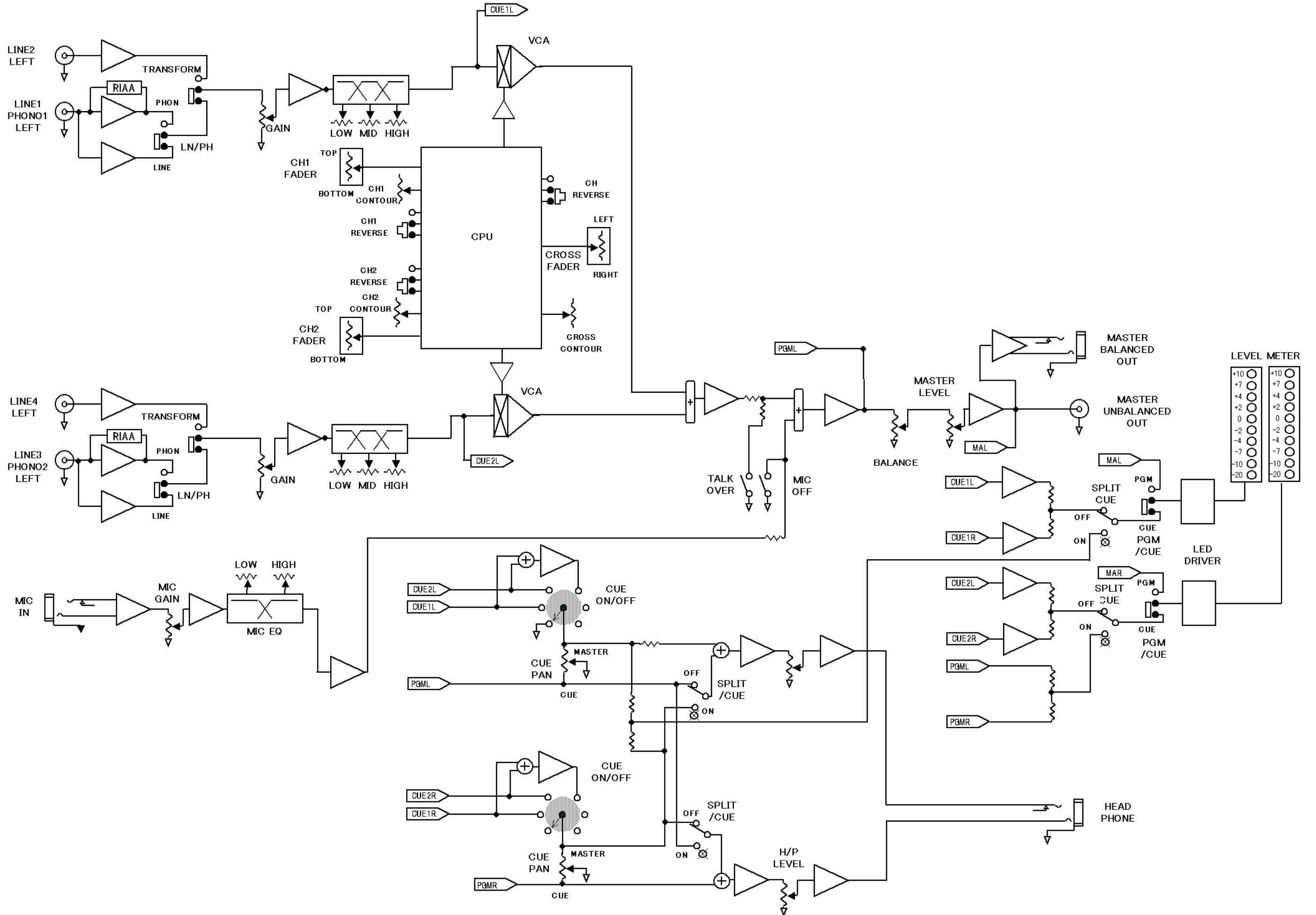

SEMICONDUCTORS

Only major semiconductors are shown, general semiconductors etc. are omitted to list.
 主な半導体を記載しています。汎用の半導体は記載を省略しています。

1. IC's

MAX003 (IC801)

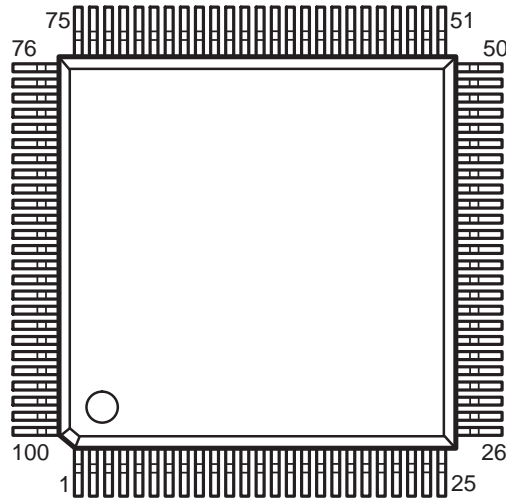

MAX003 Terminal Function

Pin No.	Pin Name	Symbol	I/O	Det	Int Pu	Ext	Res	Ini	Function
1	VCL	VCL	-	-	-	-	-	-	VCL(capacitor between this pin and GND)in 5V operation models,and as Vcc in 3V operation models.
2	PB0	CH1FS	I	-	-	Pu	L	H	CH1 FADER START SW 'L' : ON
3	PB1	PB1	O	-	-	Pu	L	L	Not used
4	PB2	PB2	O	-	-	Pu	L	L	Not used
5	PB3	PB3	O	-	-	Pu	L	L	Not used
6	PB4	PB4	O	-	-	Pu	L	L	Not used
7	PB5	PB5	O	-	-	Pu	L	H	Not used
8	PB6	FX2SW	I	-	-	Pu	L	H	PGM2 EFFECT LOOP ON/OFF SW 'L' : ON (DN-X300 only)
9	PB7	CHREV	I	-	-	Pu	L	H	CH REVERSE SW 'L' : ON
10	_RESO	_RESO	O	-	-	-	-	-	Not used
11	Vss	Vss	-	-	-	-	-	-	GND(0V)
12	P90	P90	O	-	-	-	L	L	Not used
13	P91	P91	O	-	-	-	L	L	Not used
14	P92	P92	O	-	-	-	L	L	Not used
15	P93	P93	O	-	-	-	L	L	Not used
16	P94	P94	O	-	-	-	L	L	Not used
17	P95	P95	O	-	-	-	L	L	Not used
18	P40	P40	O	-	ON	-	L	L	Not used
19	P41	P41	O	-	ON	-	L	L	Not used
20	P42	P42	O	-	ON	-	L	L	Not used
21	P43	PC1A	I/O	-	ON	-	L	H	PGM1 Fader PLAY output 30msec 'L' pulse
22	Vss	Vss	-	-	-	-	-	-	GND(0V)
23	P44	PC1B	I/O	-	ON	-	L	H	PGM1 Fader CUE output 30msec 'L' pulse
24	P45	PC2A	I/O	-	ON	-	L	H	PGM2 Fader PLAY output 30msec 'L' pulse
25	P46	PC2B	I/O	-	ON	-	L	H	PGM2 Fader CUE output 30msec 'L' pulse
26	P47	P47	O	-	ON	-	L	L	Not used
27	D8	D0	D/I	-	-	-	-	-	Data bus
28	D9	D1	D/I	-	-	-	-	-	Data bus
29	D10	D2	D/I	-	-	-	-	-	Data bus
30	D11	D3	D/I	-	-	-	-	-	Data bus
31	D12	D4	D/I	-	-	-	-	-	Data bus
32	D13	D5	D/I	-	-	-	-	-	Data bus

Pin No.	Pin Name	Symbol	I/O	Det	Int Pu	Ext	Res	Ini	Function
33	D14	D6	D/I	-	-	-	-	-	Data bus
34	D15	D7	D/I	-	-	-	-	-	Data bus
35	Vcc	Vcc	-	-	-	-	-	-	Power supply(+5V)
36	A0	A0	A/O	-	-	-	-	-	Address bus
37	A1	A1	A/O	-	-	-	-	-	Address bus
38	A2	A2	A/O	-	-	-	-	-	Address bus
39	A3	A3	A/O	-	-	-	-	-	Address bus
40	A4	A4	A/O	-	-	-	-	-	Address bus
41	A5	A5	A/O	-	-	-	-	-	Address bus
42	A6	A6	A/O	-	-	-	-	-	Address bus
43	A7	A7	A/O	-	-	-	-	-	Address bus
44	Vss	Vss	-	-	-	-	-	-	GND(0V)
45	A8	A8	A/O	-	-	-	-	-	Address bus
46	A9	A9	A/O	-	-	-	-	-	Address bus
47	A10	A10	A/O	-	-	-	-	-	Address bus
48	A11	A11	A/O	-	-	-	-	-	Address bus
49	A12	A12	A/O	-	-	-	-	-	Address bus
50	A13	A13	A/O	-	-	-	-	-	Address bus
51	A14	A14	A/O	-	-	-	-	-	Address bus
52	A15	A15	A/O	-	-	-	-	-	Address bus
53	A16	A16	A/O	-	-	-	-	-	Address bus
54	A17	A17	A/O	-	-	-	-	-	Address bus
55	P52	_FX1ON	O	-	ON	-	L	H	PGM1 EFFECT LOOP enabler 'L': enabler (DN-X300 only)
56	P53	_FX2ON	O	-	ON	-	L	H	PGM2 EFFECT LOOP enabler 'L': enabler (DN-X300 only)
57	Vss	Vss	-	-	-	-	-	-	GND(0V)
58	P60	LEDFX1	O	-	-	Pu	L	H	PGM1 EFFECT LOOP LED control. (DN-X300 only)
59	P61	LEDFX2	O	-	-	Pu	L	H	PGM2 EFFECT LOOP LED control. (DN-X300 only)
60	P62	FX1SW	I	-	-	-	L	H	PGM1 EFFECT LOOP ON/OFF SW 'L': ON (DN-X300 only)
61	P67	P67	I	-	-	-	H	H	DN-X100/300 program selected Pin 'L': DN-X300
62	_STBY	_STBY	-	-	-	-	-	H	When driven low,this pin forces a transition to hardware standby mode.
63	_RES	_RES	-	-	-	-	-	-	Reset signal 'L': Reset
64	NMI	NMI	I	-	-	Pu	-	H	Not used
65	Vss	Vss	-	-	-	-	-	-	GND(0V)
66	EXTAL	EXTAL	-	-	-	-	-	-	OSC 16MHz
67	XTAL	XTAL	-	-	-	-	-	-	OSC 16MHz
68	Vcc	Vcc	-	-	-	-	-	-	Power supply(+5V)
69	_AS	_AS	-	-	-	-	-	-	Not used
70	_RD	_RD	O	-	-	-	-	-	Goes low to indicate reading from the external address space
71	_HWR	_HWR	-	-	-	-	-	-	Not used
72	P66	JDET	I	-	-	-	L	H	Check Send Return jack inserted
73	MD0	MD0	I	-	-	-	-	-	IC Operating mode control
74	MD1	MD1	I	-	-	-	-	-	IC Operating mode control
75	MD2	MD2	I	-	-	-	-	-	IC Operating mode control
76	Avcc	Avcc	-	-	-	-	-	-	Power supply pin for the A/D converters(+5V).
77	Vref	Vref	-	-	-	-	-	-	Reference voltage input pin for the A/D converters(+5V).
78	P70,AN0	CH1FADER	I	-	-	-	-	Hi-z	CH1 FADER VR A/D converter
79	P71,AN1	CFFADER	I	-	-	-	-	Hi-z	CROSS FADER VR A/D converter
80	P72,AN2	CH2FADER	I	-	-	-	-	Hi-z	CH2 FADER VR A/D converter
81	P73,AN3	CH1CUREV	I	-	-	-	-	Hi-z	CH1 FADER CONTOUR VR A/D converter
82	P74,AN4	CFCUREV	I	-	-	-	-	Hi-z	CROSS FADER CONTOUR VR A/D converter
83	P75,AN5	CH2CUREV	I	-	-	-	-	Hi-z	CH2 FADER CONTOUR VR A/D converter
84	P76,AN6	AN6	I	-	-	-	-	Hi-z	Not used
85	P77,AN7	AN7	I	-	-	-	-	Hi-z	Not used
86	Avss	Avss	-	-	-	-	-	-	Ground pin for A/D converters(0V).
87	P80	P80	O	-	-	Pu	L	L	Not used

Pin No.	Pin Name	Symbol	I/O	Det	Int Pu	Ext	Res	Ini	Function
88	P81	P81	O	-	-	Pu	L	L	Not used
89	P82	P82	O	-	-	Pu	L	L	Not used
90	P83	CH1REV	O	-	-	Pu	L	H	CH1 FADER REVERSE SW 'L' : ON
91	P84,_CS	_CE	O	-	-	-	L	L	Chip select signal.
92	Vss	Vss	-	-	-	-	-	-	GND(0V)
93	PA0	CFREV	I	-	-	Pu	L	H	CROSSFADER REVERSE SW 'L' : ON
94	PA1	CH2REV	I	-	-	Pu	L	H	CH2 FADER REVERSE SW 'L' : ON
95	PA2	CH2FS	I	-	-	Pu	L	H	CH2 FADER START SW 'L' : ON
96	PA3	2CFS	I	-	-	Pu	L	H	CROSSFADER START B SW 'L' : ON
97	PA4	C1	O	-	-	-	L	H	PWM output control PGM1 volume
98	PA5	1CFS	I	-	-	Pu	L	H	CROSSFADER START A SW 'L' : ON
99	PA6	C2	O	-	-	-	L	H	PWM output control PGM2 volume
100	PA7	PA7	O	-	-	Pu	L	L	Not used

LB1482M (IC701)

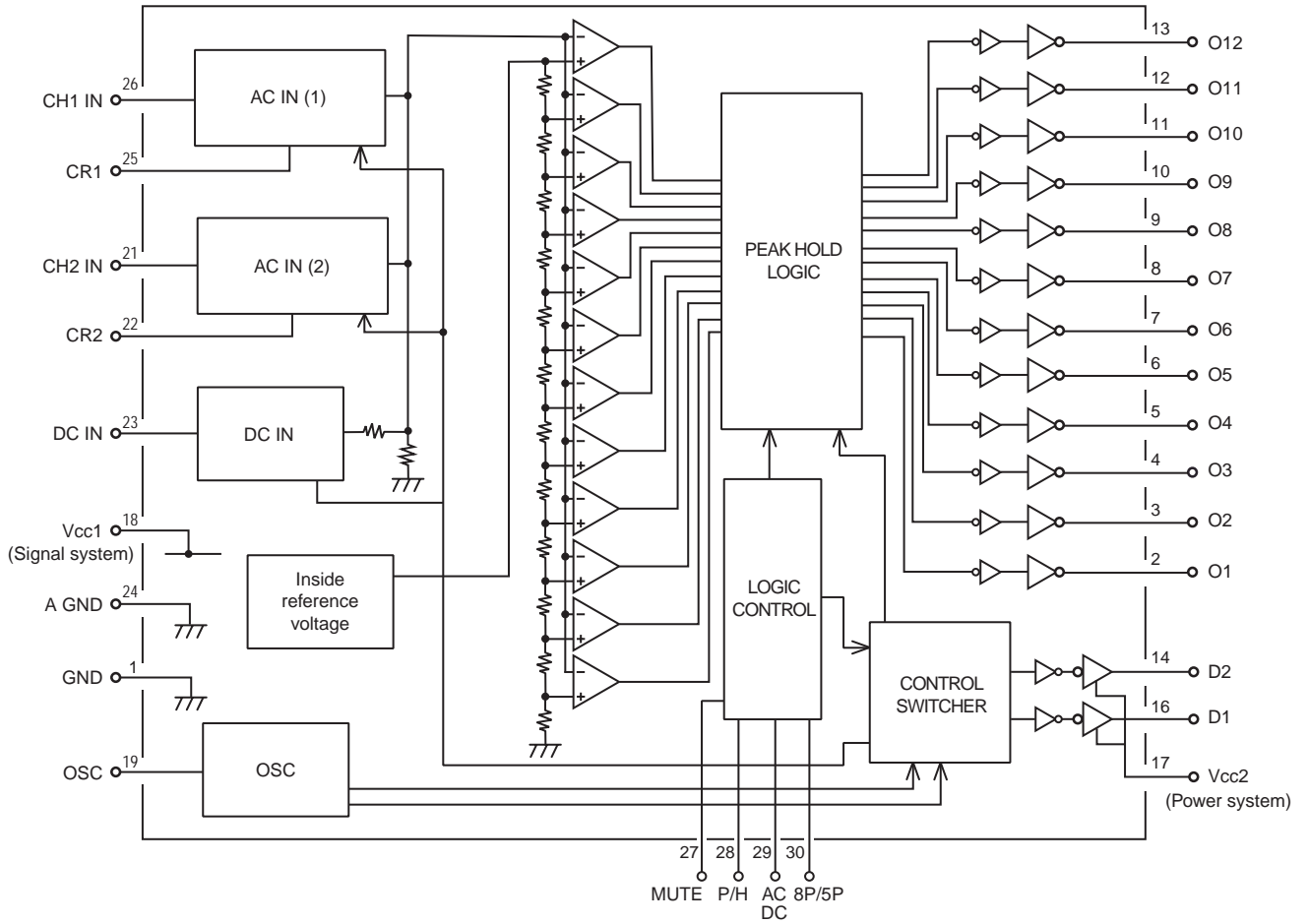
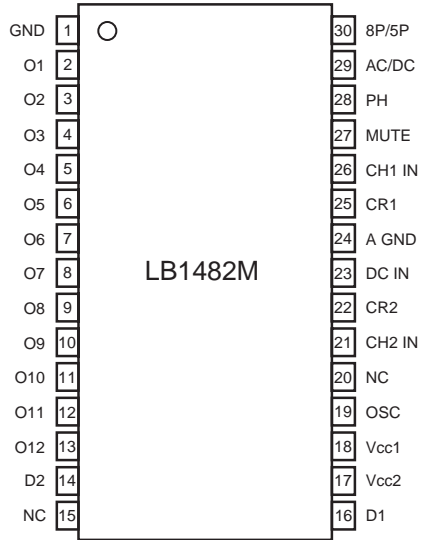

TC4053BF (IC507)

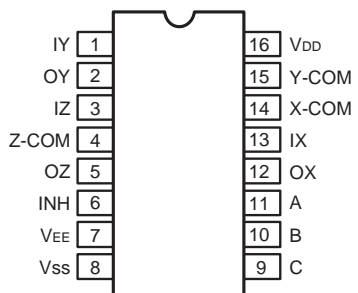

NJM2060 (IC105, 106, 205, 206, 952)

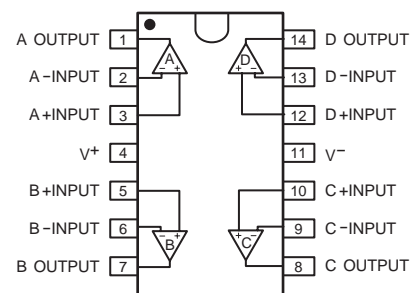

M51132L (IC109, 209)

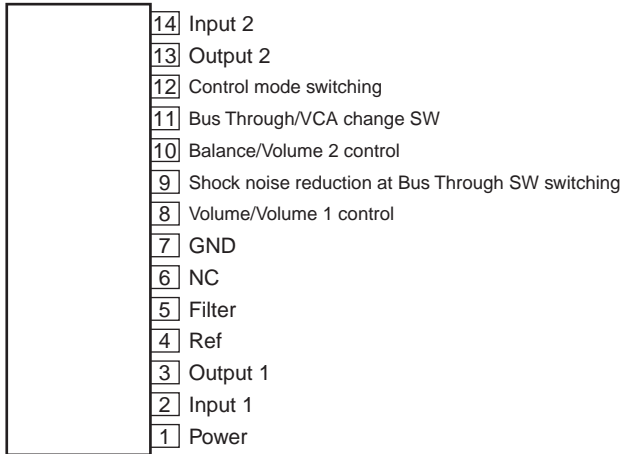

1M FLASH MEMORY (IC802)

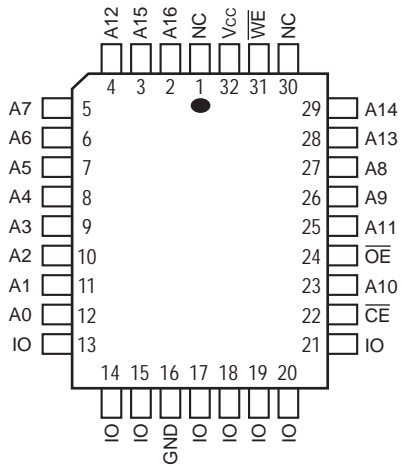

ADG212A (IC113, 213)

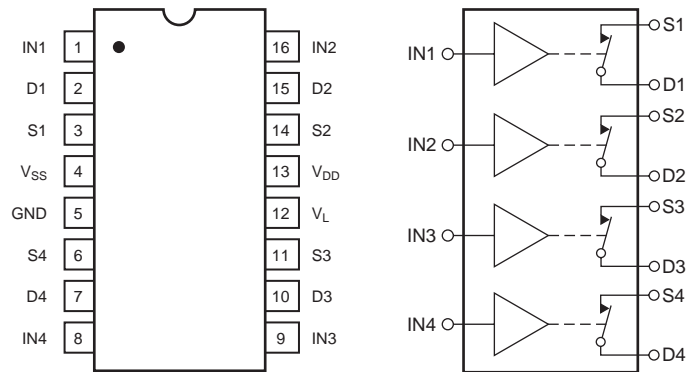

BD4745G (IC803)

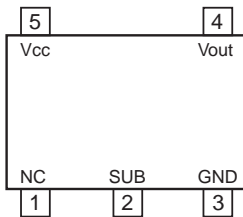

PRINTED WIRING BOARDS

MIXER P.W.B. UNIT

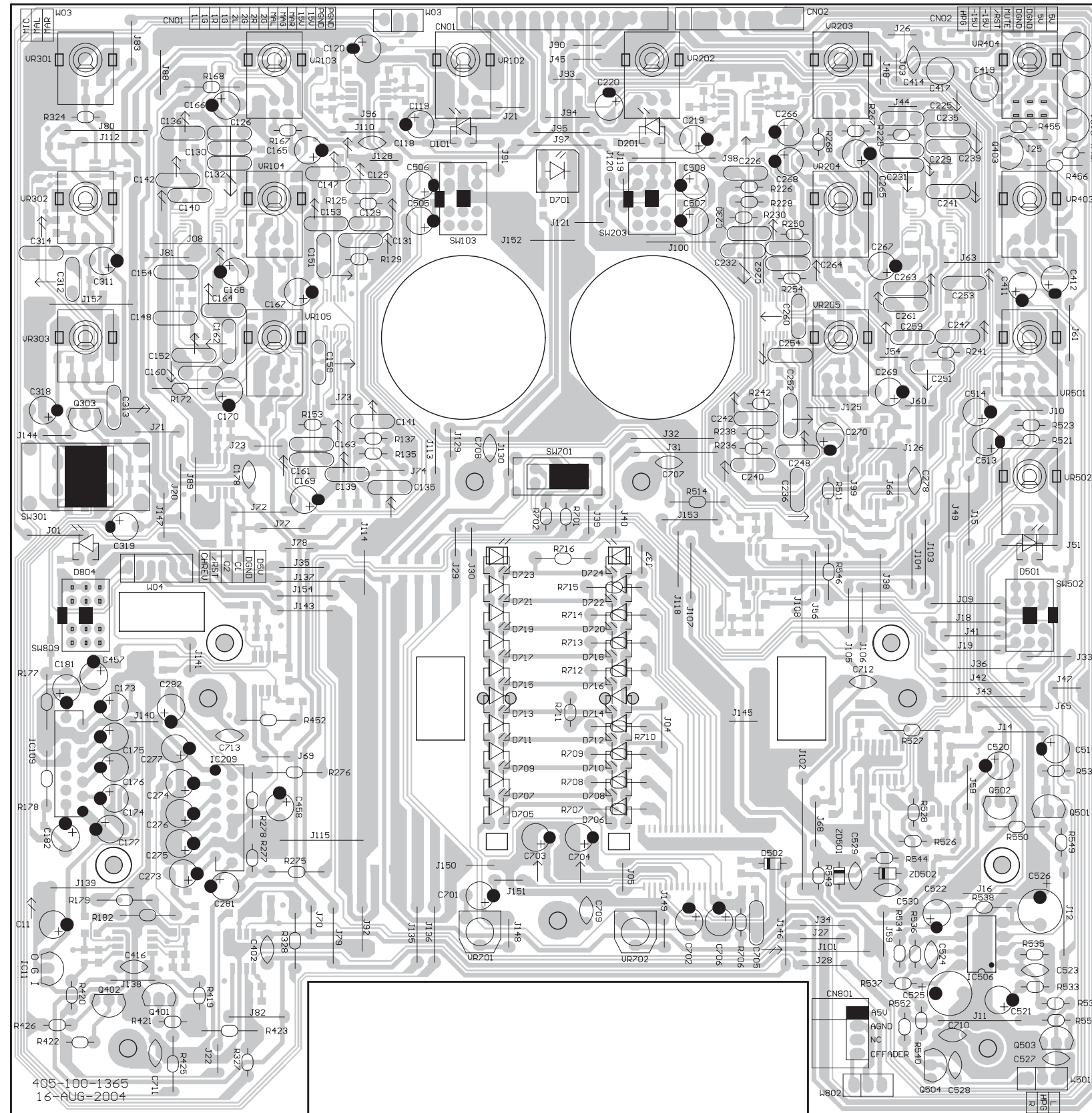

COMPONENT SIDE

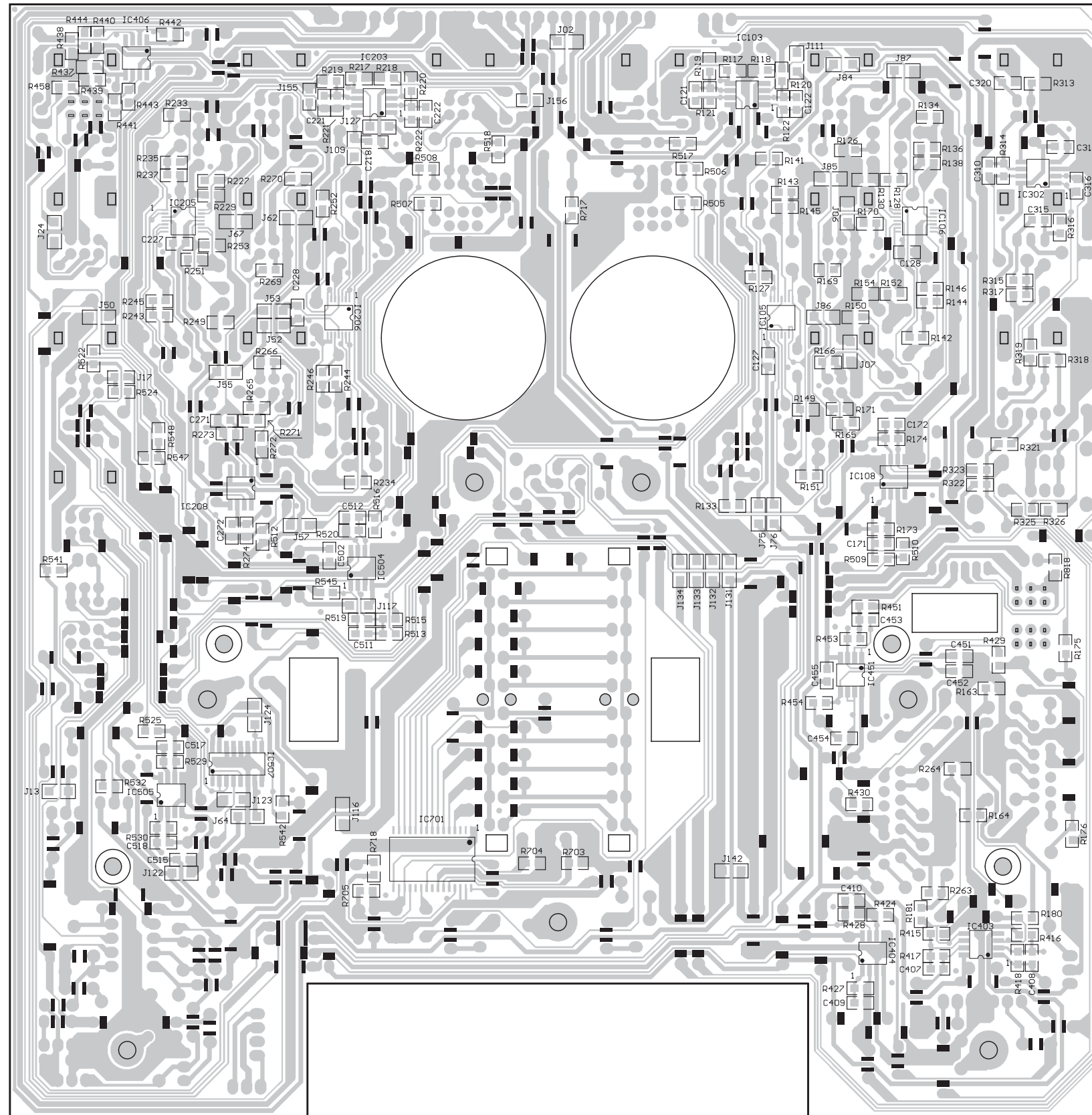

FOIL SIDE

JACK P.W.B. UNIT

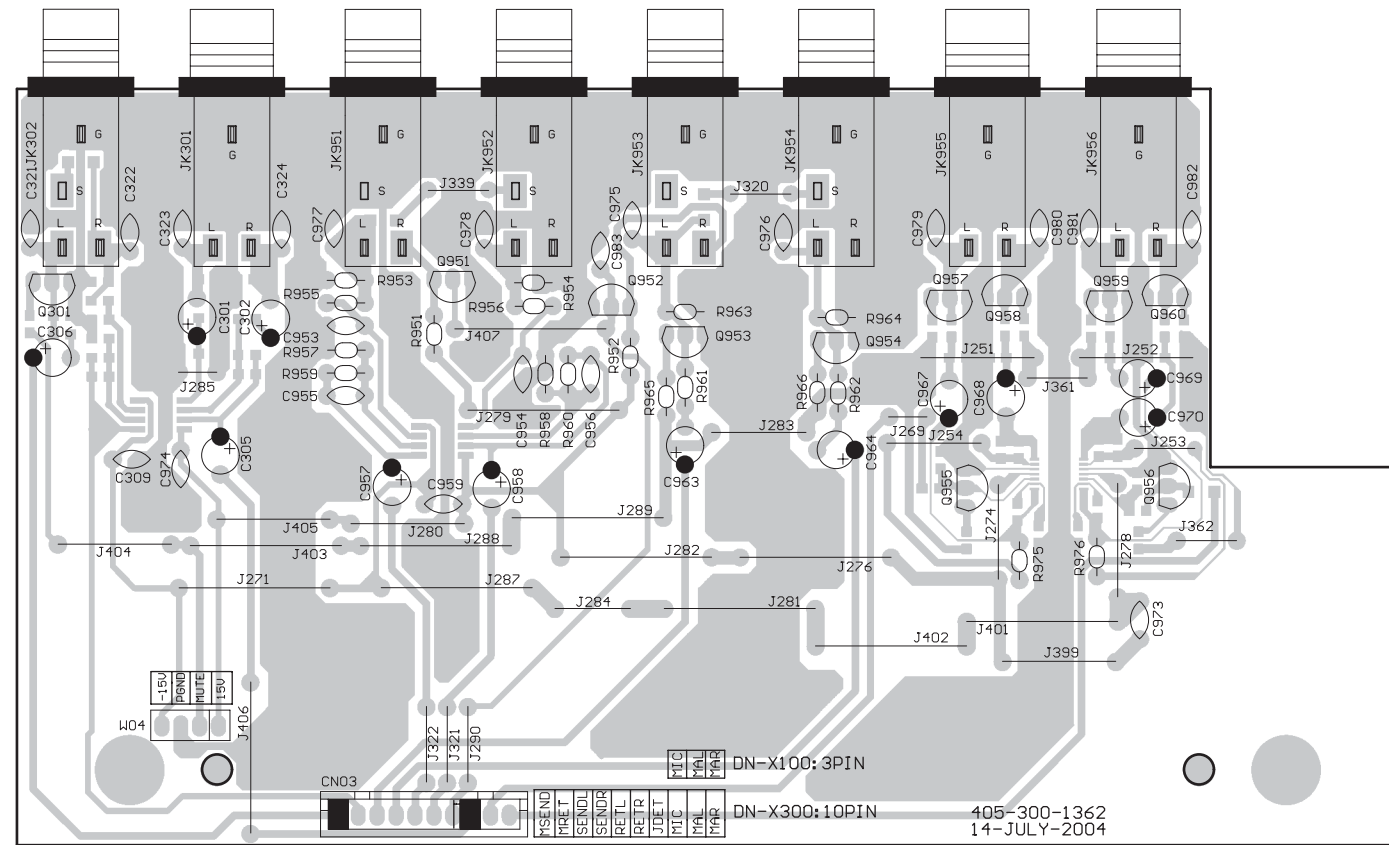

COMPONENT SIDE

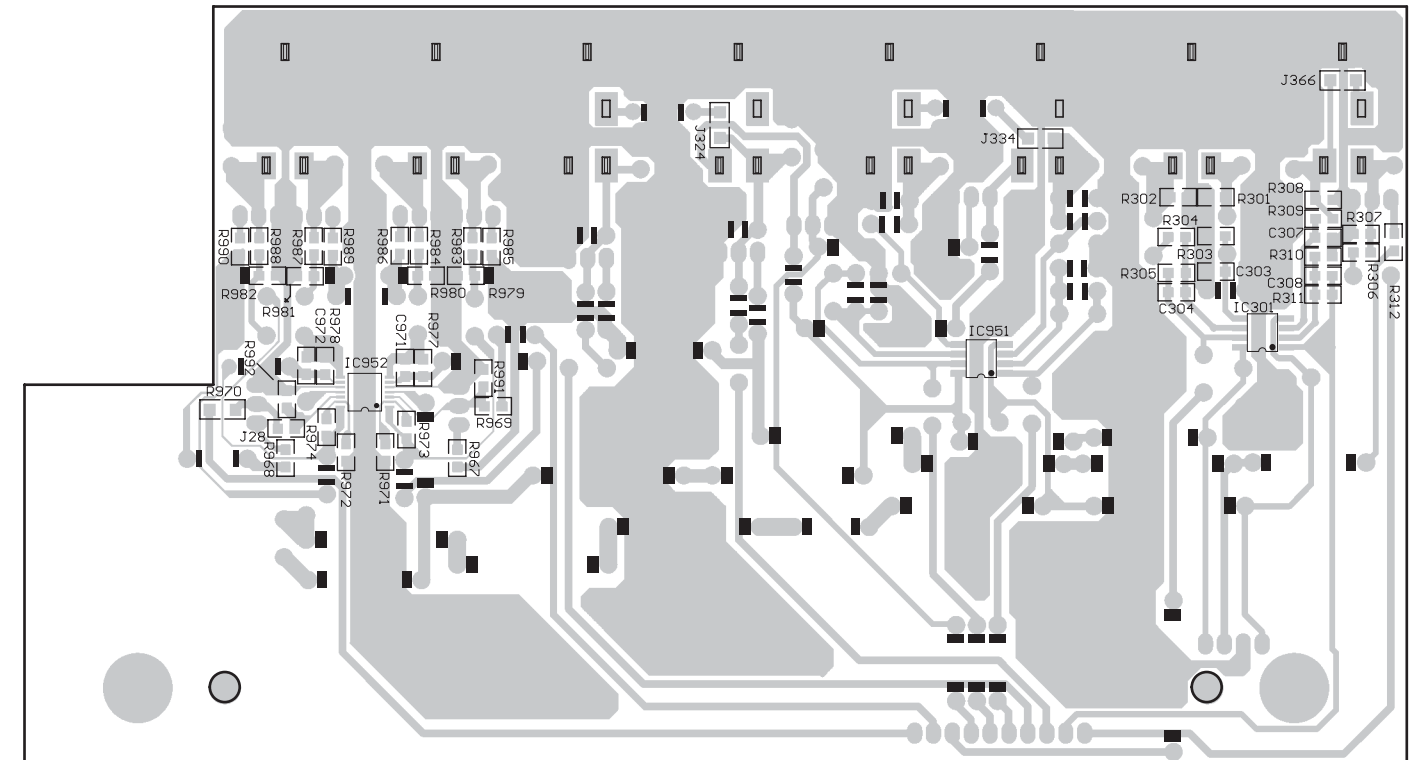

FOIL SIDE

CPU P.W.B. UNIT

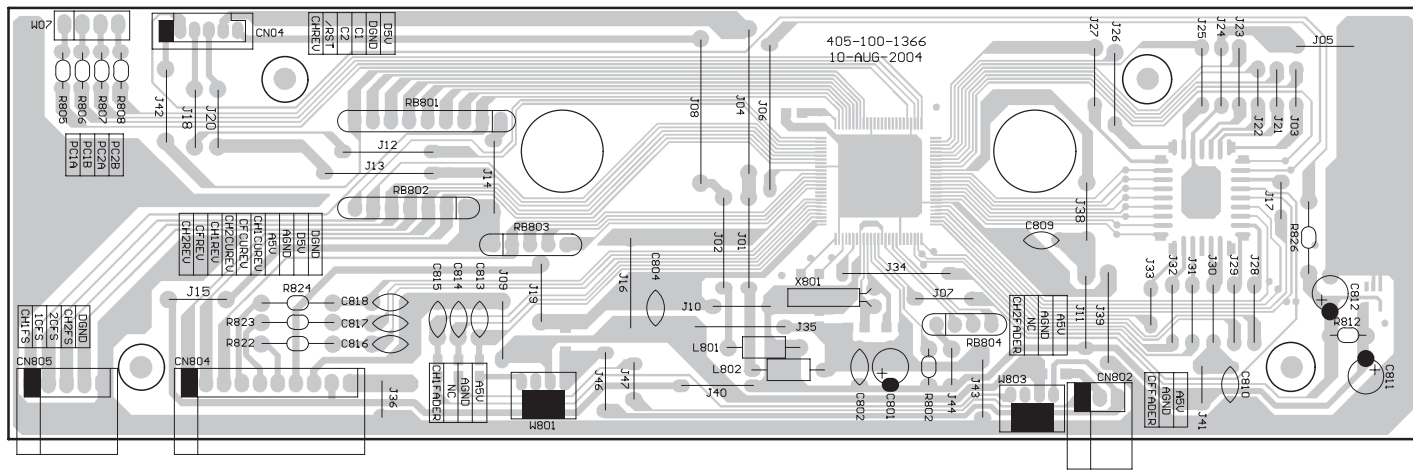

COMPONENT SIDE

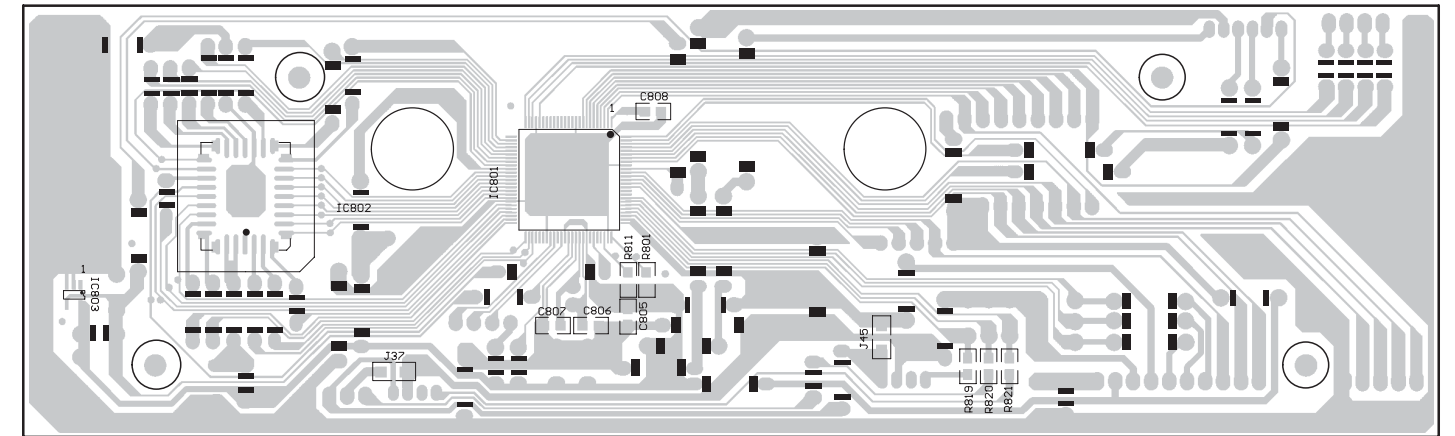

FOIL SIDE

REVERSE P.W.B. UNIT

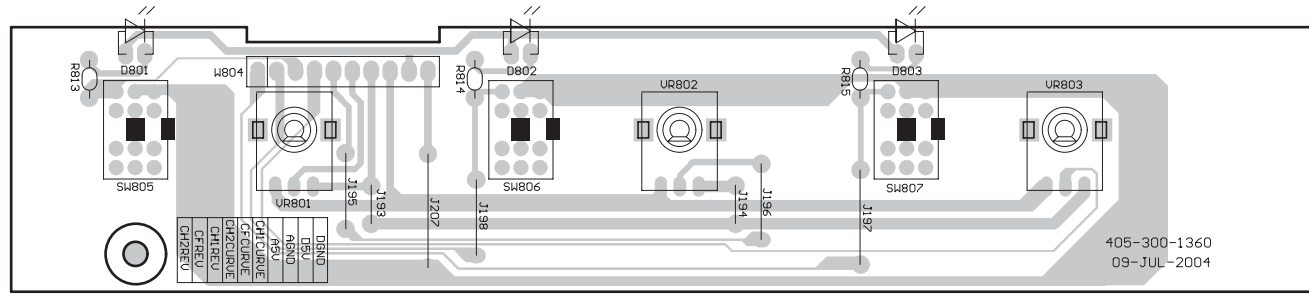

COMPONENT SIDE

PHONE P.W.B. UNIT

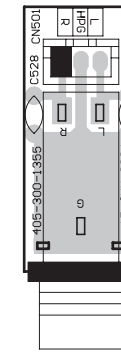

COMPONENT SIDE

FADER START P.W.B. UNIT

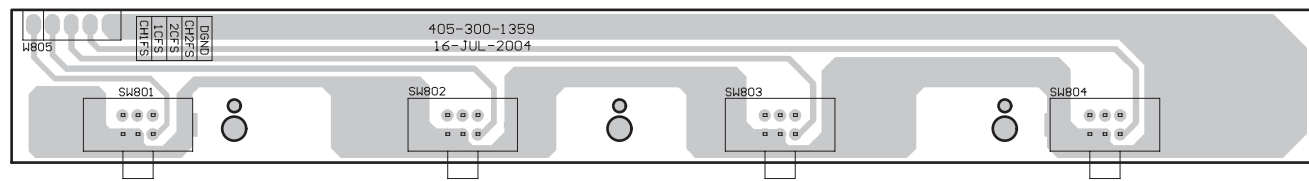

COMPONENT SIDE

CH VR P.W.B. UNIT

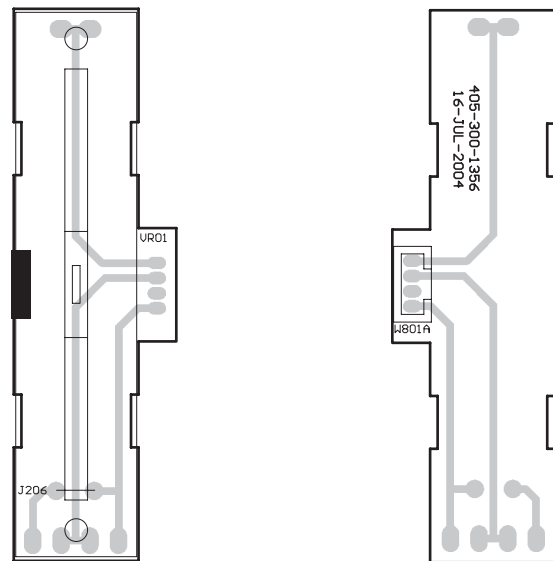

COMPONENT SIDE

FOIL SIDE

TRANS P.W.B. UNIT

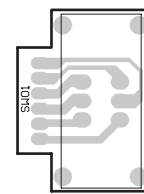

COMPONENT SIDE

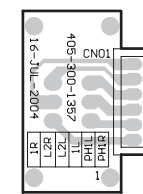

FOIL SIDE

NOTE FOR PARTS LIST

- Part indicated with the mark "◎" are not always in stock and possibly to take a long period of time for supplying, or in some case supplying of part may be refused.
- When ordering of part, clearly indicate "1" and "I" (i) to avoid mis-supplying.
- Ordering part without stating its part number can not be supplied.
- Part indicated with the mark "★" is not illustrated in the exploded view.
- Not including Carbon Film Resister ±5%, 1/4W Type in the P.W.Board parts list. (Refer to the Schematic Diagram for those parts.)
- Not including Carbon Chip Resister 1/16W Type in the P.W.Board parts list. (Refer to the Schematic Diagram for those parts.)

WARNING:

Parts marked with this symbol Δ have critical characteristics. Use ONLY replacement parts recommended by the manufacturer.

部品表について

- 印の部品は常時在庫していませんので供給に長時間を要することがあります。場合によっては、供給をお断りすることがあります。
- 部品を発注する際は特に数字の“1”と英字の“1”との区別をはっきり記入してください。
- 部品番号を表示していない部品は供給できません。
- Δ 印の部品は安全上重要な部品です。交換するときは、安全および性能維持のため必ず指定の部品をご使用ください。
- ★印のついている部品は分解図中には記載していません。
- カーボン抵抗器±5%、1/4W型は記載していません。定数は回路図を参照願います。
- カーボンチップ抵抗器1/16W型は記載していません。定数は回路図を参照願います。
- 部品表の抵抗器、コンデンサの品名記号の読み方は表を参照してください。

● Resistors

Ex.: **RN** **14K** **2E** **182** **G** **FR**
 Type Shape and performance Power Resistance Allowable error Others

RD : Carbon RC : Composition RS : Metal oxide film RW : Winding RN : Metal film RK : Metal mixture	2B : 1/8W 2E : 1/4W 2H : 1/2W 3A : 1W 3D : 2W 3F : 3W 3H : 5W	F : ±1% G : ±2% J : ±5% K : ±10% M : ±20%	P : Pulse-resistant type NL : Low noise type NB : Non-burning type FR : Fuse-resistor F : Lead wire forming
---	---	---	---

*** Resistance**

$1 \overset{8}{\text{---}} \overset{2}{\text{---}}$ ⇒ 1800 ohm = 1.8 kohm
 Indicates number of zeros after effective number. 2-digit effective number.

• Units: ohm

$1 \overset{R}{\text{---}} \overset{2}{\text{---}}$ ⇒ 1.2 ohm
 1-digit effective number. 2-digit effective number, decimal point indicated by R.

• Units: ohm

● 抵抗器

例) **RN** **14K** **2E** **182** **G** **FR**
 種類 形状特性 電力 抵抗値 許容差 その他

RD : カーボン RC : 固定体 RS : 金属系皮膜 RW : 巻線 RN : 金属皮膜 RK : 金属混合体	2B : 1/8 W 2E : 1/4 W 2H : 1/2 W 3A : 1 W 3D : 2 W 3F : 3 W 3H : 5 W	F : ±1% G : ±2% J : ±5% K : ±10% M : ±20%	P : 耐バルス形 NL : 低雑音形 NB : 不燃形 FR : ヒューズ抵抗 F : リード線成形
---	--	---	---

*** 抵抗値**

$18 \overset{2}{\text{---}}$ ⇒ 1800Ω=1.8kΩ
 有効数字につづく0の数を表わす。2桁の有効数字を表わす。

$1R \overset{2}{\text{---}}$ ⇒ 1.2Ω
 1桁の有効数字を表わす。2桁の有効数字で小数点はRで表わす。
 :単位はΩ

● Capacitors

Ex.: **CE** **04W** **1H** **2R2** **M** **BP**
 Type Shape and performance Dielectric strength Capacity Allowable error Others

CE : Aluminum foil electrolytic CA : Aluminum solid electrolytic CS : Tantalum electrolytic CQ : Film CK : Ceramic CC : Ceramic CP : Oil CM : Mica CF : Metallized CH : Metallized	0J : 6.3V 1A : 10V 1C : 16V 1E : 25V 1V : 35V 1H : 50V 2A : 100V 2B : 125V 2C : 160V 2D : 200V 2E : 250V 2H : 500V 2J : 630V	F : ±1% G : ±2% J : ±5% K : ±10% M : ±20% Z : +80% -20% P : +100% -0% C : ±0.25pF D : ±0.5pF = : Others	HS : High stability type BP : Non-polar type HR : Ripple-resistant type DL : For charge and discharge HF : For assuring high frequency U : UL part C : CSA part W : UL-CSA type F : Lead wire forming
---	--	--	---

*** Capacity (electrolyte only)**

$2 \overset{2}{\text{---}} \overset{2}{\text{---}}$ ⇒ 2200μF
 Indicates number of zeros after effective number. 2-digit effective number.

• Units: μF.

$2 \overset{R}{\text{---}} \overset{2}{\text{---}}$ ⇒ 2.2μF
 1-digit effective number. 2-digit effective number, decimal point indicated by R.

• Units: μF.

*** Capacity (except electrolyte)**

$2 \overset{2}{\text{---}} \overset{2}{\text{---}}$ ⇒ 2200pF=0.0022μF (More than 2) Indicates number of zeros after effective number. 2-digit effective number.

• Units: pF.

$2 \overset{2}{\text{---}} \overset{1}{\text{---}}$ ⇒ 220pF (0 or 1) Indicates number of zeros after effective number. 2-digit effective number.

• Units: pF.

• When the dielectric strength is indicated in AC, "AC" is included after the dielectric strength value.

● コンデンサ

例) **CE** **04W** **1H** **2R2** **M** **BP**
 種類 形状特性 耐圧 容量 許容差 その他

CE : アルミ箔電解 CA : アルミ固体電解 CS : タンタル電解 CQ : フィルム CK : セラミック CC : セラミック CP : オイル CM : マイカ CF : メタライズド CH : メタライズド	0J : 6.3 V 1A : 10 V 1C : 16 V 1E : 25 V 1V : 35 V 1H : 50 V 2A : 100 V 2B : 125 V 2C : 160 V 2D : 200 V 2E : 250 V 2H : 500 V 2J : 630 V	F : ±1% G : ±2% J : ±5% K : ±10% M : ±20% Z : +80% -20% P : +100% -0%	HS : 高安定形 BP : 無極性形 HR : 耐リップル形 DL : 充放電対策用 HF : 高周波保証用 U : UL 部品 C : CSA 部品 W : UL-CSA 部品 F : リード線成形
---	---	---	---

*** 容量値**

● 電解コンデンサの場合

$22 \overset{2}{\text{---}}$ ⇒ 2200μF $2R \overset{2}{\text{---}}$ ⇒ 2.2μF
 有効数字につづく0の数を表わす。2桁の有効数字を表わす。 1桁の有効数字を表わす。2桁の有効数字で小数点はRで表わす。
 :単位はμF :単位はμF

● 電解コンデンサ以外の場合

$22 \overset{2}{\text{---}}$ ⇒ 2200pF=0.0022μF $22 \overset{1}{\text{---}}$ ⇒ 220pF
 有効数字につづく0の数を表わす。(0の数が2以上の場合) 有効数字につづく0の数を表わす。(0の数が0または1の場合)
 2桁の有効数字を表わす。 2桁の有効数字を表わす。
 :単位はpF :単位はpF

● 耐圧を交流で表示する場合は、耐圧表示の次に「AC」を表示します。

PARTS LIST OF P.W.B. UNIT

*本表に記載されている部品は、補修用部品のため製品に使用している部品とは一部、形状、寸法などが異なる場合があります

Note: The symbols in the column "Remarks" indicate the following destinations.

E3: U.S.A. & Canada model E2: Europe model EK: U.K. model E2A: Asia model
E1C: China model EUT: Taiwan R.O.C. model E1K: Korea model JP: Japan model

MIXER P.W.B. UNIT ASS'Y

Ref. No.	Part No.	Part Name	Remarks	Q'ty	New
SEMICONDUCTORS GROUP					
IC11	00D 958 7035 308	IC(78L12)			
IC103	00D 958 7036 006	IC(BA15218F)			
IC105,106	00D 958 7035 900	IC(NJM-2060V)			
IC108	00D 958 7036 006	IC(BA15218F)			
IC109	00D 958 7036 103	IC(M51132L)			
IC203	00D 958 7036 006	IC(BA15218F)			
IC205,206	00D 958 7035 900	IC(NJM-2060V)			
IC208	00D 958 7036 006	IC(BA15218F)			
IC209	00D 958 7036 103	IC(M51132L)			
IC302	00D 958 7036 006	IC(BA15218F)			
IC403,404	00D 958 7036 006	IC(BA15218F)			
IC406	00D 958 7036 006	IC(BA15218F)			
IC451	00D 958 7036 006	IC(BA15218F)			
IC504,505	00D 958 7036 006	IC(BA15218F)			
IC506	00D 958 7035 104	INTEGRATED CIRCUIT(NJM-4556AD)			
IC507	00D 958 7034 804	IC(TC4053BFN)			
IC701	00D 958 7035 201	IC(LB1482M)			
Q303	00D 958 0040 701	TRANSISTOR(DTA124ES)			
Q401-404	00D 958 7034 707	TRANSISTOR(2SC2878-B)			
Q501-504	00D 958 7034 707	TRANSISTOR(2SC2878-B)			
D101	00D 958 7024 209	LED (LTL-16KA)			
D201	00D 958 7024 209	LED (LTL-16KA)			
D501	00D 958 0041 700	LED (RED)			
D502	00D 958 0042 806	SWITCHING DIODE(1SS132/1SS133)			
D701	00D 958 7024 306	LED (LTL42UB5N,BLUE)			
D705-716	00D 958 0041 807	LED (GREEN)			
D717-722	00D 958 0045 104	LED (YELLOW)			
D723,724	00D 958 0041 700	LED (RED)			
D804	00D 958 0041 700	LED (RED)			
ZD501,502	00D 958 0049 003	ZENER DIODE(MTZJ8.2-B)			
RESISTORS GROUP					
VR102	00D 958 7036 404	ROTARY VR(20KA*2,RD09L12D001D)			
VR103-105	00D 958 7036 307	ROTARY VR(20KB*2,RD09L124A01A)			
VR202	00D 958 7036 404	ROTARY VR(20KA*2,RD09L12D001D)			
VR203-205	00D 958 7036 307	ROTARY VR(20KB*2,RD09L124A01A)			
VR301	00D 958 7036 608	ROTARY VR(20KA,RD09L114003D)			
VR302,303	00D 958 7036 501	ROTARY VR(50KB,RD09L114A01B)			
VR403	00D 958 7036 307	ROTARY VR(20KMN,RD09L124A01B)			
VR404	00D 958 7036 404	ROTARY VR(20KA*2,RD09L12D001D)			
VR501	00D 958 7036 802	ROTARY VR(20KB*2,RD09L12DA00A)			
VR502	00D 958 7036 404	ROTARY VR(20KA*2,RD09L12D001D)			
VR701,702	00D 958 7019 502	SEMI FIXED RESISTOR(3.3K OHM)			

Ref. No.	Part No.	Part Name	Remarks	Q'ty	New
CAPACITORS GROUP					
C11	00D 958 7032 806	ELEC. CAPACITOR(100uF/16V,M)			
C118	00D 958 7029 107	CERAMIC CAPACITOR(0.1uF/50V,Z)			
C119,120	00D 958 7033 902	ELEC. CAPACITOR(1uF/50V,M)			
C121,122	00D 958 7030 808	CHIP CAPACITOR(100pF/50V,J)			
C125,126	00D 958 7032 204	POLYESTER CAPACITOR(0.0082uF/50V,J)			
C127,128	00D 958 7030 905	CHIP CAPACITOR(0.1uF/ 50V,Z)			
C129-132	00D 958 7032 000	POLYESTER CAPACITOR(0.0018uF/50V,J)			
C135,136	00D 958 7033 407	POLYESTER CAPACITOR(0.1uF/100V,J)			
C139,140	00D 958 7032 505	POLYESTER ACPACITOR(0.056uF/50V,J)			
C141,142	00D 958 7029 806	POLYESTER CAPACITOR(0.01uF/50V,J)			
C147,148	00D 958 7032 204	POLYESTER CAPACITOR(0.0082uF/50V,J)			
C151,152	00D 958 0021 209	POLYESTER CAPACITOR(0.0047uF/100V,J)			
C153,154	00D 958 7031 700	POLYESTER CAPACITOR(820pF/50V,J)			
C159,160	00D 958 7033 407	POLYESTER CAPACITOR(0.1uF/100V,J)			
C161-164	00D 958 7033 106	POLYESTER CAPACITOR(0.022uF/50V,J)			
C165-168	00D 958 7032 602	ELEC. CAPACITOR(4.7uF/50V,M)			
C169,170	00D 958 7034 008	ELEC. CAPACITOR(10uF/25V,M)			
C171,172	00D 958 7030 206	CHIP CAPACITOR(33pF/50V,J)			
C173,174	00D 958 7030 701	ELEC. CAPACITOR(2.2uF/50V,M)			
C175	00D 958 7032 602	ELEC. CAPACITOR(4.7uF/50V,M)			
C176	00D 958 7034 105	ELEC. CAPACITOR(22uF/16V,M)			
C177	00D 958 7034 008	ELEC. CAPACITOR(10uF/25V,M)			
C178	00D 958 7029 107	CERAMIC CAPACITOR(0.1uF/50V,Z)			
C181,182	00D 958 7034 008	ELEC. CAPACITOR(10uF/25V,M)			
C218	00D 958 7030 905	CHIP CAPACITOR(0.1uF/ 50V,Z)			
C219,220	00D 958 7033 902	ELEC. CAPACITOR(1uF/50V,M)			
C221,222	00D 958 7030 808	CHIP CAPACITOR(100pF/50V,J)			
C225,226	00D 958 7032 204	POLYESTER CAPACITOR(0.0082uF/50V,J)			
C227,228	00D 958 7030 905	CHIP CAPACITOR(0.1uF/ 50V,Z)			
C229-232	00D 958 7032 000	POLYESTER CAPACITOR(0.0018uF/50V,J)			
C235,236	00D 958 7033 407	POLYESTER CAPACITOR(0.1uF/100V,J)			
C239,240	00D 958 7032 505	POLYESTER ACPACITOR(0.056uF/50V,J)			
C241,242	00D 958 7029 806	POLYESTER CAPACITOR(0.01uF/50V,J)			
C247,248	00D 958 7032 204	POLYESTER CAPACITOR(0.0082uF/50V,J)			
C251,252	00D 958 0021 209	POLYESTER CAPACITOR(0.0047uF/100V,J)			
C253,254	00D 958 7031 700	POLYESTER CAPACITOR(820pF/50V,J)			
C259,260	00D 958 7033 407	POLYESTER CAPACITOR(0.1uF/100V,J)			
C261-264	00D 958 7033 106	POLYESTER CAPACITOR(0.022uF/50V,J)			
C265-268	00D 958 7032 602	ELEC. CAPACITOR(4.7uF/50V,M)			
C269,270	00D 958 7034 008	ELEC. CAPACITOR(10uF/25V,M)			
C271,272	00D 958 7030 206	CHIP CAPACITOR(33pF/50V,J)			
C273,274	00D 958 7030 701	ELEC. CAPACITOR(2.2uF/50V,M)			
C275	00D 958 7032 602	ELEC. CAPACITOR(4.7uF/50V,M)			
C276	00D 958 7034 105	ELEC. CAPACITOR(22uF/16V,M)			
C277	00D 958 7034 008	ELEC. CAPACITOR(10uF/25V,M)			
C278	00D 958 7029 107	CERAMIC CAPACITOR(0.1uF/50V,Z)			
C281,282	00D 958 7034 008	ELEC. CAPACITOR(10uF/25V,M)			
C310	00D 958 7033 708	CHIP CAPACITOR(68pF/50V,J)			
C311	00D 958 7034 008	ELEC. CAPACITOR(10uF/25V,M)			
C312,313	00D 958 7033 106	POLYESTER CAPACITOR(0.022uF/50V,J)			
C314	00D 958 7033 203	POLYESTER CAPACITOR(0.0033uF/100V,J)			
C315	00D 958 7031 506	CHIP CAPACITOR(270pF/50V,J)			
C316	00D 958 7030 303	CHIP CAPACITOR(22pF/50V,J)			
C317	00D 958 7030 905	CHIP CAPACITOR(0.1uF/ 50V,Z)			
C318	00D 958 7034 008	ELEC. CAPACITOR(10uF/25V,M)			

Ref. No.	Part No.	Part Name	Remarks	Q'ty	New
C319	00D 958 7030 507	ELEC. CAPACITOR(10uF/50V,M)			
C320	00D 958 7030 109	CHIP CAPACITOR(220pF/50V,J)			
C402	00D 958 7029 107	CERAMIC CAPACITOR(0.1uF/50V,Z)			
C407,408	00D 958 7030 303	CHIP CAPACITOR(22pF/50V,J)			
C409,410	00D 958 7030 002	CHIP CAPACITOR(47pF/50V,J)			
C411,412	00D 958 7034 008	ELEC. CAPACITOR(10uF/25V,M)			
C414	00D 958 7030 905	CHIP CAPACITOR(0.1uF/ 50V,Z)			
C416	00D 958 7029 107	CERAMIC CAPACITOR(0.1uF/50V,Z)			
C451,452	00D 958 7031 205	CHIP CAPACITOR(0.22uF/50V,Z)			
C453,454	00D 958 7033 805	POLYESTER CAPACITOR(0.47uF/50V,J)			
C455	00D 958 7030 905	CHIP CAPACITOR(0.1uF/ 50V,Z)			
C502	00D 958 7030 905	CHIP CAPACITOR(0.1uF/ 50V,Z)			
C505-508	00D 958 7032 602	ELEC. CAPACITOR(4.7uF/50V,M)			
C511,512	00D 958 7031 001	CHIP CAPACITOR(15pF/ 50V,J)			
C513,514	00D 958 7032 602	ELEC. CAPACITOR(4.7uF/50V,M)			
C515	00D 958 7030 905	CHIP CAPACITOR(0.1uF/ 50V,Z)			
C517,518	00D 958 7030 206	CHIP CAPACITOR(33pF/50V,J)			
C519,520	00D 958 7034 008	ELEC. CAPACITOR(10uF/25V,M)			
C521,522	00D 958 7032 602	ELEC. CAPACITOR(4.7uF/50V,M)			
C523,524	00D 958 7028 904	CERAMIC CAPACITOR(68pF/50V,K)			
C525,526	00D 958 7032 806	ELEC. CAPACITOR(100uF/16V,M)			
C527,528	00D 958 7029 301	CERAMIC CAPACITOR(1500pF/50V,K)			
C529,530	00D 958 7029 107	CERAMIC CAPACITOR(0.1uF/50V,Z)			
C701,702	00D 958 7030 701	ELEC. CAPACITOR(2.2uF/50V,M)			
C703,704	00D 958 7034 008	ELEC. CAPACITOR(10uF/25V,M)			
C705	00D 958 7033 009	POLYESTER CAPACITOR(0.015uF/100V,J)			
C706	00D 958 7032 709	ELEC. CAPACITOR(220uF/10V,M)			
OTHER PARTS GROUP					
CN01	00D 958 7016 301	15P CONNECTOR WIRE			
CN02	00D 958 7023 404	9P CONNECTOR WIRE			
CN03	00D 958 7023 307	3P CONNECTOR WIRE			
SW103	00D 958 7014 701	PUSH SW(PSA-42E06L-O-250)			
SW203	00D 958 7014 701	PUSH SW(PSA-42E06L-O-250)			
SW301	00D 958 7015 205	LEVER SW(LBC23M-20K,8PIN)			
SW502	00D 958 7014 701	PUSH SW(PSA-42E06L-O-250)			
SW701	00D 958 7014 905	SW(SSH-22H03-G11-NS)			
SW809	00D 958 7014 701	PUSH SW(PSA-42E06L-O-250)			
W04	00D 958 7023 608	6P CONNECTOR WIRE			
W501	00D 958 7016 602	3P CONNECTOR WIRE			
	00D 958 7013 304	LED BASE			
	00D 958 7038 208	LED HOLDERT(LED3-12)	for D101		
	00D 958 7038 208	LED HOLDERT(LED3-12)	for D201		
	00D 958 7038 208	LED HOLDERT(LED3-12)	for D501		
	00D 958 7038 208	LED HOLDERT(LED3-12)	for D804		

OUTPUT P.W.B. UNIT ASS'Y

Ref. No.	Part No.	Part Name	Remarks	Q'ty	New
SEMICONDUCTORS GROUP					
IC01	00D 958 7035 502	IC(NJM7815FA)			
IC02	00D 941 0021 405	IC(NJM7915FA)			
IC03	00D 958 0040 303	IC 7805			
IC101	00D 958 7036 200	IC(NJM-4580M)			
IC102	00D 958 7036 006	IC(BA15218F)			
IC201	00D 958 7036 200	IC(NJM-4580M)			
IC202	00D 958 7036 006	IC(BA15218F)			
Q01	00D 958 0040 604	TRANSISTORS(2SC3330U)			
Q02	00D 958 0040 808	TRANSISTOR(DTA124TS)			
Q903,904	00D 958 7034 707	TRANSISTOR(2SC2878-B)			
D01-08	00D 958 7034 503	DIODE(1N4002/1N4002TA)			
D09-11	00D 958 0042 806	SWITCHING DIODE(1SS132/1SS133)			
D851-858	00D 958 7034 503	DIODE(1N4002/1N4002TA)			
ZD01	00D 958 0016 405	ZENER DIODE(MTZJ5.6-C)			
ZD02	00D 958 7034 600	ZENER DIODE(MTZJ10-B)			
CAPACITORS GROUP					
C05,06	00D 958 0044 105	ELEC. CAPACITOR(1000uF/25V,M)			
C07,08	00D 958 0044 202	ELEC. CAPACITOR(1000uF/35V,M)			
C09,10	00D 958 7029 107	CERAMIC CAPACITOR(0.1uF/50V,Z)			
C11,12	00D 958 7033 601	ELEC.CAPACITOR(100uF/16V,M)			
C13	00D 958 0044 105	ELEC. CAPACITOR(1000uF/25V,M)			
C14	00D 958 7030 905	CHIP CAPACITOR(0.1uF/ 50V,Z)			
C15	00D 958 7029 505	ELEC. CAPACITOR(100uF/10V,M)			
C16	00D 958 7030 604	ELEC. CAPACITOR(220uF/25V,M)			
C17	00D 958 7032 408	ELEC. CAPACITOR(22uF/16V,M)			
C101,102	00D 958 7031 603	CHIP CAPACITOR(390pF/50V,J)			
C103,104	00D 958 7032 408	ELEC. CAPACITOR(22uF/16V,M)			
C105,106	00D 958 7030 808	CHIP CAPACITOR(100pF/50V,J)			
C107,108	00D 958 7033 601	ELEC.CAPACITOR(100uF/16V,M)			
C109,110	00D 958 7032 301	POLYESTER CAPACITOR(0.027uF/50V,J)			
C111,112	00D 958 7032 204	POLYESTER CAPACITOR(0.0082uF/50V,J)			
C113,114	00D 958 7033 601	ELEC.CAPACITOR(100uF/16V,M)			
C115,116	00D 958 7032 408	ELEC. CAPACITOR(22uF/16V,M)			
C117	00D 958 7029 107	CERAMIC CAPACITOR(0.1uF/50V,Z)			
C201,202	00D 958 7031 603	CHIP CAPACITOR(390pF/50V,J)			
C203,204	00D 958 7032 408	ELEC. CAPACITOR(22uF/16V,M)			
C205,206	00D 958 7030 808	CHIP CAPACITOR(100pF/50V,J)			
C207,208	00D 958 7033 601	ELEC.CAPACITOR(100uF/16V,M)			
C209,210	00D 958 7032 301	POLYESTER CAPACITOR(0.027uF/50V,J)			
C211,212	00D 958 7032 204	POLYESTER CAPACITOR(0.0082uF/50V,J)			
C213,214	00D 958 7033 601	ELEC.CAPACITOR(100uF/16V,M)			
C215,216	00D 958 7032 408	ELEC. CAPACITOR(22uF/16V,M)			
C217	00D 958 7029 107	CERAMIC CAPACITOR(0.1uF/50V,Z)			
C851-854	00D 958 7030 905	CHIP CAPACITOR(0.1uF/ 50V,Z)			
C855-860	00D 958 7033 504	CHIP CAPACITOR(470pF/50V,K)			
C911,912	00D 958 7029 709	ELEC. CAPACTIOR(10uF/25V,M)			
C915,916	00D 958 7033 504	CHIP CAPACITOR(470pF/50V,K)			

Ref. No.	Part No.	Part Name	Remarks	Q'ty	New
OTHER PARTS GROUP					
CN03	00D 958 7017 504	4P SOCKET			
CN04	00D 958 7017 708	4P SOCKET			
CN05	00D 958 7017 504	4P SOCKET			
CN06	00D 958 7037 801	RJ45 JACK			
CN07	00D 958 7023 705	15P SOCKET			
CN08	00D 958 7023 909	9P SOCKET			
JK101	00D 958 7037 704	4P RCA JACK			
JK201	00D 958 7037 704	4P RCA JACK			
JK851,852	00D 958 7037 306	HEADPHONE JACK(3.5)			
JK901	00D 958 7037 102	2P RCA JACK			
L01-03	00D 958 0016 900	BEAD CORE(86-019-A)			
SW101	00D 958 7015 409	SLIDE SW(SSSF122NA1-HF,6PIN)			
SW201	00D 958 7015 409	SLIDE SW(SSSF122NA1-HF,6PIN)			
W101	00D 958 7017 106	6P SOCKET			
W201	00D 958 7017 106	6P SOCKET			
	00D 958 7014 303	FIXED RACK(0.5t)			
	00D 958 7039 605	CUSHION(PORON,10*8*5t)			

JACK P.W.B. UNIT ASS'Y

Ref. No.	Part No.	Part Name	Remarks	Q'ty	New
SEMICONDUCTORS GROUP					
IC301	00D 958 7035 803	IC(NJM-2068M)			
IC952	00D 958 7035 900	IC(NJM-2060V)			
Q956-959	00D 958 7034 707	TRANSISTOR(2SC2878-B)			
CAPACITORS GROUP					
C301,302	00D 958 7032 408	ELEC. CAPACITOR(22uF/16V,M)			
C303	00D 958 7030 808	CHIP CAPACITOR(100pF/50V,J)			
C304	00D 958 7030 303	CHIP CAPACITOR(22pF/50V,J)			
C305	00D 958 7029 602	ELEC. CAPACITOR(4.7uF/50V,M)			
C307	00D 958 7031 603	CHIP CAPACITOR(390pF/50V,J)			
C309	00D 958 7029 107	CERAMIC CAPACITOR(0.1uF/50V,Z)			
C967-970	00D 958 7033 300	ELEC. CAPACITOR(47uF/16V,M)			
C971,972	00D 958 7030 206	CHIP CAPACITOR(33pF/50V,J)			
C973,974	00D 958 7029 107	CERAMIC CAPACITOR(0.1uF/50V,Z)			
OTHER PARTS GROUP					
CN03	00D 958 0021 801	3P SOCKET			
JK301	00D 958 7037 209	HEADPHONE JACK(6.4)			
JK955,956	00D 958 7037 209	HEADPHONE JACK(6.4)			

CPU P.W.B. UNIT ASS'Y

	Ref. No.	Part No.	Part Name	Remarks	Q'ty	New
SEMICONDUCTORS GROUP						
	IC801	00D 958 7035 405	IC(MAX003)	IC(W39F010P-70B)		
	IC802	00D 958 7014 400	CPU IC ASS'Y			
	IC803	00D 958 7035 609	IC(BD4745G)			
RESISTORS GROUP						
	RB801	00D 958 7022 405	FILM RESISTOR NETWORKS(10K OHM,J,8R9P)			
	RB802	00D 958 0014 601	FILM RESISTOR NETWORKS(10K OHM,J,6R7P)			
	RB803	00D 958 7026 702	FILM RESISTOR NETWORKS(10K OHM,J,4R5P)			
	RB804	00D 958 7022 007	FILM RESISTOR NETWORKS(10K OHM,J,3R4P)			
CAPACITORS GROUP						
	C801	00D 958 7029 505	ELEC. CAPACITOR(100uF/10V,M)			
	C802	00D 958 7029 107	CERAMIC CAPACITOR(0.1uF/50V,Z)			
	C804	00D 958 7029 107	CERAMIC CAPACITOR(0.1uF/50V,Z)			
	C805	00D 958 7030 905	CHIP CAPACITOR(0.1uF/ 50V,Z)			
	C806,807	00D 958 7031 108	CHIP CAPACITOR(20pF/ 50V,J)			
	C808	00D 958 7030 905	CHIP CAPACITOR(0.1uF/ 50V,Z)			
	C809,810	00D 958 7029 107	CERAMIC CAPACITOR(0.1uF/50V,Z)			
	C811	00D 958 7029 505	ELEC. CAPACITOR(100uF/10V,M)			
	C812	00D 958 7029 408	ELEC. CAPACITOR(2.2uF/50V,M)			
	C813-818	00D 958 7029 000	CERAMIC CAPACITOR(0.047uF/50V,Z)			
OTHER PARTS GROUP						
	CN04	00D 958 7017 106	6P SOCKET			
	CN804	00D 958 7017 203	10P SOCKET			
	CN805	00D 958 7023 802	6P SOCKET			
	L801,802	00D 958 0016 900	BEAD CORE(86-019-A)			
	W03	00D 958 7023 006	4P CONNECTOR WIRE			
	W801	00D 958 7016 000	4P CONNECTOR WIRE			
	W802	00D 958 7023 103	4P CONNECTOR WIRE			
	W803	00D 958 7016 000	4P CONNECTOR WIRE			
	X801	00D 958 7037 908	CITIZEN BRAND(CSA-309,16MHz)			
		00D 958 7015 603	SOCKET(PLCC32TS)			

CROSSFADER P.W.B. UNIT ASS'Y

Ref. No.	Part No.	Part Name	Remarks	Q'ty	New
RESISTORS GROUP					
VR01	00D 958 7037 005	SLIDE VR(RA45D2-211-15D1-R0B50K)			
OTHER PARTS GROUP					
W801A	00D 958 7017 601	4P SOCKE			
	00D 958 7022 900	FIXED PLATE FOR SLIDE VR			
	00D 958 7039 207	SCREW(ISOF,3*4,ZS)			

TRANS P.W.B. UNIT ASS'Y

Ref. No.	Part No.	Part Name	Remarks	Q'ty	New
OTHER PARTS GROUP					
CN01	00D 958 7017 106	6P SOCKET			
SW01	00D 958 7015 001	LEVEL SW(LB(C)-22B-095)			

CH VR P.W.B. UNIT ASS'Y

Ref. No.	Part No.	Part Name	Remarks	Q'ty	New
RESISTORS GROUP					
VR01	00D 958 7037 005	SLIDE VR(RA45D2-211-15D1-R0B50K)			
OTHER PARTS GROUP					
W801A	00D 958 7017 601	4P SOCKE			
	00D 958 7014 604	FIXING PLATE			
	00D 958 7039 207	SCREW(ISOF,3*4,ZS)			

FADER START P.W.B. UNIT ASS'Y

Ref. No.	Part No.	Part Name	Remarks	Q'ty	New
OTHER PARTS GROUP					
SW801-804	00D 958 7015 409	SLIDE SW(SSSF122NA1-HF,6PIN)			
W805	00D 958 7023 501	5P CONNECTOR WIRE			

REVERSE P.W.B. UNIT ASS'Y

Ref. No.	Part No.	Part Name	Remarks	Q'ty	New
SEMICONDUCTORS GROUP					
D801-803	00D 958 0041 700	LED (RED)			
RESISTORS GROUP					
VR801-803	00D 958 7036 307	ROTARY VR(10KB,RD09L114001K)			
OTHER PARTS GROUP					
SW805-807	00D 958 7014 701	PUSH SW(PSA-42E06L-O-250)			
W804	00D 958 7023 200	10P CONNECTOR WIRE			
	00D 958 7038 402	LED HOLDER	for D801-803		
	00D 958 0045 803	BRACKET(L TYPE)			
	00D 958 7038 907	SCREW(M3*P0.5*5L)			

PHONE P.W.B. UNIT ASS'Y

Ref. No.	Part No.	Part Name	Remarks	Q'ty	New
OTHER PARTS GROUP					
CN501	00D 958 0021 801	3P SOCKET			
JK501	00D 958 7037 209	HEADPHONE JACK(6.4)			

EXPLODED VIEW

Parts List

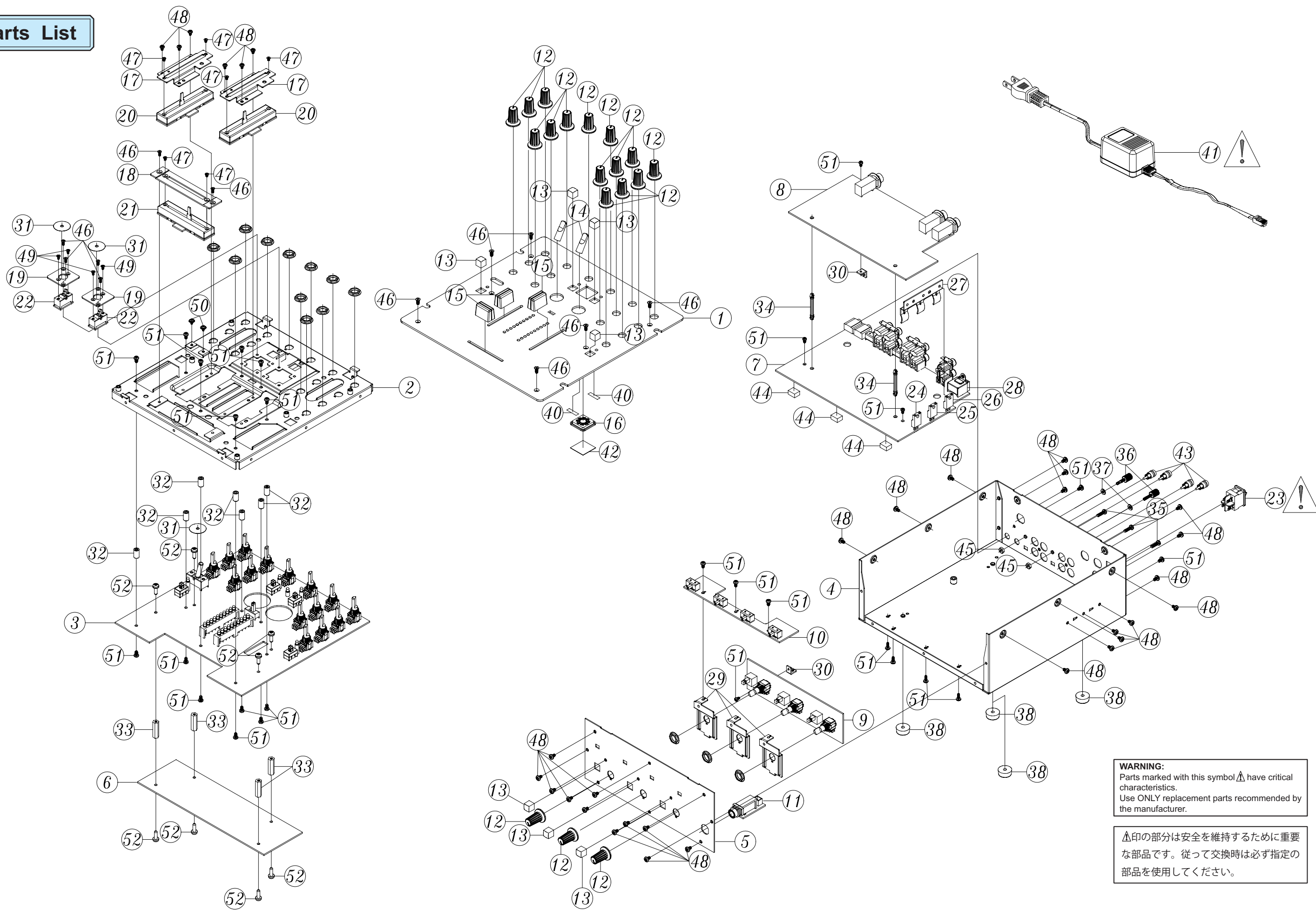

WARNING:
 Parts marked with this symbol  have critical characteristics.
 Use ONLY replacement parts recommended by the manufacturer.

印の部分は安全を維持するために重要な部品です。従って交換時は必ず指定の部品を使用してください。

PARTS LIST OF EXPLODED VIEW

*本表に記載されている部品は、補修用部品のため製品に使用している部品とは一部、形状、寸法などが異なる場合があります。

Note: The symbols in the column "Remarks" indicate the following destinations.

E3: U.S.A. & Canada model

E2: Europe model

EK: U.K. model

E2A: Asia model

E1C: China model

EUT: Taiwan R.O.C. model

E1K: Korea model

JP: Japan model

Ref. No.	Part No.	Part Name	Remarks	Q'ty	New
1	00D 958 7022 803	FRONT PANEL		1	
2	00D 958 7039 906	FRONT BOARD ASS'Y		1	*
3	00D 958 7040 306	MIXER PCB ASS'Y		1	*
4	00D 958 7040 005	BOTTOM BASE ASS'Y		1	*
5	00D 958 7013 906	FRONT COVER		1	
6	00D 958 7040 403	CPU PCB ASS'Y		1	*
7	00D 958 7040 500	OUTPUT PCB ASS'Y		1	*
8	00D 958 7040 607	JACK PCB ASS'Y		1	*
9	00D 958 7041 004	REVERSE PCB ASS'Y		1	*
10	00D 958 7040 908	FADER START PCB ASS'Y		1	*
11	00D 958 7043 206	PHONE PCB ASS'Y		1	*
12	00D 958 7012 907	ROTARY KNOB(ABS,BLACK)		18	*
13	00D 958 7013 100	SQUARE KNOB		7	*
14	00D 958 7013 508	POKE KNOB(BLACK)		2	*
15	00D 958 7013 401	PUSH KNOB		3	*
16	00D 958 7013 207	MARK WINDOW		1	*
17	00D 958 7014 604	FIXING PLATE		2	
18	00D 958 7022 900	FIXED PLATE FOR SLIDE VR		1	
19	00D 958 7014 507	APART BOARD		2	
20	00D 958 7043 109	CH VR PCB ASS'Y		2	
21	00D 958 7040 801	CROSSFADER PCB ASS'Y		1	*
22	00D 958 7043 002	TRANS PCB ASS'Y		2	*
23	00D 958 7040 704	POWER SW ASS'Y		1	*
24	00D 958 0040 303	IC 7805		1	
25	00D 941 0021 405	IC(NJM7915FA)		1	
26	00D 958 7035 502	IC(NJM7815FA 3PIN)		1	*
27	00D 958 7014 206	FIXED PLATE FOR IC		1	
28	00D 958 7014 303	FIXED RACK(0.5t)		1	
29	00D 958 7014 002	FIXED PLATE FOR ROTARY VR		3	
30	00D 958 0045 803	BRACKET(L TYPE)		2	
31	00D 958 7039 809	CUSHION(28*4.8*0.5t)		3	*
32	00D 958 7013 702	SLEEVE(6*10.2L)		7	
33	00D 958 7038 305	SPACER SUPPORT(H-20)		4	*
34	00D 958 7038 101	SPACER SUPPORT(KCA-30)		2	*
35	00D 958 0006 004	SCREW(3*10 ZK PTP)		3	
36	00D 958 7013 605	GROUND PIN		2	
37	00D 958 7039 508	WASHER(8*3.2*1t,NI)		2	*
38	00D 958 7045 107	FOOT		4	*
40	00D 958 7038 509	REVERSIBLE PASTE(3mm)		2	*
41	00D 958 7043 400	TRANSFORMER(AC120V)	for E3	1	
41	00D 958 7043 507	TRANSFORMER(AC230V)	for E2	1	
41	00D 958 7043 604	TRANSFORMER(AC100V)	for JP	1	
42	00D 958 7038 004	SPREAD BOARD		1	*
43	00D 958 7037 500	RCA ADAPTOR PLUG(A028)		4	*
44	00D 958 7039 605	CUSHION(PORON,10*8*5t)		3	*
45	00D 958 7038 606	NUT(M3*P0.5)		2	*
46	00D 958 7038 800	SCREW(CTF,3*7)		12	*
47	00D 958 7039 207	SCREW(ISO,F,3*4,ZS)		6	*
48	00D 958 7039 100	SCREW(BTB,3*5,ZB)		32	*
49	00D 958 7039 003	SCREW(2.6*5)		4	*
50	00D 958 0001 902	SCREW(2.6*4 P=0.45)		2	
51	00D 958 7038 907	SCREW(M3*P0.5*5L)		27	*
52	00D 958 7038 703	SCREW(M3*8,P=0.5,BLACK)		8	*

PACKING VIEW

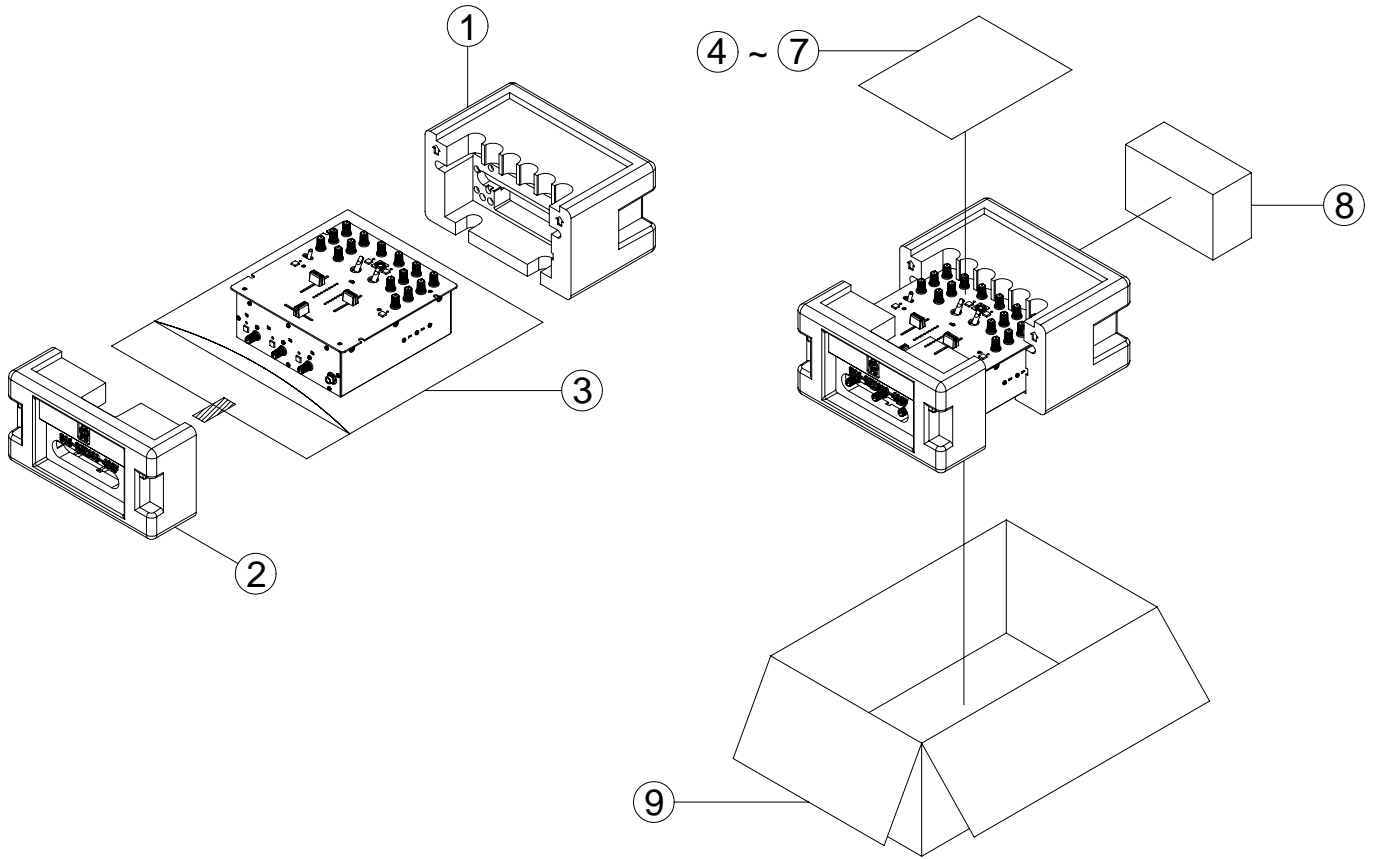

PARTS LIST OF PACKING & ACCESSORIES

*本表に記載されている部品は、補修用部品のため製品に使用している部品とは一部、形状、寸法などが異なる場合があります。

Note: The symbols in the column "Remarks" indicate the following destinations.

E3: U.S.A. & Canada model E2: Europe model EK: U.K. model E2A: Asia model
 E1C: China model EUT: Taiwan R.O.C. model E1K: Korea model JP: Japan model

	Ref. No.	Part No.	Part Name	Remarks	Q'ty	New
	1	00D 958 7044 302	POLYFOAM B		1	*
	2	00D 958 7044 409	POLYFOAM F		1	*
	3	00D 958 7044 904	SOFT BAG		1	*
	4	00D 958 0039 505	POLY COVER		1	
	5	00D 958 7043 808	INST. MANUAL	for E3,E2	1	*
	5	00D 958 7043 701	INST. MANUAL	for JP	1	*
	6	00D 515 0923 304	S.S.LIST	for E3,E2	1	
	6	00D 515 0918 209	S.S.LIST	for JP	1	
	7	00D 515 0966 109	WARRANTEE	for E3	1	
	8	00D 958 7043 400	TRANSFORMER(AC120V)	for E3	1	*
⚠	8	00D 958 7043 507	TRANSFORMER(AC230V)	for E2	1	*
⚠	8	00D 958 7043 604	TRANSFORMER(AC100V)	for JP	1	*
⚠	9	00D 958 7044 603	GIFT BOX(480*294*163mm)	for E3,E2	1	*
	9	00D 958 7044 506	GIFT BOX(480*294*163mm)	for JP	1	*
	★ 10	00D 515 0919 004	GUARANTEE CARD(S)	for JP	1	
	★ 11	00D 958 7019 007	POS LABEL	for JP	1	*

NOTE FOR SCHEMATIC DIAGRAM

WARNING:

Parts marked with this symbol \triangle have critical characteristics. Use ONLY replacement parts recommended by the manufacturer.

CAUTION:

Before returning the unit to the customer, make sure you make either (1) a leakage current check or (2) a line to chassis resistance check. If the leakage current exceeds 0.5 milliamps, or if the resistance from chassis to either side of the power cord is less than 460 kohms, the unit is defective.

WARNING:

DO NOT return the unit to the customer until the problem is located and corrected.

NOTICE:

ALL RESISTANCE VALUES IN OHM. k=1,000 OHM
M=1,000,000 OHM
ALL CAPACITANCE VALUES IN MICRO FARAD.
P=MICRO-MICRO FARAD
EACH VOLTAGE AND CURRENT ARE MEASURED AT
NO SIGNAL INPUT CONDITION.
CIRCUIT AND PARTS ARE SUBJECT TO CHANGE
WITHOUT PRIOR NOTICE.

配線図について

\triangle 印の部品は安全を維持するために重要な部品です。従って交換時は必ず指定の部品を使用してください。

注)

- (1) 指定なき抵抗値は Ω 、k は k Ω 、M は M Ω を示す。
- (2) 指定なきコンデンサーの値は μF 、p は pF を示す。
- (3) 各部の電圧は無信号の値を示す。
- (4) この配線図は基本配線図です。改良等のため変更することがありますのでご了承ください。

SCHEMATIC DIAGRAMS (1/3)

1 2 3 4 5 6 7 8 9 10 11

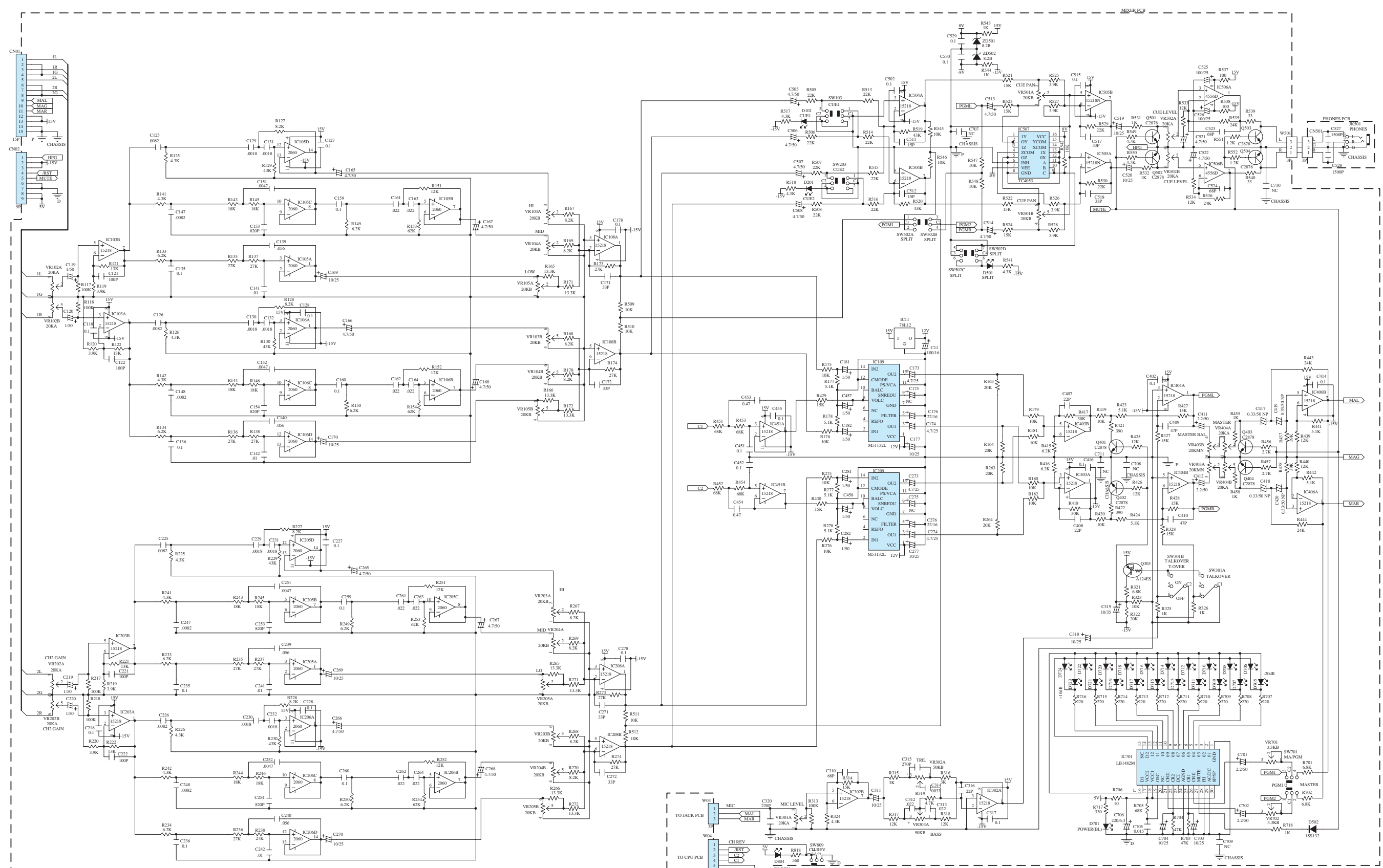

SCHEMATIC DIAGRAMS (1/3)
MIXER UNIT
PHONE UNIT
CROSSFADE UNIT

SCHEMATIC DIAGRAMS (2/3)

1 2 3 4 5 6 7 8 9 10 11

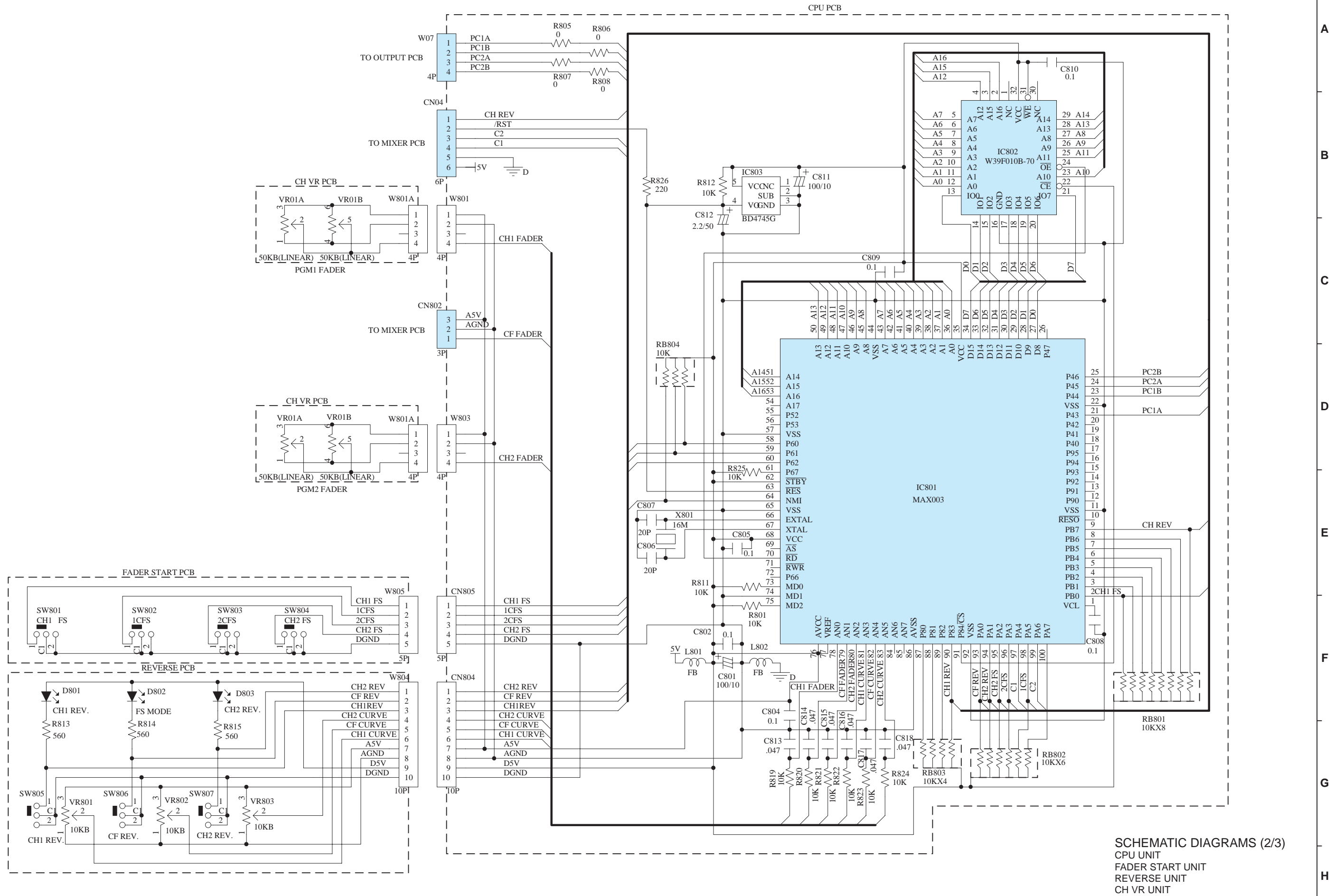

SCHEMATIC DIAGRAMS (2/3)
 CPU UNIT
 FADER START UNIT
 REVERSE UNIT
 CH VR UNIT

A
B
C
D
E
F
G
H

SCHEMATIC DIAGRAMS (3/3)

1 2 3 4 5 6 7 8 9 10 11

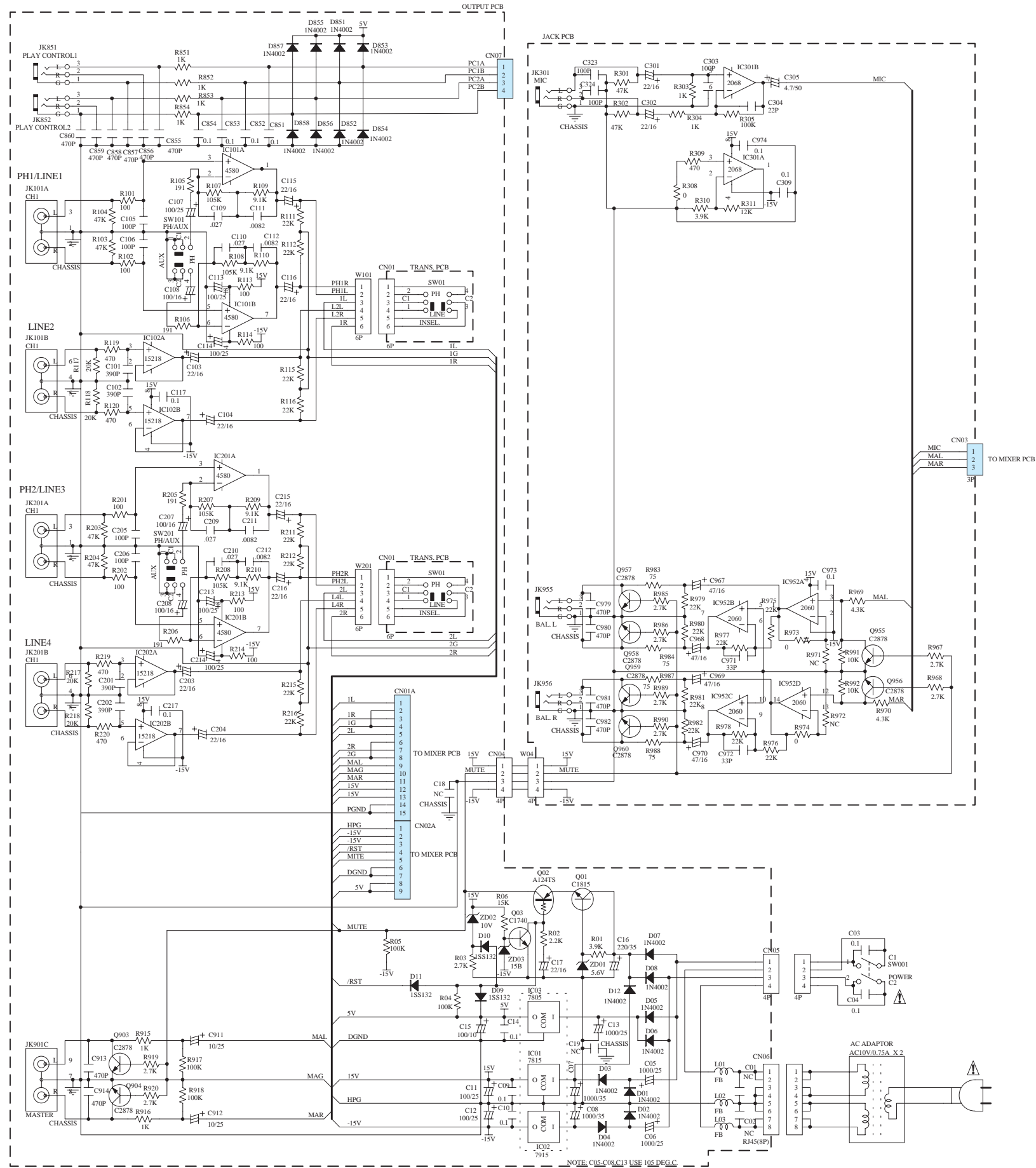

SCHEMATIC DIAGRAMS (3/3)
OUTPUT UNIT
JACK UNIT
TRANS UNIT

A
B
C
D
E
F
G
H