

DENON

For U.S.A., Canada, Europe, U.K.,
Asia, China, Taiwan R.O.C., Korea
& Japan model

Ver. 1

SERVICE MANUAL

MODEL DN-X300

DJ MIXER

注意

サービスをおこなう前に、このサービスマニュアルを必ずお読みください。本機は、火災、感電、けがなどに対する安全性を確保するために、さまざまな配慮をおこなっており、また法的には「電気用品安全法」にもとづき、所定の許可を得て製造されております。従ってサービスをおこなう際は、これらの安全性が維持されるよう、このサービスマニュアルに記載されている注意事項を必ずお守りください。

● For purposes of improvement, specifications and design are subject to change without notice.

● 本機の仕様は性能改良のため、予告なく変更することがあります。
● 補修用性能部品の保有期間は、製造打切後8年です。

● Please use this service manual with referring to the operating instructions without fail.

● 修理の際は、必ず取扱説明書を参照の上、作業を行ってください。

● Some illustrations using in this service manual are slightly different from the actual set.

● 本文中に使用しているイラストは、説明の都合上現物と多少異なる場合があります。

DENON, Ltd.

TOKYO, JAPAN

SAFETY PRECAUTIONS

The following check should be performed for the continued protection of the customer and service technician.

LEAKAGE CURRENT CHECK

Before returning the unit to the customer, make sure you make either (1) a leakage current check or (2) a line to chassis resistance check. If the leakage current exceeds 0.5 milliamps, or if the resistance from chassis to either side of the power cord is less than 460 kohms, the unit is defective.

注意

サービス、点検時には次のことにご注意願います。

●注意事項をお守りください！

サービスのとき特に注意を必要とする個所については、キャビネット、部品、シャーシなどにラベルや捺印で、注意事項を表示しています。これらの注意書きおよび取扱説明書などの注意事項を必ずお守りください。

●感電に注意！

- (1) このセットは、交流電圧が印加されていますので、通電時に内部金属部に触れると感電することがあります。従って通電サービス時には、絶縁トランスの使用や手袋の着用、部品交換には、電源プラグを抜くなどして、感電にご注意ください。
- (2) 内部には、高電圧の部分がありますので、通電時の取扱には、十分ご注意ください。

●指定部品の使用！

セットの部品は難燃性や耐電圧など安全上の特性を持ったものとなっています。従って交換部品は、使用されていたものと同じ特性の部品を使用してください。特に配線図、部品表に△印で指定されている安全上重要な部品は必ず指定のものをご使用ください。

- ### ●部品の取付けや配線の引きまわしは、元どおりに！
- 安全上、テープやチューブなどの絶縁材料を使用したり、プリント基板から浮かして取付けた部品があります。また内部配線は引きまわしやクランプによって発熱部品や高圧部品に接近しないように配慮されていますので、これらは必ず元どおりにしてください。

●サービス後は安全点検を！

サービスのために取り外したねじ、部品、配線などが元どおりになっているか、またサービスした個所の周辺を劣化させてしまったところがないかなどを点検し、外部金属端子部と、電源プラグの刃の間の絶縁チェックをおこなうなど、安全性が確保されていることを確認してください。

(絶縁チェックの方法)

電源コンセントから電源プラグを抜き、アンテナや、プラグなどを外し、電源スイッチを入れます。500V絶縁抵抗計を用いて、電源プラグのそれぞれの端子と、外部露出金属部〔アンテナ端子、ヘッドホン端子、マイク端子、入力端子など〕との間で、絶縁抵抗値が1MΩ以上であること、この値以下のときは、セットの点検修理が必要です。

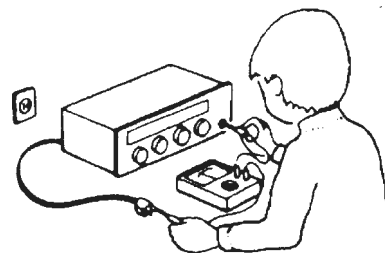

注意 安全上重要な部品について

本機に使用している多くの電気部品、および機構部品は安全上、特別な特性を持っています。この特性はほとんどの場合、外観では判別つきにくく、また、もとの部品より高い定格（定格電力、耐圧）を持ったものを使用しても安全性が維持されるとは、限りません。安全上の特性を持った部品は、このサービスマニュアルの配線図、部品表につきのように表示していますので、必ず指定されている部品番号のものを使用願います。

(1)配線図… △マークで表示しています。

(2)部品表… △マークで表示しています。
指定された部品と異なるものを使用した場合には、感電、火災などの危険を生じる恐れがあります。

DISASSEMBLY

(Follow the procedure below in reverse order when reassembling.)

1. Top Panel

- (1) Pull out the Knobs from the Top Panel.
- (2) Remove the 6 screws attaching the Top Panel.
- (3) Pull up the Front Panel.

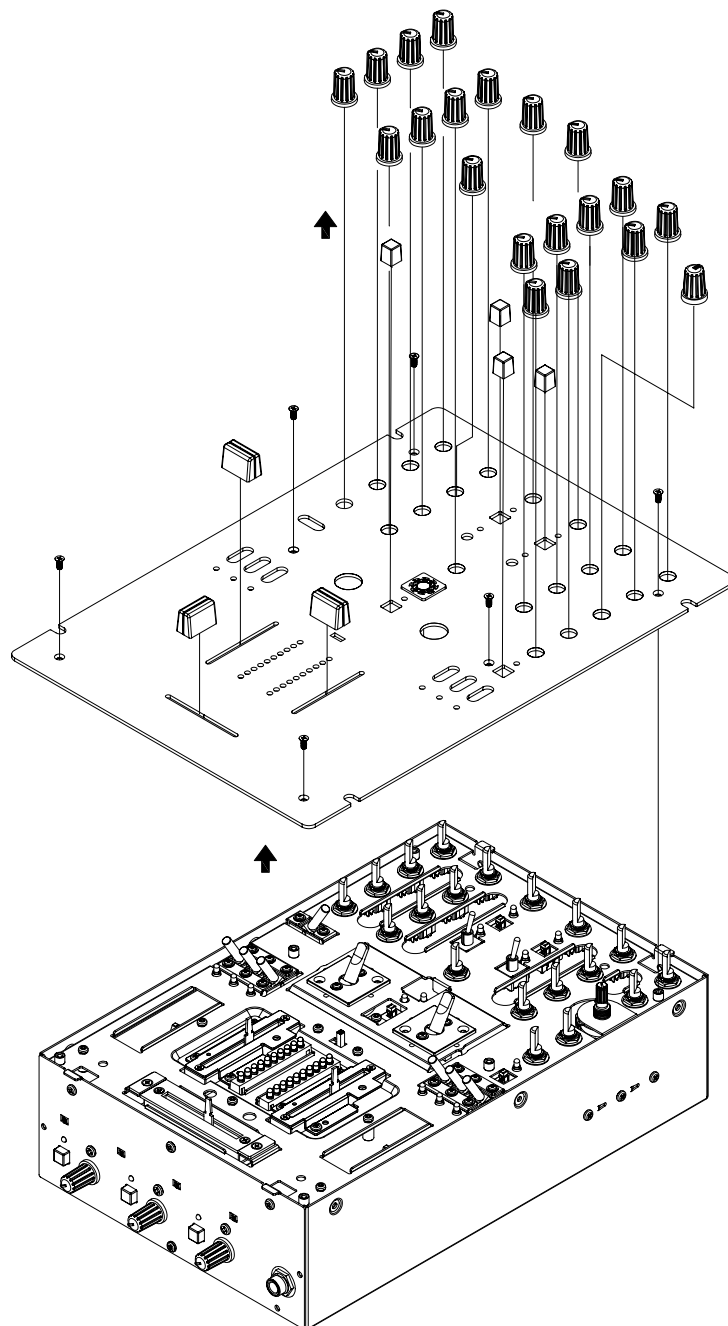

Note:

- Be careful in the attachment direction.

2. Crossfader Unit

- (1) Remove the 2 screws attaching the Crossfader Unit.
- (2) Pull up the Crossfader Unit and disconnect the connector.

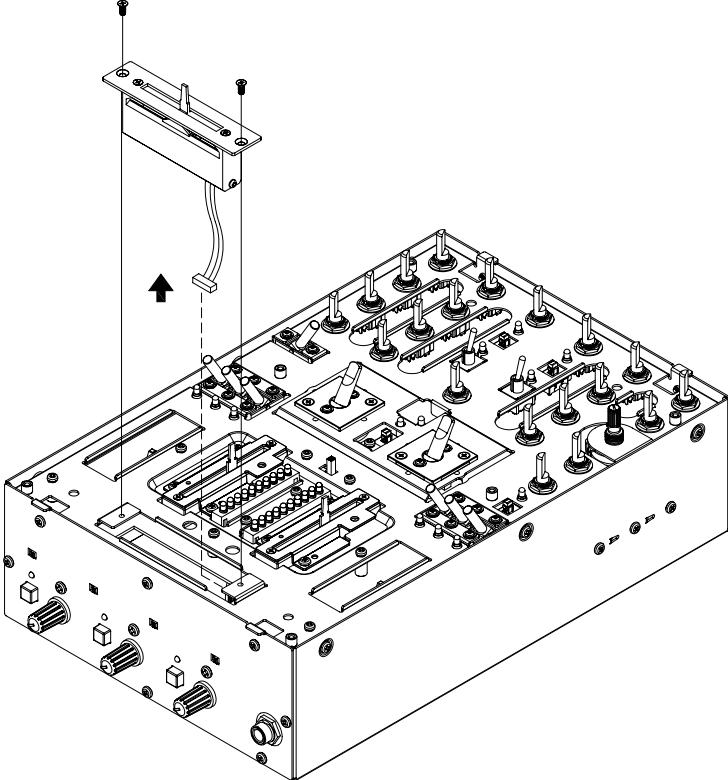

Note:
● Be careful in the attachment direction.

3. Channel Fader Unit

- (1) Remove the 3 screws attaching the Channel Fader Unit.
- (2) Pull up the Channel Fader Unit and disconnect the connector.

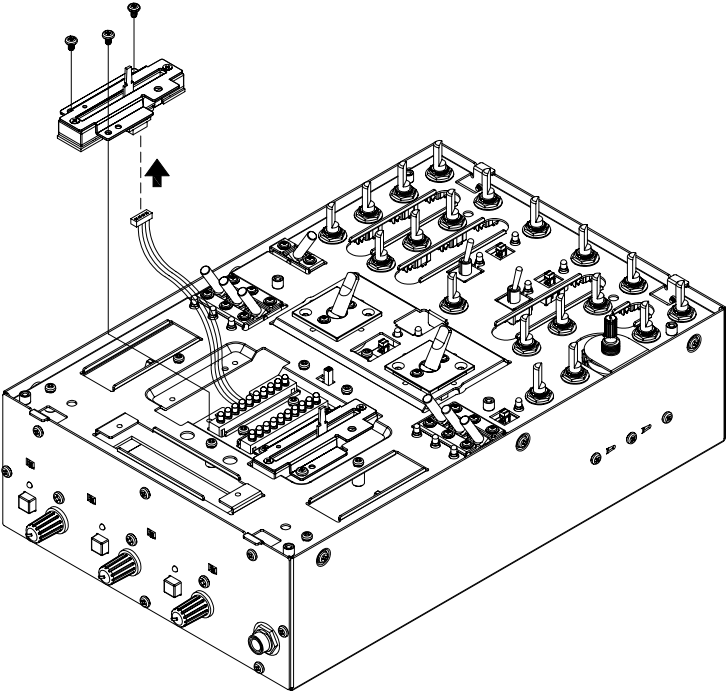

4. Input Selector Unit

- (1) Remove the 2 screws attaching the Input Selector Unit.
- (2) Pull up the Input Selector Unit and disconnect the connector.

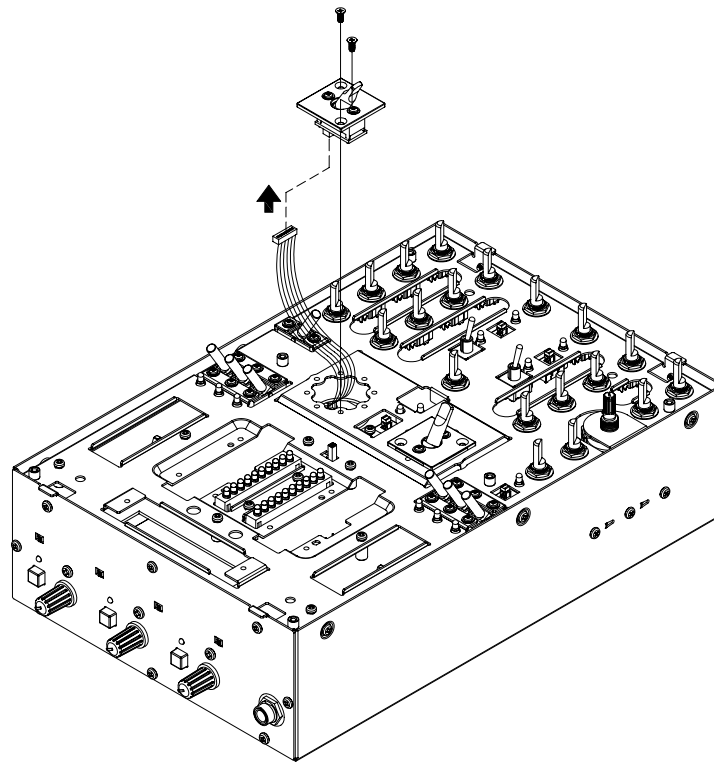

Note:
● Be careful in the attachment direction.

5. Top Panel Unit

- (1) Remove the 6 screws from the both-sides side.
- (2) Remove the 2 screws from the rear side.
- (3) Remove the 5 screws from the front side.
- (4) Remove the 4 screws from the bottom side.
- (5) Pull up the front side of the Top Unit.
- (6) Disconnect the connectors.

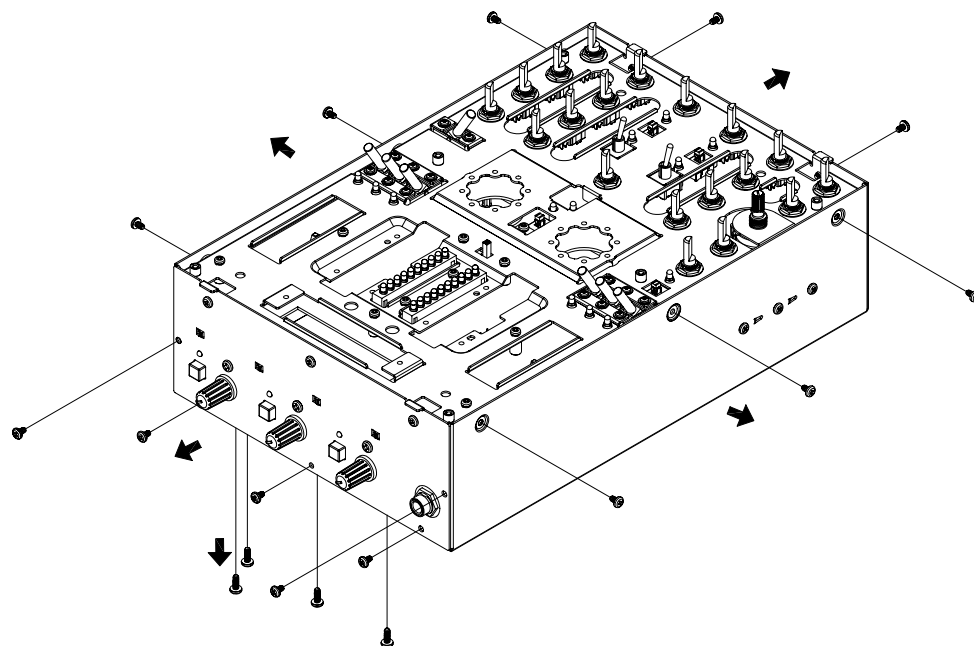

BLOCK DIAGRAM

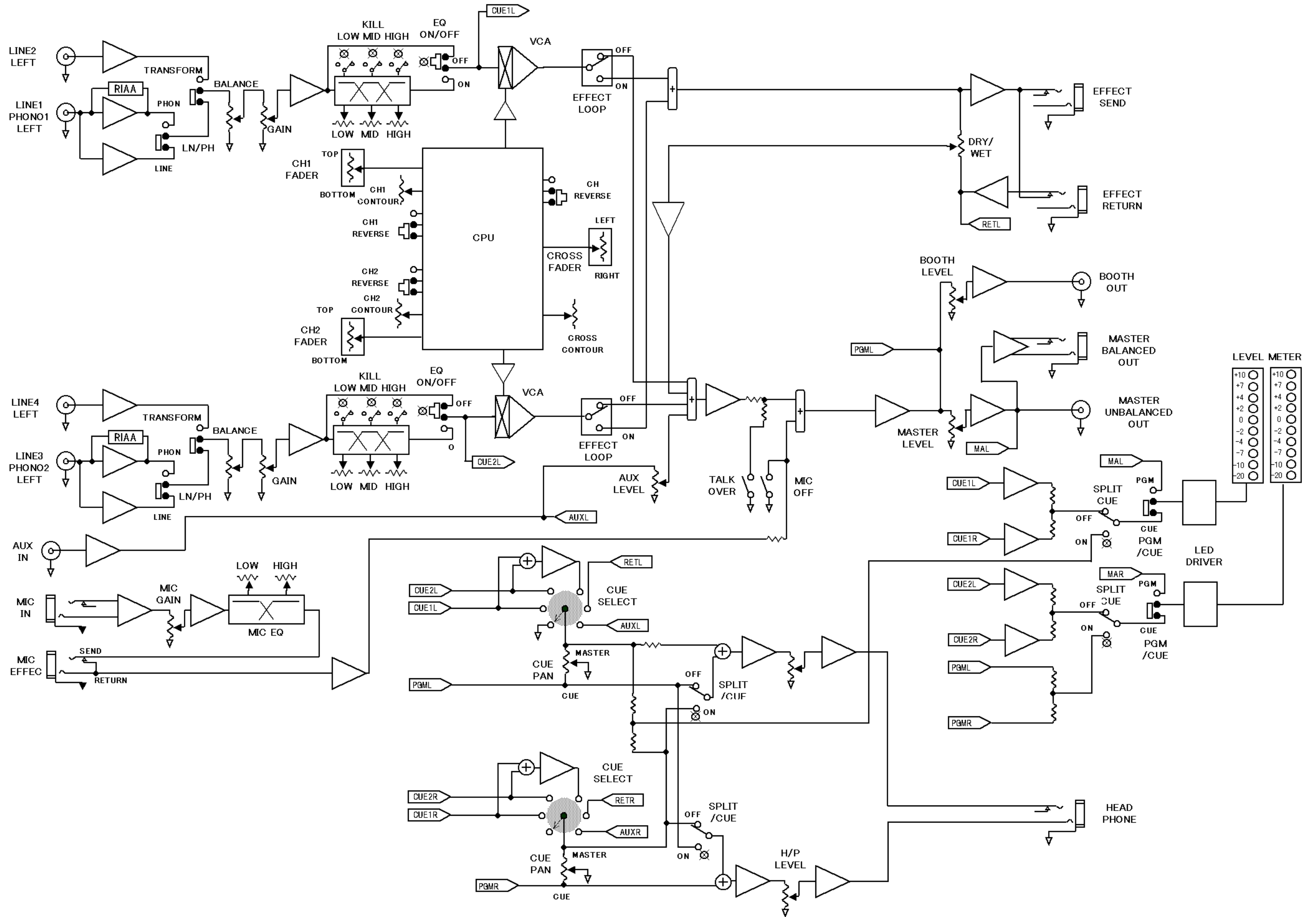

SEMICONDUCTORS / 半導体一覧表

Only major semiconductors are shown, general semiconductors etc. are omitted to list.
 主な半導体を記載しています。汎用の半導体は記載を省略しています。

1. IC's

MAX003 (IC801)

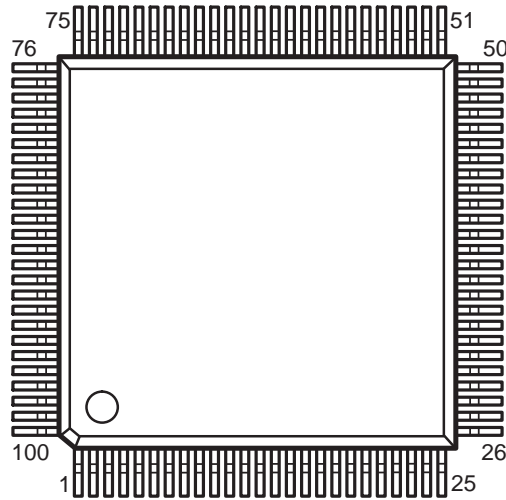

MAX003 Terminal Function

Pin No.	Pin Name	Symbol	I/O	Det	Int Pu	Ext	Res	Ini	Function
1	VCL	VCL	-	-	-	-	-	-	VCL(capacitor between this pin and GND)in 5V operation models,and as Vcc in 3V operation models.
2	PB0	CH1FS	I	-	-	Pu	L	H	CH1 FADER START SW 'L': ON
3	PB1	PB1	O	-	-	Pu	L	L	Not used
4	PB2	PB2	O	-	-	Pu	L	L	Not used
5	PB3	PB3	O	-	-	Pu	L	L	Not used
6	PB4	PB4	O	-	-	Pu	L	L	Not used
7	PB5	PB5	O	-	-	Pu	L	H	Not used
8	PB6	FX2SW	I	-	-	Pu	L	H	PGM2 EFFECT LOOP ON/OFF SW 'L': ON (DN-X300 only)
9	PB7	CHREV	I	-	-	Pu	L	H	CH REVERSE SW 'L': ON
10	_RESO	_RESO	O	-	-	-	-	-	Not used
11	Vss	Vss	-	-	-	-	-	-	GND(0V)
12	P90	P90	O	-	-	-	L	L	Not used
13	P91	P91	O	-	-	-	L	L	Not used
14	P92	P92	O	-	-	-	L	L	Not used
15	P93	P93	O	-	-	-	L	L	Not used
16	P94	P94	O	-	-	-	L	L	Not used
17	P95	P95	O	-	-	-	L	L	Not used
18	P40	P40	O	-	ON	-	L	L	Not used
19	P41	P41	O	-	ON	-	L	L	Not used
20	P42	P42	O	-	ON	-	L	L	Not used
21	P43	PC1A	I/O	-	ON	-	L	H	PGM1 Fader PLAY output 30msec 'L' pulse
22	Vss	Vss	-	-	-	-	-	-	GND(0V)
23	P44	PC1B	I/O	-	ON	-	L	H	PGM1 Fader CUE output 30msec 'L' pulse
24	P45	PC2A	I/O	-	ON	-	L	H	PGM2 Fader PLAY output 30msec 'L' pulse
25	P46	PC2B	I/O	-	ON	-	L	H	PGM2 Fader CUE output 30msec 'L' pulse
26	P47	P47	O	-	ON	-	L	L	Not used
27	D8	D0	D/I	-	-	-	-	-	Data bus
28	D9	D1	D/I	-	-	-	-	-	Data bus
29	D10	D2	D/I	-	-	-	-	-	Data bus
30	D11	D3	D/I	-	-	-	-	-	Data bus
31	D12	D4	D/I	-	-	-	-	-	Data bus
32	D13	D5	D/I	-	-	-	-	-	Data bus

Pin No.	Pin Name	Symbol	I/O	Det	Int Pu	Ext	Res	Ini	Function
33	D14	D6	D/I	-	-	-	-	-	Data bus
34	D15	D7	D/I	-	-	-	-	-	Data bus
35	Vcc	Vcc	-	-	-	-	-	-	Power supply(+5V)
36	A0	A0	A/O	-	-	-	-	-	Address bus
37	A1	A1	A/O	-	-	-	-	-	Address bus
38	A2	A2	A/O	-	-	-	-	-	Address bus
39	A3	A3	A/O	-	-	-	-	-	Address bus
40	A4	A4	A/O	-	-	-	-	-	Address bus
41	A5	A5	A/O	-	-	-	-	-	Address bus
42	A6	A6	A/O	-	-	-	-	-	Address bus
43	A7	A7	A/O	-	-	-	-	-	Address bus
44	Vss	Vss	-	-	-	-	-	-	GND(0V)
45	A8	A8	A/O	-	-	-	-	-	Address bus
46	A9	A9	A/O	-	-	-	-	-	Address bus
47	A10	A10	A/O	-	-	-	-	-	Address bus
48	A11	A11	A/O	-	-	-	-	-	Address bus
49	A12	A12	A/O	-	-	-	-	-	Address bus
50	A13	A13	A/O	-	-	-	-	-	Address bus
51	A14	A14	A/O	-	-	-	-	-	Address bus
52	A15	A15	A/O	-	-	-	-	-	Address bus
53	A16	A16	A/O	-	-	-	-	-	Address bus
54	A17	A17	A/O	-	-	-	-	-	Address bus
55	P52	_FX1ON	O	-	ON	-	L	H	PGM1 EFFECT LOOP enabler 'L': enabler (DN-X300 only)
56	P53	_FX2ON	O	-	ON	-	L	H	PGM2 EFFECT LOOP enabler 'L': enabler (DN-X300 only)
57	Vss	Vss	-	-	-	-	-	-	GND(0V)
58	P60	LEDFX1	O	-	-	Pu	L	H	PGM1 EFFECT LOOP LED control. (DN-X300 only)
59	P61	LEDFX2	O	-	-	Pu	L	H	PGM2 EFFECT LOOP LED control. (DN-X300 only)
60	P62	FX1SW	I	-	-	-	L	H	PGM1 EFFECT LOOP ON/OFF SW 'L': ON (DN-X300 only)
61	P67	P67	I	-	-	-	H	H	DN-X100/300 program selected Pin 'L': DN-X300
62	_STBY	_STBY	-	-	-	-	-	H	When driven low,this pin forces a transition to hardware standby mode.
63	_RES	_RES	-	-	-	-	-	-	Reset signal 'L': Reset
64	NMI	NMI	I	-	-	Pu	-	H	Not used
65	Vss	Vss	-	-	-	-	-	-	GND(0V)
66	EXTAL	EXTAL	-	-	-	-	-	-	OSC 16MHz
67	XTAL	XTAL	-	-	-	-	-	-	OSC 16MHz
68	Vcc	Vcc	-	-	-	-	-	-	Power supply(+5V)
69	_AS	_AS	-	-	-	-	-	-	Not used
70	_RD	_RD	O	-	-	-	-	-	Goes low to indicate reading from the external address space
71	_HWR	_HWR	-	-	-	-	-	-	Not used
72	P66	JDET	I	-	-	-	L	H	Check Send Return jack inserted
73	MD0	MD0	I	-	-	-	-	-	IC Operating mode control
74	MD1	MD1	I	-	-	-	-	-	IC Operating mode control
75	MD2	MD2	I	-	-	-	-	-	IC Operating mode control
76	Avcc	Avcc	-	-	-	-	-	-	Power supply pin for the A/D converters(+5V).
77	Vref	Vref	-	-	-	-	-	-	Reference voltage input pin for the A/D converters(+5V).
78	P70,AN0	CH1FADER	I	-	-	-	-	Hi-z	CH1 FADER VR A/D converter
79	P71,AN1	CFFADER	I	-	-	-	-	Hi-z	CROSS FADER VR A/D converter
80	P72,AN2	CH2FADER	I	-	-	-	-	Hi-z	CH2 FADER VR A/D converter
81	P73,AN3	CH1CUREV	I	-	-	-	-	Hi-z	CH1 FADER CONTOUR VR A/D converter
82	P74,AN4	CFCUREV	I	-	-	-	-	Hi-z	CROSS FADER CONTOUR VR A/D converter
83	P75,AN5	CH2CUREV	I	-	-	-	-	Hi-z	CH2 FADER CONTOUR VR A/D converter
84	P76,AN6	AN6	I	-	-	-	-	Hi-z	Not used
85	P77,AN7	AN7	I	-	-	-	-	Hi-z	Not used
86	Avss	Avss	-	-	-	-	-	-	Ground pin for A/D converters(0V).
87	P80	P80	O	-	-	Pu	L	L	Not used

Pin No.	Pin Name	Symbol	I/O	Det	Int Pu	Ext	Res	Ini	Function
88	P81	P81	O	-	-	Pu	L	L	Not used
89	P82	P82	O	-	-	Pu	L	L	Not used
90	P83	CH1REV	O	-	-	Pu	L	H	CH1 FADER REVERSE SW 'L' : ON
91	P84,_CS	_CE	O	-	-	-	L	L	Chip select signal.
92	Vss	Vss	-	-	-	-	-	-	GND(0V)
93	PA0	CFREV	I	-	-	Pu	L	H	CROSSFADER REVERSE SW 'L' : ON
94	PA1	CH2REV	I	-	-	Pu	L	H	CH2 FADER REVERSE SW 'L' : ON
95	PA2	CH2FS	I	-	-	Pu	L	H	CH2 FADER START SW 'L' : ON
96	PA3	2CFS	I	-	-	Pu	L	H	CROSSFADER START B SW 'L' : ON
97	PA4	C1	O	-	-	-	L	H	PWM output control PGM1 volume
98	PA5	1CFS	I	-	-	Pu	L	H	CROSSFADER START A SW 'L' : ON
99	PA6	C2	O	-	-	-	L	H	PWM output control PGM2 volume
100	PA7	PA7	O	-	-	Pu	L	L	Not used

LB1482M (IC701)

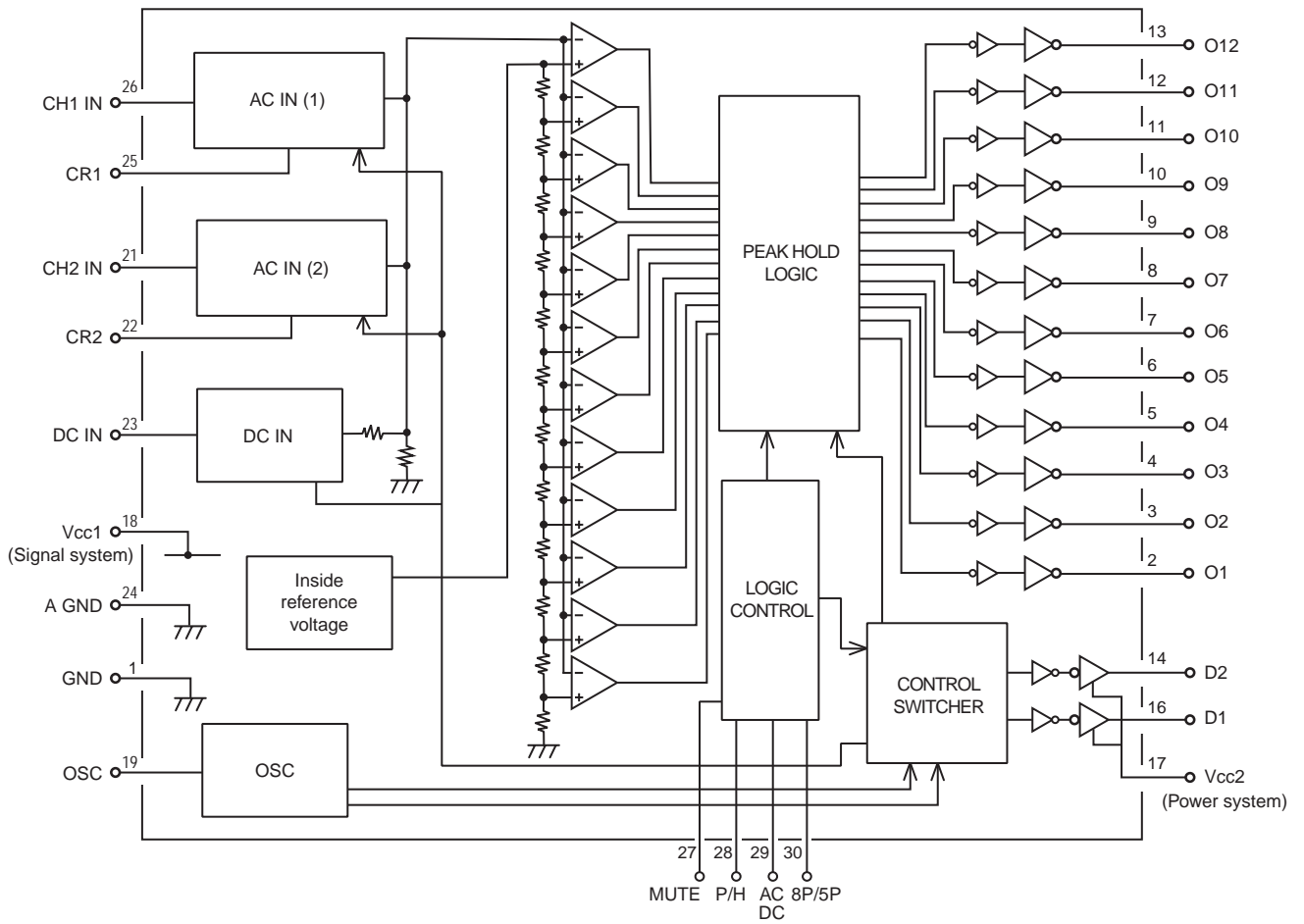
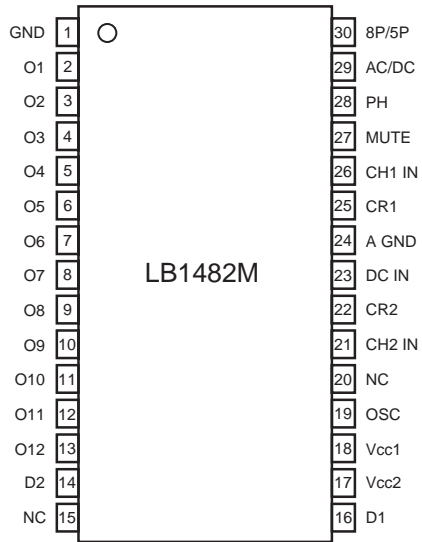

TC4053BF (IC507)

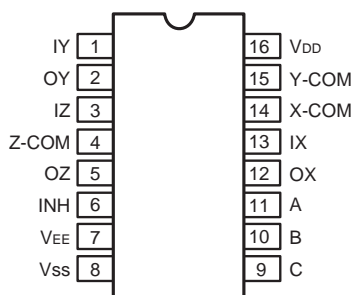

NJM2060 (IC105, 106, 205, 206, 952)

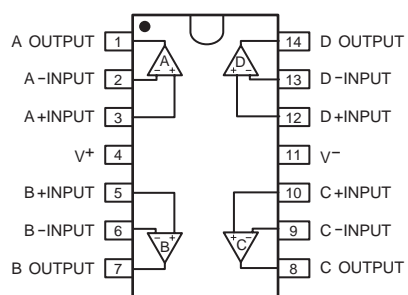

THAT2180 (IC111, 112, 211, 212)

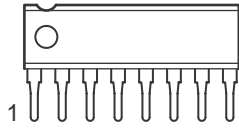

Pin Name	SIP Pin
Input	1
Ec+	2
Ec-	3
Sym	4
V-	5
Gnd	6
V+	7
Output	8

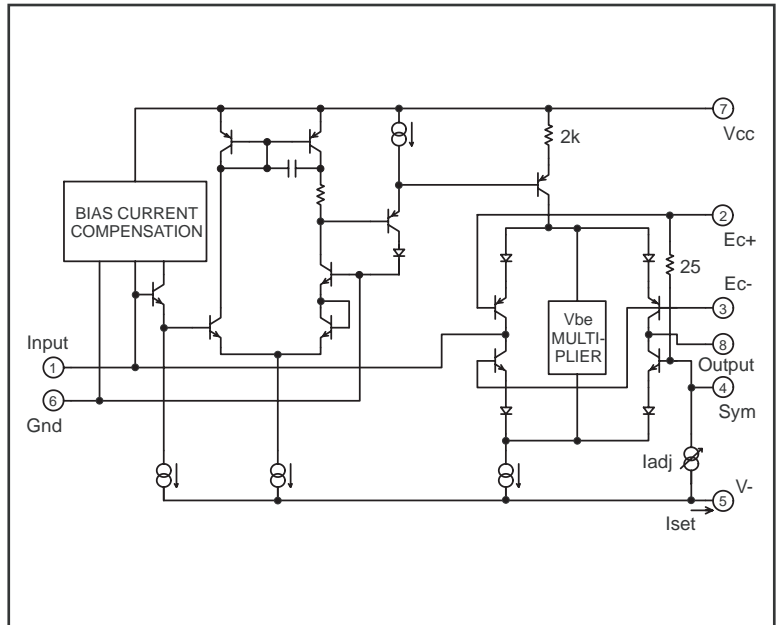

1M FLASH MEMORY (IC802)

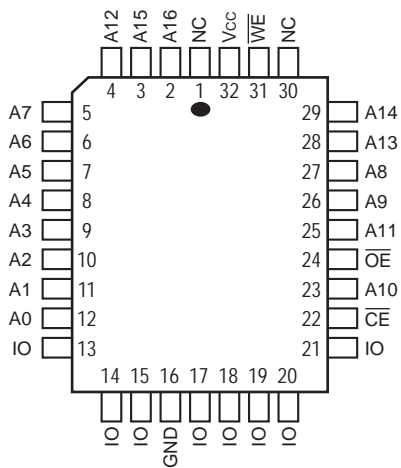

ADG212A (IC113, 213)

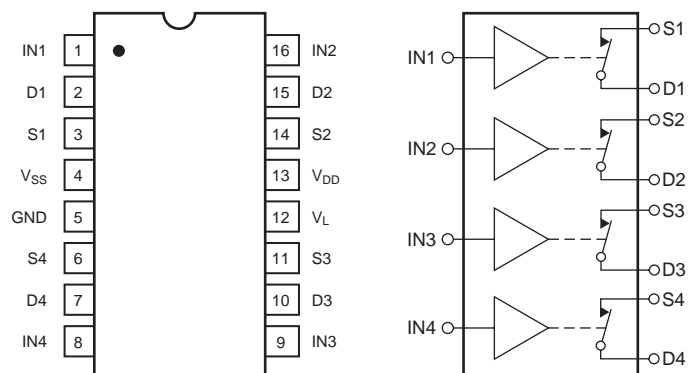

BD4745G (IC803)

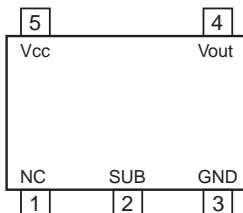

PRINTED WIRING BOARDS

MIXER P.W.B. UNIT

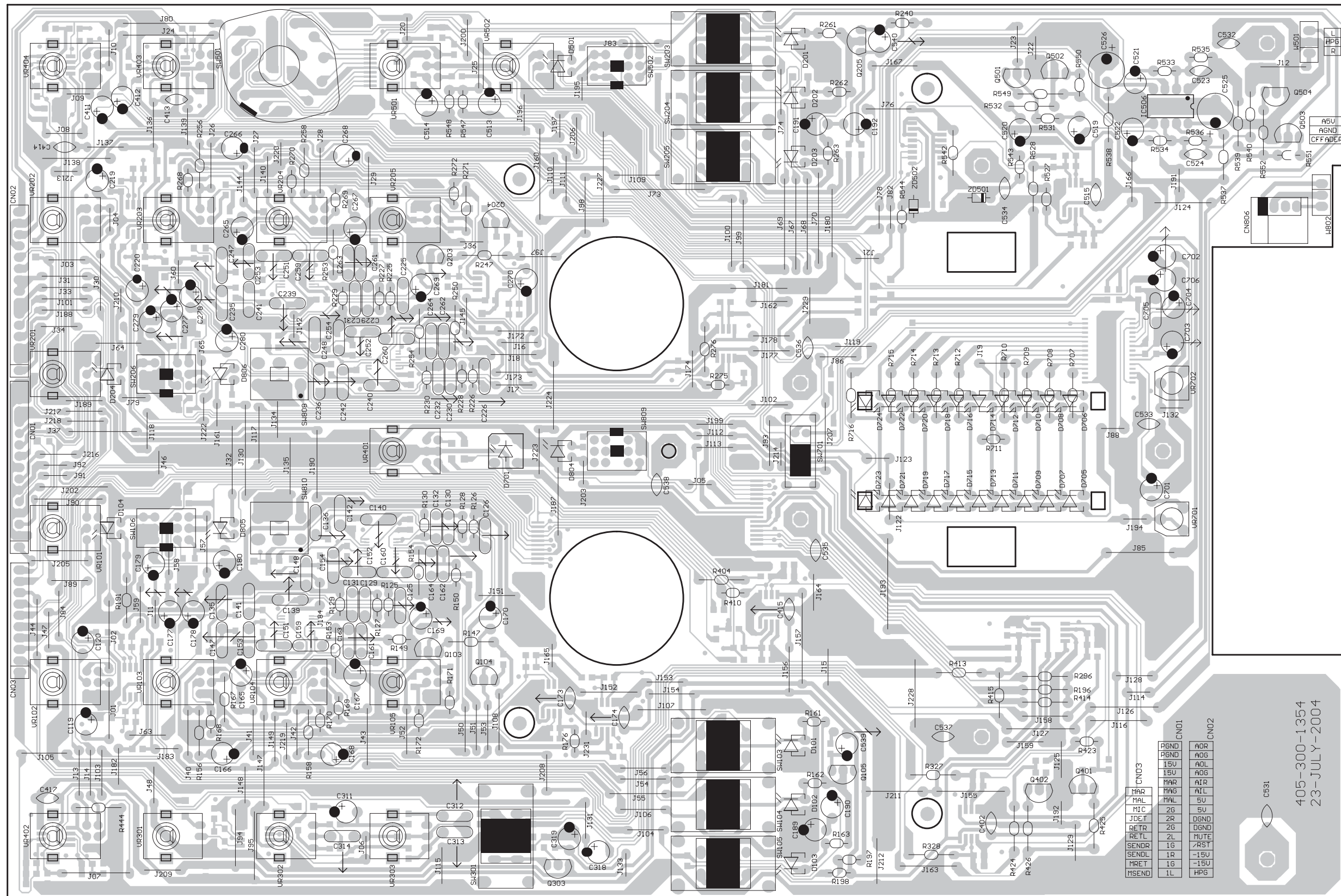

405-300-1354
23-JULY-2004

COMPONENT SIDE

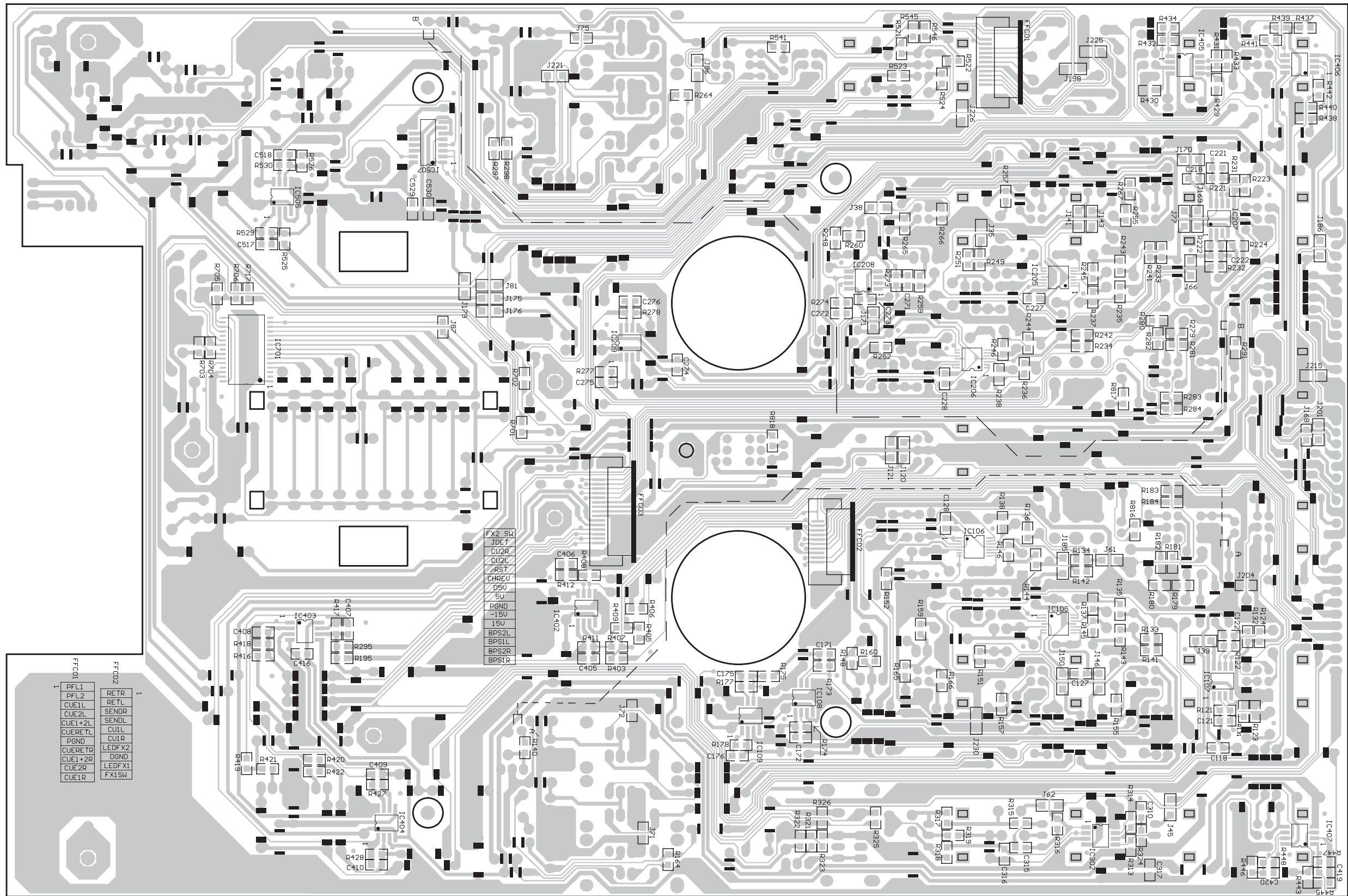

FOIL SIDE

JACK P.W.B. UNIT

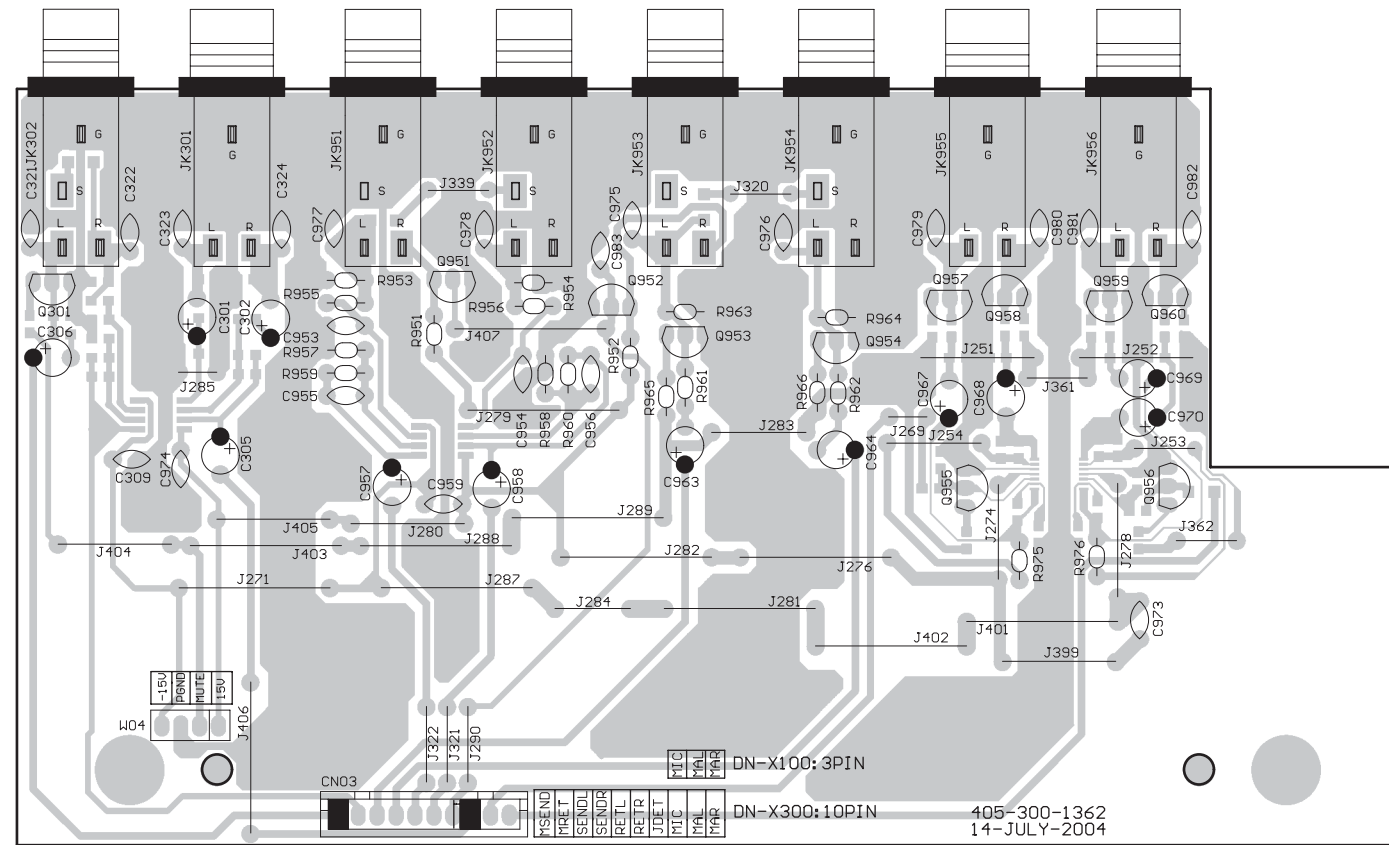

COMPONENT SIDE

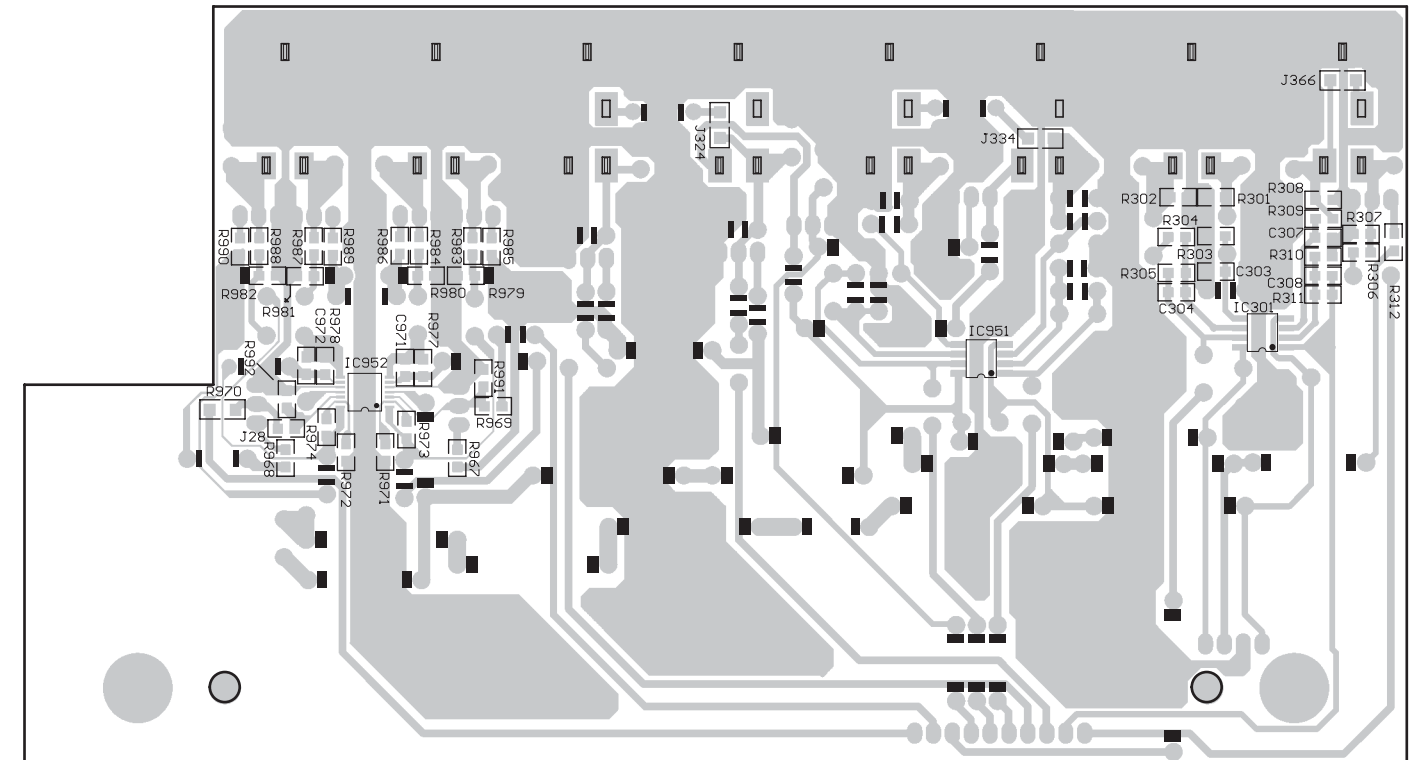

FOIL SIDE

CPU P.W.B. UNIT

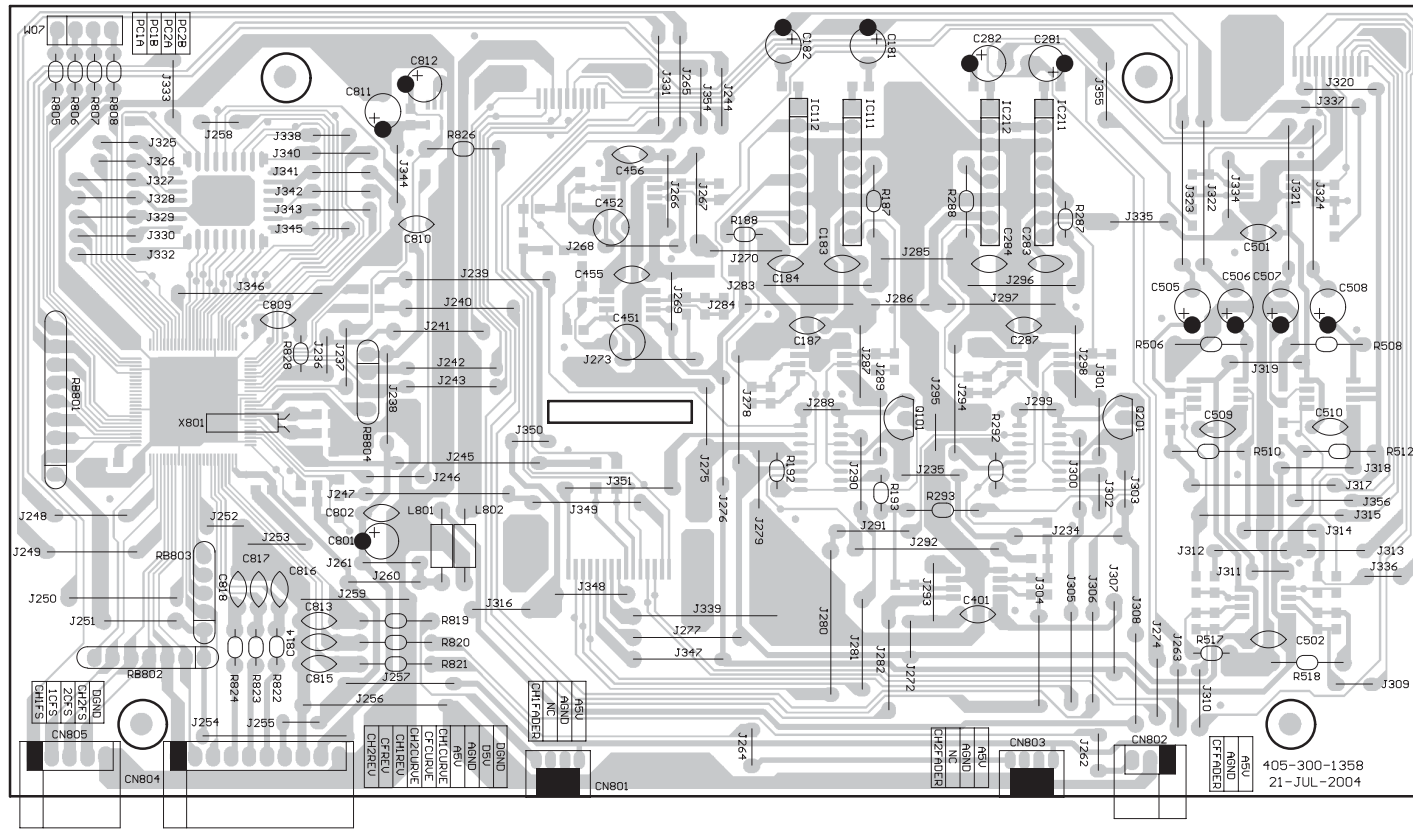

COMPONENT SIDE

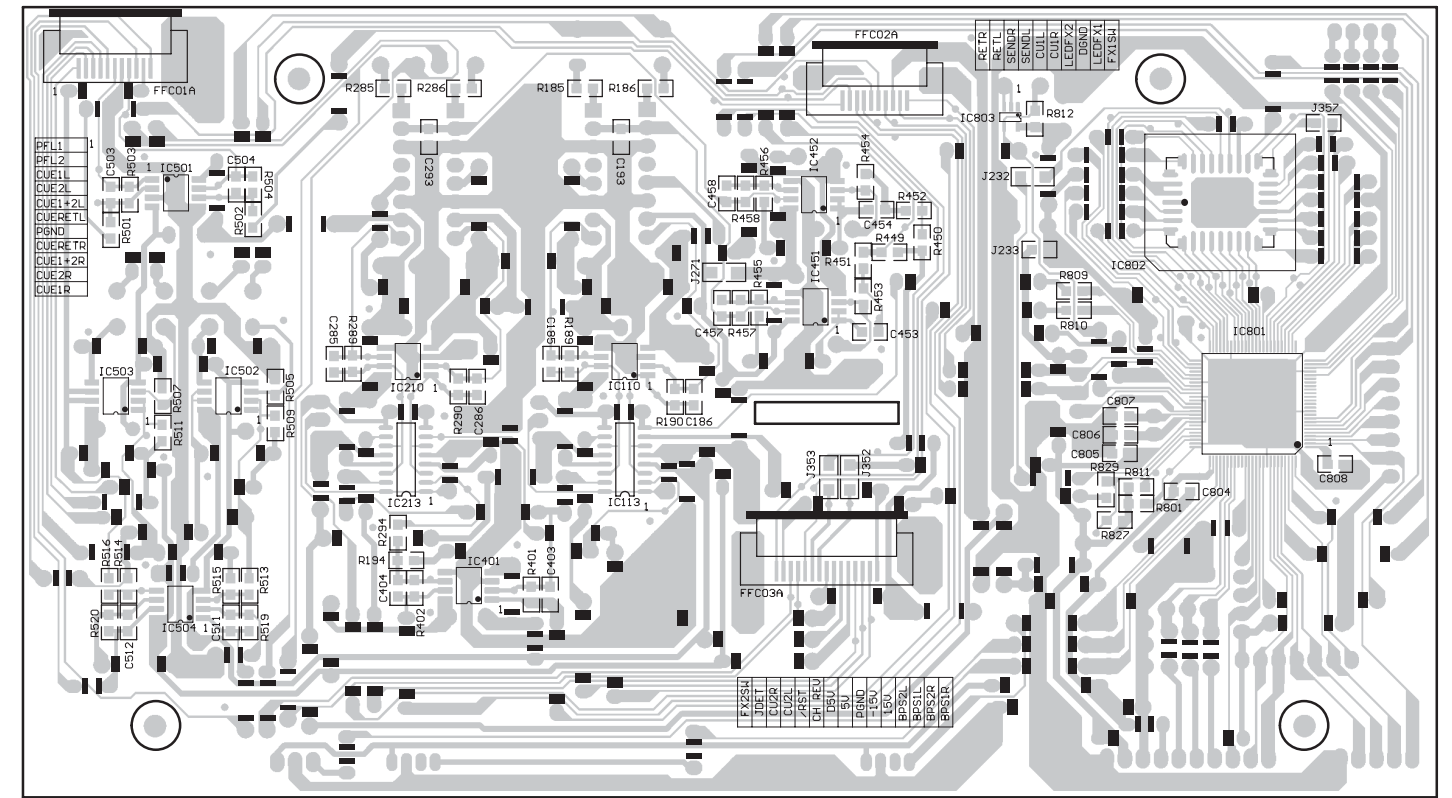

FOIL SIDE

REVERSE P.W.B. UNIT

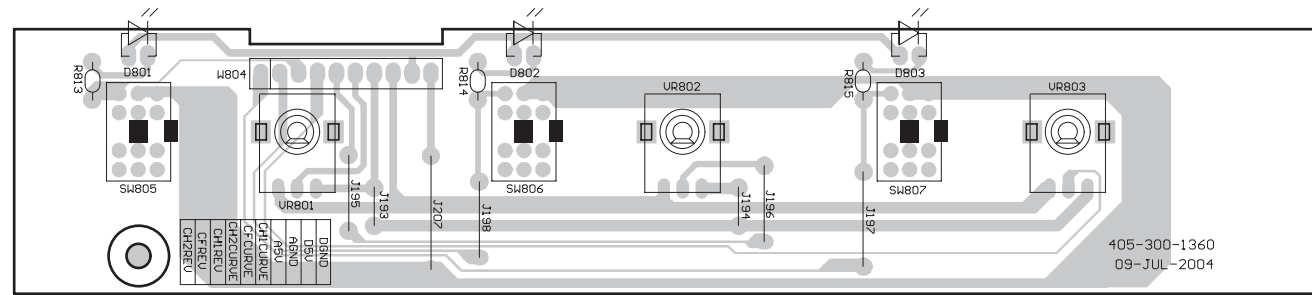

COMPONENT SIDE

PHONE P.W.B. UNIT

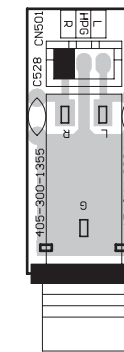

COMPONENT SIDE

FADER START P.W.B. UNIT

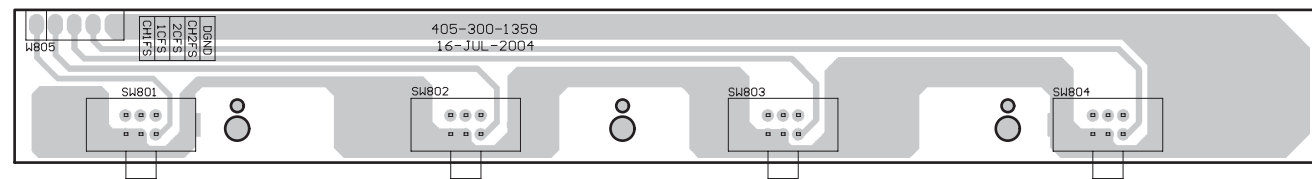

COMPONENT SIDE

CH VR P.W.B. UNIT

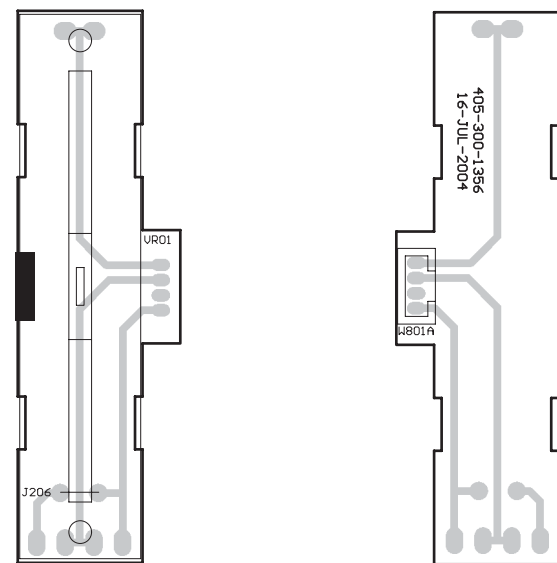

COMPONENT SIDE

FOIL SIDE

TRANS P.W.B. UNIT

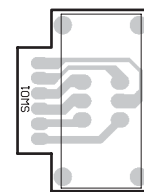

COMPONENT SIDE

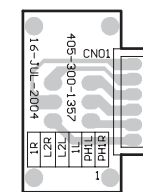

FOIL SIDE

NOTE FOR PARTS LIST

- Part indicated with the mark "◎" are not always in stock and possibly to take a long period of time for supplying, or in some case supplying of part may be refused.
- When ordering of part, clearly indicate "1" and "I" (i) to avoid mis-supplying.
- Ordering part without stating its part number can not be supplied.
- Part indicated with the mark "★" is not illustrated in the exploded view.
- Not including Carbon Film Resister ±5%, 1/4W Type in the P.W.Board parts list. (Refer to the Schematic Diagram for those parts.)
- Not including Carbon Chip Resister 1/16W Type in the P.W.Board parts list. (Refer to the Schematic Diagram for those parts.)

WARNING:

Parts marked with this symbol Δ have critical characteristics.
Use ONLY replacement parts recommended by the manufacturer.

部品表について

- 印の部品は常時在庫していませんので供給に長時間を要することがあります。
場合によっては、供給をお断りすることがあります。
- 部品を発注する際は特に数字の“1”と英字の“1”との区別をはっきり記入してください。
- 部品番号を表示していない部品は供給できません。
- Δ 印の部品は安全上重要な部品です。交換するときは、安全および性能維持のため必ず指定の部品をご使用ください。
- ★印のついている部品は分解図中には記載していません。
- カーボン抵抗器±5%、1/4W型は記載していません。定数は回路図を参照願います。
- カーボンチップ抵抗器1/16W型は記載していません。定数は回路図を参照願います。
- 部品表の抵抗器、コンデンサの品名記号の読み方は表を参照してください。

● Resistors

Ex.: **RN** **14K** **2E** **182** **G** **FR**
 Type Shape and performance Power Resistance Allowable error Others

RD : Carbon RC : Composition RS : Metal oxide film RW : Winding RN : Metal film RK : Metal mixture	2B : 1/8W 2E : 1/4W 2H : 1/2W 3A : 1W 3D : 2W 3F : 3W 3H : 5W	F : ±1% G : ±2% J : ±5% K : ±10% M : ±20%	P : Pulse-resistant type NL : Low noise type NB : Non-burning type FR : Fuse-resistor F : Lead wire forming
---	---	---	---

*** Resistance**

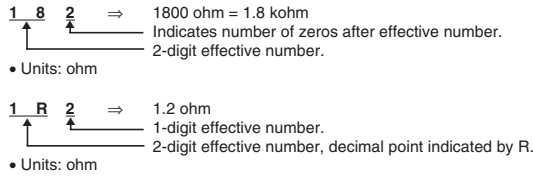

● 抵抗器

例) **RN** **14K** **2E** **182** **G** **FR**
 種類 形状特性 電力 抵抗値 許容差 その他

RD : カーボン RC : 固定体 RS : 金属系皮膜 RW : 巻線 RN : 金属皮膜 RK : 金属混合体	2B : 1/8 W 2E : 1/4 W 2H : 1/2 W 3A : 1 W 3D : 2 W 3F : 3 W 3H : 5 W	F : ±1% G : ±2% J : ±5% K : ±10% M : ±20%	P : 耐バルス形 NL : 低雑音形 NB : 不燃形 FR : ヒューズ抵抗 F : リード線成形
---	--	---	---

*** 抵抗値**

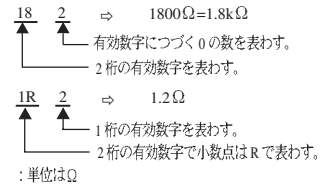

● Capacitors

Ex.: **CE** **04W** **1H** **2R2** **M** **BP**
 Type Shape and performance Dielectric strength Capacity Allowable error Others

CE : Aluminum foil electrolytic CA : Aluminum solid electrolytic CS : Tantalum electrolytic CQ : Film CK : Ceramic CC : Ceramic CP : Oil CM : Mica CF : Metallized CH : Metallized	0J : 6.3V 1A : 10V 1C : 16V 1E : 25V 1V : 35V 1H : 50V 2A : 100V 2B : 125V 2C : 160V 2D : 200V 2E : 250V 2H : 500V 2J : 630V	F : ±1% G : ±2% J : ±5% K : ±10% M : ±20% Z : +80% -20% P : +100% -0% C : ±0.25pF D : ±0.5pF = : Others	HS : High stability type BP : Non-polar type HR : Ripple-resistant type DL : For change and discharge HF : For assuring high frequency U : UL part C : CSA part W : UL-CSA type F : Lead wire forming
---	--	--	---

*** Capacity (electrolyte only)**

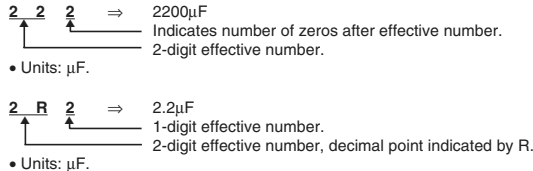

*** Capacity (except electrolyte)**

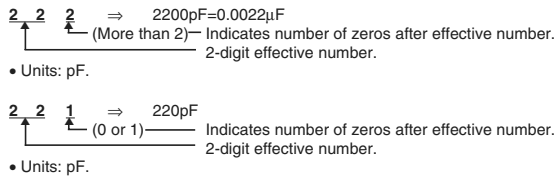

When the dielectric strength is indicated in AC, "AC" is included after the dielectric strength value.

● コンデンサ

例) **CE** **04W** **1H** **2R2** **M** **BP**
 種類 形状特性 耐圧 容量 許容差 その他

CE : アルミ箔電解 CA : アルミ固体電解 CS : タンタル電解 CQ : フィルム CK : セラミック CC : セラミック CP : オイル CM : マイカ CF : メタライズド CH : メタライズド	0J : 6.3 V 1A : 10 V 1C : 16 V 1E : 25 V 1V : 35 V 1H : 50 V 2A : 100 V 2B : 125 V 2C : 160 V 2D : 200 V 2E : 250 V 2H : 500 V 2J : 630 V	F : ±1% G : ±2% J : ±5% K : ±10% M : ±20% Z : +80% -20% P : +100% - 0%	C : ±0.25pF D : ±0.5pF = : その他	HS : 高安定形 BP : 無極性形 HR : 耐リップル形 DL : 充放電対策用 HF : 高周波保証用 U : UL 部品 C : CSA 部品 W : UL-CSA 部品 F : リード線成形
---	---	--	--------------------------------------	---

*** 容量値**

● 電解コンデンサの場合

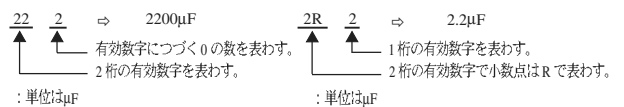

● 電解コンデンサ以外の場合

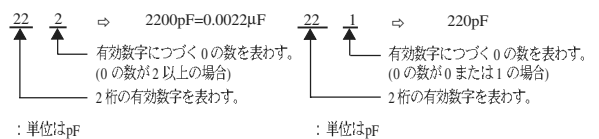

● 耐圧を交流で表示する場合は、耐圧表示の次に「AC」を表示します。

PARTS LIST OF P.W.B. UNIT

*本表に記載されている部品は、補修用部品のため製品に使用している部品とは一部、形状、寸法などが異なる場合があります

Note: The symbols in the column "Remarks" indicate the following destinations.

E3: U.S.A. & Canada model E2: Europe model EK: U.K. model E2A: Asia model
E1C: China model EUT: Taiwan R.O.C. model E1K: Korea model JP: Japan model

MIXER P.W.B. UNIT ASS'Y

Ref. No.	Part No.	Part Name	Remarks	Q'ty	New
SEMICONDUCTORS GROUP					
IC105,106	00D 958 7035 900	IC(NJM-2060V)			*
IC107-109	00D 958 7036 006	IC(BA15218F)			*
IC205,206	00D 958 7035 900	IC(NJM-2060V)			*
IC207-209	00D 958 7036 006	IC(BA15218F)			*
IC302	00D 958 7036 006	IC(BA15218F)			*
IC402-407	00D 958 7036 006	IC(BA15218F)			*
IC505	00D 958 7036 006	IC(BA15218F)			*
IC506	00D 958 7035 104	IC(NJM-4556AD)			*
IC507	00D 958 7034 804	IC(TC4053BFN)			*
IC701	00D 958 7035 201	IC(LB1482M)			*
Q103,104	00D 958 7034 707	TRANSISTOR(2SC2878-B)			*
Q105	00D 958 0040 507	TRANSISTOR(2SC1740R)			
Q203,204	00D 958 7034 707	TRANSISTOR(2SC2878-B)			*
Q205	00D 958 0040 507	TRANSISTOR(2SC1740R)			
Q303	00D 958 0040 701	TRANSISTOR(DTA124ES)			*
Q401,402	00D 958 7034 707	TRANSISTOR(2SC2878-B)			*
Q501-504	00D 958 7034 707	TRANSISTOR(2SC2878-B)			*
D101-104	00D 958 0041 700	LED (RED)			
D201-204	00D 958 0041 700	LED (RED)			
D501	00D 958 0041 700	LED (RED)			
D701	00D 958 7019 308	LED (BLUE)			
D705-716	00D 958 0041 807	LED (GREEN)			
D717-722	00D 958 0045 104	LED (YELLOW)			
D723,724	00D 958 0041 700	LED (RED)			
D804-806	00D 958 0041 700	LED (RED)			
ZD501,502	00D 958 0049 003	ZENER DIODE(MTZJ8.2-B)			
RESISTORS GROUP					
VR101	00D 958 7036 307	ROTARY VR(20KMN,RD09L124A01B)			*
VR102	00D 958 7036 404	ROTARY VR(20KA*2,RD09L12D001D)			*
VR103-105	00D 958 7036 307	ROTARY VR(20KB*2,RD09L124A01A)			*
VR201	00D 958 7036 307	ROTARY VR(20KMN,RD09L124A01B)			*
VR202	00D 958 7036 404	ROTARY VR(20KA*2,RD09L12D001D)			*
VR203-205	00D 958 7036 307	ROTARY VR(20KB*2,RD09L124A01A)			*
VR301	00D 958 7036 608	ROTARY VR(20KA,RD09L114003D)			*
VR302,303	00D 958 7036 501	ROTARY VR(50KB,RD09L114A01B)			*
VR401	00D 958 7036 705	ROTARY VR(50KB*2,RD09L12D001E)			*
VR402-404	00D 958 7036 404	ROTARY VR(20KA*2,RD09L12D001D)			*
VR501	00D 958 7036 802	ROTARY VR(20KB*2,RD09L12DA00A)			*
VR502	00D 958 7036 404	ROTARY VR(20KA*2,RD09L12D001D)			*
VR701,702	00D 958 7019 502	SEMI FIXED RESISTOR(3.3K OHM)			*

Ref. No.	Part No.	Part Name	Remarks	Q'ty	New
CAPACITORS GROUP					
C118	00D 958 7030 905	CHIP CAPACITOR(0.1uF/ 50V,Z)			*
C119,120	00D 958 7033 902	ELEC. CAPACITOR(1uF/50V,M)			*
C121,122	00D 958 7030 808	CHIP CAPACITOR(100pF/50V,J)			*
C125,126	00D 958 7032 204	POLYESTER CAPACITOR(0.0082uF/50V,J)			*
C127,128	00D 958 7030 905	CHIP CAPACITOR(0.1uF/ 50V,Z)			*
C129-132	00D 958 7032 000	POLYESTER CAPACITOR(0.0018uF/50V,J)			*
C135,136	00D 958 7033 407	POLYESTER CAPACITOR(0.1uF/100V,J)			*
C139,140	00D 958 7032 505	POLYESTER ACPACITOR(0.056uF/50V,J)			*
C141,142	00D 958 7029 806	POLYESTER CAPACITOR(0.01uF/50V,J)			*
C147,148	00D 958 7032 204	POLYESTER CAPACITOR(0.0082uF/50V,J)			*
C151,152	00D 958 0021 209	POLYESTER CAPACITOR(0.0047uF/100V,J)			*
C153,154	00D 958 7031 700	POLYESTER CAPACITOR(820pF/50V,J)			*
C159,160	00D 958 7033 407	POLYESTER CAPACITOR(0.1uF/100V,J)			*
C161-164	00D 958 7033 106	POLYESTER CAPACITOR(0.022uF/50V,J)			*
C165-168	00D 958 7032 602	ELEC. CAPACITOR(4.7uF/50V,M)			*
C169,170	00D 958 7034 008	ELEC. CAPACITOR(10uF/25V,M)			*
C171,172	00D 958 7030 206	CHIP CAPACITOR(33pF/50V,J)			*
C173,174	00D 958 7029 107	CERAMIC CAPACITOR(0.1uF/50V,Z)			*
C175,176	00D 958 7030 002	CHIP CAPACITOR(47pF/50V,J)			*
C177-180	00D 958 7034 008	ELEC. CAPACITOR(10uF/25V,M)			*
C189-192	00D 958 7034 008	ELEC. CAPACITOR(10uF/25V,M)			*
C218	00D 958 7030 905	CHIP CAPACITOR(0.1uF/ 50V,Z)			*
C219,220	00D 958 7033 902	ELEC. CAPACITOR(1uF/50V,M)			*
C221,222	00D 958 7030 808	CHIP CAPACITOR(100pF/50V,J)			*
C225,226	00D 958 7032 204	POLYESTER CAPACITOR(0.0082uF/50V,J)			*
C227,228	00D 958 7030 905	CHIP CAPACITOR(0.1uF/ 50V,Z)			*
C229-232	00D 958 7032 000	POLYESTER CAPACITOR(0.0018uF/50V,J)			*
C235,236	00D 958 7033 407	POLYESTER CAPACITOR(0.1uF/100V,J)			*
C239,240	00D 958 7032 505	POLYESTER ACPACITOR(0.056uF/50V,J)			*
C241,242	00D 958 7029 806	POLYESTER CAPACITOR(0.01uF/50V,J)			*
C247,248	00D 958 7032 204	POLYESTER CAPACITOR(0.0082uF/50V,J)			*
C251,252	00D 958 0021 209	POLYESTER CAPACITOR(0.0047uF/100V,J)			*
C253,254	00D 958 7031 700	POLYESTER CAPACITOR(820pF/50V,J)			*
C259,260	00D 958 7033 407	POLYESTER CAPACITOR(0.1uF/100V,J)			*
C261-264	00D 958 7033 106	POLYESTER CAPACITOR(0.022uF/50V,J)			*
C265-268	00D 958 7032 602	ELEC. CAPACITOR(4.7uF/50V,M)			*
C269,270	00D 958 7034 008	ELEC. CAPACITOR(10uF/25V,M)			*
C271,272	00D 958 7030 206	CHIP CAPACITOR(33pF/50V,J)			*
C273,274	00D 958 7030 905	CHIP CAPACITOR(0.1uF/ 50V,Z)			*
C275,276	00D 958 7030 002	CHIP CAPACITOR(47pF/50V,J)			*
C277-280	00D 958 7034 008	ELEC. CAPACITOR(10uF/25V,M)			*
C310	00D 958 7033 708	CHIP CAPACITOR(68pF/50V,J)			*
C311	00D 958 7034 008	ELEC. CAPACITOR(10uF/25V,M)			*
C312	00D 958 7032 301	POLYESTER CAPACITOR(0.027uF/50V,J)			*
C313	00D 958 7033 106	POLYESTER CAPACITOR(0.022uF/50V,J)			*
C314	00D 958 7033 203	POLYESTER CAPACITOR(0.0033uF/100V,J)			*
C315	00D 958 7031 506	CHIP CAPACITOR(270pF/50V,J)			*
C316	00D 958 7030 303	CHIP CAPACITOR(22pF/50V,J)			*
C317	00D 958 7030 905	CHIP CAPACITOR(0.1uF/ 50V,Z)			*
C318	00D 958 7034 008	ELEC. CAPACITOR(10uF/25V,M)			*
C319	00D 958 7030 507	ELEC. CAPACITOR(10uF/50V,M)			*
C402	00D 958 7029 107	CERAMIC CAPACITOR(0.1uF/50V,Z)			*
C405,406	00D 958 7030 206	CHIP CAPACITOR(33pF/50V,J)			*
C407,408	00D 958 7034 309	CHIP CAPACITOR(82pF/50V)			*
C409,410	00D 958 7030 002	CHIP CAPACITOR(47pF/50V,J)			*

Ref. No.	Part No.	Part Name	Remarks	Q'ty	New
C411,412	00D 958 7034 105	ELEC. CAPACITOR(22uF/16V,M)			*
C413-415	00D 958 7029 107	CERAMIC CAPACITOR(0.1uF/50V,Z)			*
C416	00D 958 7030 905	CHIP CAPACITOR(0.1uF/ 50V,Z)			*
C417	00D 958 7029 107	CERAMIC CAPACITOR(0.1uF/50V,Z)			*
C419,420	00D 958 7034 309	CHIP CAPACITOR(82pF/50V)			*
C513,514	00D 958 7032 602	ELEC. CAPACITOR(4.7uF/50V,M)			*
C515	00D 958 7029 107	CERAMIC CAPACITOR(0.1uF/50V,Z)			*
C517,518	00D 958 7030 206	CHIP CAPACITOR(33pF/50V,J)			*
C519,520	00D 958 7034 008	ELEC. CAPACITOR(10uF/25V,M)			*
C521,522	00D 958 7032 602	ELEC. CAPACITOR(4.7uF/50V,M)			*
C523,524	00D 958 7028 904	CERAMIC CAPACITOR(68pF/50V,K)			*
C525,526	00D 958 7034 202	ELEC. CAPACITOR(100uF/25V,M)			*
C529,530	00D 958 7030 905	CHIP CAPACITOR(0.1uF/ 50V,Z)			*
C539,540	00D 958 7032 806	ELEC. CAPACITOR(100uF/16V,M)			*
C701,702	00D 958 7030 701	ELEC. CAPACITOR(2.2uF/50V,M)			*
C703,704	00D 958 7034 008	ELEC. CAPACITOR(10uF/25V,M)			*
C705	00D 958 7033 009	POLYESTER CAPACITOR(0.015uF/100V,J)			*
C706	00D 958 7032 709	ELEC. CAPACITOR(220uF/10V,M)			*
OTHER PARTS GROUP					
A-A'	-	LEAD WIRE(L=200m/m RED)			*
B-B'	-	WIRE(BLACK L=170mm)			*
CN01	00D 958 7016 301	15P CONNECTOR WIRE			*
CN02	00D 958 7016 408	15P CONNECTOR WIRE			*
CN03	00D 958 7016 505	10P CONNECTOR WIRE			*
CN802B	00D 958 7015 904	4P 2.5 SOCKET(JM24188-4)			*
FFC01	00D 958 7016 806	11P FFC CONNECTOR			*
FFC02	00D 958 7017 300	10P FFC CONNECTOR(SMD)			*
FFC03	00D 958 7016 903	15P FFC CONNECTOR			*
SW103-105	00D 958 7015 506	LEVER SW(LBCR23M-20K)			*
SW106	00D 958 7014 701	PUSH SW(PSA-42E06L-O-250)			*
SW203-205	00D 958 7015 506	LEVER SW(LBCR23M-20K)			*
SW206	00D 958 7014 701	PUSH SW(PSA-42E06L-O-250)			*
SW301	00D 958 7015 205	LEVER SW(LBC23M-20K,8PIN)			*
SW501	00D 958 7014 808	ROTARY SW(SR2512-0206-20K0A)			*
SW502	00D 958 7014 701	PUSH SW(PSA-42E06L-O-250)			*
SW701	00D 958 7014 905	SW(SSH-22H03-G11-NS)			*
SW808	00D 958 7015 108	LEVEL SW(T201-T1-B2-A2)			*
SW809	00D 958 7014 701	PUSH SW(PSA-42E06L-O-250)			*
SW810	00D 958 7015 108	LEVEL SW(T201-T1-B2-A2)			*
W501	00D 958 7016 602	3P CONNECTOR WIRE			*
W802A	00D 958 7017 009	3P CONNECTOR WIRE			*
	00D 958 7013 304	LED BASE			*
	00D 958 7038 208	LED HOLDERT(LED3-12)	for D101-104		*
	00D 958 7038 208	LED HOLDERT(LED3-12)	for D201-204		*
	00D 958 7038 208	LED HOLDERT(LED3-12)	for D501		*
	00D 958 7038 208	LED HOLDERT(LED3-12)	for D804-806		*

OUTPUT P.W.B. UNIT ASS'Y

Ref. No.	Part No.	Part Name	Remarks	Q'ty	New
SEMICONDUCTORS GROUP					
IC01	00D 958 7035 502	IC(NJM7815FA)			*
IC02	00D 941 0021 405	IC(NJM7915FA)			
IC03	00D 958 0040 303	IC 7805			
IC101	00D 958 7036 200	IC(NJM-4580M)			*
IC102	00D 958 7036 006	IC(BA15218F)			*
IC201	00D 958 7036 200	IC(NJM-4580M)			*
IC202	00D 958 7036 006	IC(BA15218F)			*
IC901	00D 958 7036 006	IC(BA15218F)			*
Q01	00D 958 0040 604	TRANSISTORS(2SC3330U)			
Q02	00D 958 0040 808	TRANSISTOR(DTA124TS)			
Q901-904	00D 958 7034 707	TRANSISTOR(2SC2878-B)			*
D01-03	00D 958 7034 503	DIODE(1N4002/1N4002TA)			*
D04	00D 958 7034 406	DIODE(1N4002)			*
D05-08	00D 958 7034 503	DIODE(1N4002/1N4002TA)			*
D09-11	00D 958 0042 806	SWITCHING DIODE(1SS132/1SS133)			
D12	00D 958 7034 503	DIODE(1N4002/1N4002TA)			*
D851-856	00D 958 7034 503	DIODE(1N4002/1N4002TA)			*
D858	00D 958 7034 503	DIODE(1N4002/1N4002TA)			*
ZD01	00D 958 0016 405	ZENER DIODE(MTZJ5.6-C)			
ZD02	00D 958 7034 600	ZENER DIODE(MTZJ10-B)			*
CAPACITORS GROUP					
C05,06	00D 958 0044 105	ELEC. CAPACITOR(1000uF/25V,M)			
C07,08	00D 958 0044 202	ELEC. CAPACITOR(1000uF/35V,M)			
C09,10	00D 958 7029 107	CERAMIC CAPACITOR(0.1uF/50V,Z)			*
C11,12	00D 958 7031 904	ELEC. CAPACITOR(100uF/25V,M)			*
C13	00D 958 0044 105	ELEC. CAPACITOR(1000uF/25V,M)			
C14	00D 958 7030 905	CHIP CAPACITOR(0.1uF/ 50V,Z)			*
C15	00D 958 7029 505	ELEC. CAPACITOR(100uF/10V,M)			*
C16	00D 958 7032 107	ELEC. CAPACITOR(220uF/35V,M)			*
C17	00D 958 7032 408	ELEC. CAPACITOR(22uF/16V,M)			*
C101,102	00D 958 7031 603	CHIP CAPACITOR(390pF/50V,J)			*
C103,104	00D 958 7032 408	ELEC. CAPACITOR(22uF/16V,M)			*
C105,106	00D 958 7030 808	CHIP CAPACITOR(100pF/50V,J)			*
C107,108	00D 958 7033 601	ELEC.CAPACITOR(100uF/16V,M)			*
C109,110	00D 958 7032 301	POLYESTER CAPACITOR(0.027uF/50V,J)			*
C111,112	00D 958 0021 209	POLYESTER CAPACITOR(0.0082uF/50V,J)			
C113,114	00D 958 7031 904	ELEC. CAPACITOR(100uF/25V,M)			*
C115,116	00D 958 7032 408	ELEC. CAPACITOR(22uF/16V,M)			*
C117	00D 958 7029 107	CERAMIC CAPACITOR(0.1uF/50V,Z)			*
C201,202	00D 958 7031 603	CHIP CAPACITOR(390pF/50V,J)			*
C203,204	00D 958 7032 408	ELEC. CAPACITOR(22uF/16V,M)			*
C205,206	00D 958 7030 808	CHIP CAPACITOR(100pF/50V,J)			*
C207,208	00D 958 7033 601	ELEC.CAPACITOR(100uF/16V,M)			*
C209,210	00D 958 7032 301	POLYESTER CAPACITOR(0.027uF/50V,J)			*
C211,212	00D 958 0021 209	POLYESTER CAPACITOR(0.0082uF/50V,J)			
C213,214	00D 958 7031 904	ELEC. CAPACITOR(100uF/25V,M)			*
C215,216	00D 958 7032 408	ELEC. CAPACITOR(22uF/16V,M)			*
C217	00D 958 7030 905	CHIP CAPACITOR(0.1uF/ 50V,Z)			*

Ref. No.	Part No.	Part Name	Remarks	Q'ty	New
C851-854	00D 958 7030 905	CHIP CAPACITOR(0.1uF/ 50V,Z)			*
C855-860	00D 958 7033 504	CHIP CAPACITOR(470pF/50V,K)			*
C901,902	00D 958 7031 603	CHIP CAPACITOR(390pF/50V,J)			*
C903,904	00D 958 7034 309	CHIP CAPACITOR(82pF/50V)			*
C905	00D 958 7029 107	CERAMIC CAPACITOR(0.1uF/50V,Z)			*
C907,908	00D 958 7032 408	ELEC. CAPACITOR(22uF/16V,M)			*
C909-912	00D 958 7029 709	ELEC. CAPACTIOR(10uF/25V,M)			*
C913-916	00D 958 7033 504	CHIP CAPACITOR(470pF/50V,K)			*
OTHER PARTS GROUP					
CN01A	00D 958 7015 700	15P SOCKET			*
CN02A	00D 958 7015 807	15P SOCKET			*
CN04,05	00D 958 7017 504	4P SOCKET(B4B-XH-A)			*
CN06	00D 958 7037 801	RJ45 JACK			*
CN07	00D 958 7017 708	4P SOCKET(B4B-XH-A)			*
JK101	00D 958 7037 704	4P RCA JACK			*
JK201	00D 958 7037 704	4P RCA JACK			*
JK851,852	00D 958 7037 306	HEADPHONE JACK(3.5)			*
JK901	00D 958 7037 403	6P RCA JACK			*
L01-03	00D 958 0016 900	BEAD CORE(86-019-A)			
SW101	00D 958 7015 409	SLIDE SW(SSSF122NA1-HF,6PIN)			*
SW201	00D 958 7015 409	SLIDE SW(SSSF122NA1-HF,6PIN)			*
W101	00D 958 7017 106	6P SOCKET((B6B-PH-K-S)			*
W201	00D 958 7017 106	6P SOCKET((B6B-PH-K-S)			*
	00D 958 7014 303	FIXED RACK(0.5t)			*
	00D 958 7039 605	CUSHION(PORON,10*8*5t)			*

JACK P.W.B. UNIT ASS'Y

Ref. No.	Part No.	Part Name	Remarks	Q'ty	New
SEMICONDUCTORS GROUP					
IC301	00D 958 7035 803	IC(NJM-2068M)			*
IC951	00D 958 7036 006	IC(BA15218F)			*
IC952	00D 958 7035 900	IC(NJM-2060V)			*
Q301	00D 958 7034 707	TRANSISTOR(2SC2878-B)			*
Q951,952	00D 958 0040 507	TRANSISTOR(2SC1740R)			
Q953-960	00D 958 7034 707	TRANSISTOR(2SC2878-B)			*
CAPACITORS GROUP					
C301,302	00D 958 7032 408	ELEC. CAPACITOR(22uF/16V,M)			*
C303	00D 958 7030 808	CHIP CAPACITOR(100pF/50V,J)			*
C304	00D 958 7030 303	CHIP CAPACITOR(22pF/50V,J)			*
C305	00D 958 7029 602	ELEC. CAPACITOR(4.7uF/50V,M)			*
C306	00D 958 7032 408	ELEC. CAPACITOR(22uF/16V,M)			*
C307	00D 958 7031 603	CHIP CAPACITOR(390pF/50V,J)			*
C308	00D 958 7033 708	CHIP CAPACITOR(68pF/50V,J)			*
C309	00D 958 7029 107	CERAMIC CAPACITOR(0.1uF/50V,Z)			*
C321,322	00D 958 7029 204	CERAMIC CAPACITOR(470pF/50V,K)			*
C323,324	00D 958 0021 306	CERAMIC CAPACITOR((100pF/50V,J)			
C953,954	00D 958 7032 903	CERAMIC CAPACITOR(390pF/50V,J)			*
C955,956	00D 958 7029 903	CERAMIC CAPACITOR(68pF/50V,J)			*
C957,958	00D 958 7029 709	ELEC. CAPACTIOR(10uF/25V,M)			*
C959	00D 958 7029 107	CERAMIC CAPACITOR(0.1uF/50V,Z)			*
C963,964	00D 958 7032 408	ELEC. CAPACITOR(22uF/16V,M)			*
C967-970	00D 958 7033 300	ELEC. CAPACITOR(47uF/16V,M)			*
C971,972	00D 958 7030 206	CHIP CAPACITOR(33pF/50V,J)			*
C973,974	00D 958 7029 107	CERAMIC CAPACITOR(0.1uF/50V,Z)			*
C975,976	00D 958 7029 204	CERAMIC CAPACITOR(470pF/50V,K)			*
C977,978	00D 958 0021 306	CERAMIC CAPACITOR((100pF/50V,J)			
C979-982	00D 958 7029 204	CERAMIC CAPACITOR(470pF/50V,K)			*
C983	00D 958 7029 301	CERAMIC CAPACITOR(1500pF/50V,K)			*
OTHER PARTS GROUP					
CN03	00D 958 7017 407	10P SOCKET(B10B-XH-A)			*
JK301	00D 958 7037 209	HEADPHONE JACK(6.4)			*
JK302	00D 958 7037 607	MIC JACK			*
JK951-954	00D 958 7037 607	MIC JACK			*
JK955,956	00D 958 7037 209	HEADPHONE JACK(6.4)			*
W04	00D 958 7017 805	4P CONNECTOR WIRE(L=60mm)			*

CPU P.W.B. UNIT ASS'Y

Ref. No.	Part No.	Part Name	Remarks	Q'ty	New
SEMICONDUCTORS GROUP					
IC110	00D 958 7036 006	IC(BA15218F)			*
IC111,112	00D 958 7035 007	IC(THAT2180LC)			*
IC113	00D 958 7034 901	IC(ADG212AKR)			*
IC210	00D 958 7036 006	IC(BA15218F)			*
IC211,212	00D 958 7035 007	IC(THAT2180LC)			*
IC213	00D 958 7034 901	IC(ADG212AKR)			*
IC401	00D 958 7036 006	IC(BA15218F)			*
IC451,452	00D 958 7036 006	IC(BA15218F)			*
IC501-503	00D 958 7036 006	IC(BA15218F)			*
IC504	00D 958 7036 006	IC(BA15218F)			*
IC801	00D 958 7035 405	IC(MAX003)			*
IC802	00D 958 7014 400	CPU IC ASS'Y	IC(W39F010P-70B)		*
IC803	00D 958 7035 609	IC(BD4745G/BD4745G-TR)			*
Q101	00D 958 0040 701	TRANSISTOR(DTA124ES)			
Q201	00D 958 0040 701	TRANSISTOR(DTA124ES)			
RESISTORS GROUP					
RB801	00D 958 7022 405	FILM RESISTOR NETWORKS(10K OHM,J,8R9P)			*
RB802	00D 958 0014 601	FILM RESISTOR NETWORKS(10K OHM,J,6R7P)			
RB803	00D 958 7026 702	FILM RESISTOR NETWORKS(10K OHM,J,4R5P)			*
RB804	00D 958 7022 007	FILM RESISTOR NETWORKS(10K OHM,J,3R4P)			*
CAPACITORS GROUP					
C181,182	00D 958 7029 709	ELEC. CAPACTIOR(10uF/25V,M)			*
C183,184	00D 958 7029 107	CERAMIC CAPACITOR(0.1uF/50V,Z)			*
C185,186	00D 958 7030 303	CHIP CAPACITOR(22pF/50V,J)			*
C187	00D 958 7029 107	CERAMIC CAPACITOR(0.1uF/50V,Z)			*
C281,282	00D 958 7029 709	ELEC. CAPACTIOR(10uF/25V,M)			*
C283,284	00D 958 7029 107	CERAMIC CAPACITOR(0.1uF/50V,Z)			*
C285,286	00D 958 7030 303	CHIP CAPACITOR(22pF/50V,J)			*
C287	00D 958 7029 107	CERAMIC CAPACITOR(0.1uF/50V,Z)			*
C401	00D 958 7029 107	CERAMIC CAPACITOR(0.1uF/50V,Z)			*
C403,404	00D 958 7034 309	CHIP CAPACITOR(82pF/50V)			*
C451,452	00D 958 7031 807	CERAMIC CAPACITOR(0.22uF/50V,Z)			*
C453,454	00D 958 7031 409	CHIP CAPACITOR(0.33uF/50V,Z)			*
C455,456	00D 958 7029 107	CERAMIC CAPACITOR(0.1uF/50V,Z)			*
C457	00D 958 7031 302	CHIP CAPACITOR(0.033uF/50V,K)			*
C458	00D 958 7031 409	CHIP CAPACITOR(0.33uF/50V,Z)			*
C501,502	00D 958 7029 107	CERAMIC CAPACITOR(0.1uF/50V,Z)			*
C503,504	00D 958 7030 400	CHIP CAPACITOR (27pF/50V,J)			*
C505-508	00D 958 7029 408	ELEC. CAPACITOR(2.2uF/50V,M)			*
C509,510	00D 958 7029 107	CERAMIC CAPACITOR(0.1uF/50V,Z)			*
C511,512	00D 958 7033 708	CHIP CAPACITOR(68pF/50V,J)			*
C801	00D 958 7029 505	ELEC. CAPACITOR(100uF/10V,M)			*
C802	00D 958 7029 107	CERAMIC CAPACITOR(0.1uF/50V,Z)			*
C804,805	00D 958 7030 905	CHIP CAPACITOR(0.1uF/ 50V,Z)			*
C806,807	00D 958 7031 108	CHIP CAPACITOR(20pF/ 50V,J)			*
C808	00D 958 7030 905	CHIP CAPACITOR(0.1uF/ 50V,Z)			*
C809,810	00D 958 7029 107	CERAMIC CAPACITOR(0.1uF/50V,Z)			*

Ref. No.	Part No.	Part Name	Remarks	Q'ty	New
C811	00D 958 7029 505	ELEC. CAPACITOR(100uF/10V,M)			*
C812	00D 958 7029 408	ELEC. CAPACITOR(2.2uF/50V,M)			*
C813-818	00D 958 7029 000	CERAMIC CAPACITOR(0.047uF/50V,Z)			*
OTHER PARTS GROUP					
CN801	00D 958 7016 000	4P CONNECTOR WIRE			*
CN802	00D 958 0044 600	3P SOCKET			*
CN803	00D 958 7016 000	4P CONNECTOR WIRE			*
CN804	00D 958 7017 203	10P SOCKET			*
CN805	00D 958 7017 902	5P SOCKET			*
FFC01A	00D 958 7016 806	11P FFC CONNECTOR			*
FFC02A	00D 958 7017 300	10P FFC CONNECTOR(SMD)			*
FFC03A	00D 958 7016 903	15P FFC CONNECTOR			*
L801,802	00D 958 0016 900	BEAD CORE(86-019-A)			*
W07	00D 958 7016 107	4P CONNECTOR WIRE			*
X801	00D 958 7037 908	CITIZEN BRAND(CSA-309,16MHz)			*
	00D 958 7015 603	SOCKET(PLCC32TS)	for IC802		*

TRANS P.W.B. UNIT ASS'Y

Ref. No.	Part No.	Part Name	Remarks	Q'ty	New
OTHER PARTS GROUP					
SW01	00D 958 7015 001	LEVEL SW(LBC22B-095)			*
CN01	00D 958 7017 106	6P SOCKET			*

CH VR P.W.B. UNIT ASS'Y

Ref. No.	Part No.	Part Name	Remarks	Q'ty	New
RESISTORS GROUP					
VR01	00D 958 7037 005	SLIDE VR(RA45D2-211-15D1-R0B50K)			*
OTHER PARTS GROUP					
W801A	00D 958 7017 601	4P SOCKE			*
	00D 958 7014 604	FIXING PLATE			*
	00D 958 7039 207	SCREW(ISOF,3*4,ZS)			*

FADER START P.W.B. UNIT ASS'Y

Ref. No.	Part No.	Part Name	Remarks	Q'ty	New
OTHER PARTS GROUP					
SW801-804	00D 958 7015 409	SLIDE SW(SSSF122NA1-HF,6PIN)			*
W805	00D 958 7016 204	5P CONNECTOR WIRE			*

REVERSE P.W.B. UNIT ASS'Y

Ref. No.	Part No.	Part Name	Remarks	Q'ty	New
SEMICONDUCTORS GROUP					
D801-803	00D 958 0041 700	LED (RED)			*
RESISTORS GROUP					
VR801-803	00D 958 7036 307	ROTARY VR(10KB,RD09L114001K)			*
OTHER PARTS GROUP					
SW805-807	00D 958 7014 701	PUSH SW(PSA-42E06L-O-250)			*
W804	00D 958 7016 709	10P CONNECTOR WIRE			*
	00D 958 7038 402	LED HOLDER	for D801-803		*
	00D 958 0045 803	BRACKET(L TYPE)			*
	00D 958 7038 907	SCREW(M3*P0.5*5L)			*

PHONE P.W.B. UNIT ASS'Y

Ref. No.	Part No.	Part Name	Remarks	Q'ty	New
SEMICONDUCTORS GROUP					
C527,528	00D 958 7029 301	CERAMIC CAPACITOR(1500pF/50V,K,)			*
OTHER PARTS GROUP					
CN501	00D 958 0021 801	3P SOCKET			
JK501	00D 958 7037 209	HEADPHONE JACK(6.4)			*

EXPLODED VIEW

Parts List

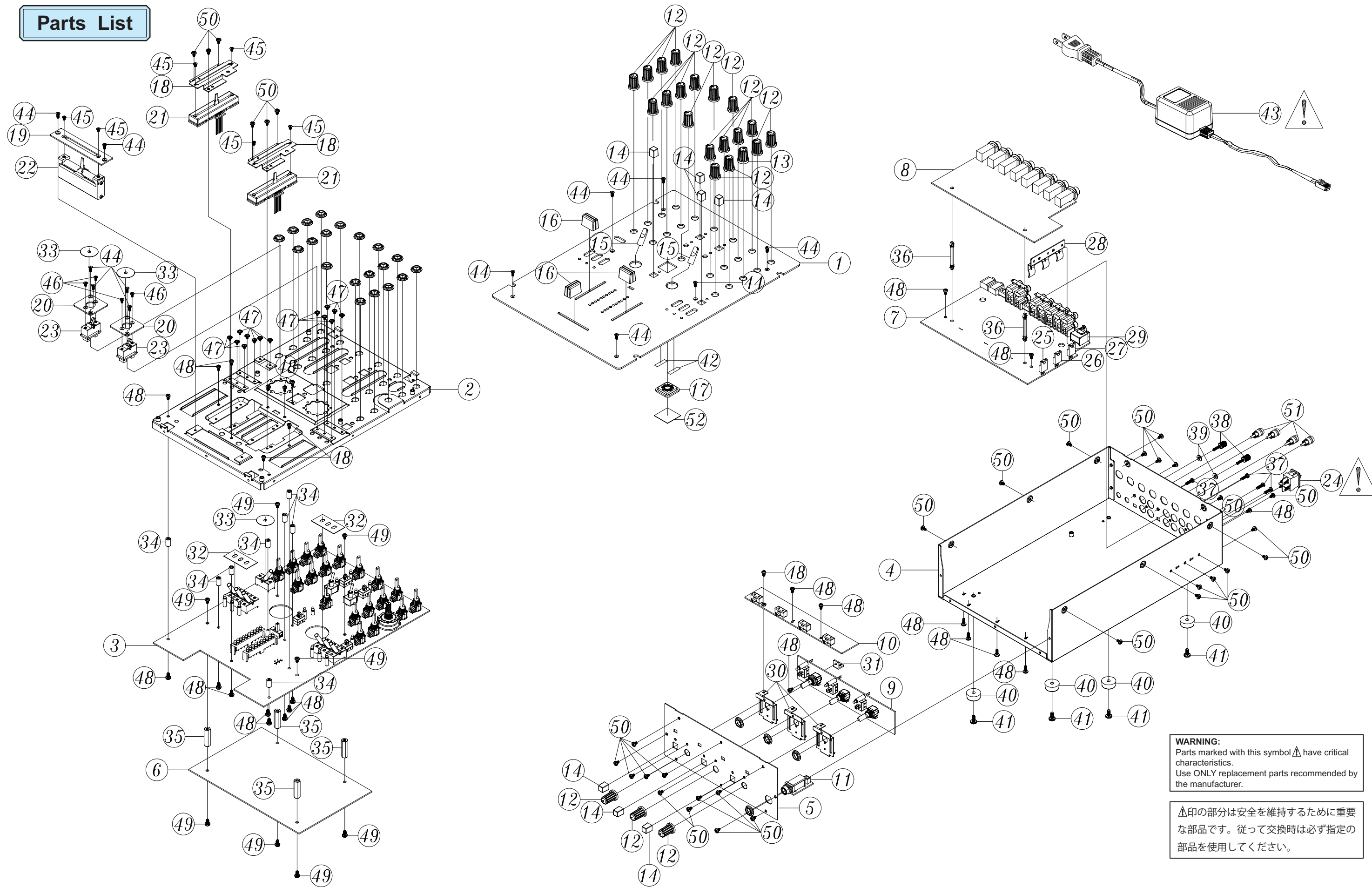

WARNING:
 Parts marked with this symbol  have critical characteristics.
 Use ONLY replacement parts recommended by the manufacturer.

印の部分は安全を維持するために重要な部品です。従って交換時は必ず指定の部品を使用してください。

PARTS LIST OF EXPLODED VIEW

*本表に記載されている部品は、補修用部品のため製品に使用している部品とは一部、形状、寸法などが異なる場合があります。

Note: The symbols in the column "Remarks" indicate the following destinations.

E3: U.S.A. & Canada model

E2: Europe model

EK: U.K. model

E2A: Asia model

E1C: China model

EUT: Taiwan R.O.C. model

E1K: Korea model

JP: Japan model

Ref. No.	Part No.	Part Name	Remarks	Q'ty	New
1	00D 958 7013 809	FRONT PANEL		1	*
2	00D 958 7040 102	FRONT BOARD ASS'Y		1	*
3	00D 958 7041 101	MIXER PCB ASS'Y		1	*
4	00D 958 7040 209	BOTTOM BASE ASS'Y		1	*
5	00D 958 7013 906	FRONT COVER		1	*
6	00D 958 7042 304	CPU PCB ASS'Y		1	*
7	00D 958 7041 509	OUTPUT PCB ASS'Y		1	*
8	00D 958 7041 907	JACK PCB ASS'Y		1	*
9	00D 958 7042 809	REVERSE PCB ASS'Y		1	*
10	00D 958 7042 702	FADER START PCB ASS'Y		1	*
11	00D 958 7043 206	PHONE PCB ASS'Y		1	*
12	00D 958 7012 907	ROTARY KNOB(ABS,BLACK)		22	*
13	00D 958 7013 003	ROTARY KNOB(36)		1	*
14	00D 958 7013 100	SQUARE KNOB		7	*
15	00D 958 7013 508	POKE KNOB(BLACK)		2	*
16	00D 958 7013 401	PUSH KNOB		3	*
17	00D 958 7013 207	MARK WINDOW		1	*
18	00D 958 7014 604	FIXING PLATE		2	*
19	00D 958 7014 109	FIXED PLATE FOR SLIDE VR		1	*
20	00D 958 7014 507	APART BOARD		2	*
21	00D 958 7043 109	CH VR PCB ASS'Y		2	*
22	00D 958 7036 909	SLIDE VR(50KB,D462627/H)		1	*
23	00D 958 7043 002	TRANS PCB ASS'Y		2	*
24	00D 958 7015 302	POWER SW		1	*
25	00D 958 0040 303	IC 7805		1	*
26	00D 941 0021 405	IC(NJM7915FA)		1	*
27	00D 958 7035 502	IC(NJM7815FA 3PIN)		1	*
28	00D 958 7014 206	FIXED PLATE FOR IC		1	*
29	00D 958 7014 303	FIXED RACK		1	*
30	00D 958 7014 002	FIXED PLATE FOR ROTARY VR		3	*
31	00D 958 0045 803	BRACKET(L TYPE)		1	*
32	00D 958 7039 702	CUSHION(26*10mm,t=0.5mm)		2	*
33	00D 958 7039 809	CUSHION(28*4.8*0.5t)		3	*
34	00D 958 7013 702	SLEEVE(6*10.2L)		8	*
35	00D 958 7038 305	SPACER SUPPORT(H-20)		4	*
36	00D 958 7038 101	SPACER SUPPORT(KCA-30)		2	*
37	00D 958 0006 004	SCREW(3*10 ZK PTP)		4	*
38	00D 958 7013 605	GROUND PIN		2	*
39	00D 958 7039 508	WASHER(8*3.2*1t,NI)		2	*
40	00D 958 7039 401	RUBBER FOOT		4	*
41	00D 958 7043 303	SCREW(STB,4*8,ZB)		4	*
42	00D 958 7038 509	REVERSIBLE PASTE(3mm)		2	*
43	00D 958 7043 400	TRANSFORMER(AC120V)	for E3	1	*
43	00D 958 7043 507	TRANSFORMER(AC230V)	for E2	1	*
43	00D 958 7043 604	TRANSFORMER(AC100V)	for JP	1	*
44	00D 958 7038 800	SCREW(CTF,3*7)		12	*
45	00D 958 7039 207	SCREW(ISO F,3*4,ZS)		6	*
46	00D 958 7039 003	SCREW(2.6*5)		4	*
47	00D 958 0001 902	SCREW(2.6*4 P=0.45)		14	*
48	00D 958 7038 907	SCREW(M3*P0.5*5L)		26	*
49	00D 958 7039 304	PLASTIC SCREW(S-306-N66)		8	*
50	00D 958 7039 100	SCREW(BTB,3*5,ZB)		32	*
51	00D 958 7037 500	RCA ADAPTOR PLUG(A028)		4	*

PACKING VIEW

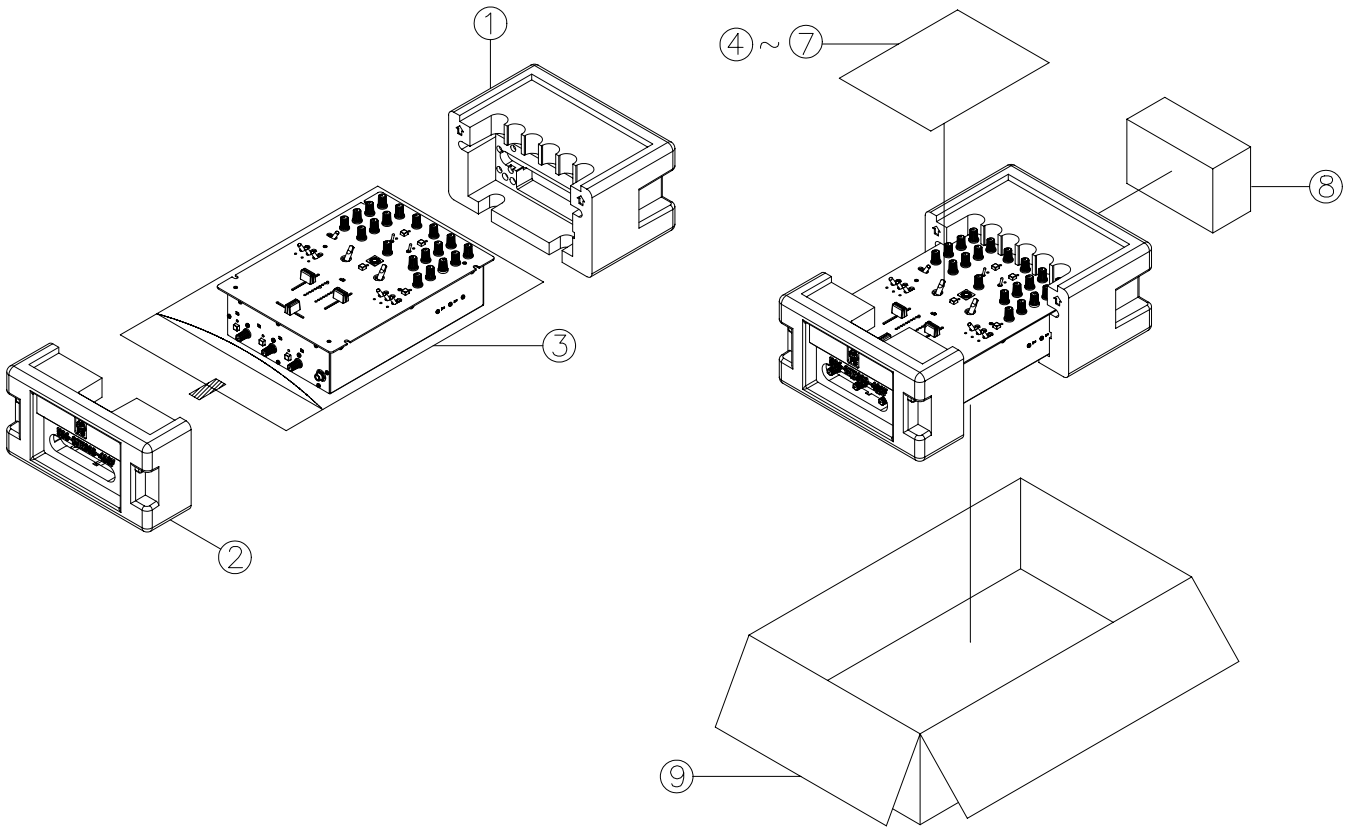

PARTS LIST OF PACKING & ACCESSORIES

*本表に記載されている部品は、補修用部品のため製品に使用している部品とは一部、形状、寸法などが異なる場合があります。

Note: The symbols in the column "Remarks" indicate the following destinations.

E3: U.S.A. & Canada model E2: Europe model EK: U.K. model E2A: Asia model
 E1C: China model EUT: Taiwan R.O.C. model E1K: Korea model JP: Japan model

	Ref. No.	Part No.	Part Name	Remarks	Q'ty	New
	1	00D 958 7044 302	POLYFOAM B		1	*
	2	00D 958 7044 409	POLYFOAM F		1	*
	3	00D 958 7045 000	SOFT BAG		1	*
	4	00D 958 0039 505	POLY COVER		1	
	5	00D 958 7044 001	INST. MANUAL	for E3,E2	1	*
	5	00D 958 7043 905	INST. MANUAL	for JP	1	*
	6	00D 515 0923 304	S.S.LIST	for E3,E2	1	
	6	00D 515 0918 209	S.S.LIST	for JP	1	
	7	00D 515 0966 109	WARRANTEE	for E3	1	
⚠	8	00D 958 7043 400	TRANSFORMER(AC120V)	for E3	1	*
⚠	8	00D 958 7043 507	TRANSFORMER(AC230V)	for E2	1	*
⚠	8	00D 958 7043 604	TRANSFORMER(AC100V)	for JP	1	*
	9	00D 958 7044 807	GIFT BOX(480*294*163mm)	for E3,E2	1	*
	9	00D 958 7044 700	GIFT BOX(480*294*163mm)	for JP	1	*
	★ 10	00D 515 0919 004	GUARANTEE CARD(S)	for JP	1	
	★ 11	00D 958 7018 309	POS LABEL	for JP	1	*

NOTE FOR SCHEMATIC DIAGRAM

WARNING:

Parts marked with this symbol \triangle have critical characteristics. Use ONLY replacement parts recommended by the manufacturer.

CAUTION:

Before returning the unit to the customer, make sure you make either (1) a leakage current check or (2) a line to chassis resistance check. If the leakage current exceeds 0.5 milliamps, or if the resistance from chassis to either side of the power cord is less than 460 kohms, the unit is defective.

WARNING:

DO NOT return the unit to the customer until the problem is located and corrected.

NOTICE:

ALL RESISTANCE VALUES IN OHM. k=1,000 OHM
M=1,000,000 OHM
ALL CAPACITANCE VALUES IN MICRO FARAD.
P=MICRO-MICRO FARAD
EACH VOLTAGE AND CURRENT ARE MEASURED AT
NO SIGNAL INPUT CONDITION.
CIRCUIT AND PARTS ARE SUBJECT TO CHANGE
WITHOUT PRIOR NOTICE.

配線図について

\triangle 印の部品は安全を維持するために重要な部品です。従って交換時は必ず指定の部品を使用してください。

注)

- (1) 指定なき抵抗値は Ω 、k は k Ω 、M は M Ω を示す。
- (2) 指定なきコンデンサーの値は μF 、p は pF を示す。
- (3) 各部の電圧は無信号の値を示す。
- (4) この配線図は基本配線図です。改良等のため変更することがありますのでご了承ください。

SCHEMATIC DIAGRAMS (1/3)

1 2 3 4 5 6 7 8 9 10 11

A
B
C
D
E
F
G
H

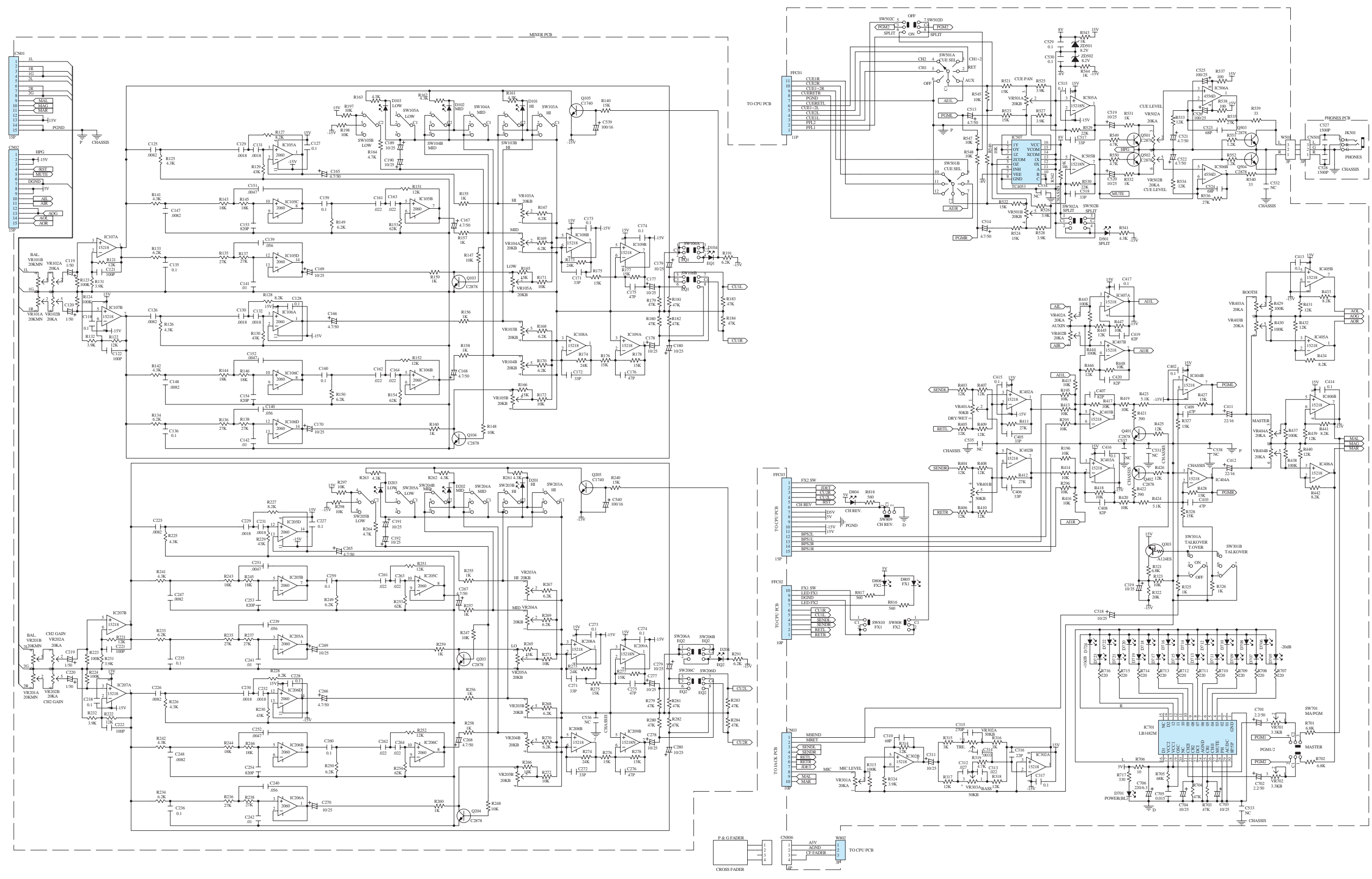

SCHEMATIC DIAGRAMS (1/3)
MIXER UNIT
PHONE UNIT

SCHEMATIC DIAGRAMS (2/3)

1 2 3 4 5 6 7 8 9 10 11

A
B
C
D
E
F
G
H

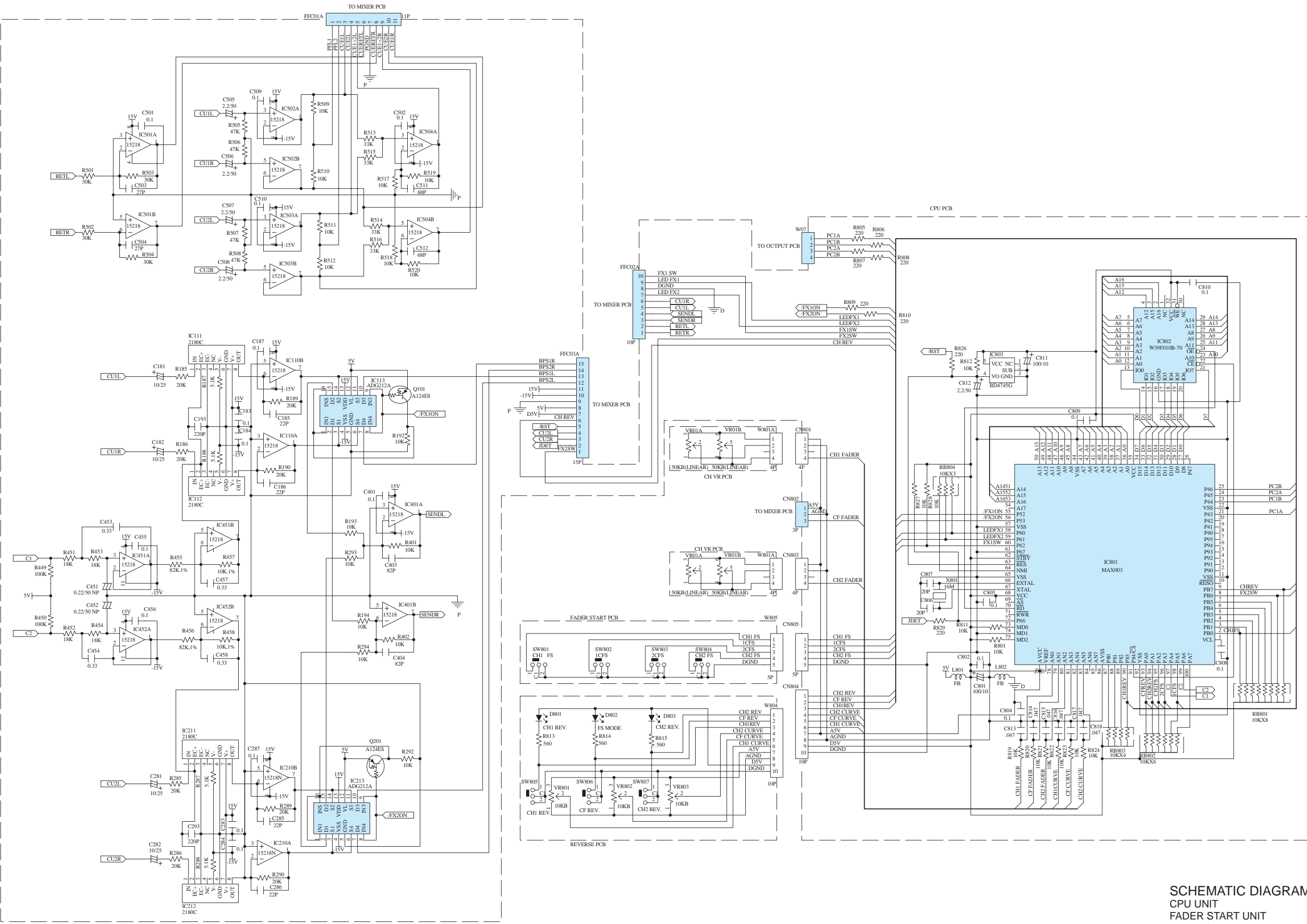

SCHEMATIC DIAGRAMS (2/3)
CPU UNIT
FADER START UNIT
REVERSE UNIT
CH VR UNIT

SCHEMATIC DIAGRAMS (3/3)

1 2 3 4 5 6 7 8 9 10 11

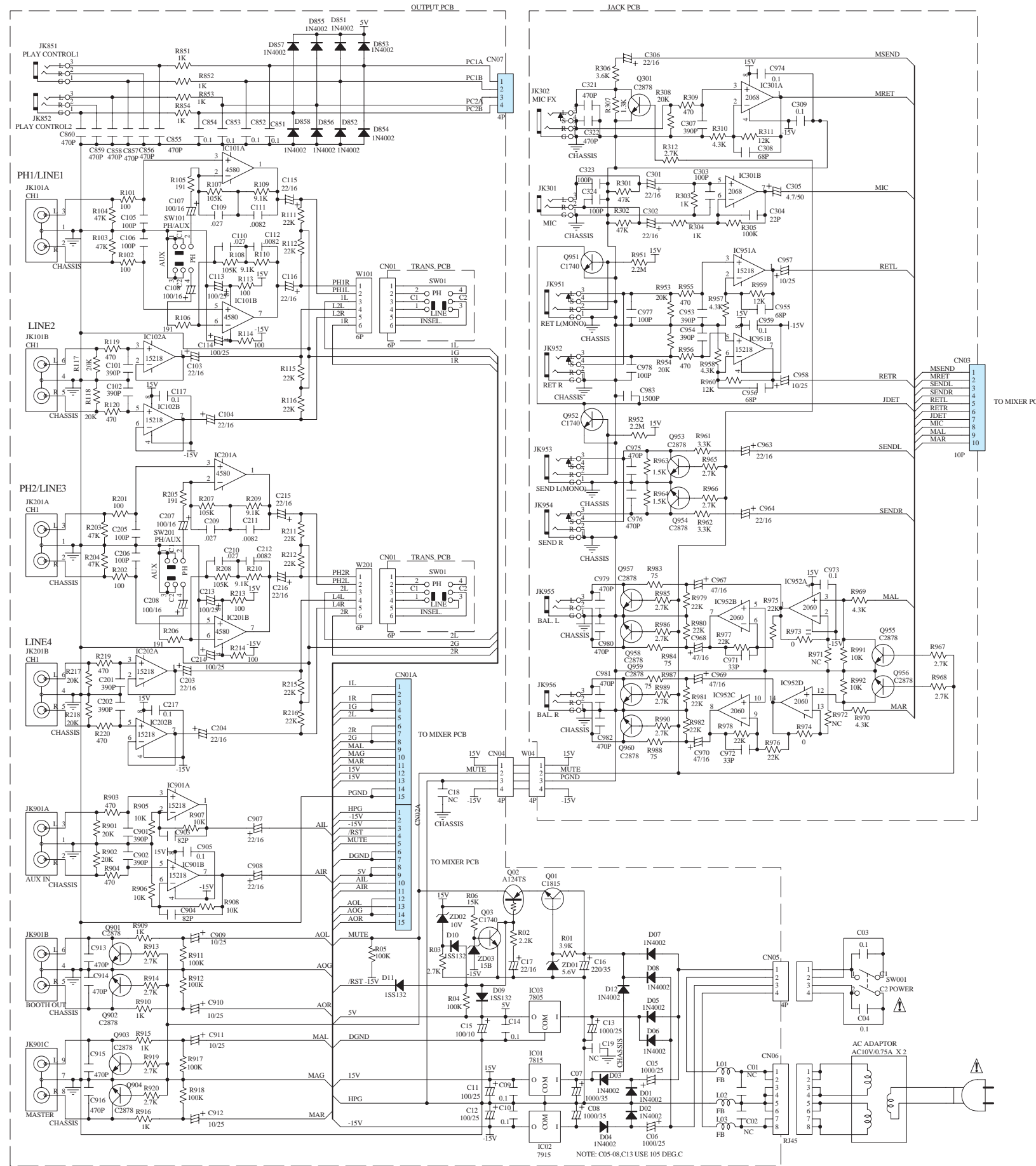

SCHEMATIC DIAGRAMS (3/3)
OUTPUT UNIT
JACK UNIT
TRANS UNIT