

# DENON

Hi Fi Component

## SERVICE MANUAL

### FULLY AUTOMATIC DIRECT DRIVE TURNTABLE SYSTEM

### MODEL DP-11F SERIES

U.S. and Canadian models do not include cartridge.



## NIPPON COLUMBIA CO., LTD.

# TABLE OF CONTENTS

FEATURES .....	1
SPECIFICATIONS .....	2
BLOCK DIAGRAM .....	3
PART NAMES AND FUNCTION .....	4
EXPLANATION OF THE MICROPROCESSOR .....	5 ~ 8
ADJUSTMENT METHOD .....	9 ~10
PARTS LIST OF EXPLODED VIEW .....	11
EXPLODED VIEW OF MAIN PARTS .....	12
SCHEMATIC DIAGRAM .....	13
PRINTED CIRCUIT BOARD .....	14
CONNECTIONS OF P.C. BOARD .....	15
PARTS LIST OF P.C. BOARD .....	16

**WARNING:**

**1. Component parts**

Parts marked with and/or shading in this service manual have special characteristics important to safety. Be sure to use the specified parts for replacement.

**2. Leakage current**

Before returning the appliance to customer, test the leakage current when the power plug is connected. Use a calibrated (with an error of not more than 5%) leakage current tester and measure the leakage current from any exposed metal to the earth ground. Reverse the power plug polarity and test the above again.

Any current measured MUST NOT EXCEED 0.5 miliamps. Corrective measure must be taken if it exceeds the limit.

## FEATURES

**Silent, fully automatic operations with the use of a microprocessor controlled contactless servo tonearm.**

An innovative microprocessor controlled, contactless servo tonearm ensures safe, easy to use automatic operations with little loss in sound quality.

**Low mass straight arm**

This arm is fully capable of maximizing the performance of high compliance cartridges with outstanding tracing ability. Even with the newest, high grade records, its tracing ability is outstanding.

**DENON Quartz**

The turntable speed is controlled by the "DENON Quartz" which is the combination of the "High Precision Magnetic Pulse Detection Method", the most sophisticated method of FG detection, and the "Quartz Lock".

## SPECIFICATIONS

### Phonomotor section

<b>Drive system:</b>	Servo controlled direct drive
<b>Turntable speeds:</b>	33-1/3, 45 rpm
<b>Wow &amp; flutter:</b>	Below 0.02% wrms (servo system) Below 0.03% wrms (JIS)
<b>S/N ratio:</b>	Over 75 dB (DIN-B)
<b>Rise time:</b>	Normal speed within 2 seconds (at 33-1/3 rpm)
<b>Platter:</b>	Aluminum die-cast; 300 mm diameter
<b>Motor:</b>	Linear drive motor
<b>Speed control system:</b>	Speed servo by frequency detection, phase servo control
<b>Speed deviation:</b>	Below 0.002%
<b>Load characteristics:</b>	0% (80 g stylus force; outermost groove)

### General

<b>Power supply:</b>	50~60 Hz, Voltage is shown on rating label
<b>Power consumption:</b>	7 W
<b>Dimensions:</b>	100 x 365 x 335 mm (H x W x D)
<b>Weight:</b>	Approximately 5 kg

### Tonearm section

<b>Arm type:</b>	Dynamically balance, semi-integrated straight arm
<b>Effective length:</b>	220 mm
<b>Overhang:</b>	16 mm
<b>Tracking error:</b>	Within 3°
<b>Automatic mechanism:</b>	Electronically controlled, fully automatic
<b>Adjustable stylus force range:</b>	0~3.0 g (1 scale=0.1 g)
<b>Suitable cartridge weight range:</b>	Approximately 4.0~6.0 g (including screws, nuts)

### Cartridge section (Only for those models with attached cartridge)

<b>DL-60</b>	
<b>Type:</b>	Moving magnet (MM)
<b>Output voltage:</b>	2.5 mV
<b>Frequency response:</b>	20~30 kHz
<b>Stylus force:</b>	1.8±0.3 g

Above specifications and outward appearance may be altered in future for improvement.

U.S. and Canadian models do not include cartridge.

# BLOCK DIAGRAM

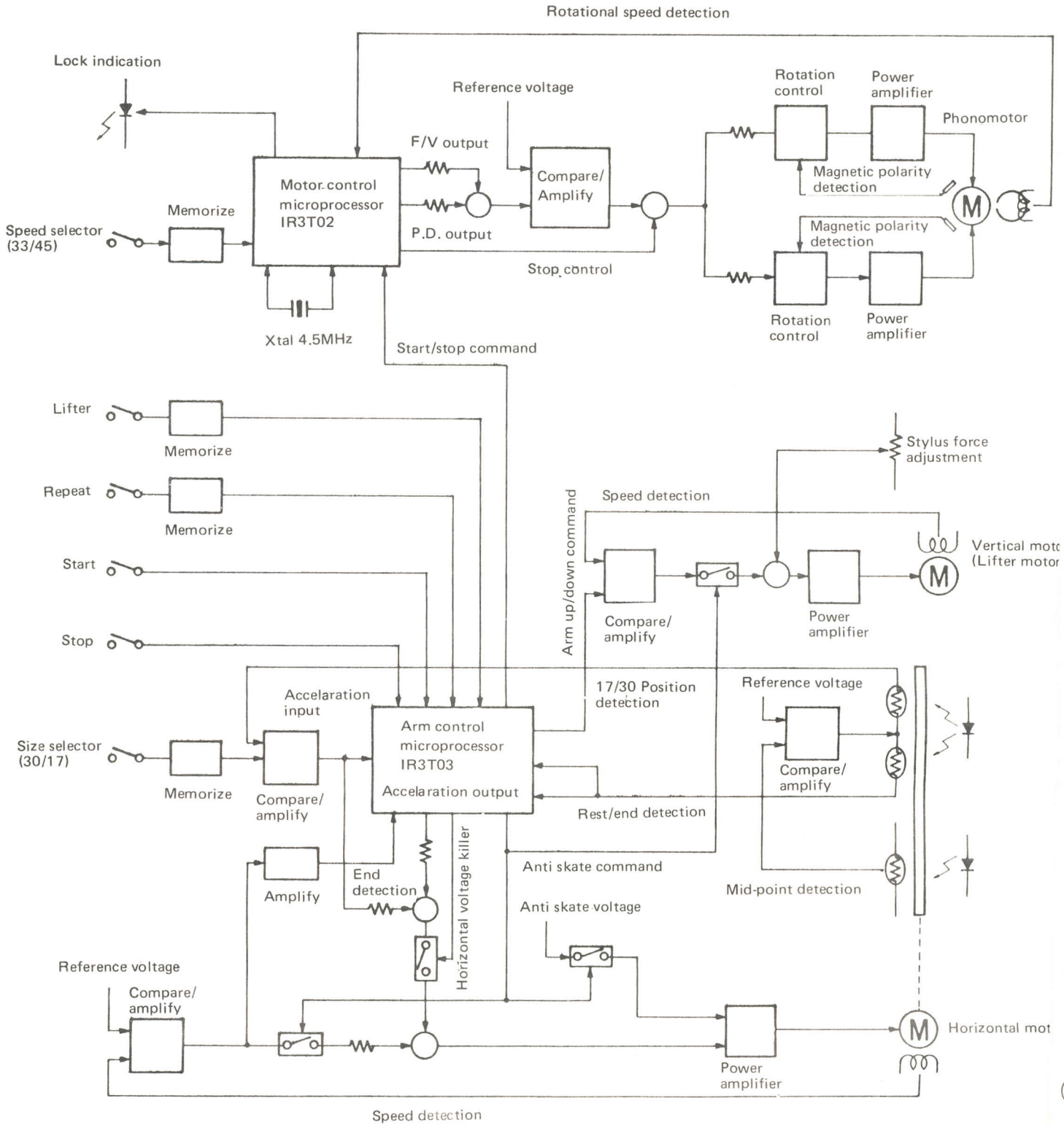

Note:  indicates an analog switch.

## PART NAMES AND FUNCTION

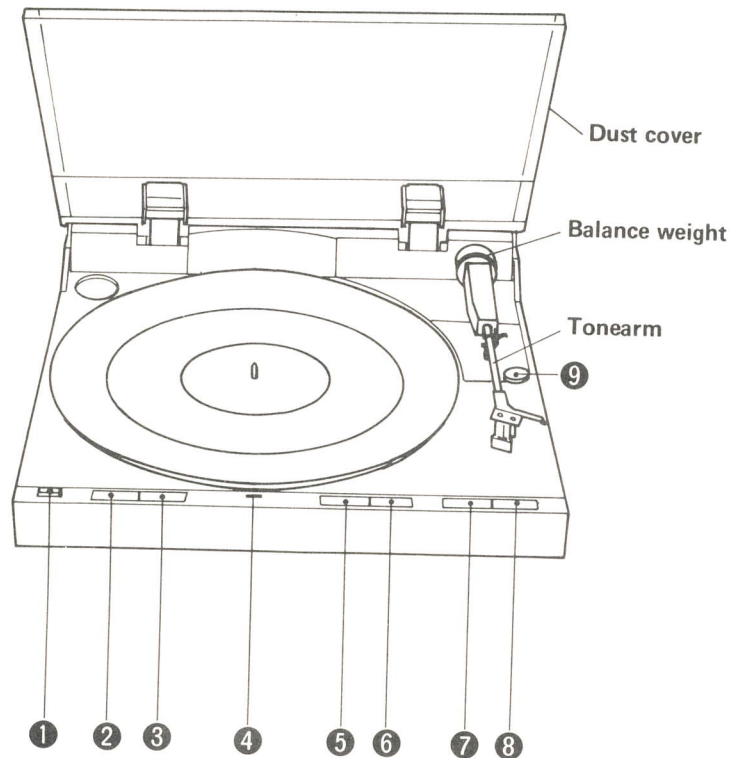

- 1 POWER (Power switch)**  
This switch turns the power supply on (☐) and off (■). When turning the power off, always return the tonearm to the arm rest and hold it in place with the clamp.
- 2 SIZE (Record size selector switch)**  
Set to the size of record to be played.  
30 cm records . . . . . "30" (lamp lit)  
17 cm records . . . . . "17" (lamp lit)
- 3 SPEED (Speed selector switch)**  
Set to the desired record speed.  
33-1/3 rpm records . . . . . "33" (lamp lit)  
45 rpm records . . . . . "45" (lamp lit)
- 4 LOCK (Lock indicator)**  
When the power is turned on, the lamp will light up. During play, the lamp will flicker until the proper turntable speed is reached. Once the proper speed is obtained, the lamp will, again, stay lit.
- 5 REPEAT (Repeat switch)**  
When playing the records repeatedly, switch it on (lamp lit).
- 6 ARM LIFTER (Arm lifter switch)**  
This switch is used to raise and lower the arm during play or when playing the records manually. The lamp is lit when arm is up.
- 7 START (Start switch)**  
Press this switch when starting the records automatically.
- 8 STOP (Stop switch)**  
Press this switch when stopping the record during play.
- 9 STYLUS FORCE (Stylus force adjustment knob)**  
This knob is used to adjust the stylus force.

# EXPLANATION OF THE MICROPROCESSOR

## ● Motor Control IC . . . IR3T02 (at standard revolution of 33 rpm)

The numbers on the left hand side indicates the terminal number.

### 2. 4.5MHz OSC

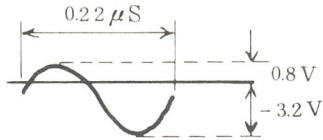

### 3. 4.5MHz OSC

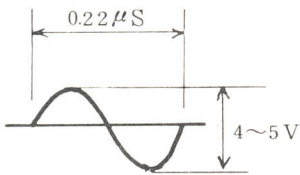

### 4. rpm selector

H: 45 rpm  
L: 33 rpm

### 5. power source input

$V_{cc}: 5V \pm 0.5V$

### 6. FG I bypass terminal

$E6 \doteq \frac{1}{2}V_{cc}$

### 7. FG I lowpass terminal

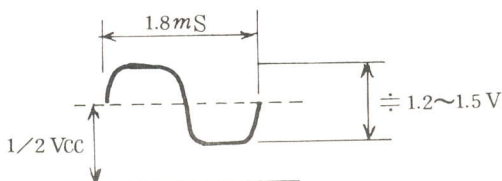

### 8. FG I output

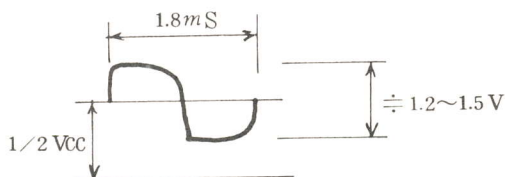

### 9. FG I inverse input

The gain set element is connected.  
 $E9 \doteq \frac{1}{2}V_{cc}$

### 10. FG I non-inverse input

$10mV_{pp} \sim 100mV_{pp}$   
 $E10 \doteq \frac{1}{2}V_{cc}$

### 14. ground terminal

### 15. F/V output

slower than normal revolution:  $2 \sim 4.5V$   
normal revolution:  $\doteq 2V$

faster than normal revolution:  $0 \sim 2V$

### 16. F/V hold terminal

same as terminal 15

### 17. F/V triangular wave

slower than normal revolution

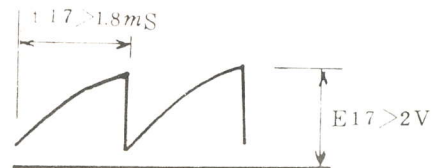

normal revolution



faster than normal revolution



18. timing pulse width-set terminal

$E18 \approx 0.6V$

19. PD triangular wave

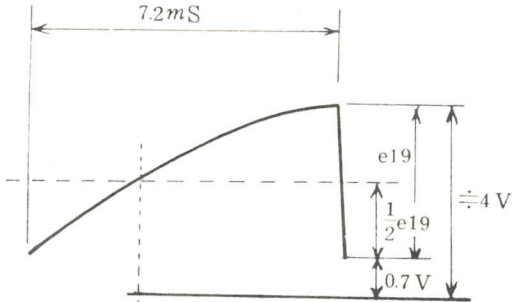

20. sample pulse monitor terminal

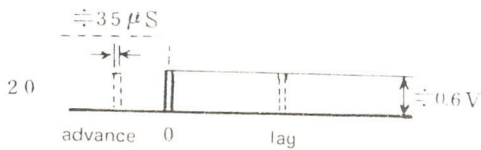

21 PD hold terminal

slow phase: 2 ~ 4V  
 normal phase:  $\approx 2V$   
 advanced phase: 1 ~ 3V

22. PD output

same as terminal 21

23. Lock detector time set terminal

during lock: 0.6V  
 lock disengaged: 0V

25. Revolution detector

during revolution:   $\approx 4V$

stop: 0V

26. START/STOP terminal

H  $\rightarrow$  START  
 L  $\rightarrow$  STOP

28. Lock indicator

during lock . . . . . (LED lit dimly)

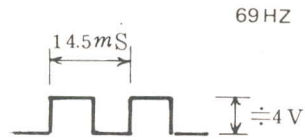

stop . . . . . (LED lit)

during transition . . (LED flashes)

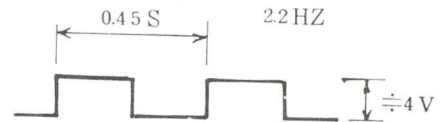

## ● Arm Control IC IR3T03

The numbers on the left side indicates the terminal number of the IR3T03.

### 1. Acceleration input

Except for the matching range of the lead-in detector ( $E7 \leq |\pm 0.6V|$ ), it will recognize the situation and control the acceleration during automatic tonearm operation.

### 2. Acceleration output

$E1 \leq |\pm 2.37V \pm 0.1V|$  . . . . open (will not control the acceleration within the matching range)

$E1 \geq |\pm 2.3V \pm 0.1V|$  . . . .  $E2 \doteq \pm 3.95V$

-3.95V: will accelerate toward the inside from rest.

+3.95V: will accelerate toward rest from the inside.

### 3. UP/DOWN selection of the arm lifter

When E9 is H, the control output for lifting the arm will be made at  $E3 \doteq -V_{cc}$ .

When E9 is L, the control output for lowering the arm will be made at  $E3 \doteq +V_{cc}$ .

### 4. Detection of the rest position

$E4 \leq -2.64V$  will be recognized as the arm being at rest.

### 5. Detection of the END position

When  $E5 \geq 2.64V$ , it will be recognized to be within the END detection range.

$E5 \geq 2.64V$  when the stylus tip nears the last sections of the sound groove.

### 6. End control

Whithin the END detection range of 5 (above), ( $E5 \geq 2.64V$ ), the arm will be returned by the END control when  $E6 \geq 0.23V$ .

$E5 \geq 0.23V$  when the stylus tip moves into the lead-out groove and the arm moves fast.

### 7. Matching input

$E7 \leq |\pm 0.6V|$  will be recognized as the match range for lead-in.

### 8. Drive output

Connect to GND.

### 9. UP control output

When the lifter is in the UP position during automatic arm operations or when the UP signal is sent by pressing the arm lifter button, pin 9 will be at H level.

$E9H \doteq 4V$

$E9L \doteq 0V$

### 10. DOWN time constant

To ensure that the arm is lowered completely before proceeding to the next movement, a resistor between pins 9 and 10 and a capacitor on pin 10 has a preset discharge time constant which is somewhat longer than the time required for the arm to be lowered. Thus, when pin 9 becomes L ( $E9L \doteq 0V$ ), and the fixed amount of time elapses, the arm will be recognized to be DOWN as soon as  $E10 < 2V$ .

### 11. ANT (Anti-skating) control

When  $E10 < 2V$ , then  $E11 \doteq -4V$  will be the control output needed for the anti-skating to be engaged.

When  $E10 \geq 2V$ , then  $E11 \doteq +4V$  will be the control output needed for the anti-skating to be disengaged.

### 12. Negative power source

Supplies  $-5V$ .

### 14. SUB (substratum)

To prevent any interference from the inner elements of the LSI, the substratum terminal is connected to the unregulated side of the negative power source, since it has the lowest electric potential.

### 15. GND

Standard zero electric potential is the GND.

### 17. Return control

When the stop command is given, or when the repeat is disengaged and the END is detected ( $E6 \geq 0.23V$ ), a control signal output ( $E17H > 4V$ ) is made to return the arm to rest.

$E17H > 4V$

$E17L$ : release

### 18. Horizontal drive control

When the arm is in resting position, or when the arm reaches the lead-in position during automatic play, and comes into the matching range ( $E7 \leq |\pm 0.6V|$ ), a control signal output ( $E18H \doteq 4V$ ) is made to stop the horizontal motion of the arm.

### 19. Initial set

This is the preparation time setting terminal when the power source is turned on. The resistor in the LSI and the outer capacitor will set the charge time constant and carry out the initial set.



## 20. LCTD (Located) time constant

The LSI and its outer circuits will set the LCTD time constant to improve the detection accuracy of the lead-in position and the arm rest position.

E20H  $\doteq$  1.2V . . . . . A few moments after the arm reaches the range of detection, in other words, after the set LCTD time constant elapses, it will become H level, where it is memorized immediately and then reset to the L level.

E20L  $\doteq$  0V . . . . . Before and after detection, it will become L level.

## 21. Turntable (T/T) Drive Control

E21L  $\doteq$  0V . . . . . the turntable stops

E21H release . . . . . the turntable rotates

(refer to the operational explanations for pin 22)

## 22. Turntable (T/T) Start Position

This terminal establishes the turntable start position. The turntable will start when the arm separates from the arm rest and pin 22 is released, under manual and auto modes.

## 23. Start

Will start automatically at the GND level.

## 24. Auto stop

Will stop automatically at the GND level.

## 25. Lifter

Will raise the lifter automatically at the GND level.

## 26. Repeat

Will engage the repeat automatically at the GND level.

## 27. UP SW

An UP time constant circuit is used so that when the lifter is in the UP condition, this terminal is released and becomes H level; and at other times, it becomes GND level.

With this unit, the arm will start to move approximately two seconds after the UP command.

## 28. Positive power supply

Supplies +5V.

## ADJUSTMENT METHOD

\* Prepare a two-channel oscilloscope for the measuring instrument.

### ● Adjusting the Phonomotor Section

\* Measure, using the wrapping terminal number 8 of the motor drive circuit board as the ground referent point when adjusting the motor OP amp. voltage offset and the motor torque.

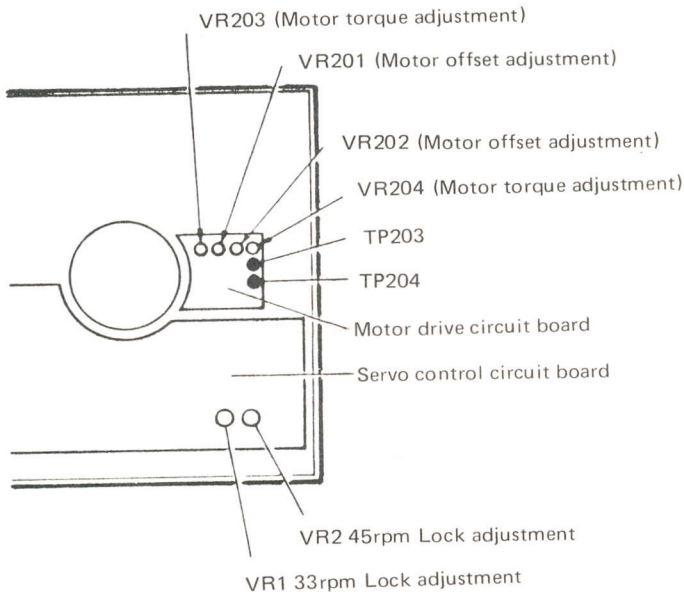

### 1. Adjusting the motor amp. offset voltage

- 1) Fix the tonearm to the arm rest and connect the oscilloscope to TP 203 and 204 .
- 2) Rotating the turntable by hand, adjust the center of amplitude at TP 203 to  $0 \pm 0.1V$  by turning VR 201 .
- 3) Following the preceding directions adjust to  $0 \pm 0.1V$  by turning VR 202 for TP 204 .

### 2. Adjusting the motor torque

- 1) Leave the oscilloscope connections as they were for the motor OP amp. voltage offset adjustments.
- 2) Take the turntable off the main body; move the tonearm close to the speed detection head and rotate the phonomotor at a fast speed.

**(Note)** Be very cautious as not to damage the cartridge during this procedure.

- 3) For T.P. 203 , rotate VR 203 and adjust to  $15VP-P \pm 0.5V$ .
- 4) For T.P. 204 , rotate VR 204 and adjust to  $15VP-P \pm 0.5V$ .



### 3. Adjusting the head gap

Adjust, so that the gap between the turntable magnetic coating surface and the detection head is 0.18 mm.

### 4. Lock adjustments for 45 rpm

From hereafter, the earth reference point of the measuring instrument should be connected to T.P. 6 of the servo control circuit board.

- 1) Connect the two-channel oscilloscope to T.P. 1 and T.P. 2 .
- 2) Set the speed selector to 45 rpm.
- 3) Take the arm off the arm rest and move it toward the turntable to rotate the phonomotor.
- 4) Adjust VR2 so that the pulse from T.P. 1 is positioned to  $\frac{1}{2}$  the triangular wave length from T.P. 2 .

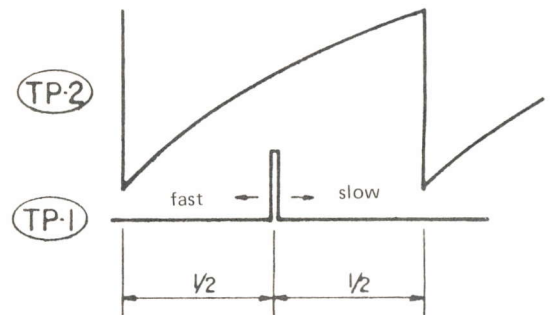

### 5. Lock adjustments for 33 rpm

- 1) Connect the oscilloscope in the same manner as the 45 rpm lock adjustments. Set the speed selector to 33 rpm.
- 2) Adjust VR1 in the same manner as the lock adjustments for 45 rpm.

## ● Adjusting the Arm Control Section

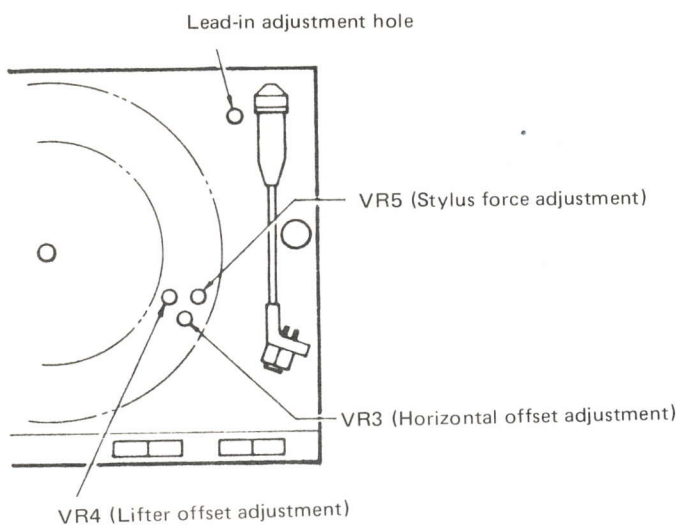

### 1. Adjusting the horizontal OP amp. offset voltage

- 1) Fix the tonearm to the armrest and connect the oscilloscope to T.P. 3.
- 2) Set the lifter switch to the UP condition.
- 3) Turn VR3 and adjust to  $0V \pm 0.01V$ .

### 2. Adjusting the lifter OP amp. offset voltage

- 1) Fix the tonearm to the armrest and connect the oscilloscope to T.P. 4.
- 2) Set the lifter switch to the DOWN condition.
- 3) Turn VR4 and adjust to  $-1V \pm 0.1V$ .

### 3. Adjusting the stylus force

- 1) Turn the power supply switch OFF.
- 2) Take the arm off the armrest. Rotate the balance weight so that the tonearm becomes parallel to the turntable surface when let go.
- 3) Return the arm to the armrest and turn the power supply switch ON.
- 4) Wait five seconds after the arm has lowered. Place the cartridge stylus tip onto a stylus force gauge and set the stylus force adjustment knob to 1.5 g.  
(Note) At this time, the stylus tip height should be adjusted so that it is about the same height as during play.
- 5) Turn VR5 and adjust, so that the stylus force gauge reads 1.5 g.

### 4. Adjusting the 30 cm lead-in position

- 1) Place a 30 cm record on the turntable and set the record size selector switch to "30".  
(Note) Keep the bottom cover closed.

- 2) Move the arm so that the stylus tip is at approximately the 30 cm lead-in position. Insert a small flat-headed screwdriver into the lead-in adjustment hole; move the arm back and forth and fit the screw driver into the groove of the cam inside gently.

- 3) After turning the screwdriver, pull it out. Press the start switch and adjust so that the stylus position stops at the 30 cm lead-in position.

(Note) The 30 cm lead-in adjustments cannot be performed unless the stylus tip position is approximately in the 30 cm lead-in position. In addition, if the screwdriver is left inserted, the arm will not move.

### 5. Adjusting the 17 cm lead-in position

Adjust as necessary, such as when parts of the sensor section have been replaced.

However, the following procedures should only be used when a discrepancy is found for the 17 cm lead-in position, after the 30 cm lead-in position has been adjusted.

- 1) Set the record size selector to 17 cm.
- 2) By continuously pressing the start switch, the arm will move over and stop. At this time, check how many millimeters, toward the inside or outside, the stylus tip deviates from the required 17 cm lead-in position.
- 3) Take off the bottom cover of the cabinet and check the adjustment scale position of the shutter. (One adjustment scale corresponds to a stylus tip movement of 5 mm.)
- 4) Untighten the screw holding the sub shutter and place a small screwdriver into the slot of the shutter. When the stylus position is toward the inside, compared to the required position, move the sub shutter toward the right of the scale; when the stylus position is toward the outside, move the sub shutter toward the left. When completed, tentatively tighten the screw holding the sub shutter.
- 5) After the adjustments are made, press the start switch and check whether or not the stylus stops at the 17 cm lead-in position.
- 6) If the stylus stops at the required position, then tighten the sub shutter screw.

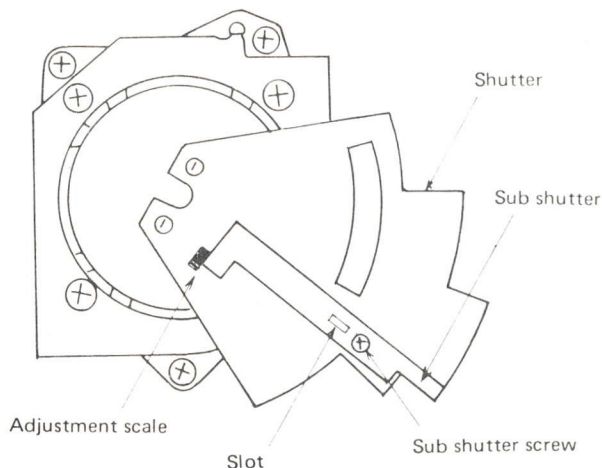

## PARTS LIST OF EXPLODED VIEW

Ref. No.	Part No.	Part Name	Remarks
1	4730306012	3x12 CBRTS (1)	
2	4751005004	4W	
3	1048066018	INSULATOR ASS'Y	
4	4730306038	3x12 CBRTS (1)	
5	1058083104	BOTTOM COVER ASS'Y	
6	4218217209	RECORDED TURN TABLE	
7	4218288005	RUBBER SHEET	
8	4628023009	BUSHING	
9	5298006002	45 ADAPTOR	
10	1468137103	DUST COVER ASS'Y	
11	4018059007	HINGE	
12		INCLUDED SCREW	
13	3158545113	ARM REST	
14	3138003109	CARTRIDGE GENE ASS'Y	E1,EF,EG,EA, EK,E1
15	3158705005	MAIN BODY ASS'Y	
16	2098251005	TERMINAL WIRE	
17	4618113000	SPRING PLATE	
18	2228468008	OUTPUT P.C.B	
19	4712303017	3x6 CFS	
20	4638225004	SPRING	
21	4711303018	3x6 CPS	
22	4751003006	3W	
23	4438545104	COLLAR	
24	4338172004	SUB SHUTTER	
25	4338177300	SHUTTER	
26	4761003009	3E RING	
27	3158451003	FRICTION WASHER	
28	3418025205	MAGNET ASS'Y	
29	2398013105	COIL ASS'Y	
30	4338181008	YOKE (A) GENE ASS'Y	
31	4744102037	3x3 SS	
32	4248019105	ADJUST CAM	
33	4418815003	ARM PLATE	
34	4698008009	INSULATOR MAT	
35	2228468008	CDS P.C.B	
36	4730304014	3x8 CBRTS (1)	
37	3939041001	LED	LN81RCP (HL)
38	2228468008	LED P.C.B	
39	4713808003	3x25 CBS	BsBW, MBNi II SUS305
40	4713806003	3x20 CPTS (1)	
41	2178062101	MOTOR ASS'Y	
42	4730309019	3x16 CBRTS (1)	
43	WA-0107-4	WASHER	
44	4620027003	RUBBER BUSH	
45	2339051003	POWER TRANS	E1 only
	2339058006	POWER TRANS	EU only
	2339050101	POWER TRANS	
46	4418846001	WASHER	
47	4418814208	HEAD SUPPORT	
48	3918423006	MAGNETIC HEAD	
49	4700009019	3x6 CPSW	
50	2228468008	VOLUME HOLDER P.C.B	
51	2118024002	V16V15KB502	
52	1128085003	VOLUME KNOB	
58	2033642103	OUTPUT CORD ASS'Y	
59	2062002031	AC CORD	E2, EF, EG
	2006019307	AS 3P AC CORD	EA
	2062024006	AC CORD WITH LABEL	EK
	2006031026	AC CORD WITH PLUG	E1
	2062019008	AC CORD WITH PLUG	EU

Ref. No.	Part No.	Part Name	Remarks
63	1038196406	CABINET	
	1038196422	CABINET	E1 only
64	2228468008	LED P.C.B	
65	3939140009	LED	GL-9PG24
66	2129130008	PUSH SWITCH	
67	3939153009	LED	PR-5524S-1
68	1138140103	STOP KNOB	
69	1138139101	START KNOB	
70	1138138102	LIFTER KNOB	
71	1138137103	REPEAT KNOB	
72	1138135105	SPEED KNOB	
73	1138136104	SIZE KNOB	
74	4730205016	2.6x10 CPTS (1)	
75	2129180003	PUSH SWITCH	
76	1138134009	KNOB	
77	KU-0419	SERVO CONTROL UNIT	
78	3168198000	CONNECTOR	
79	3158693104	BODY CASE	
80	3158695005	BALANCE WEIGHT	
81	3158709001	ADJUST SCREW	
82	2129185008	SLIDE SWITCH	E1 only
83	KU-0420	MOTOR DRIVE UNIT	

Remark symbols in the parts list refer to the following countries and areas.

- EA: Australia
- EK: United Kingdom
- EU: U.S.A. and Canada
- E1: Multiple voltage model
- E2: European continent
- EF: French
- EG: German

EXPLODED VIEW OF MAIN PARTS

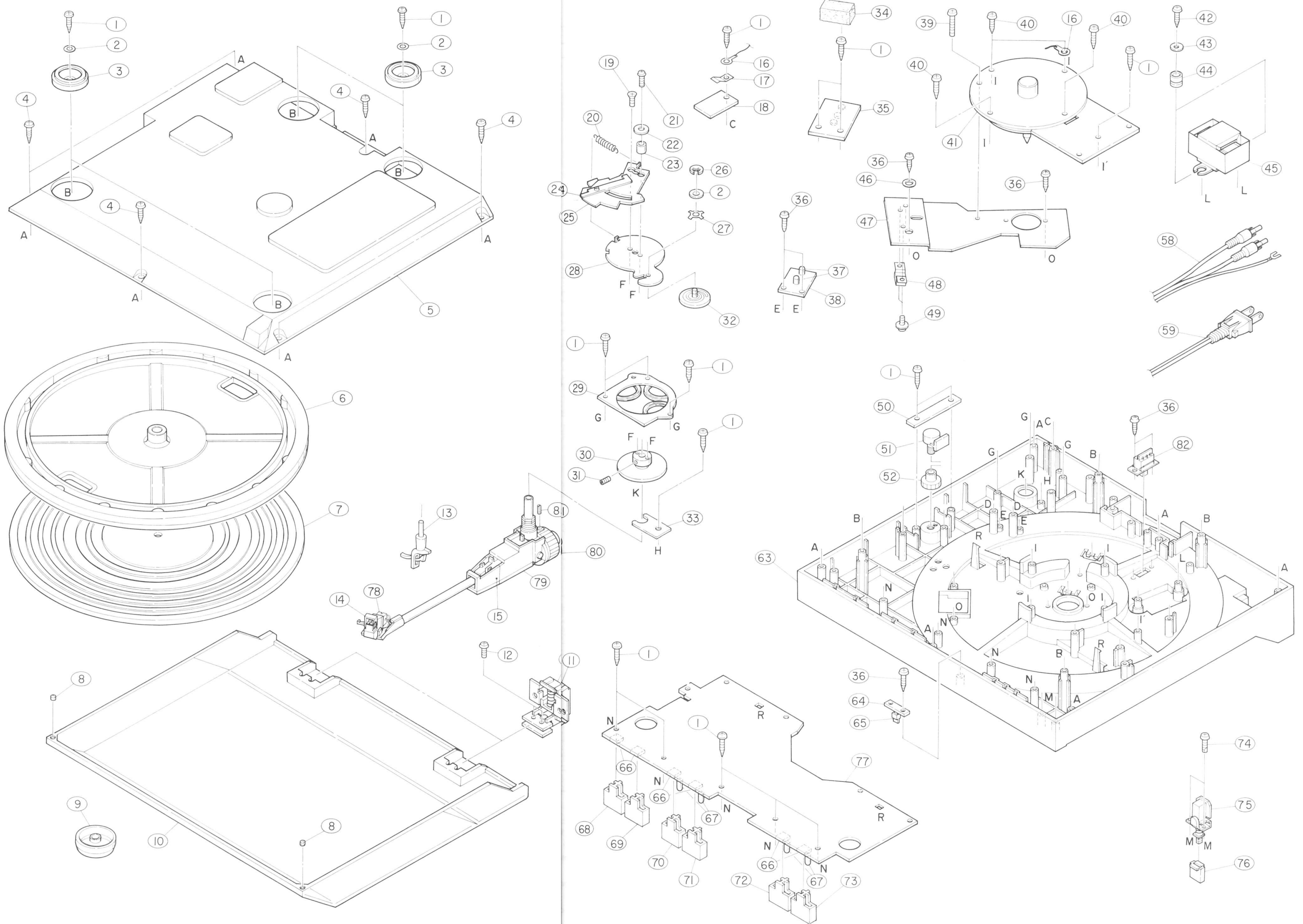

# SCHEMATIC DIAGRAM

## DPIIF WIRING DIAGRAM

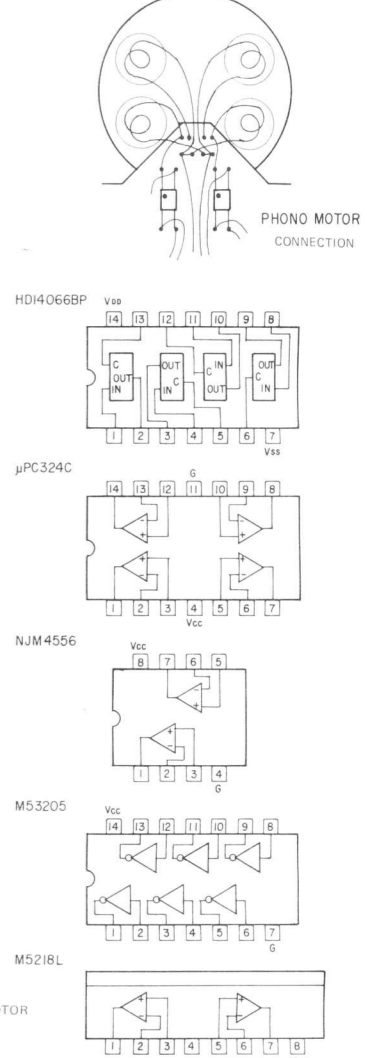
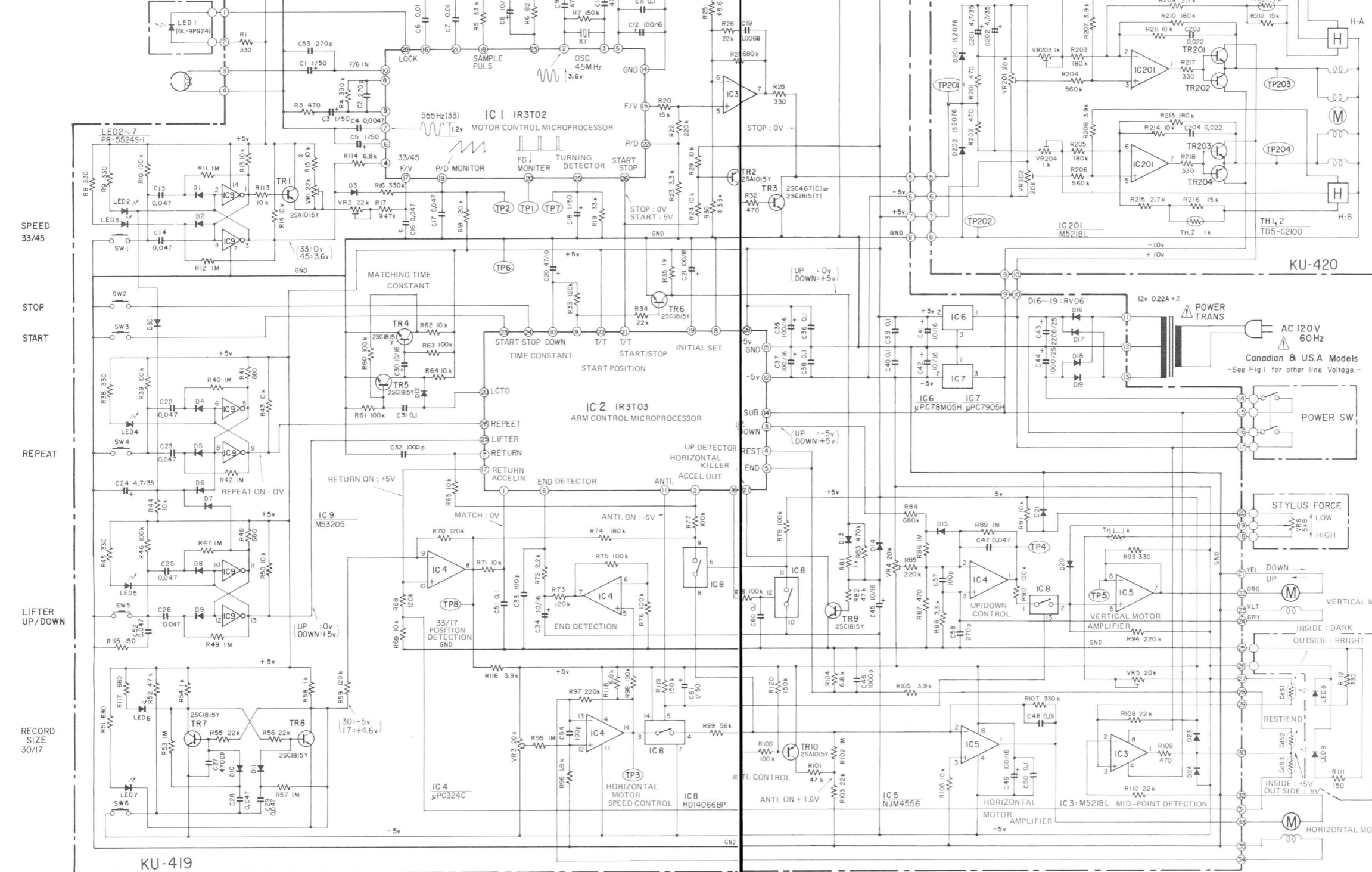

D1~5, 20, 21, 23, 24, 30I = IS2076  
LED2~7 = PR55245-1

- Note:**
- Resistance shall be 1/4W unless otherwise specified and the unit is Ω.
  - The unit of capacitor is μF, P is pF unless otherwise specified.
  - Parts marked with  $\Delta$  are of importance in respect to the safety, use the specified type without fail.
  - The voltage values are measured using the circuit tester (DC 100 kΩ/V).
  - This circuit diagram shows the basic circuit. It is subject to change for the purpose of improvement.
  - The anti-skating will be turned ON approximately five seconds after the arm starts to go DOWN.
  - A "match" denotes the condition where the arm is positioned on the edge of a 30 or 17cm record.
  - "30" denotes a 30cm record being played; "17" denotes a 17cm record.
  - "33" denotes the record speed for 33 1/3rpm; "45" denotes 45rpm.

### Fig 1 OTHER LINE VOLTAGE

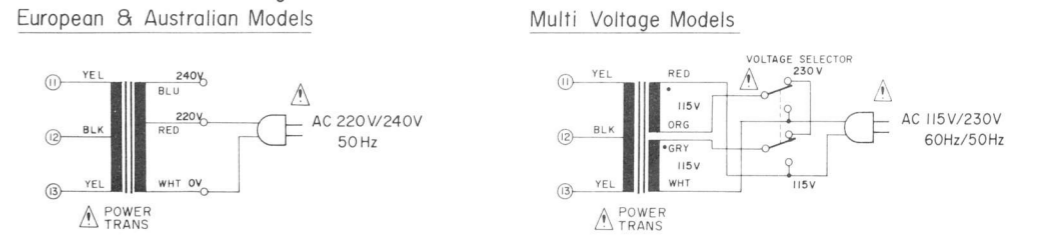

PRINTED CIRCUIT BOARD

KU-420 MOTOR DRIVE UNIT

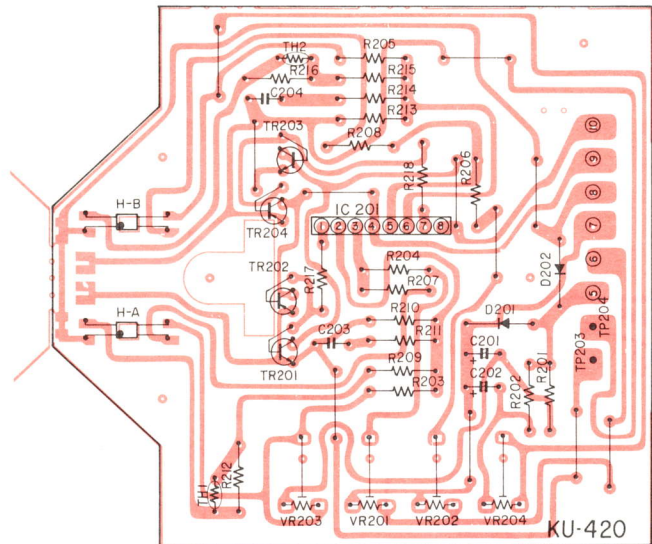

KU-419 SERVO CONTROL UNIT

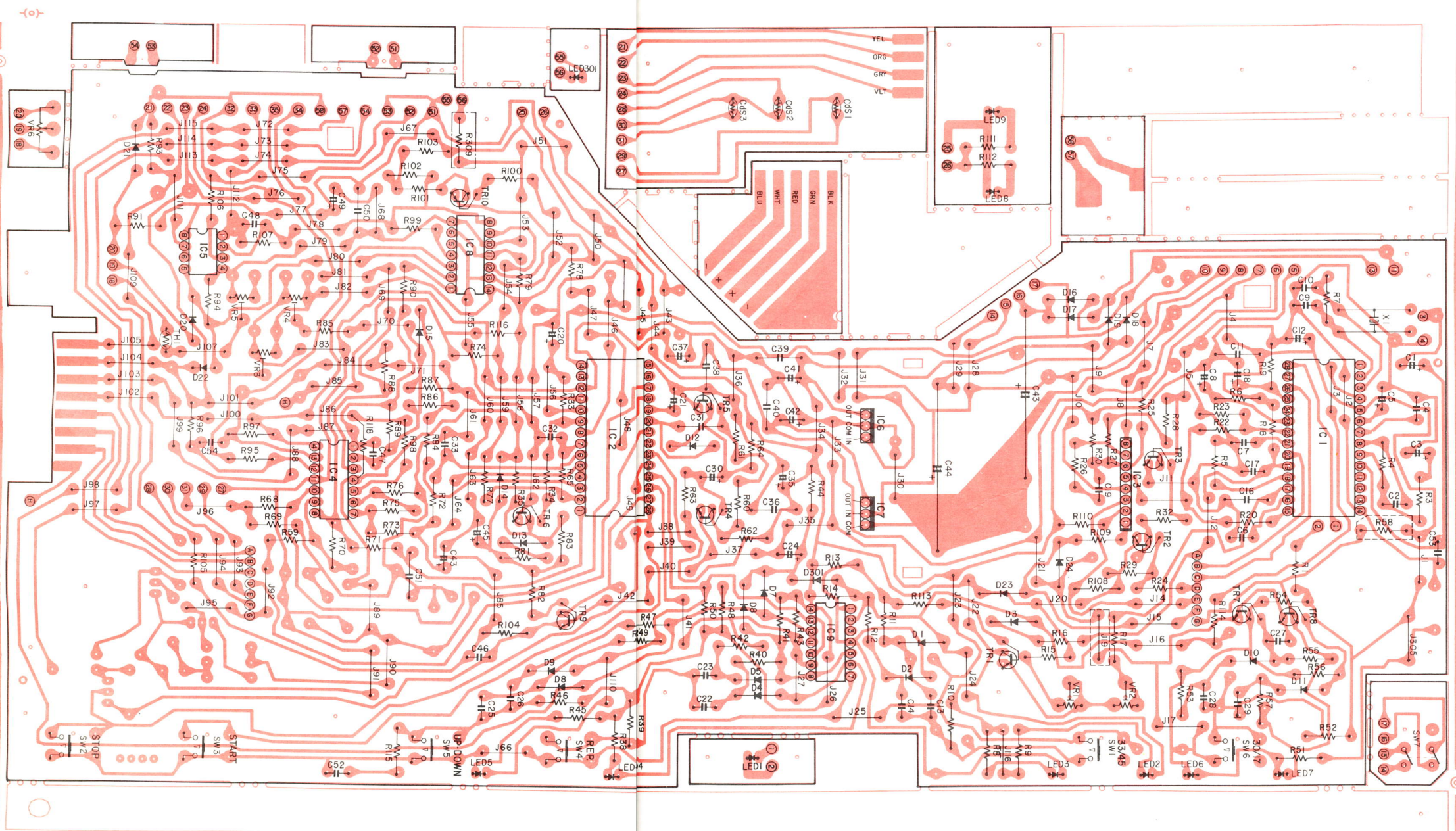

DP11F/12F

CONNECTIONS OF P. C. BOARD

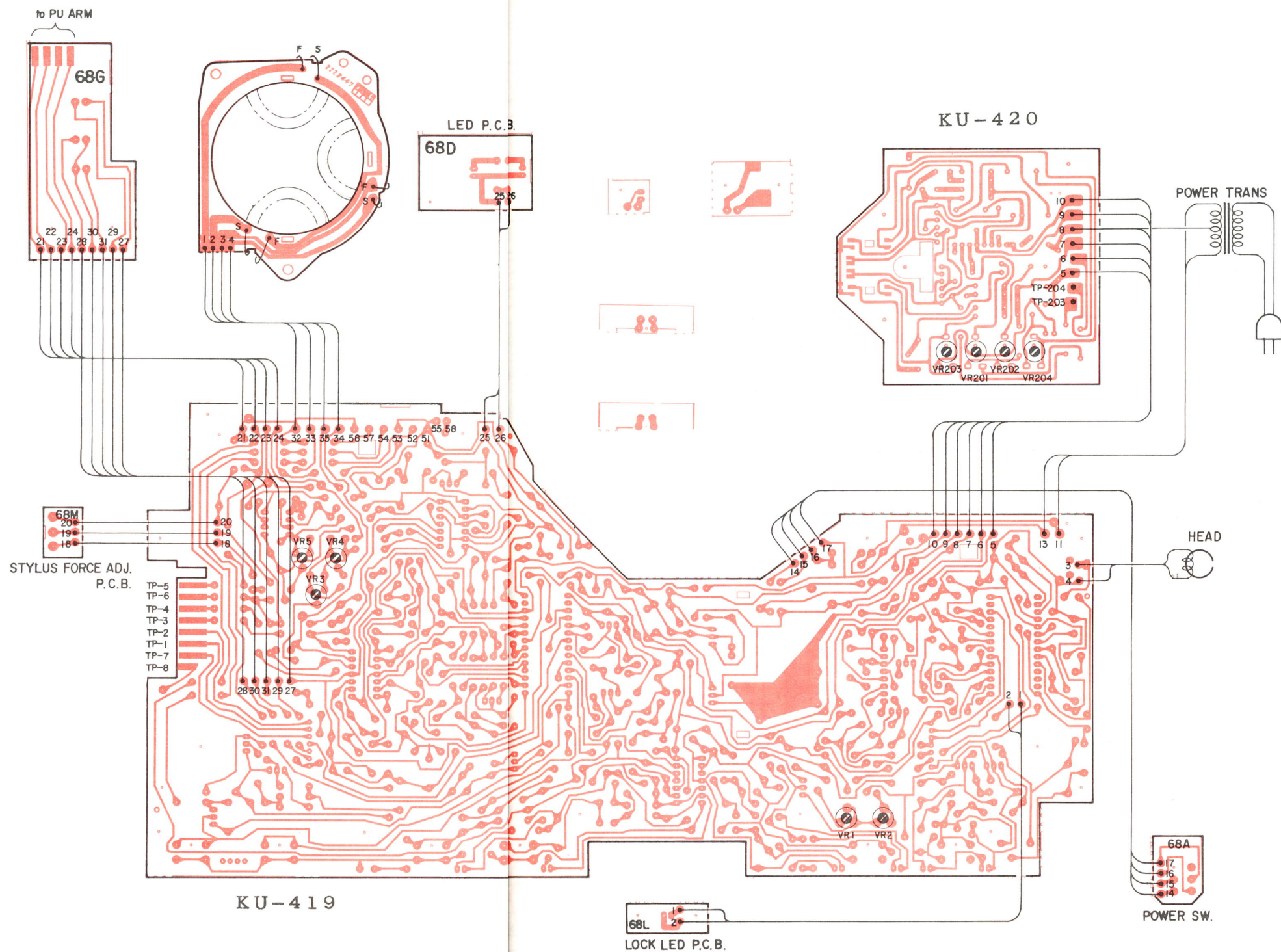



# PARTS LIST OF P. C. BOARD

## KU-419 SERVO CONTROL UNIT

Ref. No.	Part No.	Part Name	Remarks
<b>SEMICONDUCTOR GROUP</b>			
IC1	2630173004	IR3T02	
IC2	2630174003	IR3T03	
IC3	2630189001	M5218L	
IC4	2630146002	μPC324C	
IC5	2630198005	NJM4556	
IC6	2630147001	μPC78M05H	
IC7	2630160004	μPC7905H	
IC8	2620276005	HD14066BP	
IC9	2620092001	M53205P	
TR1, 2, 10	2710102005	2SA1015 (Y)	
TR4~9	2730198002	2SC1815 (Y)	
TR3	2740038000	2SD467 (C)	
D1~15, 20	2760049008	IS2076	
21, 23, 24, 301			
D16~19	2760237001	RV06	
TH1	2760311008	THERMISTER	TD5-C210D
LED1	3939140009	LED	GL-9PG24
LED2~7	3939153009	LED	PR-5524S-1
LED8, 9	3939041001	LED	LN81RCP(HL)
CDS1, 2	3939053001	CDS	
CDS3	3939053028	CDS	10~15KΩ
<b>RESISTOR GROUP</b>			
			Metal film
R30	2452195008	RN14K2E332G	3.3KΩ ¼W
R25	2452201002	RN14K2E562G	5.6KΩ ¼W
R15	2452207006	RN14K2E103G	10KΩ ¼W
R17	2452223006	RN14K2E473G	47KΩ ¼W
			Variable resistor
VR1, 2	EP-5462H15	SOLID VOLUME	22KΩ
VR3~5	2116000073	V08PB203	20KΩ
VR6	2118024002	V16V15KB502	5KΩ
<b>CAPACITOR GROUP</b>			
			Ceramic
C33, 54	2531055069	CK45B1H101K	100PF 50V
C27	2531008003	CK45B1H472K	0.0047μF 50V
			50V
C32, 46	2531004007	CK45B1H102K	0.001μF 50V
C4	2531008003	CK45B1H472K	0.0047μF 50V
			50V
C11, 31, 36, 38~40, 50, 51, 60	2531027000	CK45F1H104Z	0.1μF 50V
C9, 10	2533619005	CD45SL1H470J	47PF 50V
C57	2533657009	CC45SL1H101K	100PF 50V
C58	2533662007	CC45SL1H271K	270PF 50V
C2, 53	2533637003	CC45SL1H271J	270PF 50V
			Electrolytic
C20	2544129005	CE04W1A470=	47μF 10V
C8, 30, 41, 42, 45, 34	2544132005	CE04W1C100=	10μF 16V
C12, 21, 35, 37, 49	2544136001	CE04W1C101=	100μF 16V
C44	2542037005	CE02W1E102=	1000μF 25V
C43	2542038004	CE02W1E222=	2200μF 25V
C24	2544140000	CE04W1VR7=	4.7μF 35V
C61	2544044009	CE04W1H010	1μF 50V
C1, 3, 5, 18	2544119905	CE04W1H010=	1μF 50V
			Film
C16	2554194017	CQ93P1H473J	0.047μF 50V

• The carbon resistors rated at ¼W are not listed herein.

Ref. No.	Part No.	Part Name	Remarks
<b>OTHER PARTS GROUP</b>			
SW1~6	2228468008	SERVO CONTROL P.C.B.	
	2129130008	PUSH SWITCH	
	2129180003	PUSH SWITCH	POWER SW
	3998025000	CRYSTAL	4.5 MHZ
	4178028101	HEAT SINK	
	4450033005	WIRE CLAMP BAND	

## KU-420 MOTOR DRIVE UNIT

Ref. No.	Part No.	Part Name	Remarks
<b>SEMICONDUCTOR GROUP</b>			
IC201	2630189001	M5218L	
TR202, 204	2710105002	2SA966 (Y)	
TR201, 203	2730201009	2SC2236 (Y)	
H-A, H-B	2760303016	HL-300C	
TH1, 2	2760311008	THERMISTER	TD5-C210D
<b>RESISTOR GROUP</b>			
V203, 204	2116000031	V08PB102	
V201, 202	2116000073	V08PB203	
<b>CAPACITOR GROUP</b>			
C202	2544034006	CE04W1V4R7	
C201	2544140000	CE04W1V4R7=	
C203, 204	2551076002	CQ93M1H223K	
<b>OTHER PARTS GROUP</b>			
	2228477002	MOTOR DRIVE P.C.B.	
	2050134908	IM TERMINAL PIN	
	2090047903	0.6 JUMPER WIRE	

## CARTONE CASE GROUP

Ref. No.	Part No.	Part Name	Remarks
	5018228222	CARTON CASE ASS'Y	
	5028060001	PACKING ASS'Y	
	5058092023	LAMINATE ENVELOPE	
	5058017011	ENVELOPE	60x260x0.03
	5058006006	ENVELOPE	60x100x0.03
	5058023018	ENVELOPE	350x640x0.05

## ACCESSORIES GROUP

Ref. No.	Part No.	Part Name	Remarks
	5298006002	45 ADAPTOR	
	4218288005	RUBBER SHEET	
	5118208003	INSTRUCTION MANUAL	E2, EA, EK, E1, EU
	5118211003	INSTRUCTION MANUAL	EF
	5118212002	INSTRUCTION MANUAL	EG
	3158547001	SHELL ACCESORIES ASS	EU
	3158752003	ALIGNMENT PLATE	
	2033667007	PLUG ADAPTOR	E1