

DENON

Hi Fi Component

SERVICE MANUAL

FULLY AUTOMATIC DIRECT DRIVE TURNTABLE SYSTEM

MODEL DP-15F SERIES

U.S. and Canadian models do not include cartridge.



NIPPON COLUMBIA CO., LTD.

BLOCK DIAGRAM

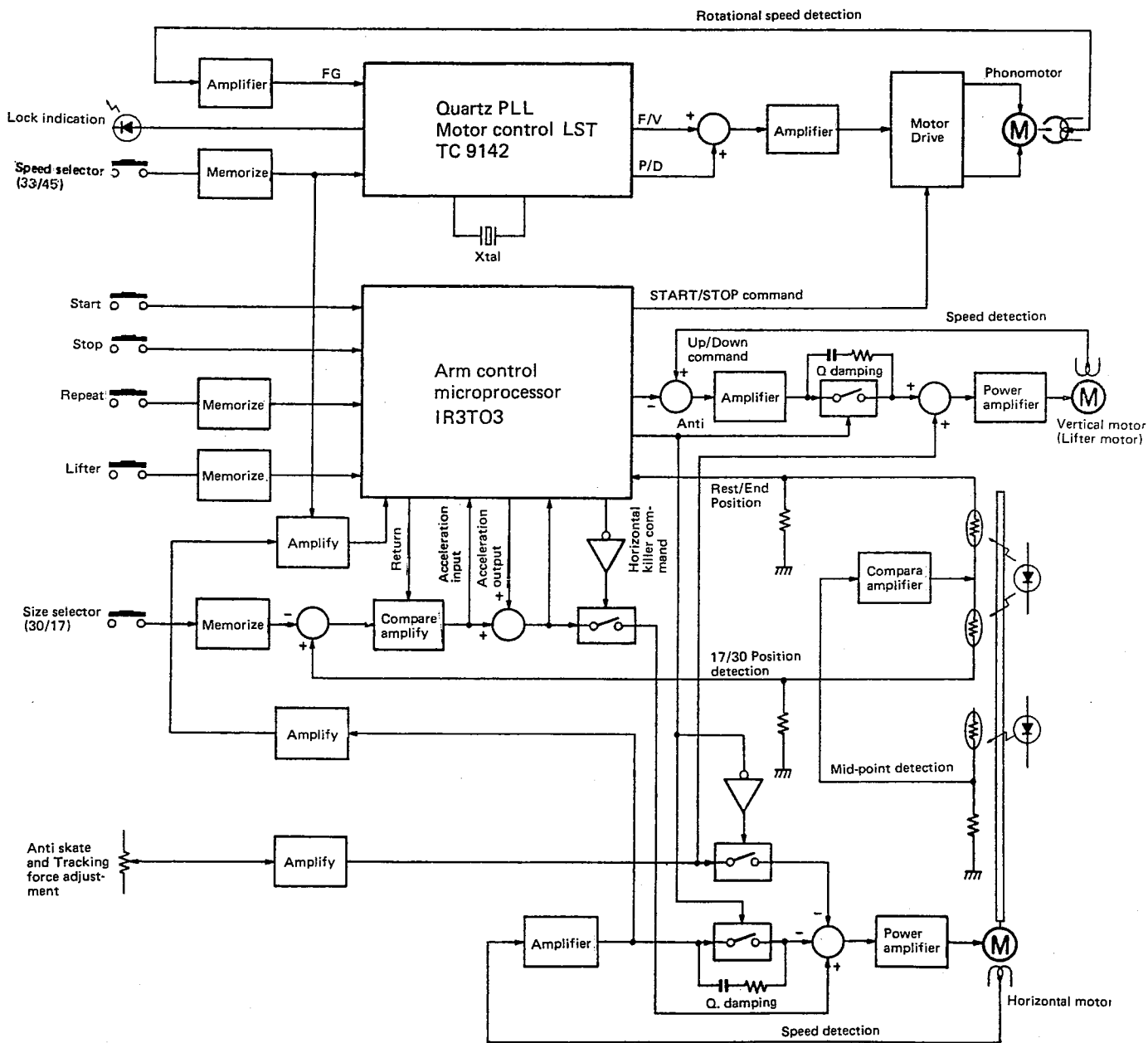

PART NAMES AND FUNCTION

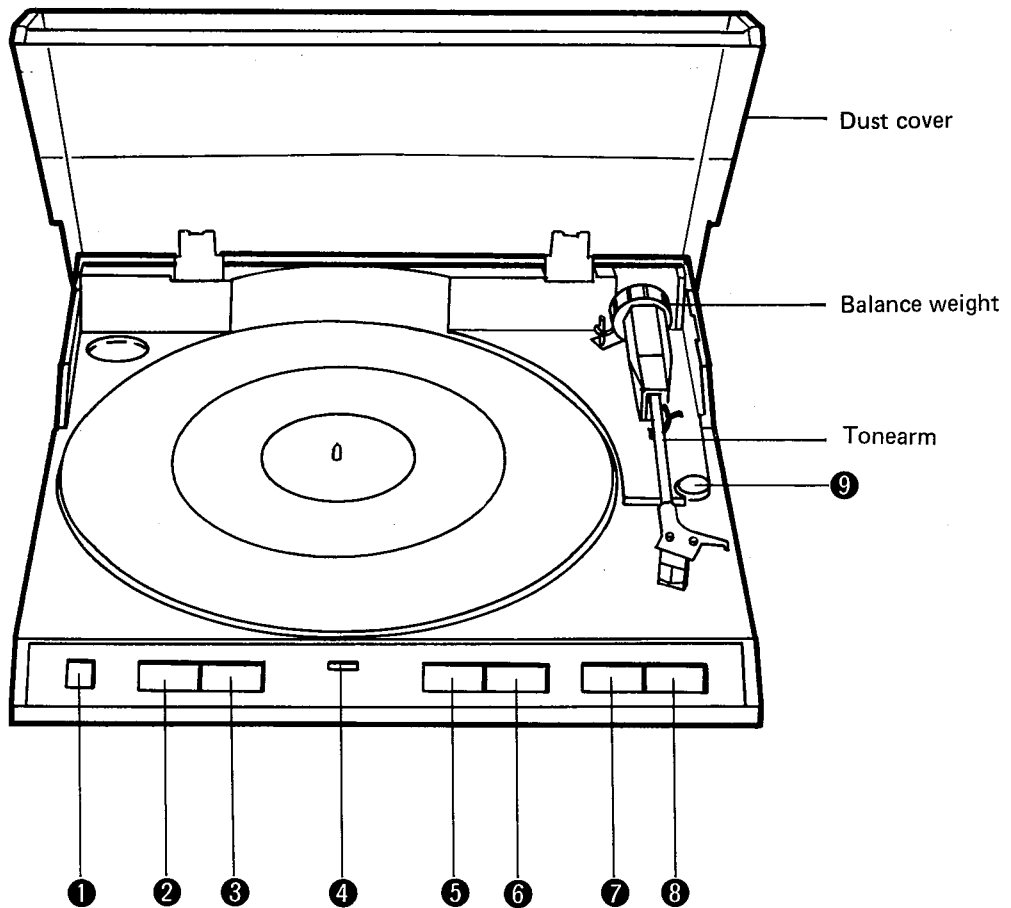

1 POWER (Power switch)

This switch turns the power supply on (—) and off (■). When turning the power off, always return the tonearm to the arm rest and hold it in place with the clamp.

2 SIZE (Record size selector switch)

Set to the size of record to be played.
 30 cm records "30" (lamp lit)
 17 cm records "17" (lamp lit)

3 SPEED (Speed selector switch)

Set to the desired record speed.
 33-1/3 rpm records "33" (lamp lit)
 45 rpm records "45" (lamp lit)

4 LOCK (Lock indicator)

The lamp will light when the turntable reaches a nominal r.p.m. speed in the Play mode.

5 ARM LIFTER (Arm lifter switch)

This switch is used to raise and lower the arm during play or when playing the records manually. The lamp is lit when arm is up.

6 REPEAT (Repeat switch)

When playing the records repeatedly, switch it on (lamp lit).

7 START (Start switch)

Press this switch when starting the records automatically.

8 STOP (Stop switch)

Press this switch when stopping the record during play.

9 TRACKING FORCE (Tracking force adjustment knob)

This knob is used to adjust the tracking force and anti-skating amount.

ADJUSTMENT METHOD

• PHONO MOTOR ADJUSTMENT

1. Off-set adjustment

- 1) Set the X-axis and Y-axis sensitivity of the oscilloscope to 100mV/cm by using a 10:1 probe.
- 2) Connect the X-axis terminal of the probe with TP-203 on the motor drive base board and the Y-axis terminal of the probe with TP-204. Use pin No. 8 as the ground.
- 3) Connect pin No. 5 and pin No. 8 and make a low resistance circuit on the input terminal.
- 4) Stop the rotor at the maximum position of the X-axis amplitude of the Lissajous' figure of the oscilloscope while turning the motor by hand.
- 5) Set the maximum amplitude at the X-axis by adjusting VR-201. $A = A'$
- 6) Stop the rotor at the maximum position of the Y-axis amplitude of the Lissajous' figure.
- 7) Set the maximum amplitude at the Y-axis by adjusting VR-202. $B = B'$
- 8) Adjust the center of the circle to $\pm 50\text{mV}$.

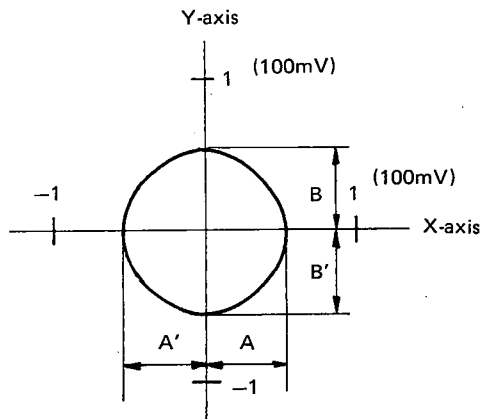

- 9) Disconnect pin No. 5 and pin No. 8 after adjustment.

2. Amplitude adjustment

- 1) Remove the arm from the arm rest and remove the turntable. Then, turn the motor with full speed.
- 2) Set the amplitude of the X-axis and Y-axis of the Lissajous' figure to 15 V^{P-P} by adjusting VR-203 and VR-204. Make sure that there is no voltage difference between the X-axis and the Y-axis.

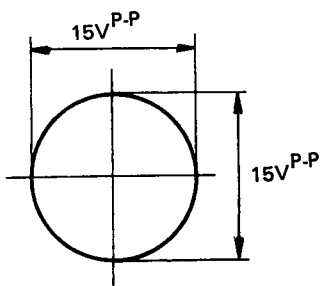

3. Adjusting the head gap

Adjust, so that the gap between the turntable magnetic coating surface and the detection head is 0.18 mm.

4. Checking the 33 r.p.m. and 45 r.p.m. locks

From now on, use test point TP-1 of the servo control circuit board as the earth reference point of the measuring instrument.

- 1) Connect an oscilloscope to test point TP-6.
- 2) Make sure to check that the voltage of TP-6 at normal speed is approximately 2.2 V.

● ADJUSTING THE ARM CONTROL SECTION

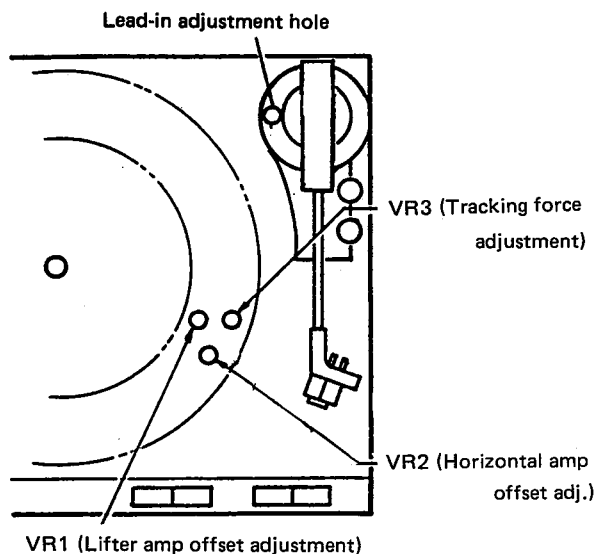

1. Adjusting the horizontal OP amp. offset voltage

- 1) Fix the tonearm to the arm rest and connect the oscilloscope to TP-3.
- 2) Set the lifter switch to the UP condition.
- 3) Turn VR-2 and adjust to $0V \pm 0.01V$.

2. Adjusting the lifter OP amp. offset voltage

- 1) Fix the tonearm to the arm rest and connect the oscilloscope to TP-4.
- 2) Set the lifter switch to the DOWN condition.
- 3) After about 7 seconds, adjust to $-1V \pm 0.1V$ by turning VR-1.

3. Adjusting the tracking force

- 1) Turn the power supply switch OFF.
- 2) Take the arm off the arm rest. Rotate the balance weight so that the tonearm becomes parallel to the turntable surface when let go.
- 3) Return the arm to the arm rest and turn the power supply switch ON.
- 4) Wait seven seconds after the arm has lowered. Place the cartridge stylus tip onto a tracking force gauge and set the tracking force adjustment knob to 1.5 g.
(Note) At this time, the stylus tip height should be adjusted so that it is about the same height as during play.
- 5) Turn VR-3 and adjust, so that the tracking force gauge reads 1.5 g. (Turn VR slowly.)

4. Adjusting the 30 cm lead-in position

- 1) Place a 30 cm record on the turntable and set the record size selector switch to "30".
(Note) Keep the bottom cover closed.
- 2) Move the arm so that the stylus tip is approximately at the 30 cm lead-in position. Insert a small flat-headed screwdriver into the lead-in adjustment hole; move the arm back and forth and fit the screw driver into the groove of the cam inside gently.

- 3) After turning the screwdriver, pull it out once. Press the start switch and adjust so that the stylus position stops at the 30 cm lead-in position.

(Note) The 30 cm lead-in adjustments cannot be performed unless the stylus tip position is approximately in the 30 cm lead-in position. In addition, if the screwdriver is left inserted, the arm will not move.

5. Adjusting the 17 cm lead-in position

Adjust as necessary, such as when parts of the sensor section have been replaced.

However, the following procedures should only be used when a discrepancy is found for the 17 cm lead-in position, after the 30 cm lead-in position has been adjusted.

- 1) Set the record size selector to 17 cm.
- 2) By continuously pressing the start switch, the arm will move over and stop. At this time, check how many millimeters, toward the inside or outside, the stylus tip deviates from the required 17 cm lead-in position.
- 3) Take off the bottom cover of the cabinet and check the adjustment scale position of the shutter. (One adjustment scale corresponds to a stylus tip movement of 0.5 mm.)
- 4) Untighten the screw holding the sub shutter and place a small flat-headed screwdriver into the slot of the shutter. When the stylus position is toward the inside, compared to the required position, move the sub shutter toward the right of the scale; when the stylus position is toward the outside, move the sub shutter toward the left. When completed, tentatively tighten the screw holding the sub shutter.
- 5) After the adjustments are made, press the start switch and check whether or not the stylus stops at the 17 cm lead-in position.
- 6) If the stylus stops at the required position, then tighten the sub shutter screw.

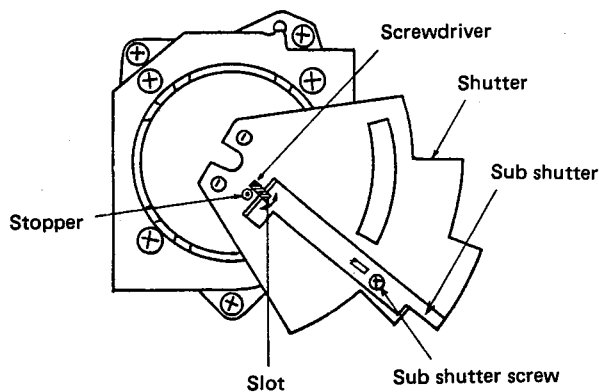

EXPLANATION HOW THE LSI QUARTZ PLL MOTOR CONTROL OPERATES

○ **LSI motor control ... TC9142P**
(33 r.p.m. is set as the standard speed)

- Due to C-MOS construction, handle this IC with extreme care.
- V_{IH} (min.) ... $0.7 \times V_{CC} = 3.5 \text{ V}$
- V_{IL} (max.) ... $0.3 \times V_{CC} = 1.5 \text{ V}$
- In terminals 4, 5, 10, and 11, pull-up resistors are built in.

Terminal 1 : GND

Terminal 2 : OSC OUT (7.68 MHz)

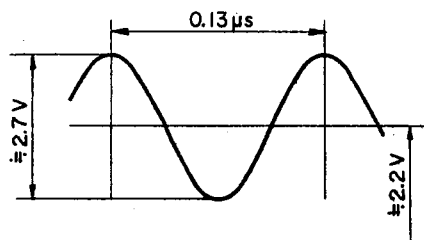

Terminal 3 : OSC IN (7.68 MHz)

Terminal 4 : Internal frequency divider ratio switch
and 5 Terminals 4 and 5 determine the frequency dividing ratio of the internal frequency divider.

Terminal 6 : FG input

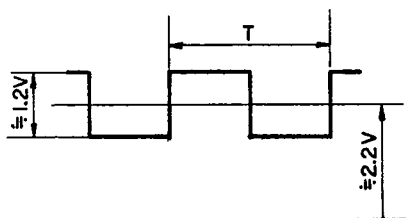

$T = 1.8 \text{ ms}$ (33 rpm)
 $= 1.33 \text{ ms}$ (45 rpm)

Terminal 7 : APC output (TP-6)
Phase control system output of the motor

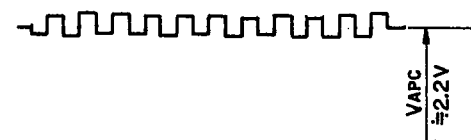

Same in either 33 rpm or 45 rpm

Terminal 8 : AFC output
Speed (frequency) control system output of the motor

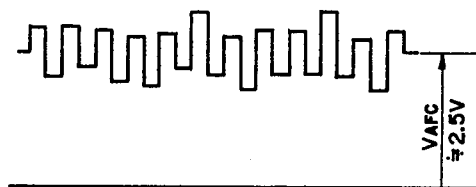

Same in either 33 rpm or 45 rpm

Terminal 10: 33/45 rpm switch input
L ... 33-1/3 rpm
H ... 45 rpm

Terminal 11: PLAY/STOP input
L ... PLAY
H ... STOP

Terminal 12: Lock detector output
Within locking range ... H
Outside locking range ... L

Terminal 14: Reference frequency input (CR IN)
Connected to terminal 15

Terminal 15: Reference frequency output (CP OUT)
In accordance with the ratio set by terminals 4 and 5, the divided frequency output is obtained.
 $7.68 \times 10^6 \div 4 = 1.92 \text{ MHz}$ (center value)
(When terminal 4: H and terminal 5: L)

Terminal 16: Line voltage (V_{CC})
 $V_{CC} = 5 \text{ V} \pm 0.25 \text{ V}$

PARTS LIST OF P. W. BOARD

KU-5120 SERVO CONTROL UNIT

Ref. No.	Part No.	Part Name	Remarks
SEMICONDUCTOR GROUP			
IC1	2630271003	TC9142P	
IC2	2630174003	IR3T03	
IC3,8	2630257001	M-5218P	
IC4, 5	2620465007	HD7476	
IC6, 12	2630237005	LA-6358	
IC7	2630198005	NJM4556D	
IC9	2620276005	HD14066BP	
IC10	2630147001	UPC78M05H	
IC11	2630160004	UPC7905H	
TR3, 8	2710102005	2SA1015 (Y)	
TR1, 2	2730198002	2SC1815 (Y)	
4~7			
9~15			
D1~5	2760049008	IS2076	
10~16			
D6, 7, 8, 9	2960237001	RV06	
TH1	2760311008	THERMISTOR (TD5C210D)	
LED2~5	3939219008	GL-5EG23	GREEN
LED1	3939041001	LN81RP-HL	RED
6~9			
CD1, 2	3939053002	CDS	
CD3	3939053028	CDS	
RESISTOR GROUP			
R15	2410173004	RD14B2H331J	Carbon film 330Ω ¼W
VR4	2118024002	V16V15KB502	Variable Resistor 5kΩB
VR1~3	2116000073	V08PB203	20kΩB
CAPACITOR GROUP			
C10, 11	2533603008	CC45SL1H100D	Ceramic 10PF 50V
C12	2633611003	CC45SL1H220J	22PF 50V
C53, 57	2533627000	CC45SL1H101J	100PF 50V
C1, 5, 54	2533637003	CC45SL1H271J	270PF 50V
C18, 19	2531004007	CK45B1H102K	1000PF 50V
47, 49, 50			
C4, 8, 32	2531027000	CK45F1H104Z	0.1μF 60V
35, 36, 38			
40, 42 44			
51, 101, 102			
107, 108			
C9	2544128006	CE04W1A220=	Electrolytic 22μF 10V
C29, 30	2544129005	CE04W1A470=	47μF 10V
C7, 16, 26	2544132005	CE04W1C100=	10μF 16V
33, 37, 48			
C31, 34, 63	2544136001	CE04W1C101=	100μF 16V
C45	2544080005	CE04=1E102M	1000μF 25V
C43	2544086009	CE04W1E222=	2200μF 25V

Ref. No.	Part No.	Part Name	Remarks
C2, 3, 6 14, 17, 20 23, 59, 60 113	2544146004	CE04W1H010=	1μF 50V Film
C61	2551121025	CQ93M1H103J	0.01μF 50V
C46, 58	2551072006	CQ93M1H103K	0.01μF 50V
C13	2551121096	CQ93M1H393J	0.039μF 50V
C52	2551122008	CQ93M1H473J	0.047μF 50V
C55	2551080001	CQ93H1H473K	0.047μF 50V
OTHER PARTS GROUP			
X1	3998037001	CRYSTAL (7.68MHz)	
S1~6	2129218001	TACT SW	
S7	2129180003	PUSH SW	
	2050158023	2P WRAPPING TERMINAL	
	2050158036	3P WRAPPING TERMINAL	
	2050158049	4P WRAPPING TERMINAL	
	2050185038	3PWIRE HOLDER	
	2050185041	4P WIRE HOLDER	
	2050185054	5P WIRE HOLDER	
	2050185067	6P WIRE HOLDER	
	4438568107	LED HOLDER	

KU-4410 MOTOR DRIVE UNIT

Ref. No.	Part No.	Part Name	Remarks
SEMICONDUCTOR GROUP			
IC201	2630189001	M5218L	
TR201, 203	2730201009	2SC2236 (Y)	
TR202, 204	2710105002	2SA966 (Y)	
D201, 202	2760049008	IS2076	
TH201, 202	2760311008	THERMISTOR (TD5C210D)	
H-201, 202	2760303016	HL-300 (SILVER)	
RESISTOR GROUP			
VR203, 204	2116000031	V08PB102	1KΩB
VR201, 202	2116000073	V08PB203	20KΩB
CAPACITOR GROUP			
C205	2531027000	CK45F1H104Z	Ceramic 0.1μF 50V
C202	2544132005	CE04W1C100=	Electrolytic 10μF 16V
C203, 204	2551076002	CQ93M1H223K	Film 0.022μF 50V

• The carbon resistors rated at ¼W are not listed herein.

PARTS LIST OF EXPLODED VIEW

Ref. No.	Part No.	Part Name	Remarks
1	1038235202	CABINET	E1 only
	1038235312	CABINET	
2	4318094005	FRICTION SHEET	
3	3158911103	ARM REST ASS'Y	
4	1038236104	PANEL PLATE	
5	4428137001	HEAD SUPPORT	
6	4418846014	WASHER	
7	1138164008	SWITCH KNOB	
8	KU-5120	SERVO CONTROL UNIT	
9	4178028101	HEAT SINK	
10	2129180003	PUSH SW	
11	4428102007	SWITCH SUPPORTER	
⚠	2339059005	POWER TRANS.	E2
	2339050208	POWER TRANS.	EU
	2339060007	POWER TRANS.	E1
13	4620027003	RUBBER BUSH	
14	WA-10174	WASHER	
15	1138166006	POWER KNOB	
16	2178085007	MOTOR	
17	KU-4410	MOTOR DRIVE UNIT	
18	3158943401	TONE ARM ASS'Y	
19	DL-65	PICK UP CARTRIDGE	
20	4756133007	14N	
21	4338175108	YOKE (A) ASS'Y	
22	3158710100	LATERAL BALANCE	
23	2398013215	COIL ASS'Y	
24	3418025205	MAGNET ASS'Y	
25	4248019202	ADJUST CAM	
26	3158451003	FRICTION WASHER	
27	4751005004	4W	
28	4761003009	3E RING	
29	4338261009	SHUTTER	
30	4338243001	SUB SHUTTER	
31	4438545201	COLLAR	
32	4751003006	3W	
33	4638225004	SPRING	
34	4148181007	SHIELD SHEET	
35	1048076105	INSULATOR ASS'Y	
36	4438158025	SPACER	
37	2033642103	OUTPUT CORD ASS'Y	
⚠	2062002031	AC CORD	E2
	2062019008	AC CORD	EU
	2006031026	AC CORD	E1
39	3918423006	MAGNETIC HEAD	
40	1128085003	VOLUME KNOB	
41	4218312007	RECORDED TURNTABLE	
42	1058095105	BOTTOM COVER	
43	4218288005	RUBBER SHEET	
44	4761006006	6E RING	
45	1468155208	DUST COVER	
46	4628023009	BUSHING	
47	4018069000	HINGE	
48	4730304014	3x8 CBRTS (1)	
49	4730305013	3x10 CBRTS (1)	
50	4713303016	3x6 CBS	

Ref. No.	Part No.	Part Name	Remarks
51	4712303017	3x6 CFS	
52	4730309019	3x16 CBRTS (1)	
53	4733808012	3x12 CBRTS (1)	
54	4711303018	3x6 CPS	
55	4718310004	3x20 CBS	
56	4731806003	3x20 CPTS (1)	
57	4730306012	3x12 CBRTS (1)	
58	4712304016	3x8 CFS	
59	4744304000	3x3 BSS (D)	
60	4711810019	2x3 CPS	
61	4700028003	3x12 CRTS (W)	
62	4700009019	3x6 CPS W	
63	4730306038	3x12 CRTS 1 BKNI	
64	4730816007	3x16 CBRTS (1)	
65	1248025008	SHEET	
66	2118024002	VR (V16V15KB502)	
⚠	2129185008	SLIDE SWITCH	E1 only
68	4730205016	2.6x10 CBRTS (1)	E1 only

WARNING:

Parts marked with ⚠ and/or shading have special characteristics important to safety. Be sure to use the specified parts for replacement.

PACKING AND ACCESSORIES GROUP

Ref. No.	Part No.	Part Name	Remarks
	5018312015	CARTON CASE ASS'Y	
	5028122208	PACKING ASS'Y	
	5028064104	WEIGHT PACKING	
	5118259007	INSTRUCTION MANUAL	
	5118258008	INSTRUCTION MANUAL	EU only
	5298006002	45 ADAPTOR	
	5298041106	OVER HANG GAUGE	
	5058006006	ENVELOPE	60x100
	3158547001	SHELL ACCESSORY	EU only
		ASS	

Remark symbols in the parts list refer to the following countries and areas.

E1 : Multiple voltage model

E2 : European continent

EU: U.S.A. and Canada

EXPLODED VIEW

A B C D E F G H

1
2
3
4
5
6
7

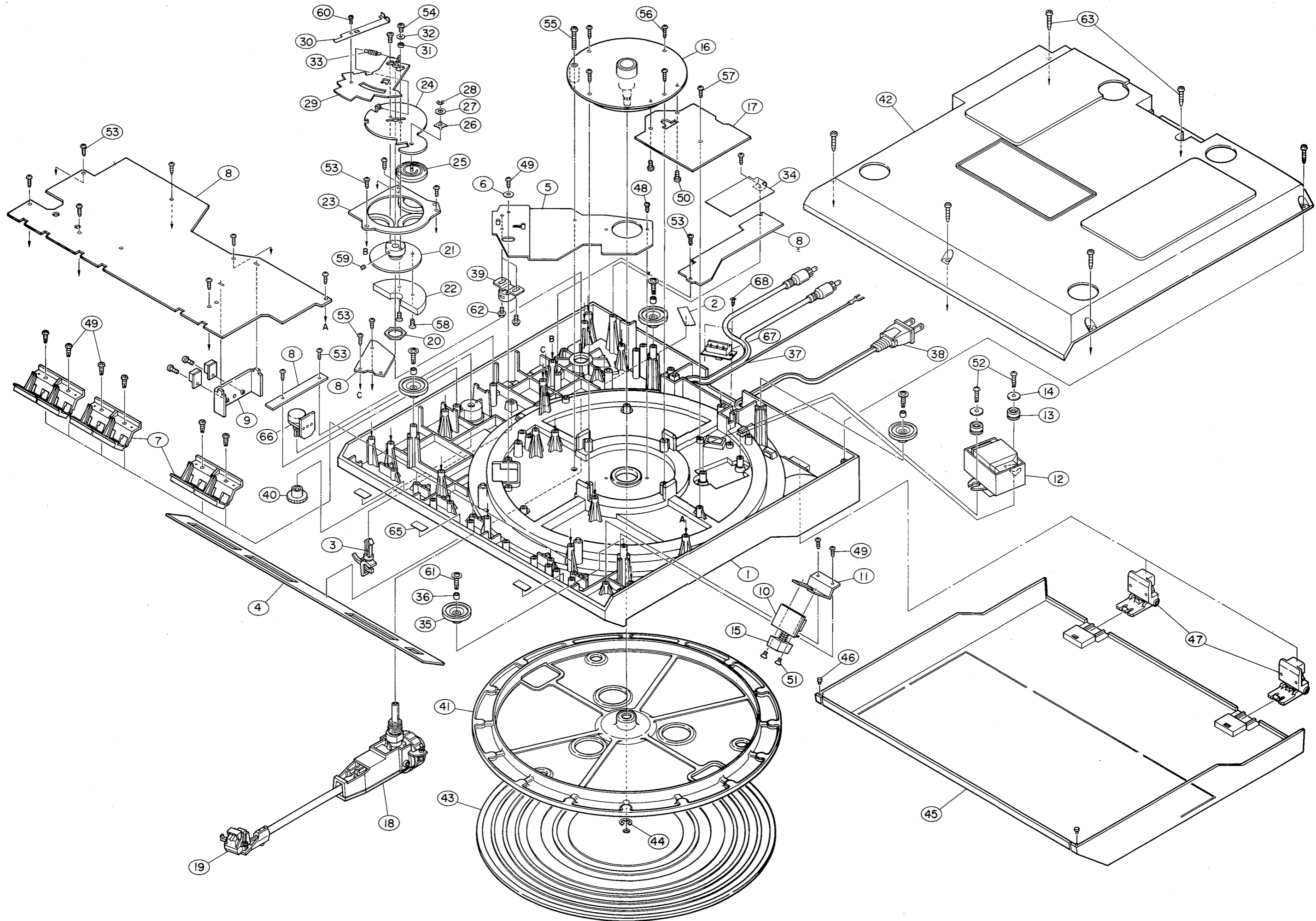

SCHEMATIC DIAGRAM

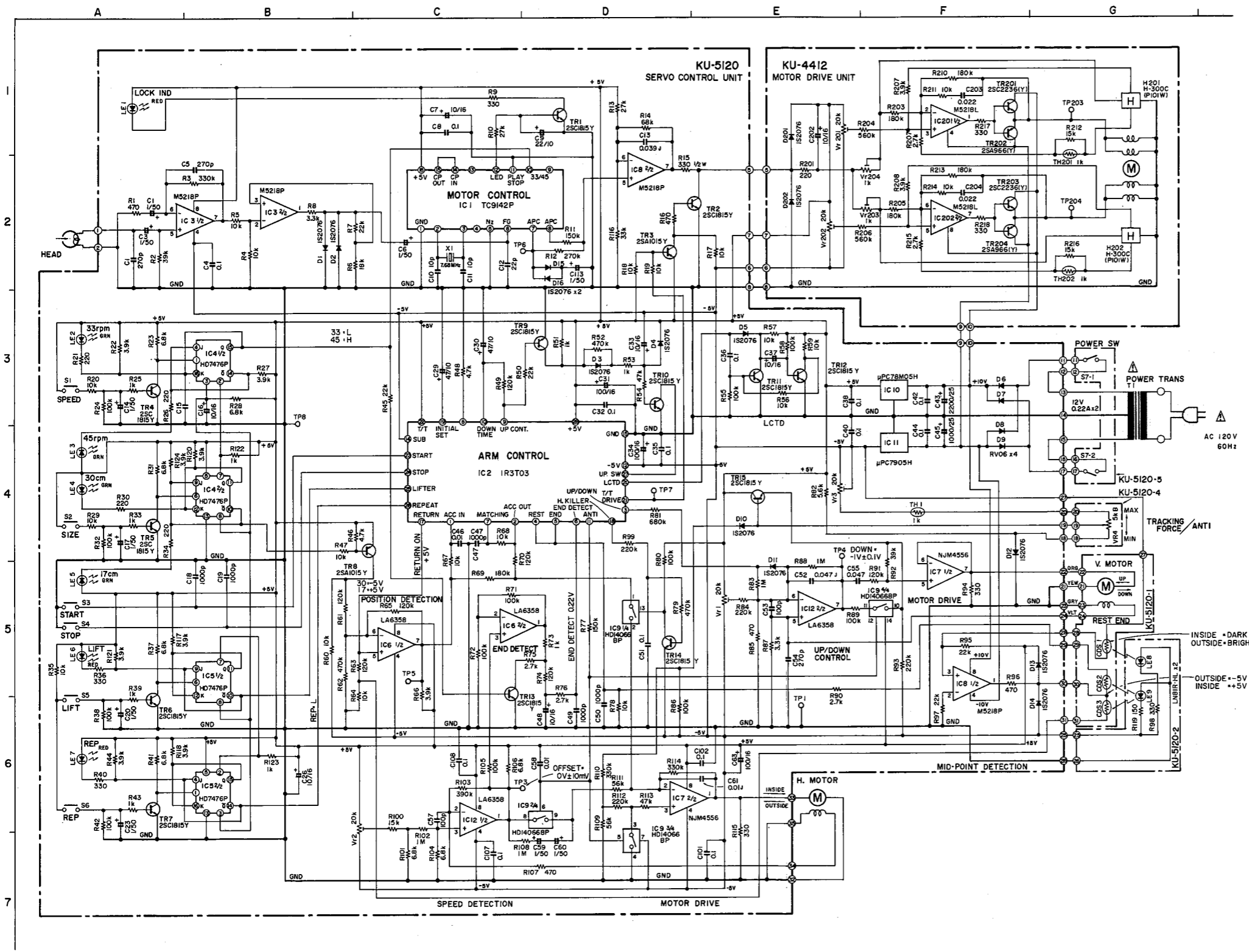

M5218L

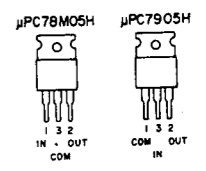
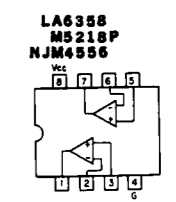
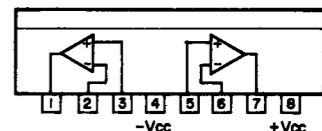

- 25A966
- 25A1015
- 25C1815
- 25C2236

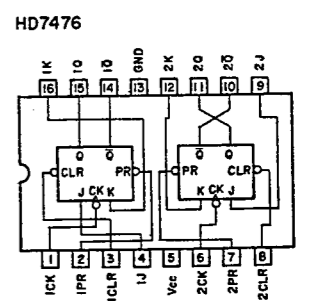
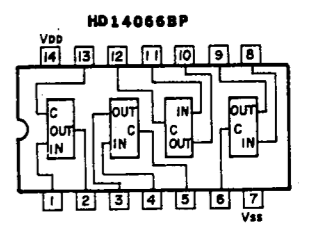
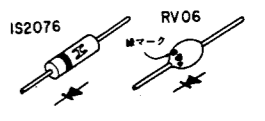
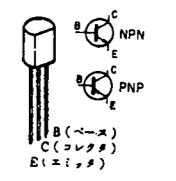

- Note:**
- Resistance shall be 1/4W unless otherwise specified and the unit is Ω.
 - The unit of capacitor is μF, P is pF unless otherwise specified.
 - This circuit diagram shows the basic circuit. It is subject to change for the purpose of improvement.
 - Parts marked with are of importance in respect to the safety, use the specified type without fail.

European & Australian Models

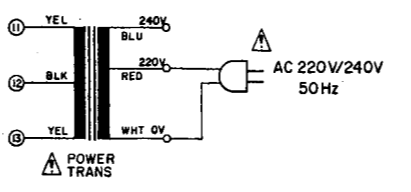

Multi Voltage Models

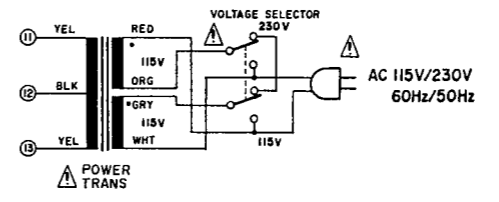

HORIZONTAL MOTOR

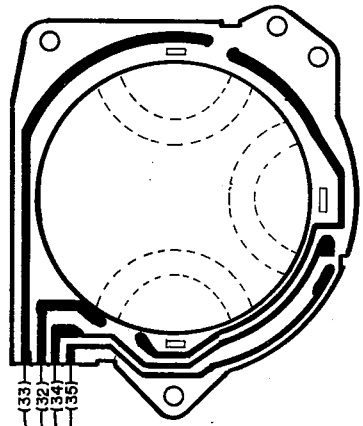

TRACKING FORCE/ANTI VOLUME

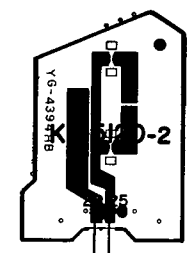
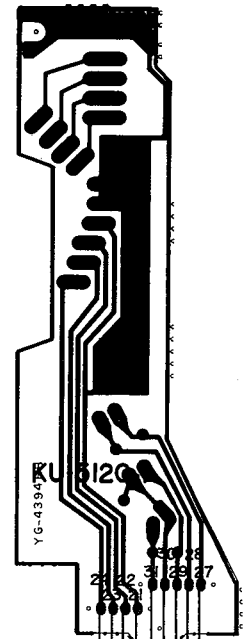
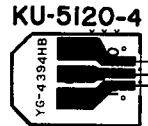

MOTOR DRIVE UNIT

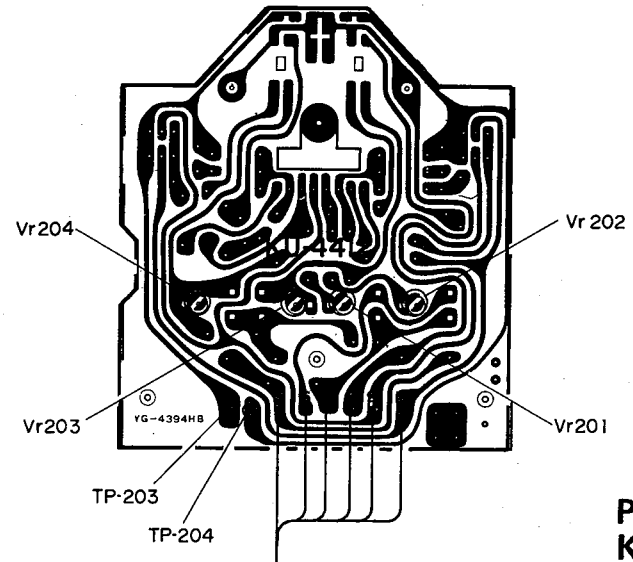

POWER SW KU-5120-5

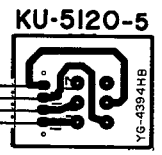

POWER TRANS

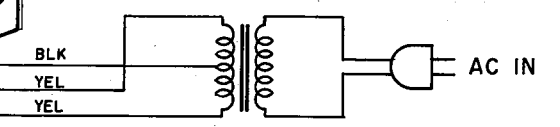

HEAD

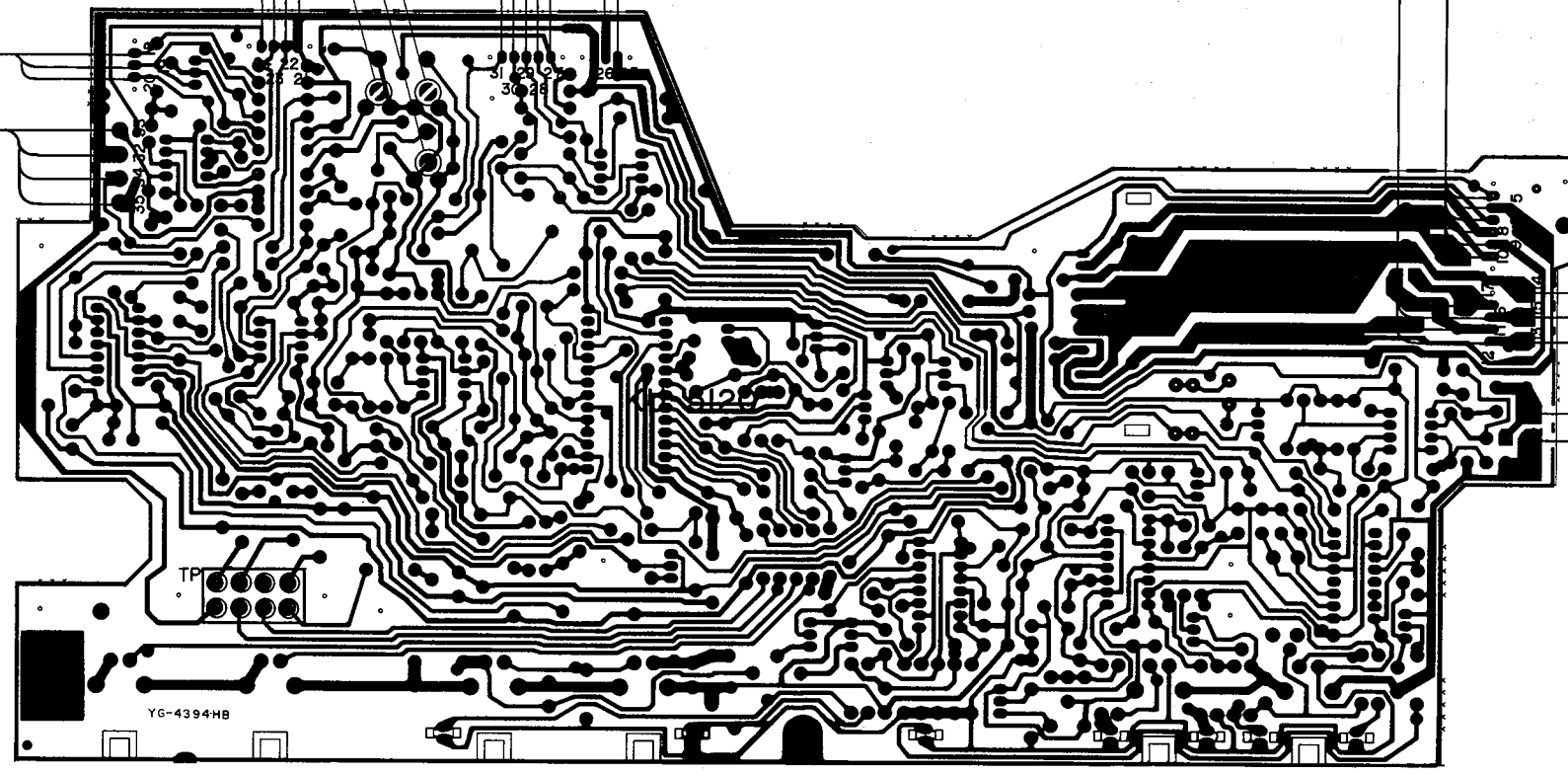
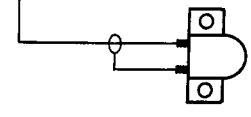

YG-4394HB

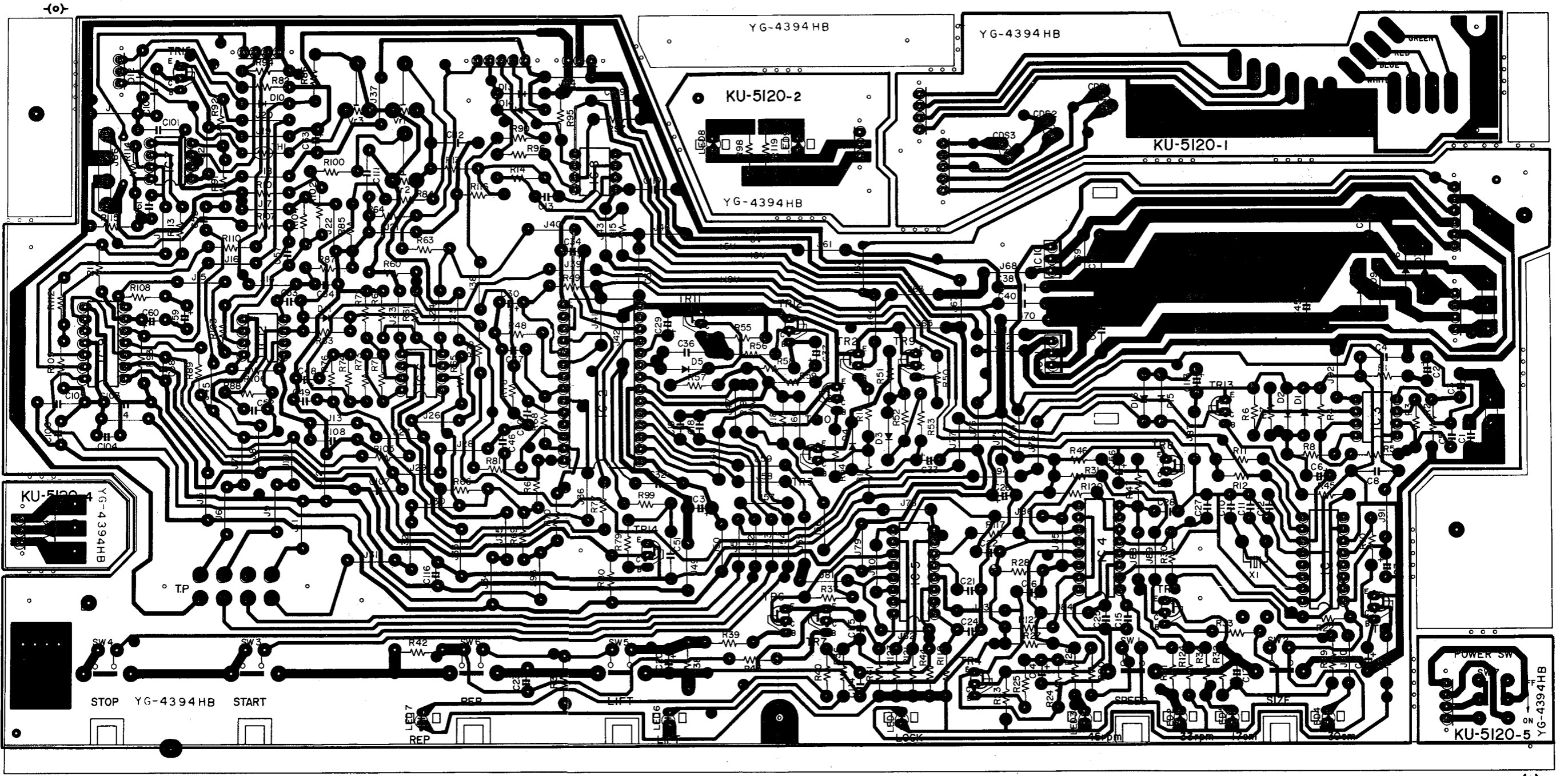

P. W. BOARD OF KU-4410 MOTOR DRIVE UNIT

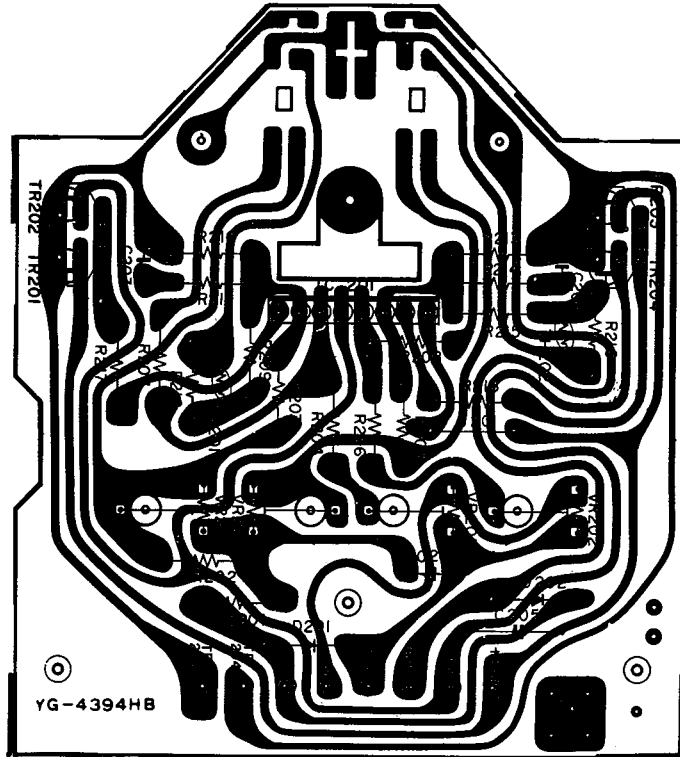

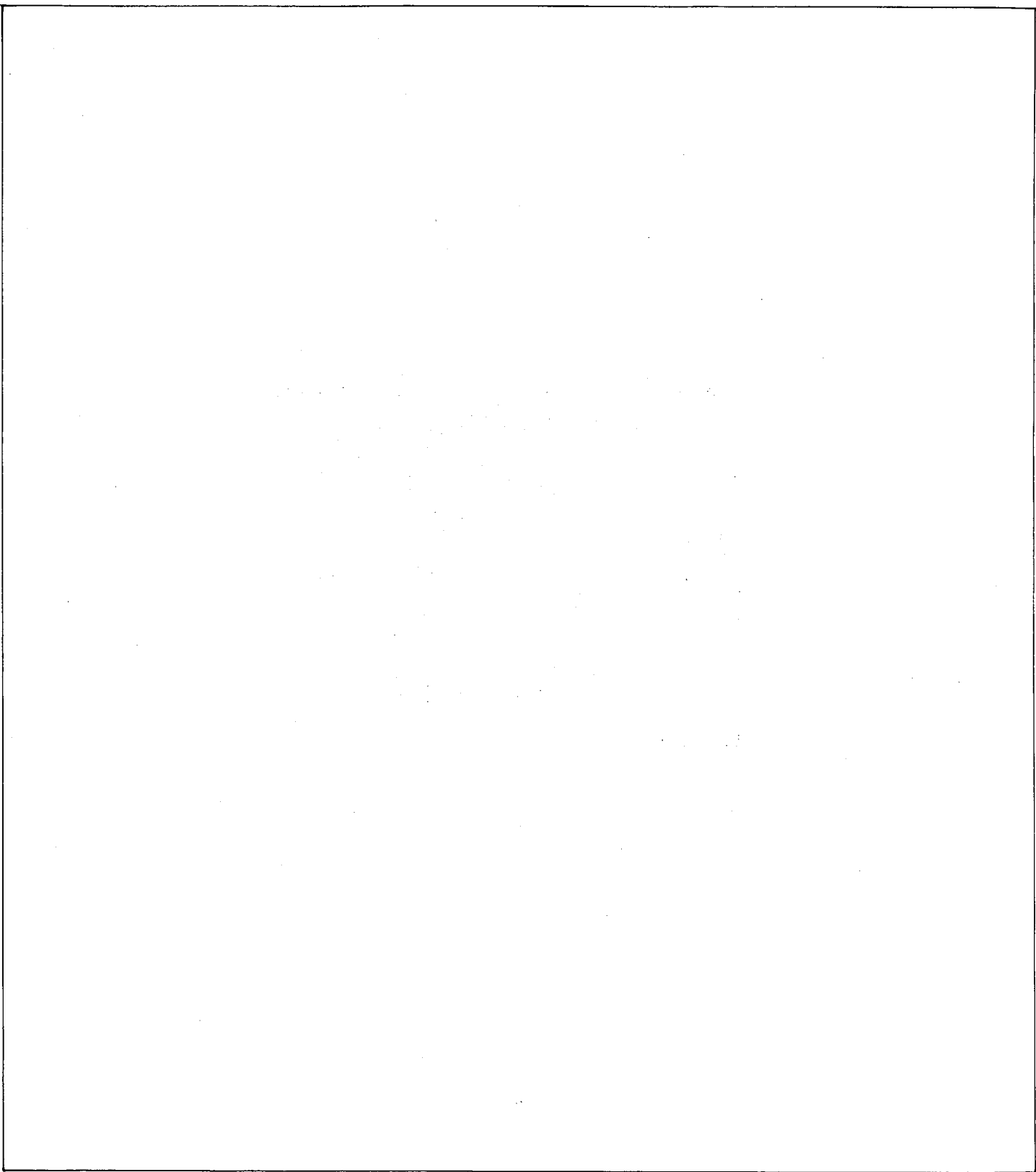

NIPPON COLUMBIA CO., LTD.

No. 14-14, 4-CHOME AKASAKA,
MINATO-KU, TOKYO JAPAN

TEL: 03-584-8111

TLX: JAPANOLA J22591

CABLE: NIPPON COLUMBIA TOKYO