

# DENON

Hi-Fi AM-FM Stereo Receiver

## SERVICE MANUAL

# MODEL DRA-1000

### AM-FM STEREO RECEIVER

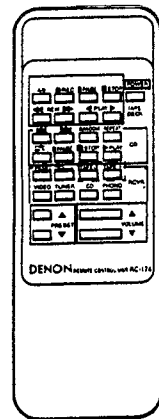
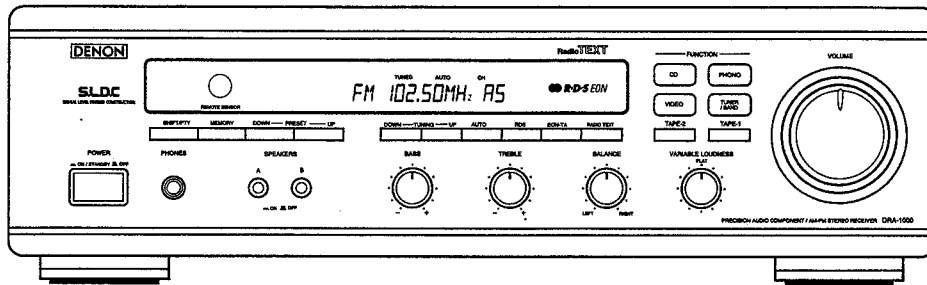

This service manual is composed of only pages whose contents are different from those for the model DRA-585RD. For servicing, refer to the previously issued service manual of DRA-585RD (for Europe and U.K. models) at the same time. 3/0

#### — TABLE OF CONTENTS —

SPECIFICATIONS .....	2
DISASSEMBLY .....	3
SEMICONDUCTOR (FLD) .....	4
NOTE FOR PARTS LIST .....	5
PARTS LIST OF P.W.B. UNIT .....	6-9
PRINTED WIRING BOARDS .....	10,11
1U-2817 MAIN UNIT ASS'Y .....	10
1U-2818 TUNER UNIT ASS'Y .....	11
1U-3204 DISPLAY UNIT ASS'Y .....	11
EXPLODED VIEW .....	12
PARTS LIST OF EXPLODED VIEW .....	13,14
SCHEMATIC DIAGRAM .....	15,16

● Some illustrations using in this service manual are slightly different from the actual set.

# NIPPON COLUMBIA CO., LTD.

## SAFETY PRECAUTIONS

The following check should be performed for the continued protection of the customer and service technician.

### LEAKAGE CURRENT CHECK

Before returning the unit to the customer, make sure you make either (1) a leakage current check or (2) a line to chassis resistance check. If the leakage current exceeds 0.5 milliamps, or if the resistance from chassis to either side of the power cord is less than 460 kohms, the unit is defective.

## SPECIFICATIONS

### AMPLIFIER SECTION

#### Continuous Power

Output (DIN):	90 W +90 W (4 $\Omega$ /ohms, 1 kHz)
Power Bandwidth (IHF):	10 Hz ~ 40 kHz (T.H.D. 0.15 % both channels driven into 8 $\Omega$ /ohms)
Total Harmonic Distortion:	0.03 % (-3 dB at rated output, 8 $\Omega$ /ohms)
Frequency Response:	PHONO RIAA Standard Curve (Recording Out-put)
	MM 20 Hz ~ 20 kHz $\pm$ 0.5 dB

Input Sensitivity and Impedance:	CD, VIDEO,	
	TAPE 1, TAPE 2	20 Hz ~ 50 kHz $\pm$ 1.5 dB (at 1 W)
	PHONO MM	2.5 mV 47 k $\Omega$ /kohms
	CD, VIDEO,	
	TAPE 1, TAPE 2	150 mV 25 k $\Omega$ /kohms

Maximum Input Level (at 1 kHz):	PHONO MM	120 mV
Signal to Noise Ratio (IHF-A):	PHONO MM	78 dB (at 5.0 mV input)

Tone Controls:	CD, VIDEO,	
	TAPE 1, TAPE 2	98 dB
	BASS	$\pm$ 10 dB at 100 Hz
	TREBLE	$\pm$ 10 dB at 10 kHz

Loudness Control Effect:	Variable Loudness at maximum position 50 Hz/10 kHz, +10 dB/+5 dB
--------------------------	--

### TUNER SECTION

[FM] (note:  $\mu$ V at 75  $\Omega$ /ohms, 0 dBf =  $1 \times 10^{-15}$  W)

Receiving Range:	87.50 ~ 108.00 MHz
Usable Sensitivity:	0.9 $\mu$ V (10.3 dBf)
Signal to Noise Ratio (IHF-A):	MONO: 82 dB
	STEREO: 78 dB
Image Rejection:	65 dB
Selectivity ( $\pm$ 300 kHz):	55 dB
Frequency Response:	30 Hz ~ 15 kHz $^{+0.2}_{-1.5}$ dB
Stereo Separation (at 1 kHz):	40 dB

[AM]

Receiving Range:	522 ~ 1611 kHz
Usable Sensitivity:	18 $\mu$ V
Signal to Noise Ratio:	55 dB

### GENERAL

Power Supply:	AC 230 V 50Hz
Power Consumption:	190 W
Power Outlet:	SWITCHED 100 W
Dimensions:	434 mm (W) $\times$ 134 mm (H) $\times$ 366 mm (D)
Weight:	8.5 kg

### REMOTE CONTROL UNIT

Remote Control System:	RC-174
Remote Control System:	Infrared pulse system
Power Supply:	3 V DC Two size "AA" (R6) dry cell batteries
External dimensions:	60 mm (W) $\times$ 175 mm (H) $\times$ 18 mm (D)
Weight:	120 g (includes batteries)

# DISASSEMBLY

(To reassemble reverse disassembly)

## 1. Top Cover

- (1) Remove 8 screws ①.
- (2) Remove 2 screws ②.

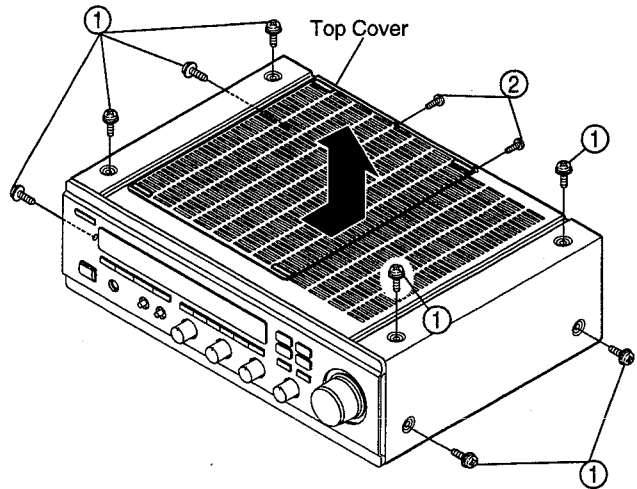

## 2. Front Panel

- (1) Pull out Volume knob ③.
- (2) Remove nut ④.
- (3) Remove Volume Plate ④-1.
- (4) Remove 6 screws ⑤ and undo hooks at 3 places.

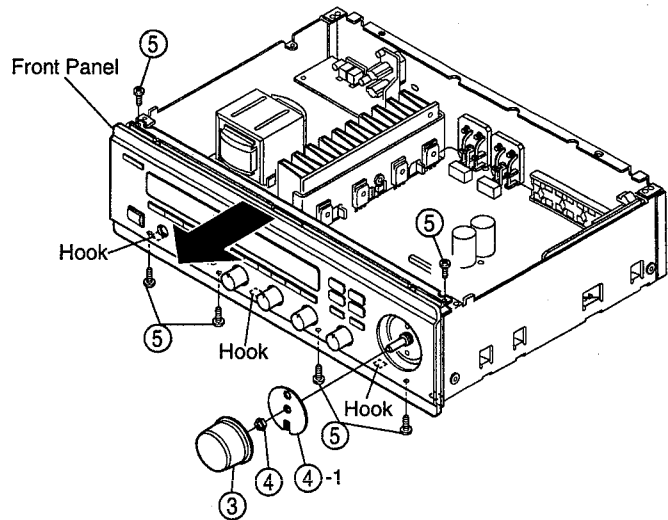

## 3. Rear Panel

- (1) Remove 2 screws ⑥ and 12 fixing screws ⑦.
- (2) Remove 4 screws ⑧.

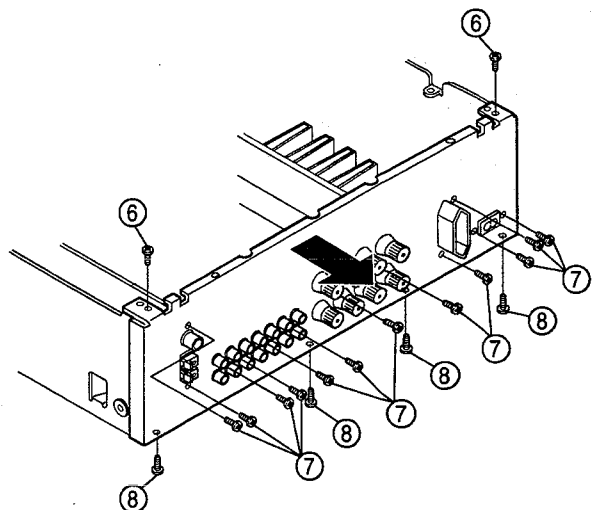

# SEMICONDUCTOR (FLD)

## ● FLD (14-BT39GK)

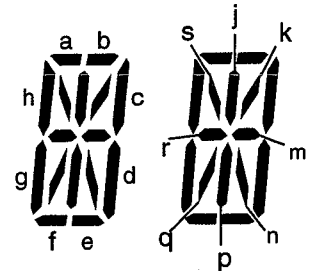
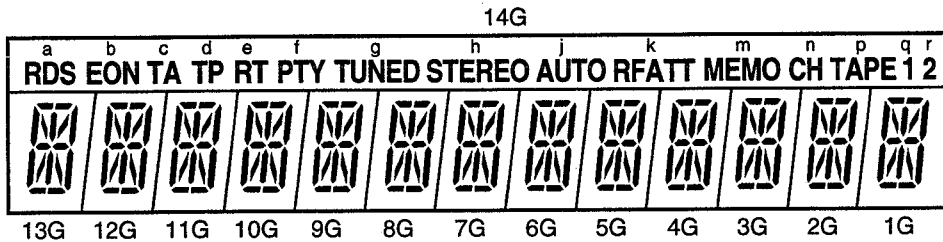
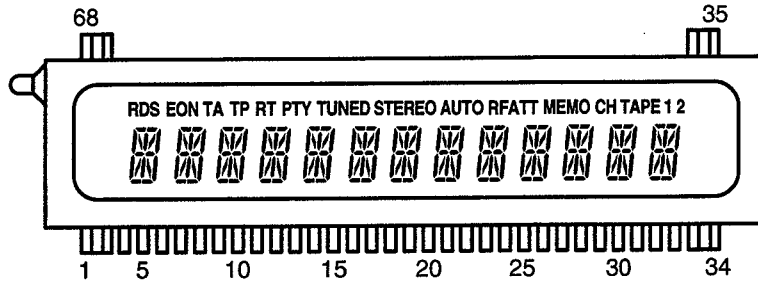

### TERMINAL CONNECTION

(UPPER)

TERMINAL No. ELECTRODE	68	67	66	65	64	63	62	61	60	59	58	57	56	55	54	53	52				
	F1	F1	NP	NP	NP	NP	NP	NP	NP	NP	NP	NP	NP	NP	NP	NP	NP				
TERMINAL No. ELECTRODE				51	50	49	48	47	46	45	44	43	42	41	40	39	38	37	36	35	
				NP	NP	NP	NP	NP	NP	NP	NP	NP	NP	NP	NP	NP	NP	NP	NP	F2	F2

(LOWER)

TERMINAL No. ELECTRODE				18	19	20	21	22	23	24	25	26	27	28	29	30	31	32	33	34
				P																
				a	14G	13G	12G	11G	10G	9G	8G	7G	6G	5G	4G	3G	2G	1G	F2	F2
TERMINAL No. ELECTRODE	1	2	3	4	5	6	7	8	9	10	11	12	13	14	15	16	17			
	F1	F1	P	P	P	P	P	P	P	P	P	P	P	P	P	P	P			
			s	r	q	p	n	m	k	j	h	g	f	e	d	c	b			

Notes: F: Filament G: Grid A: Anode NP: No Pin



# NOTE FOR PARTS LIST

- Part indicated with the mark "⊙" are not always in stock and possibly to take a long period of time for supplying, or in some case supplying of part may be refused.
  - When ordering of part, clearly indicate "1" and "I" (i) to avoid mis-supplying.
  - Ordering part without stating its part number can not be supplied.
  - Part indicated with the mark "★" is not illustrated in the exploded view.
  - Not including Carbon Film ±5%, 1/4W Type in the P.W.Board parts list. (Refer to the Schematic Diagram for those parts.)
- WARNING:**  
 Parts marked with this symbol  have critical characteristics.  
 Use ONLY replacement parts recommended by the manufacturer.

## ● Resistors

Ex.: **RN** **14K** **2E** **182** **G** **FR**  
 Type Shape Power Resist- Allowable Others  
 and per- ance error

RD : Carbon	2B : 1/8W	F : ±1%	P : Pulse-resistant type
RC : Composition	2E : 1/4W	G : ±2%	NL : Low noise type
RS : Metal oxide film	2H : 1/2W	J : ±5%	NB : Non-burning type
RW : Winding	3A : 1W	K : ±10%	FR : Fuse-resistor
RN : Metal film	3D : 2W	M : ±20%	F : Lead wire forming
RK : Metal mixture	3F : 3W		
	3H : 5W		

**\* Resistance**

**1 8 2** ⇒ 1800 ohm = 1.8 kohm  
 Indicates number of zeros after effective number.  
 2-digit effective number.

• Units: ohm

**1 R 2** ⇒ 1.2 ohm  
 1-digit effective number.  
 2-digit effective number, decimal point indicated by R.

• Units: ohm

## ● Capacitors

Ex.: **CE** **04W** **1H** **2R2** **M** **BP**  
 Type Shape Dielectric Capacity Allowable Others  
 and per- strength error

CE : Aluminum foil electrolytic	0J : 6.3V	F : ±1%	HS : High stability type
CA : Aluminum solid electrolytic	1A : 10V	G : ±2%	BP : Non-polar type
CS : Tantalum electrolytic	1C : 16V	J : ±5%	HR : Ripple-resistant type
CQ : Film	1E : 25V	K : ±10%	DL : For charge and discharge
CK : Ceramic	1V : 35V	M : ±20%	HF : For assuring high frequency
CC : Ceramic	1H : 50V	Z : +80%	U : UL part
CP : Oil	2A : 100V	-20%	C : CSA part
CM : Mica	2B : 125V	P : +100%	W : UL-CSA type
CF : Metallized	2C : 160V	-0%	F : Lead wire forming
CH : Metallized	2D : 200V	C : ±0.25pF	
	2E : 250V	D : ±0.5pF	
	2H : 500V	= : Others	
	2J : 630V		

**\* Capacity (electrolyte only)**

**2 2 2** ⇒ 2200µF  
 Indicates number of zeros after effective number.  
 2-digit effective number.

• Units: µF.

**2 R 2** ⇒ 2.2µF  
 1-digit effective number.  
 2-digit effective number, decimal point indicated by R.

• Units: µF.

**\* Capacity (except electrolyte)**

**2 2 2** ⇒ 2200pF=0.0022µF  
 (More than 2) Indicates number of zeros after effective number.  
 2-digit effective number.

• Units: µF.

**2 2 1** ⇒ 220pF  
 (0 or 1) Indicates number of zeros after effective number.  
 2-digit effective number.

• Units: pF.

• When the dielectric strength is indicated in AC, "AC" is included after the dielectric strength value.

# PARTS LIST OF P.W.B. UNIT

## 1U-2817G MAIN UNIT ASS'Y

Ref. No.	Part No.	Part Name	Remarks	Ref. No.	Part No.	Part Name	Remarks
<b>SEMICONDUCTORS GROUP</b>				<b>SEMICONDUCTORS GROUP</b>			
IC101	262 1227 008	IC LC7821		D405-410	276 0553 905	Diode 1SR35-200A	
IC301	263 0615 902	IC BA15218F		D411,412	276 0432 903	Diode 1SS270A	
IC401	263 1010 001	IC BA178M06		D451-453	276 0432 903	Diode 1SS270A	
IC701	263 1032 908	IC NJM2082MD		D651	276 0432 903	Diode 1SS270A	
IC801	262 1701 906	IC :SAA6579T		ZD101	276 0634 905	Zener diode MTZJ3.3A	
IC802	262 1929 908	IC LC7074M		ZD251,252	276 0637 902	Zener diode MTZJ6.2A	
TR251	274 0158 003	Transistor 2SD1763A(D)		ZD401	276 0634 905	Zener diode MTZJ3.3A	
TR252	272 0115 008	Transistor 2SB1186A(D)		ZD402	276 0633 906	Zener diode MTZJ6.8C	
TR253	273 0432 904	Transistor 2SC2389S(S/E)		ZD403	276 0632 907	Zener diode MTZJ27D	
TR254	271 0280 901	Transistor 2SA1038S(S/E)		ZD451-453	276 0635 904	Zener diode MTZJ7.5C	
TR255	273 0432 984	Transistor 2SC2389S(S/E)		SC451	279 0016 904	Thyristor SF0R1A42	
TR256	271 0280 901	Transistor 2SA1038S(S/E)		<b>RESISTORS GROUP</b>			
TR257	273 0432 904	Transistor 2SC2389S(S/E)		VR305,306	211 6093 909	Semi fixed resistor 6.8Kohm	V06PB682
TR301,302	269 0107 900	Transistor RN1241(A/B)	Built in resistor	R001,002	247 0018 905	Carbon chip 0ohm 1/10W	RM73B-0R0K
TR303,304	273 0235 923	Transistor 2SC1841(E/F)		R101-108	247 0014 967	Carbon chip 1Mohm 1/10W	RM73B-105J
TR305-308	271 0131 924	Transistor 2SA988(E/F)		R109-116	247 0006 962	Carbon chip 470ohm 1/10W	RM73B-471J
TR309,310	273 0235 923	Transistor 2SC1841(E/F)		R117	247 0014 925	Carbon chip 680kohm 1/10W	RM73B-684J
TR315,316	273 0198 905	Transistor 2SC1815(Y)		R131-134	247 0014 967	Carbon chip 1Mohm 1/10W	RM73B-105J
TR317,318	274 0060 900	Transistor 2SD667A(C)		R135-138	247 0006 962	Carbon chip 470ohm 1/10W	RM73B-471J
TR319,320	272 0053 908	Transistor 2SB647A(C)		△ R201,202	244 2052 931	Metal oxide film 390ohm 1W	RS14B3A391JNBS(S)
TR321,322	273 0389 002	Transistor 2SC3855(O/P/Y)		△ R250,260	241 2387 940	Carbon 4.7ohm 1/4W	RD14B2E4R7JNBS
TR323,324	271 0240 006	Transistor 2SA1491(O/P/Y)		R263	247 0009 985	Carbon chip 10kohm 1/10W	RM73B-103J
TR325,326	273 0235 923	Transistor 2SC1841(E/F)		R264	247 0012 927	Carbon chip 100kohm 1/10W	RM73B-104J
TR401	273 0384 900	Transistor 2SC2412K(S)	Built in resistor	R305,306	247 0012 969	Carbon chip 150kohm 1/10W	RM73B-154J
TR402	269 0048 904	Transistor DTC143EK		R307,308	247 0006 962	Carbon chip 470ohm 1/10W	RM73B-471J
TR403	273 0384 900	Transistor 2SC2412K(S)		R309,310	247 0009 914	Carbon chip 5.1kohm 1/10W	RM73B-512J
TR404	272 0131 901	Transistor 2SB1041(R)		△ R311,312	241 2379 932	Carbon 620ohm 1/4W	RD14B2E621JNBS
TR451	271 0131 924	Transistor 2SA988(E/F)		R323,324	247 0005 989	Carbon chip 220kohm 1/10W	RM73B-221J
TR452	273 0432 904	Transistor 2SC2389S(S/E)	Built in resistor	△ R329,330	241 2376 920	Carbon 220ohm 1/4W	RD14B2E221JNBS
TR453	269 0054 901	Transistor DTC144EK		△ R331-334	244 2043 982	Metal oxide film 0.22ohm 1W	RS14B3AR22JNBS(S)
TR454	273 0384 900	Transistor 2SC2412K(S)		R335,336	247 0013 984	Carbon chip 470kohm 1/10W	RM73B-474J
TR455	273 0388 906	Transistor 2SC1740S(E)		R351,352	247 0012 901	Carbon chip 82kohm 1/10W	RM73B-823J
TR456	271 0192 905	Transistor 2SA933S(S)		R353,354	247 0012 969	Carbon chip 150kohm 1/10W	RM73B-154J
TR457	273 0388 906	Transistor 2SC1740S(E)		R355,356	247 0004 922	Carbon chip 47ohm 1/10W	RM73B-470J
TR458,459	273 0432 904	Transistor 2SC2389S(S/E)		R357	247 0009 901	Carbon chip 4.7kohm 1/10W	RM73B-472J
TR460	273 0384 900	Transistor 2SC2412K(S)	Built in resistor	R358	247 0011 944	Carbon chip 47kohm 1/10W	RM73B-473J
TR471	269 0083 901	Transistor DTA114EK	Built in resistor	△ R361-364	244 2043 982	Metal oxide film 0.22ohm 1W	RS14B3AR22JNBS(S)
TR473	269 0054 901	Transistor DTC144EK	Built in resistor	△ R385,386	241 2379 932	Carbon 620ohm 1/4W	RD14B2E621JNBS
D251	276 0424 005	Bridge diode 4D4B42		△ R387-390	241 2377 989	Carbon 150ohm 1/4W	RD14B2E151JNBS
D252	276 0553 905	Diode 1SR35-200A		△ R391,392	244 2043 937	Metal oxide film 10ohm 1W	RS14B3A100JNBS(S)
D253,254	276 0432 903	Diode 1SS270A					
D303-306	276 0619 904	Diode 1S2471					
D307-312	276 0432 903	Diode 1SS270A					
D401,402	276 0432 903	Diode 1SS270A					
D403	276 0553 905	Diode 1SR35-200A					

Ref. No.	Part No.	Part Name	Remarks	Ref. No.	Part No.	Part Name	Remarks
R401	247 0013 900	Carbon chip 220kohm 1/10W	RM73B—224J	C327~330	254 4263 945	Electrolytic 1μF/100V	CE04W2A010M
R402	247 0009 985	Carbon chip 10kohm 1/10W	RM73B—103J	C331,332	254 4260 948	Electrolytic 1μF/50V	CE04W1H010M
R403	247 0009 901	Carbon chip 4.7kohm 1/10W	RM73B—472J	C333,334	254 4260 922	Electrolytic 0.33μF/50V	CE04W1HR33M
R404,405	247 0007 945	Carbon chip 1kohm 1/10W	RM73B—102J	C335,336	257 0004 961	Ceramic chip 100pF/50V	CC73SL1H101J
R406	247 0009 985	Carbon chip 10kohm 1/10W	RM73B—103J	C337,338	257 0002 992	Ceramic chip 20pF/50V	CC73SL1H200J
R407	247 0010 958	Carbon chip 20kohm 1/10W	RM73B—203J	C339,340	254 4254 925	Electrolytic 33μF/16V	CE04W1C330M
R408	247 0009 985	Carbon chip 10kohm 1/10W	RM73B—103J	C341,342	257 0004 961	Ceramic chip 100pF/50V	CC73SL1H101J
R409	247 0007 945	Carbon chip 1kohm 1/10W	RM73B—102J	Δ C353,354	256 1034 979	Metalized 0.1μF/50V	CF93A1H104J
R410	247 0009 901	Carbon chip 4.7kohm 1/10W	RM73B—472J	C355,356	255 1265 978	Film 0.022μF/50V	CQ93M1H223J(B)
Δ R411	244 2051 987	Metal oxide film 4.7ohm 1W	RS14B3A4R7JNBS(S)	C357	254 4260 948	Electrolytic 1μF/50V	CE04W1H010M
Δ R412	241 2377 947	Carbon 10kohm 1/4W	RD14B2E101JNBS	C358	253 9030 963	Ceramic 0.01μF/25V	CK45=1E103K
Δ R415	241 2387 908	Carbon 1ohm 1/4W	RD14B2E010JNBS	C359,360	254 4260 948	Electrolytic 1μF/50V	CE04W1H010M
Δ R451,452	244 2052 902	Metal oxide film 2.7kohm 1W	RS14B3A272JNBS(S)	C401	254 4258 905	Electrolytic 4.7μF/35V	CE04W1V4R7M
Δ R453	244 2051 990	Metal oxide film 4.7kohm 1W	RS14B3A472JNBS(S)	C402	257 0012 966	Ceramic chip 0.01μF/50V	CK73F1H103Z
R460	247 0011 944	Carbon chip 47kohm 1/10W	RM73B—473J	C403	254 4260 948	Electrolytic 1μF/50V	CE04W1H010M
Δ R465,466	244 2052 902	Metal oxide film 2.7kohm 1W	RS14B3A272JNBS(S)	C404,405	253 1181 904	Ceramic 0.01μF/50V	CK45F1H103Z
Δ R467	244 2050 991	Metal oxide film 6.8kohm 1W	RS14B3A682JNBS(S)	C406	259 0007 702	For back up 8200μF	SB CAP==822=C
R468	244 2052 957	Metal oxide film 5.6kohm 1W	RS14B3A562JNBS(S)	C407	254 4254 909	Electrolytic 10μF/16V	CE04W1C100M
R475	247 0010 929	Carbon chip 15kohm 1/10W	RM73B—153J	C408	254 4403 734	Electrolytic 4700μF/25V	CE04W1E472MC(SMG)
R701,702	247 0009 901	Carbon chip 4.7kohm 1/10W	RM73B—472J	C409	254 4261 921	Electrolytic 100μF/50V	CE04W1H101M
R703,704	247 0012 969	Carbon chip 150kohm 1/10W	RM73B—154J	C410	254 4260 948	Electrolytic 1μF/50V	CE04W1H010M
R705,706	247 0011 986	Carbon chip 68kohm 1/10W	RM73B—683J	C451	254 4260 980	Electrolytic 10μF/50V	CE04W1H100M
R707,708	247 0004 922	Carbon chip 47ohm 1/10W	RM73B—470J	C452	254 4254 925	Electrolytic 33μF/16V	CE04W1C330M
R709,710	247 0005 992	Carbon chip 240ohm 1/10W	RM73B—241J	C453	254 4250 945	Electrolytic 330μF/6.3V	CE04W0J331M
R711,712	247 0012 956	Carbon chip 130kohm 1/10W	RM73B—134J	C456	255 1265 936	Film 0.01μF/50V	CQ93M1H103J(B)
R713,714	247 0009 998	Carbon chip 11kohm 1/10W	RM73B—113J	C459,460	253 1151 905	Ceramic 4700pF/500V	CK45E2H472P
R715,716	247 0003 949	Carbon chip 22ohm 1/10W	RM73B—220J	Δ C461	256 1042 903	Metalized 0.1μF/250V	CF93A2E104K
R717,718	247 0005 905	Carbon chip 100ohm 1/10W	RM73B—101J	C462	254 4254 938	Electrolytic 47μF/16V	CE04W1C470M
R719,720	247 0012 927	Carbon chip 100kohm 1/10W	RM73B—104J	C549	254 4252 927	Electrolytic 47μF/10V	CE04W1A470M
<b>CAPACITORS GROUP</b>				C582	253 4538 949	Ceramic 100pF/50V	CK45SL1H101J
C101~108	257 0004 903	Ceramic chip 56pF/50V	CC73SL1H560J	C701,702	257 0003 988	Ceramic chip 47pF/50V	CC73SL1H470J
C109,110	253 1179 945	Ceramic 220pF/50V	CK45B1H221KT	C703,704	257 0005 944	Ceramic chip 220pF/50V	CC73SL1H221J
C111	257 0002 921	Ceramic chip 10pF/50V	CC73SL1H100D	C705,706	254 4254 909	Electrolytic 10μF/16V	CE04W1C100M
C112,113	257 0012 982	Ceramic chip 0.022μF/50V	CK73F1H223Z	C709,710	254 4250 929	Electrolytic 100μF/6.3V	CE04W0J101M
C124,125	257 0012 982	Ceramic chip 0.022μF/50V	CK73F1H223Z	C711,712	255 4199 999	Film 0.024μF/50V	CQ92M1H243J(MRZ)
C127	257 0012 982	Ceramic chip 0.022μF/50V	CK73F1H223Z	C713,714	255 1265 907	Film 6800pF/50V	CQ93M1H682J(B)
C131~134	257 0004 903	Ceramic chip 56pF/50V	CC73SL1H560J	C715,716	254 4254 909	Electrolytic 10μF/16V	CE04W1C100M
C201~204	255 1265 907	Film 6800pF/50V	CQ93M1H682J(B)	C717,718	253 1181 904	Ceramic 0.01μF/50V	CK45F1H103Z
C205,206	257 0006 985	Ceramic chip 820pF/50V	CC73SL1H821J	C724	254 4260 948	Electrolytic 1μF/50V	CE04W1H010M
C251~254	254 4258 918	Electrolytic 10μF/35V	CE04W1V100M	C725	257 0012 982	Ceramic chip 0.022μF/50V	CK73F1H223Z
Δ C257,258	254 6201 002	Electrolytic 7200μF/63V	CE04W==722MC(DL)	C801,802	257 0016 962	Ceramic chip 27pF/50V	CC73CH1H270J
C259	253 1181 904	Ceramic 0.01μF/50V	CK45F1H103Z	C803~805	254 4250 916	Electrolytic 47μF/6.3V	CE04W0J470M
C307,308	257 0006 927	Ceramic chip 470pF/50V	CC73SL1H471J	C807,808	257 0003 933	Ceramic chip 30pF/50V	CC73SL1H300J
C309,310	255 1265 936	Film 0.01 μF/50V	CQ93M1H103J(B)	C809	257 0012 966	Ceramic chip 0.01μF/50V	CK73F1H103Z
C311~314	253 4536 909	Ceramic 10pF/50V	CC45SL1H100D	C810	254 4250 916	Electrolytic 47μF/6.3V	CE04W0J470M
C321,322	255 1265 936	Film 0.01 μF/50V	CQ93M1H103J(B)	C811	257 0006 943	Ceramic chip 560pF/50V	CC73SL1H561J
C323,324	254 4260 948	Electrolytic 1μF/50V	CE04W1H010M				
C325,326	255 1265 936	Film 0.01μF/50V	CQ93M1H103J(B)				

1U-2818 TUNER UNIT ASS'Y

Ref. No.	Part No.	Part Name	Remarks
<b>OTHERS PARTS GROUP</b>			
△ AC401	203 3951 004	1P AC outlet	
CB29D	205 0990 045	29P FFC connector base	
CB6A,6C	205 0343 061	6P connector base (KR-PH)	
CB8A	205 0343 087	8P connector base (KR-PH)	
CB8B,8C	205 0806 090	8P connector base (9115)	
△ CN2A	203 2349 009	2P inlet	
CN2B	205 0581 085	2P VH connector base	Blue
CN2C	203 2377 000	2P DA-DA connector cord	
CN3A	205 0581 001	2P VH connector base	White
CN7A	205 0653 078	7P VH connector base	
△ F401	206 1075 030	Fuse (2.0A)	
△ F402	206 1075 043	Fuse (2.5A)	
	513 2585 074	Fuse label	for F402
	202 0040 909	Fuse clip	for F401, F402
L391,392	235 0104 007	Inductor(1MHz)	
L701,702	235 9003 002	FTZ choke coil	
RL451,452	214 0167 005	Relay(G5Z-2A)	
RL453	214 0127 003	Relay(RY-12W)	
TH451	279 0034 067	Posistor	PTH9M04BB222TS2F333
TP001,002	205 0190 036	3P NH Connector base	TEST POINT
XL601	399 0178 007	Crystal	4.332MHz
XT801	399 0041 901	Resonator	CSA4.00MG
	205 0484 001	8P speaker terminal	
	203 0475 056	1P contact Ass'y	D-D
JK101	204 8485 012	4P pin jack(S-GND) AU	
JK102	204 8486 011	6P pin jack(S-GND) AU	
JK103	204 8485 012	4P pin jack(S-GND) AU	
	461 0415 007	Rubber sheet	for C582

Ref. No.	Part No.	Part Name	Remarks
<b>SEMICONDUCTORS GROUP</b>			
IC501	263 0891 001	IC LA1265(S)	
IC502	263 0439 007	IC LA3401	
IC503	262 2349 901	IC LM7001JUM	
IC504	263 0794 001	IC NJM78M12FA(S)	
TR501	275 0074 902	Transistor 2SK211(Y/GR)	
TR502	273 0438 908	Transistor 2SC2413K (Q)	
TR503	269 0157 905	Transistor DTB123EK	Built in resistor
TR504	269 0083 901	Transistor DTA114EK	Built in resistor
TR505,506	269 0054 901	Transistor DTC144EK	Built in resistor
TR507	271 0286 905	Transistor 2SA1515S(R)	
TR508	275 0075 901	Transistor 2SK209(Y/GR)	
TR509	273 0403 904	Transistor 2SC2712(Y/GR)	
D501	276 0559 909	Diode DAP202K	
<b>RESISTORS GROUP (Not included carbon film ±5% 1/4W)</b>			
R001-016	247 0018 905	Chip 0ohm 1/10W	RM73B-0R0K
R501	247 0004 906	Chip 39ohm 1/10W	RM73B-390J
R502	247 0006 946	Chip 390ohm 1/10W	RM73B-391J
R503	247 0009 985	Chip 10kohm 1/10W	RM73B-103J
R504	247 0009 927	Chip 5.6kohm 1/10W	RM73B-562J
R505	247 0006 920	Chip 330ohm 1/10W	RM73B-331J
R506	247 0009 901	Chip 4.7kohm 1/10W	RM73B-472J
R507	247 0005 989	Chip 220ohm 1/10W	RM73B-221J
R508,509	247 0006 920	Chip 330ohm 1/10W	RM73B-331J
R510	247 0006 988	Chip 560ohm 1/10W	RM73B-561J
R511	247 0012 927	Chip 100kohm 1/10W	RM73B-104J
R512	247 0009 914	Chip 5.1kohm 1/10W	RM73B-512J
R513	247 0005 905	Chip 100ohm 1/10W	RM73B-101J
R514	247 0008 986	Chip 3.9kohm 1/10W	RM73B-392J
R515	247 0006 946	Chip 390ohm 1/10W	RM73B-391J
R516	247 0005 947	Chip 150ohm 1/0W	RM73B-151J
R517	247 0009 985	Chip 10kohm 1/10W	RM73B-103J
R518	247 0018 905	Chip 0ohm 1/10W	RM73B-0R0K
R519	247 0009 901	Chip 4.7kohm 1/10W	RM73B-472J
R520	247 0004 980	Chip 82ohm 1/10W	RM73B-820J
R521	247 0008 944	Chip 2.7kohm 1/10W	RM73B-272J
R522	247 0011 902	Chip 33kohm 1/10W	RM73B-333J
R523-525	247 0009 985	Chip 10kohm 1/10W	RM73B-103J
R526	247 0008 957	Chip 3kohm 1/10W	RM73B-302J
R527	247 0011 986	Chip 68kohm 1/10W	RM73B-683J
R528	247 0009 943	Chip 6.8kohm 1/10W	RM73B-682J
R529	247 0008 960	Chip 3.3kohm 1/10W	RM73B-332J
R530	247 0012 927	Chip 100kohm 1/10W	RM73B-104J
R532	247 0009 985	Chip 10kohm 1/10W	RM73B-103J
R533	247 0007 945	Chip 1kohm 1/10W	RM73B-102J
R534	247 0011 915	Chip 36kohm 1/10W	RM73B-363J
R535	247 0010 974	Chip 24kohm 1/10W	RM73B-243J
R536	247 0012 985	Chip 180kohm 1/10W	RM73B-184J

Ref. No.	Part No.	Part Name	Remarks
R537	247 0012 998	Chip 200kohm 1/10W	RM73B--204J
R538	247 0012 985	Chip 180kohm 1/10W	RM73B--184J
R539	247 0012 998	Chip 200kohm 1/10W	RM73B--204J
R540,541	247 0008 902	Chip 1.8kohm 1/10W	RM73B--182J
R542,543	247 0009 901	Chip 4.7kohm 1/10W	RM73B--472J
R544	247 1007 986	Chip 1.5kohm 1/8W	RM73B2B152J
R545	247 0009 985	Chip 10kohm 1/10W	RM73B--103J
R546	247 0012 927	Chip 100kohm 1/10W	RM73B--104J
CAPACITORS GROUP			
C501-506	257 0012 966	Chip(Ceramic) 0.01µF/50V	CK73F1H103Z
C507	257 0002 947	Chip(Ceramic) 12pF/50V	CC73SL1H120J
C508	254 4254 909	Electrolytic 10µF/16V	CE04W1C100M
C509	257 0004 961	Chip(Ceramic) 100pF/50V	CC73SL1H101J
C510	257 0012 966	Chip(Ceramic) 0.01µF/50V	CK73F1H103Z
C511	254 4260 906	Electrolytic 0.1µF/50V	CE04W1H0R1M
C513	254 3056 917	Electrolytic 1µF/50V (Non-polar)	CE04D1H010MBP
C514	257 0012 982	Chip(Ceramic) 0.022µF/50V	CK73F1H223Z
C515,516	257 0002 976	Chip(Ceramic) 16pF/50V	CC73SL1H160J
C517	254 4254 938	Electrolytic 47µF/16V	CE04W1C470M
C518,519	257 0012 966	Chip(Ceramic) 0.01µF/50V	CK73F1H103Z
C520	254 4260 922	Electrolytic 0.33µF/50V	CE04W1HR33M
C521	257 0012 966	Chip(Ceramic) 0.01µF/50V	CK73F1H103Z
C522	254 4256 936	Electrolytic 47µF/25V	CE04W1E470M
C523	254 4260 948	Electrolytic 1µF/50V	CE04W1H010M
C524	254 4260 964	Electrolytic 3.3µF/50V	CE04W1H3R3M
C525	257 0012 982	Chip(Ceramic) 0.022µF/50V	CK73F1H223Z
C526	257 0012 966	Chip(Ceramic) 0.01µF/50V	CK73F1H103Z
C527	254 4260 948	Electrolytic 1µF/50V	CE04W1H010M
C528	254 4254 909	Electrolytic 10µF/16V	CE04W1C100M
C529	257 1013 951	Chip(Ceramic) 0.047µF/25V	CK73F1E473K
C530	254 4254 912	Electrolytic 22µF/16V	CE04W1C220M
C531	257 0004 961	Chip(Ceramic) 100pF/50V	CC73SL1H101J
C532	254 4260 948	Electrolytic 1µF/50V	CE04W1H010M
C533	254 4260 919	Electrolytic 0.22µF/50V	CE04W1HR22M
C534	254 4260 948	Electrolytic 1µF/50V	CE04W1H010M
C535,536	257 0012 966	Chip(Ceramic) 0.01µF/50V	CK73F1H103Z
C537	254 4254 912	Electrolytic 22µF/16V	CE04W1C220M
C538	254 4254 938	Electrolytic 47µF/16V	CE04W1C470M
C539,540	257 0005 960	Chip(Ceramic) 270pF/50V	CC73SL1H271J
C541	254 4260 951	Electrolytic 2.2µF/50V	CE04W1H2R2M
C545	253 0012 966	Chip(Ceramic) 0.01µF/50V	CK73F1H103Z
C548	254 4260 951	Electrolytic 2.2µF/50V	CE04W1H2R2M
C550,551	254 4260 948	Electrolytic 1µF/50V	CE04W1H010M
C553,554	257 0012 966	Chip(Ceramic) 0.01µF/50V	CK73F1H103Z
C555	256 1058 939	Metalized 0.047µF/50V	CF93A1H473J(JL)
C561	257 0012 966	Chip(Ceramic) 0.01µF/50V	CK73F1H103Z
C581	253 1181 904	Ceramic 0.01µF/50V	CK45F1H103Z
C583	253 4538 046	Ceramic 100pF/50V	CC45SL1H101J

Ref. No.	Part No.	Part Name	Remarks
OTHERS PARTS GROUP			
CF501,502	261 0064 007	Ceramic filter	SFT10.7MS2
CF504	261 0101 009	Ceramic filter	BFU450C4N
CN8B,8C	205 0805 091	8P connector socket	
FE501	216 0065 006	Front end	
T501	231 1913 004	MW antenna OSC coil	
T502	231 2099 008	FM DET trans	
T503	231 3904 008	AM IFT	
T504	232 9010 009	Antibirdie filter	
T505,506	232 0085 004	LPF	
XL502	261 0103 007	Resonator	CSB456F11
XL503	399 0075 003	Crystal	7.2MHz
	205 0847 004	3P antenna terminal(PAL/F)	
	001 0036 064	VINYL wire	with R581
	461 0415 007	Rubber sheet	for R581
	205 0003 107	3T LUG	with C382
	415 0309 026	P.V.C. Tube (φ1, ℓ=20)	for C382

1U-3204 DISPLAY UNIT ASS'Y

Ref. No.	Part No.	Part Name	Remarks
SEMICONDUCTORS GROUP			
IC601	262 2249 001	IC TMP87CM71F-6348	
IC602	263 0905 900	IC BA6208F	
ZD651	276 0654 901	Zener diode DTZ8.2B	
FL401	393 8020 007	VFD(14-BT-39GK)	
RESISTORS GROUP			
R301,302	247 0011 928	Carbon chip 39kohm 1/10W	RM73B--393J
R303,304	247 0009 943	Carbon chip 6.8kohm 1/10W	RM73B--682J
R361,362	247 0011 973	Carbon chip 62kohm 1/10W	RM73B--623J
R363,364	247 0009 998	Carbon chip 11kohm 1/10W	RM73B--113J
R365,366	247 0008 931	Carbon chip 2.4kohm 1/10W	RM73B--242J
R367,368	247 0013 984	Carbon chip 470kohm 1/10W	RM73B--474J
R369,370	247 0010 945	Carbon chip 18kohm 1/10W	RM73B--183J
R371,372	247 0009 943	Carbon chip 6.8kohm 1/10W	RM73B--682J
R373,374	247 0006 917	Carbon chip 300ohm 1/10W	RM73B--301J
R375,376	247 0011 944	Carbon chip 47kohm 1/10W	RM73B--473J
R379,380	247 0009 901	Carbon chip 4.7kohm 1/10W	RM73B--472J
R651	247 1009 900	Carbon chip 4.7kohm 1/8W	RM73B2B472J
R652-657	247 0009 985	Carbon chip 10kohm 1/10W	RM73B--103J
R665	247 0007 945	Carbon chip 1kohm 1/10W	RM73B--102J
R666	247 0005 976	Carbon chip 200ohm 1/10W	RM73B--201J
R667	247 0006 917	Carbon chip 300ohm 1/10W	RM73B--301J
R668	247 0007 945	Carbon chip 1kohm 1/10W	RM73B--102J
R669	247 0005 976	Carbon chip 200ohm 1/10W	RM73B--201J
R670	247 0006 917	Carbon chip 300ohm 1/10W	RM73B--301J
R671	247 0007 945	Carbon chip 1kohm 1/10W	RM73B--102J
R672	247 0005 976	Carbon chip 200ohm 1/10W	RM73B--201J
R673	247 0006 917	Carbon chip 300ohm 1/10W	RM73B--301J
R674	247 0006 975	Carbon chip 510ohm 1/10W	RM73B--511J
R675,676	247 0007 945	Carbon chip 1kohm 1/10W	RM73B--102J
R677	247 0005 976	Carbon chip 200ohm 1/10W	RM73B--201J
R678	247 0006 917	Carbon chip 300ohm 1/10W	RM73B--301J
R679	247 0006 975	Carbon chip 510ohm 1/10W	RM73B--511J
R680	247 0007 945	Carbon chip 1kohm 1/10W	RM73B--102J
R681-683	247 0009 985	Carbon chip 10kohm 1/10W	RM73B--103J
R685	247 0008 957	Carbon chip 3kohm 1/10W	RM73B--302J
VR301	211 0841 018	Variable resistor 100kohm	V14P22FW104K
VR302	211 0831 002	Variable resistor 100kohm	V1620V25F=104R(MG)
VR303	211 0842 017	Variable resistor 250kohm	V14P22FC254K
VR304	211 0843 016	Variable resistor 50kohm	V14P22FC503K
VR307	211 9131 004	Variable resistor 100kohm	V14P22FB104K

Ref. No.	Part No.	Part Name	Remarks	Q'ty
CAPACITORS GROUP				
C300	257 0012 966	Ceramic chip 0.01 µF/50V	CK73F1H103Z	
C301,302	257 0006 943	Ceramic chip 560 pF/50V	CC73SL1H561J	
C303,304	255 1265 978	Mylar film 0.022 µF/50V	CQ93M1H223J(B)	
C361,362	257 0004 961	Ceramic chip 100 pF/50V	CC73SL1H101J	
C363,364	255 1265 981	Mylar film 0.027 µF/50V	CQ93M1H273J(B)	
C365,366	256 1058 984	Metalized 0.12 µF/50V	CF93A1H124J(JL)	
C367,368	255 1264 924	Mylar film 1500 pF/50V	CQ93M1H152J(B)	
C369,370	255 1265 936	Mylar film 0.01 µF/50V	CQ93M1H103J(B)	
C372	257 0012 966	Ceramic chip 0.01 µF/50V	CK73F1H103Z	
△ C411	253 8014 702	Ceramic 0.01 µF/400V(AC)	CK45F2GAC103MC	
C651	257 0012 966	Ceramic chip 0.01 µF/50V	CK73F1H103Z	
C652	254 4300 963	Electrolytic 100 µF/6.3V	CE04W0J101M(SRE)	
C653	257 0012 966	Ceramic chip 0.01 µF/50V	CK73F1H103Z	
C655	254 4299 964	Electrolytic 47 µF/16V	CE04W1C470M(SRE)	
C657	257 0012 982	Ceramic chip 0.022 µF/50V	CK73F1H223Z	
C666	257 0004 961	Ceramic chip 100 pF/50V	CC73SL1H101J	
OTHER PARTS GROUP				
CB2B	205 0581 085	2P VH connector base	Blue	1
CB8D	205 0919 026	8P JQ sockt (Side)		1
CB10A	205 0375 000	10P connector base (KR-PH)		1
CN6A,6C	205 0355 062	6P KR connector base (L)		2
CN8A	205 0355 088	8P KR connector base (L)		1
CN8D	205 0408 045	8P JQ connector		1
CN10A	205 0480 005	10P KR connector base (L)		1
CN29D	205 0990 045	29P FFC connector base		1
G003	203 0418 071	1P SIN cord Ass'y		1
JK201	204 8341 004	Headphone jack		1
RM601	499 2023 007	Remocon sensor	SBX1810-52	1
SW601-603	212 5604 910	Tact switch		3
SW605-617	212 5604 910	Tact switch		13
△ SW401	212 1101 006	Power switch (TV-5)		1
SW302,303	212 1140 009	Push switch (ESB6440)		2
XL651	399 0261 901	Resonator	DCRH4.00M	1
	461 0877 014	Rubber sheet	for FL401	2
	415 0299 000	Condenser cover	for C411	1
	203 5103 019	3P SAN-SAN connector cord	CB3C-CN3C	1
	414 0740 006	Shield plate		1



PRINTED WIRING BOARDS

1

2

3

4

5

6

7

8

1U-2817-1 MAIN UNIT ASS'Y

1U-2817-2

A

B

C

D

E

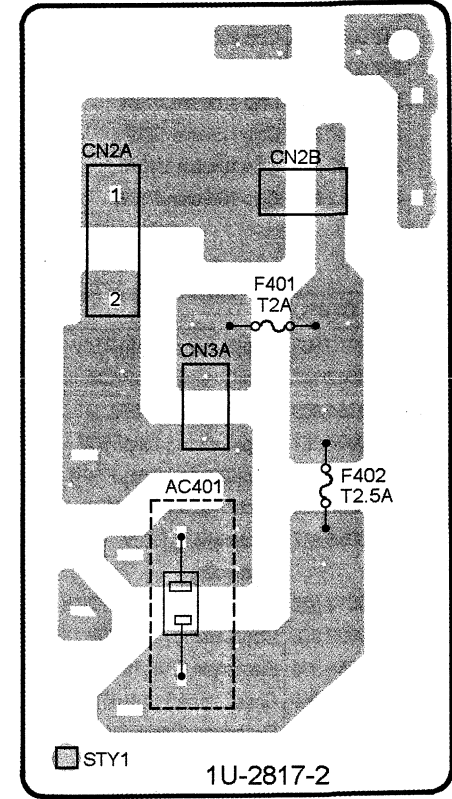
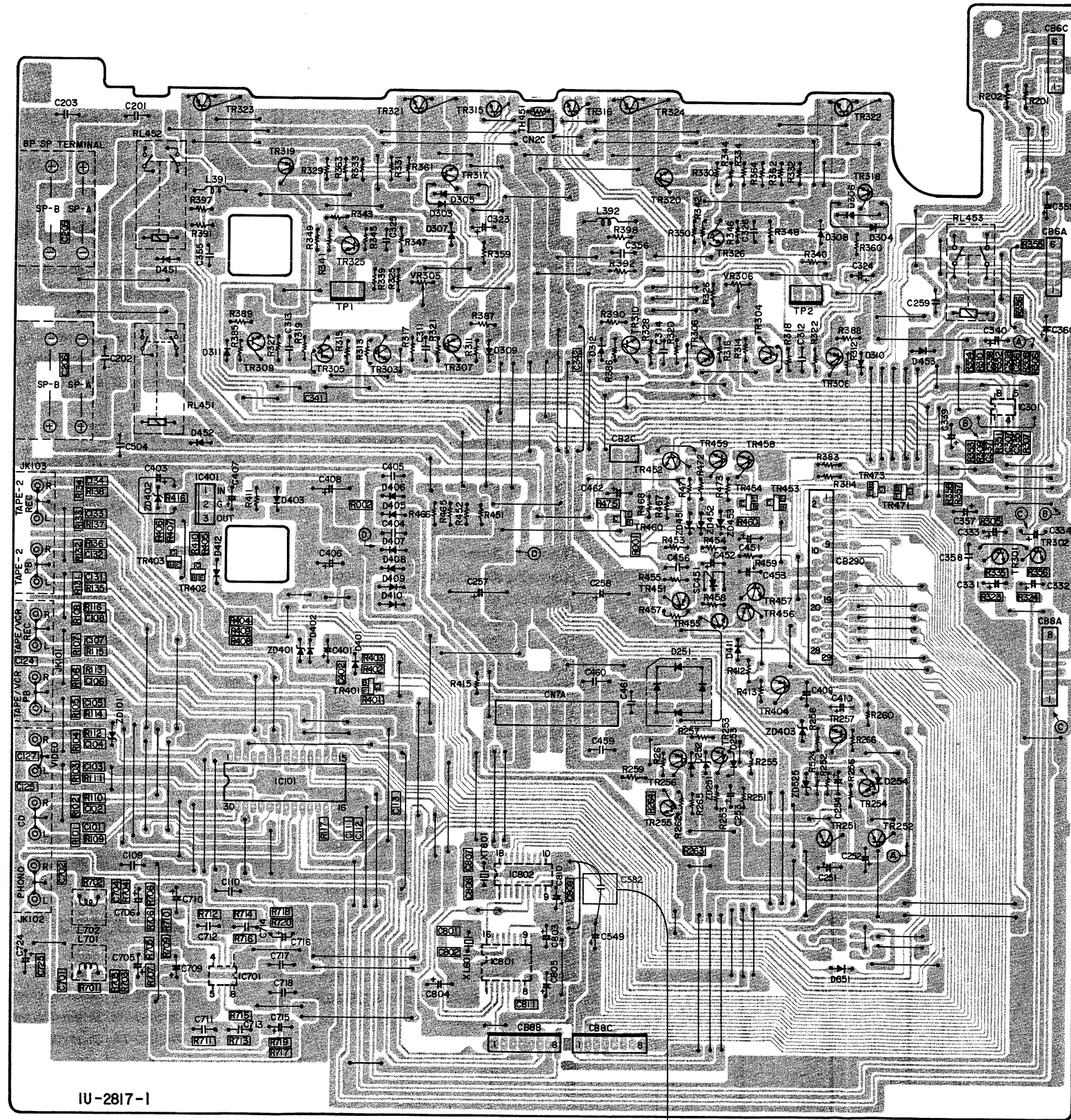

RUBBER SHEET





# EXPLODED VIEW

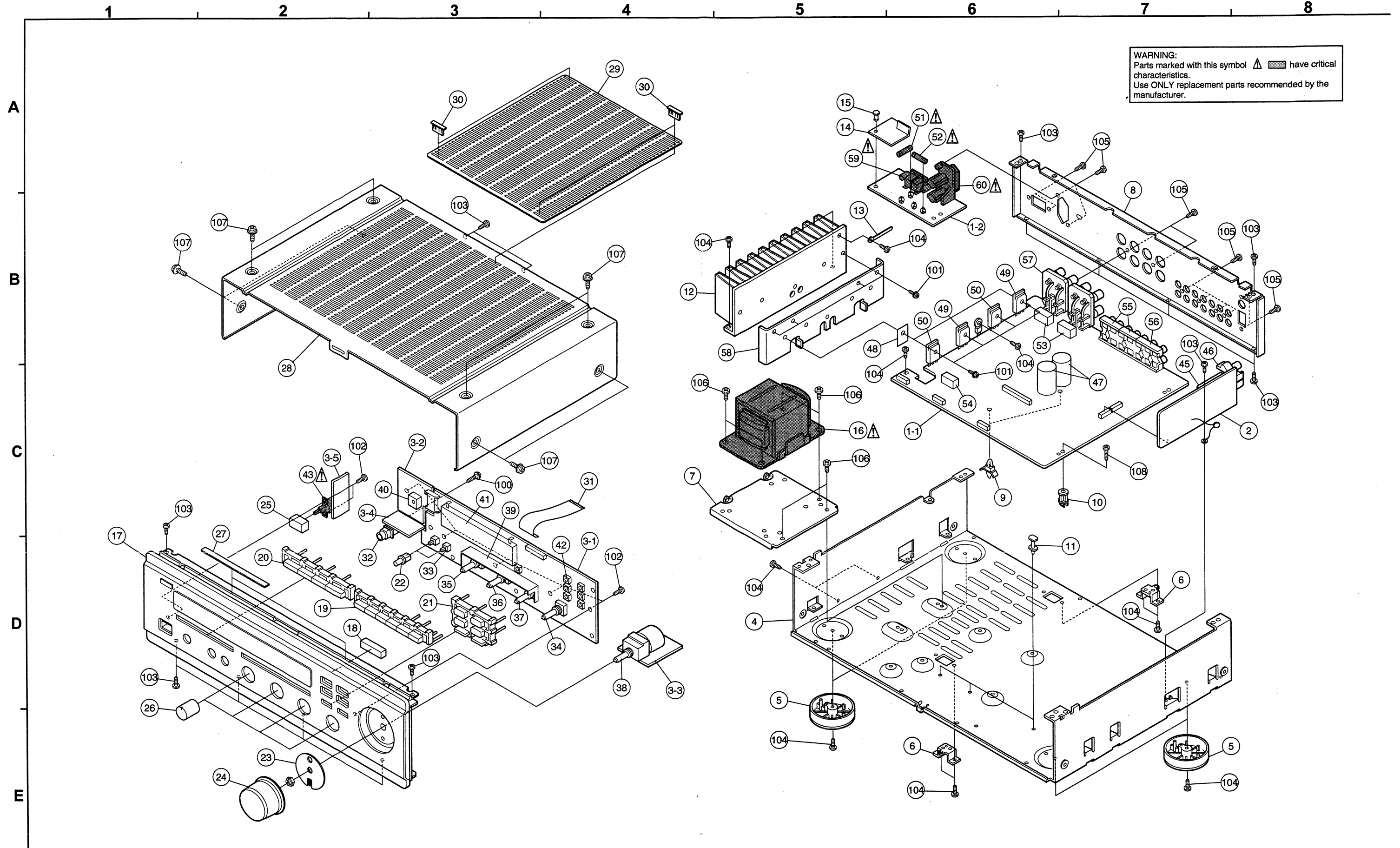



**PARTS LIST OF EXPLODED VIEW**

Ref. No.	Part No.	Part Name	Remarks	Q'ty	Ref. No.	Part No.	Part Name	Remarks	Q'ty
1	1U-2817G	Main unit Ass'y		1	36	211 0843 016	Variable resistor 50kohm	VR304	1
1-1		Main unit			37	211 0841 018	Variable resistor 100kohm	VR301	1
1-2		Power unit			38	211 0831 002	Variable resistor 100kohm	VR302	1
2	1U-2818	Tuner unit Ass'y		1	39	414 0740 006	Shield plate		1
3	1U-3204	Display unit Ass'y		1	40	499 2023 007	Remocon sensor	SBX1810-52	1
3-1		Display unit		1	41	393 8020 007	VFD(14-BT-39GK)	FL401	1
3-2		Display B unit			42	212 5604 910	Tact switch		16
3-3		Volume unit			Δ 43	212 1101 006	Power switch (TV-5)	SW401	1
3-4		H/P unit			45	216 0065 006	Front end		1
3-5		Power SW unit			46	205 0847 004	3P antenna terminal(PAL/F)		1
4	411 1402 108	Chassis		1	47	254 6201 002	Electrolytic 7200μF/63V	C257,258	2
5	104 0194 205	Foot Ass'y		4	48	415 0234 007	Insulating sheet		4
6	412 4504 006	Radiator bracket		2	49	271 0240 006	Transistor 2SA1491(O/P/Y)(Z)	TR323,324	2
7	412 4340 202	Trans bracket		1	50	273 0389 002	Transistor 2SC3855(O/P/Y)(Z)	TR321,322	2
8	105 1312 102	Back panel		1	Δ 51	206 1075 030	Fuse(2.0A)	F401	1
9	449 0033 036	Locking card spacer		2	Δ 52	206 1075 043	Fuse(2.5A)	F402	1
10	412 3548 005	P.W.B catcher		1	53	214 0167 005	Relay(G5Z-2A)	RL451,452	2
11	412 2814 028	Card spacer (L=10)		4	54	214 0127 003	Relay(RY-12W)	RL453	1
12	417 0529 006	Power radiator		1	55	204 8485 012	4P pin jack (S-GND)AU		2
13	445 0048 003	Cord holder(L=76)		1	56	204 8486 011	6P pin jack (S-GND)AU		1
14	415 0824 006	Insulating sheet		1	57	205 0484 001	8P speaker terminal		1
15	477 0096 007	Push rivet		1	58	417 0520 102	Sub radiator		1
16	233 6194 002	Power trans.		1	Δ 59	203 2349 009	2P inlet	CN2A	1
17	144 2660 104	Front panel Ass'y	Black model	1	Δ 60	203 3961 004	1P AC outlet	AC401	1
17	144 2660 117	Front panel Ass'y	Gold model	1	★ 61	445 8004 007	Wire clammer		1
18	461 1034 005	Rubber sheet		1	Δ ★ 62	203 5132 093	3P VH connector cord		1
19	113 9325 008	Series knob (A)	Black model	1	★ 63	204 0389 019	6P PH connector cord		2
19	113 9325 024	Series knob (A)	Gold model	1	★ 64	204 2661 078	8P PH-PH connector cord		1
20	113 9326 007	Series knob (B)	Black model	1	★ 65	204 2572 031	10P PH connector cord		1
20	113 9326 023	Series knob (B)	Gold model	1	★ 66	513 1642 002	NO. sheet		1
21	113 9324 274	Function knob	Black model	1					
21	113 9324 261	Function knob	Gold model	1					
22	113 9323 000	Push knob (SP)	Black model	2					
22	113 9323 039	Push knob (SP)	Gold model	2					
23	412 9521 013	Volume plate		1					
24	112 9123 139	Knob Ass'y(M)	Black model	1					
24	112 9123 126	Knob Ass'y(M)	Gold model	1					
25	113 9213 000	Power knob (P) Ass'y	Black model	1					
25	113 9213 084	Power knob (P) Ass'y	Gold model	1					
26	112 0739 001	Knob (MARU)	Black model	4					
26	112 0739 027	Knob (MARU)	Gold model	4					
27	461 0501 005	Rubber sheet		2					
28	102 0601 006	Top cover	Black model	1				Black model	8
28	102 0601 019	Top cover	Gold model	1				Gold model	8
29	414 0880 005	Safety cover	Black model	1					1
29	414 0880 018	Safety cover	Gold model	1					
30	449 0139 105	Cover holder		4					
31	009 0109 021	29P FFC cable		1					
32	204 8341 004	Headphone jack	JK201	1					
33	212 1140 009	Push switch (ESB6440)	SW302,303	2					
34	211 9131 004	Variable resistor 100kohm	VR307	1					
35	211 0842 017	Variable resistor 250kohm	VR303	1					
<b>SCREWS &amp; NUTS</b>									
					100	477 0262 006	Special screw		1
					101	473 8007 009	Cup screw 3 × 12		8
					102	473 7500 044	Screw 3 × 8 CBTS(P)-B		7
					103	473 7015 018	Screw 3 × 8 CBTS(S)-B		14
					104	473 7002 018	Screw 3 × 8 CBTS(S)-Z		16
					105	473 8057 004	Screw 3 × 10 CBTS(B)-B		12
					106	473 7004 016	Screw 4 × 6 CBTS(S)-Z		6
					107	477 0263 005	3P. swelling screw	Black model	8
					107	477 0263 018	3P. swelling screw	Gold model	8
					108	473 7501 027	Screw 3 × 16 CBTS (P)-Z		1

Ref. No.	Part No.	Part Name	Remarks	Q'ty
<b>PACKING &amp; ACCESSORIES (Not included EXPLODED VIEW.)</b>				
201	505 0283 018	Envelope		1
202	511 3419 004	Instruction manual(8)		1
203	515 0671 724	S.S. list (EX)		1
204	231 1914 003	Loop antenna		1
205	395 0023 008	FM antenna Ass'y		1
206	399 0242 001	Remote control unit	RC-174	1
Δ 207	206 2108 003	AC connector with plug		1
208	505 0131 050	Cabinet cover		1
209	503 1281 000	Cushion		2
210	501 2044 004	Carton case		1
211	517 1400 000	E2 POS label	Black model	1
211	517 1400 013	E2 POS label	Gold model	1
212	513 9111 001	Color label (gold)	Gold model	2
213	513 1389 006	Control card		1

**SCHEMATIC DIAGRAMS (1/2)**

1

2

3

4

5

6

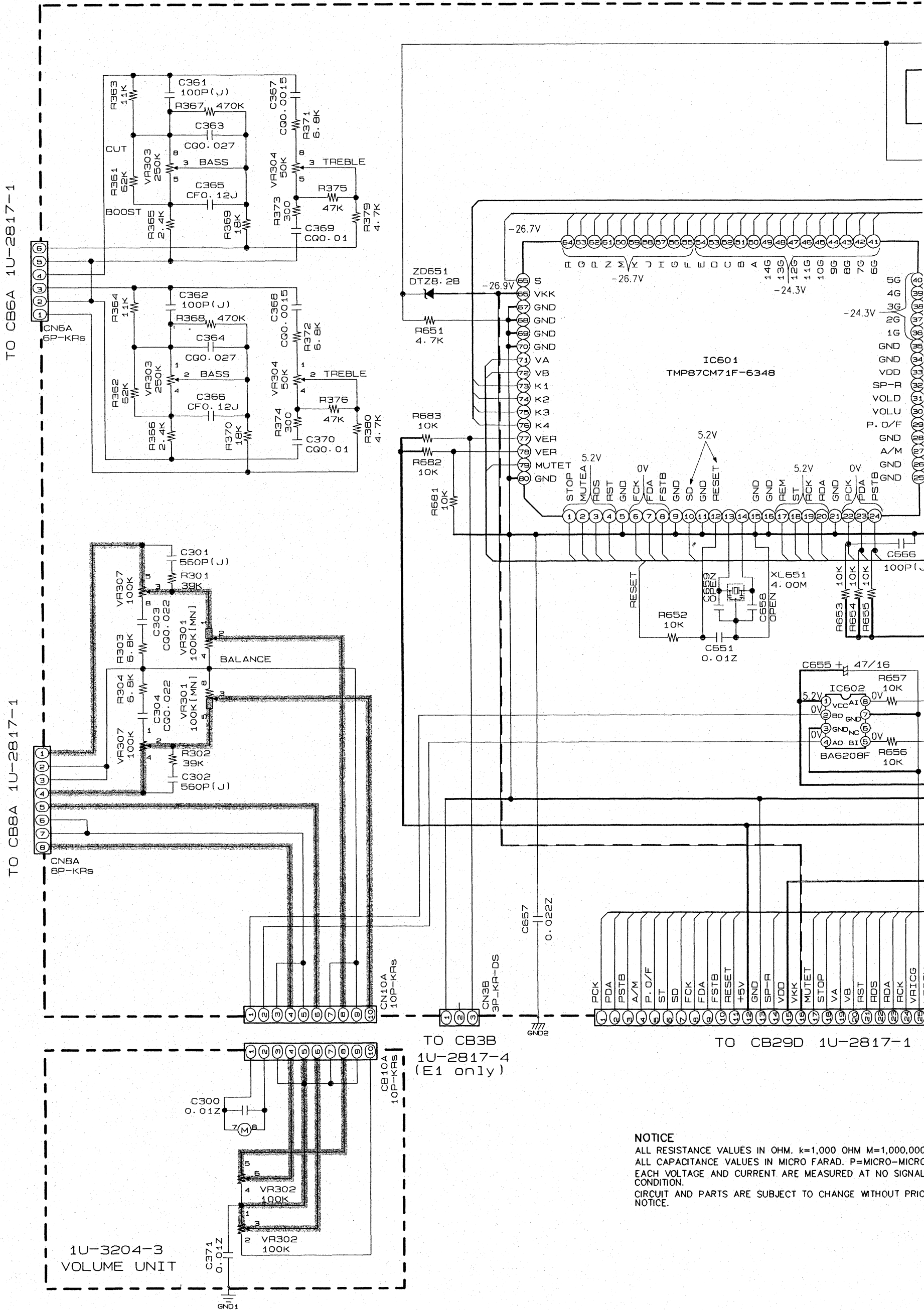

**NOTICE**  
 ALL RESISTANCE VALUES IN OHM. k=1,000 OHM M=1,000,000  
 ALL CAPACITANCE VALUES IN MICRO FARAD. P=MICRO-MICRO  
 EACH VOLTAGE AND CURRENT ARE MEASURED AT NO SIGNAL  
 CONDITION.  
 CIRCUIT AND PARTS ARE SUBJECT TO CHANGE WITHOUT PRIOR  
 NOTICE.



# SCHEMATIC DIAGRAMS (2/2)

1

2

3

4

5

6

A

B

C

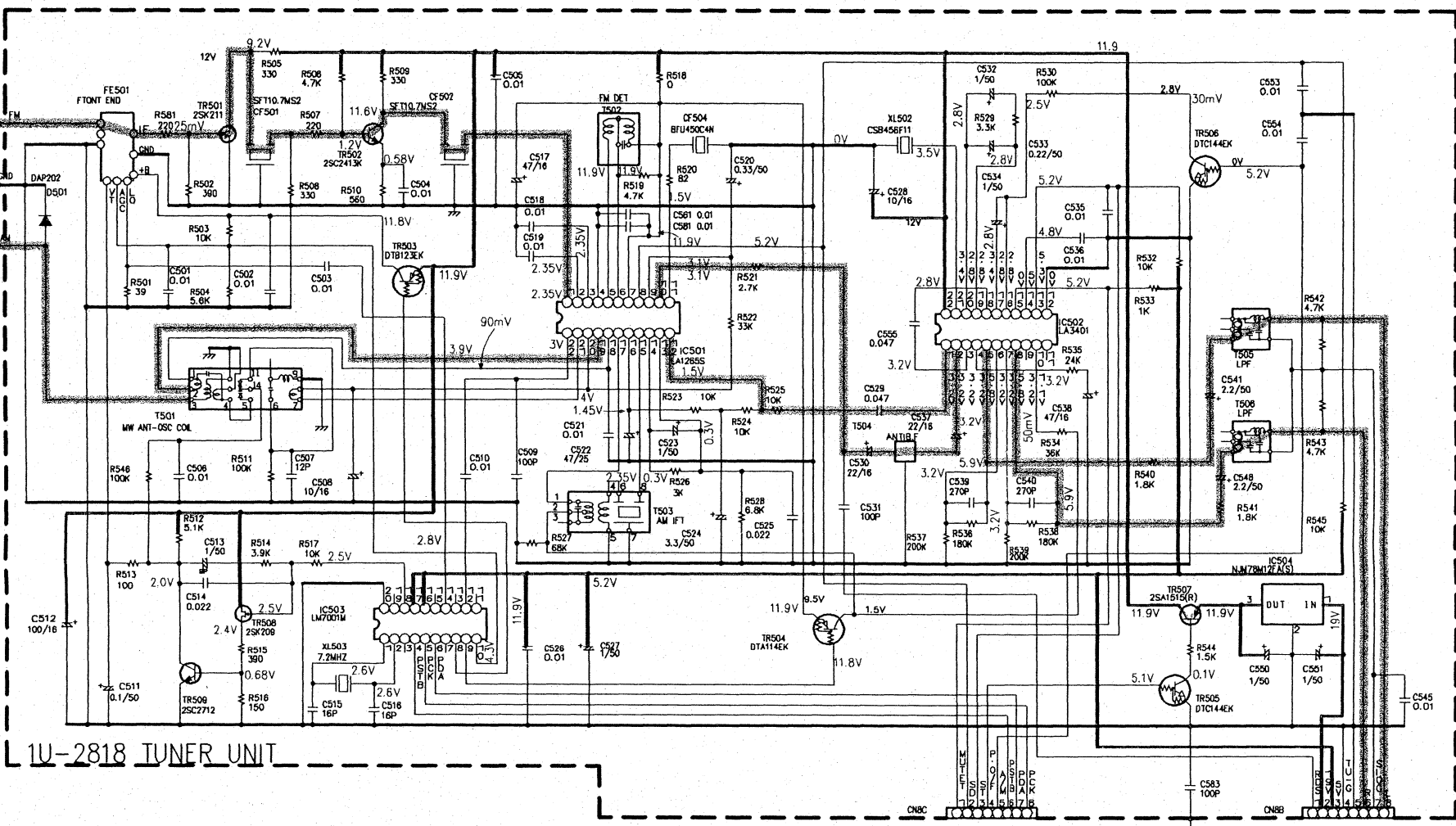

D

E

F

G

H

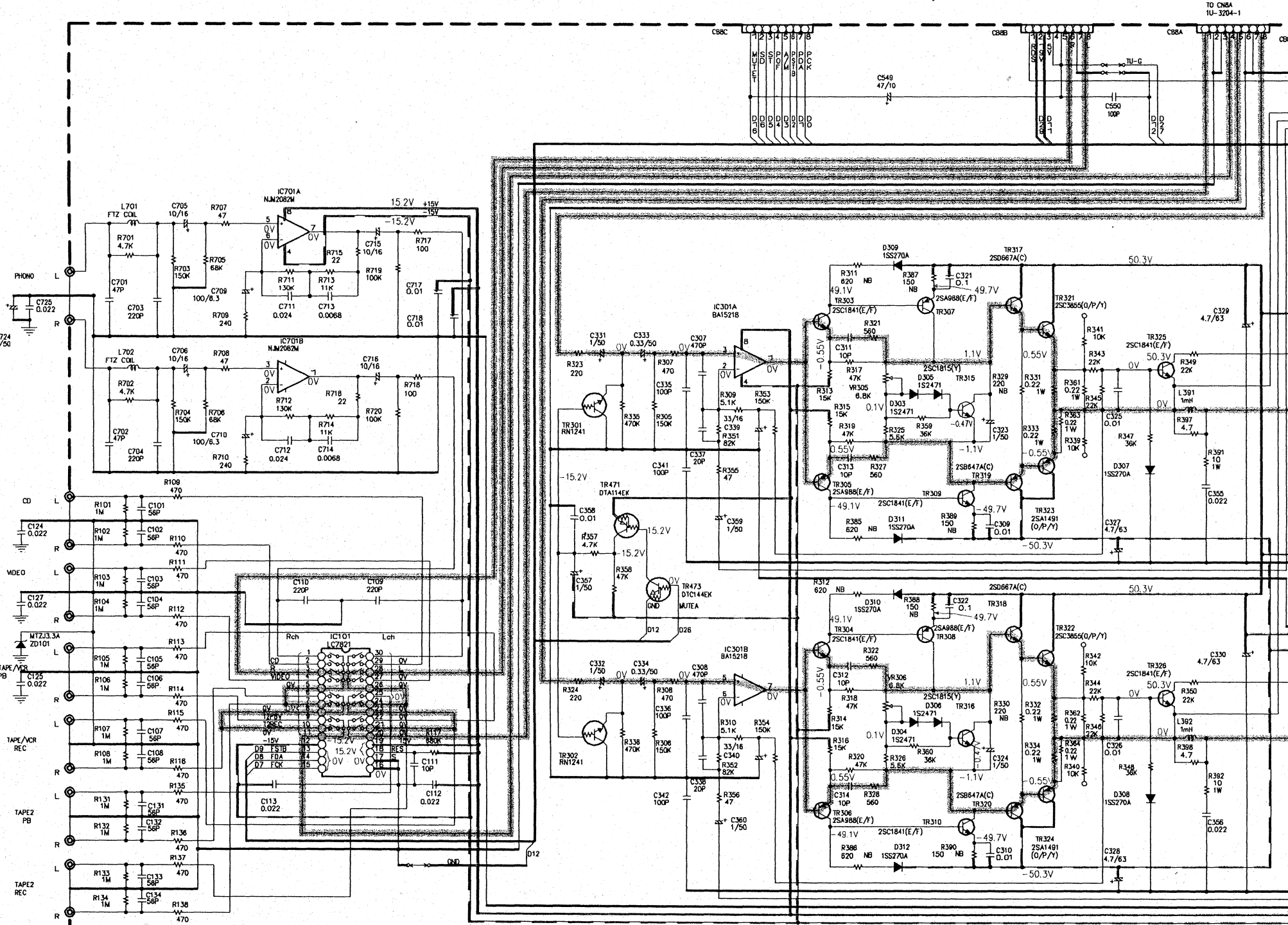



**NOTICE**

ALL RESISTANCE VALUES IN OHM. k=1,000 OHM M=1,000,000 OHM  
 ALL CAPACITANCE VALUES IN MICRO FARAD. P=MICRO-MICRO FARAD  
 EACH VOLTAGE AND CURRENT ARE MEASURED AT NO SIGNAL INPUT  
 CONDITION.  
 CIRCUIT AND PARTS ARE SUBJECT TO CHANGE WITHOUT PRIOR  
 NOTICE.

**WARNING:**

Parts marked with this symbol  have critical characteristics.  
 Use ONLY replacement parts recommended by the manufacturer.

**CAUTION:**

Before returning the unit to the customer, make sure you make either (1) a leakage current check or (2) a line to chassis resistance check. If the leakage current exceeds 0.5 milliamps, or if the resistance from chassis to either side of the power cord is less than 460 kohms, the unit is defective.

**WARNING:**

DO NOT return the unit to the customer until the problem is located and corrected.

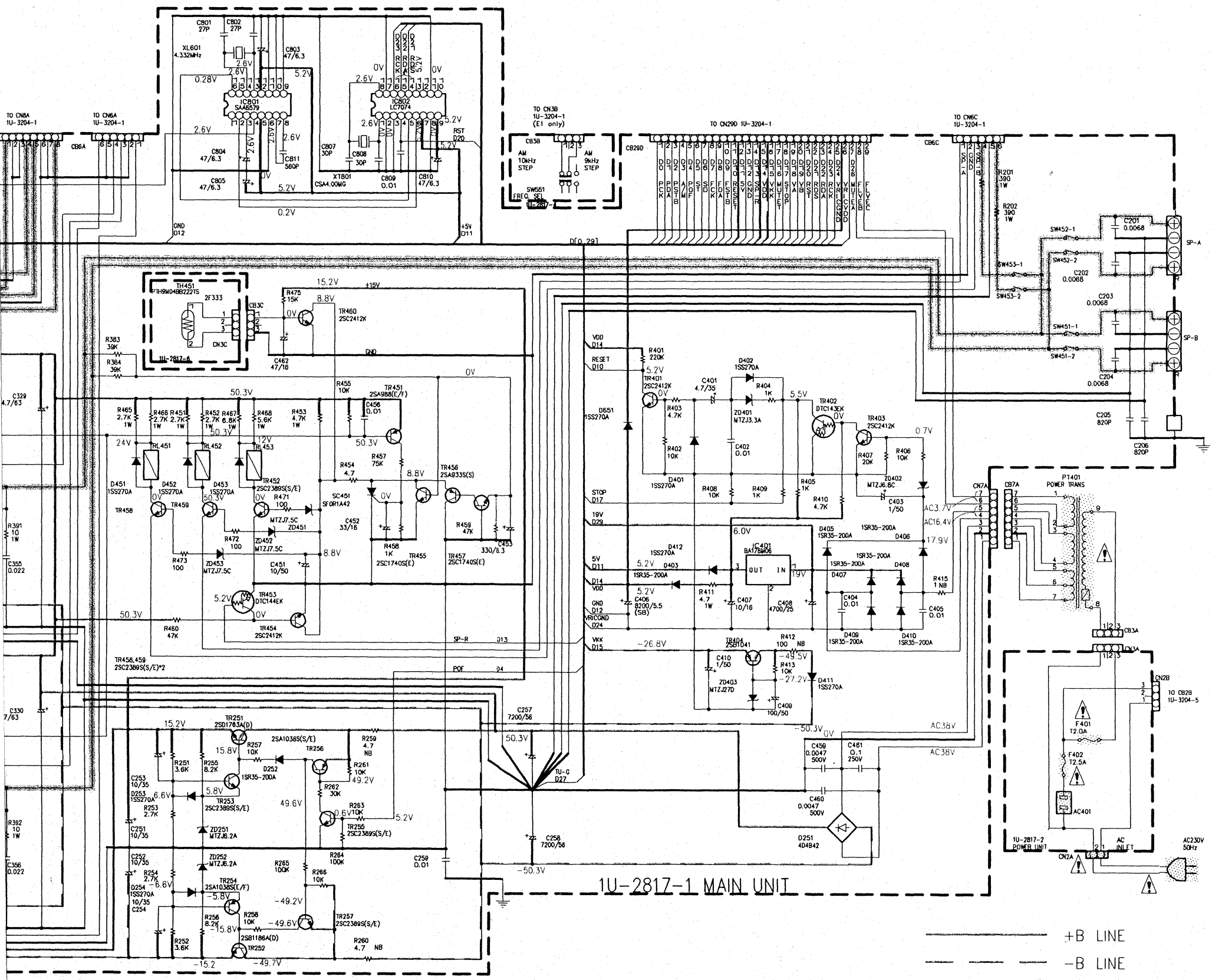

— +B LINE  
 - - - -B LINE  
 ——— SIGNAL LINE



DENO-00310

# DENON

Hi-Fi AM-FM Stereo Receiver

For Europe  
And U.K. Models

## SERVICE MANUAL MODEL DRA-585RD AM-FM STEREO RECEIVER

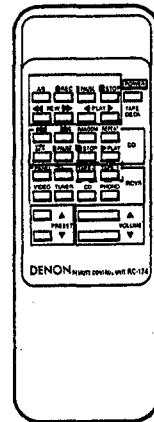
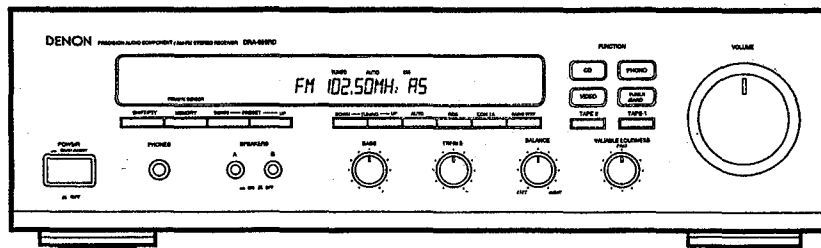

### TABLE OF CONTENTS

OPERATING INSTRUCTIONS .....	2-9
DISASSEMBLY .....	10
METHOD OF ADJUSTMENTS .....	11
CONNECTION DIAGRAM OF MEASURING INSTRUMENTS .....	12
BLOCK/LEVEL DIAGRAM .....	13
NOTE FOR PARTS LIST .....	14
PRINTED WIRING BOARD PARTS LIST .....	15-19
PRINTED WIRING BOARD PATTERNS .....	20, 21
1U-2817 MAIN UNIT ASS'Y .....	20
1U-2915 POWER UNIT ASS'Y .....	20
KU-9328 DISPLAY UNIT ASS'Y .....	21
1U-2818 TUNER UNIT ASS'Y .....	21
EXPLODED VIEW OF CHASSIS AND CABINET .....	22
PARTS LIST OF EXPLODED VIEW .....	23
WIRING DIAGRAM .....	24
SCHEMATIC DIAGRAM .....	25
SEMICONDUCTORS .....	26, 27

# NIPPON COLUMBIA CO., LTD.



**CAUTION**  
RISK OF ELECTRIC SHOCK  
DO NOT OPEN



**CAUTION: TO REDUCE THE RISK OF ELECTRIC SHOCK, DO NOT REMOVE COVER (OR BACK). NO USER SERVICEABLE PARTS INSIDE. REFER SERVICING TO QUALIFIED SERVICE PERSONNEL.**

The lightning flash with arrowhead symbol, within an equilateral triangle, is intended to alert the user to the presence of uninsulated "dangerous voltage" within the product's enclosure that may be of sufficient magnitude to constitute a risk of electric shock to persons.

The exclamation point within an equilateral triangle is intended to alert the user to the presence of important operating and maintenance (servicing) instructions in the literature accompanying the appliance.

**WARNING: TO REDUCE THE RISK OF FIRE OR ELECTRIC SHOCK, DO NOT EXPOSE THIS APPLIANCE TO RAIN OR MOISTURE.**

**PRECAUTIONS FOR INSTALLATION**  
Install DRA-585RD always horizontally. And leave at least 10 cm of space between the unit and other component placed above.

**VORKEHRUNGEN FÜR DIE AUFSTELLUNG**  
Stellen Sie den DRA-585RD stets waagrecht auf. Achten Sie ebenfalls darauf, daß ein Mindestabstand von 10 cm zwischen dem Gerät und der Komponente, die darüber gestellt wird, eingehalten wird.

**PRECAUTIONS D'INSTALLATION**  
Le DRA-585RD doit toujours être installé horizontalement. Laissez au moins un espace de 10 cm entre cet appareil et tout autre composant qui serait placé au-dessus.

**PRECAUZIONI PER L'INSTALLAZIONE**  
Installare il DRA-585RD sempre in posizione orizzontale, avendo cura di lasciare almeno 10 cm fra l'unità ed altri componenti posti al di sopra.

**PRECAUCIONES PARA LA INSTALACION**  
Instale siempre el DRA-585RD en posición horizontal. Asegúrese también de dejar un espacio de por lo menos 10 cm entre esta unidad y el componente que sea colocado encima.

**VOORZORGSMAATREGELEN VOOR INSTALLATIE**  
De DRA-585RD altijd horizontaal plaatsen. Laat ten minste 10 cm ruimte tussen het apparaat en het andere component dat u erboven plaatst.

**FÖRBEREDELSE FÖR INSTALLATION**  
Inställ alltid DRA-585RD horisontellt. Lämna åtminstone 10 cm mellan denna apparat och en annan komponent som placeras ovanpå.

**PRECAUÇÕES DURANTE A INSTALAÇÃO**  
Instale sempre o DRA-585RD em posição horizontal. E deixe pelo menos 10 cm de espaço entre esta unidade e o outro componente colocado acima.

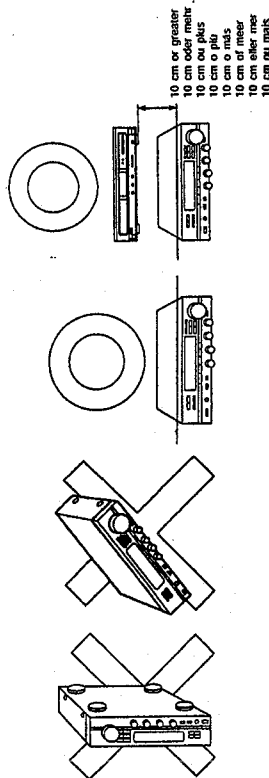

FRONT PANEL  
VORDERSEITE  
PANNELLO ANTERIORE  
PANEL ANTERIOR  
VOORPANEEL  
FRAMPANEEL  
PAINEL FRONTAL

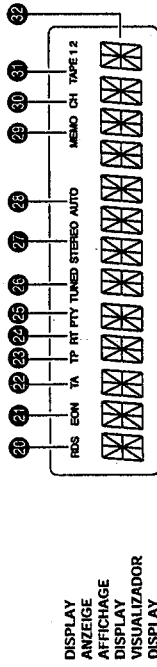
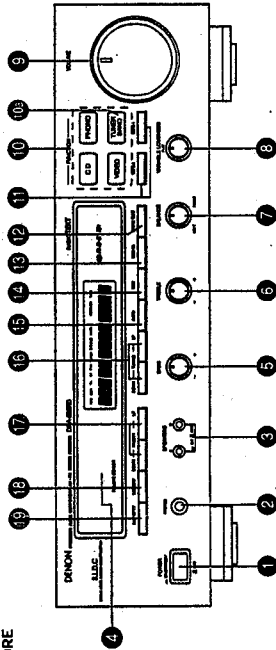

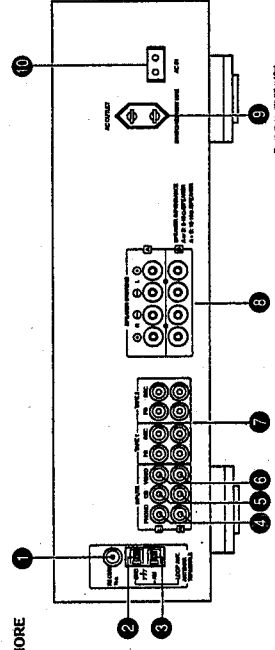

DISPLAY  
ANZEIGE  
AFFICHAGE  
DISPLAY  
VISUALIZADOR  
DISPLAYEN  
MOSTRADOR

REAR PANEL  
RÜCKSEITE  
PANNELLO POSTERIORE  
PANEL POSTERIOR  
ACHTERPANEEL  
BAKSIDAN  
PAINEL TRASEIRO



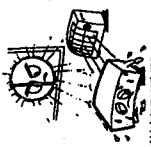

**NOTE ON USE / HIWWEISE ZUM GEBRAUCH / OBSERVATIONS RELATIVES A L'UTILISATION  
NOTE SULL'USO / NOTAS SOBRE EL USO / ALVORENS TE GEBRUIKEN / OBSERVERA  
OBSERVAÇÕES SOBRE O USO**

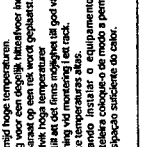
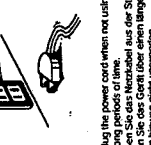
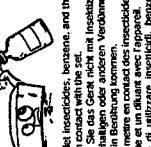
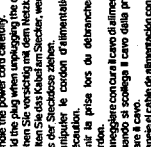
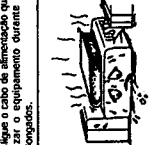
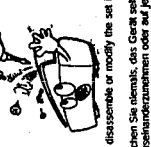
 <ul style="list-style-type: none"> <li>• Avoid high temperatures.</li> <li>• Vermeden Sie hohe Temperaturen.</li> <li>• Bewahren Sie das Gerät vor Feuchtigkeit, Wasser und Staub fern.</li> <li>• Protéger l'appareil contre l'humidité, l'eau et la poussière.</li> <li>• Beschützen Sie das Gerät vor Feuchtigkeit, Wasser und Staub fern.</li> <li>• Mantenga el equipo libre de humedad, agua y polvo.</li> <li>• Bewahren Sie das Gerät vor Feuchtigkeit, Wasser und Staub fern.</li> <li>• Evite temperaturas altas.</li> <li>• Quando instalar o equipamento nunca desproteja o mesmo do calor.</li> </ul>	 <ul style="list-style-type: none"> <li>• Keep the set free from moisture, water and dust.</li> <li>• Halten Sie das Gerät von Feuchtigkeit, Wasser und Staub fern.</li> <li>• Protéger l'appareil contre l'humidité, l'eau et la poussière.</li> <li>• Beschützen Sie das Gerät vor Feuchtigkeit, Wasser und Staub fern.</li> <li>• Mantenga el equipo libre de humedad, agua y polvo.</li> <li>• Bewahren Sie das Gerät vor Feuchtigkeit, Wasser und Staub fern.</li> <li>• Evite temperaturas altas.</li> <li>• Quando instalar o equipamento nunca desproteja o mesmo do calor.</li> </ul>	 <ul style="list-style-type: none"> <li>• Do not let foreign objects in the set.</li> <li>• Lassen Sie keine Fremdkörper in das Gerät fallen.</li> <li>• Ne laissez pas d'objets étrangers dans l'appareil.</li> <li>• Vermeiden Sie das Einbringen von Fremdkörpern in das Gerät.</li> <li>• No permita que objetos extraños caigan en el equipo.</li> <li>• Bewahren Sie das Gerät vor dem Einbringen von Fremdkörpern.</li> <li>• Evite deixar objectos estranhos sobre o aparelho.</li> </ul>
 <ul style="list-style-type: none"> <li>• Handle the power cord carefully.</li> <li>• Gehen Sie vorsichtig mit dem Netzkabel um.</li> <li>• Manipuler le cordon d'alimentation avec précaution.</li> <li>• Manövrieren Sie das Netzkabel vorsichtig.</li> <li>• Quando o cabo de alimentação estiver conectado, não puxe o mesmo para não danificar o equipamento.</li> </ul>	 <ul style="list-style-type: none"> <li>• Use the power cord when not using the set for long periods of time.</li> <li>• Ziehen Sie das Netzkabel aus der Steckdose, wenn Sie das Gerät über einen längeren Zeitraum nicht benutzen.</li> <li>• Branchez le cordon d'alimentation lorsque l'appareil n'est pas utilisé pendant de longues périodes.</li> <li>• Quando o aparelho não estiver sendo utilizado por um longo período de tempo, desconecte o cabo de alimentação da tomada.</li> <li>• Desconecte el cable de alimentación cuando no utilice el equipo por mucho tiempo.</li> <li>• Quando o aparelho não estiver sendo utilizado por um longo período de tempo, desconecte o cabo de alimentação da tomada.</li> <li>• Die zur Nutzung des Apparates mitgelieferten Netzkabel sind für den Einsatz als Ersatzkabel für andere Modelle nicht geeignet.</li> <li>• Desligue o cabo de alimentação quando não utilizar o equipamento durante períodos prolongados.</li> </ul>	 <ul style="list-style-type: none"> <li>• Do not let insecticides, benzene and thinner come in contact with the set.</li> <li>• Lassen Sie das Gerät nicht mit Insektiziden, Benzin oder Lösungsmitteln in Berührung kommen.</li> <li>• Ne pas mettre en contact des insecticides, du benzène et d'un diluant avec l'appareil.</li> <li>• Vermeiden Sie den Kontakt mit Insektiziden, Benzin und Lösungsmitteln.</li> <li>• No permita que insecticidas, benceno o disolventes entren en contacto con el equipo.</li> <li>• Bewahren Sie das Gerät vor dem Kontakt mit Insektiziden, Benzin und Lösungsmitteln.</li> <li>• Evite que inseticidas, benzina e diluente entrem em contacto com o equipamento.</li> </ul>
 <ul style="list-style-type: none"> <li>• Handle the power cord carefully.</li> <li>• Gehen Sie vorsichtig mit dem Netzkabel um.</li> <li>• Manipuler le cordon d'alimentation avec précaution.</li> <li>• Manövrieren Sie das Netzkabel vorsichtig.</li> <li>• Quando o cabo de alimentação estiver conectado, não puxe o mesmo para não danificar o equipamento.</li> </ul>	 <ul style="list-style-type: none"> <li>• Use the power cord when not using the set for long periods of time.</li> <li>• Ziehen Sie das Netzkabel aus der Steckdose, wenn Sie das Gerät über einen längeren Zeitraum nicht benutzen.</li> <li>• Branchez le cordon d'alimentation lorsque l'appareil n'est pas utilisé pendant de longues périodes.</li> <li>• Quando o aparelho não estiver sendo utilizado por um longo período de tempo, desconecte o cabo de alimentação da tomada.</li> <li>• Desconecte el cable de alimentación cuando no utilice el equipo por mucho tiempo.</li> <li>• Quando o aparelho não estiver sendo utilizado por um longo período de tempo, desconecte o cabo de alimentação da tomada.</li> <li>• Die zur Nutzung des Apparates mitgelieferten Netzkabel sind für den Einsatz als Ersatzkabel für andere Modelle nicht geeignet.</li> <li>• Desligue o cabo de alimentação quando não utilizar o equipamento durante períodos prolongados.</li> </ul>	 <ul style="list-style-type: none"> <li>• Do not disassemble or modify the set in any way.</li> <li>• Zerlegen Sie das Gerät nicht.</li> <li>• Ne jamais démontez ou modifiez l'appareil.</li> <li>• Das Gerät darf nicht auseinandergebaut oder verändert werden.</li> <li>• No desmonte o modifique o equipo de forma alguna.</li> <li>• Bewahren Sie das Gerät vor dem Zerlegen oder Verändern.</li> <li>• Evite desmontar o modificar o equipamento de alguma forma.</li> </ul>

Please check the following items are included with the main unit in the carton:

- (1) Operating instructions
- (2) AM Loop Antenna
- (3) FM Antenna
- (4) Remote Control RC-174
- (5) Batteries R6 (AA)
- (6) AC Cord

Verifiez que les articles suivants sont bien joints à l'appareil principal dans le carton:

- (1) Mode d'emploi
- (2) Antenne-cadre AM
- (3) Antenne FM
- (4) Télécommande RC-174
- (5) Piles de format R6 (AA)
- (6) Cordon secteur

Controllare che le parti seguenti si trovino imballate con l'apparecchio nella scatola di spedizione:

- (1) Istruzioni per l'uso
- (2) Antenna AM a telaio
- (3) Antenna FM
- (4) Telecomando RC-174
- (5) Batterie a secco R6 (AA)
- (6) Cavo d'alimentazione

Verifique que los artículos siguientes hayan sido suministrados con la unidad principal:

- (1) Instrucciones de operación
- (2) Antena AM de cuadro
- (3) Antena de FM
- (4) Unidad de control remoto RC-174
- (5) Pilas secas R6 (AA)
- (6) Cable de alimentación

Controleer of de volgende accessoires bij het hoofdtoestel in de doos zijn verpakt:

- (1) Gebruiksaanwijzing
- (2) AM-raamantenne
- (3) FM-antenne
- (4) Afstandsbediening RC-174
- (5) R6 (AA) droog cel batterij
- (6) Netkabel

Kontrollera att följande tillbehör har packats ner i kartongen tillsammans med huvudenheten:

- (1) Bruksanvisning
- (2) Ramantenn för AM-buk
- (3) FM-antenn
- (4) Fjärrkontroll RC-174
- (5) R6 (AA) laddbatteri
- (6) Nätledaren

Verifique se os itens que se seguem estão incluídos na caixa de cartão com o aparelho principal:

- (1) Instruções de funcionamento
- (2) Antena de quadro AM
- (3) Antena FM
- (4) Telecomando RC-174
- (5) Pilhas R6 (AA)
- (6) Cabo de alimentação

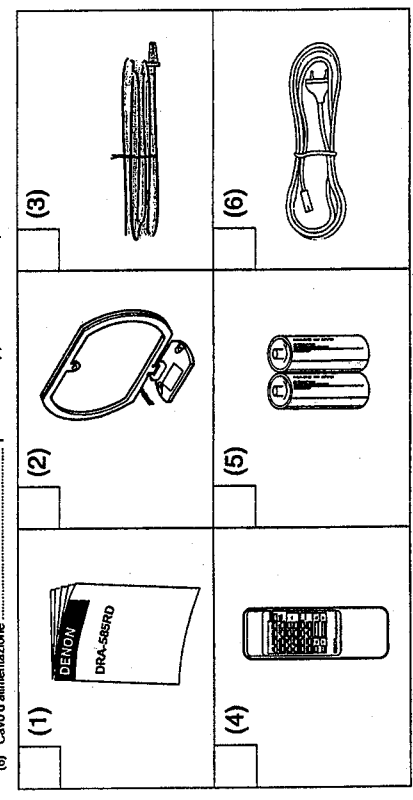

**NUR FÜR EUROPÄISCHE MODELLE:**  
Konformitätserklärung  
Die DENON Elektronik GmbH  
40880 Ratingen  
erklärt das Hersteller/Importeur, daß das in dieser Bedienungsanleitung beschriebene Gerät den Technischen Vorschriften für Ton- und Fernseh-Rundfunkempfänger nach der Amtsblattverfügung 868/1989 (Amtsblatt des Bundesministers für Post und Telekommunikation vom 31.8.1989) entspricht.

**CONNECTIONS**

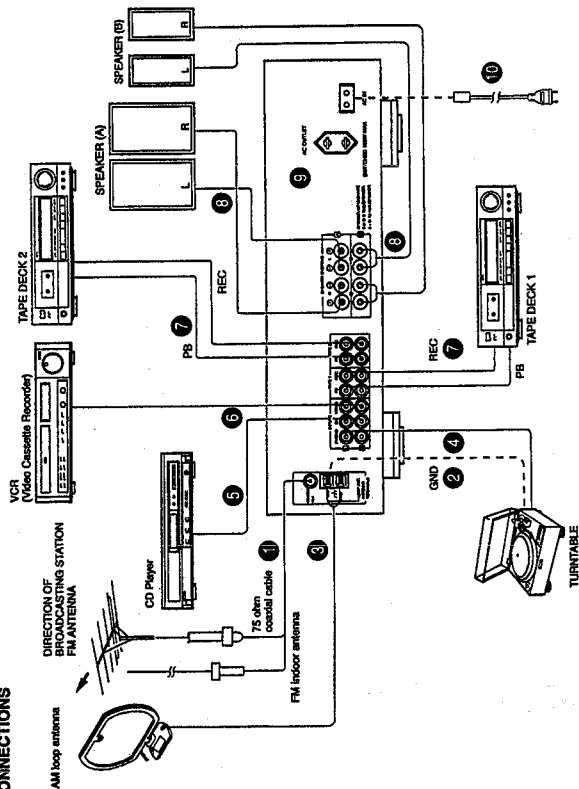

**Notes on Connection**

- Do not plug the power cord into the AC wall outlet until all connections have been completed.
- Make sure channels are correctly connected. Connect Left channels to Left channels and Right channels to Right channels. Follow the color markings of plugs and terminals to make sure mistakes are not made.
- Connect all pin-plugs securely, pushing them completely into the jacks. Incomplete connections will cause noise generation.
- Binding the connection cables to power cords, or running such cables close to power supply transformers will cause humming or noise, and should thus be avoided.

**SPEAKER CONNECTION**

Confirm polarity (+, -) and left and right channels (L, R). Connect the speaker pairs to the SPEAKER terminals A or B on the back panel. Connections must be made with power cord disconnected.

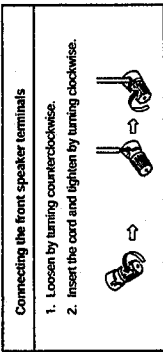
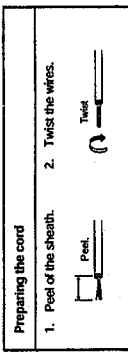

**ANTENNA INSTALLATION**

**FM ANTENNA**  
The supplied indoor FM antenna can be used inside wooden houses for receiving local FM stations and other strong FM signals. Stretch out the end of the antenna and mount the antenna on the wall in a ceiling where optimum reception is expected. Reception of FM signals is affected by the scale of reception, due to environment changes. In such cases, the indoor FM antenna should only be used temporarily until an outdoor FM antenna has been installed. When connecting an outdoor FM antenna, the use of 75 ohm coaxial cable (3C-2V, 6C-2V) is strongly recommended.

**AM ANTENNA**  
Attach the supplied AM loop antenna even when using an outdoor AM antenna. Connect the leads to the AM and GND terminals. Also use the AM terminals for connecting an outdoor AM antenna (when making such a connection do not disconnect the AM loop antenna). Adjust the loop antenna to obtain optimum reception. Where broadcast stations are distant and only weak signals are received, where signals are blocked, it is best to install an outdoor AM antenna.

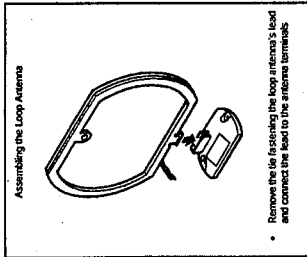

**Notes:**

- Do not connect the FM antennas simultaneously.
- When using an AM antenna to use, do not disconnect the AM loop antenna.
- Make sure AM loop antenna lead terminals do not touch metal parts of the panel.

REAR PANEL (Refer to page 6 and page 7.)

- 1 FM ANT (FM antenna terminals)  
15-ohm coaxial cable can be connected to this terminal. For antenna connecting procedure, see ANTENNA INSTALLATION.
- 2 GND (Grounding terminal)  
The ground wire of this terminal is connected here.
  - Hum or noise may be generated if the grounding wire is not connected.
- 3 AM ANT (AM antenna terminals)  
Connect the attached AM loop antenna.  
Connect to this terminal when a medium wave outdoor antenna is used.
- 4 PHONO (Phono input terminals)  
The output cord of the turntable is connected here.  
Since the input sensitivity of "PHONO" is extremely high, do not use the unit without the input phn cord. If used without this cord, the speakers may generate hum.
- 5 CD  
The output cord of the CD player is connected here.
- 6 VIDEO  
A VIDEO, such as a VCR or Video Disc may be connected here.
- 7 TAPE-1, TAPE-2  
Two tape decks or tape deck can be connected to these jacks for full-featured playback, recording and tape dubbing operation.
- 8 SPEAKER SYSTEMS (Speaker terminals)  
Two pairs of speakers A and B can be connected to these terminals.
- 9 AC OUTLET (AC power outlet)  
This AC outlet is controlled by the power switch.  
(Except units are sold in U.K. and Eire).
- 10 AC Inlet  
Connect the included AC cord here.

CAUTION

**Protective Circuit**  
This set is equipped with a high speed protective circuit. This circuit protects the internal circuitry from damage due to large currents flowing when the speaker jacks are not completely connected or when an output is generated by a short circuit.  
If the protective circuit's operation cuts off the output to the speaker, the speaker terminals are disconnected to the set and check the connection to the speakers. Then turn the power on again. After muting for several seconds, the set will operate normally.

DESIGNATIONS AND FUNCTIONS OF PANEL CONTROLS (Refer to Page 3.)

FRONT PANEL

- 1 POWER (Power ON-STANDBY/OFF Switch)  
This switch turns the unit ON or OFF. There is a delay of a few seconds before the unit will operate after this power switch is turned ON. If the unit is turned OFF from the remote control, the unit will be in the STANDBY mode. When in the STANDBY mode, the unit can be turned ON by the remote control. However, the power switch will not be used for extended period. Be sure to turn the unit OFF from the front panel power switch.  
NOTE: This unit includes a STANDBY protection feature. This feature is designed to prevent accidental turn-on from the STANDBY mode in the event of a power failure. Should the unit is in STANDBY mode, the unit will return the STANDBY mode.  
To turn the unit ON from the STANDBY mode without the remote control, operate the front panel power switch four times. The unit will then operate normally.
- 2 PHONES (Headphones jack)  
Connect a pair of headphones (sold separately) to this jack for private listening.
- 3 SPEAKERS (Speaker selector switches)  
These switches are used to select speaker system A and B. No sound is heard through the speakers when both switches are reset to the (A) position.
- 4 REMOTE SENSOR (Remote control sensor)  
This sensor receives the infra-red light transmitted from the wireless remote control unit.  
For remote control, point the wireless remote control unit towards the sensor.
- 5 BASS (Bass control)  
Use this control to adjust the low-range response. When the control is set to the center position, the frequency characteristic curve (below 1,000 Hz) is flat. Turn the control clockwise to increase the bass response and counterclockwise to decrease it.
- 6 TREBLE (Treble control)  
Use this control to adjust the high-range response.  
When the control is set to the center position, the frequency characteristic curve (above 1,000 Hz) is flat. Turn the control clockwise to increase the treble response and counterclockwise to decrease it.
- 7 BALANCE (Balance control)  
Use this control to balance the volume levels between left and right channels. The volume levels in both channels are equal when the control is set to the center position.
- 8 VARIABLE LOUDNESS (Loudness control)  
At low volumes, the human ear is less sensitive to low (BASS) and high (TREBLE) frequencies. Use this control to compensate for this deficiency when listening at low volume levels. Turn this control counterclockwise until a natural balance of bass and treble sound has been restored.
- 9 VOLUME (Volume control)  
This knob is used to adjust the volume level of both channels. Turn the knob clockwise to raise the volume and counterclockwise to lower it.
- 10 Input selector (Input selector buttons)  
These buttons are used to select the audio input source.  
• PHONO: Press to play a record on a record player connected to the PHONO input jacks.  
• CD: Press to listen to a compact disc player or another compact disc player connected to the CD input jacks.  
• TUNER: Press to select the FM or AM programs, when the set is not TUNER function.  
• VIDEO: Use when playing back the audio from a Hi-Fi video, video disc player or other component connected to the VIDEO terminal.
- 11 BAND (Band selector button)  
Press this button to select the FM or AM (M/W) band, when the set is in TUNER function.
- 12 Tape selector (Tape selector/monitor buttons)  
TAPE-1: Press this button, TAPE-1 indicator will light up and then you can play tape source on TAPE-1 terminal.  
TAPE-2: Press this button once, TAPE-2 indicator will light up and then you can play tape or video source of TAPE-2 terminal. In this state you can copy TAPE-2 source to TAPE-1 terminal. Press again the button currently accessed, to play sources selected by input selector 10, indicator goes out.
- 13 RADIO TEXT button  
This button is used for displaying radio text messages. When this button is pressed while the station currently tuned in is offering a radio text message service, the message scrolls on the display. This mode turns on and off each time the button is pressed. (Refer to page 13.)
- 14 EON TA button  
When a traffic announcement begins on a station in the same network as the station currently tuned in, that network station is automatically tuned in, and the previous station is tuned back in once the traffic announcement is over.  
This button is used to turn this mode on and off.  
If the station switches from the current station to the network station when this mode is set on, the network station cannot be received properly. Check signals of the previous station is immediately tuned back in. (Refer to page 13.)
- 15 RDS (RDS button)  
This button is used for the RDS search (refer to page 12) and PTY search (refer to page 12 and 13) search (refer to page 12) operations, and to input the station name (refer to page 11).



- 14 **AUTO (Tuning mode button)**  
This switches between auto and manual tuning. Auto tuning: When the UP button is pressed, the radio is tuned automatically to a higher frequency. Press the DOWN button to tune to a lower frequency. Use this position to eliminate noise when no signals or weak signals are being received? Manual tuning: In this position, the radio can be tuned manually. Reception is automatically manual when in the manual mode.
- 15 **TUNING (Tuning buttons)**  
Use these to change the received frequency to a higher frequency (UP) or a lower frequency (DOWN). When writing station names, use these buttons to select the letters. (Refer to Page 11.)
- 16 **Presets (Preset station buttons)**  
These buttons are used for saving stations or recalling stations which have been preset. Using the SHIFT/PTY button you can preset a total of 40 FM or AM stations into preset channels. Once a radio has been memorized, the same station can later be tuned instantly simply by recalling the corresponding preset channel with PRESET UP or DOWN button.

**DISPLAY**

- 20 **RDS indicator**  
This lights when receiving RDS broadcasts, and flashes during the RDS search operation.
- 21 **EON indicator**  
This lights when receiving EON information.
- 22 **TA indicator**  
This lights when receiving traffic announcements.
- 23 **TP indicator**  
This flashes during the TP search operation and lights when TP stations are tuned in.
- 24 **RT indicator**  
This lights when the RADIO TEXT button is pressed.
- 25 **PTY indicator**  
This flashes during the PTY (Programme Type) search operation.
- 26 **TUNED indicator**  
This lights when a station is properly tuned in.
- 27 **STEREO indicator**  
This lights when receiving stereo broadcasts. It remains off when receiving AM broadcasts.

**USING THE VARIOUS FUNCTIONS**

1. Using the auto preset memory function  
This function automatically stores the FM stations which can be received in the area in which the set is being used in the preset memory. Use this function so that the RDS functions can be used. The RDS functions will be active only when the station name is changed as will from after the preset stations have been stored with this function.  
**Operation**  
1. Connect the FM antenna and set so that FM stations can be received.  
2. Press the POWER button to turn on the power while holding in the MEMORY button.  
3. Searching begins automatically, and stations are stored in the preset memory in order, beginning from channel A1. (The operation automatically stops once 40 stations have been set in the memory.)
2. Storing new stations at the preset channels  
The reception frequency, RDS service information, Tuning mode and input characters can be stored at the different channel memories.  
When this operation is performed, the station already stored in the preset memory using the auto preset memory function is cleared.  
**Operation**  
1. Press the MEMORY button (The MEMO indicator flashes.)  
2. Use the SHIFT/PTY button to select the block, A to E.  
3. Use the PRESET UP or DOWN button to select the channel at which the station is to be stored.  
4. Press the MEMORY button again to store the station in the memory.
3. Recalling preset channels  
Use the following operation to recall preset channels:  
**Operation**  
1. Use the SHIFT/PTY button to select the block, A to E.  
2. Use the PRESET UP or DOWN button to recall the station stored in this block.  
3. If the PRESET UP or DOWN buttons are pressed without pressing the SHIFT/PTY button, the stations are recalled in the order A1 to A8, B1 to B8, and so on through E8.

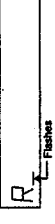
4. Inputting characters  
Any characters can be input (up to 8 characters). The input characters can be stored at the preset channels.  
**Operation**  
1. Press the RDS button four times. (The cursor flashes at the first place.)  
  
2. Use the TUNING UP or DOWN button to select the character for the first place. (The selected character flashes.)  
  
3. Press the SHIFT/PTY button to move the cursor to the next place. (The cursor flashes at the second place.)  
  
4. Repeat steps 2 and 3 above to input up to 8 characters.

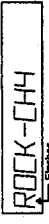

5. The characters are set five seconds after the input procedure is finished. The input characters can be stored in the memory. To keep the input characters, be sure to store them in a channel memory.  
**Clearing characters**  
1. Recall the character you want to clear.  
2. Press the RDS button 4 times until the character at the first place flashes.  
3. Then press the SHIFT/PTY button for at least 2 seconds. The current character will then be cleared.

Table of characters  
The characters are input in the order shown to the right. Use the TUNING buttons to select the desired characters.

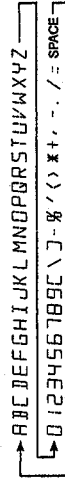

**RDS Emergency Alarm**  
 "ALARM" will flash on the display when the unit receives the Emergency Programme Type Code (PTY31) from an RDS station. This feature may not operate properly if the signal from the RDS station is too weak or is subjected to interference. It is not possible to select the "ALARM" display from the PTY search mode.

- NOTE:**
1. Be sure to turn the EON TA mode off when recording programmes.
  2. In the EON TA mode, if the stations in the network are not the same, the stations are weak and it cannot be tuned in properly, "WEAK SIGNAL" is displayed and the original station is immediately tuned back in.
  3. In the EON TA mode, the station does not switch to another station in the network if the current station is broadcasting a traffic announcement.
  4. Since the RDS services offered differ from station to station, some RDS functions may not operate for some stations, but this is not a malfunction.

**4. RADIO TEXT**  
 When the RADIO TEXT button (R) is pressed while the station message scrolls on the display, a radio text message service, the message scrolls on the display. (The RT indicator lights when the RADIO TEXT button is pressed.)

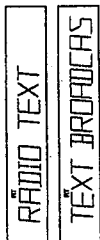

(NO TEXT DATA\* is displayed if no radio text message is being broadcast.)

**5. EON TA**  
 When an RDS station is broadcasting RDS information on other stations which are in the same network and a traffic announcement begins on another station in the same network based on this information (EON-Enhanced/Other Network), that network station is automatically tuned in. The previous station is tuned back in once the traffic announcement is over.

**Operation**  
 1. Press the EON TA button (E). (The EON TA indicator lights.)



(When a traffic announcement starts, that station is automatically tuned in.)



(When the traffic announcement is over, the previous station is tuned back in.)



4. Searching begins again if the PRESET UP or DOWN button (P) is pressed while the PTY indicator is flashing.

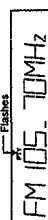

5. If no other station broadcasting the designated programme type is found when all the frequencies are searched, "NO PROGRAMME" is displayed.

List of PTY (Programme Type) displays:

1. NEWS
2. AFFAIRS
3. INFORMATION
4. SPORT
5. EDUCATION
6. DRAMA
7. CULTURE
8. SCIENCE
9. VARIED
10. POP MUSIC
11. ROCK MUSIC
12. M.O.R. MUSIC
13. L-CLASSICS (Light Classics)
14. S-CLASSICS (Serious Classics)
15. OTHER MUSIC
31. ALARM

**NOTE:** ALARM cannot be selected during the PTY search operation.

**3. TP Search**

Use this to automatically search and stop at stations which broadcast traffic announcements (even if the station is not currently broadcasting a traffic announcement).

**Operation**

1. Press the RDS button (R) three times.



2. Press the PRESET UP or DOWN button (P). (Searching begins.)



3. Searching begins again if the PRESET UP or DOWN button (P) is pressed while the TP indicator is flashing.

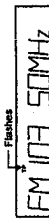

4. If no other TP station is found when all the frequencies are searched, "NO PROGRAMME" is displayed.

**Using the RDS functions (for FM only)**  
**1. RDS search**  
 Use this to automatically search and stop at stations offering RDS services.

- Operation**  
 1. Press the RDS button (R) once.

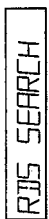

2. Press the PRESET UP or DOWN button (P). (Searching begins.)



3. Searching begins again if the PRESET UP or DOWN button (P) is pressed while the RDS indicator is flashing.

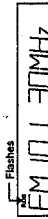

4. If no other RDS station is found when all the frequencies are searched, "NO RDS" is displayed.

**2. PTY Search**

Use this to automatically search and stop at stations broadcasting the specified programme type (PTY).

**Operation**

1. Press the RDS button (R) twice.



2. Use the SHIFT/PTY button (S) to select the programme type.

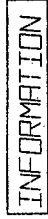

3. Press the PRESET UP or DOWN button (P). (Searching begins.)

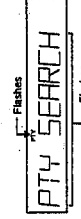

**PLAYBACK USING THE REMOTE CONTROL**

The accessory RC-174 remote control unit is used to control the RECEIVER from a distance.

- Inserting the dry cell batteries



- Remove the rear cover on the remote control unit.

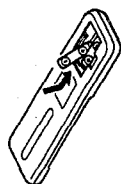

- Replace the rear cover.



- Directions for use

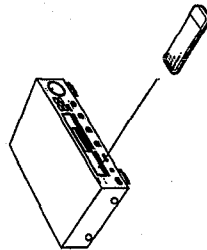

**Notes on Use of the Batteries**

- The remote control unit uses size "AA" (R6) dry cell batteries. The batteries will need to be replaced approximately once a year. This will depend upon how often the remote control is used.
- In less than a year from the time new batteries were inserted, the remote control fails to operate the receiver from a nearby position, it is likely that the batteries are inserted in the wrong position, the batteries are properly inserted, the diagram on the remote control battery supply unit, and making sure to align the plus and minus sides of each battery.
- Batteries are prone to damage and leakage. Therefore:
  - Do not combine different types of batteries.
  - Do not jumper the opposite poles of the batteries; expose them to heat or break them open, or put them into open fire.
- When the remote control is not to be used for a long period of time, remove the batteries from the unit.
- If the batteries have leaked, remove any battery fluid from the inside of the battery supply unit by wiping it out thoroughly and insert new batteries.

- Operate the remote control unit while pointing it towards the remote control sensor on the receiver as shown in the diagram left.
- The remote control unit can be used at distances up to about 8 meters in a straight line from the receiver. This distance will decrease if there are obstructions blocking the infra-red light transmission. If the remote control unit is not directed straight at the receiver.

**Note on Operation**

- Do not press the operating buttons on the receiver and the remote control unit at the same time. This will cause misoperation.
- Operation of the remote control unit will become less effective or cease if the infrared remote control sensor on the receiver is exposed to strong light or if there are obstructions between the remote control unit and the sensor.
- In case you operate your VCR, TV or other components by remote control, do not operate buttons on two different remote control units at the same time. This will cause misoperation.

Besides being able to operate the DRA-585RD receiver with this remote control unit, you can also operate a DENON cassette deck and CD player from this handy full-system remote control unit.

**Remote Control Section**  
Full-System Remote Control Unit

The full-system remote control unit operates all major functions of the receiver such as function switching, volume control, and preset station selection. But that's not all! The same control pad can also control the major functions of a DENON CD player and cassette deck to create a remarkably ergonomic and versatile DENON system with all the quality sound reproduction that the devoted audiophile expects.

**Remote Control Unit RC-174 supplied with DRA-585RD**

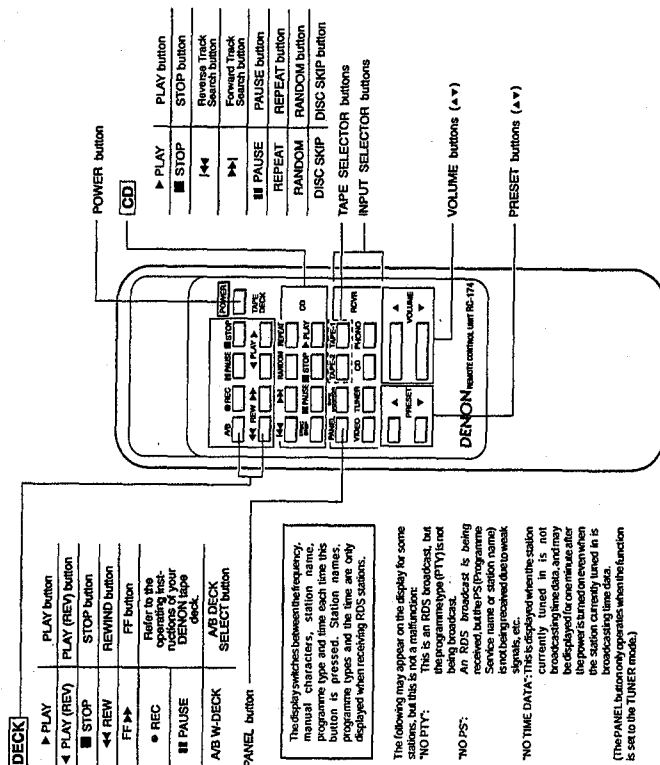

- The RC-174 Remote Control Unit can control CD players and cassette decks made by DENON.
  - Note the operation may not be possible for some models.
  - Buttons are conveniently separated into groups, each group controlling one specific component. The groups are RECEIVER, CD and DECK.
- For details on operating other components, refer to the instruction manuals for the CD player and/or cassette deck.

**CAUTION:**

- If the panel is turned off with the remote control unit, the receiver is switched to the power stand-by state. If you are to be absent for a long period of time, be sure to turn the power on using the POWER switch on the receiver.
- A part of the light of the power stand-by state.
- You may experience erratic operation of the receiver if it is operated in fluorescent light and direct sunlight, in particular if this light strikes the remote control sensor on the receiver. However, this is not a malfunction, and if this should happen, protect the sensor against such light.

**SPECIFICATIONS**

**AMPLIFIER SECTION**

Continuous Power Output  
Power Bandwidth (BPF):  
Total Harmonic Distortion:  
Frequency Response:

90 W ± 50 W (± 0.5 dB, 1 kHz)  
10 Hz - 40 kHz (F.H.D. 0.15% both channels driven into 8 ohms)  
0.05% (3 dB at rated output & above)  
PHONO RMA Standard Curve (Recording Out-put)  
MM 20 Hz - 20 kHz ± 0.5 dB  
CD, VIDEO, TAPE 1, TAPE 2 10 Hz - 15 kHz

**TUNER SECTION**

[F<sub>max</sub>] (note: (W at 75 ohms, 0 dB) = 1 × 10<sup>-W</sup>)  
Frequency Response:  
Usable Sensitivity:  
Signal to Noise Ratio (BPF-A):  
MONO 82 dB  
STEREO 78 dB  
FM 55 dB  
55 dB  
30 Hz - 15 kHz ± 0.2 dB  
± 1.5 dB

**Input Sensitivity and Impedance:**

PHONO MM 2.5 mV 47 kohms  
CD, VIDEO, TAPE 1, TAPE 2 150 mV 25 kohms

**Maximum Input Level:**

(at 1 kHz)  
Signal to Noise Ratio (BPF-A):  
PHONO MM 120 mV  
CD, VIDEO, TAPE 1, TAPE 2 78 dB (at 5.0 mV input)  
78 dB

**Tone Controls:**

BASS ± 10 dB at 100 Hz  
TREBLE ± 10 dB at 10 kHz  
Variable Loudness at maximum position  
50 Hz/10 kHz, ± 10 dB/± 5 dB

**Loudness Control Effect:**

50 Hz/10 kHz, ± 10 dB/± 5 dB

**Usable Sensitivity:**

(at 1 kHz)  
Signal to Noise Ratio:  
15 µV  
55 dB

**General:**

Power Supply: AC 230 V 50 Hz  
Power Consumption: 190 W  
Power Outlet: SWITCHED 100 W  
Dimensions: 434 mm (W) × 128 mm (H) × 310 mm (D)  
Weight: 6.7 kg

**REMOTE CONTROL UNIT**

RC-174  
Infrared remote system  
Power supply: 3V DC, Two size "AA" (R6) dry cell batteries  
External dimensions: 96 mm (W) × 175 mm (H) × 25 mm (D)  
Weight: 120 g (includes batteries)

Design and specifications are subject to change without prior notice.

**TROUBLESHOOTING**

1. Have all connections been made PROPERLY?
  2. Have you followed all operational instructions correctly?
  3. Check speaker and the turntable systems for proper operation.
- When your unit does not seem to be operating correctly, first check the items in the following table. If the symptom does not correspond to any of the problems as shown below, turn off the power sources immediately and contact your DENON dealer.

Problem	Cause	Remedy
<b>FM AND AM RECEPTION</b>		
Radio program can not be received.	<ul style="list-style-type: none"> <li>• Antenna connection is wrong.</li> <li>• A signal strength is weak.</li> </ul>	<ul style="list-style-type: none"> <li>• Check the connection.</li> <li>• Check the antenna installation.</li> </ul>
Noise is reproduced.	<ul style="list-style-type: none"> <li>• A signal strength is weak.</li> <li>• Automobile ignition noise interferes with reception.</li> <li>• Other electrical equipment interferes with reception.</li> </ul>	<ul style="list-style-type: none"> <li>• Install an outdoor antenna.</li> <li>• Keep the antenna away from the street.</li> <li>• Keep the equipment away from this set, or turn off the power of the other equipment.</li> </ul>
The preset frequencies are erased.	<ul style="list-style-type: none"> <li>• The memory back-up turn (about 1 month) passed.</li> </ul>	<ul style="list-style-type: none"> <li>• Preset again.</li> </ul>
In automatic tuning, the frequency doesn't stop at the radio station.	<ul style="list-style-type: none"> <li>• A signal strength is weak.</li> </ul>	<ul style="list-style-type: none"> <li>• Use manual tuning.</li> </ul>
In automatic tuning, it stops at the one step lower or higher frequency than the radio station.	<ul style="list-style-type: none"> <li>• Noise or strong signal strength is received.</li> </ul>	<ul style="list-style-type: none"> <li>• Use manual tuning for optimum reception.</li> </ul>
<b>PLAYBACK OF THE AUDIO EQUIPMENTS</b>		
No sound is produced with power on.	<ul style="list-style-type: none"> <li>• Input and speaker cords connection are wrong.</li> <li>• Speaker switch is off.</li> <li>• The INPUT SELECTOR buttons are in wrong position.</li> <li>• The protective circuit is operating.</li> <li>• The fuse has blown out.</li> </ul>	<ul style="list-style-type: none"> <li>• Check the connection.</li> <li>• Turn on speaker switch.</li> <li>• Check these position.</li> <li>• Turn the power off once, check the connectors to the speakers, then turn the power on again.</li> <li>• Ask your dealer, or the nearest DENON representative.</li> </ul>
Audible hum when playing records.	<ul style="list-style-type: none"> <li>• The input and grounding cords connection of the turntable are wrong.</li> <li>• The cords connection of the cartridge are wrong.</li> <li>• The interference from the nearby TV or radio transmission antenna</li> </ul>	<ul style="list-style-type: none"> <li>• Check the connection.</li> <li>• Check the connection.</li> <li>• Ask your dealer, or the nearest DENON representative.</li> </ul>
Howling is produced when the volume control is turned up too high while playing records.	<ul style="list-style-type: none"> <li>• The vibrations and sounds transmit from the speakers to the turntable.</li> </ul>	<ul style="list-style-type: none"> <li>• Insulate the vibrations, or keep the speakers away from the turntable.</li> </ul>
Crackling noise is produced when playing records.	<ul style="list-style-type: none"> <li>• The record is stained with dust.</li> <li>• The stylus tip of the cartridge is stained with the dust.</li> <li>• The cartridge is defective.</li> </ul>	<ul style="list-style-type: none"> <li>• Clean the record.</li> <li>• Clean the stylus tip.</li> <li>• Try the other cartridge.</li> </ul>

# DISASSEMBLY

(To reassemble reverse disassembly)

## 1. Top Cover

- (1) Remove 4 screws ①.
- (2) Remove 3 screws ②.

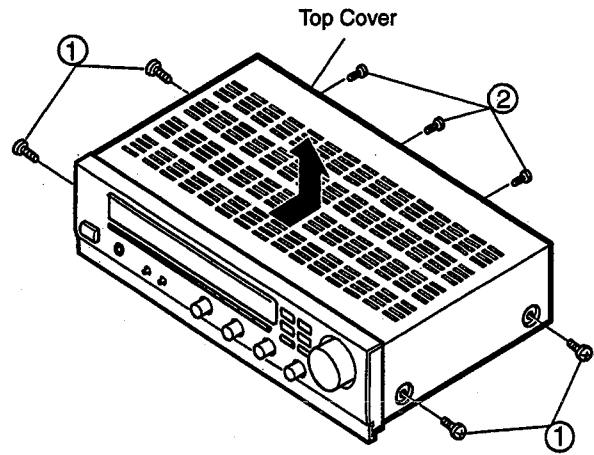

## 2. Front Panel

- (1) Pull out Volume knob ③.
- (2) Remove nut ④.
- (3) Remove 4 screws ⑤ and undo hooks at 3 places.

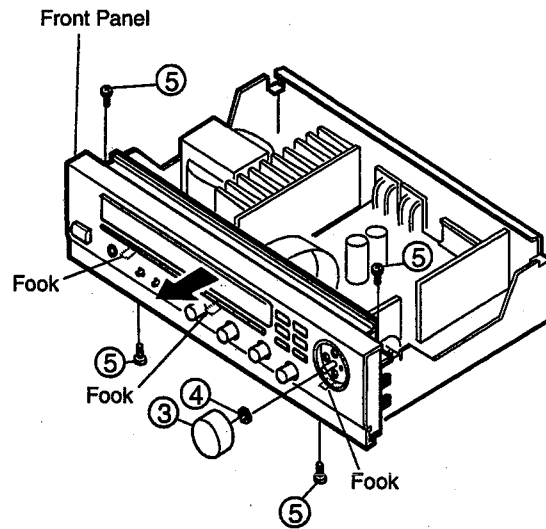

## 3. Rear Panel

- (1) Remove 2 screws ⑥ and 12 fixing screws ⑦.
- (2) Remove hooks at 3 places in arrow direction (↑).

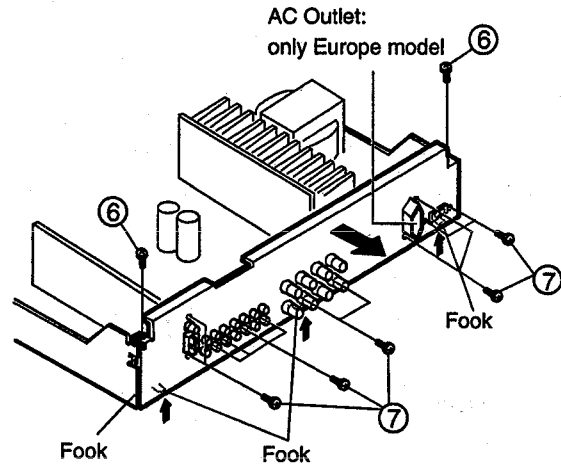



## METHOD OF ADJUSTMENTS

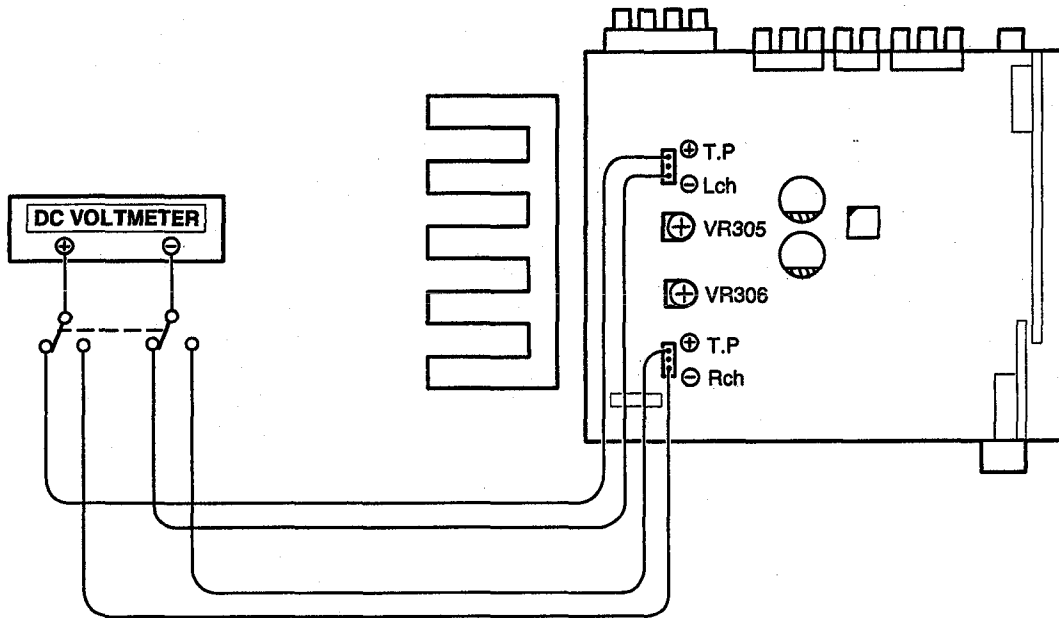

### IDLING CURRENT

- (1) Set controls as follows.
  - POWER Switch → off (■)
  - VOLUME Control → 0 (min.)
  - SPEAKERS → off (■)
  - Temperature → 15°C ~ 30°C (59°F ~ 86°F)
  - VR305 and VR306 of the 1U-2817 (Main Unit) → MIN. (⤵)
- (2) Connect DC Voltmeter to the T.P Lch and T.P Rch of the 1U-2817.
- (3) Turn the Power Switch on and rotate VR305 clockwise so that the DC Voltmeter reads 3 mV  $\pm$ 0.2 mV DC at the T.P Lch. Follow the same procedure to VR306 for T.P Rch.
- (4) Warm up for three minutes, then readjust VR305 and VR306 so that the DC Voltmeter reads 3 mV  $\pm$ 0.5 mV DC.
- (5) Warm up for 10 minutes, then readjust VR 305 and VR306 so that the DC Voltmeter reads 2.7 mV  $\pm$ 0.5 mV DC.

# CONNECTINON DIAGRAM OF MEASURING INSTRUMENTS

## ● FM SECTION

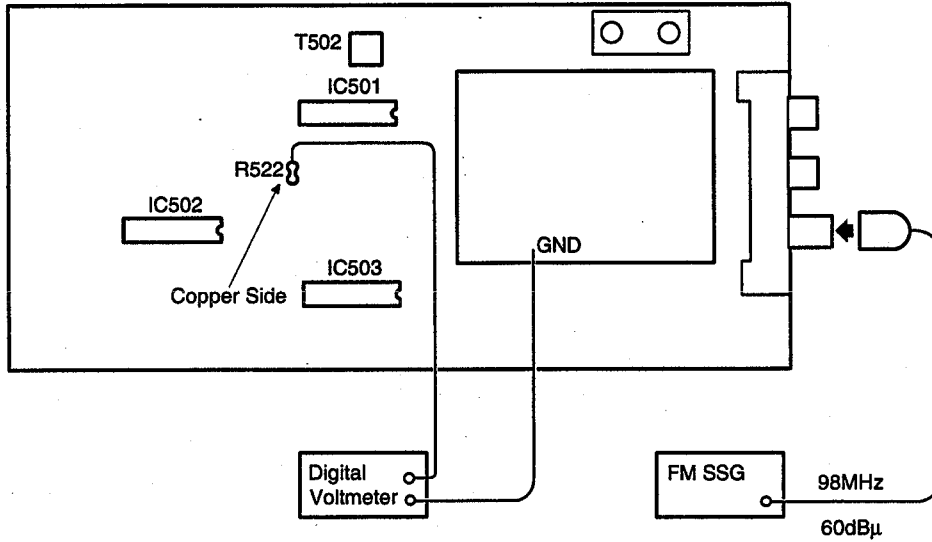

Adjust T502, Potential difference across R522 should be within 50mV.

# BLOCK/LEVEL DIAGRAM

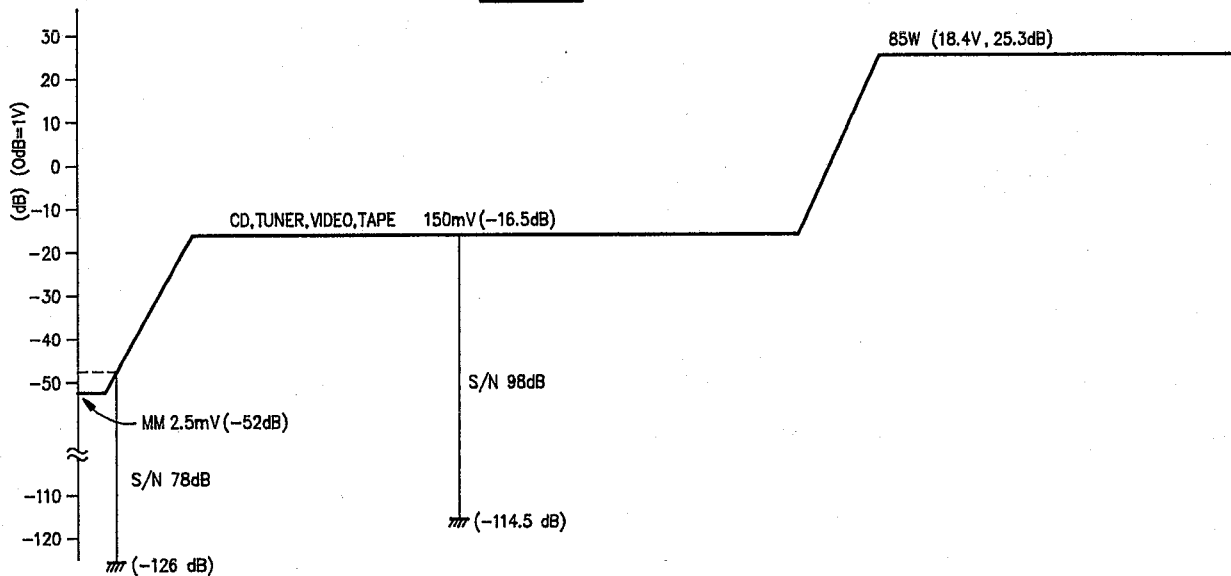
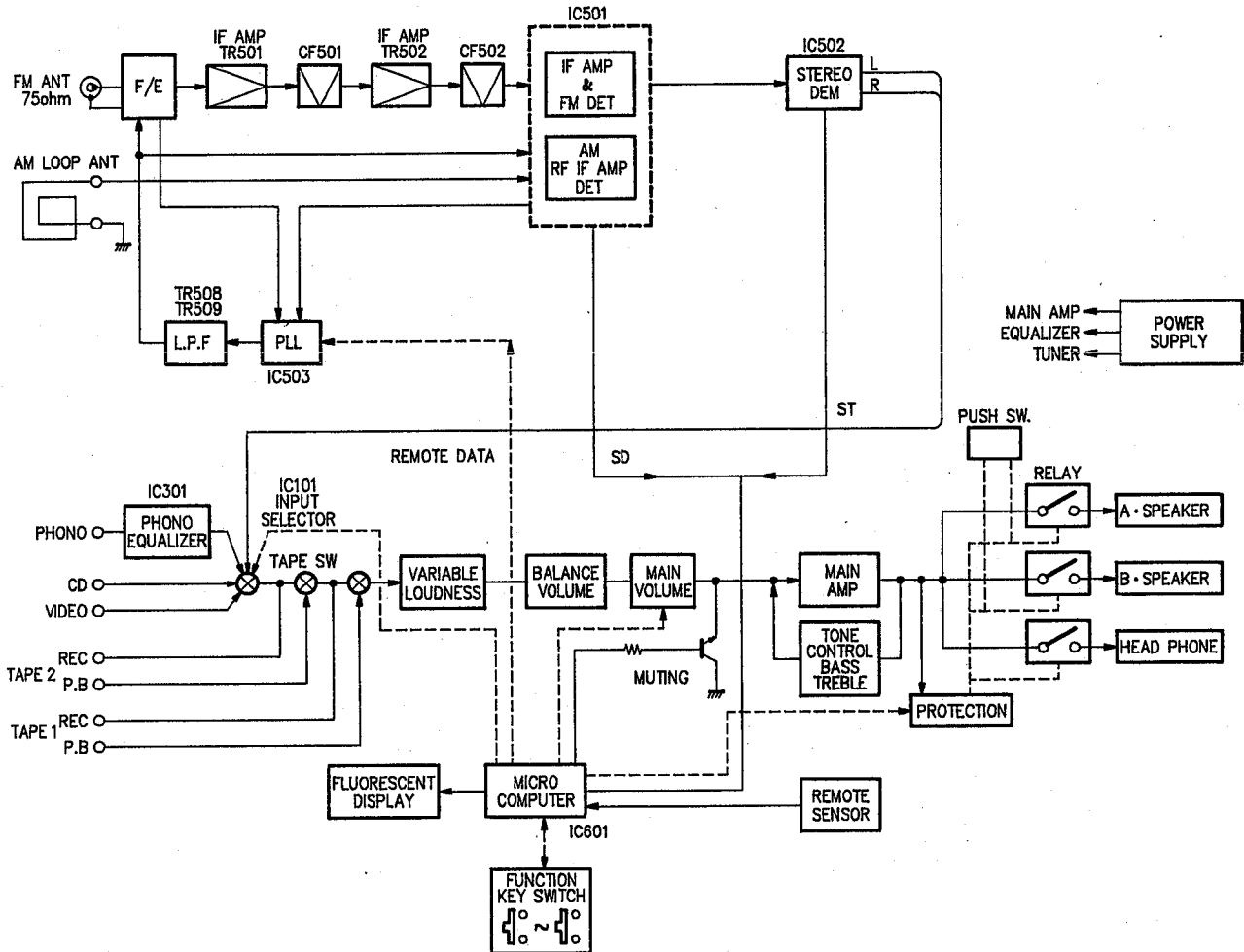

## NOTE FOR PARTS LIST

- Part indicated with the mark "◎" are not always in stock and possibly to take a long period of time for supplying, or in some case supplying of part may be refused.
- When ordering of part, clearly indicate "1" and "1" (l) to avoid mis-supplying.
- Ordering part without stating its part number can not be supplied.
- Part indicated with the mark "★" is not illustrated in the exploded view.
- Not including Carbon Film ±5%, 1/4W Type in the P.W.Board parts list. (Refer to the Schematic Diagram for those parts.)

**WARNING:**

Parts marked with this symbol  have critical characteristics.  
Use ONLY replacement parts recommended by the manufacturer.

● **Resistors**

Ex: RN 14K 2E 182 G FR  
 Type Shape and performance Power Resistance Allowable error Others

RD : Carbon	2B : 1/8W	F : ±1%	P : Pulse-resistant type
RC : Composition	2E : 1/4W	G : ±2%	NL : Low noise type
RS : Metal oxide film	2H : 1/2W	J : ±5%	NB : Non-burning type
RW : Winding	3A : 1W	K : ±10%	FR : Fuse-resistor
RN : Metal film	3D : 2W	M : ±20%	F : Lead wire forming
RK : Metal mixture	3F : 3W		
	3H : 5W		

• **Resistance**

1 8 2 ⇒ 1800 ohm = 1.8 kohm  
 Indicates number of zeros after effective number.  
 2-digit effective number.

• Units: ohm

1 R 2 ⇒ 1.2 ohm  
 1-digit effective number.  
 2-digit effective number, decimal point indicated by R.

• Units: ohm

● **Capacitors**

Ex: CE 04W 1H 2R2 M BP  
 Type Shape and performance Dielectric strength Capacity Allowable error Others

CE : Aluminum foil electrolytic	0J : 6.3V	F : ±1%	HS : High stability type
CA : Aluminum solid electrolytic	1A : 10V	G : ±2%	BP : Non-polar type
CS : Tantalum electrolytic	1C : 16V	J : ±5%	HR : Ripple-resistant type
CQ : Film	1E : 25V	K : ±10%	DL : For charge and discharge
CK : Ceramic	1V : 35V	M : ±20%	HF : For assuring high frequency
CC : Ceramic	1H : 50V	Z : +80%	U : UL part
CP : Oil	2A : 100V	-20%	C : CSA part
CM : Mica	2B : 125V	P : +100%	W : UL-CSA type
CF : Metallized	2C : 160V	-0%	F : Lead wire forming
CH : Metallized	2D : 200V	C : ±0.25pF	
	2E : 250V	D : ±0.5pF	
	2H : 500V	= : Others	
	2J : 630V		

• **Capacity (electrolyte only)**

2 2 2 ⇒ 2200µF  
 Indicates number of zeros after effective number.  
 2-digit effective number.

• Units: µF.

2 R 2 ⇒ 2.2µF  
 1-digit effective number.  
 2-digit effective number, decimal point indicated by R.

• Units: µF.

• **Capacity (except electrolyte)**

2 2 2 ⇒ 2200pF = 0.0022µF  
 (More than 2) — Indicates number of zeros after effective number.  
 2-digit effective number.

• Units: µF.

2 2 1 ⇒ 220pF  
 (0 or 1) — Indicates number of zeros after effective number.  
 2-digit effective number.

• Units: pF.

• When the dielectric strength is indicated in AC, "AC" is included after the dielectric strength value.

# PRINTED WIRING BOARD PARTS LIST

## 1U-2817E MAIN UNIT ASS'Y

Ref. No.	Part No.	Part Name	Remarks	Ref. No.	Part No.	Part Name	Remarks
<b>SEMICONDUCTORS GROUP</b>				<b>RESISTORS GROUP</b>			
IC101	262 1227 008	IC LC7821		D403	276 0553 905	Diode 1SR35-200A	
IC301	263 0615 902	IC BA15218F		D405-410	276 0553 905	Diode 1SR35-200A	
IC401	263 1010 001	IC BA178M06		D411,412	276 0616 907	Diode 1SS252	
IC701	263 1032 908	IC NJM2082MD		D451-453	276 0616 907	Diode 1SS252	
IC801	262 1701 906	IC :SAA6579T		D651	276 0616 907	Diode 1SS252	
IC802	262 1929 908	IC LC7074M		ZD101	276 0634 905	Zener diode MTZJ3.3A	
TR251	274 0158 003	Transistor 2SD2004(P)		ZD251,252	276 0637 902	Zener diode MTZJ6.2A	
TR252	272 0115 008	Transistor 2SB1328(P)		ZD401	276 0634 905	Zener diode MTZJ3.3A	
TR253	273 0432 904	Transistor 2SC2389S(S/E)		ZD402	276 0633 906	Zener diode MTZJ6.8C	
TR254	271 0280 901	Transistor 2SA933S(S)		ZD403	276 0632 907	Zener diode MTZJ27D	
TR255	273 0432 984	Transistor 2SC2389S(S/E)		ZD451-453	276 0635 904	Zener diode MTZJ7.5C	
TR256	271 0280 901	Transistor 2SA1038S(S/E)		SC451	279 0016 904	Thyristor SF0R1A42	
TR257	273 0432 904	Transistor 2SC2389S(S/E)		<b>RESISTORS GROUP</b>			
TR301,302	269 0107 900	Transistor RN1241(A/B)	Built in resistor	VR305,306	211 6093 909	Semi fixed resistor 6.8Kohm	V06PB682
TR303,304	273 0235 923	Transistor 2SC1841(E/F)		R001,002	247 0018 905	Carbon chip 0ohm 1/10W	RM73B-0R0K
TR305-308	271 0131 924	Transistor 2SA988(E/F)		R101-108	247 0014 967	Carbon chip 1Mohm 1/10W	RM73B-105J
TR309,310	273 0235 923	Transistor 2SC1841(E/F)		R109-116	247 0006 962	Carbon chip 470ohm 1/10W	RM73B-471J
TR315,316	273 0198 905	Transistor 2SC1815(Y)		R117	247 0014 925	Carbon chip 680kohm 1/10W	RM73B-684J
TR317,318	274 0060 900	Transistor 2SD667A(C)		R131-134	247 0014 967	Carbon chip 1Mohm 1/10W	RM73B-105J
TR319,320	272 0053 908	Transistor 2SB647A(C)		R135-138	247 0006 962	Carbon chip 470ohm 1/10W	RM73B-471J
TR321,322	273 0389 002	Transistor 2SC3855(O/PHY)		△R201,202	244 2052 931	Metal oxide film 390ohm 1W	RS14B3A391JNBS(S)
TR323,324	271 0240 006	Transistor 2SA1491(O/PHY)		△R259,260	241 2387 940	Carbon 4.7ohm 1/4W	RD14B2E4R7JNBS
TR325,326	273 0235 923	Transistor 2SC1841(E/F)		R263	247 0009 985	Carbon chip 10kohm 1/10W	RM73B-103J
TR401	273 0384 900	Transistor 2SC2412K(S)		R264	247 0012 927	Carbon chip 100kohm 1/10W	RM73B-104J
TR402	269 0048 904	Transistor DTC143EK	Built in resistor	R305,306	247 0012 969	Carbon chip 150kohm 1/10W	RM73B-154J
TR403	273 0384 900	Transistor 2SC2412K(S)		R307,308	247 0006 962	Carbon chip 470ohm 1/10W	RM73B-471J
TR404	272 0131 901	Transistor 2SB1041(R)		R309,310	247 0009 914	Carbon chip 5.1kohm 1/10W	RM73B-512J
TR451	271 0131 924	Transistor 2SA988(E/F)		△R311,312	241 2379 932	Carbon 620ohm 1/4W	RD14B2E621JNBS
TR452	273 0432 904	Transistor 2SC2389S(S/E)		R323,324	247 0005 989	Carbon chip 220kohm 1/10W	RM73B-221J
TR453	269 0054 901	Transistor DTC144EK	Built in resistor	△R329,330	241 2378 926	Carbon 220ohm 1/4W	RD14B2E221JNBS
TR454	273 0384 900	Transistor 2SC2412K(S)		△R331-334	244 2043 982	Metal oxide film 0.22ohm 1W	RS14B3AR22JNBS(S)
TR455	273 0388 906	Transistor 2SC1740S(E)		R335,336	247 0013 984	Carbon chip 470kohm 1/10W	RM73B-474J
TR456	271 0192 905	Transistor 2SA933S(S)		R351,352	247 0012 901	Carbon chip 82kohm 1/10W	RM73B-823J
TR457	273 0388 906	Transistor 2SC1740S(E)		R353,354	247 0012 969	Carbon chip 150kohm 1/10W	RM73B-154J
TR458,459	273 0432 904	Transistor 2SC2389S(S/E)		R355,356	247 0004 922	Carbon chip 47ohm 1/10W	RM73B-470J
TR460	273 0384 900	Transistor 2SC2412K(S)		R357	247 0009 901	Carbon chip 4.7kohm 1/10W	RM73B-472J
TR471	269 0083 901	Transistor DTA114EK	Built in resistor	R358	247 0011 944	Carbon chip 47kohm 1/10W	RM73B-473J
TR473	269 0054 901	Transistor DTC144EK	Built in resistor	△R361-364	244 2043 982	Metal oxide film 0.22ohm 1W	RS14B3AR22JNBS(S)
D251	276 0667 008	Bridge diode 4D4B41		△R385,386	241 2379 932	Carbon 620ohm 1/4W	RD14B2E621JNBS
D252	276 0553 905	Diode 1SR35-200A		△R387-390	241 2377 889	Carbon 150ohm 1/4W	RD14B2E151JNBS
D253,254	276 0616 907	Diode 1SS252		△R391,392	244 2043 987	Metal oxide film 10ohm 1W	RS14B3A100JNBS(S)
D303-306	276 0619 904	Diode 1S2471					
D307-312	276 0616 907	Diode 1SS252					
D401,402	276 0616 907	Diode 1SS252					

Ref. No.	Part No.	Part Name	Remarks
R401	247 0013 900	Carbon chip 220kohm 1/10W	RM73B--224J
R402	247 0009 985	Carbon chip 10kohm 1/10W	RM73B--103J
R403	247 0009 901	Carbon chip 4.7kohm 1/10W	RM73B--472J
R404,405	247 0007 945	Carbon chip 1kohm 1/10W	RM73B--102J
R406	247 0009 985	Carbon chip 10kohm 1/10W	RM73B--103J
R407	247 0010 958	Carbon chip 20kohm 1/10W	RM73B--203J
R408	247 0009 985	Carbon chip 10kohm 1/10W	RM73B--103J
R409	247 0007 945	Carbon chip 1kohm 1/10W	RM73B--102J
R410	247 0009 901	Carbon chip 4.7kohm 1/10W	RM73B--472J
△R411	244 2051 987	Metal oxide film 4.7kohm 1W	RS14B3A4R7JNBS(S)
△R412	241 2377 947	Carbon 100ohm 1/4W	RD14B2E101JNBS
△R415	241 2387 908	Carbon 1ohm 1/4W	RD14B2E010JNBS
△R451,452	244 2052 902	Metal oxide film 2.7kohm 1W	RS14B3A272JNBS(S)
△R453	244 2051 990	Metal oxide film 4.7kohm 1W	RS14B3A472JNBS(S)
R460	247 0011 944	Carbon chip 47kohm 1/10W	RM73B--473J
△R465,466	244 2052 902	Metal oxide film 2.7kohm 1W	RS14B3A272JNBS(S)
△R467	244 2050 991	Metal oxide film 6.8kohm 1W	RS14B3A682JNBS(S)
R468	244 2052 957	Metal oxide film 5.6kohm 1W	RS14B3A562JNBS(S)
R475	247 0010 929	Carbon chip 15kohm 1/10W	RM73B--153J
R701,702	247 0009 901	Carbon chip 4.7kohm 1/10W	RM73B--472J
R703,704	247 0012 969	Carbon chip 150kohm 1/10W	RM73B--154J
R705,706	247 0011 986	Carbon chip 68kohm 1/10W	RM73B--683J
R707,708	247 0004 922	Carbon chip 47ohm 1/10W	RM73B--470J
R709,710	247 0005 992	Carbon chip 240ohm 1/10W	RM73B--241J
R711,712	247 0012 956	Carbon chip 130kohm 1/10W	RM73B--134J
R713,714	247 0009 998	Carbon chip 11kohm 1/10W	RM73B--113J
R715,716	247 0003 949	Carbon chip 22ohm 1/10W	RM73B--220J
R717,718	247 0005 905	Carbon chip 100ohm 1/10W	RM73B--101J
R719,720	247 0012 927	Carbon chip 100kohm 1/10W	RM73B--104J
<b>CAPACITORS GROUP</b>			
C101-108	257 0004 903	Ceramic chip 56pF/50V	CC73SL1H560J
C109,110	253 1179 945	Ceramic 220pF/50V	CK45B1H221KT
C111	257 0002 921	Ceramic chip 10pF/50V	CC73SL1H100D
C112,113	257 0012 982	Ceramic chip 0.022μF/50V	CK73F1H223Z
C124,125	257 0012 982	Ceramic chip 0.022μF/50V	CK73F1H223Z
C127	257 0012 982	Ceramic chip 0.022μF/50V	CK73F1H223Z
C131-134	257 0004 903	Ceramic chip 56pF/50V	CC73SL1H560J
C201-204	255 1265 907	Film 6800pF/50V	CQ93M1H682J(B)
C205,206	257 0006 985	Ceramic chip 820pF/50V	CC73SL1H821J
C251-254	254 4258 918	Electrolytic 10μF/35V	CE04W1V100M
△C257,258	254 6201 002	Electrolytic 7200μF/63V	CE04W--722MC(DL)
C259	253 1181 904	Ceramic 0.01μF/50V	CK45F1H103Z
C307,308	257 0006 927	Ceramic chip 470pF/50V	CC73SL1H471J
C311-314	253 4536 909	Ceramic 10pF/50V	CC45SL1H100D
C323,324	254 4260 948	Electrolytic 1μF/50V	CE04W1H010M
C325,326	255 1265 936	Film 0.01μF/50V	CQ93M1H103J(B)

Ref. No.	Part No.	Part Name	Remarks
C331,332	254 4260 948	Electrolytic 1μF/50V	CE04W1H010M
C333,334	254 4260 922	Electrolytic 0.33μF/50V	CE04W1HR33M
C335,336	257 0004 961	Ceramic chip 100pF/50V	CC73SL1H101J
C337,338	257 0002 992	Ceramic chip 20pF/50V	CC73SL1H200J
C339,340	254 4254 925	Electrolytic 33μF/16V	CE04W1C330M
C341,342	257 0004 961	Ceramic chip 100pF/50V	CC73SL1H101J
△C353,354	255 1034 979	Metalized 0.1μF/50V	CF93A1H104J
C355,356	255 1265 978	Film 0.022F/50V	CQ93M1H223J(B)
C357	254 4260 948	Electrolytic 1mF/50V	CE04W1H010M
C358	253 9030 963	Ceramic 0.01μF/25V	CK45-1E103K
C359,360	254 4260 948	Electrolytic 1μF/50V	CE04W1H010M
C401	254 4258 905	Electrolytic 4.7μF/35V	CE04W1V4R7M
C402	257 0012 966	Ceramic chip 0.01μF/50V	CK73F1H103Z
C403	254 4260 948	Electrolytic 1μF/50V	CE04W1H010M
C404,405	253 1181 904	Ceramic 0.01μF/50V	CK45F1H103Z
C406	259 0007 702	For back up 8200μF	SB CAP--822=C
C407	254 4254 909	Electrolytic 10μF/16V	CE04W1C100M
C408	254 4403 734	Electrolytic 4700μF/25V	CE04W1E472MC(SMG)
C409	254 4261 921	Electrolytic 100μF/50V	CE04W1H101M
C410	254 4260 948	Electrolytic 1μF/50V	CE04W1H010M
C451	254 4260 980	Electrolytic 10μF/50V	CE04W1H100M
C452	254 4254 925	Electrolytic 33μF/16V	CE04W1C330M
C453	254 4250 945	Electrolytic 330μF/6.3V	CE04W0J331M
C456	255 1265 936	Film 0.01μF/50V	CQ93M1H103J(B)
C459,460	253 1151 905	Ceramic 4700pF/500V	CK45E2H472P
△C461	255 1042 903	Metalized 0.1μF/250V	CF93A2E104K
C462	254 4254 938	Electrolytic 47μF/16V	CE04W1C470M
C549	254 4252 927	Electrolytic 47μF/10V	CE04W1A470M
C701,702	257 0003 988	Ceramic chip 47pF/50V	CC73SL1H470J
C703,704	257 0005 944	Ceramic chip 220pF/50V	CC73SL1H221J
C705,706	254 4254 909	Electrolytic 10μF/16V	CE04W1C100M
C709,710	254 4250 929	Electrolytic 100μF/6.3V	CE04W0J101M
C711,712	255 4199 999	Film 0.024μF/50V	CQ92M1H243J(MRZ)
C713,714	255 1265 907	Film 6800pF/50V	CQ93M1H682J(B)
C715,716	254 4254 909	Electrolytic 10μF/16V	CE04W1C100M
C717,718	253 1181 904	Ceramic 0.01μF/50V	CK45F1H103Z
C724	254 4260 948	Electrolytic 1μF/50V	CE04W1H010M
C725	257 0012 982	Ceramic chip 0.022μF/50V	CK73F1H223Z
C801,802	257 0016 962	Ceramic chip 27pF/50V	CC73CH1H270J
C803-805	254 4250 916	Electrolytic 47μF/6.3V	CE04W0J470M
C807,808	257 0003 933	Ceramic chip 30pF/50V	CC73SL1H300J
C809	257 0012 966	Ceramic chip 0.01μF/50V	CK73F1H103Z
C810	254 4250 916	Electrolytic 47μF/6.3V	CE04W0J470M
C811	257 0006 943	Ceramic chip 560pF/50V	CC73SL1H561J

1U-2818 TUNER UNIT ASS'Y

Ref. No.	Part No.	Part Name	Remarks	Ref. No.	Part No.	Part Name	Remarks
<b>OTHERS PARTS GROUP</b>				<b>SEMICONDUCTORS GROUP</b>			
CB29D	205 0990 045	29P FFC connector base		IC501	263 0891 001	IC LA1265(S)	
CB6A,6C	205 0918 001	6P bottom socket		IC502	263 0439 007	IC LA3401	
CB8A	205 0918 014	8P bottom socket		IC503	263 0791 907	IC LM7001M	
CB8B,8C	205 0806 090	8P connector base (9115)		IC504	263 0794 001	IC NJM78M12FA(S)	
CN3C	203 2377 000	2P DA-DA connector cord		TR501	275 0074 902	Transistor 2SK211(Y/GR)	
CN7A	205 0653 078	7P VH connector base		TR502	273 0438 908	Transistor 2SC2413K (Q)	
L391,392	235 0104 007	Inductor(1MHz)		TR503	269 0157 905	Transistor DTB123EK	Built in resistor
L701,702	235 9003 002	FTZ choke coil		TR504	269 0083 901	Transistor DTA114EK	Built in resistor
RL451,452	214 0167 005	Relay(G5Z-2A)		TR505,506	269 0054 901	Transistor DTC144EK	Built in resistor
RL453	214 0127 003	Relay(RY-12W)		TR507	271 0279 909	Transistor 2SA1515(R)	
TH451	279 0034 067	Posistor	PTH9M04BB222TS2F333	TR508	275 0075 901	Transistor 2SK209(Y/GR)	
TP001,002	205 0190 036	3P NH Connector base	TEST POINT	TR509	273 0403 904	Transistor 2SC2712(Y/GR)	
XL601	399 0178 007	Crystal	4.332MHz	D501	276 0559 909	Diode DAP202K	
XT801	399 0041 901	Resonator	CSA4.00MG				
	205 0484 001	8P speaker terminal	Europe model	<b>RESISTORS GROUP (Not included carbon film ±5% 1/4W)</b>			
	203 0475 072	1P contact Ass'y		R001~016	247 0018 905	Chip 0ohm 1/10W	RM73B--0R0K
	205 0472 013	8P speaker terminal	U.K model	R501	247 0004 906	Chip 39ohm 1/10W	RM73B--390J
	204 8485 009	4P pin jack(S-GND)		R502	247 0007 945	Chip 1kohm 1/10W	RM73B--102J
	204 8486 008	6P pin jack(S-GND)		R503	247 0009 985	Chip 10kohm 1/10W	RM73B--103J
				R504	247 0009 927	Chip 5.6kohm 1/10W	RM73B--562J
				R505	247 0006 920	Chip 330ohm 1/10W	RM73B--331J
				R506	247 0009 901	Chip 4.7kohm 1/10W	RM73B--472J
				R507	247 0005 989	Chip 220ohm 1/10W	RM73B--221J
				R508,509	247 0006 920	Chip 330ohm 1/10W	RM73B--331J
				R510	247 0006 988	Chip 560ohm 1/10W	RM73B--561J
				R511	247 0012 927	Chip 100kohm 1/10W	RM73B--104J
				R512	247 0009 914	Chip 5.1kohm 1/10W	RM73B--512J
				R513	247 0005 905	Chip 100ohm 1/10W	RM73B--101J
				R514	247 0008 986	Chip 3.9kohm 1/10W	RM73B--392J
				R515	247 0006 946	Chip 390ohm 1/10W	RM73B--391J
				R516	247 0005 947	Chip 150ohm 1/0W	RM73B--151J
				R517	247 0009 985	Chip 10kohm 1/10W	RM73B--103J
				R518	247 0018 905	Chip 0ohm 1/10W	RM73B--0R0K
				R519	247 0009 901	Chip 4.7kohm 1/10W	RM73B--472J
				R520	247 0004 980	Chip 82ohm 1/10W	RM73B--820J
				R521	247 0008 944	Chip 2.7kohm 1/10W	RM73B--272J
				R522	247 0011 902	Chip 33kohm 1/10W	RM73B--333J
				R523~525	247 0009 985	Chip 10kohm 1/10W	RM73B--103J
				R526	247 0008 957	Chip 3kohm 1/10W	RM73B--302J
				R527	247 0011 986	Chip 68kohm 1/10W	RM73B--683J
				R528	247 0009 956	Chip 7.5kohm 1/10W	RM73B--752J
				R529	247 0008 960	Chip 3.3kohm 1/10W	RM73B--332J
				R530	247 0012 927	Chip 100kohm 1/10W	RM73B--104J
				R532	247 0009 985	Chip 10kohm 1/10W	RM73B--103J
				R533	247 0007 945	Chip 1kohm 1/10W	RM73B--102J
				R534	247 0011 915	Chip 36kohm 1/10W	RM73B--363J

Ref. No.	Part No.	Part Name	Remarks	Ref. No.	Part No.	Part Name	Remarks
R535	247 0010 974	Chip 24kohm 1/10W	RM73B--243J	<b>OTHERS PARTS GROUP</b>			
R536	247 0012 985	Chip 180kohm 1/10W	RM73B--184J	CF501,502	261 0064 007	Ceramic filter	SFT10.7MS2
R537	247 0012 998	Chip 200kohm 1/10W	RM73B--204J	CF504	261 0101 009	:Ceramic filter	BFU450C4N
R538	247 0012 985	Chip 180kohm 1/10W	RM73B--184J	CN8B,8C	205 0805 091	8P connector socket	
R539	247 0012 998	Chip 200kohm 1/10W	RM73B--204J	FE501	216 0065 006	Front end	
R540,541	247 0008 902	Chip 1.8kohm 1/10W	RM73B--182J	T501	231 1913 004	MW antenna OSC coil	
R542,543	247 0009 901	Chip 4.7kohm 1/10W	RM73B--472J	T502	231 2099 008	FM DET trans	
R544	247 1007 986	Chip 1.5kohm 1/8W	RM73B2B152J	T503	231 3904 008	:AM IFT	
R545	247 0009 985	Chip 10kohm 1/10W	RM73B--103J	T504	232 9010 009	Antibirdie filter	
R546	247 0012 927	Chip 100kohm 1/10W	RM73B--104J	T505,506	232 0085 004	:LPF	
<b>CAPACITORS GROUP</b>				XL502	261 0103 007	:Resonator	CSB456F11
C501-506	257 0012 966	Chip(Ceramic) 0.01μF/50V	CK73F1H103Z	XL503	399 0075 003	Crystal	7.2MHz
C507	257 0002 947	Chip(Ceramic) 12pF/50V	CC73SL1H120J		205 0847 004	3P antenna terminal(PAL/F)	
C508	254 4254 909	Electrolytic 10μF/16V	CE04W1C100M		203 0526 031	1P Contact Ass'y	
C509	257 0004 961	Chip(Ceramic) 100pF/50V	CC73SL1H101J				
C510	257 0012 966	Chip(Ceramic) 0.01μF/50V	CK73F1H103Z				
C511	254 4260 906	Electrolytic 0.1μF/50V	CE04W1H0R1M				
C513	254 3056 917	Electrolytic 1μF/50V (Non-polar)	CE04D1H010MBP				
C514	257 0012 982	Chip(Ceramic) 0.022μF/50V	CK73F1H223Z				
C515,516	257 0002 976	Chip(Ceramic) 16pF/50V	CC73SL1H160J				
C517	254 4254 938	Electrolytic 47μF/16V	CE04W1C470M				
C518,519	257 0012 966	Chip(Ceramic) 0.01μF/50V	CK73F1H103Z				
C520	254 4260 922	Electrolytic 0.33μF/50V	CE04W1HR33M				
C521	257 0012 966	Chip(Ceramic) 0.01μF/50V	CK73F1H103Z				
C522	254 4256 936	Electrolytic 47μF/25V	CE04W1E470M				
C523	254 4260 948	Electrolytic 1μF/50V	CE04W1H010M				
C524	254 4260 964	Electrolytic 3.3μF/50V	CE04W1H3R3M				
C525	257 0012 982	Chip(Ceramic) 0.022μF/50V	CK73F1H223Z				
C526	257 0012 966	Chip(Ceramic) 0.01μF/50V	CK73F1H103Z				
C527	254 4260 948	Electrolytic 1μF/50V	CE04W1H010M				
C528	254 4254 909	Electrolytic 10μF/16V	CE04W1C100M				
C529	257 1013 951	Chip(Ceramic) 0.047μF/25V	CK73F1E473K				
C530	254 4254 912	Electrolytic 22μF/16V	CE04W1C220M				
C531	257 0004 961	Chip(Ceramic) 100pF/50V	CC73SL1H101J				
C532	254 4260 948	Electrolytic 1μF/50V	CE04W1H010M				
C533	254 4260 919	Electrolytic 0.22μF/50V	CE04W1HR22M				
C534	254 4260 948	Electrolytic 1μF/50V	CE04W1H010M				
C535,536	257 0012 966	Chip(Ceramic) 0.01μF/50V	CK73F1H103Z				
C537	254 4254 912	Electrolytic 22μF/16V	CE04W1C220M				
C538	254 4254 938	Electrolytic 47μF/16V	CE04W1C470M				
C539,540	257 0005 960	Chip(Ceramic) 270pF/50V	CC73SL1H271J				
C541	254 4260 951	Electrolytic 2.2μF/50V	CE04W1H2R2M				
C545	253 0012 966	Chip(Ceramic) 0.01μF/50V	CK73F1H103Z				
C548	254 4260 951	Electrolytic 2.2μF/50V	CE04W1H2R2M				
C550,551	254 4260 948	Electrolytic 1μF/50V	CE04W1H010M				
C553,554	257 0012 966	Chip(Ceramic) 0.01μF/50V	CK73F1H103Z				
C555	256 1034 937	Metalized 0.047μF/50V	CF93A1H473J				
C561	257 0012 966	Chip(Ceramic) 0.01μF/50V	CK73F1H103Z				



**KU-9328 DISPLAY UNIT ASS'Y**

Ref. No.	Part No.	Part Name	Remarks
<b>SEMICONDUCTORS GROUP</b>			
IC601	262 2249 001	IC TMP87CM71F-6348	
IC602	263 0905 900	IC BA6208F	
ZD651	276 0654 901	Zener diode DTZ8.2B	
<b>RESISTORS GROUP (Not included carbon film ±5% 1/4W)</b>			
VR301	211 0841 018	Variable 100kohm	V14P22FW104K
VR302	211 0831 002	Variable 100kohm	V1620V25FB104(MG)
VR303	211 0842 017	Variable 250kohm	V14P22FC254K
VR304	211 0843 016	Variable 50kohm	V14P22FC503K
VR307	211 9131 004	Variable 100kohm	V14P22FB104K
R301,302	247 0011 928	Chip 39kohm 1/10W	RM73B-393J
R303,304	247 0009 943	Chip 6.8kohm 1/10W	RM73B-682J
R361,362	247 0011 973	Chip 62kohm 1/10W	RM73B-623J
R363,364	247 0009 998	Chip 11kohm 1/10W	RM73B-113J
R365,366	247 0008 931	Chip 2.4kohm 1/10W	RM73B-242J
R367,368	247 0013 984	Chip 470kohm 1/10W	RM73B-474J
R369,370	247 0010 945	Chip 18kohm 1/10W	RM73B-183J
R371,372	247 0009 943	Chip 6.8kohm 1/10W	RM73B-682J
R373,374	247 0006 917	Chip 300ohm 1/10W	RM73B-301J
R375,376	247 0011 944	Chip 47kohm 1/10W	RM73B-473J
R379,380	247 0009 901	Chip 4.7kohm 1/10W	RM73B-472J
R651	247 1009 900	Chip 4.7kohm 1/8W	RM73B2B472J
R652-657	247 0009 985	Chip 10kohm 1/10W	RM73B-103J
R665	247 0007 945	Chip 1kohm 1/10W	RM73B-102J
R666	247 0005 976	Chip 200ohm 1/10W	RM73B-201J
R667	247 0006 917	Chip 300ohm 1/10W	RM73B-301J
R668	247 0007 945	Chip 1kohm 1/10W	RM73B-102J
R669	247 0005 976	Chip 200ohm 1/10W	RM73B-201J
R670	247 0006 917	Chip 300ohm 1/10W	RM73B-301J
R671	247 0007 945	Chip 1kohm 1/10W	RM73B-102J
R672	247 0005 976	Chip 200ohm 1/10W	RM73B-201J
R673	247 0006 917	Chip 300ohm 1/10W	RM73B-301J
R674	247 0006 975	Chip 510ohm 1/10W	RM73B-511J
R675	247 0007 945	Chip 1kohm 1/10W	RM73B-102J
R676	247 0007 945	Chip 1kohm 1/10W	RM73B-102J
R677	247 0005 976	Chip 200ohm 1/10W	RM73B-201J
R678	247 0006 917	Chip 300ohm 1/10W	RM73B-301J
R679	247 0006 975	Chip 510ohm 1/10W	RM73B-511J
R680	247 0007 945	Chip 1kohm 1/10W	RM73B-102J
R681	247 0009 985	Chip 10kohm 1/10W	RM73B-103J
R682,683	247 0009 985	Chip 10kohm 1/10W	RM73B-103J
R685	247 0008 957	Chip 3kohm 1/10W	RM73B-302J

Ref. No.	Part No.	Part Name	Remarks
<b>CAPACITORS GROUP</b>			
C300	257 0012 966	Chip(Ceramic) 0.01µF/50V	CK73F1H103Z
C301,302	257 0006 943	Ceramic 560pF/50V	CC73SL1H561J
C303,304	255 1265 978	Film 0.022µF/50V	CQ93M1H223J(B)
C361,362	257 0004 961	Ceramic 100pF/50V	CC73SL1H101J
C363,364	255 1265 981	Film 0.027µF/50V	CQ93M1H273J(B)
C365,366	256 1034 982	Metalized 0.12µF/50V	CF93A1H124J
C367,368	255 1264 924	Film 1500pF/50V	CQ93M1H152J(B)
C369,370	255 1265 936	Film 0.01µF/50V	CQ93M1H103J(B)
C651	257 0012 966	Chip(Ceramic) 0.01µF/50V	CK73F1H103Z
C652	254 4300 963	Electrolytic 100µF/6.3V	CE04WQJ101M(SRE)
C653	257 0012 966	Chip(Ceramic) 0.01µF/50V	CK73F1H103Z
C655	254 4299 964	Electrolytic 47µF/16V	CE04W1C470M(SRE)
C657	257 0012 982	Chip(Ceramic) 0.022µF/50V	CK73F1H223Z
C666	257 0004 961	Ceramic 100pF/50V	CC73SL1H101J
<b>OTHERS PARTS GROUP</b>			
CB8D	205 0919 026	8P JQ socket(Side)	
CN29D	205 0990 045	29P FFC connector base	
CN6A,6C	205 0917 002	6P bottom plug	
CN8A	205 0917 015	8P bottom plug	
CN8D	205 0408 045	8P JQ socket	
FL401	393 4155 002	FL tube	FIP14AM7R
JK201	204 8354 017	Head phone jack	Black model
JK201	204 8355 003	Head phone jack	Gold model
RM601	499 0150 008	Remote sensor	SBX1610-52
SW302,303	212 1140 009	Push switch(ESB6440)	
SW601-617	212 5604 910	Tact switch	
XL651	399 0261 901	Resonator	DCRH4.00M
	414 0740 006	Shield plate	

**1U-2915 POWER UNIT ASS'Y**

Ref. No.	Part No.	Part Name	Remarks
<b>CAPACITORS GROUP</b>			
△C411	253 8014 702	Ceramic 0.01µF/400V AC	CK45F2GA103MC
<b>OTHERS PARTS GROUP CK45=1E103K</b>			
△AC401	203 3961 004	1P AC outlet	Except to U.K.
△CN2A	203 2349 009	2P Inlet	
CN3A	205 0581 001	2P VH connector base	
△F401	206 1075 030	Fuse(2.0A)	
△F402	206 1075 001	Fuse(1A)	Except to U.K.
△SW401	212 1031 008	Power switch(TV-5)	
	415 0299 000	Condenser cover	
	202 0040 909	Fuse clip	

PRINTED WIRING BOARD PATTERNS

1

2

3

4

5

6

7

8

1U-2817 MAIN UNIT ASS'Y

1U-2915 POWER UNIT ASS'Y

A

B

C

D

E

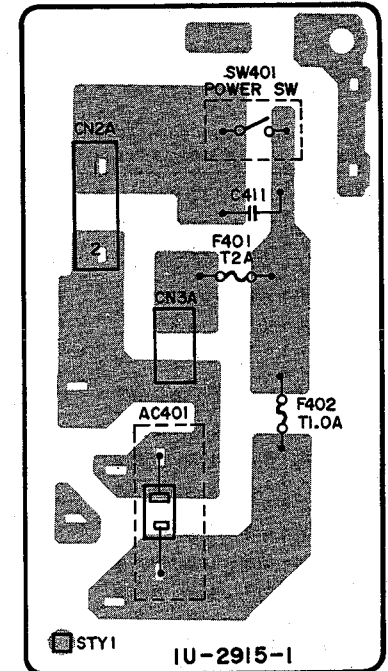
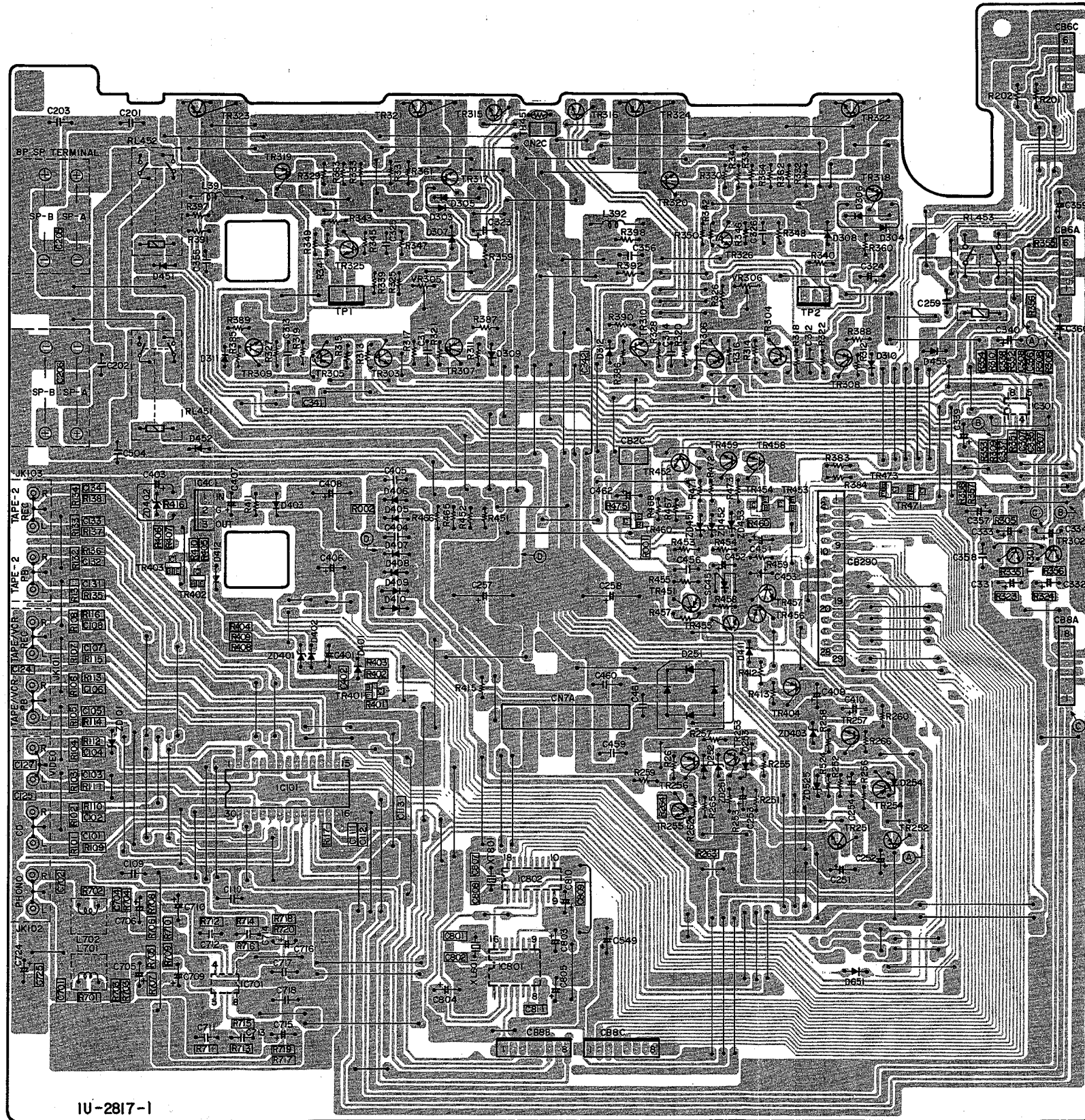



1 2 3 4 5 6 7 8

KU-9328 DISPLAY UNIT ASS'Y

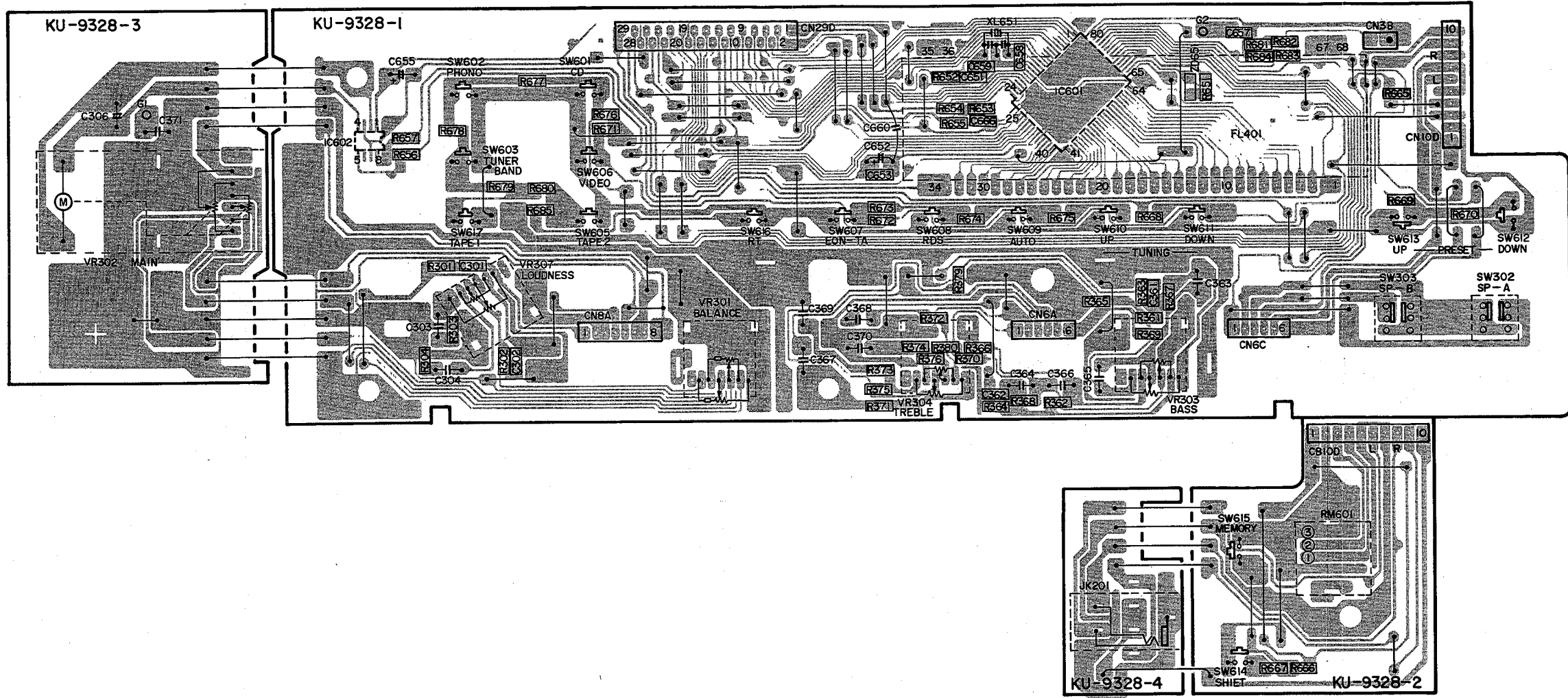

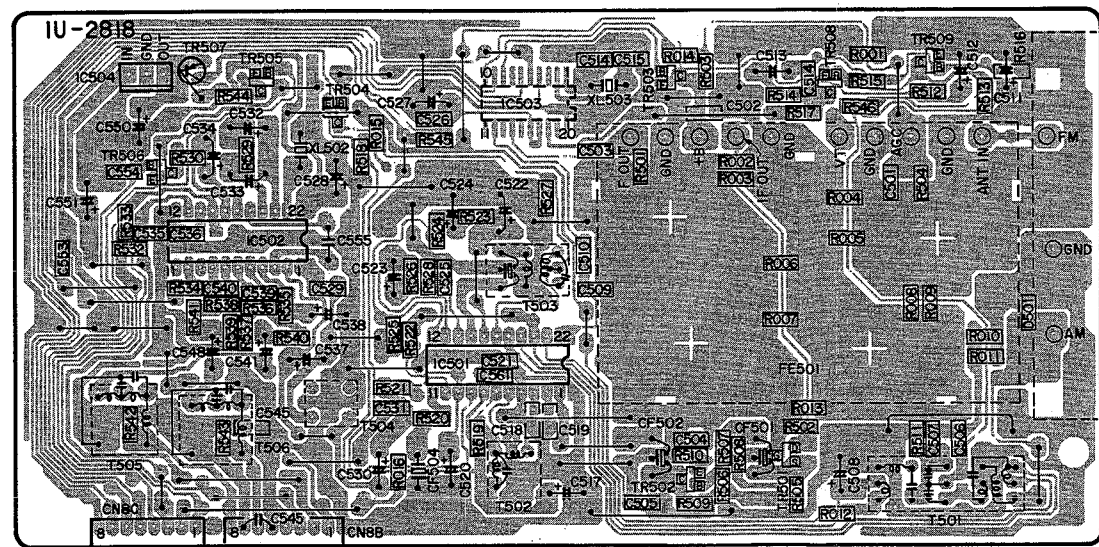

IU-2818 TUNER UNIT ASS'Y

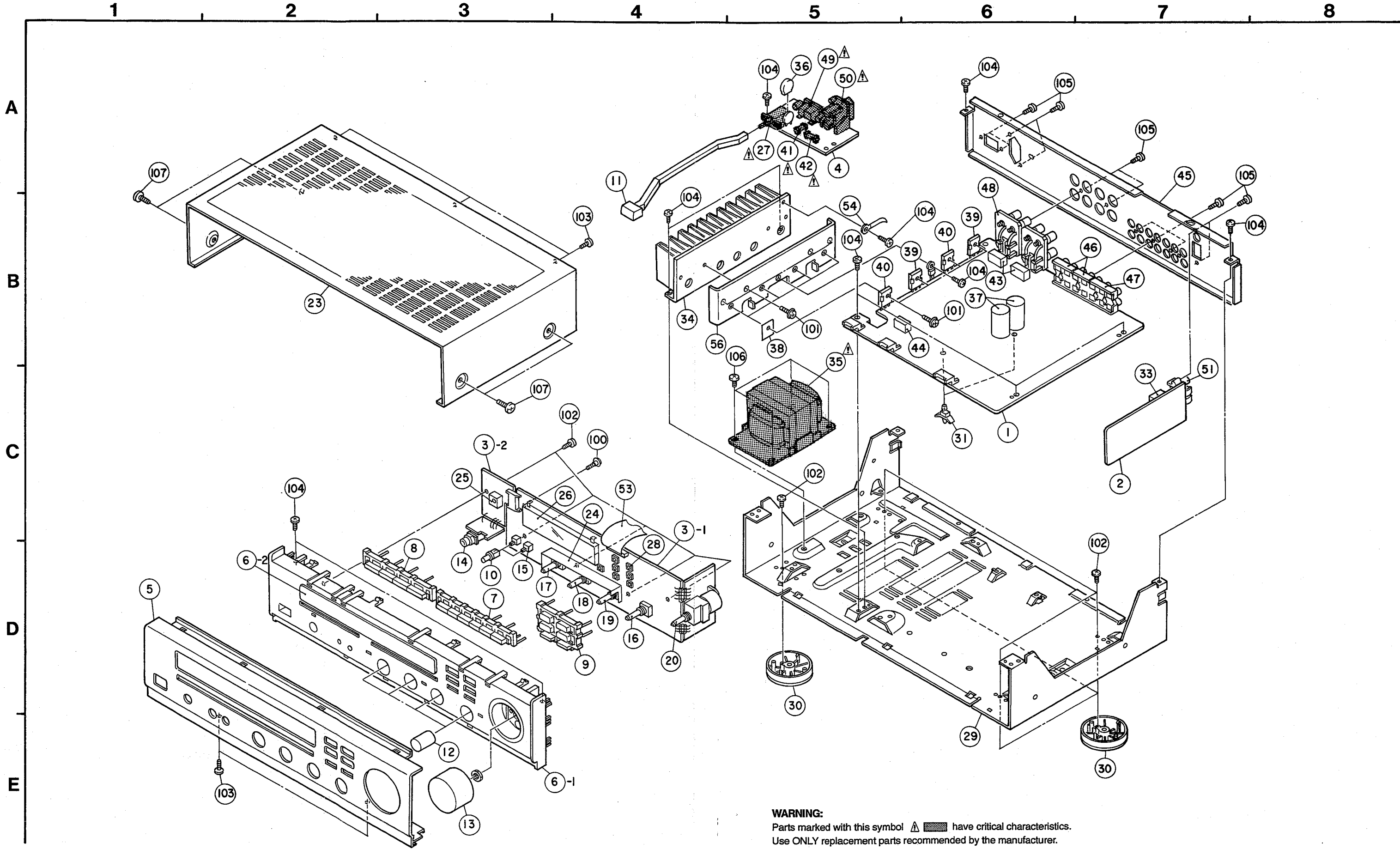

A  
B  
C  
D  
E

# EXPLODED VIEW OF CHASSIS AND CABINET



**WARNING:**  
Parts marked with this symbol  have critical characteristics.  
Use ONLY replacement parts recommended by the manufacturer.

**PARTS LIST EXPLODED VIEW**

\* Gold model = Except to U.K.

Ref. No.	Part No.	Part Name	Remarks	Q'ty	Ref. No.	Part No.	Part Name	Remarks	Q'ty
1	1U-2817 E	Main unit Ass'y	Europe model	1	36	415 0299 000	Capacitor cover		1
1	1U-2817 F	Main unit Ass'y	U.K. model	1	37	254 6201 002	Electrolytic capacitor	C257,258	2
2	1U-2818	Tuner unit Ass'y		1	38	415 0234 007	Insulating sheet		4
3	KU-9328	Display unit Ass'y		1	39	271 0240 006	Transistor 2SA1491(O/P/Y)	TR323,324	2
3-1		Display & Volume unit			40	273 0389 002	Transistor 2SC3855(O/P/Y)	TR321,322	2
3-2		H/P J.& Remocon unit			41	206 1075 030	Fuse (2.0A)	F401	1
4	1U-2915	Power unit Ass'y		1	42	206 1075 001	Fuse (1A)	Except to U.K.	1
5	144 2487 002	Front panel	Black model	1	43	214 0167 005	Relay(G5Z-2A)	RL451,452	2
5	144 2487 015	Front panel	Gold model	1	44	214 0127 003	Relay(RY-12W)	RL453	1
6-1	146 1602 004	Inner panel Ass'y	Black model	1	45	105 1187 104	:Rear panel	Europe model	1
6-2	143 9187 001	(Window)			45	105 1187 117	:Rear panel	U.K model	1
6-1	146 1602 017	Inner panel Ass'y	Gold model	1	46	204 8485 009	4P pin jack(S-GND)		2
6-2	143 9187 001	(Window)			47	204 8486 008	6P pin jack(S-GND)		1
7	113 9325 008	Series button (A)	Black model	1	48	205 0484 001	8P speaker terminal	Europe model	1
7	113 9325 011	Series button (A)	Gold model	1	48	205 0472 013	8P speaker terminal	U.K model	1
8	113 9326 007	Series button (B)	Black model	1	49	203 2348 009	2P inlet	CN2A	1
8	113 9326 010	Series button (B)	Gold model	1	50	203 3961 004	1P AC outlet	Except to U.K.	1
9	113 9324 229	Function button	Black model	1	51	205 0847 004	3P antenna terminal(PAL/F)		1
9	113 9324 232	Function button	Gold model	1	53	009 0134 009	29P FFC cable		1
10	113 9323 000	Push button (SP)	Black model	2	54	445 0048 003	Cord holder(L=76)		1
10	113 9323 013	Push button (SP)	Gold model	2	56	417 0520 102	Sub radiator		1
11	113 1721 105	Power button Ass'y	Black model	1	<b>SCREWS</b>				
11	113 1721 011	Power button Ass'y	Gold model	1	100	477 0262 006	Special screw		1
12	112 0739 001	:*Knob (Maru)	Black model	4	101	473 8007 009	Cup screw 3x12		8
12	112 0739 014	:*Knob (Maru)	Gold model	4	102	473 7500 044	Screw 3x8 (P) BK		9
13	112 0737 029	:*Volume knob	Black model	1	103	473 7015 018	Screw 3x8 (S) BK		5
13	112 0737 032	:*Volume knob	Gold model	1	104	473 7002 018	Screw 3x8 (S)		12
14	204 8354 017	Head phone jack	Black model	1	105	477 8057 004	Fixing screw 3x10 BK		11
14	204 8355 003	Head phone jack	Gold model	1	106	473 7004 016	Screw 4x6 (S)		4
15	212 1140 009	Push switch(ESB6440)	SW3002,303	2	107	473 7007 013	Screw 4x10 (S) BK	Black model	4
16	211 9131 004	Variable resistor	VR307	1	107	473 4801 005	Screw 4x8	Gold model	4
17	211 0842 017	Variable resistor	VR303	1					
18	211 0843 016	Variable resistor	VR304	1					
19	211 0841 018	Variable resistor	VR301	1					
20	211 0831 002	Variable resistor	VR302	1					
23	102 0571 013	Top cover	Gold model	1					
23	102 0571 000	Top cover	Black model	1					
24	414 0740 006	Shield plate		1					
25	499 0150 008	Remote sensor	SBX1610-52	1					
26	393 4155 002	FL tube	FIP14AM7R	1					
27	212 1031 008	Power switch (TV-5)		1					
28	212 5604 910	Tact switch		16					
		SW601-603,605-617							
29	411 1323 300	Chassis		1					
30	104 0230 101	:Foot Ass'y		4					
31	449 0033 049	Locking card spacer		2					
33	216 0065 006	Front end		1					
34	417 0529 006	:Power radiator		1					
35	233 6194 002	Power Transformer		1					

**PACKING & ACCESSORIES**

Ref. No.	Part No.	Part Name	Remarks	Q'ty
1	505 0283 018	:Envelope		1
1	511 2840 001	Operating instructions		1
1	231 1914 003	AM loop antenna		1
1	395 0023 008	:FM antenna Ass'y		1
1	399 0242 001	Remoto control unit	RC-174	1
1	206 2108 003	:AC connectorWith plug	Europe model	1
1	206 2113 001	:AC cordWith connector	U.K model	1
1	505 0131 050	Cabinet cover		1
2	503 1140 109	:Cushion		2
1	501 1871 045	Carton case		1

### WIRING DIAGRAM

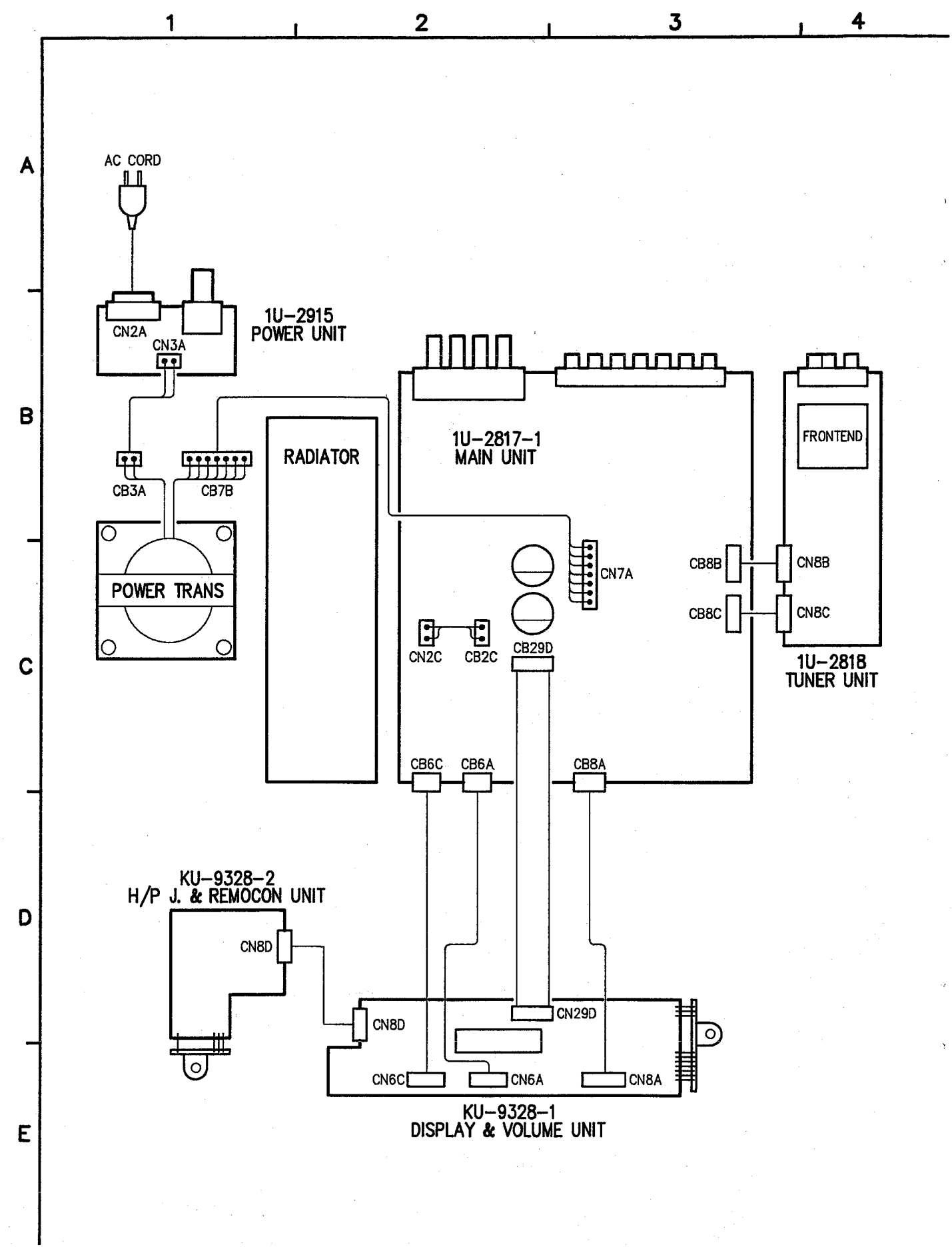



# SCHEMATIC DIAGRAM

1                      2                      3                      4                      5                      6

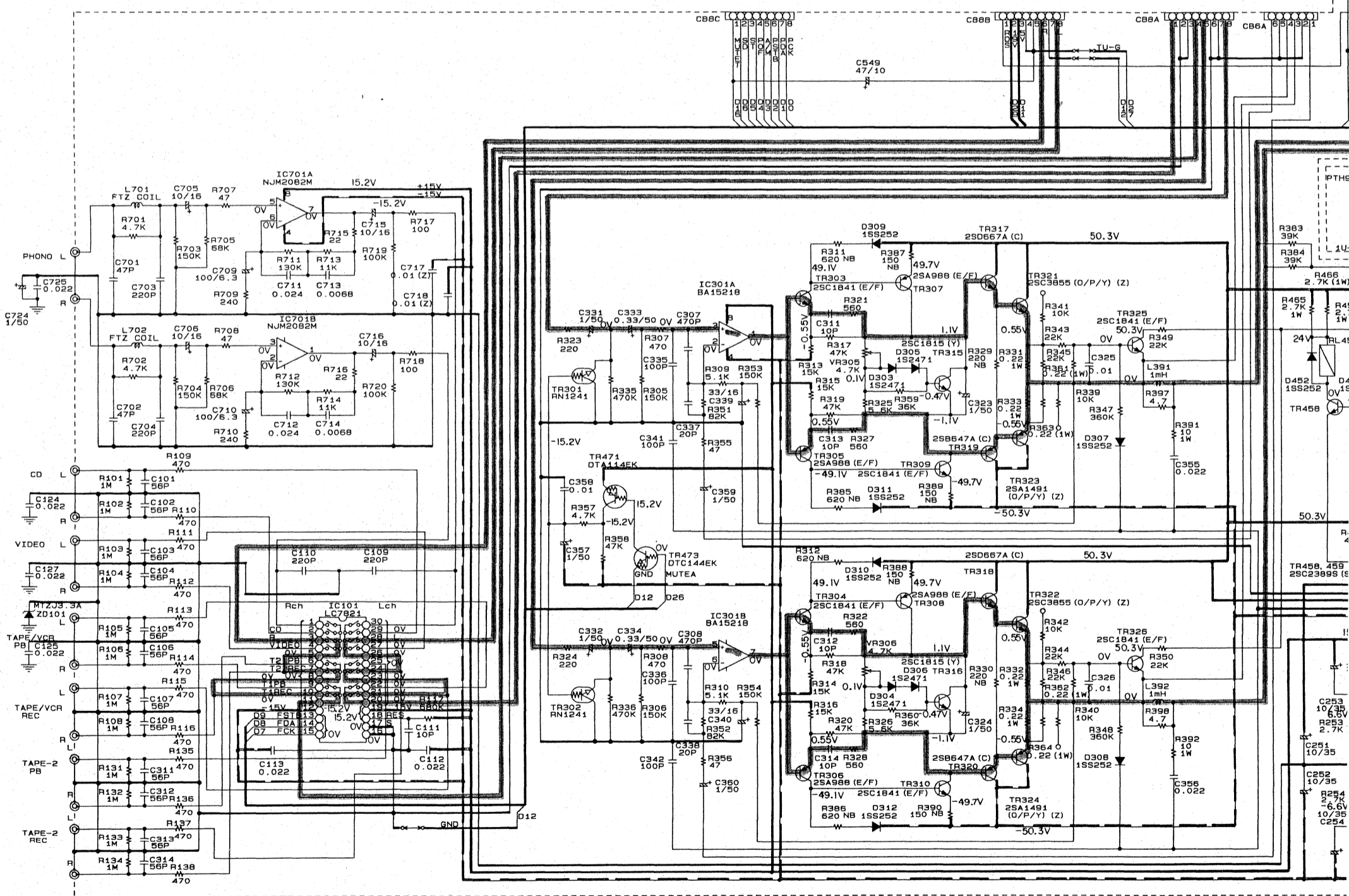
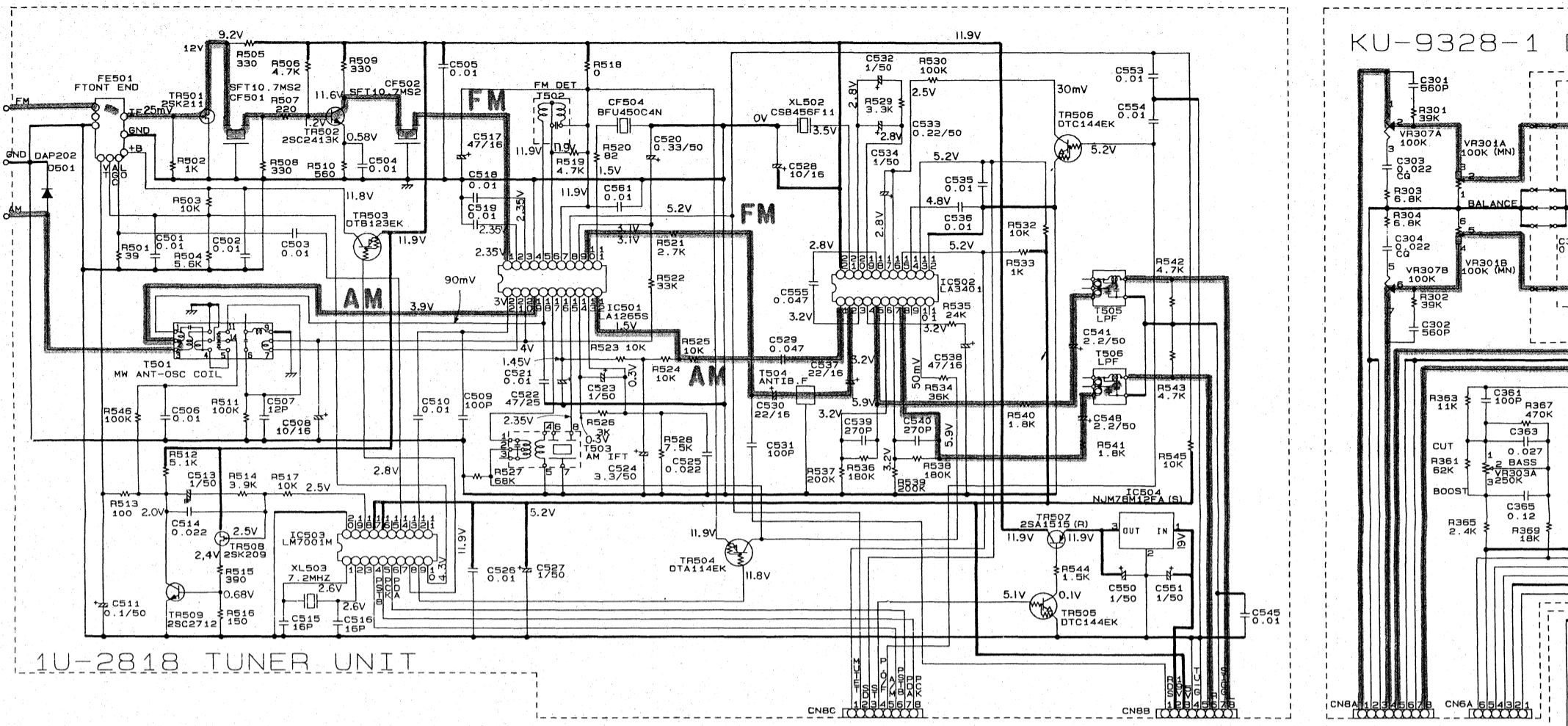

**WARNING:**  
Parts marked with this symbol  have critical characteristics. Use ONLY replacement parts recommended by the manufacturer.

**CAUTION:**  
Before returning the unit to the customer, make sure you have performed a current check or (2) a line to chassis resistance check. If the current exceeds 0.5 milliamperes, or if the resistance from chassis to cord is less than 240 kohms, the unit is defective.

**WARNING:**  
DO NOT return the unit to the customer until the problem has been corrected.

**NOTES:**  
Circuit and parts are subject to change without notice.





# SEMICONDUCTORS

## IC's

TMP87CM71F-6348 (IC601)

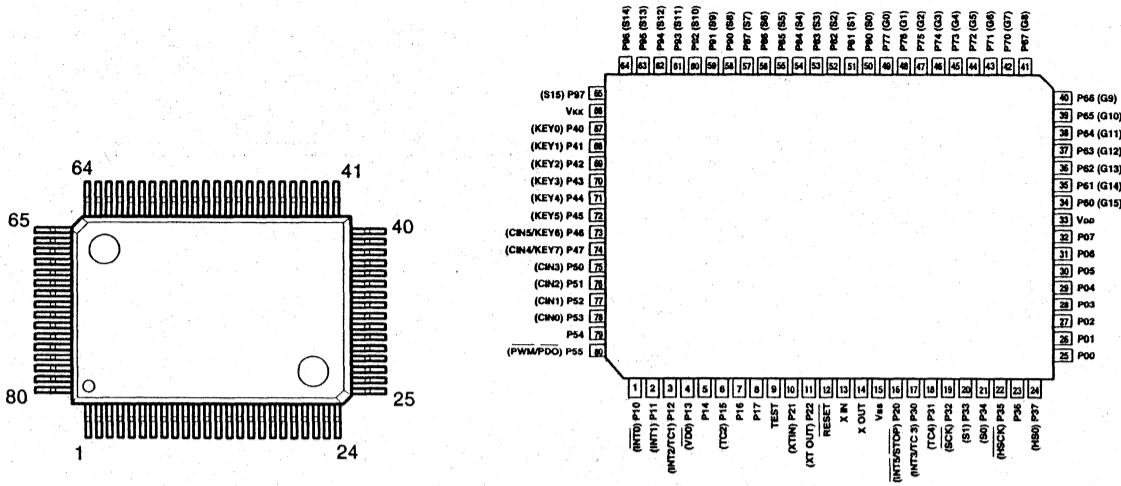

TMP87CM71F Port Allocation Table

Pin No.	Symbol	I/O	Logic	Initial Setting	Function
1	STOP	I	L	—	Power down detection ("L" = at power down).
2	MUTE (A)	I	—	—	MUTE (A) output ("H" = MUTE).
3	RDS	I	Serial	—	RDS data (start) input.
4	RES	O	L	H	LC7074 reset output.
5	GND	I	Serial	—	Not used.
6	FCK	O	Serial	L	Function control output (LC7821) for F-CK.
7	FDA	O	Serial	L	Function control output (LC7821) for F-DATA.
8	F-STB	O	H	L	Function control output (LC7821) for F-STB.
9	GND	I	—	—	Connect to GND.
10	SD	I	L	—	Tuned signal input ("L" = at tuned in).
11	GND	I	—	—	Not used.
12	RESET	I	L	—	Reset input.
13	XIN	I	—	—	Oscillation circuit (4MHz).
14	XOUT	I	—	—	Oscillation circuit (4MHz).
15	Vss	PW	—	—	GND
16	GND	I	—	—	GND
17	REM	I	L	—	Remote control signal input.
18	ST	I	L	—	Stereo signal input ("L" = at stereo).
19	RCK	I	Serial	—	RDS data (clock) input.
20	RDA	I	Serial	—	RDS data (data) input.
21	GND	I	—	—	Not used.
22	PCK	O	Serial	L	LM7001 control output for PLL-CK (CL).
23	PDA	O	Serial	L	LM7001 control output for PLL-DATA (DATA).
24	PSTB	O	H	L	LM7001 control output for PLL-STB (CE).
25	GND	O	—	L	GND
26	GND	O	—	L	GND
27	AM	O	L	L	AUTO/MANUAL control.
28	GND	I	—	—	Not used.
29	P.O/F	O	H	L	Power control output ("H" = ON).
30	VR-UP	O	H	L	Power volume control output (LB1639 ON = at "H").
31	VR-D	O	H	L	Power volume control output (LB1639 ON = at "H").
32	SP-R	O	H	L	Speaker relay control output (ON = at "H").
33	VDD	PW	—	—	+5V
34	GND	I	—	—	GND
35	GND	I	—	—	GND
36	1G	O	—	—	FL tube control output for 1G.
37	2G	O	—	—	FL tube control output for 2G.
38	3G	O	—	—	FL tube control output for 3G.
39	4G	O	—	—	FL tube control output for 4G.
40	5G	O	—	—	FL tube control output for 5G.
41	6G	O	—	—	FL Tube control output for 6G.
42	7G	O	—	—	FL Tube control output for 7G.
43	8G	O	—	—	FL Tube control output for 8G.
44	9G	O	—	—	FL Tube control output for 9G.
45	10G	O	—	—	FL Tube control output for 10G.
46	11G	O	—	—	FL Tube control output for 11G.
47	12G	O	—	—	FL Tube control output for 12G.
48	13G	O	—	—	FL Tube control output for 13G.
49	14G	O	—	—	FL Tube control output for 14G.
50	S0 (a)	O	—	—	FL Tube control output for P(a).
51	S1 (b)	O	—	—	FL Tube control output for P(b).
52	S2 (c)	O	—	—	FL Tube control output for P(c).
53	S3 (d)	O	—	—	FL Tube control output for P(d).
54	S4 (e)	O	—	—	FL Tube control output for P(e).
55	S5 (f)	O	—	—	FL Tube control output for P(f).
56	S6 (g)	O	—	—	FL Tube control output for P(g).
57	S7 (h)	O	—	—	FL Tube control output for P(h).
58	S8 (i)	O	—	—	FL Tube control output for P(i).
59	S9 (k)	O	—	—	FL Tube control output for P(k).
60	S10 (m)	O	—	—	FL Tube control output for P(m).
61	S11 (n)	O	—	—	FL Tube control output for P(n).
62	S12 (p)	O	—	—	FL Tube control output for P(p).
63	S13 (q)	O	—	—	FL Tube control output for P(q).
64	S14 (r)	O	—	—	FL Tube control output for P(r).
65	S15 (s)	O	—	—	FL Tube control output for P(s).
66	Vkk	PW	—	—	-15V
67	GND	I	—	—	GND
70	GND	I	—	—	GND
71	VA	O	L	H	Video In/Out control ("L" = at selection) BV4066.
72	VB	O	L	H	Video In/Out control ("L" = at selection) BV4066.
73	K1	I	—	—	Key input (A/D conversion input).
74	K2	I	—	—	Key input (A/D conversion input).
75	K3	I	—	—	Key input (A/D conversion input).
76	K4	I	—	—	Key input (A/D conversion input).
77	VER	I	—	—	Forwarding country setting.
78	VER	I	—	—	Specification setting.
79	MUTE (T)	O	H	H	MUTE output ("H" = MUTE).
80	GND	I	—	—	GND

LM7001 (IC503)

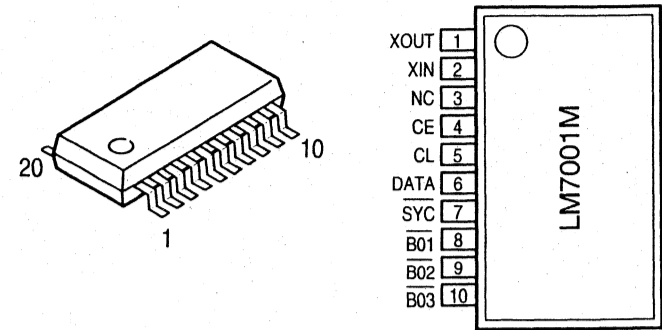

LA3401 (IC502)

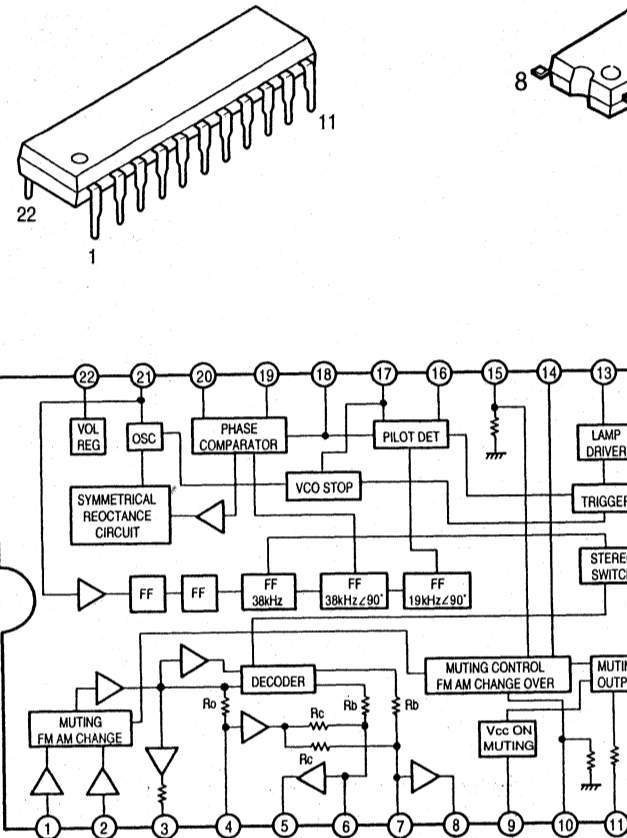

BA6208F

## TRANSISTORS

2SA988(E/F)  
2SA1515(R)  
2SC1815(Y)  
2SC1841(E/F)

2SB647A(C)  
2SB1041(R)  
2SD667A(C)

2SA933S(S)  
2SA1038S(S/E)  
2SC1740S(E)  
2SC2389S(S/E)

2SB1328(P)  
2SD2004(P)

Digital Transistor  
(Built in Resistors)

DTA · DTBEK Series

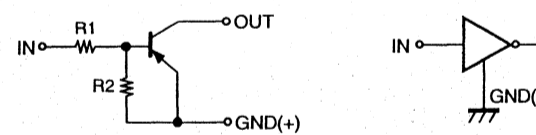

	R1	R2
DTA114EK	10kohm	10kohm
DTB123EK	2.2kohm	2.2kohm

DTCEK Series

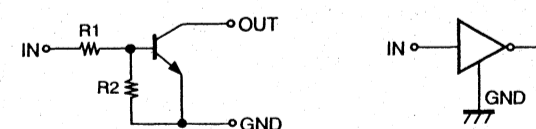

	R1	R2
DTC114EK	10kohm	10kohm
DTC143EK	4.7kohm	4.7kohm
DTC144EK	47kohm	47kohm

2SA1491 (O/P/Y) (TR323,324)  
2SC3855 (O/P/Y) (TR321,322)

2SB1186A (D)  
2SD1763A (D)

RN-1241(A/B)

RN-1241

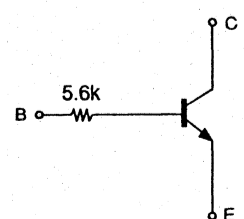
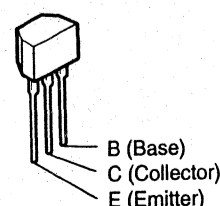
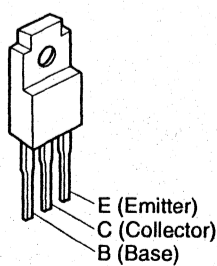
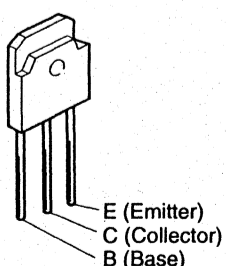

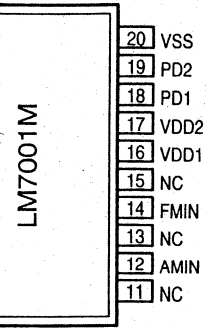

**LA1265 (S)**  
(IC501)

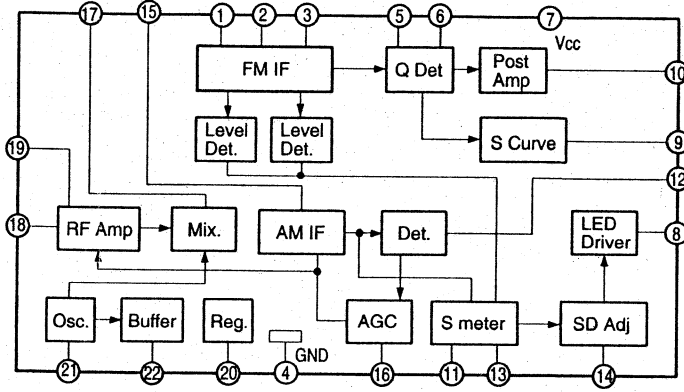
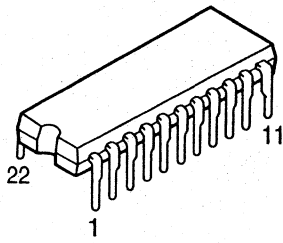

**NJM78M12FA (IC504)**  
**BA178M06 (IC401)**

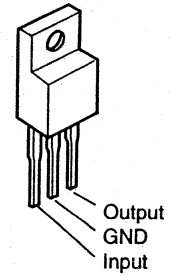

**LC7821 (IC101)**

**BA6208F (IC602)**

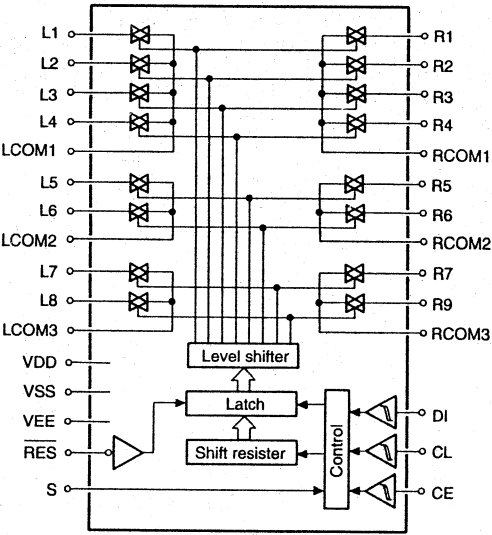
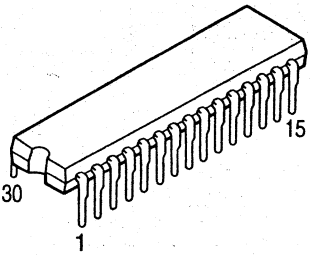
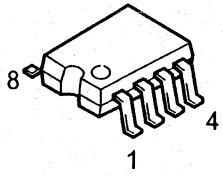

**NJM2082MD (IC701)**

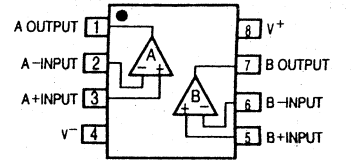
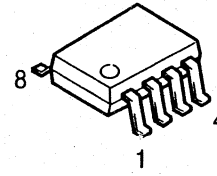

**BA15218F (IC301)**

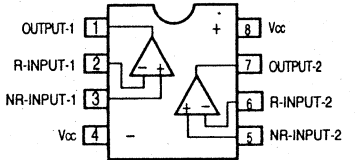
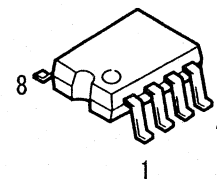

**SAA6579T (IC801)**

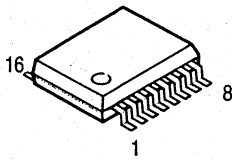

Pin No.	Symbol	Description
1	QUAL	Quality indication output.
2	RDDA	RDS data output.
3	V <sub>ref</sub>	Reference voltage output (0.5 V <sub>DDA</sub> ).
4	MUX	Multiplex signal input.
5	V <sub>DDA</sub>	+5 V supply voltage for analog part.
6	V <sub>SSA</sub>	Ground for analog part (0 V).
7	CIN	Subcarrier input to comparator.
8	SCOUT	Subcarrier output of reconstruction filter.
9	TSTLD	Test control.
10	TEST	Test enable.
11	V <sub>SSD</sub>	Ground for digital part (0 V).
12	V <sub>DDD</sub>	+5 V supply voltage for digital part.
13	OSCI	Oscillator input.
14	OSCO	Oscillator output.
15	T57	57 kHz clock signal output.
16	RDCL	RDS clock output.

**LC7074M (IC802)**

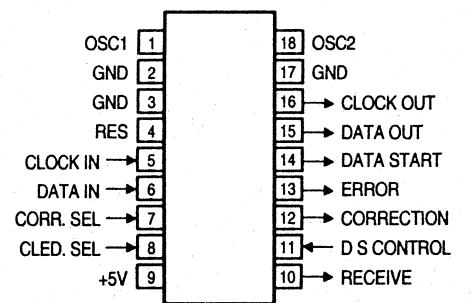
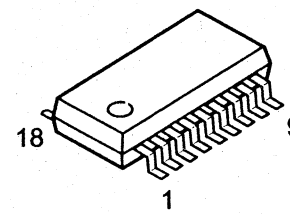

**Series**

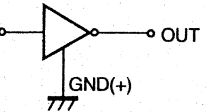

R2
10kohm
2.2kohm

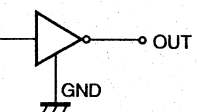

R2
10kohm
4.7kohm
47kohm

**2SK209 (Y/GR)**

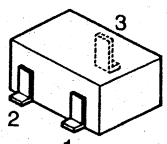

1: Drain  
2: Source  
3: Gate

**2SA1037 (S/R)**  
**2SC2412 (S)**  
**2SC2413K (Q)**  
**2SC2712 (Y/GR)**  
**DTB123EK**

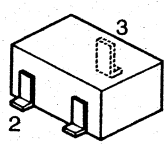

1: Emitter  
2: Base  
3: Collector

**DIODES (included LED)**

**1SS252**

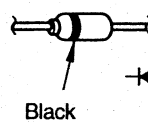

**1S2471**

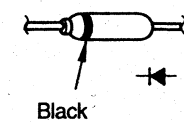

**MTZJ3.3A**  
**MTZJ6.2A**  
**MTZJ6.8C**

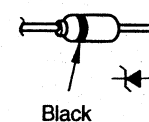

**MTZJ7.5C**  
**MTZJ27D**

**4D4B42**

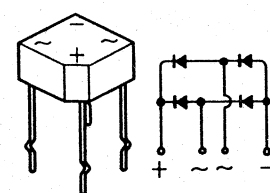

**SF0R1A42**

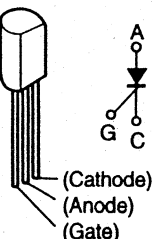

**2SK211 (Y/RG)**

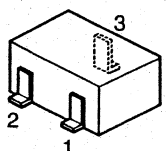

1: Gate  
2: Drain  
3: Source

**1SR35-200 (A)**

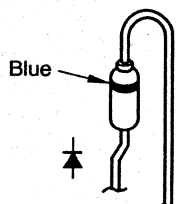

**DAP202K (Chip)**

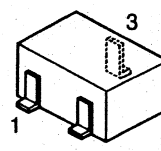

**DAP202K**

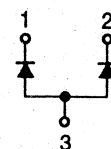

1: Cathode  
2: Cathode  
3: Anode

**DTZ8.2B**

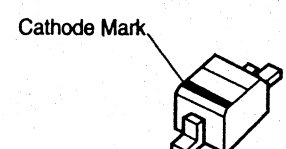

**SBX1610-52 (Remote Control Sensor)**

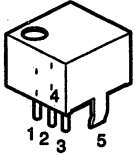

- 1. Vcc
- 2. Output
- 3. GND
- 4. Case Fin
- 5. Case Fin

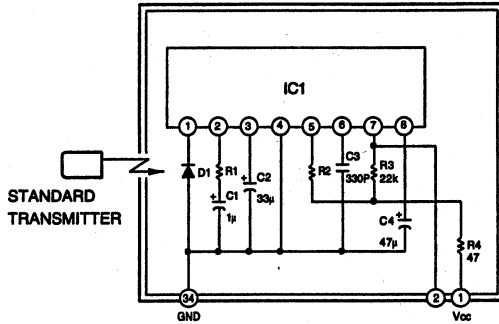

- IC1 : CX20106A Chip
- D1 : PIN Photodiode Chip
- C1, C2, C4 : Aluminum Electrolytic Capacitor
- C3 : SL Characteristic ±5%
- R1 : Gain control resistor
- R2 : fo control resistor (Using ±1%)
- R (Other than above items) : ±5%