

DENON

Hi-Fi Component Tuner Amplifier

SERVICE MANUAL MODEL DRA-750

For European Model

SOLID STATE
TUNER AMPLIFIER



CONTENTS

PRECAUTION FOR INSTALLATION	2
ADVICE FOR USE	2
SPECIFICATIONS	2
NAME AND FUNCTION OF PARTS	3
CONNECTIONS	4
BLOCK DIAGRAM	6
METHOD OF ADJUSTMENTS	7
SEMICONDUCTORS	10
PRINCIPLE OF SUPER SEARCHER SYSTEM (SSS)	12
PRINTED WIRING BOARD PATTERNS AND PARTS LIST	
ETC0658J TRAP UNIT	12
ETC0729H TUNER UNIT	13
ETC0730Q CONTROL UNIT	14
ETC9028 POWER PRE UNIT	15
WIRING DIAGRAM	16
SCHEMATIC DIAGRAM	17
EXPLODED VIEW OF CHASSIS AND CABINET	18

NIPPON COLUMBIA CO., LTD.

PRECAUTIONS FOR INSTALLATION

DRA-750 uses a newly developed heat emitting unit by employing heat pipes. Since the heat pipes contain a coolant, the DRA-750 must be set level or the desired heat emitting effect cannot be achieved. Always install this unit horizontally.

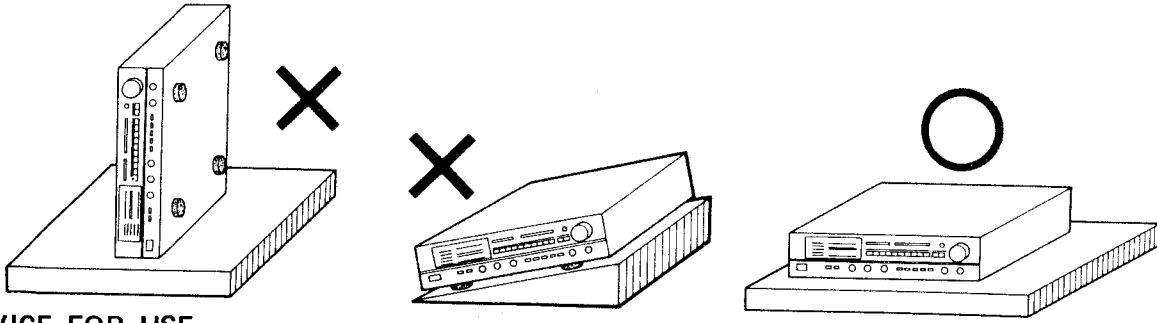

ADVICE FOR USE

- Do not place the set in direct sunlight, in hot areas such as near heating equipment, with high humidity or dust levels. This may cause damage to the unit.
- Check that all parts are connected correctly before turning on the power source.
- When user is absent for long periods, be sure to remove plug from wall socket.
- Do not use insecticide, benzene or thinner near the unit, or the cabinet color will fade. Avoid using polish: use a soft cloth (e.g. silicon cloth).
- Although the unit is designed to support weight, it is recommended that the user does not place anything too heavy on it. Consider air circulation before placing anything on the unit. If you place any equipment likely to induce hum, make sure there is enough space to between each piece of equipment prevent such hum.

SPECIFICATIONS

AMPLIFIER SECTION

Continuous Power Output: 70 W + 70 W at 8 ohm,
85 W / 8 ohm DIN

Power Bandwidth (IHF): 5 Hz ~ 40 kHz (THD 0.05% both ch.
driven at 8 ohm)

**Total Harmonic Distortion
(20 Hz to 20 kHz):** -3 dB power into 8 ohms 0.008%

**Intermodulation Distortion
(60 Hz : 7 kHz,
4 : 1 SMPTE):** rated power into 8 ohms 0.005%

Damping Factor: More than 80 (at 1 kHz, 8 ohms)

PREAMPLIFIER SECTION

Frequency Response: PHONO RIAA Standard Curve
(Recording Output)
(MM) 20 Hz ~ 20 kHz ±0.3 dB
(MC) 50 Hz ~ 20 kHz ±0.5 dB
TAPE, VIDEO/AUX, DAD/AUX
20 Hz ~ 50 kHz ±1.5 dB

**Input Sensitivity and
Impedance:** PHONO MM 2.5 mV 47 k ohm
MC 0.25 mV 100 ohm
TAPE, VIDEO/AUX, DAD/AUX
150 mV 33 k ohm

**Maximum Input Level
(at 1 kHz):** PHONO MM 200 mV
MC 20 mV

**Signal to Noise Ratio
(IHF-A):** PHONO MM @ 5.0 mV input
90 dB
MC @ 0.5 mV input
74 dB
TAPE, VIDEO/AUX, DAD/AUX
@ 150 mV input 95 dB

Tone Control Range: BASS at 100 Hz ±8 dB
TREBLE at 10 kHz ±8 dB

Loudness Control Effect: VARIABLE LOUDNESS "10"
POSITION +10 dB / +5 dB

Subsonic Filter Effect: 15 Hz / -6 dB oct.

TUNER SECTION

[FM]

Receiving Range: 87.5 ~ 108 MHz

Usable Sensitivity: 0.9 μV (10.3 dBf)

50 dB Quieting Sensitivity: MONO 2.0 μV (17.2 dBf)
STEREO 23 μV (38.5 dBf)

Signal to Noise Ratio: MONO 83 dB
STEREO 81 dB

**Total Harmonic Distortion
1 kHz:** MONO 0.1%
STEREO 0.3%

Selectivity: 70 dB (±400 kHz)

Capture Ratio: 1.5 dB

Image Rejection: 75 dB

AM Suppression: 60 dB

Frequency Response: 30 Hz ~ 15 kHz ^{+0.2}_{-1.5} dB

Stereo Separation: 50 dB (1 kHz)

IF Rejection: 85 dB

[AM]

Receiving Range: 522 ~ 1611 kHz

Usable Sensitivity: 18 μV

Signal to Noise Ratio: 55 dB

GENERAL

Power Supply: AC 220 V, 50 Hz

Power Consumption: 150 W

Dimensions: 434 mm (W) x 112 mm (H)
x 400 mm (D)
(17-3/32" x 4-13/32" x 15-3/4")

Weight: 9.0 kg (19 lbs 14 oz)

Design and specifications are subject to change without prior notice.

NOTE: This Service Manual is prepared base on Gold Version.

NAME AND FUNCTION OF PARTS
FRONT PANEL

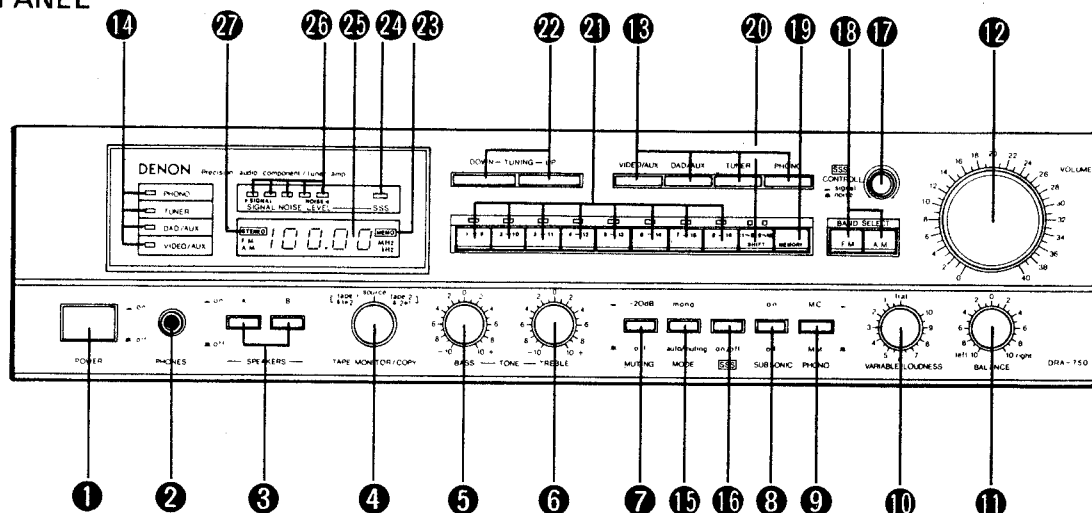

Fig. 1

- | | |
|---|--|
| <ul style="list-style-type: none"> ① POWER (Power Switch) ② PHONES (Head Phone Jack) ③ SPEAKERS (Speaker Select Switch) ④ TAPE MONITOR/COPY ⑤ BASS (Bass Control) ⑥ TREBLE (Treble Control) ⑦ MUTING (Muting Switch) ⑧ SUBSONIC FILTER (Subsonic Filter Switch) ⑨ PHONO (Cartridge Select Switch) <input type="checkbox"/> : MC <input type="checkbox"/> : MM ⑩ VARIABLE LOUDNESS ⑪ BALANCE (Balance Control) ⑫ VOLUME (Volume Control) ⑬ FUNCTION (Input Select Switch) • PHONO, • TUNER, • DAD/AUX, • VIDEO/AUX ⑭ FUNCTION INDICATOR ⑮ MODE (FM Mode, Muting and Tuning Mode Switch) <input type="checkbox"/> : auto/muting, <input type="checkbox"/> : mono | <ul style="list-style-type: none"> ⑯ SSS ON/OFF (See Page 12 for Details Regarding the SSS) ⑰ SSS CONTROLLER (SSS Control Knob) ⑱ BAND SELECT (Band Selector Buttons) • AM, • FM ⑲ MEMORY (Memory Button) ⑳ SHIFT (Shift Button) ㉑ PRESET CHANNEL 1 ~ 16 (Station Presetting Buttons) ㉒ TUNING (Tuning Buttons) UP, DOWN ㉓ MEMORY INDICATOR ㉔ SSS (SSS Indicator) ㉕ DIGITAL FREQUENCY INDICATOR ㉖ SIGNAL/NOISE LEVEL (Signal/Noise Level Indicator) ㉗ STEREO (Stereo Indicator) |
|---|--|

BACK PANEL

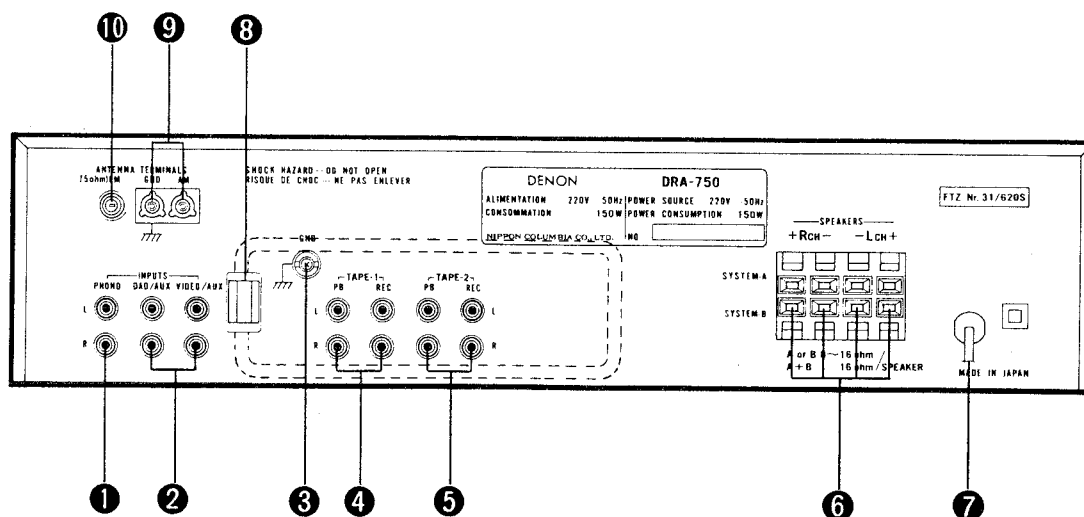

Fig. 2

- | | |
|--|--|
| <ul style="list-style-type: none"> ① PHONO (Phono Input Terminals) ② DAD/AUX, VIDEO/AUX (Input Terminals) ③ GND (Grounding Terminal) ④ ⑤ TAPE-1, -2 (Playback and Recording Terminals) ⑥ SPEAKERS (Speaker Terminals) | <ul style="list-style-type: none"> ⑦ AC Cord (Power Cord) ⑧ AM LOOP ANT (AM Loop Antenna) ⑨ AM ANT (AM Antenna Terminal) ⑩ FM ANT 75 ohm (FM Antenna Terminal) |
|--|--|

CONNECTIONS

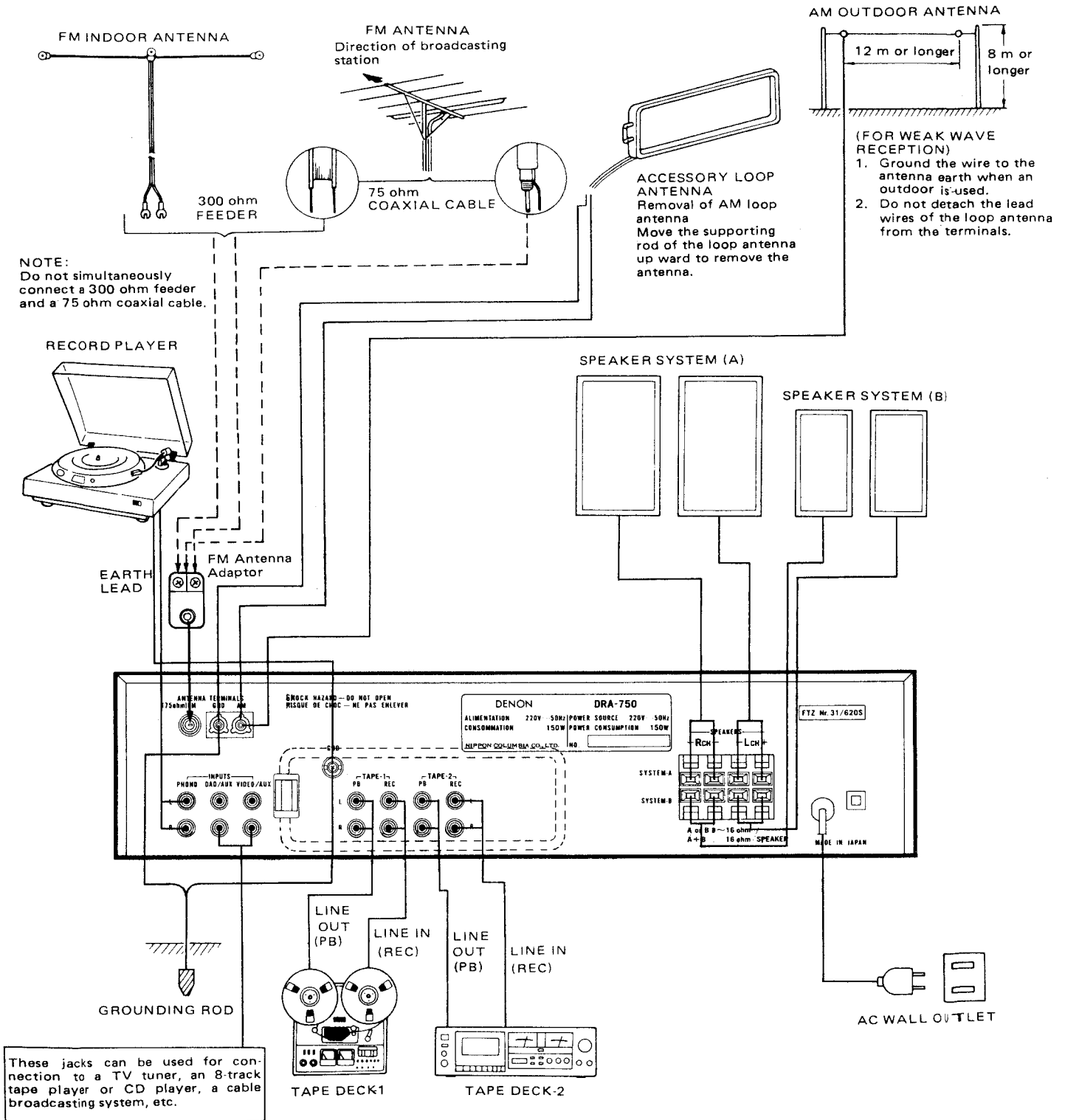

Fig. 3

- Do not plug the power source cord into an AC outlet until all the connections are completed.
- Connect the right (R) channel plug to the right (R) channel jack, and the left channel plug to the left channel jack.
- Insert the plugs firmly into the corresponding jacks. If a connection is incomplete, noise may be generated.
- Plug the power source cord for audio equipment into the AC OUTLET terminal. Do not use this terminal for other electric appliances such as hair dryer. (NOT INCLUDED IN SYSTEM FOR EUROPEAN USE)
- Do not bundle the pin plug cords with the power source cord and do not place the pin plug cords near the power transformer, or humming and other noise may be generated.
- Always connect the pin plug cord to the input terminal "PHONO" because this terminal is highly sensitive. If this terminal is not connected, induction hum may be generated.

ANTENNA INSTALLATION

● T TYPE FM INDOOR ANTENNA

The T type indoor antenna (300 ohm) can be used inside wooden houses when FM stations are local and strong signals can be received. While receiving an FM program, extend the horizontal part of the antenna. Orient the T-shaped part for optimal reception and mount the antenna on the wall or ceiling.

* In general, FM indoor antennas might not consistently assure stable reception, due to environmental changes. Use an FM indoor antenna temporarily until an outdoor antenna is installed.

● FM OUTDOOR ANTENNA CONNECTION (Fig. 4)

75 ohm coaxial cable (3C-2V, 5C-2V) is preferable to obtain better performance of the tuner.

* Contact your local dealer for details on selection and installation of the FM outdoor antenna.

* When a 300 ohm FM antenna is connected by a 75 ohm coaxial cable, a matching transformer is required.

● AM ANTENNA CONNECTION (Fig. 5)

Since the model is provided with a high performance AM loop antenna on the back panel, this accessory antenna can effectively be used for optimal reception in places where broadcasting stations are located nearby and relatively strong signals are received with low noise.

Orient the loop antenna horizontally to obtain optimal reception.

In places where strong, clear signals are not received due to particular location and/or environmental conditions, connect an insulated wire to the AM antenna terminals and attach it to the wall. In places where broadcasting stations are located too far away and only weak signals are received, or where signals are blocked by obstacles, install an AM outdoor antenna.

* Even if an AM outdoor antenna is installed, do not detach the AM loop antenna.

GROUNDING

If there is much noise during reception, it is recommended that a grounding wire be used.

Connect a thick insulated wire to the "GND" terminal, and wind the unconnected bare end around a metal water pipe, a grounding rod, or a grounded copper plate.

* Never connect grounding the wire to a gas pipe. This could cause fire or explosion.

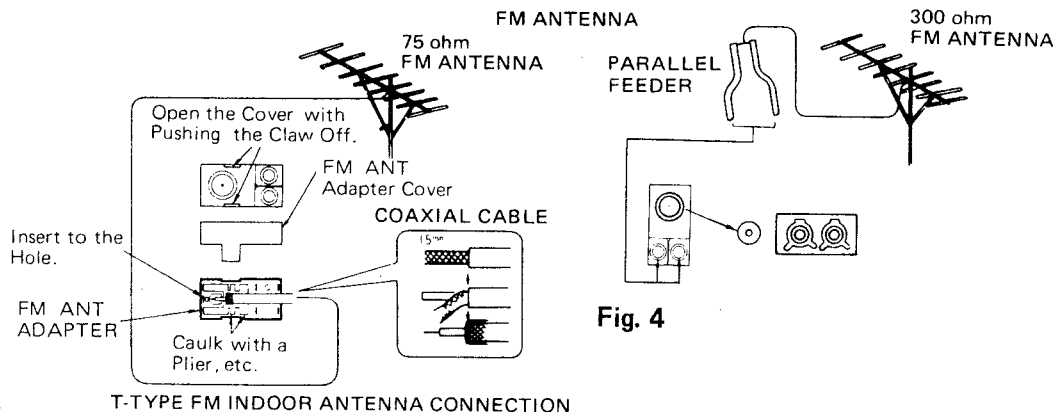

Fig. 4

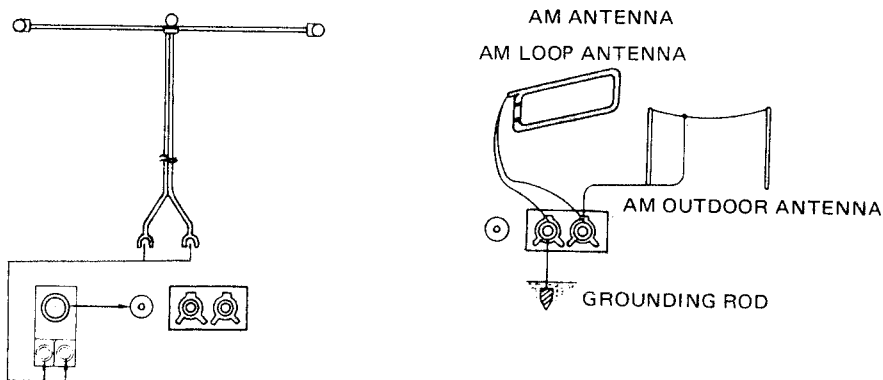

Fig. 5

Note: Two FM antennas should not be connected simultaneously. Even if an external AM antenna is used, the LOOP antenna connects with an AM loop antenna terminals on the back panel. Be sure the lead terminal does not touch the metal part of back panel.

BLOCK DIAGRAM

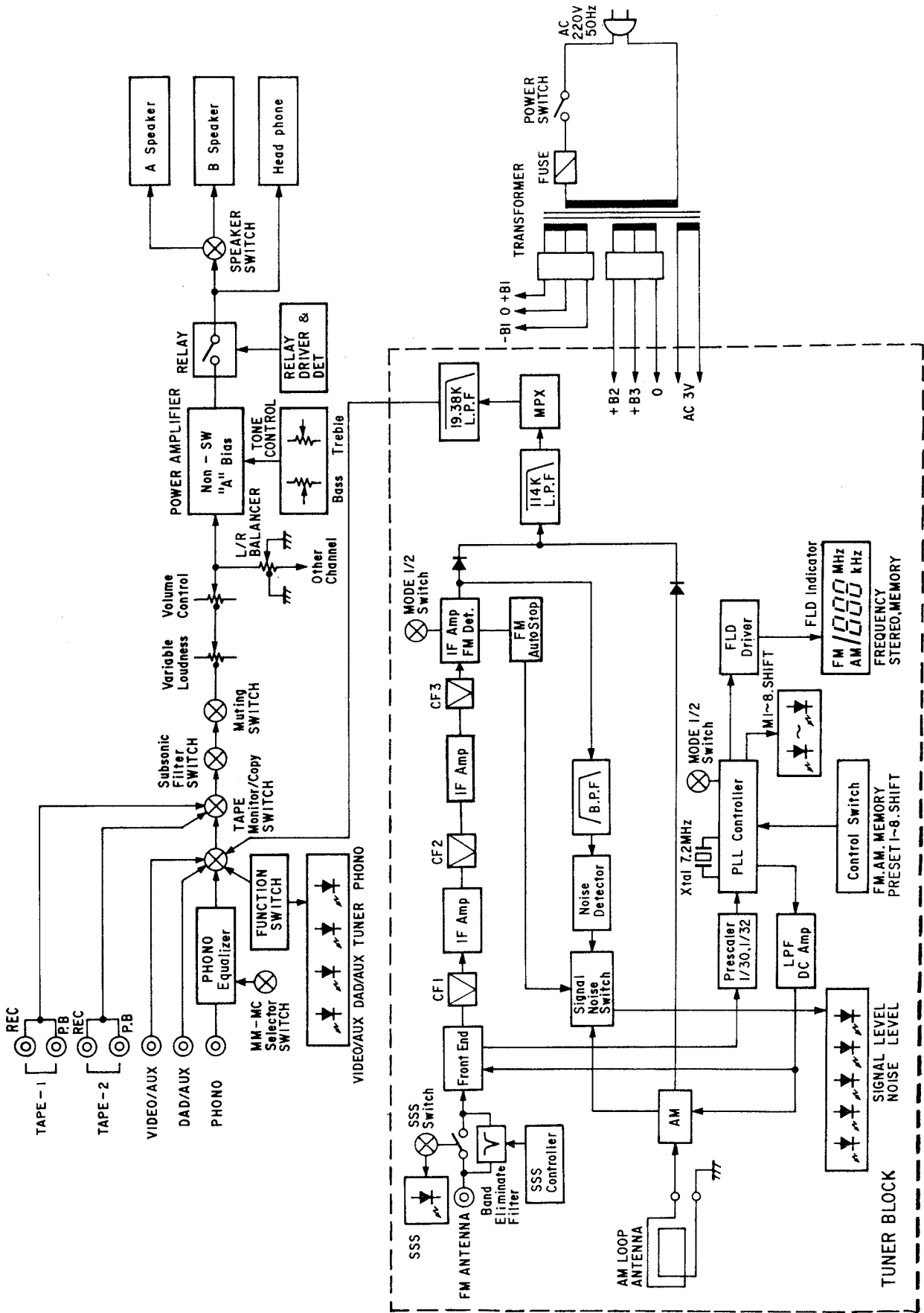

Fig. 6

METHOD OF ADJUSTMENTS

When making adjustments, be sure the power supply is at the rated voltage and the room air is in normal condition with respect to temperature and humidity.

• AMPLIFIER SECTION

1. IDLING CURRENT (Fig. 7)

(1) Set controls as follows.

POWER Switch → off (⏻)

VOLUME Control → 0 (min.)

SPEAKERS → off (⏻)

Temperature → 15°C ~ 30°C

VR3 and VR4 of the ETC9028-1 (POWER PRE Unit) → Center

Power supply → AC 220 V, 50 Hz.

(2) Connect Digital Voltmeter to the test points 38 (+), 39 (-) and 35 (+), 36 (-) of the ETC9028-1.

(3) Turn the Power Switch on and rotate VR3 clockwise so that the Digital Voltmeter reads 1mV ± 0.2 mV DC at the test point 38,39. Follow the same procedure to VR4 for test point 35,36.

(4) Warm up one minute, then readjust VR3 and VR4 as in step (3) so that the Digital Voltmeter reads 1.5 mV ± 0.3 mV DC.

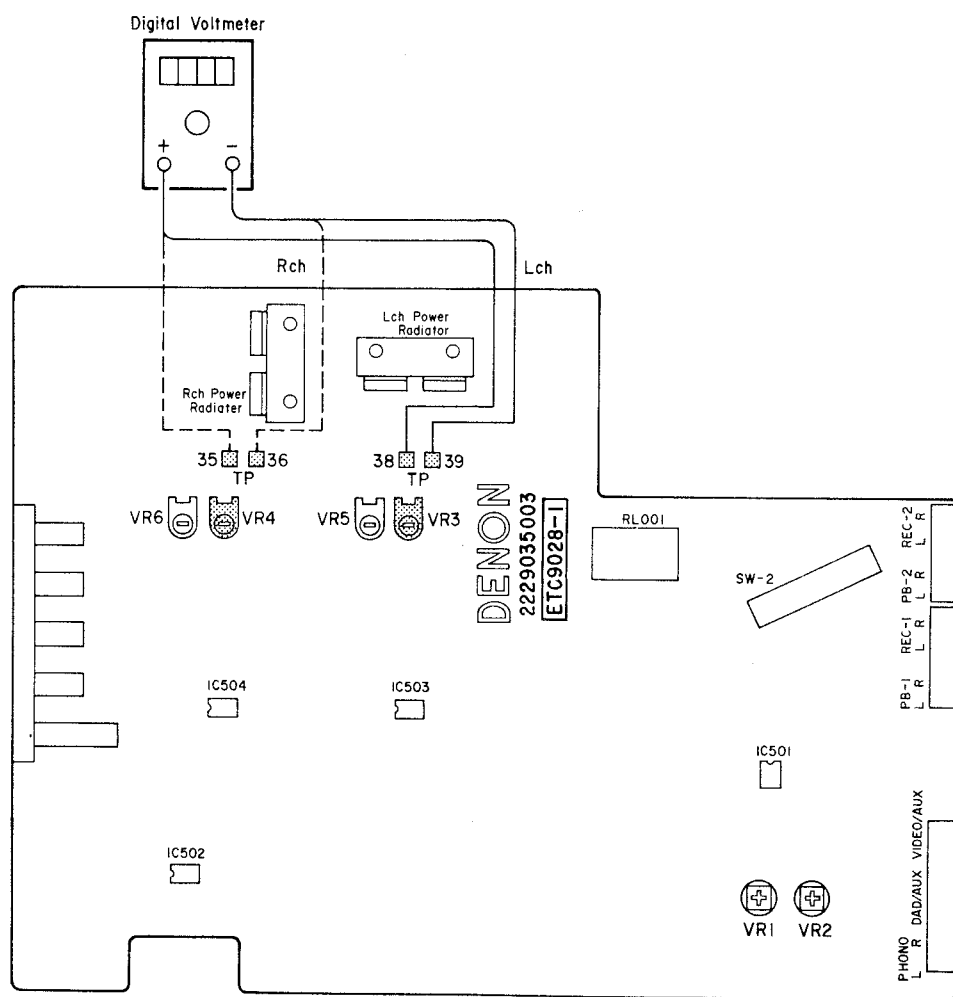

Fig. 7

• POWER AMP SECTION

2. DISTORTION (Fig. 8)

- (1) Connect 8 ohm resistors across the Speaker Terminals.
- (2) Turn the Power Switch on.
- (3) Set the Volume Control to "16".
- (4) Apply 20 kHz sine wave to DAD/AUX input terminal and adjust output level of the Oscillator so that 17Vrms are delivered across the 8 ohm resistor. (Apply both L and R-ch)
- (5) Adjust VR5 (L-ch) and VR6 (R-ch) for minimum distortion.

• EQ. AMP SECTION

3. NEUTRAL POINT (Fig. 8)

- (1) Set controls as follows.

TAPE MONITOR Switch	— source
INPUT SELECTOR Switch	— PHONO (PHONO INPUT Short)
VOLUME Control	— 0 (min.)
- (2) Connect Digital Voltmeter to REC-1 and REC-2 output Terminal.
- (3) Turn the Power Switch on.
- (4) Warm up 5 to 10 minutes, then adjust VR1 so that the DC Voltmeter reads $0 \pm 1mV$ at REC-1. Follow the same procedure to VR2 for REC-2.

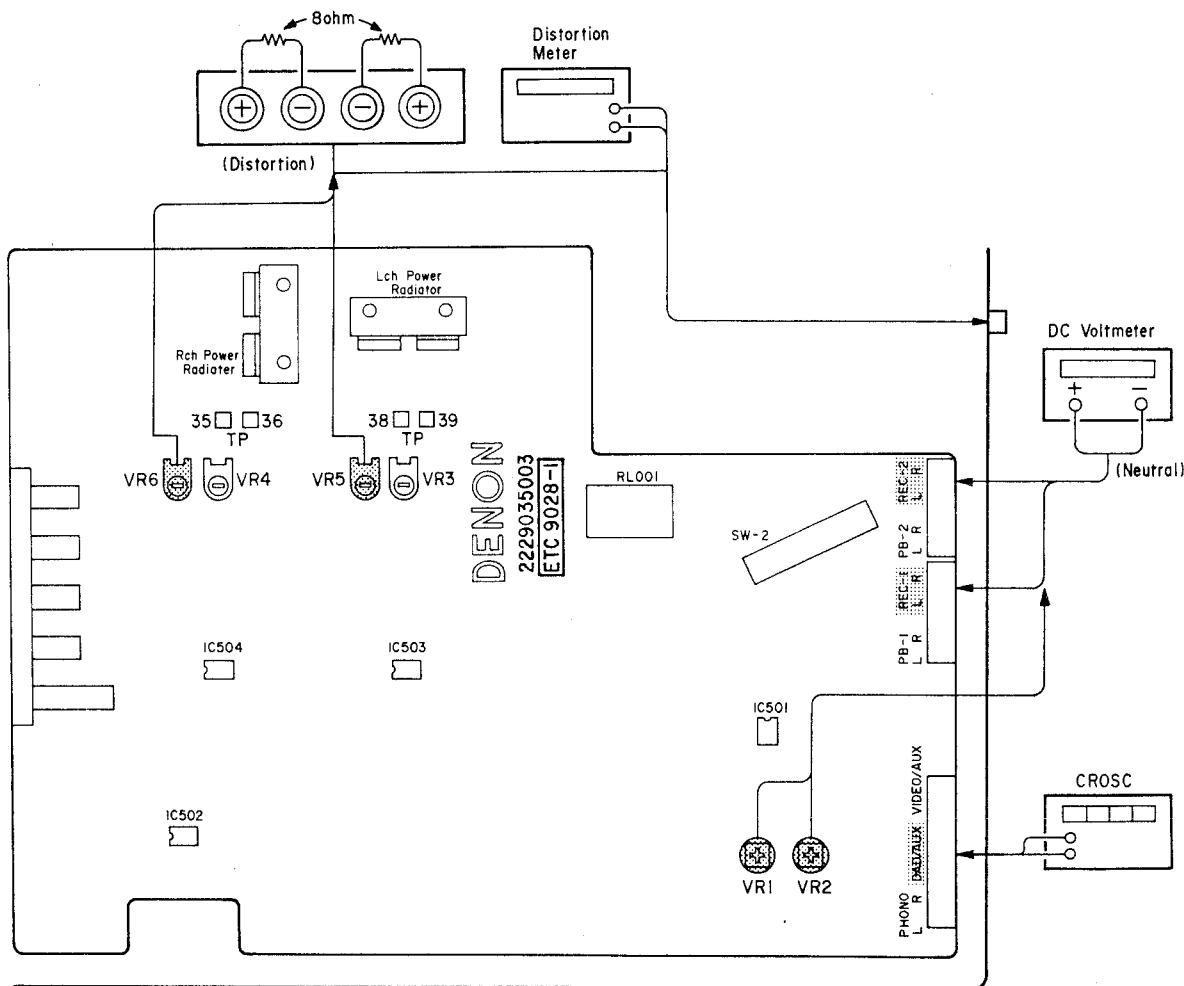

Fig. 8

• Tuner Section

ADJUSTMENT OF RF TRAP UNIT (ETC0658J) (SSS) on, MODE mono Table 1

Adjustment Item	Input Side			Output Side			Adjustment Point	Adjustment Value
	Measuring Instrument	Frequency	Input Level	Modulation	Connection Point	Measuring Instrument		
1 88 MHz Tracking Check	FM SSG	88.0 MHz	Variable depending on output waveform attenuation	Mono 1 kHz, 100%	Antenna Terminal	Digital Voltmeter	VC, G	3 V ± 10 mV at the time of adjustment to the max. point of output waveform attenuation using the SSS controller
2 108 MHz Tracking Check	FM SSG	108.0 MHz	Variable depending on output waveform attenuation	Mono 1 kHz, 100%	Antenna Terminal	Digital Voltmeter	VC, G	20 V ± 100 mV at the time of adjustment to the max. point of output waveform attenuation using the SSS controller
3 If NG in items 1 and 2, advance to items 4 to 6								
4 108 MHz Tracking	FM SSG	108.0 MHz	Variable depending on output waveform attenuation	Mono 1 kHz, 100%	Antenna Terminal	Oscilloscope	Output (L)	Output waveform attenuation is max. at 20 V ± 50 mV
5 88 MHz Tracking	FM SSG	88.0 MHz	Variable depending on output waveform attenuation	Mono 1 kHz, 100%	Antenna Terminal	Oscilloscope	Output (L)	Output waveform attenuation is max. at 3 V ± 5 mV
6 Repeat the adjustment in items 4 and 5 so that the waveform attenuation is maximum at the rated voltage								
7 Adjustment of Attenuation	FM SSG	98.0 MHz	Variable depending on output waveform attenuation	Mono 1 kHz, 100%	Antenna Terminal	Oscilloscope	Output (L)	Adjust to max. attenuation after adjustment to the max. point of output waveform attenuation using the SSS controller

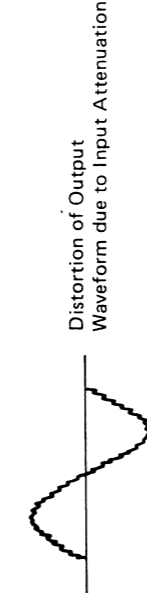
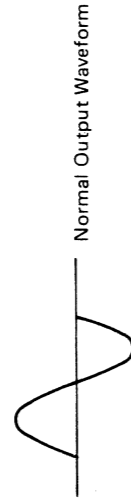

Fig. 9

Table 2

Adjustment Item	Input Side			Output Side			Adjustment Point	Adjustment Value	Remarks
	Measuring Instrument	Frequency	Input Level	Modulation	Connection Point	Measuring Instrument			
1 76 kHz	FM SSG	98.0 MHz	60 dBμ	Mono 1 kHz, 100%	Antenna Terminal	Frequency Counter	TP-3, 4	76 kHz ± 50 Hz	
2 Center Adjustment	FM SSG	98.0 MHz	60 dBμ	Mono 1 kHz, 100%	Antenna Terminal	Tuning Meter Jig	TP-1, 2	Tuning Meter Center	
3 Mono Distortion	FM SSG	98.0 MHz	60 dBμ	Mono 1 kHz, 100%	Antenna Terminal	Distortion Meter	Output (L)	Min. Distortion	
4 Stereo Distortion	FM SSG	98.0 MHz	60 dBμ	Stereo (L) Main 90% Pilot 10%	Antenna Terminal	Distortion Meter	Output (L)	Min. Distortion	
5 Repeat items 2 to 4 so that the tuning meter may indicate its center value, and the distortion is minimum at tuning time									
6 Noise Indicator LED ON Level	FM SSG	98.0 MHz	-3 dBμ	Mono 1 kHz, 100%	Antenna Terminal	-	-	5th Noise LED ON	By SSS controller in noise mode
7 Signal Indicator LED ON Level	FM SSG	98.0 MHz	55 dBμ	Mono 1 kHz, 100%	Antenna Terminal	-	-	5th Signal LED ON	By SSS controller in signal mode
8 Separation	FM SSG	98.0 MHz	60 dBμ	Stereo (L) Main 90% Pilot 10%	Antenna Terminal	Voltmeter	Output (L) Output (R)	Max. Separation (balance of directivity)	19/38 kHz L.P.F. is used

AM

1 IF Adjustment	No-broad-casting Frequency	AM IF Sweep	No-IF Waveform Distortion Level	-	AM Antenna Terminal	Monitor Scope	R208	Flat at Max. IF-Waveform	
2 522 kHz Tuning Voltage	522 kHz	-	-	-	-	Digital Voltmeter	R201	1.2 V ± 20 mV	
3 1611 kHz Tuning Voltage	1611 kHz	-	-	-	-	Digital Voltmeter	R201	8 V ± 100 mV	
4 Repeat items 2 and 3 to obtain rated tuning voltage									
5 603 kHz Tracking	603 kHz	AM SSG	Non-AGC Level	400 Hz, 30%	Loop Antenna	Voltmeter	Output (L)	T202	Adjust the SG output not over to work AGC
6 1404 kHz Tracking	1404 kHz	AM SSG	Non-AGC Level	400 Hz, 30%	Loop Antenna	Voltmeter	Output (L)	TC202	Adjust the SG output not over to work AGC
7 Repeat items 5 and 6 to adjust the tracking									
8 Signal Indicator LED ON Level	999 kHz	AM SSG	400 Hz, 30%	Loop Antenna	Loop Antenna	-	-	1st Signal LED ON	55 ± 10 dBμ/m

CONNECTION DIAGRAM OF MEASURING INSTRUMENTS

• FM

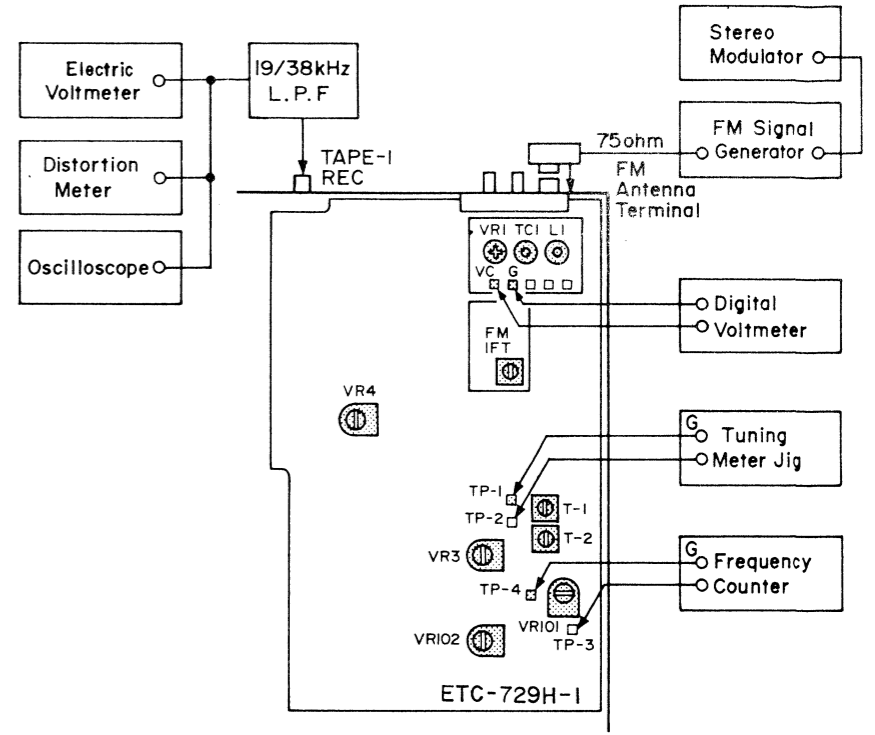

Fig. 10

• AM

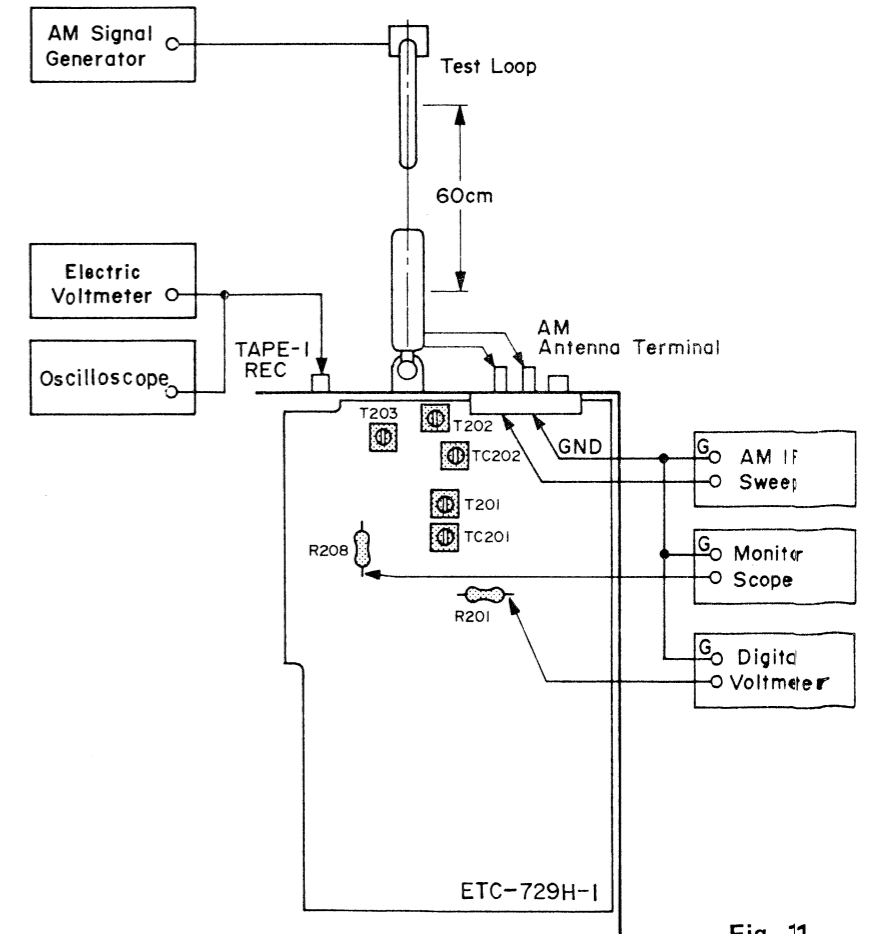

Fig. 11

ROUGH DIAGRAM OF ADJUSTMENT POINT
ETC0729H Tuner Unit (Component Side)

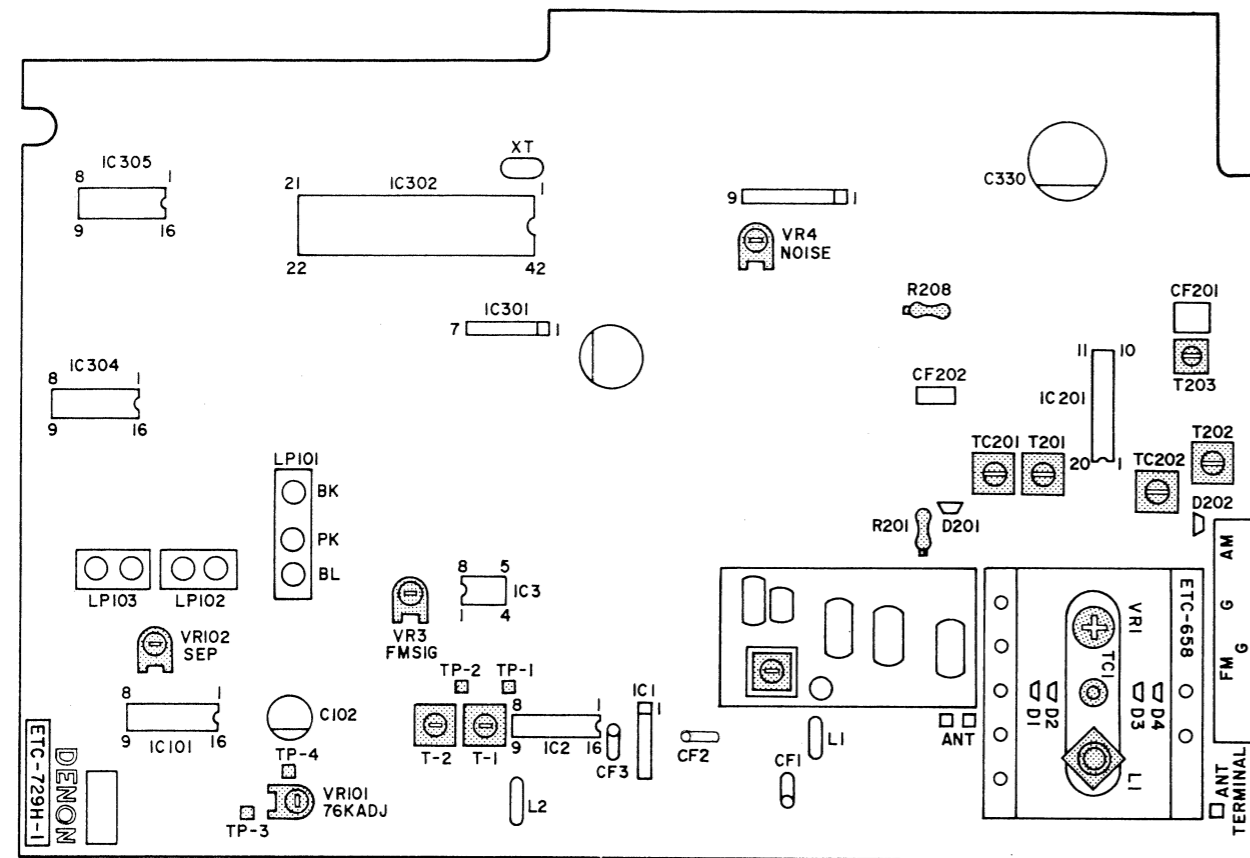

Fig. 12

TUNER METER JIG

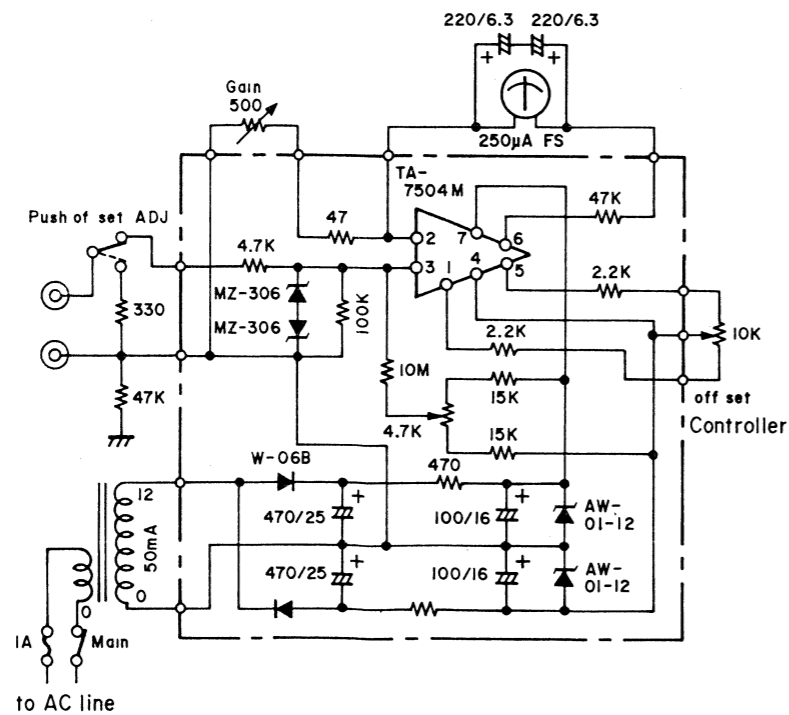
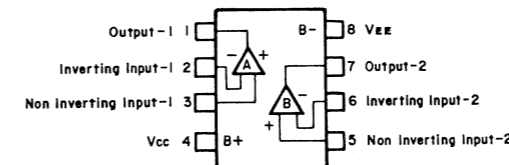
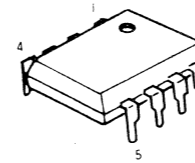

Fig. 13

SEMICONDUCTORS

• IC's

- NJM4558DD (JRC)
- NJM4558DX (JRC)
- NJM2041DD (JRC)
- M-5218P (Mitsubishi)



- HD14027B
- HA12016
- HA11225
- (Hitachi)

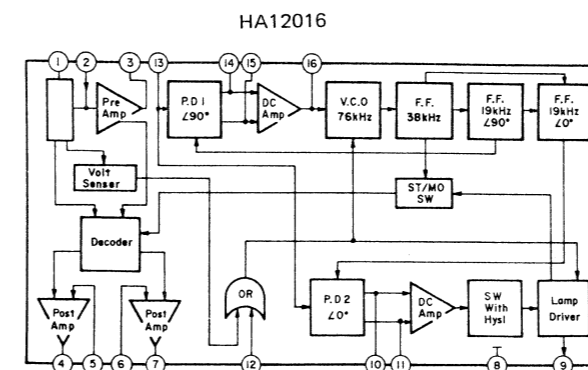
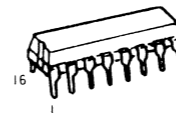

TA7060AP (Toshiba)

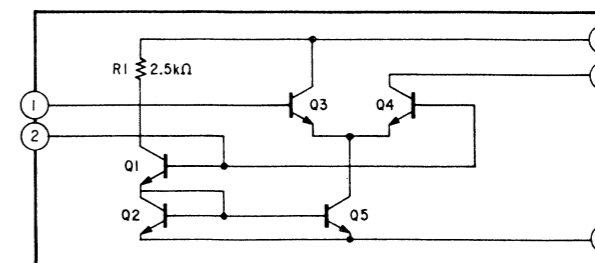
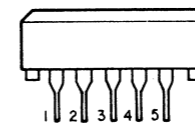

- NJM4558DD
- NJM4558DX
- NJM2041DD

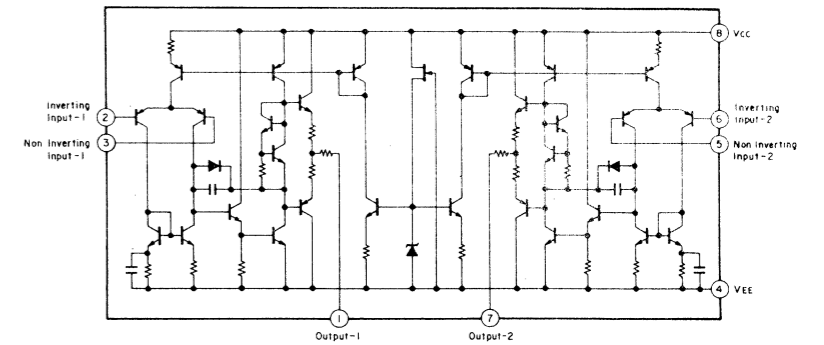

M-5218P

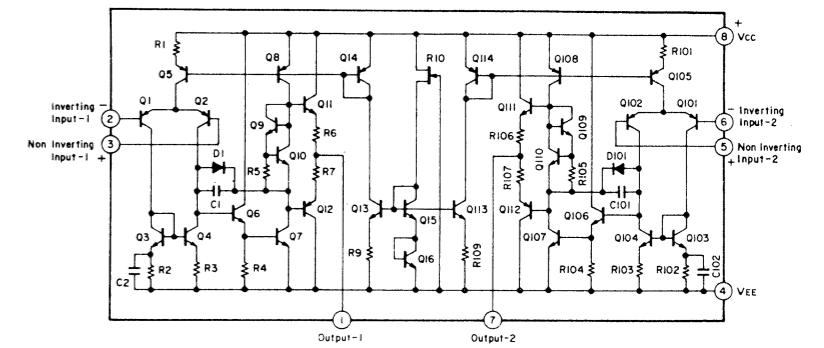

HD14027B

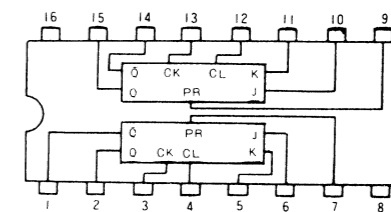

HA11225

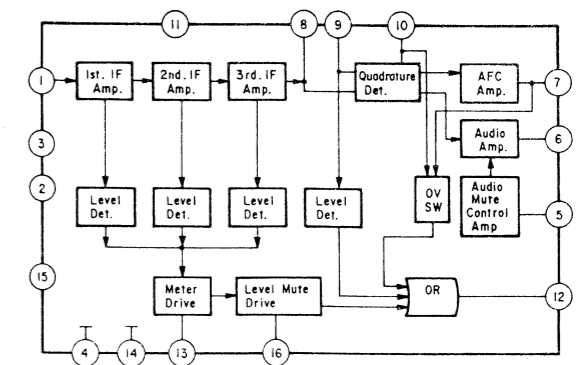

TD6301AP
(Toshiba)

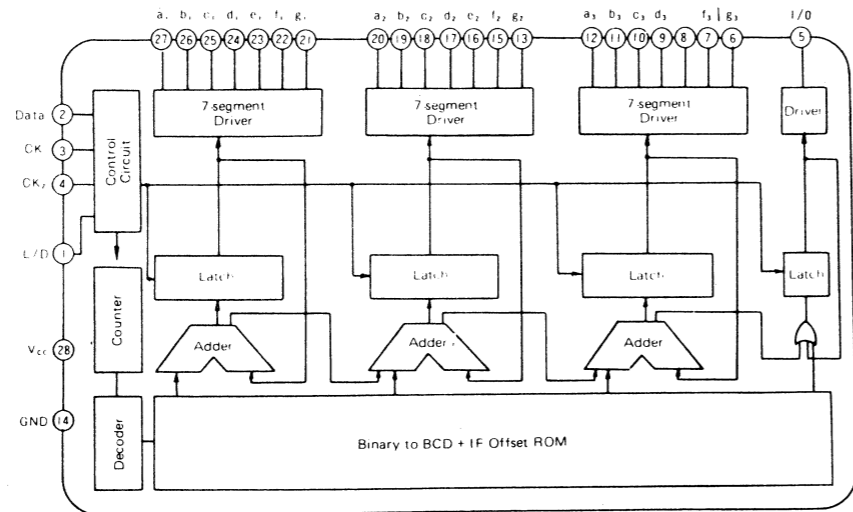
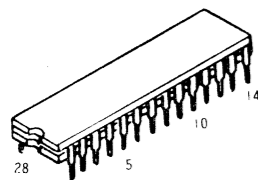

FUNCTIONS OF TERMINALS

Pin No.	Name	Function	Pin No.	Name	Function
1	L/D	Output status select input terminal. Input terminal for selecting output status by the indicator (LED, FL, LCD).	6~12	a ³ ~g ³	7-segment drive output terminal. 10 MHz-unit display at FM time. 100 kHz-unit display at AM time.
2	Data	Receiving frequency data input terminal. Input serially by the system controller LSI.	13, 15~20	a ² ~g ²	7-segment drive output terminal. 1 MHz-unit display at FM time. 10 kHz-unit display at AM time.
3, 4	CK1 CK2	Received frequency data input control timing input terminal. Transferred simultaneously with data by the system controller LSI.	21~27	a ¹ ~g ¹	7-segment drive output terminal. 100 kHz-unit display at FM time. 1 kHz-unit display at AM time.
5	1/0	Segment drive output terminal. 100 MHz-unit display at FM time. Only 1 pin is used for output because of 1 to 0 in both FM/AM.	14, 28	Vcc GND	Supply voltage applying terminal.

TD6104P
(Toshiba)

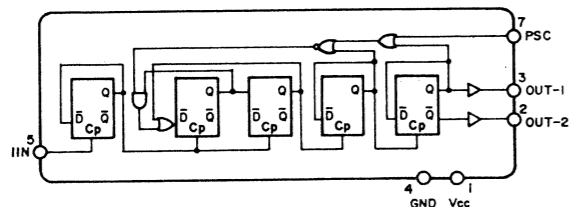
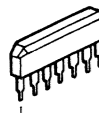

LB1403
(Sanyo)

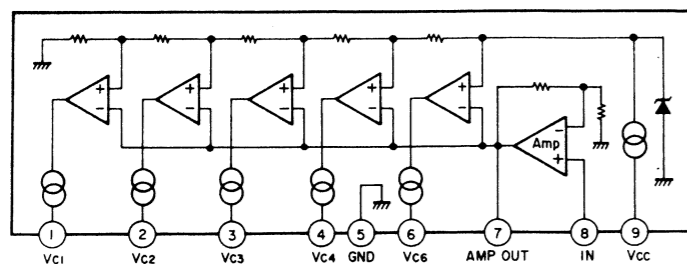
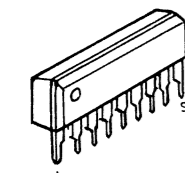

FUNCTIONS OF TERMINALS

Pin No.	Name	Functions
5	f _{IN}	FM station signal input terminal Frequency range 60 - 140 MHz Input level 75 - 300 mVrms
3	OUT-1	Dividing an input signal into 1/30 or 1/32 through dividing output terminal f _{IN} . Output level 0.5(V)MIN
2	OUT-2	OUT-1 inverted signal output. Because of open emitter system, if it is to be used. External resistor is necessary. Open in general.
7	PSC	Dividing value select control terminal 1/32 when V _{pcc} ≥ 2(V), 1/30 when V _{pcc} ≤ 1(V)
6	C	for bias circuit. Connect C = 2200 pF (approx.) between the unit and the GND.
1	Vcc	Power terminal Vcc = 5V Icc = 5 mA (standard), 10 mA (max.)
4	GND	

LA1245
(Sanyo)

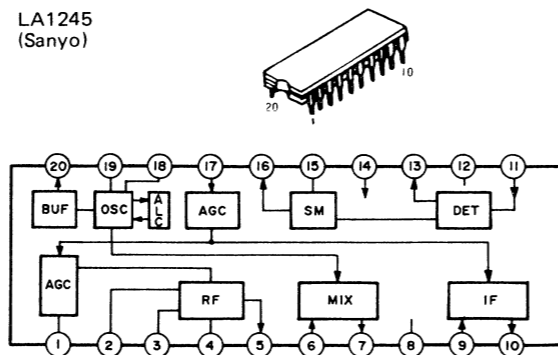

TC9147BP
(Toshiba)

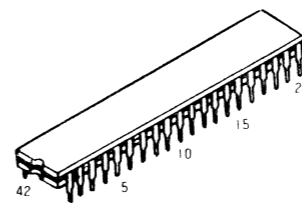

FUNCTIONS OF TERMINALS

Pin No.	Symbol	Name	Function
2	XT	Crystal oscillator terminal	Connects crystal 7.2 MHz for reference frequency.
3	XT	Crystal oscillator terminal	Connects crystal 7.2 MHz for reference frequency.
4	FM	FM band specifying input	Selects FM, MW and LW in the mutual reset mode.
5	MW	MW band specifying input	
6	LW	LW band specifying input	
7	MANUAL	Manual tuning mode specifying input	Selects between manual operation and auto search operation in mutual reset mode at UP/DOWN channel select time.
8	AUTO	Auto search tuning mode specifying input	Selects between manual operation and auto search operation in mutual reset mode at UP/DOWN channel select time.
9	UP	UP operation key input	UP/DOWN channel selection by connecting a push-key
10	DOWN	DOWN operation key input	
11	STO	Memory store instruction input	With this input, preset memory is set to write enable status.
12~19	M1~M8	Preset memory channel specifying input	Controls read/write of the internal 16-channel preset memory in conjunction with MC1 and MC2 input.
20	MC1	Memory control input	Sets the 16-channel preset memory to an 8-channel fixed system for FM/AM (MW + LW) or a 16-channel tandem system for FM+MW+LW (3 bands).
21	MC2		
22	OSC2	Oscillator terminal for AM	C/R connecting terminal for oscillator, which determines scan speed at AM search time.
23	OSC1	Oscillator terminal for FM	C/R connecting terminal for oscillator, which determines scan speed at FM search time.
24	0/5	FM Europe 50 kHz output	Europe area FM band 50 kHz step indicating output. Set "H" at 50 kHz.
25	CK2	Received frequency data serial output	Outputs serial data and timing lock to driver TD6301 for receiving frequency digital display. CK1 output is used as Pcc output at the same time.
26	CK1		
27	DATE		

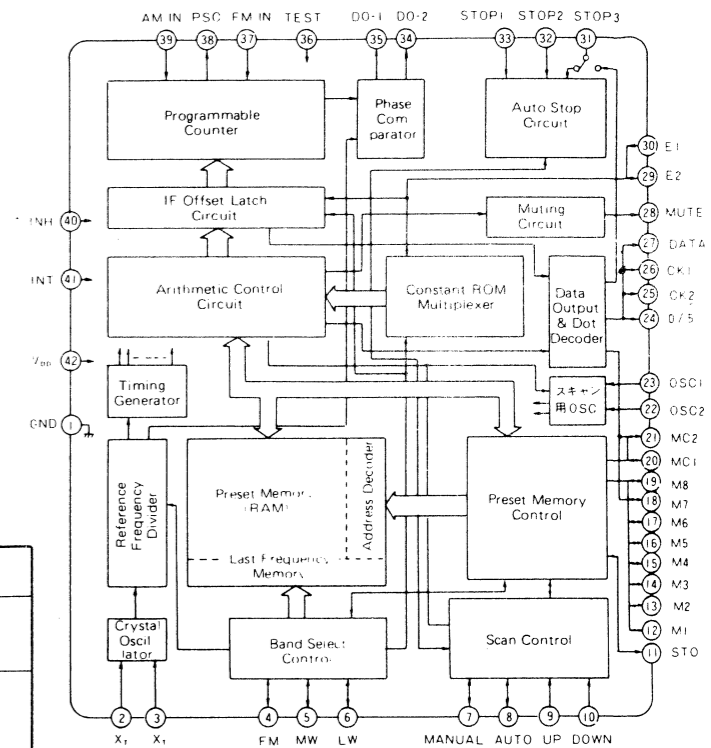

Pin No.	Symbol	Name	Function
28	MUTE	Muting signal output	Set "H" at muting output time.
29	E2	Area specify input	Specifies an area, Japan, U.S.A. or Europe.
30	E1		
31	STOP3	AM-IF signal input	Counts IF 450 kHz signals at AM time and stops auto search.
32	STOP2	Auto search stop signal input	If "H" level is input STOP2 when "H" level is set to STOP1, the auto search is stopped. Used for AR1 or stereo channel receiving status discrimination.
33	STOP1	Scan speed slow input	When "H" level is input, reduces the auto search scan speed to 1/2.
34	DO-2	Phase comparator output	Two tristate buffers are output in parallel from a single phase comparator.
35	DO-1		
36	TEST	Test terminal	Sets test mode with "H" level input.
37	FM _{IN}	FM programmable counter input	Connects the output of precaller TD6104P.
38	PSC	Prescaler control output	Controls dividing (1/30, 1/32) of the prescaler TD6104P.
39	AM _{IN}	FM programmable counter input	Inputs AM channel signal.
40	INH	Inhibit input	Ordinary operation at "H" level, and inhibit status at "L" level.
41	INT	Initialize input	Ordinary operation at "H" level, and initialization of internal status at "L" level.
42	VDD GND	Power applying terminal	Applies 5 ± 0.5 V. Up to 2 V is available as backup.

• TRANSISTORS

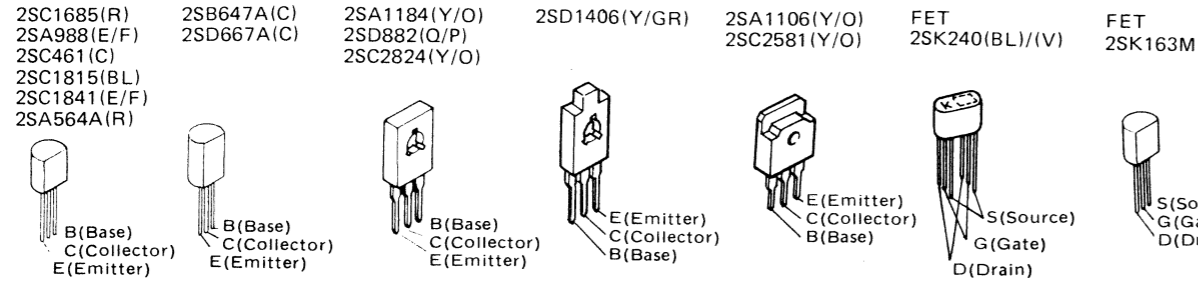

• DIODES (including LED)

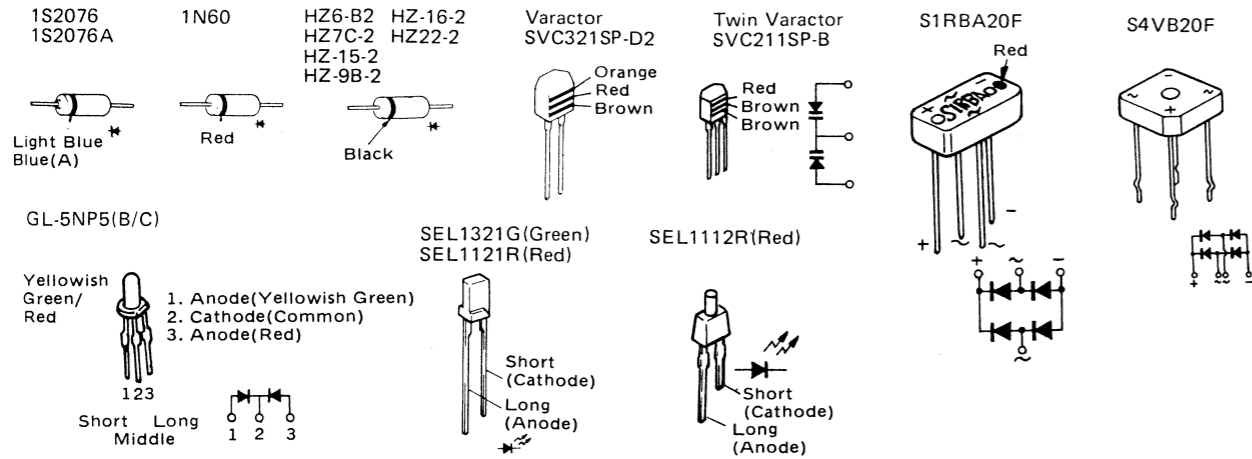

• ELECTRON RAY INDICATOR TUBE

FIP7F8S

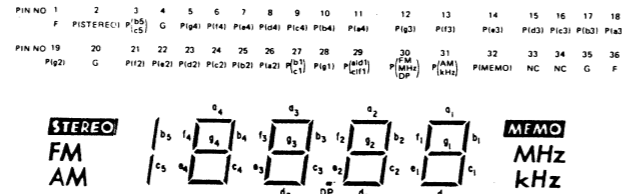
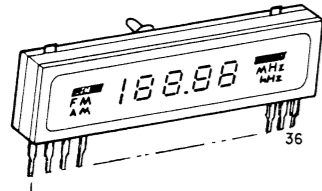

OPERATING PRINCIPLE OF THE SSS (SUPER SEARCHER SYSTEM)

When radio signals of more than two stations on one band enter, a false radio wave will arise at another point. (Assuming two stations.) This false wave causes intermodulation interference. If receiving a station with the same frequency of the false radio wave, reception is accompanied by intermodulation interference noise, and various other interference.

Fig.14 shows how intermodulation interference occurs, and how to make interference-free reception. Two false radio waves, D1 and D2, arise each from one of two radio wave frequencies of stations (A and B). These false waves cause intermodulation interference for reception with station C. If station C's frequency is the same as false frequency D1, it is normally impossible to isolate the false wave. But with the DRA-750, the band eliminate filter, removes false radio wave D1 and D2 from station A or B. Therefore, any audio system employing this Model is assured of quality reception, free from intermodulation interference.

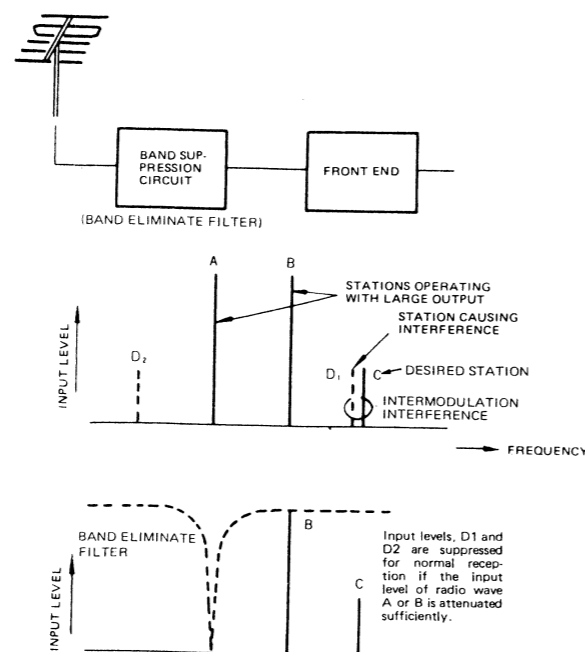
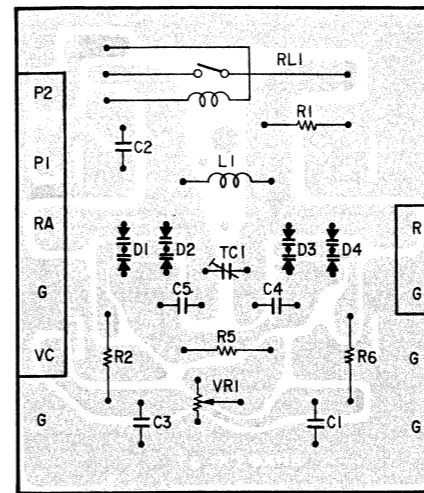

Fig. 14

PRINTED WIRING BOARD PATTERNS AND PARTS LIST

ETC0658J TRAP UNIT



ETC0658J TRAP UNIT PARTS LIST

Ref. No.	Part No.	Part Name & Descriptions
SEMICONDUCTORS		
R001, 002	2412148008	220k ohm ±5% 1/4W CARBON
R005	2412089002	750 ohm ±5% 1/4W CARBON
R006	2412148008	220k ohm ±5% 1/4W CARBON
VR001	EP-5462H11	SOLID VR 4.7k ohm
RESISTORS		
C002, 003	2531024003	0.01µF +80,-20% 50V CERAMIC
C004, 005	2533469006	10pF ±0.5pF 50V CERAMIC
TC001	2130034009	TRIMMER CON. (CTZ-51C)
CAPACITORS		
OTHER PARTS		
RL001	2221003004	P.W. BOARD
L001	4140328004	SHIELD CASE
	2140052000	REED RELAY (L13M)
	RT-11653	FM OSC COIL
	2050087026	2P TERMINAL
	2050087055	5P TERMINAL

NOTE: If D001, D002, D003 and D004 are to be replaced, be sure to replace them in pairs.

ETC0729H TUNER UNIT PARTS LIST

Ref. No.	Part No.	Part Name & Descriptions
SEMICONDUCTORS		
IC001	2630099007	TA-7060AP IC (TOSHIBA)
IC002	2630083000	HA11225 IC (HITACHI)
IC003	2650030004	NJM4558DD IC (JRC)
IC101	2630123009	HA-12016 IC (HITACHI)
IC201	2630145003	LA1245 IC (SANYO)
IC301	2630232000	TD6104P IC (TOSHIBA)
IC302	2620452104	TC9147BP IC (TOSHIBA)
IC303	2630221008	LB1403 IC (SANYO)
IC304, 305	2620343006	HD14027B IC (HITACHI)
TR001	2730025023	2SC461(C) TRANSISTOR
TR002	2730294016	2SC1685(R) TRANSISTOR
TR101	2730294016	2SC1685(R) TRANSISTOR
TR301	2730294016	2SC1685(R) TRANSISTOR
TR302	2750020008	2SK163(M) FET
TR303	2730294016	2SC1685(R) TRANSISTOR
TR304	2710178039	2SA564A(R) TRANSISTOR
TR305	2730294016	2SC1685(R) TRANSISTOR
TR308	2710178039	2SA564A(R) TRANSISTOR
TR320	2730294016	2SC1685(R) TRANSISTOR
TR328	2710178039	2SA564A(R) TRANSISTOR
TR329	2730294016	2SC1685(R) TRANSISTOR
TR330	2710178039	2SA564A(R) TRANSISTOR
TR331	2730294016	2SC1685(R) TRANSISTOR
TR332	2740078031	2SD882(Q/P) TRANSISTOR
TR333	2740088018	2SD1406(Y)/(GR) TRANSISTOR
TR334	2730294016	2SC1685(R) TRANSISTOR
TR337	2710178039	2SA564A(R) TRANSISTOR
D005, 006	2760049011	1S2076A DIODE
D007, 008	2760002003	1N60 DIODE
D009	2760049011	1S2076A DIODE
D101, 102	2760049011	1S2076A DIODE
D201, 202	2760302004	SVC321SP-D2 VARACTOR
D203	2760049011	1S2076A DIODE
D301	2760049011	1S2076A DIODE
D304	2760218033	HZ9B2 ZENER
D305	2760173039	HZ6-B2 ZENER
D306	2760049011	1S2076A DIODE
D320	2760256008	HZ-16-2 ZENER
D321	2760051070	HZ7C-2 ZENER
D322	2760239009	S1RBA20F DIODE
D323	2760049011	1S2076A DIODE
D330	2760049011	1S2076A DIODE
D351	3939237006	GL5NP5(B/C) (RED/GREEN) LED
D356	3939261014	SEL1321G (GREEN) LED
RESISTORS (not included Carbon Film ±5%, 1/4W Type)		
ΔR123	2412321061	47 ohm ±5% 1/4W CARBON (NB)
ΔR311	2440031022	150 ohm ±5% 1W METAL OXIDE FILM (NB)
ΔR334	2412314052	82 ohm ±5% 1/4W CARBON (NB)
ΔR364	2412314023	470 ohm ±5% 1/4W CARBON (NB)

Ref. No.	Part No.	Part Name & Descriptions
AR375, 376	2440005029	1 ohm ±5% 1W METAL OXIDE FILM (NB)
VR002	2110404002	PUSH LOCK VR 100k ohm
VR003, 004	2116000073	SEMI FIXED RESISTOR 20k ohm
VR101	2116000099	SEMI FIXED RESISTOR 2k ohm
VR102	2116000086	SEMI FIXED RESISTOR 200k ohm

CAPACITORS (not included Ceramic ±5%, ±10%, 50V Type)

C006	2551072006	0.01 μF ±10% 50V PLASTIC FILM
C007	2531024003	0.01 μF +80,-20% 50V CERAMIC
~009		
C011	2531024003	0.01 μF +80,-20% 50V CERAMIC
C014	2531024003	0.01 μF +80,-20% 50V CERAMIC
~017		
C019	2531024003	0.01 μF +80,-20% 50V CERAMIC
C020	2544145005	0.47 μF 50V ELECTROLYTIC
C021	2531025002	0.022 μF +80,-20% 50V CERAMIC
C022	2531024003	0.01 μF +80,-20% 50V CERAMIC
C024	2544146004	1 μF 50V ELECTROLYTIC
C025	2531024003	0.01 μF +80,-20% 50V CERAMIC
026		
C027	2544136001	100 μF 16V ELECTROLYTIC
C032, 033	2544145005	0.47 μF 50V ELECTROLYTIC
C034	2544146004	1 μF 50V ELECTROLYTIC
C036, 037	2531024003	0.01 μF +80,-20% 50V CERAMIC
C101	2544148002	3.3 μF 50V ELECTROLYTIC
C102	2544021006	470 μF 16V ELECTROLYTIC
C103, 104	2544132005	10 μF 16V ELECTROLYTIC
C105	2544148002	3.3 μF 50V ELECTROLYTIC
C106	2544146004	1 μF 50V ELECTROLYTIC
C107	2544148002	3.3 μF 50V ELECTROLYTIC
C108	2544146004	1 μF 50V ELECTROLYTIC
C109	2551122008	0.047 μF ±5% 50V PLASTIC FILM
C110	2556099000	0.001 μF ±5% 50V PLASTIC FILM
C111	2544148002	3.3 μF 50V ELECTROLYTIC
C112, 113	2544133004	22 μF 16V ELECTROLYTIC
C114, 115	2551120013	0.0012 μF ±5% 50V PLASTIC FILM
C116, 117	2544148002	3.3 μF 50V ELECTROLYTIC
C118, 119	2544089006	1 μF ±20% 50V ELECTROLYTIC
C201	2531024003	0.01 μF +80,-20% 50V CERAMIC
C202	2533603008	10 pF ±0.5 pF 50V CERAMIC
C203	2556089007	390 pF ±5% 50V PLASTIC FILM
C204	2531024003	0.01 μF +80,-20% 50V CERAMIC
C205	2533600001	7 pF ±0.5 pF 50V CERAMIC
C206, 207	2531024003	0.01 μF +80,-20% 50V CERAMIC
C208	2531026001	0.047 μF +80,-20% 50V CERAMIC
C209	2544140000	4.7 μF 35V ELECTROLYTIC
C210, 211	2531024003	0.01 μF +80,-20% 50V CERAMIC
C212	2544146004	1 μF 50V ELECTROLYTIC
C213	2544147003	2.2 μF 50V ELECTROLYTIC
C214	2531024003	0.01 μF +80,-20% 50V CERAMIC
C215	2551076002	0.022 μF ±10% 50V PLASTIC FILM
C216, 217, 218	2544163003	220 μF 16V ELECTROLYTIC
C219	2531024003	0.01 μF +80,-20% 50V CERAMIC
C220	2544132005	10 μF 16V ELECTROLYTIC
C221	2531024003	0.01 μF +80,-20% 50V CERAMIC
C222	2544136001	100 μF 16V ELECTROLYTIC

ETC0729H TUNER UNIT

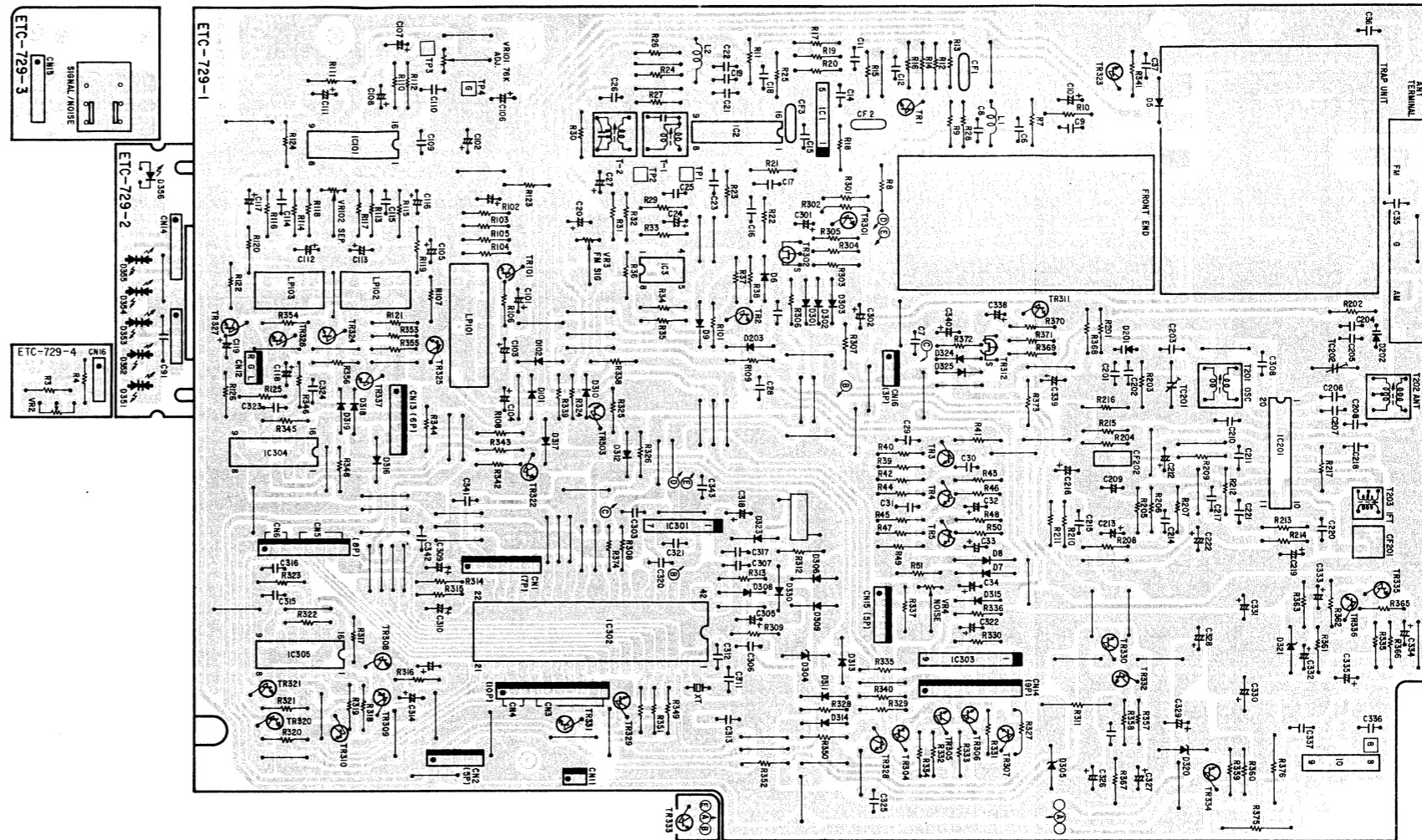

Ref. No.	Part No.	Part Name & Descriptions
C301	2541029001	1 μF ±20% 35V TANTALUM
C302	2544139008	100 μF 25V ELECTROLYTIC
C303	2551072006	0.01 μF ±10% 50V PLASTIC FILM
C304	-	-
C305	2544161047	470 μF 6.3V ELECTROLYTIC
C306	2531024003	0.01 μF +80,-20% 50V CERAMIC
C309, 310	2544147003	2.2 μF 50V ELECTROLYTIC
C313	2531024003	0.01 μF +80,-20% 50V CERAMIC
C314	2544017007	47 μF 16V ELECTROLYTIC
C315, 316	2531025002	0.022 μF +80,-20% 50V CERAMIC
C317	2531024003	0.01 μF +80,-20% 50V CERAMIC
C318	2544129005	47 μF 10V ELECTROLYTIC
C320, 321	2531024003	0.01 μF +80,-20% 50V CERAMIC
C322	2544140000	4.7 μF 35V ELECTROLYTIC
C323, 324	2531025002	0.022 μF +80,-20% 50V CERAMIC
C325	2531024003	0.01 μF +80,-20% 50V CERAMIC
C326	2544136001	100 μF 16V ELECTROLYTIC
~328		
C329	2544029008	220 μF 25V ELECTROLYTIC
C330	2544086009	2200 μF ±20% 25V ELECTROLYTIC
C331	2544159004	100 μF 35V ELECTROLYTIC
C332	2544132005	10 μF 16V ELECTROLYTIC

Ref. No.	Part No.	Part Name & Descriptions
C333	2544148002	3.3 μF 50V ELECTROLYTIC
C334, 335	2544059049	22 μF 63V ELECTROLYTIC
C336, 337	2531024003	0.01 μF +80,-20% 50V CERAMIC
C341, 342	2531026001	0.047 μF +80,-20% 50V CERAMIC
TC201, 202	2130022008	TRIMMER CONDENSER
COILS, TRANS		
T001	2312901002	FM IF DET (A) (50kHz)
T002	2312902001	FM IF DET (B) (50kHz)
T201	2311076103	MW OSC COIL
T202	2311061008	MW ANT TRANS
T203	2310056001	AM IFT
LP101	2320069004	ANTI BIRDIE FILTER (114kHz)
LP102, 103	2320041006	LOW PASS FILTER (19kHz, 38kHz)
CF001	2610038004	FM C. FILTER (10.7M A8)
CF002, 003	2610023006	FM C. FILTER (SFE10.7MHz A)
CF201	2610034008	AM C. FILTER (SEP450H)
CF202	2610031001	AM C. FILTER (BFU450C4)
XT	3990008038	X-TAL (7.2MHz)

Ref. No.	Part No.	Part Name & Descriptions	
L001, 002	2350015043	INDUCTOR (2.2mH)	
	2169002002	FRONT END	
OTHER PARTS			
	2221080108	P.W. BOARD	1
	EP-5667H1	TERMINAL PIN	9
	2090008120	JUMPER WIRE P=10mm	86
	2050190023	2P NH CONNECTOR BASE	1
	2050190036	3P NH CONNECTOR BASE	2
	2050190052	5P NH CONNECTOR BASE	2
	2050190065	6P NH CONNECTOR BASE	1
	2050190078	7P NH CONNECTOR BASE	1
	2050190081	8P NH CONNECTOR BASE	1
	2050190094	9P NH CONNECTOR BASE	1
	2050190007	10P NH CONNECTOR BASE	1
	2050241037	3P CONNECTOR PIN ASS'Y	1
	2050185038	3P WIRE HOL DER	3
	2050185041	4P WIRE HOLDER	1
	2050185054	5P WIRE HOLDER	2
	2030225060	1P CONTACT ASS'Y	1
	2034203062	3P CONNECTOR CORD	1
	2038109010	5P CONNECTOR CORD	1
	2042093002	9P CONNECTOR CORD	1
	2124458002	SLIDE SW (SCL-202)	1
	2050208009	3P NJ ANT TERMINAL	1
	3940005007	LITHIUM BATTERY	1

ETC0730Q CONTROL UNIT

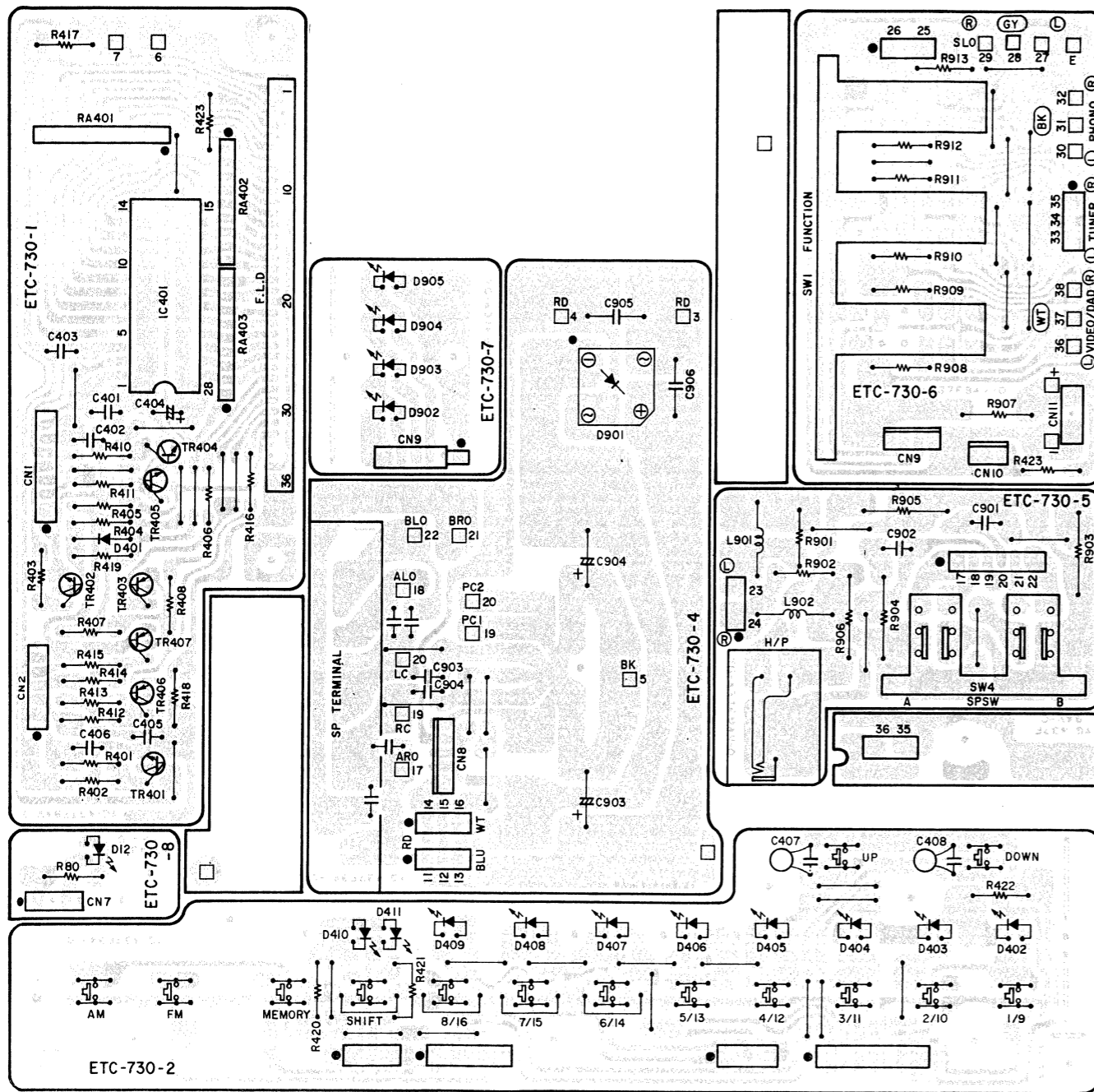

ETC0730Q CONTROL UNIT PARTS LIST

Ref. No.	Part No.	Part Name & Descriptions	
SEMICONDUCTORS			
IC401	2620453006	TD6301AP	IC (TOSHIBA)
TR401, 402	2730294016	2SC1685(R)	TRANSISTOR
TR403	2710178039	2SA564A(R)	TRANSISTOR
TR404, 405	2730294016	2SC1685(R)	TRANSISTOR
TR406, 407	2710178039	2SA564A(R)	TRANSISTOR

Ref. No.	Part No.	Part Name & Descriptions	
D402 ~409	3939261001	SEL1121R(RED)	LED
D410, 411	3939260002	SEL1112R(RED)	LED
D901	2760338007	S4VB20F	DIODE
D902 ~905	3939261014	SEL1321G(GREEN)	LED
	3934009019	FIP7F8S DISPLAY	

ETC9028 POWER PRE UNIT PARTS LIST

Ref. No.	Part No.	Part Name & Descriptions	
RESISTORS			
R401 ~404	2412130003	39k ohm ±5%	1/4W CARBON
R405 ~409	2412116001	10k ohm ±5%	1/4W CARBON
R410 ~415	2412130003	39k ohm ±5%	1/4W CARBON
R416	2412116001	10k ohm ±5%	1/4W CARBON
R417, 418	2412076002	220 ohm ±5%	1/4W CARBON
R419	2412130003	39k ohm ±5%	1/4W CARBON
R420	2412087004	620 ohm ±5%	1/4W CARBON
R421	2412108006	4.7k ohm ±5%	1/4W CARBON
R422	2412087004	620 ohm ±5%	1/4W CARBON
R423	2412110007	5.6k ohm ±5%	1/4W CARBON
R901, 902	2412060005	47 ohm ±5%	1/4W CARBON
ΔR903, 904	2440021029	22 ohm ±5%	1W METAL OXIDE FILM (NB)
ΔR905, 906	2440033020	220 ohm ±5%	1W METAL OXIDE FILM (NB)
RA401 ~403	2462012003	10k ohm x 8 ±20%	1/8W RESISTOR ARRAY
CAPACITORS			
C401 ~403	2531006005	2200pF ±10%	50V CERAMIC
C407	2533633007	180pF ±5%	50V CERAMIC
C901, 902	2551121067	0.022μF ±5%	50V PLASTIC FILM
C903, 904	2546074006	10,000μF ±20%	63V ELECTROLYTIC
C905	2531053003	0.01μF +100,-0%	500V CERAMIC
C951 ~954	2531008003	4700pF ±10%	50V CERAMIC
SWITCHES, COILS			
L901, 902	2124407008	TACT SWITCH (USED 14)	
	2124499003	2P PUSH SWITCH (SP A/B)	
	2359001004	INDUCTOR (1μH)	
OTHER PARTS			
PL001	2221081204	P.W. BOARD	1
	EP-5667H1	TERMINAL PIN L=21	16
	2090008120	JUMPER WIRE P=10mm	31
	2050151004	8P PUSH TERMINAL (SP OUTPUT)	1
	3930064003	PILOT LAMP	1
	1460703108	LED GUIDE	1
	2048100009	HEADPHONE JACK	1
	4770210016	PUSH RIVET	3
	2050185038	3P WIRE HOLDER	5
	2050185041	4P WIRE HOLDER	1
	2050185054	5P WIRE HOLDER	2
	2050185067	6P WIRE HOLDER	1
	2050185070	7P WIRF HOLDER	2
	2050190052	5P NH CONNECTOR BASE	1
	2032154016	2P CONNECTOR CORD	1
	2038109007	5P CONNECTOR CORD	1
	2038109078	5P CONNECTOR CORD	1
	2042052001	7P CONNECTOR CORD	1
	2042096009	8P CONNECTOR CORD	1
	2042090005	10P CONNECTOR CORD	1

Ref. No.	Part No.	Part Name & Descriptions	
SEMICONDUCTORS			
IC501	2630081015	NJM4558DX	IC (JRC)
IC502	2630205008	NJM2041DD	IC (JRC)
IC503, 504	2630257001	M-5218P	IC (MITSUBISHI)
TR501, 502	2750029025	2SK240(BL)/(V)	FET
TR511, 512	2710131021	2SA988(E/F)	TRANSISTOR
TR513, 514	2730235020	2SC1841(E/F)	TRANSISTOR
TR515, 516	2710131021	2SA988(E/F)	TRANSISTOR
TR517 ~520	2730235020	2SC1841(E/F)	TRANSISTOR
TR521, 522	2710131021	2SA988(E/F)	TRANSISTOR
TR523, 524	2730198015	2SC1815(BL)	TRANSISTOR
TR525, 526	2730236029	2SC2824(Y/O)	TRANSISTOR
TR527, 528	2710135027	2SA1184(Y/O)	TRANSISTOR
TR529, 530	2730273011	2SC2581(O)/(Y)	TRANSISTOR
TR531, 532	2710160018	2SA1106(O)/(Y)	TRANSISTOR
TR601, 602	2730198015	2SC1815(BL)	TRANSISTOR
TR603	2740060007	2SD667A(C)	TRANSISTOR
TR605	2720053005	2SB647A(C)	TRANSISTOR
TR606, 607	2730294016	2SC1685(R)	TRANSISTOR
D501 ~508	2760049011	1S2076A	DIODE
D509 ~512	2760253001	HZ15-2	ZENER
D513 ~524	2760049011	1S2076A	DIODE
D525, 526	2760049008	1S2076	DIODE
D601, 602	2760049011	1S2076A	DIODE
D603, 604	2760301005	HZ22-2	ZENER
RESISTORS (not included Carbon Film ±5%, 1/4W Type)			
ΔR068, 069	2412321032	4.7 ohm ±5%	1/4W CARBON (NB)
R541	2410177000	470 ohm ±5%	1/2W CARBON
R557	2410181009	680 ohm ±5%	1/2W CARBON
ΔR560	2412321016	22 ohm ±5%	1/4W CARBON (NB)
ΔR627 ~630	2412314081	560 ohm ±5%	1/4W CARBON (NB)
ΔR631 ~634	2412314007	100 ohm ±5%	1/4W CARBON (NB)
ΔR635 ~638	2412321061	47 ohm ±5%	1/4W CARBON (NB)
ΔR701 ~704	2440103028	2.7k ohm ±5%	2W METAL OXIDE FILM (NB)
ΔR705, 706	2412321003	1k ohm ±5%	1/4W CARBON (NB)
ΔR709, 710	2412321003	1k ohm ±5%	1/4W CARBON (NB)
ΔR723 ~726	2412321003	1k ohm ±5%	1/4W CARBON (NB)
ΔR731, 732	2412314081	560 ohm ±5%	1/4W CARBON (NB)

Ref. No.	Part No.	Part Name & Descriptions
ΔR733 ~740	2442013093	0.33 ohm ±5% 1W METAL OXIDE FILM (NB)
ΔR747, 748	2440021029	22 ohm ±5% 1W METAL OXIDE FILM (NB)
ΔR803, 804	2440038025	560 ohm ±5% 1W METAL OXIDE FILM (NB)
ΔR812	2412314010	390 ohm ±5% 1/4W CARBON (NB)
VR501, 502	EP-5462H1	100 ohm SOLID VR
VR503, 504	2116028000	10k ohm SEMI FIXED RESISTOR
VR505, 506	2116028013	200 ohm SEMI FIXED RESISTOR
VR507	2110433002	100k ohm VARIABLE RESISTOR
VR508	2110432100	100k ohm VARIABLE RESISTOR
VR509	2110434001	250k ohm VARIABLE RESISTOR
VR510	2110435000	50k ohm VARIABLE RESISTOR
VR511	2110435013	250k ohm VARIABLE RESISTOR

CAPACITORS (not included Ceramic ±5%, ±10%, 50V Type)

C501 ~504	2544146004	1μF 50V ELECTROLYTIC
C521	2544136001	100μF 16V ELECTROLYTIC
C523, 524	2549012023	47μF 16V ELECTROLYTIC
C525, 526	2551122024	0.068μF ±5% 50V PLASTIC FILM
C527, 528	2551120000	0.001μF ±5% 50V PLASTIC FILM
C529, 530	2551121054	0.018μF ±5% 50V PLASTIC FILM
C533	2531025002	0.022μF +80,-20% 50V CERAMIC
C535	2531025002	0.022μF +80,-20% 50V CERAMIC
C551, 552	2549014018	0.22μF ±20% 50V ELECTROLYTIC
C555, 556	2551121067	0.022μF ±5% 50V PLASTIC FILM
C557, 558	2544146004	1μF 50V ELECTROLYTIC
C563, 564	2544132005	10μF 16V ELECTROLYTIC
C565, 566	2533603008	10pF ±0.5pF 50V CERAMIC
C567	2544146004	1μF 50V ELECTROLYTIC
C569	2544146004	1μF 50V ELECTROLYTIC
C571 ~574	2544180028	10μF ±20% 63V ELECTROLYTIC
C579 ~582	2534285001	47pF ±5% 500V CERAMIC
C583 ~588	2544146004	1μF 50V ELECTROLYTIC
C589	2544203002	1μF ±20% 160V ELECTROLYTIC
C590	2531024003	0.01μF +80,-20% 50V CERAMIC
C591	2544203002	1μF ±20% 160V ELECTROLYTIC
C593	2544203002	1μF ±20% 160V ELECTROLYTIC
C595	2544203002	1μF ±20% 160V ELECTROLYTIC
C597, 598	2551121041	0.015μF ±5% 50V PLASTIC FILM
C599, 600	2551122053	0.12μF ±5% 50V PLASTIC FILM
C603, 604	2551121009	0.0068μF ±5% 50V PLASTIC FILM
C607, 608	2551122011	0.056μF ±5% 50V PLASTIC FILM
C609	2544151002	22μF 50V ELECTROLYTIC
C619, 620	2544132005	10μF 16V ELECTROLYTIC
C625, 626	2534285001	47pF ±5% 500V CERAMIC
C627, 628	2534283003	39pF ±5% 500V CERAMIC

ETC9028 POWER PRE UNIT

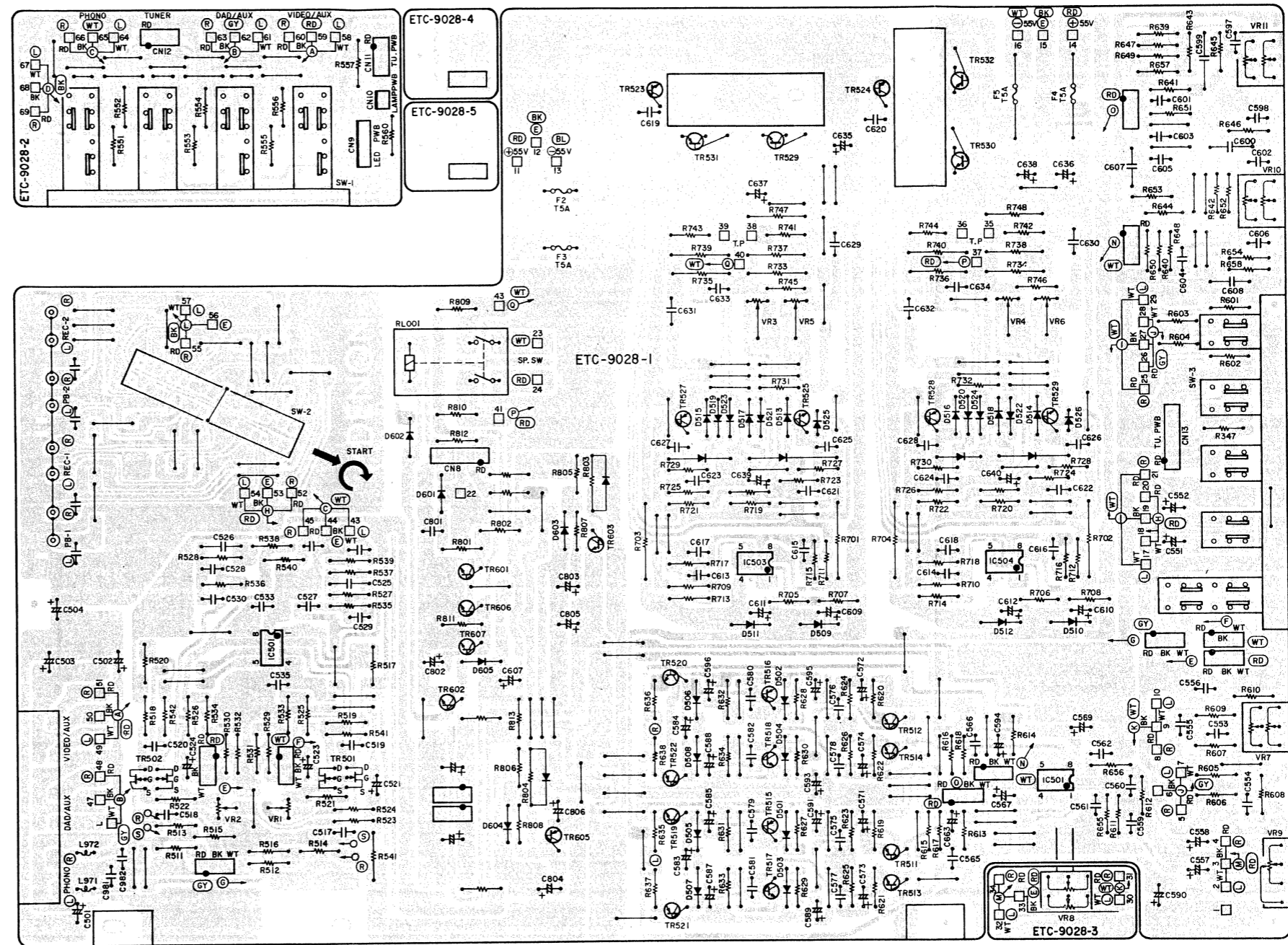

Ref. No.	Part No.	Part Name & Descriptions
C629 ~632	2551121067	0.022μF ±5% 50V PLASTIC FILM
C633, 634	2551121025	0.01μF ±5% 50V PLASTIC FILM
C635 ~638	2544203002	1μF ±20% 160V ELECTROLYTIC
C639, 640	2544146004	1μF 50V ELECTROLYTIC
C801	2544181001	1μF ±20% 100V ELECTROLYTIC
C802	2544127007	220μF 6.3V ELECTROLYTIC
C803, 804	2544089022	100μF 50V ELECTROLYTIC
C805, 806	2544146004	1μF 50V ELECTROLYTIC
C807	2544163003	220μF 16V ELECTROLYTIC
SWITCH, RELAY, COIL		
RL001	2140037009	RELAY

Ref. No.	Part No.	Part Name & Descriptions	
L971, 972	2359003002	FTZ CHOKE COIL	
	2124254002	SLIDE SW (REMOTE)	
	2124503009	INPUT SELECTOR SW.	
	2124500002	5P PUSH SWITCH	
OTHER PARTS			
F502 ~505	2229035003	P.W. BOARD	1
	EP-5667H1	TERMINAL PIN L=21	62
	2090008146	JUMPER WIRE P=5	3
	2090008120	JUMPER WIRE P=10	116
	2020022008	FUSE HOLDER	8
	2061040036	FUSE 5A F	4
	4140240001	EARTH PLATE	2
	4170234003	RADIATOR BLOCK	2
	2050185038	3P WIRE HOLDER	12
	5139119032	FUSE LABEL 5AF	4

Ref. No.	Part No.	Part Name & Descriptions	
	2050185054	5P WIRE HOLDER	1
	2050185067	6P WIRE HOLDER	1
	2050133022	2P NH CONNECTOR BASE	1
	2050133051	5P NH CONNECTOR BASE	1
	2050152003	6P CONNECTOR BASE	1
	2050150005	4P CONNECTOR BASE	2
	2030241057	1P CONTACT ASS'Y	1
	2032115000	2P CONNECTOR CORD	1
	2034203075	3P CONNECTOR CORD	1
	2038123038	5P CONNECTOR CORD	1
	2040094029	6P CONNECTOR	1
	4700012022	CROSS PAN SCREW WITH S, WASHER 3x12	4
	4737002018	TAPPING SCREW (S) 3x8	4
	4159001008	F.S. WASHER	4

WIRING DIAGRAM

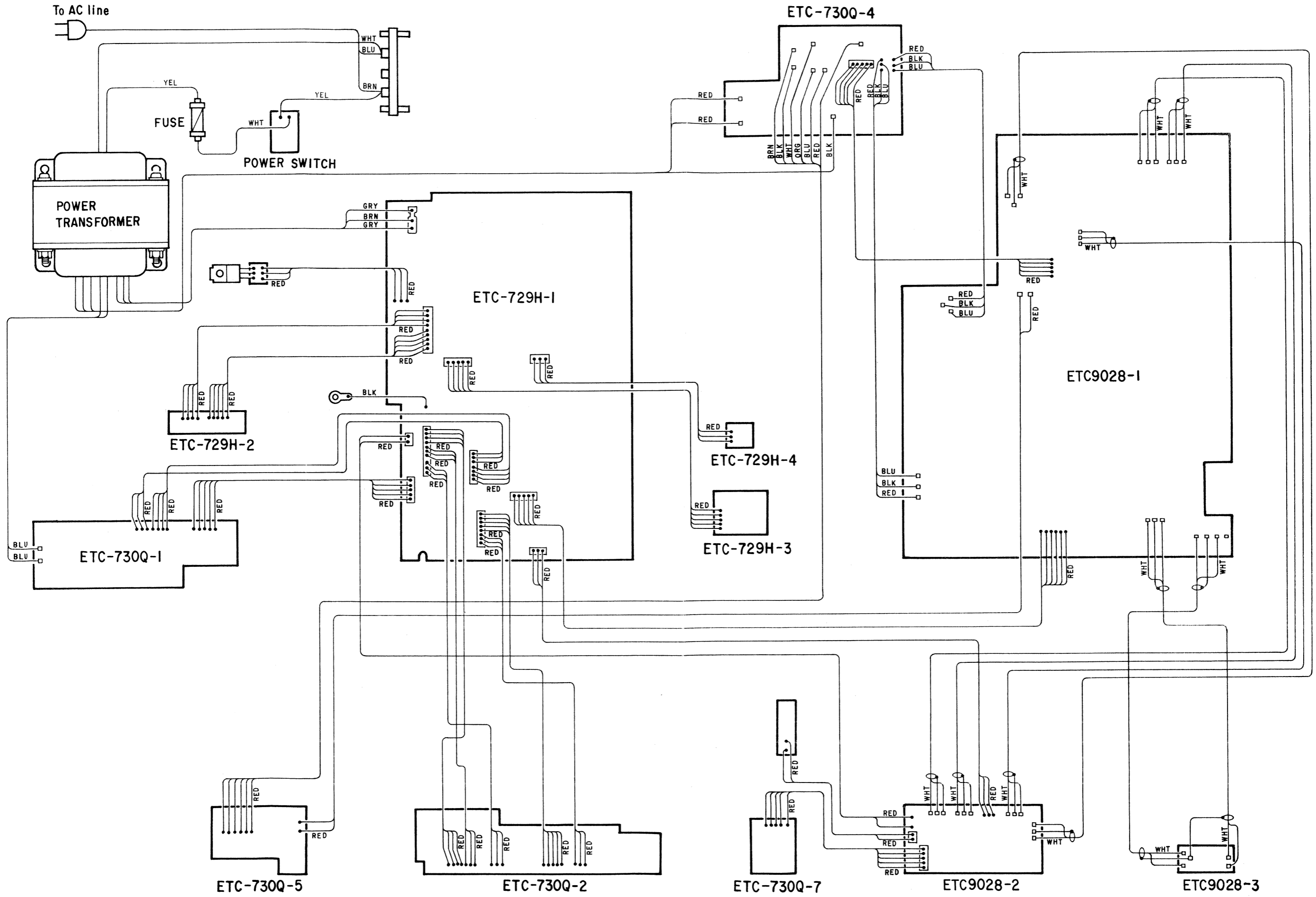

SCHEMATIC DIAGRAM

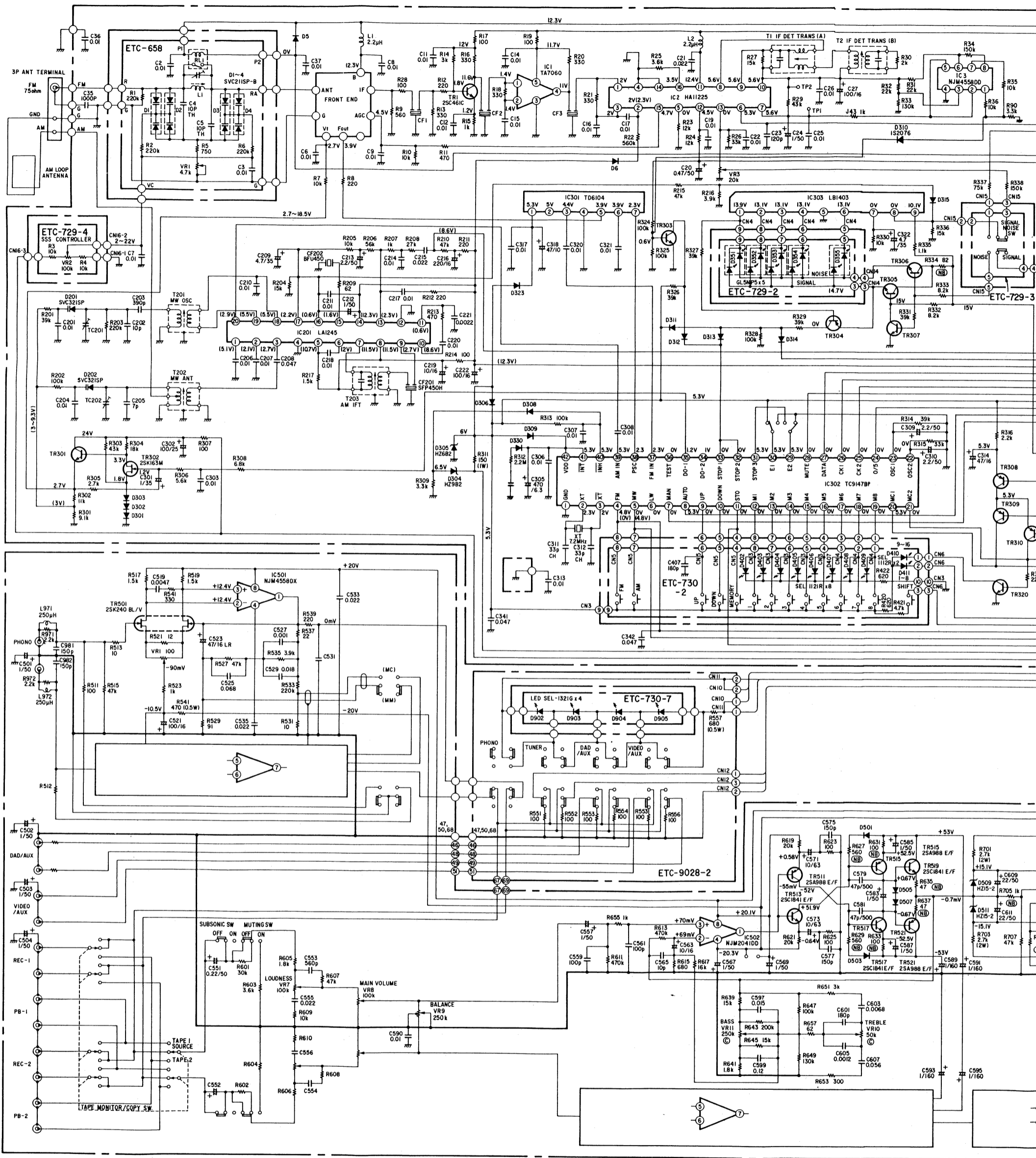

⚠ Means important safety item, which must be replaced, when necessary, by a part specified or meeting the specification by the manufacturer.

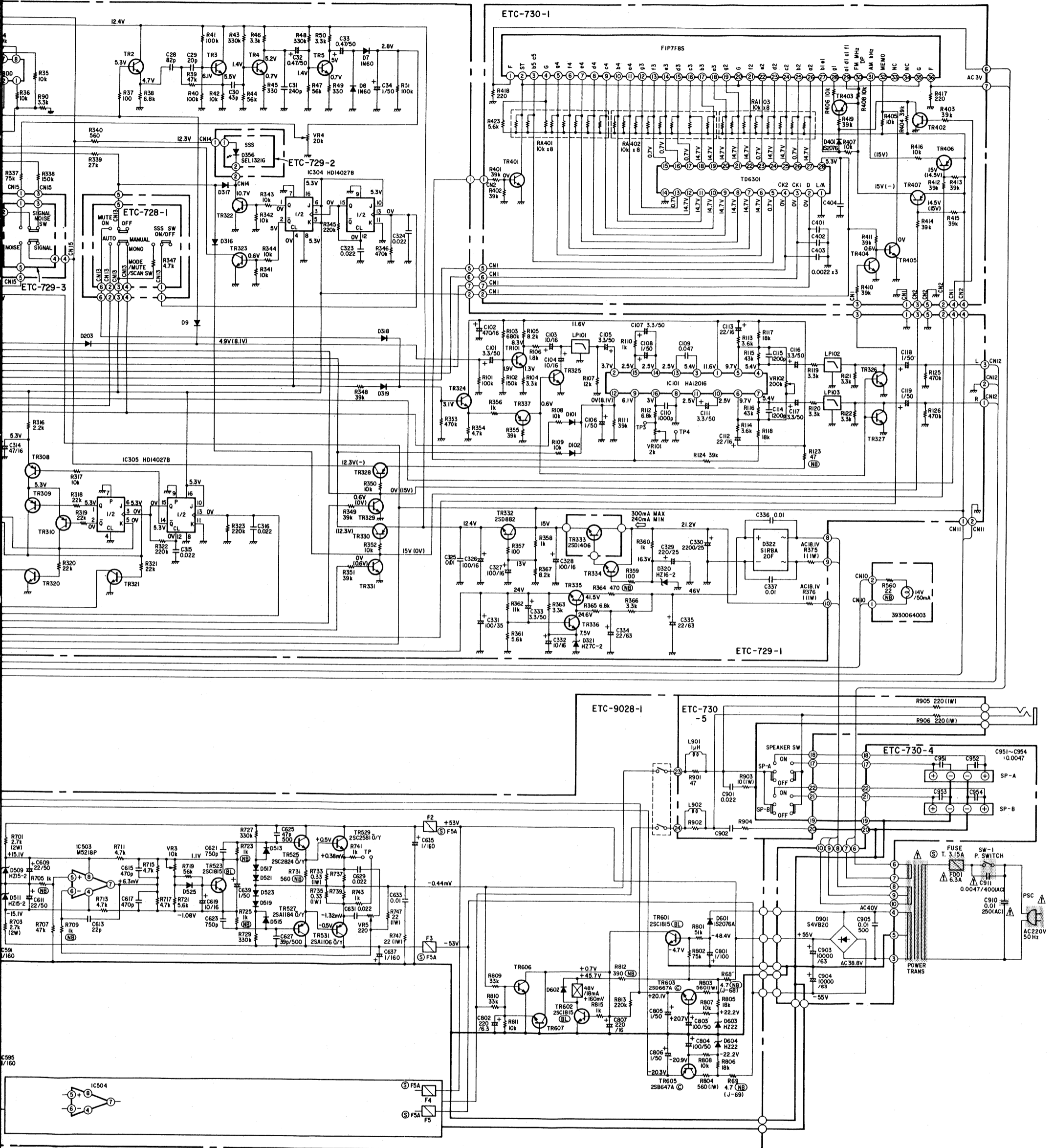

UNLESS OTHERWISE SPECIFIED, ALL SEMICONDUCTOR WITHOUT TYPE NUMBER ARE IS2076A/25C1685/25A564A
 VOLTAGE : MEASURED AT FM 87.5MHz NO SIGNAL INPUT
 () MEASURED AT AM 522kHz NO SIGNAL INPUT

NOTES

ALL RESISTANCE VALUES IN OHM K = 1,000 OHM M = 1,000,000 OHM
 ALL CAPACITANCE VALUES IN MICRO FARAD P = MICRO-MICRO FARAD
 EACH VOLTAGE AND CURRENT ARE MEASURED AT NO SIGNAL INPUT CONDITION.
 CIRCUIT AND PARTS ARE SUBJECT TO CHANGE WITHOUT PRIOR NOTICE.

EXPLODED VIEW OF CHASSIS AND CABINET

⚠ M when necessary by the manu

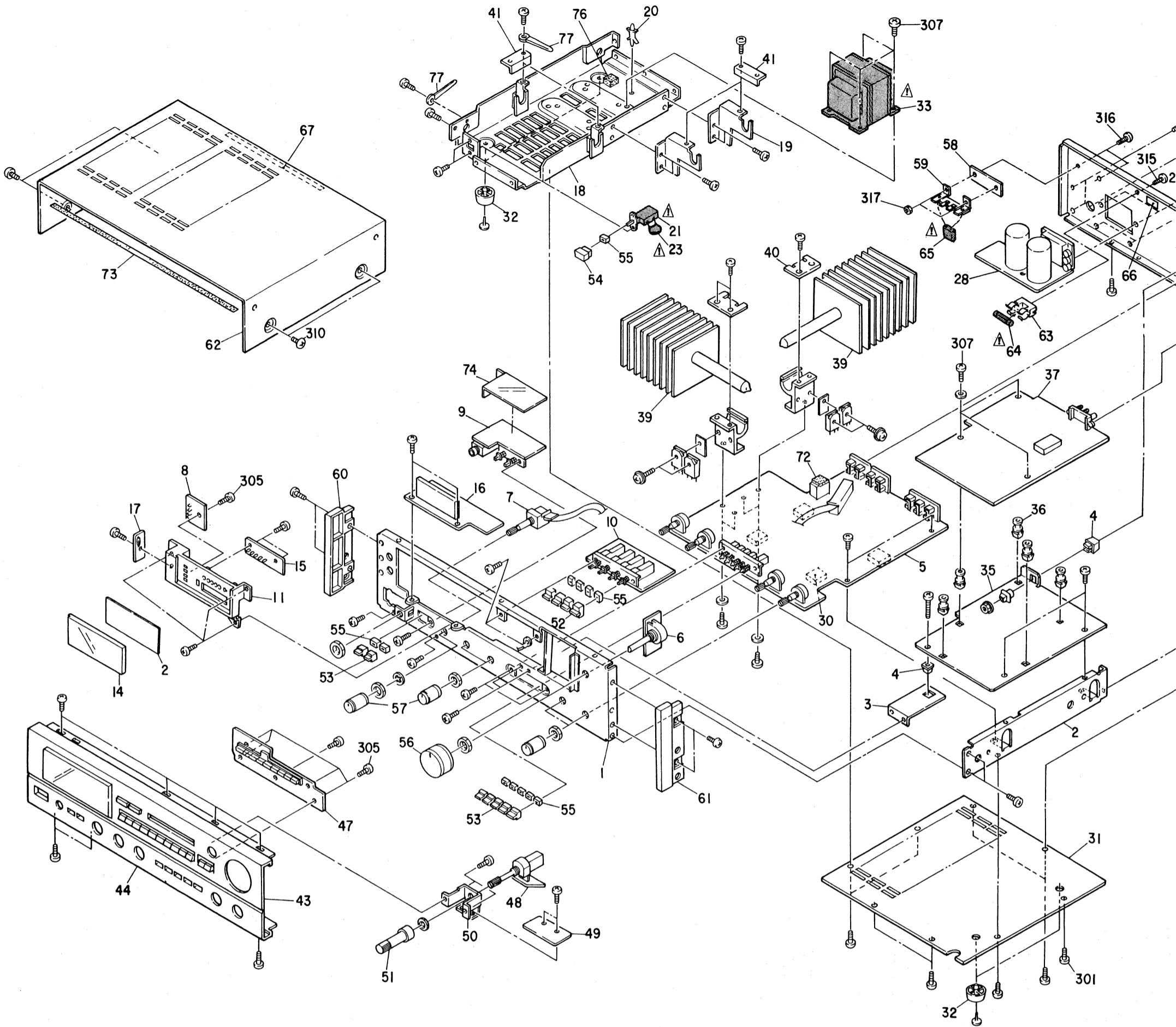

EXPLODED VIEW OF CHASSIS AND CABINET PARTS LIST (Gold Version)

Ref. No.	Part No.	Part Name & Descriptions	Ref. No.	Part No.	Part Name & Descriptions	Ref. No.	Part No.	Part Name & Descriptions	Ref. No.
1	4110430003	FRONT CHASSIS ASS'Y	26	2050071016	TERMINAL ASS'Y	*51	1130503104	KNOB ASS'Y (SSS)	76
2	4110422008	SIDE CHASSIS	27	4770018001	WASHER (P-87)	*52	1130604100	PUSH KNOB FOR FUNCTION	77
3	4121647102	BRACKET (F.C)	28	ETC073005	SP TERMINAL UNIT	*53	1130536029	PUSH KNOB FOR SP. MC. MUT	78
4	4150286000	P.C.B. HOLDER	29	1460494006	ANTENNA HOLDER	*54	1130515134	PUSH KNOB (A) FOR POWER	79
5	ETC9028-1	POWER PRE AMP UNIT	30	4610114023	CUSHION	55	1140056007	FLEXIBLE RING	80
6	ETC9028-3	MAIN VR UNIT	31	1050608008	BOTTOM COVER	*56	1120458104	KNOB ASS'Y FOR MAIN VR	81
7	2124505007	ROTARY REMOTE SW	32	1040111000	FOOT	*57	1120459103	KNOB ASS'Y FOR TONE, TAPE	82
8	ETC0730Q	CONTROL UNIT	33	2339528002	POWER TRANS	58	4150088004	INSULATING SHEET	83
9	ETC0730Q-4	SP SW & H.P UNIT	34	4450033005	WIRE CLAMP BAND 18	59	2050089008	7P W/TERMINAL	
10	ETC9028-2	FUNCTION SW UNIT	35	4140363108	SHIELD PLATE	*60	1460338230	ESC PLATE (L)	
11	1460695203	LED HOLDER	36	4150283003	P.C.B. HOLDER	*61	1460339239	ESC PLATE (R)	
12	1430370105	INDICATION SHEET	37	ETC0729H	TUNER UNIT	*62	1020178115	TOP COVER	
13	-	-	38	ETC0658J	TRAP UNIT	63	2020013101	FUSE HOLDER	
14	1430369006	INSIDE PLATE	39	4170232209	H.P RADIATOR	64	2061015074	FUSE (3.15A)	a.
15	ETC0729H-3	SIGNAL UNIT	40	4121646006	RADIATOR BRACKET	65	2568023006	METALIZED CAP. 0.01μF/250V AC(C-910)	b.
16	ETC0730Q7	F. LED UNIT	41	4121648004	BRACKET	66	5130654059	FUSE LABEL (T3.15A)	c.
17	ETC0730Q9	LAMP UNIT	42	ETC0729H-5	TR UNIT	67	1229006017	SPACER (220x5x0.5T)	d.
18	4110424200	TRANS CHASSIS ASS'Y	*43	1441240208	FRONT PANEL ASS'Y	68	-	-	e.
19	4121645007	H.P BRACKET (R)	*44	1130601103	PUSH KNOB ASS'Y	69	-	-	f.
20	4150228000	P.C.B. HOLDER	*45	1430374402	ESC BAR (L)	70	-	-	g.
21	2124409008	POWER SWITCH	*46	1430375304	ESC BAR (R)	71	-	-	h.
22	1059034000	BACK PANEL	47	ETC0730Q2	KEY LED UNIT	72	-	-	i.
23	2538003014	CERAMIC CAP 0.0047μF/400V AC(C-911)	48	ETC0729H-3	SSS SW UNIT	73	1229006004	SPACER (420x11x0.5T)	j.
24	2082002031	AC CORD WITH PLUG	49	ETC0729H-4	SSS VR UNIT	74	4150287009	ISOLATION SHEET	k.
25	4450020005	CORD BUSH	50	4121484103	VOLUME BRACKET	75	-	-	l.

▲ Means important safety item, which must be replaced, when necessary, by a part specified or meeting the specification by the manufacturer.

DENON

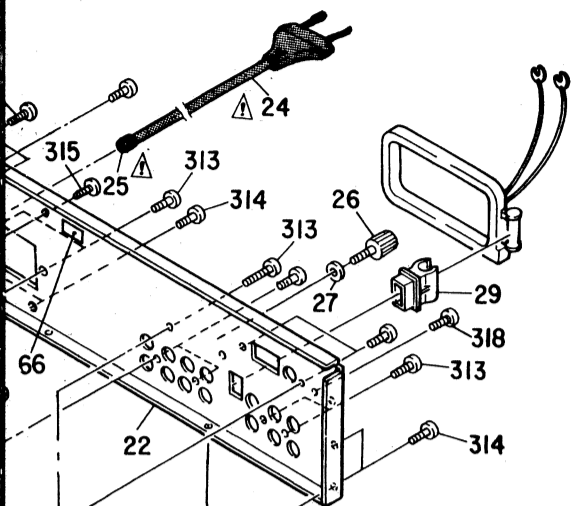

NIPPON COLUMBIA CO., LTD.

No. 14-14, 4-CHOME AKASAKA,
MINATO-KU, TOKYO 107 JAPAN
TEL: 03-584-8111
TLX: JAPANOLA J22591
CABLE: NIPPONCOLUMBIA TOKYO

Printed in Japan

Ref. No.	Part No.	Part Name & Descriptions
76	4610114007	CUSHION
77	4450048016	CORD HOLDER
78	1439003004	BLIND SHEET
79	1439003017	BLIND SHEET
80		
81		
82		
83		
PACKING & ACCESSORIES (not included EXPLODED VIEW)		
*a.	5019122000	CARTON CASE
b.	5030448103	CUSHION
c.	5058092049	LAMINATE ENVELOPE
d.		
e.	5050061007	ENVELOPE
f.	5119139003	INST. MANUAL
g.		
h.		
i.	2311060009	LOOP ANTENNA
j.	5290040008	FM ANT ADAPTOR
k.		
l.		

Ref. No.	Part No.	Part Name & Descriptions	
SCREWS, NUTS & WASHERS			
301	4737002005	TAPPING SCREW (S) 3x6	60
302	—	NUT M7 (SP)	7
303	—	TOOTH WASHER φ7	1
304	—	NUT M12 (SP)	1
305	4737500015	TAPPING SCREW (P) 3x8	9
306	—	—	—
307	4737004003	TAPPING SCREW (S) 4x8	7
308	—	—	—
309	—	—	—
*310	4734801005	TAPPING SCREW (TRUSS) 4x8	4
311	4751006016	WASHER φ5 (BLACK)	3
312	—	—	—
313	4737500044	TAPPING SCREW (P) 3x8 (BLACK)	10
314	4737002034	TAPPING SCREW (S) 3x6 (BLACK)	6
315	4734453039	TAPPING SCREW 4x6 (BLACK)	1
316	4700042005	PAN SCREW 3x8 (BLACK)	2
317	4756006008	NUT M3	2
318	4770064107	FIXING SCREW	1

BLACK VERSION PARTS LIST (Same as GOLD VERSION except the followings)

Ref. No.	Part No.	Part Name & Descriptions
43	1441240211	FRONT PANEL ASS'Y
44	1130601116	PUSH KNOB ASS'Y
45	1430374321	ESC BAR (L)
46	1430375317	ESC BAR (R)
51	1130503117	KNOB ASS'Y (SSS)
52	1130604126	PUSH KNOB FOR FUNCTION
53	1130536045	PUSH KNOB (B) FOR SP, MC, MUT
54	1139030102	PUSH KNOB (A) FOR POWER
56	1120458120	KNOB ASS'Y FOR MAIN VR
57	1120459129	KNOB ASS'Y FOR TONE, TAPE
60	1460338256	ESC PLATE (L)
61	1460339255	ESC PLATE (R)
62	1020178131	TOP COVER
310	4734454038	TAPPING SCREW (TRUSS) 4x8 (BLACK)
a.	5019122000	CARTON CASE