

SERVICE MANUAL MODEL DVD-2200

DVD AUDIO-VIDEO / SUPER AUDIO CD PLAYER

注 意

サービスをおこなう前に、このサービスマニュアルを必ずお読みください。本機は、火災、感電、けがなどに対する安全性を確保するために、さまざまな配慮をおこなっており、また法的には「電気用品安全法」にもとづき、所定の許可を得て製造されております。従ってサービスをおこなう際は、これらの安全性が維持されるよう、このサービスマニュアルに記載されている注意事項を必ずお守りください。

● For purposes of improvement, specifications and design are subject to change without notice.

● Please use this service manual with referring to the operating instructions without fail.

● Some illustrations using in this service manual are slightly different from the actual set.

● 本機の仕様は性能改良のため、予告なく変更することがあります。
● 補修用性能部品の保有期間は、製造打切後8年です。

● 修理の際は、必ず取扱説明書を参照の上、作業を行ってください。

● 本文中に使用しているイラストは、説明の都合上現物と多少異なる場合があります。

DENON, Ltd.

16 11, YUSHIMA 3 CHOME, BUNKYO KU, TOKYO 113 0034 JAPAN

SAFETY PRECAUTIONS

The following check should be performed for the continued protection of the customer and service technician.

LEAKAGE CURRENT CHECK

Before returning the unit to the customer, make sure you make either (1) a leakage current check or (2) a line to chassis resistance check. If the leakage current exceeds 0.5 milliamps, or if the resistance from chassis to either side of the power cord is less than 460 kohms, the unit is defective.

LASER RADIATION

Do not stare into beam or view directly with optical instruments, class 3A laser product.

注意

サービス、点検時には次のことにご注意願います。

●注意事項をお守りください！

サービスのとき特に注意を必要とする個所については、キャビネット、部品、シャーシなどにラベルや捺印で、注意事項を表示しています。これらの注意書きおよび取扱説明書などの注意事項を必ずお守りください。

●感電に注意！

- (1) このセットは、交流電圧が印加されていますので、通電時に内部金属部に触れると感電することがあります。従って通電サービス時には、絶縁トランスの使用や手袋の着用、部品交換には、電源プラグを抜くなどして、感電にご注意ください。
- (2) 内部には、高電圧の部分がありますので、通電時の取扱には、十分ご注意ください。

●指定部品の使用！

セットの部品は難燃性や耐電圧など安全上の特性を持ったものとなっています。従って交換部品は、使用されていたものと同じ特性の部品を使用してください。特に配線図、部品表に△印で指定されている安全上重要な部品は必ず指定のものをご使用ください。

●部品の取付けや配線の引きまわしは、元どおりに！安全上、テープやチューブなどの絶縁材料を使用したり、プリント基板から浮かして取付けた部品があります。また内部配線は引きまわしやクランプによって発熱部品や高圧部品に接近しないように配慮されていますので、これらは必ず元どおりにしてください。

●サービス後は安全点検を！

サービスのために取り外したねじ、部品、配線などが元どおりになっているか、またサービスした個所の周辺を劣化させてしまったところがないかなどを点検し、外部金属端子部と、電源プラグの刃の間の絶縁チェックをおこなうなど、安全性が確保されていることを確認してください。

(絶縁チェックの方法)

電源コンセントから電源プラグを抜き、アンテナや、プラグなどを外し、電源スイッチを入れます。500V絶縁抵抗計を用いて、電源プラグのそれぞれの端子と、外部露出金属部〔アンテナ端子、ヘッドホン端子、マイク端子、入力端子など〕との間で、絶縁抵抗値が1MΩ以上であること、この値以下のときは、セットの点検修理が必要です。

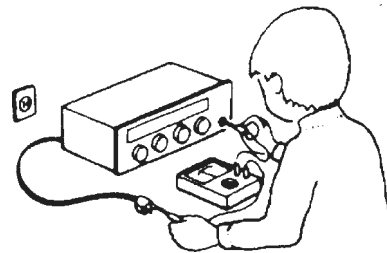

注意 安全上重要な部品について

本機に使用している多くの電気部品、および機構部品は安全上、特別な特性を持っています。この特性はほとんどの場合、外観では判別つきにくく、また、もとの部品より高い定格（定格電力、耐圧）を持ったものを使用しても安全性が維持されるとは、限りません。安全上の特性を持った部品は、このサービスマニュアルの配線図、部品表につぎのように表示していますので、必ず指定されている部品番号のものを使用願います。

(1)配線図… △マークで表示しています。

(2)部品表… △マークで表示しています。
指定された部品と異なるものを使用した場合には、感電、火災などの危険を生じる恐れがあります。

DISASSEMBLY

(Follow the procedure below in reverse order when reassembling.)

After removing the Top Cover, proceed as follows.

1. Loader Panel, Front Panel

1.1. When the Disc Tray can be ejected electrically

- (1) Plug the power cord to the wall outlet, switch on the power, and press the "OPEN/CLOSE" button to open the Disc Tray.
- (2) Detach the Loader Panel by lifting it in the arrow direction.
- (3) Press the "OPEN/CLOSE" button to close the Disc Tray, then unplug the power cord.
- (4) Remove 2 top screws and 4 bottom screws, then detach the Front Panel to the arrow direction..

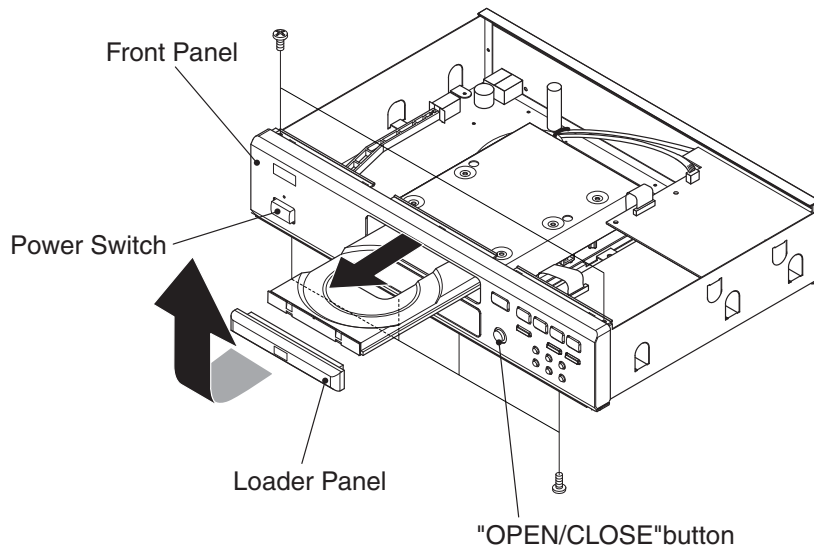

1.2. When the Disc Tray cannot be ejected electrically

- (1) Insert a straight ruler etc. into the left side of the Mechanism Unit and push the A-part (see Fig.) to open the Disc Tray manually.
- (2) Detach the Loader Panel by lifting it in the arrow direction.
- (3) Push the Disc Tray to close it manually.
- (4) Detach the Front Panel following the same steps described on the previous page 1.1.1. (4).

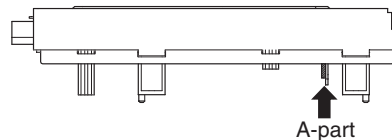
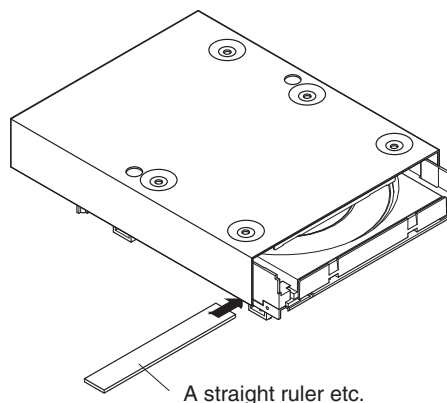

Fig. The left side view of the Mechanism.



各部のはずしかた

(組み立てるときは、逆の順序で行ってください。)

トップカバーをはずした状態で作業します。

1. フロントパネル、ローダーパネルのはずしかた

1.1. ディスクトレイが電動でオープンできる場合

- (1) 電源コードを電源コンセントに差し込み、電源スイッチを押し、「OPEN/CLOSE」ボタンを押し、ディスクトレイをオープンします。
- (2) ローダーパネルを矢印の方向に持ち上げ、はずします。
- (3) 「OPEN/CLOSE」ボタンを押し、ディスクトレイをクローズして、電源コンセントから電源コードを抜きます。
- (4) 上からねじ2本、下からねじ4本をはずし、フロントパネルを矢印の方向にはずします。

1.2. ディスクトレイが電動でオープンできない場合

- (1) メカユニットの左側から定規等を差し込み、A部を押し、ディスクトレイをオープンします。
- (2) ローダーパネルを矢印方向に持ち上げ、はずします。
- (3) ディスクトレイを押し、クローズします。
- (4) 前項 1.1.1. の (4) と同様に、フロントパネルをはずします。

2. DVD Mecha.

- (1) Remove 4 screws fixing the Mecha. Cover and detach the Mecha. Cover.
- (2) Remove 4 screws on the DVD Mecha. and 2 screws on the Main P.W.B., then take it off in the arrow direction.

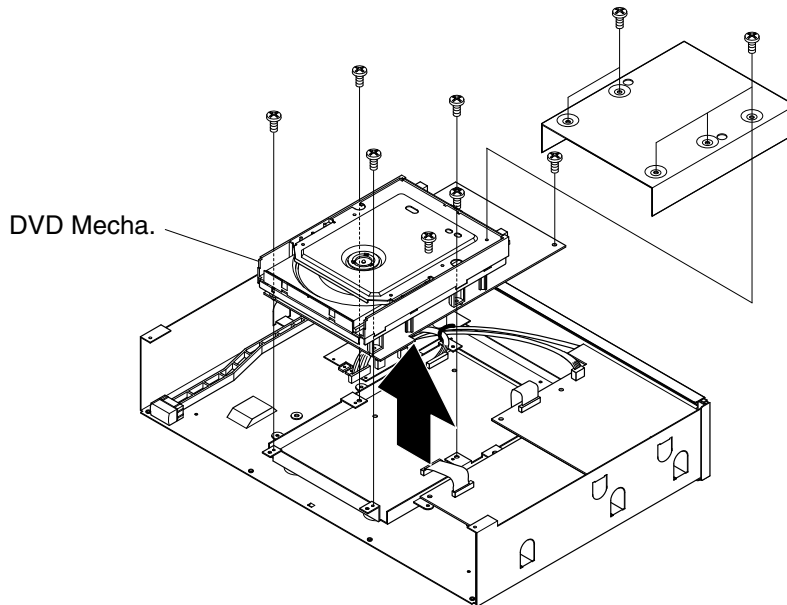

2. DVD メカのはずしかた

- (1) メカカバーの取付けねじを5本はずし、メカカバーを取りはずします。
- (2) DVD メカからねじ4本、メイン基板からねじ2本をはずし、矢印の方向へDVD メカをはずします。

3. Mecha.Unit

- (1) Remove 2 screws on the top of the Mecha. Unit, and detach the Guide Clamp Bracket with sliding in the arrow direction.
- (2) Solder the short-circuit on the Traverse Unit. (Refer to "Traverse Unit Disassembly" on page 5.
- (3) Disconnect the wires (CX151, CX241, CX031, CX051) connecting with the Main PWB.
- (4) Turn over the Mecha. Unit/Main PWB assembly, and remove 3 screws.

3. メカユニットのはずしかた

- (1) メカの上からねじ2本をはずし、ガイドクランプブラケットを矢印方向にずらしながらはずします。
- (2) ドライバーメカのショートサーキットを半田付けします。(トラバースユニットのはずしかた5ページ参照)
- (3) メイン基板と接続しているワイヤー (CX151, CX241, CX031, CX051) をはずします。
- (4) 一体のメカユニット/メイン基板を裏返し、ねじ2本をはずします。

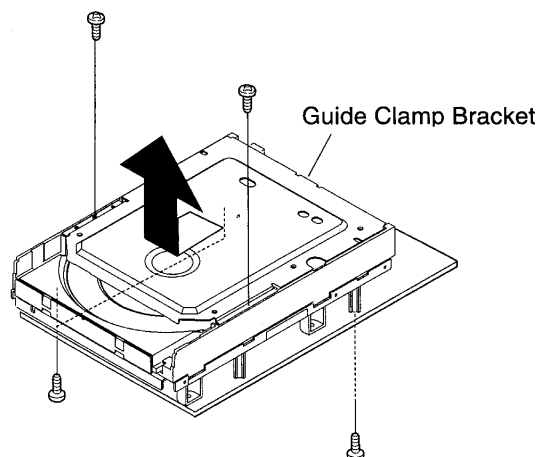

4. Traverse Unit Disassembly

Caution: The optical pickup can be damaged easily by static electricity charged on human body. Take necessary anti-static measures when repairing around the optical pickup.

4.1. Guide Clamp Bracket disassembly

- (1) Remove 2 screws.
- (2) Remove Guide Clamp Bracket to arrow direction.

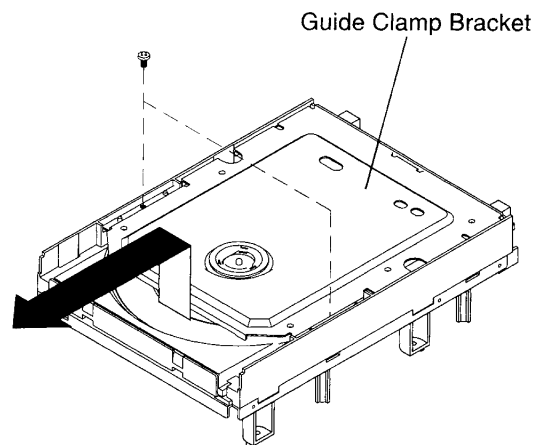

4. トラバースユニットのはずしかた

注意：光ピックアップは、人体に帯電した静電気等で静電破壊することがあります。光ピックアップ周辺を修理する際は、必要な静電対策を行ってください。

4.1. ガイドクランプブラケットのはずしかた

- (1) ねじ2本をはずします。
- (2) ガイドクランプブラケットを矢印方向にとりはずします。

4.2. Tray disassembly

- (1) Remove to arrow direction.
- (2) Solder the short-circuit (see in the frame).

4.2. トレイのはずし方

- (1) 矢印方向にとりはずします。
- (2) 半田付けショートを行います。(枠内図参照)

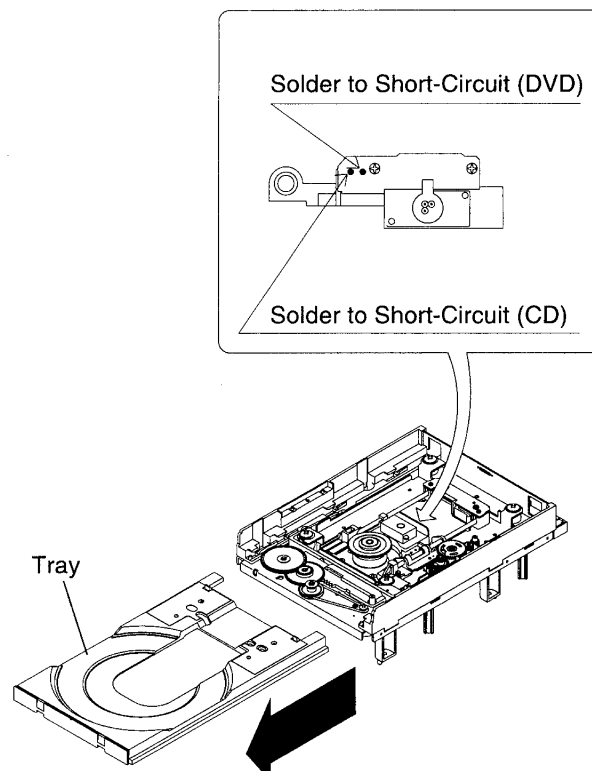

4.3. Traverse Unit disassembly

- (1) Remove 24P FFC (CX241), 15P FFC (CX151), 5P PH WIRE (CX051) and 3P PH WIRE (CX031) connecting with from the Main P.W.B.
- (2) Remove 4 screws fixing Damper.
- (3) Remove Traverse Unit to arrow direction.

4.3. トラバースユニットのはずしかた

- (1) メイン基板に接続している 24P FFC (CX241)、15P FFC (CX151)、5P PH ワイヤ (CX051)、3P PH ワイヤ (CX031) をはずします。
- (2) ダンパーを固定しているねじ 4 本をはずします。
- (3) トラバースユニットを矢印方向にとりはずします。

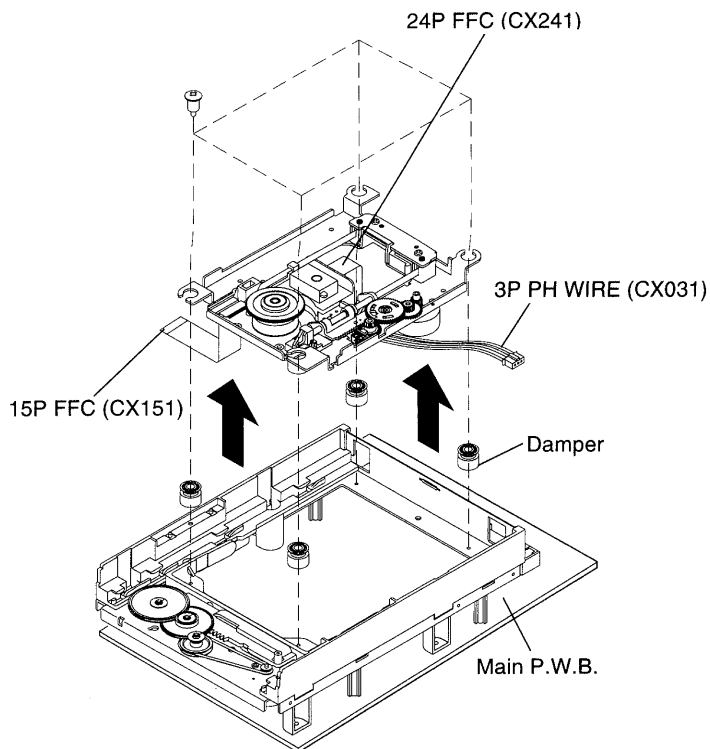

Note for disassembly Traverse Unit

- (1) When assembling, reverse the order of the above.
- (2) When inserting Tray, confirm boss on Slide Cam set to ditch of the Tray (Compare with below drawing).

トラバースユニット分解の注意

- (1) 組み立てるときは、上記の逆の順序で行ってください。
- (1) トレイ組込み時、スライドカムがボスがトレイの溝に合っているか確認してください。(下図参照)

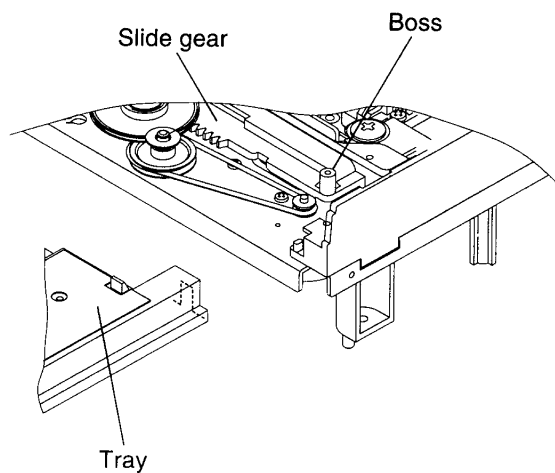

DIAGNOSTICS OF OPTICAL PICKUP AND REPLACING TRAVERSE UNIT 光ピックアップの故障診断とトラバースユニットの交換

Make failure diagnostics of the Optical Pickup as follows.

If the laser drive current becomes more than 1.5 times of the initial value, the Optical Pickup should be replaced.

The laser drive current is registered on the seal attached to the rear of the Mecha.Unit.

In case of replacing the Pickup, change the whole part of the Traverse Unit.

No mechanical adjustment is necessary after the replacement.

次の順序で故障診断を行ってください。

レーザー駆動電流が初期値の 1.5 倍以上になっている場合は光ピックアップ交換の目安となります。

レーザーの電流初期値は、メカの後部のシール上に記入されています。

ピックアップ交換の場合は、トラバースユニット単位での交換となります。メカの調整は不要です。

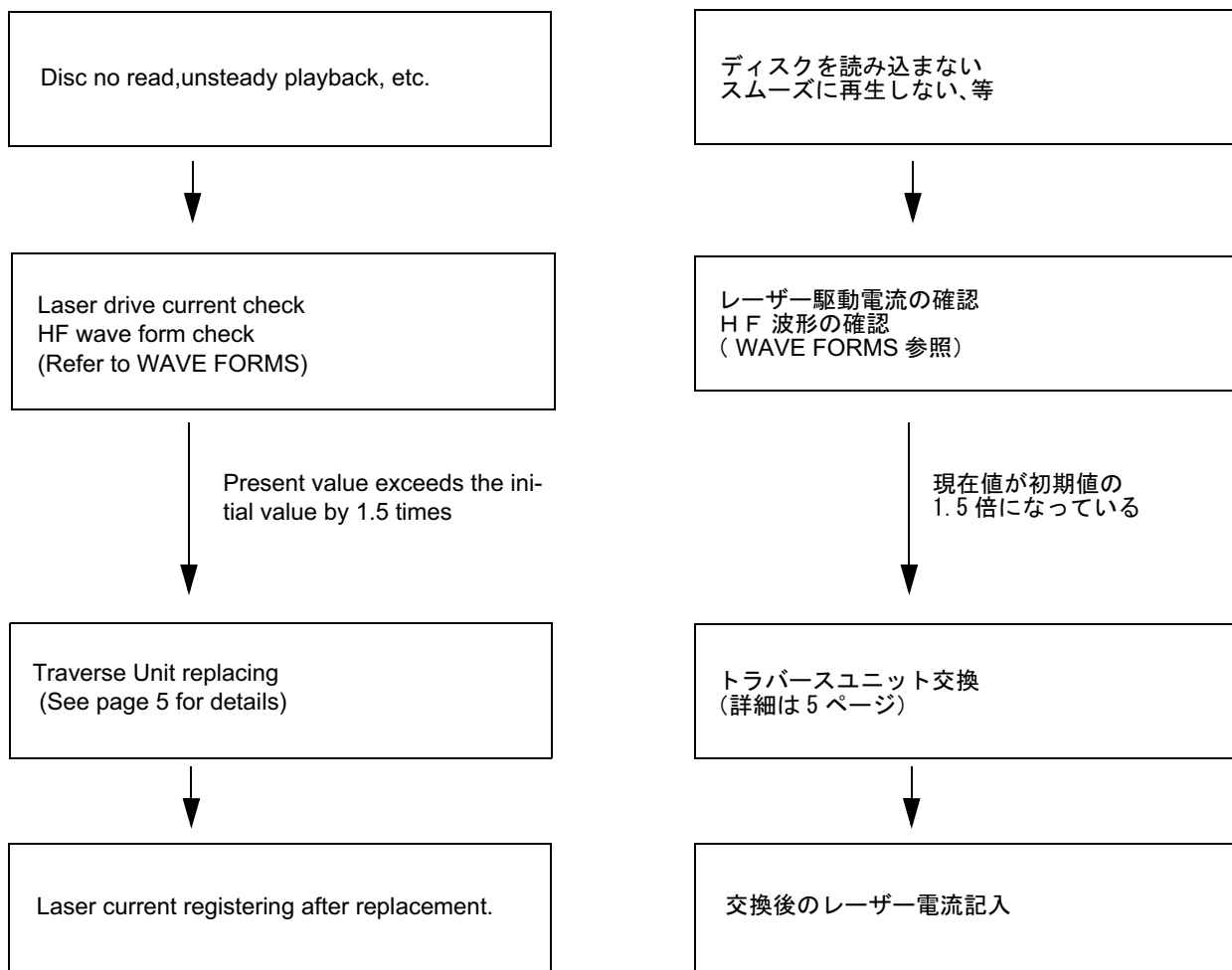
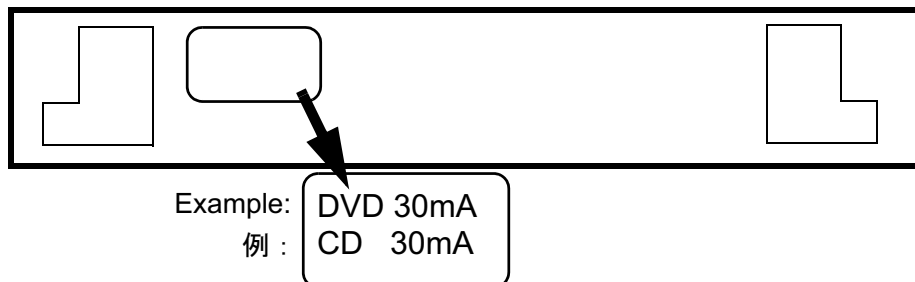

Step: Disc playback

Write the measured value on the seal attached to the Mecha. Unit

*As to the measuring method, refer to page 9.

手順 : ディスクを再生

その時の Iop 値をメカ後方のシールの上に重ねて貼る等で更新する。

*Iop の測定方法は、9 ページ参照。

1. Label Indication of DVD Mechanism.

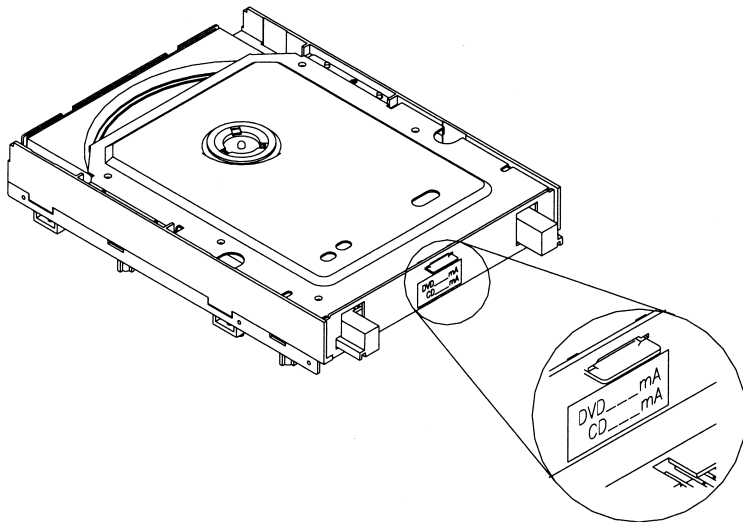

Laser current consumption value

ex) DVD * * * mA, CD * * * mA

レーザー駆動電流値

例) DVD * * * mA, CD * * * mA

2. Note for Handling the Laser Pick-Up

the protection for the damage of laser diode.

If you want to change the optical device unit from any other units, you must keep the following.

- (1) It should be done at the desk already took measures the static electricity in care of removing the OPU's (Optical device unit) connector cable.
- (2) Workers should be put on the "Earth Band".
- (3) It should be done to add the solder to the short land to prevent the broken Laser diode before removing the 24P FFC cable.
- (4) Don't touch OPU's connector parts carelessly.

3. Replacement of the Laser Pick-up (Traverse Unit)

Check the Iop(Laser drive current)

If the present Iop (current) value exceeds +50% of the initial value, replace the Traverse unit(Laser Pick-up) with a new one.

4. Iop Measurement Method

When measuring Laser drive current (Iop), playback the discs (CD,DVD) described below, measure Iop for CD Laser and DVD Laser by the test point (+5V-A2 --LD(CD), LD(DVD)) on the Main P.W.B.

Test Disc :DVD/DVDT-S01 or commercially available discs.
:CD/TCD-784 (manufactured by ALMEDIO INC)
or commercially available discs.

1. DVD メカのラベル表示

2. レーザーピックアップの取扱注意

レーザーダイオードの破壊防止。

光素子ユニットを交換するときは、以下を遵守してください。

- (1) 光素子ユニットの接続ケーブルをはずすときは、静電対策を行ったデスク上で作業してください。
- (2) 作業者は、リストストラップを使用してください。
- (3) レーザーダイオードの破壊防止のため、24P FFCケーブルをはずす前にランドを半田付けショートしてください。
- (4) 光素子ユニットのコネクタ部に触れないでください。

3. レーザーピックアップ（トラバースユニット）の交換

Iop（レーザー駆動電流）をチェックします。

現在の Iop 値が初期値の 50%を越えている場合、トラバースユニット（レーザーピックアップ）を交換してください。

4. Iop の測定方法

レーザー駆動電流を測定する場合、下記のディスク（CD, DVD）を再生します。

Main 基板上のテストポイント（+5V-A2 ~ LD(CD), LD(DVD)）にて、CD レーザーと DVD レーザーの Iop を測定してください。

テストディスク : DVD/DVDT-S01 または市販同等ディスク
: CD/TCD-784 (ALMEDIO 社製) または市販同等ディスク

4.1. DVD Laser current measurement

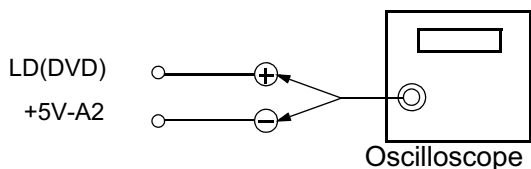

- (1) Connect the oscilloscope to +5V-A2 of test point for GND side and LD(DVD) of test point for signal side.
- (2) Playback the title 1 / chapter 1 of the DVD Test Disc.
- (3) Measure the voltage between +5V-A2 and LD(DVD), calculate I_{op} by the formula as shown below.

$$I_{op} = \frac{\text{Measurement Voltage Value}}{14 \text{ (Resistance value)}}$$

4.1. DVD レ ザ 電流測定

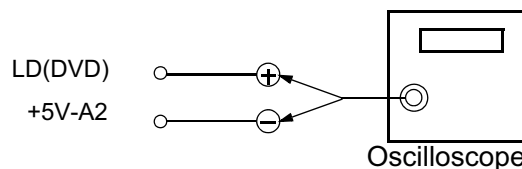

- (1) オシロスコープをテストポイント +5V-A2 (GND) と LD (DVD) (信号) へ接続します。
- (2) DVD テストディスクのタイトル1・チャプター1を再生します。
- (3) +5V-A2 と LD (DVD) 間の電圧を測定し、次式により I_{op} を算出します。

$$I_{op} = \frac{\text{測定電圧値}}{14 \text{ (抵抗値)}}$$

4.2. CD Laser current measurement

- (1) Connect the oscilloscope to +5V-A2 of test point for GND side and LD(CD) of test point for signal side.
- (2) Playback the track 1 of the CD Test Disc.
- (3) Measure the voltage between +5V-A2 and LD(CD), calculate I_{op} by the formula as shown below.

$$I_{op} = \frac{\text{Measurement Voltage Value}}{11.75 \text{ (Resistance value)}}$$

4.2. CD レ ザ 電流測定

- (1) オシロスコープをテストポイント +5V-A2 (GND) と LD (CD) (信号) へ接続します。
- (2) CD テストディスクのトラック1を再生します。
- (3) +5V-A2 と LD (CD) 間の電圧を測定し、次式より I_{op} を算出します。

$$I_{op} = \frac{\text{測定電圧値}}{11.75 \text{ (抵抗値)}}$$

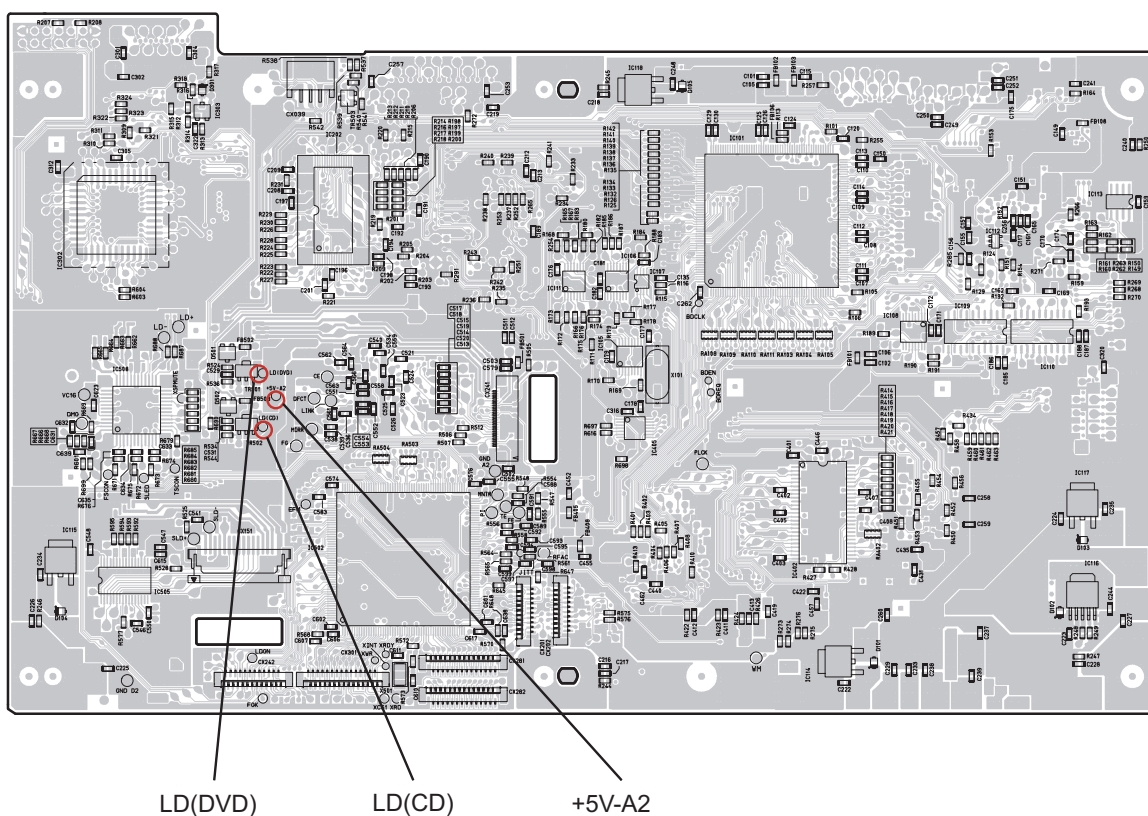

Main Unit foil side

SERVICE MODE

1. Aging Mode

(1) preparation

(a) Equipment used: Any one of DVD Karaoke Disc (containing more than 10 titles).

(b) Unit setting: No spec other than the following procedure (Aging mode).

At the tray open status, press the "POWER" button to turn on the power while pressing the "PLAY" and "OPEN/CLOSE" buttons for DVD operation simultaneously. ►■■ mark on the FL lights, and the unit is set to the heat run mode.

(2) procedure

(a) According to the above, set to the aging mode.

(b) Set a DVD Karaoke disc to the tray and press the "PLAY" button twice. ■■ mark on the FL blinks, and aging operation(after playback title-1 and title-10 of the disc, the tray open/close is made automatically, then playback the title-1 again) starts. This aging operation continues automatically until it is stopped or it stops caused by an error. In case of some error in DVD, the tray opens and the following error messages are displayed on the FL.

No	Error contents	FL display
1	Bad Disc	ERROR 02
2	Focus Error	ERROR 02
3	Read Error	ERROR 02
4	Tracking Error	ERROR 04
5	Tray Error	ERROR 05
6	Navigation Pack Read Error	ERROR 06

2. Initial Setting Mode

(1) Preparation

(a) Equipment used: None

(b) Unit setting: No spec other than the following procedure

(2) Procedure

(a) Initialize the DVD player when μ com, peripheral parts of μ com, or Main P.W.B. has been replaced in servicing.

(b) Carry out the following to restore factory setting mode. At the player stop condition, press 3 buttons for DVD operation("PLAY", "OPEN/CLOSE", and "▶▶▶ SKIP") until "INITIALIZE" appears and disappears in the FL.

("Initialized" appears and disappears on the TV screen.)

(c) All user setting will be lost and its factory setting will be restored when this initialization is made. Be sure to memorize your setting for restoring again after the initialization.

サービスモードについて

1. エージングモード

(1) 準備

(a) 使用機器: DVD カラオケディスク (10 タイトル以上の物)。

(b) 本体設定: 下記設定以外規定無。

(エージングモード)

トレイを開けた状態で DVD ユニットの「再生ボタン」+「開/閉ボタン」を同時に押しながら「電源ボタン」を押してセットの電源を入れると、FL 管の ►■■ マークが点灯し、ヒートランモードに設定される。

(2) 手順

(a) 上記手順でエージングモードに設定する。

(b) トレイに DVD カラオケディスクを入れ、「再生ボタン」を 2 回押して、FL 管の ■■ マークが点滅になると、「ディスクのタイトル 1 とタイトル 10 を再生した後、トレイを自動で開/閉し、再度タイトル 1 の再生を行う。」エージング動作になります。停止させるか、エラーにて停止するまでこの動作を自動で繰り返します。DVD 部にエラーが発生した場合は、FL 管に下表のエラーが表示されます。

No.	エラ 内容	FL 管表示
1	不良ディスク	ERROR 02
2	フォーカスエラー	ERROR 02
3	リードエラー	ERROR 02
4	トラッキングエラー	ERROR 04
5	トレイエラー	ERROR 05
6	ナビゲーションパックエラー	ERROR 06

2. 初期設定モード

(1) 準備

(a) 使用機器: 無

(b) 本体設定: 下記手順以外規定無。

(2) 手順

(a) サービスにて、マイコンやマイコン周辺部分やメイン基板を交換した場合は、DVD プレーヤーの初期化を行ってください。

(b) セットの初期化を下記の手順で行い、工場出荷モードに設定する。

セットが停止状態にて、DVD 操作部の「再生ボタン」+「開/閉ボタン」+「▶▶▶ (スキップ) ボタン」の 3 重押しを FL 管に "INITIALIZE" が表示され消えるまで押します。(TV 画面には "初期化しました" が表示され消えます。)

(c) 初期化を行うとお客様が設定した内容が工場出荷状態に戻りますので、あらかじめ設定内容を控えておき初期化後に再設定してください。

3. μ -Com Firm Check Mode

(1) Preparation

- (a) Equipment used: None
 (b) Unit setting: No spec other than the following procedure.

(2) Procedure

- (a) Press the "POWER" button to turn on the power while pressing the "PLAY" and "OPEN/CLOSE" buttons for DVD operation simultaneously.
- (b) FL all light mode.
 This mode is for detecting FL defects. Press "STILL/ PAUSE ■■" on the remote control unit once to light all FL segments.
- (c) DVD μ com and main unit μ com firm check mode. This mode is for displaying the status of each μ com employed.
- DVD μ com firm: Press the "MENU" button or ◀◀, ▶▶ button.
 - Each time the "MENU" button or ◀◀, ▶▶ button on the remote control unit is pressed, μ com firm is displayed one after another.

Ex.: [DRV_030307, B/E 6500, PANEL 6499]

	Set Serial No. (lower 5 digits)	Drive μ com	B/E μ com	Panel μ com
1	00001	Ver.030307 (Display) 030307	Ver.6500 (Display) 6500	Ver.6499 (Display) 6499
2				
3				
4				

3. マイコンファームチェックモード

(1) 準備

- (a) 使用機器：無
 (b) 本体設定：下記手順以外規定無。

(2) 手順

- (a) DVD 操作部の「再生ボタン」と「開/閉ボタン」を押しながらセットの「電源ボタン」を押し電源を入れます。
- (b) FL 管全点灯 / 全消灯モード。
 FL 管の故障判別用のモードで、リモコンの「スティル / ポーズ ■■ ボタン」を押すと FL 管が全点灯します。
- (c) DVD マイコン及び本体マイコンのファーム確認モード
 搭載されている各マイコンのファーム状態を表示します。
- DVD マイコンのファーム：リモコンの「メニューボタン」または ◀◀、▶▶ ボタンを押します。
 - リモコンのメニューボタンまたは ◀◀、▶▶ ボタンを押すたびにマイコンファームを次々と表示します。
 表示例：[DRV 030307、B/E 6500、Panel 6499]

	セットのシリアル番号 (下5桁)	ドライブマイコン	B/E マイコン	パネルマイコン
1	00001 ~	Ver. 030307 (表示)030307	Ver. 6500 (表示)6500	Ver. 6499 (表示)6499
2				
3				
4				

4. Setting up the test mode

(1) Setting up

- In order to set up the test mode, you press STOP button and REV button simultaneously in the heat-run mode. Fundamentally, you can set up the test mode at the stop state after disc loading. (Heat-run mode is set up by pressing PLAY button, holding OPEN/CLOSE button. If it becomes heat run mode, PLAY indicator and PAUSE indicator will light up.)

LOADING display



FL display (The display part of 13 digits)												
1	2	3	4	5	6	7	8	9	10	11	12	13
T												

(2) Mode Select

- There are two, servo adjustment value display mode and trace mode (error rate display), in the mode.
- (a) If the REV button or the FWD button is pushed in the test mode, it will become servo adjustment value display mode.

FL display (The display part of 13 digits)												
1	2	3	4	5	6	7	8	9	10	11	12	13
T	3											

- (b) If the REV button or the FWD button is pushed again, it will become the trace mode (error rate display).

FL display (The display part of 13 digits)												
1	2	3	4	5	6	7	8	9	10	11	12	13
T	7											

(3) Mode decision

- The mode will be decided if the PLAY button is pushed in the state where the mode is chosen.
- (a) In the case of servo adjustment value display mode, a focus offset adjustment value is displayed.

FL display (The display part of 13 digits)												
1	2	3	4	5	6	7	8	9	10	11	12	13
T	3	1	n	n	n	n	n	n	n	n	n	n

(n: adjustment value)

- (b) In the case of trace mode (error rate display), trace of the circumference in one layer is chosen.

FL display (The display part of 13 digits)												
1	2	3	4	5	6	7	8	9	10	11	12	13
T	7	1	F	F	F	F	F	F	F	F	F	F

(F: An address and an error rate display F at the time of undecided.)

(4) Change within the mode

- If the REV button or the FWD button is pushed in the state where the mode is decided, a change within the mode will be made.
- (a) In the case of servo adjustment value display mode (refer to table 1 servo adjustment value display mode details)

FL display (The display part of 13 digits)												
1	2	3	4	5	6	7	8	9	10	11	12	13
T	X	X	n	n	n	n	n	n	n	n	n	n

(XX: selection mode [31 ~ 62] n: adjustment value)

4. テストモード

(1) テストモードへの投入

- テストモードへの投入はヒートランモード時に STOP キーと REV キーを 2 重押しすることで行う。基本的にディスクローディング後の停止状態でテストモードに投入する。(ヒートランモードへの投入は OPEN/CLOSE キーと PLAY キーを 2 重押しすることで行う。ヒートランモードになるとPLAYインジケータとPAUSEインジケータが点灯する。)

LOADING 表示



FL 管の表示 (13 桁の表示部)												
1	2	3	4	5	6	7	8	9	10	11	12	13
T												

(2) モードの選択

- モードには、サーボ調整値表示モードとトレースモード (エラーレート表示) の 2 つがある。
- (a) テストモード投入後に REV キー又は FWD キーを押すと、サーボ調整値表示モードになる。

FL 管の表示 (13 桁の表示部)												
1	2	3	4	5	6	7	8	9	10	11	12	13
T	3											

- (b) 再度 REV キー又は FWD キーを押すとトレースモード (エラーレート表示) になる。

FL 管の表示 (13 桁の表示部)												
1	2	3	4	5	6	7	8	9	10	11	12	13
T	7											

(3) モードの確定

- モードを選択してある状態で PLAY キーを押すとモードを確定する。
- (a) サーボ調整値表示モードの場合は、フォーカスオフセット調整値を表示する。

FL 管の表示 (13 桁の表示部)												
1	2	3	4	5	6	7	8	9	10	11	12	13
T	3	1	n	n	n	n	n	n	n	n	n	n

(n: 調整値)

- (b) トレースモード (エラーレート表示) の場合は、1 層内周のトレースを選択する。

FL 管の表示 (13 桁の表示部)												
1	2	3	4	5	6	7	8	9	10	11	12	13
T	7	1	F	F	F	F	F	F	F	F	F	F

(F: アドレス及びエラーレートは未確定時、F を表示する。)

(4) モード内での変更

- モードを確定してある状態で REV キー又は FWD キーを押すとモード内での変更を行う。
- (a) サーボ調整値表示モードの場合 (表 1 サーボ調整値表示モード詳細 参照)

FL 管の表示 (13 桁の表示部)												
1	2	3	4	5	6	7	8	9	10	11	12	13
T	X	X	n	n	n	n	n	n	n	n	n	n

(X X: 選択モード [31 ~ 62]、n: 調整値)

- (b) In the case of trace mode (error rate display) (refer to table 2 trace mode details)

FL display (The display part of 13 digits)												
1	2	3	4	5	6	7	8	9	10	11	12	13
T	Y	Y	F	F	F	F	F	F	F	F	F	F

(YY: select mode [71 ~ 94], F: address and an error rate display F at the time of undecided)

(5) Execution of trace mode (error rate display) (refer to table 2 trace mode details)

- Trace will be performed if the PLAY button is pushed after choosing operation.

FL display (The display part of 13 digits)												
1	2	3	4	5	6	7	8	9	10	11	12	13
T	Y	Y	m	m	m	m	m	m	l	l	l	l

(YY:select mode[71 ~ 94],m:address[PBA][HEX],
l:error rate[COUNT/SEC][HEX])

(Note) Renewal of data is carried out for every CD:300 frame and DVD:85ECC block.

- The mode chosen when selection mode was changed into the trace execution and the PLAY button was pushed is performed from the beginning. When the PLAY button is pushed without changing selection mode, the mode under selection is performed from the beginning. (If the PLAY button is pushed, the address corresponding to the chosen mode will be searched again.)

(6) Other operation

- (a) If the STOP button is pushed into servo adjustment value display mode and trace mode (error rate display), it will return to the state at the time of a test mode injection.

FL display (The display part of 13 digits)												
1	2	3	4	5	6	7	8	9	10	11	12	13
T												

- (b) Push the OPEN/CLOSE button twice and carry out servo readjustment in OPEN operation ->CLOSE operation.

(It readjusts with test mode.)

OPEN display
↓
CLOSE display
↓
LOADING display
↓

FL display (The display part of 13 digits)												
1	2	3	4	5	6	7	8	9	10	11	12	13
T												

- (c) By pressing STOP button and REV button simultaneously in the test mode, it returns to heat-run mode.

- (b) トレースモード（エラーレート表示）の場合（表2 トレースモード詳細 参照）

FL 管の表示 (13桁の表示部)												
1	2	3	4	5	6	7	8	9	10	11	12	13
T	Y	Y	F	F	F	F	F	F	F	F	F	F

(YY: 選択モード [71 ~ 94]、F: アドレス及びエラーレートは未確定時、F を表示する。)

(5) トレースモード（エラーレート表示）の実行（表2 トレースモード詳細 参照）

- 動作を選択した後、PLAY キーを押すとトレースを実行する。

FL 管の表示 (13桁の表示部)												
1	2	3	4	5	6	7	8	9	10	11	12	13
T	Y	Y	m	m	m	m	m	m	l	l	l	l

(YY: 選択モード [71 ~ 94]、m: アドレス [PBA] [HEX]、
l: エラーレート [COUNT/SEC] [HEX])

(注) CD: 300フレーム、DVD: 85ECCブロック毎にデータ更新する。

- トレース実行中に選択モードを変更し、PLAY キーを押すと選択したモードを最初から実行する。選択モードを変更せずに PLAY キーを押した場合も、選択中のモードを最初から実行する。
(PLAY キーを押したら、選択しているモードに対応したアドレスを再度サーチする。)

(6) その他の動作

- (a) サーボ調整値表示モード、トレースモード（エラーレート表示）中に STOP キーを押すとテストモード投入時の状態に戻る。

FL 管の表示 (13桁の表示部)												
1	2	3	4	5	6	7	8	9	10	11	12	13
T												

- (b) OPEN/CLOSE キーを2回押して、OPEN 動作→CLOSE 動作で、サーボ再調整する。

(テストモードのまま再調整する。)

OPEN 表示
↓
CLOSE 表示
↓
LOADING 表示
↓

FL 管の表示 (13桁の表示部)												
1	2	3	4	5	6	7	8	9	10	11	12	13
T												

- (c) テストモード中に STOP キーと REV キーの2重押し（投入時と同じキー）で、ヒートランモードに戻る。

(7) Test mode detailed table

Table 1: servo adjustment value display mode details

XX	Contents	Contents supplement	Contents explanation
31	RFP FE Offset	layer 0	PI of CXD1881AR An offset value and FE An offset value is displayed. Pi offset is shown in higher rank 1Byte. FE offset is shown in low rank 1Byte.
32	RFP TE Bal Gain	layer 0	TE balance gain value of CXD1881AR is displayed.
33	RFP TE Output Gain	layer 0	TE output gain value of CXD1881AR is displayed.
34	RFP TE Offset	layer 0	TE offset value of CXD1881AR is displayed.
35	DSP TE Offset	layer 0	TE offset value inside CXD1885Q is displayed.
36	Fcs Bias	layer 0	The focus bias value inside CXD1885Q is displayed.
37	Fcs AGC	layer 0	The inside focus gain (setting 0x2000 to 1) value of CXD1885Q is displayed. Therefore, 0x1FF2 and in the case of 0x2012, it is as follows. $0x1FF2(8178) / 0x2000(8192) = 0.998291015625(\text{fold})$ $0x2012(8210) / 0x2000(8192) = 1.002197265625(\text{fold})$ Notes: The inside of () is a decimal system equivalent.
38	Trk AGC	layer 0	The inside tracking gain (setting 0x2000 to 1) value of CXD1885Q is displayed. Therefore, 0x1FF2 and in the case of 0x2012, it is as follows. $0x1FF2(8178) / 0x2000(8192) = 0.998291015625(\text{fold})$ $0x2012(8210) / 0x2000(8192) = 1.002197265625(\text{fold})$ Notes: The inside of () is a decimal system equivalent
39	Pi Offset	layer 0	It is the parameter calculated inside CXD1885Q. The value displayed on a set serves as the number of complement of 2 of 2Bytes(es) doubled 256. A voltage value is 6.25mV per bit.
40	FE Offset	layer 0	It is the parameter calculated inside CXD1885Q. The value displayed on a set serves as the number of complement of 2 of 2Bytes(es) doubled 256. A voltage value is 6.25mV per bit.
41	SE Offset	layer 0	It is the parameter calculated inside CXD1885Q. The value displayed on a set serves as the number of complement of 2 of 2Bytes(es) doubled 256. A voltage value is 6.25mV per bit.
42	RFP FE Offset	layer 1	PI of CXD1881AR An offset value and FE An offset value is displayed. Pi offset is shown in higher rank 1Byte. FE offset is shown in low rank 1Byte.
43	RFP TE Bal Gain	layer 1	TE balance gain value of CXD1881AR is displayed.
44	RFP TE Output Gain	layer 1	TE output gain value of CXD1881AR is displayed.
45	RFP TE Offset	layer 1	TE offset value of CXD1881AR is displayed.
46	DSP TE Offset	layer 1	It is the parameter calculated inside CXD1885Q. The value displayed on a set serves as the number of complement of 2 of 2Bytes(es) doubled 256. A voltage value is 6.25mV per bit.
47	Fcs Bias	layer 1	It is the parameter calculated inside CXD1885Q. The value displayed on a set serves as the number of complement of 2 of 2Bytes(es) doubled 256. A voltage value is 6.25mV per bit.
48	Fcs AGC	layer 1	The inside focus gain (setting 0x2000 to 1) value of CXD1885Q is displayed. Therefore, 0x1FF2 and in the case of 0x2012, it is as follows. $0x1FF2(8178) / 0x2000(8192) = 0.998291015625(\text{fold})$ $0x2012(8210) / 0x2000(8192) = 1.002197265625(\text{fold})$ Notes: The inside of () is a decimal system equivalent.

(7) テストモード詳細一覧表

表 1 サーボ調整値表示モード詳細

XX	内容	内容補足	内容説明
31	RFP FE Offset	レイヤ0	CXD1881ARのPI オフセット値とFE オフセット値を表示。上位1ByteにPi オフセットを示す。下位1ByteにFE オフセットを示す。
32	RFP TE Bal Gain	レイヤ0	CXD1881ARのTE バランスゲイン値を表示す。
33	RFP TE Output Gain	レイヤ0	CXD1881ARのTE 出力ゲイン値を表示す。
34	RFP TE Offset	レイヤ0	CXD1881ARのTE オフセット値を表示。
35	DSP TE Offset	レイヤ0	CXD1885Q内部のTE オフセット値を表示。
36	Fcs Bias	レイヤ0	CXD1885Q内部のフォーカスバイアス値を表示。
37	Fcs AGC	レイヤ0	CXD1885Q内部フォーカスゲイン(0x2000を1として)値を表示。0x1FF2や0x2012の場合、以下のようになる。 $0x1FF2(8178) / 0x2000(8192) = 0.998291015625(\text{倍})$ $0x2012(8210) / 0x2000(8192) = 1.002197265625(\text{倍})$ 注()内は10進換算値
38	Trk AGC	レイヤ0	CXD1885Q内部トラッキングゲイン(0x2000を1として)値を表示。0x1FF2や0x2012の場合、以下のようになる。 $0x1FF2(8178) / 0x2000(8192) = 0.998291015625(\text{倍})$ $0x2012(8210) / 0x2000(8192) = 1.002197265625(\text{倍})$ 注()内は10進換算値
39	Pi Offset	レイヤ0	CXD1885Q内部で計算されるパラメータ。セッットに表示される値は、256倍された2Bytesの2の補数となる。電圧値は1bitあたり6.25mV。
40	FE Offset	レイヤ0	CXD1885Q内部で計算されるパラメータ。セッットに表示される値は、256倍された2Bytesの2の補数となる。電圧値は1bitあたり6.25mV。
41	SE Offset	レイヤ0	CXD1885Q内部で計算されるパラメータ。セッットに表示される値は、256倍された2Bytesの2の補数となる。電圧値は1bitあたり6.25mV。
42	RFP FE Offset	レイヤ1	CXD1881ARのPI オフセット値とFE オフセット値を表示。上位1ByteにPi オフセットを示す。下位1ByteにFE オフセットを示す。
43	RFP TE Bal Gain	レイヤ1	CXD1881ARのTE バランスゲイン値を表示。
44	RFP TE Output Gain	レイヤ1	CXD1881ARのTE 出力ゲイン値を表示。
45	RFP TE Offset	レイヤ1	CXD1881ARのTE オフセット値を表示。
46	DSP TE Offset	レイヤ1	CXD1885Q内部で計算されるパラメータ。セッットに表示される値は、256倍された2Bytesの2の補数となる。電圧値は1bitあたり6.25mV。
47	Fcs Bias	レイヤ1	CXD1885Q内部で計算されるパラメータ。セッットに表示される値は、256倍された2Bytesの2の補数となる。電圧値は1bitあたり6.25mV。
48	Fcs AGC	レイヤ1	CXD1885Q内部フォーカスゲイン(0x2000を1として)値を表示。0x1FF2や0x2012の場合、以下のようになる。 $0x1FF2(8178) / 0x2000(8192) = 0.998291015625(\text{倍})$ $0x2012(8210) / 0x2000(8192) = 1.002197265625(\text{倍})$ 注()内は10進換算値

49	Trk AGC	layer 1	The inside tracking gain (setting 0x2000 to 1) value of CXD1885Q is displayed. Therefore, 0x1FF2 and in the case of 0x2012, it is as follows. $0x1FF2(8178) / 0x2000(8192) = 0.998291015625(\text{fold})$ $0x2012(8210) / 0x2000(8192) = 1.002197265625(\text{fold})$ Notes: The inside of () is a decimal system equivalent	49	Trk AGC	レイヤ1	CXD1885Q 内部トラッキングゲイン(0x2000を1として)値を表示。 0x1FF2や0x2012の場合、以下のようになる。 $0x1FF2(8178) / 0x2000(8192) = 0.998291015625(\text{倍})$ $0x2012(8210) / 0x2000(8192) = 1.002197265625(\text{倍})$ 注 () 内は10進換算値
50	Pi Offset	layer 1	It is the parameter calculated inside CXD1885Q. The value displayed on a set serves as the number of complement of 2 of 2Bytes(es) doubled 256. A voltage value is 6.25mV per bit.	50	Pi Offset	レイヤ1	CXD1885Q 内部で計算されるパラメータ。 セットに表示される値は、256倍された2Bytesの2の補数となる。 電圧値は1bitあたり6.25mV。
51	FE Offset	layer 1	It is the parameter calculated inside CXD1885Q. The value displayed on a set serves as the number of complement of 2 of 2Bytes(es) doubled 256. A voltage value is 6.25mV per bit.	51	FE Offset	レイヤ1	CXD1885Q 内部で計算されるパラメータ。 セットに表示される値は、256倍された2Bytesの2の補数となる。 電圧値は1bitあたり6.25mV。
52	SE Offset	layer 1	It is the parameter calculated inside CXD1885Q. The value displayed on a set serves as the number of complement of 2 of 2Bytes(es) doubled 256. A voltage value is 6.25mV per bit.	52	SE Offset	レイヤ1	CXD1885Q 内部で計算されるパラメータ。 セットに表示される値は、256倍された2Bytesの2の補数となる。 電圧値は1bitあたり6.25mV。
53	PO error detection number	Error rate	It is invalid at the time of CD operation.	53	P0 誤り検出数	エラーレート	CD時は無効。
54	PO uncorrectable error number	Error Rate	It is invalid at the time of CD operation.	54	P0 訂正不可数	エラーレート	CD時は無効。
55	PI error detection number	Error Rate	CD : C1 error detection number	55	PI 誤り検出数	エラーレート	CD時はC1誤り検出数。
56	PI uncorrectable error number	Error Rate	CD : C2 uncorrectable error number	56	PI 訂正不可数	エラーレート	CD時はC2訂正不可数。
57	Mirr Count	Disc discriminant	They are the contents at the time of disc distinction. Please refer to "Table 3 Disc distinction information" about the contents of a value.	57	Mirr Count	ディスク判別	ディスク判別時の内容。 値の内容は「表3ディスク判別情報」を参照。
58	Mirr Width	Disc discriminant	They are the contents at the time of disc distinction. Please refer to "Table 3 Disc distinction information" about the contents of a value.	58	Mirr Width	ディスク判別	ディスク判別時の内容。 値の内容は「表3ディスク判別情報」参照。
59	FZC Count	Disc discriminant	They are the contents at the time of disc distinction. Please refer to "Table 3 Disc distinction information" about the contents of a value.	59	FZC Count	ディスク判別	ディスク判別時の内容。 値の内容は「表3ディスク判別情報」参照。
60	Pi Level	Disc discriminant	They are the contents at the time of disc distinction. Please refer to "Table 3 Disc distinction information" about the contents of a value.	60	Pi Level	ディスク判別	ディスク判別時の内容。 値の内容は「表3ディスク判別情報」参照。
61	Disc Type	Disc Type	They are the contents at the time of disc type. Please refer to "Table 4 Disc classification information" about the contents of a value.	61	Disc Type	ディスク種別	ディスク種別の内容。 値の内容は「表4ディスク種別情報」参照。
62	PO error detection number and address	Error rate	PO error detection number is invalid at the time of CD operation.	62	P0 誤り検出数とアドレス	エラーレート	CD時はP0誤り検出数は無効。

Table 2: trace mode details

YY	Contents	Contents supplement
71	A display of PO error detection number of the inner circumference of 1-layer and an address.	It is invalid at the time of CD operation.
72	A display of PO uncorrectable number of the inner circumference of 1-layer and an address.	It is invalid at the time of CD operation.
73	A display of PI error detection number of the inner circumference of 1-layer and an address.	CD : C1 error detection number
74	A display of PI uncorrectable number of the inner circumference of 1-layer and an address.	CD : C2 uncorrectable error number
75	A display of PO error detection number of the central circumference of 1-layer and an address.	It is invalid at the time of CD operation.
76	A display of PO uncorrectable number of the central circumference of 1-layer and an address.	It is invalid at the time of CD operation.
77	A display of PI error detection number of the central circumference of 1-layer and an address.	CD : C1 error detection number
78	A display of PI uncorrectable number of the central circumference of 1-layer and an address.	CD : C2 uncorrectable error number
79	A display of PO error detection number of the outer circumference of 1-layer and an address.	It is invalid at the time of CD operation.
80	A display of PO uncorrectable number of the outer circumference of 1-layer and an address.	It is invalid at the time of CD operation.
81	A display of PI error detection number of the outer circumference of 1-layer and an address.	CD : C1 error detection number
82	A display of PI uncorrectable number of the outer circumference of 1-layer and an address.	CD : C2 uncorrectable error number
83	A display of PO error detection number of the inner circumference of 2-layer and an address.	In the case of 1-layer disc, it is invalid.
84	A display of PO uncorrectable number of the inner circumference of 2-layer and an address.	In the case of 1-layer disc, it is invalid.
85	A display of PI error detection number of the inner circumference of 2-layer and an address.	In the case of 1-layer disc, it is invalid.
86	A display of PI uncorrectable number of the inner circumference of 2-layer and an address.	In the case of 1-layer disc, it is invalid.
87	A display of PO error detection number of the central circumference of 2-layer and an address.	In the case of 1-layer disc, it is invalid.
88	A display of PO uncorrectable number of the central circumference of 2-layer and an address.	In the case of 1-layer disc, it is invalid.
89	A display of PI error detection number of the central circumference of 2-layer and an address.	In the case of 1-layer disc, it is invalid.
90	A display of PI uncorrectable number of the central circumference of 2-layer and an address.	In the case of 1-layer disc, it is invalid.
91	A display of PO error detection number of the outer circumference of 2-layer and an address.	In the case of 1-layer disc, it is invalid.
92	A display of PO uncorrectable number of the outer circumference of 2-layer and an address.	In the case of 1-layer disc, it is invalid.
93	A display of PI error detection number of the outer circumference of 2-layer and an address.	In the case of 1-layer disc, it is invalid.
94	A display of PI uncorrectable number of the outer circumference of 2-layer and an address.	In the case of 1-layer disc, it is invalid.

表 2 トレースモード詳細

YY	内容	補足説明
71	1層内周の P0 誤り検出数とアドレスの表示	CD 時は無効。
72	1層内周の P0 訂正不可数とアドレスの表示	CD 時は無効。
73	1層内周の PI 誤り検出数とアドレスの表示	CD 時は C1 誤り検出数。
74	1層内周の PI 訂正不可数とアドレスの表示	CD 時は C2 訂正不可数。
75	1層中周の P0 誤り検出数とアドレスの表示	CD 時は無効。
76	1層中周の P0 訂正不可数とアドレスの表示	CD 時は無効。
77	1層中周の PI 誤り検出数とアドレスの表示	CD 時は C1 誤り検出数。
78	1層中周の PI 訂正不可数とアドレスの表示	CD 時は C2 訂正不可数。
79	1層外周の P0 誤り検出数とアドレスの表示	CD 時は無効。
80	1層外周の P0 訂正不可数とアドレスの表示	CD 時は無効。
81	1層外周の PI 誤り検出数とアドレスの表示	CD 時は C1 誤り検出数。
82	1層外周の PI 訂正不可数とアドレスの表示	CD 時は C2 訂正不可数。
83	2層内周の P0 誤り検出数とアドレスの表示	1層ディスクの場合、無効。
84	2層内周の P0 訂正不可数とアドレスの表示	1層ディスクの場合、無効。
85	2層内周の PI 誤り検出数とアドレスの表示	1層ディスクの場合、無効。
86	2層内周の PI 訂正不可数とアドレスの表示	1層ディスクの場合、無効。
87	2層中周の P0 誤り検出数とアドレスの表示	1層ディスクの場合、無効。
88	2層中周の P0 訂正不可数とアドレスの表示	1層ディスクの場合、無効。
89	2層中周の PI 誤り検出数とアドレスの表示	1層ディスクの場合、無効。
90	2層中周の PI 訂正不可数とアドレスの表示	1層ディスクの場合、無効。
91	2層外周の P0 誤り検出数とアドレスの表示	1層ディスクの場合、無効。
92	2層外周の P0 訂正不可数とアドレスの表示	1層ディスクの場合、無効。
93	2層外周の PI 誤り検出数とアドレスの表示	1層ディスクの場合、無効。
94	2層外周の PI 訂正不可数とアドレスの表示	1層ディスクの場合、無効。

Table 3: Disc distinction information

	Mirr Count	Mirr Width	FZC Count	PI Level
No Disc	Except 2 and 3	-	-	-
CD High reflection	2	More than 0x8ED	-	More than 0x99
CD Low reflection	2	More than 0x8ED	-	Less than 0x98
DVD High reflection	2	Less than 0x8E9	1	More than 0x81
DVD Low reflection	2	Less than 0x8E9	1	Less than 0x80
DVD 2-layer	2	Less than 0x8E9	2	-
SACD Hybrid	3	-	-	-

PI level Formula : PI level (V) = Measured value x 1.6 ÷ 256
 "-": Invalid

表3 ディスク判別情報

	Mirr Count	Mirr Width	FZC Count	PI Level
No Disc	2と3以外	-	-	-
CD 高反射	2	0x8ED 以上	-	0x99 以上
CD 低反射	2	0x8ED 以上	-	0x98 以下
DVD 高反射	2	0x8E9 以下	1	0x81 以上
DVD 低反射	2	0x8E9 以下	1	0x80 以下
DVD 2層	2	0x8E9 以下	2	-
SACD Hybrid	3	-	-	-

PI level 計算式 : PI level (V) = 測定値 × 1.6 ÷ 256
 “-” は無効

Table 4: Disc classification information

Disc Type	Media
0x00	No Disc
0x01	Unknown Disc
0x04	DVD Single Low reflection
0x05	DVD Dual Parallel Low reflection
0x06	DVD Dual Opposite Low reflection
0x08	CDDA Low reflection
0x0A	VCD Low reflection
0x44	DVD Single High reflection
0x48	CDDA High reflection
0x4A	VCD High reflection
0x8F	SACD Hybrid Disc

表4 ディスク種別情報

Disc Type	Media
0x00	No Disc
0x01	Unknown Disc
0x04	DVD Single 低反射
0x05	DVD Dual Parallel 低反射
0x06	DVD Dual Opposite 低反射
0x08	CDDA 低反射
0x0A	VCD 低反射
0x44	DVD Single 高反射
0x48	CDDA 高反射
0x4A	VCD 高反射
0x8F	SACD Hybrid Disc

TROUBLE SHOOTING

1. GU-3570 MAIN PWB

1.1. FL TUBE doesn't light

(1) Check the Set-up process of Panel μ -COM

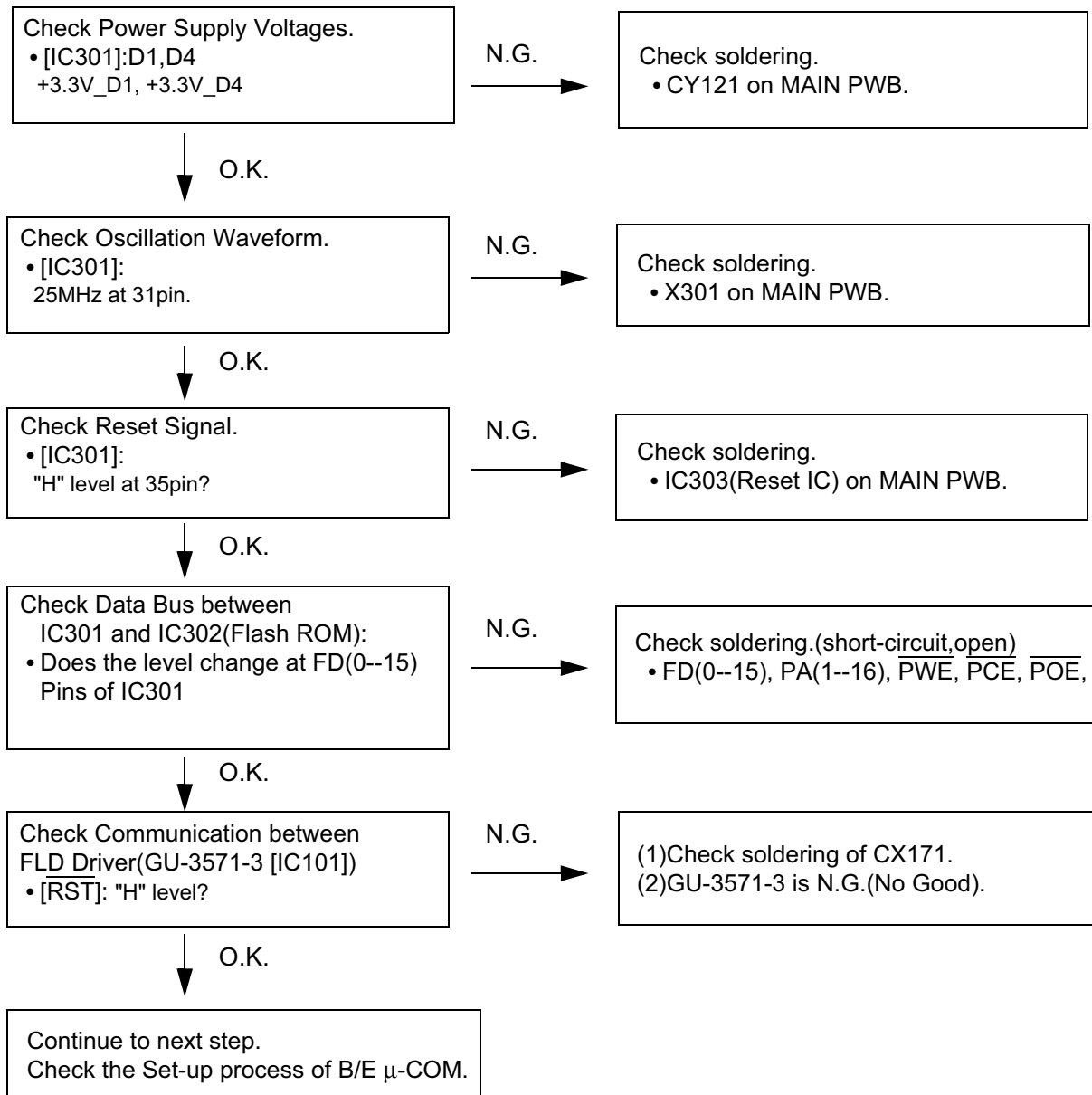

(2) Check the Set-up process of B/E μ -COM.

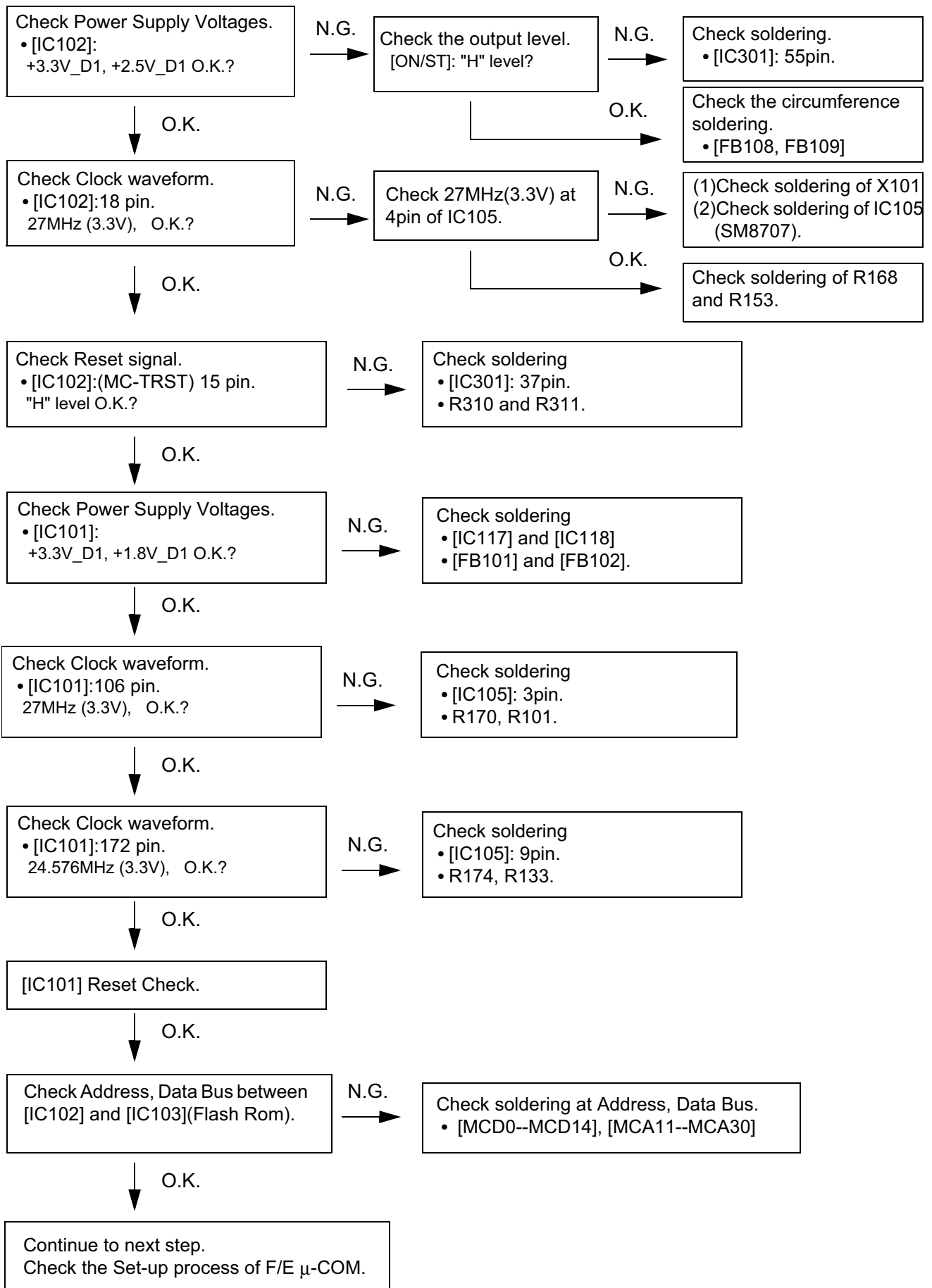

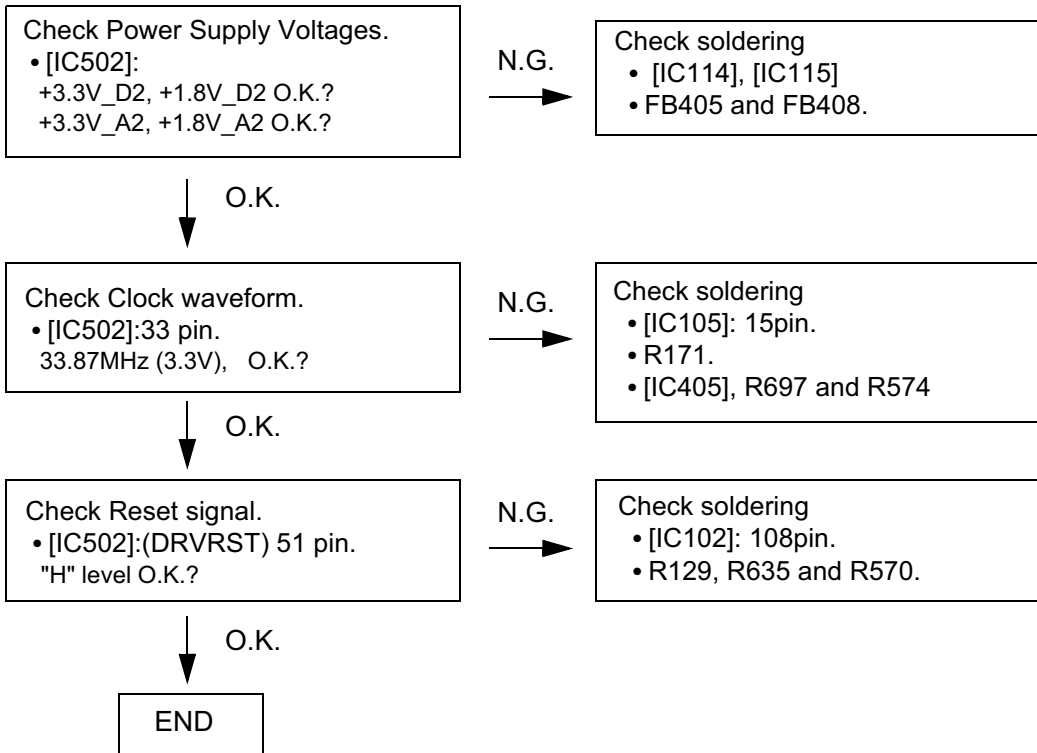
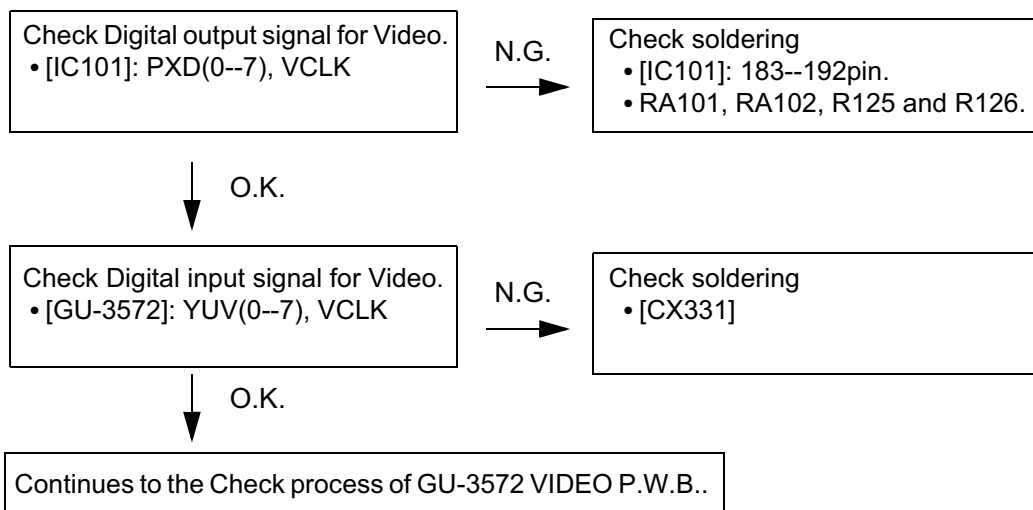
(3) Check the Set-up process of F/E μ -COM.**1.2. Image is not displayed. (Blue-back, DENON wallpaper)**

1.3. Does not Read Disc

[No PLAY], [00 00] displayed etc.

(1) Disc does not Rotate.

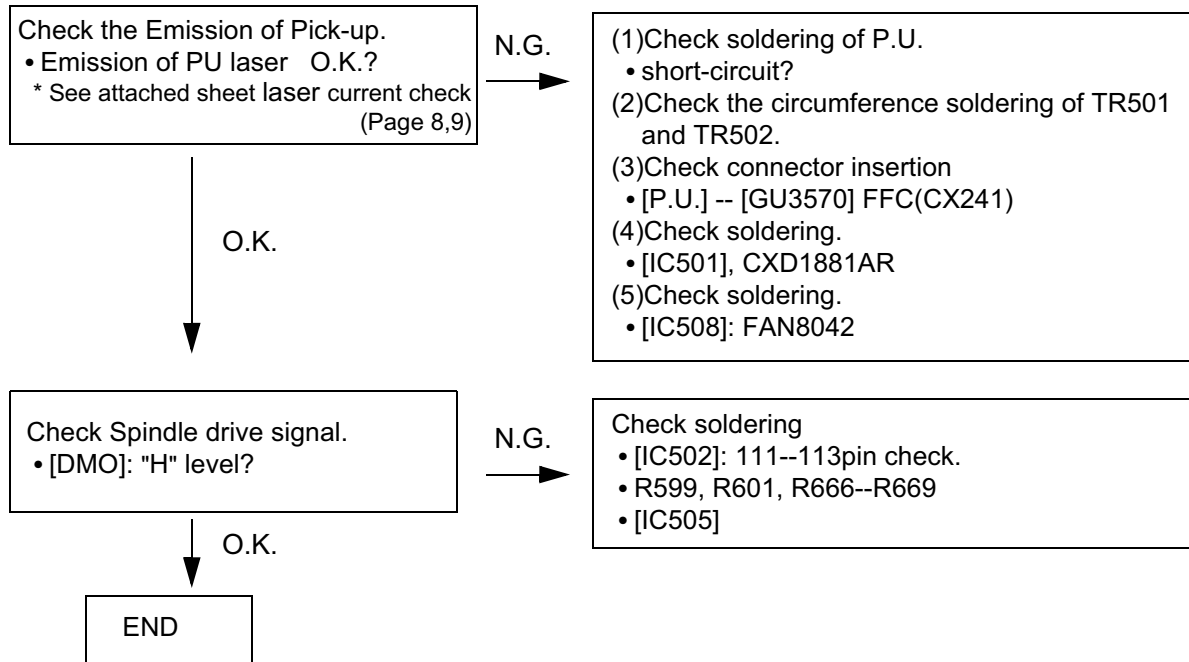

(2) CD check process

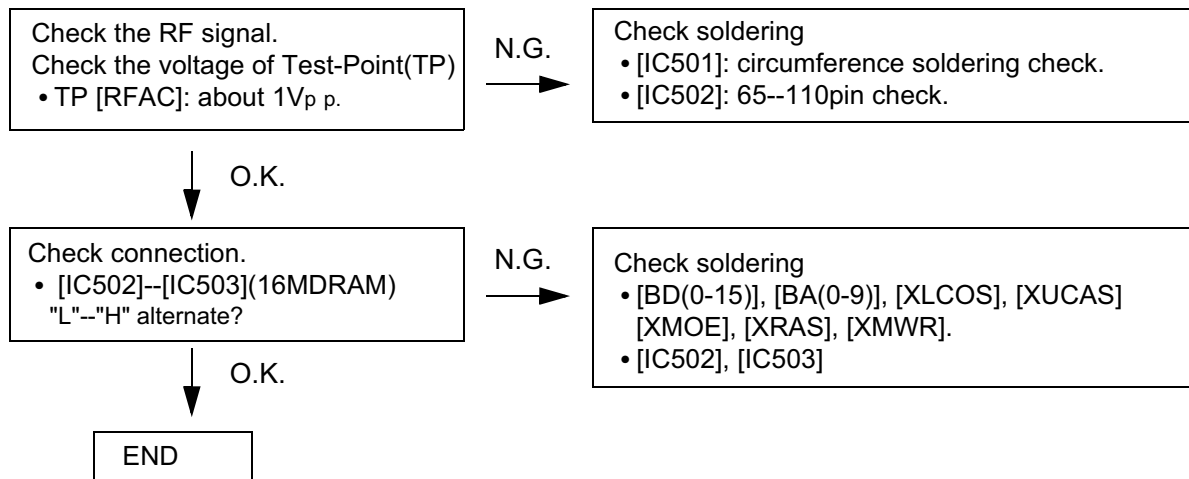

(3) DVD check process

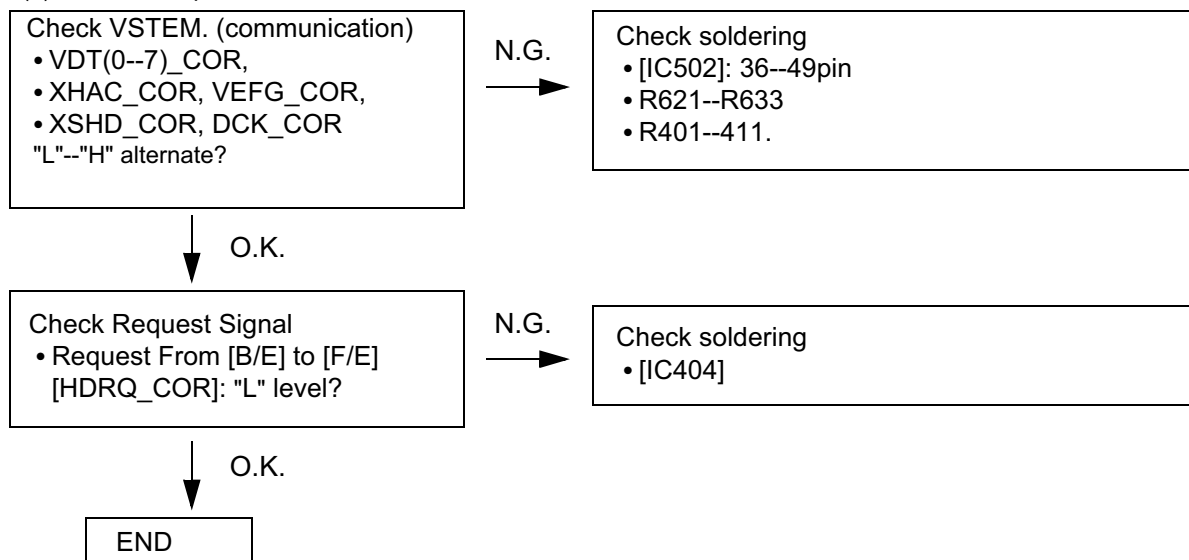

(4) SACD check process

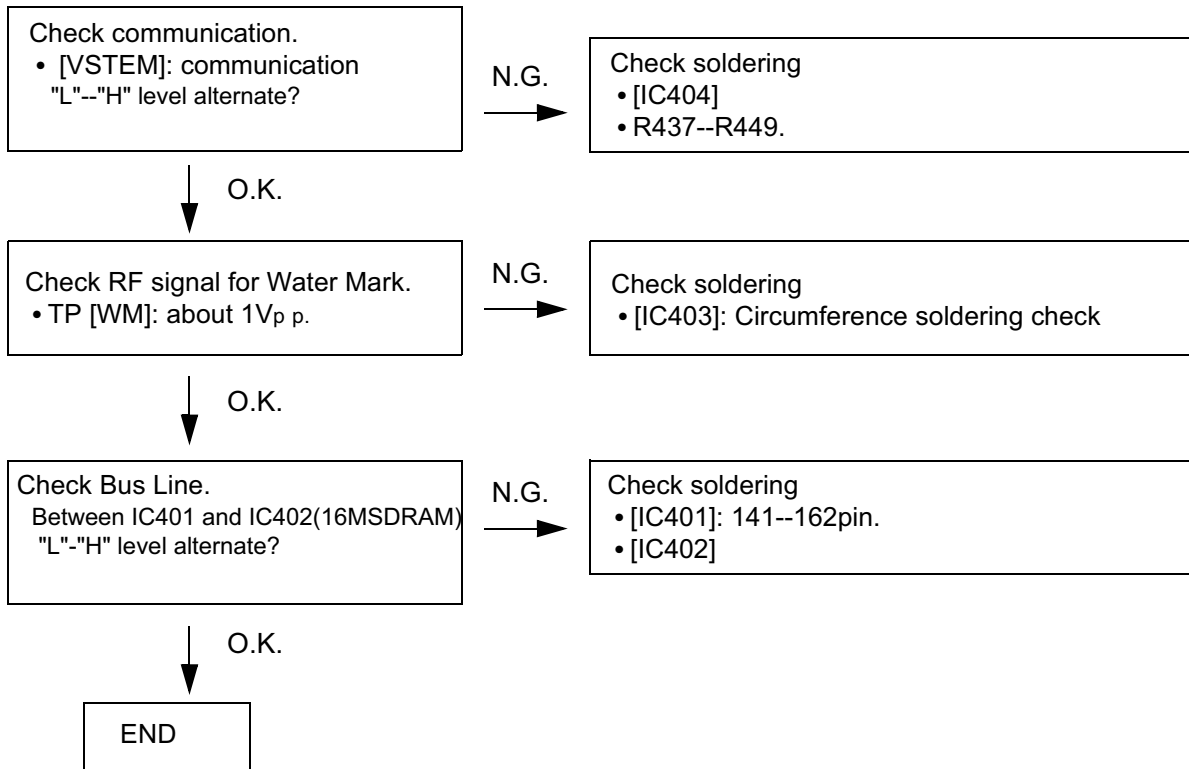

1.4. No sound, Noise generated

(1) CD

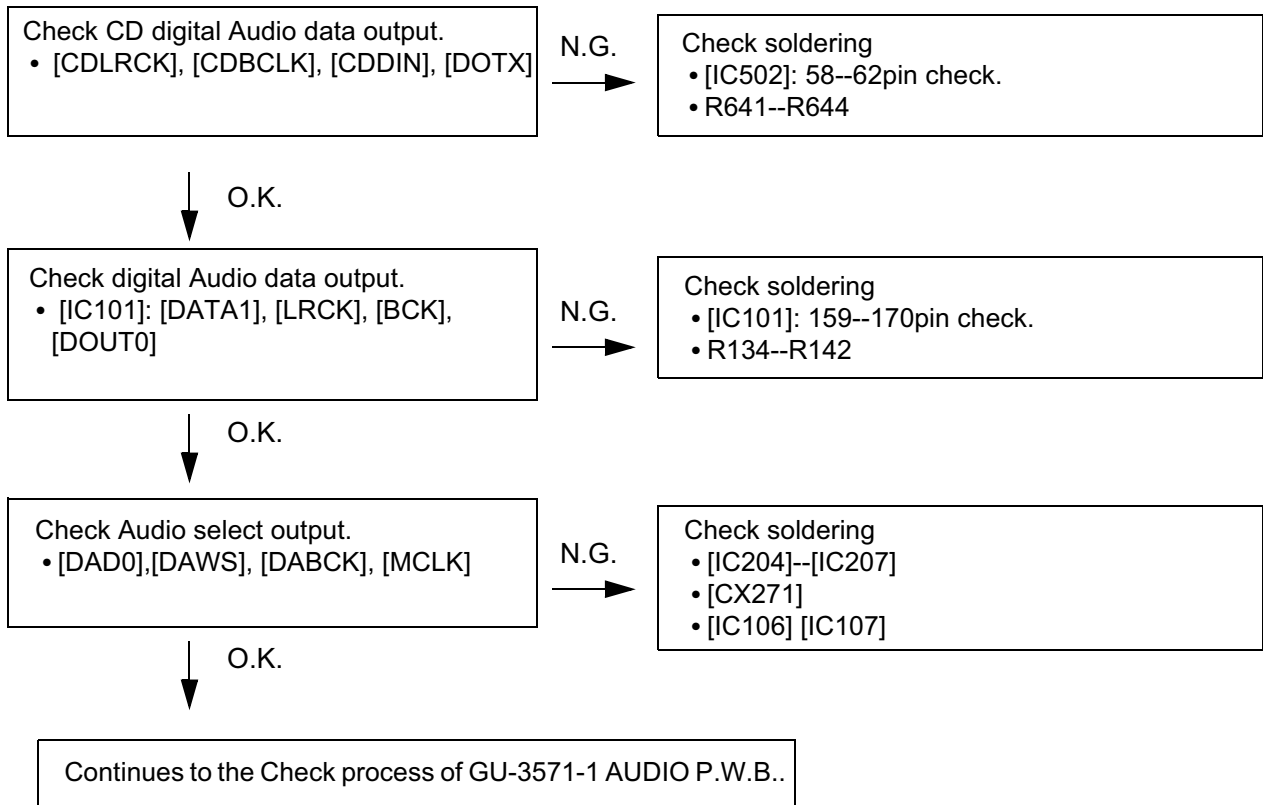

(2) SACD

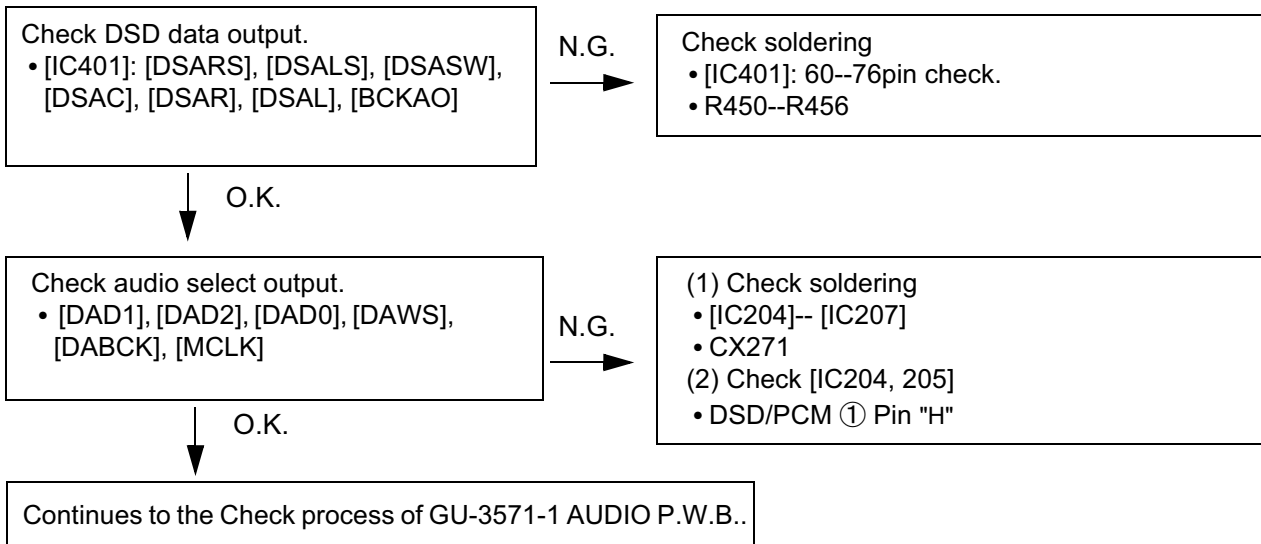

(3) DVD-VIDEO / AUDIO

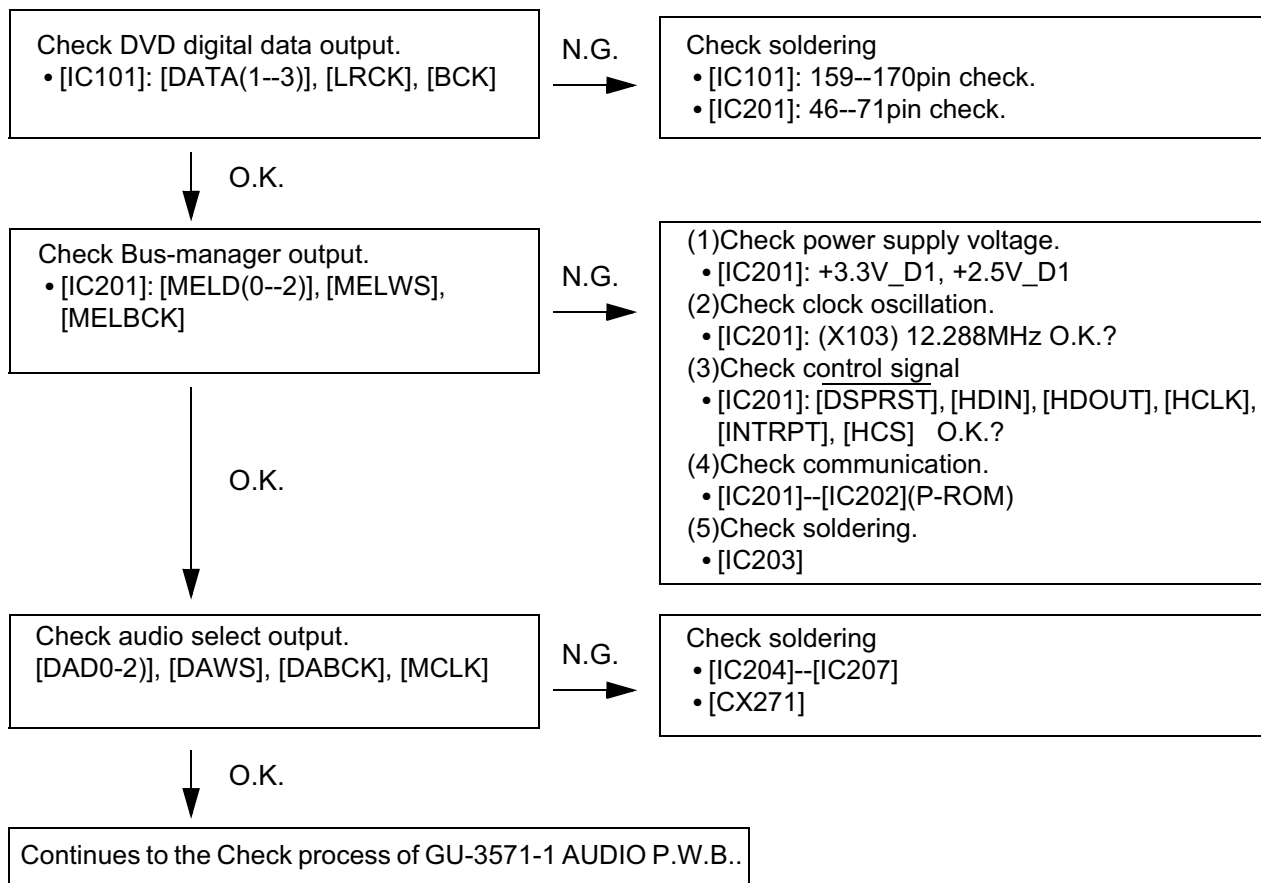
**2. GU-3571-1 AUDIO P.W.B.****2.1. No sound or Noise generated at audio output terminal.**

(1) Check Audio Output terminal, then Input pin of ICs.

- FL, FR → IC301 Audio input check See attached sheet waveform (WAVEFORMS ①~④)
- CNT, SW → IC302 Audio input check
- SL, SR → IC303 Audio input check

(2) Check MUTE Circuit and Transistors.

- Check MUTE circuit → Check Transistors (TR309--TR326)

2.2. Does not output Digital output signal(DOUT).

Check belows
 [IC201], [IC202]
 [T201], [JK201]

3. GU-3572 VIDEO PWB

(1) Progressive output does not outputed.

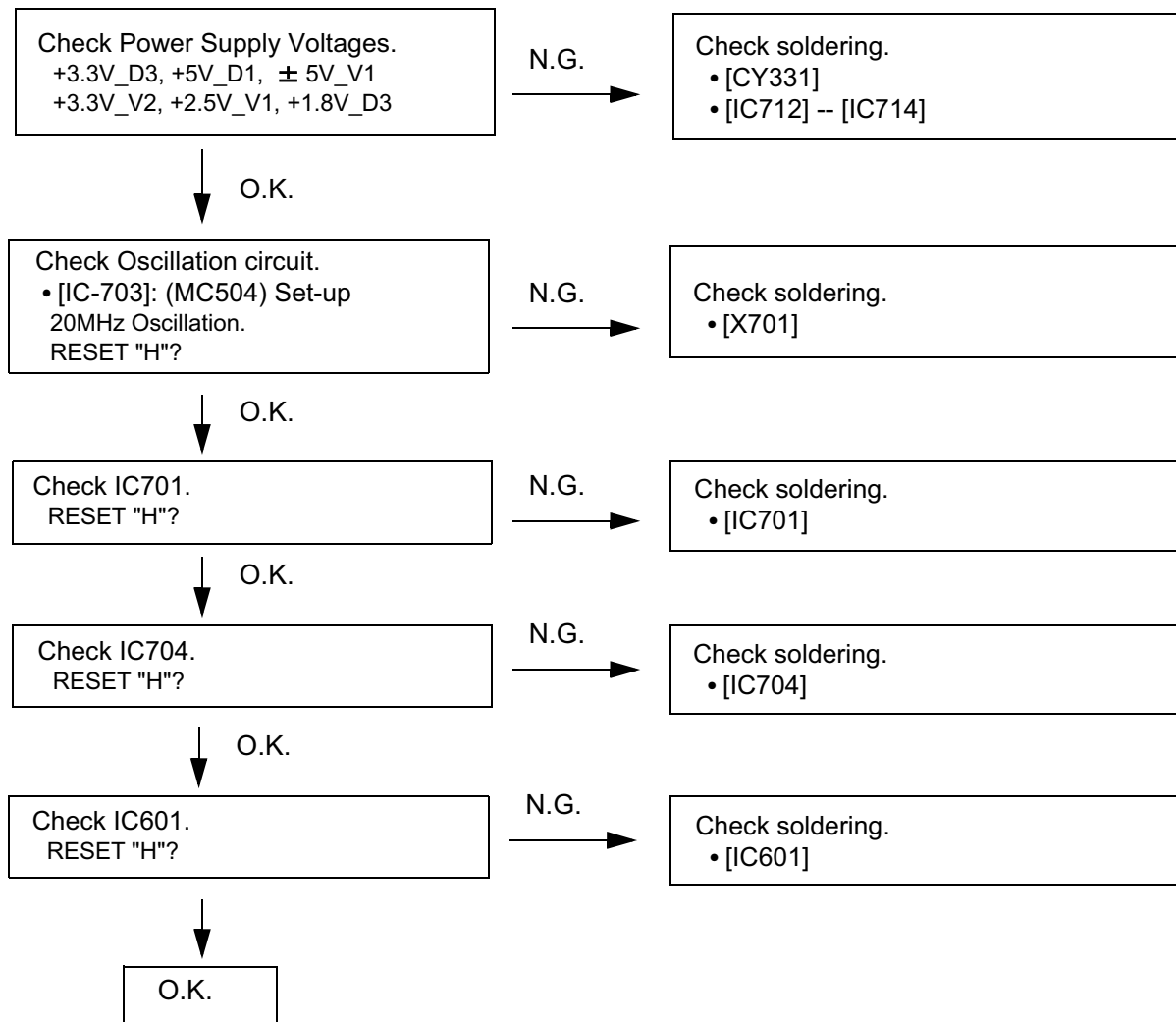

(2) Interlace output does not outputed.

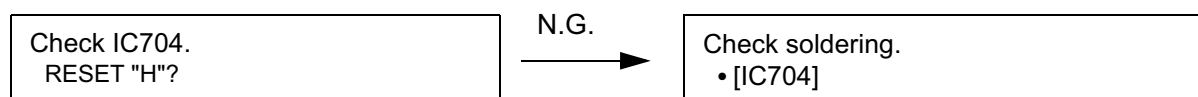

ELECTRICAL ADJUSTMENT FOR VIDEO

ビデオ回路の調整

1. SETTING

- (1) Connect the monitor TV to the video output terminal.
- (2) Connect the oscilloscope to the Y-signal and C-signal of S-VIDEO output terminal and each terminate at 75 Ohms.
- (3) Connect the oscilloscope to the Y-signal, Pb-signal and Pr-signal of Component video output terminal and each terminate at 75 Ohms.
※ **Use the 75 Ohms resistance must be 1%**
- (4) DVD test disc : DVDT-S01

2. BEFORE ADJUSTMENT

2.1. Setting the Oscilloscope as below.

- (1) Pb/Pr
 - (a) TIME/DIV : $2\mu\text{S}$
 - (b) VOLT/DIV : 100mV
(Use the probe : x10)
 - (2) Y/C
 - (a) TIME/DIV : $2\mu\text{S}$
 - (b) VOLT/DIV : 50mV
(Use the probe : x10)
- Power on. Power Supply
- | | | |
|--------------|---|------|
| USA & Canada | : | 120V |
| Europe | : | 230V |
| Japan | : | 100V |

2.2. Preparation

- (1) power on.
- (2) Set the [SOURCE] selector knob : DVD
- (3) Push [OPEN/CLOSE] button, then open the Disc Tray.
- (4) Set DVD test disc (DVDT-S01) on the Disc Tray, and then push [CLOSE] button.
- (5) FL display appear "STOP", push [PLAY] button to playback DVD.
- (6) Set the Video output to INTERLACED by remote control unit.
(Push the [SETUP] button, set to the mode of VIDEO SETUP.)
- (7) Push the [DISPLAY] button of remote control unit and then appear the ON-Screen Display (GUI) on the monitor TV.
- (8) Push the [12] button, select title 12 of DVD.
- (9) Push the [ENTER] button, playback title 12. (color bar 75%)

1. セッティング手順

- (1) セットの VIDEO OUT 端子にテレビモニターを接続する。
- (2) セットの S2 VIDEO OUT 端子から Y 信号と C 信号をそれぞれオシロスコープ (終端抵抗 : 75Ω) に接続する。
- (3) セットの COMPONENT VIDEO OUT の各端子 (Y/Pb/Pr) をそれぞれオシロスコープ (終端抵抗 : 75Ω) に接続する。
※ 75Ω 抵抗は 1%品を使用する事。
- (4) DVD テストディスク : DVDT-S01 を用意する。

2. 調整のまえに

2.1. オシロスコープを下記に設定する。

- (1) Pb/Pr
 - (a) TIME/DIV : $2\mu\text{S}$
 - (b) VOLT/DIV : 100mV
(プローブ x10 使用)
 - (2) Y/C
 - (a) TIME/DIV : $2\mu\text{S}$
 - (b) VOLT/DIV : 50mV
(プローブ x10 使用)
- 電源電圧 : 100V

2.2. 準備手順

- (1) セットの AC コードをコンセントへ挿入し、セットの電源を ON する。
- (2) セットの「OPEN/CLOSE」ボタンを押してトレイを開き、トレイ上に DVD テストディスク (DVDT-S1) をセット後、「CLOSE」ボタンを押す。
- (3) セット表示管上に「STOP」が表示されてから、PLAY ボタンを押して、ディスクを再生する。
- (4) リモコンで VIDEO 出力をインターレースモードに設定する。
- (5) リモコンの DISPLAY ボタンを押してグラフィカル・ユーザー・インターフェイス (GUI) 画面を出す。
- (6) 番号ボタンの「12」ボタンを押して、Title 12 を選択する。
- (7) 「ENTER」ボタンを押して、Title 12 を再生する (75% カラーバー信号)。

2.3. Procedure

- (1) Adjust the signal of S-VIDEO out by the wave of oscilloscope.

(a) Target, Y-signal

Point : VR704
Adjustment Value : $1000 \pm 20\text{mV}$
Waveform

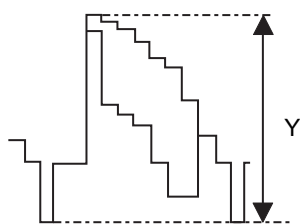

Y-signal of S-VIDEO out

(b) Target, C-signal

Point : VR705
Adjustment Value : $286 \pm 5\text{mV}$
Waveform

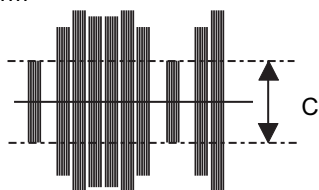

C-signal of S-VIDEO out

- (2) Set the Video output to PROGRESSIVE by remote control unit. (Push the [SETUP] button, set to the mode of VIDEO SETUP.)

(a) Target, Y-signal

Point : VR701
Adjustment Value : $1000 \pm 20\text{mV}$
Waveform

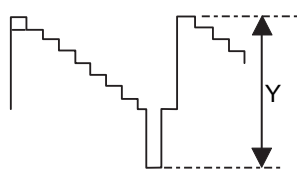

Y-signal

(b) Target, Pb-signal

Point : VR702
Adjustment Value : $*525 \pm 10\text{mV}$
Waveform

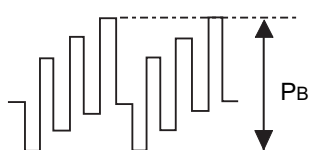

Pb-signal

2.3. 手順

- (1) セットの S2 VIDEO OUT の信号レベルをオシロスコープ上の波高値で調整する。

(a) Y 信号レベル

調整個所 : VR704
調整値 : $1000 \pm 20\text{mV}$
波形

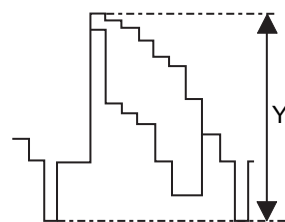

S2 VIDEO OUT の Y 信号レベル

(b) C 信号レベル

調整個所 : VR705
調整値 : $286 \pm 5\text{mV}$
波形

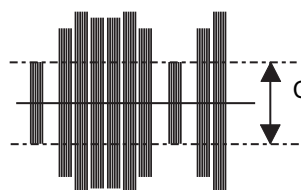

S2 VIDEO OUT の C 信号レベル

- (2) リモコンで VIDEO 出力をプログレッシブモードに設定する。

(a) Y 信号レベル

調整個所 : VR701
調整値 : $1000 \pm 20\text{mV}$
波形

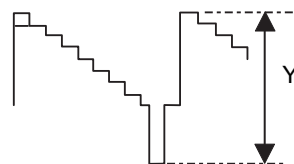

プログレッシブの Y 信号レベル

(b) Pb 信号レベル

調整個所 : VR702
調整値 : $525 \pm 10\text{mV}$
波形

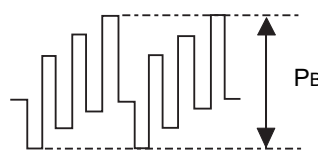

Pb 信号レベル

(c) Target, PR-signal

Point : VR703
 Adjustment Value : *525 ± 10mV
 Waveform

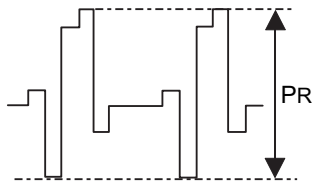

PR-signal

(c) PR 信号レベル

調整箇所 : VR703
 調整値 : 525 ± 10mV
 波形

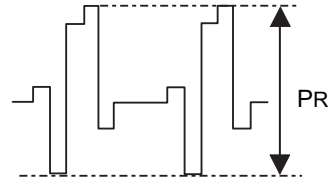

PR- 信号レベル

* : 486 ± 10mV for U.S.A. & Canada model

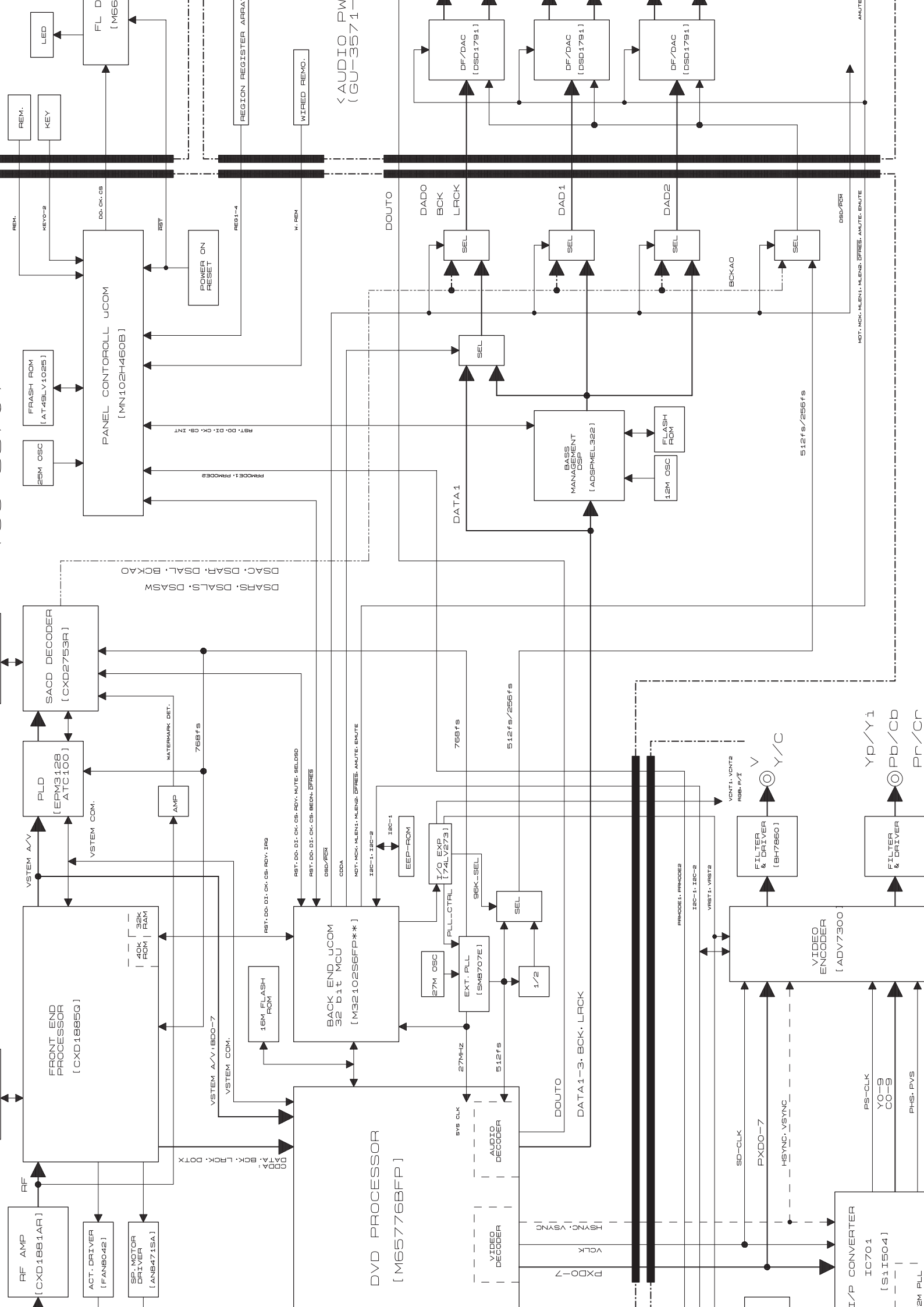

Block Diagram

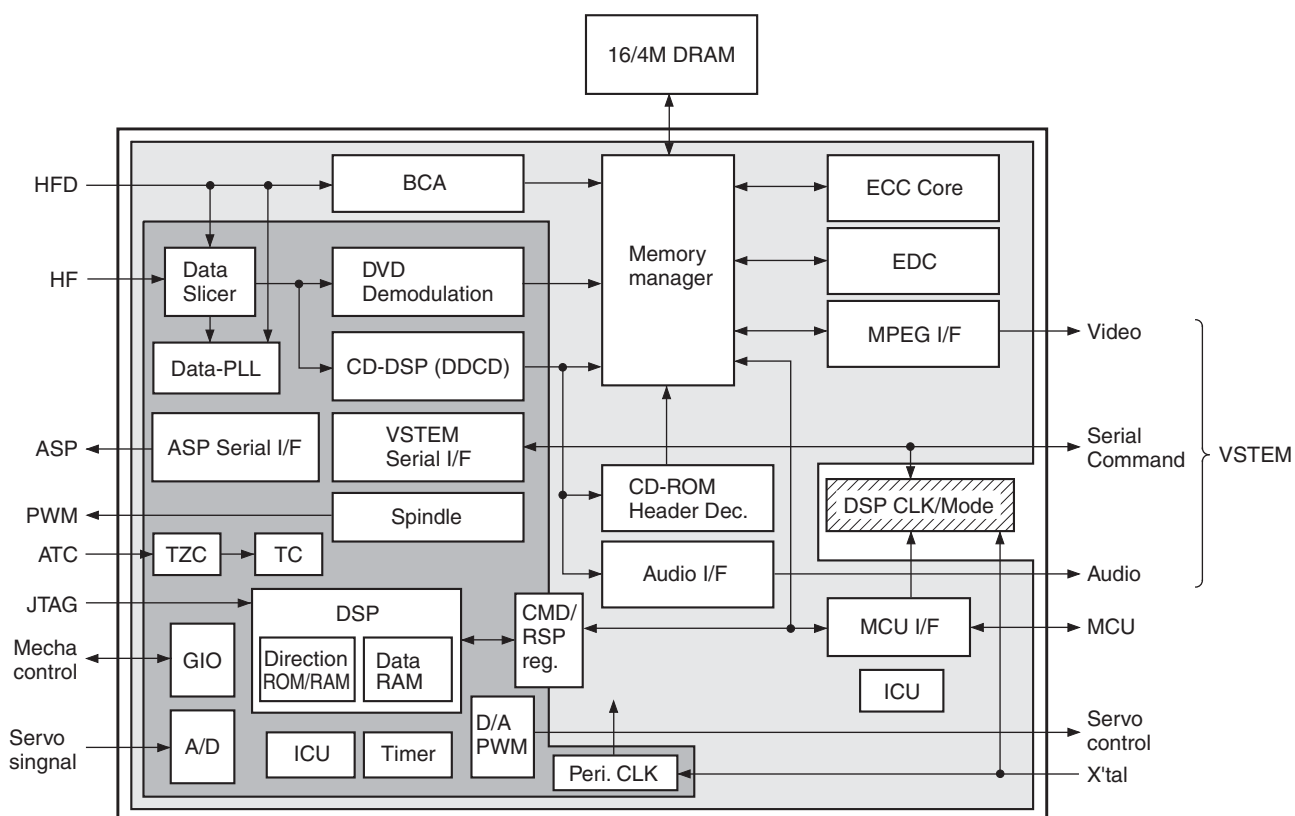

Functions

(A/D : Analog/Digital, PU : Pull-up, PD : Pull-down, SMT=Schumitt)

No.	Terminal Name	I/O	A/D	Classification	Function	PU	PD	SMT
1	DVDD33	P		V _{DD} & GND	Digital 3.3V Power for I/O.			
2	ALCR	I	D	MCU I/F	Chip select input. (L: Reset)	*		*
3	MSEL0	I	D	MCU I/F	MCU I/F mode select 0.			*
4	MSEL1	I	D	MCU I/F	MCU I/F mode select 1.			*
5	MA0	I/O	D	MCU I/F	MCU Address input 0 / data I/O 0 <LSB>.			*
6	MA1	I/O	D	MCU I/F	MCU Address input 1 / data I/O 1.			*
7	MA2	I/O	D	MCU I/F	MCU Address input 2 / data I/O 2.			*
8	MA3	I/O	D	MCU I/F	MCU Address input 3 / data I/O 3.			*
9	MA4	I/O	D	MCU I/F	MCU Address input 4 / data I/O 4.			*
10	MA5	I/O	D	MCU I/F	MCU Address input 5 / data I/O 5.			*
11	MA6	I/O	D	MCU I/F	MCU Address input 6 / data I/O 6.			*
12	MA7	I/O	D	MCU I/F	MCU Address input 7 / data I/O 7.			*
13	MA8	I	D	MCU I/F	MCU Address input 8 / data I/O 8 <MSB>.			*
14	TESTSEL	I	D	MCU I/F	TEST Select input.			*
15	MD0	I/O	D	MCU I/F	MCU data I/O 0 <LSB>.			*
16	MD1	I/O	D	MCU I/F	MCU data I/O 1.			*
17	MD2	I/O	D	MCU I/F	MCU data I/O 2.			*
18	MD3	I/O	D	MCU I/F	MCU data I/O 3.			*
19	MD4	I/O	D	MCU I/F	MCU data I/O 4.			*
20	MD5	I/O	D	MCU I/F	MCU data I/O 5.			*
21	DVSS	P		V _{DD} & GND	Digital Ground.			
22	MD6	I/O	D	MCU I/F	MCU data I/O 6.			*
23	MD7	I/O	D	MCU I/F	MCU data I/O 7 <MSB>.			*
24	MALE	I	D	MCU I/F	MCU Address latch signal input.			*
25	MCS	I	D	MCU I/F	MCU Chip Select signal input.			*
26	MWR	I	D	MCU I/F	MCU Write strobe signal.			*
27	DVDD33	P		V _{DD} & GND	digital 3.3V Power. (for I/O)			
28	MRD	I	D	MCU I/F	MCU Read Strobe signal.			*
29	MRDY	O	D	MCU I/F	MCU Ready signal. (L: Wait)			
30	MINT	O	D	MCU I/F	MCU Interrupt signal. (L: Interrupt request)			
31	SYSCK	O	D	MCU I/F	Clock Monitor output.			

No.	Terminal Name	I/O	A/D	Classification	Function	PU	PD	SMT
32	DVDD18	P		VDD & GND	Digital 1.8V Power. (Internal logic system power)			
33	XI	I	D	Clock	Crystal oscillation input.			
34	XO	O	D	Clock	Crystal oscillation output.			
35	DVSS	P		VDD & GND	Digital Ground.			
36	VDT7	O	D	VSTEM A/V	MPEG data output 7.			
37	VTD6	O	D	VSTEM A/V	MPEG data output 6.			
38	DVSS	P		VDD & GND	Digital Ground.			
39	VDT5	O	D	VSTEM A/V	MPEG data output 5.			
40	VDT4	O	D	VSTEM A/V	MPEG data output 4.			
41	VDT3	O	D	VSTEM A/V	MPEG data output 3.			
42	VDT2	O	D	VSTEM A/V	MPEG data output 2.			
43	VDT1	O	D	VSTEM A/V	MPEG data output 1.			
44	VDT0	O	D	VSTEM A/V	MPEG data output 0.			
45	HDRQ	I	D	VSTEM A/V	MPEG data Request input.	*		
46	XHAC	O	D	VSTEM A/V	Data Valid output.			
47	VEFG	O	D	VSTEM A/V	ECC Error sector Flag output. (L: error sector)			
48	XSHD	O	D	VSTEM A/V	DVD Sector Head Flag output.			
49	DCK	O	D	VSTEM A/V	Data Strobe output.			
50	DRVIRQ	O	D	VSTM Commad	Interrupt Request output for Host. (L: interruption is demanded)			
51	DRVRST	I	D	VSTM Commad	Drive H/W Reset input. (L: reset)	*		*
52	DVDD18	P		VDD & GND	Digital 1.8V power for Internal logic system.			
53	DVDD33	P		VDD & GND	Digital 3.3V Power for I/O.			
54	DRVTX	O	D	VSTM Com mand	Transmitting serial data output to Host.			
55	DRVRX	I	D	VSTM Com mand	Reception serial data input from Host.			
56	DRVCLK	I	D	VSTM Com mand	Clock input from Host.			*
57	DRVRDY	O	D	VSTM Com mand	Drive Ready signal output. (L: ready)			
58	C2PO	O	D	Audio I/F	CD DSP C2 Pointer output.			
59	DADT	O	D	Audio I/F	Audio serial data output.			
60	DOTX	O	D	Audio I/F	Digital audio output.			
61	LRCK	O	D	Audio I/F	L/R Clock output.			
62	BCK	O	D	Audio I/F	Audio Bit Clock output.			
63	EXVCO	I	D	TEST/Monitor	External Channel clock input.			
64	EXPLDT	I	D	TEST/Monitor	External RF data input.			
65	CSL	O	D	ASP I/F	SIO for RF signal processing LSI control. Ratch signal output.			
66	SI	I	D	ASP I/F	SIO for RF signal processing LSI control. Serial data input.			
67	SO	O	D	ASP I/F	SIO for RF signal processing LSI control. Serial data output.			
68	SCLKH	O	D	ASP I/F	SIO for RF signal processing LSI control. Serial clock output.			
69	RFOKGH	I	D	ASP I/F	RF O.K. Signal input.			*
70	HFD	I	D	ASP I/F	RF lack Signal input.			*
71	MIRRORH	I	D	ASP I/F	Mirror detected signal input.(H: Mirror detected)			*
72	DTC	I	D	ASP I/F	Track cross signal input. (Logic level input)			*
73	AVSS	P		VDD & GND	Analog Ground.			
74	ATC	I	A	Data PLL	Track Cross signal input. (Analog level input)			
75	HF	I	A	Data PLL	RF signal input.			
76	TLC0	O	A	Data PLL	Asymmetry Charge pump output 0.			
77	TLC1	O	A	Data PLL	Asymmetry Charge pump output 1			
78	IREF	I	A	Data PLL	Reference current setting terminal for Asymmetry Circuit.			
79	AVDD33	P		VDD & GND	Analog 3.3V Power.			
80	JMREF	I	A	Data PLL	Reference current setting terminal for Jitter Monitor			
81	JMOUT	O	A	Data PLL	Jitter Monitor output.			
82	CHG	I	A	Data PLL	Reference current setting terminal for data PLL.			
83	VFBC	I	A	Data PLL	VCO offset frequency setting terminal for data PLL.			
84	AVDD18	P		VDD & GND	Analog 1.8V Power.			
85	VCOI	I	A	Data PLL	VCO Control voltage input terminal for data PLL.			
86	LPF1	O	A	Data PLL	VCO Loop filter connection terminal 1 for data PLL.			
87	LPF2	O	A	Data PLL	VCO Loop filter connection terminal 2 for data PLL			
88	RC	I	A	Data PLL	VCO gain setting terminal for data PLL.			
89	AVSS	P		VDD & GND	Analog Ground.			

No.	Terminal Name	I/O	A/D	Classification	Function	PU	PD	SMT
90	AVss	P		V _{DD} & GND	Analog Ground.			
91	AD0	I	A	ADC	AD0 Input.			
92	AD1	I	A	ADC	AD1 Input.			
93	AD2	I	A	ADC	AD2 Input.			
94	AV _{DD33}	P		V _{DD} & GND	Analog 3.3V Power.			
95	AD3	I	A	ADC	AD3 Input.			
96	AD4	I	A	ADC	AD4 Input.			
97	AD5	I	A	ADC	AD5 Input.			
98	AD6	I	A	ADC	AD6 Input.			
99	AD7	I	A	ADC	AD7 Input.			
100	AD8	I	A	ADC	AD8 Input.			
101	AD9	I	A	ADC	AD9 Input.			
102	VREFH	I/O	A	ADC	Max Reference Voltage input for ADC. (Internal Reference Voltage mode, it will be an output state)			
103	VREFL	I/O	A	ADC	Min. Reference Voltage input for ADC. (Internal Reference Voltage mode, it will be an output state)			
104	AV _{DD18}	P		V _{DD} & GND	Analog 1.8V Power.			
105	AV _{DD33}	P		V _{DD} & GND	Analog 3.3V Power.			
106	DA0 (TSCON)	O	A	DAC	DA0 output. (Track Servo output)			
107	DA1 (SLED)	O	A	DAC	DA1 output. (Sled Servo output)			
108	DA2 (FSCON)	O	A	DAC	DA2 output. (Focus Servo output)			
109	DA3 (SLED2_TILT)	O	A	DAC	DA3 output. (Sled Servo / Tilt Servo output)			
110	AVss	P		V _{DD} & GND	Analog Ground			
111	FG	I	D	SPM	FG signal input.			*
112	SPWM1	O	D	SPM	Spindle motor PWM output 1.			
113	SPWM2	O	D	SPM	Spindle motor PWM output 2.			
114	GPWM0	O	D	General PWM	Multi purpose PWM output 0.			
115	GPWM1	O	D	General PWM	Multi purpose PWM output 1.			
116	GPWM2	O	D	General PWM	Multi purpose PWM output 2.			
117	GPWM3	O	D	General PWM	Multi purpose PWM output 3.			
118	GPWM4	O	D	General PWM	Multi purpose PWM output 4.			
119	GPWM5	O	D	General PWM	Multi purpose PWM output 5.			
120	XLCAS	O	D	DRAM I/F	DRAM LCAS output. (Low Byte row address strobe output)			
121	XUCAS	O	D	DRAM I/F	DRAM LCAS output. (Upper Byte row address strobe output)			
122	XMOE	O	D	DRAM I/F	DRAM output enable.			
123	RA11	O	D	DRAM I/F	DAM address output terminal 11.			
124	RA10	O	D	DRAM I/F	DAM address output terminal 10.			
125	DVss	P		V _{DD} & GND	Digital Ground.			
126	RA9	O	D	DRAM I/F	DAM address output terminal 9.			
127	RA8	O	D	DRAM I/F	DAM address output terminal 8.			
128	RA7	O	D	DRAM I/F	DAM address output terminal 7.			
129	RA6	O	D	DRAM I/F	DAM address output terminal 6.			
130	RA5	O	D	DRAM I/F	DAM address output terminal 5.			
131	DV _{DD33}	P		V _{DD} & GND	Digital 3.3V Power. (for I/O)			
132	RA4	O	D	DRAM I/F	DAM address output terminal 4.			
133	RA3	O	D	DRAM I/F	DAM address output terminal 3.			
134	RA2	O	D	DRAM I/F	DAM address output terminal 2.			
135	RA1	O	D	DRAM I/F	DAM address output terminal 1.			
136	DV _{DD18}	P		V _{DD} & GND	Digital 1.8V Power. (for Internal Logic power)			
137	RA0	O	D	DRAM I/F	DAM address output terminal 0.			
138	XRAS	O	D	DRAM I/F	DRAM RAS output. (Column address strobe output)			
139	XMWR	O	D	DRAM I/F	DRAM Write enable.			
140	RD7	I/O	D	DRAM I/F	DRAM data input/output terminal 7.	*		
141	RD6	I/O	D	DRAM I/F	DRAM data input/output terminal 6.	*		
142	DVss	P		V _{DD} & GND	Digital Ground.			
143	RD5	I/O	D	DRAM I/F	DRAM data input/output terminal 5.	*		
144	RD4	I/O	D	DRAM I/F	DRAM data input/output terminal 4.	*		
145	RD3	I/O	D	DRAM I/F	DRAM data input/output terminal 3.	*		
146	RD2	I/O	D	DRAM I/F	DRAM data input/output terminal 2.	*		
147	RD1	I/O	D	DRAM I/F	DRAM data input/output terminal 1.	*		
148	RD0	I/O	D	DRAM I/F	DRAM data input/output terminal 0.	*		

No.	Terminal Name	I/O	A/D	Classification	Function	PU	PD	SMT
149	RD15	I/O	D	DRAM I/F	DRAM data input/output terminal 15.	*		
150	RD14	I/O	D	DRAM I/F	DRAM data input/output terminal 14.	*		
151	RD13	I/O	D	DRAM I/F	DRAM data input/output terminal 13.	*		
152	RD12	I/O	D	DRAM I/F	DRAM data input/output terminal 12.	*		
153	RD11	I/O	D	DRAM I/F	DRAM data input/output terminal 11.	*		
154	RD10	I/O	D	DRAM I/F	DRAM data input/output terminal 10.	*		
155	RD9	I/O	D	DRAM I/F	DRAM data input/output terminal 9.	*		
156	DVDD18	P		VDD & GND	Digital 1.8V Power. (for internal Logic system)			
157	DVDD33	P		VDD & GND	Digital 3.3V power for I/O.			
158	RD8	I/O	D	DRAM I/F	DRAM data input/output terminal 8.	*		
159	TEST0	O	D	TEST Monitor	TEST I/O 0.			
160	TEST1	O	D	TEST Monitor	TEST I/O 1.			
161	TEST2	O	D	TEST Monitor	TEST I/O 2.			
162	TEST3	O	D	TEST Monitor	TEST I/O 3.			
163	TEST4	O	D	TEST Monitor	TEST I/O 4.			
164	TEST5	O	D	TEST Monitor	TEST I/O 5.			
165	TEST6	O	D	TEST Monitor	TEST I/O 6.			
166	TEST7	O	D	TEST Monitor	TEST I/O 7.			
167	TEST8	O	D	TEST Monitor	TEST I/O 8.			
168	TEST9	O	D	TEST Monitor	TEST I/O 9.			
169	TEST10	O	D	TEST Monitor	TEST I/O 10.			
170	TEST11	O	D	TEST Monitor	TEST I/O 11.			
171	TEST12	O	D	TEST Monitor	TEST I/O 12.			
172	TEST13	O	D	TEST Monitor	TEST I/O 13.			
173	TEST14	O	D	TEST Monitor	TEST I/O 14.			
174	TEST15	O	D	TEST Monitor	TEST I/O 15.			
175	MODSEL0	I	D	TEST Monitor	TEST mode select 0. (GND, under normal conditions)			
176	MODSEL1	I	D	TEST Monitor	TEST mode select 1. (GND, under normal conditions)			
177	DVss	P		VDD & GND	Digital Ground.			
178	MODSEL2	I	D	TEST Monitor	TEST mode select 2. (GND, under normal conditions)			
179	GIO0	I/O	D	Multi purpose	Multi purpose port 0.		*	*
180	GIO1	I/O	D	Multi purpose	Multi purpose port 1.		*	*
181	GIO2	I/O	D	Multi purpose	Multi purpose port 2.		*	*
182	GIO3	I/O	D	Multi purpose	Multi purpose port 3.		*	*
183	DVDD33	P		VDD & GND	Digital 3.3V Power for I/O.			
184	GIO4	I/O	D	General Port	Multi purpose port 4.		*	*
185	GIO5	I/O	D	General Port	Multi purpose port 5.		*	*
186	GIO6	I/O	D	General Port	Multi purpose port 6.		*	*
187	GIO7	I/O	D	General Port	Multi purpose port 7.		*	*
188	DVDD18	P		VDD & GND	Digital 1.8V Power for I/O.			
189	GIO8	I/O	D	General Port	Multi purpose port 8.		*	*
190	GIO9	I/O	D	General Port	Multi purpose port 9.	*	*	*
191	GIO10	I/O	D	General Port	Multi purpose port 10.		*	*
192	GIO11	I/O	D	General Port	Multi purpose port 11.		*	*
193	GIO12	I/O	D	General Port	Multi purpose port 12.	*	*	*
194	DVss	P		VDD & GND	Digital Ground.			
195	GIO13	I/O	D	Multi purpose	Multi purpose port 13.	*	*	*
196	GIO14	I/O	D	General Port	Multi purpose port 14.	*	*	*
197	GIO15	I/O	D	General Port	Multi purpose port 15.	*	*	*
198	GIO16	I/O	D	General Port	Multi purpose port 16.		*	*
199	GIO17	I/O	D	General Port	Multi purpose port 17.		*	*
200	GIO18	I/O	D	General Port	Multi purpose port 18.		*	*
201	GIO19	I/O	D	General Port	Multi purpose port 19.		*	*
202	TRST	I	D	JTAG I/F	JTAG I/F Reset input.		*	*
203	TMS	I	D	JTAG I/F	JTAG Mode Select input.	*		*
204	TDI	I	D	JTAG I/F	JTAG Data Input.	*		*
205	TCK	I	D	JTAG I/F	JTAG Clock input.	*		
206	TDO	O	D	JTAG I/F	JTAG Data output.			
207	VMCHG	I	D	MCU I/F	VSTEM / external MCU access selection terminal of system setting register for DSP.			
208	DVDD18	P		VDD & GND	Digital 1.8V power for internal Logic system.			

M65776BFP (MA:IC101)

Top View

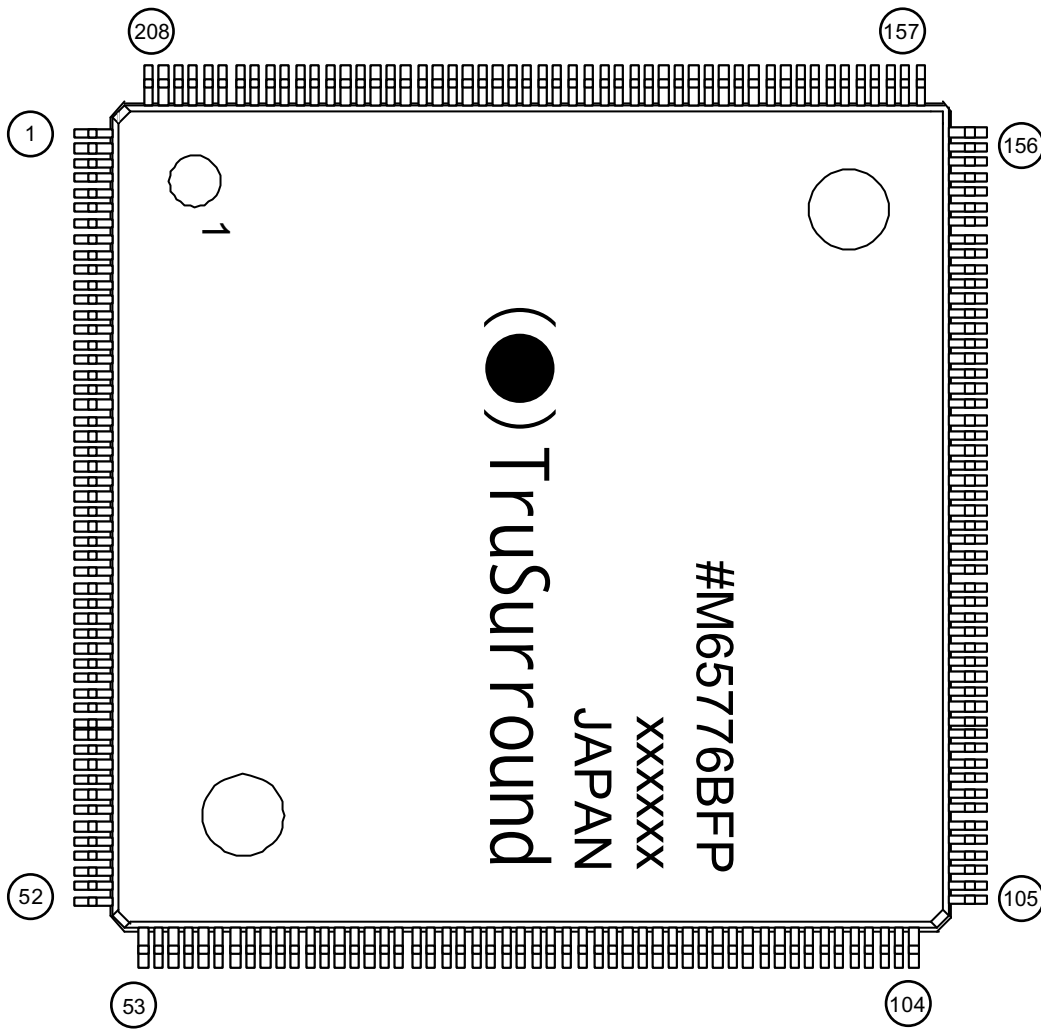

Pin Assignment

No	Name	I/O	No	Name	I/O	No	Name	I/O	No	Name	I/O
1	GND	-	53	MA[3]	O	105	CLKO	O	157	PDR[8]	O
2	BCLK	I	54	MA[4]	O	106	CLKIN	I	158	PDR[9]	O
3	BDEN	I	55	MA[2]	O	107	AVDD18	-	159	LRCLK	O
4	BDREQ	O	56	VDD18	-	108	AGND18	-	160	CDLRCK	I
5	BSECH	I	57	VDD33	-	109	NCO	NC	161	CDBCK	I
6	HD[0]	I/O	58	MA[5]	O	110	NCO	NC	162	CDDATA	I
7	HD[1]	I/O	59	MA[1]	O	111	NCO	NC	163	CDDIN	I
8	HD[2]	I/O	60	MA[6]	O	112	GND	-	164	AO0	O
9	HD[3]	I/O	61	MA[0]	O	113	AVDD33	-	165	GND	-
10	HD[4]	I/O	62	MA[7]	O	114	DAOUTB	AO	166	AO1	O
11	HD[5]	I/O	63	MA[10]	O	115	AVRI	AI	167	AO2	O
12	VDD18	-	64	GND	-	116	PAB	AO	168	AOD	O
13	VDD33	-	65	MA[8]	O	117	IREF	AI	169	AAD	O
14	HD[6]	I/O	66	MBA[1]	O	118	BIAS2	AI	170	DOUT0	O
15	HD[7]	I/O	67	MA[9]	O	119	PAY	AO	171	DOUT1	O
16	HD[8]	I/O	68	MBA[0]	O	120	BIAS1	AI	172	ACLK1	I
17	HD[9]	I/O	69	MA[11]	O	121	AVDD33	-	173	DACCLK	O
18	HD[10]	I/O	70	DCS	O	122	PAR	AO	174	VDD18	-
19	HD[11]	I/O	71	VDD18	-	123	AVDD33	-	175	VDD33	-
20	GND	-	72	VDD33	-	124	AGND33	-	176	DOCLK	O
21	HD[12]	I/O	73	DCS2	O	125	GND	-	177	PWD	TO
22	HD[13]	I/O	74	DCS3	O	126	NCO	NC	178	CSYNC	I
23	HD[14]	I/O	75	DCS4	O	127	NCO	NC	179	OSDKEY	O
24	HD[15]	I/O	76	DCS5	O	128	NCO	NC	180	VSYN	O
25	HA[0]	I	77	RAS	O	129	NCO	NC	181	HSYN	O
26	HA[1]	I	78	CAS	O	130	NCO	NC	182	PXCLKP	O
27	VDD18	-	79	MCLK	O	131	NCO	NC	183	PXCLK	O
28	VDD33	-	80	DWE	O	132	NCO	NC	184	PD[0]	O
29	HA[2]	I	81	GND	-	133	NCO	NC	185	PD[1]	O
30	HA[3]	I	82	DQMU	O	134	VDD18	-	186	PD[2]	O
31	HA[4]	I	83	DQML	O	135	VDD33	-	187	GND	-
32	HA[5]	I	84	MD[7]	I/O	136	NCO	NC	188	PD[3]	O
33	HA[6]	I	85	MD[8]	I/O	137	NCO	NC	189	PD[4]	O
34	HA[7]	I	86	MD[6]	I/O	138	NCO	NC	190	PD[5]	O
35	GND	-	87	MD[9]	I/O	139	NCO	NC	191	PD[6]	O
36	HA[8]	I	88	VDD18	-	140	NCO	NC	192	PD[7]	O
37	HA[9]	I	89	VDD33	-	141	NCO	NC	193	RESET	I
38	HA[10]	I	90	MD[5]	I/O	142	NCO	NC	194	HMODE[0]	I
39	HA[11]	I	91	MD[10]	I/O	143	NCO	NC	195	HMODE[1]	I
40	CS	I	92	MD[4]	I/O	144	NCO	NC	196	TEST[0]	I
41	RE	I	93	MD[11]	I/O	145	GND	-	197	TEST[1]	I
42	VDD18	-	94	MD[3]	I/O	146	NCO	NC	198	VDD18	-
43	VDD33	-	95	MD[12]	I/O	147	NCO	NC	199	VDD33	-
44	WE	I	96	GND	-	148	NCO	NC	200	TEST[2]	I
45	BHE	I	97	MD[2]	I/O	149	NCO	NC	201	BD[0]	I
46	RDY	TO	98	MD[13]	I/O	150	NCO	NC	202	BD[1]	I
47	INT1	O	99	MD[1]	I/O	151	NCO	NC	203	BD[2]	I
48	INT2	O	100	MD[14]	I/O	152	NCO	NC	204	BD[3]	I
49	INT3	O	101	MD[0]	I/O	153	NCO	NC	205	BD[4]	I
50	GND	-	102	MD[15]	I/O	154	NCO	NC	206	BD[5]	I
51	DREQ	O	103	VDD18	-	155	VDD18	-	207	BD[6]	I
52	DACK	I	104	VDD33	-	156	VDD33	-	208	BD[7]	I

NC: NO Connection
TO: Tri-State Output
AO: Analog Output
AI: Analog Input

Functions (Bit stream interface / SDRAM interfacial)

PIN Name	I/O	Functions
BD[7:0]	I	Bit Stream data input.
BCLK	I	Strobe Signal from BD.
BDEN	I	The validity of the data extracted from BD is checked.
BDREQ	O	Data Request signal.
BSECH	I	Directs whether the data of BD is the head byte of a selector.
MD[15:0]	I/O	Data bus line with SDRAM
MA[11:0]	O	SDRAM Address bus line
MBA[1:0]	O	SDRAM Bank select line.
DCS	O	SDRAM Chip select.
DCS2	O	SDRAM Chip select.
DCS3	O	SDRAM Chip select.
DCS4	O	SDRAM Chip select.
DCS5	O	SDRAM Chip select.
RAS	O	SDRAM RAS (Row Address Strobe) control.
CAS	O	SDRAM CAS (Column Address Strobe) control.
DQMU	O	SDRAM DQM control.
DQML	O	SDRAM DQM control.
DWE	O	SDRAM WE control.
MCLK	O	SDRAM operation clock.

Functions (Video output interface)

PIN Name	I/O	Functions
PXCLK	O	Pixel Clock, 27 MHz.
PXCLKP	O	Pixel Clock, 54 MHz.
PD[7:0]	O	Digital Pixel Data.
CSYNC	I	Composite SYNC signal input.
OSDKEY	O	OSD Key flag output.
PWD	O	Phase detector output for external synchronous operation.
HSYNC	O	Horizontal SYNC output.
VSYNC	O	Vertical SYNC output.

Functions (Audio output interface)

PIN Name	I/O	Functions
A00	O	Serial PCM data for DAC.
A01	O	Serial PCM data for DAC.
A02	O	Serial PCM data for DAC.
A0D	O	Serial PCM data for DAC.
AAD	O	Ancillary data output.
DOCLK	O	PCM bit Clock.
LRCLK	O	Channel Clock output for audio playback.
DACCLK	O	Over sampling Clock for DAC.
CDBCK	I	PCM Bit Clock inputted from CDDSP.
CDLRCK	I	L/R Clock inputted from CDDSP.
CDDIN	I	PCM audio data inputted from CDDSP.
CDATA	I	Digital audio interface input.
DOU0	O	Digital audio interface output.
DOU1	O	Digital audio interface output

Functions (Host interface)

Pin Name	I/O	Functions
HD[15:0]	I/O	Data I/O.
HA[11:0]	I	Address input.
BHE	I	Byte High Enable.
RE	I	Read Enable.
WE	I	Write Enable.
CS	I	Chip Select.
RDY	O	Acknowledge signal which shows that read out or the writing of data was completed.
INTR INT2 INT3	O	Interruption request signal over external CPU from M65776AFP. "L" is outputted at the time of interruption generating and "H" is outputted when other.
DREQ	O	DMA request signal for bit map transmission.
DACK	I	DMA acknowledge signal for bit map transmission.
HMODE[1:0]	I	Host interface operation mode setting.
HMODE[2]	I	It fixed to "L" potential..

Video DAC

Pin Name	I/O	Functions
IREF	I	Reference current input.
AVRI	I	Reference voltage input.
BIAS1	I	Bias voltage for the source of current.
BIAS2	I	Bias voltage for the source of current.
PAY	O	Analog current output.(for Y)
PAB	O	Analog current output.(for Pb)
PAC	O	Analog current output.(for Pr)
DAOUTB	O	It fixed to Analog Ground..
AVDD33	Power	+3.3V Analog Power supply.
AGND33	Power	Analog Ground.

System service

Pin Name	I/O	Functions
CLKIN	I	27 MHz, system Clock input.
CLKO	O	27 MHz, Clock output.
ACLKI	I	Audio Clock input.
RESET	I	Hardware Reset.
TEST[2:0]	I	It fixed to "L" potential.
VDD18	Power	+1.8 V Power for internal.
VDD33	Power	+3.3 V Power for internal interface.
GND	Power	Ground.
AVDD18	Power	+1.8 V Power for internal PLL.
AGND18	Power	It fixed to Ground. Ground for internal PLL.

SiI504CM208 (VC: IC701)

Top View

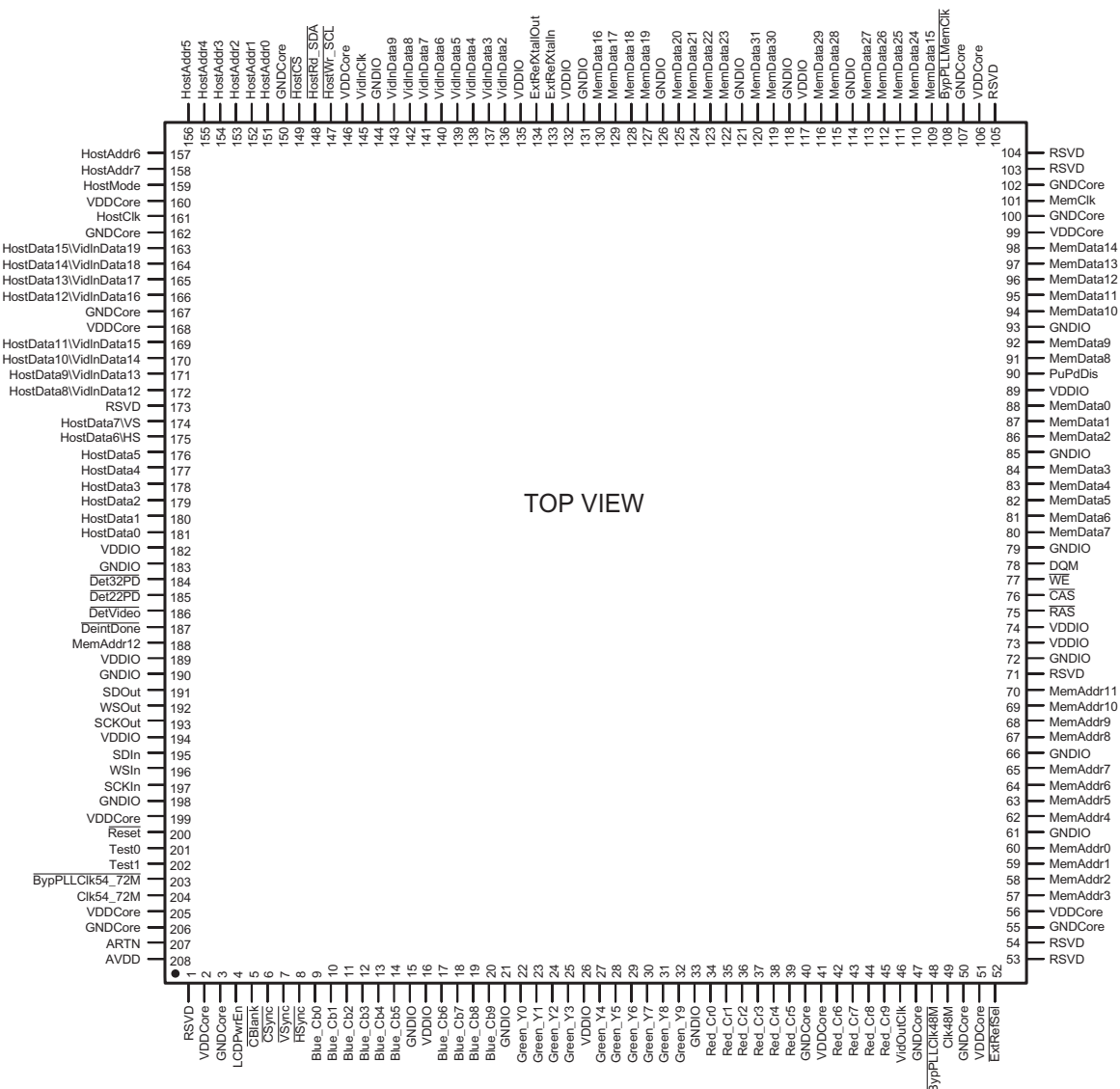

SiI504CM208 Terminal Function

Pin No.	Pin Name	I/O	Function
2, 41, 51, 56, 99, 106, 146, 160, 168, 199, 205	VDDCore	Pwr	1.8V Core Power.
3, 40, 47, 50, 55, 100, 102, 107, 150, 162, 167, 206	GNDCore	Pwr	Digital Ground for Core Power.
4	LCDPwrEn	Out	LCD Power Enable
5	CBlank	Out	Composite Blank
6	CSync	Out	Composite Sync
7	VSync	Out	Vertical Sync
8	HSync	Out	Horizontal Sync
9~14, 17~20	Blue_Cb[9:0]	Out	Blue Data (RGB output mode); Cb Data (YCrCb output mode)
15, 21, 33, 61, 66, 72, 79, 85, 93, 114, 118, 121, 126, 131, 144, 183, 190, 198	GNDIO	Pwr	Digital Ground for I/O Power.

Pin No.	Pin Name	I/O	Function
16, 26, 73, 74, 89, 117, 132, 135, 182, 189, 194	VDDIO	Pwr	3.3V I/O Power.
22~25, 27~32	Green_Y[9:0]	Out	Green Data (RGB output mode); Y Data (YCrCb output mode)
34~39, 42~45	Red_Cr[9:0]	Out	Red Data (RGB output mode); Cr Data (YCrCb output mode)
46	VidOutClk	Out	Video Output Clock, 36, 27 or 24 MHZ
48	ByPLLClk48M	In	Bypass PLL for Clk48M.
49	Clk48M	InOut	48 MHz Clock.
52	ExtRefSel	In	External APLL Reference Select.
57~60, 62~65, 67~70, 188	MemAddr[12:0]	InOut	SDRAM Address when an output. Configuration at reset when an input.
75	RAS	Out	SDRAM Row Address Strobe.
76	CAS	Out	SDRAM Column Address Strobe.
77	WE	Out	SDRAM Write Enable.
78	DQM	Out	SDRAM Data Mask.
80~84, 86~88, 91, 92, 94~98, 109, 110~113, 115, 116, 119, 120, 122~125, 127~130	MemData[31:0]	InOut	SDRAM Data.
90	PuPdDis	In	Internal pullup and pulldown disable test function.
101	MemClk	InOut	SDRAM Clock.
108	ByPLLMemClk	In	Bypass PLL for MemClk.
133	ExtRefXtalIn	In	External APLL Reference Crystal/oscillator Input.
134	ExtRefXtalOut	Out	External APLL Reference Crystal Output.
136~143	VidInData[9:2]	In	Multiplexed Video Input Data; Y Video Input Data.
145	VidInClk	In	Video Input Clock, 27.0 MHz
147	HostWr_SCL	In	186-Compatible Write when HostMode=0. Serial Clock when HostMode=1.
148	HostRd_SDA	InOut	186-Compatible Read when HostMode=0. Serial Data when HostMode=1.
149	HostCS	In	186-Compatible Chip Select when HostMode=0. When HostMode=1, must be tied to VDD or pulled up to VDD.
151~158	HostAddr[7:0]	In	186-Compatible Address when HostMode=0. No connect when HostMode=1.
159	HostMode	In	Serial Host Interface when HostMode=1. 186-compatible host interface when HostMode=0.
161	HostClk	InOut	186-Compatible Clock when HostMode=0. No connect when HostMode=1.
163~166, 169~172	HostData[15:8] (VidInData[19:2])	InOut	186-Compatible Data when HostMode=0. Chroma video input data when HostMode=1.
174	HostData[7](VS)	InOut	186-Compatible Data when HostMode=0. Vertical sync input when HostMode=1.
175	HostData[6](HS)	InOut	186-Compatible Data when HostMode=0. Horizontal sync input when HostMode=1.
176~181	HostData[5:0]	InOut	186-Compatible Data when HostMode=0. No connect when HostMode=1.
184	Det32PD	Out	3:2 Pulldown Sequence Detected.
185	Det22PD	Out	2:2 Pulldown Sequence Detected.
186	DetVideo	Out	Interlaced Video Sequence Detected.
187	DeintDone	Out	Deinterlace processing complete for current field period.
191	SDOut	Out	Serial Digital Audio Output Data.
192	WSOut	Out	Serial Digital Audio Output Word Select.
193	SCKOut	Out	Serial Digital Audio Output Clock.
195	SDIn	In	Serial Digital Audio Input Data.
196	WSIn	In	Serial Digital Audio Input Word Select.
197	SCKIn	In	Serial Digital Audio Input Clock.
200	Reset	In	Hardware Reset.
201, 202	Test[1:0]	In	Production hardware test support.
203	ByPLLClk54_72M	In	Bypass PLL for Clk54_72M.
204	Clk54_72M	InOut	54 or 72 MHz Clock.
207	ARTN	Pwr	Analog Return for PLLs.
208	AVDD	Pwr	1.8V Analog Power for PLL.

CXD2753R (MA: IC401)

Pin Assignment

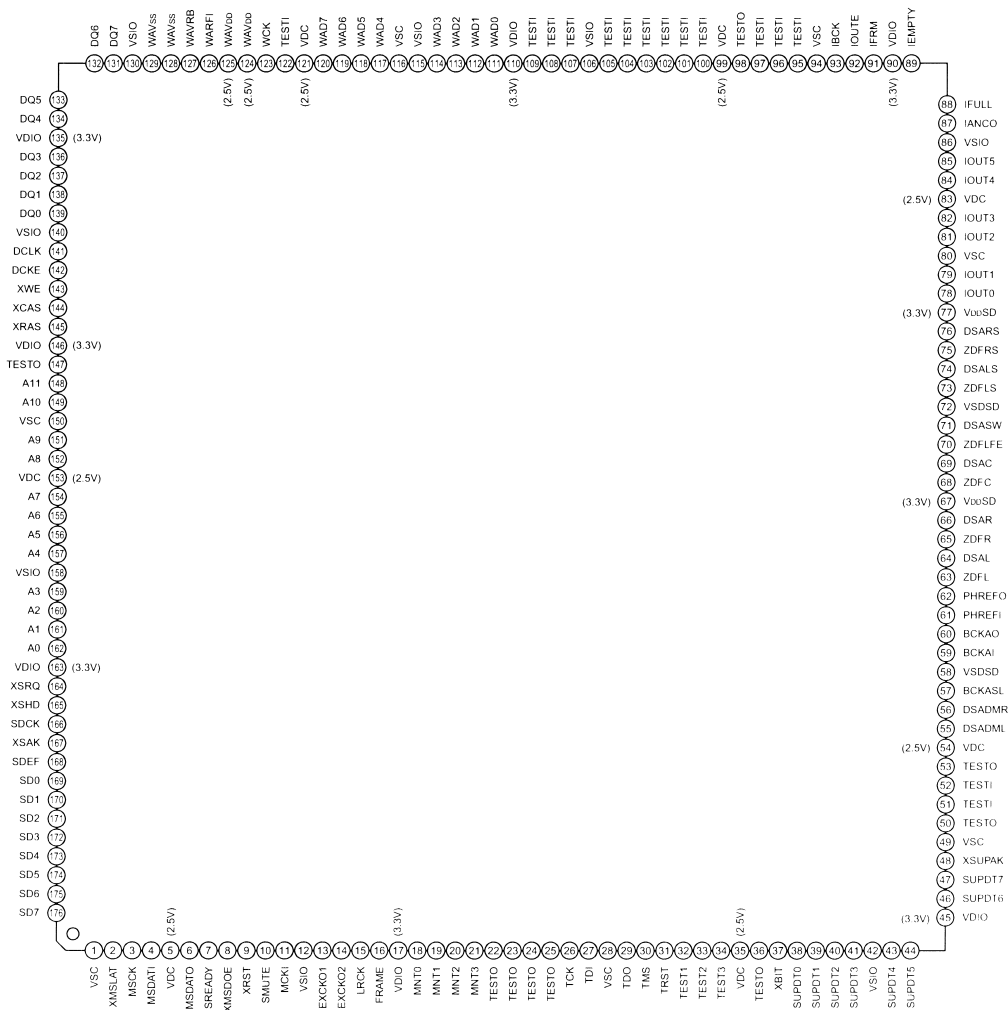

Blocks

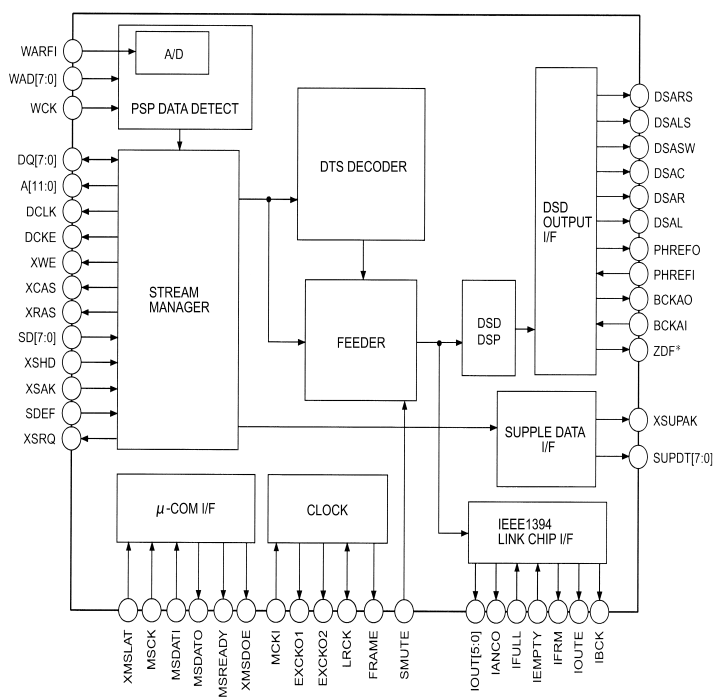

Terminal Functions

	Pin Name	I/O	Functions
1	VSC		It fixed to ground.(for Core)
2	XMSLAT	I	Latch input for μ COM serial communication.
3	MSCK	I	Shift clock input for μ COM serial communication.
4	MSDATAI	I	Data input for μ COM serial communication.
5	VDC		+2.5V Power for Core.
6	MSDATAO	O	Data output for μ COM serial communication. "Hi Z" potential except the output mode.
7	MSREADY	O	Completion flag of output preparation for μ COM serial communication. "L" is outputted at the time of completion.
8	XMSDOE	O	Output enable pin for μ COM serial communication. "L" is outputted at the time of MSDATO mode.
9	XRST	I	Reset pin. The whole IC is reset by at the time of "H" potential.
10	SMUTE	lpd	Soft Mute. Soft mute of the audio output is carried out at the time of "H" potential. It releases at the time of "L" potential.
11	MCKI	I	Master Clock input.
12	VSIO		It fixed to Ground. Ground for I/O.
13	EXCKO1	O	External output Clock 1.
14	EXCKO2	O	External output Clock 2.
15	LRCK	O	44.1kHz, IFs Clock output.
16	FRAME	O	Frame signal output.
17	VDIO		+3.3V Power for I/O.
18	MNT0	O	Monitor output.
19	MNT1	O	Monitor output.
20	MNT2	O	Monitor output.
21	MNT3	O	Monitor output.
22	TESTO	O	Output terminal for a Test. (open)
23	TESTO	O	Output terminal for a Test.(open)
24	TESTO	O	Output terminal for a Test.(open)
25	TESTO	O	Output terminal for a Test.(open)
26	TCK	I	Clock input for a Test. It fixed to "L" potential.
27	TDI	lpu	Input pin(pul loped) for a Test.(open)
28	VSC		It fixed to Ground. Ground for CORE.
29	TDO	O	Output for a Test.(open).
30	TMS	lpu	Input pin(pull up) for a Test.(open)
31	TRST	lpu	Reset pin(pull up) fo a Test. Input the Power on reset signal or fixed to "L" potential.
32	TEST1	O	Test input pin. It fixed to "L" potential.
33	TEST2	O	Test input pin. It fixed to "L" potential.
34	TEST3	O	Test input pin. It fixed to "L" potential.
35	VDC		+2.5V Power for CORE.
36	TESTO	O	Out put for TEST. It fixed to open.
37	XBIT	O	DST monitor.
38	SUPDT0	O	Supplementary data output. (LSB)
39	SUPDT1	O	Supplementary data output.
40	SUPDT2	O	Supplementary data output.
41	SUPDT3	O	Supplementary data output.
42	VSIO		Ground for I/O.
43	SUPDT4	O	Supplementary data output.
44	SUPDT5	O	Supplementary data output.
45	VDIO		Power for I/O.
46	SUPDT6	O	Supplementary data output.
47	SUPDT7	O	Supplementary data output. (MSB)
48	XSUPAK	O	Supplementary data Acknowledge output terminal.
49	VSC		Ground for CORE.

	Pin Name	I/O	Functions
50	TESTO	O	Output for TEST. (open)
51	TESTI	I	Input for TEST. It fixed to "L" potential.
52	TESTI	I	Input for TEST. It fixed to "L" potential.
53	TESTO	O	Output for TEST. (open)
54	VDC		+2.5V Power for CORE.
55	DSADML	O	DSD Data output terminal for Lch Down Mix.
56	DSADMR	O	DSD Data output terminal for Rch Down Mix.
57	BCKASL	I	I/O selection terminal of the Bit clock for DSD data output. L=input (Slave), H=output (Master)
58	VSDSD		Ground terminal for DSD data output.
59	BCKAI	O	Bit clock input terminal for DSD data output. Input a Bit clock into this terminal at the time of BCKASL= "L" potential.
60	BCKAO	O	Bit clock input terminal for DSD data output. Bit clock output from this terminal at the time of BCKASL= "H" potential.
61	PHREFI	I	Reference phase signal input terminal for DSD output phase modulation.
62	PHREFO	O	Reference phase signal output terminal for DSD output phase modulation.
63	ZDFL	O	Lch zero data detection flag (at the time of μ com setup). It will be set to "H" if non sound data continues 300 msecs.
64	DSAL	O	DSD data output terminal for Cch speaker.
65	ZDFR	O	Rch zero data detection flag (at the time of μ com setup). It will be set to "H" if non sound data continues 300 msecs.
66	DSAR	O	DSD data output terminal for Rch speaker.
67	VDDSD		+3.3V Power for DSD data output.
68	ZDFC	O	Cch zero data detection flag (at the time of μ com setup). It will be set to "H" if non sound data continues 300 msecs.
69	DSAC	O	DSD data output terminal for Cch speaker.
70	ZDFLFE	O	Lch zero data detection flag (at the time of μ com setup). It will be set to "H" if non sound data continues 300 msecs.
71	DSASW	O	DSD data output terminal for SWch speaker.
72	VSDSD		Ground for DSD data output.
73	ZDFLS	O	LSch zero data detection flag (at the time of μ com setup). It will be set to "H" if non sound data continues 300 msecs.
74	DSALS	O	DSD data output terminal for LSch speaker.
75	ZDFRS	O	RSch zero data detection flag (at the time of μ com setup). It will be set to "H" if non sound data continues 300 msecs.
76	DSARS	O	DSD data output terminal for RSch speaker.
77	VDDSD	O	+3.3V Power for DSD data output.
78	IOOUT0	O	Data output terminal 0 for IEEE1394 link chip I/F.
79	IOOUT1	O	Data output terminal 1 for IEEE1394 link chip I/F.
80	VSC		Ground for CORE.
81	IOOUT2	O	Data output terminal 2 for IEEE1394 link chip I/F.
82	IOOUT3	O	Data output terminal 3 for IEEE1394 link chip I/F.
83	VDC		+2.5V Power for CORE.
84	IOOUT4	O	Data output terminal 4 for IEEE1394 link chip I/F.
85	IOOUT5	O	Data output terminal 5 for IEEE1394 link chip I/F.
86	VSIO		Ground for I/O.
87	IANCO	O	Data output terminal 0 for IEEE1394 link chip I/F.
88	IFULL	I	Data output terminal 0 for IEEE1394 link chip I/F.
89	IEMPTY	I	Data output terminal 0 for IEEE1394 link chip I/F.
90	VDIO		+3.3V Power for I/O.
91	IFRM	O	Data output terminal 0 for IEEE1394 link chip I/F.
92	IOUTE	O	Data output terminal 0 for IEEE1394 link chip I/F.
93	IBCK	O	Data output terminal 0 for IEEE1394 link chip I/F.
94	VSC		Ground for CORE.
95	TESTI	I	TEST input terminal. It fixed to "H" potential.

	Pin Name	I/O	Functions
96	TESTI	I	TEST input terminal. It fixed to "L" potential.
97	TESTI	Ipu	TEST input terminal. It fixed to "H" potential.
98	TESTO	O	TEST output terminal. (open)
99	VDC		+2.5V Power for CORE.
100	TESTI	I	TEST input terminal. It fixed to "L" potential.
101	TESTI	I	TEST input terminal. It fixed to "L" potential.
102	TESTI	I	TEST input terminal. It fixed to "L" potential.
103	TESTI	I	TEST input terminal. It fixed to "L" potential.
104	TESTI	I	TEST input terminal. It fixed to "L" potential.
105	TESTI	I	TEST input terminal. It fixed to "L" potential.
106	VSIO		Ground for I/O.
107	TESTI	I	TEST input terminal. It fixed to "L" potential.
108	TESTI	I	TEST input terminal. It fixed to "L" potential.
109	TESTI	I	TEST input terminal. It fixed to "L" potential.
110	VDIO		+3.3V Power for I/O.
111	WAD0	I	External A/D data input terminal(LSB) for PSP physical disc mark detection.
112	WAD1	I	External A/D data input terminal for PSP physical disc mark detection.
113	WAD2	I	External A/D data input terminal for PSP physical disc mark detection.
114	WAD3	I	External A/D data input terminal for PSP physical disc mark detection.
115	VSIO		Ground for I/O.
116	VSC		Ground for CORE.
117	WAD4	I	External A/D data input terminal for PSP physical disc mark detection.
118	WAD5	I	External A/D data input terminal for PSP physical disc mark detection.
119	WAD6	I	External A/D data input terminal for PSP physical disc mark detection.
120	WAD7	I	External A/D data input terminal(MSB) for PSP physical disc mark detection.
121	VDC		+2.5V Power for CORE.
122	TESTI	I	TEST input terminal. It fixed to "L" potential.
123	WCK	I	Operation clock for PSP physical disc mark detection.
124	WAVDD		+2.5V Power. A/D Power supply for PSP physical disc mark detection.
125	WAVDD		+2.5V Power. A/D Power supply for PSP physical disc mark detection.
126	WARFI	Ai	Analog RF signal input terminal for PSP physical disc mark detection.
127	WAVRB	Ai	A/D bottom reference terminal for PSP physical disc mark detection.
128	WAVSS		A/D Ground terminal for PSP physical disc mark detection.
129	WSIO		A/D Ground terminal for PSP physical disc mark detection.
130	VSIO		Ground for I/O.
131	DQ7	I/O	SDRAM data input/output terminal. (MSB)
132	DQ6	I/O	SDRAM data input/output terminal.
133	DQ5	I/O	SDRAM data input/output terminal.
134	DQ4	I/O	SDRAM data input/output terminal.
135	VDIO		+3.3V Power for I/O.
136	DQ3	I/O	SDRAM data input/output terminal.
137	DQ2	I/O	SDRAM data input/output terminal.
138	DQ1	I/O	SDRAM data input/output terminal.
139	DQ0	I/O	SDRAM data input/output terminal. (LSB)
140	VSIO		Ground for I/O.
141	DCLK	O	Clock output terminal for SDRAM.
142	DCKE	O	Clock enable output terminal for SDRAM.
143	XWE	O	Write enable output terminal for SDRAM.
144	XCAS	O	Column address strobe output terminal for SDRAM.
145	XRAS	O	Row address strobe output terminal for SDRAM.
146	VDIO		+3.3V Power for I/O.
147	TESTO	O	Output terminal for TEST. (open)

	Pin Name	I/O	Functions
148	A11	O	Address output terminal for SDRAM. (MSB)
149	A10	O	Address output terminal for SDRAM.
150	VSC		Ground for CORE.
151	A9	O	Address output terminal for SDRAM.
152	A8	O	Address output terminal for SDRAM.
153	VDC		+2.5V Power for CORE.
154	A7	O	Address output terminal for SDRAM.
155	A6	O	Address output terminal for SDRAM.
156	A5	O	Address output terminal for SDRAM.
157	A4	O	Address output terminal for SDRAM.
158	VSIO		Ground for I/O.
159	A3	O	Address output terminal for SDRAM.
160	A2	O	Address output terminal for SDRAM.
161	A1	O	Address output terminal for SDRAM.
162	A0	O	Address output terminal for SDRAM. (LSB)
163	VDIO		+3.3V Power for I/O.
164	XSRQ	O	Output terminal of the Data Request signal inputted a front end processor.
165	XSHD	I	Input terminal of the header Flag outputted from a front end processor.
166	SDCK	I	Input terminal of the data conveyance Clock outputted from a front end processor.
167	XASK	I	Input terminal of the data valid Flag outputted from a front end processor.
168	SDEF	I	Input terminal of the error Flag outputted from a front end processor.
169	SD0	I	Input terminal of the stream Data outputted from a front end processor.
170	SD1	I	Input terminal of the stream Data outputted from a front end processor.
171	SD2	I	Input terminal of the stream Data outputted from a front end processor.
172	SD3	I	Input terminal of the stream Data outputted from a front end processor.
173	SD4	I	Input terminal of the stream Data outputted from a front end processor.
174	SD5	I	Input terminal of the stream Data outputted from a front end processor.
175	SD6	I	Input terminal of the stream Data outputted from a front end processor.
176	SD7	I	Input terminal of the stream Data outputted from a front end processor.

Ipu: Pull up input Ipd: Pull down input Ai: Analog input

M32102S6FP (MA: IC102)

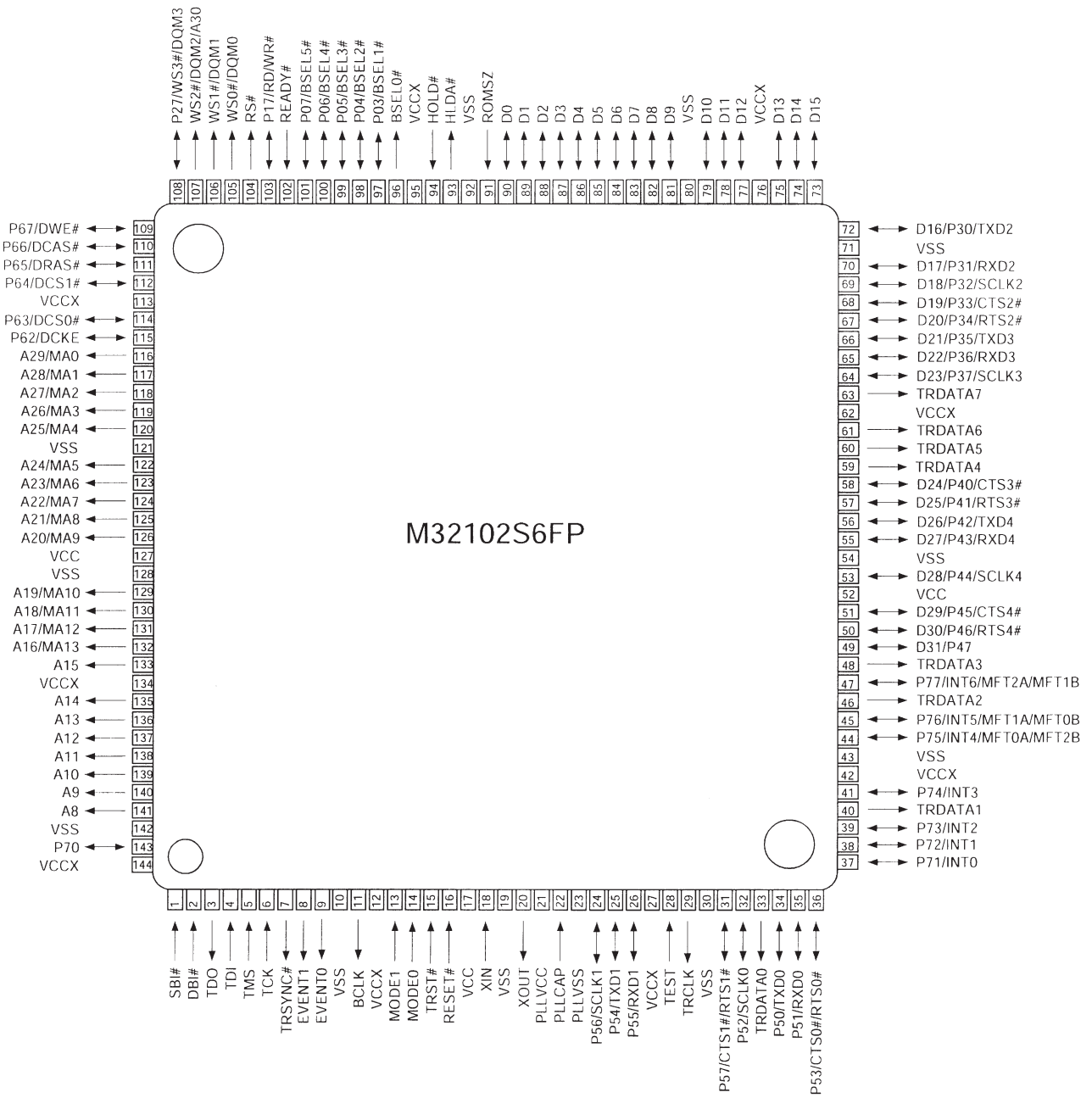

64M SDRAM (VI: IC401)

W986432AH

Vcc	1	86	Vss
DQ0	2	85	DQ15
VccQ	3	84	VccQ
DQ1	4	83	DQ14
DQ2	5	82	DQ13
VssQ	6	81	VccQ
DQ3	7	80	DQ12
DQ4	8	79	DQ11
VccQ	9	78	VssQ
DQ5	10	77	DQ10
DQ6	11	76	DQ9
VssQ	12	75	VccQ
DQ7	13	74	DQ8
NC	14	73	NC
Vcc	15	72	Vss
DQM0	16	71	DQM1
WE	17	70	NC
CAS	18	69	NC
RAS	19	68	CLK
CS	20	67	CKE
NC	21	66	A9
BS0	22	65	A8
BS1	23	64	A7
A10/AP	24	63	A6
A0	25	62	A5
A1	26	61	A4
A2	27	60	A3
DQM2	28	59	DQM3
Vcc	29	58	Vss
NC	30	57	NC
DQ16	31	56	DQ31
VssQ	32	55	VccQ
DQ17	33	54	DQ30
DQ18	34	53	DQ29
VccQ	35	52	VssQ
DQ19	36	51	DQ28
DQ20	37	50	DQ27
VssQ	38	49	VccQ
DQ21	39	48	DQ26
DQ22	40	47	DQ25
VccQ	41	46	VssQ
DQ23	42	45	DQ24
Vcc	43	44	Vss

W986432AH Terminal Function

Pin No.	Pin Name	Function
25~27, 60~66, 24	A0-A10	Address for row and column
22, 23	BS0, BS1	Bank Select to activate during row address latch time
2, 4, 5, 7, 8, 10, 11, 13, 31, 33, 34, 36, 37, 39, 40, 42, 45, 47, 48, 50, 51, 53, 54, 56, 74, 76, 77, 79, 80, 82, 83, 85	DQ0-DQ31	Data Input / Output pins for data
20	CS	Chip Select to disable or enable the command decoder
19	RAS	Row Address Strobe
18	CAS	Column Address Strobe
17	WE	Write Enable
16, 28, 59, 71	DQM0-DQM3	Input / Output Mask
68	CLK	Clock Inputs
67	CKE	Clock Enable
1, 15, 29, 43	Vcc	Power (+3.3V)
44, 58, 72, 86	Vss	Ground
3, 9, 35, 41, 49, 55, 75, 81	VccQ	Power (+3.3V) for I/O Buffer
6, 12, 32, 38, 46, 52, 78, 84	VssQ	Ground for I/O Buffer
14, 21, 30, 57, 69, 70, 73	NC	No Connection

M66005AFP (AU: IC101)

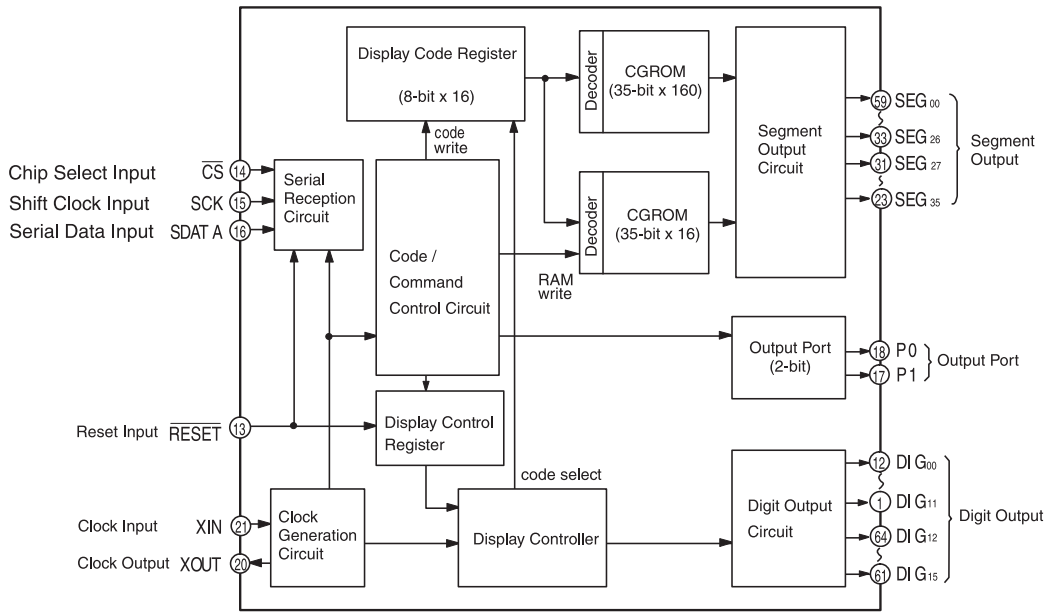
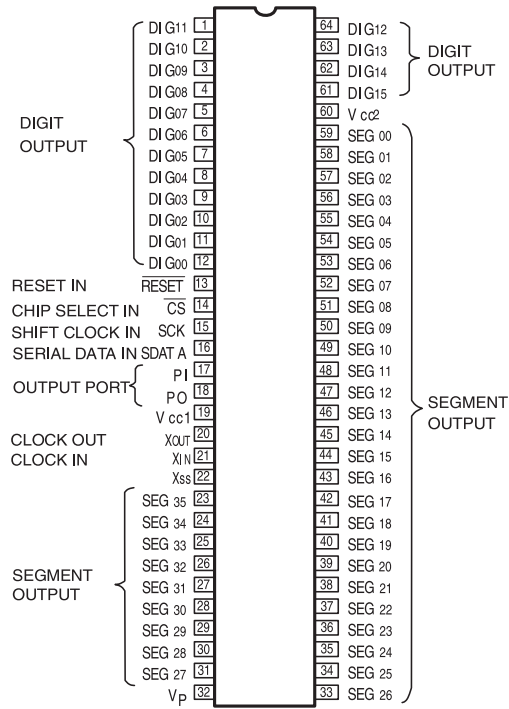

ADV7190 (VI: IC705) For Europe model

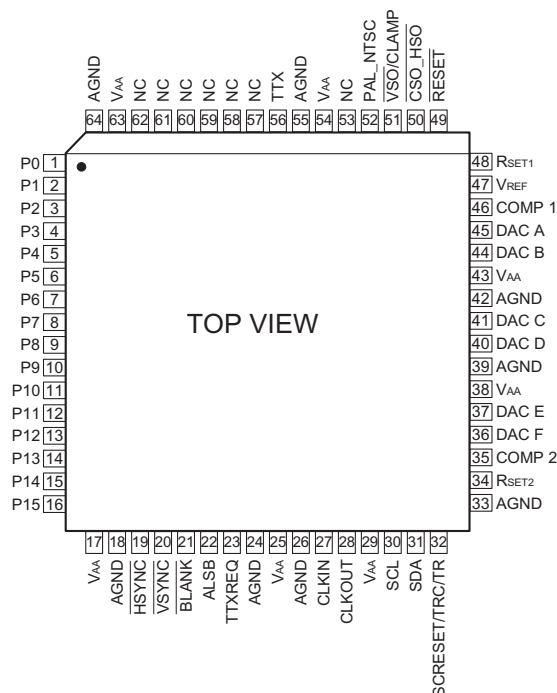

ADV7190 Terminal Function

Pin No.	Pin Name	I/O	Function
1~16	P0-P15	I	8-Bit or 16-Bit 4:2:2 Multiplexed YCrCb Pixel Port. The LSB of the input data is set up on Pin P0.
17, 25, 29, 38, 43, 54, 63	VAA	P	Analog Power Supply (3.3V to 5V).
18, 24, 26, 33, 39, 42, 55, 64	AGND	G	Analog Ground.
19	HSYNC	I/O	HSYNC (Modes 1, 2, and 3) Control Signal. This pin may be configured to be an output (Master Mode) or an input (Slave Mode) and accept Sync Signals.
20	VSYNC	I/O	VSYNC Control Signal. This pin may be configured as an output (Master Mode) or as an input (Slave Mode) and accept VSYNC as a Control Signal.
21	BLANK	I/O	Video Blanking Control Signal. This signal is optional. For further information see Vertical Blanking Data Insertion and BLANK Input section.
22	ALSB	I	TTL Address Input. This signal sets up the LSB of the MPU address.
23	TTXREQ	O	Teletext Data Request Output Signal, used to control teletext data transfer.
27	CLKIN	I	TTL Clock Input. Requires a stable 27 MHz reference clock for standard operation. Alternatively, a 24.5454 MHz (NTSC) or 29.5 MHz (PAL) can be used for square pixel operation.
28	CLKOUT	O	Clock Output Pin.
30	SCL	I	MPU Port Serial Interface Clock Input.
31	SDA	I/O	MPU Port Serial Data Input/Output.
32	SCRESET/RTC/TR	I	Multifunctional Input: Real-Time Control (RTC) Input, Timing Reset Input, Subcarrier Reset Input.
34	RSET2	I	A 1200 ohm resistor connected from this pin to ground is used to control full-scale amplitudes of the Video Signals from DACs D, E, and F.
35	COMP 2	O	Compensation Pin for DACs D, E, and F. Connect a 0.1 μF Capacitor from COMP2 toVAA.
36	DAC F	O	S-Video C/V/RED Analog Output. This DAC is capable of providing 4.33 mA output.
37	DAC E	O	S-Video Y/U/BLUE Analog Output. This DAC is capable of providing 4.33 mA output.
40	DAC D	O	Composite/Y/GREEN Analog Output. This DAC is capable of providing 4.33 mA output.
41	DAC C	O	S-Video C/V/RED Analog Output. This DAC is capable of providing 4.33 mA output.
44	DAC B	O	S-Video Y/U/BLUE Analog Output. This DAC is capable of providing 4.33 mA output.
45	DAC A	O	Composite/Y/GREEN Analog Output. This DAC is capable of providing 4.33 mA output.
46	COMP 1	O	Compensation Pin for DACs A, B, and C. Connect a 0.1 μF Capacitor from COMP1 toVAA.
47	VREF	I/O	Voltage Reference Input for DACs or Voltage Reference Output (1.235V). An external VREF cannot be used in 4x oversampling mode.
48	RSET1	I	A 1200 ohm resistor connected from this pin to ground is used to control full-scale amplitudes of the Video Signals from DACs A, B, and C.
49	RESET	I	The input resets the on-chip timing generator and sets the ADV7190/ADV7191 into default mode. See Appendix 8 for Default Register Settings.
50	CSO_HSO	O	Dual function CSO or HSO Output Sync Signal at TTL Level.
51	VSO/CLAMP	I/O	Multifunction Pin. VSO Output Sync Signal at TTL level. CLAMP TTL Output Signals can be used to drive external circuitry to enable clamping of all Video Signals.
52	PAL_NTSC	I	Input signal to select PAL or NTSC mode of operation, pin set to Logic 1 selects PAL.
53, 57~62	NC		No Connect.
56	TTX	I	Teletext Data Input Pin.

ADV7300 (VI:IC704)

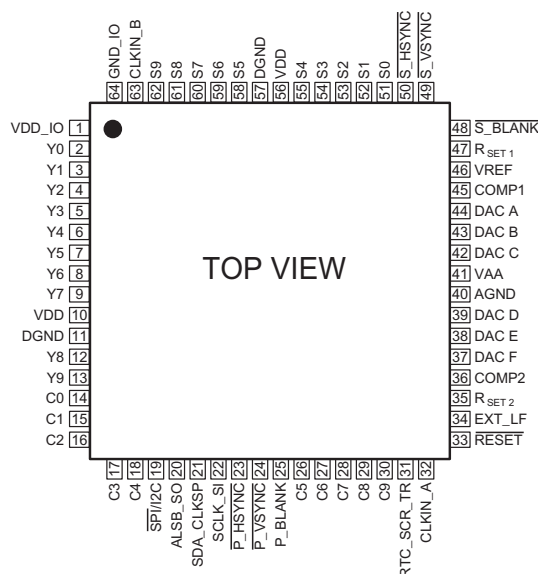

ADV7300 Terminal Function

Pin No.	Pin Name	I/O	Function
1	VDD_IO	P	Digital power supply.
2~9, 12, 13	Y9-0	I	10-Bit Progressive scan/ HDTV input port for Y data.
10, 56	VDD	P	Digital power supply.
11, 57	DGND	G	Digital Ground
14~18, 26~30	C9-0	I	10-Bit Progressive scan/ HDTV input port for CrCb color data in 4:2:2 input mode.
19	$\overline{\text{S}}\text{PI}/\text{I}2\text{C}$	I	When this input pin is brought low, the ADV7300 interfaces over the SPI port and uses this input as part of the 4 wire SPI interface. When this input pin is tied high [VDD_IO], the ADV7300 interfaces over the I2C port.
20	ALSB_SO	I/O	Multifunctional pin.
21	SDA_CLKSP	I/O	Multifunctional pin.
22	SCLK_SI	I	Multifunctional input.
23	$\overline{\text{P}}_{\text{HSYNC}}$	I	Video Horizontal Sync Control Signal for HD sync in simultaneous SD/HD mode and HD only mode.
24	$\overline{\text{P}}_{\text{VSYNC}}$	I	Video Vertical Sync Control Signal for HD sync in simultaneous SD/HD mode and HD only mode.
25	P_BLANK	I	Video Blanking Control Signal for HD sync in simultaneous SD/HD mode and HD only mode.
31	RTC_SCR_TR	I	Multifunctional input.
32	CLKIN_A	I	Pixel Clock Input for HD only or SD only modes.
33	$\overline{\text{R}}\text{ESET}$	I	This input resets the on-chip timing generator and sets the ADV7300 into Default Register setting. Reset is an active low signal.
34	EXT_LF	I	External Loop filter for the internal PLL.
35, 47	RSET1,2	I	A1520 Ohms resistor must be connected from this pin to AGND and is used to control the amplitudes of the DAC outputs.
36,45	COMP	O	Compensation Pin for DACs.
37	DAC F	O	In SD only mode: Chroma/RED/V analog output. In HD only mode and simultaneous HD/SD: Pb/ BLUE (HD) analog output.
38	DAC E	O	In SD only mode: Luma/BLUE/U analog output. In HD only mode and simultaneous HD/SD: Pr/ RED (HD) analog output.
39	DAC D	O	In SD only mode: CVBS/GREEN/Y analog output. In HD only mode and simultaneous HD/SD: Y/ GREEN (HD) analog output.
40	AGND	G	Analog Ground
41	VAA	P	Analog power supply.
42	DAC C	O	Chroma/ RED/ V SD analog output.
43	DAC B	O	Luma/ BLUE/ U SD analog output.
44	DAC A	O	CVBS/ GREEN/ Y SD analog output.
46	VREF	I/O	Optional External Voltage Reference Input for DACs or Voltage Reference Output (1.235V).
48	$\overline{\text{S}}_{\text{BLANK}}$	I/O	Video Blanking Control Signal for SD.
49	$\overline{\text{S}}_{\text{VSYNC}}$	I/O	Video Vertical Sync Control Signal for SD.
50	$\overline{\text{S}}_{\text{HSYNC}}$	I/O	Video Horizontal Control Signal for SD.
51~55, 58~62	S9-S0	I	10-Bit Standard Definition input port. Or Progressive Scan/ HDTV input port for Cr [Red/V] color data in 4:4:4 input mode.
63	CLKIN_B	I	Pixel Clock Input.
64	GND_IO	G	Digital Ground

CXD1881AR (MA: IC501)

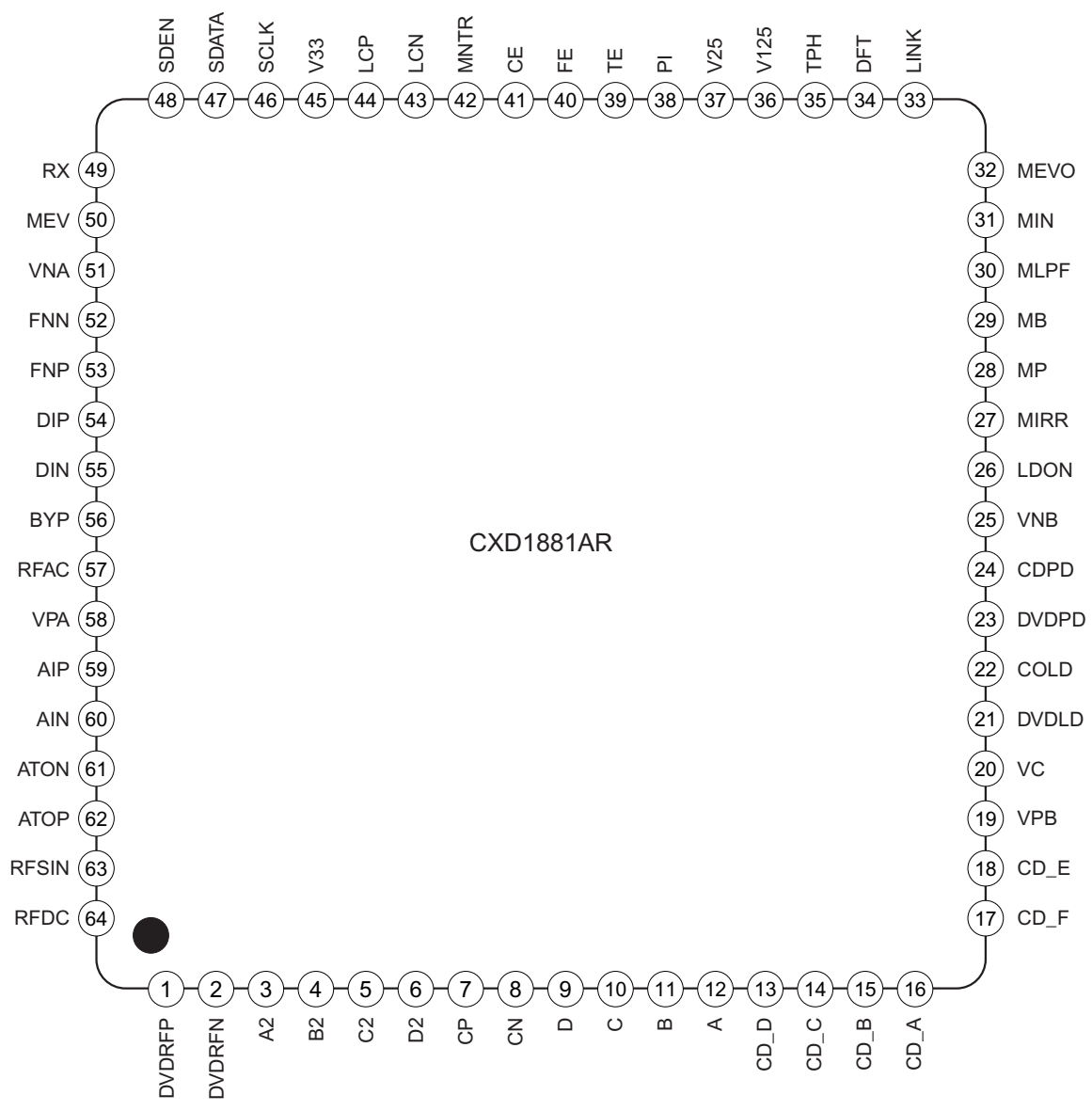

Block Diagram

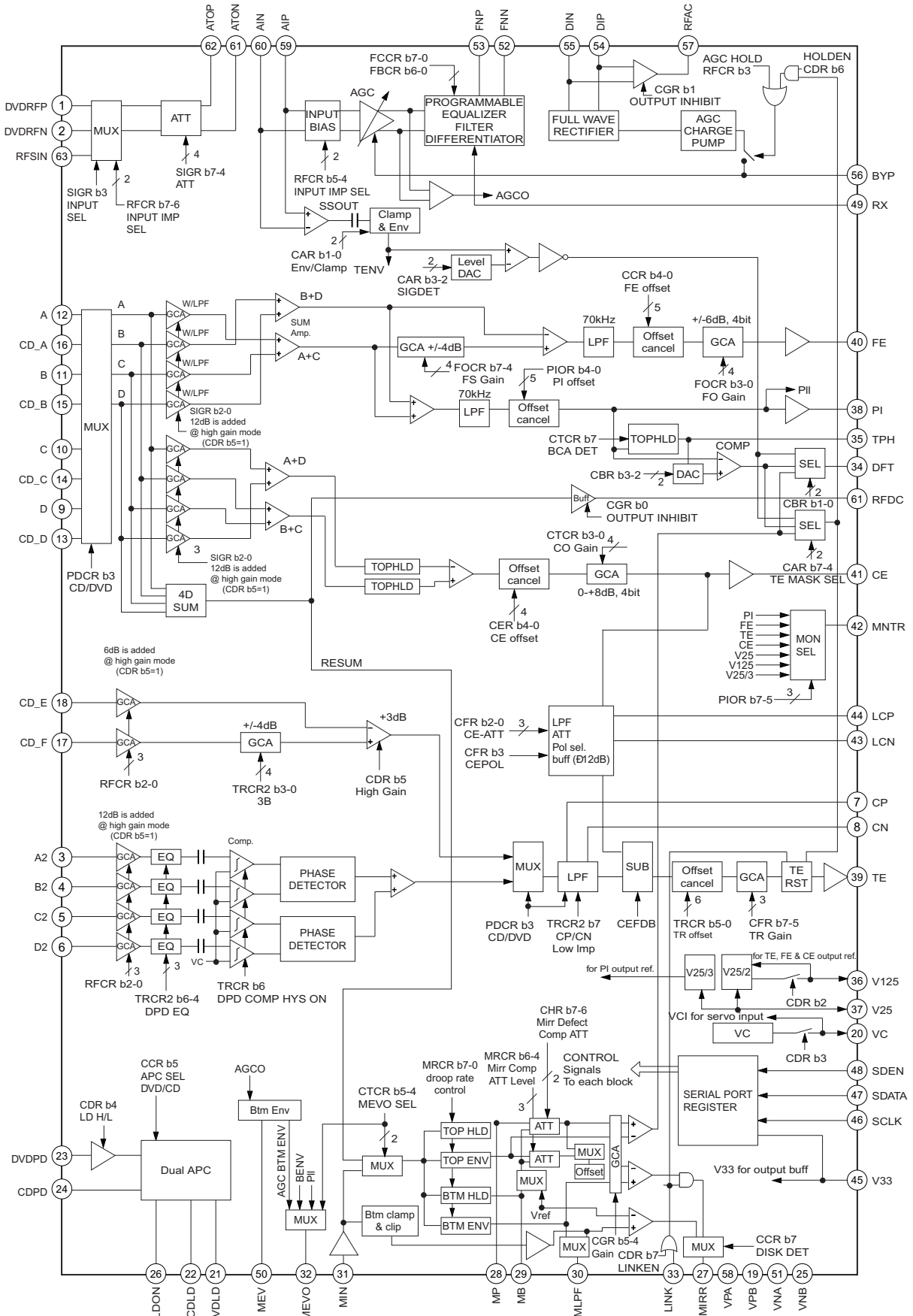

Terminal Function

Power Supply Pins

Name	I/O	Function
VPA		Power for RF and serial port
VPB		Power for servo
VNA		GND for RF and serial port
VNB		GND for servo
V33		Power for output buffer
V25		Reference Power for servo output

Input Pins

Name	I/O	Function
DVDRFP,DVDRFN	I	RF signal input
RFSIN	I	RF signal input
AIP,AIN	I	AGC amp. input
DIP,DIN	I	Analog input for RF single buffer
A,B,C,D	I	Photo detector interface input
A2,B2,C2,D2	I	Photo detector interface input
CD A,B,C,D	I	CD photo detector interface input
CD E,F	I	CD photo detector interface input
MIN	I	RF signal input for mirror
DVDPD	I	APC input
CDPD	I	APC input
LDON	I	APC input ON/OFF (L:Open)
LINK	I	Link signal input (L:Open)
	O	Mirror monitor output

Output Pins

Name	I/O	Function
ATOP,ATON	O	Differential attenuator output
FNP,FNN	O	Differential normal output
RFAC	O	Single end normal output
RFDC	O	RF signal output
FE	O	Focus error signal output
TE	O	Tracking error signal output
CE	O	Center error signal output
MEVO	O	RFDDC bottom envelope output
DFT	O	Defect output
MIRR	O	Mirror detected output
PI	O	Pull in signal output
DVDLD	O	APC output
CDLD	O	APC output
MNTR	O	Monitor output

Analog Pins

Name	I/O	Function
BYP		RF AGC integration capacitor connecting terminal
CP		Differential phase tracking LPF terminal
CN		Differential phase tracking LPF terminal
LCP		Lens shift offset cancel LPF terminal
LCN		Lens shift offset cancel LPF terminal
MP		MIRR top hold terminal
MB		MIRR bottom hold terminal
MEV		RFDC bottom envelope terminal
MLPF		Mirror LPF terminal
TPH		PI top hold terminal
VC		Reference voltage output
V125		Reference voltage output
RX		Reference resistor input

Serial Port Pins

Name	I/O	Function
SDEN	I	Serial data enable
SDATA	I/O	Serial data
SCLK	I	Serial clock

W986416DH (MA: IC104)

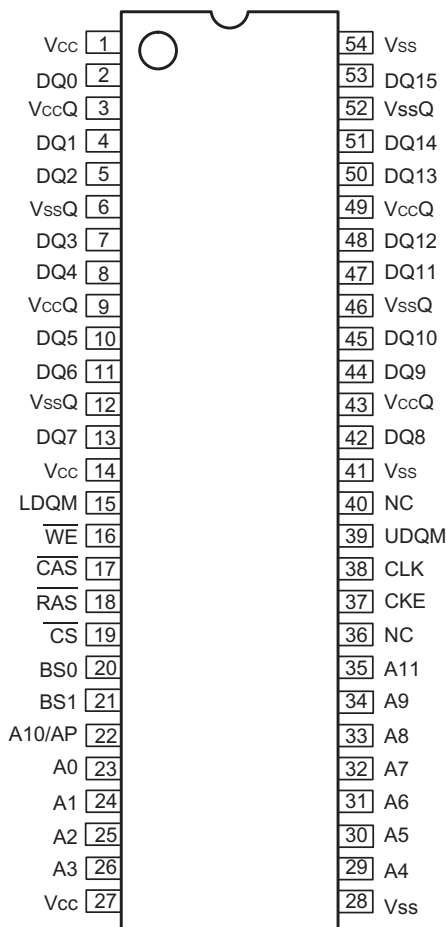

W986416DH Terminal Function

Pin No.	Pin Name	Function	Description
1, 14, 27	Vcc	Power (+3.3V)	Power for input buffers and logic circuit inside DRAM.
2, 4, 5, 7, 8, 10, 11, 13, 42, 44, 45, 47, 48, 50, 51, 53	DQ0-DQ15	Data Input/Output	Multiplexed pins for data output and input.
3, 9, 43, 49	VccQ	Power (+3.3V) for I/O buffer	Separated power from VCC, to improve DQ noise immunity.
6, 12, 46, 52	VssQ	Ground for I/O buffer	Separated ground from VSS, to improve DQ noise immunity.
16	WE	Write Enable	Referred to RAS.
17	CAS	Column Address Strobe	Referred to RAS.
18	RAS	Row Address Strobe	Command input. When sampled at the rising edge of the clock RAS, CAS and WE define the operation to be executed.
19	CS	Chip Select	Disable or enable the command decoder. When command decoder is disabled, new command is ignored and previous operation continues.
20, 21	BS0, BS1	Bank Select	Select bank to activate during row address latch time, or bank to read/write during address latch time.
23~26, 22, 29~35	A0-A11	Address	Multiplexed pins for row and column address. Row address: A0-A11. Column address: A0-A7. A10 is sampled during a precharge command to determine if all banks are to be precharged or bank selected by BS0, BS1.
28, 41, 54	Vss	Ground	Ground for input buffers and logic circuit inside DRAM.
36, 40	NC	No Connection	No Connection
37	CKE	Clock Enable	CKE controls the clock activation and deactivation. When CKE is low, Power Down mode, Suspend mode, or Self Refresh mode is entered.
38	CLK	Clock Inputs	System clock used to sample inputs on the rising edge of clock.
39, 15	UDQM, LDQM	Input/Output mask	The output buffer is placed at Hi-Z (with latency of 2) when DQM is sampled high in read cycle. In write cycle, sampling DQM high will block the write operation with zero latency.

16M SDRAM (TOSP)-8 (MA: IC402)

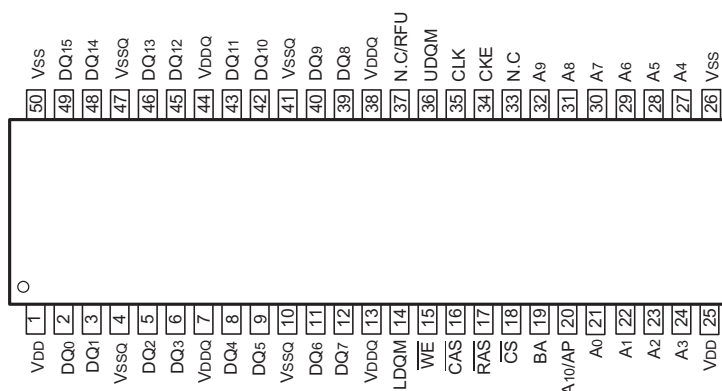

Terminal Function

Pin No.	Pin Name	Symbol	Function
1	V _{DD}	Power Supply/Ground	Power and ground for the input buffer and the core logic
2	DQ ₀	Data Input/Output	Data input/output are multiplexed on the same pin
3	DQ ₁	Data Input/Output	Data input/output are multiplexed on the same pin
4	V _{SSQ}	Data Output Power/Ground	Isolated power supply and ground for the output buffer
5	DQ ₂	Data Input/Output	Data input/output are multiplexed on the same pin
6	DQ ₃	Data Input/Output	Data input/output are multiplexed on the same pin
7	V _{DDQ}	Data Output Power/Ground	Isolated power supply and ground for the output buffer
8	DQ ₄	Data Input/Output	Data input/output are multiplexed on the same pin
9	DQ ₅	Data Input/Output	Data input/output are multiplexed on the same pin
10	V _{SSQ}	Data Output Power/Ground	Isolated power supply and ground for the output buffer
11	DQ ₆	Data Input/Output	Data input/output are multiplexed on the same pin
12	DQ ₇	Data Input/Output	Data input/output are multiplexed on the same pin
13	V _{DDQ}	Data Output Power/Ground	Isolated power supply and ground for the output buffer
14	L DQM	Data Input/Output Mask	Blocks data input when active
15	WE	Write Enable	Enables write operation and row precharge
16	CAS	Column Address Strobe	Latches column address on the positive going edge of the CLK at low
17	RAS	Row Address Strobe	Latches row address on the positive going edge of the CLK at low
18	CS	Chip Select	Disables or enables device operation by masking or enabling all inputs except CLK, CKE, and LDQM
19	BA	Bank Select Address	Selects bank to be activated during row address latch time
20	A _{10/AP}	Address	Row/column addresses are multiplexed on the same pin
21	A ₀	Address	Row/column addresses are multiplexed on the same pin
22	A ₁	Address	Row/column addresses are multiplexed on the same pin
23	A ₂	Address	Row/column addresses are multiplexed on the same pin
24	A ₃	Address	Row/column addresses are multiplexed on the same pin
25	V _{DD}	Power Supply/Ground	Power and ground for the input buffer and the core logic
26	V _{SS}	Power Supply/Ground	Power and ground for the input buffer and the core logic
27	A ₄	Address	Row/column addresses are multiplexed on the same pin
28	A ₅	Address	Row/column addresses are multiplexed on the same pin
29	A ₆	Address	Row/column addresses are multiplexed on the same pin
30	A ₇	Address	Row/column addresses are multiplexed on the same pin
31	A ₈	Address	Row/column addresses are multiplexed on the same pin
32	A ₉	Address	Row/column addresses are multiplexed on the same pin
33	N. C	No Connection	No connect pin
34	CKE	Clock Enable	Masks system clock to freeze operation from the next clock cycle
35	CLK	System Clock	Active on the positive going edge to sample all inputs
36	U DQM	Data Input/Output Mask	Blocks data input when active
37	N. C/RFU	NC/Reserved	No connect pin
38	V _{DDQ}	Data Output Power/Ground	Isolated power supply and ground for the output buffer
39	DQ ₈	Data Input/Output	Data input/output are multiplexed on the same pin
40	DQ ₉	Data Input/Output	Data input/output are multiplexed on the same pin
41	V _{SSQ}	Data Output Power/Ground	Isolated power supply and ground for the output buffer
42	DQ ₁₀	Data Input/Output	Data input/output are multiplexed on the same pin
43	DQ ₁₁	Data Input/Output	Data input/output are multiplexed on the same pin
44	V _{DDQ}	Data Output Power/Ground	Isolated power supply and ground for the output buffer
45	DQ ₁₂	Data Input/Output	Data input/output are multiplexed on the same pin
46	DQ ₁₃	Data Input/Output	Data input/output are multiplexed on the same pin
47	V _{SSQ}	Data Output Power/Ground	Isolated power supply and ground for the output buffer
48	DQ ₁₄	Data Input/Output	Data input/output are multiplexed on the same pin
49	DQ ₁₅	Data Input/Output	Data input/output are multiplexed on the same pin
50	V _{SS}	Power Supply/Ground	Power and ground for the input buffer and the core logic

FAN8042 (MA: IC508)

Pin Assignments

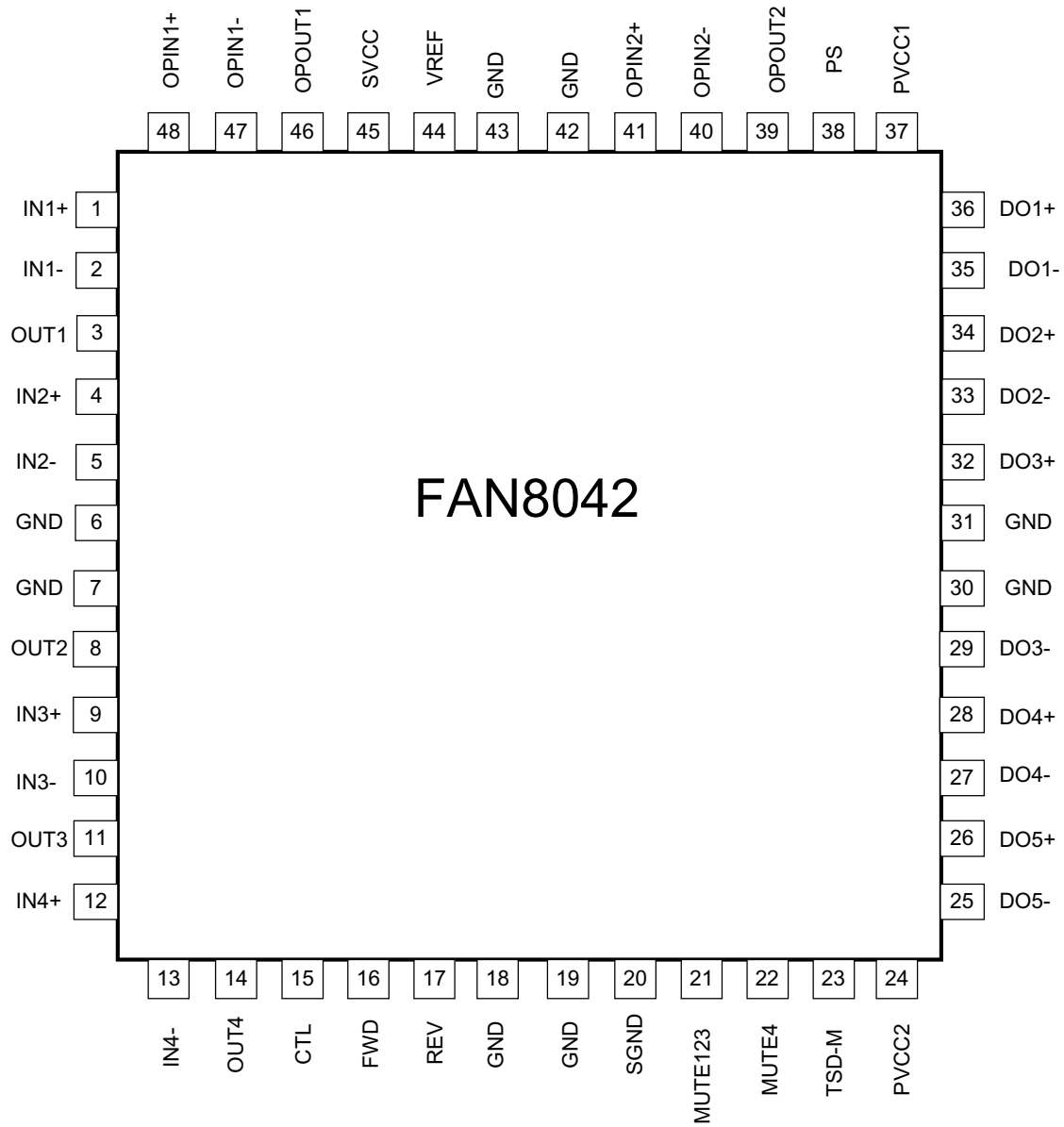

Pin Definitions

Pin Number	Pin Name	I/O	Pin Function Description
1	IN1	I	CH1 op-amp input ()
2	IN1	I	CH1 op-amp input ()
3	OUT1	O	CH1 op-amp output
4	IN2	I	CH2 op-amp input ()
5	IN2	I	CH2 op-amp input ()
6	GND	-	Ground
7	GND	-	Ground
8	OUT2	O	CH2 op-amp output
9	IN3+	I	CH3 op-amp input (+)
10	IN3	I	CH3 op-amp input ()
11	OUT3	O	CH3 op-amp output
12	IN4+	I	CH4 op-amp input (+)
13	IN4	I	CH4 op-amp input ()
14	OUT4	O	CH4 op-amp output
15	CTL	I	CH5 motor speed control
16	FWD	I	CH5 forward input
17	REV	I	CH5 reverse input
18	GND	-	Ground
19	GND	-	Ground
20	SGND	-	Signal Ground
21	MUTE123	I	Mute for CH1,2,3
22	MUTE4	I	Mute for CH4
23	TSD-M	O	TSD monitor
24	PVCC2	-	Power supply voltage 2 (For CH4, CH5)
25	DO5-	O	CH5 drive output (-)
26	DO5+	O	CH5 drive output (+)
27	DO4	O	CH4 drive output ()
28	DO4+	O	CH4 drive output (+)
29	DO3	O	CH3 drive output ()
30	GND	-	Ground
31	GND	-	Ground
32	DO3+	O	CH3 drive output (+)
33	DO2	O	CH2 drive output ()
34	DO2+	O	CH2 drive output (+)
35	DO1	O	CH1 drive output ()
36	DO1+	O	CH1 drive output (+)
37	PVCC1	-	Power supply voltage 1 (FOR CH1, CH2, CH3)
38	PS	I	Power save
39	OPOUT2	O	Normal op-amp2 output
40	OPIN2	I	Normal op-amp2 input ()
41	OPIN2+	I	Normal op-amp2 input (+)
42	GND	-	Ground
43	GND	-	Ground
44	VREF	I	Bias voltage input
45	SVCC	-	Signal & OPAMPs supply voltage
46	OPOUT1	O	Normal op-amp1 output
47	OPIN1	I	Normal op-amp1 input ()
48	OPIN1+	I	Normal op-amp1 input (+)

Internal Block Diagram

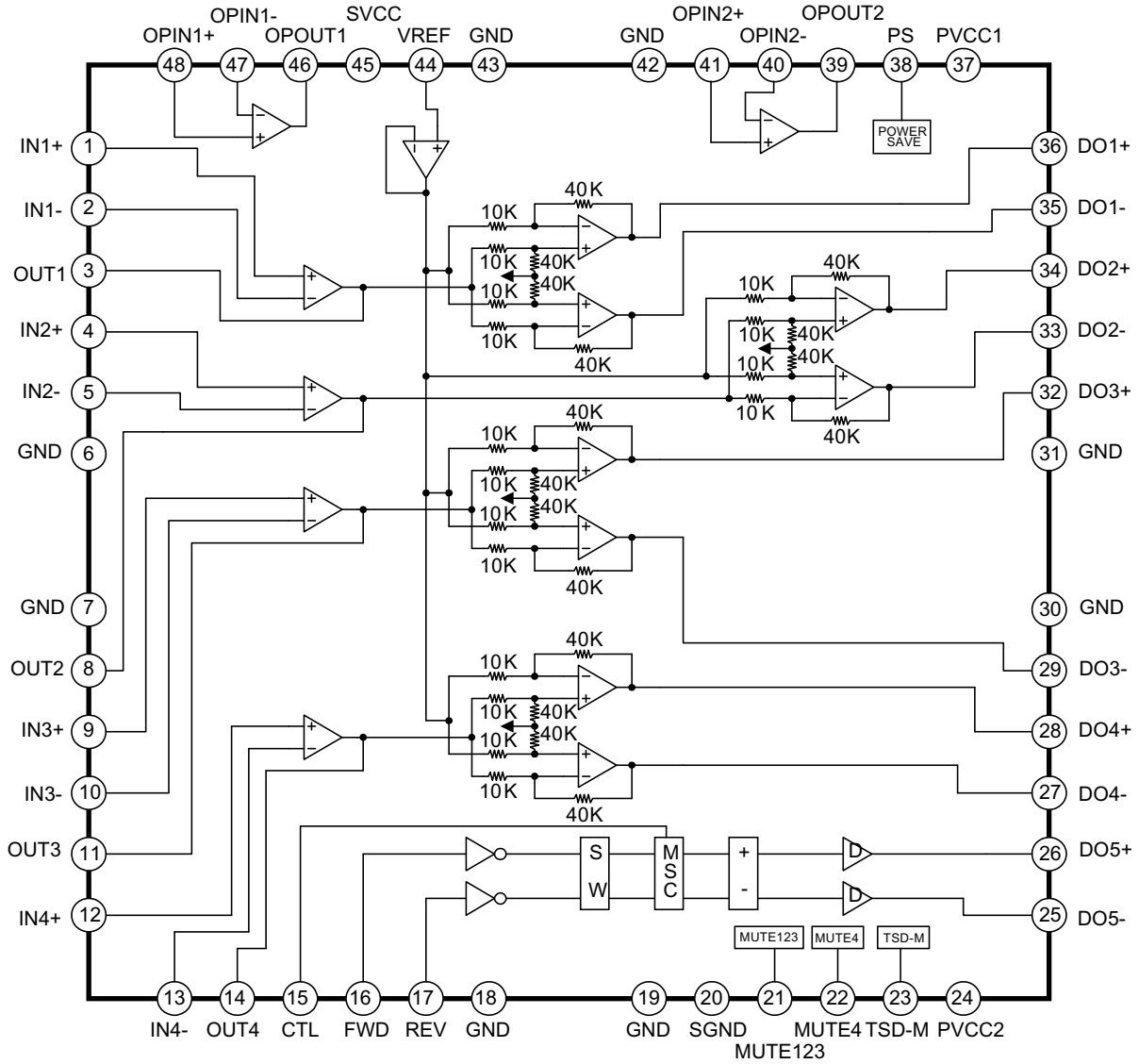

Note: Detailed circuit of the output power amp

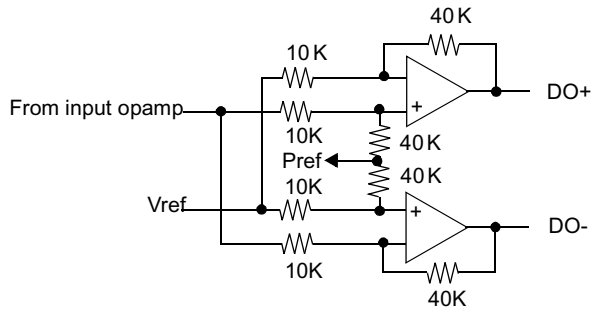

Pref1 is almost PVCC1 / 2
 Pref2 is almost PVCC2 / 2

MX29LV160ABTC-90 (MA: IC103)

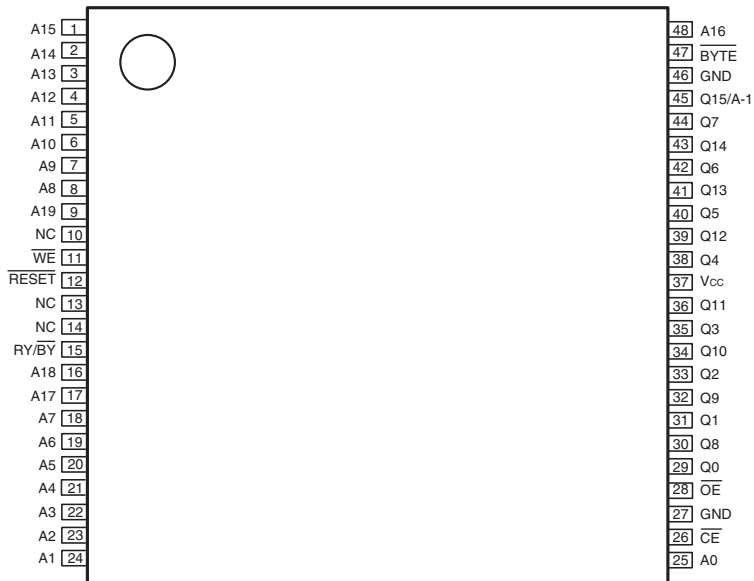

Pin Description

Symbol	Pin Name
A0~A19	Address Input
Q0~Q14	Data Input/Output
Q15/A-1	Q15 (Word mode)/LSB addr (Byte mode)
\overline{CE}	Chip Enable Input
\overline{WE}	Write Enable Input
\overline{BYTE}	Word/Byte Selection input
RESET	Hardware Reset Pin/Sector Protect Unlock
\overline{OE}	Output Enable Input
RY/BY	Ready/Busy Output
Vcc	Power Supply Pin (2.7V~3.6V)
GND	Ground Pin

AT49LV1025 (MA: IC302)

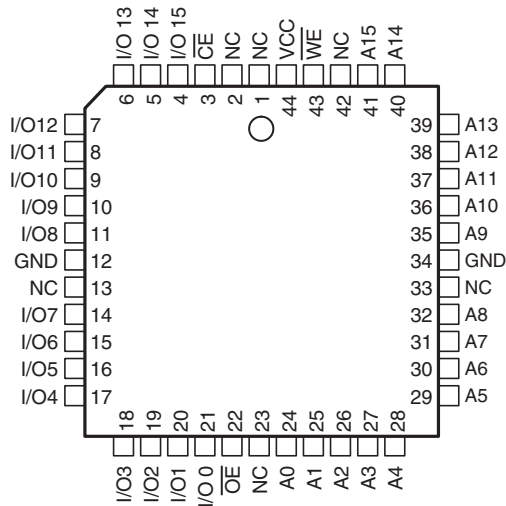

Terminal Function

Pin Name	Function
A0-A15	Address Inputs
\overline{CE}	Chip Enable
\overline{OE}	Output Enable
\overline{WE}	Write Enable
I/O0-I/O15	Data Inputs/Outputs
NC	No Connection

M11L16161SA (MA: IC503)

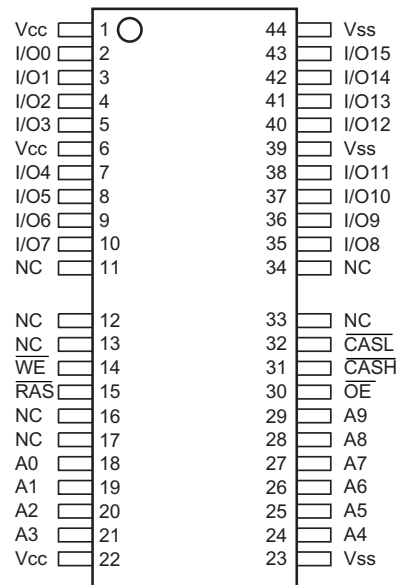

PIN DESCRIPTIONS

PIN NO.	PIN NAME	TYPE	DESCRIPTION
18~21,24~29	A0~A9	Input	Address Input Row Address:A0~A9 Column Address:A0~A9
15	$\overline{\text{RAS}}$	Input	Row Address Strobe
31	$\overline{\text{CASH}}$	Input	Column Address Strobe/Upper Byte Control
32	$\overline{\text{CASL}}$	Input	Column Address Strobe/Lower Byte Control
14	$\overline{\text{WE}}$	Input	Write Enable
30	$\overline{\text{OE}}$	Input	Output Enable
2~5,7~10, 35~38,40~43	I/O0~I/O15	Input/Output	Data Input/Output
1,6,22	Vcc	Supply	Power,(5V or 3.3V)
23,39,44	Vss	Ground	Ground
11,12,13,16, 17,33,34	NC	-	No Connect

AN8471SA (MA: IC505)

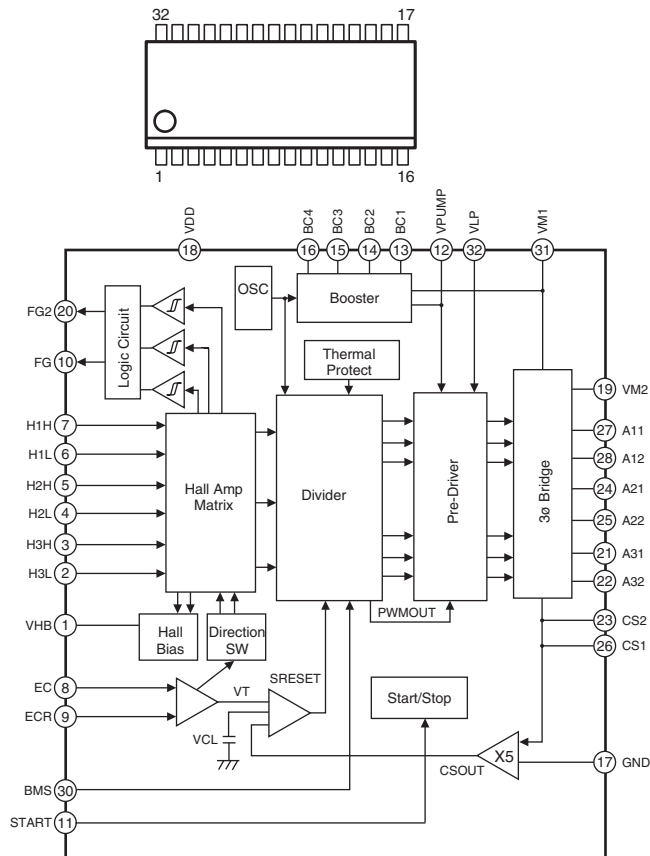

Pin No.	Pin Name	Function
1	VHB	Hall bias pin
2	H3L	Hall element 3 input (-)
3	H3H	Hall element 3 input (+)
4	H2L	Hall element 2 input (-)
5	H2H	Hall element 2 input (+)
6	H1L	Hall element 1 input (-)
7	H1H	Hall element 1 input (+)
8	EC	Torque command input pin
9	ECR	Torque command ref. input pin
10	FG1	FG signal lout put pin (0.C)
11	START	Start/Stop switching pin
12	VPUMP	Booster pin
13	BC1	Booster cap. connecting pin 1
14	BC2	Torque command input pin 2
15	BC3	Torque command input pin 3
16	BC4	Torque command input pin 4
17	GND	GND pin
18	V _{DD}	Power pin
19	VM2	Motor power pin 2
20	FG2	3x FG signal output pin (0.C)
21	A31	Drive output 3
22	A32	Drive output 3
23	CS2	Current detect pin 2
24	A21	Drive output 2
25	A22	Drive output 2
26	CS1	Current detect pin 1
27	A11	Drive output 1
28	A12	Drive output 1
29	NC	N.C.
30	BMS	Brake mode switching pin
31	VM1	Motor power pin 1
32	VLP	Pre-driver lower power

DSD1791DBR (AU: IC301, 302, 303)

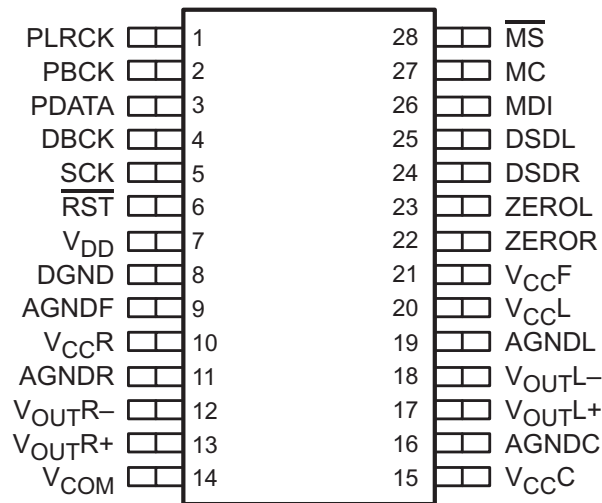

Block Diagram

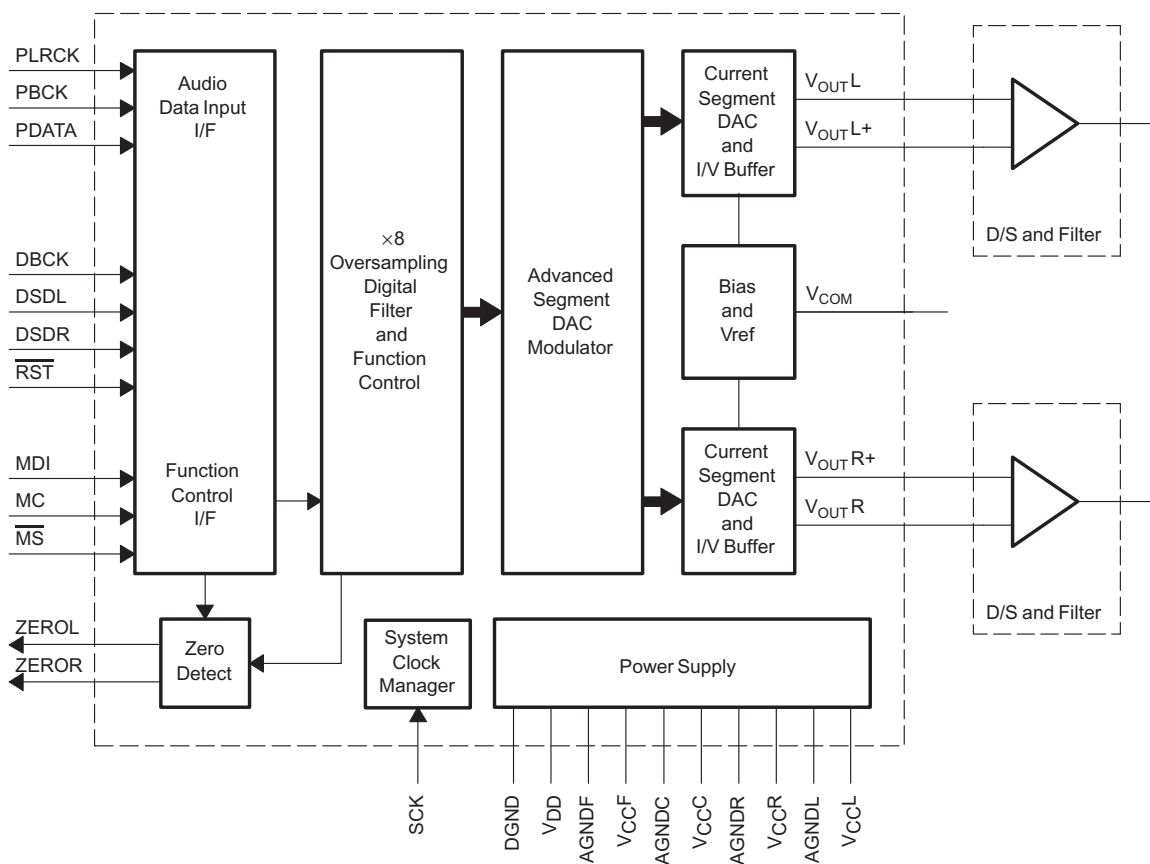

Terminal Functions

TERMINAL		I/O	DESCRIPTIONS
NAME	PIN		
PLRCK	1	I	Left and right clock (f_s) input for PCM-format operation. WDCK clock input in external DF mode. Connected to ground in DSD mode ⁽¹⁾
PBCK	2	I	Bit clock input for PCM mode. Connected to GND for DSD mode ⁽¹⁾
PDATA	3	I	Serial audio data input for PCM mode ⁽¹⁾
DBCK	4	I	Bit clock input for DSD mode. Connected to ground in PCM mode ⁽¹⁾
SCK	5	I	System clock input ⁽¹⁾
$\overline{\text{RST}}$	6	I	Reset ⁽¹⁾
V _{DD}	7		Digital power supply, 3.3V
DGND	8		Digital ground
AGNDF	9		Analog ground (DACFF)
V _{CC} R	10		Analog power supply (R-channel I/V), 5 V
AGNDR	11		Analog ground (R-channel I/V)
V _{OUT} R	12	O	R-channel analog voltage output
V _{OUT} R+	13	O	R-channel analog voltage output +
V _{COM}	14		Internal bias decoupling pin
V _{CC} C	15		Analog power supply (internal bias and current DAC), 5 V
AGNDC	16		Analog ground (internal bias and current DAC)
V _{OUT} L+	17	O	L-channel analog voltage output +
V _{OUT} L	18	O	L-channel analog voltage output
AGNDL	19		Analog ground (L-channel I/V)
V _{CC} L	20		Analog power supply (L-channel I/V), 5 V
V _{CC} F	21		Analog power supply (DACFF), 5 V
ZEROR	22	O	Zero flag for R-channel
ZEROL	23	O	Zero flag for L-channel
DSDR	24	I	R-channel data input for DSD mode and external DF mode ⁽¹⁾
DSDL	25	I	L-channel data input for DSD mode and external DF mode ⁽¹⁾
MDI	26	I/O	Mode control data input ⁽²⁾
MC	27	I	Mode control clock input ⁽¹⁾
$\overline{\text{MS}}$	28	I/O	Mode control chip select ⁽²⁾

Notes: (1) Schmitt-trigger input, 5-V tolerant
(2) Schmitt-trigger input and output, 5-V tolerant

PIC18LC242-I/SO (VI: IC703)

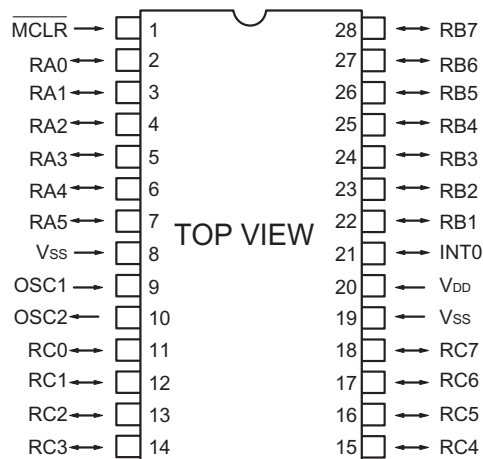

PIC18LC242-I/SO Terminal Function

Pin No.	Pin Name	I/O	Description
1	$\overline{\text{MCLR}}$	I	Master Clear (Reset) input. This pin is an active low RESET to the device.
2	RA0	I/O	Digital I/O.
3	RA1	I/O	Digital I/O.
4	RA2	I/O	Digital I/O.
5	RA3	I/O	Digital I/O.
6	RA4	I/O	Digital I/O. Open drain when configured as output.
7	RA5	I/O	Digital I/O.
8	V _{SS}	P	Ground reference for logic and I/O pins.
9	OSC1	I	Oscillator crystal input or external clock source input. ST buffer when configured in RC mode. CMOS otherwise.
10	OSC2	O	Oscillator crystal output. Connects to crystal or resonator in Crystal Oscillator mode.
11	RC0	I/O	Digital I/O.
12	RC1	I/O	Digital I/O.
13	RC2	I/O	Digital I/O.
14	RC3	I/O	Digital I/O.
15	RC4	I/O	Digital I/O.
16	RC5	I/O	Digital I/O.
17	RC6	I/O	Digital I/O.
18	RC7	I/O	Digital I/O.
19	V _{SS}	P	Ground reference for logic and I/O pins.
20	V _{DD}	P	Positive supply for logic and I/O pins.
21	INT0	I	External Interrupt 0.
22	RB1	I/O	Digital I/O.
23	RB2	I/O	Digital I/O.
24	RB3	I/O	Digital I/O.
25	RB4	I/O	Digital I/O. Interrupt-on-change pin.
26	RB5	I/O	Digital I/O. Interrupt-on-change pin.
27	RB6	I/O	Digital I/O. Interrupt-on-change pin. ICSP programming clock.
28	RB7	I/O	Digital I/O. Interrupt-on-change pin. ICSP programming data.

Legend: O=Output
I=Input
P=Power

BH7860FP (VI: IC706, 707) IC707 for Europe model

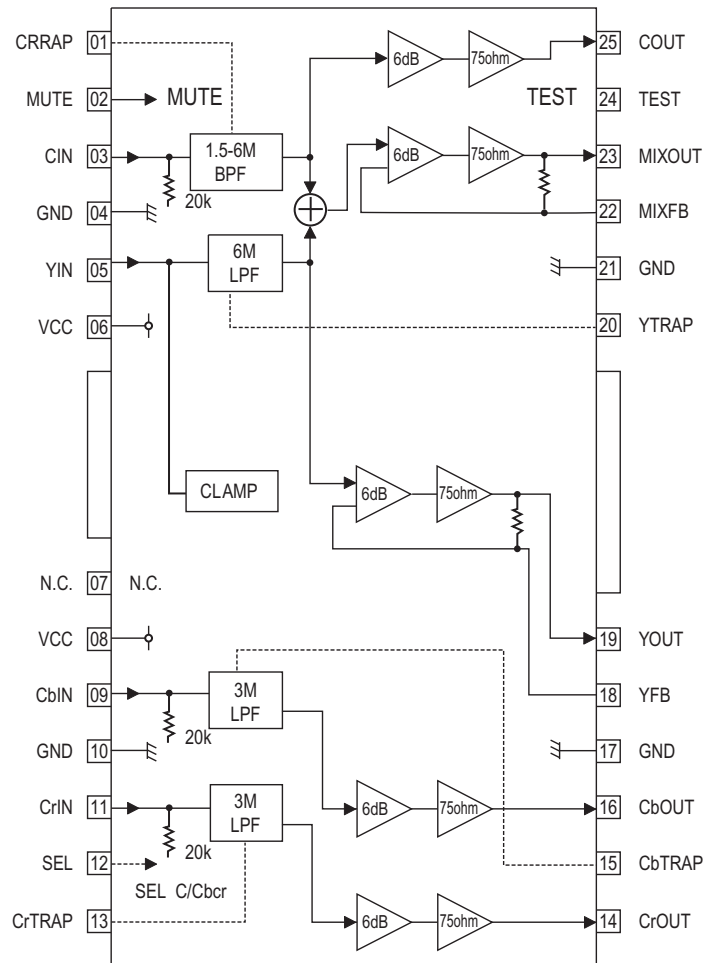

Functions

Pin No.	Pin Name	Functions
1,13,15,20	CTRAP CbTRAP CrTRAP YTRAP	LC oscillation terminal
2	MUTE	Mute control. If MUTE is set to "L", five channels will be muted simultaneously.
3,9,11	CIN CbIN CrIN	Signal input. Chroma signal. The bias type input terminal. Input impedance: 20kohms.
4,10,17,21	GND	It fixed to ground.
5	YIN	Signal input. Input terminal of a luminance signal. Di clamp input .
6,8	VCC	VCC of 6 and 8 pins does not connected inside. Use it by connection externally C, MIX and Y connect with Vcc of 6 pin. Cb and Cr connect with VCC of 8 pin.
12	SEL	C/CbCr select. Cb and Cr are turned off if SEL is set to "L"
14,16	CrOUT CbOUT	Signal output. Color difference signal output.
18,19	YFB YOUT	Signal output. Luminance signal output.
22,23	MIXFB MIXOUT	Signal output. Y/C MIX signal output.
24	TEST	TEST terminal. Usually, please short circuit with GND.
25	COUT	Signal output. Chroma output terminal.

SM8707EU (MA: IC105)

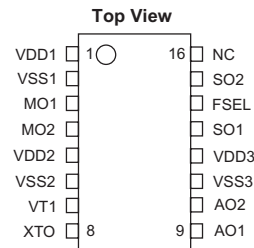

Block Diagram

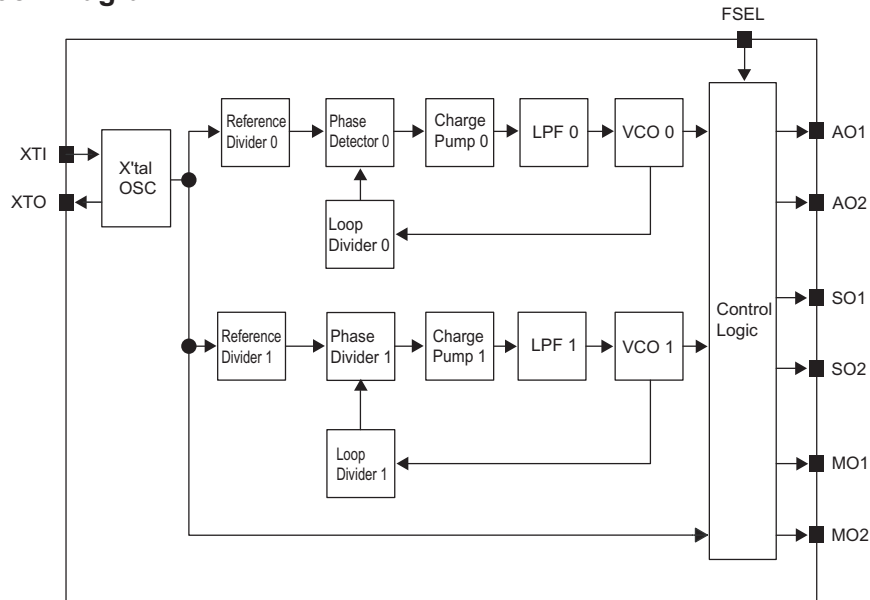

Functions

Number	Name	I/O	Description
1	VDD1		Supply 1 for digital block
2	VSS1		Ground 1 for digital block
3	MO1	O	Video system output 1 (27MHz fixed)
4	MO2	O	Video system output 2 (27MHz fixed)
5	VDD2		Supply 2 for analog block
6	VSS2		Ground 2 for analog block
7	XT1	I	Crystal oscillator connection or external clock input
8	XTO	O	Crystal oscillator connection
9	AO1	O	<SM8707D> Audio system output 1 (384fs/768fs output) FSEL = LOW, fs = 48kHz: 768fs FSEL = HIGH, fs = 44.1kHz: 384fs <SM8707E> Audio system output 1 (512fs output)
10	AO2	O	Audio system output 1 (512fs output)
11	VSS3		Ground 3 for digital block
12	VDD3		Supply 1 for digital block
13	SO1	O	<SM8707D> Signal processor system output 1 (16.9344MHz fixed) <SM8707E> Signal processor system output 1 (33.8688MHz fixed)
14	FSEL	I	<SM8707D> Sampling frequency select FSEL = LOW : fs = 48kHz FSEL = HIGH : fs = 44.1kHz (with internal pull up resistor, Schmidt trigger input) <SM8707E> Sampling frequency select FSEL = LOW : fs = 48kHz FSEL = HIGH : fs = 44.1kHz (with internal pull up resistor, Schmidt trigger input)
15	SO2	O	Signal processor system output 2 (33.8688MHz fixed)
16	NC		No connection (leave pin open circuit or connect to VDD)

STR-F6674 (AU: IC901)

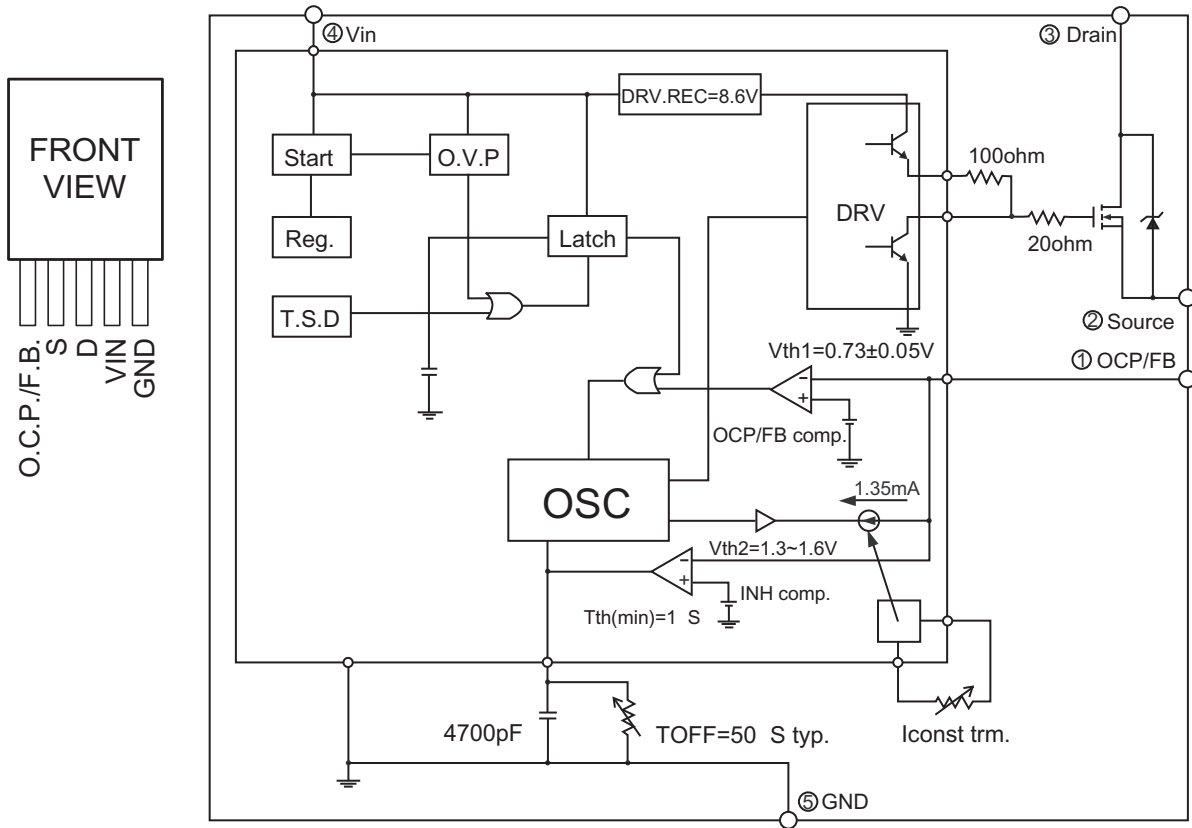

PC123 (AU: IC902)

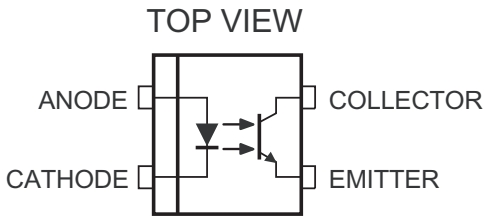

HAT2053M

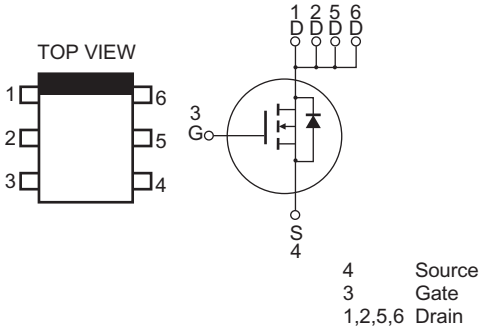

IMD3A

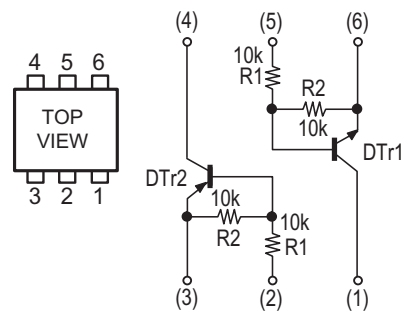

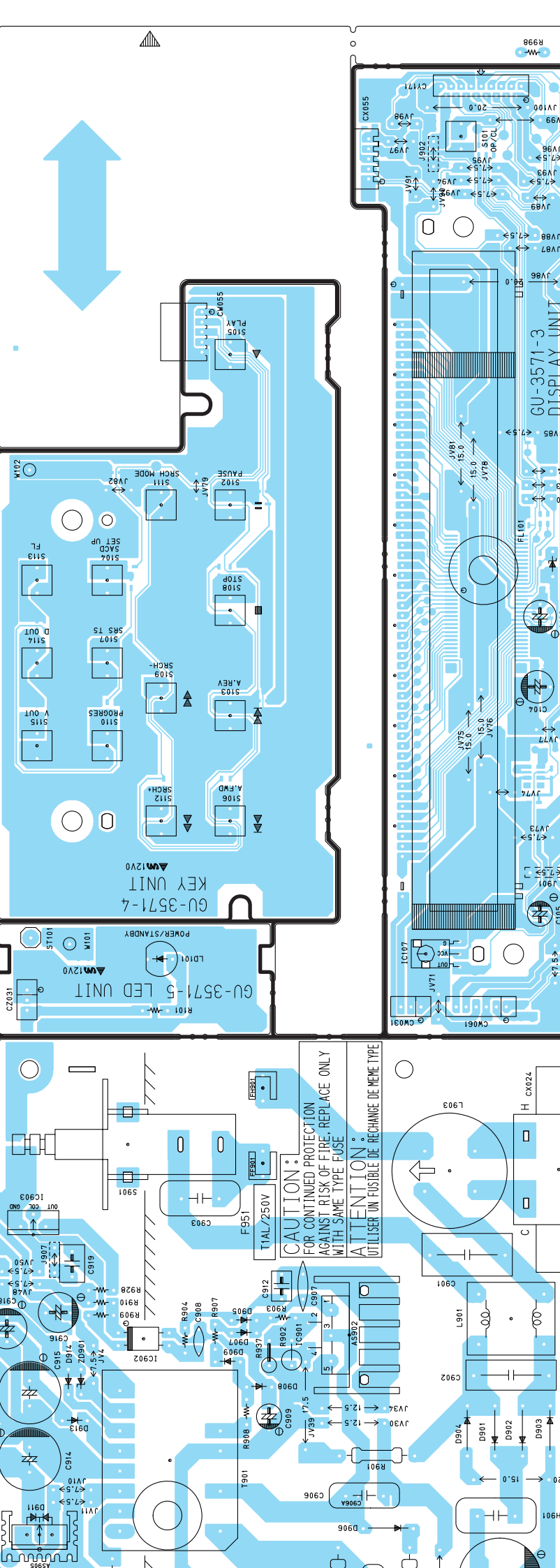
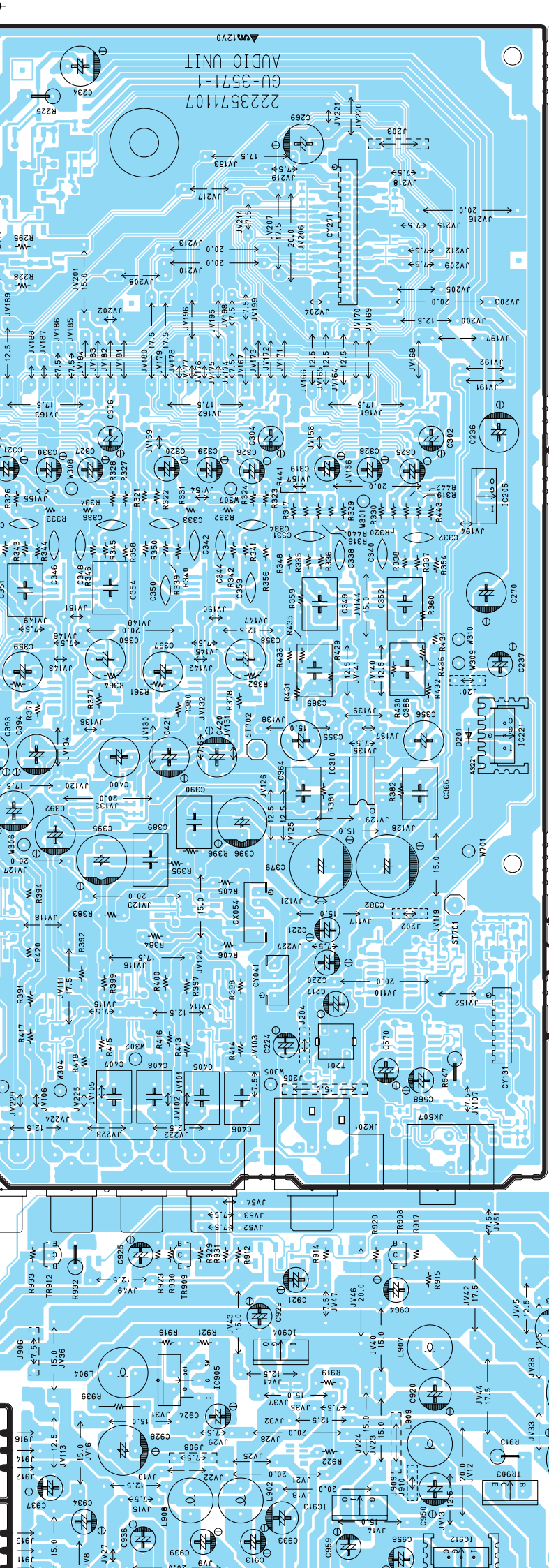

2223572106 GU-3572
VIDEO PWB UNIT

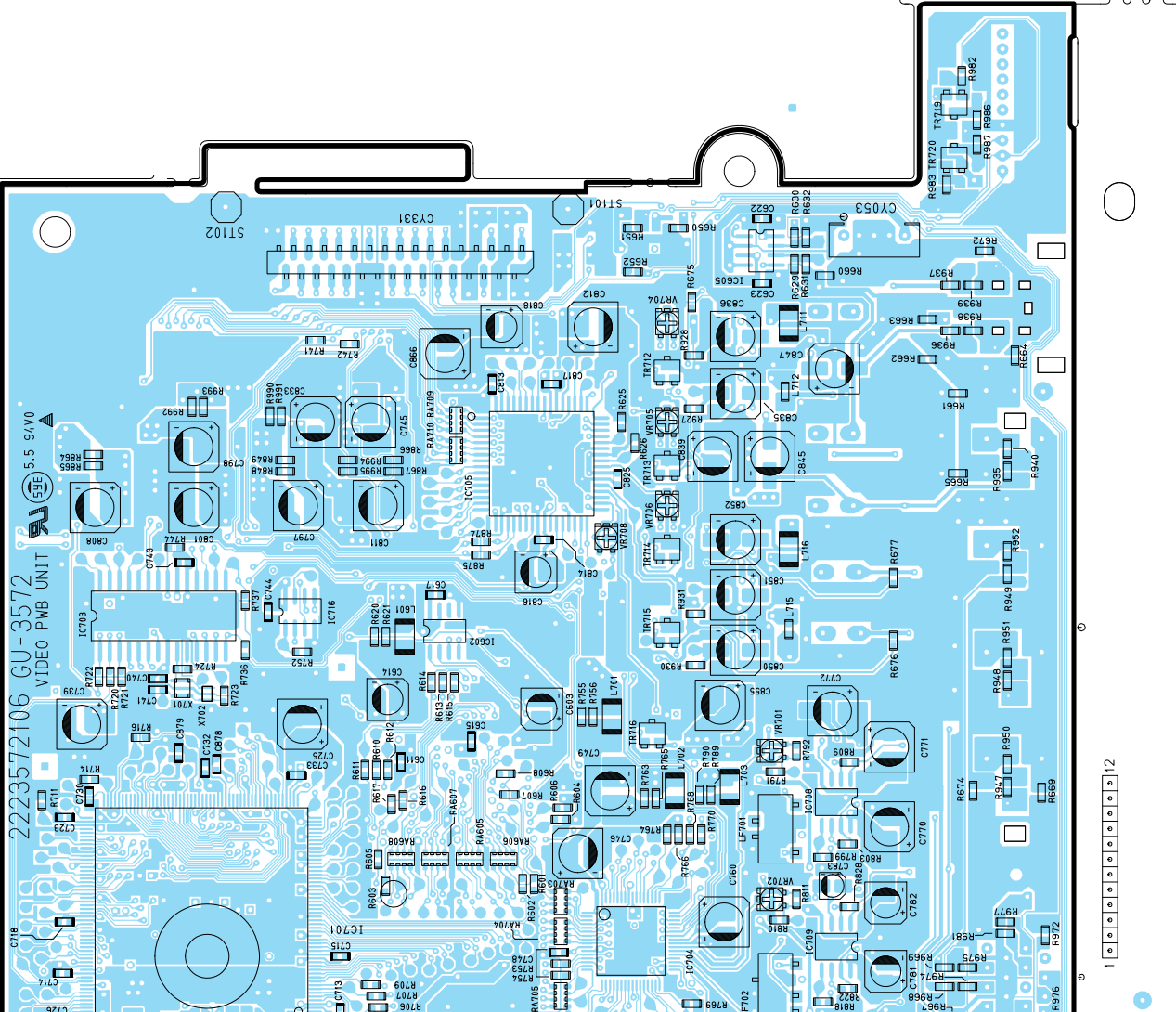

COMPONENT SIDE

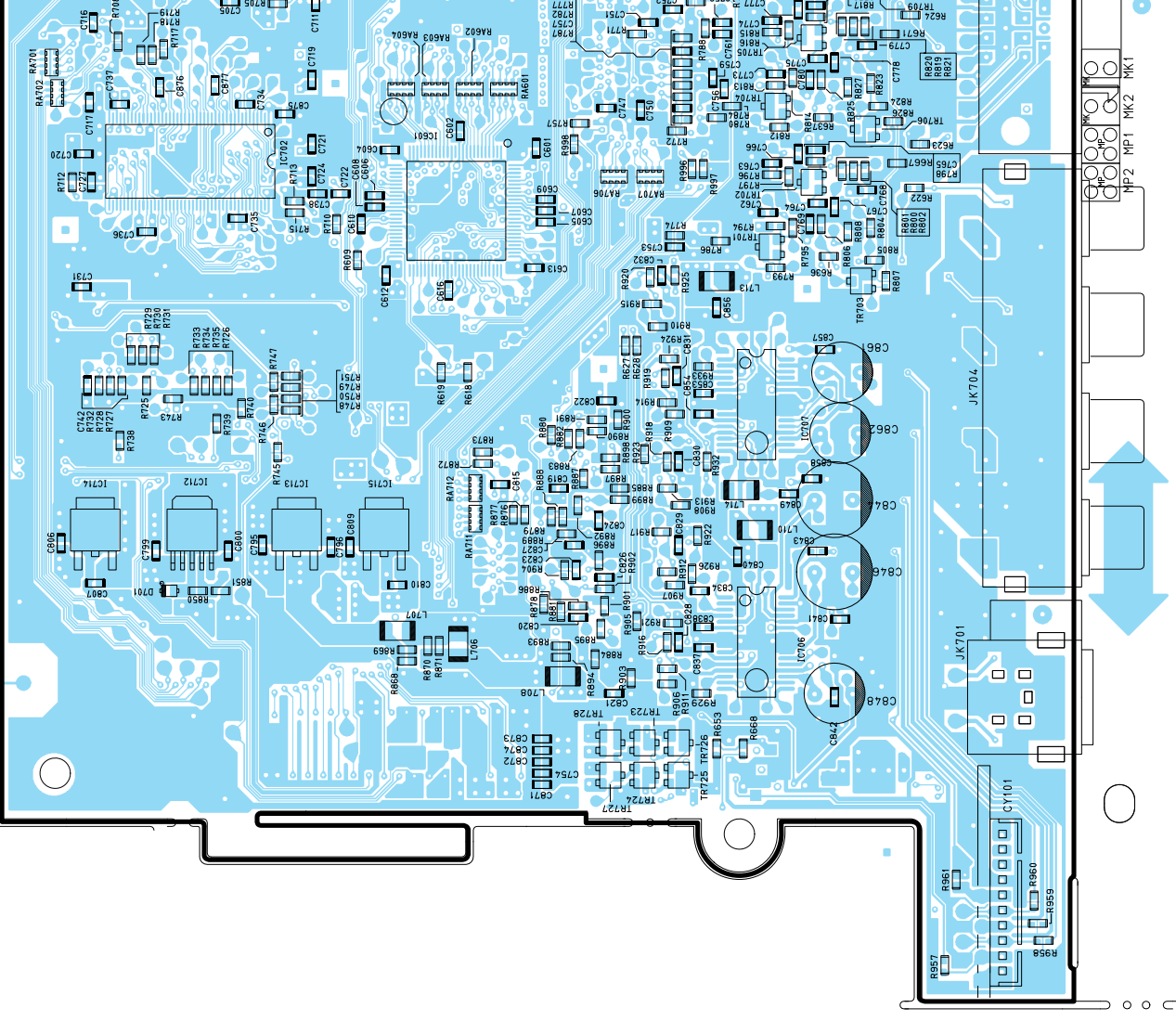

1 2 3 4 5 6 7 8 9 10 11 12

NOTE FOR PARTS LIST

- Part indicated with the mark "◎" are not always in stock and possibly to take a long period of time for supplying, or in some case supplying of part may be refused.
- When ordering of part, clearly indicate "1" and "I" (i) to avoid mis-supplying.
- Ordering part without stating its part number can not be supplied.
- Part indicated with the mark "★" is not illustrated in the exploded view.
- Not including Carbon Film Resister ±5%, 1/4W Type in the P.W.Board parts list. (Refer to the Schematic Diagram for those parts.)
- Not including Carbon Chip Resister 1/16W Type in the P.W.Board parts list. (Refer to the Schematic Diagram for those parts.)

WARNING:

Parts marked with this symbol have critical characteristics. Use ONLY replacement parts recommended by the manufacturer.

部品表について

1. ◎印の部品は常時在庫していませんので供給に長時間を要することがあります。場合によっては、供給をお断りすることがあります。
2. 部品を発注する際は特に数字の“1”と英字の“I”との区別をはっきり記入してください。
3. 部品番号を表示していない部品は供給できません。
4. △印の部品は安全上重要な部品です。交換するとき、安全性維持のため必ず指定の部品をご使用ください。
5. ★印のついてる部品は分解図中には記載していません。
6. カーボン抵抗器 ± 5%、1/4W 型は記載していません。定数は回路図を参照願います。
7. カーボンチップ抵抗器 1/16W 型は記載していません。定数は回路図を参照願います。
8. 部品表の抵抗器、コンデンサの品名記号の読み方は表を参照してください。

● Resistors

Ex.: RN 14K 2E 182 G FR
Type Shape and performance Power Resist-ance Allowable error Others

RD : Carbon RC : Composition RS : Metal oxide film RW : Winding RN : Metal film RK : Metal mixture	2B : 1/8W 2E : 1/4W 2H : 1/2W 3A : 1W 3D : 2W 3F : 3W 3H : 5W	F : ±1% G : ±2% J : ±5% K : ±10% M : ±20%	P : Pulse-resistant type NL : Low noise type NB : Non-burning type FR : Fuse-resistor F : Lead wire forming
---	---	---	---

* Resistance

1 8 2 ⇒ 1800 ohm = 1.8 kohm
Indicates number of zeros after effective number.
2-digit effective number.

● Units: ohm

1 R 2 ⇒ 1.2 ohm
1-digit effective number.
2-digit effective number, decimal point indicated by R.

● Units: ohm

● Capacitors

Ex.: CE 04W 1H 2R2 M BP
Type Shape and performance Dielectric strength Capacity Allowable error Others

CE : Aluminum foil electrolytic CA : Aluminum solid electrolytic CS : Tantalum electrolytic CQ : Film CK : Ceramic CC : Ceramic CP : Oil CM : Mica CF : Metallized CH : Metallized	0J : 6.3V 1A : 10V 1C : 16V 1E : 25V 1V : 35V 1H : 50V 2A : 100V 2B : 125V 2C : 160V 2D : 200V 2E : 250V 2H : 500V 2J : 630V	F : ±1% G : ±2% J : ±5% K : ±10% M : ±20% Z : +80% -20% P : +100% -0% C : ±0.25pF D : ±0.5pF = : Others	HS : High stability type BP : Non-polar type HR : Ripple-resistant type DL : For charge and discharge HF : For assuring high frequency U : UL part C : CSA part W : UL-CSA type F : Lead wire forming
---	--	--	---

* Capacity (electrolyte only)

2 2 2 ⇒ 2200µF
Indicates number of zeros after effective number.
2-digit effective number.

● Units: µF.

2 R 2 ⇒ 2.2µF
1-digit effective number.
2-digit effective number, decimal point indicated by R.

● Units: µF.

* Capacity (except electrolyte)

2 2 2 ⇒ 2200pF=0.0022µF
(More than 2) Indicates number of zeros after effective number.
2-digit effective number.

● Units: pF.

2 2 1 ⇒ 220pF
(0 or 1) Indicates number of zeros after effective number.
2-digit effective number.

● Units: pF.

● When the dielectric strength is indicated in AC, "AC" is included after the dielectric strength value.

● 抵抗器

例) RN 14K 2E 182 G FR
種類 形状特性 電力 抵抗値 許容差 その他

RD : カーボン RC : 固定体 RS : 金属系皮膜 RW : 巻線 RN : 金属皮膜 RK : 金属混合体	2B : 1/8 W 2E : 1/4 W 2H : 1/2 W 3A : 1 W 3D : 2 W 3F : 3 W 3H : 5 W	F : ±1% G : ±2% J : ±5% K : ±10% M : ±20%	P : 耐パルス形 NL : 低雑音形 NB : 不燃形 FR : ヒューズ抵抗 F : リード線成形
---	--	---	---

* 抵抗値

18 2 ⇒ 1800Ω=1.8kΩ
有効数字につづく0の数を表わす。
2桁の有効数字を表わす。

1R 2 ⇒ 1.2Ω
1桁の有効数字を表わす。
2桁の有効数字で小数点はRで表わす。
: 単位はΩ

● コンデンサ

例) CE 04W 1H 2R2 M BP
種類 形状特性 耐圧 容量 許容差 その他

CE : アルミ溶電解 CA : アルミ固体電解 CS : タンタル電解 CQ : フィルム CK : セラミック CC : セラミック CP : オイル CM : マイカ CF : メタライズド CH : メタライズド	0J : 6.3 V 1A : 10 V 1C : 16 V 1E : 25 V 1V : 35 V 1H : 50 V 2A : 100 V 2B : 125 V 2C : 160 V 2D : 200 V 2E : 250 V 2H : 500 V 2J : 630 V	F : ±1% G : ±2% J : ±5% K : ±10% M : ±20% Z : +80% -20% P : +100% -0%	C : ±0.25pF D : ±0.5pF = : その他	HS : 高安定形 BP : 無極性形 HR : 耐リップル形 DL : 充放電対策用 HF : 高周波保証用 U : UL 部品 C : CSA 部品 W : UL-CSA 部品 F : リード線成形
---	---	---	--------------------------------------	---

* 容量値

● 電解コンデンサの場合

22 2 ⇒ 2200µF
有効数字につづく0の数を表わす。
2桁の有効数字を表わす。
: 単位はµF

2R 2 ⇒ 2.2µF
1桁の有効数字を表わす。
2桁の有効数字で小数点はRで表わす。
: 単位はµF

● 電解コンデンサ以外の場合

22 2 ⇒ 2200pF=0.0022µF
有効数字につづく0の数を表わす。
(0の数が2以上の場合)
2桁の有効数字を表わす。
: 単位はpF

22 1 ⇒ 220pF
有効数字につづく0の数を表わす。
(0の数が0または1の場合)
2桁の有効数字を表わす。
: 単位はpF

● 耐圧を交流で表示する場合は、耐圧表示の次に「AC」を表示します。

PARTS LIST OF P.W.B. UNIT ASS'Y (FOR U.S.A. & CANADA MODEL)

GU-3570 MAIN UNIT

	Ref. No.	Part No.	Part Name	Remarks	New
SEMICONDUCTORS GROUP					
	IC101	262 3257 005	M65776BFP		
	IC102	262 3215 005	M32102S6FP		
	IC103	262 3319 008	M29W160DB70N1		
	IC104	262 3119 004	W986416DH 7		
	IC105	262 3216 907	SM8707EV		
	IC106	262 2518 907	SN74LV74APW EL2		
	IC107	262 3046 902	TC7WH157FU		
	IC108	262 2514 901	SN74LV138APW EL2		
	IC109	262 2778 909	SN74LV273ANS		
	IC112	262 1738 908	TC7SU04F (TAPE)		
	IC113	262 3053 908	S 24C02BFJ TB		
	IC114	263 1079 903	BA033FP		
	IC115	262 2977 904	BA18BC0FP E2		
	IC116	263 1110 901	PQ070XZ01ZP		
	IC117	263 1079 903	BA033FP		
	IC118	262 2977 904	BA18BC0FP E2		
	IC201	262 3121 005	ADSPMEL322		
	IC202	262 2964 001	AT49LV002 70TC		
	IC203	262 2959 906	SN74LV244APW		
	IC204 206	262 3129 900	TC74VHC157AF EL		
	IC207	262 3198 902	TC74VHC157FT EL		
	IC301	262 3054 004	MN102H460B		
	IC302	262 3055 003	AT49LV1025 70JC		
	IC303	262 2452 908	MN1382 R(TX)		
	IC401	262 3217 003	CXD2753R		
	IC402	262 2875 006	16M SDRAM(TSOP) 7/8		
	IC403	262 3195 905	AD8062 SO8		
	IC404	262 3282 009	EPM3128ATC100 10		
	IC405	262 2515 900	SN74LV04APW EL2		
	IC501	262 3219 001	CXD1881AR		
	IC502	262 3218 002	CXD1885Q		
	IC503	262 3210 000	M11L16161SA 45T		
	IC505	263 1109 909	AN8471SA		
	IC507	262 1782 909	TC7S08FTE85L		
	IC508	262 3221 002	FAN8042		
	TR501,502	272 0160 901	2SB1132T100Q		
	D101 105	276 0717 903	1SS355 TE 17		
	D301	276 0717 903	1SS355 TE 17		
	D501,502	276 0711 909	MA152WA		
RESISTORS GROUP					
	R101	247 2003 947	RM73B 220JT		
	R102	247 2018 903	RM73B 0R0KT		
	R105	247 2009 983	RM73B 103JT		
	R106	247 2009 909	RM73B 472JT (1608)		
	R107	247 2005 903	RM73B 101JT		
	R108	247 2018 903	RM73B 0R0KT		
	R110 113	247 2018 903	RM73B 0R0KT		
	R114	247 2009 983	RM73B 103JT		
	R115,116	247 2018 903	RM73B 0R0KT		

	Ref. No.	Part No.	Part Name	Remarks	New
	R118	247 2009 983	RM73B 103JT		
	R119	247 2018 903	RM73B 0R0KT		
	R120	247 2009 983	RM73B 103JT		
	R121 123	247 2018 903	RM73B 0R0KT		
	R124	247 2009 983	RM73B 103JT		
	R125	247 2003 989	RM73B 330JT		
	R127,128	247 2018 903	RM73B 0R0KT		
	R129	247 2008 968	RM73B 332JT		
	R130,131	247 2009 983	RM73B 103JT		
	R132	247 2003 989	RM73B 330JT		
	R133	247 2018 903	RM73B 0R0KT		
	R134 137	247 2003 989	RM73B 330JT		
	R138 141	247 2018 903	RM73B 0R0KT		
	R142	247 2003 989	RM73B 330JT		
	R143	247 2018 903	RM73B 0R0KT		
	R144 148	247 2004 920	RM73B 470JT		
	R149,150	247 2008 926	RM73B 222JT		
	R151,152	247 2009 983	RM73B 103JT		
	R153	247 2018 903	RM73B 0R0KT		
	R154	247 2009 983	RM73B 103JT		
	R156	247 2007 943	RM73B 102JT		
	R159	247 2009 983	RM73B 103JT		
	R160 163	247 2004 920	RM73B 470JT		
	R164	247 2009 983	RM73B 103JT		
	R166,167	247 2018 903	RM73B 0R0KT		
	R168	247 2004 920	RM73B 470JT		
	R169	247 2006 960	RM73B 471JT		
	R170	247 2003 947	RM73B 220JT		
	R171	247 2004 920	RM73B 470JT		
	R174	247 2004 920	RM73B 470JT		
	R177	247 2018 903	RM73B 0R0KT		
	R178,179	247 2004 920	RM73B 470JT		
	R180,181	247 2018 903	RM73B 0R0KT		
	R184	247 2004 920	RM73B 470JT		
	R185 192	247 2018 903	RM73B 0R0KT		
	R194 196	247 2018 903	RM73B 0R0KT		
	R197,198	247 2009 983	RM73B 103JT		
	R200,201	247 2009 983	RM73B 103JT		
	R202	247 2018 903	RM73B 0R0KT		
	R203	247 2009 983	RM73B 103JT		
	R205	247 2018 903	RM73B 0R0KT		
	R207	247 2009 983	RM73B 103JT		
	R208	247 2007 943	RM73B 102JT		
	R209 218	247 2009 983	RM73B 103JT		
	R219	247 2018 903	RM73B 0R0KT		
	R220	247 2009 983	RM73B 103JT		
	R221	247 2018 903	RM73B 0R0KT		
	R222 230	247 2009 983	RM73B 103JT		
	R231	247 2014 965	RM73B 105JT		
	R232	247 2007 969	RM73B 122JT		
	R233 236	247 2003 989	RM73B 330JT		
	R237 240	247 2018 903	RM73B 0R0KT		
	R241	247 2003 989	RM73B 330JT		
	R242	247 2018 903	RM73B 0R0KT		
	R243	247 2003 989	RM73B 330JT		
	R248,249	247 2007 943	RM73B 102JT		
	R251 253	247 2018 903	RM73B 0R0KT		
	R255 257	247 2018 903	RM73B 0R0KT		
	R259 261	247 2005 903	RM73B 101JT		
	R262,263	247 2004 920	RM73B 470JT		
	R265	247 2018 903	RM73B 0R0KT		

	Ref. No.	Part No.	Part Name	Remarks	New
	R266 272	247 2009 983	RM73B 103JT		
	R273 281	247 2018 903	RM73B 0R0KT		
	R282 284	247 2003 947	RM73B 220JT		
	R285	247 2009 983	RM73B 103JT		
	R286	247 2018 903	RM73B 0R0KT		
	R288	247 2018 903	RM73B 0R0KT		
	R289 291	247 2003 989	RM73B 330JT		
	R292 297	247 2009 983	RM73B 103JT		
	R298	247 2011 942	RM73B 473JT		
	R302	247 2009 909	RM73B 472JT (1608)		
	R304	247 2009 909	RM73B 472JT (1608)		
	R306	247 2009 909	RM73B 472JT (1608)		
	R308	247 2003 989	RM73B 330JT		
	R309	247 2004 920	RM73B 470JT		
	R310	247 2018 903	RM73B 0R0KT		
	R311	247 2009 983	RM73B 103JT		
	R312	247 2018 903	RM73B 0R0KT		
	R313	247 2009 967	RM73B 822JT		
	R314	247 2008 984	RM73B 392JT		
	R316	247 2005 987	RM73B 221JT		
	R317	247 2018 903	RM73B 0R0KT		
	R319 324	247 2009 983	RM73B 103JT		
	R401 412	247 2003 947	RM73B 220JT		
	R413	247 2018 903	RM73B 0R0KT		
	R414 422	247 2009 983	RM73B 103JT		
	R423	247 2008 968	RM73B 332JT		
	R424	247 2008 926	RM73B 222JT		
	R425,426	247 2008 913	RM73B 202JT		
	R427 431	247 2003 947	RM73B 220JT		
	R432	247 2018 903	RM73B 0R0KT		
	R433	247 2008 926	RM73B 222JT		
	R434 436	247 2018 903	RM73B 0R0KT		
	R437 449	247 2003 947	RM73B 220JT		
	R450 456	247 2003 989	RM73B 330JT		
	R459 463	247 2009 983	RM73B 103JT		
	R464 467	247 2007 943	RM73B 102JT		
	R468	247 2018 903	RM73B 0R0KT		
	R475,476	247 2018 903	RM73B 0R0KT		
	R501	247 2004 988	RM73B 820JT		
	R502	247 2005 903	RM73B 101JT		
	R505 507	247 2018 903	RM73B 0R0KT		
	R508 515	247 2007 985	RM73B 152JT		
	R516 519	247 2004 946	RM73B 560JT		
	R520 523	247 2004 920	RM73B 470JT		
	R524	247 2012 941	RM73B 124JT		
	R527,528	247 2005 903	RM73B 101JT		
	R534	247 2012 941	RM73B 124JT		
	R536	247 2007 943	RM73B 102JT		
	R542	247 2018 903	RM73B 0R0KT		
	R544	247 2007 943	RM73B 102JT		
	R545	247 2019 960	RM73B 123FT		
	R547 552	247 2018 903	RM73B 0R0KT		
	R553	247 2011 900	RM73B 333JT		
	R554,555	247 2009 983	RM73B 103JT		
	R556	247 2007 943	RM73B 102JT		
	R557	247 2010 969	RM73B 223JT		
	R558	247 2008 900	RM73B 182JT		
	R559	247 2012 925	RM73B 104JT		
	R560	247 2011 942	RM73B 473JT		
	R561	247 2011 984	RM73B 683JT		
	R562	247 2006 960	RM73B 471JT		

	Ref. No.	Part No.	Part Name	Remarks	New
	R563	247 2012 967	RM73B 154JT		
	R564	247 2011 942	RM73B 473JT		
	R565	247 2011 968	RM73B 563JT		
	R566	247 2009 983	RM73B 103JT		
	R567	247 2003 989	RM73B 330JT		
	R568	247 2009 983	RM73B 103JT		
	R570	247 2018 903	RM73B 0R0KT		
	R574	247 2018 903	RM73B 0R0KT		
	R577	247 2018 903	RM73B 0R0KT		
	R592 595	247 2018 916	RM73B 010KT		
	R601	247 2010 969	RM73B 223JT		
	R603,604	247 2009 983	RM73B 103JT		
	R616 620	247 2018 903	RM73B 0R0KT		
	R621 633	247 2003 947	RM73B 220JT		
	R634	247 2005 903	RM73B 101JT		
	R635	247 2003 989	RM73B 330JT		
	R636	247 2005 903	RM73B 101JT		
	R637,638	247 2003 989	RM73B 330JT		
	R639 641	247 2005 903	RM73B 101JT		
	R642 644	247 2003 989	RM73B 330JT		
	R645 647	247 2009 983	RM73B 103JT		
	R649 655	247 2005 903	RM73B 101JT		
	R656 659	247 2009 983	RM73B 103JT		
	R660 665	247 2018 903	RM73B 0R0KT		
	R666 669	247 2010 969	RM73B 223JT		
	R670	247 2009 912	RM73B 512JT		
	R671 673	247 2011 968	RM73B 563JT		
	R674 676	247 2011 900	RM73B 333JT		
	R677 679	247 2009 983	RM73B 103JT		
	R680 685	247 2018 903	RM73B 0R0KT		
	R686	247 2009 983	RM73B 103JT		
	R687,688	247 2018 903	RM73B 0R0KT		
	R689,690	247 2009 983	RM73B 103JT		
	R691 694	247 2005 903	RM73B 101JT		
	R697,698	247 2003 989	RM73B 330JT		
	R699	247 2010 969	RM73B 223JT		
	RA101 111	247 9003 908	MNR14=220JE0AB		
	RA112 115	247 9007 917	MNR14=103JE0		
	RA401 405	247 9003 908	MNR14=220JE0AB		
	RA503,504	247 9007 904	MNR14=101JE0		
	RA506 509	247 9007 904	MNR14=101JE0		
	RA523	247 9007 904	MNR14=101JE0		
	RA524 528	247 9007 917	MNR14=103JE0		
CAPACITORS GROUP					
	C103,104	257 4011 905	CE67C0J101MT (RV2)		
	C105,106	257 0511 904	CK73F1H103ZT		
	C107	257 0512 903	CK73F1E104ZT		
	C108,109	257 0511 904	CK73F1H103ZT		
	C110,111	257 0512 903	CK73F1E104ZT		
	C112	257 0511 904	CK73F1H103ZT		
	C113	257 0512 903	CK73F1E104ZT		
	C114	257 0511 904	CK73F1H103ZT		
	C117	257 0512 903	CK73F1E104ZT		
	C118,119	257 4012 917	CE67C1C220MT (RV2)		
	C120,121	257 0512 903	CK73F1E104ZT		
	C122,123	257 0511 904	CK73F1H103ZT		

	Ref. No.	Part No.	Part Name	Remarks	New
	C124	257 0512 903	CK73F1E104ZT		
	C125,126	257 0511 904	CK73F1H103ZT		
	C127 134	257 0512 903	CK73F1E104ZT		
	C136 138	257 0512 903	CK73F1E104ZT		
	C139	257 4011 905	CE67C0J101MT (RV2)		
	C140 143	257 0512 903	CK73F1E104ZT		
	C145,146	257 0512 903	CK73F1E104ZT		
	C147	257 4012 917	CE67C1C220MT (RV2)		
	C151,152	257 0511 904	CK73F1H103ZT		
	C153,154	257 4011 905	CE67C0J101MT (RV2)		
	C155 160	257 0512 903	CK73F1E104ZT		
	C161	257 0511 904	CK73F1H103ZT		
	C162	257 0512 903	CK73F1E104ZT		
	C164	257 0512 903	CK73F1E104ZT		
	C165	257 0506 951	CC73CH1H101JT		
	C166	257 0512 903	CK73F1E104ZT		
	C168 171	257 0512 903	CK73F1E104ZT		
	C172	257 0509 929	CK73B1H102KT		
	C173 176	257 0512 903	CK73F1E104ZT		
	C177,178	257 0502 997	CC73CH1H7R0DT		
	C179	257 0512 903	CK73F1E104ZT		
	C180	257 4011 905	CE67C0J101MT (RV2)		
	C181	257 0512 903	CK73F1E104ZT		
	C182	257 0509 929	CK73B1H102KT		
	C183	257 0512 903	CK73F1E104ZT		
	C184	257 4012 917	CE67C1C220MT (RV2)		
	C185	257 0512 903	CK73F1E104ZT		
	C186	257 0509 929	CK73B1H102KT		
	C189 192	257 0512 903	CK73F1E104ZT		
	C194,195	257 0512 903	CK73F1E104ZT		
	C196	257 0511 904	CK73F1H103ZT		
	C197 200	257 0512 903	CK73F1E104ZT		
	C202	257 4012 917	CE67C1C220MT (RV2)		
	C203,204	257 0512 903	CK73F1E104ZT		
	C205	257 4012 917	CE67C1C220MT (RV2)		
	C206,207	257 0512 903	CK73F1E104ZT		
	C208	257 0504 924	CC73CH1H270JT		
	C209	257 0504 940	CC73CH1H330JT		
	C210	257 0511 904	CK73F1H103ZT		
	C211	257 0509 929	CK73B1H102KT		
	C212	257 0511 904	CK73F1H103ZT		
	C213	257 0509 929	CK73B1H102KT		
	C214	257 0511 904	CK73F1H103ZT		
	C215	257 0509 929	CK73B1H102KT		
	C216	257 0512 903	CK73F1E104ZT		
	C217	257 0509 929	CK73B1H102KT		
	C218	257 0512 903	CK73F1E104ZT		
	C219	257 0509 929	CK73B1H102KT		
	C220,221	257 4012 917	CE67C1C220MT (RV2)		
	C222 225	257 0512 903	CK73F1E104ZT		
	C226	257 0509 929	CK73B1H102KT		
	C227	257 0512 903	CK73F1E104ZT		
	C228	257 0509 929	CK73B1H102KT		
	C230 232	257 4011 905	CE67C0J101MT (RV2)		
	C234,235	257 0512 903	CK73F1E104ZT		
	C236	257 4012 917	CE67C1C220MT (RV2)		
	C237	257 0512 903	CK73F1E104ZT		
	C240	257 0512 903	CK73F1E104ZT		
	C241	257 0509 929	CK73B1H102KT		
	C242	257 0512 903	CK73F1E104ZT		
	C243	257 0509 929	CK73B1H102KT		

	Ref. No.	Part No.	Part Name	Remarks	New
	C244	257 0512 903	CK73F1E104ZT		
	C245	257 4011 905	CE67C0J101MT (RV2)		
	C246	257 4012 917	CE67C1C220MT (RV2)		
	C247,248	257 0511 904	CK73F1H103ZT		
	C249	257 0512 903	CK73F1E104ZT		
	C250	257 0509 929	CK73B1H102KT		
	C251	257 0512 903	CK73F1E104ZT		
	C252	257 0509 929	CK73B1H102KT		
	C253	257 0512 903	CK73F1E104ZT		
	C254,255	257 4012 917	CE67C1C220MT (RV2)		
	C256	247 2018 903	RM73B 0R0KT		
	C257	257 0512 903	CK73F1E104ZT		
	C258	257 0509 929	CK73B1H102KT		
	C259	257 0511 904	CK73F1H103ZT		
	C260,261	257 0512 903	CK73F1E104ZT		
	C268	257 0520 908	CK73B1A154KT		
	C301,302	257 0512 903	CK73F1E104ZT		
	C304,305	257 0512 903	CK73F1E104ZT		
	C306	257 4011 905	CE67C0J101MT (RV2)		
	C307 310	257 0512 903	CK73F1E104ZT		
	C311	257 0503 967	CC73CH1H150JT		
	C312	257 0512 903	CK73F1E104ZT		
	C313	257 0503 967	CC73CH1H150JT		
	C314	257 0509 929	CK73B1H102KT		
	C315,316	257 0512 903	CK73F1E104ZT		
	C317	257 0509 929	CK73B1H102KT		
	C318 320	257 0511 904	CK73F1H103ZT		
	C321	257 4011 905	CE67C0J101MT (RV2)		
	C322	257 0511 904	CK73F1H103ZT		
	C323	257 4012 920	CE67C1C470MT (RV2)		
	C401 403	257 0512 903	CK73F1E104ZT		
	C404	257 4011 905	CE67C0J101MT (RV2)		
	C405	257 0512 903	CK73F1E104ZT		
	C406	257 0501 901	CK73B1H103KT (1608)		
	C407,408	257 0512 903	CK73F1E104ZT		
	C409,410	257 4012 917	CE67C1C220MT (RV2)		
	C411,412	257 0512 903	CK73F1E104ZT		
	C413,414	257 0502 942	CC73CH1H2R0CT		
	C415 419	257 0512 903	CK73F1E104ZT		
	C420	257 4012 917	CE67C1C220MT (RV2)		
	C421,422	257 0512 903	CK73F1E104ZT		
	C423	257 4012 917	CE67C1C220MT (RV2)		
	C424 429	257 0512 903	CK73F1E104ZT		
	C430	257 4011 905	CE67C0J101MT (RV2)		
	C431 440	257 0512 903	CK73F1E104ZT		
	C441	257 4011 905	CE67C0J101MT (RV2)		
	C442	257 0512 903	CK73F1E104ZT		
	C443	257 4012 933	CE67C1C101MT (RV2)		
	C444,445	257 4011 905	CE67C0J101MT (RV2)		
	C447	257 4011 905	CE67C0J101MT (RV2)		
	C448 452	257 0512 903	CK73F1E104ZT		
	C453,454	257 4012 917	CE67C1C220MT (RV2)		
	C455	257 0512 903	CK73F1E104ZT		
	C456	257 4012 917	CE67C1C220MT (RV2)		
	C457 460	257 0512 903	CK73F1E104ZT		
	C461	257 4011 905	CE67C0J101MT (RV2)		
	C463 465	257 0512 903	CK73F1E104ZT		
	C501	257 4012 917	CE67C1C220MT (RV2)		
	C502,503	257 0511 904	CK73F1H103ZT		
	C510	257 4012 917	CE67C1C220MT (RV2)		
	C511,512	257 0511 904	CK73F1H103ZT		

	Ref. No.	Part No.	Part Name	Remarks	New
	C513 516	257 0509 990	CK73B1H222KT		
	C517 520	257 0504 908	CC73CH1H220JT		
	C521	257 0516 954	CK73B1E104KT		
	C522,523	257 0510 934	CK73B1H472KT		
	C524	257 0507 976	CC73CH1H331JT		
	C525,526	257 0511 904	CK73F1H103ZT		
	C527	257 4012 917	CE67C1C220MT (RV2)		
	C528	257 4012 920	CE67C1C470MT (RV2)		
	C529	257 0509 929	CK73B1H102KT		
	C530	257 4012 920	CE67C1C470MT (RV2)		
	C531	257 0509 929	CK73B1H102KT		
	C532 535	257 0516 954	CK73B1E104KT		
	C536	257 0501 901	CK73B1H103KT (1608)		
	C537	257 0516 954	CK73B1E104KT		
	C538	257 0501 901	CK73B1H103KT (1608)		
	C539	257 0506 993	CC73CH1H151JT		
	C540	257 0509 929	CK73B1H102KT		
	C545	257 4011 905	CE67C0J101MT (RV2)		
	C546,547	257 0512 903	CK73F1E104ZT		
	C548	257 0511 904	CK73F1H103ZT		
	C549	257 4012 933	CE67C1C101MT (RV2)		
	C550	257 0512 903	CK73F1E104ZT		
	C551 553	257 0520 911	CK73B1A224KT		
	C554	257 0516 954	CK73B1E104KT		
	C555,556	257 0512 903	CK73F1E104ZT		
	C558	257 0520 911	CK73B1A224KT		
	C559	257 0512 903	CK73F1E104ZT		
	C560	257 4012 917	CE67C1C220MT (RV2)		
	C561	257 0501 901	CK73B1H103KT (1608)		
	C562	257 0516 941	CK73B1E473KT		
	C563,564	257 0511 904	CK73F1H103ZT		
	C565	257 4012 917	CE67C1C220MT (RV2)		
	C566	257 0511 904	CK73F1H103ZT		
	C567	257 4012 917	CE67C1C220MT (RV2)		
	C568	257 0511 904	CK73F1H103ZT		
	C569	257 0508 917	CC73CH1H471JT		
	C570	257 4013 903	CE67C0J471MT (RV)		
	C571	257 4012 917	CE67C1C220MT (RV2)		
	C572 576	257 0511 904	CK73F1H103ZT		
	C578	257 0511 904	CK73F1H103ZT		
	C580	257 0511 904	CK73F1H103ZT		
	C581	257 0516 941	CK73B1E473KT		
	C582 584	257 0511 904	CK73F1H103ZT		
	C585,586	257 0508 917	CC73CH1H471JT		
	C587	257 0511 904	CK73F1H103ZT		
	C588	257 0507 976	CC73CH1H331JT		
	C589	257 0520 908	CK73B1A154KT		
	C590	257 4011 905	CE67C0J101MT (RV2)		
	C591	257 0507 976	CC73CH1H331JT		
	C592	257 0508 917	CC73CH1H471JT		
	C593	257 0520 908	CK73B1A154KT		
	C594	257 0508 917	CC73CH1H471JT		
	C595	257 0516 954	CK73B1E104KT		
	C596	257 0511 904	CK73F1H103ZT		
	C597	257 0506 951	CC73CH1H101JT		
	C598,599	257 0516 909	CK73B1E223KT		
	C600 606	257 0511 904	CK73F1H103ZT		
	C607	257 0512 903	CK73F1E104ZT		
	C608,609	257 4012 917	CE67C1C220MT (RV2)		
	C612	257 0512 903	CK73F1E104ZT		
	C615	257 0509 929	CK73B1H102KT		

	Ref. No.	Part No.	Part Name	Remarks	New
	C616,617	257 0512 903	CK73F1E104ZT		
	C618	257 4012 917	CE67C1C220MT (RV2)		
	C619,620	257 0511 904	CK73F1H103ZT		
	C621	257 4012 917	CE67C1C220MT (RV2)		
	C622 625	257 0511 904	CK73F1H103ZT		
	C629,630	257 4012 917	CE67C1C220MT (RV2)		
	C631,632	257 0510 950	CK73B1H682KT		
	C633	257 0509 929	CK73B1H102KT		
	C634,635	257 0506 951	CC73CH1H101JT		
	C636	257 0501 901	CK73B1H103KT (1608)		
	C637	257 0511 904	CK73F1H103ZT		
	C639	257 0510 950	CK73B1H682KT		
	OTHER PARTS GROUP				
	CX52	205 0863 952	5P PH CON.BASE(L)		
	CX61	205 0792 968	6P ZH ZRCON.BASE(L)T		
	CX131	205 1170 932	13P FFC BASE(FMNBMTT)		
	CX151	205 1149 905	15P FFC BASE(52207)		
	CX171	205 1174 909	17P FFC BASE(FMNSMT)		
	CX241	205 1152 905	24P FFC BASE(FLZ SM1		
	CX271	205 1174 925	27P FFC BASE(FMNSMT)		
	CX331	205 1170 945	33P FFC BASE(FMNBMTT)		
	CY121	205 0895 917	12P PH CON. BASE(T)		
	FB101 104	235 0130 903	CHIP EMIFIL(11A121)		
	FB108,109	235 0130 903	CHIP EMIFIL(11A121)		
	FB110 128	247 2018 903	RM73B 0R0KT		
	FB301 318	247 2018 903	RM73B 0R0KT		
	FB401 403	235 0136 907	FBMJ1608HS280NT		
	FB405 408	235 0136 907	FBMJ1608HS280NT		
	FB501 503	235 0130 903	CHIP EMIFIL(11A121)		
	L101	235 0048 901	EMI FILTER (103)TP		
	X101	399 0619 906	X'TAL(27MHZ)		
	X103	399 0806 900	X'TAL(12.288 FCX03)		
	X301	399 0698 901	CSACW2500MX01		

GU-3571 AUDIO/POWER/DISP UNIT

	Ref. No.	Part No.	Part Name	Remarks	New
SEMICONDUCTORS GROUP					
	IC101	262 3228 908	M66005AFP		
	IC107	499 0306 001	GP1UE271XK		
	IC201	262 1205 907	TC74HCU04AF(TP1)		
	IC202	262 1738 908	TC7SU04F (TAPE)		
	IC205	263 1048 002	BA033T		
	IC221	263 1100 005	KIA7805API		
	IC301 303	262 3299 908	DSD1791DBR		*
	IC304	263 0896 909	NJM2068MD TE1		
	IC306	263 0896 909	NJM2068MD TE1		
	IC307	263 0615 902	BA15218F DXE2		
	IC308	263 0896 909	NJM2068MD TE1		
	IC309	263 0615 902	BA15218F DXE2		
	IC310	263 0609 002	NJM2068DDC		
	IC311	263 0615 902	BA15218F DXE2		
	IC510	262 2580 906	CXA1511M		
	IC901	265 0112 003	STR F6674		
	IC902	262 3047 008	PC123 Y 22		
	IC903	263 1113 005	SE005N		
	IC904	263 1048 002	BA033T		
	IC906	263 0809 006	NJM7805FA(S)		
	IC908	263 0554 005	NJM7905FA		*
	IC909	263 1100 050	KIA7808API		*
	IC912	263 1100 063	KIA7809API		*
	IC913	263 1099 048	KIA7909PI		*
	TR201	269 0119 901	DTA124EKT96(TAPE)		
	TR202	269 0082 902	DTC114EKT96		
	TR203	269 0119 901	DTA124EKT96(TAPE)		
	TR204	269 0082 902	DTC114EKT96		
	TR217	273 0426 907	2SC2412KLNT146		
	TR218	269 0083 901	DTA114EKT96		
	TR219	269 0119 901	DTA124EKT96(TAPE)		
	TR220	269 0082 902	DTC114EKT96		
	TR301 306	273 0460 905	KTC2875B RTK		
	TR309 316	273 0460 905	KTC2875B RTK		
	TR319 327	273 0460 905	KTC2875B RTK		
	TR501	269 0171 907	IMD3A T108		
	TR902	269 0082 902	DTC114EKT96		
	TR903	272 0093 010	2SB1274 (R/S)		
	TR904	275 0106 906	HAT2053M(TAPE)		
	TR905	269 0083 901	DTA114EKT96		
	TR906	269 0082 902	DTC114EKT96		
	TR907	275 0106 906	HAT2053M(TAPE)		
	TR908,909	274 0036 905	2SD468(C)TF		
	TR910,911	269 0083 901	DTA114EKT96		
	TR912	274 0036 905	2SD468(C)TF		
	D101	276 0717 903	1SS355 TE 17		
	D201	276 0432 903	1SS270A TE (TAPE)		
	D202,203	276 0717 903	1SS355 TE 17		
	D206,207	276 0717 903	1SS355 TE 17		
	D901 904	276 0729 904	EM01AT (V1)		
	D905	276 0730 906	AG01ZT (V1)		
	D906	276 0724 909	SARS01T (V1)		
	D907 909	276 0730 906	AG01ZT (V1)		
	D910	276 0725 704	RK39 LF C4		
	D911	276 0783 005	FMB 2204		

	Ref. No.	Part No.	Part Name	Remarks	New
	D912	276 0745 904	RB411DT146		
	D913,914	276 0727 906	AL01ZT (V1)		
	D915	276 0717 903	1SS355 TE 17		
	D918	276 0717 903	1SS355 TE 17		
	D923,924	276 0717 903	1SS355 TE 17		
	D957,958	276 0717 903	1SS355 TE 17		
	D959	276 0737 909	RB161L 40 (TAPE)		
	ZD901	276 0457 904	HZS4C 1TD		
	LD101	393 9504 904	SEL1210S(TP7)		
⚠	TH901	279 0044 002	NTH11D8R0LA		
RESISTORS GROUP					
	R102 104	247 2006 902	RM73B 331JT (1608)		
	R105	247 2010 985	RM73B 273JT		
	R107	247 2018 903	RM73B 0R0KT		
	R109	247 2007 943	RM73B 102JT		
	R111,112	247 2007 943	RM73B 102JT		
	R113	247 2005 945	RM73B 151JT		
	R116	247 2008 984	RM73B 392JT		
	R117,118	247 2018 903	RM73B 0R0KT		
	R119	247 2005 961	RM73B 181JT		
	R120,121	247 2005 945	RM73B 151JT		
	R122,123	247 2005 961	RM73B 181JT		
	R124 126	247 2006 915	RM73B 271JT		
	R127	247 2006 944	RM73B 391JT		
	R128	247 2007 901	RM73B 681JT		
	R129	247 2007 969	RM73B 122JT		
	R130	247 2007 943	RM73B 102JT		
	R131	247 2018 903	RM73B 0R0KT		
	R132	247 2009 967	RM73B 822JT		
	R202	247 2018 903	RM73B 0R0KT		
	R203	247 2011 942	RM73B 473JT		
	R204	247 2003 989	RM73B 330JT		
	R205	247 2018 903	RM73B 0R0KT		
	R206	247 2004 975	RM73B 750JT		
	R207 210	247 2018 903	RM73B 0R0KT		
	R211 219	247 2004 920	RM73B 470JT		
	R220	247 2007 943	RM73B 102JT		
	R221	247 2012 967	RM73B 154JT		
	R222	247 2009 983	RM73B 103JT		
	R223	247 2018 903	RM73B 0R0KT		
	R225	244 2052 915	RS14B3A182JNBST(S)		
	R226	247 2004 991	RM73B 910JT		
	R227	247 2018 903	RM73B 0R0KT		
	R229	247 2006 999	RM73B 621JT		
	R301,302	247 2007 943	RM73B 102JT		
	R303	247 2006 999	RM73B 621JT		
	R304	247 2007 943	RM73B 102JT		
	R305	247 2018 903	RM73B 0R0KT		
	R307	247 2018 903	RM73B 0R0KT		
	R309	247 2018 903	RM73B 0R0KT		
	R311	247 2018 903	RM73B 0R0KT		
	R313	247 2018 903	RM73B 0R0KT		
	R315	247 2018 903	RM73B 0R0KT		
	R365,366	247 2007 985	RM73B 152JT		

	Ref. No.	Part No.	Part Name	Remarks	New
	R367 370	247 2008 913	RM73B 202JT		
	R371 376	247 2011 942	RM73B 473JT		
	R385 388	247 2010 998	RM73B 303JT		
	R401 404	247 2008 942	RM73B 272JT		
	R407,408	247 2008 942	RM73B 272JT		
	R411,412	247 2008 942	RM73B 272JT		
	R421 428	247 2008 942	RM73B 272JT		
	R437	247 2007 943	RM73B 102JT		
	R438	247 2008 926	RM73B 222JT		
	R439	247 2011 942	RM73B 473JT		
	R445	247 2018 903	RM73B 0R0KT		
	R501	247 2009 983	RM73B 103JT		
	R542	247 2007 943	RM73B 102JT		
	R544	247 2007 943	RM73B 102JT		
	R545	247 2006 960	RM73B 471JT		
	R546	247 2012 996	RM73B 204JT		
	R547	244 2052 928	RS14B3A470JNBST(S)		
	R549 551	247 2018 903	RM73B 0R0KT		
	R552	247 2007 943	RM73B 102JT		
	R553	247 2011 926	RM73B 393JT		
	R554	247 2007 943	RM73B 102JT		
	R555 559	247 2018 903	RM73B 0R0KT		
	R580	247 2011 942	RM73B 473JT		
	R585 587	247 2011 942	RM73B 473JT		
	R901	244 2675 716	RS14B3D683JNBF (ERG)		
	R902	244 2671 956	RS14B3DR47JNBST(S)		
	R905	244 2675 729	RS14B3D224JNBF (ERG)		
	R906	244 2675 703	RS14B3D470JNBF (ERG)		
	R913	244 2043 953	RS14B3A471JNBST(S)		
	R932	244 2052 999	RS14B3A103JNBST(S)		
	R937	244 2064 929	RS14B3A3R3JNBST(S)		
	R991	247 2006 902	RM73B 331JT (1608)		
	R992	247 2018 916	RM73B 010KT		
CAPACITORS GROUP					
	C112	257 0509 929	CK73B1H102KT		
	C113	257 0512 903	CK73F1E104ZT		
	C116	257 0509 929	CK73B1H102KT		
	C117,118	257 0512 903	CK73F1E104ZT		
	C119 121	257 0501 901	CK73B1H103KT (1608)		
	C122	257 0506 951	CC73CH1H101JT		
	C123	257 0501 901	CK73B1H103KT (1608)		
	C201	257 0512 903	CK73F1E104ZT		
	C202	257 0511 904	CK73F1H103ZT		
	C203	257 0512 903	CK73F1E104ZT		
	C204	257 0511 904	CK73F1H103ZT		
	C205	257 0512 903	CK73F1E104ZT		
	C206	257 0511 904	CK73F1H103ZT		
	C207,208	257 0512 903	CK73F1E104ZT		
	C209	257 0509 929	CK73B1H102KT		
	C210	257 0512 903	CK73F1E104ZT		
	C211	257 0511 904	CK73F1H103ZT		
	C212	257 0509 929	CK73B1H102KT		
	C213	257 0512 903	CK73F1E104ZT		
	C214,215	257 0509 929	CK73B1H102KT		
	C216	257 0512 903	CK73F1E104ZT		
	C217	254 4525 900	CE04W1H330MT SMG/RE3		
	C218,219	257 0512 903	CK73F1E104ZT		

	Ref. No.	Part No.	Part Name	Remarks	New
	C220,221	254 4538 942	CE04W1C101MT SMG/RE3		
	C223	257 0512 903	CK73F1E104ZT		
	C224	254 4524 985	CE04W1H100MT SMG/RE3		
	C225	257 0509 929	CK73B1H102KT		
	C226	257 0501 901	CK73B1H103KT (1608)		
	C228	257 0512 903	CK73F1E104ZT		
	C229	257 0509 929	CK73B1H102KT		
	C232	257 0512 903	CK73F1E104ZT		
	C233	257 0509 929	CK73B1H102KT		
	C234	254 4538 955	CE04W1C221MT SMG/RE3		
	C235	257 0512 903	CK73F1E104ZT		
	C236	254 4313 950	CE04W1H101MT(ASF)		
	C242	257 0512 903	CK73F1E104ZT		
	C270	254 4313 950	CE04W1H101MT(ASF)		
	C301	257 0511 904	CK73F1H103ZT		
	C302	254 4313 921	CE04W1H220MT(ASF)		
	C303	257 0511 904	CK73F1H103ZT		
	C304	254 4538 913	CE04W1C220MT SMG/RE3		
	C305	257 0511 904	CK73F1H103ZT		
	C306	254 4538 913	CE04W1C220MT SMG/RE3		
	C307 309	257 0512 903	CK73F1E104ZT		
	C310 318	257 0511 904	CK73F1H103ZT		
	C319	254 4313 921	CE04W1H220MT(ASF)		
	C320,321	254 4538 913	CE04W1C220MT SMG/RE3		
	C322 324	257 0512 903	CK73F1E104ZT		
	C325	254 4313 963	CE04W1H010MT(ASF)		
	C326,327	254 4524 943	CE04W1H010MT SMG/RE3		
	C331,332	253 1180 921	CK45B1H102KT(DD 3)		
	C333 336	253 1115 909	CK45B1H182KT		
	C338	253 1179 958	CK45B1H271KT(DD 3)		
	C340	253 1179 958	CK45B1H271KT(DD 3)		
	C342	253 1179 990	CK45B1H561KT(DD 3)		
	C344	253 1179 990	CK45B1H561KT(DD 3)		
	C346	253 1179 990	CK45B1H561KT(DD 3)		
	C348	253 1179 990	CK45B1H561KT(DD 3)		
	C349	253 1179 958	CK45B1H271KT(DD 3)		
	C350	253 1179 990	CK45B1H561KT(DD 3)		
	C351	255 4253 958	CQ93P2A561JT(NH2)		
	C352	253 1179 958	CK45B1H271KT(DD 3)		
	C353	253 1179 990	CK45B1H561KT(DD 3)		
	C354	255 4253 958	CQ93P2A561JT(NH2)		
	C355 360	254 4598 908	CE04W1H220MTBP(ASF)		
	C361 363	257 0509 929	CK73B1H102KT		
	C364	255 4232 940	CQ93P2A182JT(NH)		
	C365	257 0509 929	CK73B1H102KT		
	C366	255 4232 940	CQ93P2A182JT(NH)		
	C367 373	257 0512 903	CK73F1E104ZT		
	C374	257 0509 929	CK73B1H102KT		
	C375 378	257 0512 903	CK73F1E104ZT		
	C379	254 4313 950	CE04W1H101MT(ASF)		
	C382	254 4313 950	CE04W1H101MT(ASF)		
	C387,388	257 0512 903	CK73F1E104ZT		
	C389,390	255 4235 934	CQ93P2A103JT(NH)		
	C391 394	254 4313 950	CE04W1H101MT(ASF)		
	C395,396	254 4313 798	CE04W1H221MC(ASF)		
	C397 399	257 0512 903	CK73F1E104ZT		
	C400	254 4598 908	CE04W1H220MTBP(ASF)		
	C401	257 0511 904	CK73F1H103ZT		
	C402	257 0512 903	CK73F1E104ZT		
	C405 408	255 1273 986	CQ93M1H471JT(B)		
	C409 412	257 0509 990	CK73B1H222KT		

	Ref. No.	Part No.	Part Name	Remarks	New
	C413 416	247 2018 903	RM73B 0R0KT		
	C420,421	254 4313 950	CE04W1H101MT(ASF)		
	C501	257 0511 904	CK73F1H103ZT		
	C502	257 0509 929	CK73B1H102KT		
	C505	257 0512 903	CK73F1E104ZT		
	C509	257 0512 903	CK73F1E104ZT		
	C510	257 0509 929	CK73B1H102KT		
	C511	257 0511 904	CK73F1H103ZT		
	C566	257 0506 951	CC73CH1H101JT		
	C567	257 0501 901	CK73B1H103KT (1608)		
	C568	254 4538 939	CE04W1C470MT SMG/RE3		
	C569	257 0501 901	CK73B1H103KT (1608)		
	C570	254 4524 943	CE04W1H010MT SMG/RE3		
	C571	257 0501 901	CK73B1H103KT (1608)		
	C573	257 0501 901	CK73B1H103KT (1608)		
	C574	257 0509 929	CK73B1H102KT		
	C575	257 0501 901	CK73B1H103KT (1608)		
	C593,594	257 0511 904	CK73F1H103ZT		
⚠	C901	256 8038 017	CF99 2EAC224M		
⚠	C902	256 8038 004	CF99 2EAC104M		
⚠	C903	253 8022 707	CK45F2EAC103MC		
	C905	254 4589 713	CE04W2G101MC(KMG)		
	C906	253 4546 711	CC45SL3D221JC		
⚠	C907	253 4452 902	CC45SL1H471JT		
	C908	253 9030 963	CK45=1E103KT		
	C909	254 4522 945	CE04W1V470MT SMG/RE3		
	C910	253 8029 700	CK45F2EAC222MC (KX)		
	C911	253 8028 701	CK45R3A222KC		
	C912	255 1249 923	CQ93M1H681JT (B)		
	C913	254 4533 921	CE04W0J101MT SMG/RE3		
	C914	254 4592 700	CE04W0J222MC K20(LXV		
	C915	254 4593 709	CE04W1C122MC K20(LXJ		
	C916	254 4591 905	CE04W1H101MT (KMF)		
	C917	254 4593 709	CE04W1C122MC K20(LXJ		
	C918	254 4591 905	CE04W1H101MT (KMF)		
	C919	256 1058 971	CF93A1H104JT (JL)		
	C920	254 4538 955	CE04W1C221MT SMG/RE3		
	C921	254 4533 921	CE04W0J101MT SMG/RE3		
	C923	257 0512 903	CK73F1E104ZT		
	C925	254 4522 945	CE04W1V470MT SMG/RE3		
	C929	254 4533 921	CE04W0J101MT SMG/RE3		
	C930 932	257 0512 903	CK73F1E104ZT		
	C934	254 4533 921	CE04W0J101MT SMG/RE3		
	C935	257 0512 903	CK73F1E104ZT		
	C936	254 4538 942	CE04W1C101MT SMG/RE3		
	C937	254 4533 921	CE04W0J101MT SMG/RE3		
	C938	257 0512 903	CK73F1E104ZT		
	C939	254 4538 942	CE04W1C101MT SMG/RE3		
	C940,941	257 0511 904	CK73F1H103ZT		
	C942 945	257 0512 903	CK73F1E104ZT		
	C948	257 0512 903	CK73F1E104ZT		
	C949	257 0511 904	CK73F1H103ZT		
	C950	254 4538 955	CE04W1C221MT SMG/RE3		
	C951	257 0512 903	CK73F1E104ZT		
	C954 957	257 0512 903	CK73F1E104ZT		
	C958,959	254 4538 942	CE04W1C101MT SMG/RE3		
	C960	257 0511 904	CK73F1H103ZT		
	C964	254 4538 942	CE04W1C101MT SMG/RE3		
	C983 985	257 0512 903	CK73F1E104ZT		

	Ref. No.	Part No.	Part Name	Remarks	New
OTHER PARTS GROUP					
	CW31 CW55 CW61	203 5320 009 205 1273 004 204 0579 007	3P SAN SAN CON.CORD 5P CON.BASE (9176B) 6P PH SAN CON.CORD		* * *
⚠	CX24 CX41 CX51 CX55 CX61	203 2359 002 205 0343 045 205 0343 058 205 0536 072 205 0343 061	2P INLET 4P CONN.BASE(KR PH) 5P CONN.BASE(KR PH) 5P CONN.SOCKET 6P CONN.BASE(KR PH)		
	CX121	205 0375 026	12P CONN.BASE(KR PH)		
	CY41 CY131 CY171	205 0343 045 205 0892 088 205 1006 080	4P CONN.BASE(KR PH) 13P FFC CON. BASE 17P FFC BASE(P=1)		
	CY271	205 1100 083	27P FFC BASE (P=1)		
⚠	F951	206 1075 001	FUSE (1A)		
	FB201 203	235 0130 903	CHIP EMIFIL(11A121)		
	FB301 313 FB527 FB753 756	247 2018 903 235 0130 903 235 0130 903	RM73B 0R0KT CHIP EMIFIL(11A121) CHIP EMIFIL(11A121)		
	FF901	202 0040 909	FUSE CLIP (TAPE)		
	FH901	202 0040 909	FUSE CLIP (TAPE)		
	FL101	393 8072 000	FL TUBE(15 BT 91GNK)		*
	JK201 JK301 JK507	269 0215 009 204 8668 004 204 8674 001	2P OPT/COAX JACK 8P PIN JACK (AU) 2P MINI JACK(ST)		*
	L901	235 0141 002	LINE FILTER (PLA10A)		
	L902 L903 L907 L908 L909	235 0142 917 239 8019 002 235 0142 917 235 0142 904 235 0142 917	COIL LHL08TB4R7MT LINE FILTER COIL COIL LHL08TB4R7MT COIL LHL08TB220KT COIL LHL08TB4R7MT		
⚠	S101 115 S901 ST101 ST903	212 5604 910 212 1030 009 205 0452 017 205 0452 017	TACT SWITCH TA(ALPS) POWER SWITCH (TV 5) STYLE PIN STYLE PIN		
⚠	T201 T901	231 8063 009 233 6403 007	PULSE TRANS SW TRANSFORMER(WIDE)		
	W301	203 0717 002	1P SIN SIN WIRE		
		417 0592 004	HEAT SINK	1	
		417 0610 009	HEAT SINK(OSH 2430)	1	
		461 0991 026	RUBBER SHEET	2	
		471 3303 016	3X6 CBS Z	1	
		471 3305 027	3X10 CBS	1	

GU-3572 VIDEO UNIT

Ref. No.	Part No.	Part Name	Remarks	New
SEMICONDUCTORS GROUP				
IC603	262 1348 903	TC74HC123AF(TP1)		
IC604	262 2519 906	SN74LV00APW EL2		
IC701	262 3058 000	SII504CM208		
IC702	262 2916 004	64M SDRAM(TSOP)		
IC703	262 3059 902	PIC18LC242 I/SO TAPE		
IC704	262 3050 008	ADV7300		
IC706	262 3020 902	BH7860FP E2		
IC708 710	263 1082 903	TK15420MTL		
IC711	262 1348 903	TC74HC123AF(TP1)		
IC712	263 1110 901	PQ070XZ01ZP		
IC713	263 1079 903	BA033FP		
IC714	262 2977 904	BA18BC0FP E2		
TR701,702	271 0293 901	2SA1022 B		
TR703	274 0163 904	2SD601A		
TR704,705	271 0293 901	2SA1022 B		
TR706	274 0163 904	2SD601A		
TR707,708	271 0293 901	2SA1022 B		
TR709,710	274 0163 904	2SD601A		
TR711,712	271 0293 901	2SA1022 B		
TR713	272 0125 904	2SB709A		
D701 703	276 0717 903	1SS355 TE 17		
RESISTORS GROUP				
R601,602	247 2003 989	RM73B 330JT		
R603	247 2018 903	RM73B 0R0KT		
R605	247 2018 903	RM73B 0R0KT		
R607,608	247 2018 903	RM73B 0R0KT		
R610 612	247 2018 903	RM73B 0R0KT		
R613 617	247 2003 989	RM73B 330JT		
R622 624	247 2018 903	RM73B 0R0KT		
R627,628	247 2018 903	RM73B 0R0KT		
R633	247 2009 983	RM73B 103JT		
R634	247 2018 903	RM73B 0R0KT		
R635	247 2009 983	RM73B 103JT		
R636 640	247 2018 903	RM73B 0R0KT		
R641	247 2008 913	RM73B 202JT		
R642	247 2007 943	RM73B 102JT		
R701	247 2007 943	RM73B 102JT		
R702 705	247 2018 903	RM73B 0R0KT		
R706,707	247 2003 989	RM73B 330JT		
R708	247 2009 983	RM73B 103JT		
R709,710	247 2003 989	RM73B 330JT		
R714,715	247 2018 903	RM73B 0R0KT		
R716	247 2003 989	RM73B 330JT		
R717	247 2018 903	RM73B 0R0KT		
R718	247 2009 909	RM73B 472JT (1608)		
R720,721	247 2003 989	RM73B 330JT		
R722	247 2007 943	RM73B 102JT		
R723	247 2018 903	RM73B 0R0KT		
R724	247 2014 965	RM73B 105JT		
R725	247 2009 909	RM73B 472JT (1608)		
R726 728	247 2008 926	RM73B 222JT		

	Ref. No.	Part No.	Part Name	Remarks	New
	R729,731	247 2018 903	RM73B 0R0KT		
	R733,734	247 2018 903	RM73B 0R0KT		
	R735	247 2009 909	RM73B 472JT (1608)		
	R736,737	247 2003 989	RM73B 330JT		
	R738,739	247 2009 909	RM73B 472JT (1608)		
	R740	247 2008 926	RM73B 222JT		
	R741,742	247 2018 903	RM73B 0R0KT		
	R743	247 2009 909	RM73B 472JT (1608)		
	R744,745	247 2003 989	RM73B 330JT		
	R746,747	247 2018 903	RM73B 0R0KT		
	R753,754	247 2003 989	RM73B 330JT		
	R755,757	247 2018 903	RM73B 0R0KT		
	R758	247 2003 989	RM73B 330JT		
	R759	247 2009 909	RM73B 472JT (1608)		
	R760	247 2018 903	RM73B 0R0KT		
	R761,762	247 2003 989	RM73B 330JT		
	R763,766	247 2018 903	RM73B 0R0KT		
	R767	247 2003 989	RM73B 330JT		
	R771	247 2018 903	RM73B 0R0KT		
	R773	247 2007 943	RM73B 102JT		
	R774,776	247 2018 903	RM73B 0R0KT		
	R777	247 2005 987	RM73B 221JT		
	R780	247 2007 985	RM73B 152JT		
	R781	247 2006 960	RM73B 471JT		
	R785	247 2007 943	RM73B 102JT		
	R788	247 2007 901	RM73B 681JT		
	R789,790	247 2018 903	RM73B 0R0KT		
	R791,792	247 2005 987	RM73B 221JT		
	R793	247 2003 989	RM73B 330JT		
	R794	247 2007 943	RM73B 102JT		
	R795	247 2006 986	RM73B 561JT		
	R796	247 2009 983	RM73B 103JT		
	R797	247 2005 903	RM73B 101JT		
	R798	247 2008 926	RM73B 222JT		
	R799	247 2018 903	RM73B 0R0KT		
	R803,804	247 2018 903	RM73B 0R0KT		
	R805,806	247 2014 965	RM73B 105JT		
	R807	247 2009 983	RM73B 103JT		
	R808,809	247 2008 913	RM73B 202JT		
	R810,811	247 2005 987	RM73B 221JT		
	R812	247 2003 989	RM73B 330JT		
	R813	247 2007 943	RM73B 102JT		
	R814	247 2006 986	RM73B 561JT		
	R815	247 2009 983	RM73B 103JT		
	R816	247 2005 903	RM73B 101JT		
	R817	247 2008 926	RM73B 222JT		
	R818	247 2018 903	RM73B 0R0KT		
	R822,823	247 2018 903	RM73B 0R0KT		
	R824,825	247 2014 965	RM73B 105JT		
	R826	247 2009 983	RM73B 103JT		
	R827,828	247 2008 913	RM73B 202JT		
	R829,830	247 2005 987	RM73B 221JT		
	R831	247 2003 989	RM73B 330JT		
	R832	247 2007 943	RM73B 102JT		
	R833	247 2006 986	RM73B 561JT		
	R834	247 2009 983	RM73B 103JT		
	R835	247 2005 903	RM73B 101JT		
	R836	247 2008 926	RM73B 222JT		
	R837	247 2018 903	RM73B 0R0KT		
	R841,842	247 2018 903	RM73B 0R0KT		
	R843,844	247 2014 965	RM73B 105JT		

	Ref. No.	Part No.	Part Name	Remarks	New
	R845	247 2009 983	RM73B 103JT		
	R846,847	247 2008 913	RM73B 202JT		
	R850 852	247 2007 943	RM73B 102JT		
	R853,854	247 2018 903	RM73B 0R0KT		
	R855	247 2009 983	RM73B 103JT		
	R856	247 2018 903	RM73B 0R0KT		
	R857	247 2009 983	RM73B 103JT		
	R858	247 2007 985	RM73B 152JT		
	R859,860	247 2009 983	RM73B 103JT		
	R861 863	247 2009 909	RM73B 472JT (1608)		
	R885	247 2018 903	RM73B 0R0KT		
	R906,907	247 2005 903	RM73B 101JT		
	R916,917	247 2003 989	RM73B 330JT		
	R921,922	247 2007 943	RM73B 102JT		
	R926,927	247 2018 903	RM73B 0R0KT		
	R929	247 2018 903	RM73B 0R0KT		
	R935,936	247 2004 975	RM73B 750JT		
	R937	247 2004 962	RM73B 680JT		
	R938 940	247 2018 903	RM73B 0R0KT		
	R947 949	247 2004 975	RM73B 750JT		
	R950 952	247 2018 903	RM73B 0R0KT		
	R984,985	247 2018 903	RM73B 0R0KT		
	R988 993	247 2018 903	RM73B 0R0KT		
	R996,997	247 2009 909	RM73B 472JT (1608)		
	R998	247 2003 989	RM73B 330JT		
	RA601 604	247 9002 909	MNR14=330JE0AB		
	RA605 608	247 9007 920	MNR14=0R0JE0		
	RA701 708	247 9002 909	MNR14=330JE0AB		
	VR701 705	211 6148 906	V03PB471MT(RH03ADCS)		
CAPACITORS GROUP					
	C608	257 0512 903	CK73F1E104ZT		
	C616	257 0512 903	CK73F1E104ZT		
	C618,619	257 0509 929	CK73B1H102KT		
	C620,621	257 0512 903	CK73F1E104ZT		
	C701 707	257 0512 903	CK73F1E104ZT		
	C708	257 0511 904	CK73F1H103ZT		
	C709	257 0512 903	CK73F1E104ZT		
	C710	257 4012 917	CE67C1C220MT (RV2)		
	C711	257 0511 904	CK73F1H103ZT		
	C712	257 4011 905	CE67C0J101MT (RV2)		
	C713 715	257 0512 903	CK73F1E104ZT		
	C717 721	257 0512 903	CK73F1E104ZT		
	C723,724	257 0512 903	CK73F1E104ZT		
	C725,726	257 4011 905	CE67C0J101MT (RV2)		
	C727	257 0512 903	CK73F1E104ZT		
	C728	257 4011 905	CE67C0J101MT (RV2)		
	C729 738	257 0512 903	CK73F1E104ZT		
	C739	257 4011 905	CE67C0J101MT (RV2)		
	C742	257 0511 904	CK73F1H103ZT		
	C743	257 0512 903	CK73F1E104ZT		
	C745,746	257 4011 905	CE67C0J101MT (RV2)		
	C747,748	257 0512 903	CK73F1E104ZT		
	C749	257 4011 905	CE67C0J101MT (RV2)		
	C750	257 0512 903	CK73F1E104ZT		
	C752	257 0511 904	CK73F1H103ZT		

	Ref. No.	Part No.	Part Name	Remarks	New
	C753	257 0512 903	CK73F1E104ZT		
	C755,756	257 0512 903	CK73F1E104ZT		
	C758	257 0509 903	CK73B1H821KT		
	C759	257 0512 903	CK73F1E104ZT		
	C760	257 4011 905	CE67C0J101MT (RV2)		
	C761	257 0510 921	CK73B1H392KT		
	C765,766	257 0512 903	CK73F1E104ZT		
	C768,769	257 0512 903	CK73F1E104ZT		
	C770 772	257 4011 905	CE67C0J101MT (RV2)		
	C776,777	257 0512 903	CK73F1E104ZT		
	C779,780	257 0512 903	CK73F1E104ZT		
	C781,782	257 4012 917	CE67C1C220MT (RV2)		
	C783	257 4012 904	CE67C1C100MT (RV2B55)		
	C787,788	257 0512 903	CK73F1E104ZT		
	C790,791	257 0512 903	CK73F1E104ZT		
	C792,793	257 4012 917	CE67C1C220MT (RV2)		
	C794	257 4012 904	CE67C1C100MT (RV2B55)		
	C795,796	257 0512 903	CK73F1E104ZT		
	C797,798	257 4011 905	CE67C0J101MT (RV2)		
	C799,800	257 0512 903	CK73F1E104ZT		
	C801	257 4011 905	CE67C0J101MT (RV2)		
	C802	257 0507 934	CC73CH1H221JT		
	C803	257 0512 903	CK73F1E104ZT		
	C804,805	257 0509 929	CK73B1H102KT		
	C806,807	257 0512 903	CK73F1E104ZT		
	C808	257 4011 905	CE67C0J101MT (RV2)		
	C813	257 0512 903	CK73F1E104ZT		
	C825	257 0512 903	CK73F1E104ZT		
	C828,829	257 0512 903	CK73F1E104ZT		
	C833	257 4011 905	CE67C0J101MT (RV2)		
	C834	257 0501 901	CK73B1H103KT (1608)		
	C835	257 4012 920	CE67C1C470MT (RV2)		
	C837,838	257 0511 904	CK73F1H103ZT		
	C839	257 4011 905	CE67C0J101MT (RV2)		
	C840	257 0512 903	CK73F1E104ZT		
	C841	257 0504 995	CC73CH1H510JT		
	C843	257 0501 901	CK73B1H103KT (1608)		
	C844	254 4327 904	CE04W0J102MT(SMG)		
	C845	257 4011 905	CE67C0J101MT (RV2)		
	C846	254 4327 904	CE04W0J102MT(SMG)		
	C847	257 4011 905	CE67C0J101MT (RV2)		
	C863	257 0512 903	CK73F1E104ZT		
	C864	257 0511 904	CK73F1H103ZT		
	C865	257 0509 929	CK73B1H102KT		
	C867,868	257 0512 903	CK73F1E104ZT		
	C869	257 0511 904	CK73F1H103ZT		
	C870	257 0509 929	CK73B1H102KT		
	C873	257 0512 903	CK73F1E104ZT		
	C875 879	257 0512 903	CK73F1E104ZT		
	OTHER PARTS GROUP				
	CY53	205 0343 058	5P CONN.BASE(KR PH)		
	CY331	205 1170 945	33P FFC BASE(FMNBMTT)		
	JK701	205 1272 005	1P S TERMINAL		*
	JK704	204 8677 008	4P PIN JACK(Y/B/R/V)		*
	L704,705	235 0125 905	INDUCTOR(FLC32C220K)		

	Ref. No.	Part No.	Part Name	Remarks	New
	L710	235 0125 905	INDUCTOR(FLC32C220K)		
	L712	235 0149 907	LK1608R68K T		
	LF701	261 0163 908	ELB4B591N		
	LF702	261 0162 909	ELB4C582N		
	X702	399 0832 903	CSTCG20MOV51 R0		

PARTS LIST OF P.W.B. UNIT ASS'Y (FOR EUROPE MODEL)

GU-3570 MAIN UNIT

	Ref. No.	Part No.	Part Name	Remarks	New
SEMICONDUCTORS GROUP					
	IC101	262 3257 005	M65776BFP		
	IC102	262 3215 005	M32102S6FP		
	IC103	262 3319 008	M29W160DB70N1		
	IC104	262 3119 004	W986416DH 7		
	IC105	262 3216 907	SM8707EV		
	IC106	262 2518 907	SN74LV74APW EL2		
	IC107	262 3046 902	TC7WH157FU		
	IC108	262 2514 901	SN74LV138APW EL2		
	IC109	262 2778 909	SN74LV273ANS		
	IC112	262 1738 908	TC7SU04F (TAPE)		
	IC113	262 3053 908	S 24C02BFJ TB		
	IC114	263 1079 903	BA033FP		
	IC115	262 2977 904	BA18BC0FP E2		
	IC116	263 1110 901	PQ070XZ01ZP		
	IC117	263 1079 903	BA033FP		
	IC118	262 2977 904	BA18BC0FP E2		
	IC201	262 3121 005	ADSPMEL322		
	IC202	262 2964 001	AT49LV002 70TC		
	IC203	262 2959 906	SN74LV244APW		
	IC204 206	262 3129 900	TC74VHC157AF EL		
	IC207	262 3198 902	TC74VHC157FT EL		
	IC301	262 3054 004	MN102H460B		
	IC302	262 3055 003	AT49LV1025 70JC		
	IC303	262 2452 908	MN1382 R(TX)		
	IC401	262 3217 003	CXD2753R		
	IC402	262 2875 006	16M SDRAM(TSOP) 7/8		
	IC403	262 3195 905	AD8062 SO8		
	IC404	262 3282 009	EPM3128ATC100 10		
	IC405	262 2515 900	SN74LV04APW EL2		
	IC501	262 3219 001	CXD1881AR		
	IC502	262 3218 002	CXD1885Q		
	IC503	262 3210 000	M11L16161SA 45T		
	IC505	263 1109 909	AN8471SA		
	IC507	262 1782 909	TC7S08FTE85L		
	IC508	262 3221 002	FAN8042		
	TR501,502	272 0160 901	2SB1132T100Q		
	D101 105	276 0717 903	1SS355 TE 17		
	D301	276 0717 903	1SS355 TE 17		
	D501,502	276 0711 909	MA152WA		
RESISTORS GROUP					
	R101	247 2003 947	RM73B 220JT		
	R102	247 2018 903	RM73B 0R0KT		
	R105	247 2009 983	RM73B 103JT		
	R106	247 2009 909	RM73B 472JT (1608)		
	R107	247 2005 903	RM73B 101JT		
	R108	247 2018 903	RM73B 0R0KT		
	R110 113	247 2018 903	RM73B 0R0KT		
	R114	247 2009 983	RM73B 103JT		
	R115,116	247 2018 903	RM73B 0R0KT		

	Ref. No.	Part No.	Part Name	Remarks	New
	R118	247 2009 983	RM73B 103JT		
	R119	247 2018 903	RM73B 0R0KT		
	R120	247 2009 983	RM73B 103JT		
	R121 123	247 2018 903	RM73B 0R0KT		
	R124	247 2009 983	RM73B 103JT		
	R125	247 2003 989	RM73B 330JT		
	R127,128	247 2018 903	RM73B 0R0KT		
	R129	247 2008 968	RM73B 332JT		
	R130,131	247 2009 983	RM73B 103JT		
	R132	247 2003 989	RM73B 330JT		
	R133	247 2018 903	RM73B 0R0KT		
	R134 137	247 2003 989	RM73B 330JT		
	R138 141	247 2018 903	RM73B 0R0KT		
	R142	247 2003 989	RM73B 330JT		
	R143	247 2018 903	RM73B 0R0KT		
	R144 148	247 2004 920	RM73B 470JT		
	R149,150	247 2008 926	RM73B 222JT		
	R151,152	247 2009 983	RM73B 103JT		
	R153	247 2018 903	RM73B 0R0KT		
	R154	247 2009 983	RM73B 103JT		
	R156	247 2007 943	RM73B 102JT		
	R159	247 2009 983	RM73B 103JT		
	R160 163	247 2004 920	RM73B 470JT		
	R164	247 2009 983	RM73B 103JT		
	R166,167	247 2018 903	RM73B 0R0KT		
	R168	247 2004 920	RM73B 470JT		
	R169	247 2006 960	RM73B 471JT		
	R170	247 2003 947	RM73B 220JT		
	R171	247 2004 920	RM73B 470JT		
	R174	247 2004 920	RM73B 470JT		
	R177	247 2018 903	RM73B 0R0KT		
	R178,179	247 2004 920	RM73B 470JT		
	R180,181	247 2018 903	RM73B 0R0KT		
	R184	247 2004 920	RM73B 470JT		
	R185 192	247 2018 903	RM73B 0R0KT		
	R194 196	247 2018 903	RM73B 0R0KT		
	R197,198	247 2009 983	RM73B 103JT		
	R200,201	247 2009 983	RM73B 103JT		
	R202	247 2018 903	RM73B 0R0KT		
	R203	247 2009 983	RM73B 103JT		
	R205	247 2018 903	RM73B 0R0KT		
	R207	247 2009 983	RM73B 103JT		
	R208	247 2007 943	RM73B 102JT		
	R209 218	247 2009 983	RM73B 103JT		
	R219	247 2018 903	RM73B 0R0KT		
	R220	247 2009 983	RM73B 103JT		
	R221	247 2018 903	RM73B 0R0KT		
	R222 230	247 2009 983	RM73B 103JT		
	R231	247 2014 965	RM73B 105JT		
	R232	247 2007 969	RM73B 122JT		
	R233 236	247 2003 989	RM73B 330JT		
	R237 240	247 2018 903	RM73B 0R0KT		
	R241	247 2003 989	RM73B 330JT		
	R242	247 2018 903	RM73B 0R0KT		
	R243	247 2003 989	RM73B 330JT		
	R248,249	247 2007 943	RM73B 102JT		
	R251 253	247 2018 903	RM73B 0R0KT		
	R255 257	247 2018 903	RM73B 0R0KT		
	R259 261	247 2005 903	RM73B 101JT		
	R262,263	247 2004 920	RM73B 470JT		
	R265	247 2018 903	RM73B 0R0KT		

	Ref. No.	Part No.	Part Name	Remarks	New
	R266 272	247 2009 983	RM73B 103JT		
	R273 281	247 2018 903	RM73B 0R0KT		
	R282 284	247 2003 947	RM73B 220JT		
	R285	247 2009 983	RM73B 103JT		
	R286	247 2018 903	RM73B 0R0KT		
	R288	247 2018 903	RM73B 0R0KT		
	R289 291	247 2003 989	RM73B 330JT		
	R292 297	247 2009 983	RM73B 103JT		
	R298	247 2011 942	RM73B 473JT		
	R302	247 2009 909	RM73B 472JT (1608)		
	R304	247 2009 909	RM73B 472JT (1608)		
	R306	247 2009 909	RM73B 472JT (1608)		
	R308	247 2003 989	RM73B 330JT		
	R309	247 2004 920	RM73B 470JT		
	R310	247 2018 903	RM73B 0R0KT		
	R311	247 2009 983	RM73B 103JT		
	R312	247 2018 903	RM73B 0R0KT		
	R313	247 2009 967	RM73B 822JT		
	R314	247 2008 984	RM73B 392JT		
	R316	247 2005 987	RM73B 221JT		
	R317	247 2018 903	RM73B 0R0KT		
	R319 324	247 2009 983	RM73B 103JT		
	R401 412	247 2003 947	RM73B 220JT		
	R413	247 2018 903	RM73B 0R0KT		
	R414 422	247 2009 983	RM73B 103JT		
	R423	247 2008 968	RM73B 332JT		
	R424	247 2008 926	RM73B 222JT		
	R425,426	247 2008 913	RM73B 202JT		
	R427 431	247 2003 947	RM73B 220JT		
	R432	247 2018 903	RM73B 0R0KT		
	R433	247 2008 926	RM73B 222JT		
	R434 436	247 2018 903	RM73B 0R0KT		
	R437 449	247 2003 947	RM73B 220JT		
	R450 456	247 2003 989	RM73B 330JT		
	R459 463	247 2009 983	RM73B 103JT		
	R464 467	247 2007 943	RM73B 102JT		
	R468	247 2018 903	RM73B 0R0KT		
	R475,476	247 2018 903	RM73B 0R0KT		
	R501	247 2004 988	RM73B 820JT		
	R502	247 2005 903	RM73B 101JT		
	R505 507	247 2018 903	RM73B 0R0KT		
	R508 515	247 2007 985	RM73B 152JT		
	R516 519	247 2004 946	RM73B 560JT		
	R520 523	247 2004 920	RM73B 470JT		
	R524	247 2012 941	RM73B 124JT		
	R527,528	247 2005 903	RM73B 101JT		
	R534	247 2012 941	RM73B 124JT		
	R536	247 2007 943	RM73B 102JT		
	R542	247 2018 903	RM73B 0R0KT		
	R544	247 2007 943	RM73B 102JT		
	R545	247 2019 960	RM73B 123FT		
	R547 552	247 2018 903	RM73B 0R0KT		
	R553	247 2011 900	RM73B 333JT		
	R554,555	247 2009 983	RM73B 103JT		
	R556	247 2007 943	RM73B 102JT		
	R557	247 2010 969	RM73B 223JT		
	R558	247 2008 900	RM73B 182JT		
	R559	247 2012 925	RM73B 104JT		
	R560	247 2011 942	RM73B 473JT		
	R561	247 2011 984	RM73B 683JT		
	R562	247 2006 960	RM73B 471JT		

	Ref. No.	Part No.	Part Name	Remarks	New
	R563	247 2012 967	RM73B 154JT		
	R564	247 2011 942	RM73B 473JT		
	R565	247 2011 968	RM73B 563JT		
	R566	247 2009 983	RM73B 103JT		
	R567	247 2003 989	RM73B 330JT		
	R568	247 2009 983	RM73B 103JT		
	R570	247 2018 903	RM73B 0R0KT		
	R574	247 2018 903	RM73B 0R0KT		
	R577	247 2018 903	RM73B 0R0KT		
	R592 595	247 2018 916	RM73B 010KT		
	R601	247 2010 969	RM73B 223JT		
	R603,604	247 2009 983	RM73B 103JT		
	R616 620	247 2018 903	RM73B 0R0KT		
	R621 633	247 2003 947	RM73B 220JT		
	R634	247 2005 903	RM73B 101JT		
	R635	247 2003 989	RM73B 330JT		
	R636	247 2005 903	RM73B 101JT		
	R637,638	247 2003 989	RM73B 330JT		
	R639 641	247 2005 903	RM73B 101JT		
	R642 644	247 2003 989	RM73B 330JT		
	R645 647	247 2009 983	RM73B 103JT		
	R649 655	247 2005 903	RM73B 101JT		
	R656 659	247 2009 983	RM73B 103JT		
	R660 665	247 2018 903	RM73B 0R0KT		
	R666 669	247 2010 969	RM73B 223JT		
	R670	247 2009 912	RM73B 512JT		
	R671 673	247 2011 968	RM73B 563JT		
	R674 676	247 2011 900	RM73B 333JT		
	R677 679	247 2009 983	RM73B 103JT		
	R680 685	247 2018 903	RM73B 0R0KT		
	R686	247 2009 983	RM73B 103JT		
	R687,688	247 2018 903	RM73B 0R0KT		
	R689,690	247 2009 983	RM73B 103JT		
	R691 694	247 2005 903	RM73B 101JT		
	R697,698	247 2003 989	RM73B 330JT		
	R699	247 2010 969	RM73B 223JT		
	RA101 111	247 9003 908	MNR14=220JE0AB		
	RA112 115	247 9007 917	MNR14=103JE0		
	RA401 405	247 9003 908	MNR14=220JE0AB		
	RA503,504	247 9007 904	MNR14=101JE0		
	RA506 509	247 9007 904	MNR14=101JE0		
	RA523	247 9007 904	MNR14=101JE0		
	RA524 528	247 9007 917	MNR14=103JE0		
CAPACITORS GROUP					
	C103,104	257 4011 905	CE67C0J101MT (RV2)		
	C105,106	257 0511 904	CK73F1H103ZT		
	C107	257 0512 903	CK73F1E104ZT		
	C108,109	257 0511 904	CK73F1H103ZT		
	C110,111	257 0512 903	CK73F1E104ZT		
	C112	257 0511 904	CK73F1H103ZT		
	C113	257 0512 903	CK73F1E104ZT		
	C114	257 0511 904	CK73F1H103ZT		
	C117	257 0512 903	CK73F1E104ZT		
	C118,119	257 4012 917	CE67C1C220MT (RV2)		
	C120,121	257 0512 903	CK73F1E104ZT		
	C122,123	257 0511 904	CK73F1H103ZT		

	Ref. No.	Part No.	Part Name	Remarks	New
	C124	257 0512 903	CK73F1E104ZT		
	C125,126	257 0511 904	CK73F1H103ZT		
	C127 134	257 0512 903	CK73F1E104ZT		
	C136 138	257 0512 903	CK73F1E104ZT		
	C139	257 4011 905	CE67C0J101MT (RV2)		
	C140 143	257 0512 903	CK73F1E104ZT		
	C145,146	257 0512 903	CK73F1E104ZT		
	C147	257 4012 917	CE67C1C220MT (RV2)		
	C151,152	257 0511 904	CK73F1H103ZT		
	C153,154	257 4011 905	CE67C0J101MT (RV2)		
	C155 160	257 0512 903	CK73F1E104ZT		
	C161	257 0511 904	CK73F1H103ZT		
	C162	257 0512 903	CK73F1E104ZT		
	C164	257 0512 903	CK73F1E104ZT		
	C165	257 0506 951	CC73CH1H101JT		
	C166	257 0512 903	CK73F1E104ZT		
	C168 171	257 0512 903	CK73F1E104ZT		
	C172	257 0509 929	CK73B1H102KT		
	C173 176	257 0512 903	CK73F1E104ZT		
	C177,178	257 0502 997	CC73CH1H7R0DT		
	C179	257 0512 903	CK73F1E104ZT		
	C180	257 4011 905	CE67C0J101MT (RV2)		
	C181	257 0512 903	CK73F1E104ZT		
	C182	257 0509 929	CK73B1H102KT		
	C183	257 0512 903	CK73F1E104ZT		
	C184	257 4012 917	CE67C1C220MT (RV2)		
	C185	257 0512 903	CK73F1E104ZT		
	C186	257 0509 929	CK73B1H102KT		
	C189 192	257 0512 903	CK73F1E104ZT		
	C194,195	257 0512 903	CK73F1E104ZT		
	C196	257 0511 904	CK73F1H103ZT		
	C197 200	257 0512 903	CK73F1E104ZT		
	C202	257 4012 917	CE67C1C220MT (RV2)		
	C203,204	257 0512 903	CK73F1E104ZT		
	C205	257 4012 917	CE67C1C220MT (RV2)		
	C206,207	257 0512 903	CK73F1E104ZT		
	C208	257 0504 924	CC73CH1H270JT		
	C209	257 0504 940	CC73CH1H330JT		
	C210	257 0511 904	CK73F1H103ZT		
	C211	257 0509 929	CK73B1H102KT		
	C212	257 0511 904	CK73F1H103ZT		
	C213	257 0509 929	CK73B1H102KT		
	C214	257 0511 904	CK73F1H103ZT		
	C215	257 0509 929	CK73B1H102KT		
	C216	257 0512 903	CK73F1E104ZT		
	C217	257 0509 929	CK73B1H102KT		
	C218	257 0512 903	CK73F1E104ZT		
	C219	257 0509 929	CK73B1H102KT		
	C220,221	257 4012 917	CE67C1C220MT (RV2)		
	C222 225	257 0512 903	CK73F1E104ZT		
	C226	257 0509 929	CK73B1H102KT		
	C227	257 0512 903	CK73F1E104ZT		
	C228	257 0509 929	CK73B1H102KT		
	C230 232	257 4011 905	CE67C0J101MT (RV2)		
	C234,235	257 0512 903	CK73F1E104ZT		
	C236	257 4012 917	CE67C1C220MT (RV2)		
	C237	257 0512 903	CK73F1E104ZT		
	C240	257 0512 903	CK73F1E104ZT		
	C241	257 0509 929	CK73B1H102KT		
	C242	257 0512 903	CK73F1E104ZT		
	C243	257 0509 929	CK73B1H102KT		

	Ref. No.	Part No.	Part Name	Remarks	New
	C244	257 0512 903	CK73F1E104ZT		
	C245	257 4011 905	CE67C0J101MT (RV2)		
	C246	257 4012 917	CE67C1C220MT (RV2)		
	C247,248	257 0511 904	CK73F1H103ZT		
	C249	257 0512 903	CK73F1E104ZT		
	C250	257 0509 929	CK73B1H102KT		
	C251	257 0512 903	CK73F1E104ZT		
	C252	257 0509 929	CK73B1H102KT		
	C253	257 0512 903	CK73F1E104ZT		
	C254,255	257 4012 917	CE67C1C220MT (RV2)		
	C256	247 2018 903	RM73B 0R0KT		
	C257	257 0512 903	CK73F1E104ZT		
	C258	257 0509 929	CK73B1H102KT		
	C259	257 0511 904	CK73F1H103ZT		
	C260,261	257 0512 903	CK73F1E104ZT		
	C268	257 0520 908	CK73B1A154KT		
	C301,302	257 0512 903	CK73F1E104ZT		
	C304,305	257 0512 903	CK73F1E104ZT		
	C306	257 4011 905	CE67C0J101MT (RV2)		
	C307 310	257 0512 903	CK73F1E104ZT		
	C311	257 0503 967	CC73CH1H150JT		
	C312	257 0512 903	CK73F1E104ZT		
	C313	257 0503 967	CC73CH1H150JT		
	C314	257 0509 929	CK73B1H102KT		
	C315,316	257 0512 903	CK73F1E104ZT		
	C317	257 0509 929	CK73B1H102KT		
	C318 320	257 0511 904	CK73F1H103ZT		
	C321	257 4011 905	CE67C0J101MT (RV2)		
	C322	257 0511 904	CK73F1H103ZT		
	C323	257 4012 920	CE67C1C470MT (RV2)		
	C401 403	257 0512 903	CK73F1E104ZT		
	C404	257 4011 905	CE67C0J101MT (RV2)		
	C405	257 0512 903	CK73F1E104ZT		
	C406	257 0501 901	CK73B1H103KT (1608)		
	C407,408	257 0512 903	CK73F1E104ZT		
	C409,410	257 4012 917	CE67C1C220MT (RV2)		
	C411,412	257 0512 903	CK73F1E104ZT		
	C413,414	257 0502 942	CC73CH1H2R0CT		
	C415 419	257 0512 903	CK73F1E104ZT		
	C420	257 4012 917	CE67C1C220MT (RV2)		
	C421,422	257 0512 903	CK73F1E104ZT		
	C423	257 4012 917	CE67C1C220MT (RV2)		
	C424 429	257 0512 903	CK73F1E104ZT		
	C430	257 4011 905	CE67C0J101MT (RV2)		
	C431 440	257 0512 903	CK73F1E104ZT		
	C441	257 4011 905	CE67C0J101MT (RV2)		
	C442	257 0512 903	CK73F1E104ZT		
	C443	257 4012 933	CE67C1C101MT (RV2)		
	C444,445	257 4011 905	CE67C0J101MT (RV2)		
	C447	257 4011 905	CE67C0J101MT (RV2)		
	C448 452	257 0512 903	CK73F1E104ZT		
	C453,454	257 4012 917	CE67C1C220MT (RV2)		
	C455	257 0512 903	CK73F1E104ZT		
	C456	257 4012 917	CE67C1C220MT (RV2)		
	C457 460	257 0512 903	CK73F1E104ZT		
	C461	257 4011 905	CE67C0J101MT (RV2)		
	C463 465	257 0512 903	CK73F1E104ZT		
	C501	257 4012 917	CE67C1C220MT (RV2)		
	C502,503	257 0511 904	CK73F1H103ZT		
	C510	257 4012 917	CE67C1C220MT (RV2)		
	C511,512	257 0511 904	CK73F1H103ZT		

	Ref. No.	Part No.	Part Name	Remarks	New
	C513 516	257 0509 990	CK73B1H222KT		
	C517 520	257 0504 908	CC73CH1H220JT		
	C521	257 0516 954	CK73B1E104KT		
	C522,523	257 0510 934	CK73B1H472KT		
	C524	257 0507 976	CC73CH1H331JT		
	C525,526	257 0511 904	CK73F1H103ZT		
	C527	257 4012 917	CE67C1C220MT (RV2)		
	C528	257 4012 920	CE67C1C470MT (RV2)		
	C529	257 0509 929	CK73B1H102KT		
	C530	257 4012 920	CE67C1C470MT (RV2)		
	C531	257 0509 929	CK73B1H102KT		
	C532 535	257 0516 954	CK73B1E104KT		
	C536	257 0501 901	CK73B1H103KT (1608)		
	C537	257 0516 954	CK73B1E104KT		
	C538	257 0501 901	CK73B1H103KT (1608)		
	C539	257 0506 993	CC73CH1H151JT		
	C540	257 0509 929	CK73B1H102KT		
	C545	257 4011 905	CE67C0J101MT (RV2)		
	C546,547	257 0512 903	CK73F1E104ZT		
	C548	257 0511 904	CK73F1H103ZT		
	C549	257 4012 933	CE67C1C101MT (RV2)		
	C550	257 0512 903	CK73F1E104ZT		
	C551 553	257 0520 911	CK73B1A224KT		
	C554	257 0516 954	CK73B1E104KT		
	C555,556	257 0512 903	CK73F1E104ZT		
	C558	257 0520 911	CK73B1A224KT		
	C559	257 0512 903	CK73F1E104ZT		
	C560	257 4012 917	CE67C1C220MT (RV2)		
	C561	257 0501 901	CK73B1H103KT (1608)		
	C562	257 0516 941	CK73B1E473KT		
	C563,564	257 0511 904	CK73F1H103ZT		
	C565	257 4012 917	CE67C1C220MT (RV2)		
	C566	257 0511 904	CK73F1H103ZT		
	C567	257 4012 917	CE67C1C220MT (RV2)		
	C568	257 0511 904	CK73F1H103ZT		
	C569	257 0508 917	CC73CH1H471JT		
	C570	257 4013 903	CE67C0J471MT (RV)		
	C571	257 4012 917	CE67C1C220MT (RV2)		
	C572 576	257 0511 904	CK73F1H103ZT		
	C578	257 0511 904	CK73F1H103ZT		
	C580	257 0511 904	CK73F1H103ZT		
	C581	257 0516 941	CK73B1E473KT		
	C582 584	257 0511 904	CK73F1H103ZT		
	C585,586	257 0508 917	CC73CH1H471JT		
	C587	257 0511 904	CK73F1H103ZT		
	C588	257 0507 976	CC73CH1H331JT		
	C589	257 0520 908	CK73B1A154KT		
	C590	257 4011 905	CE67C0J101MT (RV2)		
	C591	257 0507 976	CC73CH1H331JT		
	C592	257 0508 917	CC73CH1H471JT		
	C593	257 0520 908	CK73B1A154KT		
	C594	257 0508 917	CC73CH1H471JT		
	C595	257 0516 954	CK73B1E104KT		
	C596	257 0511 904	CK73F1H103ZT		
	C597	257 0506 951	CC73CH1H101JT		
	C598,599	257 0516 909	CK73B1E223KT		
	C600 606	257 0511 904	CK73F1H103ZT		
	C607	257 0512 903	CK73F1E104ZT		
	C608,609	257 4012 917	CE67C1C220MT (RV2)		
	C612	257 0512 903	CK73F1E104ZT		
	C615	257 0509 929	CK73B1H102KT		

	Ref. No.	Part No.	Part Name	Remarks	New
	C616,617	257 0512 903	CK73F1E104ZT		
	C618	257 4012 917	CE67C1C220MT (RV2)		
	C619,620	257 0511 904	CK73F1H103ZT		
	C621	257 4012 917	CE67C1C220MT (RV2)		
	C622 625	257 0511 904	CK73F1H103ZT		
	C629,630	257 4012 917	CE67C1C220MT (RV2)		
	C631,632	257 0510 950	CK73B1H682KT		
	C633	257 0509 929	CK73B1H102KT		
	C634,635	257 0506 951	CC73CH1H101JT		
	C636	257 0501 901	CK73B1H103KT (1608)		
	C637	257 0511 904	CK73F1H103ZT		
	C639	257 0510 950	CK73B1H682KT		
	OTHER PARTS GROUP				
	CX52	205 0863 952	5P PH CON.BASE(L)		
	CX61	205 0792 968	6P ZH ZRCON.BASE(L)T		
	CX131	205 1170 932	13P FFC BASE(FMNBMTT)		
	CX151	205 1149 905	15P FFC BASE(52207)		
	CX171	205 1174 909	17P FFC BASE(FMNSMT)		
	CX241	205 1152 905	24P FFC BASE(FLZ SM1		
	CX271	205 1174 925	27P FFC BASE(FMNSMT)		
	CX331	205 1170 945	33P FFC BASE(FMNBMTT)		
	CY121	205 0895 917	12P PH CON. BASE(T)		
	FB101 104	235 0130 903	CHIP EMIFIL(11A121)		
	FB108,109	235 0130 903	CHIP EMIFIL(11A121)		
	FB110 128	247 2018 903	RM73B 0R0KT		
	FB301 318	247 2018 903	RM73B 0R0KT		
	FB401 403	235 0136 907	FBMJ1608HS280NT		
	FB405 408	235 0136 907	FBMJ1608HS280NT		
	FB501 503	235 0130 903	CHIP EMIFIL(11A121)		
	L101	235 0048 901	EMI FILTER (103)TP		
	X101	399 0619 906	X'TAL(27MHZ)		
	X103	399 0806 900	X'TAL(12.288 FCX03)		
	X301	399 0698 901	CSACW2500MX01		

GU-3571A AUD/POW/DISP UNIT A

	Ref. No.	Part No.	Part Name	Remarks	New
SEMICONDUCTORS GROUP					
	IC101	262 3228 908	M66005AFP		
	IC107	499 0306 001	GP1UE271XK		
	IC201	262 1205 907	TC74HCU04AF(TP1)		
	IC202	262 1738 908	TC7SU04F (TAPE)		
	IC205	263 1048 002	BA033T		
	IC221	263 1100 005	KIA7805API		
	IC301 303	262 3299 908	DSD1791DBR		*
	IC304	263 0896 909	NJM2068MD TE1		
	IC306	263 0896 909	NJM2068MD TE1		
	IC307	263 0615 902	BA15218F DXE2		
	IC308	263 0896 909	NJM2068MD TE1		
	IC309	263 0615 902	BA15218F DXE2		
	IC310	262 2182 003	NE5532AN(PHI)		
	IC311	263 0615 902	BA15218F DXE2		
	IC510	262 2580 906	CXA1511M		
	IC901	265 0112 003	STR F6674		
	IC902	262 3047 008	PC123 Y 22		
	IC903	263 1113 005	SE005N		
	IC904	263 1048 002	BA033T		
	IC906	263 0809 006	NJM7805FA(S)		
	IC908	263 0554 005	NJM7905FA		*
	IC909	263 1100 050	KIA7808API		*
	IC912	263 1100 063	KIA7809API		*
	IC913	263 1099 048	KIA7909PI		*
	TR201	269 0119 901	DTA124EKT96(TAPE)		
	TR202	269 0082 902	DTC114EKT96		
	TR203	269 0119 901	DTA124EKT96(TAPE)		
	TR204	269 0082 902	DTC114EKT96		
	TR217	273 0426 907	2SC2412KLNT146		
	TR218	269 0083 901	DTA114EKT96		
	TR219	269 0119 901	DTA124EKT96(TAPE)		
	TR220	269 0082 902	DTC114EKT96		
	TR301 327	273 0460 905	KTC2875B RTK		
	TR501	269 0171 907	IMD3A T108		
	TR902	269 0082 902	DTC114EKT96		
	TR903	272 0093 010	2SB1274 (R/S)		
	TR904	275 0106 906	HAT2053M(TAPE)		
	TR905	269 0083 901	DTA114EKT96		
	TR906	269 0082 902	DTC114EKT96		
	TR907	275 0106 906	HAT2053M(TAPE)		
	TR908,909	274 0036 905	2SD468(C)TF		
	TR910,911	269 0083 901	DTA114EKT96		
	TR912	274 0036 905	2SD468(C)TF		
	D101	276 0717 903	1SS355 TE 17		
	D201	276 0432 903	1SS270A TE (TAPE)		
	D202,203	276 0717 903	1SS355 TE 17		
	D206,207	276 0717 903	1SS355 TE 17		
	D901 904	276 0729 904	EM01AT (V1)		
	D905	276 0730 906	AG01ZT (V1)		
	D906	276 0724 909	SARS01T (V1)		
	D907 909	276 0730 906	AG01ZT (V1)		
	D910	276 0725 704	RK39 LF C4		
	D911	276 0783 005	FMB 2204		
	D912	276 0745 904	RB411DT146		

	Ref. No.	Part No.	Part Name	Remarks	New
	D913,914	276 0727 906	AL01ZT (V1)		
	D915	276 0717 903	1SS355 TE 17		
	D918	276 0717 903	1SS355 TE 17		
	D923,924	276 0717 903	1SS355 TE 17		
	D957,958	276 0717 903	1SS355 TE 17		
	D959	276 0737 909	RB161L 40 (TAPE)		
	ZD901	276 0457 904	HZS4C 1TD		
	LD101	393 9504 904	SEL1210S(TP7)		
⚠	TH901	279 0044 002	NTH11D8R0LA		
RESISTORS GROUP					
	R102 104	247 2006 902	RM73B 331JT (1608)		
	R105	247 2010 985	RM73B 273JT		
	R107	247 2018 903	RM73B 0R0KT		
	R109	247 2007 943	RM73B 102JT		
	R111,112	247 2007 943	RM73B 102JT		
	R113	247 2005 945	RM73B 151JT		
	R116	247 2008 984	RM73B 392JT		
	R117,118	247 2018 903	RM73B 0R0KT		
	R119	247 2005 961	RM73B 181JT		
	R120,121	247 2005 945	RM73B 151JT		
	R122,123	247 2005 961	RM73B 181JT		
	R124 126	247 2006 915	RM73B 271JT		
	R127	247 2006 944	RM73B 391JT		
	R128	247 2007 901	RM73B 681JT		
	R129	247 2007 969	RM73B 122JT		
	R130	247 2007 943	RM73B 102JT		
	R131	247 2018 903	RM73B 0R0KT		
	R132	247 2009 967	RM73B 822JT		
	R202	247 2018 903	RM73B 0R0KT		
	R203	247 2011 942	RM73B 473JT		
	R204	247 2003 989	RM73B 330JT		
	R205	247 2018 903	RM73B 0R0KT		
	R206	247 2004 975	RM73B 750JT		
	R207 210	247 2018 903	RM73B 0R0KT		
	R211 219	247 2004 920	RM73B 470JT		
	R220	247 2007 943	RM73B 102JT		
	R221	247 2012 967	RM73B 154JT		
	R222	247 2009 983	RM73B 103JT		
	R223	247 2018 903	RM73B 0R0KT		
	R225	244 2052 915	RS14B3A182JNBST(S)		
	R226	247 2004 991	RM73B 910JT		
	R227	247 2018 903	RM73B 0R0KT		
	R229	247 2006 999	RM73B 621JT		
	R301,302	247 2007 943	RM73B 102JT		
	R303	247 2006 999	RM73B 621JT		
	R304	247 2007 943	RM73B 102JT		
	R305	247 2018 903	RM73B 0R0KT		
	R307	247 2018 903	RM73B 0R0KT		
	R309	247 2018 903	RM73B 0R0KT		
	R311	247 2018 903	RM73B 0R0KT		
	R313	247 2018 903	RM73B 0R0KT		
	R315	247 2018 903	RM73B 0R0KT		
	R365,366	247 2007 985	RM73B 152JT		
	R367 370	247 2008 913	RM73B 202JT		

	Ref. No.	Part No.	Part Name	Remarks	New
	R371 376	247 2011 942	RM73B 473JT		
	R385 388	247 2010 998	RM73B 303JT		
	R389,390	247 2008 942	RM73B 272JT		
	R401 404	247 2008 942	RM73B 272JT		
	R407 412	247 2008 942	RM73B 272JT		
	R421 428	247 2008 942	RM73B 272JT		
	R437	247 2007 943	RM73B 102JT		
	R438	247 2008 926	RM73B 222JT		
	R439	247 2011 942	RM73B 473JT		
	R445	247 2018 903	RM73B 0R0KT		
	R501	247 2009 983	RM73B 103JT		
	R542	247 2007 943	RM73B 102JT		
	R544	247 2007 943	RM73B 102JT		
	R545	247 2006 960	RM73B 471JT		
	R546	247 2012 996	RM73B 204JT		
	R547	244 2052 928	RS14B3A470JNBST(S)		
	R549 551	247 2018 903	RM73B 0R0KT		
	R552	247 2007 943	RM73B 102JT		
	R553	247 2011 926	RM73B 393JT		
	R554	247 2007 943	RM73B 102JT		
	R555 559	247 2018 903	RM73B 0R0KT		
	R582 585	247 2011 942	RM73B 473JT		
	R901	244 2675 716	RS14B3D683JNBF (ERG)		
	R902	244 2671 956	RS14B3DR47JNBST(S)		
	R905	244 2675 729	RS14B3D224JNBF (ERG)		
	R906	244 2675 703	RS14B3D470JNBF (ERG)		
	R913	244 2043 953	RS14B3A471JNBST(S)		
	R932	244 2052 999	RS14B3A103JNBST(S)		
	R937	244 2064 929	RS14B3A3R3JNBST(S)		
	R991	247 2006 902	RM73B 331JT (1608)		
	R992	247 2018 916	RM73B 010KT		
CAPACITORS GROUP					
	C112	257 0509 929	CK73B1H102KT		
	C113,114	257 0512 903	CK73F1E104ZT		
	C115,116	257 0509 929	CK73B1H102KT		
	C117,118	257 0512 903	CK73F1E104ZT		
	C119 121	257 0501 901	CK73B1H103KT (1608)		
	C122	257 0506 951	CC73CH1H101JT		
	C123	257 0501 901	CK73B1H103KT (1608)		
	C201	257 0512 903	CK73F1E104ZT		
	C202	257 0511 904	CK73F1H103ZT		
	C203	257 0512 903	CK73F1E104ZT		
	C204	257 0511 904	CK73F1H103ZT		
	C205	257 0512 903	CK73F1E104ZT		
	C206	257 0511 904	CK73F1H103ZT		
	C207,208	257 0512 903	CK73F1E104ZT		
	C209	257 0509 929	CK73B1H102KT		
	C210	257 0512 903	CK73F1E104ZT		
	C211	257 0511 904	CK73F1H103ZT		
	C212	257 0509 929	CK73B1H102KT		
	C213	257 0512 903	CK73F1E104ZT		
	C214,215	257 0509 929	CK73B1H102KT		
	C216	257 0512 903	CK73F1E104ZT		
	C217	254 4525 900	CE04W1H330MT SMG/RE3		
	C218,219	257 0512 903	CK73F1E104ZT		
	C220,221	254 4538 942	CE04W1C101MT SMG/RE3		
	C223	257 0512 903	CK73F1E104ZT		

	Ref. No.	Part No.	Part Name	Remarks	New
	C224	254 4524 985	CE04W1H100MT SMG/RE3		
	C225	257 0509 929	CK73B1H102KT		
	C226	257 0501 901	CK73B1H103KT (1608)		
	C228	257 0512 903	CK73F1E104ZT		
	C229	257 0509 929	CK73B1H102KT		
	C232	257 0512 903	CK73F1E104ZT		
	C233	257 0509 929	CK73B1H102KT		
	C234	254 4538 955	CE04W1C221MT SMG/RE3		
	C235	257 0512 903	CK73F1E104ZT		
	C236	254 4313 950	CE04W1H101MT(ASF)		
	C242	257 0512 903	CK73F1E104ZT		
	C270	254 4313 950	CE04W1H101MT(ASF)		
	C301	257 0511 904	CK73F1H103ZT		
	C302	254 4313 921	CE04W1H220MT(ASF)		
	C303	257 0511 904	CK73F1H103ZT		
	C304	254 4538 913	CE04W1C220MT SMG/RE3		
	C305	257 0511 904	CK73F1H103ZT		
	C306	254 4538 913	CE04W1C220MT SMG/RE3		
	C307 309	257 0512 903	CK73F1E104ZT		
	C310 318	257 0511 904	CK73F1H103ZT		
	C319	254 4313 921	CE04W1H220MT(ASF)		
	C320,321	254 4538 913	CE04W1C220MT SMG/RE3		
	C322 324	257 0512 903	CK73F1E104ZT		
	C325	254 4313 963	CE04W1H010MT(ASF)		
	C326,327	254 4524 943	CE04W1H010MT SMG/RE3		
	C331,332	253 1180 921	CK45B1H102KT(DD 3)		
	C333 336	253 1115 909	CK45B1H182KT		
	C338	253 1179 958	CK45B1H271KT(DD 3)		
	C340	253 1179 958	CK45B1H271KT(DD 3)		
	C342	253 1179 990	CK45B1H561KT(DD 3)		
	C344	253 1179 990	CK45B1H561KT(DD 3)		
	C346	253 1179 990	CK45B1H561KT(DD 3)		
	C348	253 1179 990	CK45B1H561KT(DD 3)		
	C349	253 1179 958	CK45B1H271KT(DD 3)		
	C350	253 1179 990	CK45B1H561KT(DD 3)		
	C351	255 4253 958	CQ93P2A561JT(NH2)		
	C352	253 1179 958	CK45B1H271KT(DD 3)		
	C353	253 1179 990	CK45B1H561KT(DD 3)		
	C354	255 4253 958	CQ93P2A561JT(NH2)		
	C355 360	254 4598 908	CE04W1H220MTBP(ASF)		
	C361 363	257 0509 929	CK73B1H102KT		
	C364	255 4232 940	CQ93P2A182JT(NH)		
	C365	257 0509 929	CK73B1H102KT		
	C366	255 4232 940	CQ93P2A182JT(NH)		
	C367 373	257 0512 903	CK73F1E104ZT		
	C374	257 0509 929	CK73B1H102KT		
	C375 378	257 0512 903	CK73F1E104ZT		
	C379	254 4313 950	CE04W1H101MT(ASF)		
	C382	254 4313 950	CE04W1H101MT(ASF)		
	C387,388	257 0512 903	CK73F1E104ZT		
	C389,390	255 4235 934	CQ93P2A103JT(NH)		
	C391 394	254 4313 950	CE04W1H101MT(ASF)		
	C395,396	254 4313 798	CE04W1H221MC(ASF)		
	C397 399	257 0512 903	CK73F1E104ZT		
	C400	254 4598 908	CE04W1H220MTBP(ASF)		
	C401	257 0511 904	CK73F1H103ZT		
	C402	257 0512 903	CK73F1E104ZT		
	C405 408	255 1273 986	CQ93M1H471JT(B)		
	C409 412	257 0509 990	CK73B1H222KT		
	C413 416	247 2018 903	RM73B 0R0KT		
	C420,421	254 4313 950	CE04W1H101MT(ASF)		

	Ref. No.	Part No.	Part Name	Remarks	New
	C501	257 0511 904	CK73F1H103ZT		
	C502	257 0509 929	CK73B1H102KT		
	C505	257 0512 903	CK73F1E104ZT		
	C509	257 0512 903	CK73F1E104ZT		
	C510	257 0509 929	CK73B1H102KT		
	C511	257 0511 904	CK73F1H103ZT		
	C566	257 0506 951	CC73CH1H101JT		
	C567	257 0501 901	CK73B1H103KT (1608)		
	C568	254 4538 939	CE04W1C470MT SMG/RE3		
	C569	257 0501 901	CK73B1H103KT (1608)		
	C570	254 4524 943	CE04W1H010MT SMG/RE3		
	C571	257 0501 901	CK73B1H103KT (1608)		
	C573	257 0501 901	CK73B1H103KT (1608)		
	C574	257 0509 929	CK73B1H102KT		
	C575	257 0501 901	CK73B1H103KT (1608)		
	C593,594	257 0511 904	CK73F1H103ZT		
⚠	C901	256 8038 017	CF99 2EAC224M		
⚠	C902	256 8038 004	CF99 2EAC104M		
⚠	C903	253 8022 707	CK45F2EAC103MC		
	C905	254 4589 700	CE04W2G470MC (KMG)		
	C906	253 4546 711	CC45SL3D221JC		
	C907	253 4452 902	CC45SL1H471JT		
	C908	253 9030 963	CK45=1E103KT		
	C909	254 4522 945	CE04W1V470MT SMG/RE3		
⚠	C910	253 8029 700	CK45F2EAC222MC (KX)		
	C911	253 8028 701	CK45R3A222KC		
	C912	255 1249 923	CQ93M1H681JT (B)		
	C913	254 4533 921	CE04W0J101MT SMG/RE3		
	C914	254 4592 700	CE04W0J222MC K20(LXV)		
	C915	254 4593 709	CE04W1C122MC K20(LXJ)		
	C916	254 4591 905	CE04W1H101MT (KMF)		
	C917	254 4593 709	CE04W1C122MC K20(LXJ)		
	C918	254 4591 905	CE04W1H101MT (KMF)		
	C919	256 1058 971	CF93A1H104JT (JL)		
	C920	254 4538 955	CE04W1C221MT SMG/RE3		
	C921	254 4533 921	CE04W0J101MT SMG/RE3		
	C923	257 0512 903	CK73F1E104ZT		
	C925	254 4522 945	CE04W1V470MT SMG/RE3		
	C929	254 4533 921	CE04W0J101MT SMG/RE3		
	C930 932	257 0512 903	CK73F1E104ZT		
	C934	254 4533 921	CE04W0J101MT SMG/RE3		
	C935	257 0512 903	CK73F1E104ZT		
	C936	254 4538 942	CE04W1C101MT SMG/RE3		
	C937	254 4533 921	CE04W0J101MT SMG/RE3		
	C938	257 0512 903	CK73F1E104ZT		
	C939	254 4538 942	CE04W1C101MT SMG/RE3		
	C940,941	257 0511 904	CK73F1H103ZT		
	C942 945	257 0512 903	CK73F1E104ZT		
	C948	257 0512 903	CK73F1E104ZT		
	C949	257 0511 904	CK73F1H103ZT		
	C950	254 4538 955	CE04W1C221MT SMG/RE3		
	C951	257 0512 903	CK73F1E104ZT		
	C954 957	257 0512 903	CK73F1E104ZT		
	C958,959	254 4538 942	CE04W1C101MT SMG/RE3		
	C960	257 0511 904	CK73F1H103ZT		
	C964	254 4538 942	CE04W1C101MT SMG/RE3		
	C983 985	257 0512 903	CK73F1E104ZT		

	Ref. No.	Part No.	Part Name	Remarks	New
OTHER PARTS GROUP					
	CW31	203 5320 009	3P SAN SAN CON.CORD		*
	CW55	205 1273 004	5P CON.BASE (9176B)		*
	CW61	204 0579 007	6P PH SAN CON.CORD		*
⚠	CX24	203 2349 009	2P INLET		
	CX41	205 0343 045	4P CONN.BASE(KR PH)		
	CX51	205 0343 058	5P CONN.BASE(KR PH)		
	CX54	205 0321 054	5P CONNE.BASE (RED)		
	CX55	205 0536 072	5P CONN.SOCKET		
	CX61	205 0343 061	6P CONN.BASE(KR PH)		
	CX121	205 0375 026	12P CONN.BASE(KR PH)		
	CY41	205 0343 045	4P CONN.BASE(KR PH)		
	CY131	205 0892 088	13P FFC CON. BASE		
	CY171	205 1006 080	17P FFC BASE(P=1)		
	CY271	205 1100 083	27P FFC BASE (P=1)		
⚠	F951	206 1075 027	FUSE (1.6A)		
	FB201 203	235 0130 903	CHIP EMIFIL(11A121)		
	FB301 306	247 2018 903	RM73B 0R0KT		
	FB312,313	235 0130 903	CHIP EMIFIL(11A121)		
	FB527	235 0130 903	CHIP EMIFIL(11A121)		
	FB753 756	235 0130 903	CHIP EMIFIL(11A121)		
	FF901	202 0040 909	FUSE CLIP (TAPE)		
	FH901	202 0040 909	FUSE CLIP (TAPE)		
	FL101	393 8072 000	FL TUBE(15 BT 91GNK)		*
	JK201	269 0215 009	2P OPT/COAX JACK		*
	JK301	204 8668 004	8P PIN JACK (AU)		
	JK507	204 8674 001	2P MINI JACK(ST)		
	L901	235 0141 002	LINE FILTER (PLA10A)		
	L902	235 0142 917	COIL LHL08TB4R7MT		
	L903	239 8019 002	LINE FILTER COIL		
	L907	235 0142 917	COIL LHL08TB4R7MT		
	L908	235 0142 904	COIL LHL08TB220KT		
	L909	235 0142 917	COIL LHL08TB4R7MT		
⚠	S101 115	212 5604 910	TACT SWITCH TA(ALPS)		
	S901	212 1030 009	POWER SWITCH (TV 5)		
	ST101	205 0452 017	STYLE PIN		
	ST903	205 0452 017	STYLE PIN		
⚠	T201	231 8063 009	PULSE TRANS		
	T901	233 6403 007	SW TRANSFORMER(WIDE)		
	W102	203 0526 015	1P CONTACT ASS		
	W301	203 0717 002	1P SIN SIN WIRE		
		415 0866 006	CONDENSER COVER	1	
		417 0592 004	HEAT SINK	1	
		417 0610 009	HEAT SINK(OSH 2430)	1	
		461 0991 026	RUBBER SHEET	2	
		513 3827 003	FUSE LABEL	1	
		471 3303 016	3X6 CBS Z	1	
		471 3305 027	3X10 CBS	1	

GU-3572A VIDEO UNIT A

	Ref. No.	Part No.	Part Name	Remarks	New
SEMICONDUCTORS GROUP					
	IC603	262 1348 903	TC74HC123AF(TP1)		
	IC604	262 2519 906	SN74LV00APW EL2		
	IC605	262 1793 901	TC4W53F		
	IC701	262 3058 000	SII504CM208		
	IC702	262 2916 004	64M SDRAM(TSOP)		
	IC703	262 3059 902	PIC18LC242 I/SO TAPE		
	IC704	262 3050 008	ADV7300		
	IC705	262 3093 007	ADV7190		
	IC706,707	262 3020 902	BH7860FP E2		
	IC708 710	263 1082 903	TK15420MTL		
	IC711	262 1348 903	TC74HC123AF(TP1)		
	IC712	263 1110 901	PQ070XZ01ZP		
	IC713	263 1079 903	BA033FP		
	IC714	262 2977 904	BA18BC0FP E2		
	IC715	263 1079 903	BA033FP		
	TR701,702	271 0293 901	2SA1022 B		
	TR703	274 0163 904	2SD601A		
	TR704,705	271 0293 901	2SA1022 B		
	TR706	274 0163 904	2SD601A		
	TR707,708	271 0293 901	2SA1022 B		
	TR709,710	274 0163 904	2SD601A		
	TR711,712	271 0293 901	2SA1022 B		
	TR713 716	272 0125 904	2SB709A		
	TR723 725	269 0082 902	DTC114EKT96		
	TR726 728	269 0083 901	DTA114EKT96		
	D701 703	276 0717 903	1SS355 TE 17		
RESISTORS GROUP					
	R601,602	247 2003 989	RM73B 330JT		
	R603	247 2018 903	RM73B 0R0KT		
	R605	247 2018 903	RM73B 0R0KT		
	R607,608	247 2018 903	RM73B 0R0KT		
	R610 612	247 2018 903	RM73B 0R0KT		
	R613 617	247 2003 989	RM73B 330JT		
	R622 624	247 2018 903	RM73B 0R0KT		
	R625,626	247 2005 987	RM73B 221JT		
	R627 630	247 2018 903	RM73B 0R0KT		
	R633	247 2009 983	RM73B 103JT		
	R634	247 2018 903	RM73B 0R0KT		
	R635	247 2009 983	RM73B 103JT		
	R636 640	247 2018 903	RM73B 0R0KT		
	R641	247 2008 913	RM73B 202JT		
	R642	247 2007 943	RM73B 102JT		
	R650 652	247 2009 909	RM73B 472JT (1608)		
	R668	247 2018 903	RM73B 0R0KT		
	R701	247 2007 943	RM73B 102JT		
	R702 705	247 2018 903	RM73B 0R0KT		
	R706,707	247 2003 989	RM73B 330JT		
	R708	247 2009 983	RM73B 103JT		
	R709,710	247 2003 989	RM73B 330JT		
	R714,715	247 2018 903	RM73B 0R0KT		

	Ref. No.	Part No.	Part Name	Remarks	New
	R716	247 2003 989	RM73B 330JT		
	R717	247 2018 903	RM73B 0R0KT		
	R718	247 2009 909	RM73B 472JT (1608)		
	R720,721	247 2003 989	RM73B 330JT		
	R722	247 2007 943	RM73B 102JT		
	R723	247 2018 903	RM73B 0R0KT		
	R724	247 2014 965	RM73B 105JT		
	R725	247 2009 909	RM73B 472JT (1608)		
	R726 728	247 2008 926	RM73B 222JT		
	R729 731	247 2018 903	RM73B 0R0KT		
	R733,734	247 2018 903	RM73B 0R0KT		
	R735	247 2009 909	RM73B 472JT (1608)		
	R736,737	247 2003 989	RM73B 330JT		
	R738,739	247 2009 909	RM73B 472JT (1608)		
	R740	247 2008 926	RM73B 222JT		
	R741,742	247 2018 903	RM73B 0R0KT		
	R743	247 2009 909	RM73B 472JT (1608)		
	R744,745	247 2003 989	RM73B 330JT		
	R746,747	247 2018 903	RM73B 0R0KT		
	R753,754	247 2003 989	RM73B 330JT		
	R755 757	247 2018 903	RM73B 0R0KT		
	R758	247 2003 989	RM73B 330JT		
	R759	247 2009 909	RM73B 472JT (1608)		
	R760	247 2018 903	RM73B 0R0KT		
	R761,762	247 2003 989	RM73B 330JT		
	R763 766	247 2018 903	RM73B 0R0KT		
	R767	247 2003 989	RM73B 330JT		
	R771	247 2018 903	RM73B 0R0KT		
	R773	247 2007 943	RM73B 102JT		
	R774 776	247 2018 903	RM73B 0R0KT		
	R777	247 2005 987	RM73B 221JT		
	R780	247 2007 985	RM73B 152JT		
	R781	247 2006 960	RM73B 471JT		
	R785	247 2007 943	RM73B 102JT		
	R788	247 2007 901	RM73B 681JT		
	R789,790	247 2018 903	RM73B 0R0KT		
	R791,792	247 2005 987	RM73B 221JT		
	R793	247 2003 989	RM73B 330JT		
	R794	247 2007 943	RM73B 102JT		
	R795	247 2006 986	RM73B 561JT		
	R796	247 2009 983	RM73B 103JT		
	R797	247 2005 903	RM73B 101JT		
	R798	247 2008 926	RM73B 222JT		
	R799	247 2018 903	RM73B 0R0KT		
	R803,804	247 2018 903	RM73B 0R0KT		
	R805,806	247 2014 965	RM73B 105JT		
	R807	247 2009 983	RM73B 103JT		
	R808,809	247 2008 913	RM73B 202JT		
	R810,811	247 2005 987	RM73B 221JT		
	R812	247 2003 989	RM73B 330JT		
	R813	247 2007 943	RM73B 102JT		
	R814	247 2006 986	RM73B 561JT		
	R815	247 2009 983	RM73B 103JT		
	R816	247 2005 903	RM73B 101JT		
	R817	247 2008 926	RM73B 222JT		
	R818	247 2018 903	RM73B 0R0KT		
	R822,823	247 2018 903	RM73B 0R0KT		
	R824,825	247 2014 965	RM73B 105JT		
	R826	247 2009 983	RM73B 103JT		
	R827,828	247 2008 913	RM73B 202JT		
	R829,830	247 2005 987	RM73B 221JT		

	Ref. No.	Part No.	Part Name	Remarks	New
	R831	247 2003 989	RM73B 330JT		
	R832	247 2007 943	RM73B 102JT		
	R833	247 2006 986	RM73B 561JT		
	R834	247 2009 983	RM73B 103JT		
	R835	247 2005 903	RM73B 101JT		
	R836	247 2008 926	RM73B 222JT		
	R837	247 2018 903	RM73B 0R0KT		
	R841,842	247 2018 903	RM73B 0R0KT		
	R843,844	247 2014 965	RM73B 105JT		
	R845	247 2009 983	RM73B 103JT		
	R846,847	247 2008 913	RM73B 202JT		
	R850 852	247 2007 943	RM73B 102JT		
	R853,854	247 2018 903	RM73B 0R0KT		
	R855	247 2009 983	RM73B 103JT		
	R856	247 2018 903	RM73B 0R0KT		
	R857	247 2009 983	RM73B 103JT		
	R858	247 2007 985	RM73B 152JT		
	R859,860	247 2009 983	RM73B 103JT		
	R861 863	247 2009 909	RM73B 472JT (1608)		
	R870,871	247 2018 903	RM73B 0R0KT		
	R872,873	247 2009 909	RM73B 472JT (1608)		
	R877,878	247 2018 903	RM73B 0R0KT		
	R880,881	247 2018 903	RM73B 0R0KT		
	R882,883	247 2003 989	RM73B 330JT		
	R884,885	247 2018 903	RM73B 0R0KT		
	R886	247 2007 943	RM73B 102JT		
	R887 889	247 2018 903	RM73B 0R0KT		
	R890,891	247 2009 909	RM73B 472JT (1608)		
	R892 894	247 2018 903	RM73B 0R0KT		
	R895	247 2007 943	RM73B 102JT		
	R896	247 2005 987	RM73B 221JT		
	R898	247 2005 987	RM73B 221JT		
	R901	247 2005 974	RM73B 201JT		
	R906 910	247 2005 903	RM73B 101JT		
	R914,915	247 2005 903	RM73B 101JT		
	R916 920	247 2003 989	RM73B 330JT		
	R921 925	247 2007 943	RM73B 102JT		
	R926 933	247 2018 903	RM73B 0R0KT		
	R935,936	247 2004 975	RM73B 750JT		
	R937	247 2004 962	RM73B 680JT		
	R938 940	247 2018 903	RM73B 0R0KT		
	R947 949	247 2004 975	RM73B 750JT		
	R950 952	247 2018 903	RM73B 0R0KT		
	R957 961	247 2018 903	RM73B 0R0KT		
	R984,985	247 2018 903	RM73B 0R0KT		
	R988 995	247 2018 903	RM73B 0R0KT		
	R996,997	247 2009 909	RM73B 472JT (1608)		
	R998	247 2003 989	RM73B 330JT		
	RA601 604	247 9002 909	MNR14=330JE0AB		
	RA605 608	247 9007 920	MNR14=0R0JE0		
	RA701 712	247 9002 909	MNR14=330JE0AB		
	VR701 706	211 6148 906	V03PB471MT(RH03ADCS)		
	VR708	211 6138 903	V03PB102MT(RH03ADC)		
CAPACITORS GROUP					
	C608	257 0512 903	CK73F1E104ZT		

	Ref. No.	Part No.	Part Name	Remarks	New
	C616	257 0512 903	CK73F1E104ZT		
	C618,619	257 0509 929	CK73B1H102KT		
	C620 623	257 0512 903	CK73F1E104ZT		
	C701 707	257 0512 903	CK73F1E104ZT		
	C708	257 0511 904	CK73F1H103ZT		
	C709	257 0512 903	CK73F1E104ZT		
	C710	257 4012 917	CE67C1C220MT (RV2)		
	C711	257 0511 904	CK73F1H103ZT		
	C712	257 4011 905	CE67C0J101MT (RV2)		
	C713 715	257 0512 903	CK73F1E104ZT		
	C717 721	257 0512 903	CK73F1E104ZT		
	C723,724	257 0512 903	CK73F1E104ZT		
	C725,726	257 4011 905	CE67C0J101MT (RV2)		
	C727	257 0512 903	CK73F1E104ZT		
	C728	257 4011 905	CE67C0J101MT (RV2)		
	C729 738	257 0512 903	CK73F1E104ZT		
	C739	257 4011 905	CE67C0J101MT (RV2)		
	C742	257 0511 904	CK73F1H103ZT		
	C743	257 0512 903	CK73F1E104ZT		
	C745,746	257 4011 905	CE67C0J101MT (RV2)		
	C747,748	257 0512 903	CK73F1E104ZT		
	C749	257 4011 905	CE67C0J101MT (RV2)		
	C750	257 0512 903	CK73F1E104ZT		
	C752	257 0511 904	CK73F1H103ZT		
	C753	257 0512 903	CK73F1E104ZT		
	C755,756	257 0512 903	CK73F1E104ZT		
	C758	257 0509 903	CK73B1H821KT		
	C759	257 0512 903	CK73F1E104ZT		
	C760	257 4011 905	CE67C0J101MT (RV2)		
	C761	257 0510 921	CK73B1H392KT		
	C765,766	257 0512 903	CK73F1E104ZT		
	C768,769	257 0512 903	CK73F1E104ZT		
	C770 772	257 4011 905	CE67C0J101MT (RV2)		
	C776,777	257 0512 903	CK73F1E104ZT		
	C779,780	257 0512 903	CK73F1E104ZT		
	C781,782	257 4012 917	CE67C1C220MT (RV2)		
	C783	257 4012 904	CE67C1C100MT (RV2B55)		
	C787,788	257 0512 903	CK73F1E104ZT		
	C790,791	257 0512 903	CK73F1E104ZT		
	C792,793	257 4012 917	CE67C1C220MT (RV2)		
	C794	257 4012 904	CE67C1C100MT (RV2B55)		
	C795,796	257 0512 903	CK73F1E104ZT		
	C797,798	257 4011 905	CE67C0J101MT (RV2)		
	C799,800	257 0512 903	CK73F1E104ZT		
	C801	257 4011 905	CE67C0J101MT (RV2)		
	C802	257 0507 934	CC73CH1H221JT		
	C803	257 0512 903	CK73F1E104ZT		
	C804,805	257 0509 929	CK73B1H102KT		
	C806,807	257 0512 903	CK73F1E104ZT		
	C808	257 4011 905	CE67C0J101MT (RV2)		
	C809,810	257 0512 903	CK73F1E104ZT		
	C811,812	257 4011 905	CE67C0J101MT (RV2)		
	C813 815	257 0512 903	CK73F1E104ZT		
	C816	257 4012 917	CE67C1C220MT (RV2)		
	C817	257 0512 903	CK73F1E104ZT		
	C818	257 4012 917	CE67C1C220MT (RV2)		
	C819	257 0512 903	CK73F1E104ZT		
	C820	257 0511 904	CK73F1H103ZT		
	C823 832	257 0512 903	CK73F1E104ZT		
	C833	257 4011 905	CE67C0J101MT (RV2)		
	C834	257 0501 901	CK73B1H103KT (1608)		

	Ref. No.	Part No.	Part Name	Remarks	New
	C835,836	257 4012 920	CE67C1C470MT (RV2)		
	C837,838	257 0511 904	CK73F1H103ZT		
	C839	257 4011 905	CE67C0J101MT (RV2)		
	C840	257 0512 903	CK73F1E104ZT		
	C841	257 0504 995	CC73CH1H510JT		
	C843	257 0501 901	CK73B1H103KT (1608)		
	C844	254 4327 904	CE04W0J102MT(SMG)		
	C845	257 4011 905	CE67C0J101MT (RV2)		
	C846	254 4327 904	CE04W0J102MT(SMG)		
	C847	257 4011 905	CE67C0J101MT (RV2)		
	C848	254 4533 950	CE04W0J471MT SMG/RE3		
	C850 852	257 4012 920	CE67C1C470MT (RV2)		
	C853,854	257 0511 904	CK73F1H103ZT		
	C855	257 4011 905	CE67C0J101MT (RV2)		
	C856	257 0512 903	CK73F1E104ZT		
	C857	257 0504 995	CC73CH1H510JT		
	C861,862	254 4533 950	CE04W0J471MT SMG/RE3		
	C863	257 0512 903	CK73F1E104ZT		
	C864	257 0511 904	CK73F1H103ZT		
	C865	257 0509 929	CK73B1H102KT		
	C866	257 4011 905	CE67C0J101MT (RV2)		
	C867,868	257 0512 903	CK73F1E104ZT		
	C869	257 0511 904	CK73F1H103ZT		
	C870	257 0509 929	CK73B1H102KT		
	C873	257 0512 903	CK73F1E104ZT		
	C875 879	257 0512 903	CK73F1E104ZT		
OTHER PARTS GROUP					
	CY53	205 0343 058	5P CONN.BASE(KR PH)		
	CY101	205 0884 054	10P CON.BASE TUC P		
	CY331	205 1170 945	33P FFC BASE(FMNBMTT)		
	JK701	205 1272 005	1P S TERMINAL		*
	JK704	204 8677 008	4P PIN JACK(Y/B/R/V)		*
	L704,705	235 0125 905	INDUCTOR(FLC32C220K)		
	L710	235 0125 905	INDUCTOR(FLC32C220K)		
	L712	235 0149 907	LK1608R68K T		
	L713	235 0125 905	INDUCTOR(FLC32C220K)		
	L715	235 0149 907	LK1608R68K T		
	LF701	261 0163 908	ELB4B591N		
	LF702	261 0162 909	ELB4C582N		
	X702	399 0832 903	CSTCG20MOV51 R0		

GU-3343A SCART P.W.B.UNIT A

Ref. No.	Part No.	Part Name	Remarks	New
SEMICONDUCTORS GROUP				
IC851	262 1793 901	TC4W53F		
IC852	263 1115 906	NJM2267M (TE2)		
IC853	262 0707 901	TC4053BF (TAPE)		
IC854	262 2534 907	BA7660FS E2		
TR851 854	269 0082 902	DTC114EKT96		
TR855	269 0083 901	DTA114EKT96		
RESISTORS GROUP				
R851,852	247 2007 943	RM73B 102JT		
R853	247 2006 915	RM73B 271JT		
R854	247 2006 960	RM73B 471JT		
R855,856	247 2005 945	RM73B 151JT		
R857,858	247 2004 975	RM73B 750JT		
R859,860	247 2006 902	RM73B 331JT (1608)		
R861 863	247 2005 945	RM73B 151JT		
R864	247 2005 974	RM73B 201JT		
R865,866	247 2005 945	RM73B 151JT		
R867	247 2011 900	RM73B 333JT		
R868	247 2009 925	RM73B 562JT		
R869	247 2011 900	RM73B 333JT		
R870	247 2009 925	RM73B 562JT		
R871	247 2011 900	RM73B 333JT		
R872	247 2009 925	RM73B 562JT		
R873 875	247 2004 975	RM73B 750JT		
R876	247 2009 909	RM73B 472JT (1608)		
R877 880	247 2018 903	RM73B 0R0KT		
R884	247 2004 975	RM73B 750JT		
CAPACITORS GROUP				
C851,852	257 0506 951	CC73CH1H101JT		
C853	254 4299 964	CE04W1C470MT(SRE)		
C854,855	254 4300 963	CE04W0J101MT(SRE)		
C856 859	257 0512 903	CK73F1E104ZT		
C860,861	254 4300 963	CE04W0J101MT(SRE)		
C862	257 0512 903	CK73F1E104ZT		
C863	254 4300 963	CE04W0J101MT(SRE)		
C864,865	257 0512 903	CK73F1E104ZT		
C866 868	254 4299 964	CE04W1C470MT(SRE)		
C869	254 4300 963	CE04W0J101MT(SRE)		
C870	254 4299 919	CE04W1C220MT(SRE)		
C871	254 4300 963	CE04W0J101MT(SRE)		
C872	254 4299 919	CE04W1C220MT(SRE)		
C873	254 4300 963	CE04W0J101MT(SRE)		
C874	254 4299 919	CE04W1C220MT(SRE)		
C875	257 0512 903	CK73F1E104ZT		
C876	254 4300 963	CE04W0J101MT(SRE)		
C877,878	257 0512 903	CK73F1E104ZT		
C879	257 0511 904	CK73F1H103ZT		
C880	257 0509 929	CK73B1H102KT		

	Ref. No.	Part No.	Part Name	Remarks	New
	C884 887	247 2018 903	RM73B 0R0KT		
	C890 892	247 2018 903	RM73B 0R0KT		
	C896,897	257 0512 903	CK73F1E104ZT		
OTHER PARTS GROUP					
	CX52 CX101	205 0395 051 205 0885 053	5P CONN.BASE(RED)L 10P CON.SOCKET TUC P		
	FB851 856	235 0130 903	CHIP EMIFIL(11A121)		
	JK851	204 6649 009	RGB CONNECTOR		
	L851	235 0070 911	INDUCTOR(220)ST		
	W701	414 0903 005	SCART SHIELD PLATE		
		001 0231 005	1P WIRE	1	
		001 0231 018	1P WIRE	1	
		254 4538 955	CE04W1C221MT SMG/RE3	1	
		461 0415 007	RUBBER SHEET	1	

St (For Europe model)

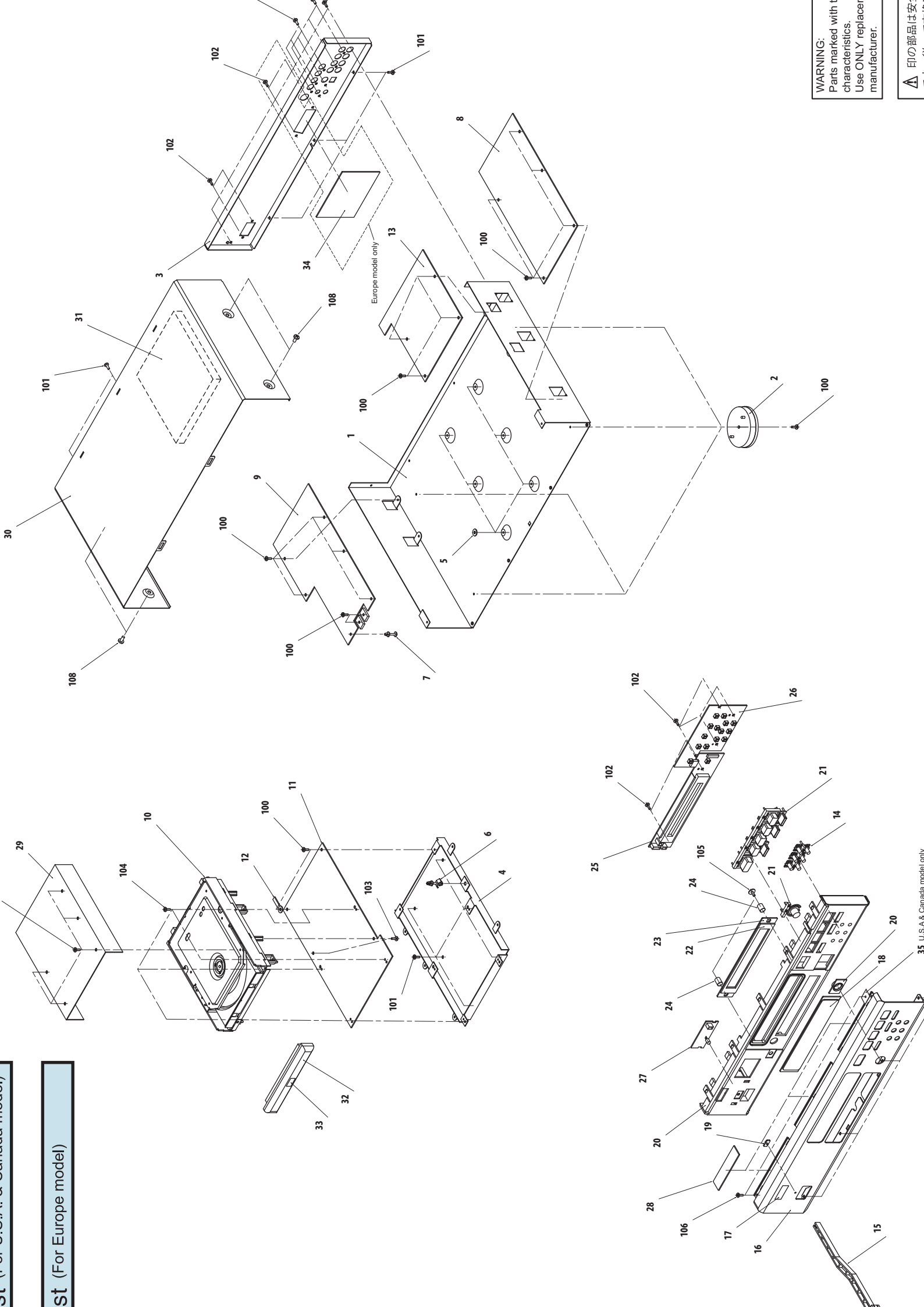

PARTS LIST OF EXPLODED VIEW (FOR U.S.A. & CANADA MODEL)

	Ref. No.	Part No.	Part Name	Remarks	Q'ty	New
		GU 3571	AUDIO/POW/DISP UNIT		1	
	8		AUDIO UNIT	GU 3571 1	1	
	9		POWER UNIT	GU 3571 2	1	
	25		DISPLAY UNIT	GU 3571 3	1	
	26		KEY UNIT	GU 3571 4	1	
	27		LED UNIT	GU 3571 5	1	
	11	GU 3570	MAIN UNIT		1	
	13	GU 3572	VIDEO UNIT		1	
	1	411 2039 208	CHASSIS		1	*
	2	104 0313 015	FOOT ASS'Y		4	
	3	105 1441 109	REAR PAENL		1	*
	4	411 2040 103	MECHA.FIX BRACKET		1	*
	5	449 0212 006	RUBBER WASHER		6	
	6	415 9016 064	P.C.B HOLDER		1	
	7	449 0050 064	CARD SPACER		1	
	10	337 0123 009	DVD MECHA(TD 5HP D1)		1	*
	12	445 0048 016	CORD HOLDER (L50)		1	
	14	113 1850 018	TACT KNOB (6P)		1	
	15	113 1974 211	P.SW.LEVER ASS'Y		1	*
	16	144 2855 016	FRONT PANEL ASS'Y		1	*
	17	131 0158 007	DENON BADGE		1	
	18	143 1178 102	WINDOW		1	*
	19	143 1110 005	LENS		1	
	20	146 2328 316	INNER PANEL		1	*
	21	113 1972 116	FUNCTION KNOB		1	*
	22	461 1164 001	BLIND CUSHION		1	*
	23	431 0437 000	BLIND		1	*
	24	463 0958 007	SPRING		2	*
	28	461 0501 005	RUBBER SHEET		3	
	29	412 5065 007	MECHA COVER		1	*
	30	102 0635 140	TOP COVER		1	*
	31	461 1168 023	RUBBER SHEET		1	
	32	146 2329 001	LOADER PANEL		1	*
	33	135 0065 008	DVD A/VIDEO PLATE		1	
	35	414 0595 031	EARTH PLATE		1	*
★		204 6610 012	12P PH PH CORD	CX121	1	
★		009 0226 098	13P FFC (1.0)	CX131	1	*
★		009 0226 069	27P FFC (1.0)	CX271	1	
★		009 0226 056	33P FFC (1.0)	CX331	1	
★		203 8489 031	5P PH PH CON CORD	CX51	1	*
★		203 6493 045	4P PH PH CONN.CORD	CX41	1	*
★		445 0033 005	WIRE CLAMP BAND		1	
★		009 0226 085	17P FFC (1.0)	CX171	1	*
★		513 1581 011	SERIAL NO. SHEET		1	
★		513 1381 004	MANUFAC.DATE LABEL		1	
SCREWS						
	100	473 7002 018	3X8 CBTS (S) Z		22	
	101	473 7015 005	3X6 CBTS(S) B		17	
	102	473 7500 044	3X8 CBTS (P) B		15	
	103	473 7506 019	2X6 CBTS (P) Z		2	
	104	473 7001 048	2.6X8 CBTS (S) Z		4	
	105	473 8044 004	SPECIAL SCREW		2	*
	106	473 7003 017	3X8 CFTS (S) B		2	

	Ref. No.	Part No.	Part Name	Remarks	Q'ty	New
	107	471 3301 018	3X4 CBS Z		5	
	108	477 0263 005	3P. SWELLING SCREW		4	

PARTS LIST OF EXPLODED VIEW (FOR EUROPE MODEL)

	Ref. No.	Part No.	Part Name	Remarks	Q'ty	New
	8	GU 3571A	AUD/POW/DISP UNIT A		1	
	9		AUDIO UNIT	GU 3571 1	1	
	25		POWER UNIT	GU 3571 2	1	
	26		DISPLAY UNIT	GU 3571 3	1	
	27		KEY UNIT	GU 3571 4	1	
	11	GU 3570	LED UNIT	GU 3571 5	1	
	13	GU 3572A	MAIN UNIT		1	
	34	GU 3343A	VIDEO UNIT A		1	
			SCART PWB UNIT A		1	
	1	411 2039 208	CHASSIS		1	*
	2	104 0313 015	FOOT ASS'Y	Gold & Black models	4	
	2	104 0313 028	FOOT ASS'Y	Silver model	4	
	3	105 1441 112	REAR PANEL	Gold & Black models	1	*
	3	105 1441 015	REAR PANEL	Silver model	1	*
	4	411 2040 103	MECHA.FIX BRACKET		1	*
	5	449 0212 006	RUBBER WASHER		6	
	6	415 9016 064	P.C.B HOLDER		1	
	7	449 0050 064	CARD SPACER		1	
	10	337 0123 009	DVD MECHA(TD 5HP D1)		1	*
	12	445 0048 016	CORD HOLDER (L50)		1	
	14	113 1850 005	TACT KNOB (6P)	Gold model	1	
	14	113 1850 018	TACT KNOB (6P)	Black model	1	
	14	113 1850 021	TACT KNOB (6P)	Silver model	1	*
	15	113 1974 208	P.SW.LEVER ASS'Y	Gold model	1	*
	15	113 1974 211	P.SW.LEVER ASS'Y	Black model	1	*
	15	113 1974 224	P.SW.LEVER ASS'Y	Silver model	1	*
	16	144 2855 003	FRONT PANEL ASS'Y	Gold model	1	*
	16	144 2855 016	FRONT PANEL ASS'Y	Black model	1	*
	16	144 2855 029	FRONT PANEL ASS'Y	Silver model	1	*
	17	131 0158 010	DENON BADGE	Gold model	1	
	17	131 0158 007	DENON BADGE	Black model	1	
	17	131 0158 023	DENON BADGE	Silver model	1	
	18	143 1178 102	WINDOW		1	*
	19	143 1110 005	LENS		1	
	20	146 2328 303	INNER PANEL	Gold model	1	*
	20	146 2328 316	INNER PANEL	Black model	1	*
	20	146 2328 329	INNER PANEL	Silver model	1	*
	21	113 1972 103	FUNCTION KNOB	Gold model	1	*
	21	113 1972 116	FUNCTION KNOB	Black model	1	*
	21	113 1972 129	FUNCTION KNOB	Silver model	1	*
	22	461 1164 001	BLIND CUSHION		1	*
	23	431 0437 000	BLIND		1	*
	24	463 0958 007	SPRING		2	*
	28	461 0501 005	RUBBER SHEET		3	
	29	412 5065 007	MECHA COVER		1	*
	30	102 0635 137	TOP COVER	Gold model	1	*
	30	102 0635 140	TOP COVER	Black model	1	*
	30	102 0635 153	TOP COVER	Silver model	1	*
	31	461 1168 023	RUBBER SHEET		1	
	32	146 2329 014	LOADER PANEL	Gold model	1	*
	32	146 2329 001	LOADER PANEL	Black model	1	*
	32	146 2329 027	LOADER PANEL	Silver model	1	*
	33	135 0065 011	DVD A/VIDEO PLATE	Gold model	1	
	33	135 0065 008	DVD A/VIDEO PLATE	Black model	1	
	33	135 0065 024	DVD A/VIDEO PLATE	Silver model	1	*
★		513 3463 001	LABEL(LASER)		1	
★		513 2065 002	E2 LASER CAUTION		1	

	Ref. No.	Part No.	Part Name	Remarks	Q'ty	New
★		204 6610 012	12P PH PH CORD	CX121	1	
★		009 0226 098	13P FFC (1.0)	CX131	1	*
★		009 0226 069	27P FFC (1.0)	CX271	1	
★		009 0226 056	33P FFC (1.0)	CX331	1	
★		203 8489 031	5P PH PH CON CORD	CX51	1	*
★		203 6493 045	4P PH PH CONN.CORD	CX41	1	*
★		445 0033 005	WIRE CLAMP BAND		1	
★		203 8489 044	5P PH PH CON CORD	CX54	1	*
★		009 0226 085	17P FFC (1.0)	CX171	1	*
★		513 1581 011	SERIAL NO. SHEET		1	
SCREWS						
	100	473 7002 018	3X8 CBTS (S) Z		22	
	101	473 7015 005	3X6 CBTS(S) B		17	
	102	473 7500 044	3X8 CBTS (P) B		17	
	103	473 7506 019	2X6 CBTS (P) Z		2	
	104	473 7001 048	2.6X8 CBTS (S) Z		4	
	105	473 8044 004	SPECIAL SCREW		2	*
	106	473 7003 017	3X8 CFTS (S) B		2	
	107	471 3301 018	3X4 CBS Z		5	
	108	477 0263 018	3P.SWELLING SCREW	Gold & Silver models	4	
	108	477 0263 005	3P. SWELLING SCREW	Black model	4	

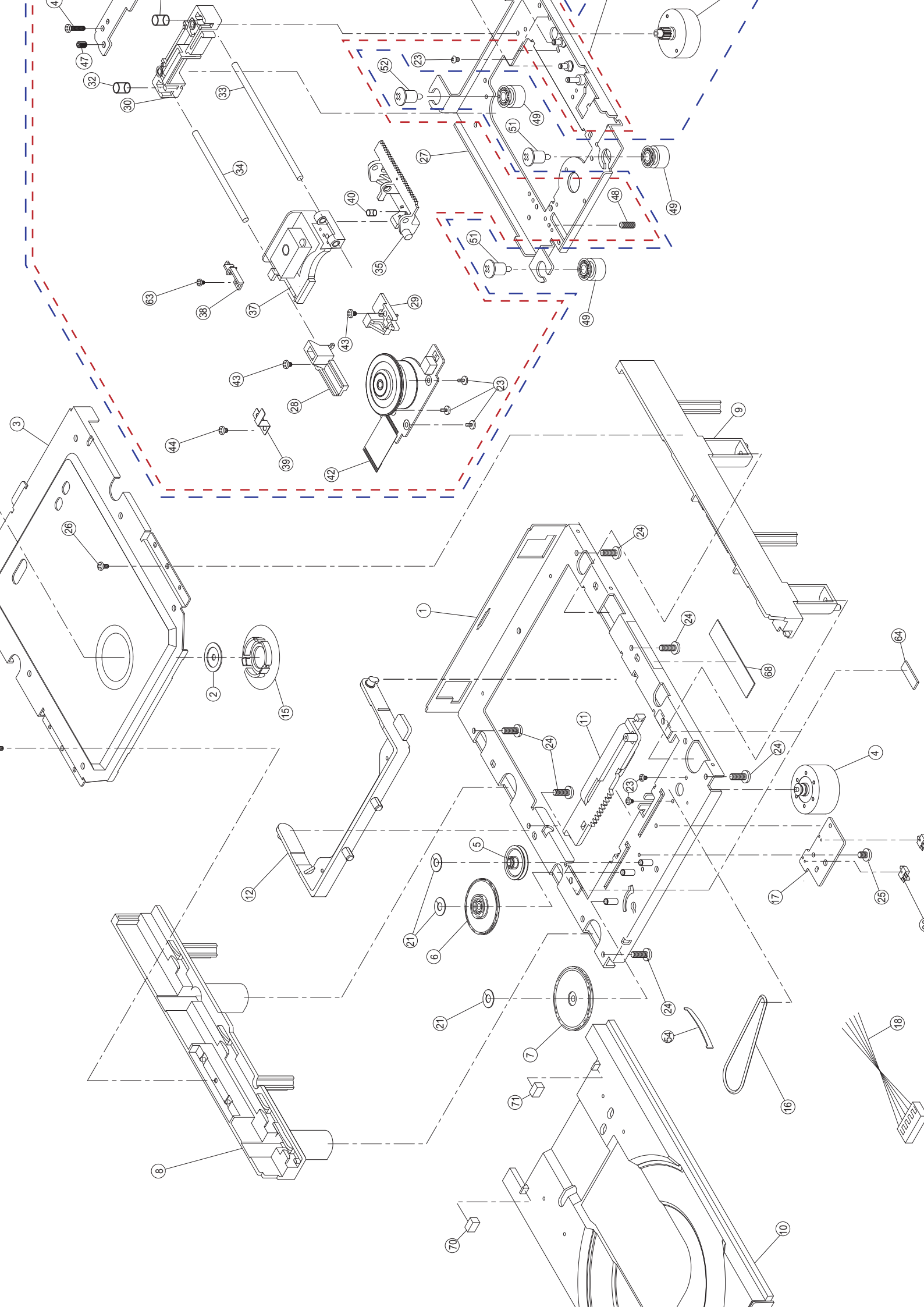

PARTS LIST OF DVD MECHANISM UNIT

3370123009 DVD MECHA (TD-5HP-D5)

Ref. No.	Part No.	Part Name	Remarks	Q'ty	New
1	9KC 1A01 7	MAIN CHASSIS ASS'Y		1	
2	9KA 7P08 5	CLAMPER BRACKET		1	
3	9KC 4P007F	GUIDE CLAMP BRACKET		1	
4	9KC 2A00 3	LOADING MOTOR ASS'Y		1	
5	9KC 2G02 9	LOADING GEAR		1	
6	9KB 9G03 0	LOADING GEAR 2ND		1	
7	9KB 9G03 1	LOADING GEAR 3RD		1	
8	9KA 2G41 7	SUB CHASSIS L		1	
9	9KA 2G41 8	SUB CHASSIS R		1	
10	9KA 2G399C	TRAY		1	
11	9KC 1G00 3	SLIDE CAM		1	
12	9KC 1G00 4	TRAVERSE ARM		1	
14	9KA 7G20 2	CLAMPER H		1	
15	9KA 7G20 3	CLAMPER L		1	
16	9KB 9G01 5	LOADING BELT		1	
17	9KC 1P01 4	SWITCH P.W.B.		1	
18	9KC 2G04 3	5P PH WIRE		1	
19	9KS 01W2 04	SWITCH ESE22MH21		1	
20	9KS 01W2 05	SWITCH ESE22MH23		1	
21	9KP 26C6 25	POLY.SLIT WASHER 2.6X6X0.25C		3	
22	445 8004 007	WIRE CLAMPER		1	
23	9KS 17N0 22	PRECISION SCREW 1.7X2.2 TYPE3		2	
24	9KB 26BK 06	SCREW 2.6X6 CBTS(B) Z		6	
25	9KS 20TK 33	PRECISION SCREW 2X3(S) TYPE3		1	
26	9KB 20PK 06	SCREW 2X6 CBTS(P) Z		2	
27A	9KC 2A06 3B	TRAVERSE MECHA (FEED) ASS'Y	Assembled part	1	
27B	9KC 2A06 4B	TRAVERSE MECHA ASS'Y	Assembled part	1	
23		PRECISION SCREW 1.7X2.2 TYPE3		3	
27		PU CHASSIS ASS'Y		1	
28		SHAFT HOLDER L		1	
29		SHAFT HOLDER R		1	
30		SHAFT TILT BASE		1	
31		SHAFT TILT PLATE		1	
32		TILT SPRING		2	
33		MAIN SHAFT		1	
34		SUB SHAFT		1	
35		PU RACK GEAR		1	
37		PICK UP HOP 1200R		1	
38		PU SPRING		1	
39		SHAFT SPRING		1	
40		RACK GEAR SPRING		1	
42		T/T MOTOR ASS'Y		1	
43		SCREW 2.6X6 CBTS(S) Z		2	
44		SCREW 2.6X4 CBTS(S) Z		1	
46		SCREW 2.6X15 CFTS(S) Z		2	
47		SCREW 3X4 BSS		2	
48		SCREW 3X8 BSS (A)		1	
63		PRECISION SCREW 1.7X5 TYPE3		1	
23		PRECISION SCREW 1.7X2.2 TYPE3		2	
36		FEED GEAR 2ND ASS'Y		1	
41		FEED MOTOR ASS'Y		1	
50		POLY.SLIT WASHER 2.1X4X0.25C		2	
53		FEED GEAR 3RD		1	
49	9KC 1G04 3	DAMPER		4	

Ref. No.	Part No.	Part Name	Remarks	Q'ty	New
51		SPECIAL SCREW (FRONT)		2	
52		SPECIAL SCREW (REAR)		2	
54	9KB 7P02 4	TRAY SPRING VXF		1	
64	9KC 1G04 2	RUBBER CUSHION		2	
68		TAPE W10X45 (NITTO NO.156)		1	
70	9KC 2G07 6	CUSHION L	6X3Xt4	1	
71	9KC 2G07 7	CUSHION R	6X3Xt2	1	

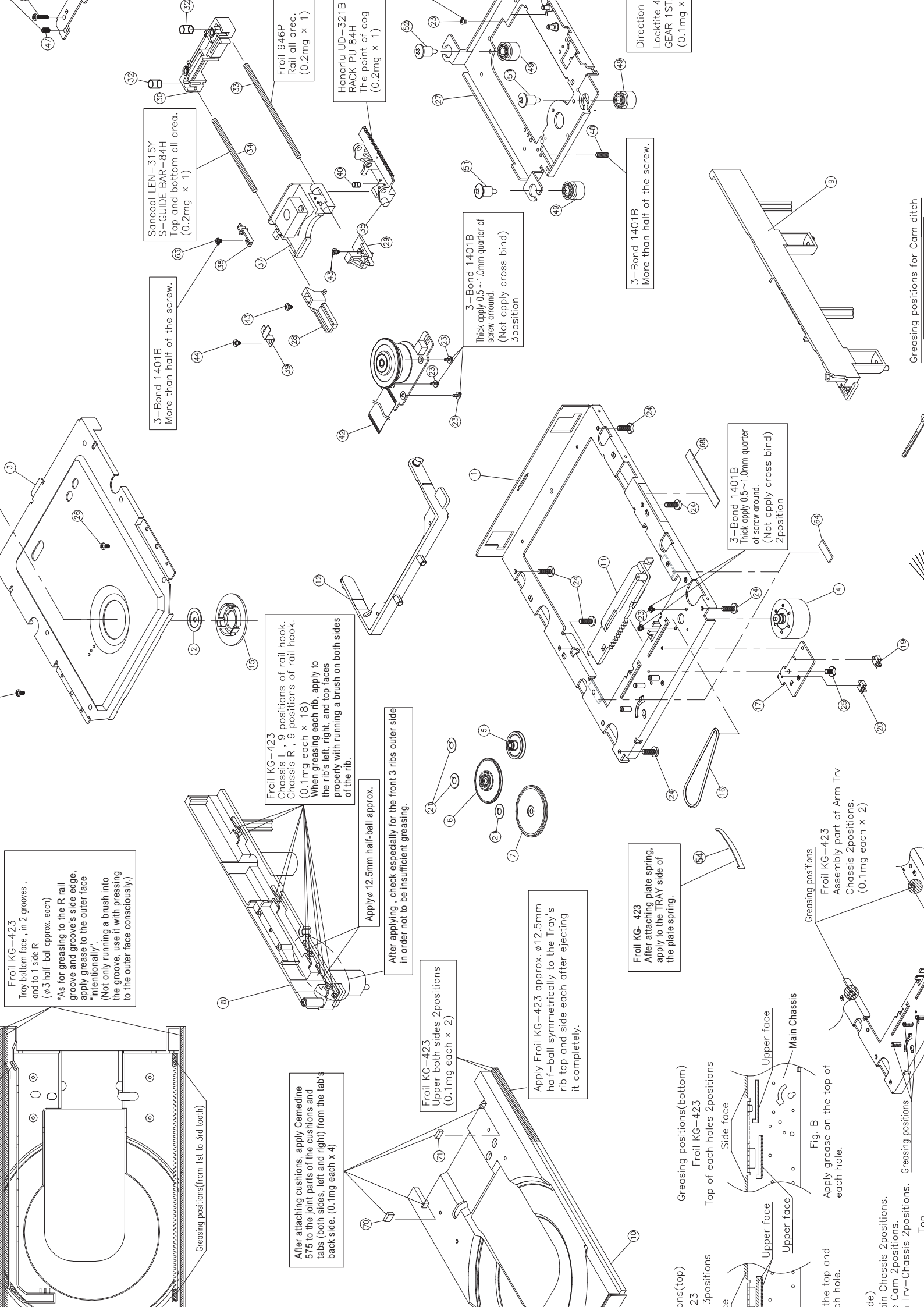

Froil KG-423
Tray bottom face, in 2 grooves,
and to 1 side R.
(ϕ 3 half-ball approx. each)
*As for greasing to the R rail
groove and groove's side edge,
apply grease to the outer face
"intentionally".
(Not only running a brush into
the groove, use it with pressing
to the outer face consciously.)

Sancoal LEN-315Y
S-GUIDE BAR-84H
Top and bottom all area.
(0.2mg x 1)

3-Bond 1401B
More than half of the screw.

Froil KG-423
Chassis L, 9 positions of rail hook.
Chassis R, 9 positions of rail hook.
(0.1mg each x 18).
When greasing each rib, apply to
the rib's left, right, and top faces
properly with running a brush on both sides
of the rib.

Apply ϕ 12.5mm half-ball approx.

After applying, check especially for the front 3 ribs outer side
in order not to be insufficient greasing.

Froil KG-423
Upper both sides 2positions
(0.1mg each x 2)

Apply Froil KG-423 approx. ϕ 12.5mm
half-ball symmetrically to the Tray's
rib top and side each after ejecting
it completely.

Froil KG-423
After attaching plate spring,
apply to the TRAY side of
the plate spring.

3-Bond 1401B
Thick apply 0.5~1.0mm quarter
of screw around.
(Not apply cross bind)
2position

3-Bond 1401B
Thick apply 0.5~1.0mm quarter of
screw around.
(Not apply cross bind)
3position

3-Bond 1401B
More than half of the screw.

After attaching cushions, apply Cemedine
575 to the joint parts of the cushions and
tabs (both sides, left and right) from the tabs
back side. (0.1mg each x 4)

Greasing positions
Froil KG-423
Assembly part of Arm Trv
Chassis 2positions.
(0.1mg each x 2)

Greasing positions(bottom)
Froil KG-423
Top of each holes 2positions

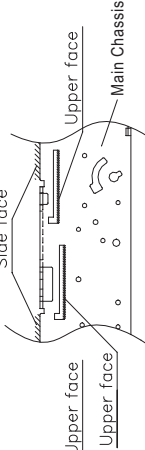

Fig. B
Apply grease on the top of
each hole.

the top and
each hole.

Greasing positions
in Chassis 2positions.
Cam 2positions.
Trv-Chassis 2positions.
Greasing positions
Ton

Greasing positions for Cam ditch

PACKING VIEW

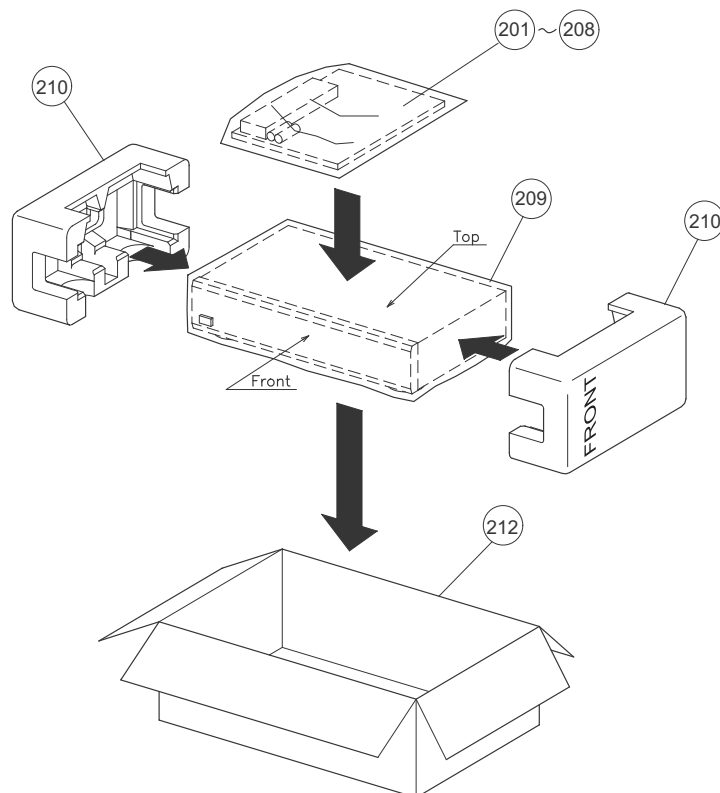

PARTS LIST OF PACKING & ACCESSORIES

Note : The symbols in the column "Remarks" indicate the following destinations.
 E3 : U.S.A. & Canada model E2 : Europe model

Ref. No.	Part No.	Part Name	Remarks	Q'ty	New	
	201	505 0038 043	POLY COVER		1	
	202	511 4096 002	INST. MANUAL	E3	1	*
	202	511 4097 001	INST. MANUAL(7)	E2	1	*
	204	515 0921 209	S.S.LIST(EX)		1	
⚠	205	206 2216 102	AC INLET N/I E3	E3	1	
⚠	205	206 2217 004	AC CONN WITH PLUG	E2	1	
	206	203 5224 008	3P PIN CORD		1	
	207	399 0902 008	RC 962		1	*
	208		BATTERY(UM 3)ASS'Y		1	
	209	505 0312 028	CABINET COVER		1	
	210	503 1472 000	CUSHION		2	*
	212	501 2250 005	CARTON CASE		1	*
★			CONT.CARD(L)		1	
★			UPC LABEL	E3	1	*
★			E2 POS LABEL	E2 Gold model	1	*
★			E2 POS LABEL	E2 Black model	1	*
★			E2 POS LABEL	E2 Silver model	1	*
★		513 3579 005	REGION LABEL(NO.1)	E3	2	
★		513 3579 018	REGION LABEL(NO.2)	E2	2	
★		515 0944 008	WARRANTY (HOME)	E3	1	
★		513 9111 001	COLOR LABEL (GOLD)	E2 Gold model	2	
★		513 9111 056	COLOR LABEL	E2 Silver model	2	

WIRING DIAGRAM

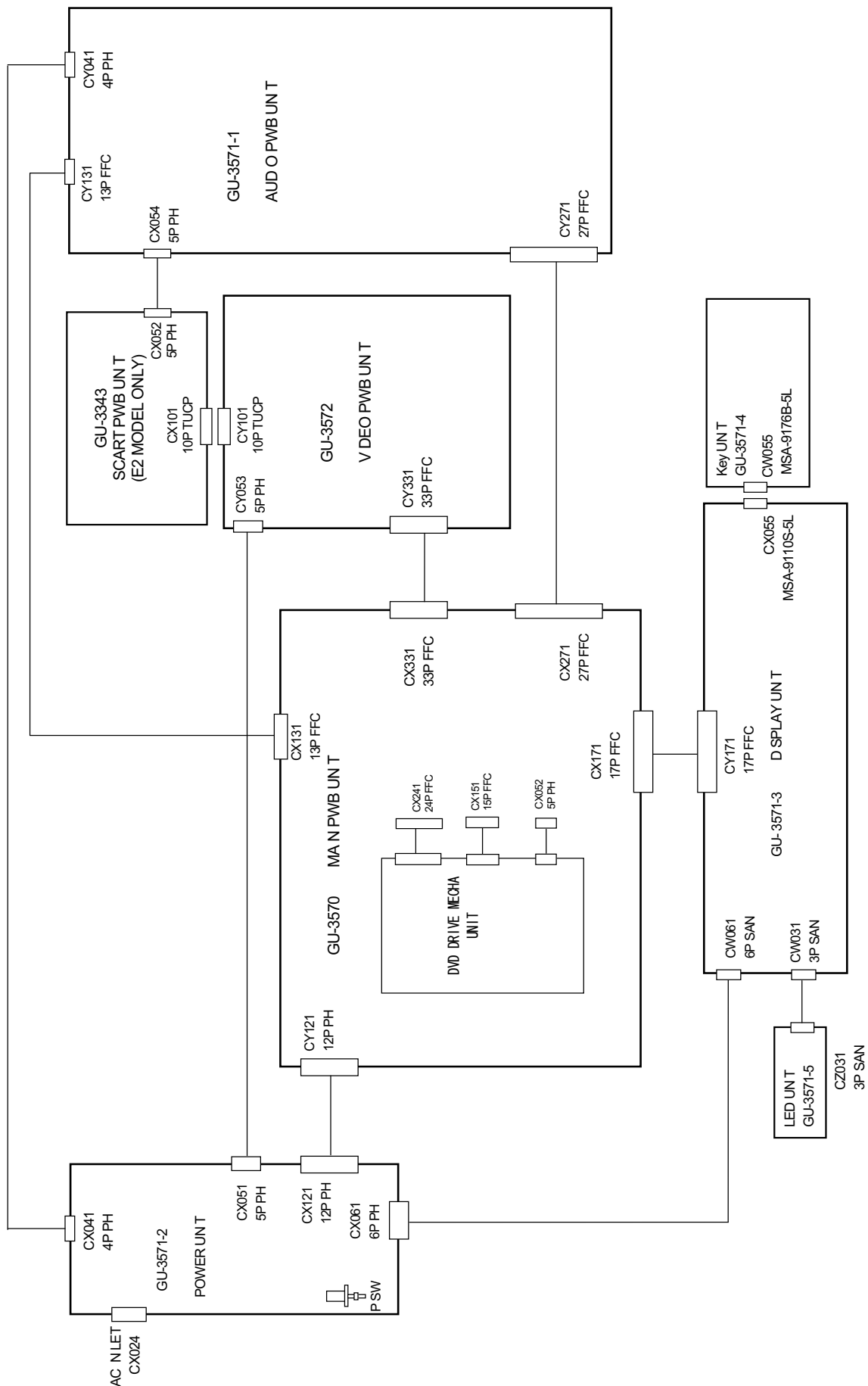

MEASURING METHOD AND WAVEFORMS 各部の波形と測定方法

To check the waveforms on the Main P.W.B., the GND (-) probe of the oscilloscope to "Vref" point.

NOTICE:

Measuring Disc: DVD/DVDT-S01 TDV-520A
CD/TC-784

(It is better to use wires for extending between the probe and test points.)

- When watching the HF waveform, use the extending wire as short as possible.
- When HF waveform is noisy or cannot discriminate the eye-pattern, replace the Traverse Unit after measuring the top.
- ① ~ ⑰ points have the certain test points shown below.

メイン基板の波形チェックを行なうためにはオシロスコプのGND(-)プローブを"Vref"ポイントに接続します

注)

測定ディスク：DVD/DVDT-S01 TDV-520A
CD/TC-784

(テストポイントとプローブ間に延長ワイヤを使用するのがより良い方法です。)

- HF 波形を観測する場合、できるだけ短い延長ワイヤを使用してください。
- HF 波形がノイズで不明瞭、またはアイパターンが識別不能の場合は 1op 測定後にトラバースユニットを交換してください。
- ポイントは①~⑰は、下図のように特定テストポイント付きです。

GU-3570 Main P.W.B. Unit Foil Side

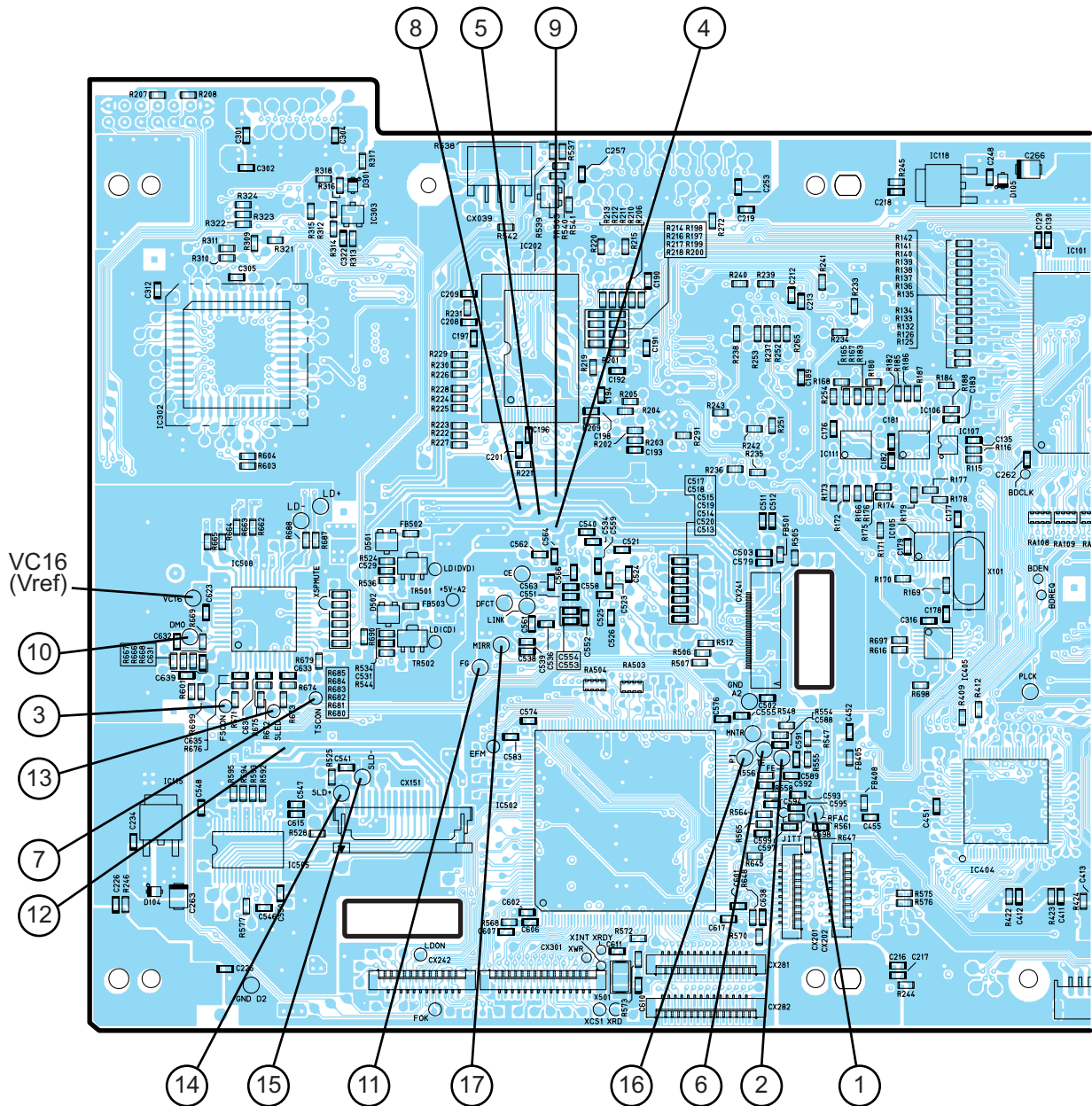

WAVEFORMS

• GU-3570 MAIN P.W.B.

DVD PLAY

Disc: TDV-520A

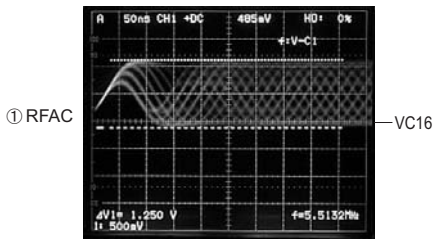

CD PLAY

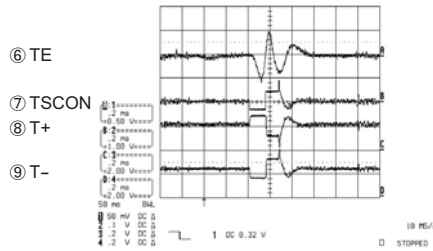

DISC DETECT (CD)

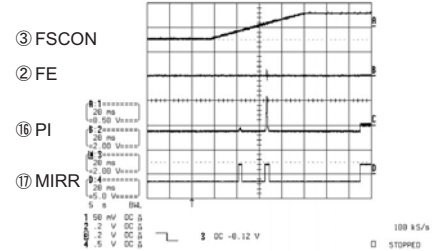

CD PLAY

Disc: TCD-784

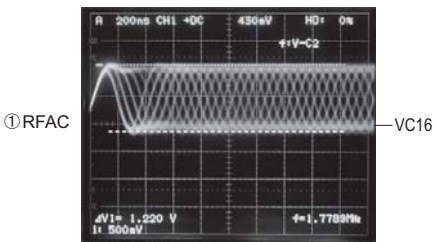

DVD PLAY (INNER)

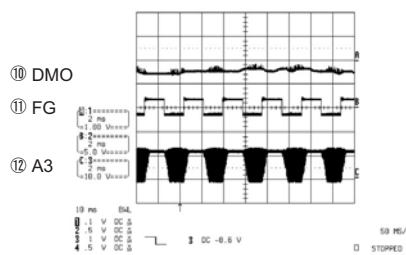

DVD LOADING → PLAY

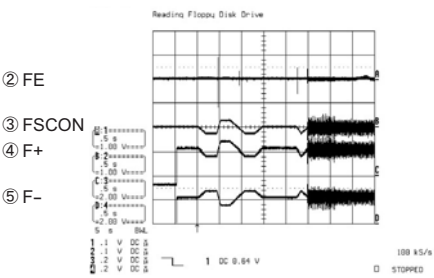

CD PLAY (INNER)

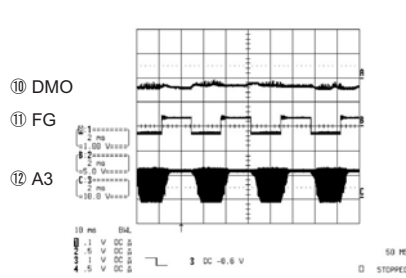

CD LOADING → PLAY

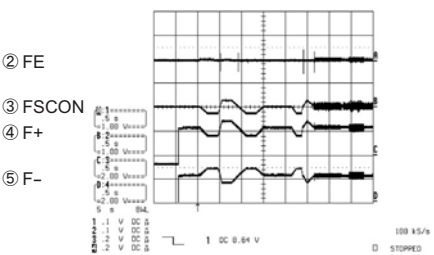

SEARCH TO OUTER CHAPTER (INNER → OUTER)

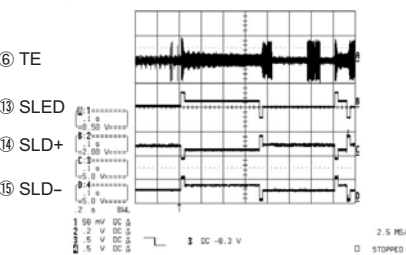

DVD PLAY

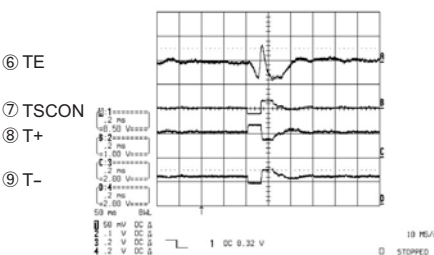

DISC DETECT (DVD)

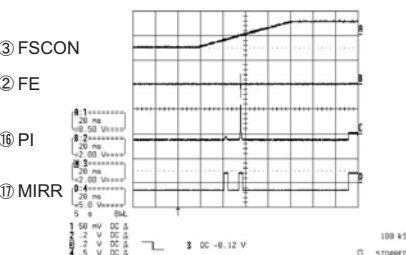

• GU-3571-2 POWER P.W.B

• GU-3572 VIDEO P.W.B

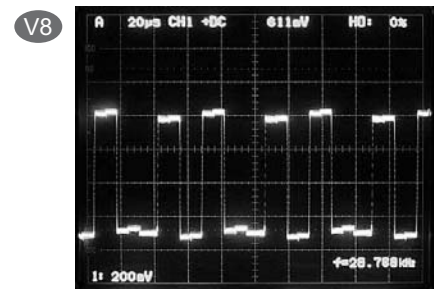
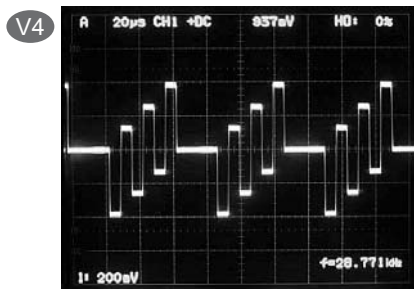
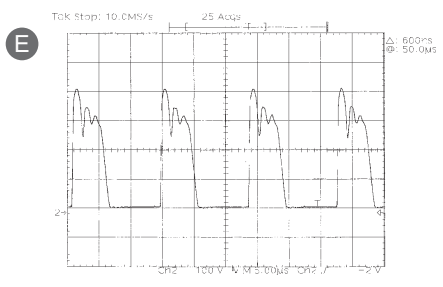
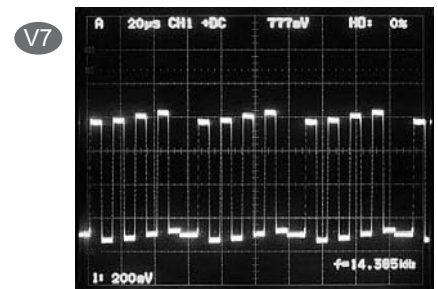
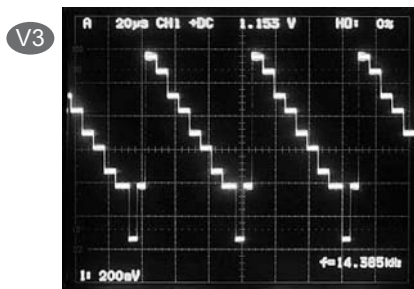
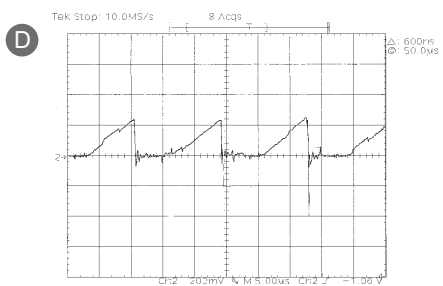
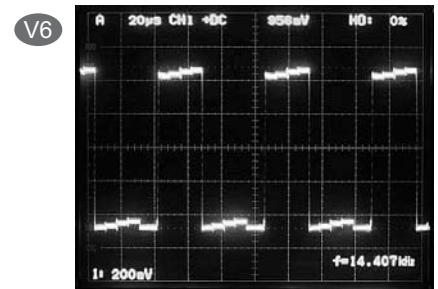
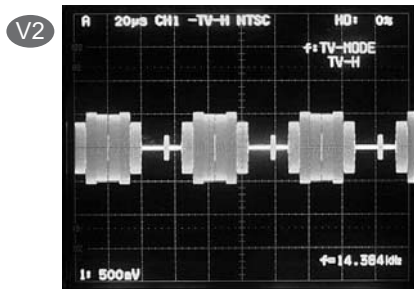
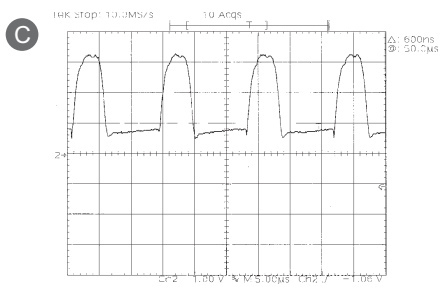
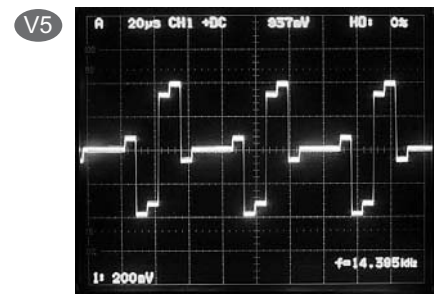
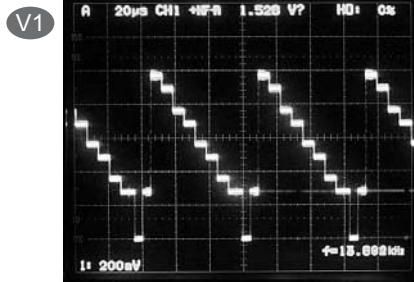
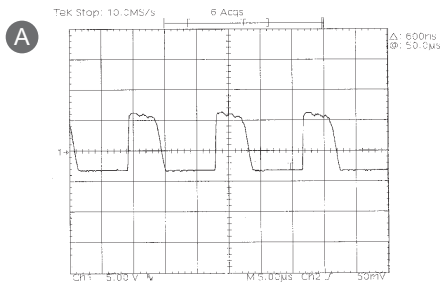

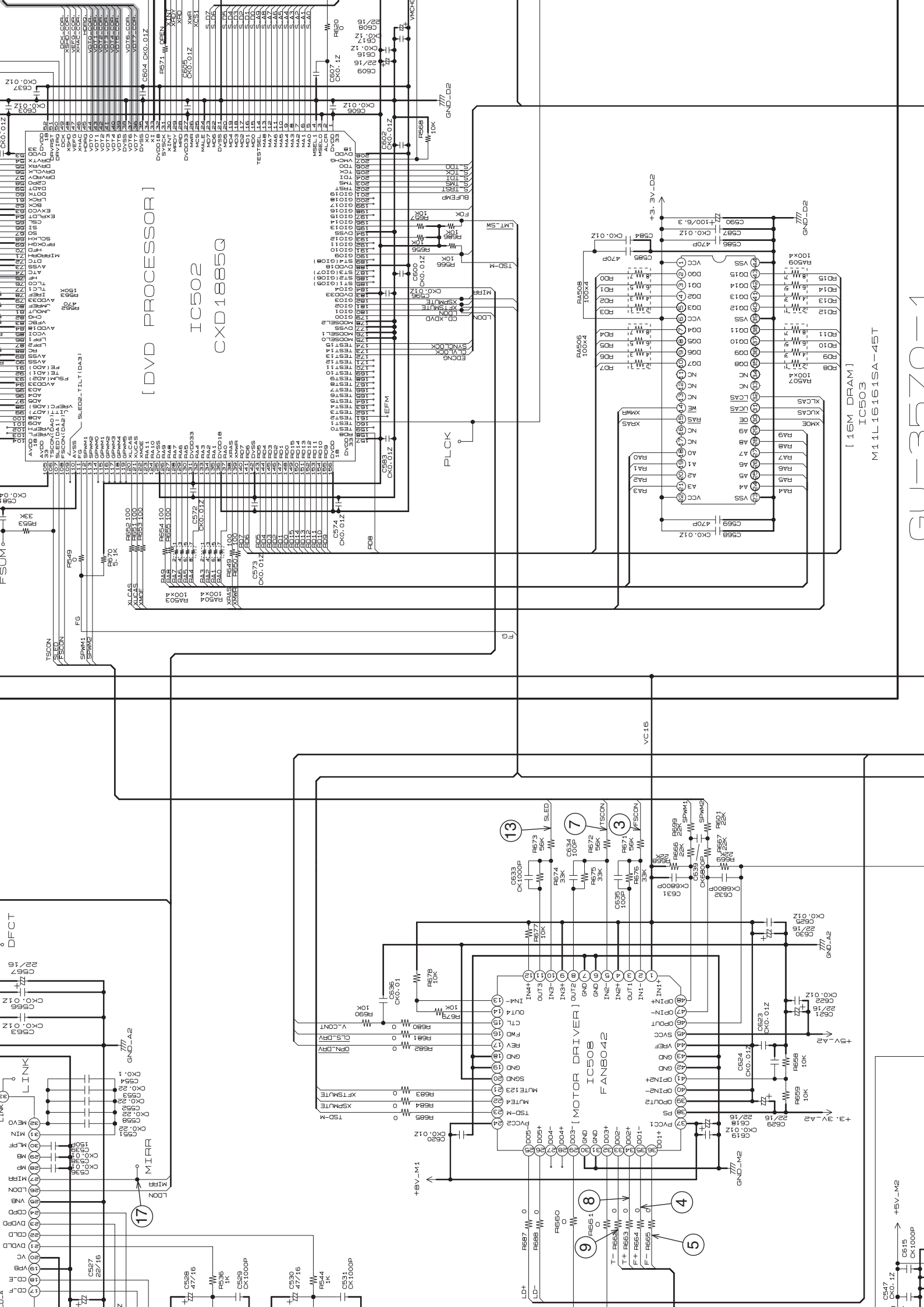

[DVD PROCESSOR]

IC502
CXD1885G

[16M DRAM]

IC503
M11L16161SA-45T

[MOTOR DRIVER]
IC508
FAN042

17

13

7

3

8

4

5

547

CK0.1Z

+5V_M2

515

CK1000P

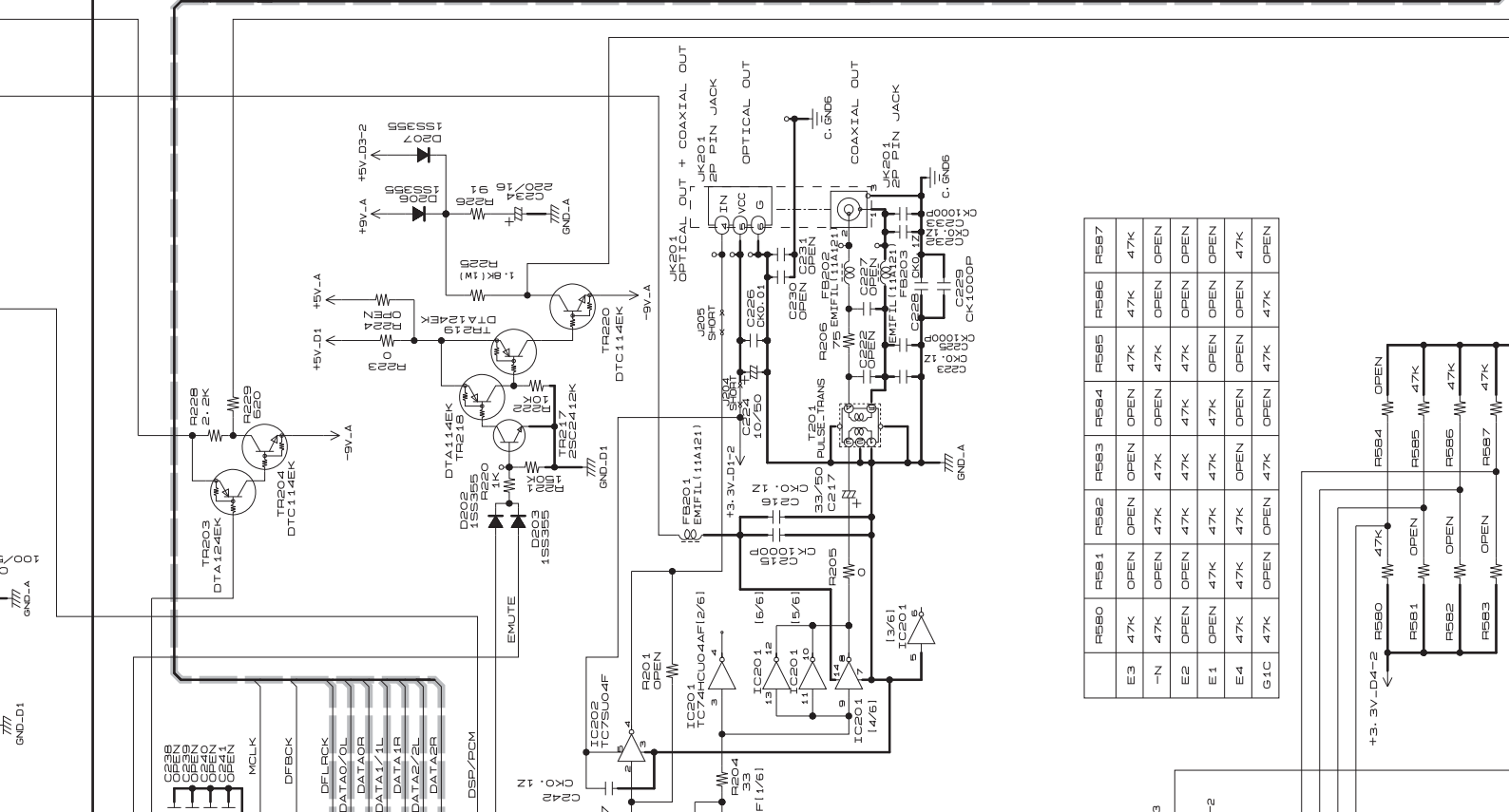
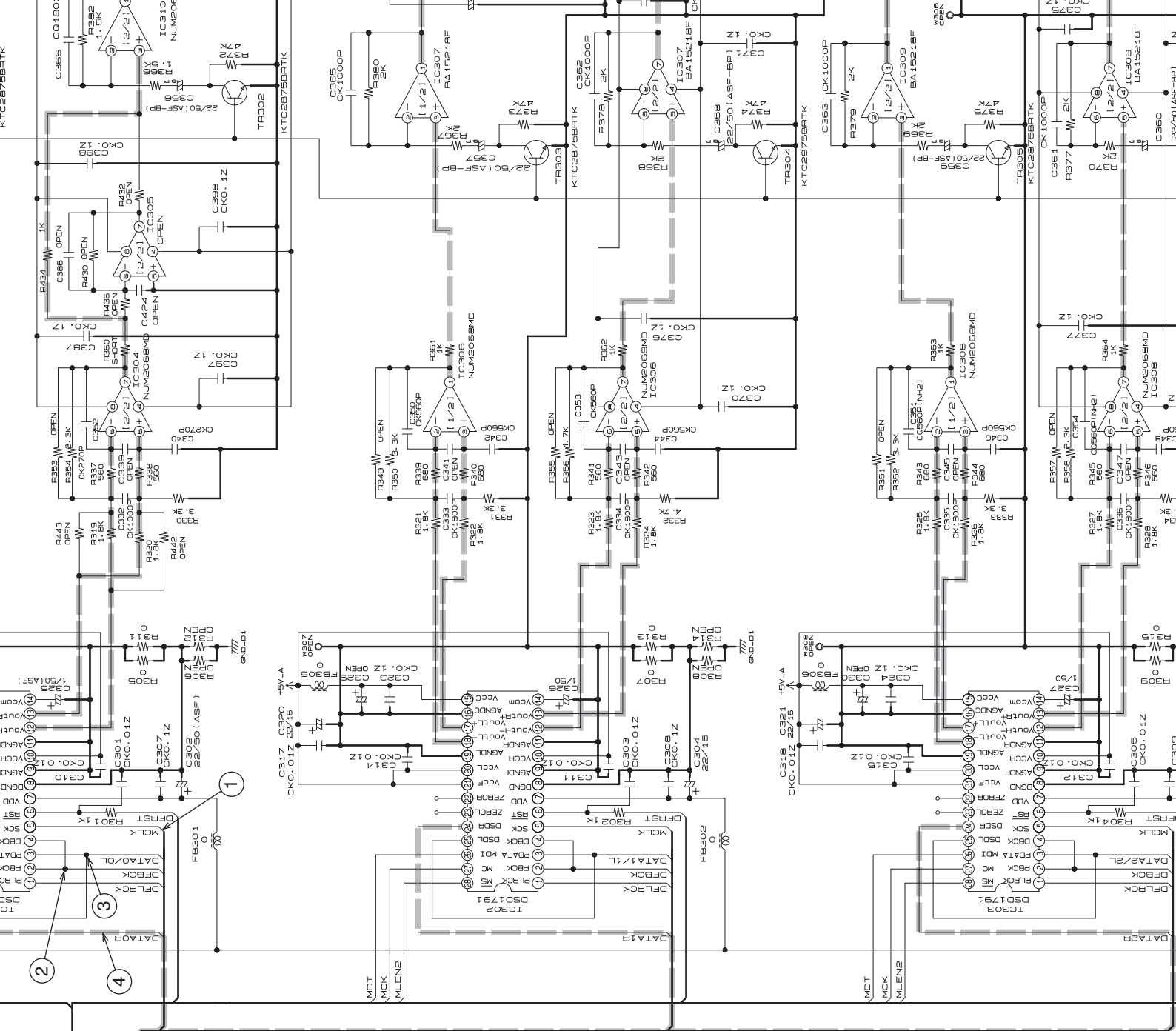

	R680	R681	R682	R683	R684	R685	R686	R687
E3	47K	OPEN	OPEN	OPEN	OPEN	47K	47K	47K
-N	47K	OPEN	47K	47K	47K	47K	OPEN	OPEN
E2	OPEN	OPEN	47K	47K	47K	47K	OPEN	OPEN
E1	OPEN	47K	47K	47K	47K	47K	OPEN	OPEN
E4	47K	47K	47K	47K	47K	47K	OPEN	47K
G1C	47K	OPEN	OPEN	OPEN	OPEN	OPEN	OPEN	OPEN

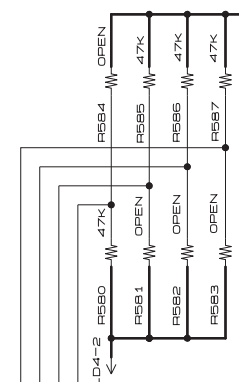

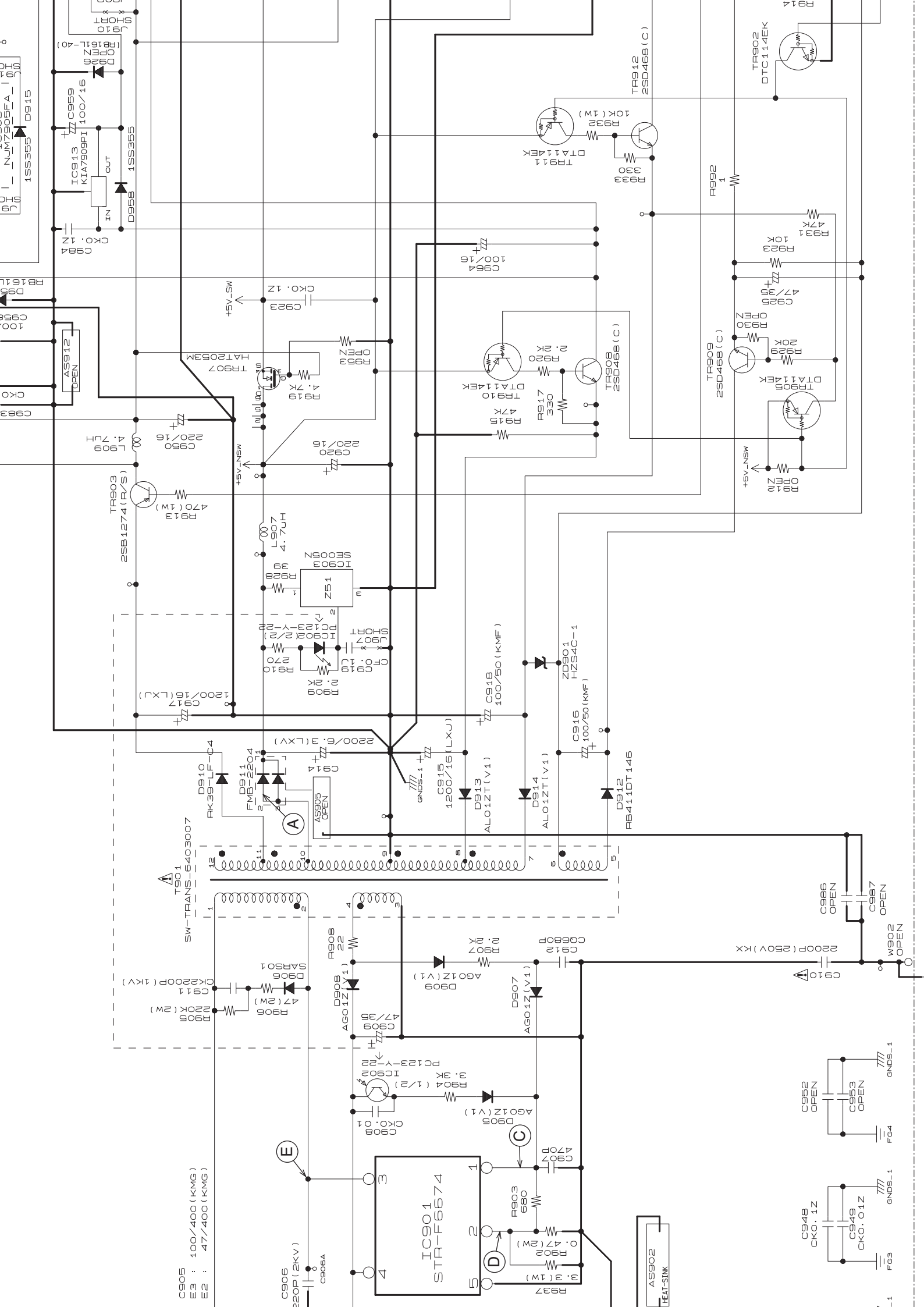

C905
E3 : 100/400 (KMG)
E2 : 477/400 (KMG)

(E)

C906
220P (2KV)
C906A

IC901
STR-F6674

(D)

(C)

(A)

(B)

(C)

(D)

(E)

(F)

(G)

(H)

(I)

(J)

(K)

(L)

(M)

(N)

(O)

(P)

(Q)

(R)

(S)

(T)

(U)

(V)

(W)

(X)

(Y)

(Z)

(AA)

(AB)

(AC)

(AD)

(AE)

(AF)

(AG)

(AH)

(AI)

(AJ)

(AK)

(AL)

(AM)

(AN)

(AO)

(AP)

(AQ)

(AR)

(AS)

(AT)

(AU)

(AV)

(AW)

(AX)

(AY)

(AZ)

(BA)

(BB)

(BC)

(BD)

(BE)

(BF)

(BG)

(BH)

(BI)

(BJ)

(BK)

(BL)

(BM)

(BN)

(BO)

(BP)

(BQ)

(BR)

(BS)

(BT)

(BU)

(BV)

(BW)

(BX)

(BY)

(BZ)

(CA)

(CB)

(CC)

(CD)

(CE)

(CF)

(CG)

(CH)

(CI)

(CJ)

(CK)

(CL)

(CM)

(CN)

(CO)

(CP)

(CQ)

(CR)

(CS)

(CT)

(CU)

(CV)

(CW)

(CX)

(CY)

(CZ)

(DA)

(DB)

(DC)

(DD)

(DE)

(DF)

(DG)

(DH)

(DI)

(DJ)

(DK)

(DL)

(DM)

(DN)

(DO)

(DP)

(DQ)

(DR)

(DS)

(DT)

(DU)

(DV)

(DW)

(DX)

(DY)

(DZ)

(EA)

(EB)

(EC)

(ED)

(EE)

(EF)

(EG)

(EH)

(EI)

(EJ)

(EK)

(EL)

(EM)

(EN)

(EO)

(EP)

(EQ)

(ER)

(ES)

(ET)

(EU)

(EV)

(EW)

(EX)

(EY)

(EZ)

(FA)

(FB)

(FC)

(FD)

(FE)

(FF)

(FG)

(FH)

(FI)

(FJ)

(FK)

(FL)

(FM)

(FN)

(FO)

(FP)

(FQ)

(FR)

(FS)

(FT)

(FU)

(FV)

(FW)

(FX)

(FY)

(FZ)

(GA)

(GB)

(GC)

(GD)

(GE)

(GF)

(GG)

(GH)

(GI)

(GJ)

(GK)

(GL)

(GM)

(GN)

(GO)

(GP)

(GQ)

(GR)

(GS)

(GT)

(GU)

(GV)

(GW)

(GX)

(GY)

(GZ)

(HA)

(HB)

(HC)

(HD)

(HE)

(HF)

(HG)

(HH)

(HI)

(HJ)

(HK)

(HL)

(HM)

(HN)

(HO)

(HP)

(HQ)

(HR)

(HS)

(HT)

(HU)

(HV)

(HW)

(HX)

(HY)

(HZ)

(IA)

(IB)

(IC)

(ID)

(IE)

(IF)

(IG)

(IH)

(II)

(IJ)

(IK)

(IL)

(IM)

(IN)

(IO)

(IP)

(IQ)

(IR)

(IS)

(IT)

(IU)

(IV)

(IW)

(IX)

(IY)

(IZ)

(JA)

(JB)

(JC)

(JD)

(JE)

(JF)

(JG)

(JH)

(JI)

(JJ)

(JK)

(JL)

(JM)

(JN)

(JO)

(JP)

(JQ)

(JR)

(JS)

(JT)

(JU)

(JV)

(JW)

(JX)

(JY)

(JZ)

(KA)

(KB)

(KC)

(KD)

(KE)

(KF)

(KG)

(KH)

(KI)

(KJ)

(KK)

(KL)

(KM)

(KN)

(KO)

(KP)

(KQ)

(KR)

(KS)

(KT)

(KU)

(KV)

(KW)

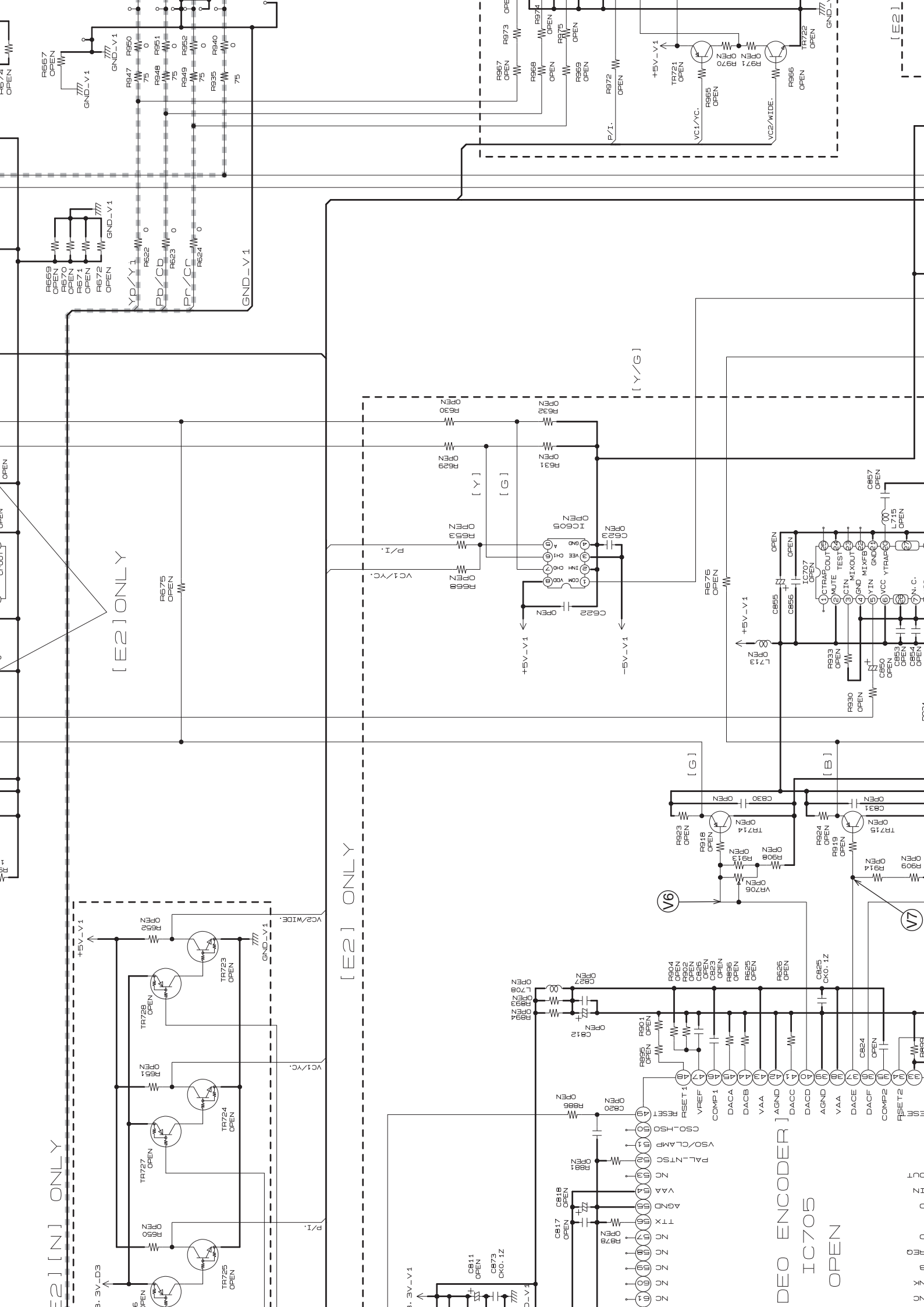

[E2] [N] ONLY

[E2] ONLY

[E2] ONLY

[Y/G]

[G]

[B]

DEO ENCODER
IC705
OPEN

[E2]

OPEN

3.3V-D3

TR725 OPEN

TR727 OPEN

TR724 OPEN

TR728 OPEN

TR723 OPEN

R669 OPEN
R670 OPEN
R671 OPEN
R672 OPEN
GND-V1

Y/P/Y1

Pb/Cb

Pr/Cc

GND-V1

R667 OPEN
GND-V1

GND-V1

R647 OPEN

R648 OPEN

R649 OPEN

R635 OPEN

R636 OPEN

3.3V-V1

GND-V1

CB811 OPEN

CB873 CKO.1Z

CB874 CKO.1Z

CB875 CKO.1Z

CB876 CKO.1Z

CB877 CKO.1Z

CB878 CKO.1Z

CB879 CKO.1Z

CB880 CKO.1Z

CB881 CKO.1Z

CB882 CKO.1Z

CB883 CKO.1Z

CB884 CKO.1Z

CB885 CKO.1Z

CB817 OPEN

CB818 OPEN

CB819 OPEN

CB820 OPEN

CB821 OPEN

CB822 OPEN

CB823 OPEN

CB824 OPEN

CB825 OPEN

CB826 OPEN

CB827 OPEN

CB828 OPEN

CB829 OPEN

CB830 OPEN

CB831 OPEN

CB832 OPEN

CB833 OPEN

CB834 OPEN

CB835 OPEN

CB836 OPEN

CB837 OPEN

CB838 OPEN

CB839 OPEN

CB840 OPEN

CB841 OPEN

CB842 OPEN

CB843 OPEN

CB844 OPEN

CB845 OPEN

CB846 OPEN

CB847 OPEN

CB848 OPEN

CB849 OPEN

CB850 OPEN

CB851 OPEN

CB852 OPEN

CB853 OPEN

CB854 OPEN

CB855 OPEN

CB856 OPEN

CB857 OPEN

CB858 OPEN

CB859 OPEN

CB860 OPEN

CB861 OPEN

CB862 OPEN

CB863 OPEN

CB864 OPEN

CB865 OPEN

CB866 OPEN

CB867 OPEN

CB868 OPEN

CB869 OPEN

CB870 OPEN

CB871 OPEN

CB872 OPEN

CB873 OPEN

CB874 OPEN

CB875 OPEN

CB876 OPEN

CB877 OPEN

CB878 OPEN

CB879 OPEN

CB880 OPEN

CB881 OPEN

CB882 OPEN

CB883 OPEN

CB884 OPEN

CB885 OPEN

CB886 OPEN

CB887 OPEN

CB888 OPEN

CB889 OPEN

CB890 OPEN

CB891 OPEN

CB892 OPEN

CB893 OPEN

CB894 OPEN

CB895 OPEN

CB896 OPEN

CB897 OPEN

CB898 OPEN

CB899 OPEN

CB900 OPEN

CB901 OPEN

CB902 OPEN

CB903 OPEN

CB904 OPEN

CB905 OPEN

CB906 OPEN

CB907 OPEN

CB908 OPEN

CB909 OPEN

CB910 OPEN

CB911 OPEN

CB912 OPEN

CB913 OPEN

CB914 OPEN

CB915 OPEN

CB916 OPEN

CB917 OPEN

CB918 OPEN

CB919 OPEN

CB920 OPEN

CB921 OPEN

CB922 OPEN

CB923 OPEN

CB924 OPEN

CB925 OPEN

CB926 OPEN

CB927 OPEN

CB928 OPEN

CB929 OPEN

CB930 OPEN

CB931 OPEN

CB932 OPEN

CB933 OPEN

CB934 OPEN

CB935 OPEN

CB936 OPEN

CB937 OPEN

CB938 OPEN

CB939 OPEN

CB940 OPEN

CB941 OPEN

CB942 OPEN

CB943 OPEN

CB944 OPEN

CB945 OPEN

CB946 OPEN

CB947 OPEN

CB948 OPEN

CB949 OPEN

CB950 OPEN

CB951 OPEN

CB952 OPEN

CB953 OPEN

CB954 OPEN

CB955 OPEN

CB956 OPEN

CB957 OPEN

CB958 OPEN

CB959 OPEN

CB960 OPEN

CB961 OPEN

CB962 OPEN

CB963 OPEN

CB964 OPEN

CB965 OPEN

CB966 OPEN

CB967 OPEN

CB968 OPEN

CB969 OPEN

CB970 OPEN

CB971 OPEN

CB972 OPEN

CB973 OPEN

CB974 OPEN

CB975 OPEN

CB976 OPEN

CB977 OPEN

CB978 OPEN

CB979 OPEN

CB980 OPEN

CB981 OPEN

CB982 OPEN

CB983 OPEN

CB984 OPEN

CB985 OPEN

CB986 OPEN

CB987 OPEN

CB988 OPEN

CB989 OPEN

CB990 OPEN

CB991 OPEN

CB992 OPEN

CB993 OPEN

CB994 OPEN

CB995 OPEN

CB996 OPEN

CB997 OPEN

CB998 OPEN

CB999 OPEN

CB1000 OPEN

CB1001 OPEN

CB1002 OPEN

CB1003 OPEN

CB1004 OPEN

CB1005 OPEN

CB1006 OPEN

CB1007 OPEN

CB1008 OPEN

CB1009 OPEN

CB1010 OPEN

CB1011 OPEN

CB1012 OPEN

CB1013 OPEN

CB1014 OPEN

CB1015 OPEN

CB1016 OPEN

CB1017 OPEN

CB1018 OPEN

CB1019 OPEN

CB1020 OPEN

CB1021 OPEN

CB1022 OPEN

CB1023 OPEN

CB1024 OPEN

CB1025 OPEN

CB1026 OPEN

CB1027 OPEN

CB1028 OPEN

CB1029 OPEN

CB1030 OPEN

CB1031 OPEN

CB1032 OPEN

CB1033 OPEN

CB1034 OPEN

CB1035 OPEN

CB1036 OPEN

CB1037 OPEN

CB1038 OPEN

CB1039 OPEN

CB1040 OPEN

CB1041 OPEN

CB1042 OPEN

CB1043 OPEN

CB1044 OPEN

CB1045 OPEN

CB1046 OPEN

CB1047 OPEN

CB1048 OPEN

CB1049 OPEN

CB1050 OPEN

CB1051 OPEN

CB1052 OPEN

CB1053 OPEN

CB1054 OPEN

CB1055 OPEN

CB1056 OPEN

CB1057 OPEN

CB1058 OPEN

CB1059 OPEN

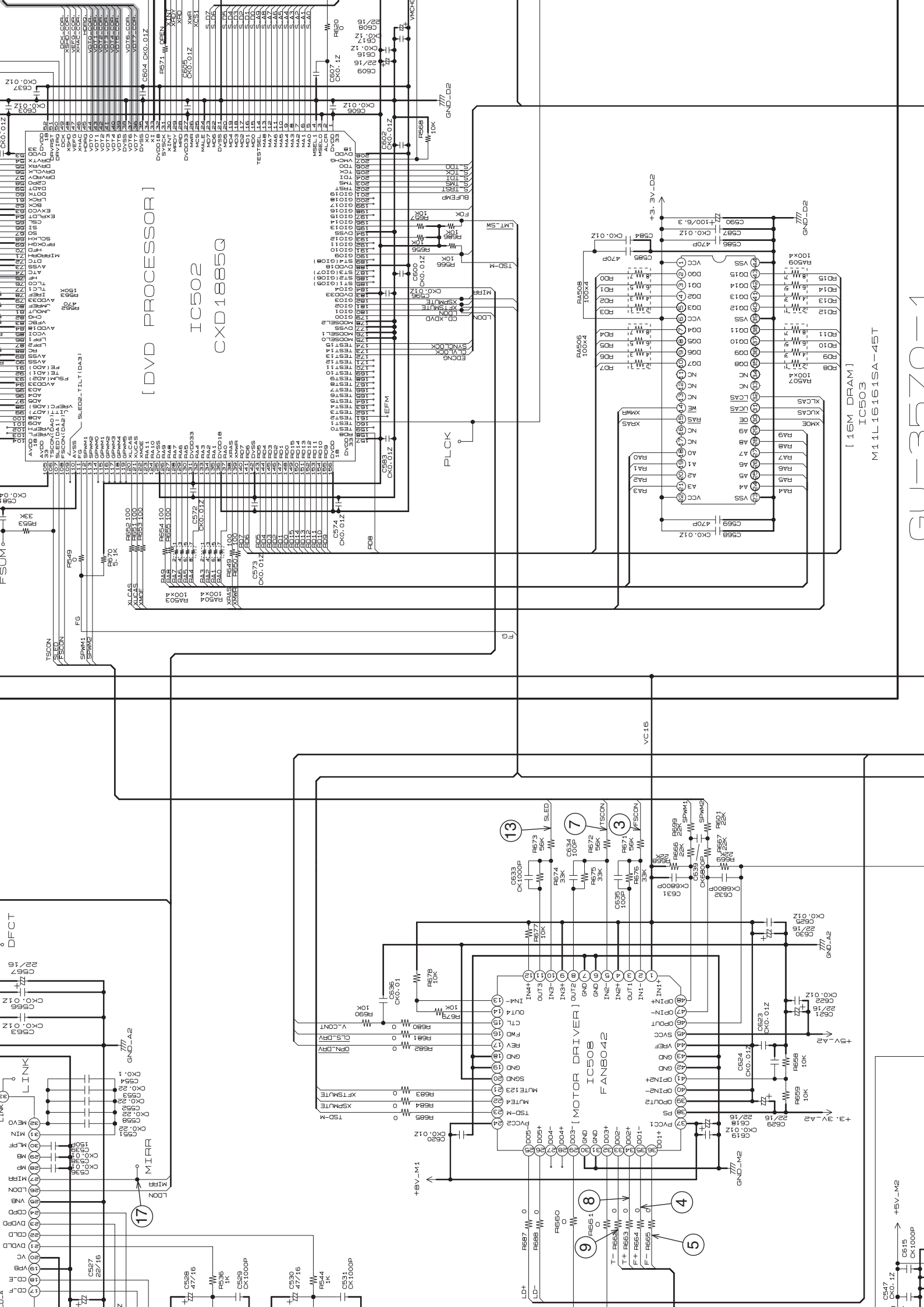

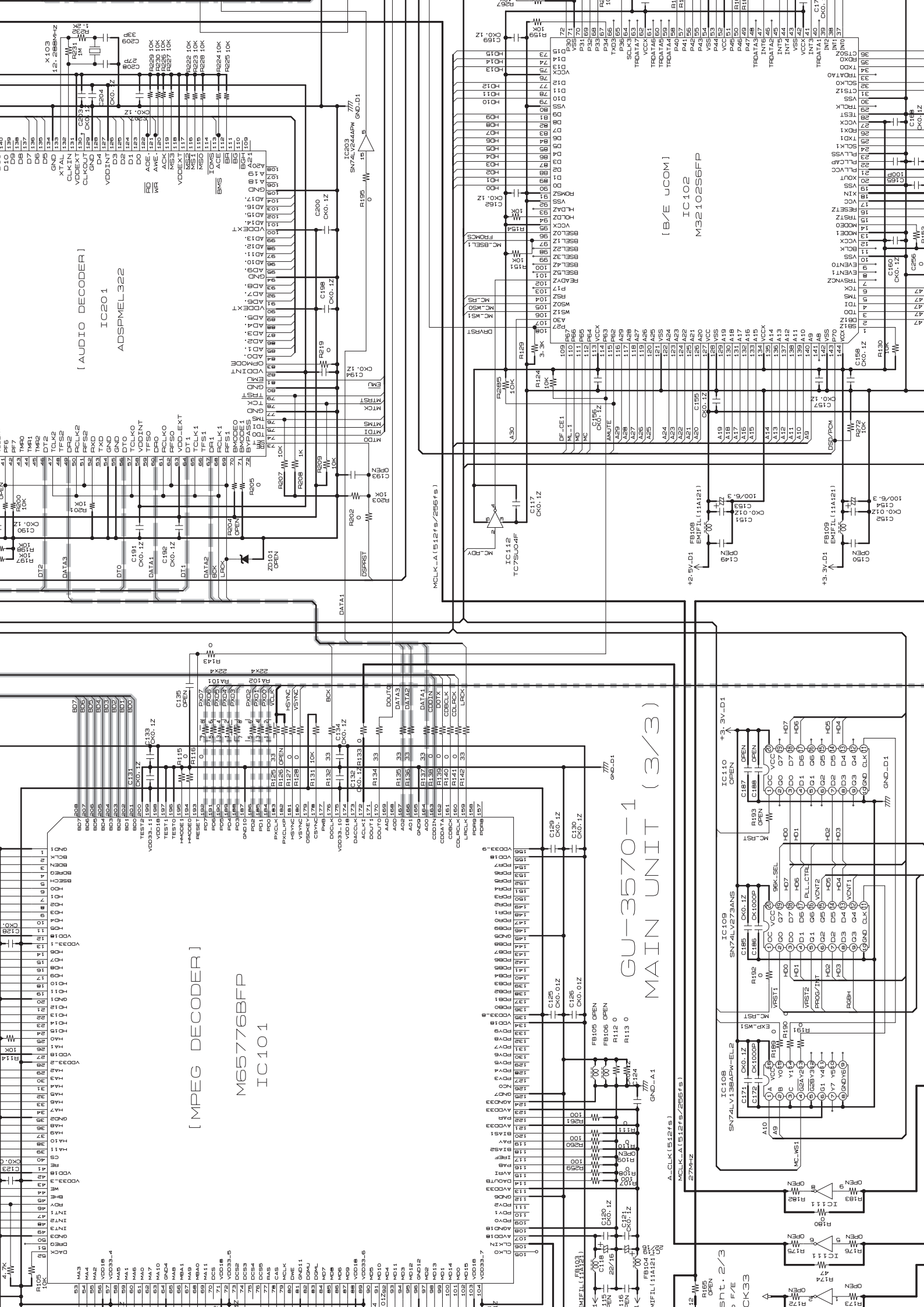

(AUDIO DECODER)
IC201
ADSPMEL322

(MPEG DECODER)
M65776BFP
IC101

GU-3570-1
MAIN UNIT (3/3)

(B/E UCOM)
IC102
M32102S6FP

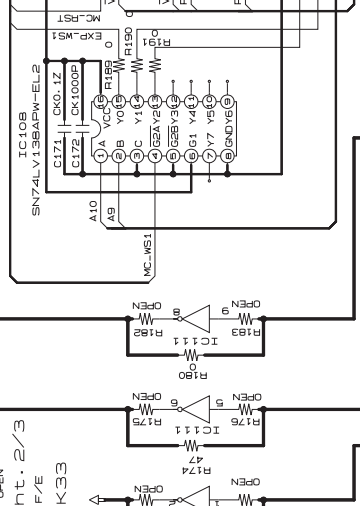
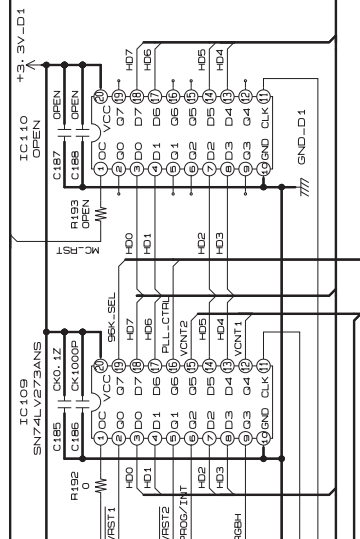
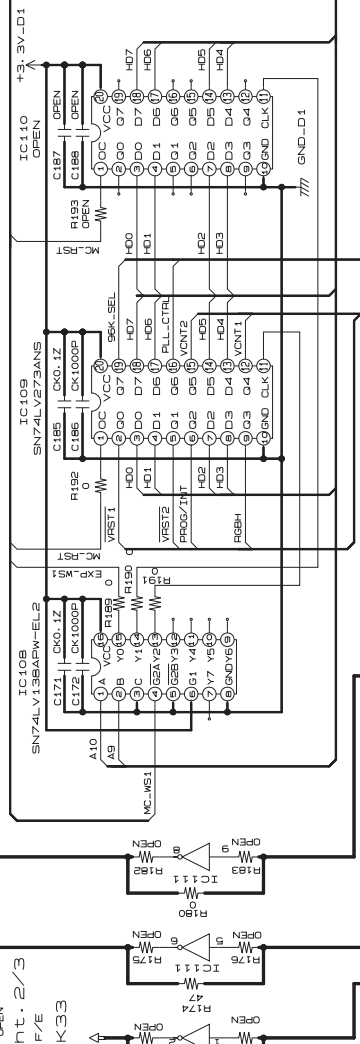

IC108
SN74LV138PW-EL2

IC109
SN74LV273ANS

IC110
SN74LV273ANS

IC111
11A121

IC112
11A121

IC113
11A121

IC102
M32102S6FP

IC201
ADSPMEL322

M65776BFP
IC101

GU-3570-1
MAIN UNIT (3/3)

IC108
SN74LV138PW-EL2

IC109
SN74LV273ANS

IC110
SN74LV273ANS

IC111
11A121

IC112
11A121

IC113
11A121

IC102
M32102S6FP

IC201
ADSPMEL322

M65776BFP
IC101

GU-3570-1
MAIN UNIT (3/3)

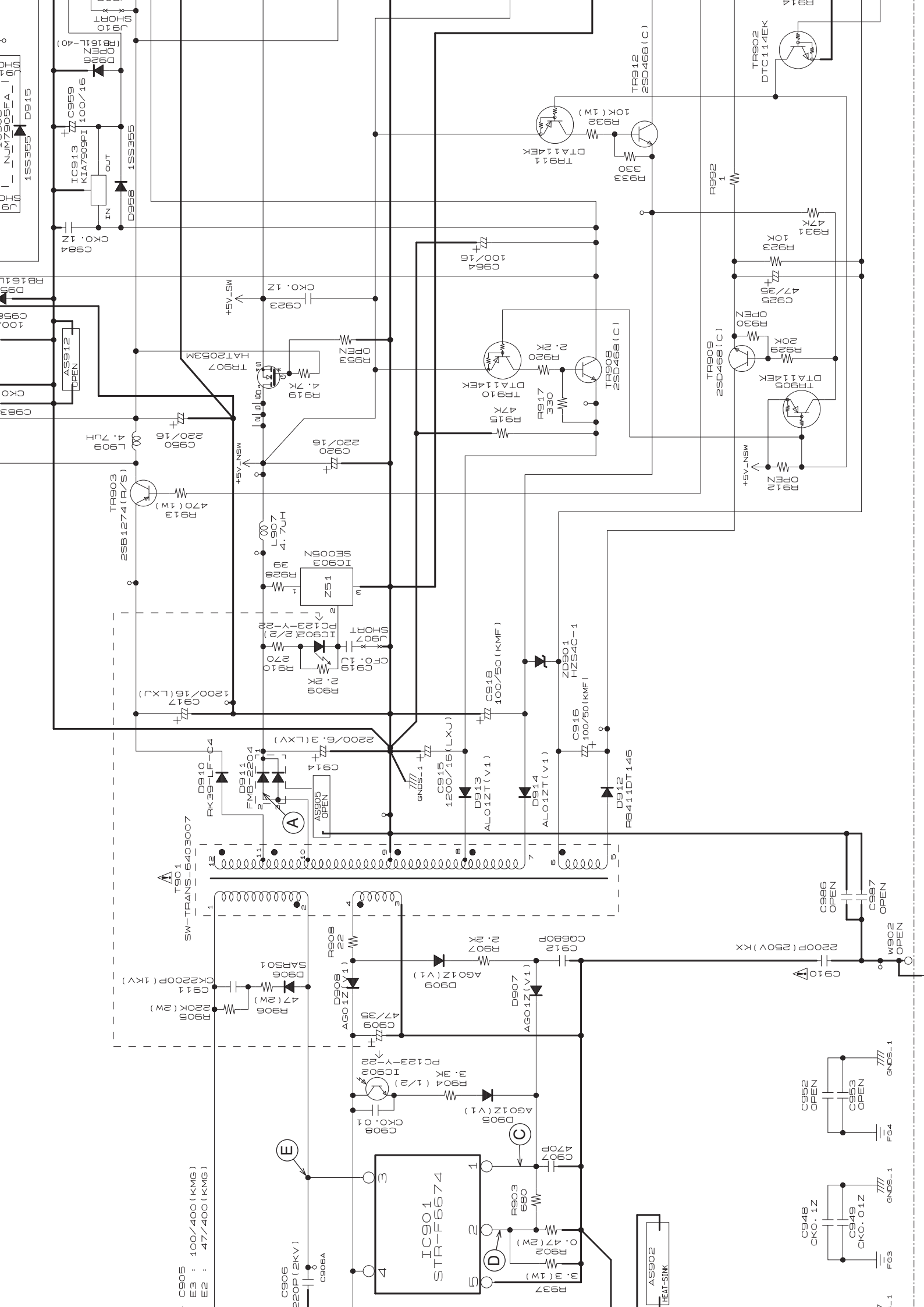

C905 : 220P(2KV)
 E3 : 100/400(KMG)
 E2 : 47/400(KMG)

C906
 220P(2KV)
 C906A

(E)

(C)

(D)

(A)

(B)

(F)

(G)

(H)

(I)

(J)

(K)

(L)

(M)

(N)

(O)

(P)

(Q)

(R)

(S)

(T)

(U)

(V)

(W)

(X)

(Y)

(Z)

(AA)

(AB)

(AC)

(AD)

(AE)

(AF)

(AG)

(AH)

(AI)

(AJ)

(AK)

(AL)

(AM)

(AN)

(AO)

(AP)

(AQ)

(AR)

(AS)

(AT)

(AU)

(AV)

(AW)

(AX)

(AY)

(AZ)

(BA)

(BB)

(BC)

(BD)

(BE)

(BF)

(BG)

(BH)

(BI)

(BJ)

(BK)

(BL)

(BM)

(BN)

(BO)

(BP)

(BQ)

(BR)

(BS)

(BT)

(BU)

(BV)

(BW)

(BX)

(BY)

(BZ)

(CA)

(CB)

(CC)

(CD)

(CE)

(CF)

(CG)

(CH)

(CI)

(CJ)

(CK)

(CL)

(CM)

(CN)

(CO)

(CP)

(CQ)

(CR)

(CS)

(CT)

(CU)

(CV)

(CW)

(CX)

(CY)

(CZ)

(DA)

(DB)

(DC)

(DD)

(DE)

(DF)

(DG)

(DH)

(DI)

(DJ)

(DK)

(DL)

(DM)

(DN)

(DO)

(DP)

(DQ)

(DR)

(DS)

(DT)

(DU)

(DV)

(DW)

(DX)

(DY)

(DZ)

(EA)

(EB)

(EC)

(ED)

(EE)

(EF)

(EG)

(EH)

(EI)

(EJ)

(EK)

(EL)

(EM)

(EN)

(EO)

(EP)

(EQ)

(ER)

(ES)

(ET)

(EU)

(EV)

(EW)

(EX)

(EY)

(EZ)

(FA)

(FB)

(FC)

(FD)

(FE)

(FF)

(FG)

(FH)

(FI)

(FJ)

(FK)

(FL)

(FM)

(FN)

(FO)

(FP)

(FQ)

(FR)

(FS)

(FT)

(FU)

(FV)

(FW)

(FX)

(FY)

(FZ)

(GA)

(GB)

(GC)

(GD)

(GE)

(GF)

(GG)

(GH)

(GI)

(GJ)

(GK)

(GL)

(GM)

(GN)

(GO)

(GP)

(GQ)

(GR)

(GS)

(GT)

(GU)

(GV)

(GW)

(GX)

(GY)

(GZ)

(HA)

(HB)

(HC)

(HD)

(HE)

(HF)

(HG)

(HH)

(HI)

(HJ)

(HK)

(HL)

(HM)

(HN)

(HO)

(HP)

(HQ)

(HR)

(HS)

(HT)

(HU)

(HV)

(HW)

(HX)

(HY)

(HZ)

(IA)

(IB)

(IC)

(ID)

(IE)

(IF)

(IG)

(IH)

(II)

(IJ)

(IK)

(IL)

(IM)

(IN)

(IO)

(IP)

(IQ)

(IR)

(IS)

(IT)

(IU)

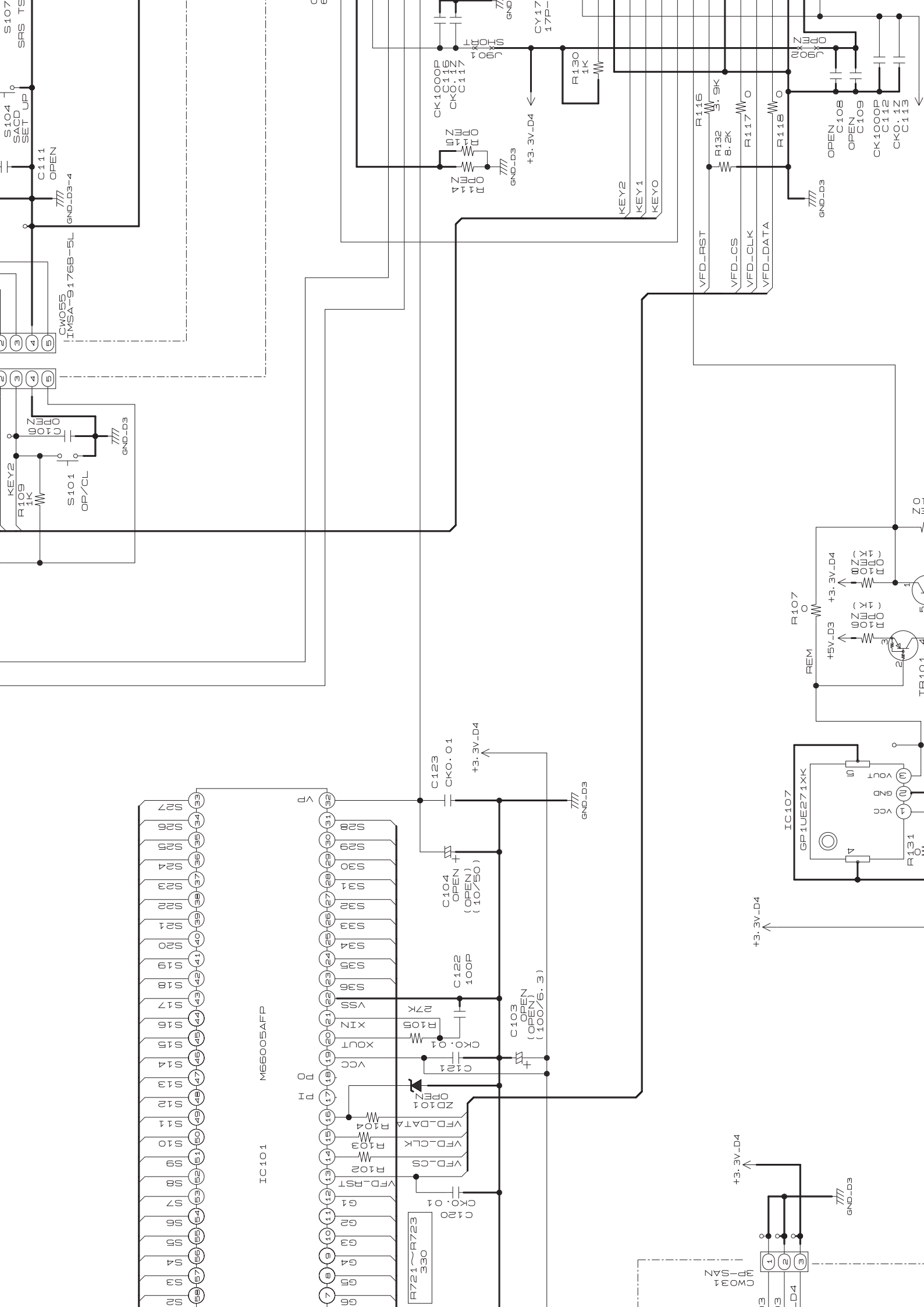

[E2][N] ONLY

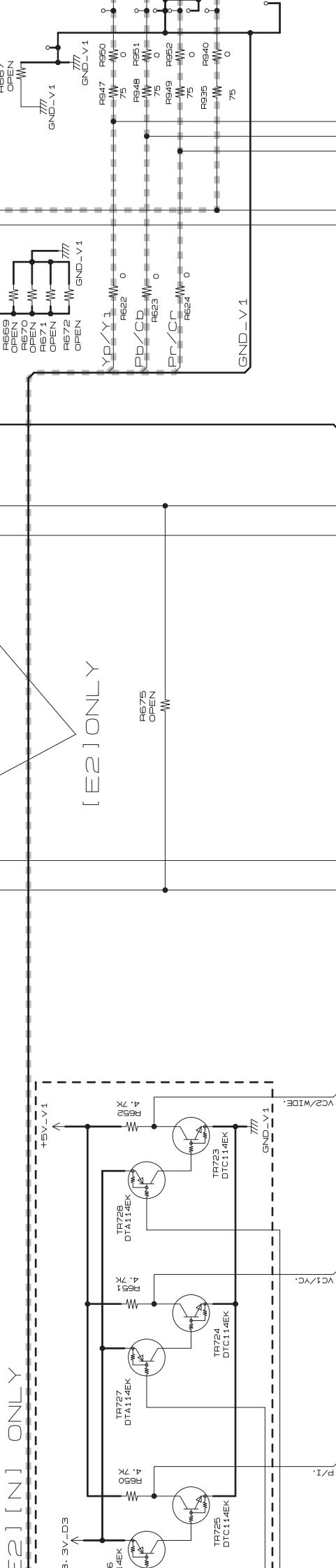

[E2] ONLY

[E2] ONLY

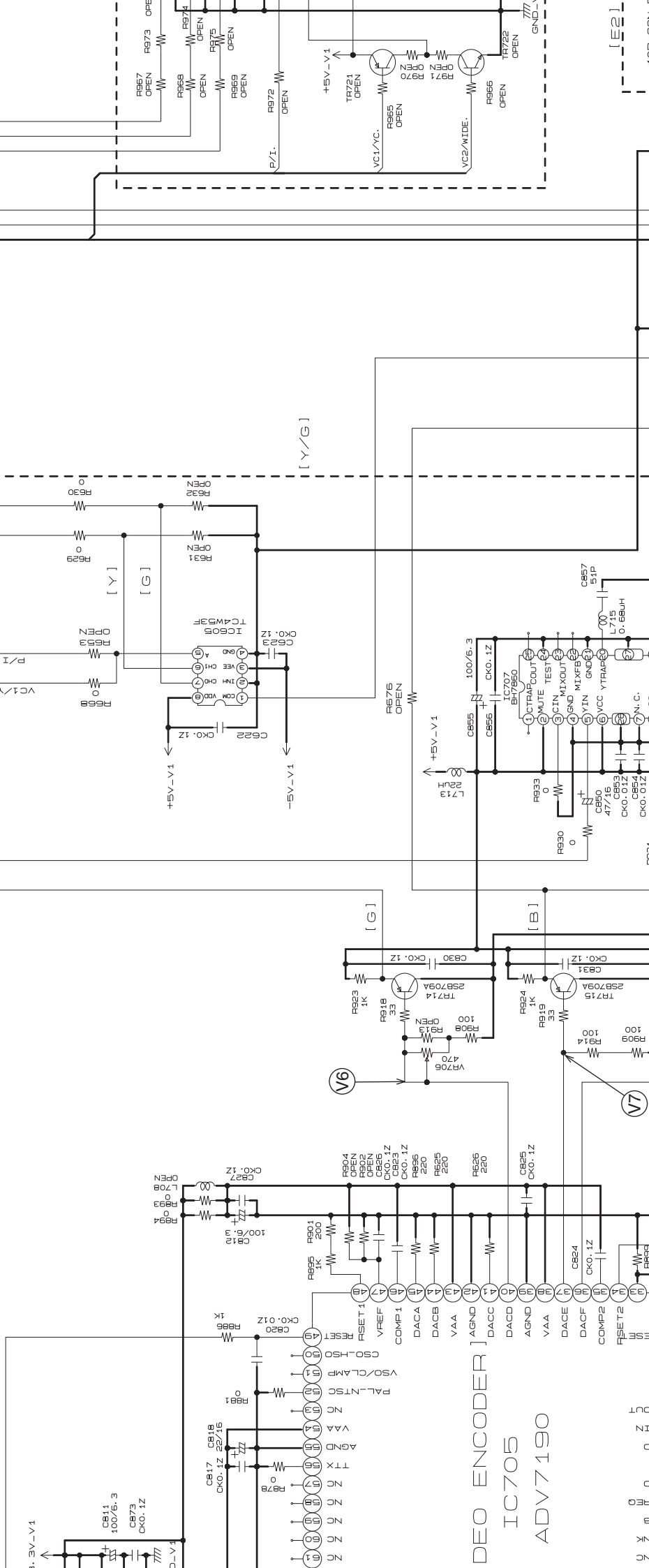

DEO ENCODER
IC705
ADV7190

V6

V7

[E2]

