

## SERVICE MANUAL

MODEL	JP	E3	E2	EK	EA	E1	E1K	E1C
HEOS Amp		✓	✓					

### Wireless Multi-Room Sound System

• For purposes of improvement, specifications and design are subject to change without notice.

• Please use this service manual with referring to the operating instructions without fail.

• Some illustrations using in this service manual are slightly different from the actual set.

# CONTENTS

<b>ABOUT THIS MANUAL</b> .....	3
What you can do with this manual .....	3
Using Adobe Reader (Windows version) .....	4
<b>SAFETY PRECAUTIONS</b> .....	6
<b>NOTE FOR SCHEMATIC DIAGRAM</b> .....	7
<b>NOTE FOR PARTS LIST</b> .....	7
<b>TECHNICAL SPECIFICATIONS</b> .....	9
<b>DIMENSION</b> .....	9
<b>DISASSEMBLY</b> .....	10
1. SIDE COVER AND SIDE KEY PCB.....	12
2. TOP COVER / BOTTOM COVER .....	13
3. CORE MODULE PCB ASSY .....	14
4. DIGITAL PCB .....	15
5. SUB SMPS PCB .....	16
6. MAIN (VOLUME-SMPS) PCB .....	17
7. FRONT PANEL ASSY .....	17
<b>Procedure after Replacing the Microprocessor, etc.</b> .....	18
<b>Firmware Update Procedure</b> .....	18
1. MAIN PCB Update Procedure.....	18
2. Updating by USB.....	20
3. Service region settings update procedures.....	21
4. How to check the version .....	22
<b>TROUBLE SHOOTING</b> .....	23
1. POWER.....	23
2. AUDIO.....	25
AUDIO CHECK PATH .....	27
MEASURING METHOD AND WAVEFORMS .....	31
<b>BLOCK DIAGRAM</b> .....	34
<b>POWER DIAGRAM</b> .....	35
<b>WIRING DIAGRAM</b> .....	36
<b>PRINTED Circuit BOARDS</b> .....	37
<b>SCHEMATIC DIAGRAMS</b> .....	40
MAIN .....	40
DSP DIR USB .....	41
DAMP .....	42
SMPS .....	43
FRONT .....	44
MAIN BT NFC KEY .....	45
TOUCH PAD .....	46
<b>EXPLODED VIEW</b> .....	48
<b>PACKING VIEW</b> .....	50
<b>SEMICONDUCTORS</b> .....	51
1. IC's.....	51

# ABOUT THIS MANUAL

Read the following information before using the service manual.

## What you can do with this manual

### Search for a Ref. No. (phrase) (Ctrl+Shift+F)

You can use the search function in Acrobat Reader to search for a Ref. No. in schematic diagrams, printed wiring board diagrams, block diagrams, and parts lists.

1. Press **Ctrl+Shift+F** on the keyboard.

- The Search window appears.

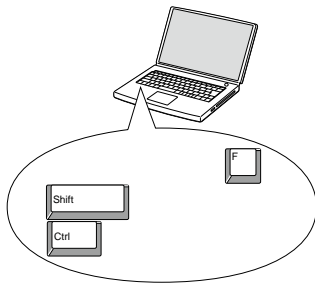

2. Enter the Ref. No. you want to search for in the Search window, and then click the **Search** button.

- A list of search results appears.

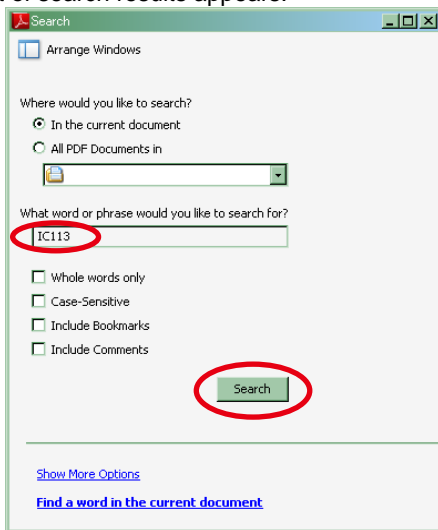

3. Click an item on the list.

- The screen jumps to the page for that item, and the search phrase is displayed.

### Jump to the target of a schematic diagram connector

Click the Ref. No. of the target connector in the red box around a schematic diagram connector.

- The screen jumps to the target connector.

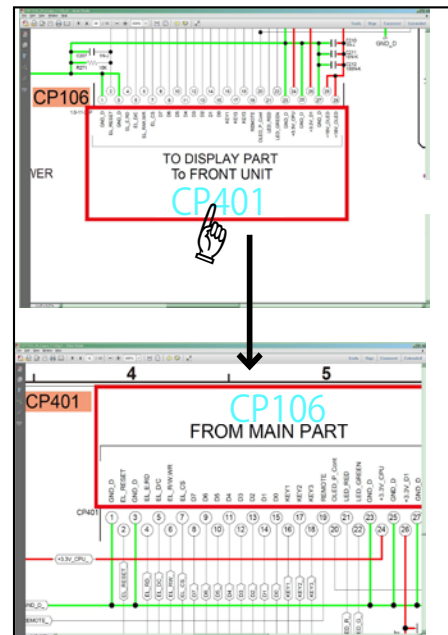

- Page magnification stays the same as before the jump.

## Using Adobe Reader (Windows version)

### Add notes to this data (Sign)

The Sign function lets you add notes to the data in this manual.

Save the file once you have finished adding notes.

#### [Example using Adobe Reader X]

On the "View" menu, click "Sign".

- The Sign pane appears.

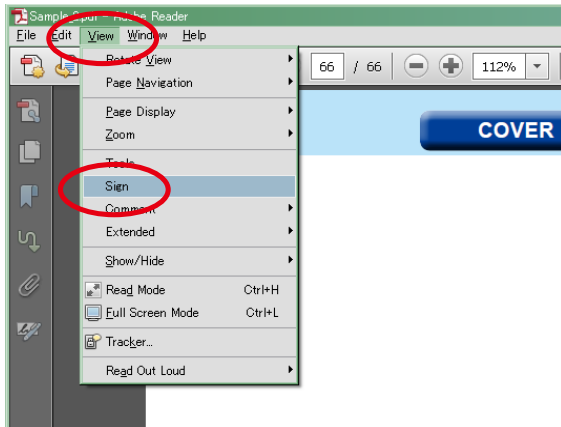

#### [Example using Adobe Reader 9]

On the "Document" menu, click "Sign".

### Magnify schematic / printed wiring board diagrams - 1

#### (Ctrl+Space, mouse operation)

Press **Ctrl+Space** on the keyboard and drag the mouse to select the area you want to view.

- The selected area is magnified.

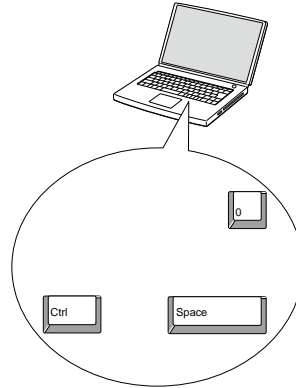

- When you want to move the area shown, hold down **Space** and drag the mouse.
- When you want to show a full page view, press **Ctrl+0** on the keyboard.

### Print a magnified part of the manual

The Properties dialog box and functions will vary depending on your printer.

1. Drag the mouse to magnify the part you want to print.
2. On the "File" menu, click "Print".
3. Configure the following settings in the Print dialog box.

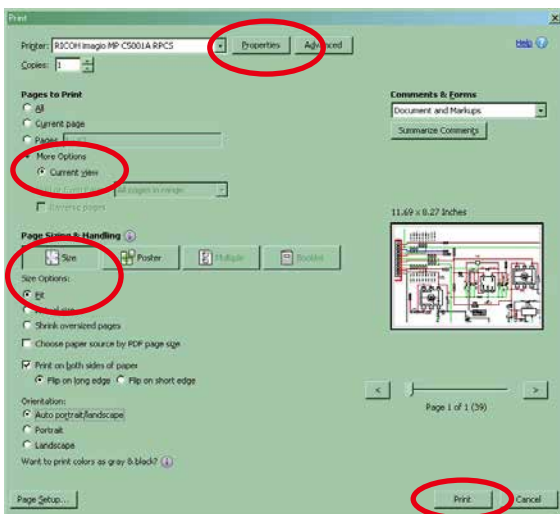

4. Click the **Print** button to start printing.

#### • Properties

Click this button and check that the printer is set to a suitable paper size.

#### • Page to print

Select the following checkbox.

"More Options" : "Current View"

#### • Page Sizing & Handling

Select the following checkbox.

"Size" / "Size Options" : "Fit"

## Magnify schematic / printed wiring board diagrams - 2

### (Pan & Zoom function)

The Pan & Zoom function lets you see which part of a magnified diagram is being shown in a separate window.

#### [Example using Adobe Reader X]

On the "View" menu, point to "Zoom", and then click "Pan & Zoom".

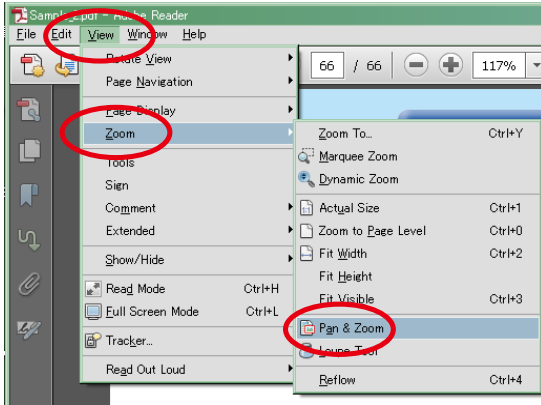

- The Pan & Zoom window appears on the screen.

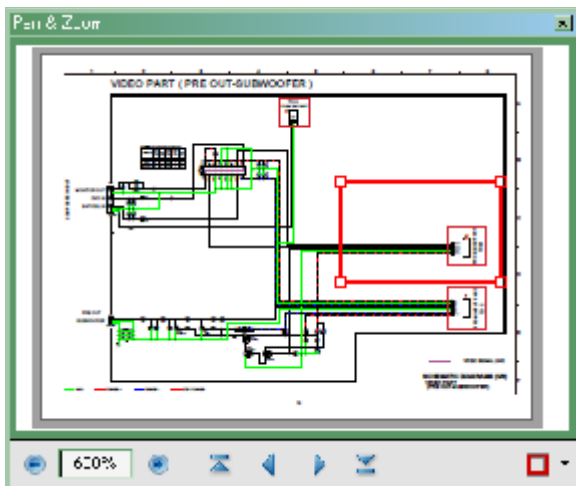

#### [Example using Adobe Reader 9]

On the "Tools" menu, point to "Select & Zoom", and then click "Pan & Zoom Window".

## Magnify schematic / printed wiring board diagrams - 3

### (Loupe Tool function)

The Loupe Tool function lets you magnify a specific part of a diagram in a separate window.

#### [Example using Adobe Reader X]

On the "View" menu, point to "Zoom", and then click "Loupe Tool".

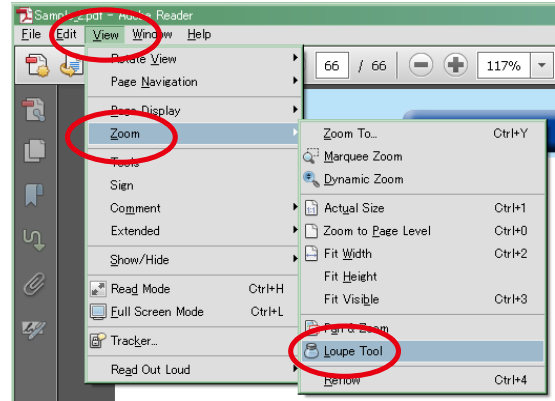

- The Loupe Tool window appears on the screen.

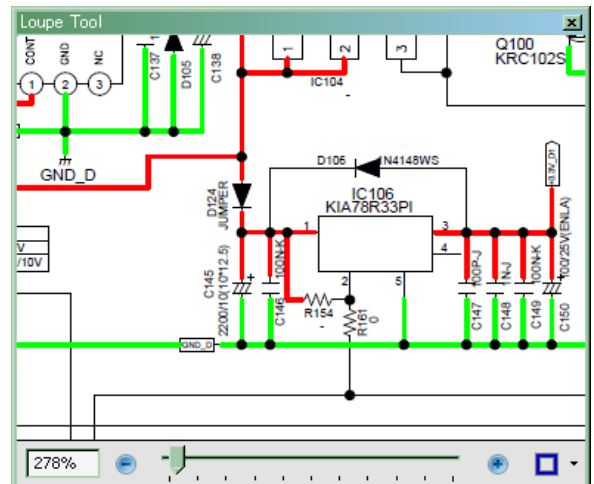

#### [Example using Adobe Reader 9]

On the "Tools" menu, point to "Select & Zoom", and then click "Loupe Tool Window".

## SAFETY PRECAUTIONS

The following items should be checked for continued protection of the customer and the service technician.

### leakage current check

Before returning the set to the customer, be sure to carry out either (1) a leakage current check or (2) a line to chassis resistance check. If the leakage current exceeds 0.5 milliamps, or if the resistance from chassis to either side of the power cord is less than 460 kohms, the set is defective.

Be sure to test for leakage current with the AC plug in both polarities, in addition, when the set's power is in each state (on, off and standby mode), if applicable.

## CAUTION Please heed the following cautions and instructions during servicing and inspection.

### ⊙ Heed the cautions!

Cautions which are delicate in particular for servicing are labeled on the cabinets, the parts and the chassis, etc. Be sure to heed these cautions and the cautions described in the handling instructions.

### ⊙ Cautions concerning electric shock!

- (1) An AC voltage is impressed on this set, so if you touch internal metal parts when the set is energized, you may get an electric shock. Avoid getting an electric shock, by using an isolating transformer and wearing gloves when servicing while the set is energized, or by unplugging the power cord when replacing parts, for example.
- (2) There are high voltage parts inside. Handle with extra care when the set is energized.

### ⊙ Caution concerning disassembly and assembly!

Through great care is taken when parts were manufactured from sheet metal, there may be burrs on the edges of parts. The burrs could cause injury if fingers are moved across them in some rare cases. Wear gloves to protect your hands.

### ⊙ Use only designated parts!

The set's parts have specific safety properties (fire resistance, voltage resistance, etc.). Be sure to use parts which have the same properties for replacement. The burrs have the same properties. In particular, for the important safety parts that are indicated by the ⚠ mark on schematic diagrams and parts lists, be sure to use the designated parts.

### ⊙ Be sure to mount parts and arrange the wires as they were originally placed!

For safety reasons, some parts use tapes, tubes or other insulating materials, and some parts are mounted away from the surface of printed circuit boards. Care is also taken with the positions of the wires by arranging them and using clamps to keep them away from heating and high voltage parts, so be sure to set everything back as it was originally placed.

### ⊙ Make a safety check after servicing!

Check that all screws, parts and wires removed or disconnected when servicing have been put back in their original positions, check that no serviced parts have deteriorate the area around. Then make an insulation check on the external metal connectors and between the blades of the power plug, and otherwise check that safety is ensured.

(Insulation check procedure)

Unplug the power cord from the power outlet, disconnect the antenna, plugs, etc., and on the power. Using a 500V insulation resistance tester, check that the insulation resistance value between the inplug and the externally exposed metal parts (antenna terminal, headphones terminal, input terminal, etc.) is 1MΩ or greater. If it is less, the set must be inspected and repaired.

## CAUTION Concerning important safety parts

Many of the electric and the structural parts used in the set have special safety properties. In most cases these properties are difficult to distinguish by sight, and the use of replacement parts with higher ratings (rated power and withstand voltage) does not necessarily guarantee that safety performance will be preserved. Parts with safety properties are indicated as shown below on the wiring diagrams and the parts list in this service manual. Be sure to replace them with the parts which have the designated part number.

- (1) Schematic diagrams.....Indicated by the ⚠ mark.
- (2) Parts lists.....Indicated by the ⚠ mark.

The use of parts other than the designated parts could cause electric shocks, fires or other dangerous situations.

## NOTE FOR SCHEMATIC DIAGRAM

### WARNING:

Parts indicated by the  $\triangle$  mark have critical characteristics. Use ONLY replacement parts recommended by the manufacturer.

### CAUTION:

Before returning the set to the customer, be sure to carry out either (1) a leakage current check or (2) a line to chassis resistance check. If the leakage current exceeds 0.5 milliamps, or if the resistance from chassis to either side of the power cord is less than 460 kohms, the set is defective.

### WARNING:

DO NOT return the set to the customer unless the problem is identified and remedied.

### NOTICE:

ALL RESISTANCE VALUES IN OHM. k=1,000 OHM / M=1,000,000 OHM

ALL CAPACITANCE VALUES ARE EXPRESSED IN MICRO FARAD, UNLESS OTHERWISE INDICATED. P INDICATES MICRO-MICRO FARAD. EACH VOLTAGE AND CURRENT ARE MEASURED AT NO SIGNAL INPUT CONDITION. CIRCUIT AND PARTS ARE SUBJECT TO CHANGE WITHOUT PRIOR NOTICE.

## NOTE FOR PARTS LIST

1. Parts indicated by "nsp" on this table cannot be supplied.
2. When ordering a part, make a clear distinction between "1" and "l" (i) to avoid mis-supplying.
3. A part ordered without specifying its part number can not be supplied.
4. Part indicated by "★" mark is not illustrated in the exploded view.

**WARNING:** Parts indicated by the  $\triangle$  mark have critical characteristics. Use ONLY replacement parts recommended by the manufacturer.

## INSTRUCTIONS FOR HANDLING SEMI-CONDUCTORS AND OPTICAL UNIT

Electrostatic breakdown of the semi-conductors or optical pickup may occur due to a potential difference caused by electrostatic charge during unpacking or repair work.

### 1. Ground for Human Body

Be sure to wear a grounding band (1 M $\Omega$ ) that is properly grounded to remove any static electricity that may be charged on the body.

### 2. Ground for Workbench

Be sure to place a conductive sheet or copper plate with proper grounding (1 M $\Omega$ ) on the workbench or other surface, where the semi-conductors are to be placed. Because the static electricity charge on clothing will not escape through the body grounding band, be careful to avoid contacting semi-conductors with your clothing

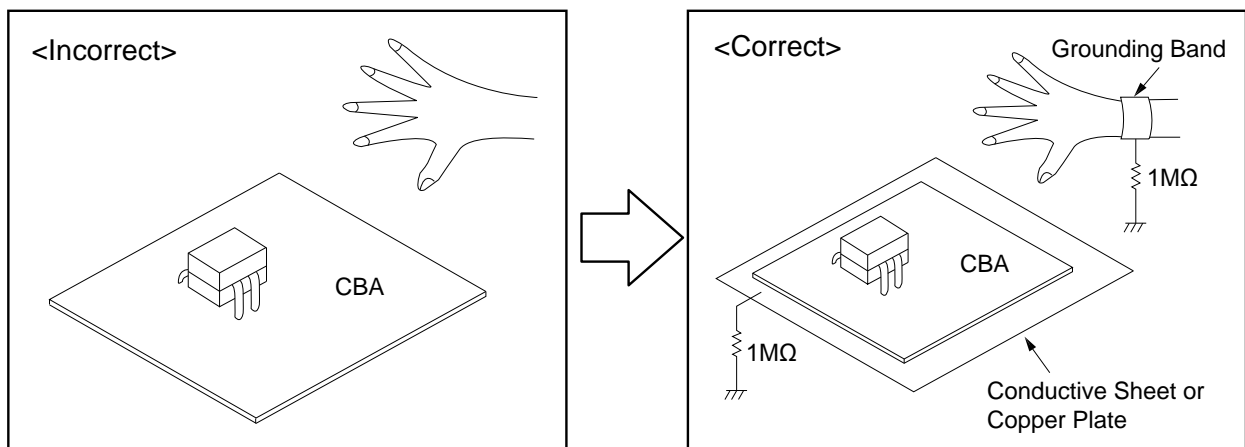





# TECHNICAL SPECIFICATIONS

## □ Audio section

<b>Power amplifier Rated output:</b>	2-channel driving 100W+100W (6Ω, 1 kHz, T.H.D. 0.7%)
<b>Output connectors:</b>	4 - 16 Ω/ohms
<b>Input sensitivity/Input impedance:</b>	150 mV/24 kΩ/kohms
<b>Total Distortion:</b>	ANALOG IN: 0.1 % (1 kHz)
<b>S/N ratio (10 W, 6 Ω/ohms, IHF-A):</b>	ANALOG IN: 83 dB (IHF-A weighted)
<b>Frequency response:</b>	20 Hz to 20 kHz : ±1 dB

## □ Wireless LAN section

<b>Network type:</b>	Conforming to IEEE 802.11a/b/g/n
<b>Used frequency range:</b>	2.41GHz - 2.472GHz, 5GHz

## □ General

<b>Operating temperature:</b>	41°F-95°F (5°C - 35°C)
<b>Power supply:</b>	AC 120V, 60Hz (for USA/Canada) AC 220-240V, 50/60Hz (for Europe)
<b>Power consumption:</b>	60W
<b>Power consumption in network standby mode:</b>	4W
<b>Power consumption in standby mode:</b>	0.3W

# DIMENSION

Unit : in. (mm)

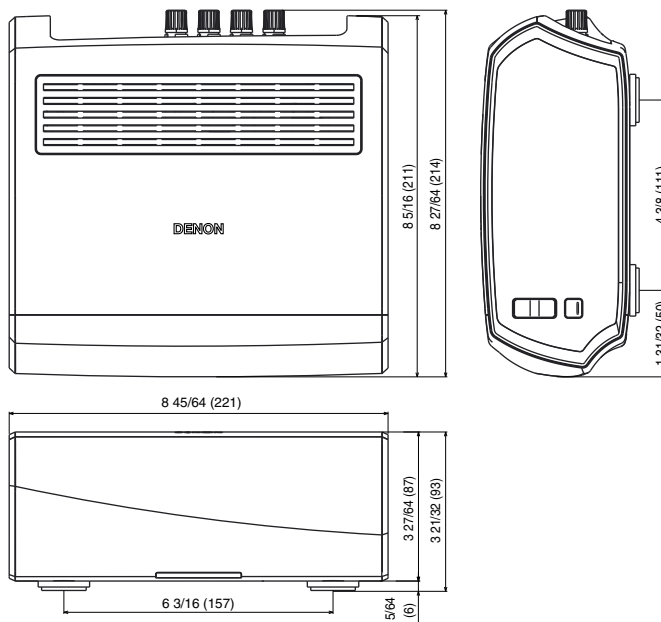

Weight : 6 lbs 2.8 oz (2.8 kg)

# DISASSEMBLY

- Remove each part in the order of the arrows below.
- Reassemble removed parts in the reverse order.
- Read "Precautions During Work" before reassembling removed parts.
- If wire bundles are removed or moved during adjustment or part replacement, reshape the wires after completing the work. Failure to shape the wires correctly may cause problems such as noise.

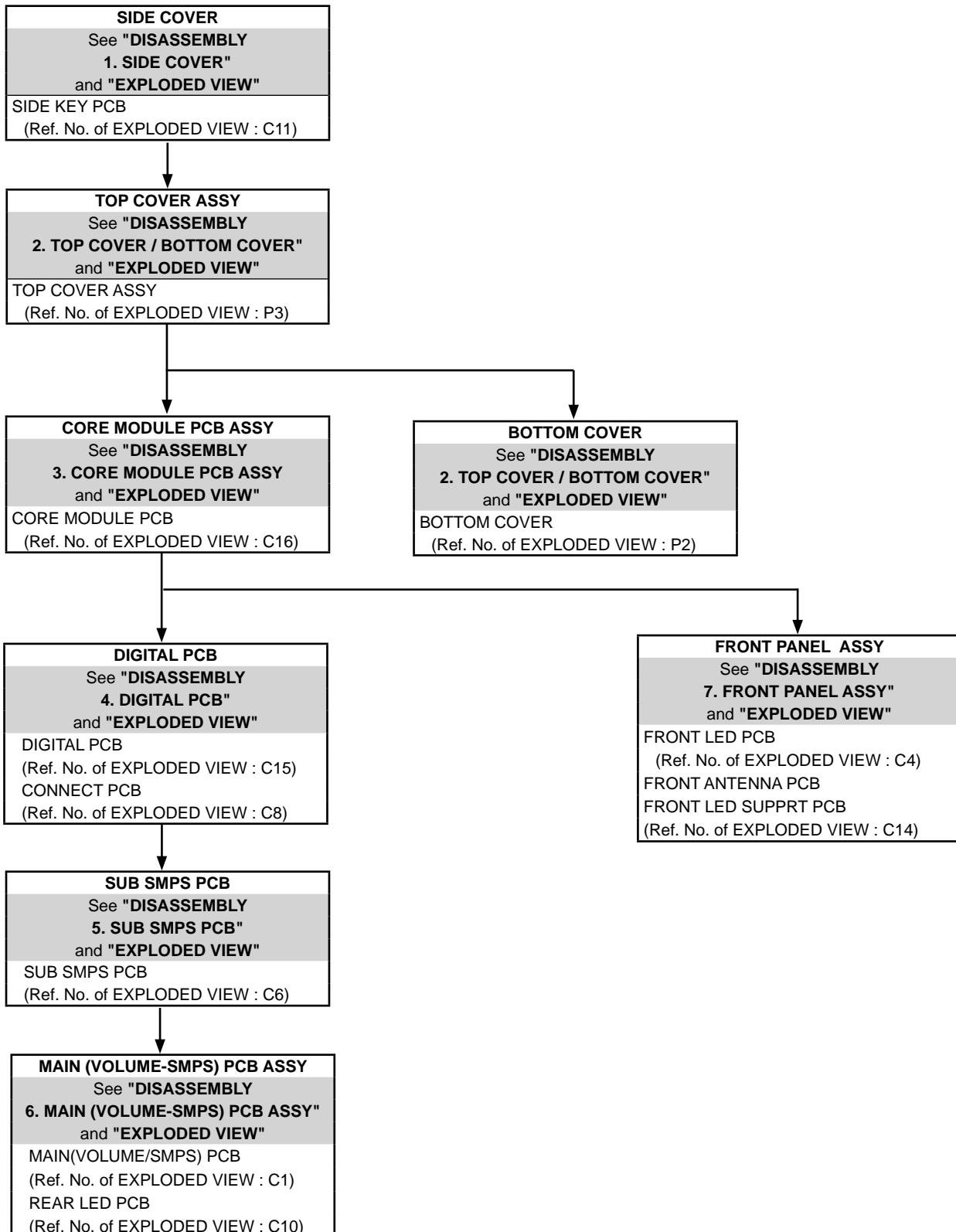

## Explanatory Photos for“ DISASSEMBLY”

- The angles from which the photos are taken are shown by “Photo angle: A, B, C, D” .
- See the diagram below about the shooting direction of each photograph.
- Photographs with no shooting direction indicated were taken from the top of the set.

### The viewpoint of each photograph (Shooting direction)



## 1. SIDE COVER AND SIDE KEY PCB

Proceeding : **SIDE COVER** → **SIDE KEY PCB**

(1) Remove the socket head cap screw.

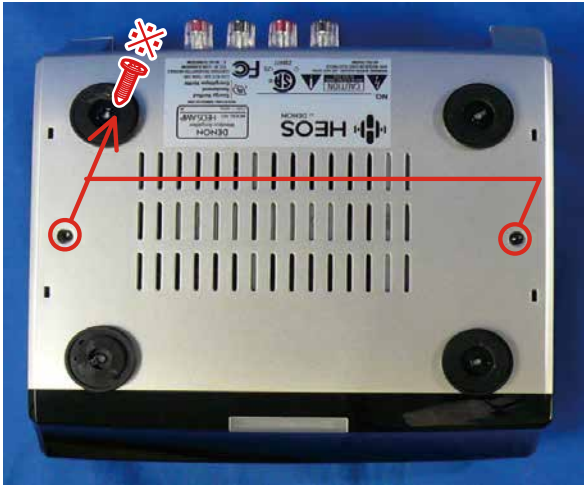

Shooting direction: C  
(Bottom side)

(2) Lift the SIDE COVER.

Put the driver in the groove and push the side panel. Use a  $\phi 2\text{mm}$  tool (bit or driver).



(3) The other side do the same.



(4) Disconnect the connector wire. Remove the SIDE KEY PCB.



## 2. TOP COVER / BOTTOM COVER

Proceeding : **SIDE COVER** → **TOP COVER / BOTTOM COVER**

(1) Remove the screws.

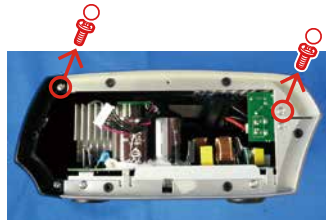

Shooting direction: E  
(Right side)

(2) Remove the screws and remove the top cover.

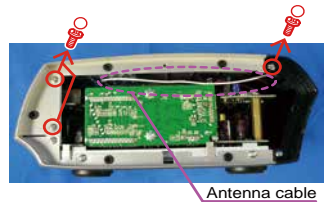

Shooting direction: F  
(Left side)

Note: When assembling, be careful to pinch the antenna cable.

(3) Remove the screws and remove the bottom cover.

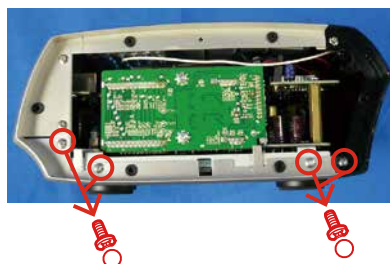
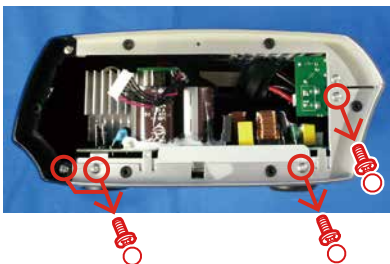

(4) Remove the screw.



### 3. CORE MODULE PCB ASSY

Proceeding : **SIDE COVER** → **TOP COVER** → **CORE MODULE PCB ASSY**

(1) Remove the screws. And pull up the PCB.

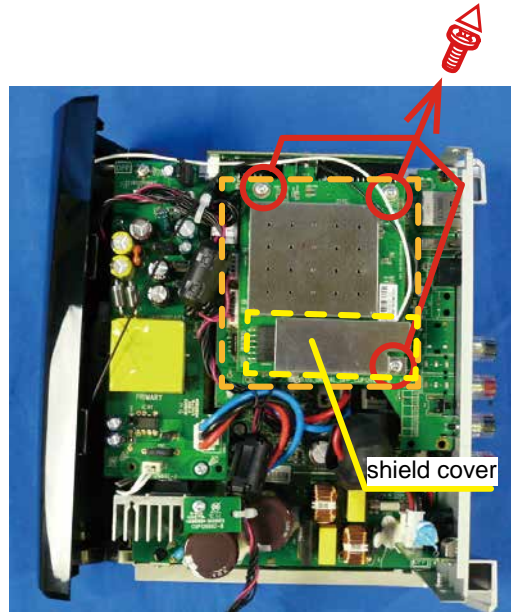

Shooting direction: D  
(Top side)

(2) Remove the shield cover and remove the antenna connector.

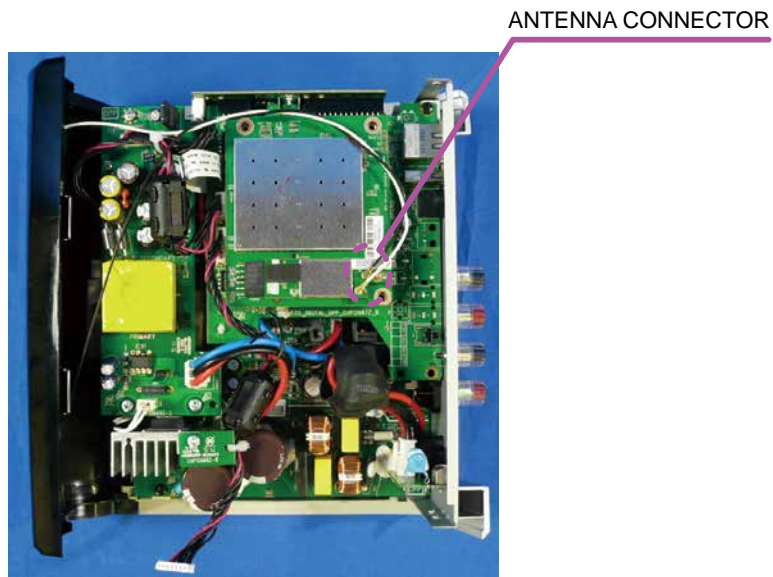

#### 4. DIGITAL PCB

Proceeding : **SIDE COVER** → **TOP COVER** → **MODULE PCB** → **DIGITAL PCB**

(1) Remove the screws.

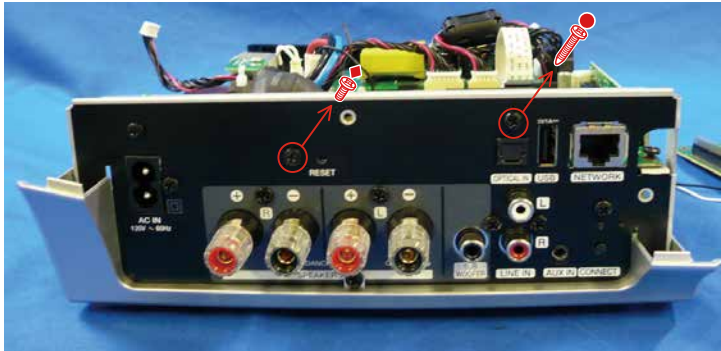

Shooting direction: B  
(Rear side)

(2) Remove the screws and remove the side connector PCB.

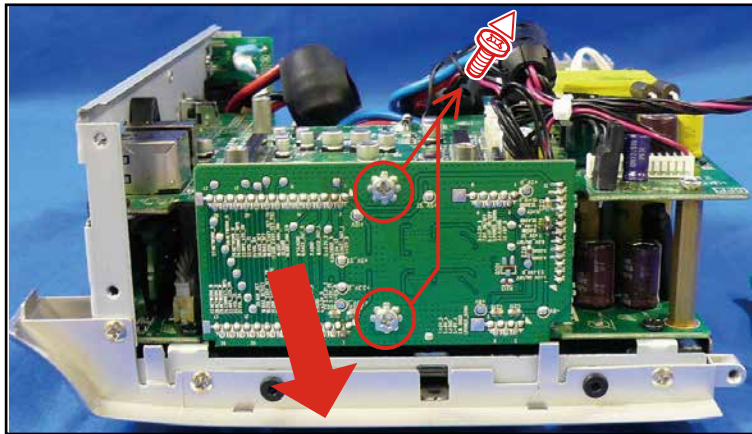

Shooting direction: F  
(Left side)

(3) Remove the screws, the connector wire and FFC. Loosen the style pin. Then remove the PCB from the support.

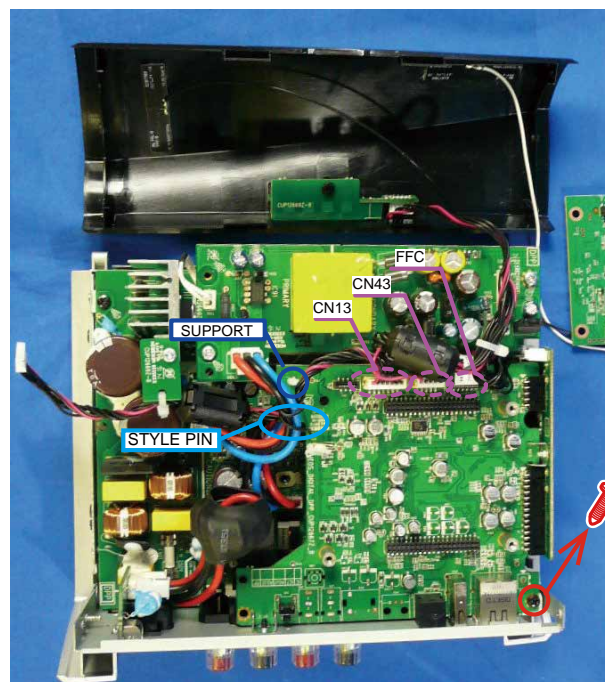

Shooting direction: D  
(Top side)

## 5. SUB SMPS PCB

Proceeding : **SIDE COVER** → **TOP COVER** → **CORE MODULE PCB ASSY** → **DIGITAL PCB**

→ **SUB SMPS PCB**

(1) Remove the screws. And connector wires.



Shooting direction: D  
(TOP side)



## 6. MAIN (VOLUME-SMPS) PCB

Proceeding : **SIDE COVER** → **TOP COVER** → **CORE MODULE PCB ASSY** → **DIGITAL PCB**  
→ **SUB SMPS PCB** → **MAIN PCB / REAR LED PCB / AC CONNECTOR PCB**

(1) Remove the screws.

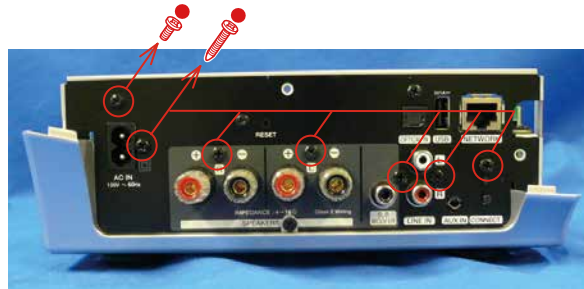

Shooting direction: B  
(Rear side)

(2) Remove the connector wire and FFC.

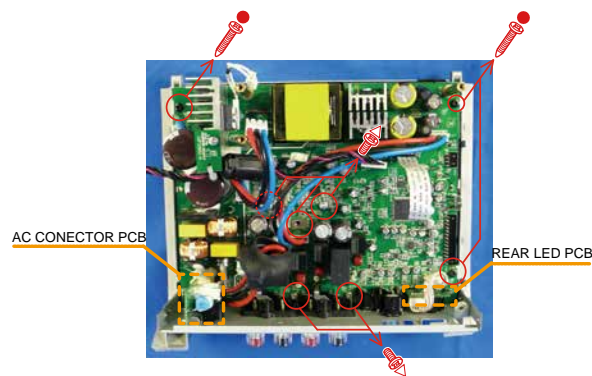

Shooting direction: D  
(Top side)

## 7. FRONT PANEL ASSY

Proceeding : **SIDE COVER** → **TOP COVER** → **BOTTOM COVER** → **FRONT PANEL ASSY**

(1) Remove the screw.

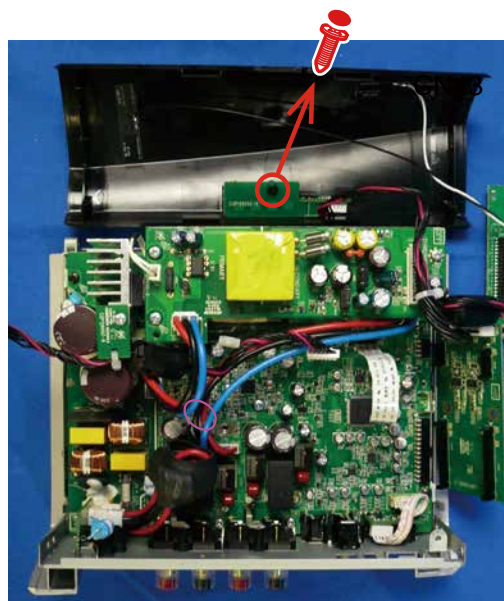

Shooting direction: D  
(Top side)

## PROCEDURE AFTER REPLACING THE MICROPROCESSOR, ETC.

The procedure after replacing the u-COM (microprocessor), flash ROM, etc. is as follows.

PCB Name	Ref. No.	Description	Procedure after Replacement	Remark
DIGITAL	-	DIGITAL PCB	D	<ul style="list-style-type: none"> <li>• Be sure to update the firmware.</li> <li>• Be sure to rewrite the service region setting.</li> </ul>

Procedure after Replacement

**A**: The software has been written. The software is not written at the time of replacement.

**B**: The software has been written. The software may need to be rewritten by version updates. Check the version.

**C**: The software has not been written. The software needs to be written after replacement.

See "**Firmware Update Procedure**" for information on writing the software.

**D**: The software has been written. Be sure to rewrite with the latest software for your service region.

See "**Firmware Update Procedure**" for information on writing the software.

## FIRMWARE UPDATE PROCEDURE

### 1. MAIN PCB Update Procedure

#### 1.1. Items to Be Prepared

- Mobile device
- A broadband internet connection
- Modem
- Router
- Ethernet cable (CAT-5 or greater recommended)

#### 1.2. Connection of HEOS

If you are connecting the HEOS Link to a wired network, connect the included Ethernet cable between the HEOS Link and your router. Do not connect the Ethernet cable if you are connecting your HEOS Link to a wireless network.

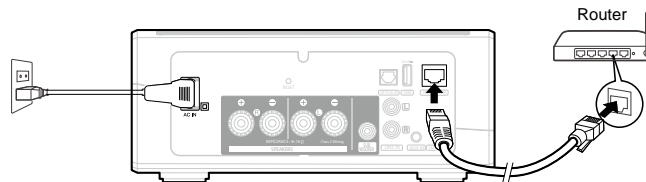

- (1) Download the Denon HEOS App Go to the App Store™ or to Google Play™ and search for “Denon HEOS” to download and install.



- (2) Launch the Denon HEOS App

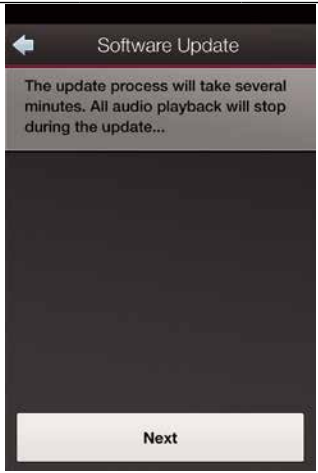
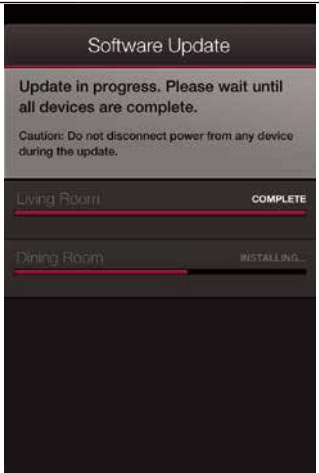
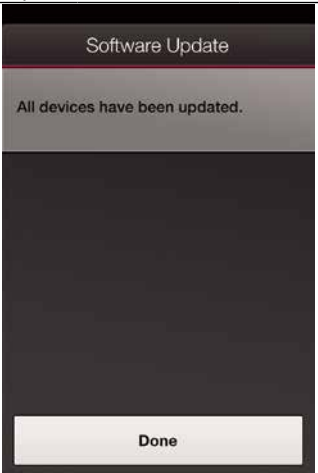

(3) If there is a software update, follow step 1 to step 4 below.

Step 1	→	Step 2	→	Step 3	→	Step 4
<p>Tap the "Update Now".</p> 		<p>Tap the "Next".</p> 		<p>The software is written to this Unit.</p> 		<p>"Update completed" is displayed. Tap the "Done"</p> 
				<p>Note: This display is updating two units at the same time.</p>		

(4) Be sure to rewrite the service region setting.  
See 21 page "Service region settings update procedures".

## 2. Updating by USB

The latest firmware can be downloaded to a USB memory for updates.

### 2.1. Connecting to the USB Memory

#### (1) Preparation

- USB format: Prepare a USB memory formatted in FAT32.
- Do not run the USB memory through a hub.
- Do not connect a computer to the USB port of this unit using a USB cable.
- Do not use an extension cable when connecting the USB unit.

### 2.2. Download and update the Firmware.

1. Download the HEOS Player's firmware from SDI.
  2. Save the firmware file to the PC.
  3. Copy the firmware to USB memory.
  4. Connect the USB memory to the HEOS Player's USB Port.
  5. Updating is started automatically.
6. Player's status LED should be blinking amber during upgrading the firmware.  
Exsample of HEOS Link LED Actions.

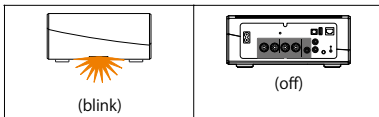

LED on the front is blinking amber.

7. One the upgrade is complete, the player reboots automatically.  
Exsample of HEOS Link LED Actions.

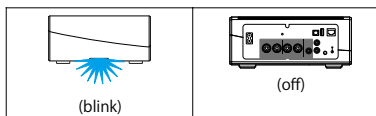

LED on the front is blinking blue.

8. Ready-Configured and connected to your network.  
Exsample of HEOS Link LED Actions.

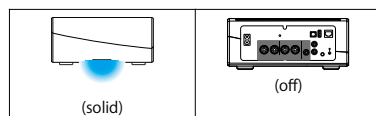

9. Be sure to rewrite the service region setting.  
See 21 page "Service region settings update procedures".

#### --- Precautions for Updates ---

- Never remove the USB memory before the update is finished.
- Never turn off the power before an update is completed.

Once an update is started, normal operations cannot be performed until it is completed.

### 3. Service region settings update procedures

Write the Service Region setting file to this unit from the USB memory.

#### 3.1. Items to Be Prepared

- Windows PC
- USB format : Prepare a USB memory formatted in FAT16 or FAT32.

Note :

- Do not run the USB memory through a hub.
- Do not connect a computer to the USB port of this unit using a USB cable.
- Do not use an extension cable when connecting the USB unit.

#### 3.2. Creating a service region setting file

(1) On the PC, click [Start button] – [Accessories] – [notepad] to start the notepad application.

(2) Enter 'TEXT'.

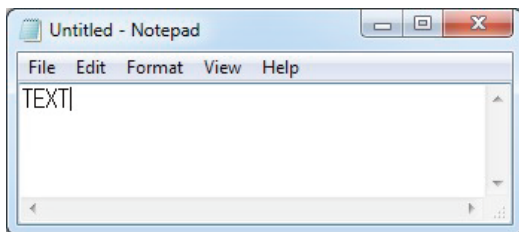

(3) Click the "File" and Click the "Save As..." button.

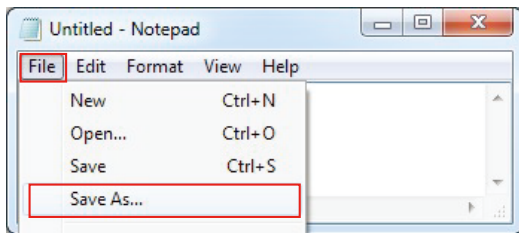

(4) Input File name and Click Save button.

Note : Typing the file name surrounded by double quotes.(No need file extension)

Model Area	File name
North America	"denon-config-locale-set-1"
Europe	"denon-config-locale-set-2"

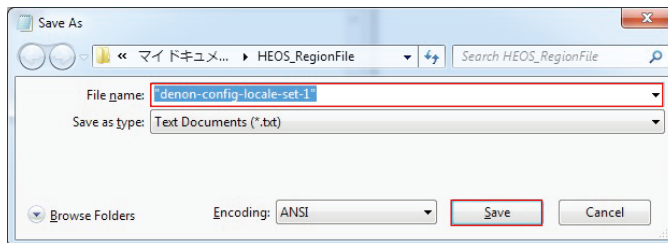

(5) Copy the created file to the USB memory.

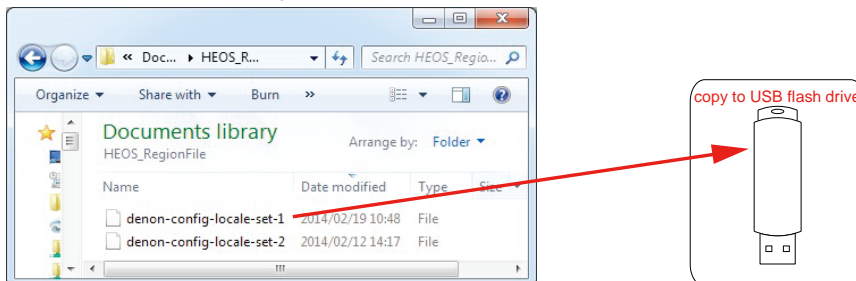

#### 3.3. Insert the USB memory in the USB port

- (1) Insert the USB flash memory that contains the file created in the steps above to the USB slot on the back panel of this unit.
- (2) Check that the LED on the front panel of this unit is flashing, and then remove the USB flash memory.
- (3) This unit automatically restarts and the changes to the service region settings are complete.

## 4. How to check the version

(1) How to check the version for "HEOS".(The figure is HEOS3 model)

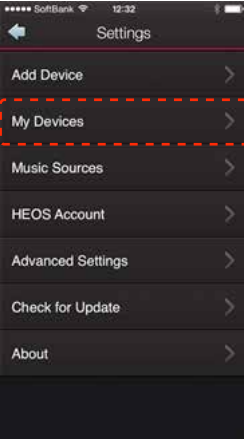
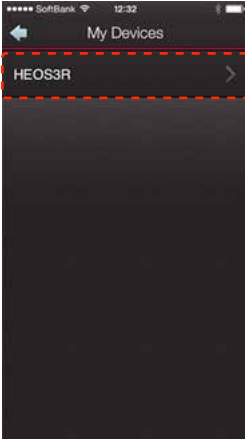
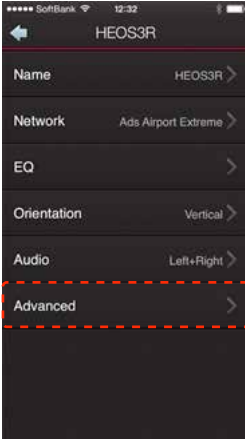

From "Settings" menu of the HEOS application, please display the "About" menu according to the following operation.

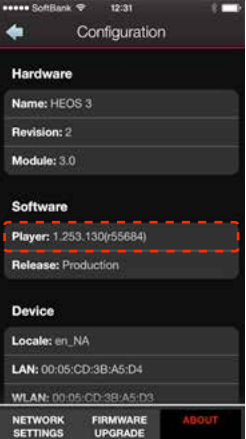
Step 1	Step 2	Step 3
Tap the "My Devices".	Tap the "HEOS3R".	Tap the "Advanced".
		

Step 4	Step 5
Tap the "About".	Check the version.
	

(2) How to check the version for "HEOS Apps".

From "Settings" menu of the HEOS application, please display the "About" menu according to the following operation.

Step 1	Step 2
Tap the "About".	Check the version.
	
	
<b>Display is different depending on the version of Apps.</b>	

# TROUBLE SHOOTING

## 1. POWER

### 1.1. The unit does not power on

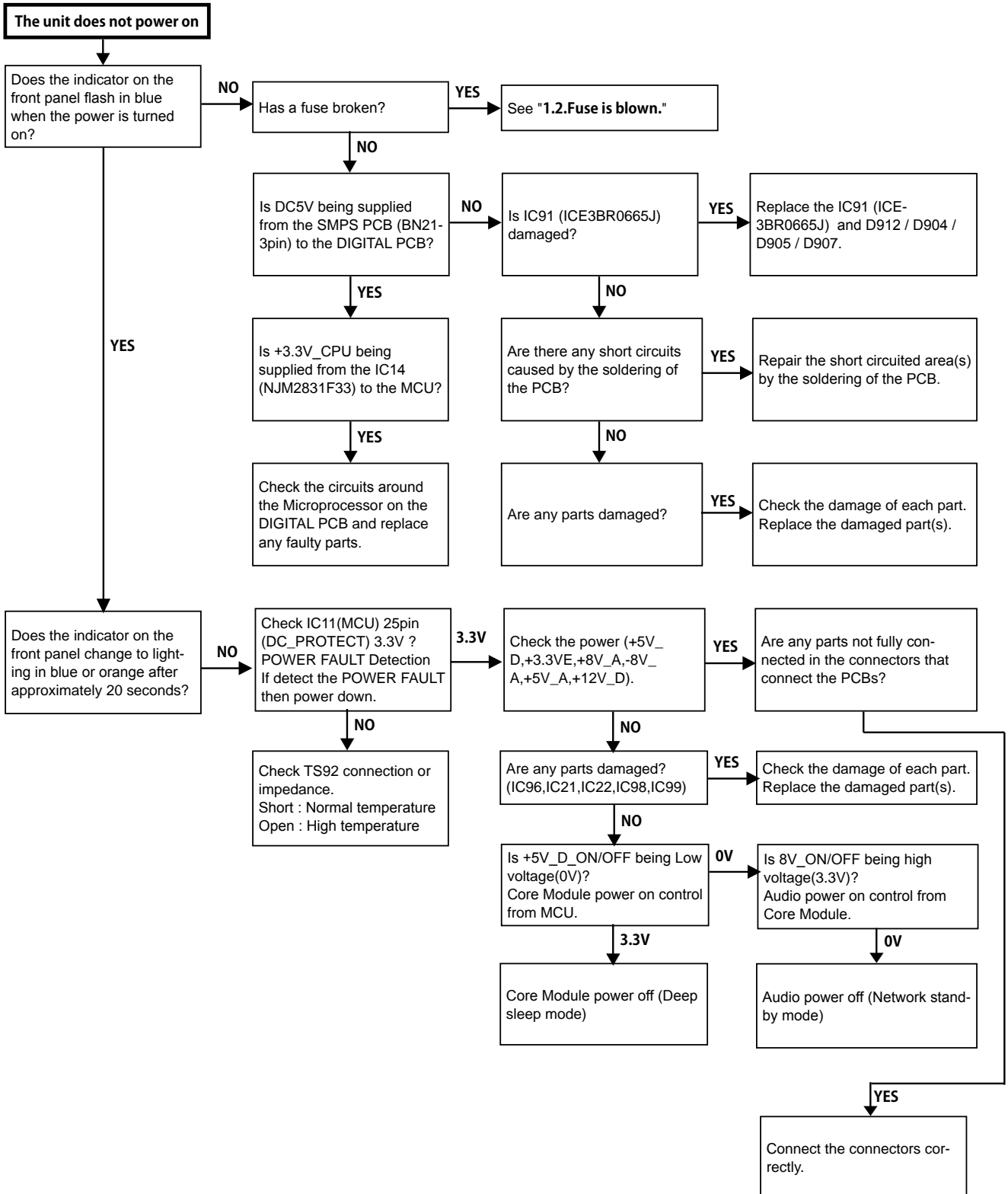

## 1.2. Fuse is blown

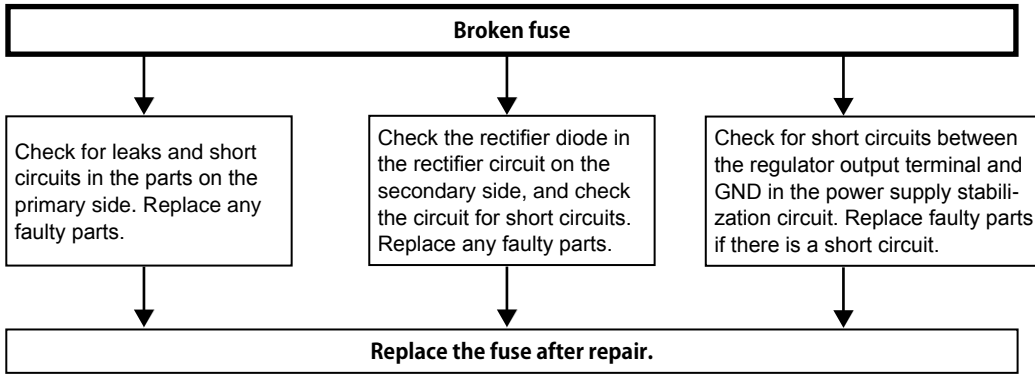



## 2. AUDIO

### 2.1. AUDIO CHECK

#### 2.1.1. Analog OUT

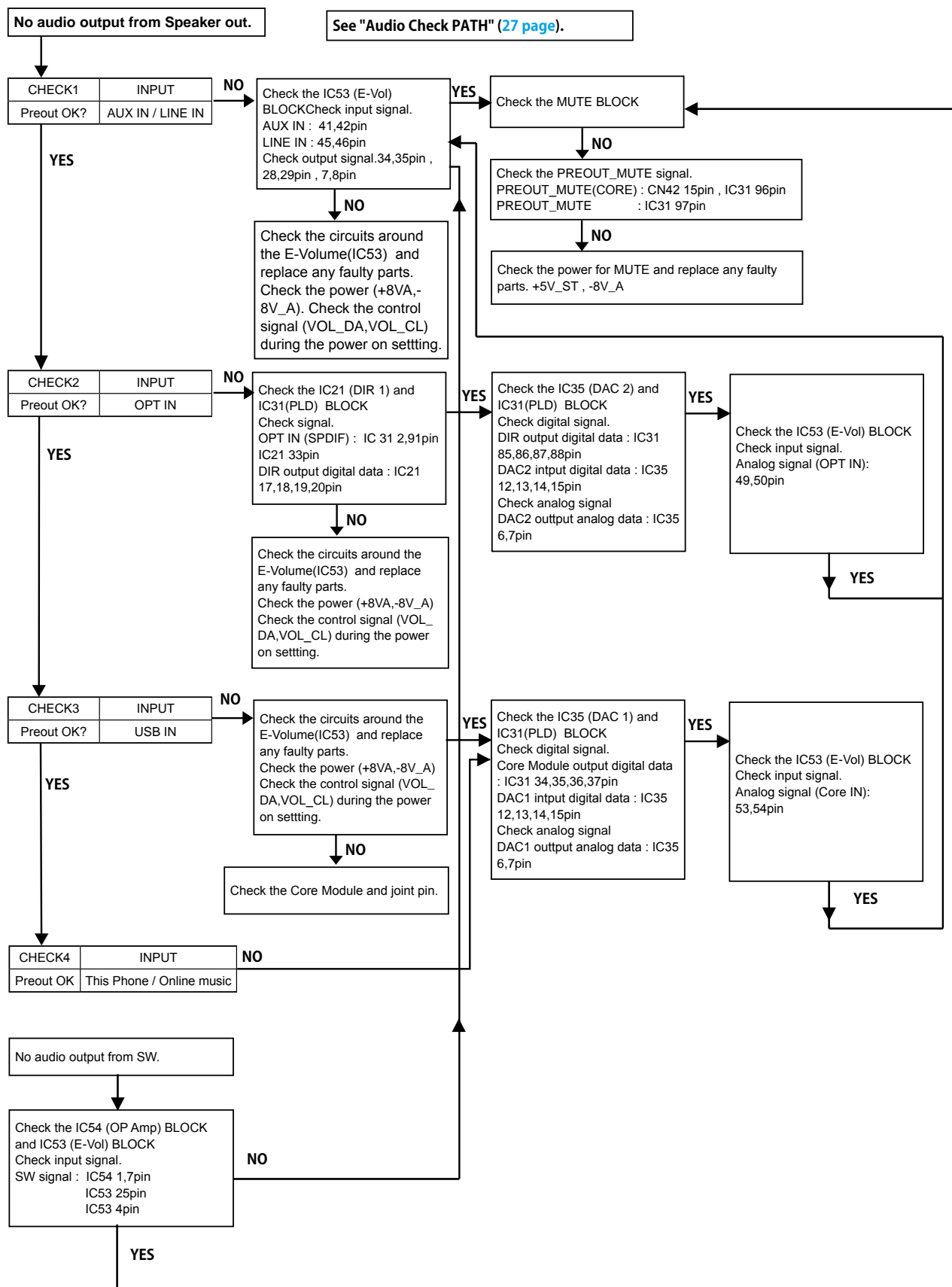

## 2.1.2. Another HEOS play

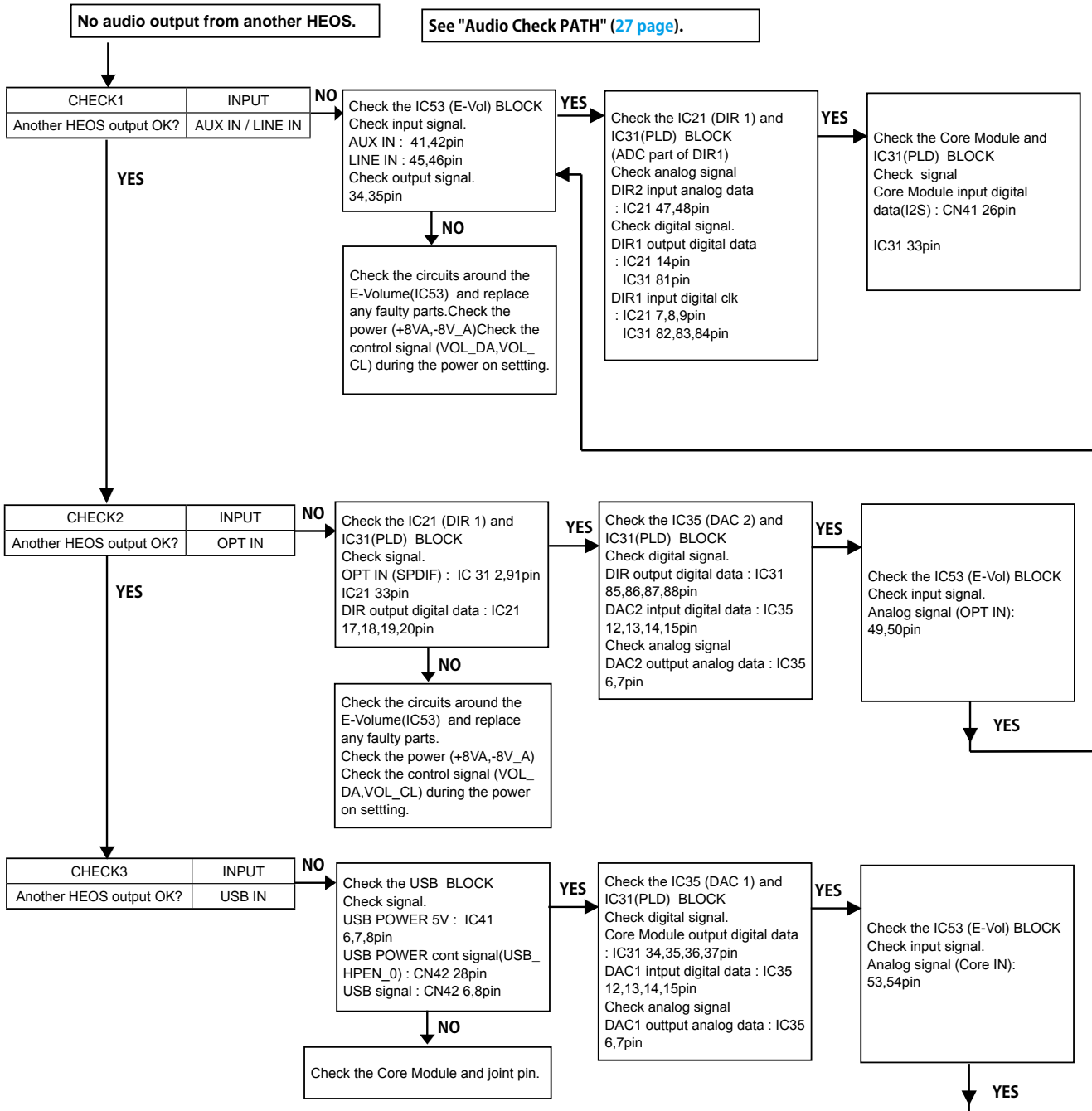

**AUDIO CHECK PATH  
AUX IN / LINE IN**

**BLOCK DIAGRAM**

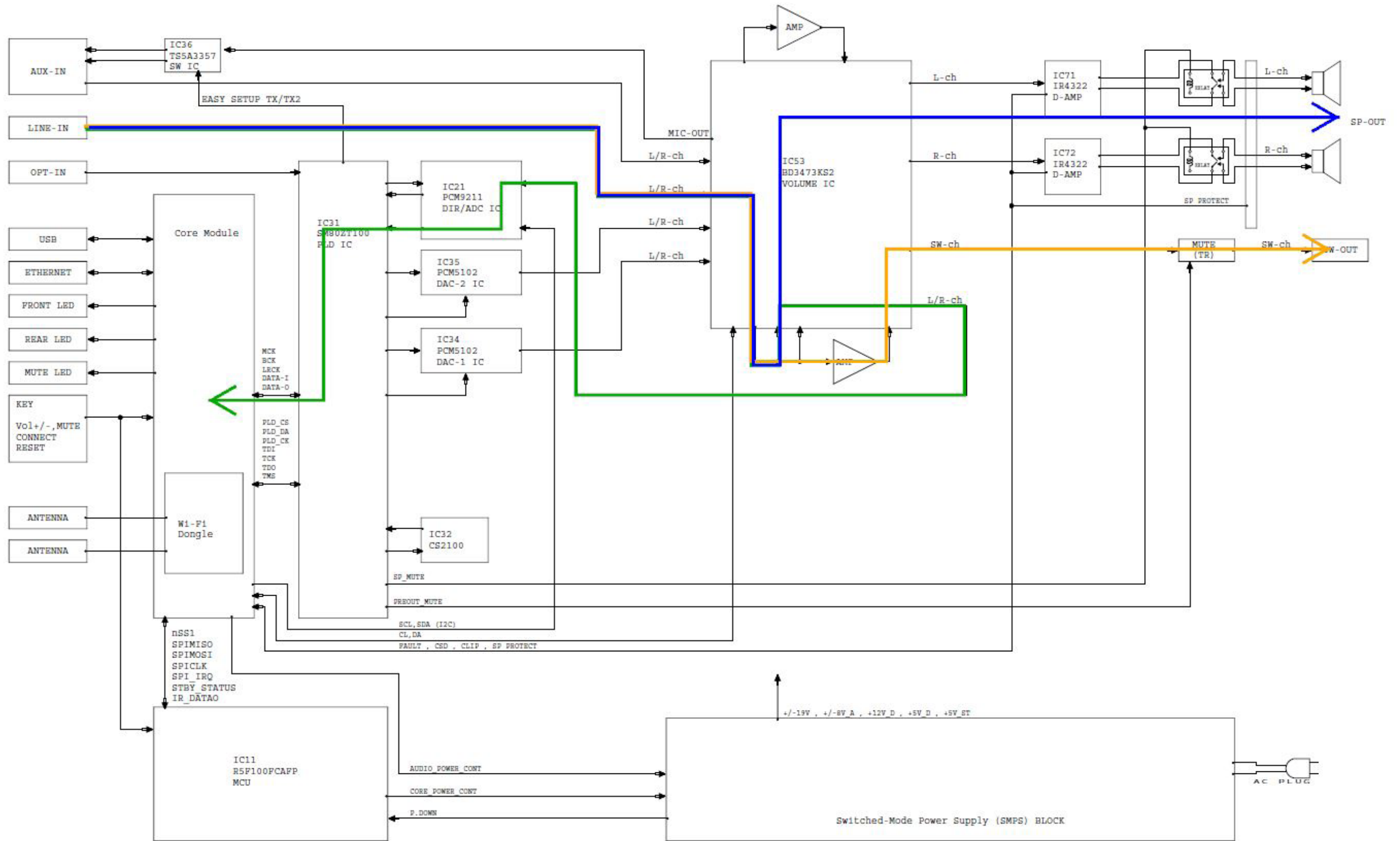

# BLOCK DIAGRAM

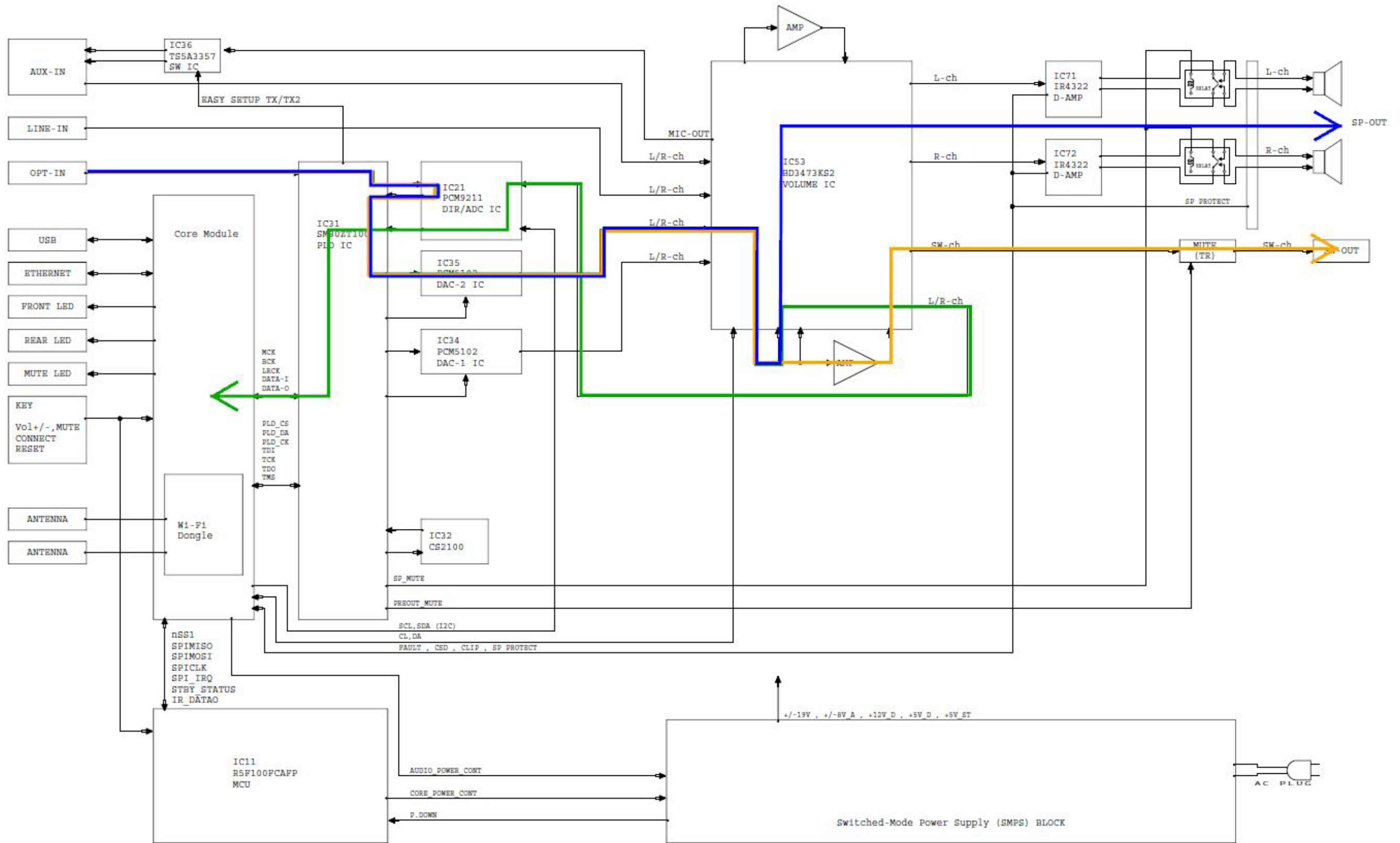

# BLOCK DIAGRAM

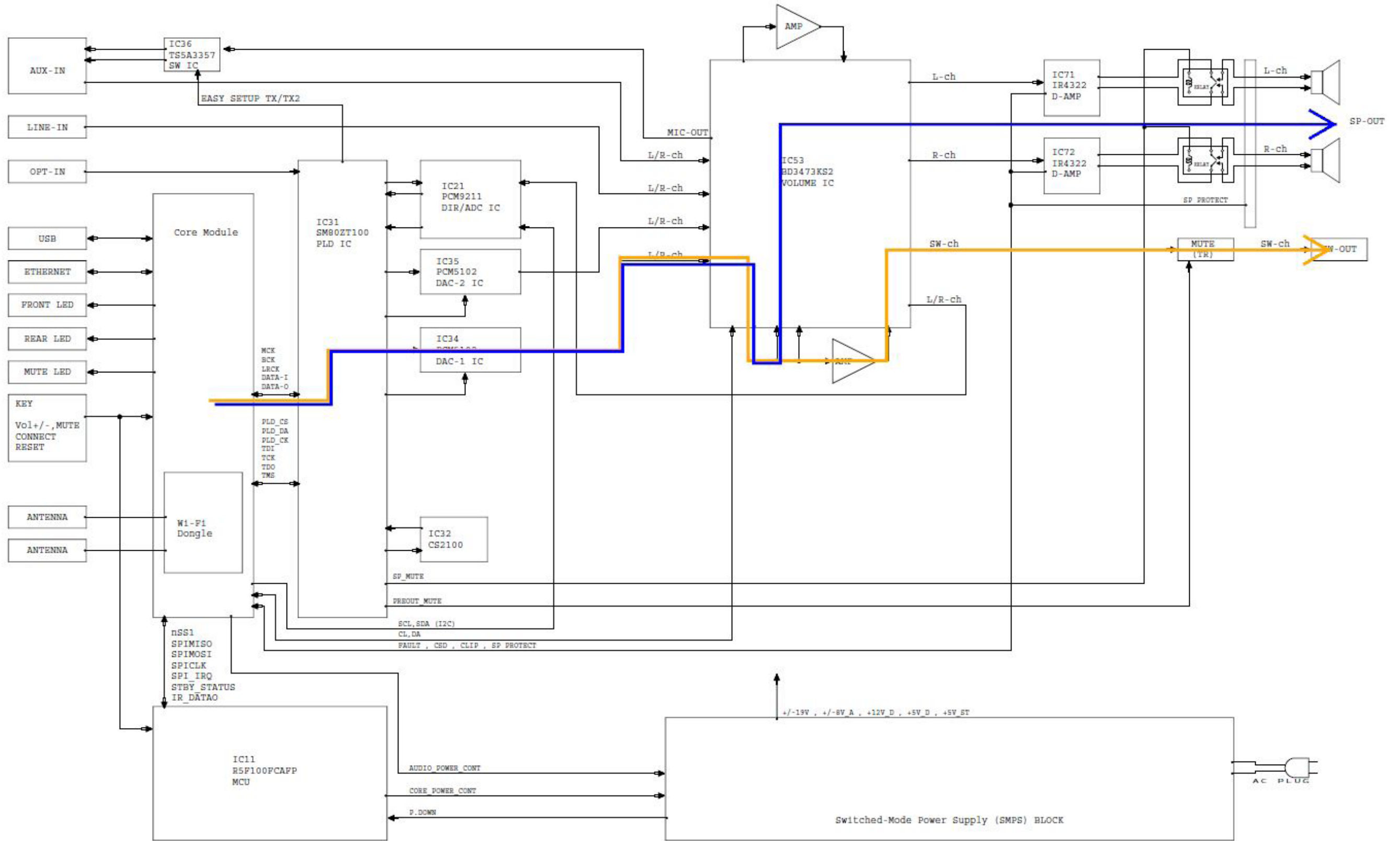

# BLOCK DIAGRAM

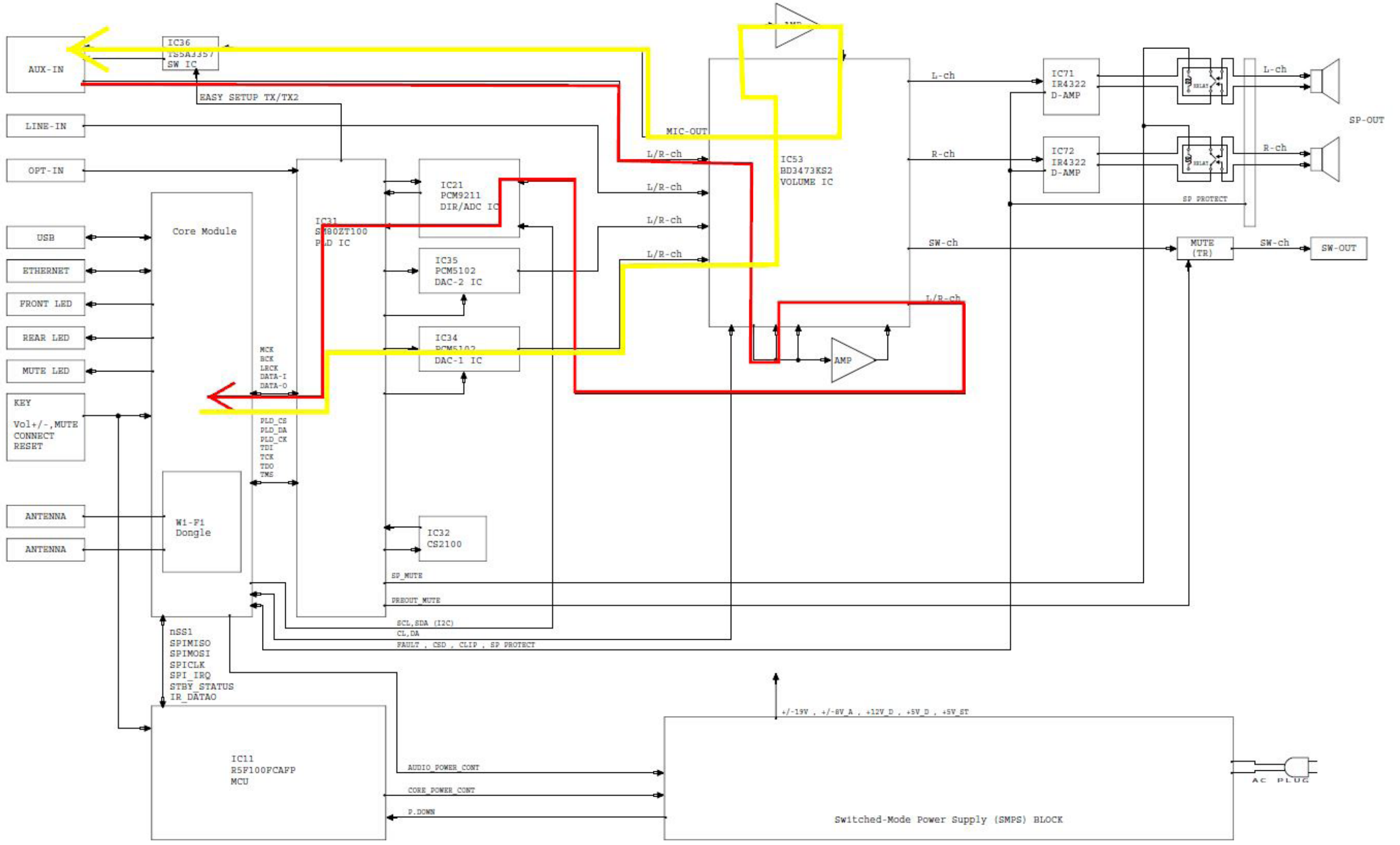

# MEASURING METHOD AND WAVEFORMS

## CUP12669Z-3 (CONNECT PCB)

BD3473KS2 Control Signal	
①	DA
②	CL

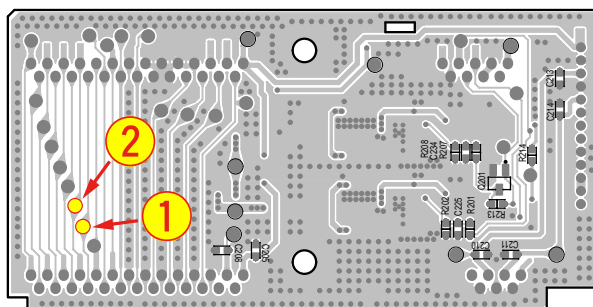

BD3473KS2 Control Signal

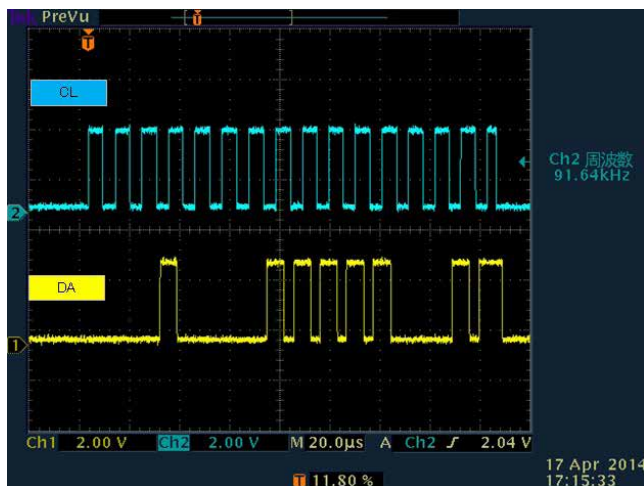

# 8U-110160-1 (PHONO/HDAM PCB)

PCM9211 Control Signal	
①	DA
②	CL

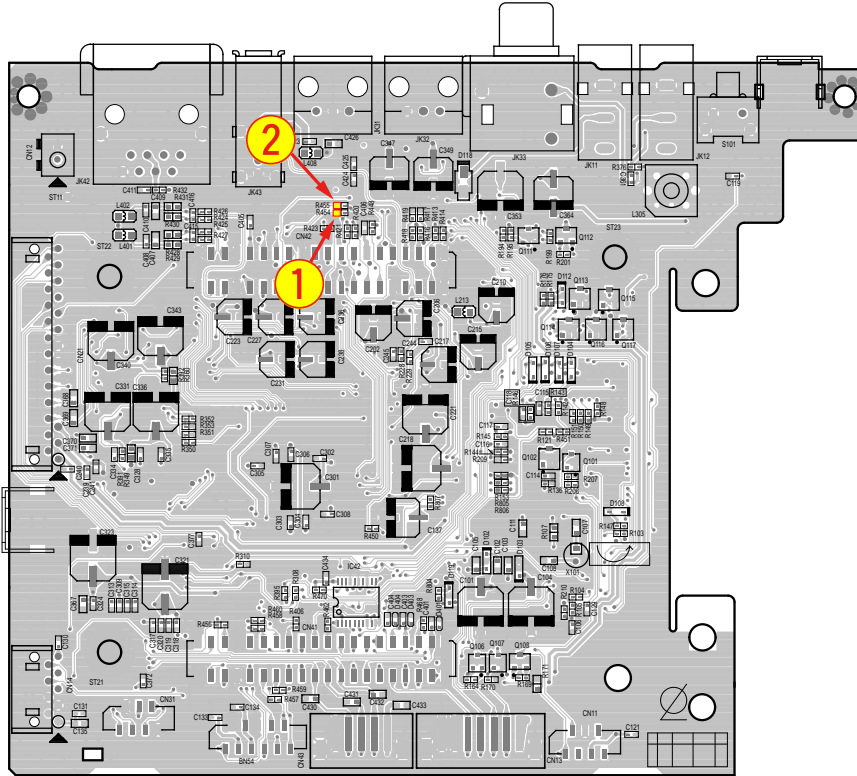

PCM9211 Control Signal

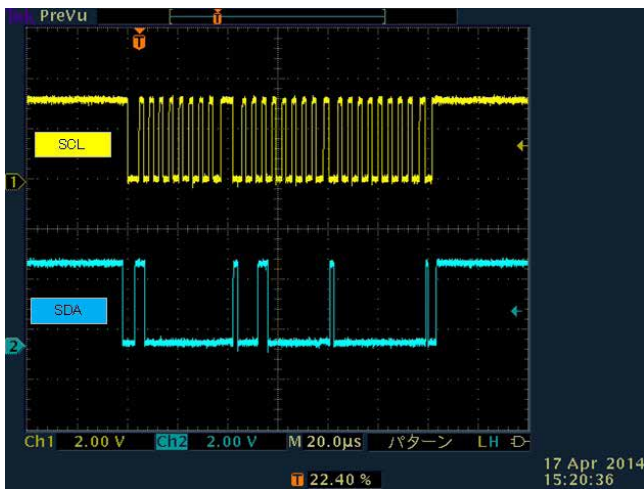





# BLOCK DIAGRAM

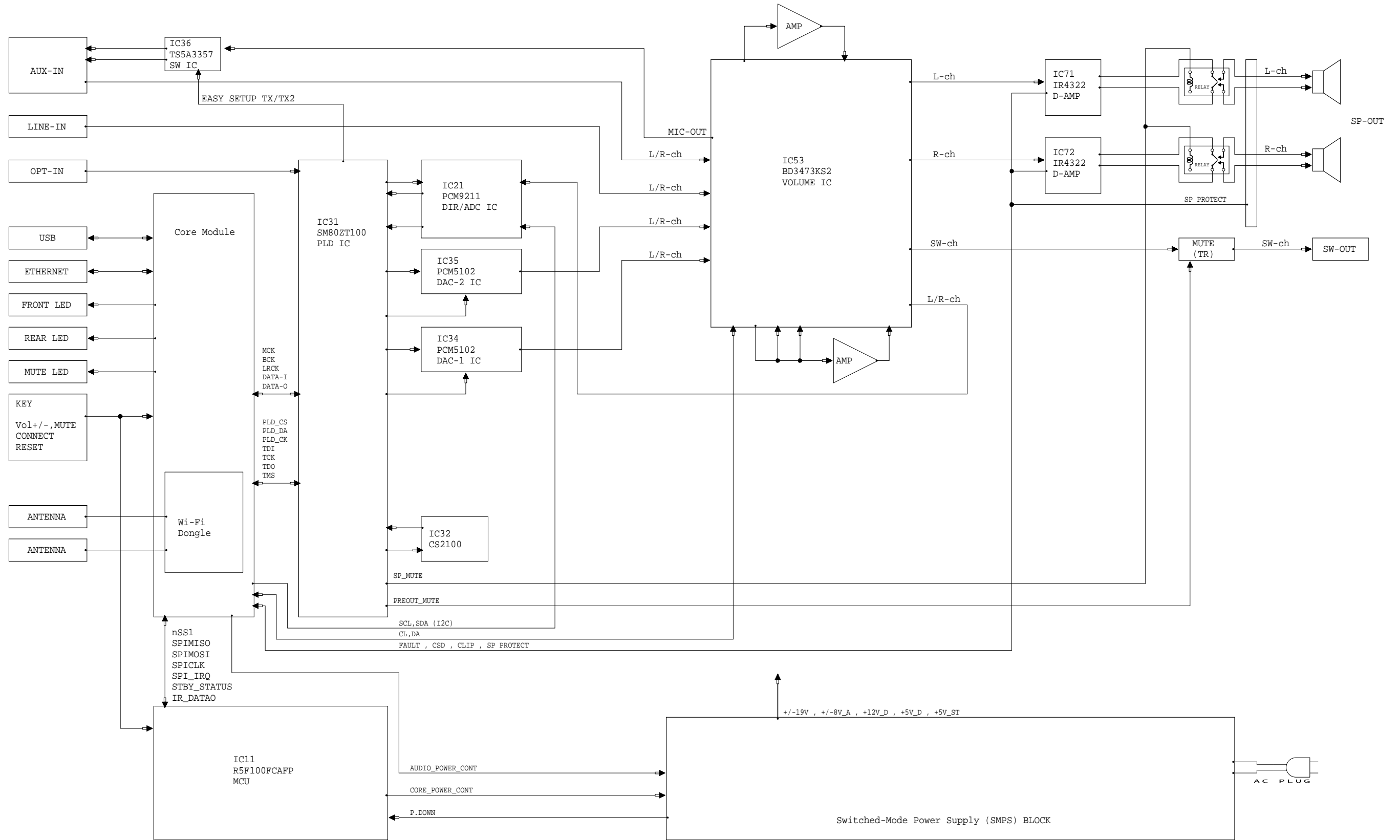

# POWER DIAGRAM

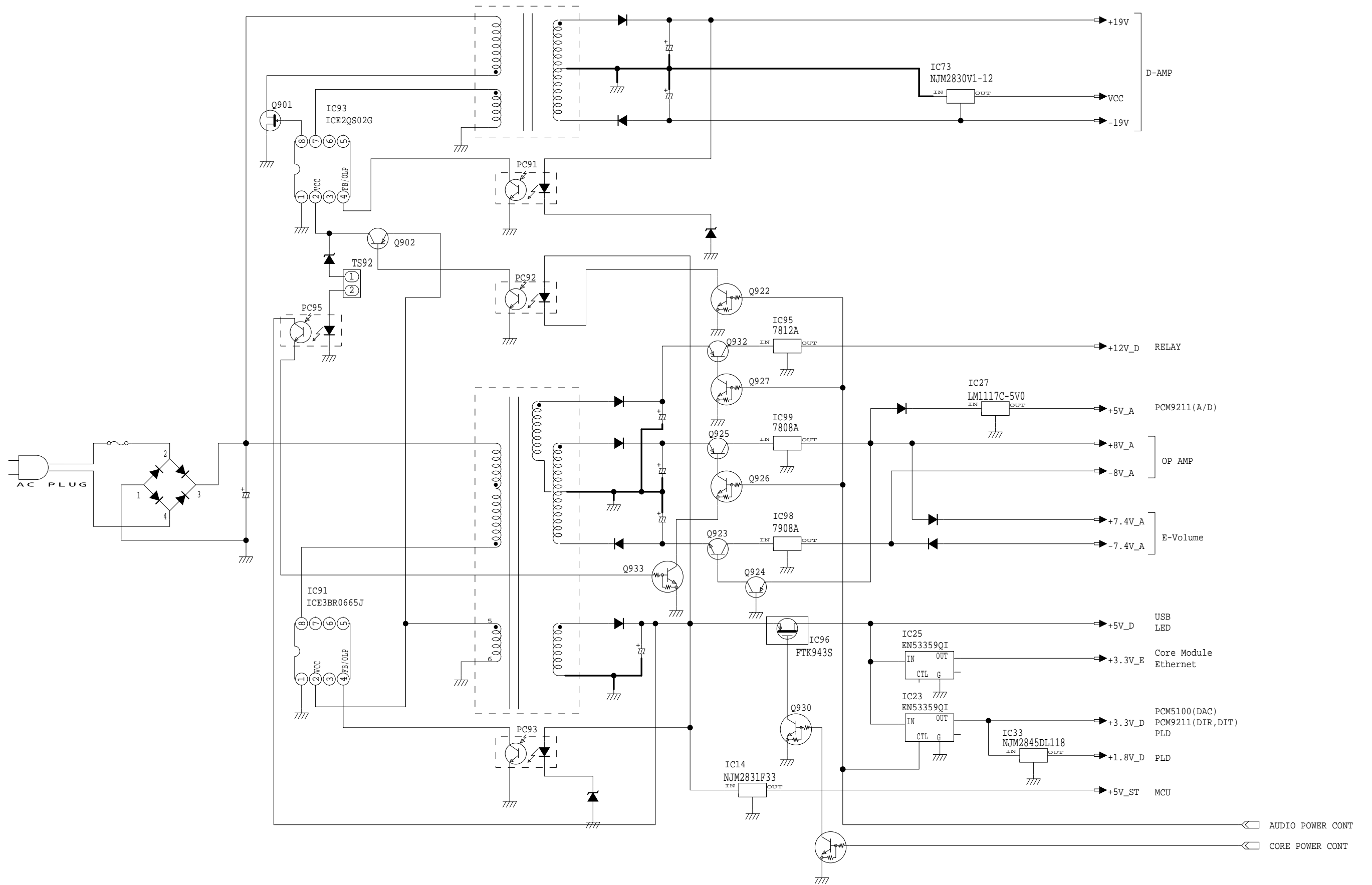





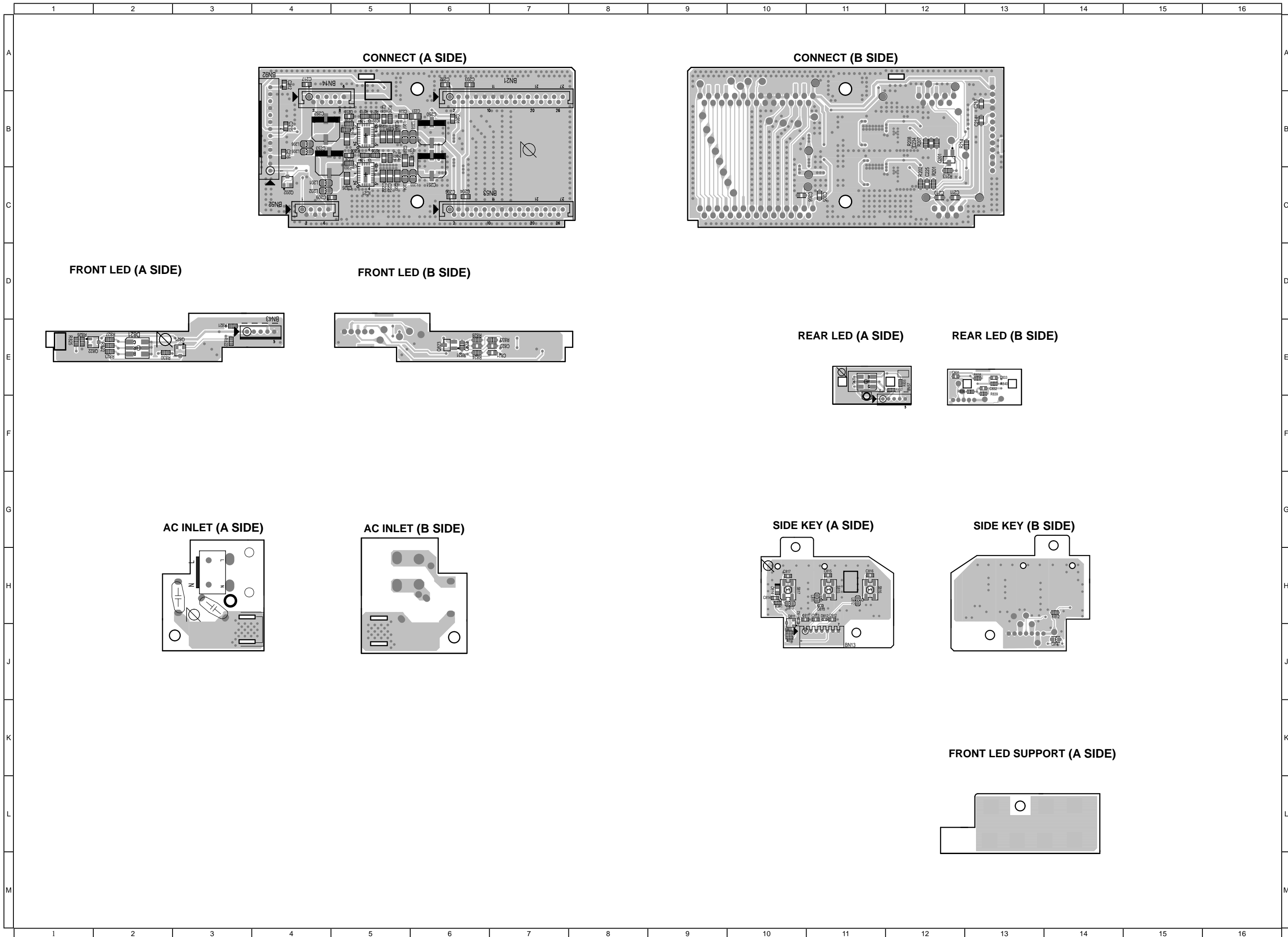

**CONNECT (A SIDE)**

**CONNECT (B SIDE)**

**FRONT LED (A SIDE)**

**FRONT LED (B SIDE)**

**REAR LED (A SIDE)**

**REAR LED (B SIDE)**

**AC INLET (A SIDE)**

**AC INLET (B SIDE)**

**SIDE KEY (A SIDE)**

**SIDE KEY (B SIDE)**

**FRONT LED SUPPORT (A SIDE)**

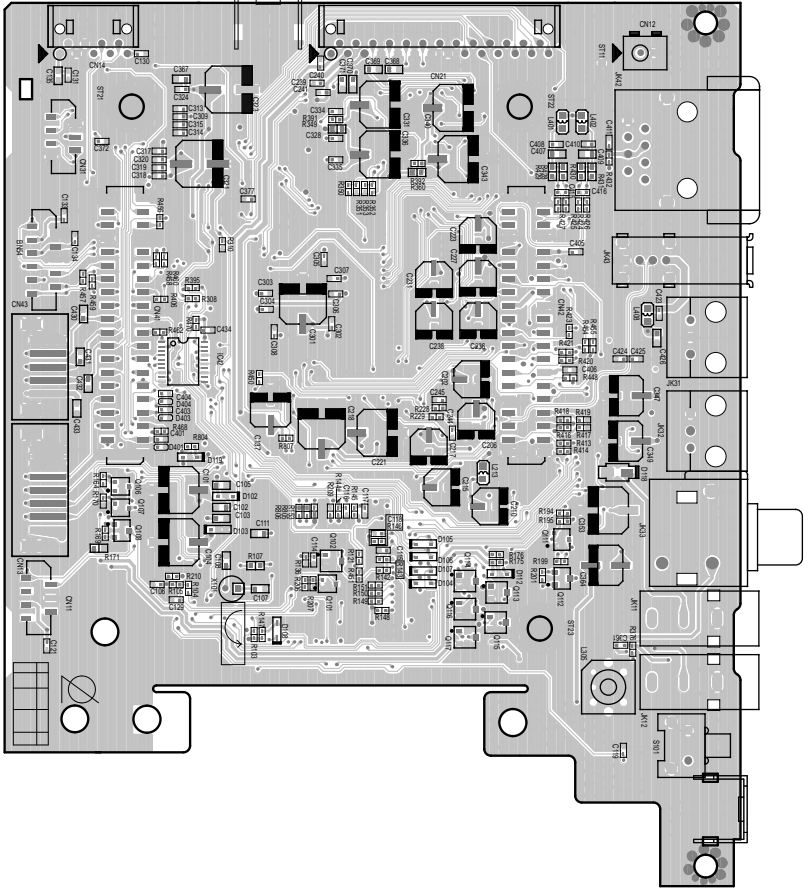
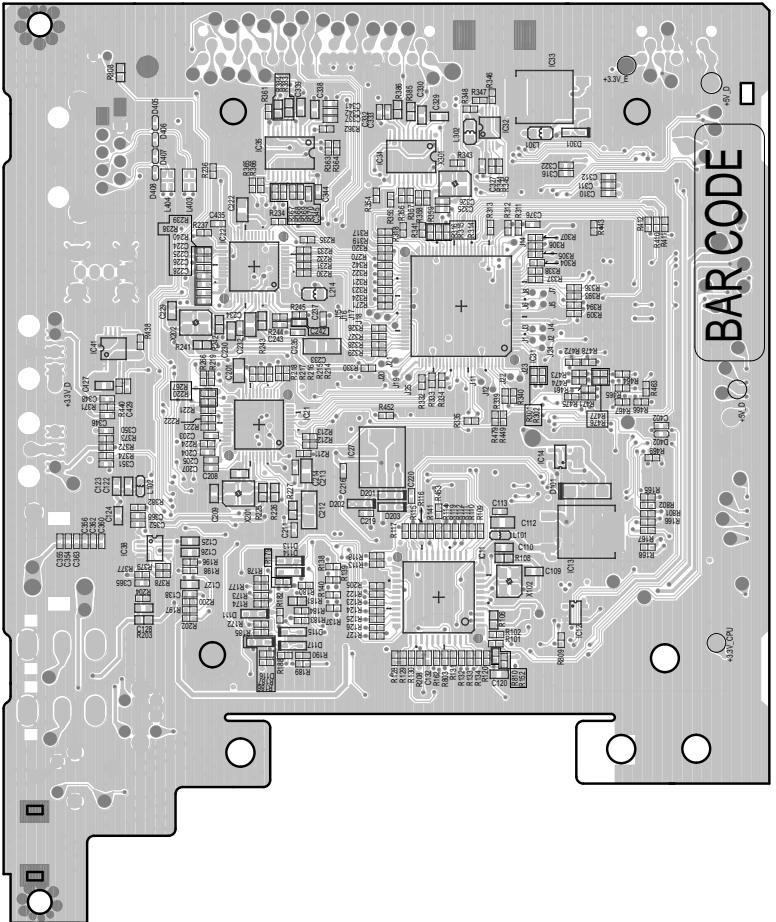
1	2	3	4	5	6	7	8	9	10	11	12	13	14	15	16		
A	<b>DIGITAL(A SIDE)</b>							<b>DIGITAL (B SIDE)</b>									A
B																	B
C																	C
D																	D
E																	E
F																	F
G																	G
H																	H
J																	J
K																	K
L																	L
M																	M
1	2	3	4	5	6	7	8	9	10	11	12	13	14	15	16		

**DIGITAL(A SIDE)**

**DIGITAL (B SIDE)**

**BAR CODE**







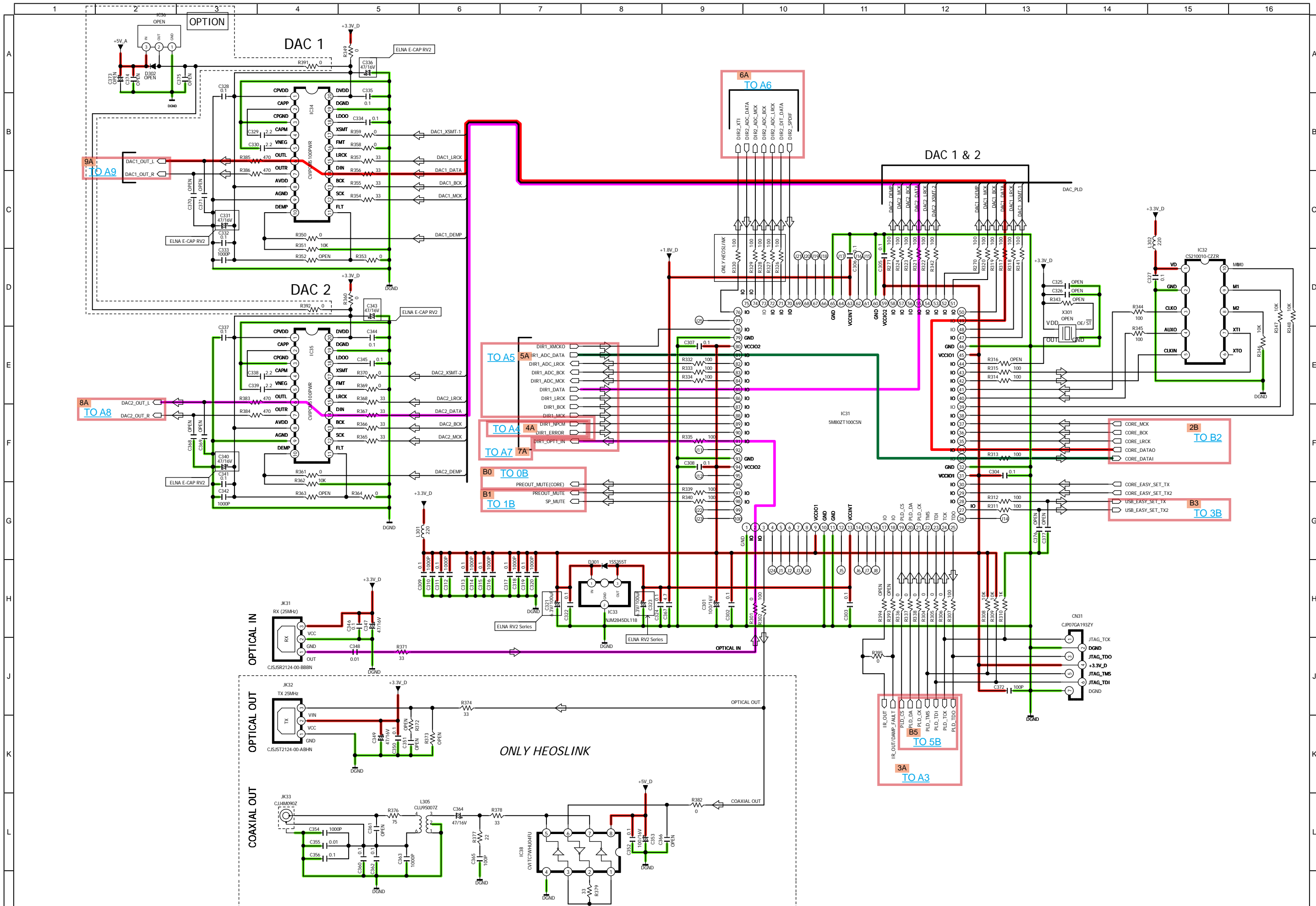

SCHEMATIC DIAGRAMS (3/7)  
DAMP

- GND LINE
- POWER+ LINE
- POWER- LINE
- STBY POWER
- SW Output
- LINE\_IN Playback
- AUX\_IN Playback (Common with LINE\_IN is in the middle)
- Digital Out
- Signal distribution path
- Digital In
- USB/Core
- MIC Route (Easy-Setup mode)

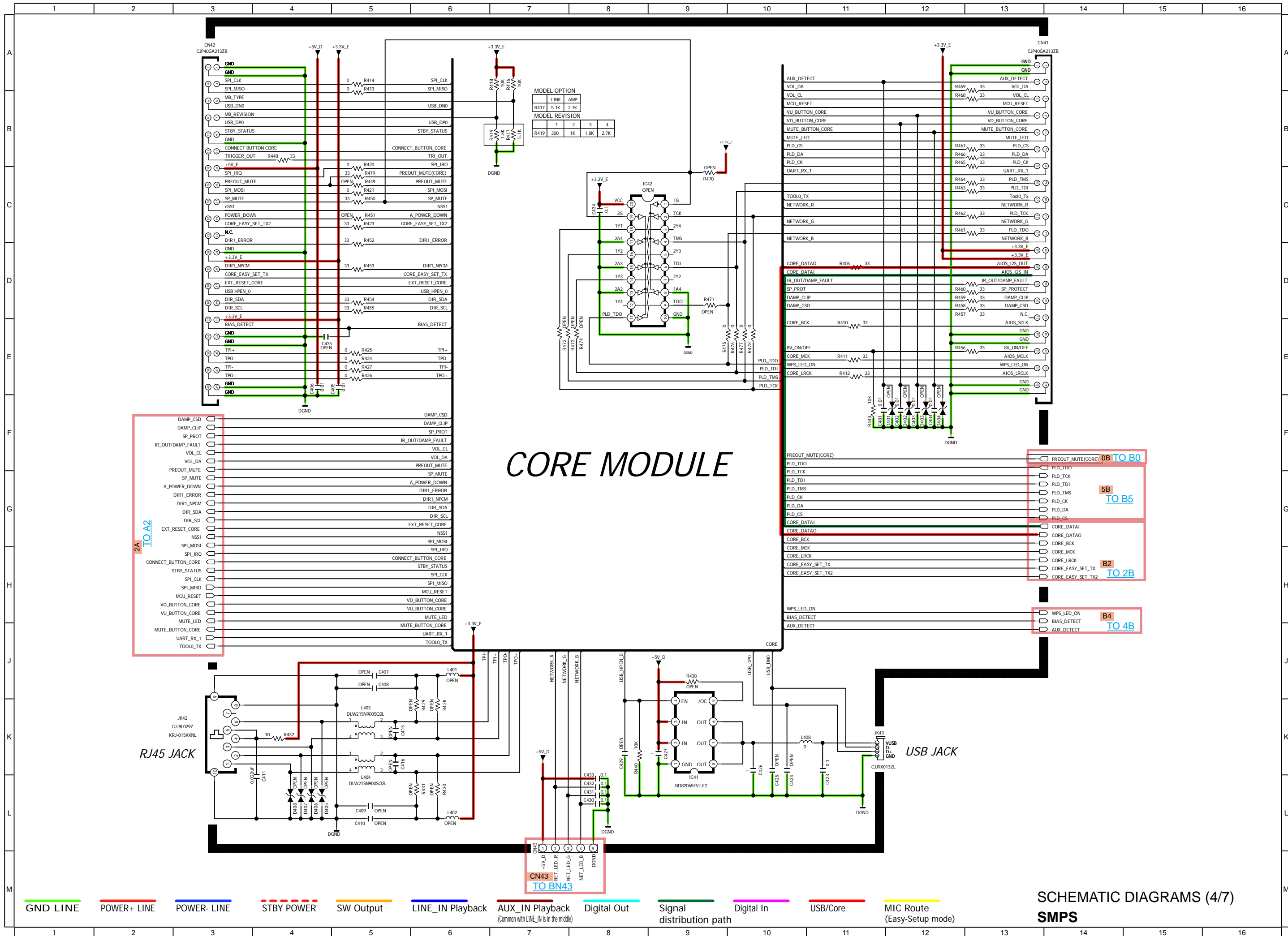

# CORE MODULE

# FUNCTION & VOLUME PART

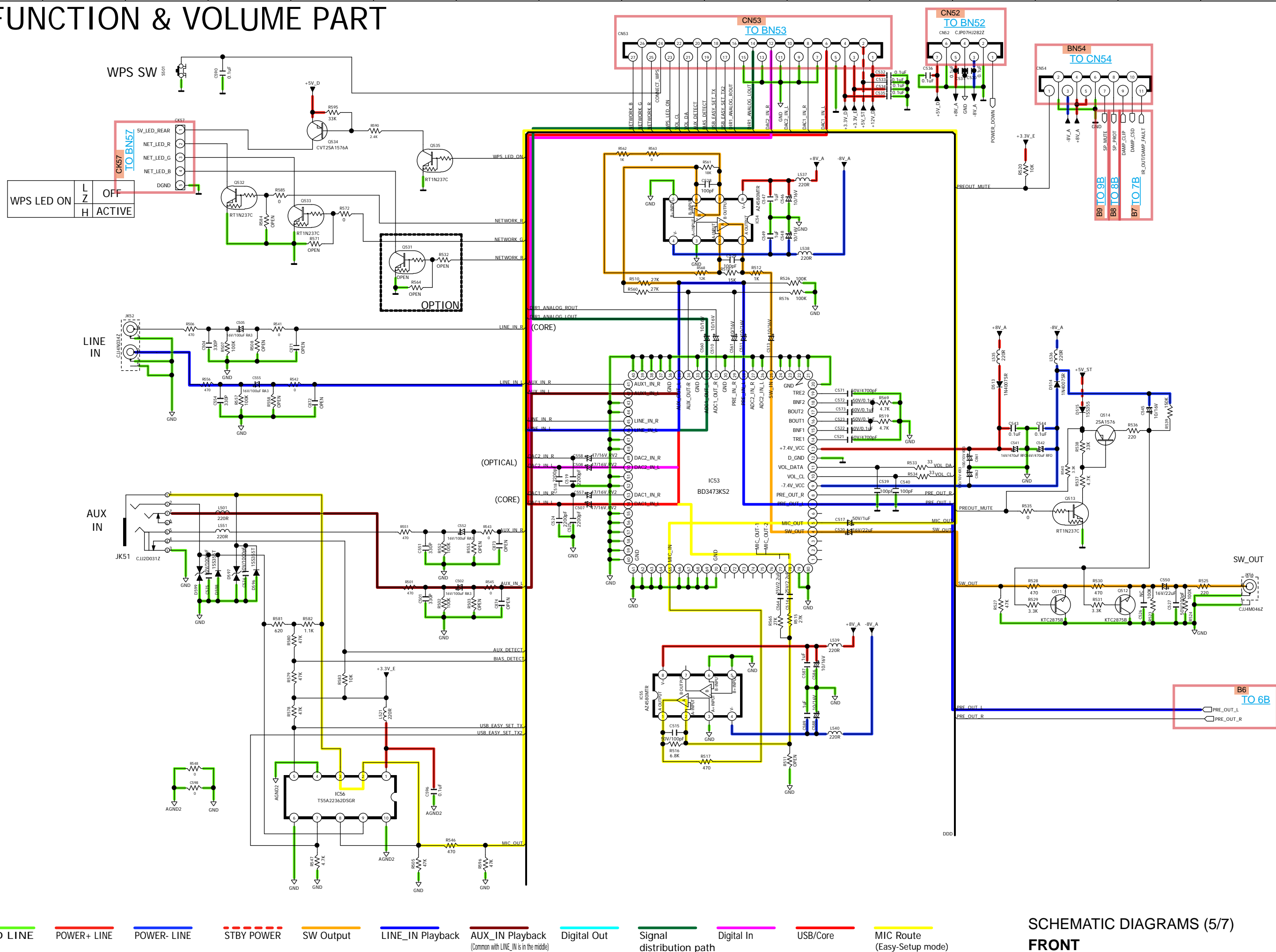

SCHMATIC DIAGRAMS (5/7)  
FRONT

# AMP PART

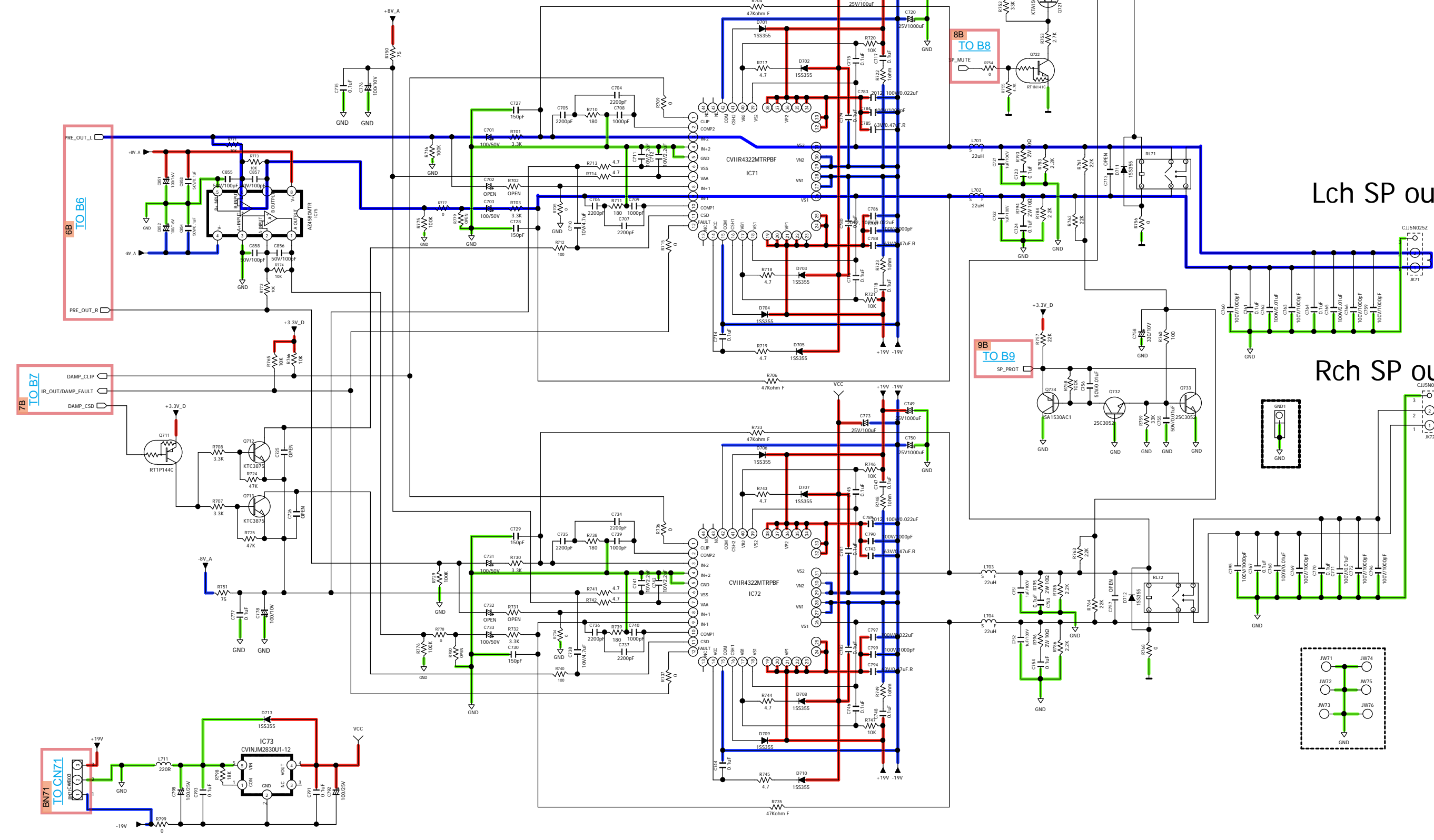

- GND LINE
- POWER+ LINE
- POWER- LINE
- STBY POWER
- SW Output
- LINE\_IN Playback
- AUX\_IN Playback  
(Common with LINE\_IN is in the middle)
- Digital Out
- Signal distribution path
- Digital In
- USB/Core
- MIC Route  
(Easy-Setup mode)

**SCHEMATIC DIAGRAMS (6/7)**  
**MAIN BT NFC KEY**

# SIDE KEY & LED(FRONT/REAR) PART

## SIDE KEY B'D

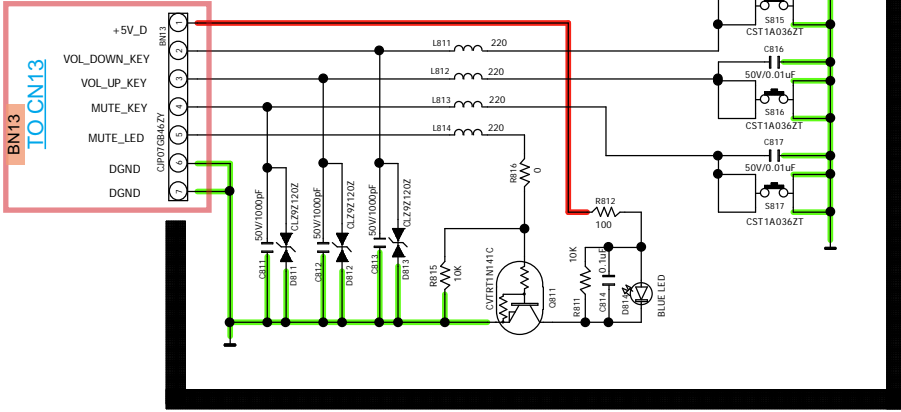

## FRONT LED B'D

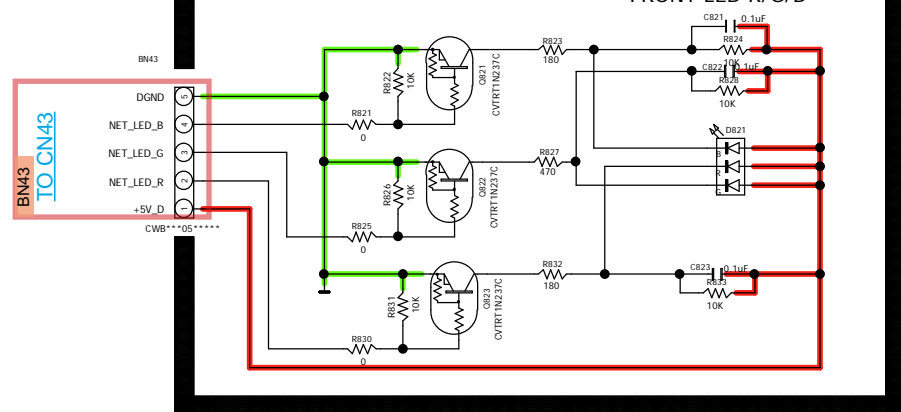

## REAR LED B'D

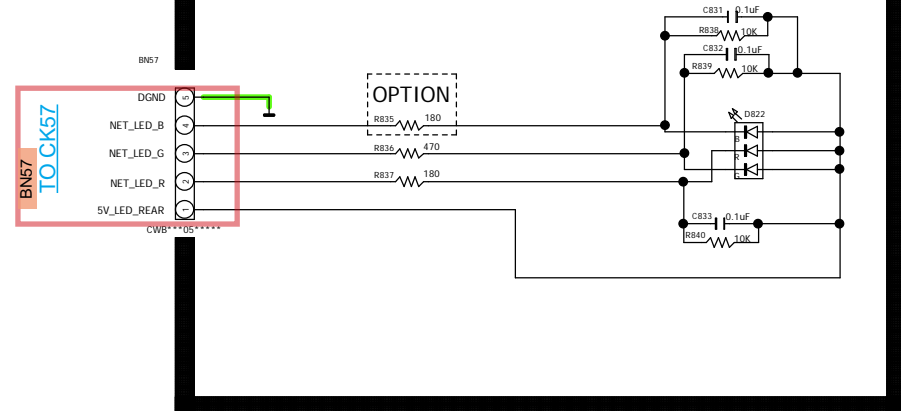

# CONNECTION B'D PART

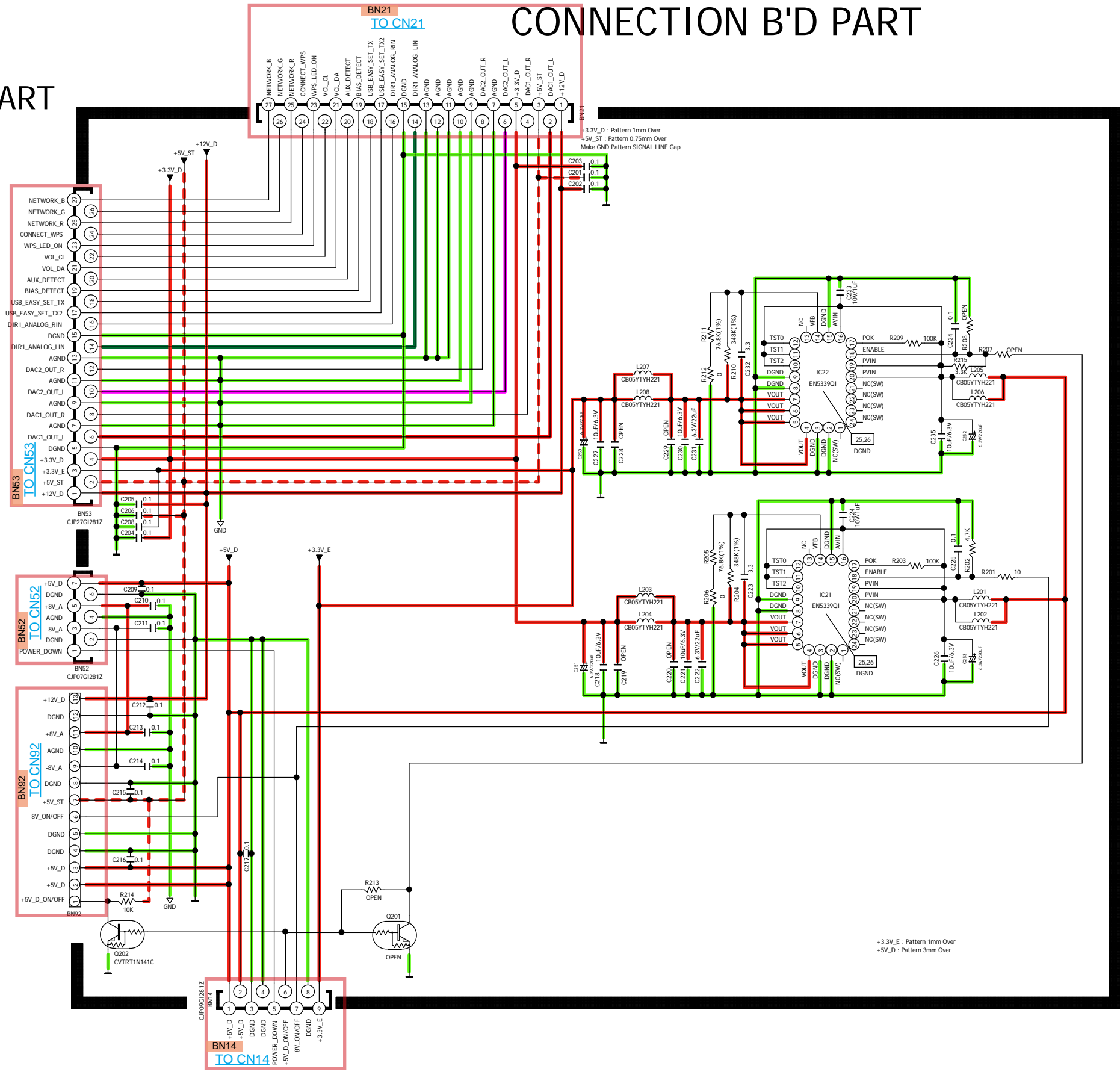

- GND LINE
- POWER+ LINE
- POWER- LINE
- STBY POWER
- SW Output
- LINE\_IN Playback
- AUX\_IN Playback  
(Common with LINE\_IN is in the middle)
- Digital Out
- Signal distribution path
- Digital In
- USB/Core
- MIC Route  
(Easy-Setup mode)

SCHEMATIC DIAGRAMS (7/7)  
TOUCH PAD

# SMPS SCHEMATIC DIAGRAM

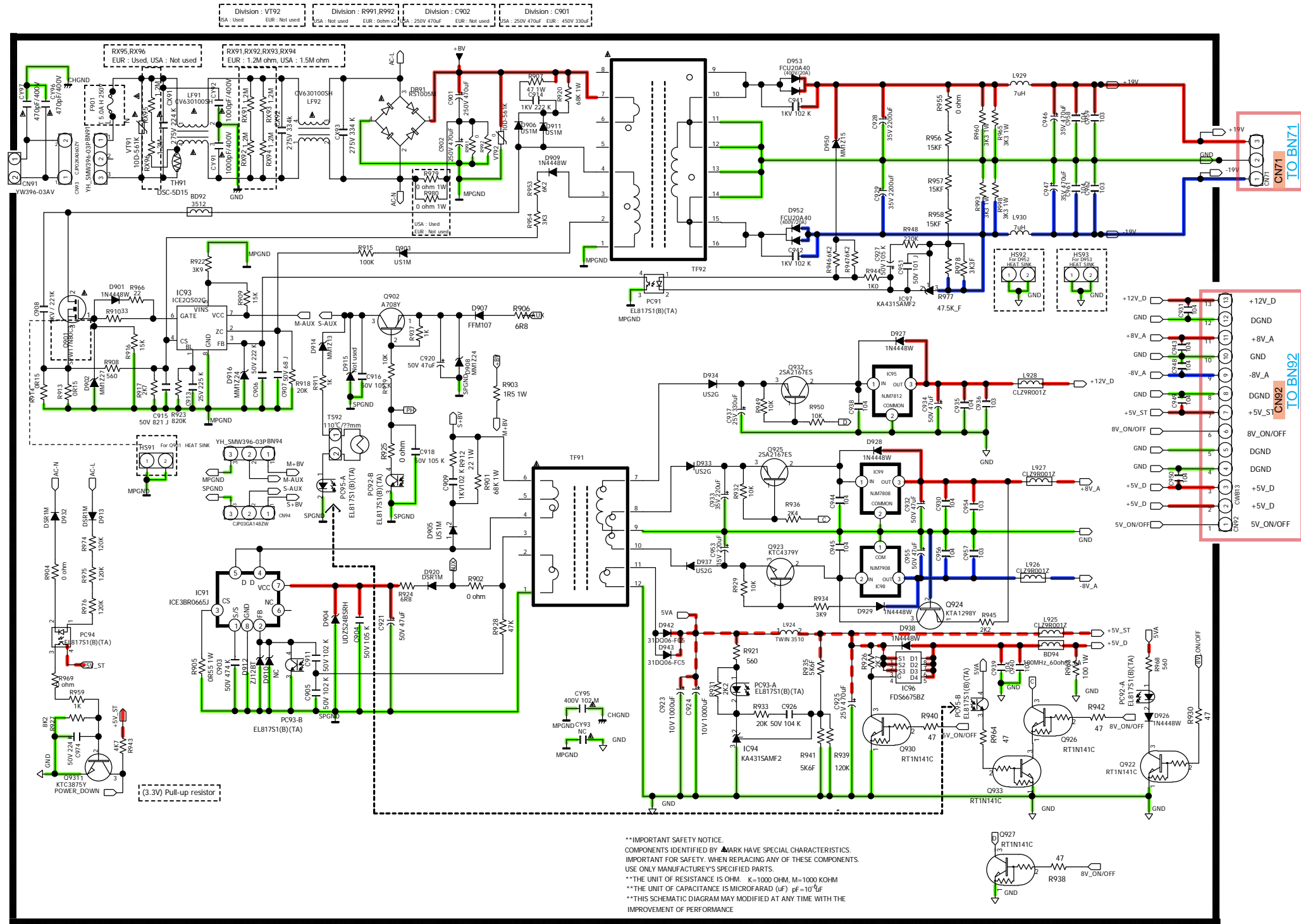

\*\*IMPORTANT SAFETY NOTICE.  
 COMPONENTS IDENTIFIED BY MARK HAVE SPECIAL CHARACTERISTICS.  
 IMPORTANT FOR SAFETY. WHEN REPLACING ANY OF THESE COMPONENTS,  
 USE ONLY MANUFACTURER'S SPECIFIED PARTS.  
 \*\*THE UNIT OF RESISTANCE IS OHM. K=1000 OHM, M=1000 KOHM  
 \*\*THE UNIT OF CAPACITANCE IS MICROFARAD (uF) pF=10<sup>-6</sup>uF  
 \*\*THIS SCHEMATIC DIAGRAM MAY BE MODIFIED AT ANY TIME WITH THE  
 IMPROVEMENT OF PERFORMANCE

# EXPLODED VIEW

See the last chapter the part list.

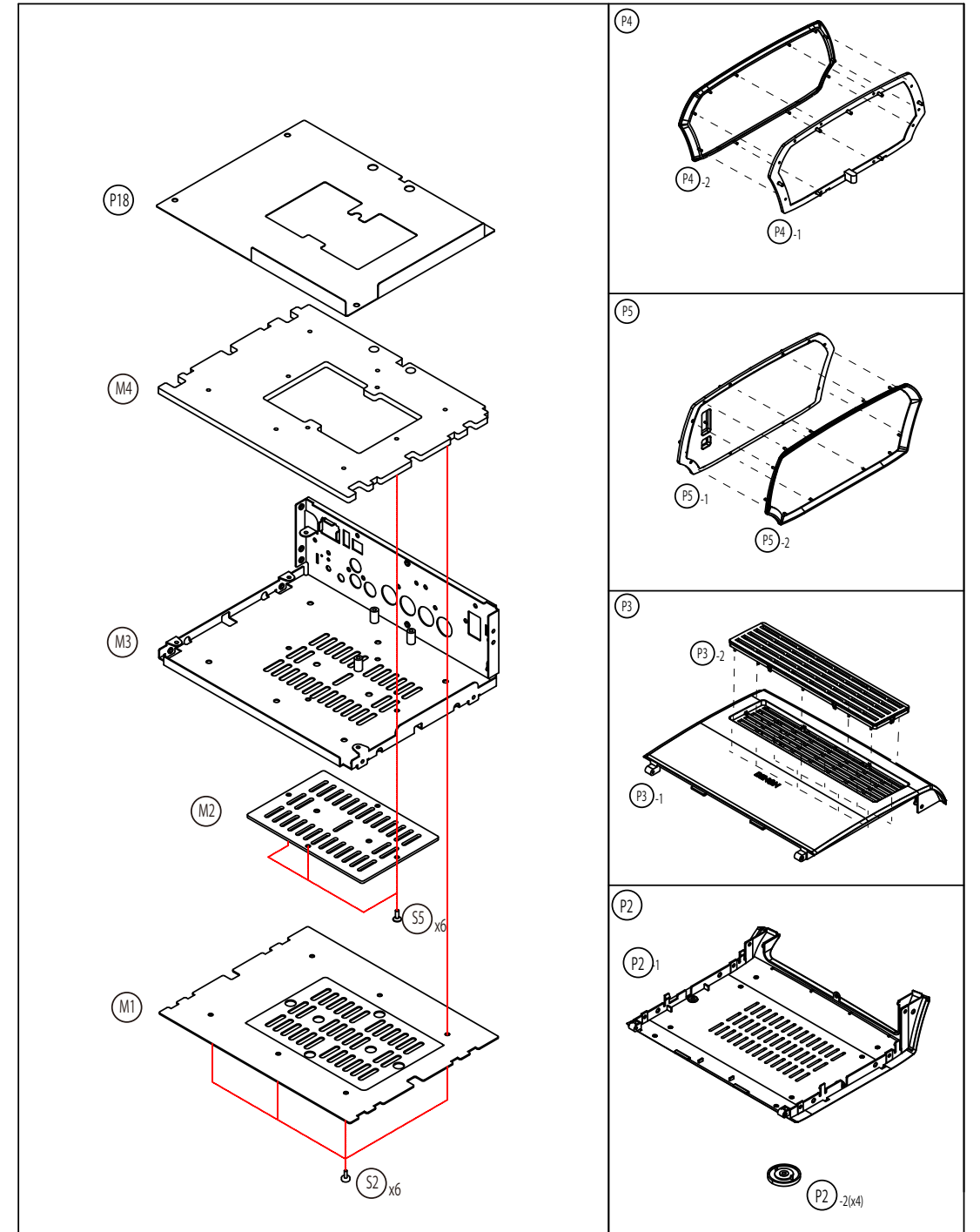
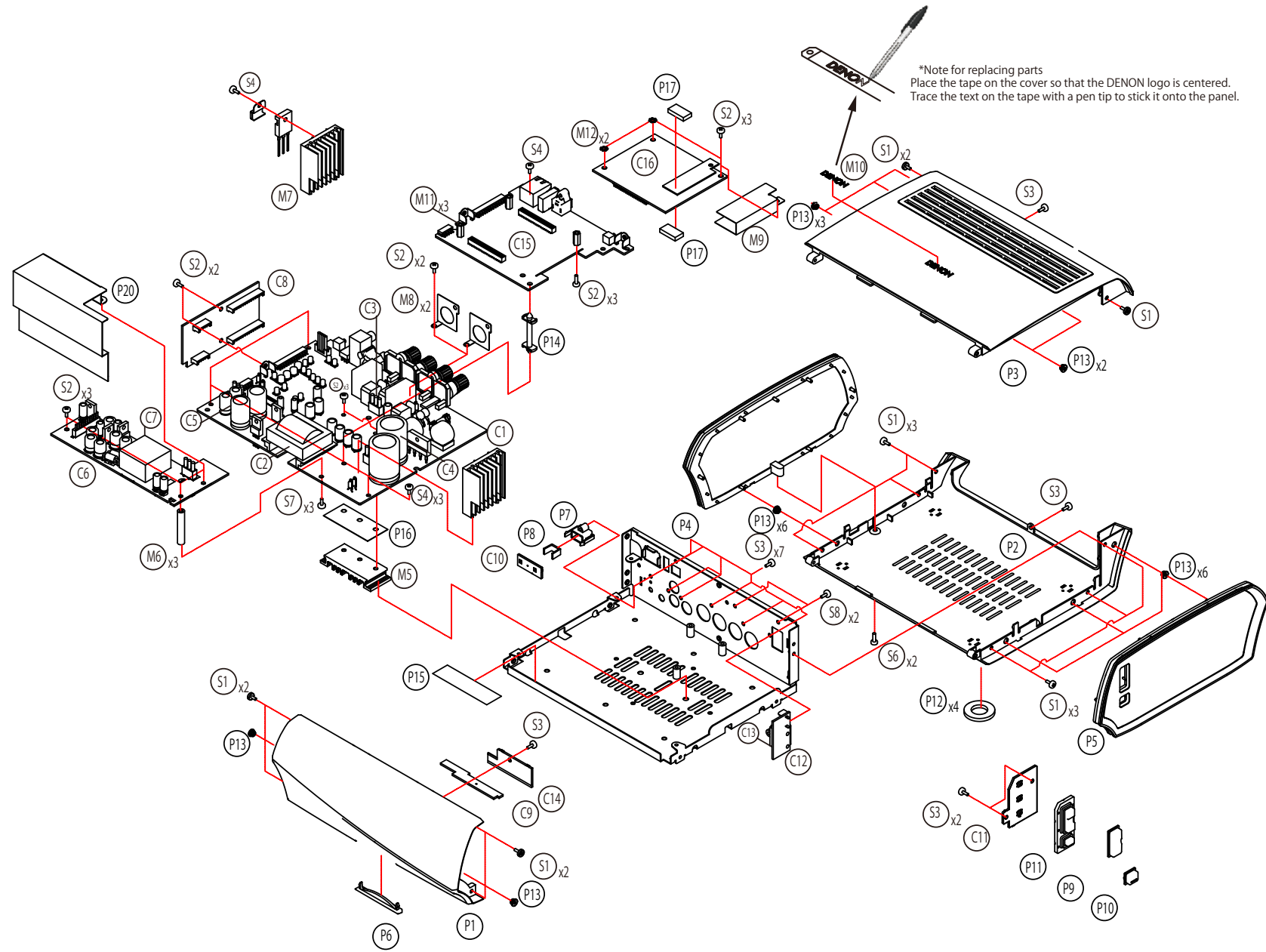

**WARNING:**  
Parts marked with this symbol  have critical characteristics.  
Use ONLY replacement parts recommended by the manufacturer.





# PACKING VIEW

Please refer to the last chapter for the part list.

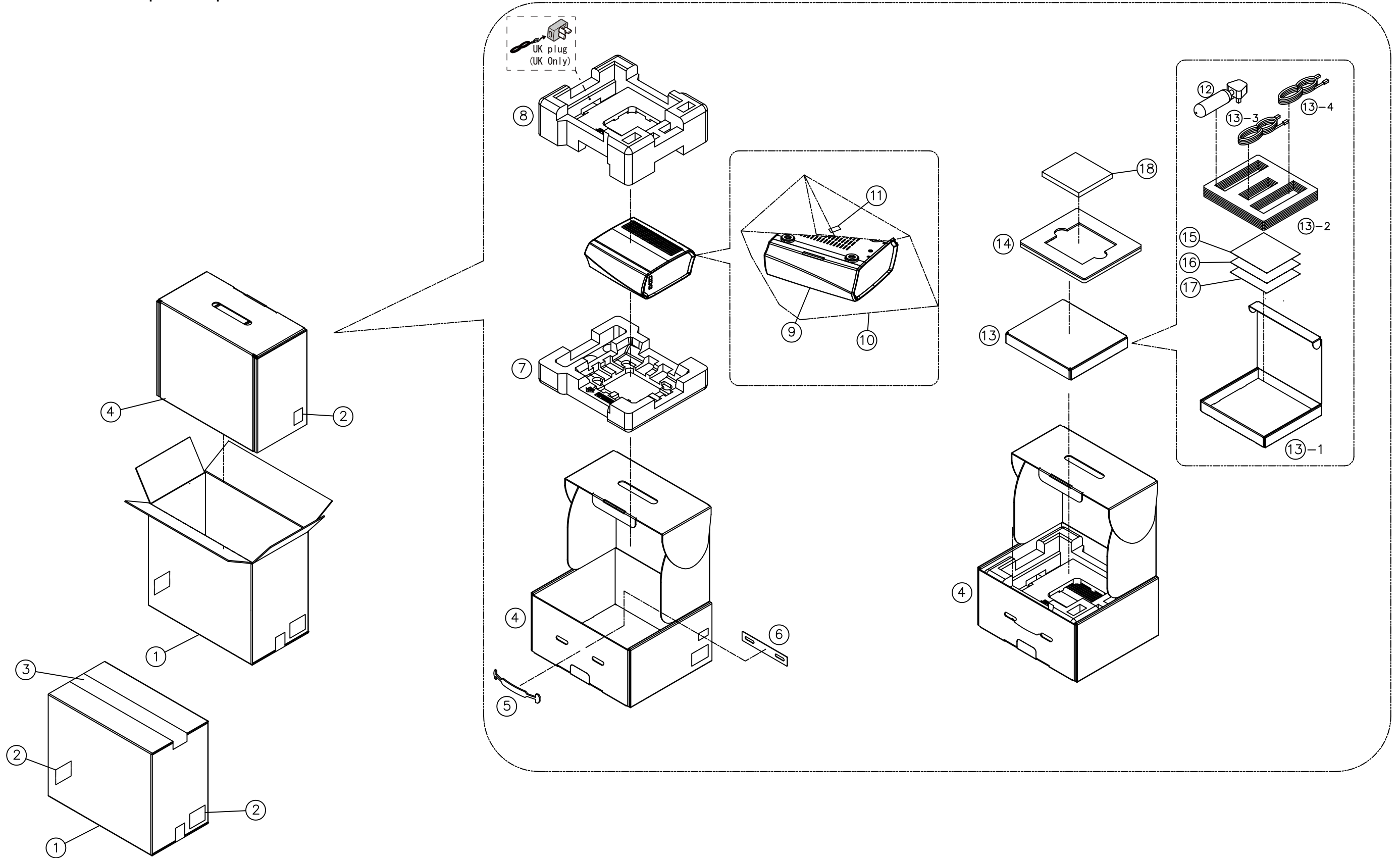

# SEMICONDUCTORS

Only major semiconductors are shown, general semiconductors etc. are omitted to list.  
 The semiconductor which described a detailed drawing in a schematic diagram are omitted to list.

## 1. IC's

### R5F100FCAFP (DIGITAL : IC11)

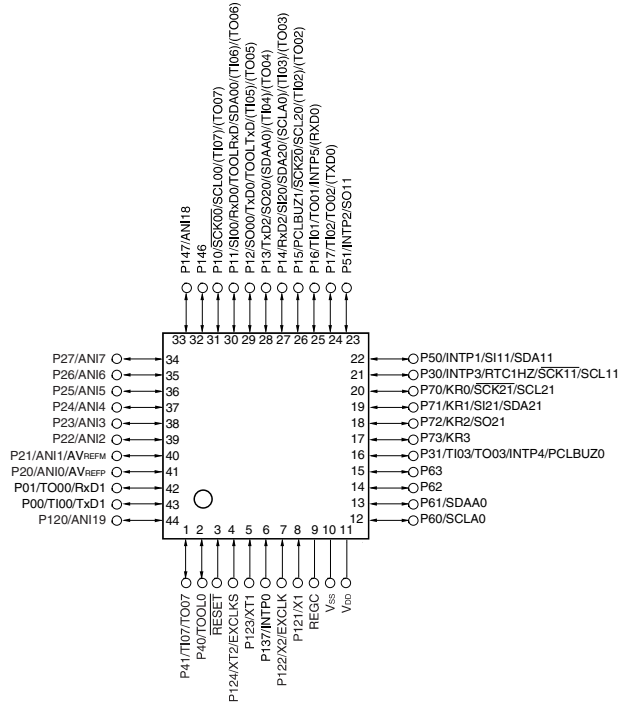

### R5F100FCAFP Block Diagram

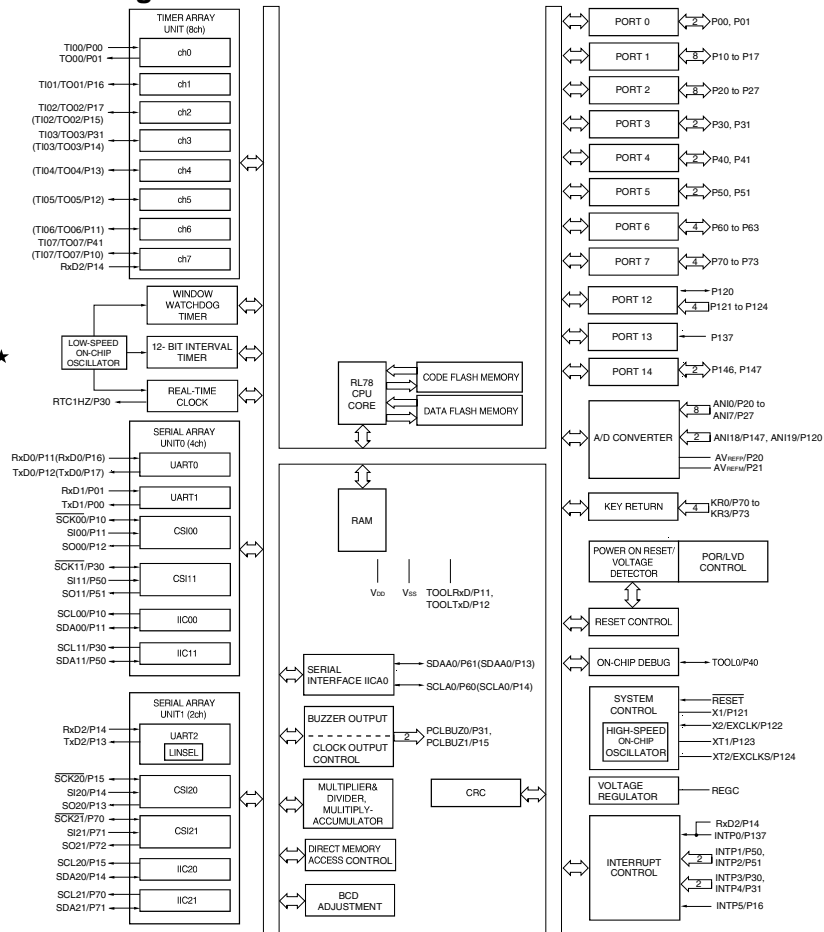

## R5F100FCAFP (44pinQFP)

Pin	Pin Name	Link	AMP	Symbol	Function
		I/O	I/O		
1	P41/TI07/TO07	I	←	CLIP	Unused
2	P40/TOOL0	I/O	←	TOOL0	update
3	_RESET	I	←	nRESET	Reset
4	P124/XT2/EXCLKS	-	←	XT2	-
5	P123/XT1		←	XT1	-
6	P137/INTP0	I	←	nSS1	SPI chip select (AIOS: Output) H: Not selected L: Selected
7	P122/X2/EXCLK	-	←	X2	-
8	P121/X1	-	←	X1	-
9	REGC	-	←	REGC	-
10	VSS	-	←	GND	-
11	VDD	-	←	Vdd	-
12	P60/SCLA0	I	←	MCU_SDA1	Unused
13	P61/SDAA0	I	←	MCU_SCL1	Unused
14	P62	I	←	CL	Unused
15	P63	I	←	DA	Unused
16	P31/TI03/TO03/INTP4/PCLBUZ0	I	←	SP PROTECT DETECT	Unused
17	P73/KR3	I	←	NPCM	Unused
18	P72/KR2/SO21	I	←	MODEL_SEL	"H" : DWP "L" : DWA
19	P71/KR1/SI21/SDA21	I	←	MUTE_BUTTON	"MUTE" button H: Not pressed L: Pressed
20	P70/KR0/_SCK21/SCL21	I	←	TDI	Unused
21	P30/INTP3/RTC1HZ/_SCK11/ SCL11	I	←	P.DOWN	POWER DOWN DETECT
22	P50/INTP1/SI11/SDA11	I	←	VOLUP_BUTTON	"VOL+" button H: Not pressed L: Pressed
23	P51/INTP2/SO11	I	←	VOLDOWN_ BUTTON	"VOL-" button H: not pressed L: Pressed
24	P17/TI02/TO02/TXD0	I	←	CONNECT_ BUTTON	"Connect (WPS)" button H: Not pressed L: Pressed
25	P16/TI01/TO01/INTP5/RXD0	I	←	DC PROTECT	Power Fault Detect
26	P15/PCLBUZ1/_SCK20/SCL20/ TI02/TO02	I	←	PLD_CK	Unused
27	P14/RxD2/SI20/SDA20/SCLA0/ TI03/TO03	O	←	Core Power ON/ OFF	H: Deep STB input L: Power on
28	P13/TxD2/SO20/SDAA0/TI04/TO04	I	←	TCK	Unused
29	P12/SO00/TxD0/TOOLTxD/TI05/ TO05	O	←	SPIMISO	SPI Tx data Data Output (AIOS: Input)
30	P11/SI00/RxD0/TOOLRxD/SDA00/ TI06/TO06	I	←	SPIMOSI	SPI Rx data Data Input(AIOS: Output)
31	P10/_SCK00/SCL00/TI07/TO07	I	←	SPICLK	SPI Clock input (AIOS: Output)
32	P146	I	←	TDO	Unused
33	P147/ANI18	O	←	SPI_IRQ	SPI read request Low means request.
34	P27/ANI7	I	←	STBY_STATUS	AIOS Standby status. Rising edge means "DeepStandby" entering.
35	P26/ANI6	I	←	CSD	Unused
36	P25/ANI5	I	←	TMS	Unused
37	P24/ANI4	I	←	ERROR	Unused

38	P23/ANI3	I	←	PLD_DA	Unused
39	P22/ANI2	I	←	Audio Power ON/ OFF	Unused
40	P21/ANI1/AVREFM	I	←	Trigger cont	Unused
41	P20/ANI0/AVREFP	I	←	JIG TACT SW	Unused
42	P01/TO00/RxD1	I	←	IR out/ FAULT	Unused
43	P00/TI00/TxD1	I	←	PLD_CS	Unused
44	P120/ANI19	O	←	EXT_RESET_ BUTTON	Unused

# BD3473KS2 (MAIN : IC53)

## 7.1ch Sound Processor

### ●General Description

It is 8ch independence volume which is the most suitable for the realization of 7.1ch surround system. Low shock noise switching was realized by Micro-Step Volume. 12 single-end input selector can cope with it to the zone 3, dual-multi input selectors are built in, and many sources of signal can be connected. Moreover, 2 band equalizer characters can be changed freely by changing outside parts.

### ●Features

- 12 single end input selectors are built-in (Possible maximum 18 single end with exclusion)
- Low shock noise switching was realized by Micro-Step Volume
- Zone 3 is possible
- Dual-multi input selectors are built-in
- 2 wire control copes with 3.3/5 V

### ●Applications

- Most suitable for the AV receiver, home theater system

### ●Key Specifications

- Total harmonic distortion: 0.0004%(Typ.)
- Maximum output voltage: 4.2V(Typ.)
- Output noise voltage: 1.5uVrms(Typ.)
- Residual output noise voltage: 1.0uVrms(Typ.)
- Cross-talk between channels: -105dB(Typ.)
- Cross-talk between selectors: -105dB(Typ.)

### ●Package

SQFP-T80C

W(Typ.) x D(Typ.) x H(Max.)

16.00mm x 16.00mm x 1.70mm



SQFP-T80C

### ●Typical Application Circuit

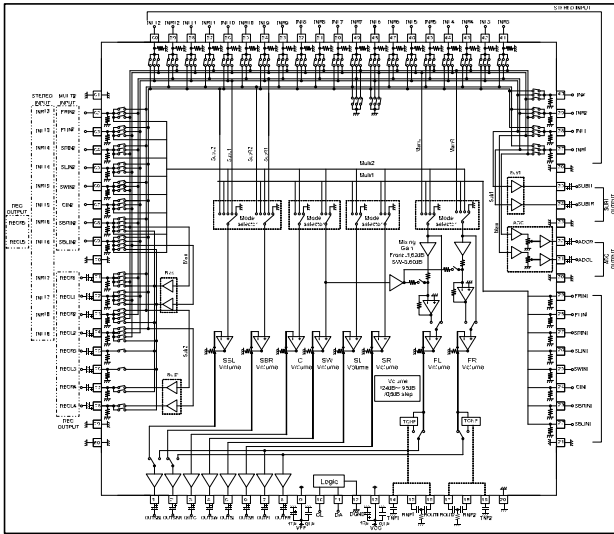

Figure 1. Application Circuit

### ●Pin Configuration(s)

SQFP-T80C  
(TOP VIEW)

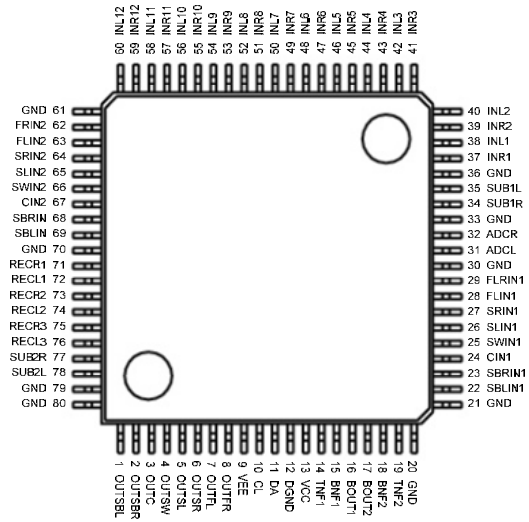

Figure 2. Pin configuration

●Description of terminal

Terminal Number	Symbol	Function	Terminal Number	Symbol	Function	Terminal Number	Symbol	Function	Terminal Number	Symbol	Function
1	OUTSBL	SBLch Output terminal	21	GND	Analog ground terminal	41	INR3	Rch input terminal 3	61	GND	Analog ground terminal
2	OUTSBR	SBRch Output terminal	22	SBLIN1	SBLch input terminal for DSP	42	INL3	Lch input terminal 3	62	FRIN2	FRch input terminal for DVD
3	OUTC	Cch Output terminal	23	SBRIN1	SBRch input terminal for DSP	43	INR4	Rch input terminal 4	63	FLIN2	FLch input terminal for DVD
4	OUTSW	SWch Output terminal	24	CIN1	Cch input terminal for DSP	44	INL4	Lch input terminal 4	64	SRIN2	SRch input terminal for DVD
5	OUTSL	SLch Output terminal	25	SWIN1	SWch input terminal for DSP	45	INR5	Rch input terminal 5	65	SLIN2	SLch input terminal for DVD
6	OUTSR	SRch Output terminal	26	SLIN1	SLch input terminal for DSP	46	INL5	Lch input terminal 5	66	SWIN2	SWch input terminal for DVD
7	OUTFL	FLch Output terminal	27	SRIN1	SRch input terminal for DSP	47	INR6	Rch input terminal 6	67	CIN2	Cch input terminal for DVD
8	OUTFR	FRch Output terminal	28	FLIN1	FLch input terminal for DSP	48	INL6	Lch input terminal 6	68	SBRIN2	SBRch input terminal for DVD
9	VEE	Negative power supply terminal	29	FRIN1	FRch input terminal for DSP	49	INR7	Rch input terminal 7	69	SBLIN2	SBLch input terminal for DVD
10	CL	Clock input terminal	30	GND	Analog ground terminal	50	INL7	Lch input terminal 7	70	GND	Analog ground terminal
11	DA	Data and latch input terminal	31	ADCL	Lch output terminal to ADC	51	INR8	Rch input terminal 8	71	RECR1	Rch REC output terminal 1
12	DGND	Digital ground terminal	32	ADCR	Rch output terminal to ADC	52	INL8	Lch input terminal 8	72	RECL1	Lch REC output terminal 1
13	VCC	Positive power supply terminal	33	GND	Analog ground terminal	53	INR9	Rch input terminal 9	73	RECR2	Rch REC output terminal 2
14	TNF1	TNF1 terminal (NF)	34	SUB1R	Rch SUB1 Output terminal	54	INL9	Lch input terminal 9	74	RECL2	Lch REC output terminal 2
15	BNF1	BNF1 terminal (NF)	35	SUB1L	Lch SUB1 Output terminal	55	INR10	Rch input terminal 10	75	RECR3	Rch REC output terminal 3
16	BOUT1	BOUT1 terminal (OUT)	36	GND	Analog ground terminal	56	INL10	Lch input terminal 10	76	RECL3	Lch REC output terminal 3
17	BOUT2	BOUT2 terminal (OUT)	37	INR1	Rch input terminal 1	57	INR11	Rch input terminal 11	77	SUB2R	Rch SUB2 output terminal
18	BNF2	BNF2 terminal (NF)	38	INL1	Lch input terminal 1	58	INL11	Lch input terminal 11	78	SUB2L	Lch SUB2 output terminal
19	TNF2	TNF2 terminal (NF)	39	INR2	Rch input terminal 2	59	INR12	Rch input terminal 12	79	GND	Analog ground terminal
20	GND	Analog ground terminal	40	INL2	Lch input terminal 2	60	INL12	Lch input terminal 12	80	GND	Analog ground terminal

●Block Diagram

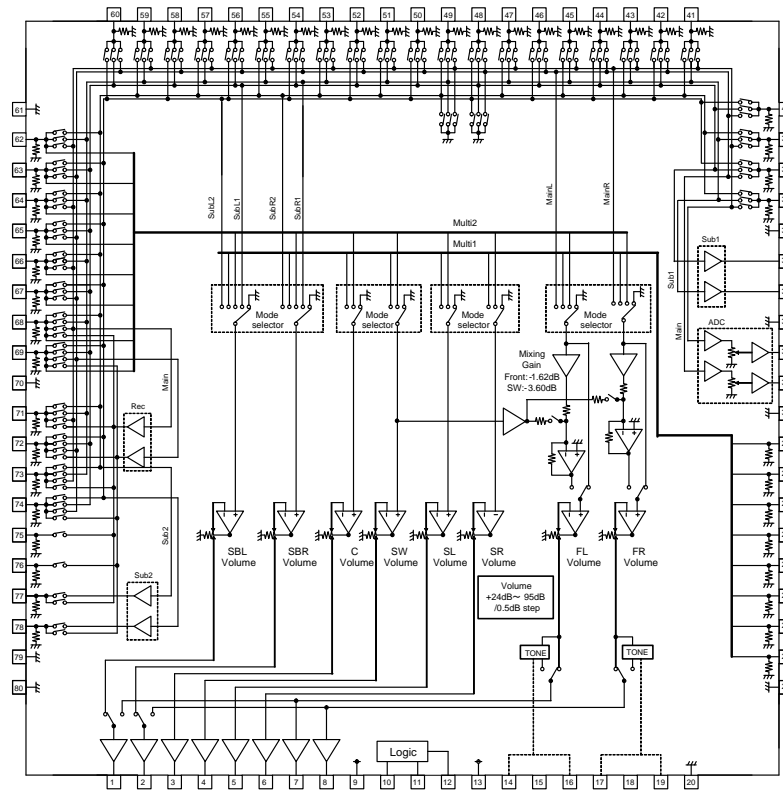
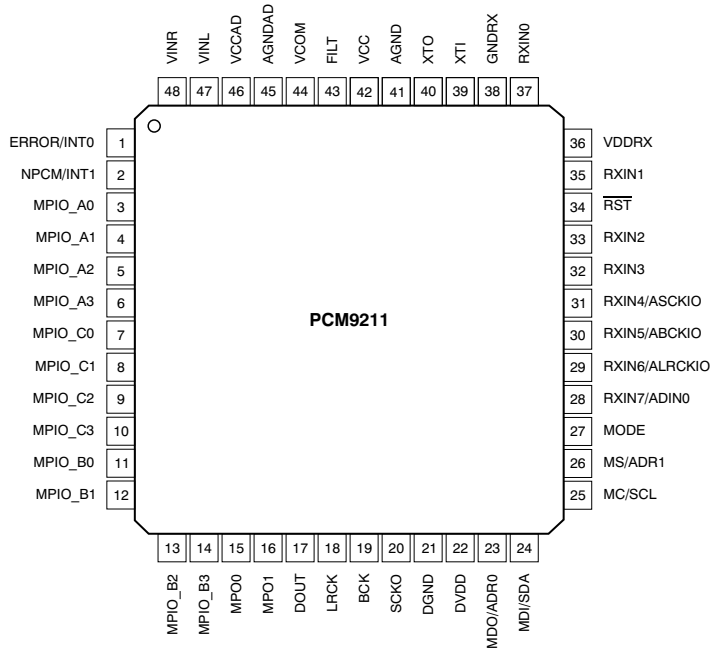
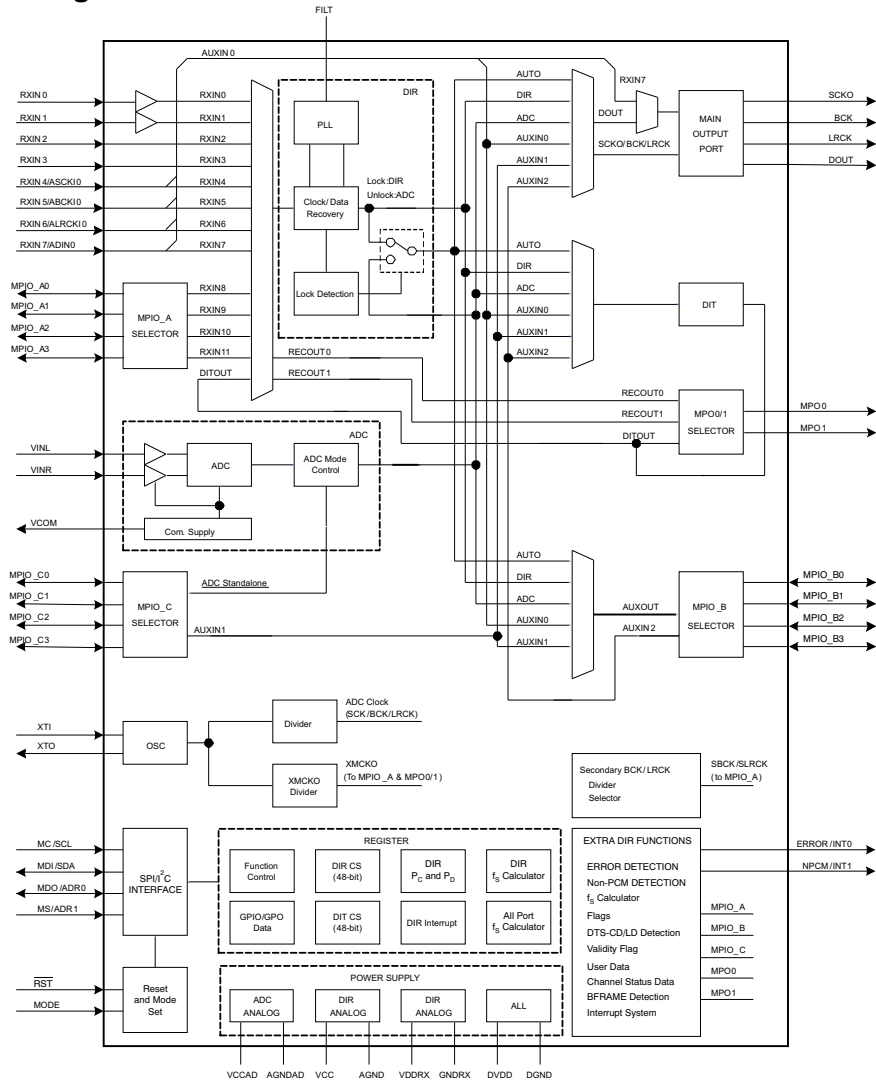

Figure 3. Block Diagram

# PCM9211 (DIGITAL : IC21)



# PCM9211 Block Diagram





## PCM9211 Pin Discriptions

NO.	PIN			DESCRIPTION
	NAME	I/O	5-V TOLERANT	
1	ERROR/INT0	O	No	DIR Error detection output / Interrupt0 output
2	NPCM/INT1	O	No	DIR Non-PCM detection output / Interrupt1 output
3	MPIO_A0	I/O	Yes	Multipurpose I/O, Group A(1)
4	MPIO_A1	I/O	Yes	Multipurpose I/O, Group A(1)
5	MPIO_A2	I/O	Yes	Multipurpose I/O, Group A(1)
6	MPIO_A3	I/O	Yes	Multipurpose I/O, Group A(1)
7	MPIO_C0	I/O	Yes	Multipurpose I/O, Group C(1)
8	MPIO_C1	I/O	Yes	Multipurpose I/O, Group C(1)
9	MPIO_C2	I/O	Yes	Multipurpose I/O, Group C(1)
10	MPIO_C3	I/O	Yes	Multipurpose I/O, Group C(1)
11	MPIO_B0	I/O	Yes	Multipurpose I/O, Group B(1)
12	MPIO_B1	I/O	Yes	Multipurpose I/O, Group B(1)
13	MPIO_B2	I/O	Yes	Multipurpose I/O, Group B(1)
14	MPIO_B3	I/O	Yes	Multipurpose I/O, Group B(1)
15	MPO0	O	No	Multipurpose output 0
16	MPO1	O	No	Multipurpose output 1
17	DOUT	O	No	Main output port, serial digital audio data output
18	LRCK	O	No	Main output port, LR clock output
19	BCK	O	No	Main output port, Bit clock output
20	SCKO	O	No	Main output port, System clock output
21	DGND	-	-	Ground, for digital
22	DVDD	-	-	Power supply, 3.3 V (typ.), for digital
23	MDO/ADR0	I/O	Yes	Software control I/F, SPI data output / I2C slave address setting0(2)
24	MDI/SDA	I/O	Yes	Software control I/F, SPI data input / I2C data input/output(2) (3)
25	MC/SCL	I	Yes	Software control I/F, SPI clock input / I2C clock input(2)
26	MS/ADR1	I	Yes	Software control I/F, SPI chip select / I2C slave address setting1(2)
27	MODE	I	No	Control mode setting, (see the Serial Control Mode section, Control Mode Pin Setting)
28	RXIN7/ADIN0	I	Yes	Biphase signal, input 7 / AUXIN0, serial audio data input(2)
29	RXIN6/ALRCKI0	I	Yes	Biphase signal, input 6 / AUXIN0, LR clock input(2)
30	RXIN5/ABCKI0	I	Yes	Biphase signal, input 5 / AUXIN0, bit clock input(2)
31	RXIN4/ASCKI0	I	Yes	Biphase signal, input 4 / AUXIN0, system clock input(2)
32	RXIN3	I	Yes	Biphase signal, input 3(2)
33	RXIN2	I	Yes	Biphase signal, input 2(2)
34	RST	I	Yes	Reset Input, active low(2) (4)
35	RXIN1	I	Yes	Biphase signal, input 1, built-in coaxial amplifier
36	VDDR_X	-	-	Power supply, 3.3 V (typ.), for RXIN0 and RXIN1.
37	RXIN0	I	Yes	Biphase signal, input 0, built-in coaxial amplifier
38	GNDRX	-	-	Ground, for RXIN
39	XTI	I	No	Oscillation circuit input for crystal resonator or external XTI clock source input(5)
40	XTO	O	No	Oscillation circuit output for crystal resonator
41	AGND	-	-	Ground, for PLL analog
42	VCC	-	-	Power supply, 3.3 V (typ.), for PLL analog
43	FILT	O	No	External PLL loop filter connection terminal; must connect recommended filter
44	VCOM	O	No	ADC common voltage output; must connect external decoupling capacitor
45	AGNDAD	-	-	Ground, for ADC analog
46	VCCAD	-	-	Power supply, 5.0 V (typ.), for ADC analog
47	VINL	I	No	ADC analog voltage input, left channel
48	VINR	I	No	ADC analog voltage input, right channel

(1) Schmitt trigger input

(2) Schmitt trigger input

(3) Open-drain configuration in I2C mode

(4) Onboard pull-down resistor (50 kΩ, typical)

(5) CMOS Schmitt trigger input

## PCM9211 Pin Discriptions

PIN				DESCRIPTION
NO.	NAME	I/O	5-V TOLERANT	
1	ERROR/INT0	O	No	DIR Error detection output / Interrupt0 output
2	NPCM/INT1	O	No	DIR Non-PCM detection output / Interrupt1 output
3	MPIO_A0	I/O	Yes	Multipurpose I/O, Group A <sup>(1)</sup>
4	MPIO_A1	I/O	Yes	Multipurpose I/O, Group A <sup>(1)</sup>
5	MPIO_A2	I/O	Yes	Multipurpose I/O, Group A <sup>(1)</sup>
6	MPIO_A3	I/O	Yes	Multipurpose I/O, Group A <sup>(1)</sup>
7	MPIO_C0	I/O	Yes	Multipurpose I/O, Group C <sup>(1)</sup>
8	MPIO_C1	I/O	Yes	Multipurpose I/O, Group C <sup>(1)</sup>
9	MPIO_C2	I/O	Yes	Multipurpose I/O, Group C <sup>(1)</sup>
10	MPIO_C3	I/O	Yes	Multipurpose I/O, Group C <sup>(1)</sup>
11	MPIO_B0	I/O	Yes	Multipurpose I/O, Group B <sup>(1)</sup>
12	MPIO_B1	I/O	Yes	Multipurpose I/O, Group B <sup>(1)</sup>
13	MPIO_B2	I/O	Yes	Multipurpose I/O, Group B <sup>(1)</sup>
14	MPIO_B3	I/O	Yes	Multipurpose I/O, Group B <sup>(1)</sup>
15	MPO0	O	No	Multipurpose output 0
16	MPO1	O	No	Multipurpose output 1
17	DOUT	O	No	Main output port, serial digital audio data output
18	LRCK	O	No	Main output port, LR clock output
19	BCK	O	No	Main output port, Bit clock output
20	SCKO	O	No	Main output port, System clock output
21	DGND	–	–	Ground, for digital
22	DVDD	–	–	Power supply, 3.3 V (typ.), for digital
23	MDO/ADR0	I/O	Yes	Software control I/F, SPI data output / I <sup>2</sup> C slave address setting <sup>(2)</sup>
24	MDI/SDA	I/O	Yes	Software control I/F, SPI data input / I <sup>2</sup> C data input/output <sup>(2)(3)</sup>
25	MC/SCL	I	Yes	Software control I/F, SPI clock input / I <sup>2</sup> C clock input <sup>(2)</sup>
26	MS/ADR1	I	Yes	Software control I/F, SPI chip select / I <sup>2</sup> C slave address setting <sup>(2)</sup>
27	MODE	I	No	Control mode setting, (see the Serial Control Mode section, Control Mode Pin Setting)
28	RXIN7/AUXIN0	I	Yes	Biphase signal, input 7 / AUXIN0, serial audio data input <sup>(2)</sup>
29	RXIN6/ALRCKI0	I	Yes	Biphase signal, input 6 / AUXIN0, LR clock input <sup>(2)</sup>
30	RXIN5/ABCKI0	I	Yes	Biphase signal, input 5 / AUXIN0, bit clock input <sup>(2)</sup>
31	RXIN4/ASCKI0	I	Yes	Biphase signal, input 4 / AUXIN0, system clock input <sup>(2)</sup>
32	RXIN3	I	Yes	Biphase signal, input 3 <sup>(2)</sup>
33	RXIN2	I	Yes	Biphase signal, input 2 <sup>(2)</sup>
34	RST	I	Yes	Reset Input, active low <sup>(2)(4)</sup>
35	RXIN1	I	Yes	Biphase signal, input 1, built-in coaxial amplifier
36	VDDR	–	–	Power supply, 3.3 V (typ.), for RXIN0 and RXIN1.
37	RXIN0	I	Yes	Biphase signal, input 0, built-in coaxial amplifier
38	GNDRX	–	–	Ground, for RXIN
39	XTI	I	No	Oscillation circuit input for crystal resonator or external XTI clock source input <sup>(5)</sup>
40	XTO	O	No	Oscillation circuit output for crystal resonator
41	AGND	–	–	Ground, for PLL analog
42	VCC	–	–	Power supply, 3.3 V (typ.), for PLL analog
43	FILT	O	No	External PLL loop filter connection terminal; must connect recommended filter
44	VCOM	O	No	ADC common voltage output; must connect external decoupling capacitor
45	AGNDAD	–	–	Ground, for ADC analog
46	VCCAD	–	–	Power supply, 5.0 V (typ.), for ADC analog
47	VINL	I	No	ADC analog voltage input, left channel
48	VINR	I	No	ADC analog voltage input, right channel

(1) Schmitt trigger input

(2) Schmitt trigger input

(3) Open-drain configuration in I<sup>2</sup>C mode

(4) Onboard pull-down resistor (50 kΩ, typical)

(5) CMOS Schmitt trigger input

**PCM5102 (DIGITAL : IC34,35)**

**PCM510X (top view)**

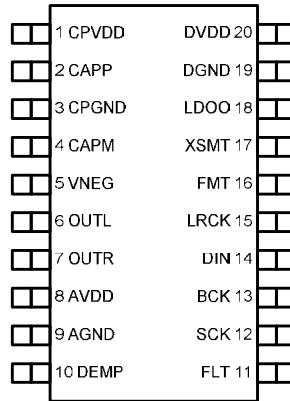
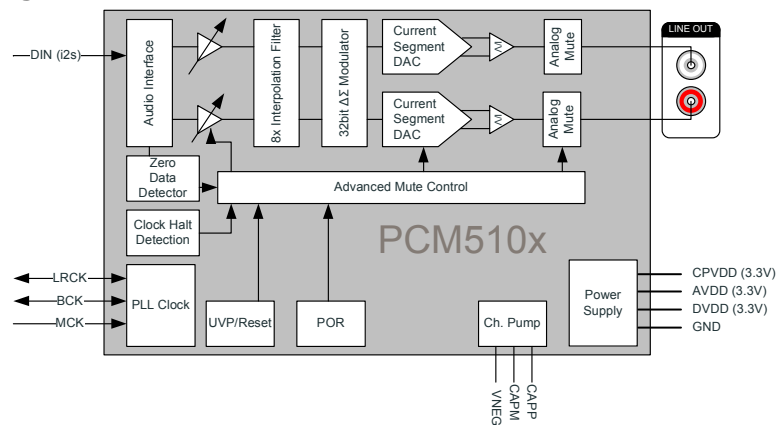

**Table 2. TERMINAL FUNCTIONS, PCM510x**

TERMINAL		I/O	DESCRIPTION
NAME	NO.		
CPVDD	1	-	Charge pump power supply, 3.3V
CAPP	2	O	Charge pump flying capacitor terminal for positive rail
CPGND	3	-	Charge pump ground
CAPM	4	O	Charge pump flying capacitor terminal for negative rail
VNEG	5	O	Negative charge pump rail terminal for decoupling, -3.3V
OUTL	6	O	Analog output from DAC left channel
OUTR	7	O	Analog output from DAC right channel
AVDD	8	-	Analog power supply, 3.3V
AGND	9	-	Analog ground
DEMP	10	I	De-emphasis control for 44.1kHz sampling rate <sup>(1)</sup> : Off (Low) / On (High)
FLT	11	I	Filter select : Normal latency (Low) / Low latency (High)
SCK	12	I	System clock input
BCK	13	I	Audio data bit clock input
DIN	14	I	Audio data input
LRCK	15	I	Audio data word clock input
FMT	16	I	Audio format selection : I <sup>2</sup> S (Low) / Left justified (High)
XSMT	17	I	Soft mute control : Soft mute (Low) / soft un-mute (High)
LDOO	18	-	Internal logic supply rail terminal for decoupling
DGND	19	-	Digital ground
DVDD	20	-	Digital power supply, 3.3V

(1) Failsafe LVCMOS Schmitt trigger input

**PCM5102 Block Diagram**



**Figure 1. PCM510x Functional Block Diagram**

# IR4322 (MAIN : IC71,72)

## Features

- ☒ 2 channel integrated analog input Class D audio amplifier in a small 7 x 7 mm PQFN44 package
- ☒ No mechanical heatsink required
- ☒ High peak music power output
- ☒ Split or single power supply
- ☒ Differential or single-ended input
- ☒ Over-current, over-temperature and under voltage protections with self-reset feature
- ☒ Start/stop click noise reduction
- ☒ Clip and Fault reporting outputs
- ☒ High noise immunity
- ☒ RoHS compliant

## Typical Applications

- ☒ Home theatre systems
- ☒ Docking station audio systems
- ☒ PC audio systems
- ☒ Musical instruments
- ☒ Karaoke amplifiers
- ☒ Game consoles
- ☒ Powered speaker systems
- ☒ General purpose audio power amplifiers

## Product Summary

Topology	Half-Bridge, Full-Bridge
IR4322 Output power (Typical, THD+N=10%)	100 W/ 4 Ω
	100 W/ 2 Ω
*Residual noise (AES-17, IHF-A, typical)	250 μVrms
*THD+N (1kHz, 1W, 4 Ω, typical)	0.02 %

\* In typical application example

## Package



7x7mm PQFN44L

## Typical Connection

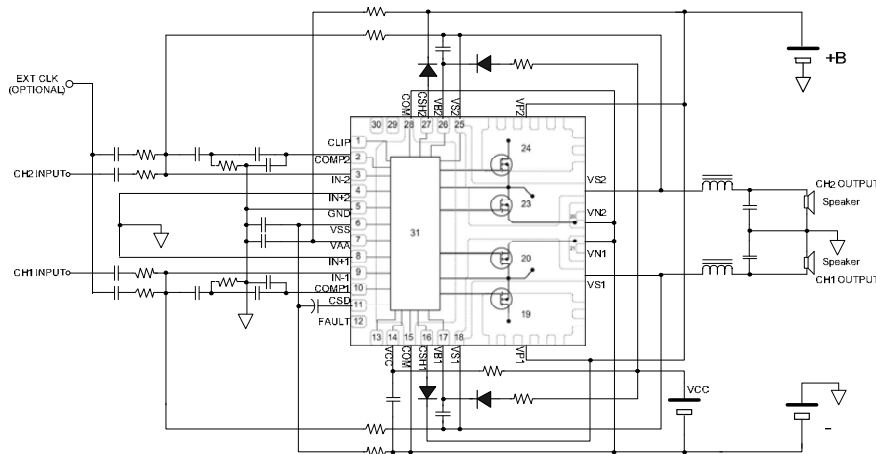

## Functional Block Diagram

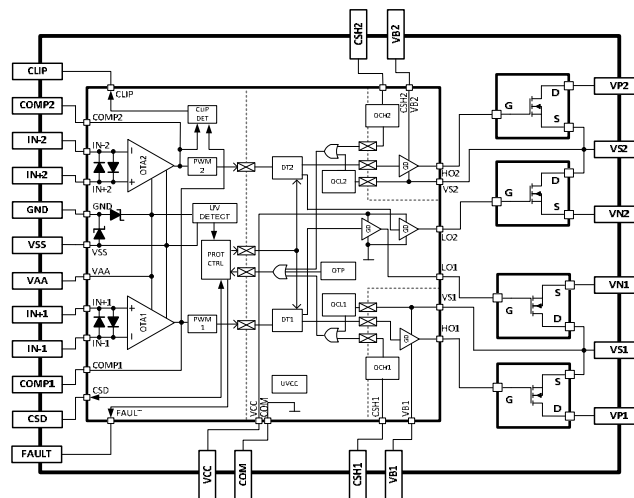

### Lead Assignments (Top View)

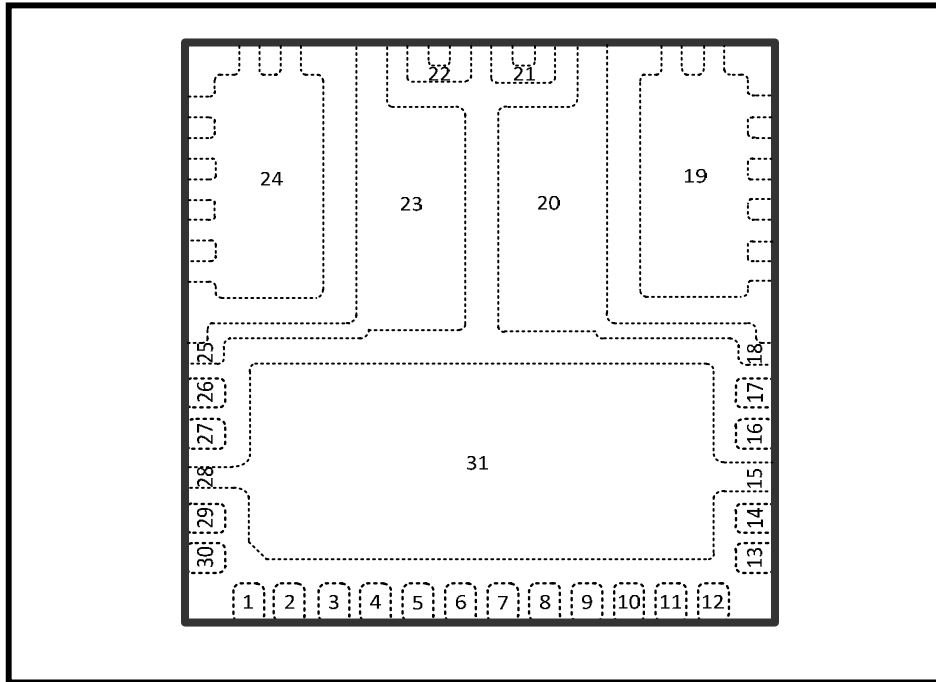

### Lead Definitions

Pin #	Symbol	Description
1	CLIP	Clipping detection output, open drain, referenced to GND
2	COMP2	CH2 PWM comparator input
3	IN-2	CH2 Analog inverting input
4	IN+2	CH2 Analog non-inverting input
5	GND	GND for internal shunt zener diodes to VAA and VSS
6	VSS	Floating input negative supply
7	VAA	Floating input positive supply
8	IN+1	CH1 Analog non-inverting input
9	IN-1	CH1 Analog inverting input
10	COMP1	CH1 PWM comparator input
11	CSD	Shutdown timing capacitor / shutdown input
12	FAULT	Fault reporting output, open drain, referenced to GND
13	NC	
14	VCC	Low side supply
15	COM	Low side supply return, internally connected to pin 31
16	CSH1	CH1 High side over current sensing input, referenced to VS1
17	VB1	CH1 High side floating supply
18	VS1	CH1 PWM output, internally connected to pin 20
19	VP1	CH1 Positive power supply
20	VS1	CH1 PWM output
21	VN1	CH1 Negative power supply, connect to COM externally
22	VN2	CH2 Negative power supply, connect to COM externally
23	VS2	CH2 PWM output, internally connected to pin 25
24	VP2	CH2 Positive power supply
25	VS2	CH2 PWM output
26	VB2	CH2 High side floating supply
27	CSH2	CH2 High side over current sensing input, referenced to VS2
28	COM	Low side supply return, internally connected to pin 31
29	NC	
30	NC	
31	COM	Low side supply return

## DIGITAL PCB ASS'Y

※Parts indicated by "nsp" on this table cannot be supplied.

※The parts listed below are only for maintenance. Therefore they might differ from the parts used in the unit in appearances or dimensions.

NOTE: The symbols in the column Remarks indicate the following destinations.

E3 : U.S.A. &amp; Canada model E2 : Europe model E1C : China model E1 : Asia model JP : Japan model

BK : Black model SP : Premium Silver model

REF No.	Part No.	Part Name	Remarks	Q'ty	New	Ver
<b>SEMICONDUCTORS GROUP</b>						
D101	90M-HD201820R	DIODE, SCHOTTKEY BARRIER		HVDRB160L60TE25	1	
D103-108	943209001080S	DIODE, CHIP, SWITCHING		CVD1SS355T	6	
D111-117	943209001080S	DIODE, CHIP, SWITCHING		CVD1SS355T	7	
D119	943209001080S	DIODE, CHIP, SWITCHING		CVD1SS355T	1	
D201-203	943209001080S	DIODE, CHIP, SWITCHING		CVD1SS355T	3	
D301	943209001080S	DIODE, CHIP, SWITCHING		CVD1SS355T	1	
IC11	943231101810D	I.C, MCU FLASH(32KB,LFQFP-44)		CVIR5F100FCAFP	1	*
IC12	943239011300S	Reset IC (3V, SSOP5)		CVIBD4730G	1	
IC14	00D263124290S	I.C, VOLTAGE REGULATOR(3.3V, SOP-23-5)		CVINJM2831F33	1	
IC21	943236101350D	I.C, DIR/DIT(WITH ADC,LQFP-48P)		CVIPCM9211PTR	1	
IC27	943231101600S	I.C REGULATOR 5.0V LDO,SOT-223		CVILM1117C-5V0	1	
IC31	-	I.C, CPLD (TQFP-100P)		CVI5M80ZT100C5N	1	
IC31	943236101900D	I.C. PLD(HEOSAMPE2/E3)		CVIANAM1918A	1	*
IC32	23681008306S	I.C, CLOCK JITTER		CVICS210010-CZZR	1	
IC33	943239010400S	I.C. REGULATOR(1.8V/TO-252)		CVINJM2845DL118	1	
IC34,35	943239100810D	I.C. AUDIO DAC, REV.F, DENON		CVIPCM5102PWRF	2	*
IC41	943239101090S	I.C, High side switch (TSSOP-B8)		CVIBD82065FVJ-E2	1	
Q101	00MHX300012AY	T.R, 2SC4081, NPN, UMT3, ROHM		CVT2SC4081	1	
Q102	943216500020S	T.R,RT1N141C(10K-10K)		CVTRT1N141C	1	
Q106	943212500300D	T.R, 2SA1576A, PNP, UMT3, ROHM		CVT2SA1576A	1	*
Q107	00MHX300012AY	T.R, 2SC4081, NPN, UMT3, ROHM		CVT2SC4081	1	
Q108	943222500330D	FET, NTR4501N, N-CH, SOT-23, ONSEMI		CVTNT4501NT1G	1	*
Q113-117	943216500020S	T.R,RT1N141C(10K-10K)		CVTRT1N141C	5	
<b>RESISTOR GROUP</b>						
R101	nsp	RES, CHIP(1005/5%/0ohm)		CRJ06J0R0T	1	
R102	nsp	RES, CHIP(1005/5%/33ohm)		CRJ06J330T	1	
R103	nsp	RES, CHIP(1005/5%/4.7Kohm)		CRJ06J472T	1	
R104	nsp	RES, CHIP(1005/5%/47ohm)		CRJ06J470T	1	
R105	nsp	RES, CHIP(1005/5%/0ohm)		CRJ06J0R0T	1	
R106,107	nsp	RES, CHIP(1608/5%/0ohm)		CRJ10DJ0R0T	2	
R109,110	nsp	RES, CHIP(1005/5%/0ohm)		CRJ06J0R0T	2	
R111-118	nsp	RES, CHIP(1005/5%/33ohm)		CRJ06J330T	8	
R119	nsp	RES, CHIP(1005/5%/0ohm)		CRJ06J0R0T	1	
R121-127	nsp	RES, CHIP(1005/5%/33ohm)		CRJ06J330T	7	
R128	nsp	RES, CHIP(1005/5%/1Kohm)		CRJ06J102T	1	
R129-131	nsp	RES, CHIP(1005/5%/33ohm)		CRJ06J330T	3	
R133,134	nsp	RES, CHIP(1005/5%/33ohm)		CRJ06J330T	2	
R137-140	nsp	RES, CHIP(1005/5%/3.3Kohm)		CRJ06J332T	4	
R142	nsp	RES, CHIP(1005/5%/47Kohm)		CRJ06J473T	1	
R143-147	nsp	RES, CHIP(1005/5%/3.3Kohm)		CRJ06J332T	5	
R148-151	nsp	RES, CHIP(1005/5%/4.7Kohm)		CRJ06J472T	4	
R152	nsp	RES, CHIP(1005/5%/3.3Kohm)		CRJ06J332T	1	
R153	nsp	RES, CHIP(1005/5%/4.7Kohm)		CRJ06J472T	1	
R162	nsp	RES, CHIP(1005/5%/0ohm)		CRJ06J0R0T	1	
R164-166	nsp	RES, CHIP(1005/5%/10Kohm)		CRJ06J103T	3	
R167	nsp	RES, CHIP(1005/5%/22ohm)		CRJ06J220T	1	
R168-170	nsp	RES, CHIP(1005/5%/10Kohm)		CRJ06J103T	3	
R171	nsp	RES, CHIP(1608/5%/560Kohm)		CRJ10DJ564T	1	*
R172	nsp	RES, CHIP(1005/5%/10Kohm)		CRJ06J103T	1	
R173	nsp	RES, CHIP(1005/5%/22Kohm)		CRJ06J223T	1	
R174	nsp	RES, CHIP(1005/5%/8.2Kohm)		CRJ06J822T	1	
R175,176	nsp	RES, CHIP(1005/5%/100Kohm)		CRJ06J104T	2	
R177	nsp	RES, CHIP(1005/5%/1Kohm)		CRJ06J102T	1	
R178	nsp	RES, CHIP(1005/5%/100Kohm)		CRJ06J104T	1	
R179	nsp	RES, CHIP(1005/5%/10Kohm)		CRJ06J103T	1	
R180	nsp	RES, CHIP(1005/5%/22Kohm)		CRJ06J223T	1	
R181	nsp	RES, CHIP(1608/5%/15Kohm)		CRJ10DJ153T	1	
R182	nsp	RES, CHIP(1005/5%/10Kohm)		CRJ06J103T	1	
R183	nsp	RES, CHIP(1005/5%/22Kohm)		CRJ06J223T	1	
R185	nsp	RES, CHIP(1005/5%/10Kohm)		CRJ06J103T	1	
R186	nsp	RES, CHIP(1005/5%/22Kohm)		CRJ06J223T	1	
R188	nsp	RES, CHIP(1005/5%/10Kohm)		CRJ06J103T	1	
R189	nsp	RES, CHIP(1005/5%/22Kohm)		CRJ06J223T	1	
R205,206	nsp	RES, CHIP(1005/5%/10Kohm)		CRJ06J103T	2	
R207	nsp	RES, CHIP(1005/5%/4.7Kohm)		CRJ06J472T	1	
R209	nsp	RES, CHIP(1005/5%/10Kohm)		CRJ06J103T	1	
R210	nsp	RES, CHIP(1005/5%/100Kohm)		CRJ06J104T	1	
R211-218	nsp	RES, CHIP(1005/5%/33ohm)		CRJ06J330T	8	
R219,220	nsp	RES, CHIP(1005/5%/0ohm)		CRJ06J0R0T	2	
R222	nsp	RES, CHIP(1005/5%/0ohm)		CRJ06J0R0T	1	
R223	nsp	RES, CHIP(1005/5%/33ohm)		CRJ06J330T	1	
R224	nsp	RES, CHIP(1005/5%/0ohm)		CRJ06J0R0T	1	
R225	nsp	RES, CHIP(1608/5%/1Mohm)		CRJ10DJ105T	1	
R226	nsp	RES, CHIP(1608/5%/100ohm)		CRJ10DJ101T	1	
R227	nsp	RES, CHIP(1608/5%/680ohm)		CRJ10DJ681T	1	
R228,229	nsp	RES, CHIP(1005/5%/10Kohm)		CRJ06J103T	2	
R266,267	nsp	RES, CHIP(1005/5%/1Kohm)		CRJ06J102T	2	
R270,271	nsp	RES, CHIP(1005/5%/100ohm)		CRJ06J101T	2	
R301	nsp	RES, CHIP(1005/5%/0ohm)		CRJ06J0R0T	1	
R304-306	nsp	RES, CHIP(1005/5%/0ohm)		CRJ06J0R0T	3	
R307	nsp	RES, CHIP(1005/5%/100ohm)		CRJ06J101T	1	
R308,309	nsp	RES, CHIP(1005/5%/10Kohm)		CRJ06J103T	2	
R310	nsp	RES, CHIP(1005/5%/1Kohm)		CRJ06J102T	1	
R311-315	nsp	RES, CHIP(1005/5%/100ohm)		CRJ06J101T	5	
R317-324	nsp	RES, CHIP(1005/5%/100ohm)		CRJ06J101T	8	
R332-335	nsp	RES, CHIP(1005/5%/100ohm)		CRJ06J101T	4	
R336-338	nsp	RES, CHIP(1005/5%/0ohm)		CRJ06J0R0T	3	
R339-342	nsp	RES, CHIP(1005/5%/100ohm)		CRJ06J101T	4	
R344,345	nsp	RES, CHIP(1005/5%/100ohm)		CRJ06J101T	2	
R346-348	nsp	RES, CHIP(1005/5%/10Kohm)		CRJ06J103T	3	
R349,350	nsp	RES, CHIP(1005/5%/0ohm)		CRJ06J0R0T	2	
R351	nsp	RES, CHIP(1005/5%/10Kohm)		CRJ06J103T	1	
R353	nsp	RES, CHIP(1005/5%/0ohm)		CRJ06J0R0T	1	
R354-357	nsp	RES, CHIP(1005/5%/33ohm)		CRJ06J330T	4	

REF No.	Part No.	Part Name	Remarks	Q'ty	New	Ver
R358-361	nsp	RES, CHIP(1005/5%/0ohm)	CRJ061J0R0T	4		
R362	nsp	RES, CHIP(1005/5%/10Kohm)	CRJ061J103T	1		
R364	nsp	RES, CHIP(1005/5%/0ohm)	CRJ061J0R0T	1		
R365-368	nsp	RES, CHIP(1005/5%/33ohm)	CRJ061J330T	4		
R369,370	nsp	RES, CHIP(1005/5%/0ohm)	CRJ061J0R0T	2		
R371	nsp	RES, CHIP(1005/5%/33ohm)	CRJ061J330T	1		
R383-386	nsp	RES, CHIP(1005/5%/470ohm)	CRJ061J471T	4		
R391,392	nsp	RES, CHIP(1005/5%/0ohm)	CRJ061J0R0T	2		
R395	nsp	RES, CHIP(1005/5%/0ohm)	CRJ061J0R0T	1		
R406	nsp	RES, CHIP(1005/5%/33ohm)	CRJ061J330T	1		
R410-412	nsp	RES, CHIP(1005/5%/33ohm)	CRJ061J330T	3		
R413,414	nsp	RES, CHIP(1005/5%/0ohm)	CRJ061J0R0T	2		
R416	nsp	RES, CHIP(1005/5%/10Kohm)	CRJ061J103T	1		
R417	nsp	RES, CHIP(1005/5%/2.7Kohm)	CRJ061J272T	1		
R418	nsp	RES, CHIP(1005/5%/10Kohm)	CRJ061J103T	1		
R419	nsp	RES, CHIP(1005/5%/1.8Kohm)	CRJ061J182T	1		
R420,421	nsp	RES, CHIP(1005/5%/0ohm)	CRJ061J0R0T	2		
R423	nsp	RES, CHIP(1005/5%/33ohm)	CRJ061J330T	1		
R424-427	nsp	RES, CHIP(1005/5%/0ohm)	CRJ061J0R0T	4		
R432	nsp	RES, CHIP(1005/5%/10ohm)	CRJ061J100T	1		
R440	nsp	RES, CHIP(1005/5%/10Kohm)	CRJ061J103T	1		
R443	nsp	RES, CHIP(1005/5%/10Kohm)	CRJ061J103T	1		
R448	nsp	RES, CHIP(1005/5%/33ohm)	CRJ061J330T	1		
R450	nsp	RES, CHIP(1005/5%/33ohm)	CRJ061J330T	1		
R452-469	nsp	RES, CHIP(1005/5%/33ohm)	CRJ061J330T	18		
R475-478	nsp	RES, CHIP(1005/5%/0ohm)	CRJ061J0R0T	4		
R479	nsp	RES, CHIP(1005/5%/33ohm)	CRJ061J330T	1		
R803	nsp	RES, CHIP(1005/5%/33ohm)	CRJ061J330T	1		
R804	nsp	RES, CHIP(1005/5%/10Kohm)	CRJ061J103T	1		
R805,806	nsp	RES, CHIP(1005/5%/1Kohm)	CRJ061J102T	2		
R807	nsp	RES, CHIP(1005/5%/0ohm)	CRJ061J0R0T	1		
R808	nsp	RES, CHIP(1608/5%/0ohm)	CRJ10DJ0R0T	1		
R809	nsp	RES, CHIP(1005/5%/33ohm)	CRJ061J330T	1		
R810	nsp	RES, CHIP(1005/5%/3.3Kohm)	CRJ061J332T	1		
<b>CAPACITORS GROUP</b>						
C101	nsp	CAP,ALUMINUM ELECTROLYTIC CAPACITORS(16V/100uF)	CCEC1CMVG101T	1		
C102	nsp	CAP, CHIP(1608, 10V/0.33uF, X7R, X7S)_SAMSUNG	CCUS1A334KCS	1		
C103	nsp	CAP, CHIP(1608, 6.3V/2.2uF, X7R)_SAMSUNG	CCUS0J225KCS	1		
C104	nsp	CAP,ALUMINUM ELECTROLYTIC (6.3V/220uF)	CCEC0JMVG221T	1		
C105	nsp	CAP,CHIP(1608, 10V/1uF, X7R, X7S)_SAMSUNG	CCUS1A105KCS	1		
C106	nsp	CAP,CHIP(1005, 16V/0.1uF, X7R)_SAMSUNG	CCUI1C104KCS	1		
C107,108	nsp	CAP,CHIP(1608, 50V/18pF, C0G)_SAMSUNG	CCUS1H180JAS	2		
C109,110	nsp	RES, CHIP(1608/5%/0ohm)	CRJ10DJ0R0T	2		
C111	nsp	CAP,CHIP(1608, 10V/1uF, X7R, X7S)_SAMSUNG	CCUS1A105KCS	1		
C112	nsp	CAP,CHIP(2012, 6.3V/10uF, X5R)_SAMSUNG	CCUC0J106KCS	1		
C113,114	nsp	CAP,CHIP(1005, 16V/0.1uF, X7R)_SAMSUNG	CCUI1C104KCS	2		
C115-119	nsp	CAP,CHIP(1005, 50V/0.01uF, X7R)_SAMSUNG	CCUI1H103KCS	5		
C120	nsp	CAP,CHIP(1608, 50V/100pF, C0G)_SAMSUNG	CCUS1H101JAS	1		
C121	nsp	CAP,CHIP(1005, 16V/0.1uF, X7R)_SAMSUNG	CCUI1C104KCS	1		
C129-131	nsp	CAP,CHIP(1005, 16V/0.1uF, X7R)_SAMSUNG	CCUI1C104KCS	3		
C133,134	nsp	CAP,CHIP(1005, 16V/0.1uF, X7R)_SAMSUNG	CCUI1C104KCS	2		
C135	nsp	CAP,CHIP(1608, 50V/0.1uF, X7R)_SAMSUNG	CCUS1H104KCS	1		
C137	nsp	CAP, SMD ELECT(16V/47uF)	CCEC1CMVG470T	1	*	
C201	nsp	CAP,CHIP(2012, 10V/0.1uF, MURATA GRM21)	CCUMUC1A104JAM	1	*	
C202	nsp	CAP, SMD ELECT(16V/22uF)	CCEC1CMVG220T	1	*	
C203-205	nsp	CAP,CHIP(1005, 16V/0.1uF, X7R)_SAMSUNG	CCUI1C104KCS	3		
C206	nsp	CAP,ALUMINUM ELECTROLYTIC (16V/10uF)	CCEC1CMVG100T	1		
C207	nsp	CAP,CHIP(1005, 16V/0.1uF, X7R)_SAMSUNG	CCUI1C104KCS	1		
C208,209	nsp	CAP,CHIP(1608, 50V/18pF, C0G)_SAMSUNG	CCUS1H180JAS	2		
C210	nsp	CAP,ALUMINUM ELECTROLYTIC (16V/10uF)	CCEC1CMVG100T	1		
C211	nsp	CAP,CHIP(1005, 16V/0.1uF, X7R)_SAMSUNG	CCUI1C104KCS	1		
C212	nsp	CAP,CHIP(3216, 50V/0.068uF, MURATA GRM31)	CCUMUP1H683JAM	1		
C213	nsp	CAP,CHIP(2012, 50V/4700pF, MURATA GRM21)	CCUMUC1H472JAM	1		
C214	nsp	CAP,CHIP(1005, 16V/0.1uF, X7R)_SAMSUNG	CCUI1C104KCS	1		
C215	nsp	CAP,ALUMINUM ELECTROLYTIC (16V/10uF)	CCEC1CMVG100T	1		
C216	nsp	CAP,CHIP(1005, 16V/0.1uF, X7R)_SAMSUNG	CCUI1C104KCS	1		
C217	nsp	CAP,ALUMINUM ELECTROLYTIC (16V/10uF)	CCEC1CMVG100T	1		
C218	nsp	CAP,ALUMINUM ELECTROLYTIC CAPACITORS(16V/100uF)	CCEC1CMVG101T	1		
C219,220	nsp	CAP,CHIP(1005, 16V/0.1uF, X7R)_SAMSUNG	CCUI1C104KCS	2		
C221	nsp	CAP,ALUMINUM ELECTROLYTIC CAPACITORS(16V/100uF)	CCEC1CMVG101T	1		
C239-241	nsp	CAP,CHIP(1005, 16V/0.1uF, X7R)_SAMSUNG	CCUI1C104KCS	3		
C301	nsp	CAP,ALUMINUM ELECTROLYTIC CAPACITORS(16V/100uF)	CCEC1CMVG101T	1		
C302-309	nsp	CAP,CHIP(1005, 16V/0.1uF, X7R)_SAMSUNG	CCUI1C104KCS	8		
C310	nsp	CAP,CHIP(1005, 50V/1000pF, X7R)_SAMSUNG	CCUI1H102KCS	1		
C311	nsp	CAP,CHIP(1005, 16V/0.1uF, X7R)_SAMSUNG	CCUI1C104KCS	1		
C312	nsp	CAP,CHIP(1005, 50V/1000pF, X7R)_SAMSUNG	CCUI1H102KCS	1		
C313	nsp	CAP,CHIP(1005, 16V/0.1uF, X7R)_SAMSUNG	CCUI1C104KCS	1		
C314	nsp	CAP,CHIP(1005, 50V/1000pF, X7R)_SAMSUNG	CCUI1H102KCS	1		
C315	nsp	CAP,CHIP(1005, 16V/0.1uF, X7R)_SAMSUNG	CCUI1C104KCS	1		
C316	nsp	CAP,CHIP(1005, 50V/1000pF, X7R)_SAMSUNG	CCUI1H102KCS	1		
C317	nsp	CAP,CHIP(1005, 16V/0.1uF, X7R)_SAMSUNG	CCUI1C104KCS	1		
C318	nsp	CAP,CHIP(1005, 50V/1000pF, X7R)_SAMSUNG	CCUI1H102KCS	1		
C319	nsp	CAP,CHIP(1005, 16V/0.1uF, X7R)_SAMSUNG	CCUI1C104KCS	1		
C320	nsp	CAP,CHIP(1005, 50V/1000pF, X7R)_SAMSUNG	CCUI1H102KCS	1		
C321	943134503080D	CAP, SMD ELECT (6.3V/100uF), ELNA RV2	CCEC0JRV2E101T	1	*	
C322	nsp	CAP,CHIP(1005, 16V/0.1uF, X7R)_SAMSUNG	CCUI1C104KCS	1		
C323	943134503080D	CAP, SMD ELECT (6.3V/100uF), ELNA RV2	CCEC0JRV2E101T	1	*	
C324	nsp	CAP,CHIP(1005, 16V/0.1uF, X7R)_SAMSUNG	CCUI1C104KCS	1		
C327,328	nsp	CAP,CHIP(1005, 16V/0.1uF, X7R)_SAMSUNG	CCUI1C104KCS	2		
C329,330	nsp	CAP,CHIP(1608, 6.3V/2.2uF, X7R)_SAMSUNG	CCUS0J225KCS	2		
C331	943134503090D	CAP, SMD ELECT (16V/47uF), ELNA RV2	CCEC1CRV2E470T	1	*	
C332	nsp	CAP,CHIP(1005, 16V/0.1uF, X7R)_SAMSUNG	CCUI1C104KCS	1		
C333	nsp	CAP,CHIP(1005, 50V/1000pF, X7R)_SAMSUNG	CCUI1H102KCS	1		
C334,335	nsp	CAP,CHIP(1005, 16V/0.1uF, X7R)_SAMSUNG	CCUI1C104KCS	2		
C336	943134503090D	CAP, SMD ELECT (16V/47uF), ELNA RV2	CCEC1CRV2E470T	1	*	
C337	nsp	CAP,CHIP(1005, 16V/0.1uF, X7R)_SAMSUNG	CCUI1C104KCS	1		
C338,339	nsp	CAP,CHIP(1608, 6.3V/2.2uF, X7R)_SAMSUNG	CCUS0J225KCS	2		
C340	943134503090D	CAP, SMD ELECT (16V/47uF), ELNA RV2	CCEC1CRV2E470T	1	*	
C341	nsp	CAP,CHIP(1005, 16V/0.1uF, X7R)_SAMSUNG	CCUI1C104KCS	1		
C342	nsp	CAP,CHIP(1005, 50V/1000pF, X7R)_SAMSUNG	CCUI1H102KCS	1		
C343	943134503090D	CAP, SMD ELECT (16V/47uF), ELNA RV2	CCEC1CRV2E470T	1	*	
C344-346	nsp	CAP,CHIP(1005, 16V/0.1uF, X7R)_SAMSUNG	CCUI1C104KCS	3		

REF No.	Part No.	Part Name	Remarks		Q'ty	New	Ver
C347	nsp	CAP, SMD ELECT(16V/47uF)		CCEC1CMVG470T	1	*	
C348	nsp	CAP, CHIP(1005, 50V/0.01uF, X7R) SAMSUNG		CCUI1H103KCS	1		
C367	nsp	CAP, CHIP(1608, 6.3V/4.7uF, X5R) SAMSUNG		CCUS0J475KCS	1		
C372	nsp	CAP, CHIP(1005, 50V/100pF, C0G) SAMSUNG		CCUI1H101JAS	1		
C401-406	nsp	CAP, CHIP(1005, 50V/0.01uF, X7R) SAMSUNG		CCUI1H103KCS	6		
C411	nsp	CAP, CHIP(1005, 25V/0.022uF, X7R) SAMSUNG		CCUI1E223KCS	1		
C423	nsp	CAP, CHIP(1005, 16V/0.1uF, X7R) SAMSUNG		CCUI1C104KCS	1		
C426,427	nsp	CAP, CHIP(1608, 16V/1uF, X7R) SAMSUNG		CCUS1C105KCS	2		
C430-433	nsp	CAP, CHIP(1608, 50V/0.1uF, X7R) SAMSUNG		CCUS1H104KCS	4		
C434	nsp	CAP, CHIP(1005, 16V/0.1uF, X7R) SAMSUNG		CCUI1C104KCS	1		
<b>OTHER PARTS GROUP</b>							
CN11	nsp	WAFER, FFC, SMD(07P-1mm, STRAIGHT)		CJP07GA193ZY	1		
CN13	nsp	WAFER, 2mm, SMD, Vertical, 07p		CJP07GA208ZY	1		
CN14	nsp	PIN SOCKET (09P,1.25mm,ANGLE,B-TO-B)		CJP09HJ282Z	1		
CN21	nsp	PIN SOCKET (27P,1.25mm,ANGLE,B-TO-B)		CJP27HJ282Z	1		
CN31	nsp	WAFER, FFC, SMD(07P-1mm, STRAIGHT)		CJP07GA193ZY	1		
CN41,42	nsp	FEMALE HEADER(40P,PITCH=2mm,H:4.3mm)DUAL ROW,SMT		CJP40GA213ZB	2	*	
CN43	nsp	WAFER , SMD (2MM PITCH)		CJP05GA208ZY	1		
BK11,12	nsp	BRACKET , PCB		CMD2A569-V1	2	*	
BN54	nsp	WAFER, FFC, SMD(11P-1mm, STRAIGHT)		CJP11GA193ZY	1		
JK31	943643102630M	MODULE , OPTICAL(RX 25MHz)		CJSJSR2124-00-BB	1		
JK42	943643102430S	JACK , RJ-45 W/TRANSFORMER		CJJ9L029Z	1		
JK43	943643102570M	JACK, USB VERTICAL, BLACK		CJJ9X013ZL	1		
L101	nsp	FERRITE CHIP BEAD(1608/60R, CB03YTYH600)		CLZ9R005V	1		
L213	nsp	BEAD , FERRITE (FCM2012KF-121T08 , 120 OHM)		CLZ9R010Z	1		
L301,302	nsp	FERRITE CHIP BEAD(2012/220R, CB05YTYH221)		CLZ9R018V	2		
L303,304	nsp	BEAD , FERRITE (FCM2012KF-121T08 , 120 OHM)		CLZ9R010Z	2		
L403,404	nsp	COIL, CHOKE CHIP(2012/90R)		CLZ9Z128Z	2		
L408	nsp	RES, CHIP(2012/5%/0ohm)		CRJ18AJ0R0T	1		
S101	943662101000D	SW, TACT, VERTICAL (BLACK, 5.8mm)		CST1A039ZT	1	*	
ST11	nsp	WIRE ASS'Y(1P, 80MM,BLK,#22)		CWE5202080A	1		
X101	nsp	X-TAL, 32.768KHz, TuningFork, 12.5pF, 10ppm		COX00032K125110	1	*	
X201	943141100620S	X-TAL, SMD 3.2X2.5, 24.576MHz, 12PF		COX245761120ST	1		
★	nsp	WASHER , GROUND		CNW1A035	3		



MAIN PCB ASS'Y

※Parts indicated by "nsp" on this table cannot be supplied.

※The parts listed below are only for maintenance. Therefore they might differ from the parts used in the unit in appearances or dimensions.

NOTE: The symbols in the column Remarks indicate the following destinations.

E3 : U.S.A. & Canada model E2 : Europe model E1C : China model E1 : Asia model JP : Japan model

BK : Black model SP : Premium Silver model

REF No.	Part No.	Part Name	Remarks	Q'ty	New	Ver
<b>SEMICONDUCTORS GROUP</b>						
D513.514	943203003150S	DIODE , RECTIFIER, RADIAL		CVD1N4007SRT	2	
D515	943209001080S	DIODE , CHIP , SWITCHING		CVD1SS355T	1	
D596	943209001080S	DIODE , CHIP , SWITCHING		CVD1SS355T	1	
D597	943251100080S	ESD SUPPRESSOR (ASQS 12U 02 0R2, 0.2pF/12V 1005)		CLZ9Z120Z	1	
D598	943209001080S	DIODE , CHIP , SWITCHING		CVD1SS355T	1	
D599	943251100080S	ESD SUPPRESSOR (ASQS 12U 02 0R2, 0.2pF/12V 1005)		CLZ9Z120Z	1	
D701-713	943209001080S	DIODE , CHIP , SWITCHING		CVD1SS355T	13	
D811-813	943251100080S	ESD SUPPRESSOR (ASQS 12U 02 0R2, 0.2pF/12V 1005)		CLZ9Z120Z	3	
D814	943263101020D	L.E.D BLUE CHIP 2012		CVD1SA0805B22C0	1	*
D821.822	943263101030D	L.E.D 3 COLOR CHIP 0505 (RED, BLUE, GREEN)		CVD1SC5050BRG0	2	*
D901	nsp	DIODE , FAST SWITCHING(0.5W, SOD-123)		CVD1N4448W	1	*
D902	nsp	DIODE , ZENER(27V/0.5W, SOD-123)		CVDMM1Z27H	1	*
D903	nsp	DIODE , ULTRA FAST RECTIFIER		CVDUS1M	1	*
D904	943202500870D	DIODE , ZENER(24V/0.5W, SOD-123)		CVDUDZS24BSRH	1	*
D905.906	nsp	DIODE , ULTRA FAST RECTIFIER		CVDUS1M	2	*
D907	nsp	DIODE , RECTIFIER(FFM107-M, SOD-123FL)		CVDFFM107M	1	*
D908	943202500880D	DIODE , ZENER(24V/0.5W, SOD-123)		CVDMM1Z24H	1	*
D909	nsp	DIODE , FAST SWITCHING(0.5W, SOD-123)		CVD1N4448W	1	*
D911	nsp	DIODE , ULTRA FAST RECTIFIER		CVDUS1M	1	*
D912	943202008160S	DIODE , ZENER , 1/2W, 12V		CVDZJ12BT	1	*
D913	nsp	DIODE , RECTIFIER(DSR1M, SOD-123FL)		CVDDSR1M	1	*
D914	943202500890D	DIODE , ZENER(13V/0.5W, SOD-123)		CVDMM1Z13H	1	*
D916	943202500880D	DIODE , ZENER(24V/0.5W, SOD-123)		CVDMM1Z24H	1	*
D920	nsp	DIODE , RECTIFIER(DSR1M, SOD-123FL)		CVDDSR1M	1	*
D926-929	nsp	DIODE , FAST SWITCHING(0.5W, SOD-123)		CVD1N4448W	4	*
D932	nsp	DIODE , RECTIFIER(DSR1M, SOD-123FL)		CVDDSR1M	1	*
D933.934	nsp	DIODE , FAST RECTIFIER( 400V, 2A)		CVDUS2G	2	*
D937	nsp	DIODE , FAST RECTIFIER( 400V, 2A)		CVDUS2G	1	*
D938	nsp	DIODE , FAST SWITCHING(0.5W, SOD-123)		CVD1N4448W	1	*
D942.943	943204500390D	DIODE , SCHOTTKY, 60V, 3A, C351B-1		CVD30GQA06H	2	*
D950	943202500900D	DIODE , ZENER(15V/0.5W, SOD-123)		CVDMM1Z15H	1	*
D952.953	nsp	DIODE HEAT SINK ASS'Y (CMY5A222-V2)		CVDFCU20A40BCA	2	*
DB91	nsp	DIODE , BRIDGE (600V/10A,RS-10M)		CVDRS1005M	1	*
IC21.22	943239101070S	I.C. ,DC-DC CONVERTER (3A, QFN T&R-24P)		CVIEN5339QI	2	*
IC53	943235100710D	I.C. , VOLUME 7.1CH(SQFP-T80C)		CVIBD3473KS2	1	*
IC54.55	00D2631289900	I.C. ,OPAMP(DUAL/LOW NOISE) Copper		CVIAZ4580MTR-E1-2	2	*
IC56	943233102040D	I.C. , MULTIPLEXER(S-PDSO-G10)		CVITSA22362DGS	1	*
IC71.72	943239101560D	IC, Integrated ClassD Audio Amplifier		CVIIR4322MTRPBF	2	*
IC73	943231101940D	I.C. , REGULATOR (12V/300mA, SOT-89-5, 5PIN)		CVINJM2830U1-12	1	*
IC75	00D2631289900	I.C. ,OPAMP(DUAL/LOW NOISE) Copper		CVIAZ4580MTR-E1-1	1	*
IC91	943231101950D	I.C. , SMPS CONTROLLER(PG-DIP-8)		CVIICE3BR0665J	1	*
IC93	943239101570D	I.C. , PWM CONTROLLER(PG-DSO-8)		CVIICE2QS02G	1	*
IC94	943231101850S	I.C. , SHUNT REGULATOR(SOT-23F)		CVIKA431SAMF2	1	*
IC95	00D2630801004	I.C. , REGULATOR		HVINJM7812FA	1	*
IC96	943224501000S	FET, FDS6675BZ, P-CH, SO-8, FAIRCHILD		CVTFDS6675BZ	1	*
IC97	943231101850S	I.C. , SHUNT REGULATOR(SOT-23F)		CVIKA431SAMF2	1	*
IC98	00MHC3990809F	I.C REGULATOR		HVINJM7908FA	1	*
IC99	00D2630810008	I.C REGULATOR		HVINJM7808FA	1	*
Q202	943216500020S	T.R,RT1N141C(10K-10K)		CVTRT1N141C	1	*
Q511.512	00D9430072502	T.R , CHIP , SOT-23		HVTKTC2875B	2	*
Q513	943213500160S	T.R,RT1N237C(2.2K-47K)		CVTRT1N237C	1	*
Q514	943212500300D	T.R. ,2SA1576A, PNP, UMT3, ROHM		CVT2SA1576A	1	*
Q532.533	943213500160S	T.R,RT1N237C(2.2K-47K)		CVTRT1N237C	2	*
Q534	943212500300D	T.R. ,2SA1576A, PNP, UMT3, ROHM		CVT2SA1576A	1	*
Q535	943213500160S	T.R,RT1N237C(2.2K-47K)		CVTRT1N237C	1	*
Q711	943215500140D	T.R,RT1P144C(10K-47K)		CVTRT1P144C	1	*
Q712.713	00D2730464901	T.R , CHIP , SOT-23		HVTKTC3875SYRTH	2	*
Q721	00D9430058908	T.R , CHIP , SOT-23		HVTKTA1504SYRTH	1	*
Q722	943216500020S	T.R,RT1N141C(10K-10K)		CVTRT1N141C	1	*
Q732.733	943214500020S	T.R.2SC3052		CVT2SC3052	2	*
Q734	963212500030S	T.R. ISA1530AC1		CVTISA1530AC1	1	*
Q811	943216500020S	T.R,RT1N141C(10K-10K)		CVTRT1N141C	1	*
Q821-823	943213500160S	T.R,RT1N237C(2.2K-47K)		CVTRT1N237C	3	*
Q901	nsp	FET HEAT SINK ASS'Y (CMY1A418)		CVTSPW17N80C3B	1	*
Q901	943222500340D	F.E.T , SPW17N80C3 (800V/17A, PG-TO247-3)		CVTSPW17N80C3	1	*
Q902	90M-HT600060R	T.R		HVTKSA708YT	1	*
Q922	943216500020S	T.R,RT1N141C(10K-10K)		CVTRT1N141C	1	*
Q923	90M-HX800060R	T.R , CHIP(SOT-89)		HVTKC4379Y	1	*
Q924	nsp	T.R. ,KTA1298(PNP, SOT-23)		CVTKTA1298	1	*
Q925	nsp	T.R. ,2SA2167, PNP, SOT-89, HFE E, ISAHAYA		CVT2SA2167ES	1	*
Q926.927	943216500020S	T.R,RT1N141C(10K-10K)		CVTRT1N141C	2	*
Q930	943216500020S	T.R,RT1N141C(10K-10K)		CVTRT1N141C	1	*
Q931	00D2730464901	T.R , CHIP , SOT-23		HVTKTC3875SYRTH	1	*
Q932	nsp	T.R. ,2SA2167, PNP, SOT-89, HFE E, ISAHAYA		CVT2SA2167ES	1	*
Q933	943216500020S	T.R,RT1N141C(10K-10K)		CVTRT1N141C	1	*
<b>RESISTOR GROUP</b>						
R201	nsp	RES, CHIP(1608/5%/10ohm)		CRJ10DJ100T	1	*
R202	nsp	RES, CHIP(1608/5%/4.7Kohm)		CRJ10DJ472T	1	*
R203	nsp	RES, CHIP(1608/5%/100Kohm)		CRJ10DJ104T	1	*
R204	nsp	RES, CHIP(1608/1%/348Kohm)		CRJ10DF3483T	1	*
R205	nsp	RES, CHIP(1608/1%/76.8Kohm)		CRJ10DF7682T	1	*
R206	nsp	RES, CHIP(1608/5%/0ohm)		CRJ10DJ0R0T	1	*
R209	nsp	RES, CHIP(1608/5%/100Kohm)		CRJ10DJ104T	1	*
R210	nsp	RES, CHIP(1608/1%/348Kohm)		CRJ10DF3483T	1	*
R211	nsp	RES, CHIP(1608/1%/76.8Kohm)		CRJ10DF7682T	1	*
R212	nsp	RES, CHIP(1608/5%/0ohm)		CRJ10DJ0R0T	1	*
R214	nsp	RES, CHIP(1608/5%/10Kohm)		CRJ10DJ103T	1	*
R215	nsp	RES, CHIP(1608/5%/3.3Kohm)		CRJ10DJ332T	1	*
R501	nsp	RES, CARBON(1/5W,470ohm,J)		CRD20TJ471T	1	*
R502	nsp	RES, CHIP(1608/5%/100Kohm)		CRJ10DJ104T	1	*
R505	nsp	RES, CHIP(1608/5%/47Kohm)		CRJ10DJ473T	1	*
R506	nsp	RES, CARBON(1/5W,470ohm,J)		CRD20TJ471T	1	*
R507	nsp	RES, CHIP(1608/5%/100Kohm)		CRJ10DJ104T	1	*
R510	nsp	RES, CHIP(1608/5%/27Kohm)		CRJ10DJ273T	1	*

REF No.	Part No.	Part Name	Remarks	Q'ty	New	Ver
R512	nsp	RES, CHIP(1608/5%/1Kohm)		CRJ10DJ102T	1	*
R515	nsp	RES, CHIP(1608/5%/27Kohm)		CRJ10DJ273T	1	*
R516	nsp	RES, CHIP(1608/5%/6.8Kohm)		CRJ10DJ682T	1	*
R517	nsp	RES, CHIP(1608/5%/470ohm)		CRJ10DJ471T	1	*
R518	nsp	RES, CHIP(1608/5%/15Kohm)		CRJ10DJ153T	1	*
R519	nsp	RES, CHIP(1608/5%/4.7Kohm)		CRJ10DJ472T	1	*
R520	nsp	RES, CHIP(1608/5%/10Kohm)		CRJ10DJ103T	1	*
R523,524	nsp	RES, CHIP(1608/5%/100Kohm)		CRJ10DJ104T	2	*
R525	nsp	RES, CHIP(1608/5%/220ohm)		CRJ10DJ221T	1	*
R526	nsp	RES, CHIP(1608/5%/100Kohm)		CRJ10DJ104T	1	*
R527	nsp	RES, CHIP(1608/5%/47Kohm)		CRJ10DJ473T	1	*
R528	nsp	RES, CHIP(1608/5%/470ohm)		CRJ10DJ471T	1	*
R529	nsp	RES, CHIP(1608/5%/3.3Kohm)		CRJ10DJ332T	1	*
R530	nsp	RES, CHIP(1608/5%/470ohm)		CRJ10DJ471T	1	*
R531	nsp	RES, CHIP(1608/5%/3.3Kohm)		CRJ10DJ332T	1	*
R533,534	nsp	RES, CHIP(1608/5%/33ohm)		CRJ10DJ330T	2	*
R535	nsp	RES, CHIP(1608/5%/0ohm)		CRJ10DJ0R0T	1	*
R536	nsp	RES, CHIP(1608/5%/220ohm)		CRJ10DJ221T	1	*
R537	nsp	RES, CHIP(1608/5%/4.7Kohm)		CRJ10DJ472T	1	*
R538	nsp	RES, CHIP(1608/5%/33Kohm)		CRJ10DJ333T	1	*
R539	nsp	RES, CHIP(1608/5%/150Kohm)		CRJ10DJ154T	1	*
R540	nsp	RES, CHIP(1608/5%/3.3Kohm)		CRJ10DJ332T	1	*
R541-543	nsp	RES, CHIP(1608/5%/0ohm)		CRJ10DJ0R0T	3	*
R545	nsp	RES, CHIP(1608/5%/0ohm)		CRJ10DJ0R0T	1	*
R546	nsp	RES, CHIP(1608/5%/470ohm)		CRJ10DJ471T	1	*
R547	nsp	RES, CHIP(1608/5%/4.7Kohm)		CRJ10DJ472T	1	*
R548	nsp	RES, CHIP(1608/5%/0ohm)		CRJ10DJ0R0T	1	*
R551	nsp	RES, CARBON(1/5W,470ohm,J)		CRD20TJ471T	1	*
R552	nsp	RES, CHIP(1608/5%/100Kohm)		CRJ10DJ104T	1	*
R556	nsp	RES, CARBON(1/5W,470ohm,J)		CRD20TJ471T	1	*
R557	nsp	RES, CHIP(1608/5%/100Kohm)		CRJ10DJ104T	1	*
R560	nsp	RES, CHIP(1608/5%/27Kohm)		CRJ10DJ273T	1	*
R561	nsp	RES, CHIP(1608/5%/18Kohm)		CRJ10DJ183T	1	*
R562	nsp	RES, CHIP(1608/5%/1Kohm)		CRJ10DJ102T	1	*
R563	nsp	RES, CHIP(1608/5%/0ohm)		CRJ10DJ0R0T	1	*
R565	nsp	RES, CHIP(1608/5%/27Kohm)		CRJ10DJ273T	1	*
R568	nsp	RES, CHIP(1608/5%/12Kohm)		CRJ10DJ123T	1	*
R569	nsp	RES, CHIP(1608/5%/4.7Kohm)		CRJ10DJ472T	1	*
R572	nsp	RES, CHIP(1608/5%/0ohm)		CRJ10DJ0R0T	1	*
R576	nsp	RES, CHIP(1608/5%/100Kohm)		CRJ10DJ104T	1	*
R578-580	nsp	RES, CHIP(1608/5%/47Kohm)		CRJ10DJ473T	3	*
R581	nsp	RES, CHIP(1608/5%/620ohm)		CRJ10DJ621T	1	*
R582	nsp	RES, CHIP(1608/5%/1.1Kohm)		CRJ10DJ112T	1	*
R583	nsp	RES, CHIP(1608/5%/10Kohm)		CRJ10DJ103T	1	*
R585	nsp	RES, CHIP(1608/5%/0ohm)		CRJ10DJ0R0T	1	*
R590	nsp	RES, CHIP(1608/5%/2.4Kohm)		CRJ10DJ242T	1	*
R595	nsp	RES, CHIP(1608/5%/33Kohm)		CRJ10DJ333T	1	*
R596	nsp	RES, CHIP(1608/5%/47Kohm)		CRJ10DJ473T	1	*
R701	nsp	RES, CHIP(2012/5%/3.3Kohm)		CRJ18AJ332T	1	*
R703	nsp	RES, CHIP(2012/5%/3.3Kohm)		CRJ18AJ332T	1	*
R704	nsp	RES, CHIP(3216/1%/47Kohm)		CRJ14CF4702T	1	*
R705	nsp	RES, CHIP(2012/5%/0ohm)		CRJ18AJ0R0T	1	*
R706	nsp	RES, CHIP(3216/1%/47Kohm)		CRJ14CF4702T	1	*
R707,708	nsp	RES, CHIP(1608/5%/3.3Kohm)		CRJ10DJ332T	2	*
R709	nsp	RES, CHIP(1608/5%/0ohm)		CRJ10DJ0R0T	1	*
R710,711	nsp	RES, CHIP(1608/5%/180ohm)		CRJ10DJ181T	2	*
R712	nsp	RES, CHIP(1608/5%/100ohm)		CRJ10DJ101T	1	*
R713,714	nsp	RES, CHIP(1608/5%/4.7ohm)		CRJ10DJ4R7T	2	*
R715	nsp	RES, CHIP(1608/5%/0ohm)		CRJ10DJ0R0T	1	*
R716	nsp	RES, CHIP(1608/5%/100Kohm)		CRJ10DJ104T	1	*
R717-719	nsp	RES, CHIP(1608/5%/4.7ohm)		CRJ10DJ4R7T	3	*
R720,721	nsp	RES, CHIP(2012/5%/10Kohm)		CRJ18AJ103T	2	*
R722,723	nsp	RES, CHIP(2012/5%/1ohm)		CRJ18AJ1R0T	2	*
R724,725	nsp	RES, CHIP(1608/5%/47Kohm)		CRJ10DJ473T	2	*
R729	nsp	RES, CHIP(1608/5%/100Kohm)		CRJ10DJ104T	1	*
R730	nsp	RES, CHIP(2012/5%/3.3Kohm)		CRJ18AJ332T	1	*
R732	nsp	RES, CHIP(2012/5%/3.3Kohm)		CRJ18AJ332T	1	*
R733	nsp	RES, CHIP(3216/1%/47Kohm)		CRJ14CF4702T	1	*
R734	nsp	RES, CHIP(2012/5%/0ohm)		CRJ18AJ0R0T	1	*
R735	nsp	RES, CHIP(3216/1%/47Kohm)		CRJ14CF4702T	1	*
R736,737	nsp	RES, CHIP(1608/5%/0ohm)		CRJ10DJ0R0T	2	*
R738,739	nsp	RES, CHIP(1608/5%/180ohm)		CRJ10DJ181T	2	*
R740	nsp	RES, CHIP(1608/5%/100ohm)		CRJ10DJ101T	1	*
R741-745	nsp	RES, CHIP(1608/5%/4.7ohm)		CRJ10DJ4R7T	5	*
R746,747	nsp	RES, CHIP(2012/5%/10Kohm)		CRJ18AJ103T	2	*
R748,749	nsp	RES, CHIP(2012/5%/1ohm)		CRJ18AJ1R0T	2	*
R750,751	nsp	RES, CHIP(1608/5%/75ohm)		CRJ10DJ750T	2	*
R752	nsp	RES, CHIP(1608/5%/33Kohm)		CRJ10DJ333T	1	*
R753	nsp	RES, CHIP(1608/5%/2.7Kohm)		CRJ10DJ272T	1	*
R754	nsp	RES, CHIP(1608/5%/0ohm)		CRJ10DJ0R0T	1	*
R755	nsp	RES, CHIP(1608/5%/4.7Kohm)		CRJ10DJ472T	1	*
R756	nsp	RES, CHIP(2012/5%/0ohm)		CRJ18AJ0R0T	1	*
R757	nsp	RES, CHIP(1608/5%/22Kohm)		CRJ10DJ223T	1	*
R758	nsp	RES, CHIP(1608/5%/100Kohm)		CRJ10DJ104T	1	*
R759	nsp	RES, CHIP(1608/5%/33Kohm)		CRJ10DJ333T	1	*
R760	nsp	RES, CHIP(1608/5%/100ohm)		CRJ10DJ101T	1	*
R761-764	nsp	RES, CHIP(1608/5%/22Kohm)		CRJ10DJ223T	4	*
R765,766	nsp	RES, CHIP(1608/5%/10Kohm)		CRJ10DJ103T	2	*
R768	nsp	RES, CHIP(2012/5%/0ohm)		CRJ18AJ0R0T	1	*
R771-774	nsp	RES, CHIP(1608/5%/10Kohm)		CRJ10DJ103T	4	*
R775,776	nsp	RES, CHIP(1608/5%/100Kohm)		CRJ10DJ104T	2	*
R777,778	nsp	RES, CHIP(1608/5%/0ohm)		CRJ10DJ0R0T	2	*
R783-786	nsp	RES, CHIP(1608/5%/2.2Kohm)		CRJ10DJ222T	4	*
R793-796	nsp	RES, M-OXIDE FILM(2W/10ohm)		CRG2SANJ100RT	4	*
R798	nsp	RES, CHIP(1608/5%/18Kohm)		CRJ10DJ183T	1	*
R799	nsp	RES, CHIP(2012/5%/0ohm)		CRJ18AJ0R0T	1	*
R811	nsp	RES, CHIP(1608/5%/10Kohm)		CRJ10DJ103T	1	*
R812	nsp	RES, CHIP(1608/5%/100ohm)		CRJ10DJ101T	1	*
R815	nsp	RES, CHIP(1608/5%/10Kohm)		CRJ10DJ103T	1	*
R816	nsp	RES, CHIP(1608/5%/0ohm)		CRJ10DJ0R0T	1	*
R821	nsp	RES, CHIP(1608/5%/0ohm)		CRJ10DJ0R0T	1	*
R822	nsp	RES, CHIP(1608/5%/10Kohm)		CRJ10DJ103T	1	*

REF No.	Part No.	Part Name	Remarks	Q'ty	New	Ver
R823	nsp	RES, CHIP(1608/5%/180ohm)		CRJ10DJ181T	1	*
R824	nsp	RES, CHIP(1608/5%/10Kohm)		CRJ10DJ103T	1	*
R825	nsp	RES, CHIP(1608/5%/0ohm)		CRJ10DJ0R0T	1	*
R826	nsp	RES, CHIP(1608/5%/10Kohm)		CRJ10DJ103T	1	*
R827	nsp	RES, CHIP(1608/5%/470ohm)		CRJ10DJ471T	1	*
R828	nsp	RES, CHIP(1608/5%/10Kohm)		CRJ10DJ103T	1	*
R830	nsp	RES, CHIP(1608/5%/0ohm)		CRJ10DJ0R0T	1	*
R831	nsp	RES, CHIP(1608/5%/10Kohm)		CRJ10DJ103T	1	*
R832	nsp	RES, CHIP(1608/5%/180ohm)		CRJ10DJ181T	1	*
R833	nsp	RES, CHIP(1608/5%/10Kohm)		CRJ10DJ103T	1	*
R835	nsp	RES, CHIP(1608/5%/180ohm)		CRJ10DJ181T	1	*
R836	nsp	RES, CHIP(1608/5%/470ohm)		CRJ10DJ471T	1	*
R837	nsp	RES, CHIP(1608/5%/180ohm)		CRJ10DJ181T	1	*
R838-840	nsp	RES, CHIP(1608/5%/10Kohm)		CRJ10DJ103T	3	*
R901	nsp	RES, CHIP(6432/5%/68Kohm)		CRJ01HJ683T	1	*
R902	nsp	RES, CHIP(2012/5%/0ohm)		CRJ18AJ0R0T	1	*
R903	nsp	RES, CHIP(6432/5%/1.5ohm/1W)		CRJ01HJ1R5T	1	*
R904	nsp	RES, CHIP(3216/5%/0ohm)		CRJ14CJ0R0T	1	*
R905	nsp	RES, WIRE WOUND(1W/0.55OHM)		CRW1PJR55V	1	*
R906	nsp	RES, CHIP(2012/5%/6.8ohm)		CRJ18AJ6R8T	1	*
R907	nsp	RES, CHIP(6432/5%/47ohm)		CRJ01HJ470T	1	*
R908	nsp	RES, CHIP(2012/5%/560ohm)		CRJ18AJ561T	1	*
R909	nsp	RES, CHIP(2012/5%/15Kohm)		CRJ18AJ153T	1	*
R910	nsp	RES, CHIP(2012/5%/33ohm)		CRJ18AJ330T	1	*
R911	nsp	RES, CHIP(3216/5%/1Kohm)		CRJ14CJ102T	1	*
R912	nsp	RES, CHIP(6432/5%/22ohm)		CRJ01HJ220T	1	*
R913,914	nsp	RES, WIRE WOUND		CRW1PJR15V	2	*
R915	nsp	RES, CHIP(2012/5%/100Kohm)		CRJ18AJ104T	1	*
R916	nsp	RES, CHIP(2012/5%/15Kohm)		CRJ18AJ153T	1	*
R917	nsp	RES, CHIP(2012/5%/2.7Kohm)		CRJ18AJ272T	1	*
R918	nsp	RES, CHIP(2012/5%/20Kohm)		CRJ18AJ203T	1	*
R919	nsp	RES, CHIP(2012/5%/10Kohm)		CRJ18AJ103T	1	*
R920	nsp	RES, CHIP(6432/5%/68Kohm)		CRJ01HJ683T	1	*
R921	nsp	RES, CHIP(2012/5%/560ohm)		CRJ18AJ561T	1	*
R922	nsp	RES, CHIP(2012/5%/3.9Kohm)		CRJ18AJ392T	1	*
R923	nsp	RES, CHIP(2012/5%/820Kohm)		CRJ18AJ824T	1	*
R924	nsp	RES, CHIP(2012/5%/6.8ohm)		CRJ18AJ6R8T	1	*
R925	nsp	RES, CHIP(2012/5%/0ohm)		CRJ18AJ0R0T	1	*
R926	nsp	RES, CHIP(2012/5%/2.7Kohm)		CRJ18AJ272T	1	*
R927	nsp	RES, CHIP(2012/5%/8.2Kohm)		CRJ18AJ822T	1	*
R928	nsp	RES, CHIP(3216/5%/47Kohm)		CRJ14CJ473T	1	*
R929	nsp	RES, CHIP(2012/5%/10Kohm)		CRJ18AJ103T	1	*
R930	nsp	RES, CHIP(2012/5%/47ohm)		CRJ18AJ470T	1	*
R931	nsp	RES, CHIP(2012/5%/2.2Kohm)		CRJ18AJ222T	1	*
R932	nsp	RES, CHIP(2012/5%/10Kohm)		CRJ18AJ103T	1	*
R933	nsp	RES, CHIP(2012/5%/20Kohm)		CRJ18AJ203T	1	*
R934	nsp	RES, CHIP(2012/5%/3.9Kohm)		CRJ18AJ392T	1	*
R935	nsp	RES, CHIP(2012/1%/5.6Kohm)		CRJ18AF5601T	1	*
R936	nsp	RES, CHIP(2012/5%/2.4Kohm)		CRJ18AJ242T	1	*
R937	nsp	RES, CHIP(2012/5%/1Kohm)		CRJ18AJ102T	1	*
R938	nsp	RES, CHIP(2012/5%/47ohm)		CRJ18AJ470T	1	*
R939	nsp	RES, CHIP(2012/5%/120Kohm)		CRJ18AJ124T	1	*
R940	nsp	RES, CHIP(2012/5%/47ohm)		CRJ18AJ470T	1	*
R941	nsp	RES, CHIP(2012/1%/5.6Kohm)		CRJ18AF5601T	1	*
R942	nsp	RES, CHIP(2012/5%/47ohm)		CRJ18AJ470T	1	*
R943	nsp	RES, CHIP(2012/5%/4.7Kohm)		CRJ18AJ472T	1	*
R944	nsp	RES, CHIP(2012/5%/1Kohm)		CRJ18AJ102T	1	*
R945	nsp	RES, CHIP(2012/5%/2.2Kohm)		CRJ18AJ222T	1	*
R946,947	nsp	RES, CHIP(2012/5%/6.2Kohm)		CRJ18AJ622T	2	*
R948	nsp	RES, CHIP(2012/5%/220Kohm)		CRJ18AJ224T	1	*
R949,950	nsp	RES, CHIP(2012/5%/10Kohm)		CRJ18AJ103T	2	*
R953	nsp	RES, CHIP(2012/5%/6.2Kohm)		CRJ18AJ622T	1	*
R954	nsp	RES, CHIP(2012/5%/3.3Kohm)		CRJ18AJ332T	1	*
R955	nsp	RES, CHIP(2012/5%/0ohm)		CRJ18AJ0R0T	1	*
R956-958	nsp	RES, CHIP(2012/1%/15Kohm)		CRJ18AF1502T	3	*
R959	nsp	RES, CHIP(2012/5%/1Kohm)		CRJ18AJ102T	1	*
R960	nsp	RES, CHIP(6432/5%/3.3Kohm)		CRJ01HJ332T	1	*
R963	nsp	RES, CHIP(6432/5%/100ohm)		CRJ01HJ101T	1	*
R964	nsp	RES, CHIP(2012/5%/47ohm)		CRJ18AJ470T	1	*
R965	nsp	RES, CHIP(6432/5%/3.3Kohm)		CRJ01HJ332T	1	*
R966	nsp	RES, CHIP(2012/5%/22ohm)		CRJ18AJ220T	1	*
R968	nsp	RES, CHIP(2012/5%/560ohm)		CRJ18AJ561T	1	*
R969	nsp	RES, CHIP(2012/5%/0ohm)		CRJ18AJ0R0T	1	*
R974-976	nsp	RES, CHIP(3216/5%/120Kohm)		CRJ14CJ124T	3	*
R977	nsp	RES, CHIP(2012/1%/47.5Kohm)		CRJ18AF4752T	1	*
R978	nsp	RES, CHIP(2012/1%/3.3Kohm)		CRJ18AF3301T	1	*
R979,980	nsp	RES, CHIP(2512/5%/0ohm/1W)	E3	CRJ01HJ0R0T	2	*
R991,992	nsp	RES, CHIP(2512/5%/0ohm/1W)	E2	CRJ01HJ0R0T	2	*
R993	nsp	RES, CHIP(6432/5%/3.3Kohm)		CRJ01HJ332T	1	*
R998	nsp	RES, CHIP(6432/5%/3.3Kohm)		CRJ01HJ332T	1	*
RL71,72	682010023006S	RELAY,HL3-2A-12S,DC12V,2C1P		CSL3A021ZU	2	*
RX91	nsp	RES, CHIP(3216/5%/1.5Mohm)	E3	CRJ14CJ155T	1	*
RX91	nsp	RES, CHIP(3216/5%/1.2Mohm)	E2	CRJ14CJ125T	1	*
RX92	nsp	RES, CHIP(3216/5%/1.5Mohm)	E3	CRJ14CJ155T	1	*
RX92	nsp	RES, CHIP(3216/5%/1.2Mohm)	E2	CRJ14CJ125T	1	*
RX93	nsp	RES, CHIP(3216/5%/1.5Mohm)	E3	CRJ14CJ155T	1	*
RX93	nsp	RES, CHIP(3216/5%/1.2Mohm)	E2	CRJ14CJ125T	1	*
RX94	nsp	RES, CHIP(3216/5%/1.5Mohm)	E3	CRJ14CJ155T	1	*
RX94-96	nsp	RES, CHIP(3216/5%/1.2Mohm)	E2	CRJ14CJ125T	3	*
<b>CAPACITORS GROUP</b>						
C201-206	nsp	CAP, CHIP(1608, 50V/0.1uF, X7R) SAMSUNG		CCUS1H104KCS	6	*
C208-217	nsp	CAP, CHIP(1608, 50V/0.1uF, X7R) SAMSUNG		CCUS1H104KCS	10	*
C218	nsp	CAP, CHIP(2012, 6.3V/10uF, X5R) SAMSUNG		CCUC0J106KCS	1	*
C221	nsp	CAP, CHIP(2012, 6.3V/10uF, X5R) SAMSUNG		CCUC0J106KCS	1	*
C222	nsp	CAP, CHIP(2012, 6.3V/22uF, X5R) SAMSUNG		CCUC0J226KCS	1	*
C223	nsp	CAP, CHIP(1608, 50V/3.3pF, COG) SAMSUNG		CCUS1H3R3JAS	1	*
C224	nsp	CAP, CHIP(1608, 10V/1uF, X7R, X7S) SAMSUNG		CCUS1A105KCS	1	*
C225	nsp	CAP, CHIP(1608, 50V/0.1uF, X7R) SAMSUNG		CCUS1H104KCS	1	*
C226,227	nsp	CAP, CHIP(2012, 6.3V/10uF, X5R) SAMSUNG		CCUC0J106KCS	2	*
C230	nsp	CAP, CHIP(2012, 6.3V/10uF, X5R) SAMSUNG		CCUC0J106KCS	1	*
C231	nsp	CAP, CHIP(2012, 6.3V/22uF, X5R) SAMSUNG		CCUC0J226KCS	1	*
C232	nsp	CAP, CHIP(1608, 50V/3.3pF, COG) SAMSUNG		CCUS1H3R3JAS	1	*

REF No.	Part No.	Part Name	Remarks	Q'ty	New	Ver
C233	nsp	CAP, CHIP(1608, 10V/1uF, X7R, X7S)_SAMSUNG	CCUS1A105KCS	1	*	
C234	nsp	CAP, CHIP(1608, 50V/0.1uF, X7R)_SAMSUNG	CCUS1H104KCS	1	*	
C235	nsp	CAP, CHIP(2012, 6.3V/10uF, X5R)_SAMSUNG	CCUC0J106KCS	1	*	
C250-253	943134502570M	CAP, ELEC SMD(6.3V/220uF, PVVZ Series, ESR,105°C)	CCEC0JPVWZ221T	4	*	
C501	nsp	CAP, CHIP(1608, 50V/330pF, COG)_SAMSUNG	CCUS1H331JAS	1	*	
C502	943134503100D	CAP, ELECT(16V/100uF),ELNA/RA3	CCEA1CRA38P101	1	*	
C504	nsp	CAP, CHIP(1608, 50V/330pF, COG)_SAMSUNG	CCUS1H331JAS	1	*	
C505	943134503100D	CAP, ELECT(16V/100uF),ELNA/RA3	CCEA1CRA38P101	1	*	
C507,508	943134503090D	CAP, SMD ELECT (16V/47uF), ELNA RV2	CCEC1CRV2E470T	2	*	
C510,511	nsp	CAP,ALUMINUM ELECTROLYTIC (16V/10uF)	CCEC1CMVG100T	2	*	
C513	nsp	CAP,ALUMINUM ELECTROLYTIC (16V/10uF)	CCEC1CMVG100T	1	*	
C514	nsp	CAP, CHIP(2012, 25V/2.2uF, X7R, X7S)_SAMSUNG	CCUC1E225KCS	1	*	
C515	nsp	CAP, CHIP(1608, 50V/100pF, COG)_SAMSUNG	CCUS1H101JAS	1	*	
C517	nsp	CAP, SMD ELECT(50V/1uF)	CCEC1HMVG1R0T	1	*	
C518,519	nsp	CAP, CHIP(1608, 50V/220pF, X7R)_SAMSUNG	CCUS1H222KCS	2	*	
C520	nsp	CAP, SMD ELECT(16V/22uF)	CCEC1CMVG220T	1	*	
C521	nsp	CAP, CHIP(2012, 50V/4700pF, MURATA GRM21)	CCUMUC1H472JAM	1	*	
C522,523	nsp	CAP, CHIP(3216, 50V/0.1uF, MURATA GRM31)	CCUMUP1H104JAM	2	*	
C524,525	nsp	CAP, CHIP(1608, 50V/220pF, X7R)_SAMSUNG	CCUS1H222KCS	2	*	
C527-529	nsp	CAP, CHIP(1608, 50V/100pF, COG)_SAMSUNG	CCUS1H101JAS	3	*	
C530-536	nsp	CAP, CHIP(1608, 50V/0.1uF, X7R)_SAMSUNG	CCUS1H104KCS	7	*	
C539,540	nsp	CAP, CHIP(1608, 50V/100pF, COG)_SAMSUNG	CCUS1H101JAS	2	*	
C541,542	943134503110D	CAP, ELECT(16V/470uF,ELNA/RFO)	CCEA1CRFO471E	2	*	
C543,544	nsp	CAP, CHIP(1608, 50V/0.1uF, X7R)_SAMSUNG	CCUS1H104KCS	2	*	
C545,546	nsp	CAP,ALUMINUM ELECTROLYTIC (16V/10uF)	CCEC1CMVG100T	2	*	
C547	nsp	CAP, CHIP(1608, 25V/1uF, MURATA GRM18)	CCUS1E105KC	1	*	
C548	nsp	CAP,ALUMINUM ELECTROLYTIC (16V/10uF)	CCEC1CMVG100T	1	*	
C549	nsp	CAP, CHIP(1608, 25V/1uF, MURATA GRM18)	CCUS1E105KC	1	*	
C550	nsp	CAP, SMD ELECT(16V/22uF)	CCEC1CMVG220T	1	*	
C551	nsp	CAP, CHIP(1608, 50V/330pF, COG)_SAMSUNG	CCUS1H331JAS	1	*	
C552	943134503100D	CAP, ELECT(16V/100uF),ELNA/RA3	CCEA1CRA38P101	1	*	
C554	nsp	CAP, CHIP(1608, 50V/330pF, COG)_SAMSUNG	CCUS1H331JAS	1	*	
C555	943134503100D	CAP, ELECT(16V/100uF),ELNA/RA3	CCEA1CRA38P101	1	*	
C557,558	943134503090D	CAP, SMD ELECT (16V/47uF), ELNA RV2	CCEC1CRV2E470T	2	*	
C560,561	nsp	CAP,ALUMINUM ELECTROLYTIC (16V/10uF)	CCEC1CMVG100T	2	*	
C564	nsp	CAP, CHIP(2012, 25V/2.2uF, X7R, X7S)_SAMSUNG	CCUC1E225KCS	1	*	
C571	nsp	CAP, CHIP(2012, 50V/4700pF, MURATA GRM21)	CCUMUC1H472JAM	1	*	
C572,573	nsp	CAP, CHIP(3216, 50V/0.1uF, MURATA GRM31)	CCUMUP1H104JAM	2	*	
C574,575	nsp	CAP, CHIP(1608, 50V/100pF, X7R)_SAMSUNG	CCUS1H102KCS	2	*	
C586	nsp	CAP,ALUMINUM ELECTROLYTIC (16V/10uF)	CCEC1CMVG100T	1	*	
C587	nsp	CAP, CHIP(1608, 25V/1uF, MURATA GRM18)	CCUS1E105KC	1	*	
C588	nsp	CAP,ALUMINUM ELECTROLYTIC (16V/10uF)	CCEC1CMVG100T	1	*	
C589	nsp	CAP, CHIP(1608, 25V/1uF, MURATA GRM18)	CCUS1E105KC	1	*	
C590	nsp	CAP, CHIP(1608, 50V/0.1uF, X7R)_SAMSUNG	CCUS1H104KCS	1	*	
C596	nsp	CAP, CHIP(1608, 50V/0.1uF, X7R)_SAMSUNG	CCUS1H104KCS	1	*	
C598	nsp	RES, CHIP(1608/5%/0ohm)	CRJ10DJ0R0T	1	*	
C701	nsp	CAP, ELECT(50V/100uF)	CCEA1HH101T	1	*	
C703	nsp	CAP, ELECT(50V/100uF)	CCEA1HH101T	1	*	
C704-707	nsp	CAP, CHIP(1608, 50V/220pF, MURATA GRM18)	CCUMUS1H222JAM	4	*	
C708,709	nsp	CAP, CHIP(1608, 50V/100pF, MURATA GRM18)	CCUMUS1H102JAM	2	*	
C710	nsp	CAP, CHIP(2012, 10V/4.7uF, Y5V)_SAMSUNG	CCUC1A475ZFS	1	*	
C711,712	nsp	CAP, CHIP(2012, 10V/2.2uF, X5R)_SAMSUNG	CCUC1A225KCS	2	*	
C714	nsp	CAP, CHIP(3216, 100V/0.1uF, MURATA GRM31)	CCUMUP2A104JAM	1	*	
C715-718	nsp	CAP, CHIP(2012, 100V/0.1uF, X7R)_SAMSUNG	CCUC2A104KCS	4	*	
C719,720	943134503120D	CAP, ELECT (UTWYZ, 25V/100uF, 12.5x20),105°C	CCEA1EUTWYZ102	2	*	
C721,722	943131000010D	CAP,METAL-FILM(100V/1uF)	CCME2A105JXT	2	*	
C723,724	nsp	CAP, CHIP(3216, 100V/0.1uF, MURATA GRM31)	CCUMUP2A104JAM	2	*	
C727-730	nsp	CAP, CHIP(1608, 50V/150pF, COG)_SAMSUNG	CCUS1H151JAS	4	*	
C731	nsp	CAP, ELECT(50V/100uF)	CCEA1HH101T	1	*	
C733	nsp	CAP, ELECT(50V/100uF)	CCEA1HH101T	1	*	
C734-737	nsp	CAP, CHIP(1608, 50V/220pF, MURATA GRM18)	CCUMUS1H222JAM	4	*	
C738	nsp	CAP, CHIP(2012, 10V/4.7uF, Y5V)_SAMSUNG	CCUC1A475ZFS	1	*	
C739,740	nsp	CAP, CHIP(1608, 50V/100pF, MURATA GRM18)	CCUMUS1H102JAM	2	*	
C741,742	nsp	CAP, CHIP(2012, 10V/2.2uF, X5R)_SAMSUNG	CCUC1A225KCS	2	*	
C743	nsp	CAP, CHIP(3225, 120V/0.47uF)	CCUR2B474KC	1	*	
C744	nsp	CAP, CHIP(3216, 100V/0.1uF, MURATA GRM31)	CCUMUP2A104JAM	1	*	
C745-748	nsp	CAP, CHIP(2012, 100V/0.1uF, X7R)_SAMSUNG	CCUC2A104KCS	4	*	
C749,750	943134503120D	CAP, ELECT (UTWYZ, 25V/100uF, 12.5x20),105°C	CCEA1EUTWYZ102	2	*	
C751,752	943131000010D	CAP,METAL-FILM(100V/1uF)	CCME2A105JXT	2	*	
C753,754	nsp	CAP, CHIP(3216, 100V/0.1uF, MURATA GRM31)	CCUMUP2A104JAM	2	*	
C755,756	nsp	CAP, CHIP(1608, 50V/0.01uF, X7R)_SAMSUNG	CCUS1H103KCS	2	*	
C758	nsp	CAP, ELECT(10V/330uF)	CCEA1AH331T	1	*	
C759,760	nsp	CAP, CHIP(1608, 100V/100pF, MURATA GRM18)	CCUMUS2A102JAM	2	*	
C761	nsp	CAP, CHIP(3216, 100V/0.1uF, MURATA GRM31)	CCUMUP2A104JAM	1	*	
C762	nsp	CAP, CHIP(3216, 100V/0.01uF, MURATA GRM31)	CCUMUP2A103JAM	1	*	
C763	nsp	CAP, CHIP(1608, 100V/100pF, MURATA GRM18)	CCUMUS2A102JAM	1	*	
C764	nsp	CAP, CHIP(3216, 100V/0.1uF, MURATA GRM31)	CCUMUP2A104JAM	1	*	
C765	nsp	CAP, CHIP(3216, 100V/0.01uF, MURATA GRM31)	CCUMUP2A103JAM	1	*	
C766	nsp	CAP, CHIP(1608, 100V/100pF, MURATA GRM18)	CCUMUS2A102JAM	1	*	
C767	nsp	CAP, CHIP(3216, 100V/0.1uF, MURATA GRM31)	CCUMUP2A104JAM	1	*	
C768	nsp	CAP, CHIP(3216, 100V/0.01uF, MURATA GRM31)	CCUMUP2A103JAM	1	*	
C769	nsp	CAP, CHIP(1608, 100V/100pF, MURATA GRM18)	CCUMUS2A102JAM	1	*	
C770	nsp	CAP, CHIP(3216, 100V/0.1uF, MURATA GRM31)	CCUMUP2A104JAM	1	*	
C771	nsp	CAP, CHIP(3216, 100V/0.01uF, MURATA GRM31)	CCUMUP2A103JAM	1	*	
C772	nsp	CAP, CHIP(1608, 100V/100pF, MURATA GRM18)	CCUMUS2A102JAM	1	*	
C773,774	nsp	CAP, ELECT(25V/100uF, 6.3X11, KLH)	CCEA1EKLH101TKS	2	*	
C775	nsp	CAP, CHIP(1608, 50V/0.1uF, X7R)_SAMSUNG	CCUS1H104KCS	1	*	
C776	nsp	CAP, ELECT(10V/100uF)	CCEA1AH101T	1	*	
C777	nsp	CAP, CHIP(1608, 50V/0.1uF, X7R)_SAMSUNG	CCUS1H104KCS	1	*	
C778	nsp	CAP, ELECT(10V/100uF)	CCEA1AH101T	1	*	
C779-782	nsp	CAP, CHIP(2012, 100V/0.1uF, X7R)_SAMSUNG	CCUC2A104KCS	4	*	
C783	nsp	CAP, CHIP(2012, 100V/0.022uF, X7R)_SAMSUNG	CCUC2A223KCS	1	*	
C784	nsp	CAP, CHIP(2012, 100V/100pF, X7R)_SAMSUNG	CCUC2A102KCS	1	*	
C785	nsp	CAP, CHIP(3225, 120V/0.47uF)	CCUR2B474KC	1	*	
C786	nsp	CAP, CHIP(2012, 100V/0.022uF, X7R)_SAMSUNG	CCUC2A223KCS	1	*	
C787	nsp	CAP, CHIP(2012, 100V/100pF, X7R)_SAMSUNG	CCUC2A102KCS	1	*	
C788	nsp	CAP, CHIP(3225, 120V/0.47uF)	CCUR2B474KC	1	*	
C789	nsp	CAP, CHIP(2012, 100V/0.022uF, X7R)_SAMSUNG	CCUC2A223KCS	1	*	
C790	nsp	CAP, CHIP(2012, 100V/100pF, X7R)_SAMSUNG	CCUC2A102KCS	1	*	
C791	nsp	CAP, CHIP(1608, 50V/0.1uF, X7R)_SAMSUNG	CCUS1H104KCS	1	*	
C792	nsp	CAP, ELECT(25V/100uF)	CCEA1EH101T	1	*	
C793	nsp	CAP, CHIP(1608, 50V/0.1uF, X7R)_SAMSUNG	CCUS1H104KCS	1	*	

REF No.	Part No.	Part Name	Remarks	Q'ty	New	Ver
C794	nsp	CAP, CHIP(3225, 120V/0.47uF)		CCUR2B474KC	1	*
C795,796	nsp	CAP, CHIP(1608, 100V/1000pF, MURATA GRM18)		CCUMUS2A102JAM	2	*
C797	nsp	CAP, CHIP(2012, 100V/0.022uF, X7R)_SAMSUNG		CCUC2A223KCS	1	*
C798	nsp	CAP, ELECT(25V/100uF)		CCEA1EH101T	1	*
C799	nsp	CAP, CHIP(2012, 100V/1000pF, X7R)_SAMSUNG		CCUC2A102KCS	1	*
C811-813	nsp	CAP, CHIP(1608, 50V/1000pF, X7R)_SAMSUNG		CCUS1H102KCS	3	*
C814	nsp	CAP, CHIP(1608, 50V/0.1uF, X7R)_SAMSUNG		CCUS1H104KCS	1	*
C815-817	nsp	CAP, CHIP(1608, 50V/0.01uF, X7R)_SAMSUNG		CCUS1H103KCS	3	*
C821-823	nsp	CAP, CHIP(1608, 50V/0.1uF, X7R)_SAMSUNG		CCUS1H104KCS	3	*
C831-833	nsp	CAP, CHIP(1608, 50V/0.1uF, X7R)_SAMSUNG		CCUS1H104KCS	3	*
C851,852	nsp	CAP, ELECT(16V/100uF)		CCEA1CH101T	2	*
C853,854	nsp	CAP, CHIP(1608, 50V/0.1uF, X7R)_SAMSUNG		CCUS1H104KCS	2	*
C855-858	nsp	CAP, CHIP(1608, 50V/100pF, COG)_SAMSUNG		CCUS1H101JAS	4	*
C861,862	nsp	CAP, ELECT(10V/100uF)		CCEA1AH101T	2	*
C901	943134503130D	CAP, ELECT (470uF/250V, 105°C, 25.4X35)	E3	CCET250VTD4471N	1	*
C901	943134503140D	CAP, ELECT(450V/330uF, 105°C, 30X40)	E2	CCET450VTD4331N	1	*
C902	943134503130D	CAP, ELECT (470uF/250V, 105°C, 25.4X35)	E3	CCET250VTD4471N	1	*
C903	nsp	CAP, CHIP(2012, 50V/0.47uF, X7R)_SAMSUNG		CCUC1H474KCS	1	*
C904	nsp	CAP, CHIP(2012, 50V/1uF, X7R, X7S)_SAMSUNG		CCUC1H105KCS	1	*
C905	nsp	CAP, CHIP(2012, 50V/1000pF, X7R)_SAMSUNG		CCUC1H102KCS	1	*
C906	nsp	CAP, CHIP(2012, 50V/2200pF, X7R)_SAMSUNG		CCUC1H222KCS	1	*
C907	nsp	CAP, CHIP(2012, 50V/68pF, COG)_SAMSUNG		CCUC1H680JAS	1	*
C908	943132100530D	CAP, CERAMIC(1KV/220pF/K)		CCKT3A221KBL	1	*
C909	nsp	CAP, CHIP(3216, 1KV/1000pF, X7R)_SAMSUNG		CCUP3A102KCS	1	*
C911	nsp	CAP, CHIP(2012, 50V/1000pF, X7R)_SAMSUNG		CCUC1H102KCS	1	*
C913	nsp	CAP, CHIP(2012, 25V/2.2uF, X7R, X7S)_SAMSUNG		CCUC1E225KCS	1	*
C914	nsp	CAP, CHIP(3216, 1KV/2200pF, X7R)_SAMSUNG		CCUP3A222KCS	1	*
C915	nsp	CAP, CHIP(2012, 50V/820pF, COG)_SAMSUNG		CCUC1H821JAS	1	*
C916	nsp	CAP, CHIP(2012, 50V/1uF, X7R, X7S)_SAMSUNG		CCUC1H105KCS	1	*
C918	nsp	CAP, CHIP(2012, 50V/1uF, X7R, X7S)_SAMSUNG		CCUC1H105KCS	1	*
C920,921	nsp	CAP, ELECT(50V/47uF),105°C		CCEA1HH470TCS	2	*
C923,924	943134503150D	CAP, ELECT (10V/1000uF)105°C, NXH Series		CCEA1ANXH102ES	2	*
C925	943134503160D	CAP, ELECT (25V/470uF, 10x12.5)105°C, NHA Series		CCEA1ENHA471ES	1	*
C926	nsp	CAP, CHIP(2012, 50V/0.1uF, X7R)_SAMSUNG		CCUC1H104KCS	1	*
C927	nsp	CAP, CHIP(2012, 50V/1uF, X7R, X7S)_SAMSUNG		CCUC1H105KCS	1	*
C928,929	943134503170D	CAP, ELECT (35V/220uF)105°C, NXH Series		CCEA1VNXH222ES	2	*
C930	nsp	CAP, CHIP(3216, 50V/0.1uF, MURATA GRM31)		CCUMUP1H104JAM	1	*
C931	nsp	CAP, CHIP(2012, 50V/0.1uF, X7R)_SAMSUNG		CCUC1H104KCS	1	*
C932	943134503180D	CAP, ELECT(50V/47uF),6.3X11L,KLH		CCEA1HKLH470TK3	1	*
C933	943134503190D	CAP, ELECT (35V/220uF, 10x12.5)105°C, LXZ Series		CCEA1VLXZ221ES	1	*
C934	nsp	CAP, ELECT(50V/47uF),105°C		CCEA1HH470TCS	1	*
C935	nsp	CAP, CHIP(2012, 50V/0.1uF, X7R)_SAMSUNG		CCUC1H104KCS	1	*
C936	nsp	CAP, CHIP(2012, 50V/0.01uF, X7R)_SAMSUNG		CCUC1H103KCS	1	*
C937	943134503200D	CAP, ELECT(25V/330uF, 10X12.5, KLH)		CCEA1EKLH331TK3	1	*
C938,939	nsp	CAP, CHIP(2012, 50V/0.1uF, X7R)_SAMSUNG		CCUC1H104KCS	2	*
C940	nsp	CAP, CHIP(2012, 50V/0.01uF, X7R)_SAMSUNG		CCUC1H103KCS	1	*
C941,942	nsp	CAP, CHIP(3216, 1KV/1000pF, X7R)_SAMSUNG		CCUP3A102KCS	2	*
C943-945	nsp	CAP, CHIP(2012, 50V/0.1uF, X7R)_SAMSUNG		CCUC1H104KCS	3	*
C946,947	943134503210D	CAP, ELECT (35V/470uF, 10x16)105°C, NHA Series		CCEA1VNH4471ES	2	*
C948-950	nsp	CAP, CHIP(2012, 50V/0.1uF, X7R)_SAMSUNG		CCUC1H104KCS	3	*
C951	nsp	CAP, CHIP(2012, 50V/100pF, COG)_SAMSUNG		CCUC1H101JAS	1	*
C953	943134503190D	CAP, ELECT (35V/220uF, 10x12.5)105°C, LXZ Series		CCEA1VLXZ221ES	1	*
C954	nsp	CAP, CHIP(2012, 50V/0.01uF, COG)_SAMSUNG		CCUC1H103JAS	1	*
C955	943134503180D	CAP, ELECT(50V/47uF),6.3X11L,KLH		CCEA1HKLH470TK3	1	*
C956	nsp	CAP, CHIP(3216, 50V/0.1uF, MURATA GRM31)		CCUMUP1H104JAM	1	*
C957	nsp	CAP, CHIP(2012, 50V/0.01uF, COG)_SAMSUNG		CCUC1H103JAS	1	*
C958	nsp	CAP, CHIP(2012, 50V/0.1uF, X7R)_SAMSUNG		CCUC1H104KCS	1	*
C959	nsp	CAP, CHIP(2012, 50V/0.01uF, X7R)_SAMSUNG		CCUC1H103KCS	1	*
C961	nsp	CAP, CHIP(2012, 50V/0.1uF, X7R)_SAMSUNG		CCUC1H104KCS	1	*
C962	nsp	CAP, CHIP(2012, 50V/0.01uF, X7R)_SAMSUNG		CCUC1H103KCS	1	*
C974	nsp	CAP, CHIP(2012, 50V/0.22uF, X7R)_SAMSUNG		CCUC1H224KCS	1	*
<b>OTHER PARTS GROUP</b>						
CK57	nsp	WAFER, SMD (2MM PITCH)		CJP05GA208ZY	1	*
CN52	nsp	PIN SOCKET (07P,1.25mm,ANGLE,B-TO-B)		CJP07HJ282Z	1	*
CN53	nsp	PIN SOCKET (27P,1.25mm,ANGLE,B-TO-B)		CJP27HJ282Z	1	*
CN54	nsp	WAFER, FCC, SMD(11P-1mm, STRAIGHT)		CJP11GA193ZY	1	*
! CN91	943641500240D	INLET, AC, NON-POL (250V/2.5A PCB MOUNT TYPE)		CJJA0A19Z	1	*
CN92	nsp	WIRE ASSY(13PIN, 80MM)		CWB1B01308047	1	*
CN93	nsp	WAFER, 2P, 3.96mm		CJP02KA060ZY	1	*
CN94	nsp	WAFER (3.96MM)		CJP03GA1482W	1	*
! CX91	943134503220D	CAP, X2(275VAC, 0.22uF, 12mm, SEORYONG)		CCQF2E224KZFS	1	*
! CX92,93	943134503230D	CAP, X2(275VAC, 0.33uF, 15mm, 18X14.5X8, SMALL)		CCQF2E334KXES	2	*
! CY91,92	943132100540D	CAP, CERAMIC (400V Y-CAP)		CCKDHS102ME	2	*
! CY95	943132100540D	CAP, CERAMIC (400V Y-CAP)		CCKDHS102ME	1	*
! CY96,97	90M-DK100880R	CAP, CERAMIC (400V Y-CAP)		CCKDHS471ME	2	*
BD92	nsp	BEAD, CORE(100MHz MIN 120ohm)		CLZ9H002Z	1	*
BD94	nsp	FERRITE CHIP BEAD(4516/60R)		CLZ9Z014Z	1	*
BK91	nsp	BRACKET, PCB M3		CMD1A834	1	*
BN13	nsp	WAFER, ANGLE, 7PIN		CJP07GB46ZY	1	*
BN14	nsp	PIN HEADER (09P,1.25mm,STRAIGHT,B-TO-B)		CJP09GI281Z	1	*
BN21	nsp	PIN HEADER (27P,1.25mm,STRAIGHT,B-TO-B)		CJP27GI281Z	1	*
BN43	nsp	WIRE ASSY (5P, 250mm, 2.0mm, ANGLE, UL TUBE)		CWB1B005250AA6C	1	*
BN52	nsp	PIN HEADER (07P,1.25mm,STRAIGHT,B-TO-B)		CJP07GI281Z	1	*
BN53	nsp	PIN HEADER (27P,1.25mm,STRAIGHT,B-TO-B)		CJP27GI281Z	1	*
BN57	nsp	WIRE ASSY (5P, 50mm, 2.0mm)		CWB1B005050AA7	1	*
BN71	nsp	WIRE ASSY (3P, 170mm, 3.96mm)		CWB4E00317OZZ	1	*
BN91	nsp	WIRE ASSY (2P, 80MM, FERRITE CORE)		CWB4F003080VZ00	1	*
BN92	nsp	LOCKING TYPE, STRAIGHT WAFER, 2MM		CJP13GI236ZW	1	*
BN94	nsp	WIRE ASSY (3P, 90mm, 3.96mm)		CWB4F003090VZ	1	*
ET51	nsp	BRACKET, PCB		CMD2A569-V1	1	*
F901	nsp	HOLDER, FUSE		KJCFCS5	2	*
GND1	nsp	PLATE, EARTH(TRONIC ELECTRONICS)		CJT1A026	1	*
HS91	nsp	HEAT SINK		CMY1A418	1	*
JK51	943643103020D	JACK, AUX(3.5mm MINI, 4P, SILVER PLATE)		CJJD031Z	1	*
JK52	00D9430191700	JACK, IN/OUT		CJJ4N034Z	1	*
JK56	nsp	JACK, BOARD		CJJ4M046Z	1	*
JK71,72	943643102490M	2P, SCREW SPK(R/B,GOLD,94V-0,Transparence)		CJJ5N025Z	2	*
L201-208	nsp	FERRITE CHIP BEAD(2012/220R, CB05YTYH221)		CLZ9R018V	8	*
L501	nsp	FERRITE CHIP BEAD(2012/220R, CB05YTYH221)		CLZ9R018V	1	*
L521	nsp	FERRITE CHIP BEAD(2012/220R, CB05YTYH221)		CLZ9R018V	1	*
L535-540	nsp	FERRITE CHIP BEAD(2012/220R, CB05YTYH221)		CLZ9R018V	6	*
L551	nsp	FERRITE CHIP BEAD(2012/220R, CB05YTYH221)		CLZ9R018V	1	*

REF No.	Part No.	Part Name	Remarks		Q'ty	New	Ver
L701-704	943115100610D	INDUCTOR, 22uH(SAGAMI)		CLZ9Z201Z	4	*	
L711	nsp	FERRITE CHIP BEAD(2012/220R, CB05YTYH221)		CLZ9R018V	1	*	
L811-814	nsp	FERRITE CHIP BEAD(2012/220R, CB05YTYH221)		CLZ9R018V	4	*	
L924	nsp	BEAD, CORE(BFD 3510 R2F RADIAL)		CLZ9Z192Z	1	*	
L925-928	nsp	FERRITE ,CHIP BEAD(60ohm, 2012)		CLZ9R001Z	4	*	
L929,930	943111003330S	COIL , CHOKE(7UH)		CLZ9Z090Z	2	*	
LF91,92	nsp	FILTER , LINE(10.0mH, 3.0A)		CLZ9Z191Z	2	*	
! PC91-95	943239101480S	I.C , PHOTO COUPLER (4P, SMD)		CVIEL817S1	5	*	
S501	943662101010D	SW, TACT, VERTICAL (BLACK, 3.3mm)		CST1A035ZT	1	*	
S815-817	943662101020D	SW, TACT (SMD, H=1.5mm, 160GF)		CST1A036ZT	3	*	
! TF91	943101102650D	TRANS , SWITCHING(EFD3030)		CLT9Z109ZW	1	*	
! TF92	943101102660D	TRANS , SWITCHING(EER3541)		CLT9Z110ZW	1	*	
TH91	00D9430035206	NTC , THERMISTOR (10MM PITCH)		KRT5D15MSFC	1	*	
TS92	nsp	WAFER/STRAIGHT/2.5mm/2P		CJP02GA01ZY	1	*	
! VT91,92	943251101000D	VARISTOR, (10MM, 560V)		CRVINR10D561SCC	2	*	
★	nsp	HEAT SINK (25mm)		CMY5A222-V2	1	*	
★	nsp	DIODE , FAST RECOVERY (400V/20A,TO-220)		CVDFCU20A40	1	*	
★	nsp	HEAT SINK (25mm)		CMY5A222-V2	1	*	
★	nsp	DIODE , FAST RECOVERY (400V/20A,TO-220)		CVDFCU20A40	1	*	
★	nsp	PROTECTOR , THERMAL ASS'Y		CRTST22110070WZ	1	*	
★	nsp	PROTECTOR , THERMAL (110'C, 70mm)		CRTST22110070W	1	*	
★	nsp	PROTECTOR , THERMAL ASS'Y (110'C, 70mm)		CRTST22110070WA	1	*	
★	nsp	SCREW		CTB3+8JR	1	*	
★	nsp	SCREW		CTB3+8JR	1	*	
★	nsp	SCREW		CTB3+10JR	1	*	
★	nsp	BRACKET , THERMAL SENSOR		CMD1A720	1	*	
★	nsp	INSULATOR , SILICON		CMX1A164	1	*	
★	nsp	FERRITE , CORE		CLZ9Z070Z	1	*	
★	nsp	FERRITE , CORE		CLZ9Z071Z	2	*	

## EXPLODED

※Parts indicated by "nsp"on this table cannot be supplied.

※The parts listed below are only for maintenance. Therefore they might differ from the parts used in the unit in appearances or dimensions.

NOTE:The symbols in the column Remarks indicate the following destinations.

E3 : U.S.A. & Canada model E2 : Europe model E1C : China model E1 : Asia model JP : Japan model  
BK : Black model SP : Premium Silver model

REF No.	Part No.	Part Name	Remarks	Q'ty	New	Ver
C15	943639101670D	HEOSAMPE2/E3, DIGITAL PCB ASS'Y	COP12667C	1	*	
★	943639101680D	MAIN PCB ASSY(E3)	CUP12669E	1	*	
★	943639101830D	MAIN PCB ASSY(E2)	CUP12669C	1	*	
└C1	nsp	MAIN PCB MAIN (VOLUME / SMPS)	CUP12669Z-1			
└C6	nsp	MAIN PCB SUB SMPS	CUP12669Z-2			
└C8	nsp	MAIN PCB CONNECT	CUP12669Z-3			
└C9	nsp	MAIN PCB FRONT LED	CUP12669Z-4			
└C10	nsp	MAIN PCB REAR LED	CUP12669Z-5			
└C11	nsp	MAIN PCB SIDE KEY	CUP12669Z-6			
└C12	nsp	MAIN PCB AC INLET	CUP12669Z-7			
└C14	nsp	MAIN PCB FRONT LED SUPPORT	CUP12669Z-8			
C16	943189100840D	CORE MODULE ASS'Y (HEOSAMP)	CNVH/AMPCOREMODULEA	1	*	
M1	nsp	PLATE 2 , WHIGHT	CMD1A914	1	*	
M10	42141002500AD	BADGE , DENON (same as DA300USB)	CGB1A277	1	*	
M11	nsp	SURPORT , PCB	CDF1A043	3	*	
M2	nsp	HEAT SINK , PLATE	CMY1A410	1	*	
M3	nsp	BOTTOM CHASSIS	CUA1A356Z	1	*	
M4	nsp	PLATE 1 , WHIGHT	CMD1A913	1	*	
M5	nsp	HEAT SINK , IC	CMY1A411	1	*	
M6	nsp	SURPORT , PCB	CDF1A040	3	*	
M8	nsp	SPEAKER_GROUND	CMD1A918	2	*	
M9	nsp	PLATE , SHIELD	CMC1A475	1	*	
P1	943402104740D	FRONT PANEL HEOSAMP	CGW1A555Z	1	*	
P2	943405101000D	COVER , BOTTOM ASS'Y	CKD1A085ZA	1	*	
└P2-1	nsp	COVER , BOTTOM	CKD1A085G80			
└P2-2	nsp	FOOT	CKL2A102			
P12	943407100530D	RUBBER , FOOT	CHG1A297Z	4	*	
P3	943403101030D	COVER , TOP ASS'Y	CKD1A086ZA	1	*	
└P3-1	nsp	COVER , TOP	CKD1A086G80			
└P3-2	nsp	AIRVENT , TOP	CKD1A087G80			
P4	943418100500D	ORNAMENT , SIDE L ASS'Y	CGRHEOSAMPSRE2L	1	*	
└P4-1	nsp	ORNAMENT , SIDE L	CGR1A572B76			
└P4-2	nsp	RING , SIDE	CGR1A573C86			
P5	943418100510D	ORNAMENT , SIDE R ASS'Y	CGRHEOSAMPSRE2R	1	*	
└P5-1	nsp	ORNAMENT , SIDE R	CGR1A571ZB76			
└P4-2	nsp	RING , SIDE	CGR1A573C86	1	*	
P6	943416101460D	LED , WINDOW	CGU1A484	1	*	
P7	nsp	HOLDER , LED	CKK1A034	1	*	
P8	943423100550D	LENS , LED	CGL1A319	1	*	
P9	943412101360D	KNOB , VOLUME	CBC1A184C84	1	*	
P10	943412101370D	KNOB , MUTE	CBC1A186ZC84	1	*	
P11	nsp	BASE , KNOB	CHG1A608	1	*	
P13	nsp	RUBBER , GUIDE	CHG1A606	12	*	
P14	nsp	SUPPORT , PCB 31	CRE1A073	1	*	
P16	nsp	SHEET , HEATSINK	CMZ1A151	1	*	
P17	nsp	RUBBER , TOP	CHG1A381	2	*	
P18	nsp	INSULATE , PCB	CMX1A345	1	*	
S2	nsp	SCREW	CTB3+6FR	23		
S3	nsp	SCREW	CTB3+10JFZR	1		
S6	nsp	SCREW , HEXA	CHD1A063ZR	2		
S7	nsp	SCREW , SPECIAL	CHD2A060R	3	*	
S8	nsp	SCREW	CTB3+6FFZR	2		
★	nsp	SCREW , SPECIAL	CHD1A110JFR	13	*	
! ★	943652500570D	FUSE(215Series, 250V/5A)	CBA2C5000TLHEY	1	*	
★	943419100950D	ANT, WIFI (2.45GHz, 240mm, WHITE, IPEX CONNECTOR)	CSA1A054Z	1	*	
★	943419100960D	ANT, WIFI (2.45GHz, 330mm, BLACK, IPEX CONNECTOR)	CSA1A055Z	1	*	
★	nsp	LABEL , BOTTOM	QCB1A1306Z	1	*	
★	nsp	SCREW	CTB3+8JFZR	12		
★	nsp	SCREW	CTS3+8JR	6		
★	nsp	BOTTOM CHASSIS ASS'Y(WEIGHT)	CUA1A356ZA	1	*	
★	nsp	SCREW	CTB3+8JFZR	12		
★	nsp	WIRE ASS'Y (7P, 200mm, 2.0mm, UL TUBE)	CWB1B007200AAE001	1	*	
★	943606004640S	CABLE , CARD (11P,1.0MM,50MM,B,10MM)	CWC4F4A11A080B10	1		

## PACKING

※Parts indicated by "nsp" on this table cannot be supplied.

※The parts listed below are only for maintenance. Therefore they might differ from the parts used in the unit in appearances or dimensions.

NOTE: The symbols in the column Remarks indicate the following destinations.

E3 : U.S.A. & Canada model E2 : Europe model E1C : China model E1 : Asia model JP : Japan model

BK : Black model SP : Premium Silver model GL : Gold model

REF No.	Part No.	Part Name	Remarks		Q'ty	New	Ver
1	943531104470D	BOX , OUT CARTON		CPG1A1035Z	1	*	
2	nsp	LABEL , CONTROL		CQB1A1274	1	*	
4	943531104760D	BOX , GIFT E3	E3	CPG1A1032Y	1	*	3
4	943531104480D	BOX , GIFT E2	E2	CPG1A1032Z	1	*	3
5	943539100850D	HANDLE,BOX(CLEAR)		CRE1A131Z	1	*	2
6	943539100860D	CLAPER,HANDLE		CRE1A130Z	1	*	2
7	943533102640D	SNOWPAD , BOTTOM		CPS1A1008	1	*	
8	943533102630D	SNOWPAD , TOP		CPS1A1007	1	*	
9	nsp	SET , 2.1CH AMP		HEOSAMPSRE3SE	1	*	
10	943534100500D	BAG , FEBRIC		CPP1A156Z	1	*	2
11	nsp	TAPE , OPP		CHS1A258Y	3	*	
!	12	943693100500D	CORD , POWER(7A/125V, USA, INLET TYPE, WHITE TIE) E3	E3	CJA2A141ZH	1	
!	12	943693100510D	CORD , POWER EUR(H03VVH2-F 2X0.75MM, TIE WHT) E2	E2	CJA2B108YV	1	*
13	nsp	INSTRUCTION MANUAL ASSY		CQXHEOSAMPSRE	1	*	
13-1	943539100870D	BOX , Accessory		CPG1A1036Z	1	*	2
13-2	943539100880D	PAD , ACCESSORY		CPS1A1011	1	*	2
13-3	943643103030D	4P MINI JACK CABLE (1500mm)		CJS9D008Z	1	*	
13-4	943612506300D	CABLE, ETHERNET, L=1500mm, W/SHELL		CJS9L014Z	1	*	
14	943539100890D	PAD , GETTING		CPS1A1026	1	*	2
15	978543104000D	SERVICE , SHEET (THANK YOU NOTE (DEL))	E3	CQE1A723Z	1	*	2
16	54311039400AD	SAFETY INSTRUCTIONS(EM)		CQE1A686Z	1	*	2
17	54311035500AD	CARD,WARRANTY	E3	CQE1A688Z	1	*	2
18	54111120500AD	MANUAL , GETTING START	E3	CQX1A1867Z	1	*	
18	54111120501AD	MANUAL , GETTING START	E2	CQX1A1868Z	1	*	
★	nsp	LOCKER		CRE1A037	2		
★	nsp	LOCKER , RED		CRE1A037Y	2		