

DENON

Hi-Fi Multi Laser Disc Player

For U.S.A. Model

SERVICE MANUAL MODEL LA-3500

MULTI LASER DISC PLAYER

Kelowna Digitronics Inc.



CONTENTS

OPERATING INSTRUCTIONS	2 - 21	EXPLODED VIEW	75 ~ 79
DISASSEMBLY AND ASSEMBLY	22 - 34	MAIN UNIT	75
ADJUSTMENT	35 - 41	FRONT PANEL	76
PICKUP AND SERVO	35 - 40	TRAY / DRIVE UNIT	77
VIDEO	41	PICK BASE / TRAVERSE	78, 79
SEMICONDUCTORS	42 - 57	CIRCUIT BLOCK DIAGRAM	80 ~ 84
P.W.B. ASS'Y PARTS LIST	58 - 68	SERVO	80
2U-2570 MAIN UNIT	59 - 62	AUDIO	81
2U-2571 SUB UNIR	62 - 67	VIDEO	82
2U-2759 TRANSFORMER UNIT	67	CONTROL	83
2U-2572 SWITCH UNIT	67	SPINDLE SERVO	84
PRINTED WIRING BOARD	68 - 73	CD-G	84
EXPLODED VIEW OF PARTS LIST	74	WIRING DIAGRAM	85
PACKING & ACCESSORIES	74	SCHEMATIC DIAGRAM	86 ~ 92

NIPPON COLUMBIA CO., LTD.

IMPORTANT TO SAFETY

WARNING:

TO PREVENT FIRE OR SHOCK HAZARD, DO NOT EXPOSE THIS APPLIANCE TO RAIN OR MOISTURE.

Please, record and retain the Model name and serial number of your set shown on the rating label
Model No. LA-3500 Serial No. _____



CAUTION
 RISK OF ELECTRIC SHOCK
 DO NOT OPEN



CAUTION: TO REDUCE THE RISK OF ELECTRIC SHOCK, DO NOT REMOVE COVER (OR BACK). NO USER SERVICEABLE PARTS INSIDE. REFER SERVICING TO QUALIFIED SERVICE PERSONNEL.

The lightning flash with arrowhead symbol within an equilateral triangle is intended to alert the user of the presence of uninsulated "dangerous voltage" within the product's enclosure that may be of sufficient magnitude to constitute a risk of electric shock to persons.

The exclamation point within an equilateral triangle is intended to alert the user of the presence of important operating and maintenance (servicing) instructions in the literature accompanying the appliance.

CAUTION

TO PREVENT ELECTRIC SHOCK DO NOT USE THIS (POLARIZED) PLUG WITH AN EXTENSION CORD, RECEPTACLE OR OTHER OUTLET UNLESS THE BLADES CAN BE FULLY INSERTED TO PREVENT BLADE EXPOSURE.

ATTENTION

POUR PREVENIR LES CHOCES ELECTRIQUES NE PAS UTILISER CETTE FICHE POLARISEE AVEC UN PROLONGATEUR UNE PRISE DE COURANT OU UNE AUTRE SORTIE DE COURANT, SAUF SI LES LAMES PEUVENT ETRE INSEREES A FOND SANS EN LAISSER AUCUNE PARTIE A DECOUVERT.

NOTE:

This Multi Laser Disk player uses the semiconductor laser. To allow you to enjoy music at a stable operation, it is recommended to use this in a room of 5°C (41°F) - 35°C (95°F).

LABELS

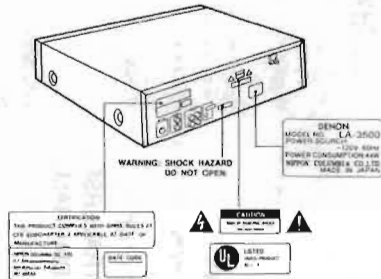

CAUTION.
USE OF CONTROLS OR ADJUSTMENTS OR REPERFORMANCE OF PROCEDURES OTHER THAN THOSE SPECIFIED HEREIN MAY RESULT IN HAZARDOUS RADIATION EXPOSURE.

THE COMPACT DISC PLAYER SHOULD NOT BE ADJUSTED OR REPAIRED BY ANYONE EXCEPT PROPERLY QUALIFIED SERVICE PERSONNEL.

NOTE:

This unit may cause interference to radio and television reception if you do not operate it in strict accordance with this OPERATING INSTRUCTIONS.

This unit complies with Class B computing device rules in accordance with the specifications in Sub-part J or Part 15 of the FCC Rules, which are designed to provide reasonable protection against such interference in a residential installation. If the unit does cause interference to any radio or television reception, try to reduce it by one or more of the following means:

- Turn the other unit to improve reception
- Move this unit
- Move this unit away from others
- Plug this unit respectively into a different AC outlet

* This is note in accordance with Section 15.838 of the FCC Rules.

IMPORTANT SAFEGUARDS

- Read Instructions - All the safety and operating instructions should be read before the appliance is operated.
- Retain Instructions - The safety and operating instructions should be retained for future reference.
- Heed Warnings - All warnings on the appliance and in the operating instructions should be adhered to.
- Follow Instructions - All operating and use instructions should be followed.
- Cleaning - Unplug this video product from the wall outlet before cleaning. Do not use liquid cleaners or aerosol cleaners. Use a damp cloth for cleaning.
- Attachments - Do not use attachments not recommended by the video product manufacturer as they may cause hazards.
- Water and Moisture - Do not use this video product near water - for example, near a bath tub, wash bowl, kitchen sink, or laundry tub, in a wet basement, or near a swimming pool, and the like.
- Accessories - Do not place this video product on an unstable cart, stand, tripod, bracket, or table. The video product may fall, causing serious injury to a child or adult, and serious damage to the appliance. Use only with a cart, stand, tripod, bracket, or table recommended by the manufacturer, or sold with the video product. Any mounting of the appliance should follow the manufacturer's instructions, and should use a mounting accessory recommended by the manufacturer.
- An appliance and cart combination should be moved with care. Quick stops, excessive force, and uneven surfaces may cause the appliance and cart combination to overturn.
- Ventilation - Slots and openings in the cabinet are provided for ventilation and to ensure reliable operation of the video product and to protect it from overheating, and these openings must not be blocked or covered. The openings should never be blocked by placing the video product on a bed, sofa, rug or other similar surface. This video product should never be placed near or over a radiator or heat register. This video product should not be placed in a built-in installation such as a bookcase or rack unless proper ventilation is provided or the manufacturer's instructions have been adhered to.
- Power Sources - This video product should be operated only from the type of power source indicated on the marking label. If you are not sure of the type of power supply to your home, consult your appliance dealer or local power company. For video products intended to operate from battery power, or other sources, refer to the operating instructions.
- Grounding or Polarization - This video product is equipped with a polarized alternating current line plug (a plug having one blade wider than the other). This plug will fit into the power outlet only one way. This is a safety feature. If you are unable to insert the plug fully into the outlet, try reversing the plug. If the plug should still fail to fit, contact your electrician to replace your obsolete outlet. Do not defeat the safety purpose of the polarized plug.
- Power Cord Protection - Power-Supply cords should be routed so that they are not likely to be walked on or pinched by items placed upon or against them, paying particular attention to cords at plugs, convenience receptacles, and the point where they exit from the appliance.
- Outdoor Antenna Grounding - If an outside antenna or cable system is connected to the video product, be sure the antenna or cable system is grounded so as to provide some protection against voltage surges and built-up static charges. Section 810 of the National Electrical Code, ANSI/NFPA No. 70-1984, provides information with respect to proper grounding of the mast and supporting structure, grounding of the lead-in wire to an antenna discharge unit, size of grounding conductors, location of antenna-discharge unit, connection to grounding electrodes, and requirements for the grounding electrode. See Figure A.
- Lightning - For added protection for this video product receiver during a lightning storm, or when it is left unattended and unused for long periods of time, unplug it from the wall outlet and disconnect the antenna or cable system. This will prevent damage to the video product due to lightning and power-line surges.
- Power Lines - An outside antenna system should not be located in the vicinity of overhead power lines or other electric light or power circuits, or where it can fall into such power lines or circuits. When installing an outside antenna system, extreme care should be taken to keep from touching such power lines or circuits as contact with them might be fatal.
- Overloading - Do not overload wall outlets and extension cords as this can result in a risk of fire or electric shock.
- Object and Liquid Entry - Never push objects of any kind into this video product through openings as they may touch dangerous voltage points or short-out parts that could result in a fire or electric shock. Never spill liquid of any kind on the video product.
- Servicing - Do not attempt to service this video product yourself as opening or removing covers may expose you to dangerous voltage or other hazards. Refer all servicing to qualified service personnel.
- Damage Requiring Service - Unplug this video product from the wall outlet and refer servicing to qualified service personnel under the following conditions:
 - When the power supply cord or plug is damaged.
 - If liquid has been spilled, or objects have fallen into the video product.
 - If the video product has been exposed to rain or water.
 - If the video product does not operate normally by following the operating instructions. Adjust only those controls that are covered by the operating instructions as an improper adjustment of other controls may result in damage and will often require extensive work by a qualified technician to restore the video product to its normal operation.
 - If the video product has been dropped or the cabinet has been damaged.
 - When the video product exhibits a distinct change in performance - this indicates a need for service.
- Replacement Parts - When replacement parts are required, be sure the service technician has used replacement parts specified by the manufacturer or have the same characteristics as the original part. Unauthorized substitutions may result in fire, electric shock or other hazards.
- Safety Check - Upon completion of any service or repairs to this video product, ask the service technician to perform safety checks to determine that the video product is in proper operating condition.

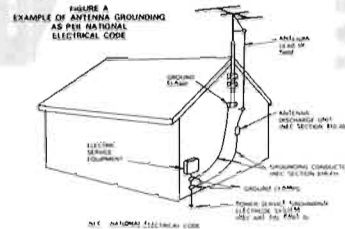

- TABLE OF CONTENTS -

1	Main Features	4
2	Notes on Installation	4
3	Notes on Use	5
4	Before Using	6
5	About Discs	7
6	Connections	10
7	Part Names and Functions	12
8	Opening and Closing the Disc Table and Loading Discs	15
9	Remote Control Unit	17
10	On-Screen Display	20
11	Regular Playback	22
12	Finding Specific Sections	24
13	Other Playback Modes	28
14	Programmed Playback	34
15	Repeat Playback	36
16	Switching the Audio Channel	38
17	Troubleshooting	39
18	Main Specifications	41

Check that the following parts are included in the package aside from the main unit:

(1) Operating Instructions	1
(2) Audio cord	1
(3) Video cord	1
(4) S-Video cord	1
(5) Remote control unit (RC-520)	1
(6) R6P (AA) batteries	2
(7) Warranty card	1

1 MAIN FEATURES

1. Double Super Linear Converter

The use of Denon's unique system and D/A converters with excellent resolution to prevent zero cross distortion, the main cause of reduced sound quality in the PCM playback system, make for sound field reproduction with rich musical expression.

2. Real 20-bit

This together with real 20-bit D/A converters of fering excellent resolution greatly improves music reproducibility, particularly at low volume levels.

3. Full digital video processing system

Digital circuitry is used for the TBC, 3-line Y/C separation and FNR (Field Noise Reduction), achieving high picture quality.

4. Digital servo for high playability

The LA-3500 uses digital servo circuitry and a digital servo processor which makes the optimum adjustment according to the condition of each individual disc, for high precision control of the servo section. This provides high tracing capacities (playability) and reduces access time.

5. CD-G (CD-graphics) compatible

6. Numerous functions

- Jog/shuttle functions
- Strobe, still & sound and art play functions
- Random, auto edit and intro-scan functions

2 NOTES ON INSTALLATION

The sound or picture of the tuner or TV may be affected when using this digital audio component or an electronic device equipped with a microprocessor simultaneously with a tuner or TV.

- Install the LA-3500 as far as possible from the tuner or TV.
- Keep the tuner and TV's antenna cords as far as possible from the LA-3500's power cord and input/output connection cords.
- Interference is especially likely when using a 300 ohm feeder wire for an indoor antenna. We recommend using an outdoor antenna and 75 ohm coaxial cables.

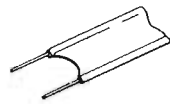

300 ohm feeder wire



75 ohm coaxial cable

NOTE ON USE

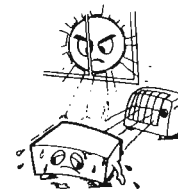

Be careful of high temperatures

- Do not place the set in a location where it will be exposed to direct sunlight or near a heating appliance.

Caution on rack/cabinet installation

- Avoid installing the set in a closed-type rack.
- When installing in a rack or cabinet, provide a sufficiently large ventilation opening to promote heat radiation.



Do not allow foreign matter into the equipment

- Be especially careful of needles, hair pins, and coins getting into the set.



Caution on humidity, water, and dust

- Do not place the set in a location where there is high humidity or a lot of dust.

Flower vases or other items containing water should not be placed on top of the set.

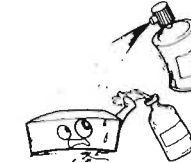

Care of the case

- Avoid the use of pesticides near the set as well as wiping the case with benzine, thinner or other solvents since they may cause a change in quality or color. Use a soft cloth when wiping away dirt and follow the instructions carefully when using chemically treated cloths.



Do not open the case

- Opening the top cover or the bottom plate of the case and inserting your hand is dangerous. Do not open the case.

If some trouble arises with the performance of the set, remove the power plug soon and contact the store where the set was purchased or a nearby dealer.

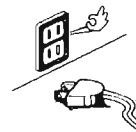

During your absence

- When not using the set for an extended period such as when taking a trip, be sure to disconnect the plug from the receptacle.

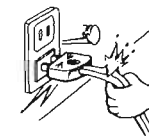

Care with the power cord

- When removing the plug from the receptacle, do not pull the power cord; be sure to hold the plug when removing it.



For sets with ventilation holes

Do not block the ventilation holes of the set

- Blocking of the ventilation holes will lead to damage of the set.
- The ventilation holes are very important for heat radiation from within the set. Care must be taken since placing an object against the holes will result in an extreme rise of temperature within the set.

4 BEFORE USING

Check the following points before using the LA-3500:

- Before turning on the power
Be sure the POWER button is off when connecting or disconnecting connection cords. Check again that all connections are proper and that there are no problems with the connection cords.
- Moving the set
Remove discs before moving the set. To prevent short-circuiting or damage to connection cords, always unplug the power cord and disconnect all cords connecting the LA-3500 to other audio components before moving the set.
- Wait until "STANDBY" appears on the display before unplugging the power cord.

- Keep these operating instructions
After reading these operating instructions, store them in a safe place along with the warranty. Also fill in the necessary items on the back cover for future reference.
- LD players use semiconductor lasers. To ensure stable operation, the player should be used at a room temperature between 5°C (41°F) and 35°C (95°F).
- The illustrations used for explanations in these instructions may differ slightly from the actual set.

Cautions on Handling

Be sure to read this section before using the LA-3500.

If stripes appear on the TV screen

Depending on the reception conditions of TV programs, stripes may appear on the TV screen when watching a program with the player's power turned on. This is not a malfunction of the player or TV. Turn off the player's power when watching TV programs.



Condensation

Condensation or dew may form on the operation sections or lens if the player is brought into a warm room from the cold outdoors or if the temperature in the room increases suddenly. If this happens, the laser beam will not be able to read signals and discs will not play. Depending on how heavy the dew is, leave the power on for one or two hours to let the player get accustomed to the temperature in the room. The dew will evaporate and playback will be possible. Dew may also form in the summer if the player is exposed to the direct airflow from an air conditioner. If so, move the player out of the airflow.



5 ABOUT DISCS

Handling Discs

Holding Discs

Avoid touching the surface of the disc when loading or unloading it.

Holding Laser Discs

• When holding with both hands:
Hold the disc along the edges.

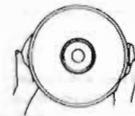

Figure A

• When holding with one hand:
Hold the disc with one finger in the hole in the middle and another along the edge.



Figure B

Holding Compact Discs and Compact Discs with video (CDVs)

Hold the disc along the edges as shown in Figure C.



Figure C

NOTE:
Do not use cracked or warped discs.

- The disc rotates at high speed inside the player during playback.
Do not use cracked, chipped or strongly warped discs, as they may damage the player.

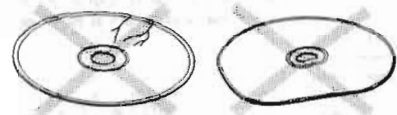

Cleaning

Fingerprints and dirt do not directly affect the signals recorded on the disc, but may reduce the light reflected from the signal surface and reduce the sound or picture quality. Clean the disc if it is dirty. To clean a disc, apply some water to a soft cloth, wring out well, wipe off the dirt, then wipe the disc with a dry cloth. Wipe the disc from the inner side towards the outer side.

Do not wipe in a circle.



Wipe gently from the inner side towards the outer side.

Do not use record spray or anti-static materials. Also, never use benzene, thinner, or other volatile chemicals.



NOTE:



The picture may be interrupted if the disc is extremely dirty. If this happens, clean the disc.

Types of Discs Usable on the LA-3500

The LA-3500 is a multi disc player.
The 9 types of disc listed below can be played.
• The marks are included on the disc's label or jacket.

Mark	Disc	Size	Side(s) recorded	Audio recording format	Video recording format	Others
	CD (Compact Disc) Single	8cm	One side	Digital	—	TOC (*1)
	CD (Compact Disc)	12cm	One side	Digital	—	TOC
	CD Graphics Single	8cm	One side	Digital	CD-G (*5)	TOC
	CD Graphics	12cm	One side	Digital	CD-G	TOC
 CDV or 	CDV Video Single VIDEO SINGLE DISC	12cm	One side	Digital (max. 5 minutes)	CLV (*3) (max. 5 minutes)	TOC
	CDV (CD Video)	12cm	One side	Digital (max. 20 minutes)	CLV (*3) (max. 5 minutes)	TOC
 LD CD VIDEO	LD with TOC (CD Video LD)	20cm Single	One side	Digital/Analog	CAV (*2) CLV	TOC
		20cm	Both sides			
 or 	LD (Laser Disc)	30cm	One side	Digital/Analog (*4) or analog only	CAV, CLV	—

The LA-3500 is a player conforming to NTSC standards.
Discs for other TV formats (PAL or SECAM) cannot be used on the LA-3500.

Terminology

LD Terminology

Chapter numbers

The chapter numbers are numbers given to different sections of the disc, something like chapters in a book. If chapter numbers are recorded on the disc, you can use them for such operations as chapter search for finding certain sections quickly.

- Some discs do not include chapter numbers.

Frame numbers

These are numbers recorded for each frame of CAV discs. Use them for such operations as frame search for finding a certain scene using the frame numbers.

Time numbers

The time numbers indicate the elapsed playing time from the beginning of the disc, and are recorded on CLV discs. They make it possible to use such operations as time number search for finding a certain scene using the time numbers.

CD/CDV/CD-G Terminology

Track numbers

Track numbers are numbers given to the different sections of the disc. CDV discs contain track numbers for both the audio and video part. Use the track numbers for such operations as track search for finding the desired section of the disc quickly.

TOC (*1)

Aside from the audio signals, all CD, CDV and CD-G discs contain data called the "TOC" (Table Of Contents) at the beginning of the disc. As the name implies, this is like the table of contents in a book, and includes information on the number of tracks and the playing times.

- Some LD discs also include TOCs.

LDs (Laser Discs)

Discs including the marks shown at the right can be used on the LA-3500.



These are standard laser disc marks. Players and discs including these laser disc marks are compatible, as long as they are designed for the same TV system. There are two types of laser discs, depending on the way the signals are recorded: standard discs (CAV) (*2) and extended-play discs (CLV) (*3).

Standard Discs (CAV discs) (*2)

These discs include the words "Standard Disc/CAV" or "Standard play" on the jacket or label. They include one picture per revolution and play at a constant speed of 1800 rpm (CAV = Constant Angular Velocity). They offer special playback features such as still frame playback or multi-speed playback. The maximum playing time is 30 minutes per side (for 30cm discs), with a maximum of 54,000 frames, each frame including a frame number between 1 and 54,000.

- The playing time depends on the contents of the disc.

Extended-play Discs (CLV discs) (*3)

These discs include the words "Extended-play Disc/CAV" or "Extended play" on the jacket or label. The signals are recorded at a constant linear speed (CLV = Constant Linear Velocity), and the playing speed changes gradually from 1800 rpm at the innermost section to 600 rpm at the outermost section. Because of this, they offer a longer playing time than standard discs — a maximum of 60 minutes per side (for 30cm discs). CLV discs include time numbers corresponding to the elapsed time from the beginning of the disc.

- The playing time depends on the contents of the disc.

Laser Discs with Digital Sound (*4)

These discs include one of the marks shown at the right on the jacket or label.

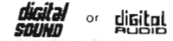

In addition to conventional analog audio signals, these discs also contain digital audio signals. They offer the enjoyment of both the high quality pictures of laser discs plus digital sound. The digital and analog audio signals are recorded on the disc using different frequency bands.

Multi-Audio Laser Discs with Digital and Analog Sound

These discs include one of the marks shown at the right on the jacket or label.

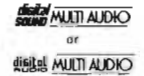

These discs also include both digital and analog audio signals, but the contents of the two are different. You can switch between the digital and analog sound to double your enjoyment.

Compact Discs with Video (CDVs)

These are CDs including a video part. They have a playing time of 25 minutes, 20 minutes containing the same digital audio signals as regular CDs (the audio part), the remaining 5 minutes containing video signals and digital audio signals (the video part). Normally the video part is played first, followed by the audio part.

- Video Singles contain a maximum of 5 minutes of video and digital audio signals.

CD Graphics Discs (CD-Gs) (*5)

CD-Gs contain still pictures and character information in addition to the regular CD audio signals.

6 CONNECTIONS

Using a TV (or projector) with video and audio input jacks

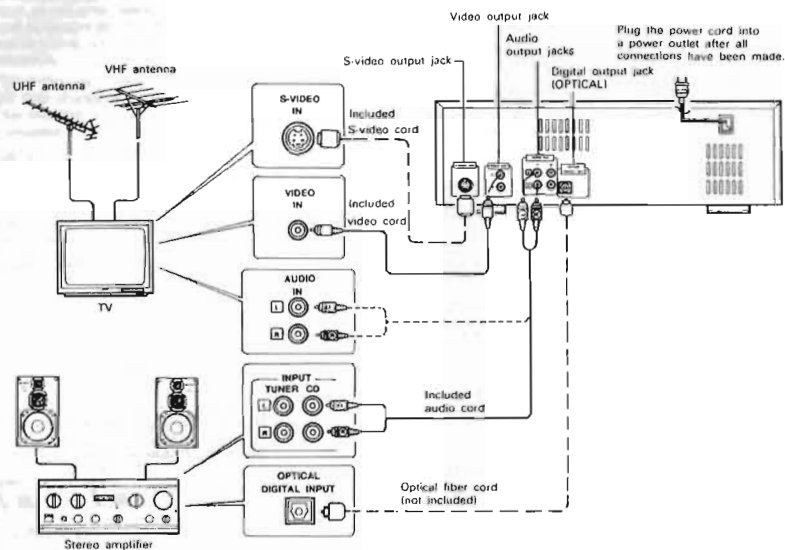

Connections

- ① Connect the LA-3500's VIDEO OUT or S-VIDEO OUT jack to the video or S-video input jack on the TV (or projector). If the TV includes an S-video input jack, we recommend using it for even more vivid pictures.
- ② Connect the LA-3500's AUDIO OUT jacks to the stereo amplifier's AUX or CD input jacks. (NEVER connect them to the PHONO jacks).
 - It is also possible to connect the AUDIO OUT jacks to the TV's audio input jacks and play the sound over the TV's speakers, but we recommend connecting them to a stereo amplifier for better CD and LP sound.
- ③ Connecting the OPTICAL DIGITAL OUT jack
If the stereo amplifier includes a digital input jack (OPTICAL), connect the LA-3500's OPTICAL DIGITAL OUT jack to the amplifier's digital input jack (OPTICAL) using an optical fiber cord, available in stores.

The DIGITAL OUT jack can only be used for connection with an optical transmission/reception module of the same type as the LA-3500. Also use the proper type of optical fiber cord.

NOTE:

This jack is for use exclusively for digital audio signals, and cannot output analog audio signals. The audio channel cannot be switched with the AUDIO MONITOR button.

- ④ Plug the power cord into a power outlet.

- Leave the antennas and video deck already connected to the TV as they are.

NOTE:

The LA-3500 can only be connected to TVs equipped with video input jacks.

Using an AV amplifier

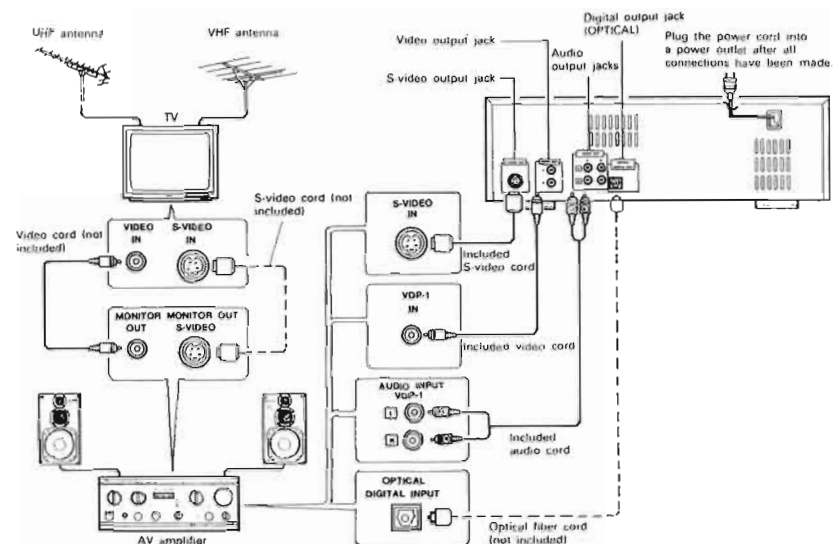

Connecting to the AV amplifier

- ① Connect the LA-3500's VIDEO OUT or S-VIDEO OUT jack to the AV amplifier's input jack.
- ② Connect the LA-3500's AUDIO OUT jacks to the AV amplifier's input jacks.
- ③ Connect the speakers to the AV amplifier's speaker terminals.
- ④ Connecting the OPTICAL DIGITAL OUT jack
Refer to step ③ on Page 10.
- ⑤ Plug the power cord into a power outlet.

7 PART NAMES AND FUNCTIONS

Front Panel

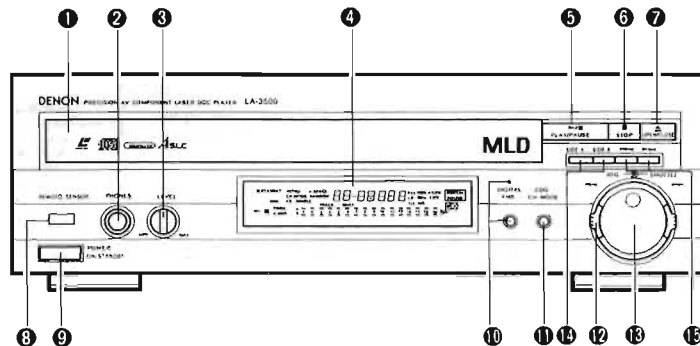

- 1 Door/Disc table**
The disc table opens when the disc table open/close button is pressed. Load the disc in the table.
- 2 Headphones jack (PHONES)**
Use this jack to listen to the sound over headphones (Headphones are sold separately.)
- 3 Headphones volume control (LEVEL)**
Use this to adjust the volume of the headphones.
- 4 Display window**
This displays the chapter numbers, track numbers, frame numbers, time numbers, etc.
For details, refer to Page 14.
- 5 Play/pause button (▶/||)**
When pressed after a disc is set on the disc table, the disc table is drawn in and playback begins.
When pressed in the stop mode, playback begins.
Also press to begin programmed playback (chapter program play).
The pause mode is set when this button is pressed during playback. Press the button again to resume playback from the point at which the disc stopped.
- 6 Stop button (■)**
Press this button to stop the operation during the play, pause, and still frame play modes, when switching between sides A and B and when searching.
- 7 Disc table open/close button (▲)**
When pressed while the disc table is closed, the disc table opens.
When pressed while the disc table is opened, the disc table closes.
- 8 Remote control sensor**
- 9 Power button (POWER)**
Press this to turn the power on and off.
If pressed during playback or other operations, the power does not turn off immediately. "OFF" first appears on the display, then "STANDBY" appears and the power turns off.
Caution:
Whenever the power switch is in the OFF state, the apparatus is still connected on AC line voltage.
Please be sure to unplug the cord when you leave home for, say, a vacation.
- 10 Digital FNR (Field Noise Reduction) button/indicator (DIGITAL FNR)**
Use this to select the digital FNR mode. The digital FNR system is on when the indicator is lit.
For details, refer to Page 33.

- 11 CD-G channel mode selector button (CDG CH MODE)**
Use this to select the CD-G graphics channel. When pressed, the selection mode is set. Select the graphics channel with the skip buttons (◀◀ and ▶▶), then press the CD-G CH MODE selector button to set the selected channel. Press the button again to cancel the selection mode.
For details, refer to Page 28.
- 12 Shuttle ring (SHUTTLE)**
Turn the ring clockwise for slow or fast scanning in the forward direction, counterclockwise for slow or fast scanning in the reverse direction. When turned during playback, the disc is scanned quickly in the forward or reverse direction. Slow and fast forward and reverse scanning are only possible during the pause and still frame modes with LDs and the video part of CDVs. Fast forward and reverse scanning is not possible when playing CD Gs.
For details, refer to Page 24.
- 13 Side A/B buttons (SIDE A/B)**
Use these to select the side of the LD to be played.
For details, refer to Page 23.
- 14 Jog dial (JOG)**
During the play or still frame modes with LDs and the video part of CDVs, turn the dial clockwise to move step-by-step in the forward direction, counterclockwise to move step-by-step in the reverse direction. When turned during playback, the still frame mode is set.
For details, refer to Page 24.
- 15 Skip buttons (◀◀, ▶▶)**
Press these during playback to skip to the beginning of the chapter/track corresponding to the number of times the button is pressed. Press the ◀◀ button to skip backwards, the ▶▶ button to skip forwards. These buttons function as channel selector buttons when the CD-G CH MODE selector button is pressed and the CD-G graphics channel selection mode is set.
For details, refer to Page 25.

Rear Panel

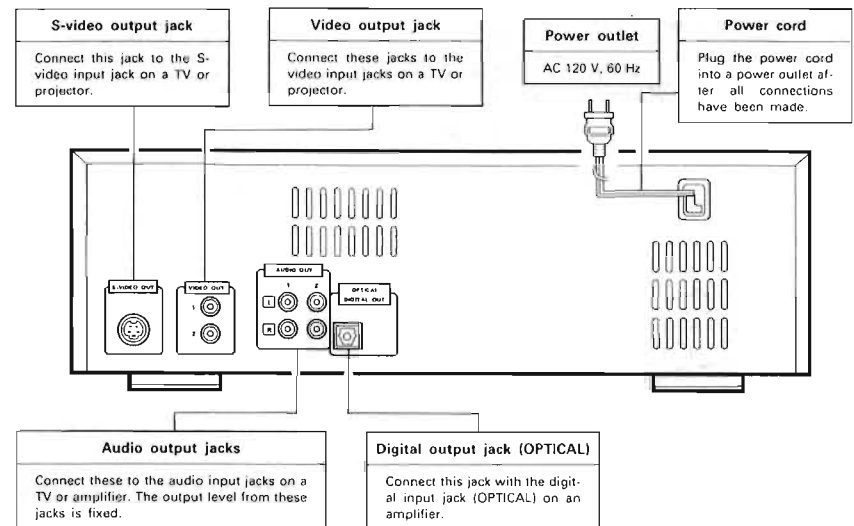

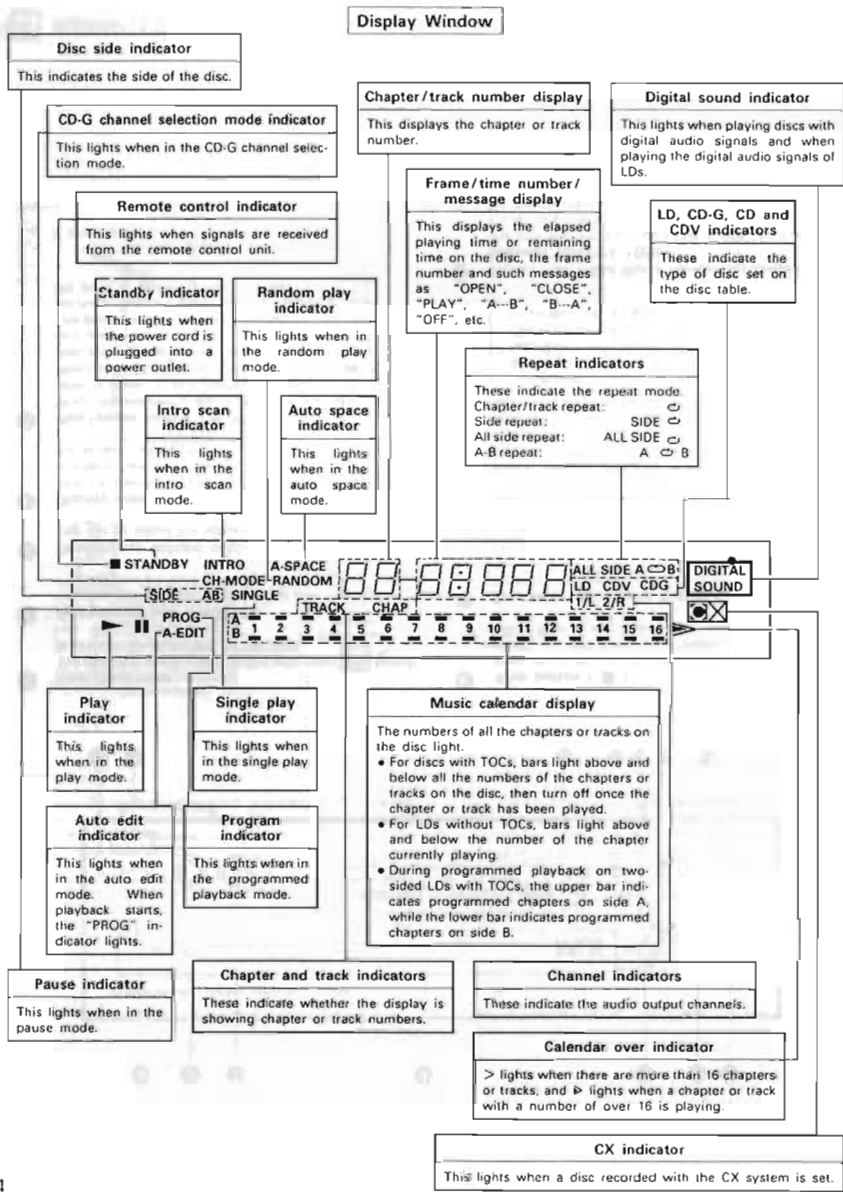

8 OPENING AND CLOSING THE DISC TABLE AND LOADING DISCS

- Opening and Closing the Disc Table**
 (The disc table will not open or close when the power is off.)
- 1 Press the POWER button to turn the power on.
 - 2 Press the open/close button to open the disc table.

Setting Discs

- Set the disc with the label for the side to be played facing up.
- Disc size

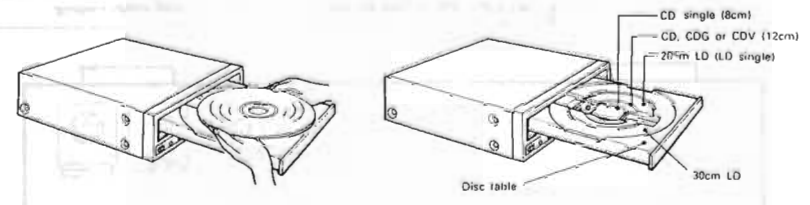

Set the disc properly in the position shown on the above diagram. The disc will not play if it is not properly set.

Notes on Setting Discs

- Only one disc can be set at a time. Setting two discs in the disc table can result in damage or scratch the discs.
- Set 8cm CD singles directly in the disc table without using an adaptor. Be sure to set them securely in the disc guide. If not, the disc may move out of place and the disc table may no longer open.
- Be careful not to touch the signal surface (the side which shines in rainbow colors).
- Be sure to set CDs, CDVs, CD-Gs and LD singles (20cm) with the labelled side facing up.
- For single-sided LDs, be sure to place the side on which the chapter names are written facing up.
- Set LD singles (20cm) directly in the disc table without using an adaptor.

Notes on the Disc Table

- Use the button on the main unit or the remote control unit to open and close the disc table.
- Do not move the unit during playback. Doing so can scratch the disc.
- Do not move the unit while a disc is loaded.
- Applying force to the disc table or placing heavy objects on it can result in damage.
- Be careful not to get your fingers caught in the disc table when it is drawn in.

The following can result in damage:

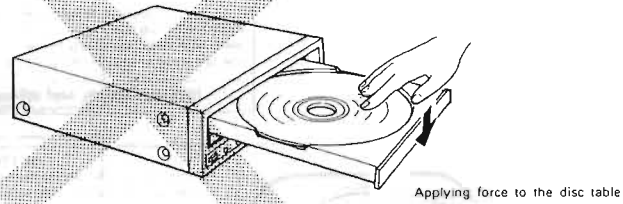

Applying force to the disc table

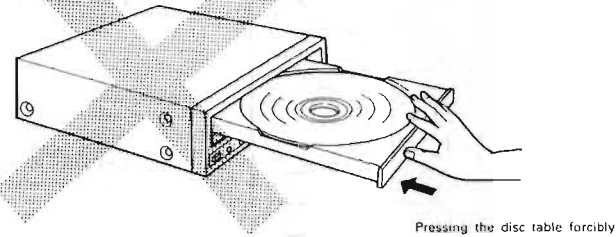

Pressing the disc table forcibly

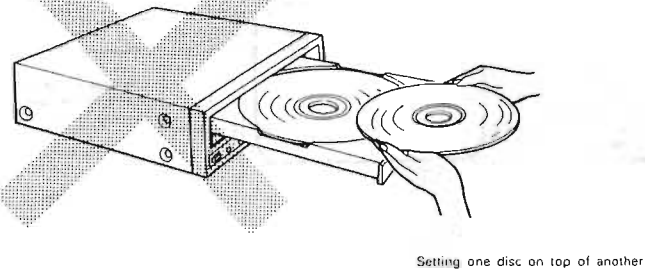

Setting one disc on top of another

9 REMOTE CONTROL UNIT

• Inserting Batteries

NOTES:

- Use R6P (AA) batteries in this remote control unit.
- Replace the batteries after approximately one year, though this depends on the frequency with which the remote control unit is used.
- If, even before one year is up, the LA-3500 does not operate when the remote control unit is operated close to it, replace the batteries with new ones.
- Be sure to insert the batteries in the proper direction, following the "+" and "-" marks on the battery compartment.
- Remove the batteries when you do not plan to use the remote control unit for an extended period of time.
- To prevent damage and leakage:
 - Never mix old batteries with new ones.
 - Never use different types of batteries together.
 - Do not short-circuit, take apart, heat, or dispose of batteries in flames.
- If the batteries should leak, carefully wipe off the battery fluid from the battery compartment and insert new batteries.

① Remove the rear lid of the remote control unit.

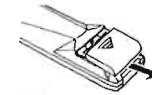

② Insert two R6P (AA) batteries into the battery compartment, following the "+" and "-" marks.

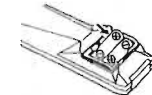

③ Set the rear lid back in place.

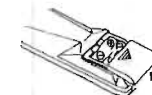

Using the remote control unit

NOTE:

- The remote control unit may not operate properly if the remote control sensor is exposed to direct sunlight or strong lighting, or if there is an obstacle between the remote control unit and the remote control sensor.
- Do not press buttons on the main unit and the remote control unit simultaneously. Doing so may result in malfunction.

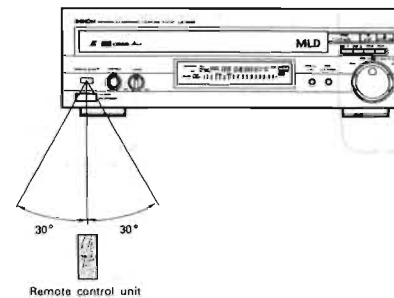

Point the remote control unit at the remote control sensor when operating it, as shown on the diagram. The remote control unit will operate within a direct distance of approximately 6 meters. This distance will be shortened if obstacles are present or if operated from an angle. The remote control unit can be operated within an angle of 30° to either side of the remote control sensor.

Remote Control Unit Part Names and Functions

Buttons not explained on this page operate in the same way as the corresponding buttons on the player. Refer to the section on the front panel (Pages 12 and 13).
 Buttons marked in this way have functions which are only operable from the remote control unit.

Power button (POWER)

Program button (PROGRAM)
 Use this to select the program input mode. (See Page 34.)

Search mode button (SEARCH MODE)
 Use this to find specific sections on LDs. (See Page 27.)

Call button (CALL)
 Use this when changing program settings. (See Page 35.)

Auto space button (AUTO SPACE)
 This inserts blank spaces of approximately 4 seconds between chapters or tracks. (See Page 32.)

Digital/analog/CX button (DIGITAL/ANALOG/CX)
 Use this to select the audio signals (digital or analog) to be output when playing laser discs including digital audio signals.
 Use this when the CX noise reduction system does not turn on automatically when playing the analog audio signals. (See Page 38.)

Single play button (SINGLE)
 When pressed, the single play mode is set, and the disc is set to the pause mode after each chapter/track is played. Press this button again to cancel the single stop mode. (See Page 29.)

Side A/B buttons (SIDE A and SIDE B)

Open/close button (OPEN/CLOSE ▲)

Number buttons (0 to 9 and +10)
 Use these for selecting chapters and tracks, inputting frame and time numbers, etc.

Clear button (CLEAR)
 Use this button in the following cases:
 • To correct numbers input with the number buttons.
 • To return to the previous step when inputting or changing programs.

Skip buttons (◀◀ and ▶▶)

Play/pause button (PLAY ▶ / II PAUSE)

Stop button (■ STOP)

Fast forward and reverse scan buttons (◀◀ and ▶▶)
 Use these for fast forward or fast reverse scanning.
 • These buttons do not function when playing CD-Gs. (See Page 25.)

Shuttle ring

Jog dial

Random play button (RANDOM)
 Use this for random playback. (See Page 31.)

Auto edit button (AUTO EDIT)
 Use this for editing according to the length of the tape. (See Page 31.)

Fluorescent display dimmer button (FL DIMMER)
 Use this to switch the brightness of the display window. (See Page 33.)

Intro scan button (INTRO SCAN)
 Use this to play the beginning (approximately 8 seconds) of the chapters or tracks. (See Page 27.)

Audio monitor button (AUDIO MONITOR)
 Use this to switch the audio channel. The stereo mode (STEREO) is set when the power is turned on. The channel switches as follows each time the button is pressed: 1/L → 2/R → STEREO → 1/L ... (See Page 38.)

Strobe play button (STROBE)
 Use this for strobe playback. Use the + and - buttons to set the speed. (See Page 32.)

Still & sound play button (STILL & SOUND)
 When this button is pressed, the picture stops and a still frame is displayed but the sound is played normally. (See Page 33.)

Repeat and A-B repeat buttons (REPEAT and A-B)
 Use these to play discs repeatedly. (See Page 36.)

Art button (ART)
 Use this to achieve a special painting-like effect on the picture. (See Page 33.)

Digital FNR (Field Noise Reduction) button (DIGITAL FNR)

On-screen display button (ON SCREEN)
 Use this to turn the display on the TV screen on and off and to switch the items displayed. (See Page 20.)

Still/step buttons (◀II and II▶)
 The still frame mode is set when either of these buttons is pressed while playing an LD or the video part of a CDV. Next, press the II▶ button to move step-by-step forward, the ◀II button to move step-by-step backward. (See Page 30.)

Multi-speed buttons (MULTI SPEED ◀ and ▶)
 When playing an LD or the video part of a CDV: Press the ▶ button to play the disc forward at the preset speed, the ◀ button to play the disc backward. No sound is produced, except when playing forward at a speed of "x.1". Use the + and - buttons to set the speed. (See Page 30.)

Speed setting buttons (+ and -)
 Use these buttons to set the speed for multi-speed and strobe playback. Unless the STROBE button has been pressed, these buttons set the speed for multi-speed playback. (See Pages 30 and 32.)

10 ON-SCREEN DISPLAY

(1) Examples of On-screen Displays

There are many other on-screen displays as well. (These are described in the text.)

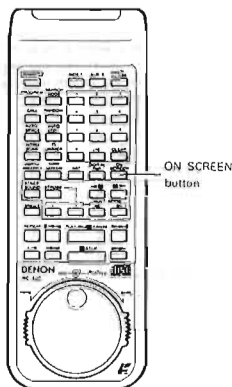
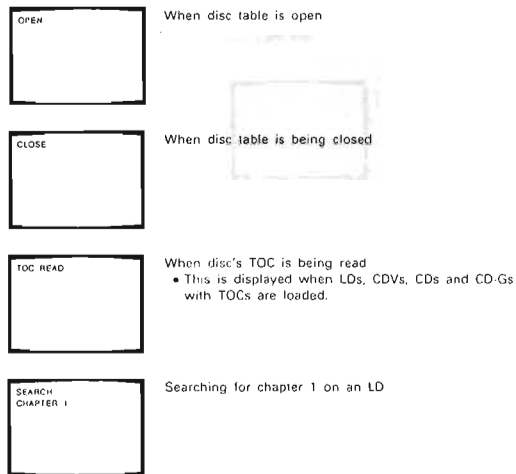

- The screen turns blue when the disc table is opened and closed and when in the stop and pause modes, as well as during the play and search modes on CDs and the audio parts of CDVs and during the search mode on CD-Gs.
- The screen turns black when automatically changing from side A to side B of an LD.

(2) Displays in the Stop Mode

In the stop mode, the total number of chapters/tracks on the disc, the total playing time, the type of disc, etc., are displayed. The music calendar is only displayed for CDs, CDVs and CD-Gs.

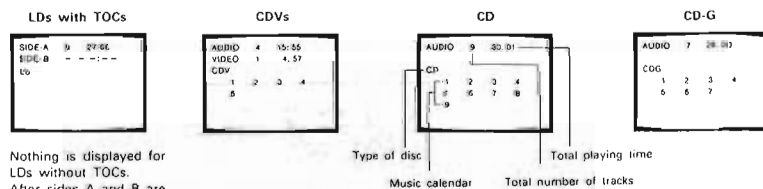

Nothing is displayed for LDs without TOCs. After sides A and B are played, the total number of chapters and total playing time are displayed for both sides A and B.

(3) Checking During Playback

The display changes as shown below each time the ON SCREEN button on the remote control unit is pressed. The items displayed differ according to the type of disc.

■ For LDs

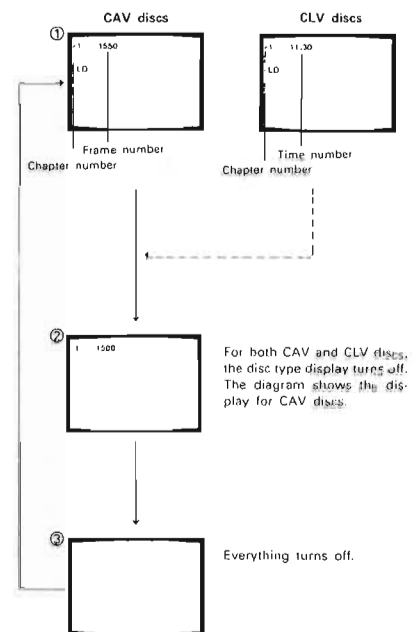

■ For CDs, CDVs and CD-Gs

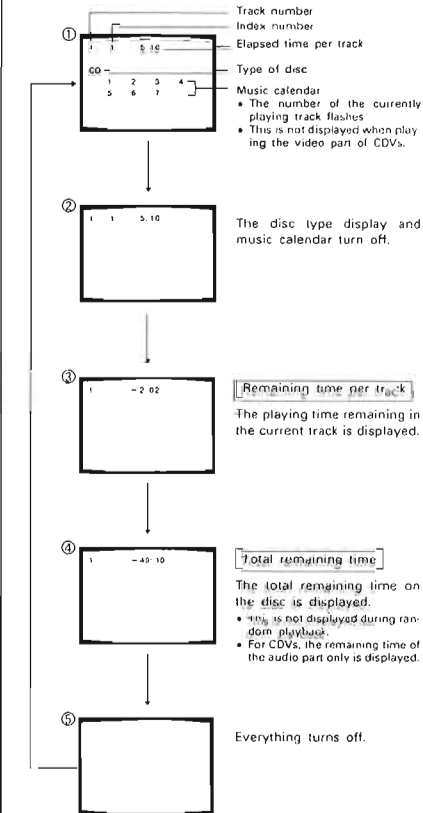

NOTES:

- The chapter number is not displayed for discs on which the chapters are not recorded.
- Only the minutes are displayed for CLV discs on which the seconds are not recorded.

NOTES:

- When the auto space function is used to insert 4-second blank spaces between tracks, this time is not included in the remaining time display.
- In some cases, the remaining time display may not reach "00" even when the disc is played to the end.

11 REGULAR PLAYBACK

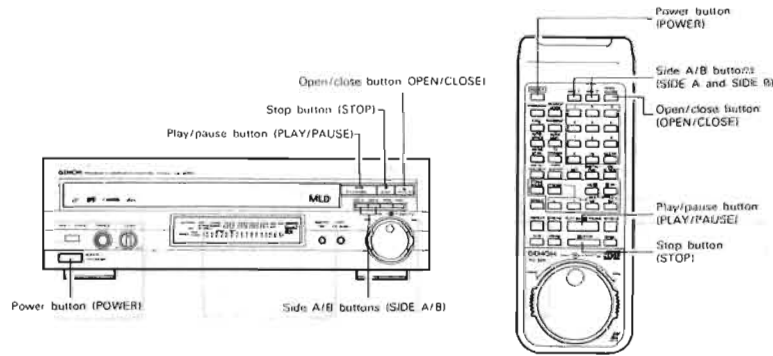

(1) Basic Operation

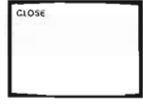
- 1 Press the POWER button.
- 2 Press the open/close button. 
- 3 Set the disc on the disc table. Be sure the disc is set in the proper disc guide.
- 4 Press the play/pause button. 

• For CDVs, playback starts from the video part.

To stop playback temporarily:

Press the play/pause button. Press the play/pause button again to resume playback.



To cancel playback:

Press the stop button.

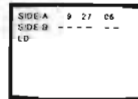

For LDs

NOTES:

- Do not open the disc table door by hand.
- Use the button on the main unit or the remote control unit to open and close the disc table.
- Do not push on the disc table to close it. Doing so may damage it.

(2) Playing Two-sided Discs (LDs)

To watch side A:

- Press the play/pause button.
- "SIDE A" appears on the display window.
- Playback of side B begins automatically once side A is played. The screen turns black while the disc is switched from side A to side B.



To watch side B:

- Press the SIDE B button.
- "A-B" and "SIDE B" appear on the display window.
- Once the end of side A is reached or if playback is stopped in the middle of side B, the pickup returns to side A and the stop mode is set.



Switching to the other side in the middle of the disc

Press the SIDE B button to switch from side A to side B. Press the SIDE A button to switch from side B to side A.

Playing side B directly when the disc table is open

- 1 Press the open/close button.
- 2 Press the SIDE B button after "PLAY" appears on the display window.

NOTES:

- Side A refers to the side facing up when the LD is set on the disc table, side B to the side facing down. Depending on how the disc is set, side A may not correspond to the A side indicated on the disc.
- If the button for the opposite side is pressed in the pause mode, the pause mode is cancelled. To set the pause mode, press the play/pause button after pressing the side button.



(3) Last Memory Function (LDs)

- For LDs only, the position at which playback is stopped is stored in the memory, so when the play button is pressed again while in the stop mode, playback begins from a point just before the position at which playback was stopped.
- The last memory function does not work during programmed playback, random playback, auto edit playback and repeat playback.



For CAV LDs

(4) After Playing a Disc

- 1 Press the open/close button. 
- 2 Remove the disc from the disc table.
- 3 Press the open/close button. 
- 4 Press the POWER button.

NOTES:

- Do not leave the disc table open.
- Do not turn off the power with the disc table.
- Be sure to remove the disc from the player and store it vertically in its jacket or case.

12 FINDING SPECIFIC SECTIONS

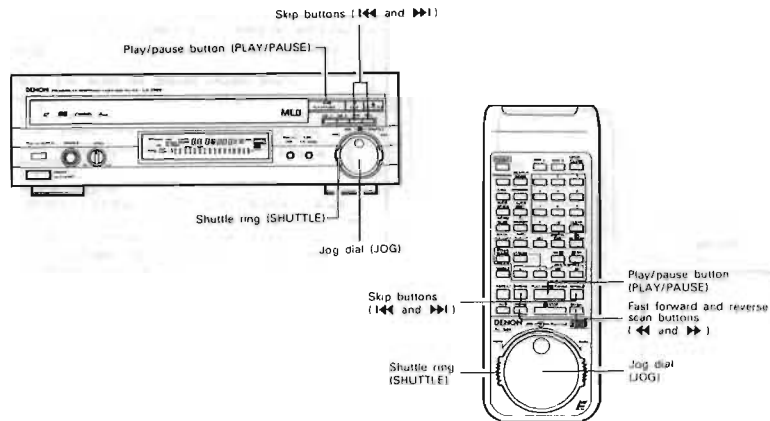

(1) Jog Dial (LDs, CDs and CDVs)

Use the JOG dial to watch the pictures one frame at a time (for LDs and the video part of CDVs) or to find the beginning of chapters or tracks with greater precision.



Turn the JOG dial during playback.

- The still frame mode is set when the dial is turned during playback. (For CDs and the audio part of CDVs, the sound is paused.)
- Turn the dial clockwise to move in the forward direction, counterclockwise to move in the reverse direction.
- When the dial is turned slowly, the picture moves one frame at a time, and when turned approximately 5 times per second, the picture moves (in the forward or reverse direction) at the same speed as during regular playback.

NOTE:
The JOG dial does not function when playing CD-Gs.

■ To return to normal playback:

Press the play/pause button.

■ On-screen display

CLV LDs and the video part of CDVs do not have numbers for individual frames (frame numbers), as do CAV LDs.

The LA-3500 divides each second of CLV LDs and the video part of CDVs into 30 frames so that still frame and step-by-step playback are possible. When the JOG dial is turned with CLV LDs, a number from "00" to "29" is displayed after the minutes and seconds (when the ON SCREEN button is pressed).

- This is not displayed for the video part of CDVs.

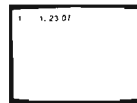

CLV LDs

(2) Shuttle Ring (LDs, CDs and CDVs)

Slow or fast forward or reverse scanning can be selected at will simply by turning the SHUTTLE ring.

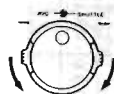

Turn the SHUTTLE ring during playback.

- When released, the SHUTTLE ring returns to the center position.

■ For LDs and video part of CDVs

The operation differs depending on whether the SHUTTLE ring is turned during playback or during the pause or still frame mode.

• During playback

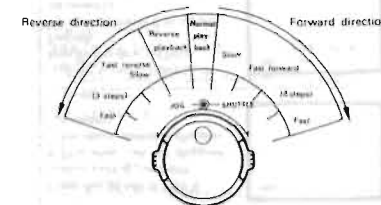

Sound is only produced during normal playback.

• In the pause or still frame mode:

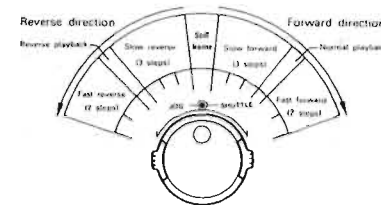

NOTE:
No sound is produced, even at the normal playback position.

■ For CDs and the audio part of CDVs

When turned during playback, the play mode is set when the SHUTTLE ring is returned to the center position. When turned during the pause mode, the pause mode is set when the SHUTTLE ring is returned to the center position.

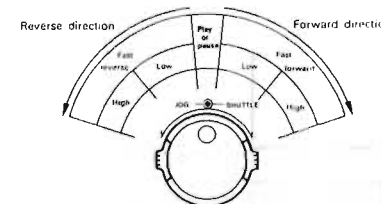

No sound is produced during the fast forward and reverse scanning operations from the pause mode.

NOTE:
The SHUTTLE ring does not function when playing CD-Gs.

(3) Fast Forward and Fast Reverse (LDs, CDs and CDVs)

The disc is scanned in the forward direction when the fast forward scan button is pressed during playback, in the reverse direction when the fast reverse scan button is pressed.

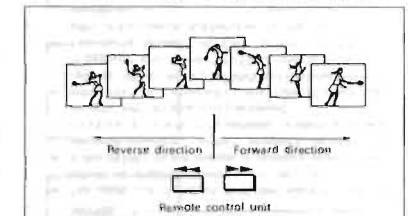

- The disc is scanned at low speed for the first 2.5 seconds after the button is pressed, then at high speed.
- The sound is not produced for LDs and the video part of CDVs. For CDs and the audio part of CDVs, the volume decreases during scanning from the play mode, and only a little sound is produced when scanning from the pause mode.

NOTE:
The fast forward and reverse scanning function does not work when playing CD-Gs.

(4) Finding the Beginning of Chapters or Tracks (Chapter/track skip)

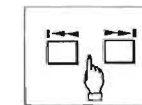

Press one of the skip buttons during playback.

- Press these to skip to the beginning of the chapter/track corresponding to the number of times the button is pressed.

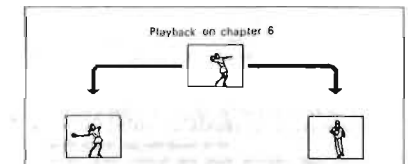

- Remember that when the reverse skip button is pressed, the chapter/track currently playing is counted as one.

NOTE:
When skipping on LDs without TOCs, if you skip to a number greater than the number of chapters included on the disc, playback begins from a point just before the end of the disc.

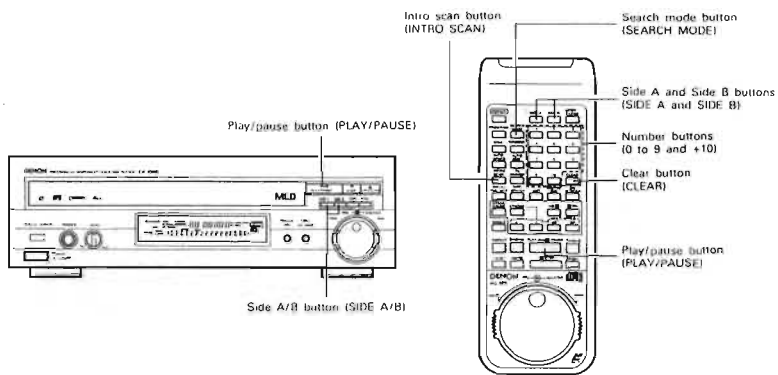

(5) Selecting a Specific Chapter or Track Directly (Chapter/track search)

Press the number button corresponding to the desired chapter/track.

For chapter 3

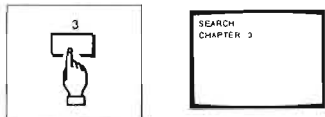

- If the above is not displayed on the screen for LDs, first press the SEARCH MODE button to display "CHAPTER", then press the desired number button.

- For chapters/tracks with numbers of 10 or greater, use the "+10" and "0" buttons.

Examples:

For chapter/track 10: Press "+10" and "0".
For chapter/track 21: Press "+10" twice then "1".

- To search for a chapter number on side B, first press the SIDE B button, then press the desired number button.

NOTE:

The skip and search functions do not work for discs on which the chapters are not recorded.

NOTE:

- When searching on LDs without TOCs, if you specify a number greater than the number of chapters included on the disc, playback begins from a point just before the end of the disc.
- For discs (LDs, CD-Gs, CDs and CDVs) with TOCs, if a chapter/track number not included on the disc is specified, "ERROR" flashes on the screen for approximately 10 seconds and the search operation is not performed.

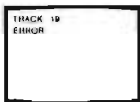

For CDs

(6) Selecting a Specific Section Using the Frame Number Frame Search (CAV LDs)

1	<p>Press the SEARCH MODE button during playback.</p> <ul style="list-style-type: none"> • This step can be skipped for discs without chapter numbers. 	
2	<p>Use the number buttons to specify the number of the desired frame.</p> <p>For frame number 102: Press "1", then "0", then "2".</p> <ul style="list-style-type: none"> • If you press the wrong number, press the CLEAR button then press the right number. 	
3	<p>Press the play/pause button.</p> <ul style="list-style-type: none"> • If this is done in the still frame mode, the still frame mode is set once the specified frame is found. • To search for another frame from this point, just press the number buttons. 	<p>For frame number 102</p>

- The search mode switches as follows each time the SEARCH MODE button is pressed:



NOTES:

- For two-sided discs, to specify a frame number on the side opposite the one currently playing, first press the SIDE A or SIDE B button (the button for the opposite side), then specify the frame number after playback begins on the opposite side.
- If a frame number not recorded on the disc is specified, playback begins from a point just before the end of the disc.

(7) Selecting a Specific Section Using the Time Number Time Search (CLV LDs)

1	<p>Press the SEARCH MODE button during playback.</p> <ul style="list-style-type: none"> • This step can be skipped for discs without chapter numbers. 	
2	<p>Use the number buttons to specify the desired time number.</p> <p>For time number 9 minutes, 10 seconds: Press "9", then "1", then "0".</p> <ul style="list-style-type: none"> • If you press the wrong number, press the CLEAR button then press the right number. 	

3

Press the play/pause button.

- To search for another time number from this point, just press the number buttons.

NOTES:

- For discs on which the time numbers are only in units of minutes, playback will begin from the beginning of the specified minute, even if the seconds are specified.
- For two-sided discs, to specify a time number on the side opposite the one currently playing, first press the SIDE A or SIDE B button (the button for the opposite side), then specify the time number after playback begins on the opposite side.
- If a time number not included on the disc is specified, playback begins from a point just before the end of the disc.

- The search mode switches as follows each time the SEARCH MODE button is pressed:



(8) Looking for a Specific Chapter or Track Intro Scan

When the INTRO SCAN button is pressed, the first 8 seconds (approximately) of each chapter/track is played.

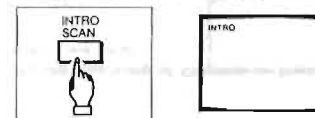

- For two-sided LDs, intro scan begins from side A.
- Once the beginnings of all chapters/tracks have been played, normal playback resumes from the first chapter/track. For LD singles only, the stop mode is set once the beginnings of all chapters have been played.

■ Cancelling Intro Scan

Press the play/pause button.
Normal playback resumes from that point.

NOTES:

- The intro scan function does not work for LDs on which no chapter numbers are recorded.
- If the INTRO SCAN button is pressed during programmed playback, random playback, or auto edit playback, programmed playback, random playback, or auto edit playback is cancelled.
- Intro scan is cancelled if the fast forward, fast reverse, RANDOM, AUTO EDIT or PROGRAM button is pressed and if the SHUTTLE ring is turned.
- The AUTO SPACE, REPEAT, SEARCH MODE and SINGLE buttons do not function during the intro scan operation.

13 OTHER PLAYBACK MODES

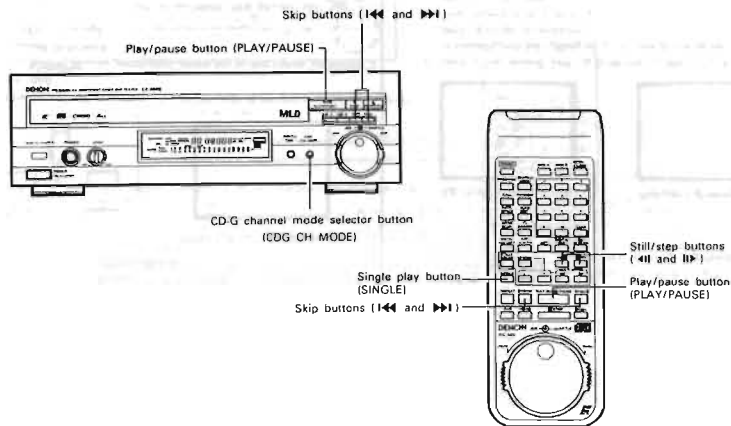

(1) Changing the CD-G Graphics Channel (CD-Gs)

CD-Gs include 16 graphics channels, from 0 to 15. The data output to the screen (the picture) can be selected by selecting the graphics channel. (The number of channels containing data differs from disc to disc.)

- The graphics channel is set to 0 or 1 when the power is turned on.
- Only change the graphics channel if there are instructions on the disc's jacket or in the picture itself. Do not change the graphics channel unless so instructed. If this is done, the proper graphics will not be displayed.

1	<p>Press the CDG CH MODE button.</p> <ul style="list-style-type: none"> • The graphics channel selection mode is set. 	
2	<p>Press the skip button.</p> <ul style="list-style-type: none"> • The channel changes by a number corresponding to the number of times the button is pressed. <p style="text-align: center;">Lower channel Higher channel</p> <p style="text-align: center;">Example: To select channel 7, press the forward skip button (▶) 5 times. • "07" flashes.</p>	

3	<p>Press the CD-G CH MODE button. Channel 7 is selected.</p> <ul style="list-style-type: none"> • To select another channel from this point, repeat from step 2. • To cancel the channel selection mode, proceed to step 6. 	
4	<p>Clearing a channel</p> <p>Press the skip button to set the channel to be cleared.</p> <p>Example:</p> <ul style="list-style-type: none"> • To clear channel 1, press the reverse skip button (◀) 6 times. • "01" flashes. 	
5	<p>Press the CD-G CH MODE button. Channel 1 is cleared.</p>	
<p>To return to the normal mode, press the CDG CH MODE button again.</p>		

■ Returning to the normal mode without adding or clearing graphics channels (after checking the graphics channels)

Press the CD-G CH MODE button again.

NOTE:

LDGs (LDs with the same graphics functions as CD-Gs) can be played as normal LDs on the LA-3500G, but their graphics functions will not work.

(2) Setting the Single Play Mode

Use this for example for karaoke. In the single play mode, the disc is set to the pause mode after each chapter/track is played.

1	<p>Press the SINGLE button.</p> <ul style="list-style-type: none"> • "SINGLE" appears on the main unit's display window. 	
2	<p>Select the chapter/track.</p> <ul style="list-style-type: none"> • Use the number buttons. 	

- The stop mode is set automatically 4 minutes after the disc is set to the pause mode.

■ Cancelling the pause mode

Press the play/pause button to resume normal playback.

■ Cancelling the single stop mode

Press the SINGLE button again.

NOTES:

- The single play function does not work during the A-B repeat mode.
- If you move out of the current chapter/track using the SHUTTLE ring or the scan buttons while in the single stop mode, the pause mode is set at the point where scanning stops.

(3) Playing a Still Frame (LDs and CDVs (video part))

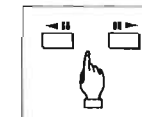

Press one of the still/step buttons during playback.

- The still frame mode is set regardless of which button is pressed.

■ Resuming normal playback

Press the play/pause button.

NOTE:

When playing discs containing special automatic picture stop codes, the still frame mode is set automatically at the frame specified with this code.

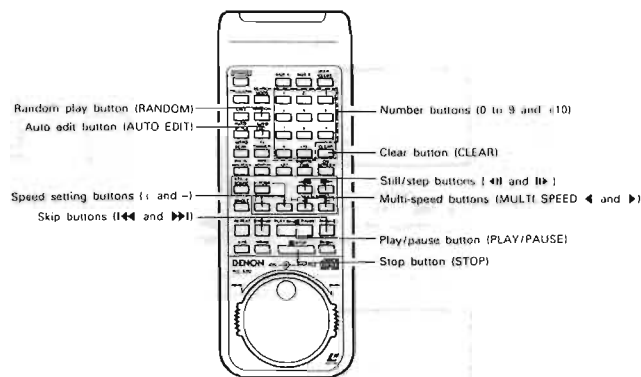

(4) Changing the Frame Step-by-Step (LDs and CDVs (video part))

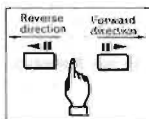

Press one of the still/step buttons during playback.

- The picture moves one frame forward (or backward) each time the button is pressed.

- If pressed for over 2 seconds, the picture automatically moves forward (backward) step-by-step.

Resuming normal playback

Press the play/pause button.

(5) Multi-speed Playback (LDs and CDVs (video part))

- Press the speed setting buttons (+ and -) during playback to change the speed of playback.

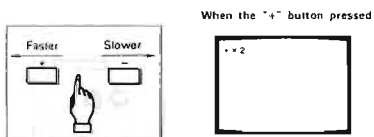

When the "+" button pressed

- The speed of playback changes each time the button is pressed.
- The sound is only produced when set to the same speed as regular playback.

NOTE:

When the STROBE button is pressed, the speed setting buttons (+ and -) change the speed of the strobe effect.

On-screen display	Speed of playback
x3	3 times normal speed
x2	2 times normal speed
x1	Same speed as normal speed
1/2	1/2 normal speed
1/4	1/4 normal speed
1/8	1/8 normal speed
1/16	1/16 normal speed
1/30	1 frame per second
1/60	1 frame every 2 seconds
1/90	1 frame every 3 seconds

To change the direction of playback:

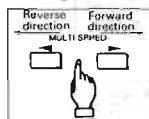

Press the MULTI SPEED ◀ or ▶ button during playback

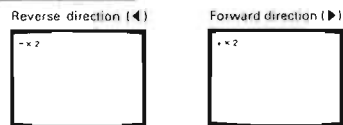

- Using the speed setting buttons in step ①, the speed of playback can be changed in 10 steps for both the forward and reverse directions.
- The sound is only produced when set to the same speed as regular playback.

Resuming normal playback

Press the play/pause button.

(6) Random Playback

Press the RANDOM button in the play or stop mode. The chapters/tracks are automatically played in random order.

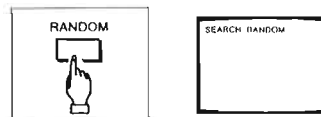

- Once all the chapters/tracks are played, the stop mode is set and the random mode is cancelled.
- For two-sided LDs, the random play function only works for one side. To play the chapters on side B in random order, first set to the playback mode on side B, then press the RANDOM button.

Resuming normal playback

Press the RANDOM button again.

NOTES:

- The random play function does not work for LDs without TOCs.
- Chapter number "0" is not played in the random play mode.

(7) Auto Edit Function

When recording onto a cassette tape, the auto edit function can be used to specify the cassette tape's recording time and automatically program the chapters/tracks to be recorded on sides A and B of the tape.

- Press the AUTO EDIT button in the play or stop mode.

 - The number of the 1st chapter/track can be changed with the skip buttons.
 - The pause mode is set if the AUTO EDIT button is pressed in the play mode.
- Use the number buttons to input the length of the tape (the total of sides A and B). For example, for a 46-minute tape: Press "4" then "6".

 - Programming starts automatically once two digits are input.
 - Once programming is completed, the total number of tracks and total playing time for sides A and B are displayed on the screen, and information for sides A and B is displayed alternately on the main unit's display window.

TAPE		A	B	22:00	AUTO	
		TAPE		B	21:00	EDIT
		PROGRAM				
1	2	3	4			
5	6	7				
8	10					
-	-	-	-			

For CDVs
- Press the play/pause button.

 - The pause mode is set once the chapters/tracks programmed for side A of the tape are played. Press the play/pause button to play the chapters/tracks programmed for side B of the tape.

Clearing steps from the program

Individual steps can be cleared from the program. Press the CALL button repeatedly until the number to be cleared is flashing, then press the CLEAR button.

Adding to the program

Press the number buttons to add to the program. The corresponding chapter/track is added at the end of the program.

Cancelling the auto edit function

Press the AUTO EDIT button again. If the tape time has already been input, set the stop mode and press the STOP button.

Auto editing on side B of a two-sided LD

For two-sided LDs, auto editing only functions for one side at a time. To auto edit on side B, set to the play mode on side B, then press the AUTO EDIT button.

NOTES:

- The auto edit function does not work for LDs without TOCs.
- The maximum tape time which can be input is 99 minutes, the minimum 10 minutes.
- Only 19 chapters/tracks can be edited with the auto edit function, even for discs with 20 or more tracks.
- The auto edit function does not work for discs only containing one chapter/track.
- Chapter number "0" is not programmed.
- Some chapters/tracks will not be programmed if the disc's total playing time is longer than the tape time.
- If the AUTO EDIT button is pressed during intro scan, programmed playback or random playback, intro scan, programmed playback or random playback is cancelled.
- If chapters/tracks are cleared from or added to the program, the total time for sides A and B may no longer match the time first input.

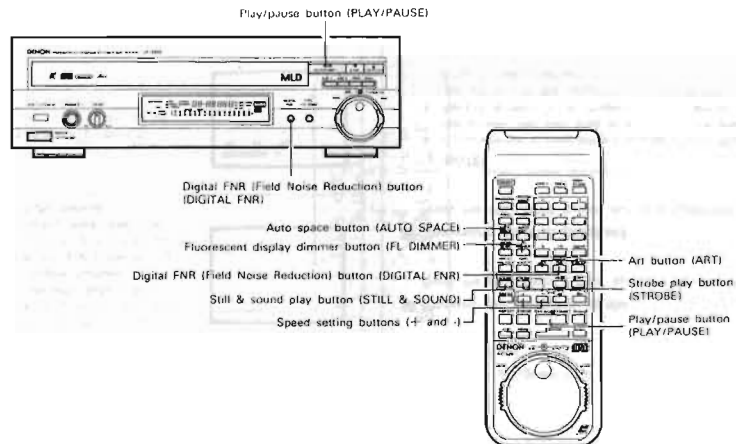

(8) Auto Space Function (CDs, CDVs (audio part) and CD-Gs)

When recording onto a cassette deck, the auto space function can be used to automatically insert the blank sections between selections necessary for automatic searching on the tape. A blank space of about 4 seconds is inserted between selections.

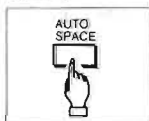

Press the AUTO SPACE button during playback.

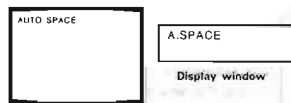

- The pause mode is set for approximately 4 seconds at the end of each track, then playback resumes.

■ Cancelling the auto space function

Press the AUTO SPACE button again.

NOTE:

The auto space function does not work for LDs and the video part of CDVs.

(9) Strobe Playback (LDs and CDVs (video part))

With this function, the sound is played normally, but the picture is a succession of still frames. (Strobe effect)

1 Press the STROBE button during playback.

2 Use the speed setting buttons (+ and -) to set the desired speed.

Display	Speed
1/2	15 frames per second
1/4	About 8 frames per second
1/8	About 4 frames per second
1/16	About 2 frames per second
1/32	1 frame per second
1/60	1 frame every 2 seconds
1/90	1 frame every 3 seconds

■ Resuming normal playback

Press the play/pause button.

- Normal playback also resumes if the SHUTTLE ring is turned.

NOTE:

The speed setting buttons will only change the strobe playback speed after the STROBE button has been pressed. If they are pressed during normal playback without pressing the STROBE button, they change the speed for multi-speed playback.

(10) Still & Sound Playback (LDs and CDVs (video part))

With this function, the sound is played normally, but the picture is stopped.



Press the STILL & SOUND button at the picture you want to stop during playback.

- The picture is still but the sound is played normally.

■ Resuming normal playback

Press the STILL & SOUND button again.

- Normal playback also resumes if the SHUTTLE ring is turned.

NOTE:

This function will only work for the currently playing side of LDs and the video part of CDVs.

(11) Art Playback (LDs and CDVs (video part))

With this function, the picture is processed digitally to create a special painting-like effect.

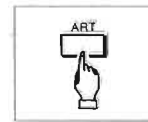

Press the ART button during playback.

- A specially processed picture appears.

■ Changing the strength of the effect

Press the ART button again.

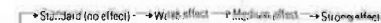

The effect changes each time the ART button is pressed.

- The multi-speed, step-by-step (reverse), still & sound and strobe play functions can also be used during art playback.

NOTE:

The strobe, still & sound and art play modes are only set for one side of the disc. These functions are cancelled if you switch from side A to side B (or vice versa).

(12) Digital FNR (Field Noise Reduction) (LDs and CDVs (video part))

Use this function when there is noise in the picture, for example for movies or live performances. The digital FNR system reduces picture noise and color blotching, making the picture easier to see. Press the DIGITAL FNR button.

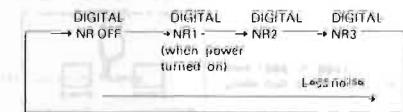
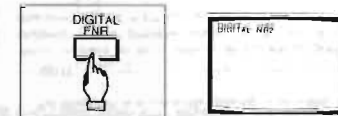

The mode changes each time the button is pressed.

Normally the mode is set to NR1 (standard). If there is a lot of noise in the picture, press the DIGITAL FNR button to set the mode to NR2 or NR3 and improve the picture. If there is little noise, set to the NR OFF mode for an even clearer picture.

- The indicator lights when the digital FNR function is on (NR1, NR2 or NR3).

(13) Fluorescent Display Dimmer Function

The brightness of the display window can be changed in three steps according to the surrounding lighting conditions.



Press the FL DIMMER button.

- The brightness of the display window changes.

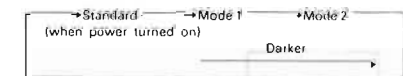

The brightness changes each time the button is pressed.

Normally the brightness is set to the standard (brightest) position. Press the FL DIMMER button to make the display window darker. Mode 2 is the darkest.

14 PROGRAMMED PLAYBACK

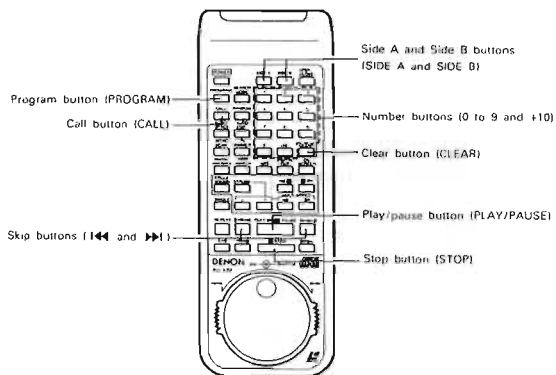

(1) Normal Programmed Playback

With this function, the chapters/tracks on the disc can be programmed to be played in any order. Programming is done in units of chapters or tracks.

Example: Programming chapters 2, 5 and 8 on an LD

1	<p>Press the PROGRAM button in the play or stop mode.</p>	
2	<p>Press number button 3.</p> <ul style="list-style-type: none"> For LDs, the disc side, A or B, is automatically indicated before the chapter number. If you press the wrong number, press the CLEAR button then press the right number. 	
3	<p>Now press 5, then 8.</p> <ul style="list-style-type: none"> Up to 20 steps can be programmed. 	

4

Press the play/pause button.

- "PROG" appears on the main unit's display window and programmed playback begins.
- Once all the programmed chapters/tracks have played, the stop mode is set and the program screen is displayed.

Stopping programmed playback

Press the STOP button.

Playing the program again

Press the play/pause button again.

Resuming normal playback

Press the PROGRAM button during programmed playback.

NOTES:

- If you attempt to program a 21st step, "FULL" flashes on the screen and that step is not set in the program.
- For LDs without TOCs, chapters not included on the disc can be set in the program but are skipped during programmed playback.

(2) Programming Chapters on Both Sides of the Disc (LDs)

Example: Programming chapter 3 on side A, chapter 2 on side B and chapter 5 on side A

1	<p>Press the PROGRAM button in the play or stop mode.</p>	
2	<p>Press the SIDE A button, then press number button 3.</p> <ul style="list-style-type: none"> If you press the wrong number, press the CLEAR button then press the right number. 	
3	<p>Press the SIDE B button, then press number button 2.</p> <ul style="list-style-type: none"> Be sure to press the side button before specifying the chapter number. 	
4	<p>Press the SIDE A button, then press number button 5.</p>	
5	<p>Press the play/pause button.</p> <ul style="list-style-type: none"> Programmed playback begins. Once all the programmed chapters have played, the stop mode is set and the program screen is displayed. 	

NOTES:

- For one-sided LDs, nothing happens if chapters on the non-recorded side of the disc are specified.
- The sides are indicated on the music calendar on the main unit's display window by bars above the numbers for chapter numbers programmed for side A, below the numbers for chapter numbers programmed for B.

(3) Clearing and Adding Steps to the Program and Clearing the Entire Program

Clearing steps from the program

Individual steps can be cleared from the program.

1	<p>Press the CALL button repeatedly until the number to be cleared is flashing.</p>	
<p>Example: To clear chapter number 2 on side B</p>		
2	<p>Press the CLEAR button.</p> <ul style="list-style-type: none"> Chapter number 2 on side B is cleared from the program. 	

NOTE:

The chapter/track currently playing cannot be cleared.

Adding steps to the program

Press the number buttons to add to the program. The corresponding chapter/track is added at the end of the program.

Clearing the entire program

Press the STOP button while in the stop mode.

- The entire program is also cleared when the power is turned off and when the disc table is opened.

(4) Skipping During Programmed Playback

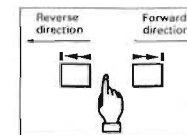

Press one of the SKIP buttons (1 or 2).

- Remember that when the reverse skip button is pressed, the chapter/track currently playing is counted as one.

NOTE:

When chapters on both sides of an LD are programmed, skipping is not possible when "A-B" or "B-A" is displayed on the main unit's display window.

15 REPEAT PLAYBACK

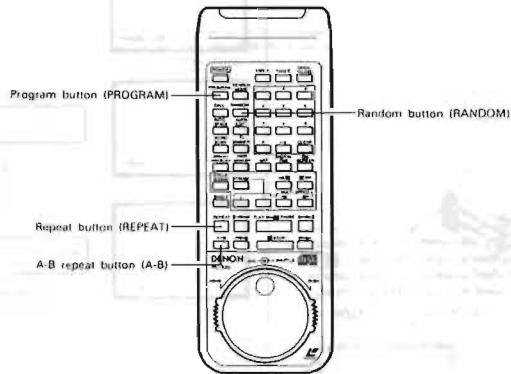

(1) Chapter/Track Repeat, Side Repeat and All Side Repeat

Press the REPEAT button during playback.



- The display changes as shown at the right each time the button is pressed, and the corresponding repeat mode is set. The on-screen display turns off after approximately 5 seconds.

■ Playing the current chapter repeatedly Chapter Repeat (LDs)

■ Playing the current track repeatedly Track Repeat (CDs, CDVs and CD-Gs)

■ Playing the current side repeatedly Side Repeat (LDs, CDs, CDVs and CD-Gs)

■ Playing both sides of the disc repeatedly All Side Repeat (LDs)

This only works for two-sided LDs.

NOTE:

For LDs on which the chapter numbers are not recorded, the side repeat mode is set when the REPEAT button is pressed. The chapter repeat mode cannot be set.

■ LDs

- Chapter repeat



- Side repeat



- All side repeat



(Two-sided LDs only)

- Repeat off

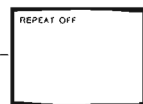

■ CD-Gs, CDs and CDVs

- Track repeat



- Side repeat



- Repeat off



(2) A-B Repeat (LDs, CDs and CDVs)

- With this function, a section between two specified points can be played repeatedly.

1	<p>During playback, press the A-B button at the point from which you want to start repeating.</p> <ul style="list-style-type: none"> • Repeat start point A is stored in the memory. 	
2	<p>Press the A-B button at the point at which you want to end repeating.</p> <ul style="list-style-type: none"> • A-B repeat starts. 	

■ Cancelling A-B repeat

Press the A-B button to display "A-B OFF".

- A-B repeat is also cancelled when the STOP or open/close button is pressed.



NOTES:

- For CDVs, A-B repeat is not possible if point A is in the video part, point B in the audio part.
- For LDs, A-B repeat is not possible if points A and B are on different sides of the disc.
- For CLV LDs on which the seconds are not recorded, A-B repeat is only possible in units of minutes.
- A-B repeat is not possible during random and programmed playback.
- If the A-B repeat mode is set during chapter/track repeat, side repeat or all side repeat, the previous repeat mode is cancelled and A-B repeat is set.
- The A-B repeat function does not work for CD-Gs.

(3) Program Repeat

Press the REPEAT button during programmed playback

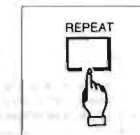

- For instructions on programmed playback, see Page 34.

■ Cancelling program repeat

Press the PROGRAM button.

(4) Random Repeat

Press the RANDOM button.

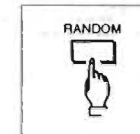

Press the REPEAT button.

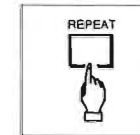

■ Cancelling random repeat

Press the RANDOM button.

NOTES:

- Random repeat is not possible on LDs without TOCs.
- If the RANDOM button is pressed during intro scan, programmed playback or auto edited playback, intro scan, programmed playback or auto edited playback is cancelled.

16 SWITCHING THE AUDIO CHANNEL

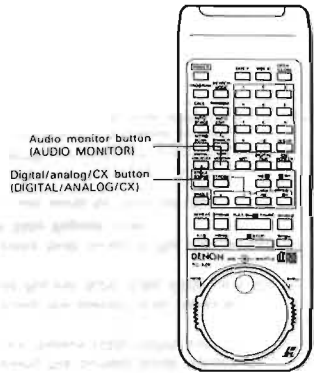

(1) Stereo and Bilingual Discs

Press the AUDIO MONITOR button.
 • The audio mode changes as follows when the AUDIO MONITOR button is pressed.

	Stereo discs	Bilingual discs
When power turned on 1/L 2/R (stereo)	Stereo	Main audio part from left channel Sub audio part from right channel
↓ 1/L	Left channel	Main audio part
↓ 2/R	Right channel	Sub audio part

- Display

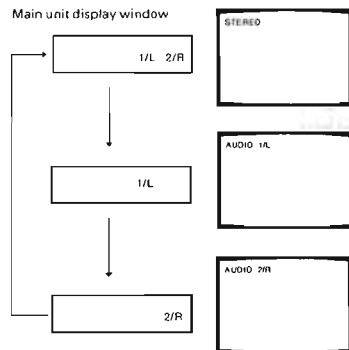

(2) Discs with Digital Sound (LDs)

LDs with digital sound include both analog and digital audio signals. Press the DIGITAL/ANALOG/CX button to switch between the digital and analog sound.

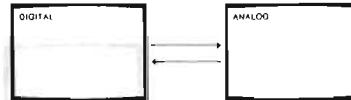

- The **DIGITAL SOUND** indicator on the main unit's display window when the digital signals are selected.
- The digital signals are selected when the power is turned on.

NOTE:
 On some LDs with digital sound, the level of the digital and analog signals is different, so the volume will change when the audio signals are switched.

(3) Discs With the CX Mark (LDs)

For most discs with the mark, the CX noise reduction system is turned on automatically, providing powerful sound with little noise.
 For some discs with the mark, the CX noise reduction system is not turned on automatically. In this case, press the DIGITAL/ANALOG/CX button so that "CX ON" appears on the screen.

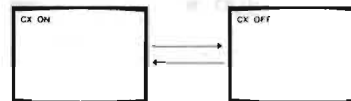

NOTE:
 The sound quality will be poor if the CX noise reduction system is turned on when playing discs with no CX mark.
 is a registered trademark of CBS. The LA-3500 conforms to the expanded CX specifications.



17 TROUBLESHOOTING

Check again before requesting servicing.

- Are all connections proper?
- Is the set being operated according to the operating instructions?

If the set does not seem to be operating properly, check the points on the table below. If none of the items on the table apply, the set may be malfunctioning. Turn off the power immediately and contact your store of purchase.

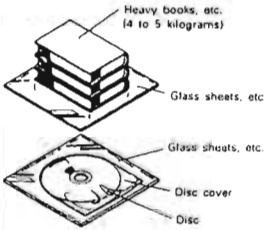
Symptom	Cause	Measures
1. "STANDBY" does not appear when power cord is plugged in.	• Power plug is not plugged in or is not thoroughly inserted.	• Make sure the power plug is plugged in thoroughly.
2. Power turns on by no sound is produced.	• Rear panel connection cords are not properly connected.	• Refer to the manual and connect the cords properly.
3. Disc table does not open.	• Power is not on.	• Plug the power cord into the outlet and press the POWER button to turn on the power.
4. Disc does not play when direct search buttons or play/pause button is pressed.	• Disc is extremely dirty. • Disc is upside down. • Disc is not properly set in disc table. • There is dew in the player.	• Clean the disc. • Use a disc cleaning kit (available in stores). • Set the disc with the labelled side facing up. • Set the disc properly. • Remove the disc and let the player sit for one or two hours with the power on so that the dew evaporates.
5. When switched to the TV, the picture is worse than before the player was connected or there are stripes on the picture.	• Depending on the TV signal reception conditions, stripes may appear when watching the TV while the player is on. This is not a problem with the player.	• Turn the player's power off. • If the problem persists, check the antenna, or use a booster (available in stores).
6. Remote control unit does not work.	• Unit is too far from the player, or is at too strong an angle. • Batteries are worn out. • There is an obstacle between the sensor on the player and the remote control unit.	• Operate the remote control unit from within an angle of about 30° and a distance of about 6 meters. • Replace the batteries if the range from which the remote control unit operates becomes extremely limited. • Replace the batteries. • Replace both batteries with new ones. • Remove the obstacle or move the remote control unit.
7. TV malfunctions when the remote control unit is operated.	• This remote control unit may cause some TVs equipped for wireless remote control to malfunction.	• Move the TV away from the player or cover the TV's remote control sensor when operating the remote control unit.
8. Disc turns but picture does not appear (or picture quality is bad). (Only when playing on a TV)	• TV's (or color monitor's) power is not turned on. • Connections are wrong. • Connection plugs are disconnected (or not fully inserted). • TV's input selector is set to the TV mode.	• Turn on the TV's power. • Connect properly. • Insert securely. • Set the TV's or monitor's input selector to the video input mode when playing discs.
9. Vertical synchronization is off (picture rolls).	• The picture may roll temporarily when the picture switches from a dark scene to a bright scene, but this is not a malfunction.	• Adjust the TV's vertical synchronization.

Symptom	Cause	Measures
10. Picture quality is poor for certain discs.	<ul style="list-style-type: none"> Disc is extremely dirty. Disc is misshapen (warped, etc.). Do not use heavily misshapen discs. (⇒ See Page 7.) 	<ul style="list-style-type: none"> Clean the disc. <ul style="list-style-type: none"> ⇒ Use a disc cleaning kit (available in stores). Flatten the disc. <ul style="list-style-type: none"> ⇒ Set the disc in its cover, place it between two sheets of glass or other flat objects, put a weight of 4 to 5 kilograms on it and leave it like this for one day. This may reduce the warping.  <p>Heavy books, etc. (4 to 5 kilograms)</p> <p>Glass sheets, etc.</p> <p>Glass sheets, etc.</p> <p>Disc cover</p> <p>Disc</p>
11. Sound is muddled.	<ul style="list-style-type: none"> CX system is on though the disc does not include the  mark. 	<ul style="list-style-type: none"> Turn the DIGITAL/ANALOG/CX button on the remote control unit off.
12. No sound is produced.	<ul style="list-style-type: none"> Multi-speed playback mode is set. (Sound is only produced in the normal playback mode.) 	<ul style="list-style-type: none"> Press the play/pause button to return to the normal playback mode.
13. Some still pictures are not still.	<ul style="list-style-type: none"> Even for standard discs, still pictures may not be still during scenes in which movement is intense. 	<ul style="list-style-type: none"> This is not a malfunction of the disc or player.
14. Scanning is not possible on a laser disc.	<ul style="list-style-type: none"> Chapter numbers are not recorded on the disc. 	<ul style="list-style-type: none"> Functions using chapter numbers cannot be used if the chapter numbers are not recorded on the disc.
15. Starting and searching is slow.	<ul style="list-style-type: none"> For some discs, extra time is required for reading the codes. (This is not a malfunction.) Disc is scratched or dirty. (Extremely scratched discs may not play.) 	<ul style="list-style-type: none"> If the disc is scratched, stop using it. If the disc is dirty, clean it. (Refer to Symptom 10.)
16. Some discs require some time before starting or do not start at all.	<ul style="list-style-type: none"> Error in reading subcodes. (This is not a malfunction.) 	<ul style="list-style-type: none"> Press the STOP button to stop the disc, then press the play/pause button again. Repeat this until the disc starts.
17. Time is required to return to point A during A-B repeat.	<ul style="list-style-type: none"> Same as 15 above. 	<ul style="list-style-type: none"> Same as 15 above.
18. Chapter skip, chapter program, and chapter number search operations do not function.	<ul style="list-style-type: none"> Chapter numbers are not recorded on the disc. 	<ul style="list-style-type: none"> Functions using chapter numbers cannot be used if the chapter numbers are not recorded on the disc.
19. Fast forward and reverse scanning is not possible.	<ul style="list-style-type: none"> Disc is a CD-G. 	<ul style="list-style-type: none"> Fast forward and reverse scanning is not possible on CD-Gs.
20. Picture is unstable during fast forward and reverse scanning.	<ul style="list-style-type: none"> This picture may be somewhat unstable, but this is not a malfunction. 	<ul style="list-style-type: none"> —

18 MAIN SPECIFICATIONS

1. General

Type:	Laservision video disc system and compact disc digital audio system
Laser:	Semiconductor laser, 780 nm wavelength
Power supply:	AC 120 V, 60 Hz
Power consumption:	44 W
Weight:	10.6 kg
External dimensions:	434 (W) × 141 (H) × 440 (D) mm
Working temperature range:	+5°C to +35°C
Working humidity range:	5% to 90% (with no condensation)

2. Discs

• Laservision Discs

Playing times for standard (CAV) discs:	30 cm: Max. 1 hour for both sides
	20 cm: Max. 28 min. for both sides
	Max. 14 min. for one side

Playing times for extended-play (CLV) discs:	30 cm: Max. 2 hours for both sides
	20 cm: Max. 40 min. for both sides
	Max. 20 min. for one side

Speed:	30 cm standard discs: 1800 rpm
	30 cm extended-play discs: 1800 rpm to 600 rpm

• Compact discs (CDs and CD-Gs)

Diameter:	12 cm or 8 cm
Direction of rotation (signal side):	Counterclockwise
Linear speed:	1.2 to 1.4 m/sec

• Compact discs with video signals (CDVs)

Diameter:	12 cm
Direction of rotation (signal side):	Counterclockwise
Linear speed:	Audio part: 1.2 ~ 1.4 m/sec
	Video part: 11 ~ 12 m/sec
Max. playing time:	Audio part: 20 min. (digital)
	Video part: 5 min. (CLV)
	The playing time differs from disc to disc.

3. Video outputs (two pin jacks)

Format:	NTSC specification
Output level:	1 Vp-p (with 75 ohm load, sync. negative)

4. S-video output

Output level:	Y output: 1 Vp-p (with 75 ohm load, sync. negative)
	C output: 0.286Vp-p (with 75 ohm load)

5. Audio outputs (two sets)

Output level:	Digital audio output: 200 mVrms (1 kHz, -20dB)
	Analog audio output: 200 mVrms (1 kHz, 40%)
Digital audio performance	Frequency response: 4 Hz ~ 20 kHz
	S/N ratio: 110 dB
	Dynamic range: 100 dB
	Wow and flutter: Below measurable limits (below ±0.001% W. peak)

6. Other output jacks

Optical digital output jack
Headphones output jack

- For improvement purposes, specifications and design are subject to change without notice.

DISASSEMBLY AND ASSEMBLY

Caution: When move or ship the set, be sure to press the power switch, and confirm the display changes from "OFF" to "STANDBY" and then unplug the power cord.

1. Top Cover [Exploded View (1)]

(1) Remove 6 screws (53), a special screw (52), and detach the Top Cover (41)

※ Special screw (52) is warty and different from other screw.
Use care.

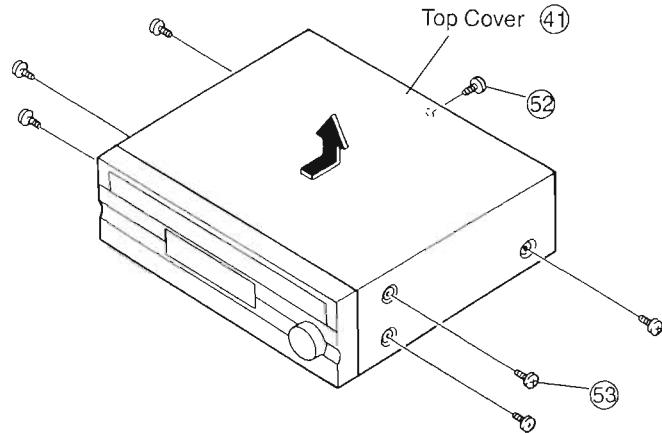

2. Front Panel [Exploded View (1), (2)]

(1) Plug AC cord (25) in wall outlet, press (OPEN/CLOSE) button to open the Loader Panel (2) and then unplug the AC cord.

(2) Remove 3 screws (46)

(3) Remove 2 screws (46) of Front Panel (1) bottom, and unhook 3 hooks.

※ Use care do not damage output terminal by hitting the floor, etc.

(4) Unhook 3 hooks of Front Panel top, and detach the Front Panel.

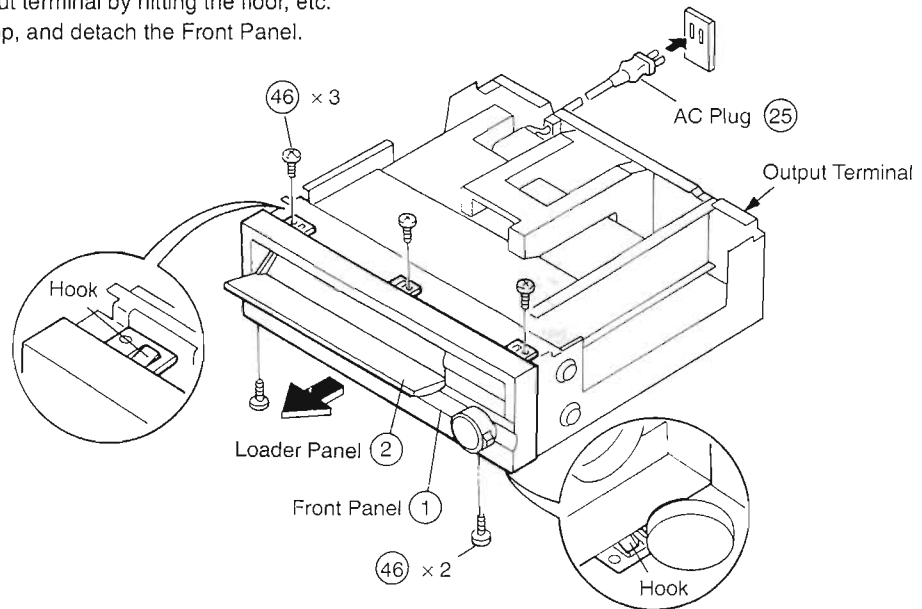

3. Display PCB [Exploded View (2)]

(1) Remove the Jog Dial (14), Shuttle Ring (13), 6 P.W.B. Screws (45) and detach Display P.W.B. from Front Panel rear.

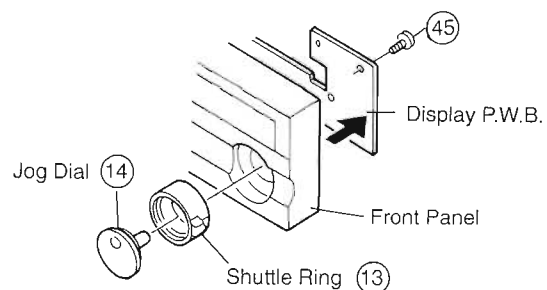

4. Loading Drive Unit Disassembly / Assembly [Exploded View (3)]

- GEN 2420 Tray Drive (Left) Unit
Gear (B) and Pulley Gear

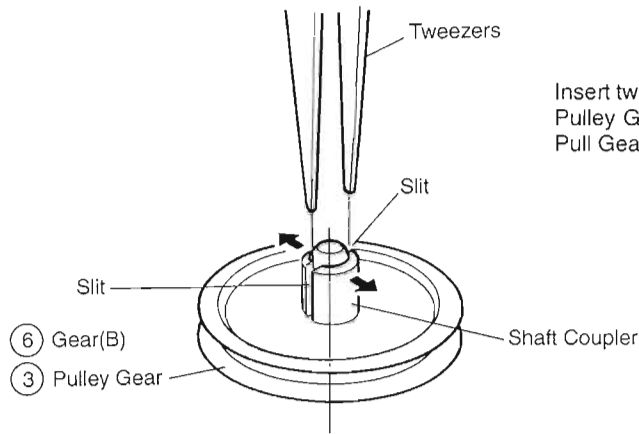

Insert tweezers to the Slit of Gear (B) ⑥ and Pulley Gear ③ , loosen the Shaft Coupler, Pull Gear (B) and Pulley Gear upward.

- To remove parts other than above, reverse the steps shown below.
- ※ Assembly of the loading unit is critical, and unless the work is done properly can invite malfunction.

- GEN 2420 Tray drive (Left) unit

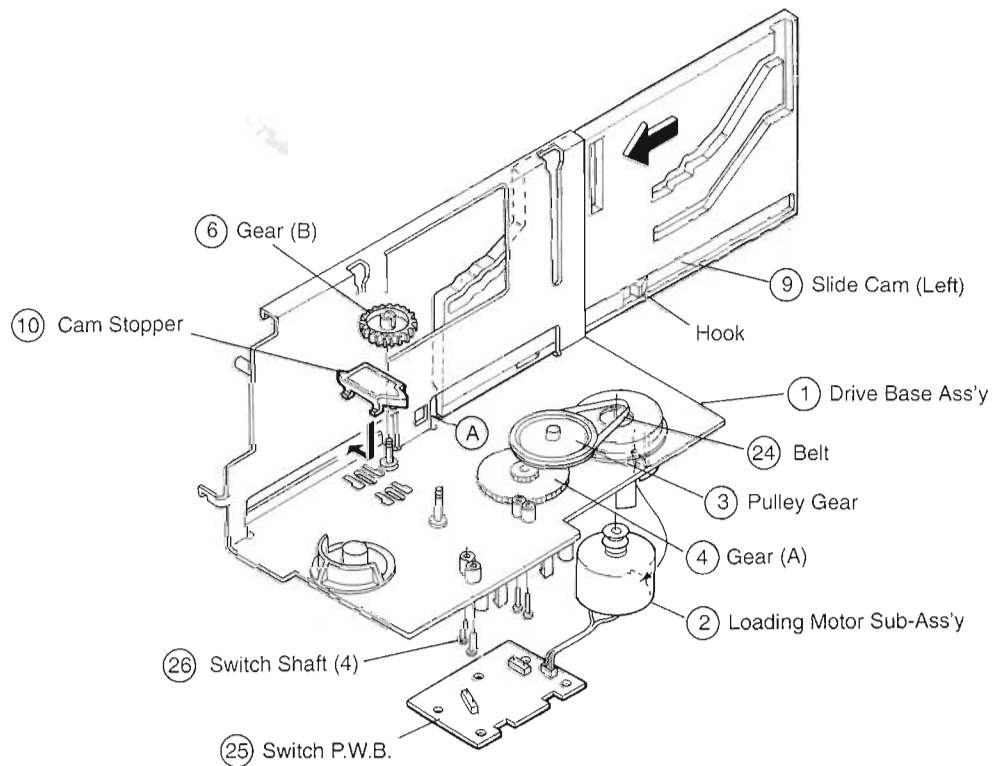

Assembly Step

1. Insert the Switch Shafts ②⑥ to the 4 holes of Drive Base Ass'y ① from bottom side, hook Switch P.W.B. ②⑤ , and then insert Loading Motor Sub-Ass'y to arrow direction and hook it. (The work is reversal of Drive Base Ass'y ①)

2. Insert Gear (A) (4) to the Shaft shown above and then insert the Pulley Gear (3) to the Shaft and push it until the Pulley Gear is hooked.
 3. Install cam Stopper (10) to the position shown above and insert Gear (B) (6) to the Shaft and push it until the Shaft is hooked.
 4. Insert Slide Cam (Left) (9) to arrow direction and move until the hook strikes (A) .
 5. Set the Belt (24) to the pulley of Loading Motor Sub-Ass'y (2) and Pulley Gear (3) .
- Note:** Confirm the belt is clean and free of grease.

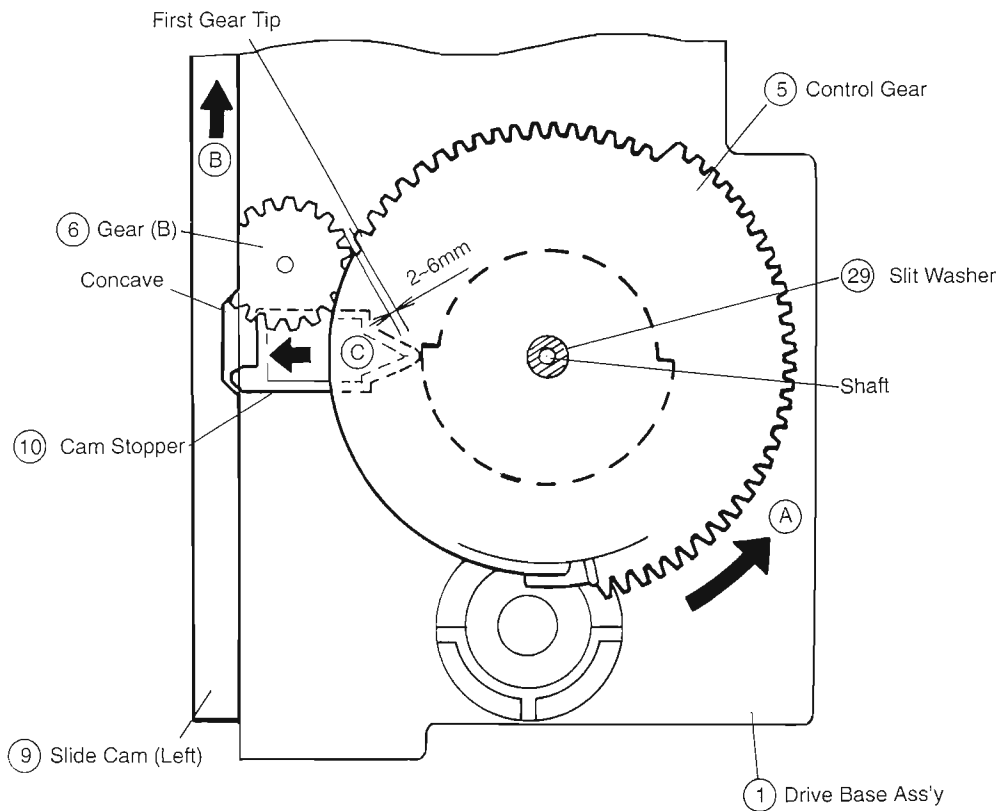

6. Confirm the concave of Slide Cam (Left) (9) is seated at the position shown above, move Cam Stopper (10) to arrow direction (C) , insert Control Gear (5) to the shaft shown above, and confirm the first gear tip is apart from Gear (B) by 2-6 mm, and then fasten it with Slit Washer (29) .

※ After the installation, turn control Gear (5) to arrow direction (A) and confirm the Slide Cam (Left) (9) moves to arrow direction (B) . Then revert the position so that the first gear tip of control Gear (5) sets to the position shown above.

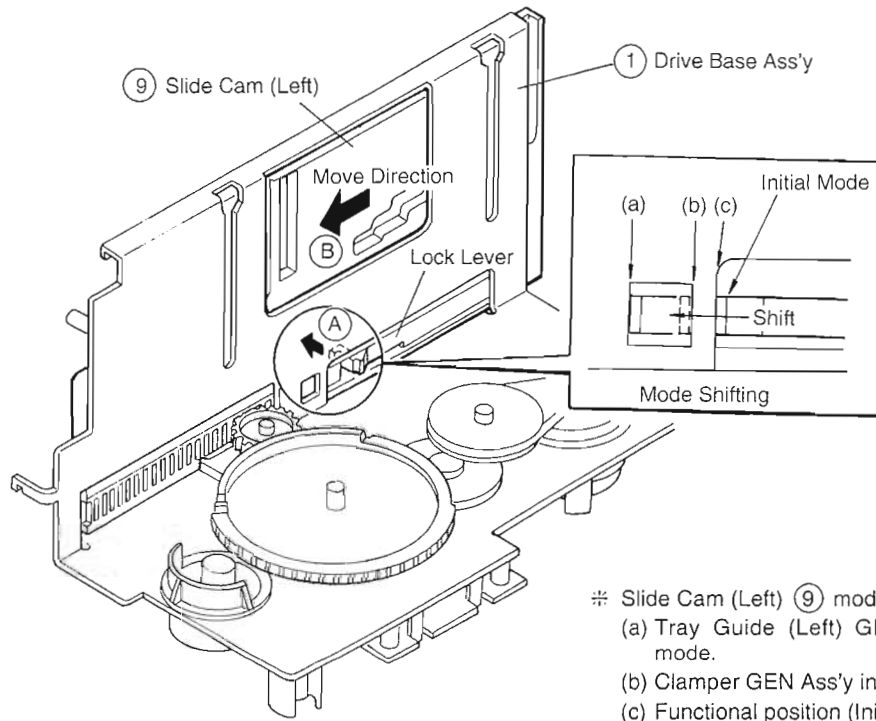

7. Pull Lock Lever of Slide Cam (Left) 9 to arrow direction A and move the Slide Cam (left) 9 to arrow direction B approximately 10mm, and set the Lock Lever to the rectangular window (a) (Tray Guide (left) GEN Ass'y installation mode).

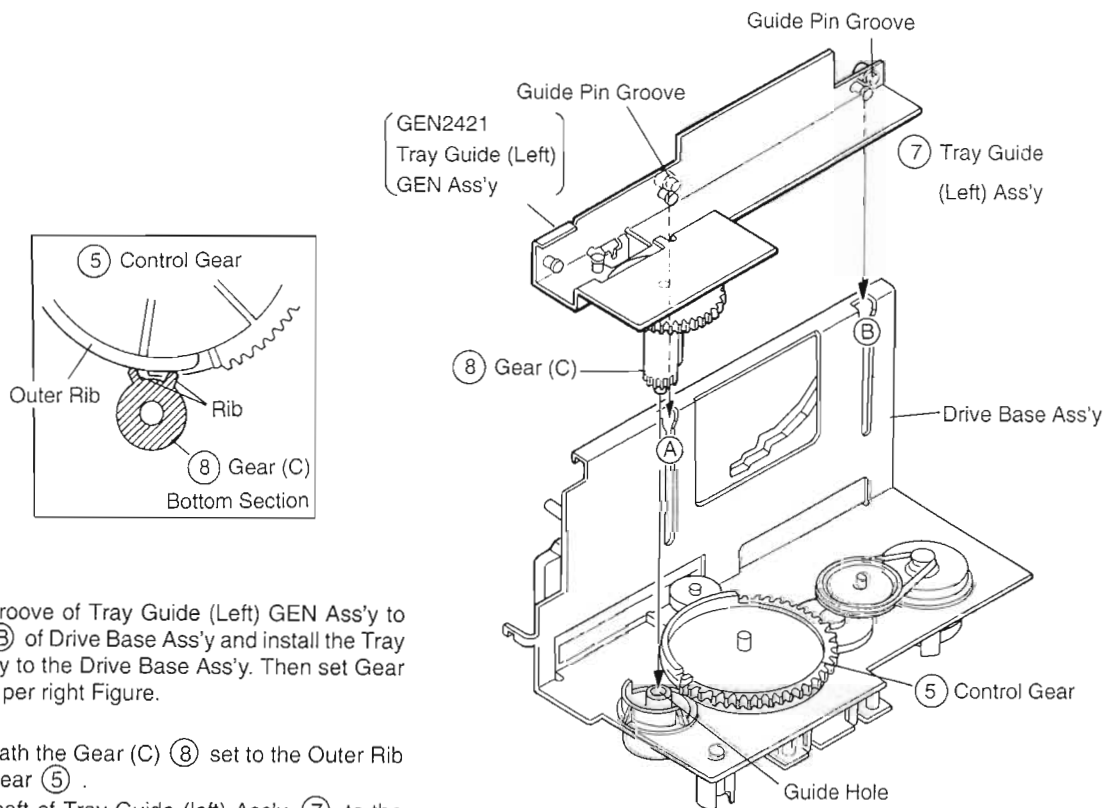

8. Set Guide Pin Groove of Tray Guide (Left) GEN Ass'y to the cut A and B of Drive Base Ass'y and install the Tray Guide (Left) Ass'y to the Drive Base Ass'y. Then set Gear (C) 8 angle as per right Figure.

Note 1: 2 Ribs beneath the Gear (C) 8 set to the Outer Rib of Control Gear 5.

Note 2: Insert the shaft of Tray Guide (left) Ass'y 7 to the Guide Hole of Driver Base Ass'y securely.

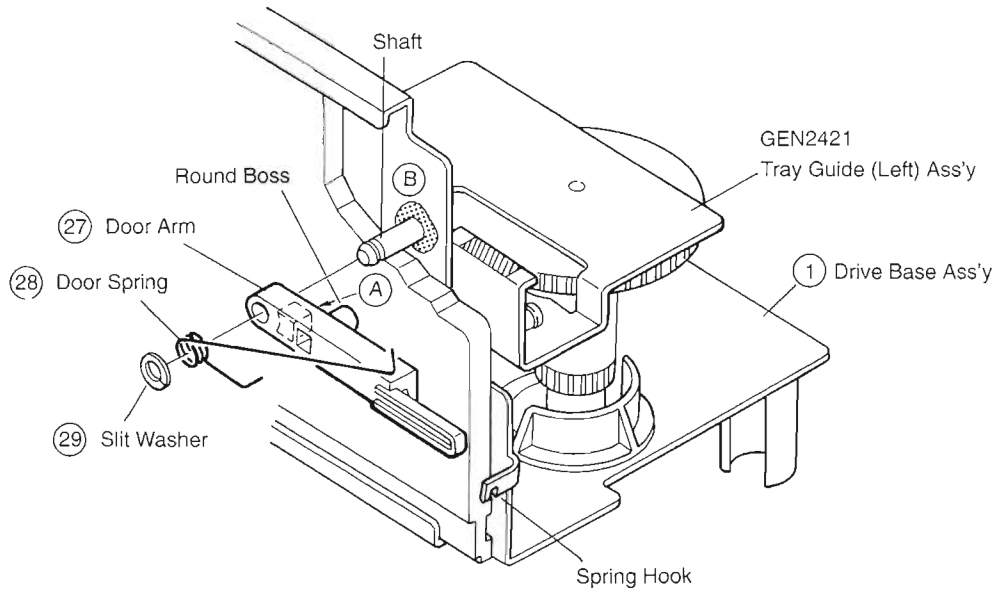

9. Apply redbean amount of Damper Grease (Froil GP837DE) to rectangular hole (A) of Door Arm (27) .
10. Apply red bean amount of Damper Grease (Froil GP837DE) to (B) of Drive Base Ass'y (1) .
11. Insert Door Arm (27) to the Shaft. At this time set the Round Boss of Door Arm to the hatched section of Tray Guide (Left) GEN Ass'y shown above.
12. Set Door Arm Spring (28) to the Shaft as shown below, set the shooter end to rectangular window of Drive Base Ass'y and set the longer end to the hook of Drive Base Ass'y (1) .
13. Secure the spring with the Slit Washer (29) .

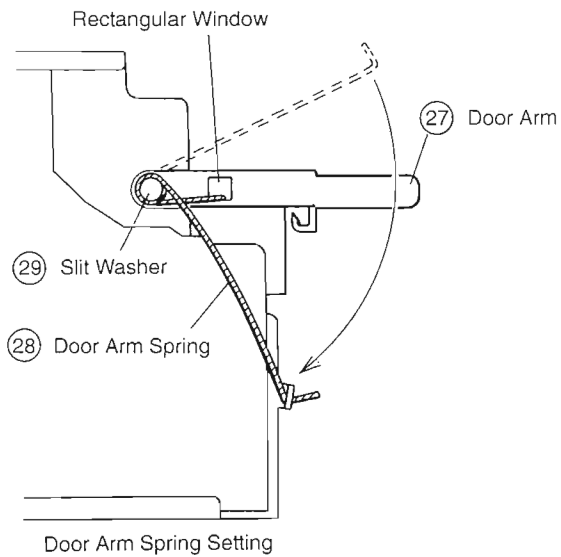

● GEN 2422 Tray Drive (Right) Unit Assembly.

◎ For Disassembly reverse Assembly Steps.

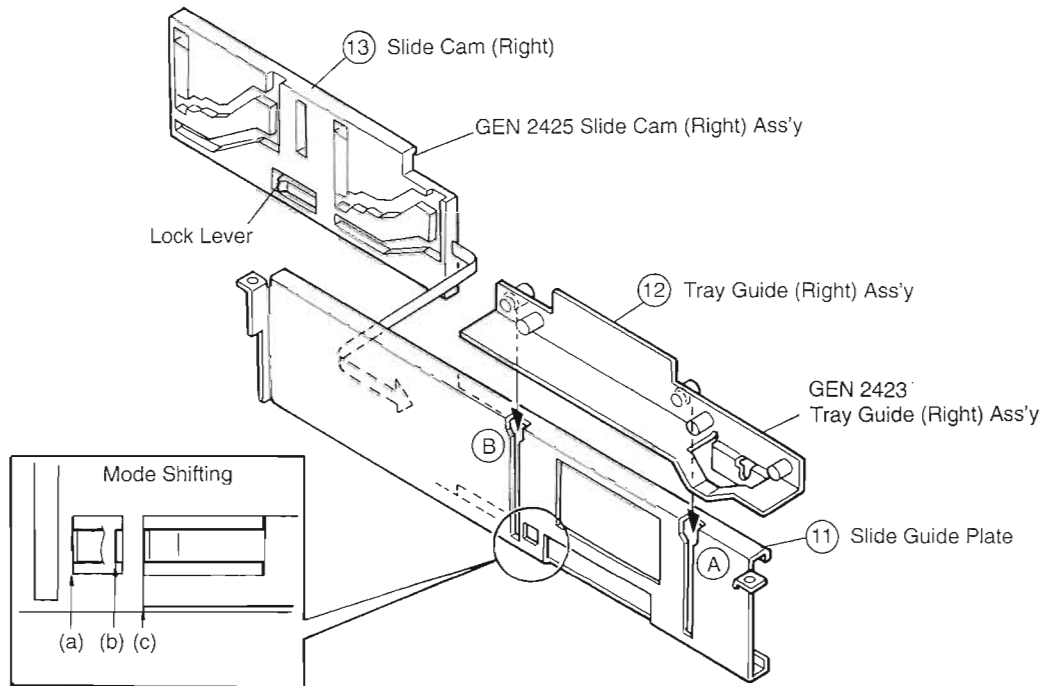

- ✦ Slide Cam (Right) (13) mode shifting.
 - (a) Tray guide (Right) GEN Ass'y Installation mode.
 - (b) Clamper GEN Ass'y Installation mode.
 - (c) Functional position (Initial Mode).

< Assembly Step >

1. Insert Slide Cam (Right) Ass'y to Slide Guide Plate (11) and set Lock Lever as Figure (a) above.
(Tray Guide (Right) GEN Ass'y assembly mode.)
2. In this mode install Tray Guide (Right) GEN Ass'y, and set Lock Lever of Slide Cam (Right) Ass'y as per Figure (b) above (Clamper GEN Ass'y Assembly mode).

● GEN 2424 Clamper GEN Ass'y Assembly

• For disassembly reverse Assembly Steps.

1. Install Rear Panel (31) [exploded view (1)], GEN 2420 Tray Drive (Left) unit, front bridge (35) [Exploded View (1)], GEN 2422 Tray Drive (Right) unit to Chassis (28) [Exploded (1)].
2. Install Slide Cam (Left) of Tray Drive (Left), Slide Cam (Right) Ass'y of Tray Drive (Right) unit to GEN Ass'y, and set to mode (b). (Refer to mode shifting shown above).

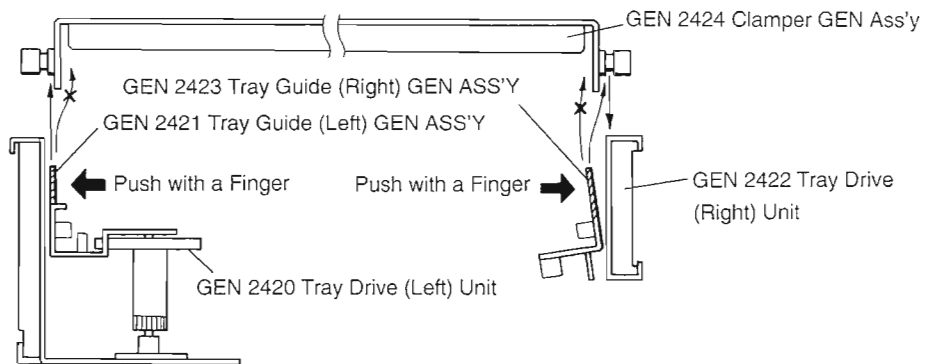

3. After the Joint Gear Ass'y (17) installed, install GEN 2424 Clamper GEN A'ssy. At this time, lightly push outside so that Tray Guide (Left) GEN Ass'y and hatched section of Tray Guide (Right) GEN Ass'y are set to Outer Side of Clamper GEN Ass'y.
4. Set Slide Cam (Left) (9) and Slide Cam (Right) Ass'y to (c). functional mode, and install Connect Plate (19) to Clamper GEN Ass'y with special screw (33) so as it turns freely.
Set a Slit Washer (37) to the special screw (33) before use it.
(Use care for up and down of Connector Plate.)

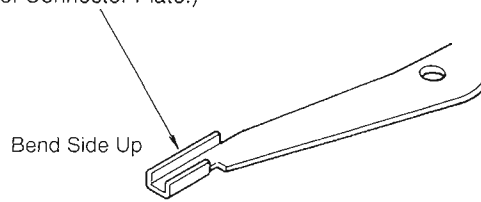

● Tray Ass'y Disassembly

1. Turn power ON to open the tray and then turn power OFF and unplug the AC cord.
(Note: If the tray is pushed by hand, the gear meshes off and invites malfunction.)
2. Push left rear hook (hatched section) of Tray Ass'y to arrow direction at left front Cut Window of Clamper GEN Ass'y, and detach from stopper and pull the Tray Ass'y out.

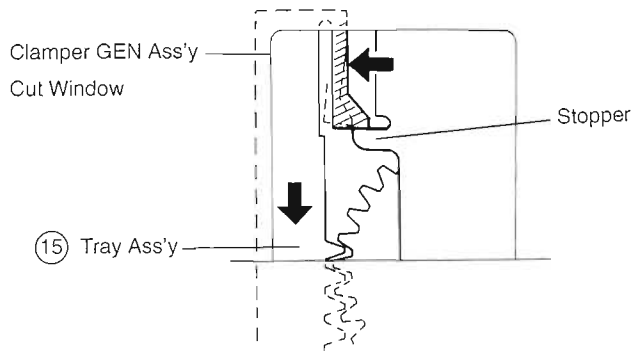

※ Other Caution

If it is necessary to move the Loading Drive Unit when power is OFF, Detach the Front Panel and turn the Pulley Gear which is close to Control Gear or Motor. When the tray is pushed in the set by hand, the Drive Gear is out of mesh, and if other parts are moved, it invites mesh out and malfunction.

● Tray Ass'y Assembly

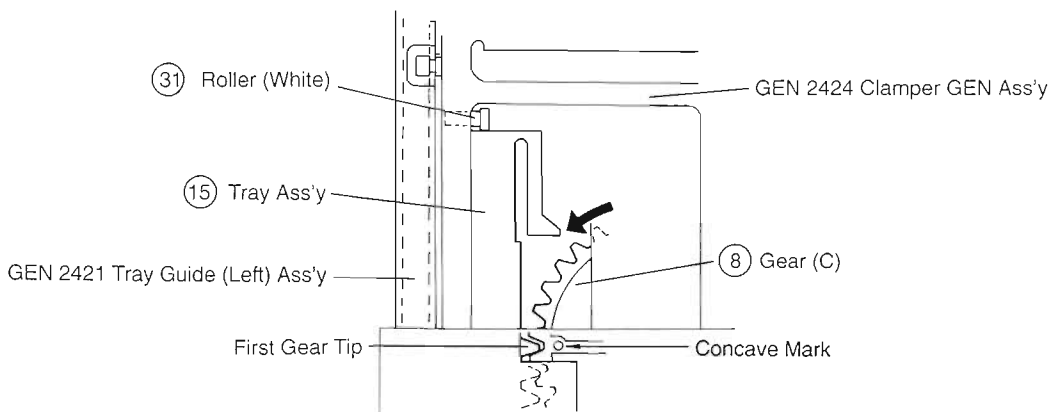

1. Turn power ON, push OPEN/CLOSE button to open the Loader Panel, and the unplug AC cord.

(Figure above shows left front Cut Window of Clamper GEN Ass'y)

2. When insert Tray Ass'y ⑮, turn Gear (C) ⑧ to arrow direction, and set the first gear tip of Tray Ass'y ⑮ to the Concave Mark of Gear (C) ⑧.
3. Then hold the Tray Ass'y ⑮ front end slightly lower, and insert the tray until the end strikes the Roller (White) ⑳. Check both left and right rear of the Tray Ass'y ⑮ strike the Roller (White) ⑳, and after confirming it, hold the Tray Ass'y horizontally, insert the Tray Ass'y so that the front of the tray extrudes 2-3 cm out of the Front Panel.

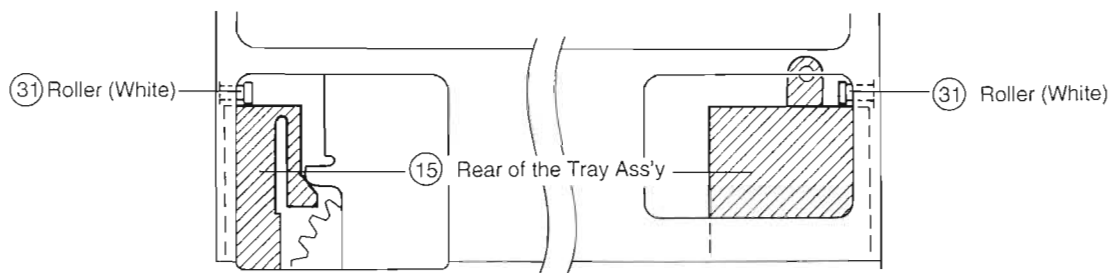

5. Traverse Disassembly [Exploded View (1)]

- (1) Remove 4 screws ④⑧ and detach Traverse Mechanism ③②.

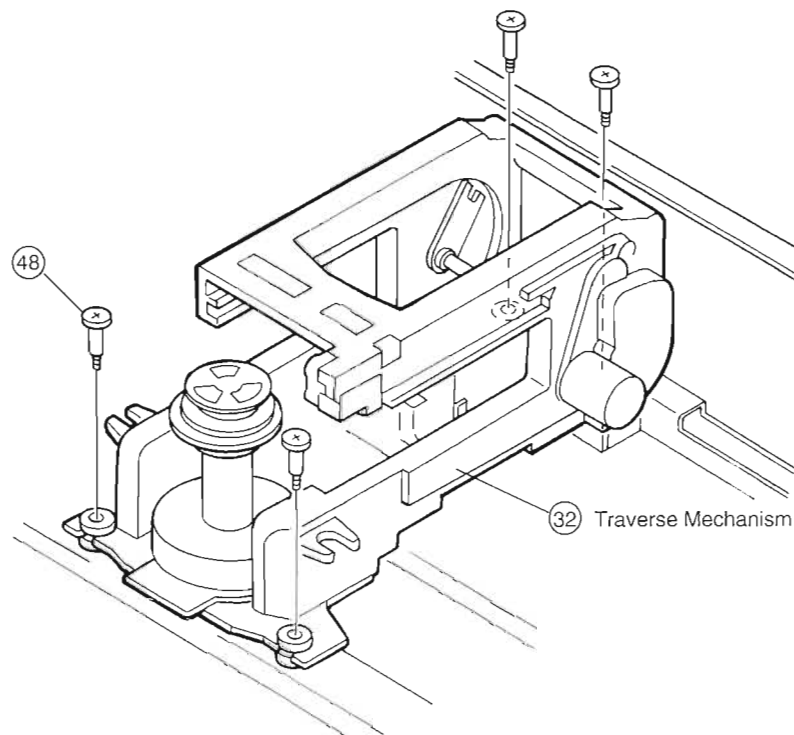

6. P.W.B. Ass'y (Main & Sub) Disassembly [Exploded View (1)]

① P.W.B. Ass'y

- (1) Remove 4 output terminal stay screws (51) .
- (2) Loosen 6 screws (46) .
- (3) Remove 1 screw (47) and 4 screws (46) .
- (4) Pull P.W.B. Ass'y (Front Panel Side) up and forward to detach.

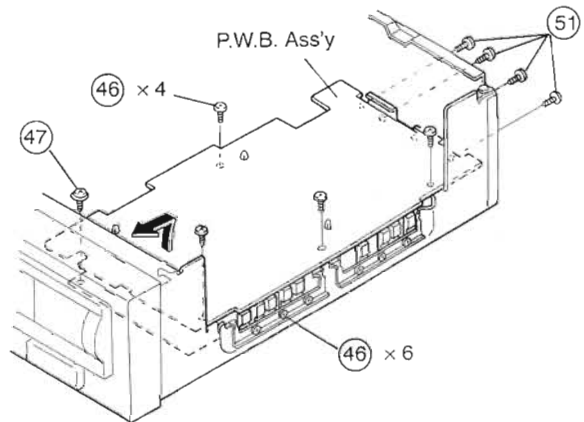

② Main P.W.B. and Sub P.W.B. Disassembly

- (1) Unhook 5 P.W.B. Holders.
- (2) Separate Main P.W.B. from Sub P.W.B. and remove connectors between the P.W.B.s.

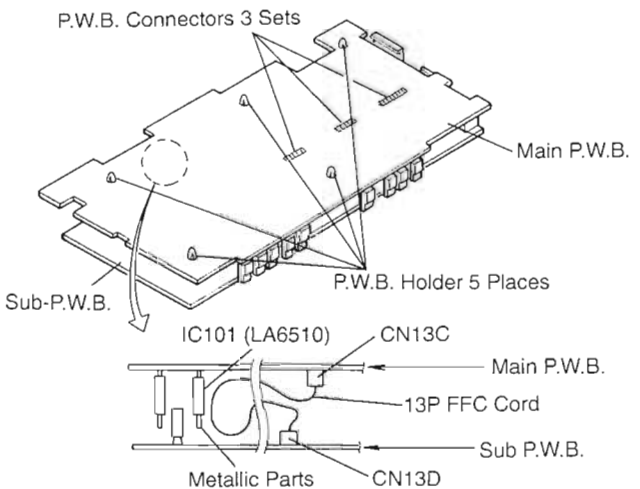

③ Main P.W.B. or Sub P.W.B. Assembly

- (1) Set 3 P.W.B. connectors, and push the P.W.B.s.
- (2) Set 5 P.W.B. holders to holes.
- (3) Check the P.W.B. connectors are inserted securely with the tester.

Caution: Form the 13P FFC cord between P.W.B.s so that it does not touch the fin of IC101.

P.W.B. Ass'y (transformer) Disassembly

- (1) Detach the Code Bush (37) .
- (2) Remove a screw (49) .
- (3) Catch the holder (27) with pincers, and remove it from P.W.B..
- (4) Pull P.W.B. Ass'y (Front Panel Side) up and forward and remove it.

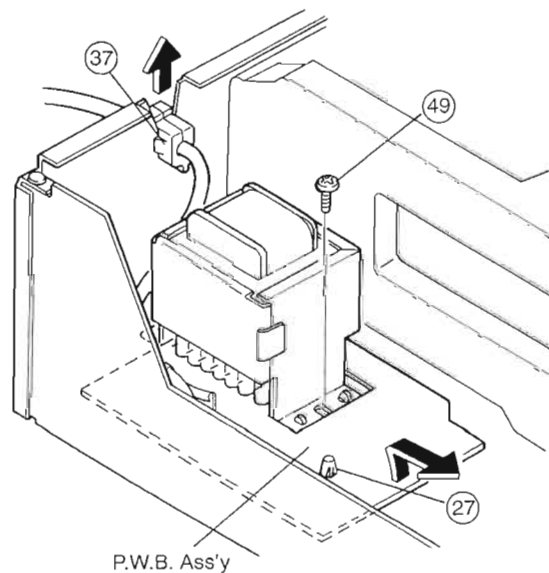

7 Changing Pick Base [Exploded View (4)]

■ Optical Pickup

After changing the Optical Pickup, be sure to adjust servo circuit. The Optical Pickup is fragile : Use enough care to handle it. Never touch Focus Lens, Tilt Sensor and photo detector with a finger.

Disassembly

① Pick Base

1. Remove flexible P.W.B. FP 25011.
2. Slowly move the Pick Base so that set screw of belt clamber appears in the hole of traverse, and remove a belt clamber screw.

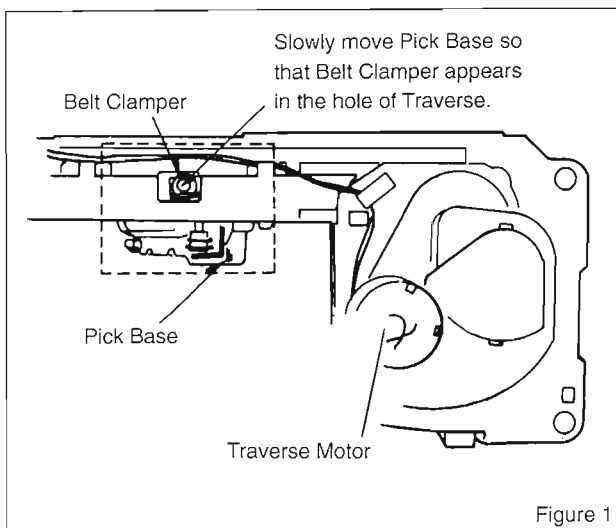

[Traverse Right Side]

3. Remove a shaft holder screw, hold pick base, pull Pick Base up clearing Guide Shaft (A).

Caution: Use care, do not lose Belt Clamber.

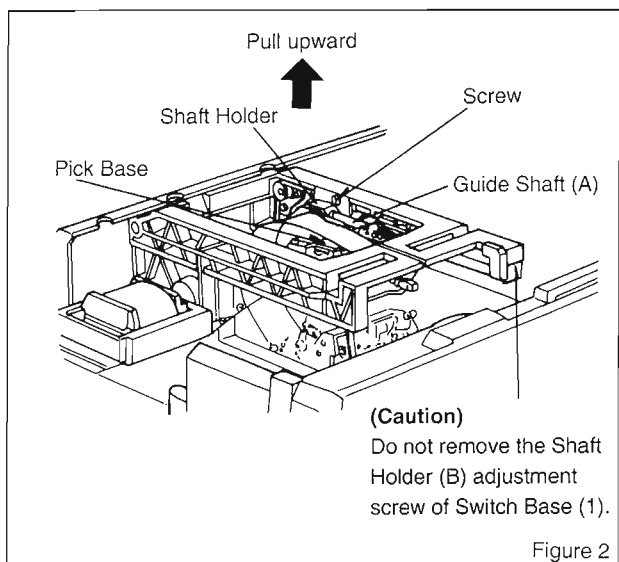

Figure 2

② Optical Pickup

1. ① Remove Flexible P.W.B. from FP25011. Use care, do not damage the Flexible P.W.B..
2. ② Unsolder height base. (To change the Flexible P.W.B., unsolder Tilt Base ⑪ also.)
3. Remove 3 screws (a).
4. Disconnect Optical Pickup.
5. Remove Height Base ② (Refer to "Height base change").
6. Remove height wire springs (A) ③, (B) ④ of height base, (Optical Pickup Shaft (E) side) and tilt pull spring ⑤ (Optical Pickup side).
7. Remove height link plate ⑥ and slowly pull Optical Pickup upward.

Caution: One end of Optical Pickup Shaft (F) has a washer ⑩ . Be sure to use the washer when changing the Optical Pickup. Spare Optical Pickup does not have the Washer.

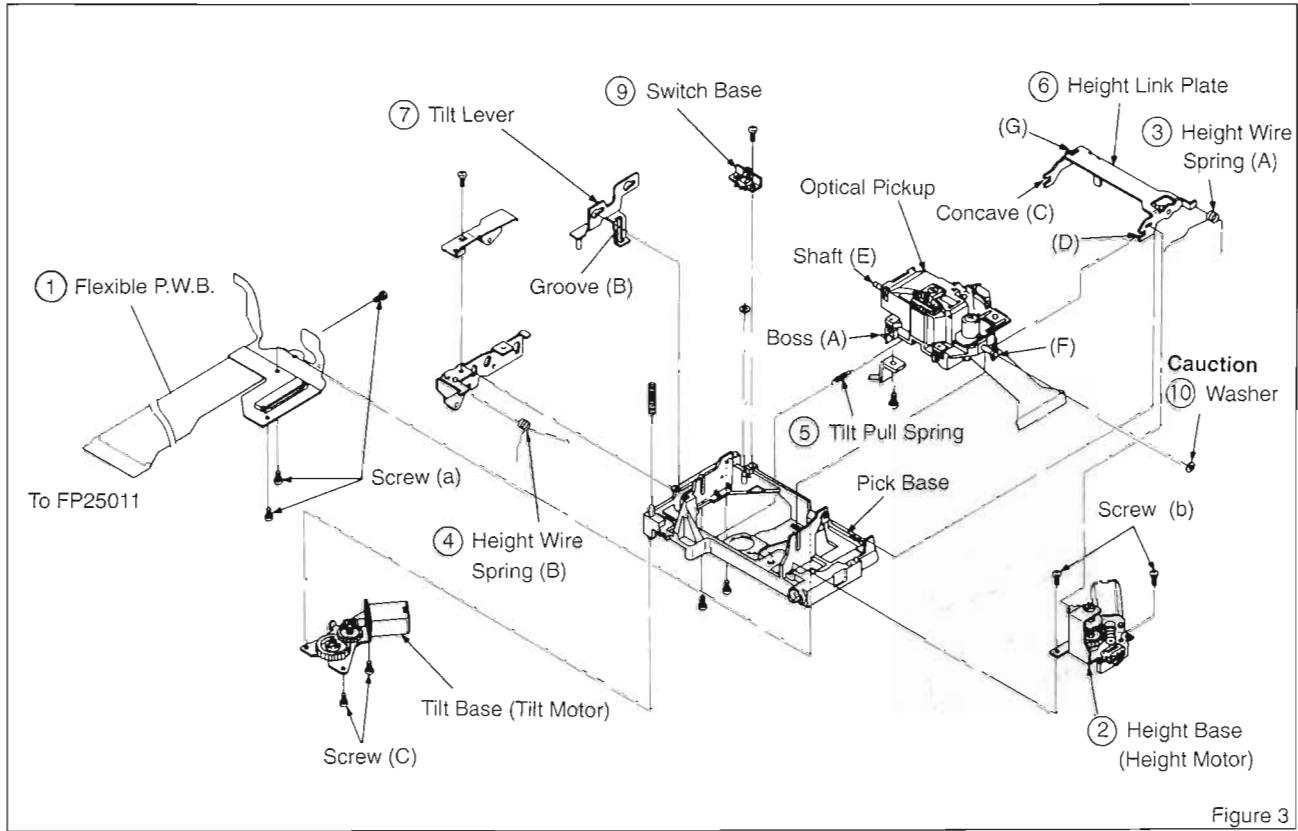

Figure 3

[Pick Base]

Assembly

For assembly reverse disassembly.

① Pick Base

1. Insert Belt Clamper to the concave of Lead Belt Pulley, slowly move Belt Pulley, so that Belt Clamper appears in the hole of Traverse Base.
2. Set Guide Shaft to Pick Base, mount Pick Base downward to Traverse Base and secure the Shaft Holder with a screw (Refer to Figure 2).
3. Set Pick Base to Belt Clamper position and secure the Pick Base with a screw (Refer to Figure 1).

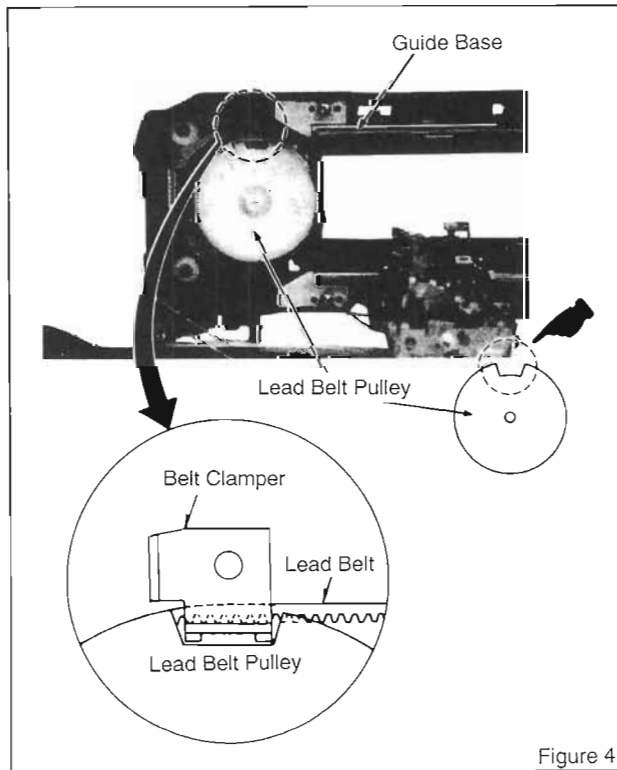
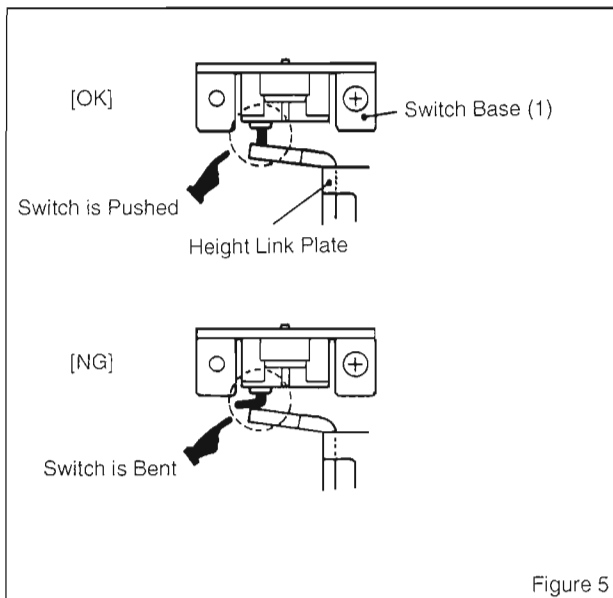

Figure 4

② Optical Pickup

1. Confirm the Boss (A) of Optical Pickup is set to Tilt Lever Groove (B), and install Tilt Pull Spring (5).
2. Install Height Link Plate (6) : Slightly move Optical Pickup so that Concave (C), of Height Link Plate (6), (D) inserted to Pickup Shaft (E) and (F), and confirm (G) of Height Link Plate (6) is pushing the switch of Switch Base (9) as per Figure 3.
3. Install Height Wire Spring (B) (4).
4. Connect Optical Pickup Flexible P.W.B. (1) to relay Flexible P.W.B. and secure the P.W.B. with 3 screws (a).
5. Install Height Wire Spring (A) (3) and Height Base (2).
6. Solder relay Flexible P.W.B. to Height Base (2).



[Switch Base (1) and Height Link Plate Upper Side]

■ Changing Height Base

1. Unsolder Flexible P.W.B. from height motor rear.
2. Remove 2 screws (b).
3. Detach Height Base sideward. Concave of Height Base and Boss of Link Plate are meshed : Slightly move Pickup upward. When install the Height Base, move the Pickup upward and insert the Link Plate Boss to the Concave of Height Base.

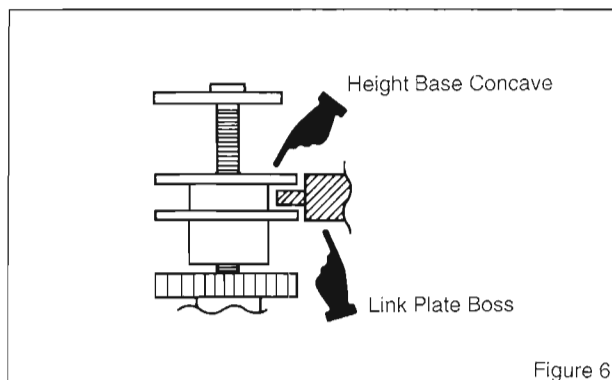

[Height Base (rear view)]

■ Changing Tilt Base

1. Unsolder Flexible P.W.B. from Tilt Motor rear.
2. Remove 2 screws (C).
3. When installing Tilt Base, set Tilt Cam Hole (A) to Tilt Base Hole (B), and secure Tilt Base with 2 screws so that Tilt Lever Boss seats in Tilt Cam Groove. (hatched section).

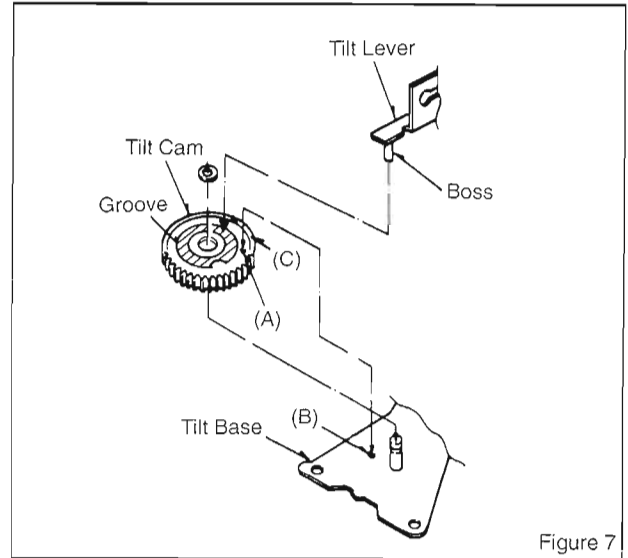

[Tilt Cam]

■ Changing Tilt Sensor

1. Unsolder 4 places.
2. When installing, direct Tilt Sensor Convex Pin as per Figure 8, and solder the Tilt Sensor to Tilt Base so as there is no clearance.

Caution: Use ≈ 40W soldering iron and do it quickly. Use care for the foil of Sensor Base. After changing the Tilt Sensor, Adjust servo.

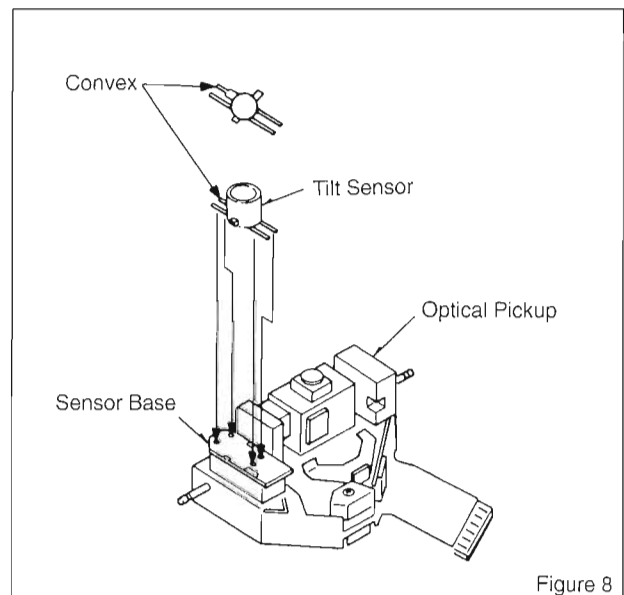

[Tilt Sensor]

8 Checking Audio or Video Circuit

① By using CD and CDV (Video)

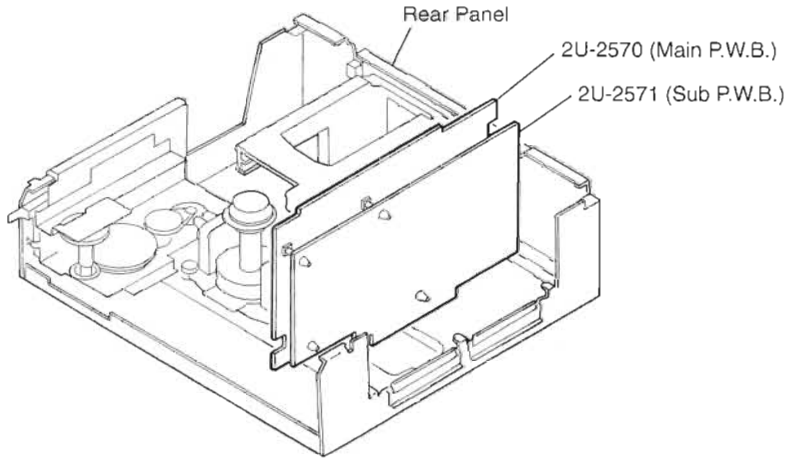

1) Setting

- (a) Remove Top Cover.
- (b) Remove Tray, Connect Plate, Clamper Plate and Slide Guide Plate.
- (c) Stand Main and Sub P.W.B. as per Figure.
- (d) Detach Clamper from Clamper Plate, load a disk as per Figure and clamp the disk.

2) Checking

- Playback the disk in the mode as per the Figure, and check the circuit. Be sure use CD or CDV disk, and never playback LD.
- (a) Video circuit check ... CDV disk video part.
 - (b) Audio circuit check ... CD.

② By using LD

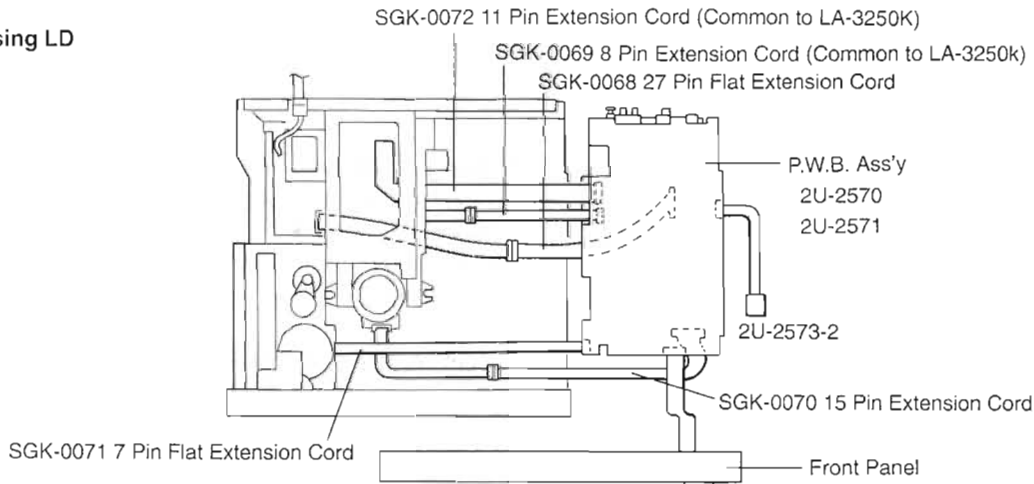

- (a) Remove Top Cover.
- (b) Remove Tray, Connect Plate, Clamper Plate and Slide Guide Plate.
- (c) Remove Front Panel, Regulator P.W.B. (2U-2573-2) and take P.W.B. Ass'y (2U-2570 and 2U-2571) out.
- (d) Connect extension cords to 2 wires to Traverse Mechanism, 1 wire to Spindle Motor, 1 wire to Power Switch P.W.B., and 1 wire to Switch P.W.B. as per Figure above.
Also, change flat cable (27pin, 7pin) with extension cords.

Parts No.	Name	Remarks
SGK-0068	27 pin flat extension cord	Traverse Mechanism Main P.W.B. (Common to LA-3250)
SGK-0069	8 pin extension cord	Traverse Mechanism Main P.W.B. (Common to LA-3250)
SGK-0070	15 pin extension cord	Spindle Motor Main P.W.B.
SGK-0071	7 pin flat extension cord	Switch P.W.B. Main P.W.B.
SGK-0072	11 pin extension cord	Power Switch P.W.B. Main P.W.B.

- (e) Install Slide Guide Plate, Clamper Plate, Connect Plate and Tray.
- (f) Turn power ON, push OPEN/CLOSE button, set a LD to tray and start checking.

ADJUSTMENT

(1) Pickup and Servo

■ Before the Adjustment

1. Changing Pickup (S0AD90A)
 - After changing the Pickup adjust from "2-① tilt balance (A side)" to "2-④ CD focus gain and tracking gain" in the steps shown.
 - "1-① tilt sensor balance" of spare Pickup has already been adjusted, and no adjustment is required.
2. Changing Tilt Sensor (GP2TD01M)
 - After changing the tilt sensor adjust from "1-① tilt sensor balance" to "2-④ CD focus gain and tracking gain" all over.
3. Location of adjustment (on the P.W.B.).

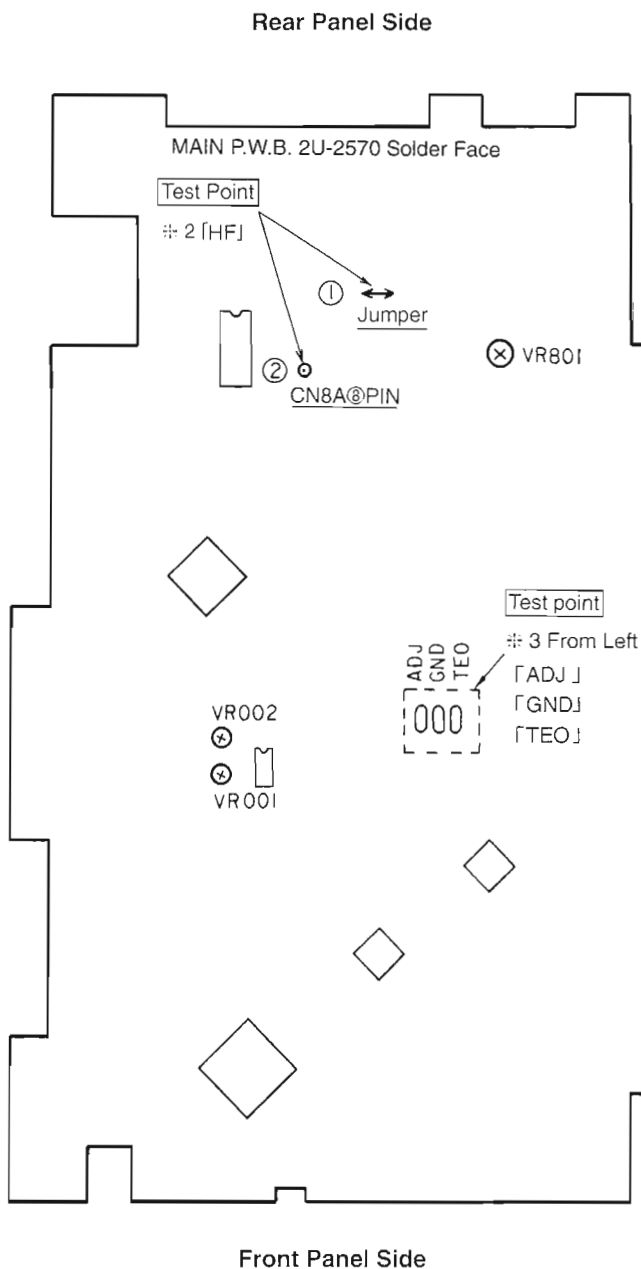

- ※ 1: VR801 is on Sub P.W.B. (2U-2571-1).
- ※ 2: HF
On and from Serial 51 use ①,
Up to Serial 50 use ②.
- ※ 3: Only silk print is wrong on 222 2570 109 P.W.B..

1) Pickup

①	Tilt Sensor Balance.
---	----------------------

Caution: The spare Pickup (S0AD90A) has been adjusted and needs no adjustment.

Measurement Point	Adjust	Mode	Disk
TEO	Tilt Sensor Adjust Screw	Playback B Pause	MTD-04 Chapter 7-8
Measuring Instrument		Adjust to	
Oscilloscope		Kick Pulse Amplitude Maximum	

1. Connect Oscilloscope to "TEO".
2. Playback chapter 7-8 of Test LD MTD-04 (CAV)B, and set the unit to pause mode.
3. Adjust tilt sensor adjustment screw so that kick pulse (Figure 10) amplitude reads maximum.

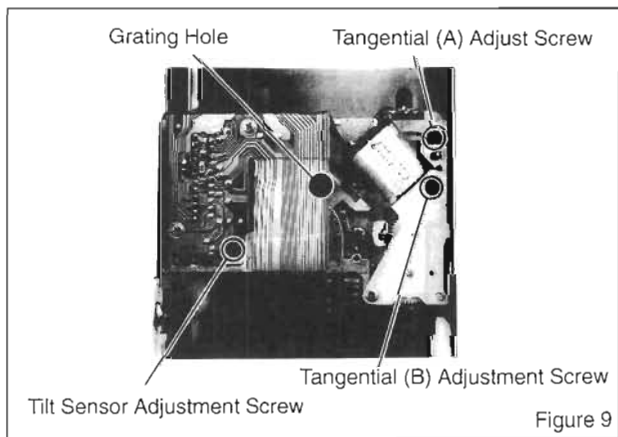

[Pickup Reverse Side]

● Adjustment screw lock paint after the Pickup adjustment lock the screw with lock paint.

1. Screw to be locked
(1) Grating Hole
2. Lock Bond
(1) Name: Three bond

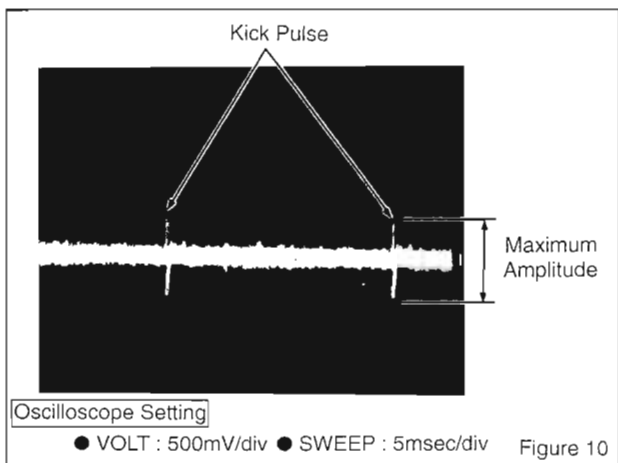

Figure 10

2) Servo

Adjustment Item (step)

- ① Tilt balance A
- ② Tilt balance B
- ③ LD focus and tracking gain
- ④ CD focus and tracking gain
- ⑤ Confirmation after the adjustment

① Tilt balance A

1.	Set VR001 to center position.		
2.	Turn power ON, load Test LD MTD-04, and playback.		
3.	Search chapter 3 and set to PAUSE mode.		
4.			
	Instrument	Adjust	Confirm
	Oscilloscope X : 5mS/div Y : 50mV/div	VR001 Semi-fixed resistor.	
			Kick pulse amplitude A reads maximum.

② Tilt balance B

1.	Set VR002 to center position.		
2.	Push [SIDE B] button and playback B side.		
3.	Search chapter 3 and set to PAUSE mode.		
4.	Same as ① tilt balance A, adjust VR002 so that kick pulse amplitude reads maximum.		

③ LD focus and tracking gain. (automatic)

1.	Turn Secondary power OFF by power switch and set the unit to standby mode.
2.	Ground ADJ terminal. (Leave it grounded : If it opens automatic adjustment mode clears.
3.	Turn secondary power ON by power switch.
4.	Load Test LD MTD-04 and playback.
5.	Search chapter 7 and playback.
6.	Press AUDIO MONITOR of remote controller and confirm 1/L lights and ► flickers on display. (Focus gain adjustment)
7.	After 6–10 second press AUDIO MONITOR and confirm 2/R lights and ► flickers on display. (Tracking gain adjustment)
8.	After 6–10 second press AUDIO MONITOR and confirm 1/L, 2/R and ► light. (automatic adjustment ends)
9.	Remove the disk. To item ④.

④ CD focus and tracking gain. (automatic)

1.	③, item 9 mode.
2.	Load test CD TCD-725 and playback track 1.
3.	Do same as ③, item 6–8.
4.	Open ADJ terminal. (clears automatic adjustment mode)
5.	Remove the disk.

⑤ Confirmation after the adjustment

1.	Playback 4 and 8 of TCD -725 for about 10 seconds and confirm no sound skips.
2.	Search inner and outer circle of A and B of test LD MFD-04 and confirm it works correctly.

Grating

After the adjustment of pickup and servo have been done, playback track 4 and 8 of CD Test disk TCD-725, and confirm no sound skip occurs, and then do the adjustment shown below. And after the adjustment, readjust pickup and servo.

1. Tangential (A side)

Test Point	Adjust	Mode	Disk
HF	Tangential roller (A) Adjustment Screw	Playback	TCD-725 Track 10
Instrument		Adjust to	
Oscilloscope		Refer to Below	

1. Place the unit on the fixture and connect oscilloscope.

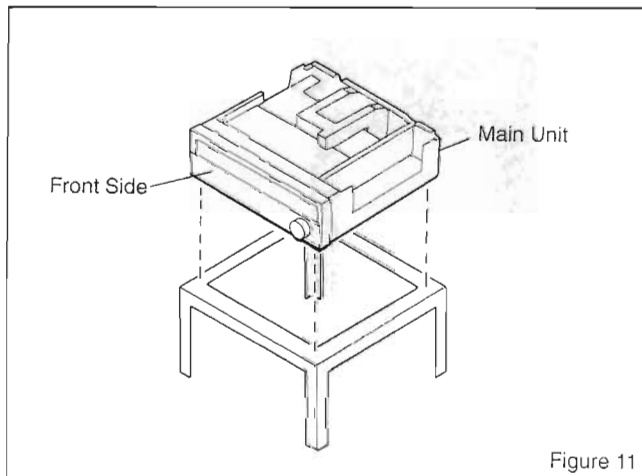

Figure 11

2. Playback track 10 of CD Test disk. (TCD-725)

By playing back track 10 tangential roller (A) [Figure 9] adjustment screw appears in the hole position (A) of the chassis. [Figure 12]

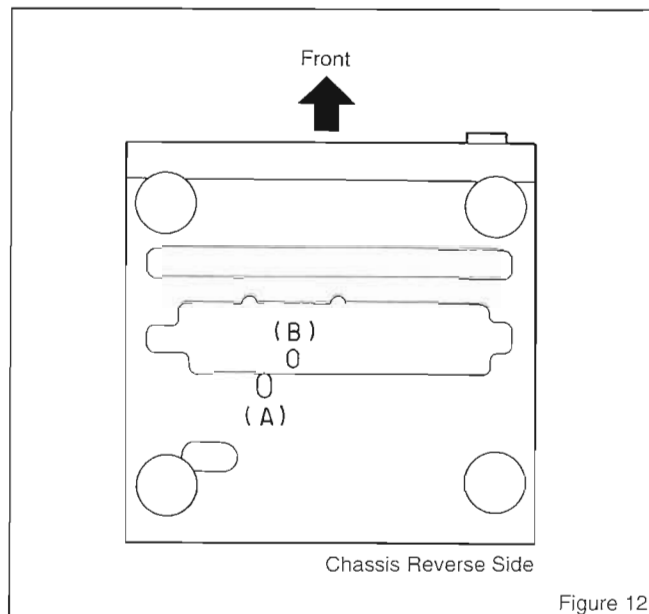

Figure 12

3. Insert a hexawrench (1.5mm) to the hole (A) on reverse side of the chassis [Figure 12], and adjust tangential (A) adjustment screw so that HF eye pattern reads maximum. Then set it to the center of the optimum range.

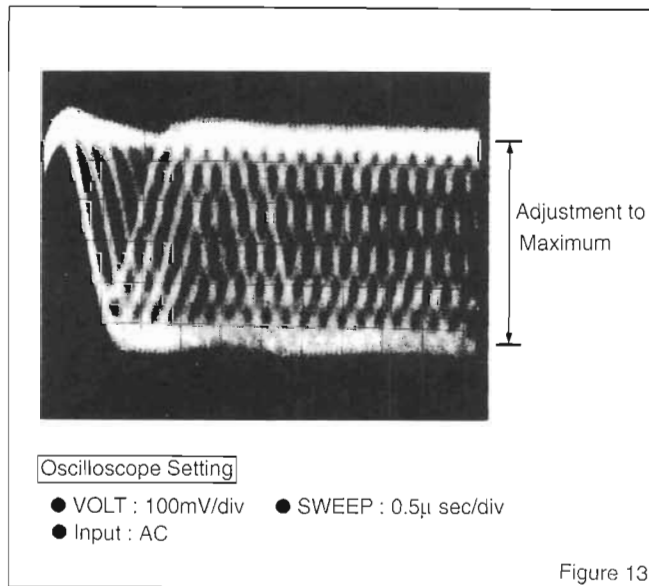

Figure 13

2. Grating

Caution:

Never turn grating adjustment pin too much. (Limits : ± 2-3 degree). Further turn disables RF signal detection and further adjustment.

Test Point	Adjust	Mode	Disk
HF TEO	Grating hole	Playback pause	TCD-725 Track 10
Insturment		Adjust to	
Oscilloscope		Refer to Below	

1. Place the unit on fixture, connect CH 1 of oscilloscope to HF and CH2 to TEO.
2. Playback track 10 of CD test disk (TCD-725).
3. Confirm oscilloscope CH2 TEO shows waveform (A).

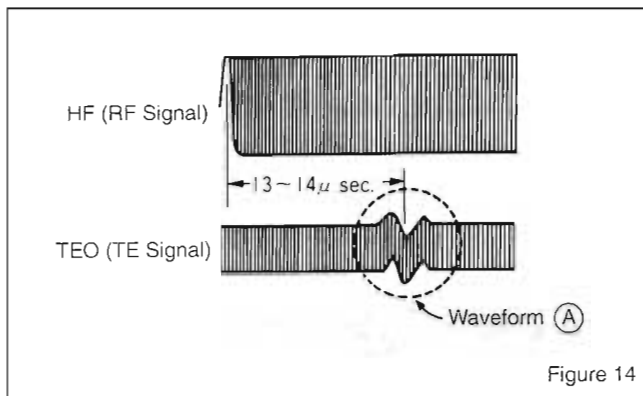

[RF Signal and TE Signal]

4. Set track 10 to playback pause. In this mode, grating hole (Figure 9) comes to the hole position of bottom plate [Figure 12].
5. Insert grating adjustment pin to the hole of bottom plate (B) [refer to Figure 15], and fine adjust the pin so that the maximum amplitude is read. [Figure 10]

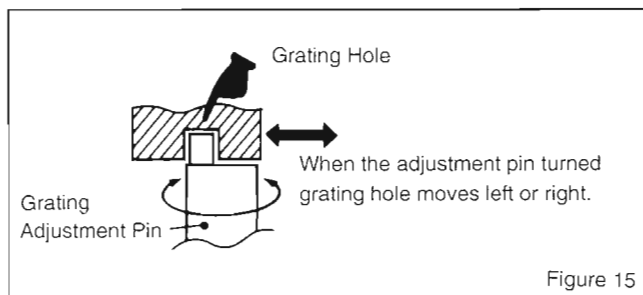

[Grating Hole]

6. Playback track 10 normally.
7. Confire waveform (A) [Figure 14] appears.

3. Tangential (B side)

Test Point	Adjust	Mode	Disk
HF	Tangential roller (B) Adjustment screw	Playback (B)	MTD-04
Insturment		Adjust to	
Oscilloscope		Refer to Below	

1. Connect oscilloscope to HF.
2. Playback B side of MTD-04.

At this time [Figure 9] Tangential Roller (B) Adjustment Screw is visible through the Traverse Base.

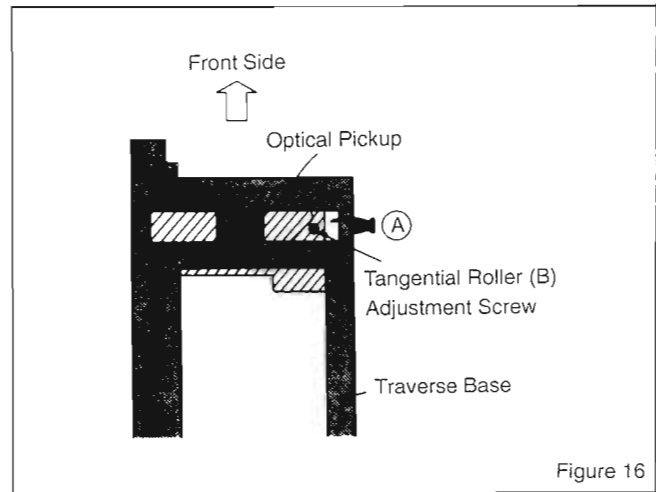

[Traverse Base Upper View]

3. Alternately adjust Tangential Roller (B) Adjustment Screw and VR002 , so that HF eye pattern reads maximum [Figure 13].
Set to the center of the optimum range.

(2) Video

① Video level

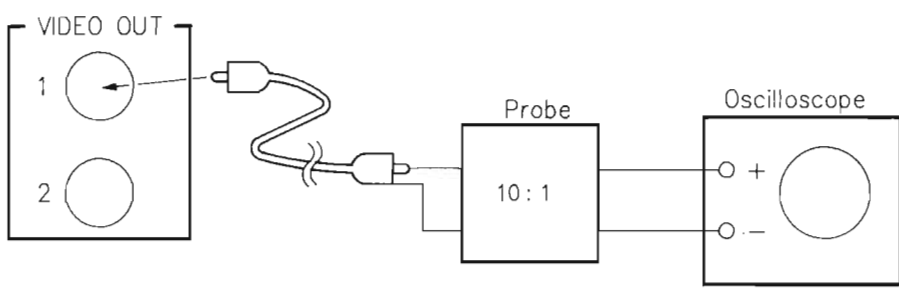
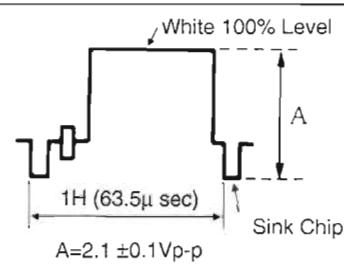
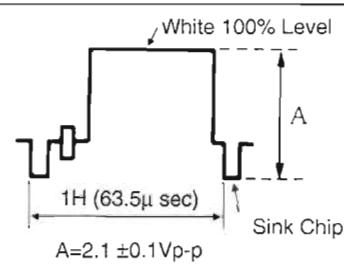
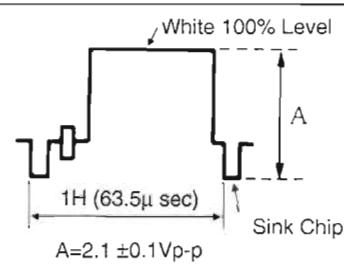
1.	Turn power ON.							
2.	Playback chapter 6 (WHITE) of Test LD MTD-04. (still also function able)							
3.	Connect RCA pin jack cord to Video output terminal, and another end to oscilloscope.							
4.								
	<table border="1"> <thead> <tr> <th>Instrument</th> <th>Adjust</th> <th>Confirm</th> <th>Adjust to</th> </tr> </thead> <tbody> <tr> <td> Oscilloscope 10-20μsec/div 0.5V/div • AC Range </td> <td> VR801 Semi-fixed Resistor in 2U-2571 </td> <td>  </td> <td> Adjust VR801 to set video signal amplitude. (Sink Chip ~ white 100% : A) </td> </tr> </tbody> </table>	Instrument	Adjust	Confirm	Adjust to	Oscilloscope 10-20μsec/div 0.5V/div • AC Range	VR801 Semi-fixed Resistor in 2U-2571	
Instrument	Adjust	Confirm	Adjust to					
Oscilloscope 10-20μsec/div 0.5V/div • AC Range	VR801 Semi-fixed Resistor in 2U-2571		Adjust VR801 to set video signal amplitude. (Sink Chip ~ white 100% : A)					
5.	Stop							
6.	Turn power OFF.							

By the adjustment video output level is $1.0 \pm 0.05V/75\Omega$.

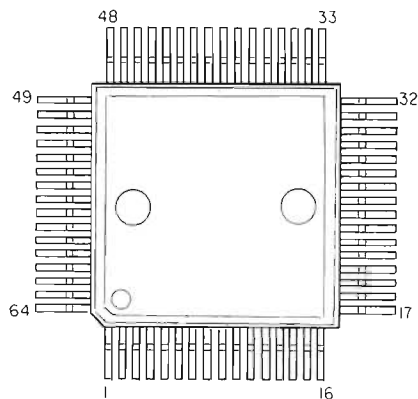
SEMICONDUCTORS
IC MN66601VRRD (IC001)

MN66601VRRD2 Terminal Function

Pin No.	Symbol	I/O	Function
1	SRF	I	Playback RF signal input.
2	FG	I	Spindle FG signal input.
3	SPSTOP	O	Spindle stop command output (H: Stop).
4	FG/N	O	Spindle FG signal dividing output.
5	PBSYNC	I	Playback H sync signal input (Low pulse).
6	REFH	I	Reference H sync signal input (Low pulse).
7	CDEC	I	CD spindle drive input (Analog switch input).
8	CDSPDRV	O	CD spindle drive output (Analog switch output).
9	TEST0	O	Test terminal (Normally open).
10	TEST1	O	Test terminal (Normally open).
11	TEST2	O	Test terminal (Normally open).
12	TEST3	O	Test terminal (Normally open).
13	TEST4	O	Test terminal (Normally open).
14	TEST5	O	Test terminal (Normally open).
15	TEST6	O	Test terminal (Normally open).
16	TEST7	O	Test terminal (Normally open).
17	XI	I	X'tal input.
18	XO	O	X'tal output.
19	TSCK	I	Test terminal (Normally L).
20	/TEST	I	Test terminal (Normally H).
21	VSS	I	Power supply (Digital system, 0V).
22	VDD	I	Power supply (Digital system, +5V).
23	SCPHASE	O	Sub-carrier phase shifting output.
24	/RESET	I	Reset terminal (L: Reset).
25	SENSE4	O	Processor status output 4.
26	SENSE3	O	Processor status output 3.
27	SENSE2	O	Processor status output 2.
28	SENSE1	O	Processor status output 1.
29	MREADY	O	Microcomputer command acceptable output (H: Acceptable).
30	MLD	I	Microcomputer command load signal input (L: Load).
31	MCLK	I	Microcomputer command clock input (Latches data at rising edge).
32	MDATA	I	Microcomputer command data input (Positive logic).
33	LDSPDRV	O	LD spindle drive output (PWM output) 3 state.
34	HITDRV	O	Height drive output (PWM output) 3 state.

Pin No.	Symbol	I/O	Function
35	TRVDRV	O	Traverse drive output (PWM output) 3 state.
36	TIL TDRV	O	Tilt drive output (PWM output) 3 state.
37	SPAREO0	O	Test terminal (Normally open).
38	SPAREO1	O	Test terminal (Normally open).
39	SPAREI0	I	Test terminal (Normally L).
40	N/R	O	Obverse/Reverse playback mode switching output (L: Reverse).
41	/TRON	O	Tracking servo ON signal (L: ON).
42	SDO	O	Drop out detection signal input (H: Drop out).
43	/HTDWN	I	Height mechanism down limit signal (L: Down).
44	/LDON	O	Laser ON control output (L: ON).
45	AV	O	CD/LD playback mode shifting output (H: CD).
46	BDO	I	Black drop out signal (H: Drop out).
47	OFTR	I	Off track detection signal (H: OFF track).
48	CROSS	I	Track cross signal input.
49	FODRV	O	Focus drive output (D/A output), +: Up, -: Down.
50	TRDRV	O	Tracking drive output (D/A output), +: Outer, -: Inner.
51	TRBAL	O	Tracking balance output (D/A output), +: +side gain up.
52	FOBAL	O	Focus balance output (D/A output), +: +side gain up.
53	TIBAL	O	Test terminal (Normally open).
54	VREF+	I	A/D, D/A reference power supply (+4V).
55	VREF-	I	A/D, D/A reference power supply (+1V).
56	AVSS	I	Power supply (Analog system, 0V).
57	AVDD	I	Power supply (Analog system, +5V)
58	TE	I	Tracking error signal input (A/D input), +: Inner, -: Outer.
59	FE	I	Focus error signal input (A/D input), +: Far, -: Near.
60	TILT-	I	Tilt sensor -signal input (A/D input), +: Outer, -: Inner.
61	TILT+	I	Tilt sensor +signal input (A/D input), +: Inner, -: Outer.
62	RFp-p	I	RF peak-peak envelope signal input (A/D input), +: Large.
63	RFENVB	I	Bright side RF envelope signal input (A/D input), +: Dark.
64	ADSPARE	I	Test terminal (Normally connect to RFENVB).

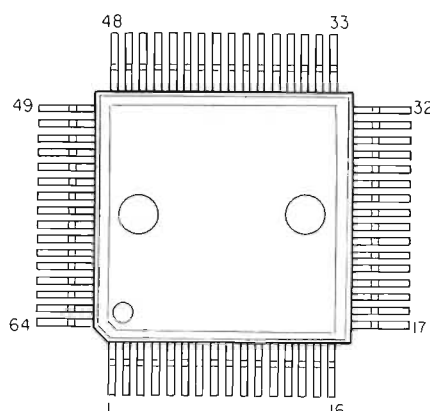
IC MN6626 (IC601)



MN6626 Terminal Function

Pin No.	Symbol	I/O	Function	Pin No.	Symbol	I/O	Function
1	AVSS	I	GND for DSL, PLL circuit (0V).	36	SUBQ	O	Subcode Q code output.
2	IREF	I	Reference current input terminal.	37	SQCK	I	External clock for subcode Q register.
3	ARF	I	RF signal input terminal.	38	/CLOCK	O	Subcode frame clock signal (f CLOCK = 7.35 kHz).
4	DRF	I	Bias terminal for DSL.	39	BLKCK	O	Subcode frame clock signal (f BLKCK = 75Hz).
5	DSL F	O	Loop filter terminal for DSL.	40	DEMPH	O	Deemphasis ON signal, H: ON.
6	PLL F	I/O	Loop filter terminal for PLL.	41	MEMP	I	Emphasis signal input (For digital audio interface).
7	AVDD	I	Power supply for DSL, PLL circuit (+5V).	42	MLD	I	Microcomputer command load signal input, L: Load.
8	RSEL	I	RF signal polarity specifying terminal, RSEL=H at bright level "H". RSEL=L at bright level "L".	43	MCLK	I	Microcomputer command clock signal input (Latches data at rising edge).
9	TBUS7	O	Test terminal (Normally open).	44	MDATA	I	Microcomputer command data input.
10	TBUS6	O	Test terminal (Normally open).	45	DMUTE	I	Muting input, H: Mute.
11	TBUS5	O	Test terminal (Normally open).	46	SMCK	O	1/2 divided clock signal of X'tal oscillation at MSEL = H (f SMCK = 8.4672MHz). 1/4 divided clock signal of X'tal oscillation at MSEL = L (f SMCK = 4.2336MHz).
12	TBUS4	O	Test terminal (Normally open).	47	STAT	O	Status signal (CRC, CUE, CLVS, TTSTOP, FCLV, SQOK).
13	TBUS3	O	Test terminal (Normally open).	48	CRC	O	Subcode CRC check result, H: OK, L: NG.
14	TBUS2	O	Test terminal (Normally open).	49	SUBC	O	Subcode serial output data.
15	TBUS1	O	Test terminal (Normally open).	50	SBCK	I	Clock input for subcode serial output.
16	TBUS0	O	Test terminal (Normally open).	51	/TRON	I	Tracking servo ON signal, L: ON.
17	FLAG	O	Flag output terminal.	52	CLVS	O	Spindle servo phase sync status signal, H: CLV, L: Rough servo.
18	IPFRAG	O	Interpolation flag, H: Interpolation.	53	PC	O	Spindle motor ON signal, L: ON.
19	FCLK	O	Crystal system frame clock (f FCLK = 7.35 kHz).	54	ECM	O	Spindle motor drive signal (Forced mode output, 3-state).
20	BYTCK	O	Byte clock.	55	ECS	O	Spindle motor drive signal (Servo error signal output), 3-state.
21	WDCK	O	Word clock	56	VDD	I	Power supply (+5V).
22	/RST	I	Reset input, L: Reset.	57	/TEST	I	Test terminal (Normally H).
23	TX	O	Digital audio interface output signal.	58	SSEL	I	Sub Q terminal, Output mode shifting terminal, H: Q code buffer using mode.
24	LDG	O	Lch digital signal.	59	MSEL	I	SMCK terminal, Output frequency shifting terminal, H: SMCK = 8.4672 MHz, L: SMCK = 4.2336 MHz.
25	RDG	O	Rch digital signal.	60	RESY	O	Re-sync signal of frame sync, H: Sync, L: Out of sync.
26	SRDATA	O	Serial data output.	61	DO	I	Drop out signal, H: Drop out.
27	SCK	O	Bit clock for SRDATA.	62	EFM	O	EFM signal output.
28	LRCK	O	L, R check signal.	63	PCK	O	PLL extract clock output (f PCK = 4.3218 MHz).
29	XCK	O	X'tal oscillation clock output (f XCK = 16.9344 MHz).	64	PDO	O	Phase comparing signal of EFM signal and PCK signal.
30	PMCK	O	1/192 divided clock signal of X'tal oscillation (f PMCK = 88.2 kHz).				
31	CSEL	I	Test terminal (Normally L).				
32	PSEL	I	Test terminal (Normally L).				
33	X1	I	X'tal oscillation circuit input terminal (f = 16.9344 MHz).				
34	X2	O	X'tal oscillation circuit output terminal (f = 16.9344 MHz).				
35	VSS	I	Power supply (0V).				

IC CXA1145M (IC503)

Block Diagram

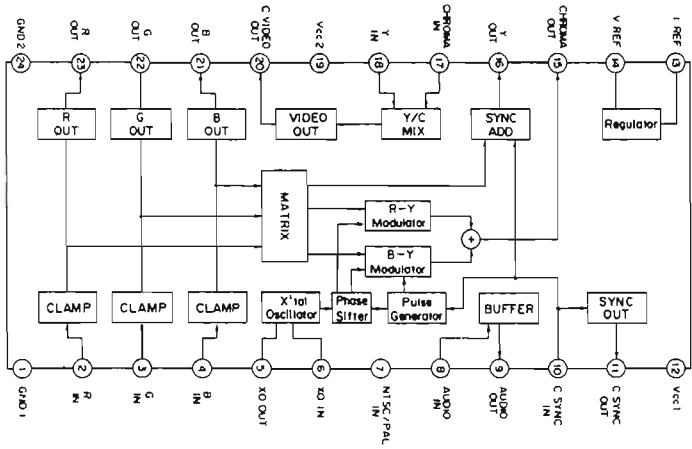
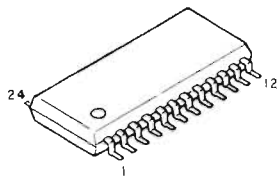

CXA1145M Terminal Function

Pin No.	Symbol	Function
1	GND1	GND Terminal for other circuits than RGB output, composite video output circuit. Connect to GND2 with impedance as low as possible.
2 3 4	R IN G IN B IN	Input terminal for analog RGB signal. Input at 100%=1Vp-p. It is necessary to input with impedance as low as possible, in order to lessen clamp error rate.
5	XO OUT	Input terminal for X'tal OSC. In case to use by internal oscillation, connect quartz oscillator. In case to use by external oscillation, input it into 6 pin terminal XO IN through coupling capacitors. Input subcarrier at level of 400mVp-p-1,000mVp-p. When using by external oscillation, input minimal distortion sine wave. With great distortion, there is possibility of deterioration of phase characteristic of chroma signal.
6	XO IN	
7	NTSC/PAL IN	Switching terminal of NTSC, PAL modes. Vcc NTSC GND PAL
8	AUDIO IN	Audio buffer amplifier circuit input terminal. Input impedance is approx, 25kohm.
9	AUDIO OUT	Audio buffer amplifier circuit output.
10	C SYNC IN	Composite sync signal input terminal. Input on TTL level. At L ($\leq 0.8V$) :SYNCH H ($\geq 2.0V$)
11	C SYNC OUT	Composite sync signal output terminal. Able to drive directly load of 75ohm.
12	Vcc1	Power supply terminal for other circuit than RGB output circuit, composite video output circuit.
13	IREF	Terminal to determine internal reference current. Connect to GND across 27kohm.
14	VREF	Internal reference voltage terminal. Ground by approx. 10 μ F capacitor.
15	C OUT	Chroma signal output terminal. Connect BPF(Band pass filter) across 17 pin(CIN).
16	Y OUT	Y-signal output terminal. Connect DL(Delay line) across 18 pin(Y IN).
17	C IN	Input terminal for chroma signal from which high frequency is cut off by BPF (Band pass filter).
18	Y IN	Input terminal to input delayed Y signal by DL (Delay line).
19	Vcc2	Power supply terminal of RGB output circuit, composite video output circuit. Couple with sufficiently capacity capacitor as large current flows.
20	C VIDEO OUT	Output terminal of Y/C MIX circuit. Outputs composite video signal. Able to drive directly load of 75ohm.
21 22 23	B OUT G OUT R OUT	Output terminal of analog RGB signal. Able to drive directly load of 75ohm.
24	GND2	GND terminal of RGB output circuit, composite output circuit. Connect to GND1 with impedance as low as possible.

IC MN8811 (IC801)

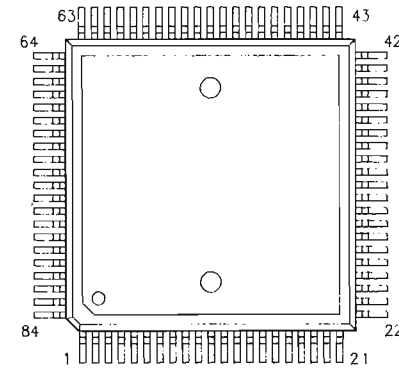

MN8811 QFP084-P-1818 Terminal Function

Pin No.	Symbol	I/O	Function
1	RCK1	I	Read out clock input, connect to RCK0.
2	RCK0	O	Read out clock output.
3	RK0	O	RX1 reversal amplifier output.
4	RX1	I	Input terminal of spurious component eliminated phase modulated output by ceramic filter.
5	TMODE	I	Test mode shifting terminal, H: Test mode, L: Normal mode.
6	PMDOLT	O	Read out side phase modulator output.
7	DSOUT7	O	Video signal digital output. MSB: DSOUT7
8	DSOUT6		
9	DSOUT5		
10	DSOUT4		
11	DSOUT3		
12	DSOUT2		
13	DSOUT1		
14	DSOUT0		
15	WH	O	Separated horizontal sync signal from video signal emitting to DAOUT (Polarity : Negative). Used as read out reference of field memory when connecting MX8812.
16	WV	O	Separated vertical sync signal from video signal emitting to DAOUT (Polarity : Negative). Used as read out reference of field memory when connecting MX8812.
17	RH	O	Horizontal sync signal made by reference sync generating circuit (Polarity : Negative). Used as read out reference of field memory when connecting MX8812.
18	RV	O	Vertical sync signal made by reference sync generating circuit (Polarity : Negative). Used as read out reference of field memory when connecting MX8812.
19	RFS2	O	RCK ÷ 2 (5.15MHz).
20	RFS	O	RCK ÷ 4 (3.56MHz).
21	EXTERR	I	Error data input terminal of read out clock phase modulation (φ M). Input by 8-bit serial data when connecting M8812.
22	DVSS		Digital system ground (logic section).
23	DVDD		Digital system power supply (Logic section ÷ digital section).
24	DVSS		Digital system ground (D/A digital section).
25	AVSS		Analog system ground (D/A analog section).
26	AVDD		Analog system power supply (D/A analog section).
27	VREF	I	D/A converter reference voltage setting terminal (Reference voltage for full scale current adjustment).

Pin No.	Symbol	I/O	Function
28	IREF	I	D/A converter reference voltage setting resistor connecting terminal (Reference resistor for full scale current adjustment).
29	COMP	I	Capacitance connecting terminal for phase compensation.
30	VIB	I	Capacitance connecting terminal.
31	DAOUT	O	Analog video signal output terminal (Current output).
32	DSOEN	I	Digital output (DSOUT7-DSOUT0) control terminal. H: Output possible, L: Output inhibit.
33	TEST1	I	Power supply leak test shifting terminal. H: Leak test mode, L: Normal mode.
34	DVSS		Digital system ground (A/D digital section).
35	DVDD		Digital system power supply (A/D digital section).
36	VRTS	O	A/D converter TOP side reference voltage supply.
37	VRT	I	A/D converter TOP side reference voltage input terminal.
38	AVDD		Analog system power supply (A/D analog section).
39	AVIN	I	Analog video signal input terminal.
40	AVSS		Analog system ground (A/D analog section).
41	VR9S	O	A/D converter BOTTOM side reference voltage supply.
42	VRB	I	A/D converter BOTTOM side reference voltage input terminal.
43	DSIN0	I	Digital video signal input terminal MSB: DSIN7
44	DSIN1		
45	DSIN2		
46	DSIN3		
47	DSIN4		
48	DSIN5		
49	DSIN6		
50	DSIN7		
51	DVDD		Digital system power supply (Logic section).
52	DVSS		Digital system ground (Logic section).
53	CNT2	I	Kick in-operation signal for PLL mode shifting. H: Line mode, L: Burst mode.
54	TOGGLE	I	Track cross signal at specific playback of CAV disc. Holds sub-carrier continuity by delaying video signal 2T.
55	NDOD	I	Drop out detection signal (Polarity : Negative).
56	HBI	O	PLL status flag, H: Burst mode, L: Line mode.
57	BSTOK	O	Burst amplitude detection output, H: Normal amplitude, L: Lesser amplitude.

Pin No.	Symbol	I/O	Function
58	CSYNC	I	Multiple sync signal input terminal (Polarity: Negative).
59	NCLPLS	O	Clamp pulse output, to sync-tip clamp video signal, (Polarity: Negative).
60	NODO	O	Even field/ odd field discrimination, H: Even field, L: Odd field.
61	NSPHD	O	HD for spindle servo.
62	WCK1	I	Write clock input, connect to WCK0.
63	WCK0	O	Write clock output.
64	WXO	O	WXI reversal amplifier output.
65	WXI	I	Input terminal of spurious component eliminated DTO output by ceramic filter.
66	TEST	I	SCAN PATH TEST shifting terminal, H: Scan Path Test mode, L: Normal mode.
67	DTO	O	Digital oscillator output of PLL.
68	NRST	I	Power ON reset signal (Polarity : Negative).
69	ATBC	O	Signal output for analog voice TBC.
70	X0	O	System clock terminal, connect X'tal (28.125MHz).
71	X1	I	X0 is X1 reversal amplifier output.
72	DVDD		Digital system power supply (Logic section).
73	DVSS		Digital system ground (Logic section).
74	MCLK	I	Microcomputer serial data transfer clock input.
75	MDATA	I	Microcomputer serial data input.
76	MLOAD	I	Microcomputer serial data load pulse input.
77	VTM	O	V timing signal for microcomputer, servo processor.
78	FLAG	O	Reference system operation flag. Returns reference shift, reference reset in-operation to microcomputer.
79	REFH	O	Spindle servo pull in reference signal (Polarity : Negative).
80	EXTREF	I	TBC pull in reference signal, used when applying reference signal from exterior (DSC).
81	TBCMTE	I	MUTE signal of TBC, Resets PLL loop filter, L: MUTE.
82	TBCHLD	I	HOLD signal of TBC, Holds loop filter status of PLL, L: HOLD.
83	PMOFF	I	Phase modulation OFF signal of read out clock, L: OFF.
84	ERON	I	PLL error data overlapped control signal. Overlaps φ M data to H sync when connecting MN8812, H: Data overlapped.

IC AN3891FBP (IC701)

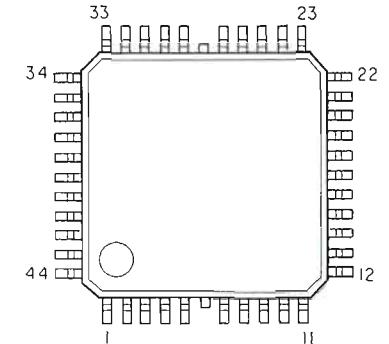

AN3891FBP Terminal Function

Pin No.	Symbol	Function
1	CS	Motor electric wave detection terminal.
2	PCV	Voltage feedback system phase compensation terminal.
3	PCI	Voltage feedback system phase compensation terminal.
4	GND	Grounding terminal.
5	GND	Grounding terminal.
6	NC	Not used.
7	GND	Grounding terminal.
8	GND	Grounding terminal.
9	AV	A/V shifting control signal terminal.
10	TL	Torque limit control signal terminal.
11	EC	Torque command signal input terminal.
12	ECR	Torque command signal reference terminal.
13	FGOUT	FG signal output terminal
14	FGIN	FG signal input terminal.
15	H1+	Hole element signal input terminal.
16	H1-	Hole element signal input terminal.
17	H2+	Hole element signal input terminal.
18	H2-	Hole element signal input terminal.
19	H3+	Hole element signal input terminal.
20	H3-	Hole element signal input terminal.
21	PCH	Hole AGC phase compensation terminal.
22	ED	Obverse / Reverse playback control signal terminal.
23	PC	Power cut control signal terminal.
24	BR	Generation break current setting terminal.
25	VCC	Power supply terminal.
26	GND	Grounding terminal.
27	GND	Grounding terminal.
28	NC	Not used.
29	GND	Grounding terminal.
30	GND	Grounding terminal.
31	ML1	Lower side predrive output 1.
32	ML2	Lower side predrive output 2.
33	ML3	Lower side predrive output 3.
34	MU3	Upper side predrive output 3.
35	MU2	Upper side predrive output 2.
36	MU1	Upper side predrive output 1.
37	M3	Motor coil voltage detection terminal 3.
38	M2	Motor coil voltage detection terminal 2.
39	M1	Motor coil voltage detection terminal 1.
40	SW	Switching power supply drive signal terminal.
41	SWG	Grounding terminal for switching drive.
42	PCS	Switching drive voltage feedback terminal.
43	FCR	External resistor terminal for sawtooth wave signal.
44	FCC	Capacitor terminal for sawtooth wave signal.

IC MN8812 (IC802)

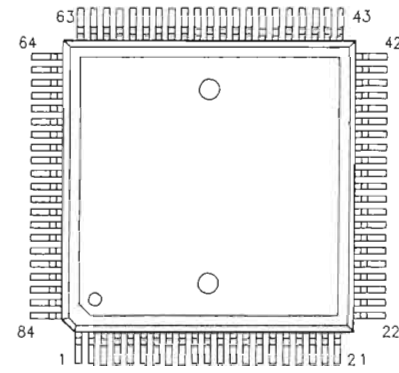

MN8812 Terminal Function

Pin No.	Symbol	I/O	Function
1	MV7	I	Video signal input from field memory. Binary8-bit MV7: MSB MV0: LSB
2	MV6		
3	MV5		
4	MV4		
5	MV3		
6	MV2		
7	MV1		
8	MV0		
9	HCL2	O	Video signal read out line control signal output of field memory.
10	INC2	O	Video signal read out increment signal output of field memory.
11	VCL2	O	Video signal read out start control signal output of field memory.
12	DVSS		Digital system ground (Logic section).
13	DVDD		Digital system power supply (Logic section).
14	OTSW	O	Read out mode detection output.
15	CPW	I	Write command control signal input of field memory. L: Write (Normal), H: Write stop
16	WRT	O	Write busy signal output, H: In writing.
17	MLOAD	I	Microcomputer serial data load pulse input.
18	MCLK	I	Microcomputer serial data transfer clock input.
19	MDATA	I	Microcomputer serial data input.
20	NRST	I	Power ON reset signal, L: Reset.
21	NDBK	I	Chroma-killer control input, H: Normal, L: No chroma.
22	NCV	O	Vertical sync output.
23	NCH	O	Horizontal sync output.
24	NBLACK	I	Black frame video signal control input, H: Normal, L: Sets to 01RE.
25	WHITE	I	White character video signal control input, H: Sets to 1001RE, L: Normal.
26	NHCSW	I	Horizontal sync replacing method selection signal, L: Pre-hold, H: Fixed value (02).
27	NPDSW	I	Phase detection operation selection signal, L: Stop, H: Operation (Normal).
28	FNRC	I	FNR operation selection signal, H: Stop, L: Operates by serial control.
29	TMODE	I	Test mode setting signal, H: Test mode, L: Normal.
30	TEST1	I	LSI test mode setting signal, L: Normal.
31	TEST	I	LSI scan bus test setting signal, L: Normal.
32	DVDD		Digital system power supply (D/A digital section).
33	DVSS		Digital system ground (D/A digital section).
34	VREF	I	D/A converter reference voltage setting terminal. (Reference voltage for full scale current adjustment).

Pin No.	Symbol	I/O	Function
35	IREF	I	D/A converter reference current setting resistor connecting terminal (Reference voltage for full scale current adjustment).
36	COMP	I	Capacitance connecting terminal for phase compensation.
37	VIB	I	Capacitance connecting terminal.
38	AVSS		Analog system ground (D/A analog section).
39	COUT	O	Analog chroma signal output terminal (Current output).
40	AVDD		Analog system power supply (D/A analog section).
41	YOUT	O	Analog brightness signal output terminal (Current output).
42	AVSS		Analog system ground (D/A analog section).
43	PMDATA	O	ϕ M data output.
44	NRV	I	Read out reference vertical sync signal input.
45	NRH	I	Read out reference horizontal sync signal input.
46	NWV	I	Video signal vertical sync signal input.
47	NWH	I	Video signal horizontal sync signal input.
48	VIN0	I	Digital video signal input terminal Binary MSB: VIN7 LSB: VIN0 Connect video signal output of MN8811.
49	VIN1		
50	VIN2		
51	VIN3		
52	VIN4		
53	VIN5		
54	VIN6		
55	VIN7		
56	DVSS		digital system ground (Logic section).
57	DVDD		Digital system power supply (Logic section).
58	CLK	I	Clock input terminal.
59	WVB	O	ϕ M data overlap control signal output, L: ϕ M inhibit.
60	HCL0	O	Field memory write line control signal.
61	INC0	O	Field memory write line increment signal.
62	VCL0	O	Field memory write start control signal.
63	WE	O	Field memory write control signal.
64	HCL1	O	Read out line control signal for FNR.
65	INC1	O	Increment signal for FNR.
66	VCL1	O	Read out start control signal for FNR.
67	MIV7	O	Video signal output to field memory Binary MSB: MIV7 LSB: MIV0
68	MIV6		
69	MIV5		
70	MIV4		
71	MIV3		
72	MIV2		
73	MIV1		
74	MIV0		
75	DVSS		Digital system ground (Logic section).
76	DVDD		Digital system power supply (Logic section).
77	MOFNR7	I	Video signal input for FNR. Binary MSB: MOFNR7 LSB: MOFNR0 Connect video signal output of field memory.
78	MOFNR6		
79	MOFNR5		
80	MOFNR4		
81	MOFNR3		
82	MOFNR2		
83	MOFNR1		
84	MOFNR0		

IC YVZ152-F (IC501)

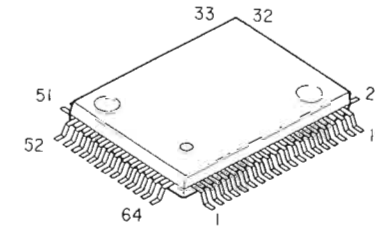

Block Diagram

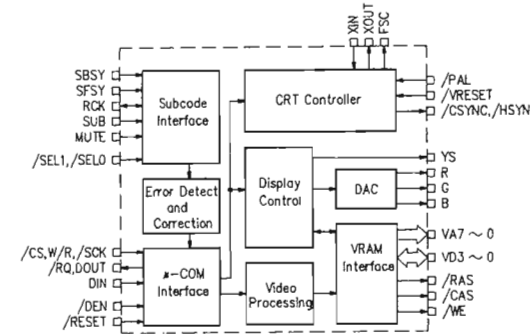

YVZ152-F Terminal Function

Pin No.	Name	I/O	Function
1	Vss	—	Ground (Digital).
2	/RESET	I	Reset input (Low active).
3	/RAS	O	DRAM Interface RAS.
4	/CAS	O	DRAM Interface CAS.
5	/WE	O	DRAM Interface WE.
6	VD0	I/O	DRAM Interface Data (LSB).
7	VD1	I/O	DRAM Interface Data.
8	VD2	I/O	DRAM Interface Data.
9	VD3	I/O	DRAM Interface Data (MSB).
10	VA0	I	DRAM Interface address (LSB).
11	VA1	I	DRAM Interface address.
12	VA2	I	DRAM Interface address.
13	VA3	I	DRAM Interface address.
14	VA4	I	DRAM Interface address.
15	VA5	I	DRAM Interface address.
16	VA6	I	DRAM Interface address.
17	VA7	I	DRAM Interface address (MSB).
18	/SELO	I+	Subcode Interface. Interface select.
19	/SEL1	I+	Subcode Interface. Interface select.
20	MUTE	I	Subcode Interface subcode data mute.
21	SUB	I	Subcode Interface subcode data.
22	RCK	I/O	Subcode Interface clock.
23	SFSY	I	Subcode Interface frame sync signal.
24	SBSY	I	Subcode Interface block sync signal.
25	/TEST0	I+	LSI test terminal (normally no connection).
26	V _{DD}	—	+5V power supply (digital).
27	/TEST1	I+	LSI test terminal (normally no connection).
28	/TEST2	I+	LSI test terminal (normally no connection).
29	DOUT	OT	μ -com Interface serial data output.
30	DIN	I	μ -com Interface serial data input.
31	/CS	I	μ -com interface chip select.
32	Vss	—	Ground (digital).
33	/SCK	I	μ -com interface serial clock input.
34	W/R	I	μ -com interface read/write select.
35	/RQ	O	μ -com interface subcode read request.
36	(NC)		
:			
49	(NC)		
50	YS	O	Superimpose timing output.
51	AV _{SS}	—	Ground (analog).
52	R	O	RGB Output (R).
53	G	O	RGB Output (G).
54	B	O	RGB Output (B).
55	AV _{DD}	—	+5V Power supply (analog).
56	/CSYNC	O	Composite synchro-signal output.
57	FSC	O	NTSC Subcarrier clock output (3.579545MHz).
58	V _{DD}	—	+5V Power supply (digital).
59	/VRESET	I+	Vertical timing reset input.
60	/HSYNC	O	Horizontal synchro-signal output.
61	/DEN	I+	Display enable ("L" ; data indication ON).
62	/PAL	I+	NTSC/PAL switching ("H" ; NTSC mode ; "L"=PAL mode).
63	XIN	I	X'tal oscillator connecting terminal or input of external clock (14.31818 MHz).
64	XOUT	O	X'tal oscillator connecting terminal.

NOTE) I+ : Input terminal with pull-up resistor.

OT: Explanation on try-state output terminal.

IC PA0034A (IC102)

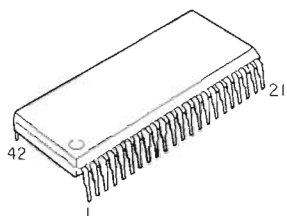

Block Diagram

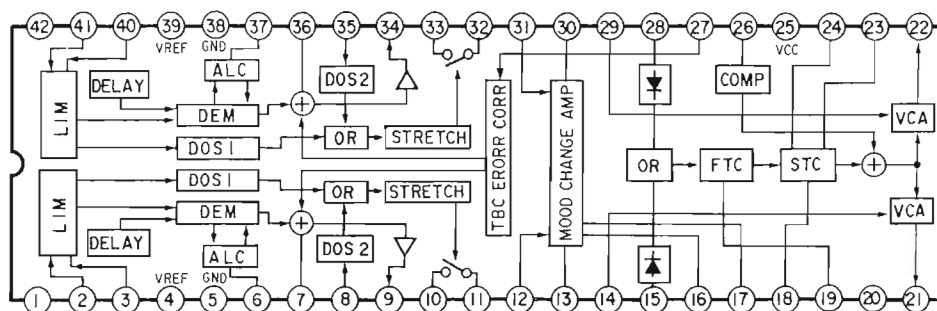

Terminal Function

Pin No.	Symbol	Function	Pin No.	Symbol	Function
1	VEER	-5V Power Supply Terminal.	22	LOUT	Lch output terminal.
2	VINR	Rch FM Signal input terminal. Inputs $f_c=2.8125\text{MHz}$ 100mVp-p.	23	STC2	Capacitor and resistor for STC is to be connected.
3	BIASR	Bias terminal for 2 pins.	24	STC1	Resistor for STC and capacitor for compensater is to be connected.
4	VREFR	Reference power supply terminal on Rch side. -2.2V type.	25	VDC	+5V Power supply terminal.
5	GNDR	0V Terminal	26	COMP	Input terminal for compensator.
6	ALCR	Capacitor for ALC circuit is to be connected.	27	TBC	Input terminal for TBC (Time base collector) error signal.
7	CSR	Delete carriers on Rch side by interior resistor of IC and external capacitor.	28	CINL	Input terminal to control CX. Output of 30 pin is input through external 500Hz HPF.
8	DOS2R	Terminal to detect drop out on Rch side. Noise components of around 200KHz out of demodulated output is input.	29	CXINL	Input terminal for CX-NR system. Output of 30 pin is input through capacitor.
9	DEMOR	Outputs audio signal demodulated on Rch side.	30	SWOL	Outputs signals after shifting of each mode.
10	SINR	Input terminal of switch which compensate drop out on Rch side. Output of 9 pin is input through capacitor.	31	SWINL	Input terminal of mode shifting amplifier. Output of 32 pin is input through external de-emphasis circuit.
11	DOCR	Outputs drop out demodulated signal. External capacity works as hold capacitor.	32	DOCL	Outputs drop out demodulated signals. External capacitor works as sample hold capacitor.
12	SWINR	Input terminal for mode shifting amplifier. Output of 11 pin is input through external de-emphasis circuit.	33	SINL	Input terminal for comensation switch of dropout on Lch. Output of 34pin is input through capacitor.
13	SWOR	Outputs signals after shifting each mode, such as STEREO, MONO, etc.	34	DEMOL	Outputs FM demodulated Lch audio signals.
14	CXINR	Input terminal of CX-NR system on Rch side.	35	DOS2L	Input terminal to detect drop out on Lch. Noise components of around 200 kHz out of demodulated output is input.
15	CIER	Input terminal of CX control signal. Inputs through 500Hz HPF.	36	CSL	Delete carrier (2.3011 MHz) on Lch by interior resistor of IC and external capacitor.
16	\bar{R}	Mode shifting terminal. TTL level.	37	ALCL	Capacitor for ALC circuit is to be connected.
17	\bar{L}	Mode shifting terminal. TTL level.	38	GNDL	0V Terminal.
18	\bar{CX}	Control terminal of ON/OFF of CX-NR system. TTL level.	39	VREFL	Reference power supply terminal of DEMO (Lch side.) (generated inside IC -2.2V type.)
19	FTC	Connect capacitor for FTC.	40	BIASL	Bias terminal of 41 pin.
20	GNDCX	GND terminal on CX side.	41	VINL	Input terminal of Lch FM signal. Input $f_c=2.3011\text{MHz}$ 100mVpp.
21	ROUT	Rch output terminal.	42	VEEL	-5V Power supply terminal.

IC SM5841AS (IC602)

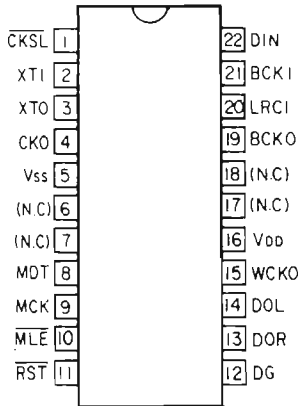
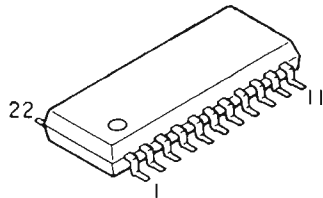

Block Diagram

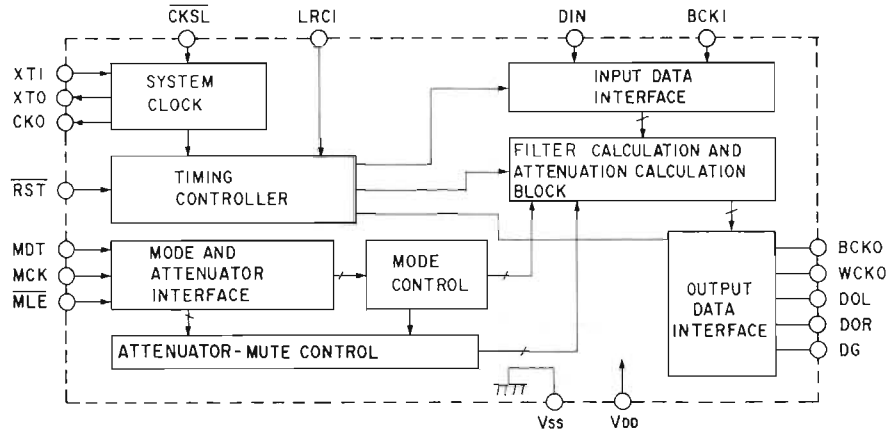

SM5841AS Terminal Function

Pin No.		Symbol	I/O	Function
DIP	SOP			
1	1	CKSL	IP	Oscillation and input frequency selection. (384fs at CKSL = H) (256fs at CKSL = L)
2	2	XTI	I	Oscillation section input terminal. (Selects frequency by CKSL)
3	3	XTO	O	Oscillation section output terminal.
4	4	CKO	O	Oscillation section output clock (Frequency is same as XTI terminal).
5	5	Vss	—	GND terminal.
—	6	NC	—	
—	7	NC	—	
6	8	MDT	IP	Mode set data. Mode set clock. Mode set latch enable. Performs setting of digital attenuator and mode flag register.
7	9	MCK	IP	
8	10	MLE	IP	
9	11	RST	IP	System reset (Initialize).
10	12	DG	O	Deglintch output: At 8fs LR parallel output mode. Deglintch output: At 4fs LR alternate output mode.
11	13	DOR	O	Rch data output: At 8fs LR parallel output mode. LR clock output: At 4fs LR alternate output mode.
12	14	DOL	O	Lch data output: At 8fs LR parallel output mode. LR data output: At 4fs LR alternate output mode.
13	15	WCKO	O	Output word clock.
14	16	VDD	—	Power supply terminal (5V: standard).
—	17	NC	—	
—	18	NC	—	
15	19	BCKO	O	Output bit clock.
16	20	LRCI	IP	Sample rate (fs) clock of input data.
17	21	BCKI	IP	Input bit clock.
18	22	DIN	IP	Input data.

I: Input Terminal IP: Input Terminal with pullup resistor. O: Output Terminal

IC HG62E33R79FS (IC603)

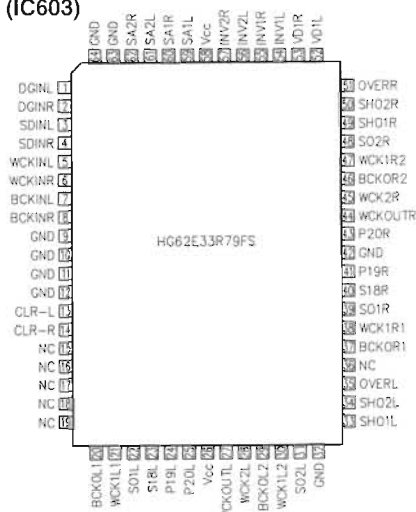

HG62E33R79FS Terminal Function

Pin No.	Symbol	I/O	Function
1	DGIN-L	I	Lch DG input.
2	DGIN-R	I	Rch DG input.
3	SDIN-L	I	Lch DATA input.
4	SDIN-R	I	Rch DATA input.
5	WCKIN-L	I	Lch WCK input.
6	WCKIN-R	I	Rch WCK input.
7	BCKIN-L	I	Lch BCK input.
8	BCKIN-R	I	Rch BCK input.
9	(GND)	I	—
10	(GND)	I	—
11	(GND)	I	—
12	(GND)	I	—
13	CLR-L	I	Lch reset input.
14	CLR-R	I	Rch reset input.
15	NC	—	—
16	NC	—	—
17	NC	—	—
18	NC	—	—
19	NC	—	—
20	BCKO-L1	O	Lch BCK output.
21	WCKO-L1	O	Lch WCK output at S18-L use.
22	S01-L	O	Lch 20 bit DATA (± 9 bit) output.
23	S18-L	O	Lch 18 bit DATA output (± 9 bit alternate output).
24	P19-L	O	Lch 19 bit parallel output (for current adding).
25	P20-L	O	Lch 20 bit parallel output (for current adding).
26	(Vcc)	I	—
27	WCKO-L	O	Lch WCK reverse output.
28	WCKO-L2	O	Lch current adding output for ± 9 bit compensation at S18-L use.
29	BCKO-L2	O	Lch BCK output. Same as Pin 20.
30	WCKO-L2	O	Lch WCK output at S18-L use. Same as Pin 21.
31	S02-L	O	Lch 20 bit DATA (± 9 bit) output.
32	(GND)	I	—
33	SH-01L	O	Lch DG output.
34	SH-02L	O	Lch DG reverse output.
35	OVER-L	O	Lch current adding output at OVER.
36	NC	—	—
37	BCKO-R1	O	Rch BCK output.
38	WCKO-R1	O	Rch WCK output at S18-R use.
39	S01-R	O	Rch 20 bit DATA (± 9 bit) output.
40	S18-R	O	Rch 18 bit DATA output (± 9 bit alternate output).
41	...		
64	NC	—	—

Remarks: Every Vcc and GND pins should be connected to the system's Vcc, GND.

IC MB81C1501 (IC803, 804)

(TOP VIEW)

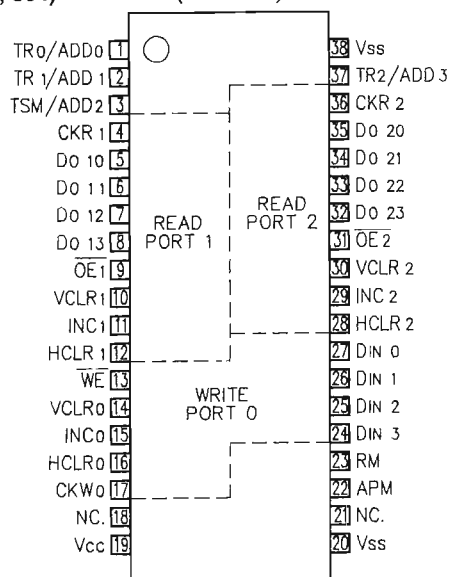

MB81C1501 Terminal Function

Pin No.	Symbol	I/O	Function
1	TR0/ADD0	I/O	Write port 0 : Transfer sync signal. or ADD0 address input.
2	TR1/ADD1	I/O	Read port 1 : Transfer sync signal. or ADD1 address input.
3	TSM/ADD2	I	Transfer sync mode enable, or ADD2 address input.
4	CKR1	I	Port 1 : shift signal.
5	DO10	O	Port 1 : Data output.
6	DO11		
7	DO12		
8	DO13		
9	OE1	I	Port 1 : Output enable.
10	VCLR1	I	Port 1 : Vertical clear signal.
11	INC1	I	Port 1 : Line increment signal.
12	HCLR1	I	Port 1 : Horizontal clear signal.
13	WE	I	Port 0 : Write Enable.
14	VCLR0	I	Port 0 : Vertical clear signal.
15	INC0	I	Port 0 : Line increment signal.
16	HCLR0	I	Port 0 : Horizontal clear signal.
17	CKW0	I	Port 0 : Shift signal.
18	NC	—	No Connection.
19	Vcc	—	Power supply (+5V).
20	Vss	—	Power supply (0V).
21	NC	—	No Connection.
22	APM	I	Address preset mode enable.
23	RM	I	Recursive mode enable.
24	DIN3	I	Port 0 : Data input.
25	DIN2		
26	DIN1		
27	DIN0		
28	HCLR2	I	Port 2 : Horizontal clear signal.
29	INC2	I	Port 2 : Line increment signal.
30	VCLR2	I	Port 2 : Vertical clear signal.
31	OE2	I	Port 2 : Output Enable.
32	DO23	O	Port 2 : Data output.
33	DO22		
34	DO21		
35	DO20		
36	CKR2	I	Port 2 : Shift Signal.
37	TR2/ADD3	I/O	Read port 2 : Transfer sync signal. or ADD3 address input.
38	Vss	—	Power supply (0V).

IC MN187324GD (IC901)

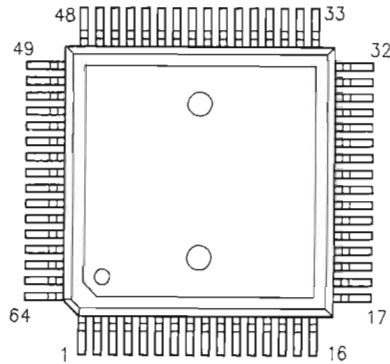

MN187324XGD Terminal Function

Pin No.	Symbol	I/O	Active	Name	Function
1	P56	O	H	seg6	FL display segment signal.
2	P55	O	H	seg5	FL display segment signal.
3	P54	O	H	seg4	FL display segment signal.
4	P53	O	H	seg3	FL display segment signal.
5	P52	O	H	seg2	FL display segment signal.
6	P51	O	H	seg1	FL display segment signal.
7	P50	O	H	seg0	FL display segment signal.
8	Vpp	—	—	Vpp	Pull down voltage input for high tension voltage output.
9	Vdd	—	—	Vdd	5V power supply.
10	OSC2	I	—	OSC2	Clock input.
11	OSC1	O	—	OSC1	Clock output.
12	Vss	—	—	Vss	Ground.
13	XI	I	—	XI	Not used.
14	XO	O	—	XO	Not used.
15	P27	I	L	C4	Shuttle C-4, becomes Low when turned ON.
16	P26	I	L	C3	Shuttle C-3, becomes Low when turned ON.
17	P25	I	L	C2	Shuttle C-2, becomes Low when turned ON.
18	P24	I	L	C1	Shuttle C-1, becomes Low when turned ON.
19	P23	I	L	MACK	Mechanism control acknowledge.
20	P22	O	L	OACK	Operation control acknowledge.
21	P21	I	L	J1	Jog J1, turned ON to Low.
22	P20	I	H	BLKCLK	Block signal (from Pin 39 of MN6626 EIMDSP).
23	P15	I	H	R. Data	Remote command reception data.
24	P14	I	H	VTM	Vertical sync signal.
25	P13	O	L	SCS	Chip selector.
26	P12	I	L	J2	Jog J2, becomes Low when turned ON.
27	P11	O	H	OE	Not used.
28	P10	O	H	CK-L	Not used.
29	P07	I	L	μRST	Microcomputer reset.
30	P05	O	H	SCLK	Serial clock signal.
31	P04	O	—	N. C.	Not used.
32	P03	O	H	A	SBOI serial data.

Pin No.	Symbol	I/O	Active	Name	Function
33	P02	O	—	μCLK	SBTO serial data signal.
34	P01	I	L	μSTTS	Serial input data signal.
35	P01	O	L	μCKD	Serial output data signal.
36	P01	O	—	SYNC	32768 divided clock output of Pin11.
37	CM	I	L	CM	Chip mode selection terminal.
38	P47	I	H	P47	Key scan input.
39	P46	I	H	P48	Key scan input.
40	P45	I	H	P45	Key scan input.
41	P44	—	—		Not used.
42	P43	O	H	pcLED	Picture quality control LED display.
43	P42	—	—		Not used.
44	P41	I	H	PWBCHK	PWB check mode, becomes check mode when turned to High.
45	P40	I	H	P0	Key scan input.
46	P87	O	H	DGT0	Grid 1 of FL.
47	P86	O	H	DGT1	Grid 2 of FL.
48	P85	O	H	DGT2	Grid 3 of FL.
49	P84	O	H	DGT3	Grid 4 of FL.
50	P83	O	H	DGT4	Grid 5 of FL.
51	P82	O	H	DGT5	Grid 6 of FL.
52	P81	O	H	DGT6	Grid 7 of FL.
53	P80	O	H	DGT7	Grid 8 of FL.
54	P71	O	H	DGT8	Grid 9 of FL.
55	P70	O	H	DGT9	Grid 10 of FL.
56	P67	O	H	SEG15	FL display segment signal.
57	P66	O	H	SEG14	FL display segment signal.
58	P65	O	H	SEG13	FL display segment signal.
59	P64	O	H	SEG12	FL display segment signal.
60	P63	O	H	SEG11	FL display segment signal.
61	P62	O	H	SEG10	FL display segment signal.
62	P61	O	H	SEG9	FL display segment signal.
63	P60	O	H	SEG8	FL display segment signal.
64	P57	O	H	SEG7	FL display segment signal.

Note: No connect terminal when using input or output port set output mode in Low level.

IC MB88327 (IC402)

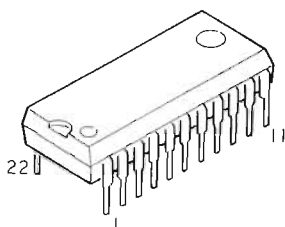

IC AN2661KN (IC401)

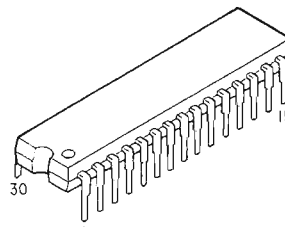

MB88327 Terminal Function

Pin No.	Symbol	I/O	Function
1	Test1	O	Chip test terminal. Normally open. Can also be used for dot clock, color burst clock oscillation frequency adjustment.
2	Test2	O	As long as test command not generates, stays in low level output.
3	VOC	O	Character signal output terminal.
4	VOB	O	Frame or background signal output terminal.
5	CMP/ HSYNC	I	Composite sync signal or horizontal sync signal input terminal. CTL terminal controls input signal selection. Hysteresis input.
6	VSYNC	I	Vertical sync signal input terminal. Hysteresis input.
7	Xnc	O	External circuit terminal of color burst clock generator (7.15909MHz).
8	EXnc	I	Composes X'tal oscillation circuit by connecting external X'tal oscillator and additional capacitance. Used for internal sync signal generation of video mode 2.
9	X	O	Composes IC oscillation circuit by externally connecting L and C.
10	EX	I	External circuit terminal of dot clock generator.
11	Vss	—	GND Terminal.
12	VOM	O	Composite signal output terminal of video signal, character signal, frame or background signal (Analog output).
13	(NC)	—	Not used.
14	VIN	I	Video signal input terminal (Analog input). Input 2Vp-p video signal which was applied DC restoration (DC clamp).
15	CTL	I	Selection control terminal of CMP/HSYNC terminal input signal. Inputs high level when selecting composite sync signal input, inputs low level when selecting horizontal sync signal input. In case selected composite sync signal input, vertical sync signal input is defied, but be sure and not to make VSYNC terminal in unstable level.
16	AVcc	—	+5V external power supply terminal for analog output.
17	SI	I	Display controlling serial data input terminal. Hysteresis input.
18	SCLK	I	Serial transferring shift clock input terminal. Hysteresis input.
19	CS	I	Chip select terminal. Set to low level for serial transfer. By making this terminal in low level, initializing of 8-bit serial transfer is performed. Hysteresis input.
20	CB	I	Controls color burst signal, color signal when used video mode 2. When this terminal is in high level at video mode 2, blue background shows irrespective of internal register setting (No block and white picture shows).
21	Reset	I (I/O)	TVDC reset input terminal, and with Reset low level, TVDC operation is initialized. In case power ON without reset (MB88327-K1), after oscillation becomes stable at a time of power ON, hold low level more than 10us. Generally, composing a power ON reset circuit by external CR. In case with power ON reset, this terminal acts as in/out terminal. Emits low level output by detecting power supply rise at power ON. To release this power ON reset, requires applying of vertical sync signal (VSYNC signal) at power ON. Hysteresis input.
22	Vss	—	+5V external power supply terminal.

AN2661KN Terminal Function

Pin No.	Function
1	Vref output.
2	Noise cancel output.
3	Vcc1 (VIDEO).
4	Switch control.
5	External video input.
6	GND1 (VIDEO).
7	Fade control.
8	Video output.
9	Noise cancel control.
10	Noise cancel Low input.
11	Noise cancel High input.
12	Pedestal level hold.
13	Code separation output.
14	Sync separation output.
15	Drop out output.
16	Vcc2 (FM).
17	DO compensation input (normal).
18	Deemphasis output.
19	Deemphasis input.
20	FM demodulation control.
21	FM demodulation output.
22	DO High control.
23	FM demodulation capacitance connection terminal.
24	FM demodulation capacitance connection terminal.
25	DO Low control.
26	FM demodulation input.
27	DO Amp control.
28	DO compensation input (1HD).
29	GND2 (FM).
30	DO compensation output.

IC AN8831SC (IC002)

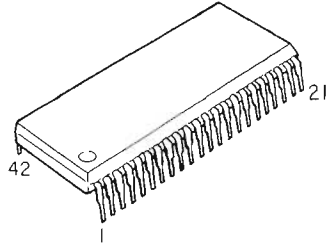

AN8831SC Terminal Function

Pin No.	Function
1	Power supply (1) -1V.
2	APC input terminal.
3	APC output terminal.
4	TILT + input terminal.
5	TILT - input terminal.
6	GND (1) terminal 0V.
7	GND (2) terminal 0V.
8	RFLOW output terminal.
9	RFOUT input terminal.
10	RFOUT output terminal.
11	EFMAGC control Output terminal.
12	EFMAGC input terminal.
13	EFMAGC output terminal.
14	RFAGC control output terminal.
15	RFAGC input terminal.
16	RFAGC output terminal.
17	BDO detect output terminal.
18	OFTR detect output terminal.
19	Power supply (2) 5V
20	CROSS output terminal.
21	OFTR Output terminal.
22	Reference power supply (1) 4V.
23	Reference power supply (2) 2.5V.
24	Reference power supply (3) 1V.
25	Power supply (3) 5V.
26	RFenvB output terminal.
27	RFp-p Output terminal.
28	TILT + output terminal.
29	TILT - Output terminal.
30	Tracking error output terminal.
31	Focus error output terminal.
32	TILT balance input terminal.
33	Tracking balance input terminal.
34	Focus balance input terminal.
35	BDO output terminal.
36	CROSS input terminal.
37	Tracking error input terminal (1).
38	Tracking error input terminal (2).
39	Focus error input terminal (1).
40	Focus error input terminal (2).
41	A-V switch input terminal.
42	APC switch input terminal.

IC MN1883210XGC (IC301)

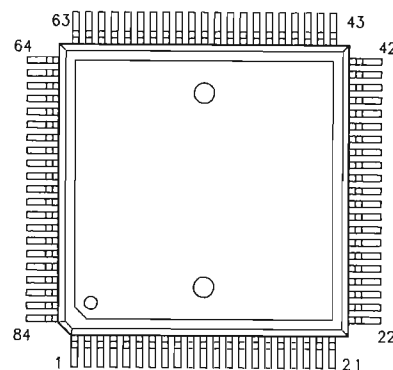

MN1883210XGC Terminal Function

Pin No.	Port Name	I/O	Active	Symbol	Function
1	P65	O	L	POWER	Secondary power supply, H: OFF, L: ON.
2	P64	I	H	DEMPH	Deemphasis input, H: ON, L: OFF.
3	P63	I	H	WRT	F-memory write status, H: In-writing, L: Other.
4	P62	O	L	CPW	F-memory write control, H: Write inhibit, L: Permit.
5	P61	O	L	PMOFF	ϕ M, H: OFF, L: ON.
6	P60	O	L	TBCMUTE	TBC mute, H: OFF, L: ON.
7	P57	O		NDBX	Chroma, H: Normal, L: Mono tone.
8	P56	O		YDOWN	Brightness, H: Normal, L: Down.
9	P55	O		EPRDY	AK6420F(EEPROM) control signal READY.
10	P54	O		EPRST	Reset
11	P53	O		EPLOAD	CS
12	P52	O		EPCLK	Clock
13	P51	I		EPIN	Data input
14	P50	O		EPOUT	Data output
15	EXT	I		GND	Microcomputer operation mode.
16	RST	I	L	RST	Microcomputer reset.
17	P47	I		TL4	Test input for microcomputer live load checking.
18	P46	I	L	MODE	Adjustment mode, H: Normal, L: Adjustment mode.
19	P45	I	↓	CDGREQ	CDG data take in request.
20	P44	O		CDG/LD	CDG/LD video signal shifting, H: CDG, L: LD.
21	P43	I	L	HKILL	Horizontal sync signal stop, H: OK, L: Kill.
22	P42	O		MTF	Frequency characteristic of MTF-amplifier, H: CLV outer circle playback, L: Others.
23	P41	O		A/V	Digital voice RF selection, H: At CD playback, L: Others.
24	P42	O		20/30	Spindle torque, H: Torque does not down at 30cm LD and CD playback, L: Torque down at playback other than the above.
25	IRQ2	I		BLKCK	Subcode block clock signal.
26	IRQ1	I	↑	VTM	Vertical sync signal for microcomputer.
27	IRQ0	I	↓	DTGATE	24-bit code read out timing signal.
28	P22	I		HBI	PLL status, H: Fine system, L: Coarse system.
29	TCI02	I		FG/N	FG signal.
30	P20	I		CGVS	Vertical sync signal for character generator.
31	OSC2				Microcomputer oscillation output.
32	OSC1				Microcomputer oscillation input.
33	VSS			GND	
34	XI			GND	Slow-speed oscillation input.
35	XO			NC	Slow-speed oscillation output.
36	P17	O	H	LOAD	Loading, H: Tray, L: Tilt.
37	P16	O	L	CDGCS	CDG IC (YVZ152) CS signal.

Pin No.	Port Name	I/O	Active	Symbol	Function
38	P15	O	H	CDGMUTE	CDG subcode mute, H: ON, L: OFF.
39	P14	O	L	CKGRST	CDG IC (YVZ152) reset signal.
40	P13	I		TRAY-A	Tray position detection switch.
41	P12	I		TRAY-B	Tray position detection switch.
42	P11	I		TRAY-C	Tray position detection switch.
43	P10	I		TRAY-D	Tray position detection switch.
44	P33	I		SENSE4	Servo status.
45	P32	I		SENSE3	Servo status.
46	P31	I		SENSE2	Servo status.
47	P30	I		SENSE1	Servo status.
48	SBT0	I	L	μ CLK	Microcomputer communication clock.
49	SB10	I	L	μ CMD	Microcomputer communication data input.
50	SBO0	O	L	μ STTS	Microcomputer communication data output.
51	NC			NC	
52	SBT1	O	L	MCLOCK	Communication with circumference LSI, clock.
53	SB11	I	L	SDATA	Communication with circumference LSI, 24-bit/subcode, CDG data input.
54	SBO1	O	L	MDATA	Communication with circumference LSI, data output.
55	P94	O		MLOAD	Communication with circumference LSI, strobe.
56	P93	I	H	MREADY	MN66601 command reception status, H: Transmit permit, L: Inhibit.
57	P92	O	H	ENSUB	Data get read out shifting, H: subcode.
58	P91	O	H	EN24B	Data get read out shifting, H: 24-bit code.
59	P90	O		SEARCH	24-bit code read out mode, H: Within \pm 30%, L: Within \pm 5%.
60	AVSS			GND	Power supply for A/D, D/A.
61	SH			NC	Sample hold terminal for A/D.
62	VREF-			GND	Reference power supply for A/D, D/A.
63	P87	I		TRVS-A	Traverse position detection switch.
64	P86	I		TRVS-B	Traverse position detection switch.
65	P85	I		TRVS-C	Traverse position detection switch.
66	P84	I		TRVS-D	Traverse position detection switch.
67	P83			NC	
68	P82	I		STAT	MN626 status signal (select by microcomputer). CRC: CRC operational result of subcode, H: OK, L: NG. CLVS: Spindle servo phase sync status, H: CLV, L: 11T.
69	P81		L	FLAG	MN8811 status signal (select by microcomputer). Compensation operation: H: Compensation in-operation, L: Compensation operation finish. Reference shift: Reference shift flag = at H. H: In reference shift, L: before start reference shift. Reference shift flag = at L. H: Reference shift unfinished, L: Reference shift finished.
70	P80	I		NODD	Field, H: Even, L: Odd.
71	VREF+			+5V	Reference power supply for A/D, D/A.
72	AVDD			+5V	Power supply for A/D, D/A.
73	VDD			+5V	Power supply.
74	P77			NC	
75	P76	O	H	MEMPH	Emphasis for digital audio interface, H: ON, L: OFF.
76	P75	O	L	Lch	L/R shifting of voice, Stereo=Lch: L, Rch: L.
77	P74	O	L	Rch	Lch=Lch: L, Rch: H Rch=Lch: H, Rch: L.
78	P73	O	H	DMUTE	Digital voice mute, H: ON, L: OFF.
79	P72	O	L	CX	CX output, H: OFF, L: ON.
80	P71	O		DIGITAL	Analog/digital shifting of voice, H: Analog voice, L: Digital voice.
81	P70	O	H	MUTE	Voice mute, H: ON, L: OFF.
82	VSS			GND	Power supply ground.
83	P67	O		MACK	Microcomputer communication, mechanism control acknowledge.
84	P66	O		OACK	Microcomputer communication, operation control acknowledge.

● IC's

TC74HCU04AF (IC614)

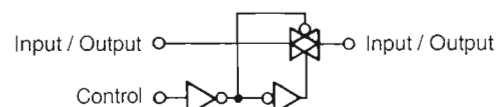
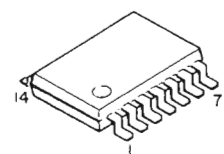

Block Diagram

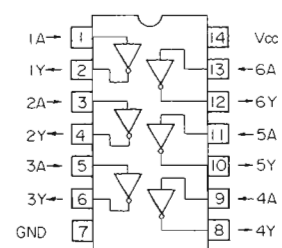

MN73091PXJ (IC304)

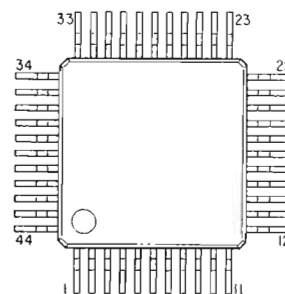

Block Diagram

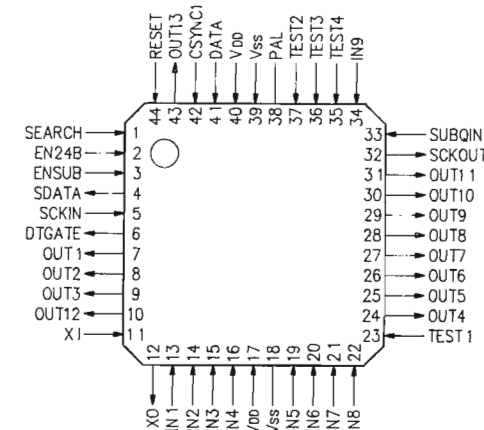

M6M80011AP (IC305)

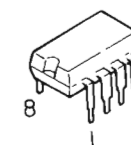

HD14053BFP (IC103, 404, 608, 609, 611, 655, 656, 805)

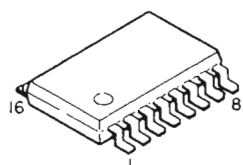

Block Diagram

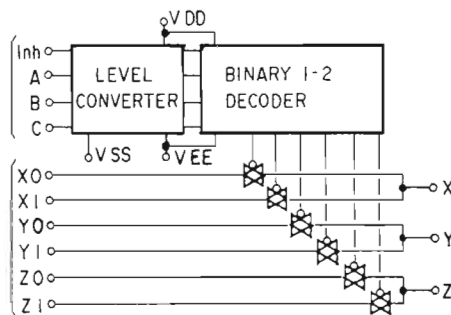
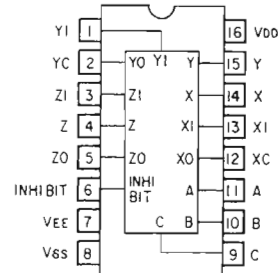

TC4053BF (IC805)

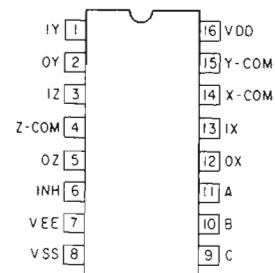
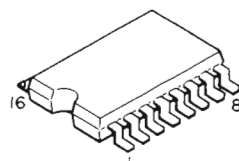

LA-6510 (IC101, 104)

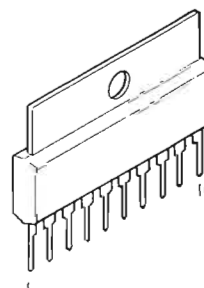

Block Diagram

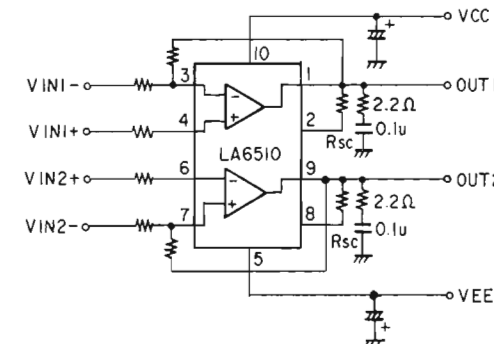

NJM7805FA(S) (IC704, 705, 707)
NJM7809FA(S) (IC702)

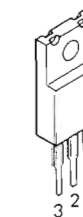

1 : Output
2 : GND
3 : Input

NJM4556MB (IC951)

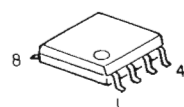

Block Diagram

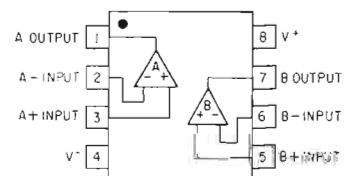

MN1280S (IC303)

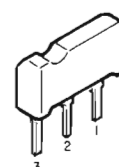

1 : Output
2 : VDD
3 : VSS

Block Diagram

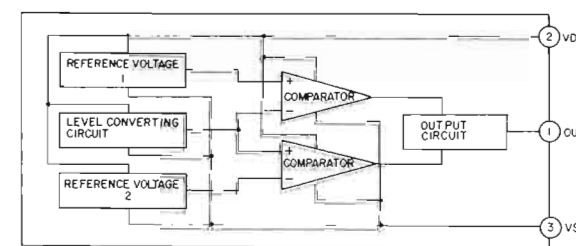

NJM7905FA (IC708)
NJM7909FA (IC703)



1 : Output
2 : Input
3 : GND

BA10393F (IC006)
BA4558F (IC003, 004, 102, 606, 607, 610, 612, 613)

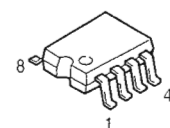

Block Diagram

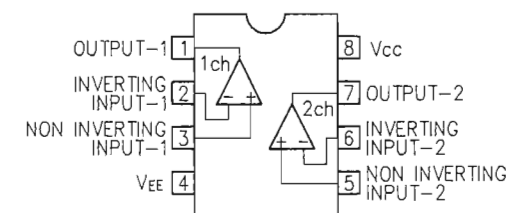

● IC Protector
ICP-N15T (IC111, 112, 113, 114)

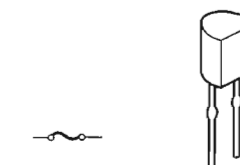

(N Type)

LM33464G-12 (IC502)

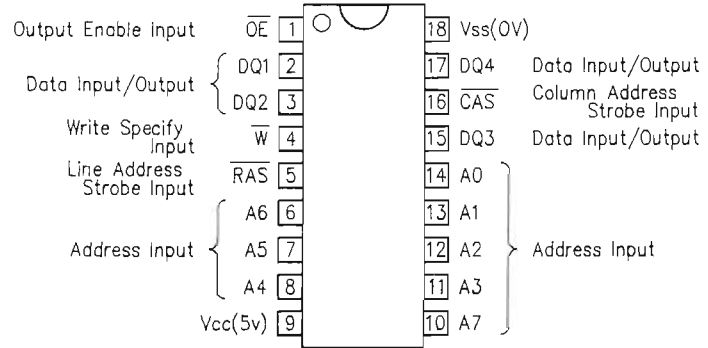
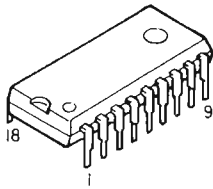

PCM61P (IC604,605)

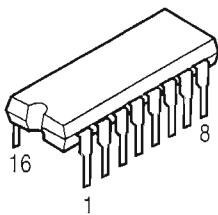

Block Diagram

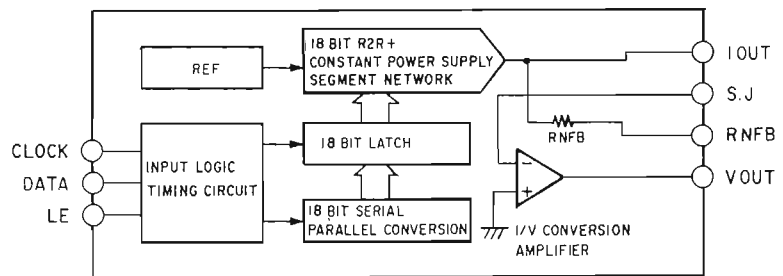

M51957A, B (IC302)

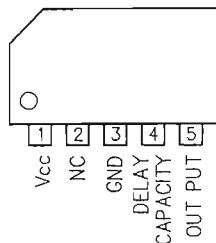
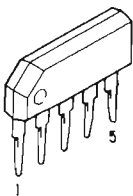

Block Diagram

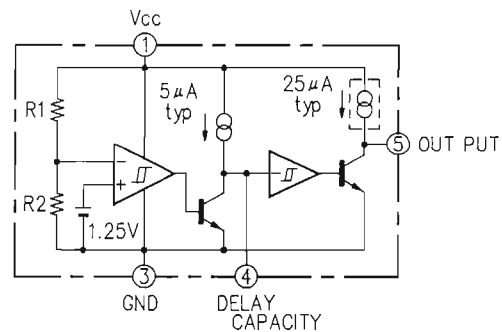

SBX1610-52 (IC903)
Remote Control Receiver

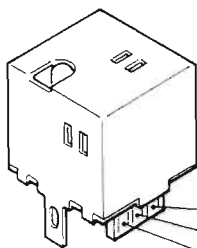

1: GND
2: Vout
3: Vcc

Block Diagram

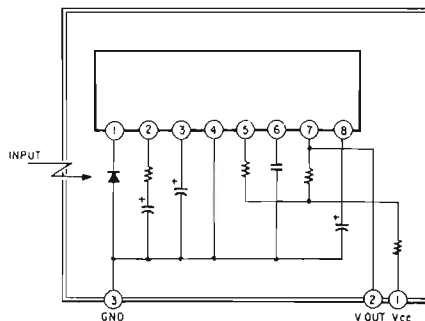

● Transistor

Digital Transistor

2SC2295 UN2211 UN2112
 2SB709A UN2212 UN2113
 2SB601A UN2213 UN2115
 2SD1306 UN2111 UN2116

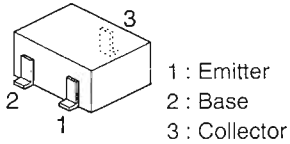

Equivalent Circuit
 UN2211, UN2111

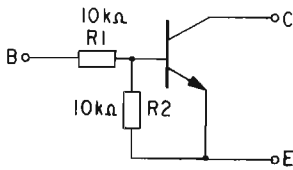

UN2212, UN2112, UN2115

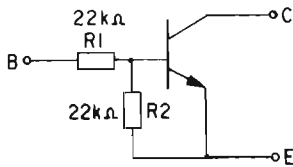

UN2213, UN2113

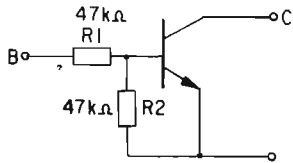

2SC1384

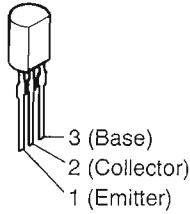

2SA1488A
 2SA1567
 2SC3851A

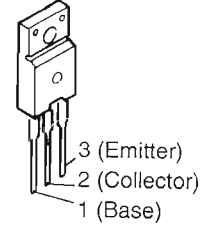

2SA933 (Q),(R/S)

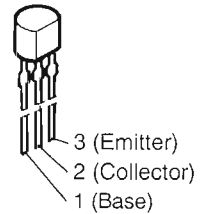

2SC1847

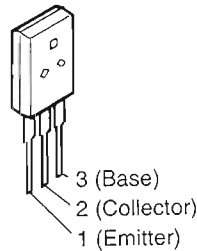

2SJ164

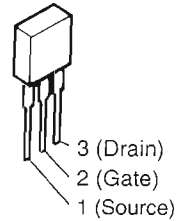

DTC114TS

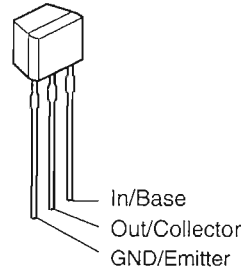

DTCTS Series

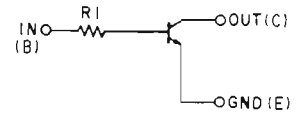

	R1
DTC114TS	10kohm

● Diode (including LED)

1SS270A

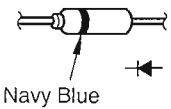

1SR35-200A
 HZS-30-1
 HZS-7C-1

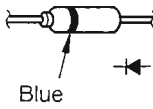

1SS198

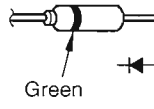

SEL-1410G (Green)

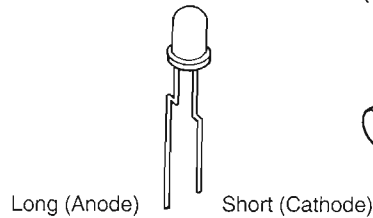

● Fuse

1.6A (F701, 702, 703)
 2.0A (F704, 705)

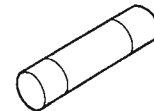

Vari-cap Diode
 FC54M

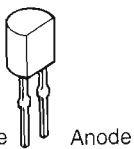

RL2Z

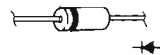

S1WB(A)10



S2VB20

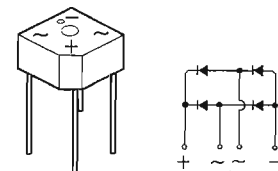

FIP7BCM8 (FL901)

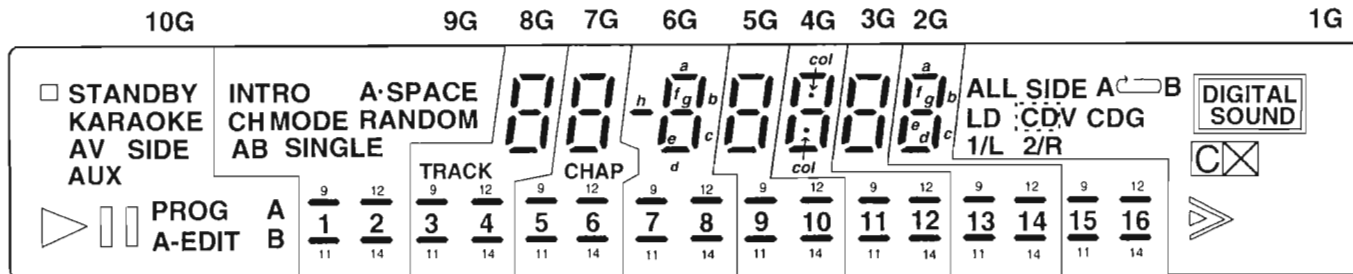

Internal Connection Table

	10G	9G	8G	7G	6G	5G	4G	3G	2G	1G
SO	■	INTRO	a	a	a	a	a	a	a	ALL
S1	STNDBY	SINGLE	b	b	b	b	b	b	b	SIDE
S2	SIDE	RANDOM	c	c	c	c	c	c	c	A
S3	AV	A	d	d	d	d	d	d	d	↻
S4	PROG	B	e	e	e	e	e	e	e	B
S5	-	CH-MODE	f	f	f	f	f	f	f	DIGITAL SOUND
S6	-	-	g	g	g	g	g	g	g	1/L
S7	-	-	-	-	h	-	col	-	-	2/R
S9	KARAOKE	A-SPACE	TRACK	CHAP	-	-	-	-	-	LD
S10	AUX	9(UP)	9(")	9(")	9(")	9(")	9(")	9(")	9(")	CD
S11	▶	1	3	5	7	9	11	13	15	V
S12	▢▢	11(DOWN)	11(")	11(")	11(")	11(")	11(")	11(")	11(")	CDG
S13	A-EDIT	12(UP)	12(")	12(")	12(")	12(")	12(")	12(")	12(")	⊗
S14	A	2	4	6	8	10	12	14	16	>
S15	B	14(DOWN)	14(")	14(")	14(")	14(")	14(")	14(")	14(")	▶

Note: For some reasons, S8 is not existing.

(UPPER)

TERMINAL No.	104	103	102	101	100	99	98	97	96	95	94	93	92	91	90	89				
ELECTRODE	F2	F2	NC	NC	NC	NP	NP	NP	NP	NP	NP	NP	NP	NP	NP	NP				
TERMINAL No.	88	87	86	85	84	83	82	81	80	79	78	77	76	75	74	73	72	71	70	69
ELECTRODE	NP	NP	NP	NP	NP	NP	NP	NP	NP	NP	NP	NP	NP	NP	NP	NP	NP	NP	NP	NP
TERMINAL No.					68	67	66	65	64	63	62	61	60	59	58	57	56	55	54	53
ELECTRODE					NP	NP	NP	NP	NP	NP	NP	NP	NP	NP	NP	NP	NC	NC	NC	F2

(LOWER)

TERMINAL No.					37	38	39	40	41	42	43	44	45	46	47	48	49	50	51	52	
ELECTRODE					S12	S11	S10	S9	NC	S7	S6	S5	S4	S3	S2	S1	S0	NP	F2	F2	
TERMINAL No.	17	18	19	20	21	22	23	24	25	26	27	28	29	30	31	32	33	34	35	36	
ELECTRODE	NP	NP	NP	NP	NP	NP	NP	NP	NP	NP	NP	NP	NP	NP	NP	NP	NP	NP	S15	S14	S15
TERMINAL No.	1	2	3	4	5	6	7	8	9	10	11	12	13	14	15	16					
ELECTRODE	F1	F1	NP	1G	2G	3G	4G	5G	6G	7G	8G	9G	10G	NP	NP	NP					

Notes: F: Filament
G: Grid
P: Anode

NP: No-Pin
NC: No Connection

No 1, 2
No 51, 52
No 53, 54
No 55 - 57
No 100 - 102
No 103, 104

} Externally connected.

NOTE FOR PARTS LIST

- Part indicated with the mark "◎" are not always in stock and possibly to take a long period of time for supplying, or in some case supplying of part may be refused.
- When ordering of part, clearly indicate "1" and "I" (i) to avoid mis-supplying.
- Ordering part without stating its part number can not be supplied.
- Part indicated with the mark "★" is not illustrated in the exploded view.
- Not including Carbon Film ±5%, 1/4W Type in the P.W.Board parts list. (Refer to the Schematic Diagram for those parts.)

WARNING:

Parts marked with this symbol  have critical characteristics.
Use ONLY replacement parts recommended by the manufacturer.

● **Resistors**

Ex.: RN 14K 2E 182 G FR
 Type Shape and performance Power Resistance Allowable error Others

RD : Carbon	2B : 1/8W	F : ±1%	P : Pulse-resistant type
RC : Composition	2E : 1/4W	G : ±2%	NL : Low noise type
RS : Metal oxide film	2H : 1/2W	J : ±5%	NB : Non-burning type
RW : Winding	3A : 1W	K : ±10%	FR : Fuse-resistor
RN : Metal film	3D : 2W	M : ±20%	F : Lead wire forming
RK : Metal mixture	3F : 3W		
	3H : 5W		

* **Resistance**

1 8 2 ⇒ 1800 ohm = 1.8 kohm
 Indicates number of zeros after effective number.
 2-digit effective number.

• Units: ohm

1 R 2 ⇒ 1.2 ohm
 1-digit effective number.
 2-digit effective number, decimal point indicated by R.

• Units: ohm

● **Capacitors**

Ex.: CE 04W 1H 2R2 M BP
 Type Shape and performance Dielectric strength Capacity Allowable error Others

CE : Aluminum foil electrolytic	0J : 6.3V	F : ±1%	HS : High stability type
CA : Aluminum solid electrolytic	1A : 10V	G : ±2%	BP : Non-polar type
CS : Tantalum electrolytic	1C : 16V	J : ±5%	HR : Ripple-resistant type
CO : Film	1E : 25V	K : ±10%	DL : For charge and discharge
CK : Ceramic	1V : 35V	M : ±20%	HF : For assuring high frequency
CC : Ceramic	1H : 50V	Z : ±80%	U : UL part
CP : Oil	2A : 100V	-20%	C : CSA part
CM : Mica	2B : 125V	P : ±100%	W : UL-CSA type
CF : Metallized	2C : 160V	-0%	F : Lead wire forming
CH : Metallized	2D : 200V	C : ±0.25pF	
	2E : 250V	D : ±0.5pF	
	2H : 500V	= : Others	
	2J : 630V		

* **Capacity (electrolyte only)**

2 2 2 ⇒ 2200μF
 Indicates number of zeros after effective number.
 2-digit effective number.

• Units: μF.

2 R 2 ⇒ 2.2μF
 1-digit effective number.
 2-digit effective number, decimal point indicated by R.

• Units: μF.

* **Capacity (except electrolyte)**

2 2 2 ⇒ 2200pF = 0.0022μF
 (More than 2) — Indicates number of zeros after effective number.
 2-digit effective number.

• Units: μF.

2 2 1 ⇒ 220pF
 (0 or 1) — Indicates number of zeros after effective number.
 2-digit effective number.

• Units: pF.

• When the dielectric strength is indicated in AC, "AC" is included after the dielectric strength value.

P.W.B. ASS'Y PARTS LIST
2U-2570 MAIN UNIT

Ref. No.	Part No.	Part Name	Remarks	Ref. No.	Part No.	Part Name	Remarks
SEMICONDUCTORS GROUP				RESISTORS (Not included Carbon Film $\pm 5\%/1/4W$)			
IC001	262 1801 000	IC MN66601VRRD2		D001-005	276 0432 000	Diode 1SS270A	
IC002	263 0872 004	IC AN8831SC		D006	276 0503 900	Diode 1SS198	
IC003,004	263 0672 903	IC BA4558F		D201,202	276 0432 000	Diode 1SS270A	
IC006	263 0673 902	IC BA10393F		D301	276 0432 000	Diode 1SS270A	
IC101	263 0877 009	IC LA6510		D701	276 0432 000	Diode 1SS270A	
IC102	263 0672 903	IC BA4558F		D702-707	276 0519 004	Diode 1SR35-200A	
IC103	262 1211 904	IC HD14053BFP-TR		D708-712	276 0432 000	Diode 1SS270A	
IC104	263 0877 009	IC LA6510		D711,712	276 0432 000	Diode 1SS270A	
IC111-114	268 0073 905	IC 1CP-N15		D713	LA1 300K 191	Diode RL2Z	
IC201	263 0798 007	IC PA0034A		D723-725	276 0432 000	Diode 1SS270A	
IC301	262 1796 005	IC 1883210XGC		D726	276 0483 910	Zener Diode HZS30-2D	
IC302	263 0454 008	IC M51957B		D727	276 0466 908	Zener Diode HZS7C-1D	
IC303	262 0678 001	IC MN1280-S					
IC304	262 1802 009	IC MN73091PXJ					
IC305	262 1809 002	IC M6M80011AP					
IC701	263 0873 003	IC AN3891FBP					
IC702	263 0753 000	IC NJM7809FA(S)					
IC703	263 0878 008	IC NJM7909FA					
IC704,405	263 0809 006	IC NJM7805FA(S)					
IC708	263 0554 005	IC NJM7905FA					
TR001	271 0269 003	Transistor 2SA1309A		VR001,002	211 6064 006	Adjust 10kohm	V06PB103
TR002,003	272 0125 904	Transistor 2SB709A		R004-007	247 0009 901	Chip 4.7kohm 1/10W	RM73B--472J
TR004-006	928 0022 100	Transistor 2SC2295		R008,009	247 0009 082	Chip 10kohm 1/10W	RM73B--103J
TR007	928 0037 001	Transistor UN2213		R010	247 0009 901	Chip 4.7kohm 1/10W	RM73B--472J
TR009	928 0022 100	Transistor 2SC2295		R012	247 0010 903	Chip 12kohm 1/10W	RM73B--123J
TR010	271 0269 003	Transistor 2SA1309A		R013	247 0011 928	Chip 39kohm 1/10W	RM73B--393J
TR011,012	272 0125 904	Transistor 2SB709A		R014	247 0006 920	Chip 330ohm 1/10W	RM73B--331J
TR013,014	928 0037 001	Transistor UN2213		R015,016	247 0007 945	Chip 1kohm 1/10W	RM73B--102J
TR015	928 0024 409	Transistor UN2113		R017,018	247 0008 928	Chip 2.2kohm 1/10W	RM73B--222J
TR018	928 0024 205	Transistor UN2112		R019	247 0007 945	Chip 1kohm 1/10W	RM73B--102J
TR101	273 0393 001	Transistor 2SC3851A(Y)/(G)		R020	247 0004 906	Chip 39ohm 1/10W	RM73B--390J
TR102	271 0246 000	Transistor 2SA1488A(Y)/(G)		R022	247 0011 902	Chip 33kohm 1/10W	RM73B--333J
TR103	273 0393 001	Transistor 2SC3851A(Y)/(G)		R023	247 0010 945	Chip 18kohm 1/10W	RM73B--183J
TR104	271 0246 000	Transistor 2SA1488A(Y)/(G)		R024	247 0007 945	Chip 1kohm 1/10W	RM73B--102J
TR105	275 0073 903	Transistor 2SJ164PQJTP		R025	247 0006 920	Chip 330ohm 1/10W	RM73B--331J
TR106	269 0088 906	Transistor DTC114TK		R026	247 0006 904	Chip 270ohm 1/10W	RM73B--271J
TR201-203	928 0036 701	Transistor 2SD601A		R027	247 0004 964	Chip 68ohm 1/10W	RM73B--680J
TR301	928 0024 700	Transistor UN2215		R028	247 0006 988	Chip 560ohm 1/10W	RM73B--561J
TR302	928 0036 701	Transistor 2SD601A		R029	247 0007 903	Chip 680ohm 1/10W	RM73B--681J
TR701-703	273 0393 001	Transistor 2SC3851A(Y)/(G)		R031-033	247 0011 944	Chip 47kohm 1/10W	RM73B--473J
TR704-706	271 0246 000	Transistor 2SA1488A(Y)/(G)		R034,035	247 0009 082	Chip 10kohm 1/10W	RM73B--103J
TR707-709	273 0421 009	Transistor 2SC1384		R037	247 0009 082	Chip 10kohm 1/10W	RM73B--103J
TR710	273 0420 000	Transistor 2SC1847		R038,039	247 0009 969	Chip 8.2kohm 1/10W	RM73B--822J
TR711	271 0270 005	Transistor 2SA1567		R040,041	247 0009 927	Chip 5.6kohm 1/10W	RM73B--562J
TR712	271 0269 003	Transistor 2SA1309A		R042,043	247 0010 903	Chip 12kohm 1/10W	RM73B--123J
TR714,715	269 0137 909	Transistor UN2212		R044	247 0008 960	Chip 3.3kohm 1/10W	RM73B--332J
TR720	928 0026 601	Transistor UN2111		R048	247 0010 929	Chip 15kohm 1/10W	RM73B--153J
TR721	273 0393 001	Transistor 2SC3851A(Y)/(G)		R049	247 0011 928	Chip 39kohm 1/10W	RM73B--393J
TR722	928 0024 302	Transistor UN2211		R050	247 0010 084	Chip 27kohm 1/10W	RM73B--273J
TR724	271 0183 927	Transistor 2SA933(R/S)		R051	247 0009 082	Chip 10kohm 1/10W	RM73B--103J
TR725	273 0393 001	Transistor 2SC3851A(Y)/(G)		R052	247 0005 989	Chip 220ohm 1/10W	RM73B--221J
TR726	928 0026 601	Transistor UN2111		R053	247 0004 964	Chip 68ohm 1/10W	RM73B--680J
TR727,728	928 0024 302	Transistor UN2211		R054	247 0007 945	Chip 1kohm 1/10W	RM73B--102J
TR729,730	271 0246 000	Transistor 2SA1488A(Y)/(G)		R055,056	247 0010 961	Chip 22kohm 1/10W	RM73B--223J
TR731	928 0024 302	Transistor UN2211		R059	247 0012 927	Chip 100kohm 1/10W	RM73B--104J
				R060	247 0010 945	Chip 18kohm 1/10W	RM73B--183J
				R061	247 0007 961	Chip 1.2kohm 1/10W	RM73B--122J
				R062	247 0009 082	Chip 10kohm 1/10W	RM73B--103J
				R063	247 0009 901	Chip 4.7kohm 1/10W	RM73B--472J
				R064	247 0002 940	Chip 8.2ohm 1/10W	RM73B--8R2K

Ref. No.	Part No.	Part Name	Remarks
R065	247 0006 920	Chip 330ohm 1/10W	RM73B-331J
R073	247 0007 945	Chip 1kohm 1/10W	RM73B--102J
R076,077	247 0009 082	Chip 10kohm 1/10W	RM73B--103J
R078	247 0014 912	Chip 620kohm 1/10W	RM73B--624J
R080	247 0009 901	Chip 4.7kohm 1/10W	RM73B--472J
R081-085	247 0007 945	Chip 1kohm 1/10W	RM73B--102J
R087	247 0009 082	Chip 10kohm 1/10W	RM73B--103J
R088	247 0007 945	Chip 1kohm 1/10W	RM73B--102J
R090	247 0008 928	Chip 2.2kohm 1/10W	RM73B--222J
R091,092	247 0010 903	Chip 12kohm 1/10W	RM73B--123J
R093	247 0009 927	Chip 5.6kohm 1/10W	RM73B--562J
R095	247 0011 960	Chip 56kohm 1/10W	RM73B--563J
R096	247 0018 905	Chip 0ohm 1/10W	RM73B--0R0K
R097	247 0006 904	Chip 270kohm 1/10W	RM73B--271J
R098	247 0018 905	Chip 0ohm 1/10W	RM73B--0R0K
R101	247 0009 901	Chip 4.7kohm 1/10W	RM73B--472J
R102	247 0010 961	Chip 22kohm 1/10W	RM73B--223J
R103	247 0001 909	Chip 2.2ohm 1/10W	RM73B--2R2K
△R104	244 2051 945	Metallic film 1ohm 1W	RS14B3A010JNBS(S)
R105	247 0009 998	Chip 11kohm 1/10W	RM73B--113J
R106	247 0010 961	Chip 22kohm 1/10W	RM73B--223J
R107	247 0001 909	Chip 2.2ohm 1/10W	RM73B--2R2K
△R108	244 2043 982	Metallic film 0.22ohm 1W	RS14B3AR22JNBS(S)
R109,110	247 0009 082	Chip 10kohm 1/10W	RM73B--103J
R111	247 0004 922	Chip 47ohm 1/10W	RM73B--470J
R112	247 0002 982	Chip 12ohm 1/10W	RM73B--120J
△R113	244 0011 026	Metallic film 3.3ohm 1W	RS14B3A3R3JNBS(S)
R114	245 2369 928	Metal film 10kohm 1/4W	RN14K2E103F(5)
R115	245 2369 902	Metal film 8.2kohm 1/4W	RN14K2E822F(5)
R116	247 0004 922	Chip 47ohm 1/10W	RM73B--470J
R117	247 0002 982	Chip 12ohm 1/10W	RM73B--120J
△R118	244 2051 945	Metallic film 1ohm 1W	RS14B3A010JNBS(S)
R119	247 0009 082	Chip 10kohm 1/10W	RM73B--103J
R120	245 2376 005	Metal film 5.1kohm 1/4W	RN14K2E512F(5)
R121,122	247 0010 961	Chip 22kohm 1/10W	RM73B--223J
R124	247 0009 082	Chip 10kohm 1/10W	RM73B--103J
R125	247 0007 903	Chip 680ohm 1/10W	RM73B--681J
R126	247 0014 967	Chip 1Mohm 1/10W	RM73B--105J
R127	247 0009 943	Chip 6.8kohm 1/10W	RM73B--682J
R128	247 0010 961	Chip 22kohm 1/10W	RM73B--223J
R129	247 0001 909	Chip 2.2ohm 1/10W	RM73B--2R2K
△R130	244 2051 945	Metallic film 1ohm 1W	RS14B3A010JNBS(S)
R131	247 0009 943	Chip 6.8kohm 1/10W	RM73B--682J
R132	247 0010 961	Chip 22kohm 1/10W	RM73B--223J
R133	247 0001 909	Chip 2.2ohm 1/10W	RM73B--2R2K
△R134	244 2051 945	Metallic film 1ohm 1W	RS14B3A010JNBS(S)
R135,136	247 0010 961	Chip 22kohm 1/10W	RM73B--223J
R137	245 2368 945	Metal film 4.7kohm 1/4W	RN14K2E472F(5)
△R139,140	244 2043 937	Metallic film 10ohm 1W	RS14B3A100JNBS(S)
R141,142	247 0004 922	Chip 47ohm 1/10W	RM73B--470J
R150	245 2369 902	Metal film 8.2kohm 1/4W	RN14K2E822F(5)
R151	247 0018 905	Chip 0ohm 1/10W	RM73B--0R0K
R201	247 0006 962	Chip 470ohm 1/10W	RM73B--471J
R202	247 0010 084	Chip 27kohm 1/10W	RM73B--273J
R203	247 0010 929	Chip 15kohm 1/10W	RM73B--153J
R204	247 0008 928	Chip 2.2kohm 1/10W	RM73B--222J
R205	247 0007 929	Chip 820ohm 1/10W	RM73B--821J

Ref. No.	Part No.	Part Name	Remarks
R206	247 0008 928	Chip 2.2kohm 1/10W	RM73B--222J
R207	247 0004 980	Chip 82ohm 1/10W	RM73B--820J
R208	247 0009 901	Chip 4.7kohm 1/10W	RM73B--472J
R209,210	247 0007 945	Chip 1kohm 1/10W	RM73B--102J
R221,222	247 0007 945	Chip 1kohm 1/10W	RM73B--102J
R223,224	247 0009 901	Chip 4.7kohm 1/10W	RM73B--472J
R225,226	247 0006 920	Chip 330ohm 1/10W	RM73B--331J
R227,228	247 0008 083	Chip 3.9kohm 1/10W	RM73B--392J
R229,230	247 0010 929	Chip 15kohm 1/10W	RM73B--153J
R231,232	247 0014 938	Chip 750kohm 1/10W	RM73B--754J
R233,234	247 0009 969	Chip 8.2kohm 1/10W	RM73B--822J
R235,236	247 0012 969	Chip 150kohm 1/10W	RM73B--154J
R237,238	247 0012 927	Chip 100kohm 1/10W	RM73B--104J
R239	247 0018 905	Chip 0ohm 1/10W	RM73B--0R0K
R240	247 0011 944	Chip 47kohm 1/10W	RM73B--473J
R241	247 0018 905	Chip 0ohm 1/10W	RM73B--0R0K
R242	247 0011 944	Chip 47kohm 1/10W	RM73B--473J
R301	247 0009 082	Chip 10kohm 1/10W	RM73B--103J
R302	247 0009 901	Chip 4.7kohm 1/10W	RM73B--472J
R303	247 0006 946	Chip 390ohm 1/10W	RM73B--391J
R304	247 0011 944	Chip 47kohm 1/10W	RM73B--473J
R305	247 0008 960	Chip 3.3kohm 1/10W	RM73B--332J
R306	247 0011 944	Chip 47kohm 1/10W	RM73B--473J
R307	247 0007 945	Chip 1kohm 1/10W	RM73B--102J
R308	247 0011 944	Chip 47kohm 1/10W	RM73B--473J
R309,310	247 0009 082	Chip 10kohm 1/10W	RM73B--103J
R311-328	247 0011 944	Chip 47kohm 1/10W	RM73B--473J
R329-338	247 0007 945	Chip 1kohm 1/10W	RM73B--102J
R341	247 0009 901	Chip 4.7kohm 1/10W	RM73B--472J
R342,343	247 0009 082	Chip 10kohm 1/10W	RM73B--103J
R355	247 0018 905	Chip 0ohm 1/10W	RM73B--0R0K
R357-359	247 0018 905	Chip 0ohm 1/10W	RM73B--0R0K
R360,361	247 0011 944	Chip 47kohm 1/10W	RM73B--473J
R362	247 0009 901	Chip 4.7kohm 1/10W	RM73B--472J
R363-370	247 0018 905	Chip 0ohm 1/10W	RM73B--0R0K
R371	247 0012 927	Chip 100kohm 1/10W	RM73B--104J
△R704	244 2064 903	Metallic film 0.27ohm 1W	RS14B3AR27JNBS(S)
R705	247 0011 902	Chip 33kohm 1/10W	RM73B--333J
R706	247 0008 902	Chip 1.8kohm 1/10W	RM73B--182J
R707	247 0008 973	Chip 3.6kohm 1/10W	RM73B--362J
R708	247 0009 927	Chip 5.6kohm 1/10W	RM73B--562J
R709	247 0010 961	Chip 22kohm 1/10W	RM73B--223J
R710	247 0009 082	Chip 10kohm 1/10W	RM73B--103J
△R711	244 2043 911	Metallic film 18ohm 1W	RS14B3A180JNBS(S)
R712	247 0005 947	Chip 150ohm 1/10W	RM73B--151J
R713	247 0007 903	Chip 680ohm 1/10W	RM73B--681J
R714	247 0005 921	Chip 120ohm 1/10W	RM73B--121J
R715	247 0010 903	CHIP 12kohm 1/10W	RM73B--123J
△R716	244 2055 970	Metallic film 56ohm 1W	RS14B3A560JNBS(S)
△R717	244 2055 954	Metallic film 150ohm 1W	RS14B3A151JNBS(S)
R719	247 0006 962	Chip 470ohm 1/10W	RM73B--471J
△R720	244 2064 916	Metallic film 2.2ohm 1W	RS14B3A2R2JNBS(S)
R721	247 0009 082	Chip 10kohm 1/10W	RM73B--103J
△R741	244 2043 063	Metallic film 15ohm 1W	RS14B3A150JNBS(S)
△R742	244 2050 320	Metallic film 120ohm 1W	RS14B3A121JNBS(S)
△R751,752	244 2051 974	Metallic film 1kohm 1W	RS14B3A102JNBS(S)
△R759-764	244 2051 974	Metallic film 1kohm 1W	RS14B3A102JNBS(S)

Ref. No.	Part No.	Part Name	Remarks	Ref. No.	Part No.	Part Name	Remarks
R765	247 0008 083	Chip 3.9kohm 1/10W	RM73B--392J	C106	254 3056 988	Electrolytic 0.22 μ F/50V (Bipolar)	CE04D1HR22MBP
R766	247 0008 928	Chip 2.2kohm 1/10W	RM73B--222J	C107	257 0006 901	Chip(Ceramic) 390pF/50V	CC73SL1H391J
R767.768	247 0005 905	Chip 100ohm 1/10W	RM73B--101J	C108	254 3056 988	Electrolytic 0.22 μ F/50V (Bipolar)	CE04D1HR22MBP
CAPACITORS GROUP				C109.110	254 4254 938	Electrolytic 47 μ F/16V	CE04W1C470M
C001	254 4254 912	Electrolytic 22 μ F/16V	CE04W1C220M	C111	255 1265 994	Film 0.015 μ F/50V	CQ93M1H153J(B)
C003	256 1034 076	Metalized 0.047 μ F/50V	CF93A1H473J	C112	257 0010 900	Chip(Ceramic) 0.01 μ F/50V	CK73B1H103K
C004	256 1034 979	Metalized 0.1 μ F/50V	CF93A1H104J	C113	254 3056 988	Electrolytic 0.22 μ F/50V (Bipolar)	CE04D1HR22MBP
C005	254 4254 938	Electrolytic 47 μ F/16V	CE04W1C470M	C114	257 0010 900	Chip(Ceramic) 0.01 μ F/50V	CK73B1H103K
C007	255 1264 924	Film 0.0015 μ F/50V	CQ93M1H152J(B)	C115	254 3056 988	Electrolytic 0.22 μ F/50V (Bipolar)	CE04D1HR22MBP
C008	257 0009 966	Chip(Ceramic) 0.0047 μ F/50V	CK73B1H472K	C118.119	254 3053 949	Electrolytic 100 μ F/16V (Bipolar)	CE04D1C101MBP
C009-011	254 4260 948	Electrolytic 1 μ F/50V	CE04W1H010M	C201.202	257 0004 987	Chip(Ceramic) 120pF/50V	CC73SL1H121J
C012	254 4260 964	Electrolytic 3.3 μ F/50V	CE04W1H3R3M	C203-205	257 0010 900	Chip(Ceramic) 0.01 μ F/50V	CK73B1H103K
C013	257 0009 937	Chip(Ceramic) 0.0027 μ F/50V	CK73B1H272K	C208	254 4260 948	Electrolytic 1 μ F/50V	CE04W1H010M
C014	257 0005 960	Chip(Ceramic) 270pF/50V	CC73SL1H271J	C209.210	257 0010 900	Chip(Ceramic) 0.01 μ F/50V	CK73B1H103K
C015	254 4252 927	Electrolytic 47 μ F/10V	CE04W1A470M	C211	254 4250 932	Electrolytic 220 μ F/6.3V	CE04W0J221M
C017	257 0004 961	Chip(Ceramic) 100pF/50V	CC73SL1H101J	C212	257 0014 935	Chip(Ceramic) 0.1 μ F/25V	CK73F1E104Z
C018.019	254 4252 927	Electrolytic 47 μ F/10V	CE04W1A470M	C213.214	254 4252 930	Electrolytic 100 μ F/10V	CE04W1A101M
C020-022	254 4254 909	Electrolytic 10 μ F/16V	CE04W1C100M	C215	257 0005 986	Chip(Ceramic) 330pF/50V	CC73SL1H331J
C023.024	256 1034 076	Metalized 0.1 μ F/50V	CF93A1H104J	C216	257 0005 960	Chip(Ceramic) 270pF/50V	CC73SL1H271J
C025	257 0014 935	Chip(Ceramic) 0.1 μ F/25V	CK73F1E104Z	C217.218	255 1265 978	Film 0.022 μ F/50V	CQ93M1H223J(B)
C026	254 4260 948	Electrolytic 1 μ F/50V	CE04W1H010M	C219.220	257 0009 995	Chip(Ceramic) 0.0082 μ F/50V	CK73B1H822K
C027	257 0009 924	Chip(Ceramic) 0.0022 μ F/50V	CK73B1H222K	C221.222	254 4254 912	Electrolytic 22 μ F/16V	CE04W1C220M
C028.029	257 0006 943	Chip(Ceramic) 560pF/50V	CC73SL1H561J	C223.224	257 0009 966	Chip(Ceramic) 0.0047 μ F/50V	CK73B1H472K
C030	257 0005 986	Chip(Ceramic) 330pF/50V	CC73SL1H331J	C225.226	255 1264 982	Film 0.0047 μ F/50V	CQ93M1H472J(B)
C031.032	257 0003 920	Chip(Ceramic) 27pF/50V	CC73SL1H270J	C227.228	257 0004 903	Chip(Ceramic) 56pF/50V	CC73SL1H560J
C033	254 4260 948	Electrolytic 1 μ F/50V	CE04W1H010M	C229.230	256 1034 021	Metalized 0.039 μ F/50V	CF93A1H393J
C034	254 4252 927	Electrolytic 47 μ F/10V	CE04W1A470M	C231	254 4254 909	Electrolytic 10 μ F/16V	CE04W1C100M
C035.036	254 4252 927	Electrolytic 47 μ F/10V	CE04W1A470M	C232	254 4260 935	Electrolytic 0.47 μ F/50V	CE04W1HR47M
C037.038	257 0007 900	Chip(Ceramic) 0.001 μ F/50V	CC73SL1H102J	C233	256 1034 076	Metalized 0.1 μ F/50V	CF93A1H104J
C039	255 1249 994	Film 0.015 μ F/50V	CQ93M1H153J(B)	C234	257 0014 935	Chip(Ceramic) 0.1 μ F/25V	CK73F1E104Z
C040	257 0009 924	Chip(Ceramic) 0.0022 μ F/50V	CK73B1H222K	C235.236	254 4254 909	Electrolytic 10 μ F/16V	CE04W1C100M
C041	257 0009 966	Chip(Ceramic) 0.0047 μ F/50V	CK73B1H472K	C237	254 4250 932	Electrolytic 220 μ F/6.3V	CE04W0J221M
C042	254 4254 918	Electrolytic 10 μ F/35V	CE04W1V100M	C238	254 4250 932	Electrolytic 220 μ F/6.3V	CE04W0J221M
C043.044	257 0010 900	Chip(Ceramic) 0.01 μ F/50V	CK73B1H103K	C239.240	254 3052 908	Electrolytic 22 μ F/10V (Bipolar)	CE04D1A220MBP
C045.046	257 0011 996	Chip(Ceramic) 0.1 μ F/25V	CK73B1E104K	C241	254 4250 932	Electrolytic 220 μ F/6.3V	CE04W0J221M
C047	254 4252 927	Electrolytic 47 μ F/10V	CE04W1A470M	C301	254 4252 930	Electrolytic 100 μ F/10V	CE04W1A101M
C048	254 4252 930	Electrolytic 100 μ F/10V	CE04W1A101M	C302.303	257 0014 935	Chip(Ceramic) 0.1 μ F/25V	CK73F1E104Z
C050	257 0010 900	Chip(Ceramic) 0.01 μ F/50V	CK73B1H103K	C304	254 4260 935	Electrolytic 0.47 μ F/50V	CE04W1HR47M
C051	257 0014 935	Chip(Ceramic) 0.1 μ F/25V	CK73F1E104Z	C305	257 0010 900	Chip(Ceramic) 0.01 μ F/50V	CK73B1H103K
C054.055	257 0014 935	Chip(Ceramic) 0.1 μ F/25V	CK73F1E104Z	C306-308	257 0014 935	Chip(Ceramic) 0.1 μ F/25V	CK73F1E104Z
C056	257 0003 904	Chip(Ceramic) 22pF/50V	CC73SL1H220J	C310	257 0014 935	Chip(Ceramic) 0.1 μ F/25V	CK73F1E104Z
C057	257 0010 900	Chip(Ceramic) 0.01 μ F/50V	CK73B1H103K	C701-703	257 0011 967	Chip(Ceramic) 0.033 μ F/25V	CK73B1E333K
C062	257 0010 942	Chip(Ceramic) 0.022 μ F/50V	CK73B1H223K	C704-706	254 3056 959	Electrolytic 10 μ F/50V (Bipolar)	CE04D1H100MBP
C063-068	257 0014 935	Chip(Ceramic) 0.1 μ F/25V	CK73F1E104Z	C707	257 0007 900	Chip(Ceramic) 0.001 μ F/50V	CC73SL1H102J
C080	257 0010 900	Chip(Ceramic) 0.01 μ F/50V	CK73B1H103K	C708	256 1034 076	Metalized 0.1 μ F/50V	CF93A1H104J
C090.091	257 0011 967	Chip(Ceramic) 0.033 μ F/25V	CK73B1E333K	C709	254 4252 927	Electrolytic 47 μ F/10V	CE04W1A470M
C092	256 1034 050	Metalized 0.068 μ F/50V	CF93A1H683J	C710	254 3056 014	Electrolytic 1 μ F/50V (Bipolar)	CE04D1H010MBP
C093	257 0010 900	Chip(Ceramic) 0.01 μ F/50V	CK73B1H103K	C711	254 4260 948	Electrolytic 1 μ F/50V	CE04W1H010M
C094	254 4254 912	Electrolytic 22 μ F/16V	CE04W1C220M	C712	254 4260 906	Electrolytic 0.1 μ F/50V	CE04W1H0R1M
C096	257 0001 951	Chip(Ceramic) 3pF/50V	CC73SL1H3R0C	C713	254 4260 993	Electrolytic 22 μ F/50V	CE04W1H220M
C101	257 0010 900	Chip(Ceramic) 0.01 μ F/50V	CK73B1H103K	C714	255 4213 956	Film 0.0068 μ F/50V	CQ93M1H682J(B)
C102	254 3056 988	Electrolytic 0.22 μ F/50V (Bipolar)	CE04D1HR22MBP	C715	256 1034 018	Metalized 0.033 μ F/50V	CF93A1H333J
C103	257 0010 900	Chip(Ceramic) 0.01 μ F/50V	CK73B1H103K	C716	257 0006 969	Chip(Ceramic) 680pF/50V	CC73SL1H681J
C104	254 3056 988	Electrolytic 0.22 μ F/50V (Bipolar)	CE04D1HR22MBP	C718	256 1034 076	Metalized 0.1 μ F/50V	CF93A1H104J
C105	257 0003 988	Chip(Ceramic) 47pF/50V	CC73SL1H470J	C730	254 4254 938	Electrolytic 47 μ F/16V	CE04W1C470M
				C731	257 0014 935	Chip(Ceramic) 0.1 μ F/25V	CK73F1E104Z
				C732	254 4254 938	Electrolytic 47 μ F/16V	CE04W1C470M

2U-2571 SUB UNIT

Ref. No.	Part No.	Part Name	Remarks
C733.734	254 4254 950	Electrolytic 100µF/35V	CE04W1V101M
C735	254 4256 949	Electrolytic 100µF/25V	CE04W1E101M
C736	257 0010 900	Chip(Ceramic) 0.01µF/50V	CK73B1H103K
C737	254 4260 977	Electrolytic 4.7µF/50V	CE04W1H4R7M
C738.739	257 0014 935	Chip(Ceramic) 0.1µF/25V	CK73F1E104Z
C740	254 4254 938	Electrolytic 47µF/16V	CE04W1C470M
C741.742	257 0014 935	Chip(Ceramic) 0.1µF/25V	CK73F1E104Z
C743	254 4254 938	Electrolytic 47µF/16V	CE04W1C470M
C744.745	257 0014 935	Chip(Ceramic) 0.1µF/25V	CK73F1E104Z
C746	254 4254 938	Electrolytic 47µF/16V	CE04W1C470M
C747.748	257 0014 935	Chip(Ceramic) 0.1µF/25V	CK73F1E104Z
C749	254 4254 938	Electrolytic 47µF/16V	CE04W1C470M
C753.754	257 0014 935	Chip(Ceramic) 0.1µF/25V	CK73F1E104Z
C755	254 4254 938	Electrolytic 47µF/16V	CE04W1C470M
C756	257 0014 935	Chip(Ceramic) 0.1µF/25V	CK73F1E104Z
C757-759	254 4254 938	Electrolytic 47µF/16V	CE04W1C470M

OTHERS GROUP

FL223	261 0133 909	Band Pass Filter	2.3MHz
FL228	261 0134 908	Band Pass Filter	2.8MHz
L001-007	235 0070 937	Inductor 33µH	
L201	235 0070 940	Inductor 39µH	
L202	235 0060 921	Inductor 18µH	
L301	235 0070 924	Inductor 27µH	
L701	232 0176 007	Choke Coil	94uH ELC15E008
LC001	399 0199 002	Low Pass Filter	1.7MHz
X001	399 0197 004	Crystal resonator	21.0MHz
X301	399 0195 909	Crystal resonator	8.0MHz EFOGC8004A4
CN3	205 0233 032	3P EH Connector Base	
CN7	205 0702 068	7P FFC Connector Base(L)	To Loading Mech
CN8A	205 8024 001	8P Connector Base	
CN8C	205 8026 009	8P IL-S Connector Base(L)	
CN9A	205 8024 014	9P Connector Base	
CN11	205 0275 016	11P EH Connector Base	
CN13A	205 0824 027	13P EH Connector Base	
CN13C	205 0668 063	13P FFC Connector Base	To Sub Unit
CN15A	205 0668 005	15P FFC Connector Base	
CN15C	205 0827 008	15P IL-S Connector Base(L)	
CN17A	205 0702 071	17P FFC Connector Base	To Display Unit
CN27	205 0702 084	27P FFC Connector Base(L)	To Traverse Mech
	203 2293 029	2P SMR Connector Ass'y	
	417 0486 000	Mini Radiator	For TR104. TR725

Ref. No.	Part No.	Part Name	Remarks
SEMICONDUCTORS GROUP			
IC401	263 0874 002	IC AN2661NK	
IC402	262 1810 004	IC MB88327	
IC404	262 1211 904	IC HD14053BFP-TR	
IC501	262 1599 105	IC YVZ152-F	
IC502	262 1774 001	IC LM33464G-12	
IC503	262 1683 901	IC CXA1145M	
IC601	262 1803 008	IC MN6626	
IC602	262 1764 901	IC SM5841AS	
IC603	262 1616 004	IC HG62E33R79FS	
IC604.605	262 1171 002	IC PCM61P	
IC606.607	263 0672 903	IC BA4558F	
IC608.609	262 1211 904	IC HD14053BFP-TR	
IC610	263 0672 903	IC BA4558F	
IC611	262 1211 904	IC HD14053BFP-TR	
IC612.613	263 0672 903	IC BA4558F	
IC614	262 1205 907	IC TC74HCU04AF	
IC801	262 1799 002	IC MN8811	
IC802	262 1800 001	IC MN8812	
IC803.804	262 1798 003	IC MB81C1501	
IC805	262 0707 901	IC TC4053BF	
IC901	262 1797 004	IC MN187324XGD	
IC903	499 0150 008	IC SBX1610-52	Remote Sensor
IC951	263 0690 901	IC NJM4556MB	
TR401	928 0036 701	Transistor 2SD601A	
TR402	928 0022 100	Transistor 2SC2295	
TR403	928 0036 701	Transistor 2SD601A	
TR404	272 0125 904	Transistor 2SB709A	
TR405-407	928 0036 701	Transistor 2SD601A	
TR410	272 0125 904	Transistor 2SB709A	
TR411.412	928 0036 701	Transistor 2SD601A	
TR427	928 0022 100	Transistor 2SC2295	
TR428	928 0036 701	Transistor 2SD601A	
TR429	928 0024 302	Transistor UN2211	
TR501.502	928 0036 701	Transistor 2SD601A	
TR503	272 0125 904	Transistor 2SB709A	
TR504	274 0036 701	Transistor 2SD601A	
TR601-604	274 0155 909	Transistor 2SD1306NETL	
TR605	928 0024 302	Transistor UN2211	
TR606	269 0139 907	Transistor UN2116	
TR607	928 0024 302	Transistor UN2211	
TR801-803	928 0036 701	Transistor 2SD601A	
TR804-808	272 0125 904	Transistor 2SB709A	
TR809	928 0036 701	Transistor 2SD601A	
TR810	272 0125 904	Transistor 2SB709A	
TR811-813	928 0036 701	Transistor 2SD601A	
TR814	272 0125 904	Transistor 2SB709A	
TR815.816	928 0036 701	Transistor 2SD601A	
TR818-822	928 0036 701	Transistor 2SD601A	
TR825	269 0132 904	Transistor UN2111	
TR827	272 0125 904	Transistor 2SB709A	
TR830	928 0024 302	Transistor UN2211	
TR901	928 0024 302	Transistor UN2211	
TR951.952	274 0155 909	Transistor 2SD1306NETL	
D401.402	276 0432 000	Diode 1SS270A	

Ref. No.	Part No.	Part Name	Remarks	Ref. No.	Part No.	Part Name	Remarks
D404.405	276 0432 000	Diode 1SS270A		R461	247 0013 900	Chip 220kohm 1/10W	RM73B--224J
D601	276 0432 000	Diode 1SS270A		R462	247 0008 928	Chip 2.2kohm 1/10W	RM73B--222J
D602	276 0554 014	Diode FC54M		R463	247 0007 945	Chip 1kohm 1/10W	RM73B--102J
D603	276 0432 000	Diode 1SS270A		R464	247 0005 989	Chip 220ohm 1/10W	RM73B--221J
D801.802	276 0432 000	Diode 1SS270A		R465	247 0007 945	Chip 1kohm 1/10W	RM73B--102J
D901-904	276 0432 000	Diode 1SS270A		R466	247 0009 901	Chip 4.7kohm 1/10W	RM73B--472J
LD901	393 9464 905	LED SEL-1410G	Green	R480	247 0008 928	Chip 2.2kohm 1/10W	RM73B--222J
RESISTORS GROUP (Not included Carbon Film±5%/14W)				R481	247 0006 988	Chip 560ohm 1/10W	RM73B--561J
VR602.603	211 6093 970	Adjust 100kohm	V06PB104	R482-493	247 0005 905	Chip 100ohm 1/10W	RM73B--101J
VR801	211 6093 938	Adjust 1kohm	VO6PB102	R494	247 0007 945	Chip 1kohm 1/10W	RM73B--102J
VR951	211 0764 001	Variable	VO920FA203	R495	247 0005 905	Chip 100ohm 1/10W	RM73B--101J
R401	247 0010 961	Chip 22kohm 1/10W	RM73B--223J	R501.502	247 0011 944	Chip 47kohm 1/10W	RM73B--473J
R402	247 0009 943	Chip 6.8kohm 1/10W	RM73B--682J	R503	247 0009 082	Chip 10kohm 1/10W	RM73B--103J
R403	247 0008 928	Chip 2.2kohm 1/10W	RM73B--222J	R504	247 0014 967	Chip 1Mohm 1/10W	RM73B--105J
R404	247 0006 920	Chip 330ohm 1/10W	RM73B--331J	R505	247 0006 920	Chip 330ohm 1/10W	RM73B--331J
R405	247 0008 928	Chip 2.2kohm 1/10W	RM73B--222J	R506-508	247 0006 962	Chip 470ohm 1/10W	RM73B--471J
R406	247 0006 946	Chip 390ohm 1/10W	RM73B--391J	R509-511	247 0005 905	Chip 100ohm 1/10W	RM73B--101J
R407.408	247 0006 962	Chip 470ohm 1/10W	RM73B--471J	R512.513	247 0007 945	Chip 1kohm 1/10W	RM73B--102J
R409	247 0005 947	Chip 150ohm 1/10W	RM73B--151J	R514	247 0005 947	Chip 150ohm 1/10W	RM73B--151J
R410	247 0007 929	Chip 820ohm 1/10W	RM73B--821J	R515	247 0008 902	Chip 1.8kohm 1/10W	RM73B--182J
R411	247 0008 960	Chip 3.3kohm 1/10W	RM73B--332J	R516	247 0007 945	Chip 1kohm 1/10W	RM73B--102J
R412	247 0006 962	Chip 470ohm 1/10W	RM73B--471J	R517	245 2370 920	Metal film 27kohm 1/4W	RN14K2E273F(5)
R413	247 0010 084	Chip 27kohm 1/10W	RM73B--273J	R518	247 0005 963	Chip 180ohm 1/10W	RM73B--181J
R414	247 0010 903	Chip 12kohm 1/10W	RM73B--123J	R519	247 0008 928	Chip 2.2kohm 1/10W	RM73B--222J
R415	247 0012 943	Chip 120kohm 1/10W	RM73B--124J	R520	247 0008 902	Chip 1.8kohm 1/10W	RM73B--182J
R416	247 0012 927	Chip 100kohm 1/10W	RM73B--104J	R521.522	247 0010 961	Chip 22kohm 1/10W	RM73B--223J
R417	247 0009 082	Chip 10kohm 1/10W	RM73B--103J	R523	247 0008 928	Chip 2.2kohm 1/10W	RM73B--222J
R418	247 0006 988	Chip 560ohm 1/10W	RM73B--561J	R524-528	247 0011 944	Chip 47kohm 1/10W	RM73B--473J
R419	247 0006 962	Chip 470ohm 1/10W	RM73B--471J	R529	247 0009 082	Chip 10kohm 1/10W	RM73B--103J
R420	247 0008 902	Chip 1.8kohm 1/10W	RM73B--182J	R530	247 0009 927	Chip 5.6kohm 1/10W	RM73B--562J
R421	247 0006 991	Chip 620ohm 1/10W	RM73B--621J	R531	247 0009 943	Chip 6.8kohm 1/10W	RM73B--682J
R422	247 0009 037	Chip 6.2kohm 1/10W	RM73B--622J	R532	247 0007 945	Chip 1kohm 1/10W	RM73B--102J
R423	247 0005 989	Chip 220ohm 1/10W	RM73B--221J	R533	247 0009 082	Chip 10kohm 1/10W	RM73B--103J
R424	247 0006 988	Chip 560ohm 1/10W	RM73B--561J	R534	247 0009 943	Chip 6.8kohm 1/10W	RM73B--682J
R425	247 0008 944	Chip 2.7kohm 1/10W	RM73B--272J	R535	247 0009 082	Chip 10kohm 1/10W	RM73B--103J
R426	247 0008 083	Chip 3.9kohm 1/10W	RM73B--392J	R601	247 0007 929	Chip 820ohm 1/10W	RM73B--821J
R427	247 0006 946	Chip 390ohm 1/10W	RM73B--391J	R602.603	247 0009 082	Chip 10kohm 1/10W	RM73B--103J
R428	247 0007 929	Chip 820ohm 1/10W	RM73B--821J	R604.605	247 0008 928	Chip 2.2kohm 1/10W	RM73B--222J
R430	247 0014 941	Chip 820kohm 1/10W	RM73B--824J	R606	247 0012 927	Chip 100kohm 1/10W	RM73B--104J
R431	247 0014 909	Chip 560kohm 1/10W	RM73B--564J	R607	247 0009 082	Chip 10kohm 1/10W	RM73B--103J
R439	247 0009 927	Chip 5.6kohm 1/10W	RM73B--562J	R608.609	247 0009 901	Chip 4.7kohm 1/10W	RM73B--472J
R440	247 0009 082	Chip 10kohm 1/10W	RM73B--103J	R610	247 0011 944	Chip 47kohm 1/10W	RM73B--473J
R441-443	247 0005 905	Chip 100ohm 1/10W	RM73B--101J	R611	247 0012 927	Chip 100kohm 1/10W	RM73B--104J
R445	247 0006 962	Chip 470ohm 1/10W	RM73B--471J	R612	247 0012 901	Chip 82kohm 1/10W	RM73B--823J
R446	247 0006 959	Chip 430ohm 1/10W	RM73B--431J	R613	247 0012 927	Chip 100kohm 1/10W	RM73B--104J
R447	247 0007 945	Chip 1kohm 1/10W	RM73B--102J	R614	247 0006 962	Chip 470ohm 1/10W	RM73B--471J
R451	247 0007 945	Chip 1kohm 1/10W	RM73B--102J	R615	247 0002 966	Chip 10ohm 1/10W	RM73B--100J
R452	247 0006 904	Chip 270ohm 1/10W	RM73B--271J	R616	247 0007 945	Chip 1kohm 1/10W	RM73B--102J
R454	247 0007 945	Chip 1kohm 1/10W	RM73B--102J	R620	247 0012 927	Chip 100kohm 1/10W	RM73B--104J
R455	247 0004 964	Chip 68ohm 1/10W	RM73B--680J	R623	247 0018 905	Chip 0ohm 1/10W	RM73B--0R0K
R458	247 0008 928	Chip 2.2kohm 1/10W	RM73B--222J	R625	247 0009 943	Chip 6.8kohm 1/10W	RM73B--682J
R459	247 0018 905	Chip 0ohm 1/10W	RM73B--0R0K	R626-640	247 0005 905	Chip 100ohm 1/10W	RM73B--101J
R460	247 0008 928	Chip 2.2kohm 1/10W	RM73B--222J	R641	247 0012 998	Chip 200kohm 1/10W	RM73B--204J
				R642	247 0012 927	Chip 100kohm 1/10W	RM73B--104J
				R643	247 0012 998	Chip 200kohm 1/10W	RM73B--204J
				R644	247 0003 907	Chip 15ohm 1/10W	RM73B--150J
				R645	247 0014 925	Chip 680kohm 1/10W	RM73B--684J

Ref. No.	Part No.	Part Name	Remarks
R646	247 0012 998	Chip 200kohm 1/10W	RM73B--204J
R647	247 0012 927	Chip 100kohm 1/10W	RM73B--104J
R648	247 0012 998	Chip 200kohm 1/10W	RM73B--204J
R649	247 0003 907	Chip 15ohm 1/10W	RM73B--150J
R650	247 0014 925	Chip 680kohm 1/10W	RM73B--684J
R651	247 0013 984	Chip 470kohm 1/10W	RM73B--474J
R652	247 0014 967	Chip 1Mohm 1/10W	RM73B--105J
R653	247 0012 998	Chip 200kohm 1/10W	RM73B--204J
R654	247 0013 984	Chip 470kohm 1/10W	RM73B--474J
R655	247 0014 967	Chip 1Mohm 1/10W	RM73B--105J
R656	247 0012 998	Chip 200kohm 1/10W	RM73B--204J
R657	247 0009 082	Chip 10kohm 1/10W	RM73B--103J
R658	247 0009 927	Chip 5.6kohm 1/10W	RM73B--562J
R659	247 0009 998	Chip 11kohm 1/10W	RM73B--113J
R660-663	247 0009 901	Chip 4.7kohm 1/10W	RM73B--472J
R664	247 0009 082	Chip 10kohm 1/10W	RM73B--103J
R665.666	247 0011 944	Chip 47kohm 1/10W	RM73B--473J
R667	247 0007 945	Chip 1kohm 1/10W	RM73B--102J
R668.669	247 0006 920	Chip 330ohm 1/10W	RM73B--331J
R671	247 0009 082	Chip 10kohm 1/10W	RM73B--103J
R672	247 0009 927	Chip 5.6kohm 1/10W	RM73B--562J
R673	247 0009 998	Chip 11kohm 1/10W	RM73B--113J
R676.677	247 0009 901	Chip 4.7kohm 1/10W	RM73B--472J
R679-682	247 0011 944	Chip 47kohm 1/10W	RM73B--473J
R683.684	247 0005 976	Chip 200ohm 1/10W	RM73B--201J
R685.686	247 0009 901	Chip 4.7kohm 1/10W	RM73B--472J
R687	247 0004 922	Chip 47ohm 1/10W	RM73B--470J
R688	247 0007 929	Chip 820ohm 1/10W	RM73B--821J
R689	247 0018 905	Chip 0ohm 1/10W	RM73B--0R0K
R691.692	247 0011 944	Chip 47kohm 1/10W	RM73B--473J
R693.694	247 0005 976	Chip 200ohm 1/10W	RM73B--201J
R695.696	247 0009 901	Chip 4.7kohm 1/10W	RM73B--472J
R697	247 0006 962	Chip 470ohm 1/10W	RM73B--471J
R801	247 0006 988	Chip 560ohm 1/10W	RM73B--561J
R802	247 0008 928	Chip 2.2kohm 1/10W	RM73B--222J
R803	247 0009 082	Chip 10kohm 1/10W	RM73B--103J
R804	247 0006 991	Chip 620ohm 1/10W	RM73B--621J
R805	247 0008 928	Chip 2.2kohm 1/10W	RM73B--222J
R806	247 0009 927	Chip 5.6kohm 1/10W	RM73B--562J
R807	247 0007 945	Chip 1kohm 1/10W	RM73B--102J
R808	247 0011 944	Chip 47kohm 1/10W	RM73B--473J
R809	247 0010 929	Chip 15kohm 1/10W	RM73B--153J
R810	247 0005 989	Chip 220ohm 1/10W	RM73B--221J
R812.813	247 0006 920	Chip 330ohm 1/10W	RM73B--331J
R814	247 0009 901	Chip 4.7kohm 1/10W	RM73B--472J
R815	247 0004 922	Chip 47ohm 1/10W	RM73B--470J
R816	247 0005 905	Chip 100ohm 1/10W	RM73B--101J
R817	247 0014 967	Chip 1Mohm 1/10W	RM73B--105J
R818	247 0009 082	Chip 10kohm 1/10W	RM73B--103J
R819	247 0007 945	Chip 1kohm 1/10W	RM73B--102J
R820.821	247 0012 927	Chip 100kohm 1/10W	RM73B--104J
R822	247 0006 920	Chip 330ohm 1/10W	RM73B--331J
R823	247 0009 901	Chip 4.7kohm 1/10W	RM73B--472J
R824	247 0008 928	Chip 2.2kohm 1/10W	RM73B--222J
R825.826	247 0007 945	Chip 1kohm 1/10W	RM73B--102J
R827	247 0007 987	Chip 1.5kohm 1/10W	RM73B--152J
R828	247 0005 905	Chip 100ohm 1/10W	RM73B--101J

Ref. No.	Part No.	Part Name	Remarks
R829.830	247 0005 976	Chip 200ohm 1/10W	RM73B--201J
R831	247 0007 945	Chip 1kohm 1/10W	RM73B--102J
R832	247 0008 931	Chip 2.4kohm 1/10W	RM73B--242J
R833	247 0008 944	Chip 2.7kohm 1/10W	RM73B--272J
R834.835	247 0008 960	Chip 3.3kohm 1/10W	RM73B--332J
R836	247 0005 976	Chip 200ohm 1/10W	RM73B--201J
R837	247 0005 905	Chip 100ohm 1/10W	RM73B--101J
R838	247 0008 931	Chip 2.4kohm 1/10W	RM73B--242J
R839	247 0009 082	Chip 10kohm 1/10W	RM73B--103J
R840	247 0007 945	Chip 1kohm 1/10W	RM73B--102J
R841	247 0007 961	Chip 1.2kohm 1/10W	RM73B--122J
R842	247 0005 905	Chip 100ohm 1/10W	RM73B--101J
R843	247 0007 945	Chip 1kohm 1/10W	RM73B--102J
R844	247 0006 962	Chip 470ohm 1/10W	RM73B--471J
R845	247 0007 932	Chip 910ohm 1/10W	RM73B--911J
R846-849	247 0007 945	Chip 1kohm 1/10W	RM73B--102J
R850	247 0010 961	Chip 22kohm 1/10W	RM73B--223J
R851	247 0007 987	Chip 1.5kohm 1/10W	RM73B--152J
R852.853	247 0006 920	Chip 330ohm 1/10W	RM73B--331J
R855.856	247 0004 977	Chip 75ohm 1/10W	RM73B--750J
R853	247 0006 988	Chip 560ohm 1/10W	RM73B--561J
R859	247 0008 928	Chip 2.2kohm 1/10W	RM73B--222J
R860	247 0008 960	Chip 3.3kohm 1/10W	RM73B--332J
R861	247 0009 901	Chip 4.7kohm 1/10W	RM73B--472J
R862	247 0006 920	Chip 330ohm 1/10W	RM73B--331J
R863	247 0009 082	Chip 10kohm 1/10W	RM73B--103J
R864	247 0004 977	Chip 75ohm 1/10W	RM73B--750J
R865	247 0006 920	Chip 330ohm 1/10W	RM73B--331J
R868	247 0004 977	Chip 75ohm 1/10W	RM73B--750J
R869.870	247 0009 985	Chip 10kohm 1/10W	RM73B--103J
R871	247 0005 905	Chip 100ohm 1/10W	RM73B--101J
R872	247 0008 928	Chip 2.2kohm 1/10W	RM73B--222J
R873	247 0011 944	Chip 47kohm 1/10W	RM73B--473J
R874	247 0007 903	Chip 680ohm 1/10W	RM73B--681J
R875	247 0007 929	Chip 820ohm 1/10W	RM73B--821J
R876	247 0007 945	Chip 1kohm 1/10W	RM73B--102J
R877	247 0006 962	Chip 470ohm 1/10W	RM73B--471J
R878	247 0007 903	Chip 680ohm 1/10W	RM73B--681J
R879-882	247 0006 904	Chip 270ohm 1/10W	RM73B--271J
R883	247 0009 082	Chip 10kohm 1/10W	RM73B--103J
R885	247 0009 901	Chip 4.7kohm 1/10W	RM73B--472J
R886	245 2226 003	Metal film 62kohm 1/4W	RN14K2E623G(5)
R887	245 2376 021	Metal film 7.5kohm 1/4W	RN14K2E752G(5)
R888	247 0009 082	Chip 10kohm 1/10W	RM73B--103J
R889	245 2376 092	Metal film 220kohm 1/4W	RN14K2E224G(5)
R890-893	247 0018 905	Chip 0ohm 1/10W	RM73B--0R0K
R901.902	247 0009 082	Chip 10kohm 1/10W	RM73B--103J
R903-905	247 0007 945	Chip 1kohm 1/10W	RM73B--102J
R906	247 0009 082	Chip 10kohm 1/10W	RM73B--103J
R907-914	247 0011 944	Chip 47kohm 1/10W	RM73B--473J
R917	247 0006 920	Chip 330ohm 1/10W	RM73B--331J
R919	247 0009 082	Chip 10kohm 1/10W	RM73B--103J
R921-926	247 0009 082	Chip 10kohm 1/10W	RM73B--103J
R927	247 0009 901	Chip 4.7kohm 1/10W	RM73B--472J
R928	247 0007 945	Chip 1kohm 1/10W	RM73B--102J
R929	247 0018 905	Chip 0ohm 1/10W	RM73B--0R0K
R931	247 0009 901	Chip 4.7kohm 1/10W	RM73B--472J

Ref No.	Part No.	Park Name	Remarks	Ref No.	Part No.	Park Name	Remarks
R951.952	247 0012 927	Chip 100kohm 1/10W	RM73B--104J	C513	257 0004 987	Chip(Ceramic) 120pF/50V	CC73SL1H121J
R953.954	247 0010 903	Chip 12kohm 1/10W	RM73B--123J	C514	254 4254 909	Electrolytic 10μF/16V	CE04W1C100M
R955.956	247 0009 969	Chip 8.2kohm 1/10W	RM73B--822J	C516	257 0004 903	Chip(Ceramic) 56pF/50V	CC73SL1H560J
R957.958	247 0004 948	Chip 56ohm 1/10W	RM73B--560J	C517	257 0004 987	Chip(Ceramic) 120pF/50V	CC73SL1H121J
R959--962	247 0009 901	Chip 4.7kohm 1/10W	RM73B--472J	C518	254 4260 951	Electrolytic 2.2μF/50V	CE04W1H2R2M
R963--988	247 0012 927	Chip 100kohm 1/10W	RM73B--104J	C519	255 1265 936	Film 0.01μF/50V	CQ93M1H103J(B)
CAPACITORS GROUP				C520	257 0014 935	Chip(Ceramic) 0.1μF/25V	CK73F1E104Z
C401	257 0014 935	Chip(Ceramic) 0.1μF/25V	CK73F1E104Z	C521	255 1265 936	Film 0.01μF/50V	CQ93M1H103J(B)
C402.403	257 0004 987	Chip(Ceramic) 120pF/50V	CC73SL1H121J	C522	255 1265 923	Film 0.0082μF/50V	CQ93M1H822J(B)
C404	257 0005 986	Chip(Ceramic) 330pF/50V	CC73SL1H331J	C523	255 1265 936	Film 0.01μF/50V	CQ93M1H103J(B)
C405	257 0006 927	Chip(Ceramic) 470pF/50V	CC73SL1H471J	C527	257 0010 900	Chip(Ceramic) 0.01μF/50V	CK73B1H103K
C406	257 0003 920	Chip(Ceramic) 27pF/50V	CC73SL1H270J	C601	254 4305 065	Electrolytic 1μF/50V	CE04W1H010M(SRE)
C407	257 0004 945	Chip(Ceramic) 82pF/50V	CC73SL1H820J	C602	254 3061 902	Electrolytic 1μF/50V (Bipolar)	CE04D1H010MBP
C408	257 0003 920	Chip(Ceramic) 27pF/50V	CC73SL1H270J	C603	256 1034 076	Metalized 0.1μF/50V	CF93A1H104J
C409	257 0001 951	Chip(Ceramic) 3pF/50V	CC73SL1H3R0C	C604	256 1035 017	Metalized 0.22μF/50V	CF93A1H224J
C410.411	257 0012 966	Chip(Ceramic) 0.01μF/50V	CK73F1H103Z	C605	257 0014 935	Chip(Ceramic) 0.1μF/25V	CK73F1E104Z
C412	254 4252 927	Electrolytic 47μF/10V	CE04W1A470M	C606	255 1264 908	Film 0.001μF/50V	CQ93M1H102J(B)
C413		Chip(Ceramic) 0.01μF/50V	CK73F1H103Z	C607	257 0014 935	Chip(Ceramic) 0.1μF/25V	CK73F1E104Z
C414	257 0010 900	Chip(Ceramic) 0.01μF/50V	CK73B1H103K	C608	254 4254 925	Electrolytic 33μF/16V	CE04W1C330M
C415	257 0003 904	Chip(Ceramic) 22pF/50V	CC73SL1H220J	C609	255 1265 978	Film 0.022μF/50V	CQ93M1H223J(B)
C416	257 0004 932	Chip(Ceramic) 75pF/50V	CC73SL1H750J	C610	256 1035 059	Metalized 0.47μF/50V	CF93A1H474J
C417	257 0004 958	Chip(Ceramic) 91pF/50V	CC73SL1H910J	C611	254 4252 930	Electrolytic 100μF/10V	CE04W1A101M
C418	257 0004 929	Chip(Ceramic) 68pF/50V	CC73SL1H680J	C612	257 0014 935	Chip(Ceramic) 0.1μF/25V	CK73F1E104Z
C419	254 4250 932	Electrolytic 220μF/6.3V	CE04W0J221M	C613	257 0012 966	Chip(Ceramic) 0.01μF/50V	CK73F1H103Z
C420	257 0004 945	Chip(Ceramic) 82pF/50V	CC73SL1H820J	C620	257 0006 901	Chip(Ceramic) 390pF/50V	CC73SL1H391J
C421	257 0003 975	Chip(Ceramic) 43pF/50V	CC73SL1H430J	C621	257 0002 905	Chip(Ceramic) 8pF/50V	CC73SL1H8R0D
C422	257 0012 966	Chip(Ceramic) 0.01μF/50V	CK73F1H103Z	C624	257 0014 935	Chip(Ceramic) 0.1μF/25V	CK73F1E104Z
C423	254 4252 930	Electrolytic 100μF/10V	CE04W1A101M	C625	254 4254 909	Electrolytic 10μF/16V	CE04W1C100M
C424	257 0003 920	Chip(Ceramic) 27pF/50V	CC73SL1H270J	C626-628	257 0014 935	Chip(Ceramic) 0.1μF/25V	CK73F1E104Z
C425	257 0004 929	Chip(Ceramic) 68pF/50V	CC73SL1H680J	C629.630	254 4368 934	Electrolytic 100μF/25V	CE04W1H101M(ASF)
C426	254 4260 935	Electrolytic 0.47μF/50V	CE04W1HR47M	C631-634	254 4356 001	Electrolytic 10μF/50V	CE04W1H100M(ARS)
C427-429	257 0012 966	Chip(Ceramic) 0.01μF/50V	CK73F1H103Z	C635	255 4232 005	Film 820pF/100V	CQ93P2A821J(NH)
C430	254 4252 930	Electrolytic 100μF/10V	CE04W1A101M	C636	255 4232 018	Film 180pF/100V	CQ93P2A181J(NH)
C431	254 4250 932	Electrolytic 220μF/6.3V	CE04W0J221M	C637	255 4232 034	Film 0.001μF/100V	CQ93P2A102J(NH)
C432	257 0012 966	Chip(Ceramic) 0.01μF/50V	CK73F1H103Z	C638	255 4232 076	Film 200pF/100V	CQ93P2A201J(NH)
C433	257 0004 945	Chip(Ceramic) 82pF/50V	CC73SL1H820J	C640	255 4232 005	Film 820pF/100V	CQ93P2A821J(NH)
C436	257 0007 900	Chip(Ceramic) 0.001μF/50V	CC73SL1H102J	C641	255 4232 018	Film 180pF/100V	CQ93P2A181J(NH)
C440	254 4305 065	Electrolytic 1μF/50V	CE04W1H010M(SRE)	C642	255 4232 034	Film 0.001μF/100V	CQ93P2A102J(NH)
C441.442	257 0003 946	Chip(Ceramic) 33pF/50V	CC73SL1H330J	C643	255 4232 076	Film 200pF/100V	CQ93P2A201J(NH)
C443	254 4252 930	Electrolytic 100μF/10V	CE04W1A101M	C650	254 4254 909	Electrolytic 10μF/16V	CE04W1C100M
C445	257 0005 986	Chip(Ceramic) 330pF/50V	CC73SL1H331J	C653-656	257 0014 935	Chip(Ceramic) 0.1μF/25V	CK73F1E104Z
C446	254 4254 909	Electrolytic 10μF/16V	CE04W1C100M	C657	257 0003 904	Chip(Ceramic) 22pF/50V	CC73SL1H220J
C447	257 0005 944	Chip(Ceramic) 220pF/50V	CC73SL1H221J	C660	254 4254 954	Electrolytic 220μF/16V	CE04W1C221M
C448	257 0014 935	Chip(Ceramic) 0.1μF/25V	CK73F1E104Z	C658.659	254 4356 739	Electrolytic 47μF/50V	CE04W1H470M(ARS)
C462	257 0012 966	Chip(Ceramic) 0.01μF/25V	CK73F1E103Z	C661	257 0003 904	Chip(Ceramic) 22pF/50V	CC73SL1H220J
C496	257 0004 961	Chip(Ceramic) 100pF/50V	CC73SL1H101J	C665.666	254 4356 739	Electrolytic 47μF/50V	CE04W1H470M(ARS)
C501	254 4252 927	Electrolytic 47μF/10V	CE04W1A470M	C667-670	254 4356 014	Electrolytic 100μF/50V	CE04W1H101MC(ARS)
C502-504	257 0014 935	Chip(Ceramic) 0.1μF/25V	CK73F1E104Z	C671-679	257 0014 935	Chip(Ceramic) 0.1μF/25V	CK73F1E104Z
C505	254 4252 969	Electrolytic 470μF/10V	CE04W1A471M	C681-684	257 0014 935	Chip(Ceramic) 0.1μF/25V	CK73F1E104Z
C506	257 0014 935	Chip(Ceramic) 0.1μF/25V	CK73F1E104Z	C685	257 0005 986	Chip(Ceramic) 330pF/50V	CC73SL1H331J
C507	257 0004 961	Chip(Ceramic) 100pF/50V	CC73SL1H101J	C686-689	257 0014 935	Chip(Ceramic) 0.1μF/25V	CK73F1E104Z
C508	257 0006 927	Chip(Ceramic) 470pF/50V	CC73SL1H471J	C690	254 4452 701	Electrolytic 470μF/16V	CE04W1C471MC(ASF)
C509	257 0006 969	Chip(Ceramic) 680pF/50V	CC73SL1H681J	C691.692	256 1045 007	Metalized 1μF/63V	CF93B1J105K(SA)
C510	257 0014 935	Chip(Ceramic) 0.1μF/25V	CK73F1E104Z	C693.694	256 1045 010	Metalized 0.47μF/63V	CF93B1J474K(SA)
C511.512	254 4254 909	Electrolytic 10μF/16V	CE04W1C100M	C695	257 0014 935	Chip(Ceramic) 0.1μF/25V	CK73F1E104Z
				C801	257 0003 946	Chip(Ceramic) 33pF/50V	CC73SL1H330J
				C802	257 0004 929	Chip(Ceramic) 68pF/50V	CC73SL1H680J

Ref No.	Part No.	Park Name	Remarks
C803	257 0003 946	Chip(Ceramic) 33pF/50V	CC73SL1H330J
C804	257 0001 951	Chip(Ceramic) 3pF/50V	CC73SL1H3R0C
C805	254 4252 927	Electrolytic 47μF/10V	CE04W1A470M
C806	254 4254 909	Electrolytic 10μF/16V	CE04W1C100M
C807	254 4252 927	Electrolytic 47μF/10V	CE04W1A470M
C808	257 0012 966	Chip(Ceramic) 0.01μF/50V	CK73F1H103Z
C809-811	254 4252 930	Electrolytic 100μF/10V	CE04W1A101M
C812	257 0004 987	Chip(Ceramic) 120pF/50V	CC73SL1H121J
C813-817	257 0014 935	Chip(Ceramic) 0.1μF/25V	CK73F1E104Z
C818,819	257 0003 904	Chip(Ceramic) 22pF/50V	CC73SL1H220J
C820	257 0007 900	Chip(Ceramic) 0.001μF/50V	CC73SL1H102J
C821	257 0014 935	Chip(Ceramic) 0.1μF/25V	CK73F1E104Z
C822	257 0010 900	Chip(Ceramic) 0.01μF/50V	CK73B1H103K
C823	257 0009 953	Chip(Ceramic) 0.0039μF/50V	CK73B1H392K
C824	255 1265 907	Film 0.0068μF/50V	CQ93M1H682J(B)
C825	254 4305 065	Electrolytic 1μF/50V	CE04W1H010M(SRE)
C826	257 0002 921	Chip(Ceramic) 10pF/50V	CC73SL1H100D
C827	257 0012 966	Chip(Ceramic) 0.01μF/50V	CK73F1H103Z
C828,829	257 0014 935	Chip(Ceramic) 0.1μF/25V	CK73F1E104Z
C830	257 0014 935	Chip(Ceramic) 0.1μF/25V	CK73F1E104Z
C831	254 4252 930	Electrolytic 100μF/10V	CE04W1A101M
C832	257 0014 935	Chip(Ceramic) 0.1μF/25V	CK73F1E104Z
C833	254 4252 930	Electrolytic 100μF/10V	CE04W1A101M
C834	257 0014 935	Chip(Ceramic) 0.1μF/25V	CK73F1E104Z
C835	254 4252 930	Electrolytic 100μF/10V	CE04W1A101M
C836-838	257 0014 935	Chip(Ceramic) 0.1μF/25V	CK73F1E104Z
C839	254 4305 065	Electrolytic 1μF/50V	CE04W1H010M(SRE)
C840,841	257 0014 935	Chip(Ceramic) 0.1μF/25V	CK73F1E104Z
C842	254 4252 930	Electrolytic 100μF/10V	CE04W1A101M
C843	257 0003 962	Chip(Ceramic) 39pF/50V	CC73SL1H390J
C844	257 0005 902	Chip(Ceramic) 150pF/50V	CC73SL1H151J
C845	257 0005 928	Chip(Ceramic) 180pF/50V	CC73SL1H181J
C846	257 0003 904	Chip(Ceramic) 22pF/50V	CC73SL1H220J
C847	254 4252 930	Electrolytic 100μF/10V	CE04W1A101M
C848	257 0003 946	Chip(Ceramic) 33pF/50V	CC73SL1H330J
C849	254 4252 901	Electrolytic 22μF/10V	CE04D1A220M
C850	254 4252 930	Electrolytic 100μF/10V	CE04W1A101M
C851	257 0012 966	Chip(Ceramic) 0.01μF/50V	CK73F1H103Z
C852	254 4254 909	Electrolytic 10μF/16V	CE04W1C100M
C853	257 0012 966	Chip(Ceramic) 0.01μF/50V	CK73F1H103Z
C854,855	254 4252 930	Electrolytic 100μF/10V	CE04W1A101M
C856	257 0012 966	Chip(Ceramic) 0.01μF/50V	CK73F1H103Z
C857	257 0004 961	Chip(Ceramic) 100pF/50V	CC73SL1H101J
C858	257 0005 986	Chip(Ceramic) 330pF/50V	CC73SL1H331J
C859	257 0004 961	Chip(Ceramic) 100pF/50V	CC73SL1H101J
C860	255 1265 936	Film 0.01μF/50V	CQ93M1H103J(B)
C861	257 0004 945	Chip(Ceramic) 82pF/50V	CC73SL1H820J
C862	257 0012 966	Chip(Ceramic) 0.01μF/50V	CK73F1H103Z
C863	257 0006 969	Chip(Ceramic) 680pF/50V	CC73SL1H681J
C864	256 1035 017	Metalized 0.22μF/50V	CF93A1H224J
C865	255 1265 994	Film 0.033μF/50V	CQ93M1H333J(B)
C867-870	257 0005 944	Chip(Ceramic) 220pF/50V	CC73SL1H221J
C878	257 0012 966	Chip(Ceramic) 0.01μF/50V	CK73F1H103Z
C883	255 4085 074	Film 0.0082μF/50V	CQ93P1H822G
C884	257 0004 961	Chip(Ceramic) 100pF/50V	CC73SL1H101J
C890	256 1034 076	Metalized 0.1μF/50V	CF93A1H104J
C894	257 0014 935	Chip(Ceramic) 0.1μF/25V	CK73F1E104Z

Ref No.	Part No.	Park Name	Remarks
C896	254 4250 042	Electrolytic 330μF/6.3V	CE04W0J331M
C897	254 4250 932	Electrolytic 220μF/6.3V	CE04W0J221M
C898	254 4254 938	Electrolytic 47μF/16V	CE04W1C470M
C901	254 4260 980	Electrolytic 10μF/50V	CE04W1H100M
C904	257 0012 966	Chip(Ceramic) 0.01μF/50V	CK73F1H103Z
C905	254 4254 938	Electrolytic 47μF/16V	CE04W1C470M
C907-909	257 0014 935	Chip(Ceramic) 0.1μF/25V	CK73F1E104Z
C951,952	254 4252 941	Electrolytic 100μF/16V	CE04W1C101M
C953,954	257 0004 903	Chip(Ceramic) 56pF/50V	CC73SL1H560J
C955,956	257 0012 966	Chip(Ceramic) 0.01μF/50V	CK73F1H103Z
C957	257 0014 935	Chip(Ceramic) 0.1μF/25V	CK73F1E104Z

OTHERS

Ref No.	Part No.	Park Name	Remarks
L401	235 0060 921	Inductor 18μH	
L402,403	235 0060 950	Inductor 10μH	
L404,405	235 0074 962	Inductor 6.8μH	
L406,407	235 0070 940	Inductor 39μH	
L408	235 0070 911	inductor 22μH	
L409,410	235 0070 937	Inductor 33μH	
L411	235 0060 950	Inductor 10μH	
L412	235 0060 963	Inductor 15μH	
L501	235 0070 911	Inductor 22μH	
L601	235 0060 950	Inductor 10μH	
L602	235 0074 904	Inductor 5.6μH	
L603	235 0060 950	Inductor 10μH	
L801	235 0070 940	Inductor 39μH	
L802,803	235 0070 924	Inductor 27μH	
L804,805	235 0060 950	inductor 10μH	
L806	235 0060 905	Inductor 2.2μH	
L807	235 0060 950	Inductor 10μH	
L808	235 0074 959	Inductor 3.9μH	
L809	235 0074 975	Inductor 8.2μH	
L810-814	235 0060 950	Inductor 10μH	
L815	235 0070 940	Inductor 39μH	
SW901-905	212 4388 907	Tact Switch	
SW907-911	212 4388 907	Tact Switch	
X901	399 0196 908	Ceramic Resonator	4.19MHz
DL501	231 5902 008	Delay Line	
T501	231 5901 009	Filter Coil	
X601	399 0096 008	Crystal	16MHz
X801	399 0098 003	Crystal	21.8MHz
FL801,802	261 0137 002	Band Pass Filter	14.3MHz
FL901	393 8003 008	FL Tube	
JG901	219 0013 002	Jog Shuttle Switch	
JK003	204 8265 009	4P RCA Pin Jack	
YC001	204 8426 013	S Video Out Terminal	S Video Out
JK001	204 8329 000	2P Pin Jack	
JK901	204 8322 007	Headphone Jack	
JK004	269 0098 006	Optical Out Terminal	Optical Out
CN6B	205 0343 061	6P Connector Base(KR-PH)	
CN6A	205 0343 061	6P Connector Base(KR-PH)	
CN8B	205 0823 002	8P Connector Plug	
CN9B	205 0823 015	9P Connector Plug	
CN13B	205 0823 028	13P Connector Plug	
CN13D	205 0668 063	13P FFC Connector Base	To Main Unit
CN15B	205 0668 005	15P FFC Connector Base	

2U-2759B TRANS UNIT

Ref No.	Part No.	Part Name	Remarks
CN17B	205 0668 076	17P FFC Connector Base	To Main Unit
	203 6414 008	4P SAN Shield Cord	
	203 0475 072	1P SIN Contact Ass'y	L=60 Black
	203 0503 025	1P SIN Connector Ass'y	L=80 Brown
	203 0319 044	1P SIN Connector Ass'y	L=170 Yellow
	203 0526 002	1P SIN Contact Ass'y	L=100
	203 0526 028	1P SIN Contact Ass'y	L=290
	203 2292 033	2P SAN Connector Ass'y	
	203 8367 001	5P SAN Connector Cord	
	443 8568 107	LED Holder	
	205 0452 017	Style Pin	

Ref. No.	Part No.	Part Name	Remarks
SEMICONDUCTORS GROUP			
IC707	263 0809 006	IC NJM7805FA(S)	
D720	276 0405 008	Diode S1WB(A)	
D721,722	276 0386 017	Diode S2VB20F	
RESISTORS (Not included Carbon Film $\pm 5\%$ 1/4W)			
R750	244 2064 932	Metallic film 3.9ohm 1W (Bipolar)	RS14B3A392JNBS
CAPACITORS			
C720-722	253 1053 003	Ceramic 0.01 μ F/500V	CK45E2H103P
C723,724	254 4319 792	Electrolytic 4700 μ F/25V	CE04W1E472MC(ASF)
C725	254 4255 720	Electrolytic 6800 μ F/16V	CE04W1C682MC
C726	254 4255 717	Electrolytic 4700 μ F/16V	CE04W1C472MC
C727	254 4255 704	Electrolytic 3300 μ F/16V	CE04W1C332MC
C728	254 4261 769	Electrolytic 1000 μ F/50V	CE04W1H102MC
Δ C760	253 8014 702	Ceramic 0.01 μ F/400V AC	CK45F2GAC103MC
C761	254 4260 980	Electrolytic 10 μ F/50V	CE04W1H100M
C762	253 9036 006	BC Ceramic 0.1 μ F/25V	CK45F=1E104Z
C763	254 4260 980	Electrolytic 10 μ F/50V	CE04W1H100M
C764	253 9036 006	BC Ceramic 0.1 μ F/25V	CK45F=1E104Z
OTHERS			
Δ F701-703	206 1039 050	Fuse 1.6A	
Δ F704,705	206 1039 063	Fuse 2.0A	
CN2	205 0581 001	2P VH Connector Base	
CN11	205 0775 016	11P EH Connector Base	
Δ	233 6124 001	Power Trans	
Δ	206 2100 001	AC Cord with Connector	
	202 0040 909	Fuse Clip	

2U-2572 SWITCH UNIT

Ref. No.	Part No.	Part Name	Remarks
	212 1114 006	SWITCH	
	203 4935 000	3P SAN Connector Cord	
	205 0702 068	7P FFC Connector Base	

PRINTED WIRING BOARD

1 2 3 4 5 6 7 8

2U-2570 MAIN P.W.B.

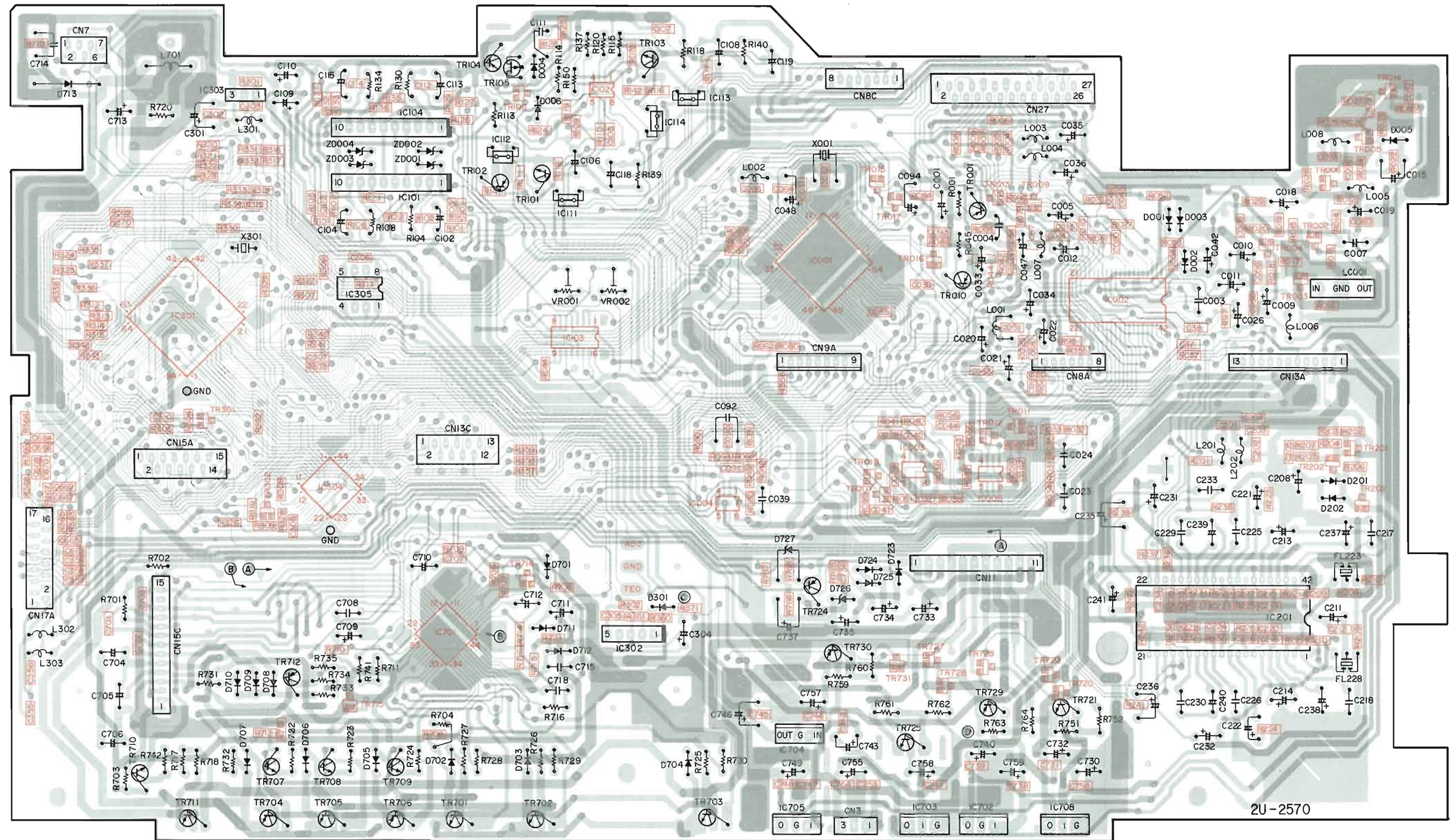

A
B
C
D
E

1

2

3

4

5

6

7

8

2U-2571 SUB P.W.B.

A

B

C

D

E

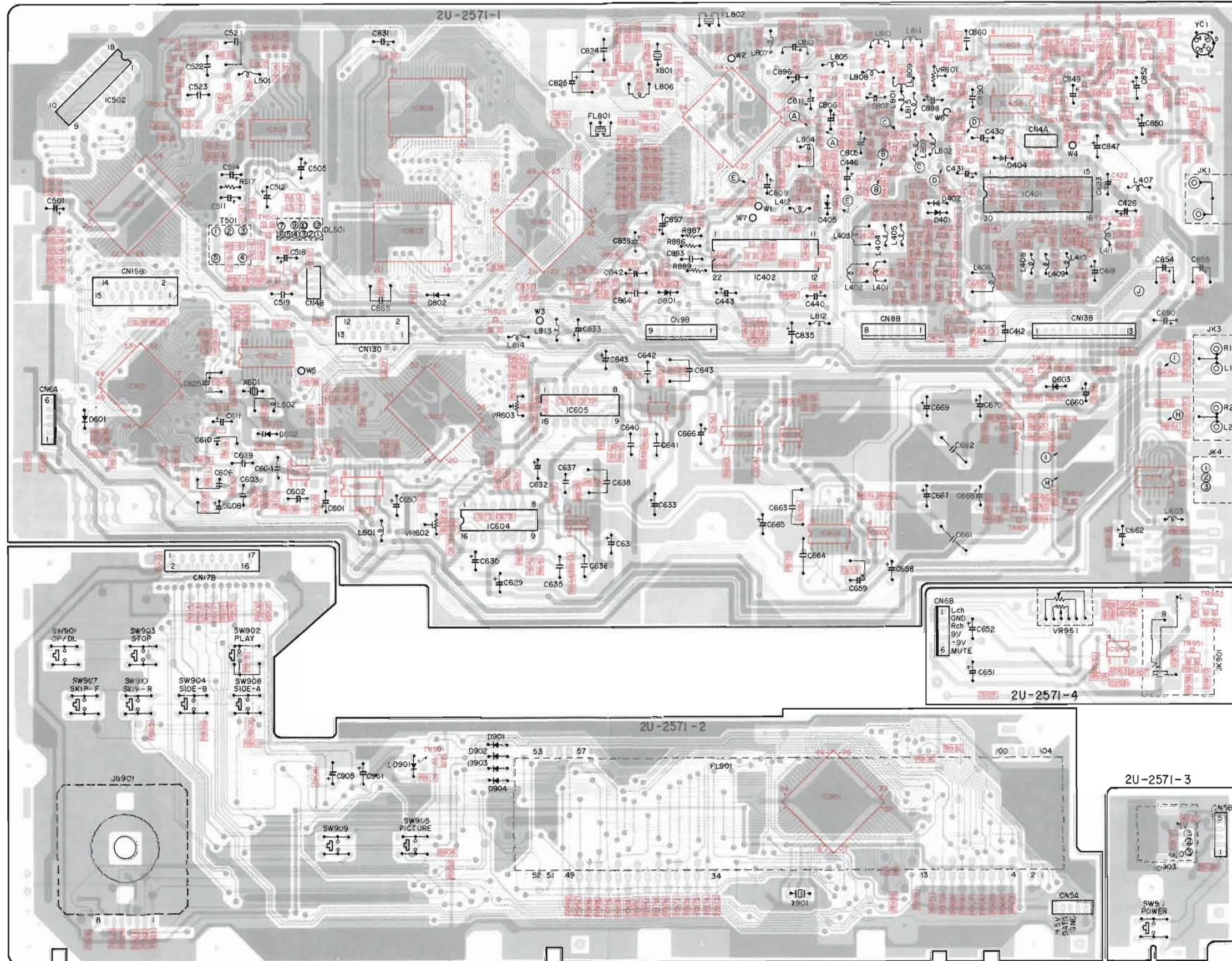

1

2

3

4

5

6

7

8

2U-2759 TRANSFORMER P.W.B.

2U-2572 SWITCH P.W.B.

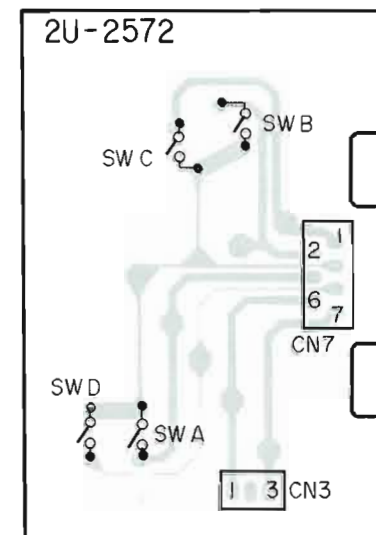
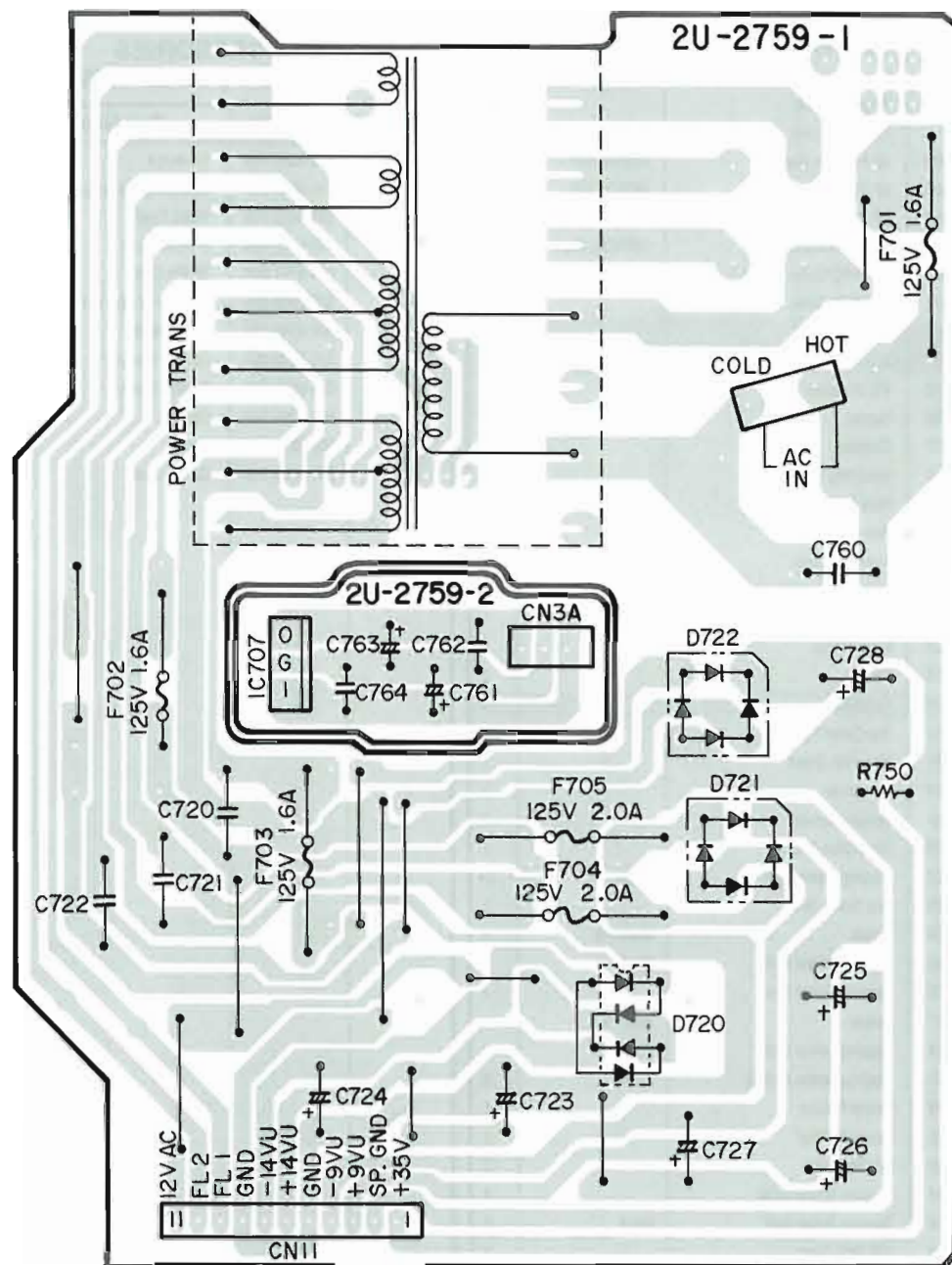

A

B

C

D

E

EXPLODED VIEW OF PARTS LIST

Ref. No.	Part No.	Part Name	Remarks	Q'ty
●	2U-2570	Main Unit Ass'y		1
●	2U-2571	Sub Unit Ass'y		1
	—	Sub Unit		
	—	Display Unit		
	—	Power Sw,Remocon Unit		
	—	Head Phone Unit		
●	2U- 2759	Trans Unit Ass'y		1
	—	Trans Unit		
	—	Regulator Unit		
17	—	Tray Drive Unit	See Page 75	1
18	204 8265 009	4P RCA Pin Jack	AUDIO OUT	1
19	204 8329 000	2P Pin Jack	VIDEO OUT	1
20	204 8426 013	1P S-Terminal	S-VIDEO OUT	1
21	269 0098 006	Optical Terminal	OPTICAL OUT	1
22	205 0702 084	27P FFC Conn. Base(L)		1
23	205 0702 071	17P FFC Conn. Base(L)		1
△	24 233 6124 001	Power Trans		1
△	25 206 2100 001	AC Cord with Connector		1
●	26 415 9016 022	P.C.B. Holder		5
●	27 409 0052 035	Holder		1
●	28 412 1236 507	Chassis		1
29	461 0598 050	Insulating Rubber		1
30	104 0194 108	Foot Ass'y		4
●	31 1051087 039	Rear Panel		1
32	337 0023 002	Traverse Mech	See Page 76	1
●	33 461 0598 047	Insulating Rubber		1
●	34 412 3716 002	Stopper Bracket		1
●	35 412 3385 307	Front Bridge		1
●	36 122 0172 018	Spacer		2
△	37 445 0056 008	Cord Bush		1
●	38 461 0813 010	Top Cover Spacer		4
40	513 1581 011	Serial No. Sheet		1
●	41 102 0540 219	Top Cover		1
42	105 1114 009	Bottom Cover		1
43	461 0850 002	Absorption Sheet		1
46	473 7002 021	Tapping Screw 3x8	Black	24
47	473 8007 025	Cup Screw 3x8		1
48	473 8049 009	Screw	Mech Fix	4
49	473 7007 000	Tapping Screw 4x8	Black	1
50	473 7002 005	Tapping Screw 3x6		2
51	477 0064 107	Screw	Jack Fix	4
52	473 7015 018	Tapping Screw 3x8	Black	2
53	473 7007 000	Tapping Screw 4x8(S)	Black	6
●	54 461 0817 032	Space Rubber		1
●	55 461 0817 029	Space Rubber		1
●	56 417 0486 000	Mini Radiator		2
57	473 8050 001	Tapping Screw 3x30		2
58	473 7500 044	Tapping Screw 3x8	Black	2
★	009 0093 014	13P FFC Cord		1
★	009 0094 000	15P FFC Cord		1
★	205 6379 010	11P EH Conn. Cord		1
★	204 0360 009	6P PH-PH Conn. Cord		1
★	209 0294 031	17P FFC Cord		1
★	204 6425 003	15P IL-S Conn. Cord		1
★	009 0092 002	7P FFC Cord		1
★	203 4957 004	3P PH-PH Conn. Cord		1
●	273 7002 021	Tapping Screw 3x8(S)	Black	4

Ref. No.	Part No.	Part Name	Remarks	Q'ty
70	441 1593 018	Shield Sheet		1
72	477 0210 003	Push Rivet		2
73	473 7002 034	Tapping Screw 3 x 6(S)	Black	4

PACKING & ACCESSORIES
(not included EXPLODED VIEW)

Ref. No.	Part No.	Part Name	Remarks	Q'ty
	505 0038 043	Envelope		1
	511 2658 002	Operating Instruction		1
	203 0473 003	Video Cord		1
	203 6322 006	S-Video Cord		1
	204 8121 004	2P Pin Cord		1
	399 0206 005	Remote Control Unit	RC-520	1
	509 0045 009	Card Board		1
	515 0602 007	Caution Sheet		1
	505 0131 076	Cabinet Cover		1
	503 1085 109	Cushion		2
	502 0834 002	Pad		2
	501 1702 143	Carton Case		1

EXPLODED VIEW

1 2 3 4 5 6 7 8

MAIN UNIT

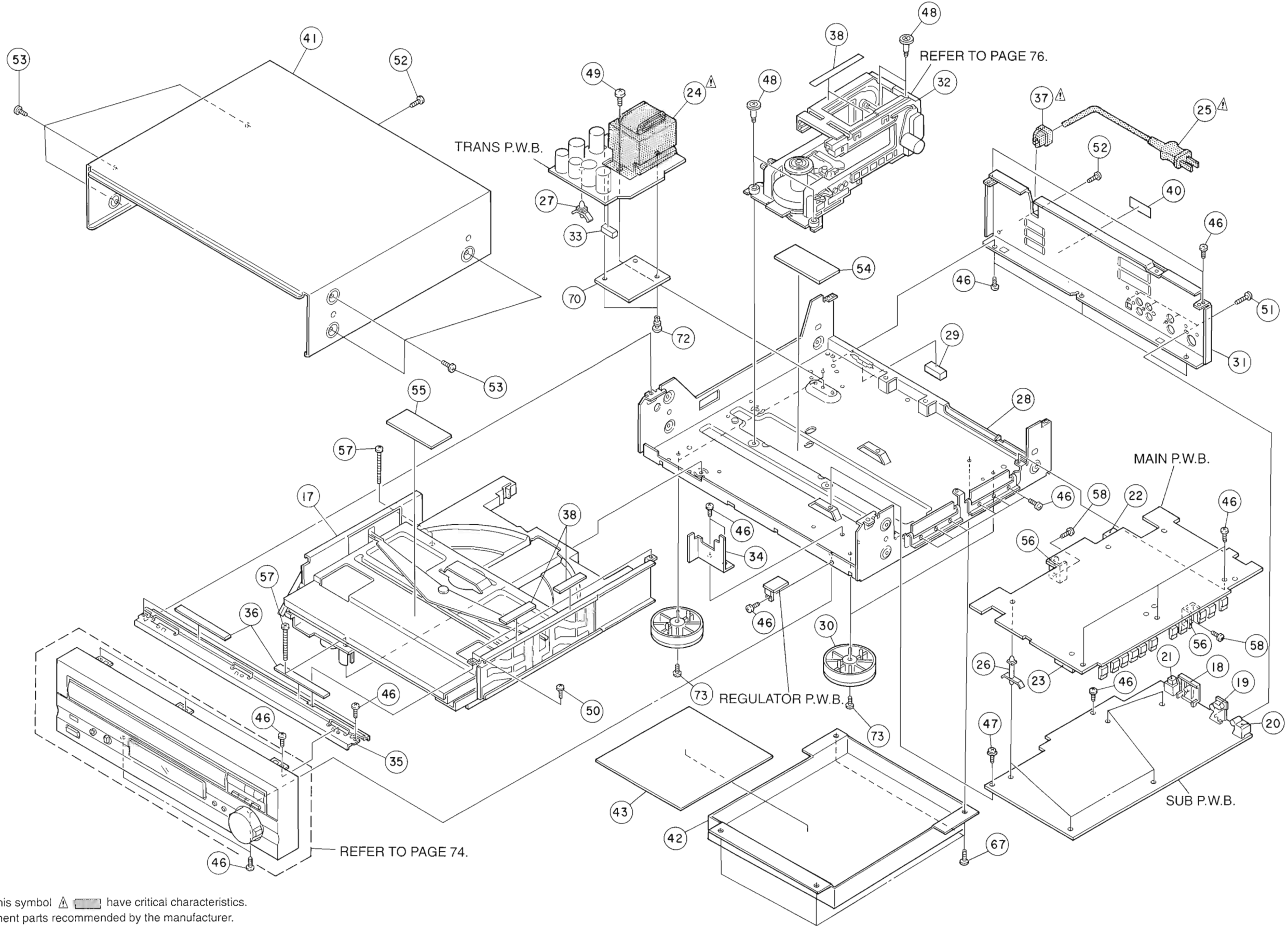

WARNING:
 Parts marked with this symbol  have critical characteristics.
 Use ONLY replacement parts recommended by the manufacturer.

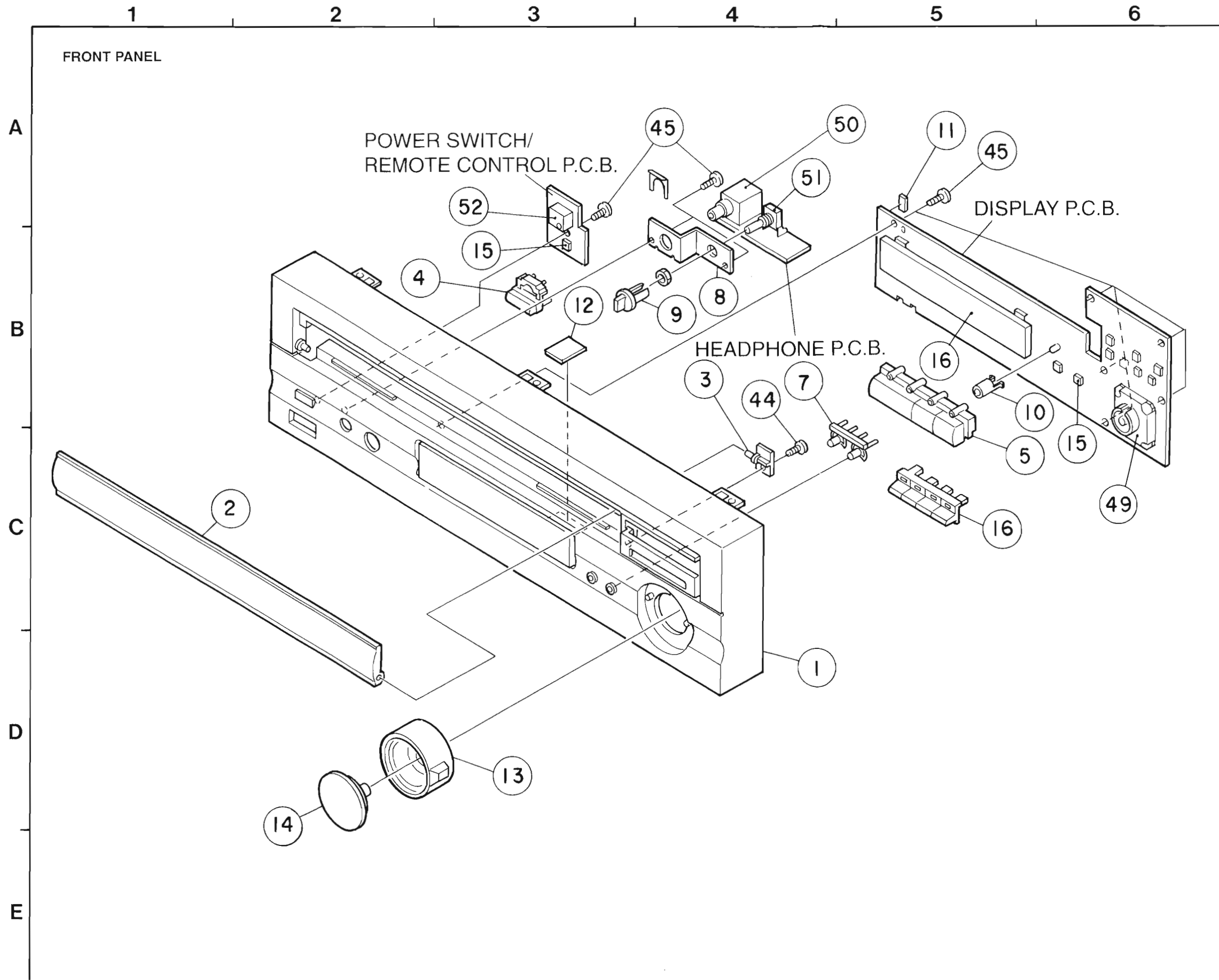

FRONT PANEL SECTION

Ref. No.	Part No.	Part Name	Remarks	Q'ty
1	103 1607 413	Front Panel Ass'y		1
2	146 1463 515	Loader Panel Ass'y		1
3	446 0043 205	Loader Panel Guide		1
4	113 1396 035	Power Button		1
5	113 1599 010	Function Button(A)	3KEY	1
6	113 1600 116	Function Button(B)	4KEY	1
7	113 1602 017	2P Button		1
8	412 3679 000	Head Phone Jack Bracket		1
9	112 0733 010	Volume Knob		1
10	443 8568 107	LED Holder		1
11	461 0598 034	Insulating Rubber		1
12	461 0812 008	Spacer		1
13	112 0732 215	Shuttle Ring		1
14	112 0731 119	Jog Dial		1
15	212 4388 907	Tact Switch		10
16	393 8003 008	FL Tube	FIP7BCM8	1
44	473 7505 010	Screw 2.6x6	CBTS(P)	1
45	473 7508 017	Screw 3x10 (B)	CBTS(P)-B	9
49	219 0013 002	Jog Shuttle Switch		1
50	204 8322 007	Headphone Jack		1
51	211 0764 001	Variable	H/P Level	1
52	499 0150 008	Remote sensor	SBX1610-52	1

TRAY/DRIVE SECTION

Ref. No.	Part No.	Part Name	Remarks	Q'ty
1	412 3637 408	Drive Base Ass'y		1
2	GEN 0158	Loading Motor Sub Ass'y		1
3	424 0184 009	Pulley Gear		1
4	424 0185 105	Gear (A)		1
5	424 0186 104	Control Gear		1
6	424 0188 005	Gear (B)		1
7	412 3641 300	Tray Guide (L)Ass'y		1
8	424 0187 200	Gear (C)		1
9	431 0336 208	Slide Cam(L)		1
10	431 0337 207	Cam Stopper		1
11	412 3643 104	Slide Guide Plate		1
12	412 3644 307	Tray Guide (R)Ass'y		1
13	431 0338 206	Slide Cam (R)		1
14	431 0339 108	Charge Plate		2
15	431 0350 417	Tray Ass'y		1
16	412 3742 005	Tray Bracket		1
17	424 0189 101	Joint Gear Ass'y		1
18	412 3646 402	Clamp Plate Ass'y		1
19	433 0586 203	Connect Plate		1
20	337 0024 001	Clamper	VXQ0222-P	1
21	337 0025 110	Hanger	VXQ0226-P	1
22	461 0807 110	Spacer		2
23	425 0239 012	Thrust Bearing		1
24	423 0066 001	Belt		1
25	2U-2572	Switch Unit		1
26	421 0640 007	Switch Shaft		4
27	433 0587 105	Door Arm		1
28	463 0752 009	Door Arm Spring		1
29	475 1157 033	Slit Washer T0.5		2
30	463 0751 000	Charge Spring		2
31	421 0637 007	Roller (L)		2
32	421 0638 006	Roller (S)		3
33	473 8047 001	Special Screw		1
34	473 7505 007	Tapping Screw 2.6x8		3
35	473 8050 001	Tapping Screw 3x30		2
36	473 7002 005	Tapping Screw 3x6		2
37	475 1157 046	Slit Washer T0.5		1
38	513 2244 001	Caution Label		1
39	473 7501 027	Tapping Screw 3x16		1

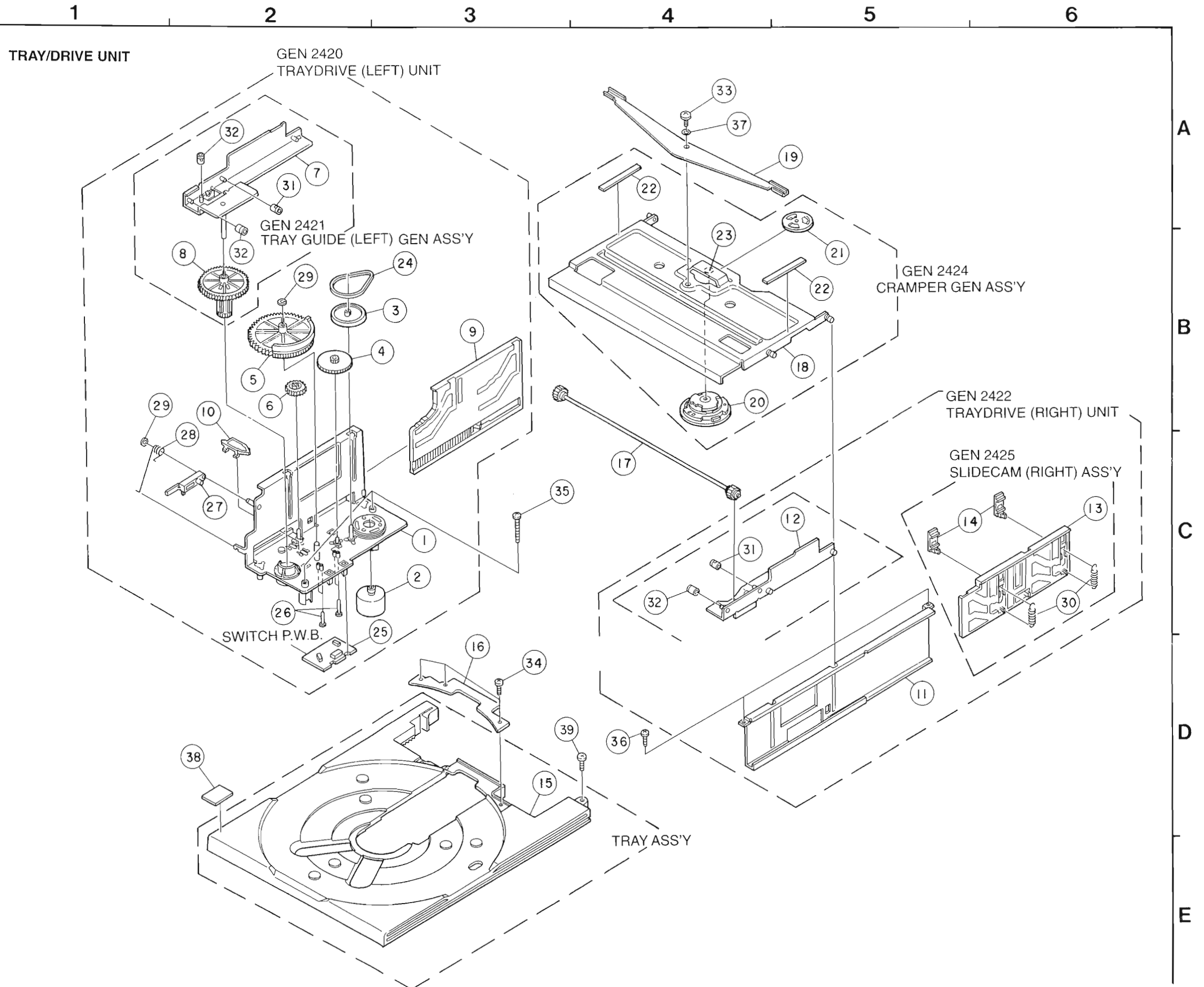

A
B
C
D
E

1 2 3 4 5 6 7 8

PICK BASE UNIT

TRAVERSE MECH

A

B

C

D

E

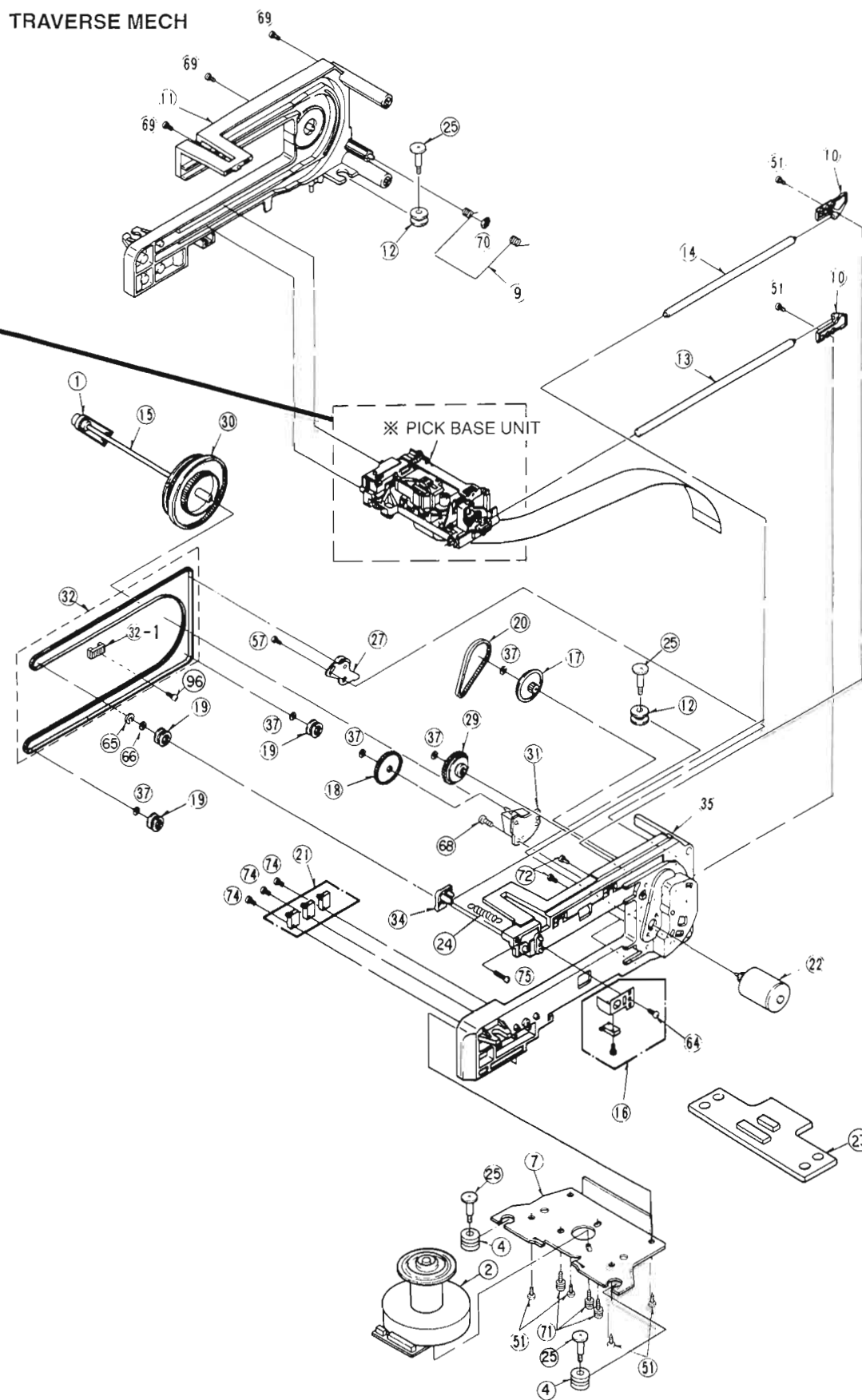
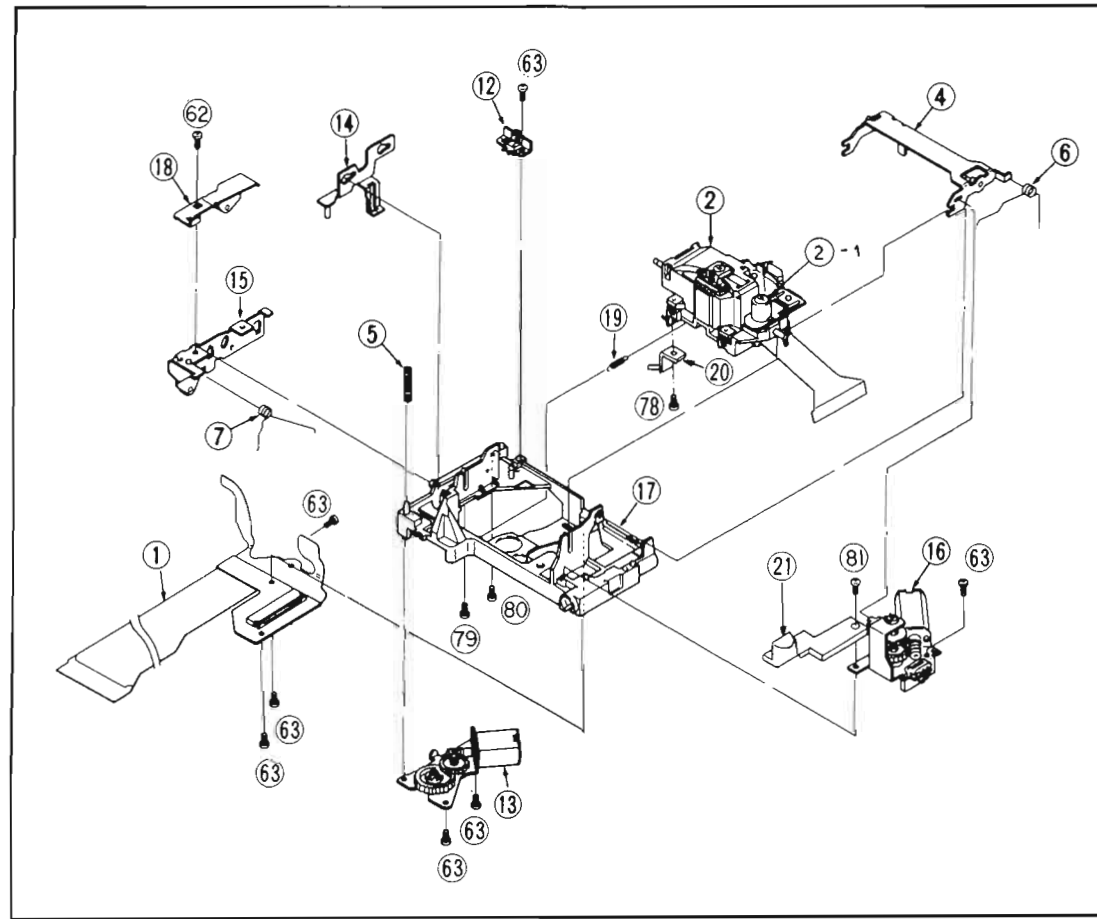

PICK-BASE SECTION

TRAVERSE MECH SECTION

Ref. No.	Part No.	Part Name	Remarks	Q'ty	Ref. No.	Part No.	Part Name	Remarks	Q'ty
1	LA3 250K 101	Pick-Up Interface Unit		1		337 0023 002	Traverse Mech	VXY0786-P	1
2	9MS 0AD9 0A	Optical Pick-Up		1	1	9MV DP13 10	Link Pulley		1
2-1	9MG P2TD 01M	Tilt Sensor GP2TD01M		1	2	9MV EM04 41	Spindle Motor		1
4	9MV XL20 28	Height Joint Plate		1	4	9MV MG07 30	Floating Rubber(B)		2
5	9MV MB21 09	Roller Adjust Spring		1	7	9MV MA87 50	Motor Base		1
6	9MV MB21 10	Height Coil Spring(A)		1	9	9MV MB21 17	Flex. Cable Hold Spring		1
7	9MV MB21 11	Height Coil Spring(B)		1	10	9MV MD15 34	Shaft Holder(A)		2
12	9MV XA50 38	Switch Base		1	11	9MV MD15 37	Guide Base(L)		1
13	9MV XA40 35	Tilt Motor Ass'y		1	12	9MV MG05 39	Floating Rubber(A)		2
14	9MV XA40 37	Tilt Lever		1	13	9MV MS43 05	Guide Shaft(A)		1
15	928 0041 000	Roller Base		1	14	9MV MS43 06	Guide Shaft(B)		1
16	9MV XA40 41	Height Motor Ass'y		1	15	9MV MS43 08	Link Shaft		1
17	928 0041 107	Pick-Up Base		1	16	9MV XA48 41	Switch Base Ass'y		1
18	9MV XA40 40	Roller Base B		1	17	9MV DG06 56	Pulley Gear(A)		1
19	9MV MB21 13	Tilt Tension Spring		1	18	9MV DG08 84	Transmission Gear(B)		1
20	9MV XA40 34	Tilt Angle		1	19	9MV DP13 07	Belt Roller		3
21	9MV MD19 83	Clener		1	20	9MV DV02 14	Motor Belt(A)		1
62	928 0033 144	Screw 2x3		1	21	9MV EK60 51	A Side Position Switch		1
63	928 0041 204	Screw 2x5		8	22	9MV EM04 33	Forward Motor		1
78	928 0038 136	Screw 2.6x6		1	23	9MV EK61 54	Interface Unit		1
79	9MV HD07 92	Screw		1	24	9MV MB21 15	Constriction Spring		1
80	9MV HD06 00	Screw		1	25	9MV HD07 40	Floating Screw		4
81	928 0041 217	Screw 2x7		1	27	9MV XA40 42	Tension Arm		1
					29	9MV XP11 85	Brake Gear(1)		1
					30	9MV XP13 83	Forward Belt Pulley		1
					31	9MV XQ03 26	Transmission Gear Base		1
					32	9MV XQ02 21	Forward Belt		1
					32-1	9MV MD15 36	Belt Clamper		1
					34	9MV XD01 24	Shaft Holder(B)		1
					35	9MV XK09 83	Guide Base(R)		1
					37	9MV MX14 54	Cut Washer		5
					51	928 0012 000	Screw 3x10		6
					57	473 0805 047	Screw 3x8		1
					64	928 0033 102	Screw 3x6		1
					65	928 0038 246	E Ring		1
					66	928 0038 259	Washer		1
					68	928 0041 220	Screw 2x6		3
					69	928 0033 267	Screw 3x16		3
					70	928 0033 254	E Ring		1
					71	LA1 330K 128	Screw 3x6		3
					72	928 0041 408	Screw 3x7		2
					74	928 0033 212	Screw 1.6x10		3
					75	928 0033 238	Screw 2x10		1
					96	928 0041 301	Screw 2.6x4		1

CIRCUIT BLOCK DIAGRAM

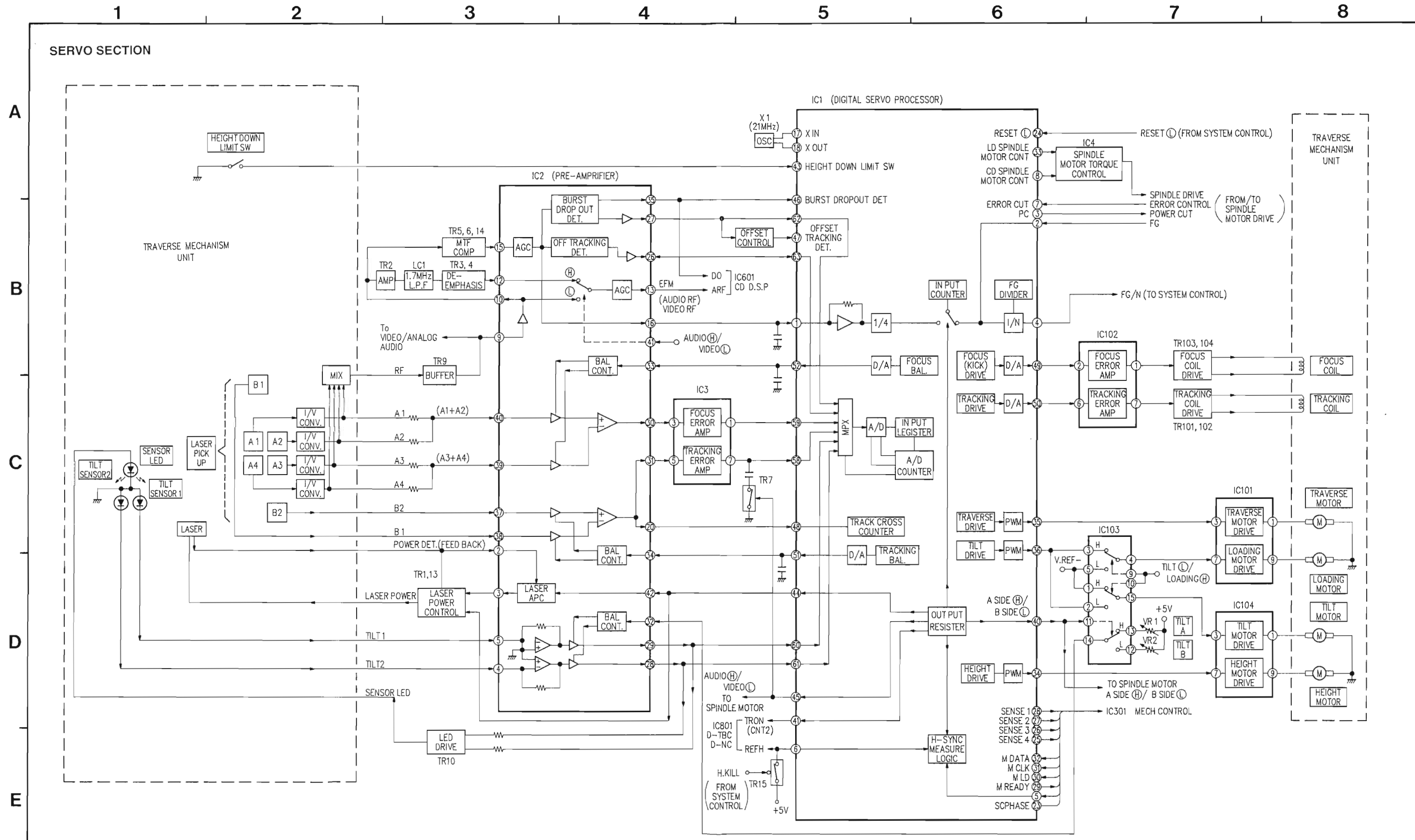

1 2 3 4 5 6 7 8

AUDIO SECTION

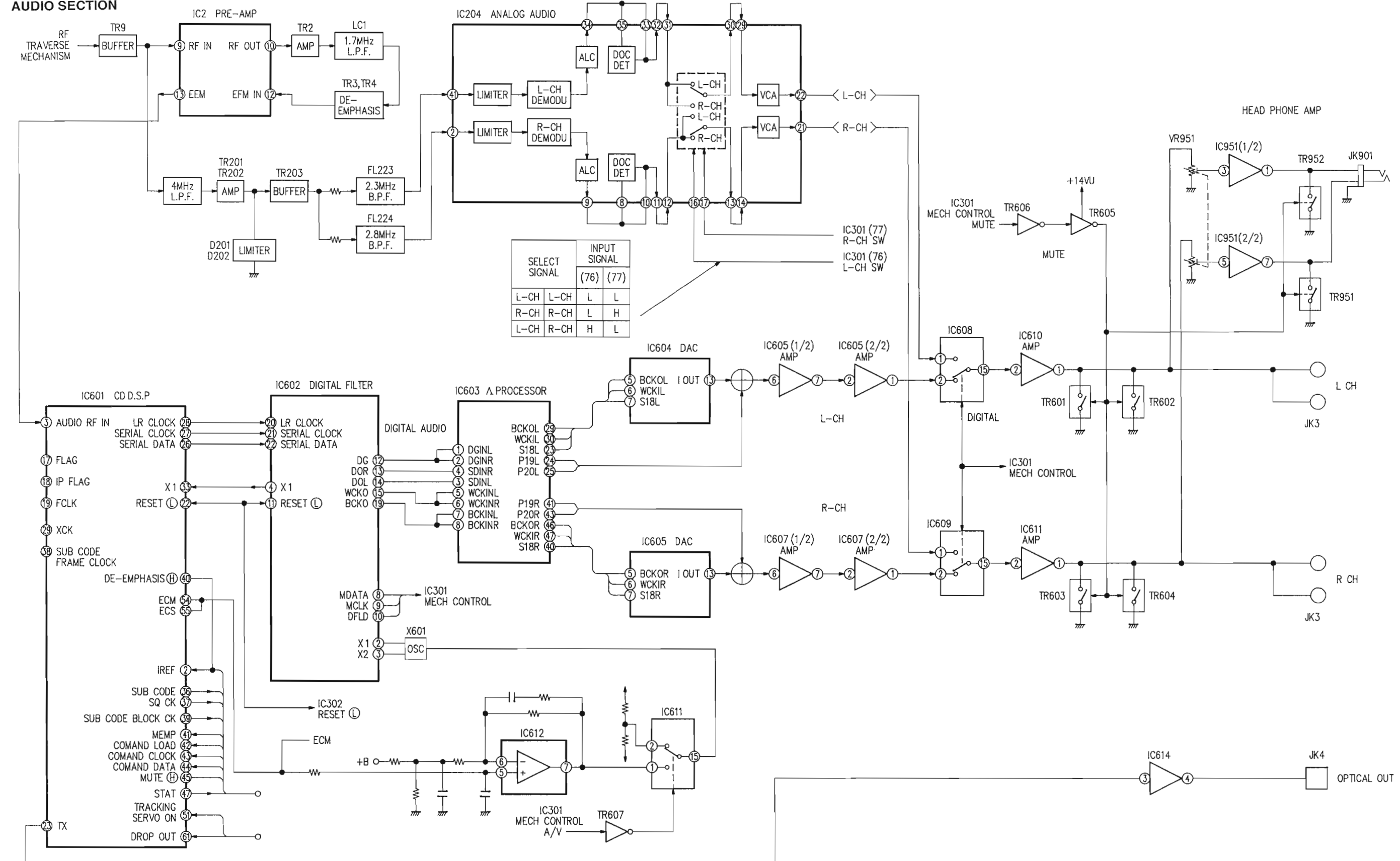

SELECT SIGNAL	INPUT SIGNAL	
	(76)	(77)
L-CH	L-CH	L
R-CH	R-CH	L
L-CH	R-CH	H
R-CH	L-CH	L

A
B
C
D
E

VIDEO SECTION

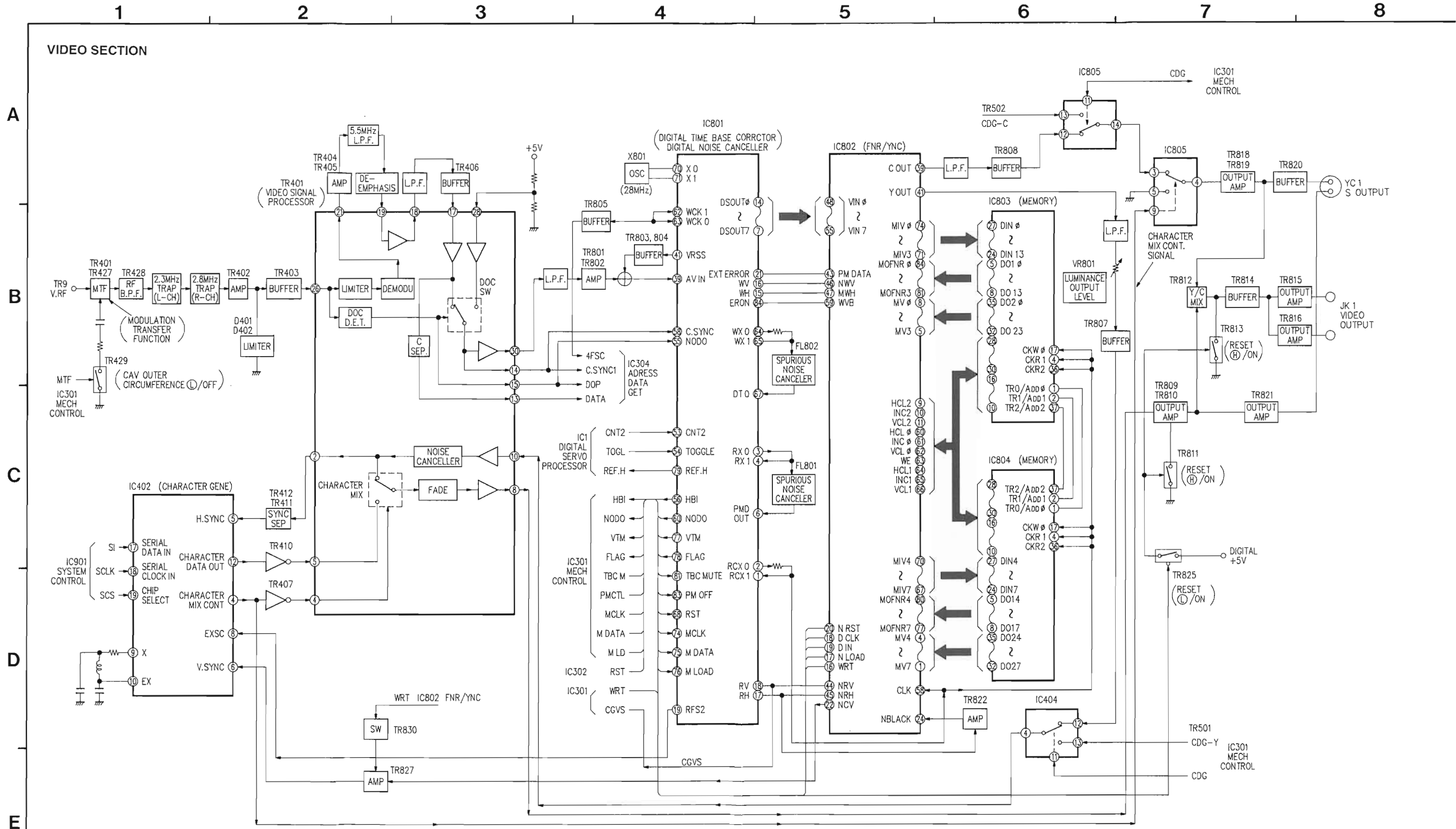

1 2 3 4 5 6 7 8

CONTROL SECTION

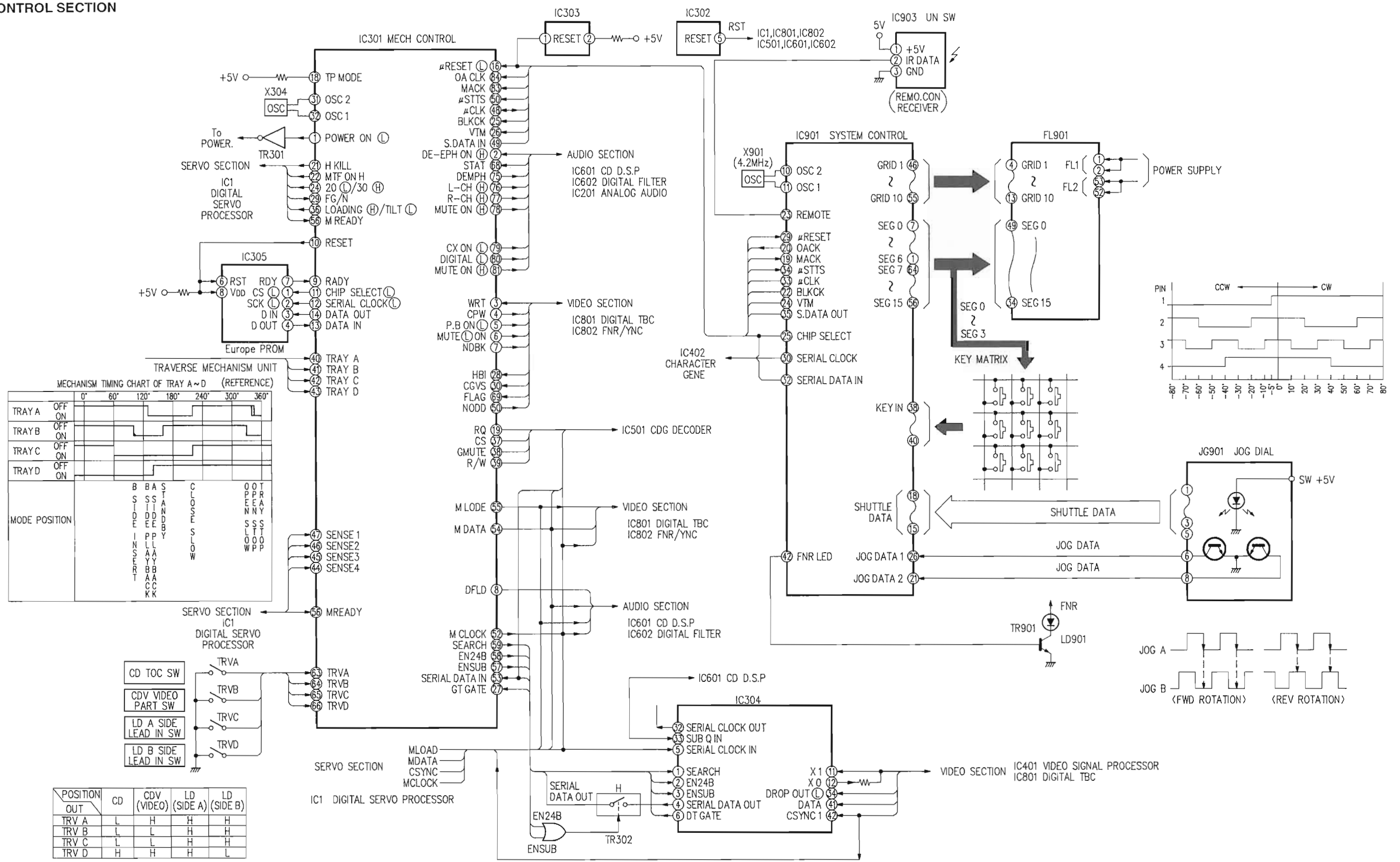

A
B
C
D
E

1 2 3 4 5 6 7 8

SPINDLE SERVO SECTION

CD-G SECTION

A

B

C

D

E

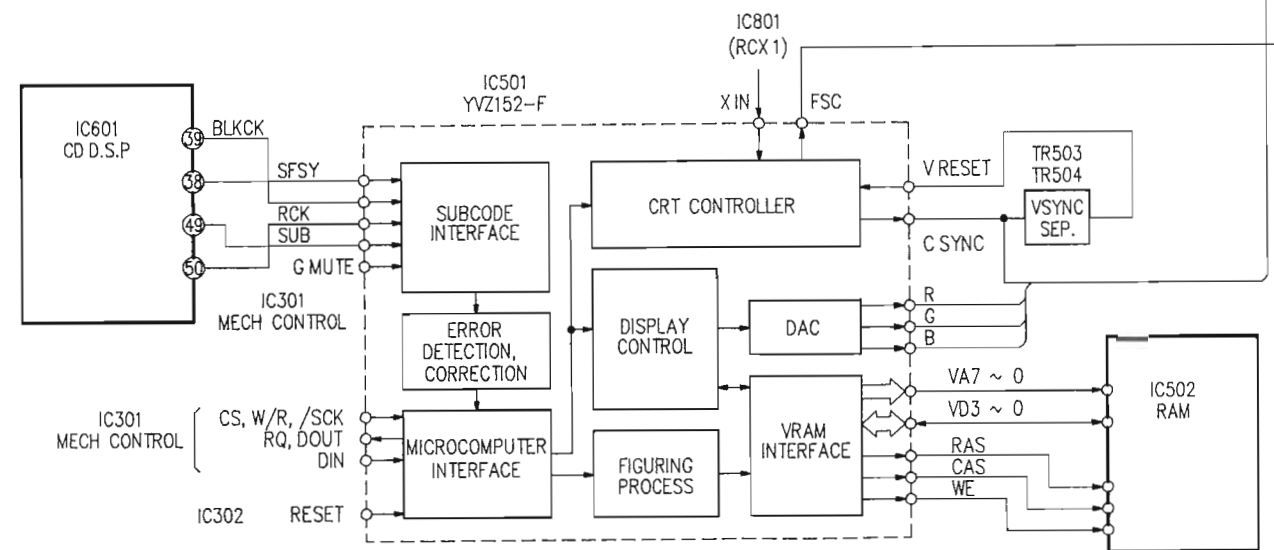
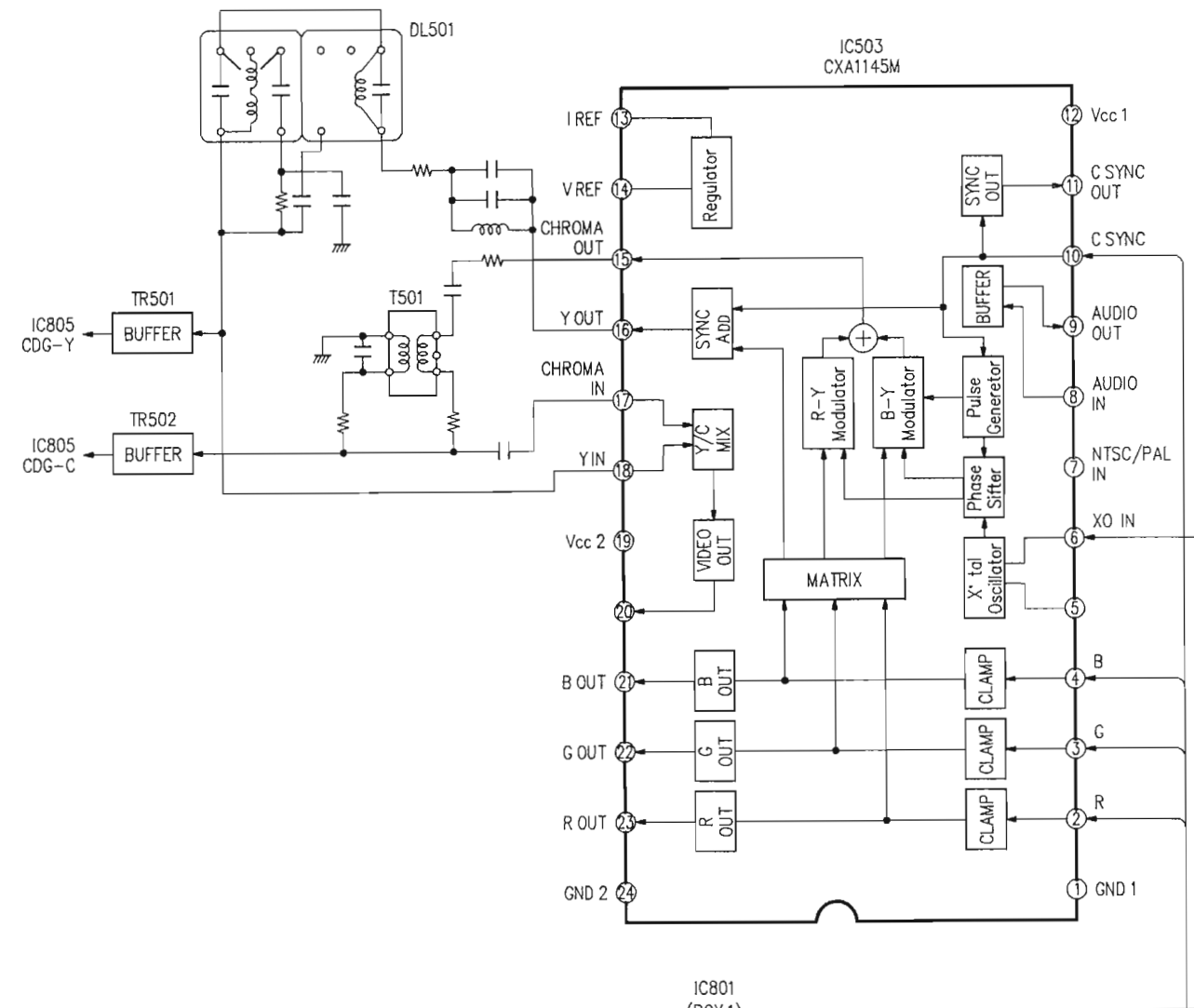
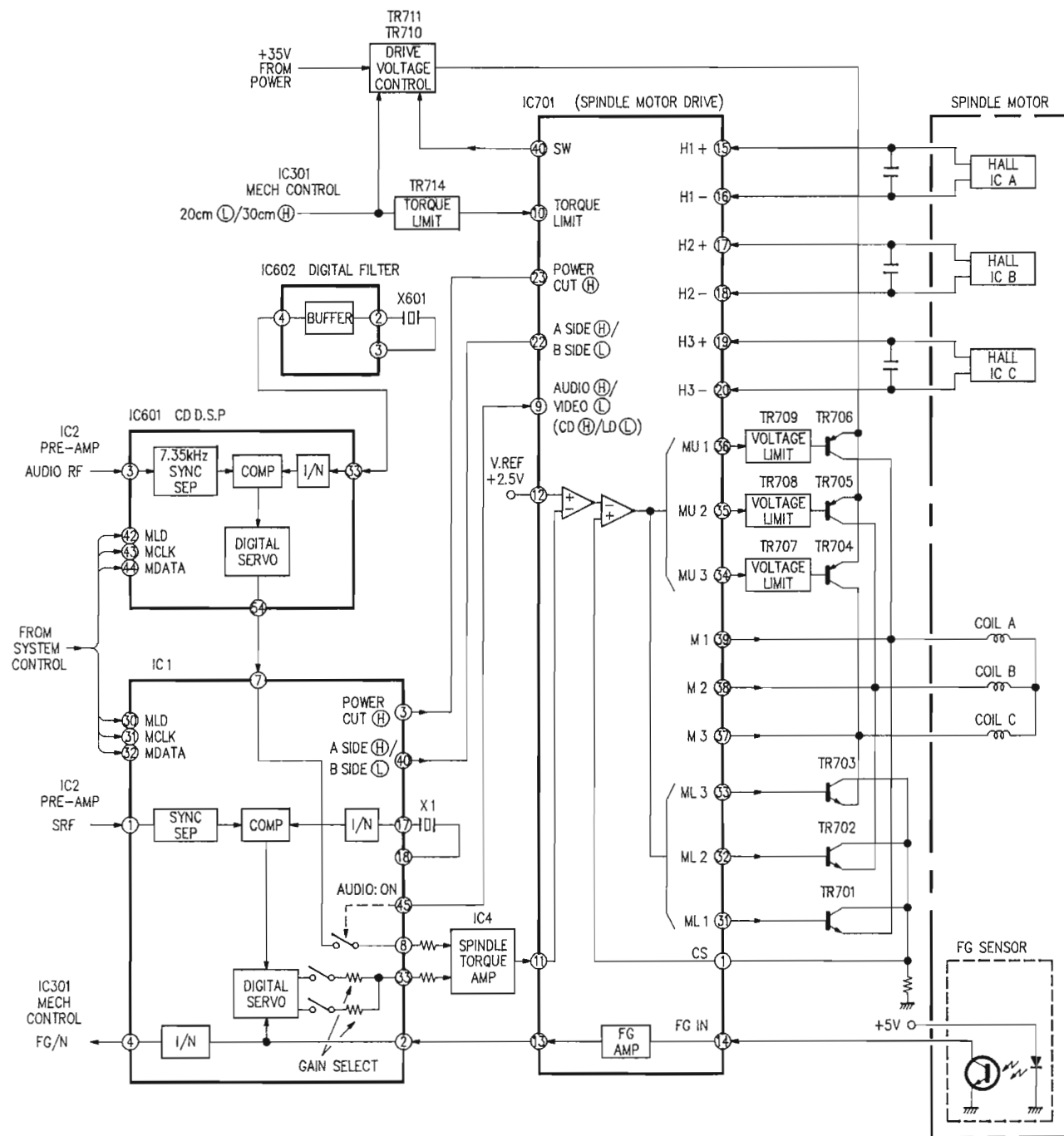

WIRING DIAGRAM

1 2 3 4 5 6 7 8

A

B

C

D

E

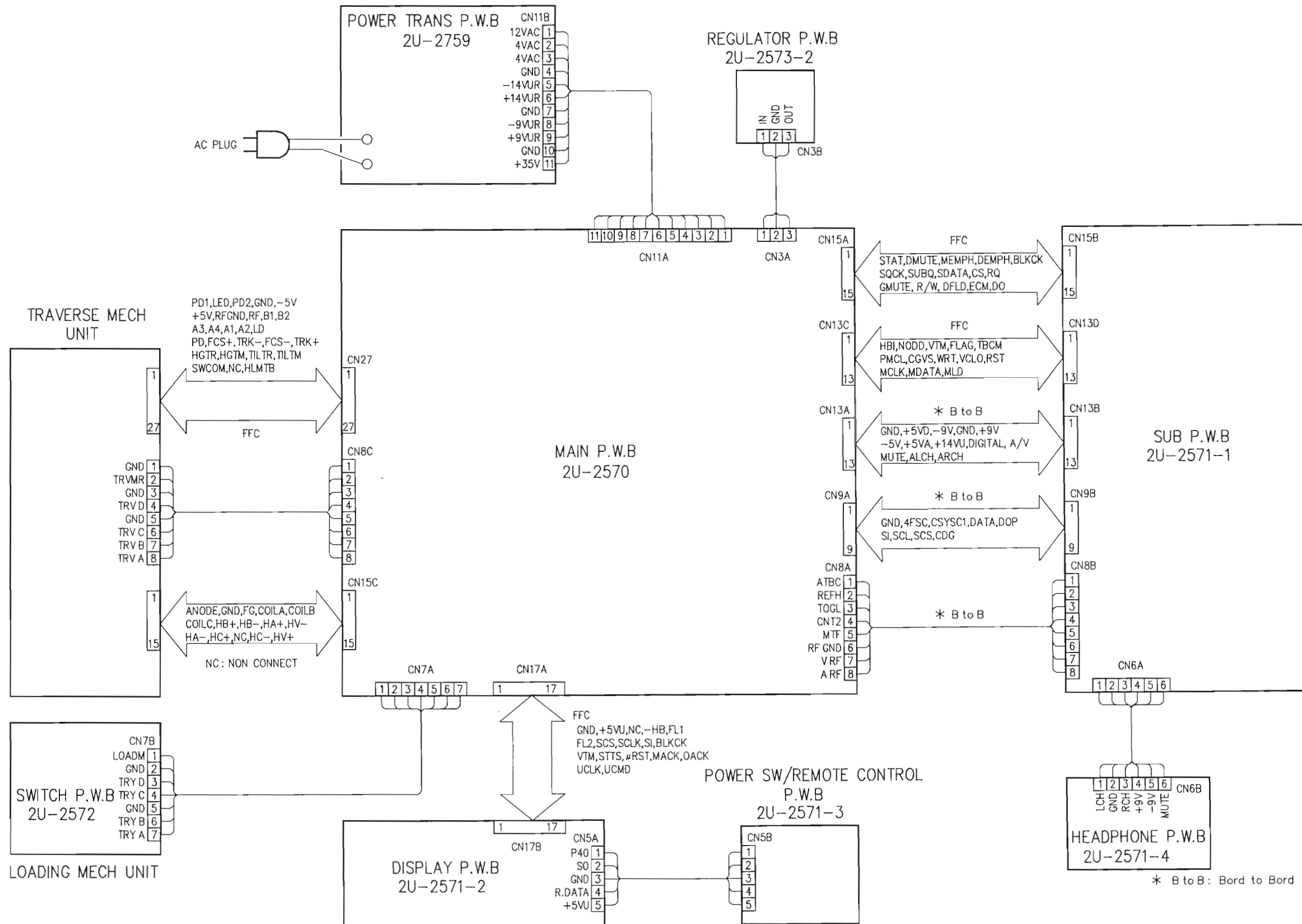



SCHEMATIC DIAGRAM

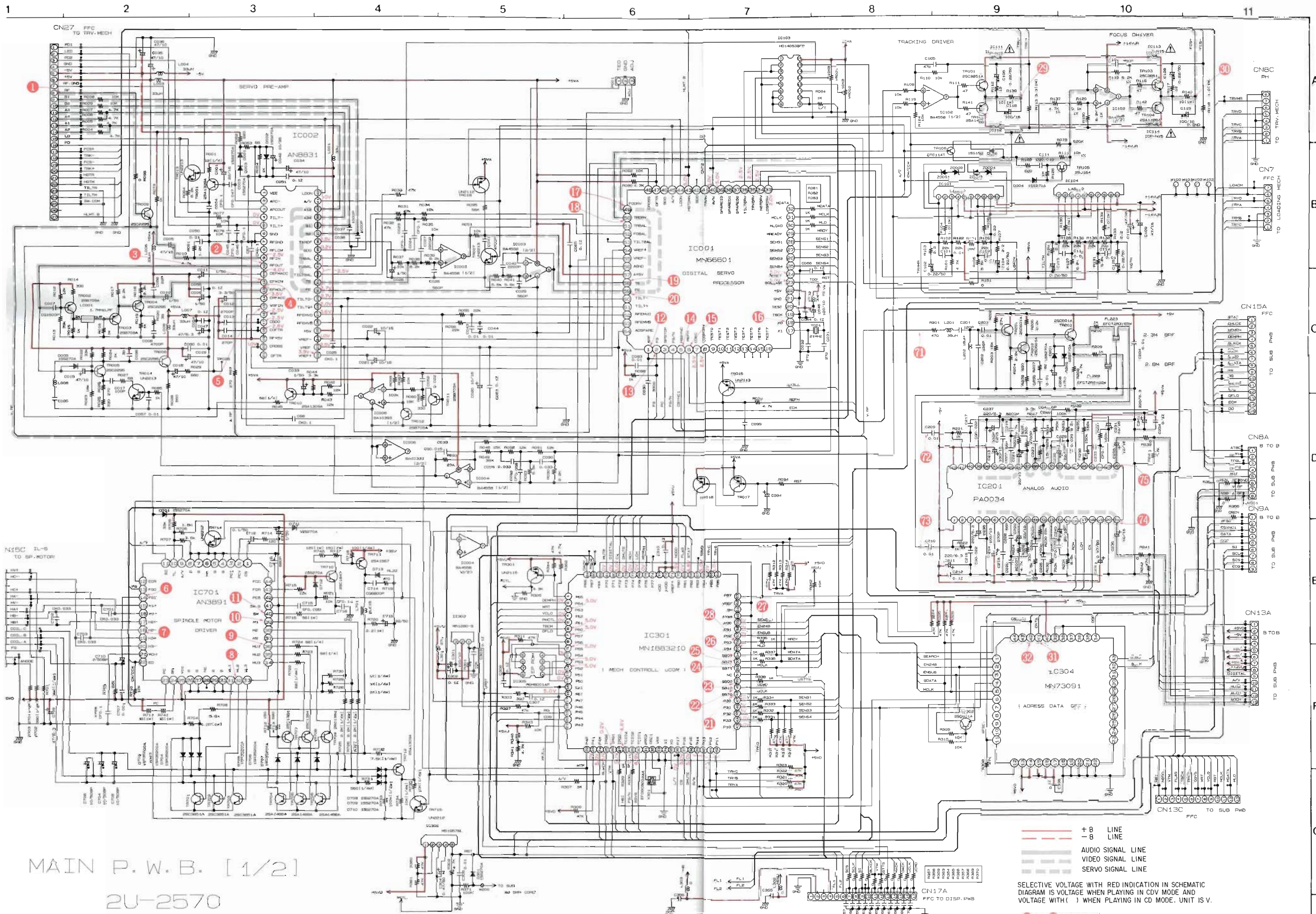

MAIN P.W.B. [1/2]
2U-2570

WARNING:
Parts marked with this symbol have critical characteristics. Use ONLY replacement parts recommended by the manufacturer.

CAUTION:
Before returning the unit to the customer, make sure you make either (1) a leakage current check or (2) a fan-to-dissipator resistance check. If the leakage current exceeds 0.5 mA or the fan-to-dissipator resistance is less than 240 kΩ, the unit is defective.

WARNING:
DO NOT return the unit to the customer until the problem is located and corrected.

NOTES:
Circuits and parts are subject to change without notice.

NOTES:
ALL RESISTANCE VALUES: R1 OHM, R1-1000 OHM, R1-10000 OHM.
ALL CAPACITANCE VALUES IN MICROFARAD (μF), PICOFARAD (pF).
C: CAPACITANCE VALUES IN MICROFARAD (μF), PICOFARAD (pF).
CACH VOLTAGE AND CURRENT ARE MEASURED AT NO SIGNAL INPUT CONDITION.
CIRCUIT AND PARTS ARE SUBJECT TO CHANGE WITHOUT PRIOR NOTICE.

SCHEMATIC DIAGRAM

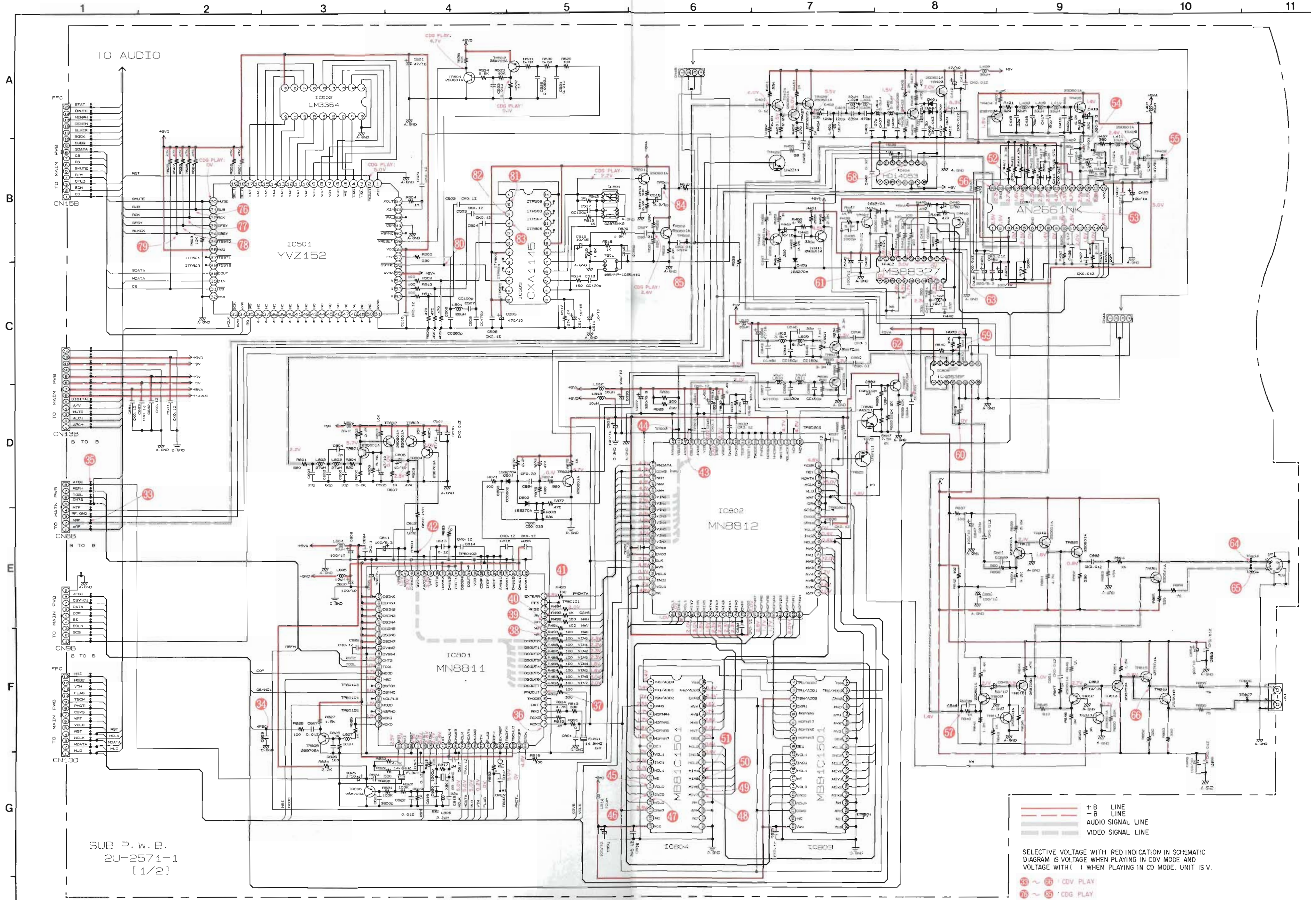

SUB P. W. B.
2U-2571-1
[1/2]

WARNING:
Parts marked with this symbol  have critical characteristics. Use ONLY replacement parts recommended by the manufacturer.

CAUTION:
Before returning the unit to the customer, make sure you make either (1) a leakage current check or (2) a line to chassis resistance check. If the leakage current exceeds 0.5 milliamperes, or if the resistance from chassis to either side of the power cord is less than 240 kilohms, the unit is defective.

WARNING:
DO NOT return the unit to the customer until the problem is located and corrected.

NOTES:
Circuit and parts are subject to change without prior notice.

NOTES:
ALL RESISTANCE VALUES IN OHM, K=1,000 OHM, M=1,000,000 OHM.
ALL CAPACITANCE VALUES IN MICRO FARAD. P=PICTO MICRO FARAD.
EACH VOLTAGE AND CURRENT ARE MEAS. (P.D.) AT NO SIGNAL INPUT CONDITION.
CIRCUIT AND PARTS ARE SUBJECT TO CHANGE WITHOUT PRIOR NOTICE.

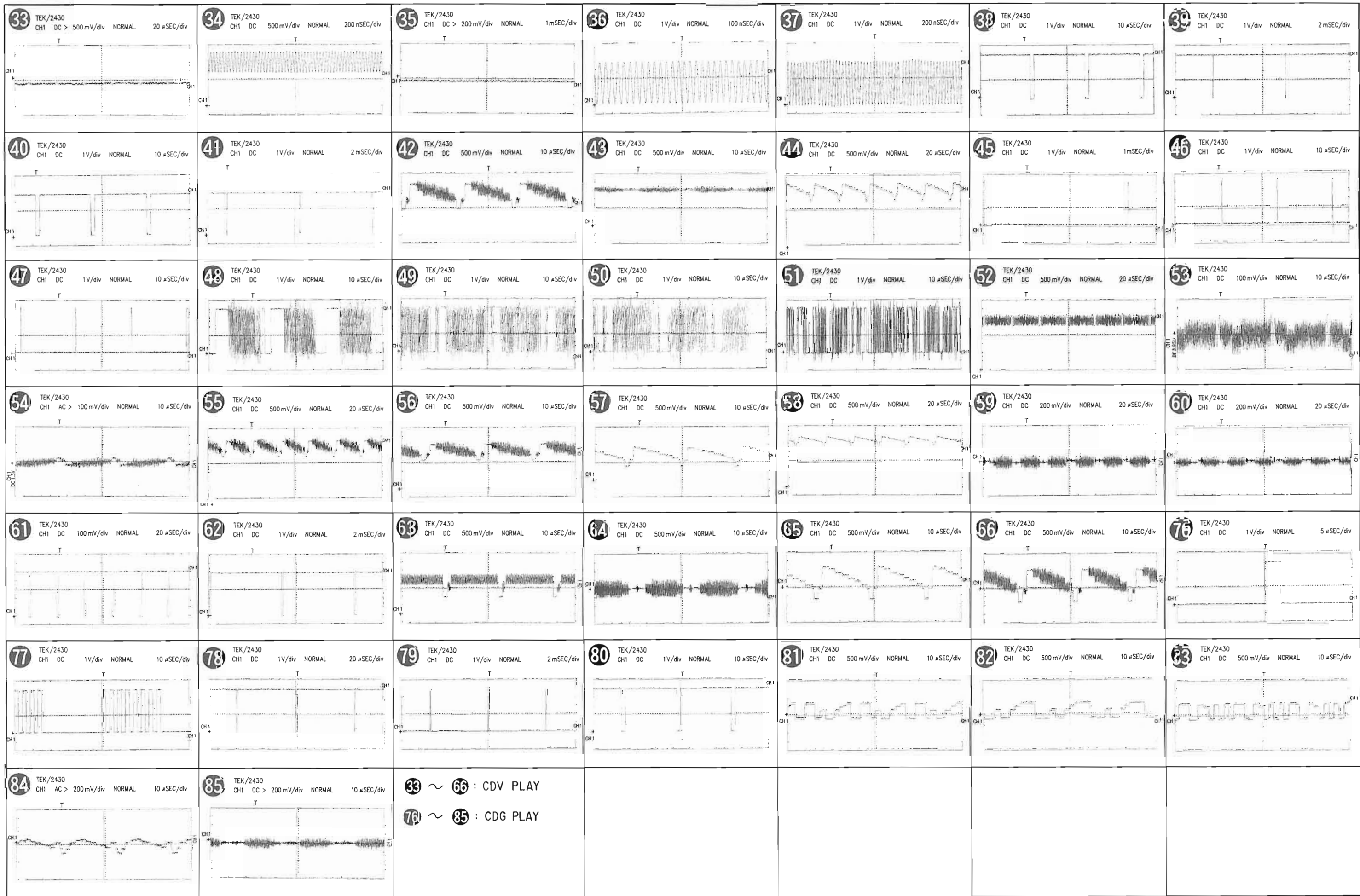

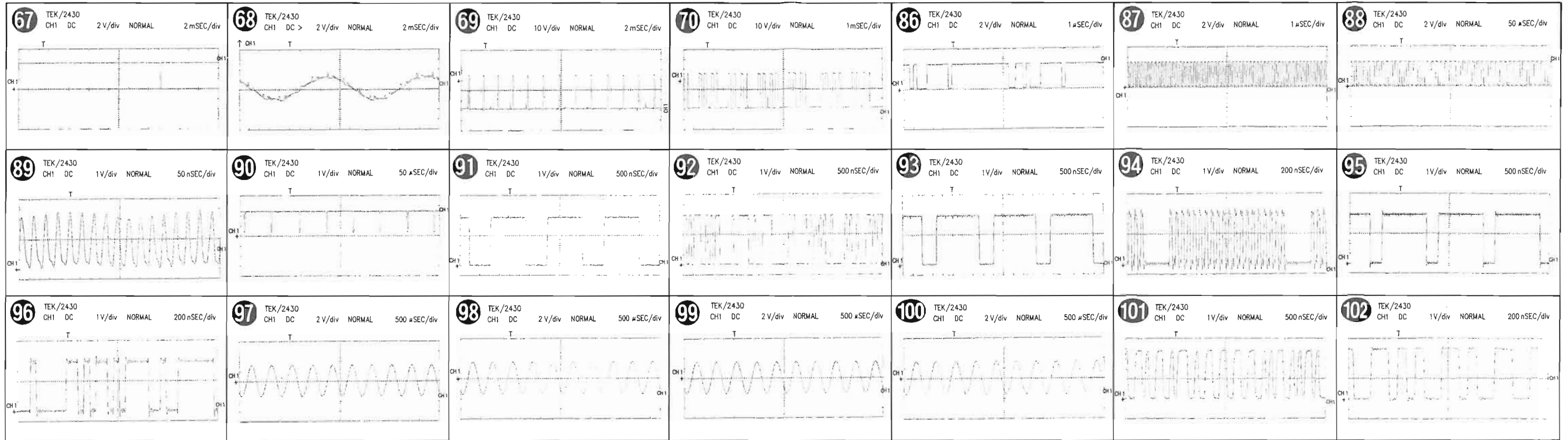



67 ~ 70 : CDV PLAY

86 ~ 102 : CD PLAY

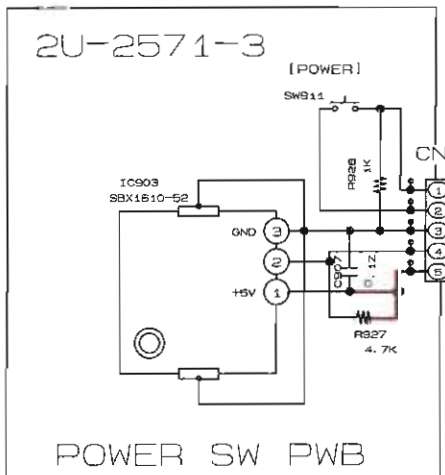
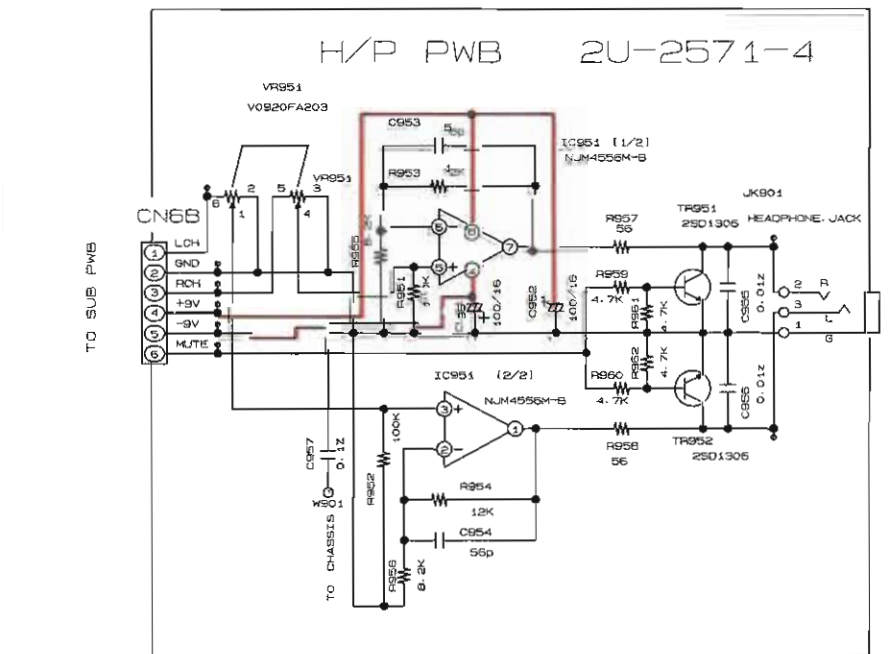
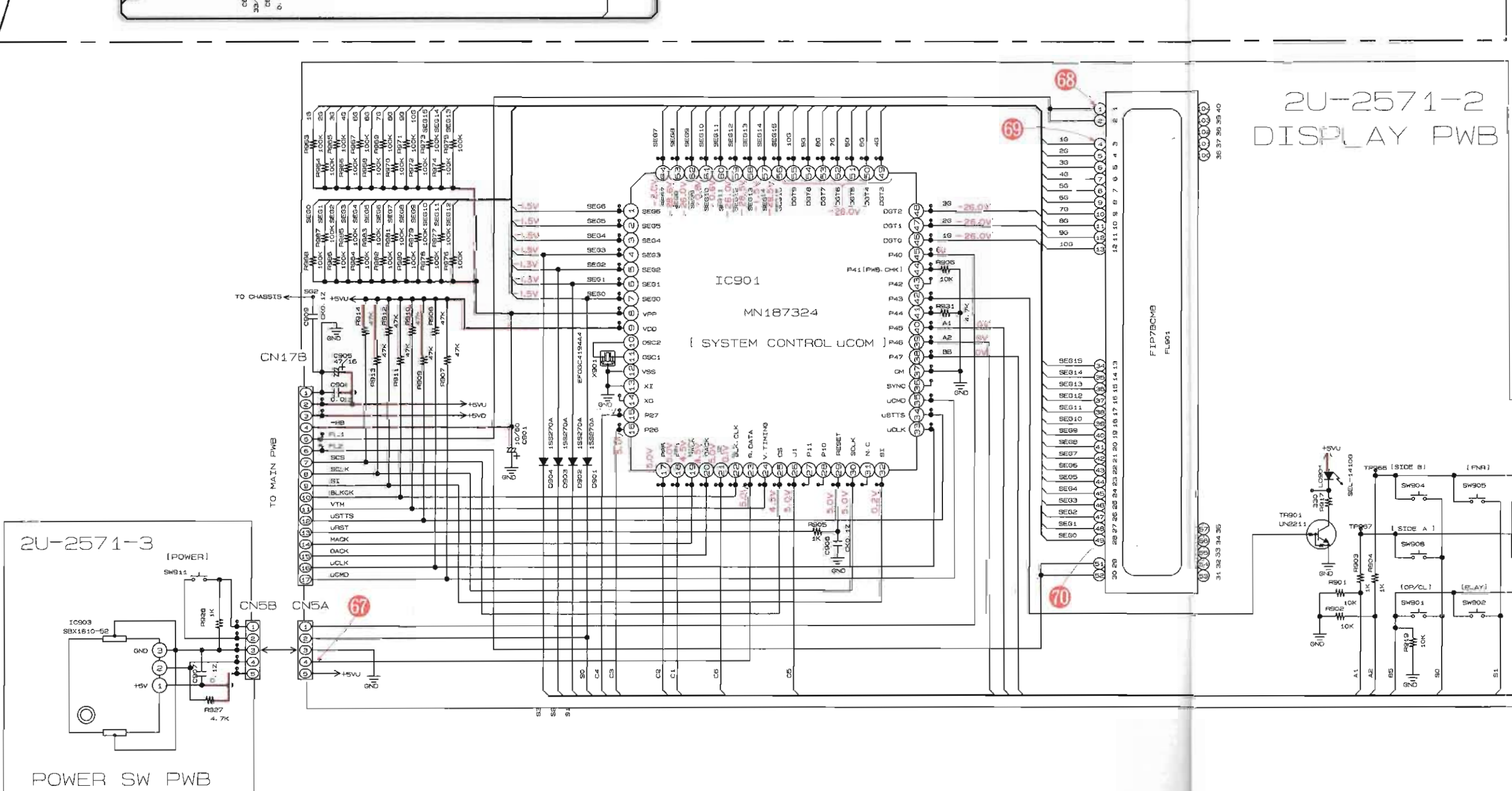
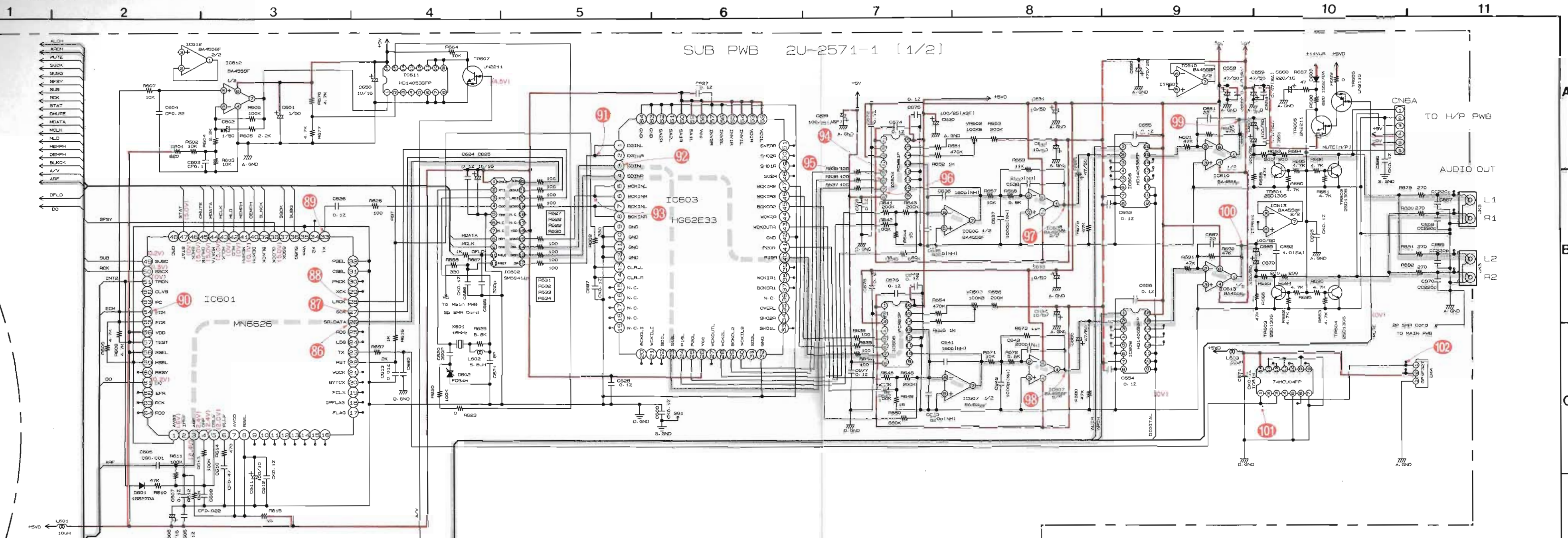
SCHEMATIC DIAGRAM



WARNING:
Parts marked with this symbol  have critical characteristics. Use ONLY replacement parts so designated by the manufacturer.

CAUTION:
Before returning the unit to the customer, make sure you make either (1) a leakage current check or (2) a line to chassis-resistance check. If the leakage current exceeds 0.5 millamps, or if the resistance from chassis to either side of the power cord is less than 240 kilohms, the unit is defective.

WARNING:
DO NOT return the unit to the customer until the problem is located and corrected.

NOTES:
Circuit and parts are subject to change without prior notice.

NOTES:
ALL RESISTANCE VALUES IN OHM, K=1,000 OHM, M=1,000,000 OHM.
ALL CAPACITANCE VALUES IN MICRO FARAD. P=MICRO-MICRO FARAD.
EACH VOLTAGE AND CURRENT ARE MEASURED AT NO SIGNAL INPUT CONDITION.
CIRCUIT AND PARTS ARE SUBJECT TO CHANGE WITHOUT PRIOR NOTICE.

1 2 3 4 5 6 7 8 9 10

A

B

C

D

E

F

G

H

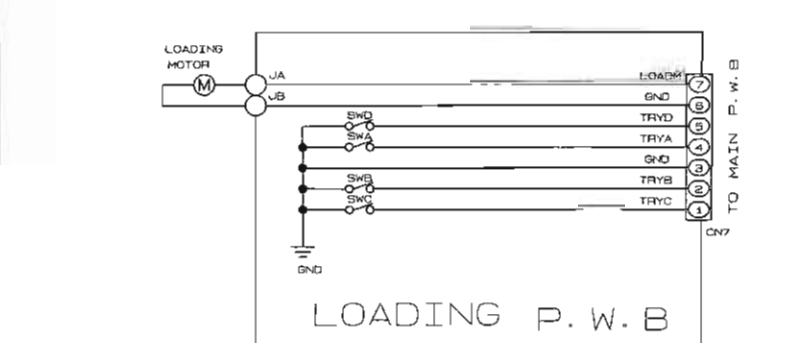
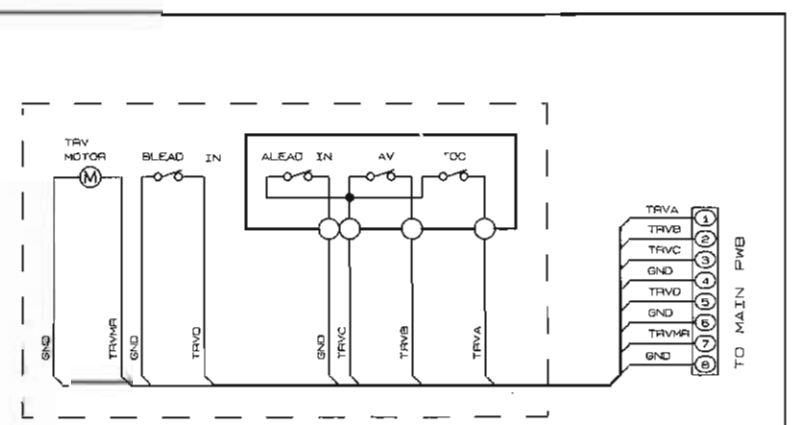
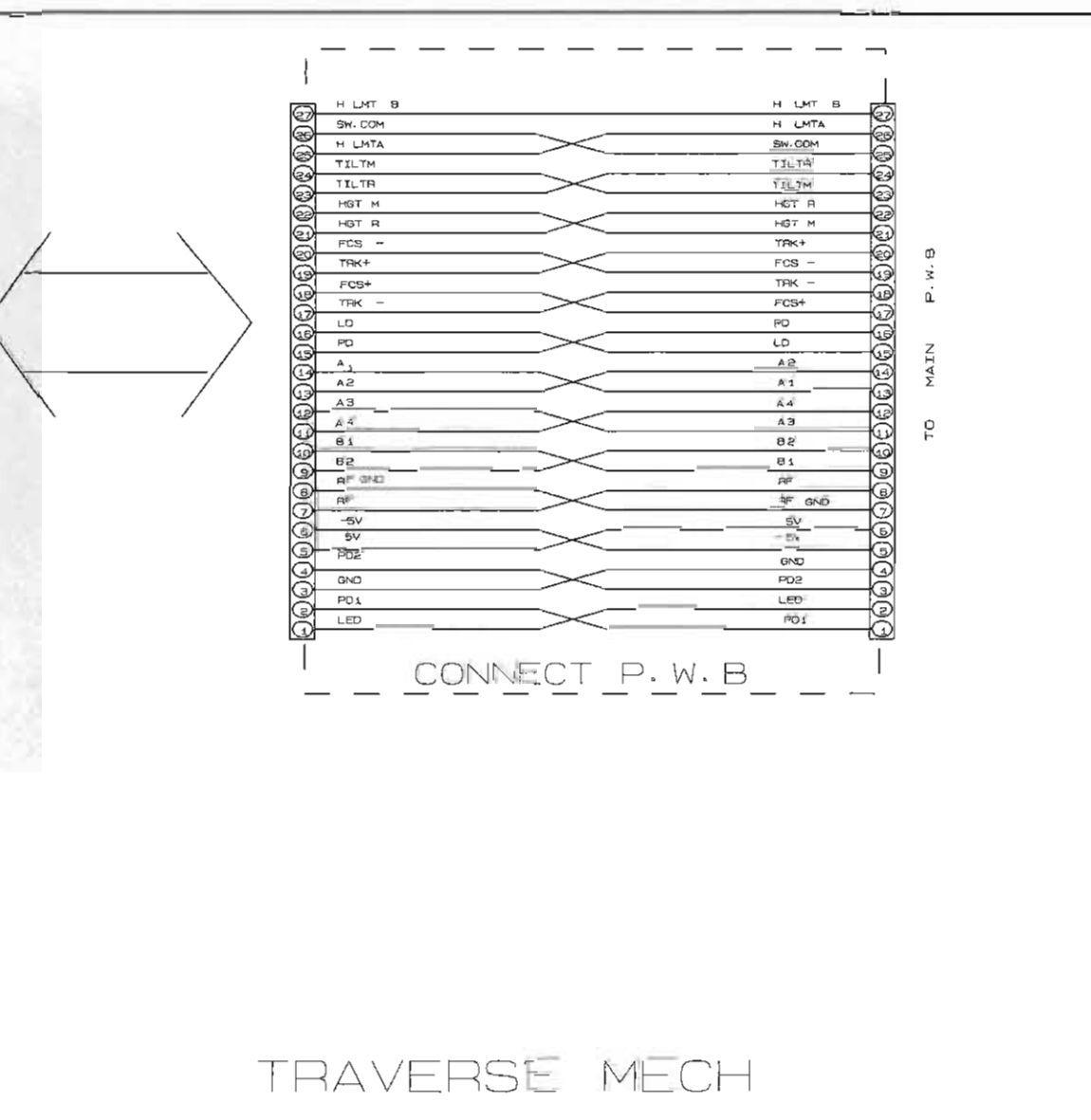
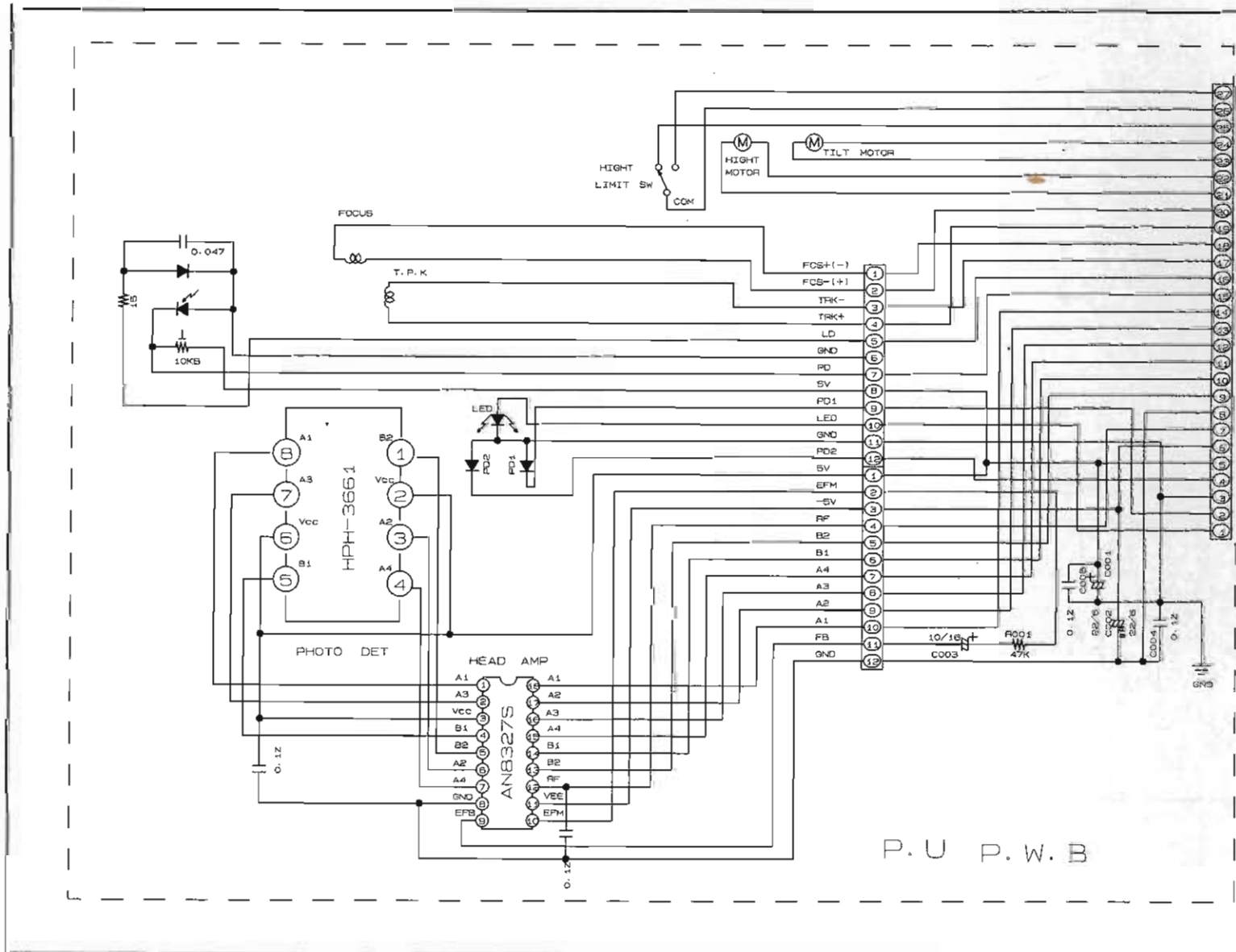
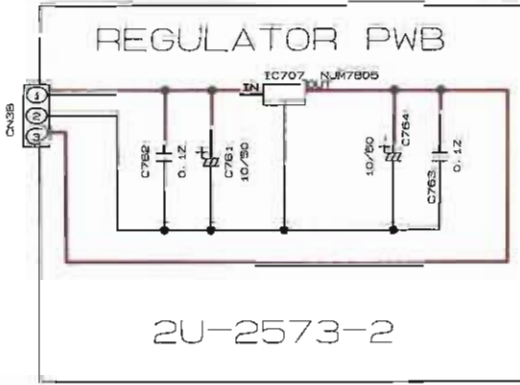
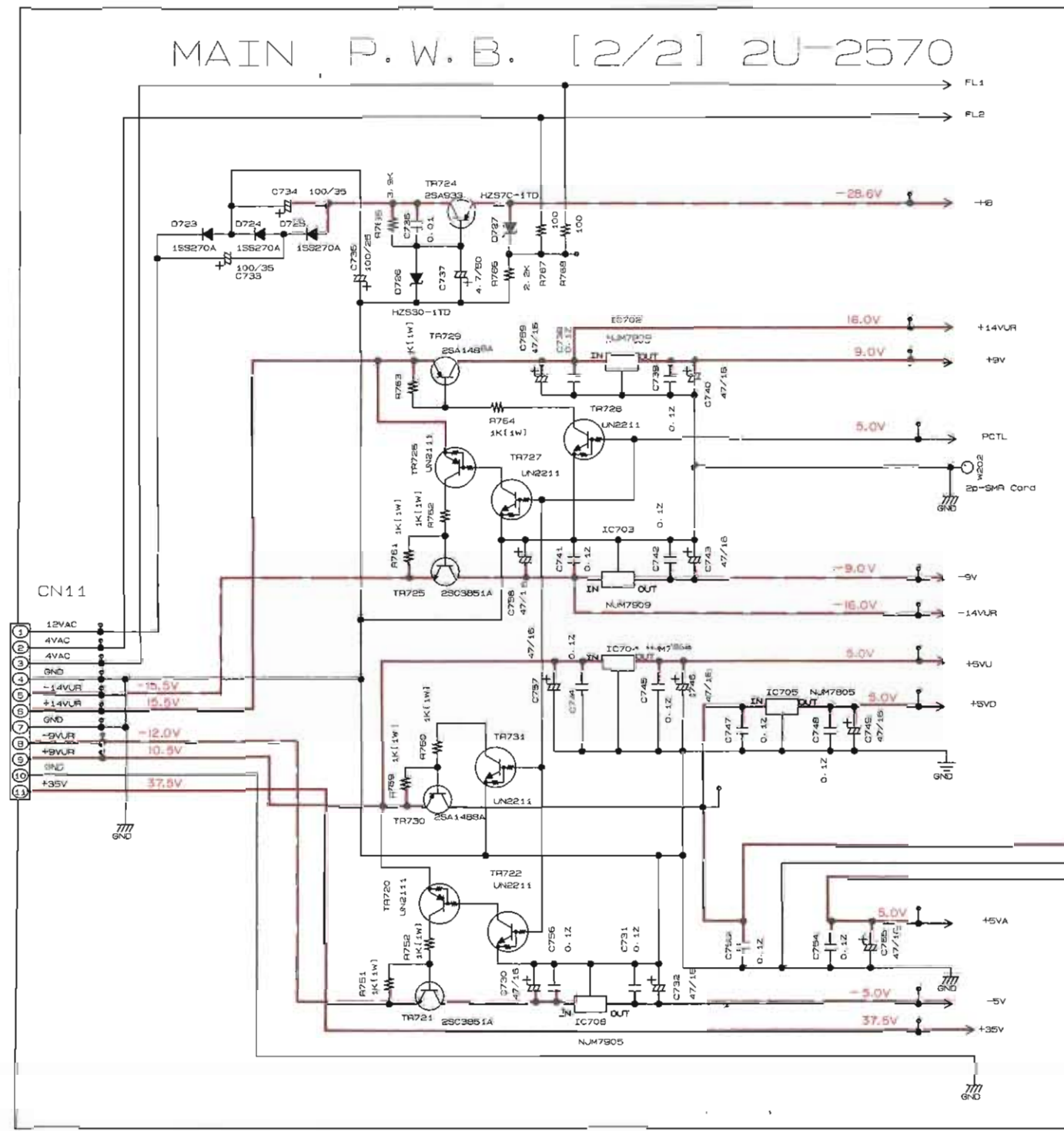
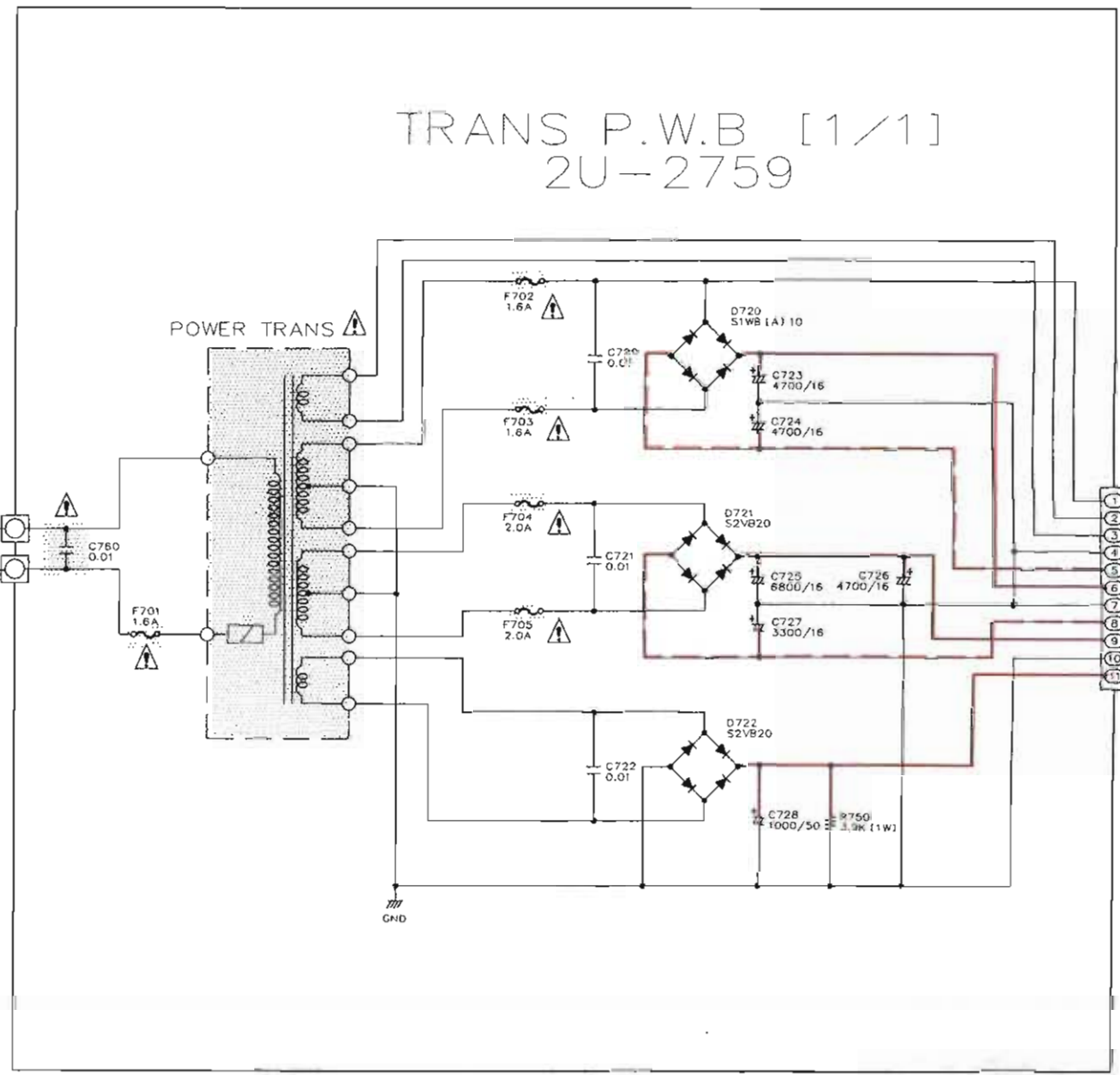

--- +B LINE
--- -B LINE

SELECTIVE VOLTAGE WITH RED INDICATION IN SCHEMATIC DIAGRAM IS VOLTAGE WHEN PLAYING IN CDV MODE AND VOLTAGE WITH () WHEN PLAYING IN CD MODE. UNIT IS V.

WARNING:
Parts marked with this symbol have critical characteristics. Use ONLY replacement parts recommended by the manufacturer.

CAUTION:
Before returning the unit to the customer, make sure you make either (1) a leakage current check or (2) a line to earth resistance check. If the leakage current exceeds 0.5 millamps, or if the resistance from chassis to either side of the power cord is less than 200 kilohms, the unit is defective.

WARNING:
DO NOT return the unit to the customer until the problem is located and corrected.

NOTES:
Circuit and parts are subject to change without prior notice.

NOTES:
ALL RESISTANCE VALUES IN OHMS UNLESS OTHERWISE SPECIFIED.
ALL CAPACITANCE VALUES IN MICRO-FARAD, PICO-FARAD OR FARAD.
EACH VOLTAGE AND CURRENT ARE MEASURED AT NO SIGNAL INPUT CONDITION.
CIRCUIT AND PARTS ARE SUBJECT TO CHANGE WITHOUT PRIOR NOTICE.

11/2

)

)

)

)

DENO

NIPPON COLUMBIA CO., LTD.

14-14, AKASAKA 4-CHOME, MINATO-KU, TOKYO 107-11, JAPAN

Telephone: 03 (3584) 8111

Cable: NIPPON COLUMBIA TOKYO Telex: JAPANOLA J22591