

DENON

Hi-Fi Integrated Stereo Amplifier

SERVICE MANUAL

MODEL PMA-1055R

INTEGRATED STEREO AMPLIFIER

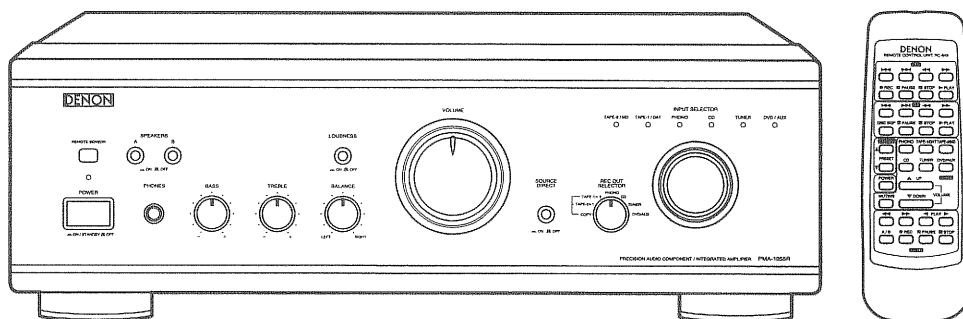

— TABLE OF CONTENTS —

SAFETY PRECAUTION	2
SPECIFICATIONS	2
DISASSEMBLY	3,4
BLOCK AND LEVEL DIAGRAM	5
ADJUSTMENT	6
SEMICONDUCTORS	7,8
PRINTED WIRING BOARD	9-11
NOTE FOR PARTS LIST	12
PARTS LIST OF P.W.B. UNIT ASS'Y	12-15
PARTS LIST OF EXPLODED VIEW	16
EXPLODED VIEW	17
WIRING DIAGRAM	18
SCHEMATIC DIAGRAM	19
PACKING VIEW	21
PARTS LIST OF PACKING & ACCESSORIES	21

• Some illustrations using in this service manual are slightly different from the actual set.

NIPPON COLUMBIA CO., LTD.

SAFETY PRECAUTIONS

The following check should be performed for the continued protection of the customer and service technician.

LEAKAGE CURRENT CHECK

Before returning the unit to the customer, make sure you make either (1) a leakage current check or (2) a line to chassis resistance check. If the leakage current exceeds 0.5 milliamps, or if the resistance from chassis to either side of the power cord is less than 460 kohms, the unit is defective.

SPECIFICATIONS

POWER AMPLIFIER SECTION

Rated Output Power:

Both channel driven 8 Ω /ohms Load: 65 W + 65 W (20 Hz to 20 kHz, T.H.D. 0.07 %)
4 Ω /ohms Load: 120 W + 120 W (DIN, 1 kHz, T.H.D. 0.7 %)

Total Harmonic Distortion:

0.01 % (-3 dB at rated output, 8 Ω /ohms) (1 kHz)

PRE AMPLIFIER SECTION

Rated Output:

150 mV (Recout terminal)

Input Sensitivity/Input Impedance:

PHONO: 2.5 mV/47 k Ω /kohms
CD, TUNER, DVD/AUX, TAPE-1/DAT, TAPE-2/MD: 150 mV/47 k Ω /kohms

RIAA Deviation:

PHONO: 20 Hz to 20 kHz \pm 0.5 dB

OVERALL CHARACTERISTICS

SN Ratio (IHF A Network):

PHONO: 86 dB (at 5 mV input) (input terminals short-circuited)
SOURCE-DIRECT: ON
CD, TUNER, DVD/AUX, TAPE-1/DAT, TAPE-2/MD: 107 dB

Frequency Response:

5Hz to 100kHz +0, -3dB

Tone Control Adjustable Range:

BASS: 100 Hz \pm 8 dB
TREBLE: 10 kHz \pm 8 dB
LOUDNESS: 100 Hz \pm 6 dB
10 kHz \pm 6 dB

OTHERS

Power Supply:

AC230 V, 50 Hz (Europe, Asia, Australia & Hong Kong Models)
AC120 V, 60 Hz (U.S.A., Canada & Taiwan R.O.C. Models)

AC Outlets:

Switched \times 3: 120 W (U.S.A., Canada & Taiwan R.O.C. Models)
100 W (Europe, Asia & Hong Kong Models)

Power Consumption:

250 W (IEC) (Europe, Asia, Australia & Hong Kong Models)
4.0 A (U.S.A., Canada & Taiwan R.O.C. Models)
2 W MAX (Standby)

Dimensions:

434 (W) \times 144 (H) \times 347 (D) mm (17-3/32" \times 5-43/64" \times 13-21/32")

Net Mass:

9.9 kg (21 lbs 13 oz)

REMOTE CONTROL UNIT (RC-843)

Remote Control System:

Infrared pulse system

Power Supply:

3 V DC, Two size R6P ("AA") dry cell batteries

External dimensions:

54 (W) \times 155 (H) \times 29 (D) mm (2-1/8" \times 6-7/64" \times 1-1/64")

Mass:

100 g (Approx. 3.5 oz) (including batteries)

* Maximum dimensions include controls, jacks, and covers.
(W) = width, (H) = height, (D) = depth

* For improvement purposes, specifications and functions are subject to change without advanced notice.

DISASSEMBLY

(Follow the procedure below in reverse order when reassembling)

Top Cover

Remove 4 screws ① on both sides, 3 screws ② on the rear, then detach the Top Cover.

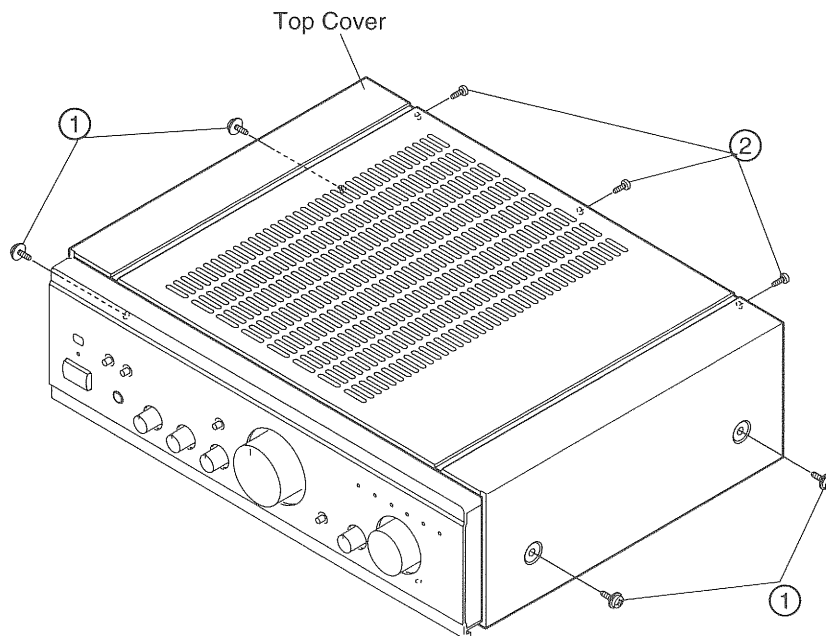

Front Panel

Remove 6 screws ③, 1 screw ④ on upper and lower edges of the Front Panel, then detach it.

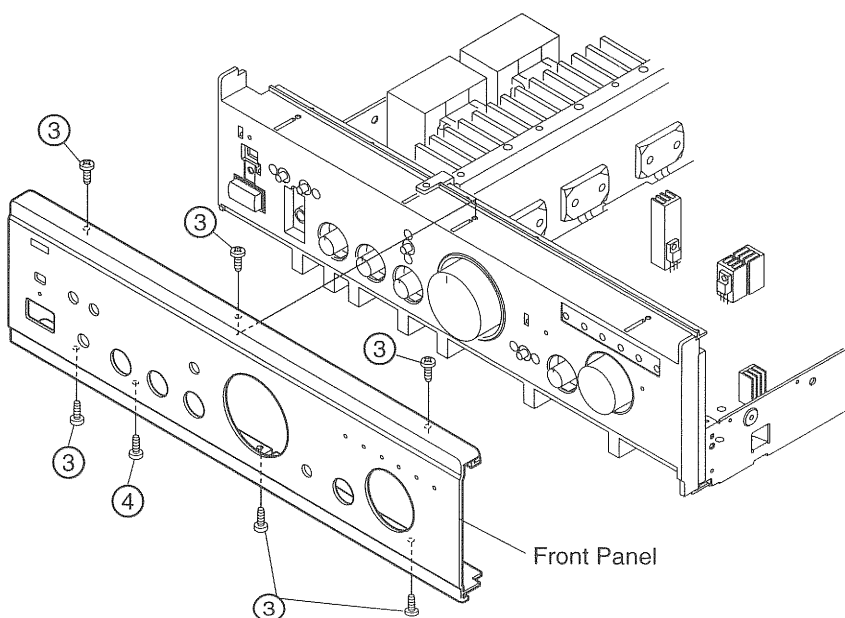

Inner Panel

1. Take off 6 knobs, 6 nuts, and 1 hold plate.
2. Remove 6 screws (5) fixing each P.W.B.
3. Remove 1 screws (6).
4. Remove 2 screws (7).

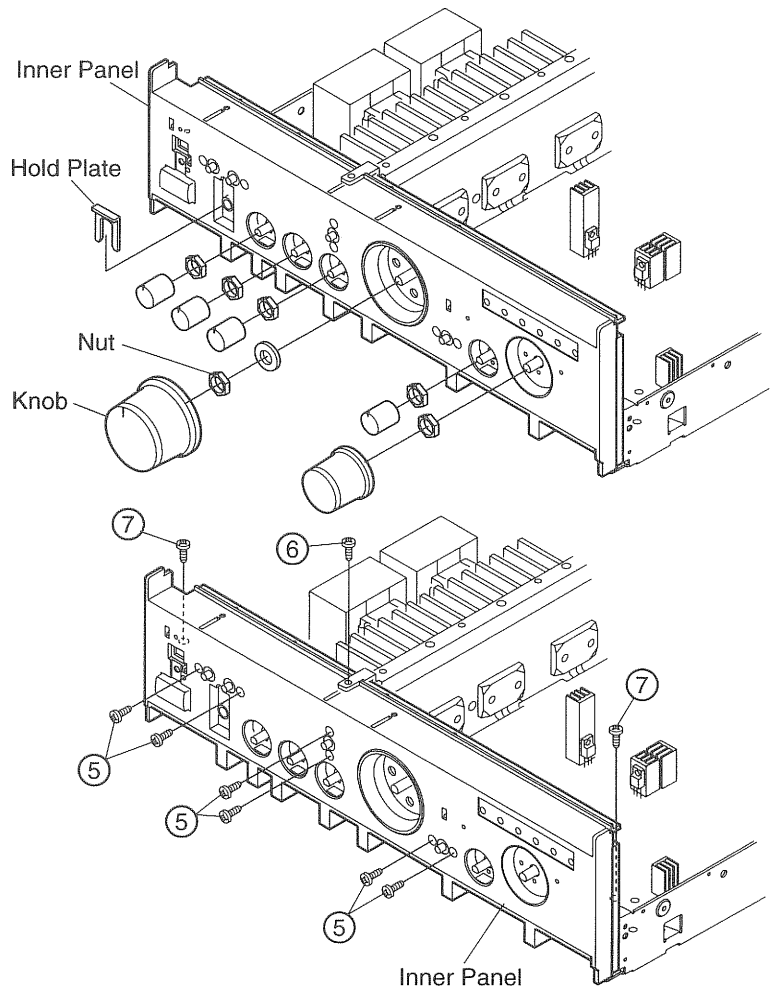

Main P.W.B.

1. Remove 2 screws (8) on the bottom.
2. Remove 1 screw (9), 12 screws (10) on the rear, then detach the Main P.W.B. and Heat sink in the arrow direction.

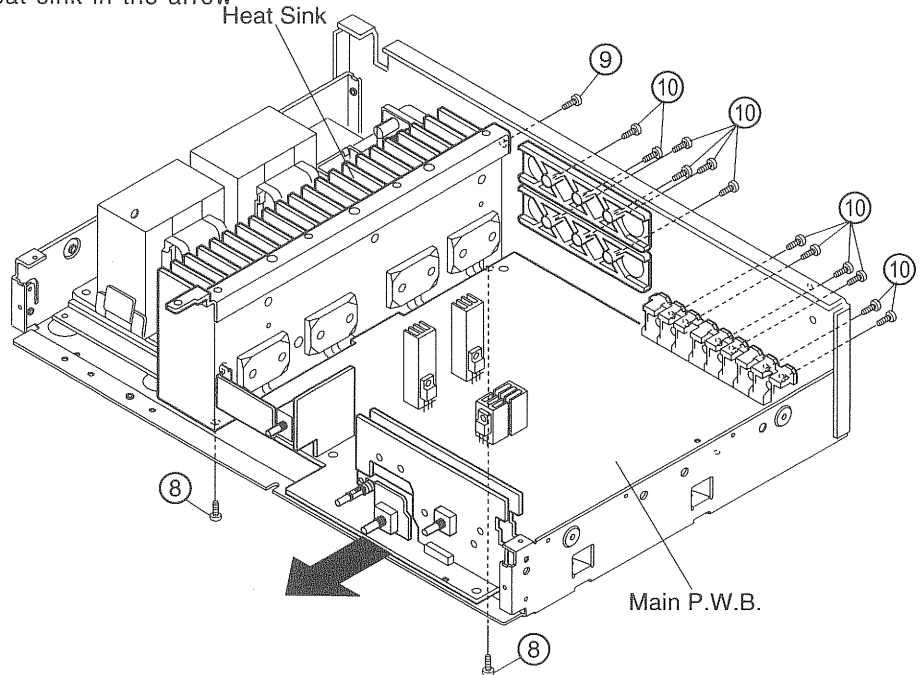

BLOCK AND LEVEL DIAGRAM

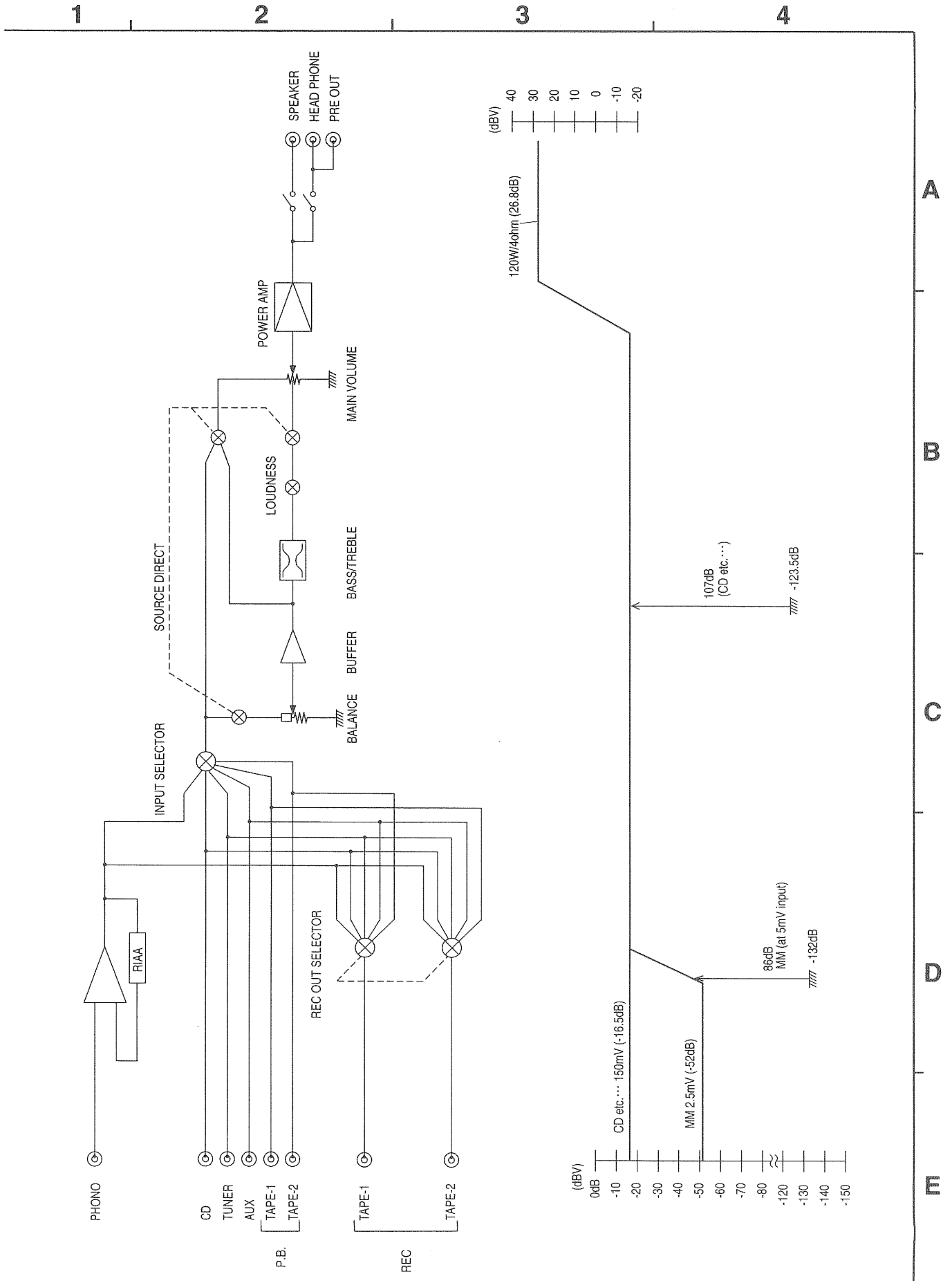

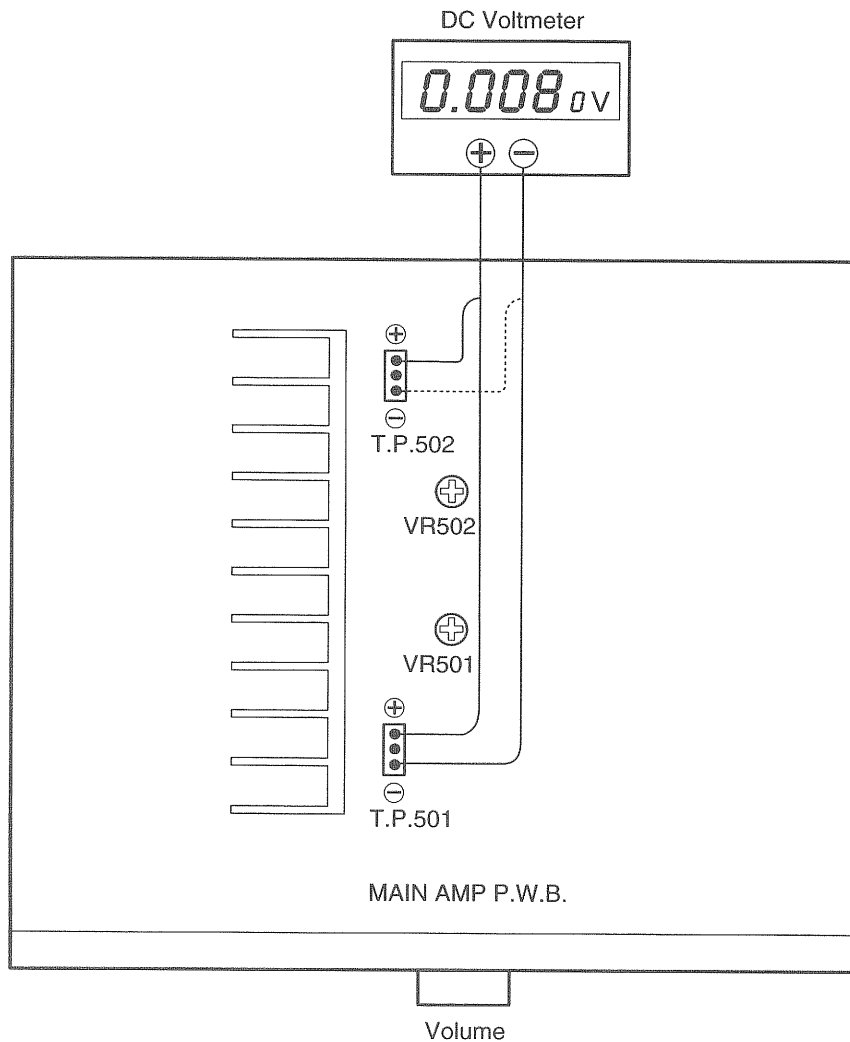

ADJUSTMENT



IDLING CURRENT

● Setup

1. Place the unit at an ordinary position avoiding direct air flow from an air-conditioner or fan. Do the adjustment at a temperature between 15 °C (59 °F) and 30 °C (86 °F).
2. Set controls as follows.

POWER switch	→	OFF ()
VOLUME control	→	fully counterclockwise ( min.)
SPEAKER terminals	→	open: do not connect the speakers, dummy load etc.

● Adjustment

1. Remove top cover. And then connect DC voltmeter to the test points TP501 and TP502 of MAIN AMP P.W.B.
2. Connect power cord to AC230V (218 ~ 242V) (Europe, Asia, Australia & Hong Kong Models) or AC120V (114 ~ 126V) (U.S.A, Canada & TAIWAN R.O.C. Models) wall outlet, and turn POWER switch "ON" ().
3. Right after power on, adjust VR501 and VR502 so that the DC voltmeter reads $10 \pm 1\text{mV}$.
4. Then after 2 minutes warmup, adjust VR501 and VR502 so that the DC voltmeter reads $10 \pm 1\text{mV}$.
5. And after 10 minutes warmup, adjust VR501 and VR502 so that the DC voltmeter reads $10 \pm 0.5\text{mV}$.

SEMICONDUCTORS

● IC's

TMP87C846N (IC901)

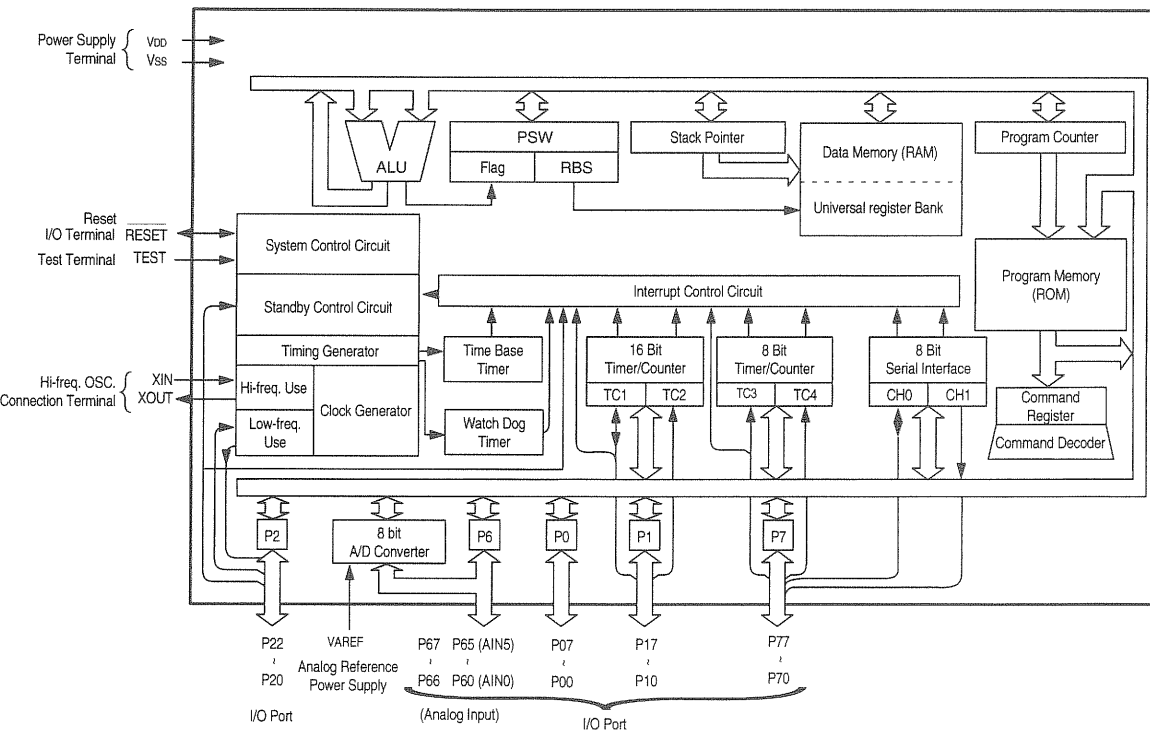
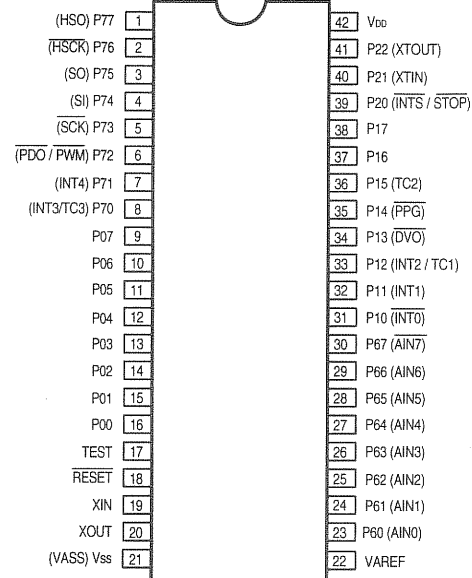
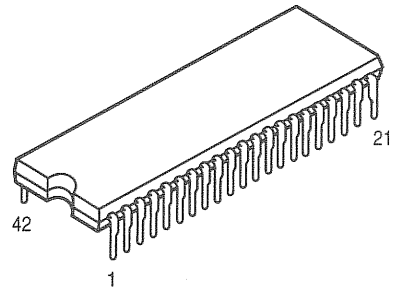

TMP87C846N Terminal Function

Pin No.	Port Name	I/O	Typ	Function	
1	P77	O	C	AC power relay drive	
2	P76	O	C		
3	P75	(SO)	O	C	Analog switch data
4	P74	(SI)	O	C	Analog switch strobe
5	P73	(SCK)	O	C	Analog switch clock
6	P72		O	C	Mute/standby LED drive
7	P71	(INT4)	O	C	Motor volume up
8	P70	(INT3)	I	C	Remote control signal input
9	P07		O	C	TAPE-2 LED drive
10	P06		O	C	TAPE-1 LED drive
11	P05		O	C	
12	P04		O	C	
13	P03		O	C	AUX LED drive
14	P02		O	C	TUNER LED drive
15	P01		O	C	CD LED drive
16	P00		O	C	PHONO LED drive
17	TEST			To V _{SS}	
18	RESET			Reset	
19	XIN			X'tal input	
20	XOUT			X'tal output	
21	V _{SS}	(V _{ASS})		GND	
22	VAREF			To V _{DD}	
23	P60	I	C		
24	P61	I	C		
25	P62	I	C	REC OUT selector switch input	
26	P63	I	C	Function switch encoder input	
27	P64	I	C		
28	P65	O	C	Muting signal output	
29	P66	O	C		
30	P67	O	C		
31	P10	(INT0)	I	C	Protector input
32	P11	(INT1)	I	C	Power off
33	P12	(INT2)	O	C	Motor volume down
34	P13		O	C	
35	P14		O	C	
36	P15		O	C	
37	P16		O	C	
38	P17		O	C	
39	P20	STOP	I	N	STOP MODE cancel
40	P21		I	N	
41	P22		I	N	
42	V _{DD}			+5V	

Note: Pin: Terminal number of μ com.
 Port: The name entered in the data sheet of μ com.
 I/O: Input or output of port.
 "I"= Input port
 "O"= Output port
 Type: Composition of port in case of output port.
 "C"= CMOS output
 "N"= NMOS output
 Function: Function and logical level of the signals to be interfaced.

TC9163AN (IC202)
TC9164AN (IC203)

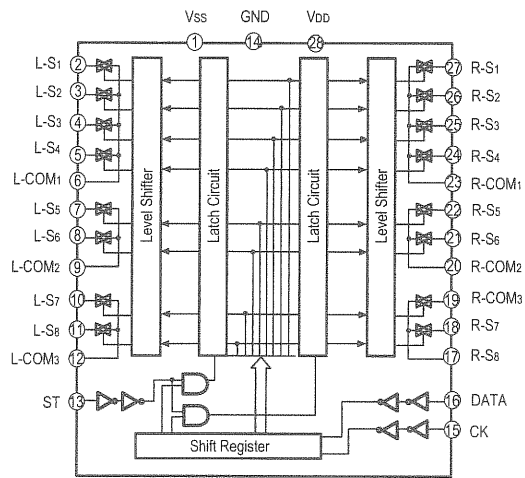
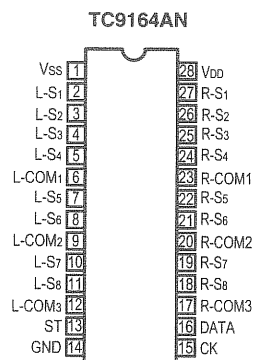
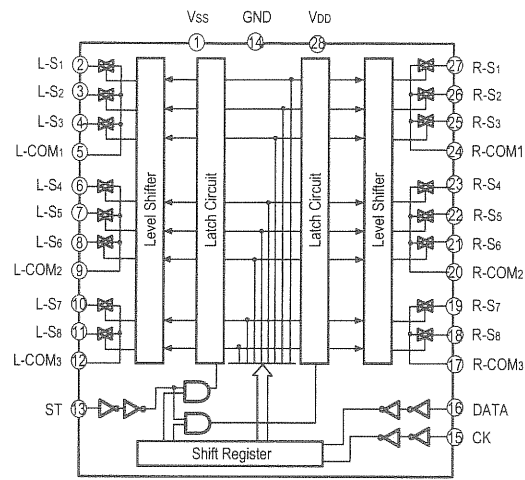
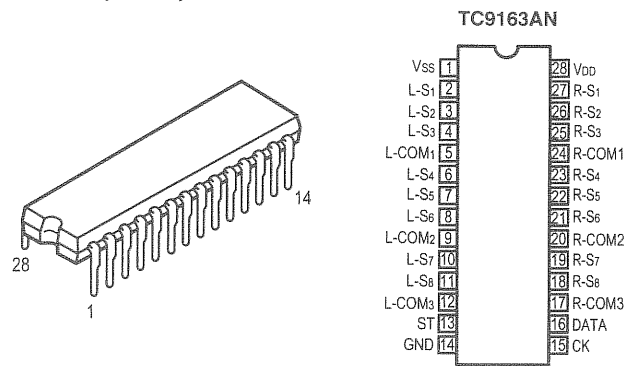

LB1639 (IC902)

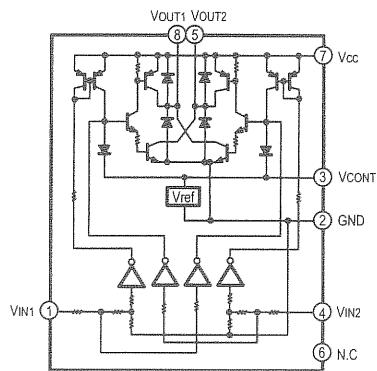
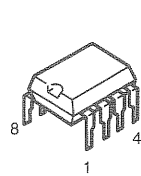

NJM2068DDC (IC401)
NJM2043DD (IC301)

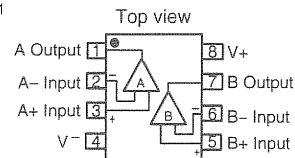
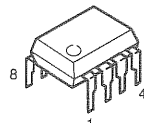

NJM7806FA(S) (IC903)
NJM7812FA(S) (IC101)

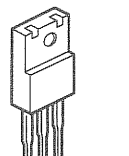

GP1U271X (Remote Control Sensor) (IC904)

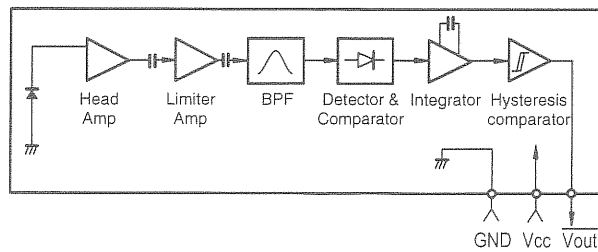
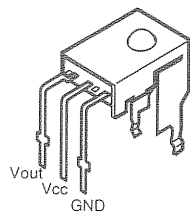

TRANSISTORS

2SA933S (S)
2SC1740 (S)

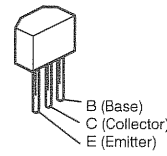

2SA988 (E/F)
2SC1841 (E/F)

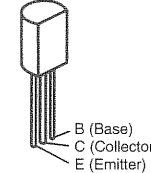

2SB1274 (R/S)
2SD1913 (R/S)

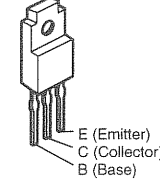

2SK184C (GR)/(BL)

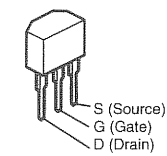

MP1715
MN1715

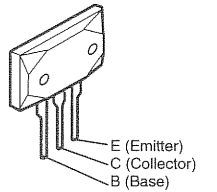

2SC4495 (O/Y)

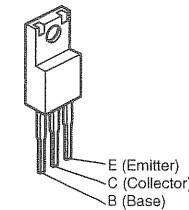

2SC2412K (S)

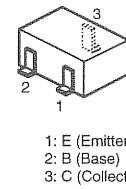

DTA114EK
DTC114EK

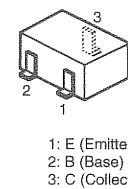

DTA114EK

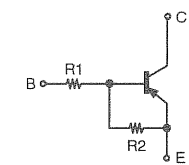

DTC114EK

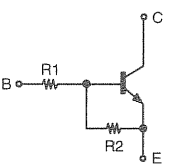

	R1	R2
DTA114EK	10 kohm	10 kohm
DTC114EK	10 kohm	10 kohm

RN1205 (2.2k-47k)

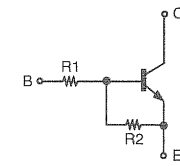
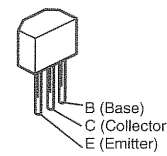

	R1	R2
RN1205	2.2 kohm	47 kohm

DIODES (including LED)

1SS270A

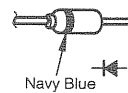

1SR35-400A

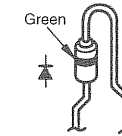

MTZJ2.7A
MTZJ3.3A
MTZJ6.2A
MTZJ7.5C
MTZJ18A

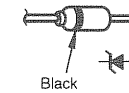

SLR-342VR (LED)
SEL-1210S

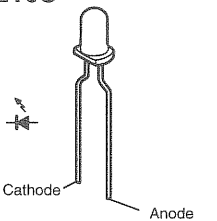

FCH20A15

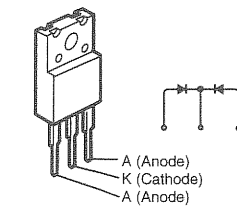

FRH20A15

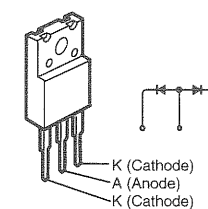

MA152WA

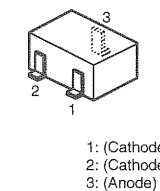

POSISTOR

PTH9M04BC222TS2F333 (TH701)

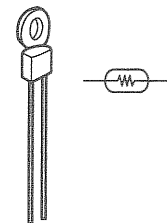

PRINTED WIRING BOARDS

1 2 3 4 5 6 7 8

1U-3156 MAIN P.W.B. UNIT ASS'Y

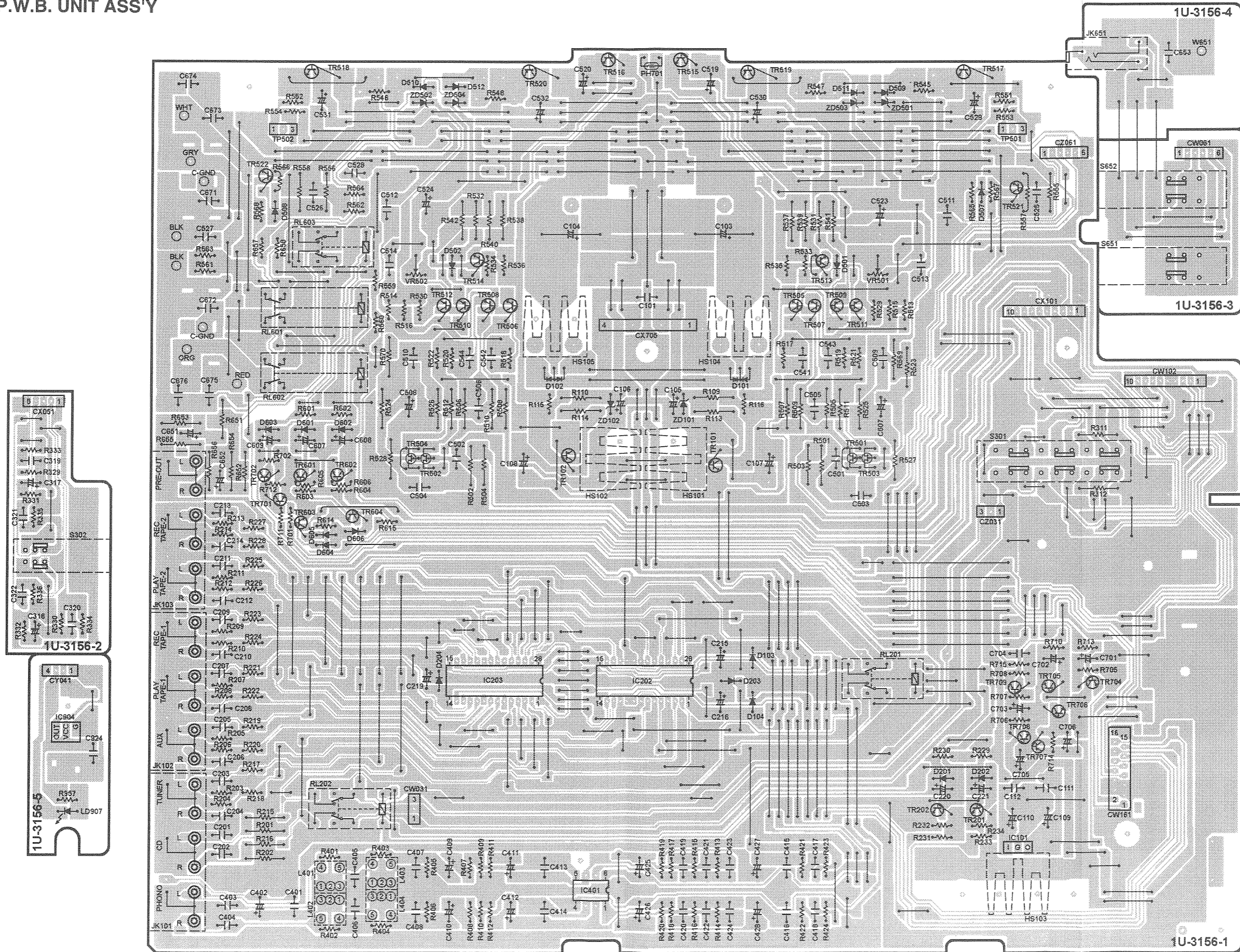

A

B

C

D

E

FOIL SIDE

1 2 3 4 5 6 7 8

1U-3248 U-COM P.W.B. UNIT ASS'Y

A

B

C

D

E

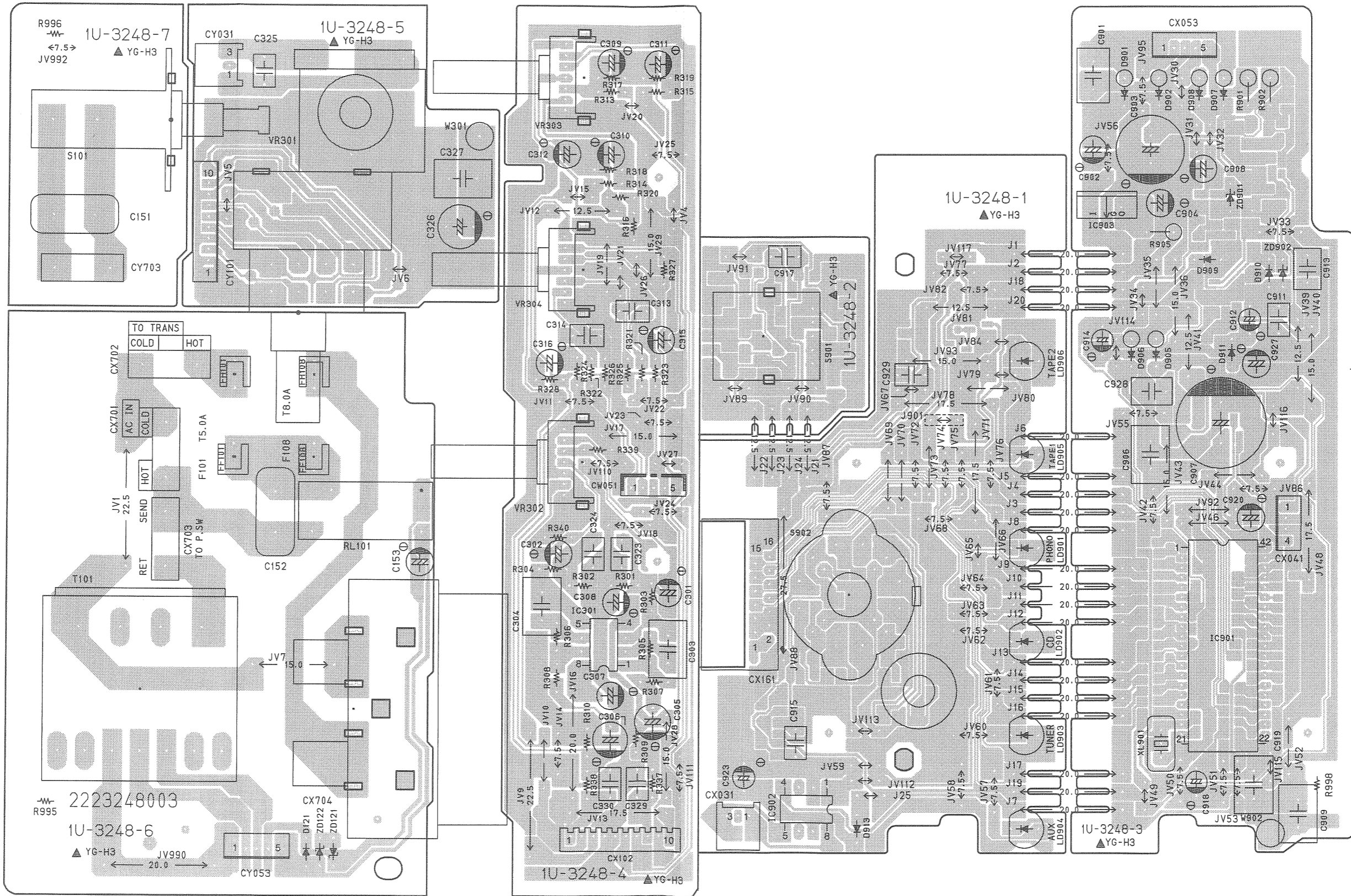

COMPLEMENT SIDE

1 2 3 4 5 6 7 8

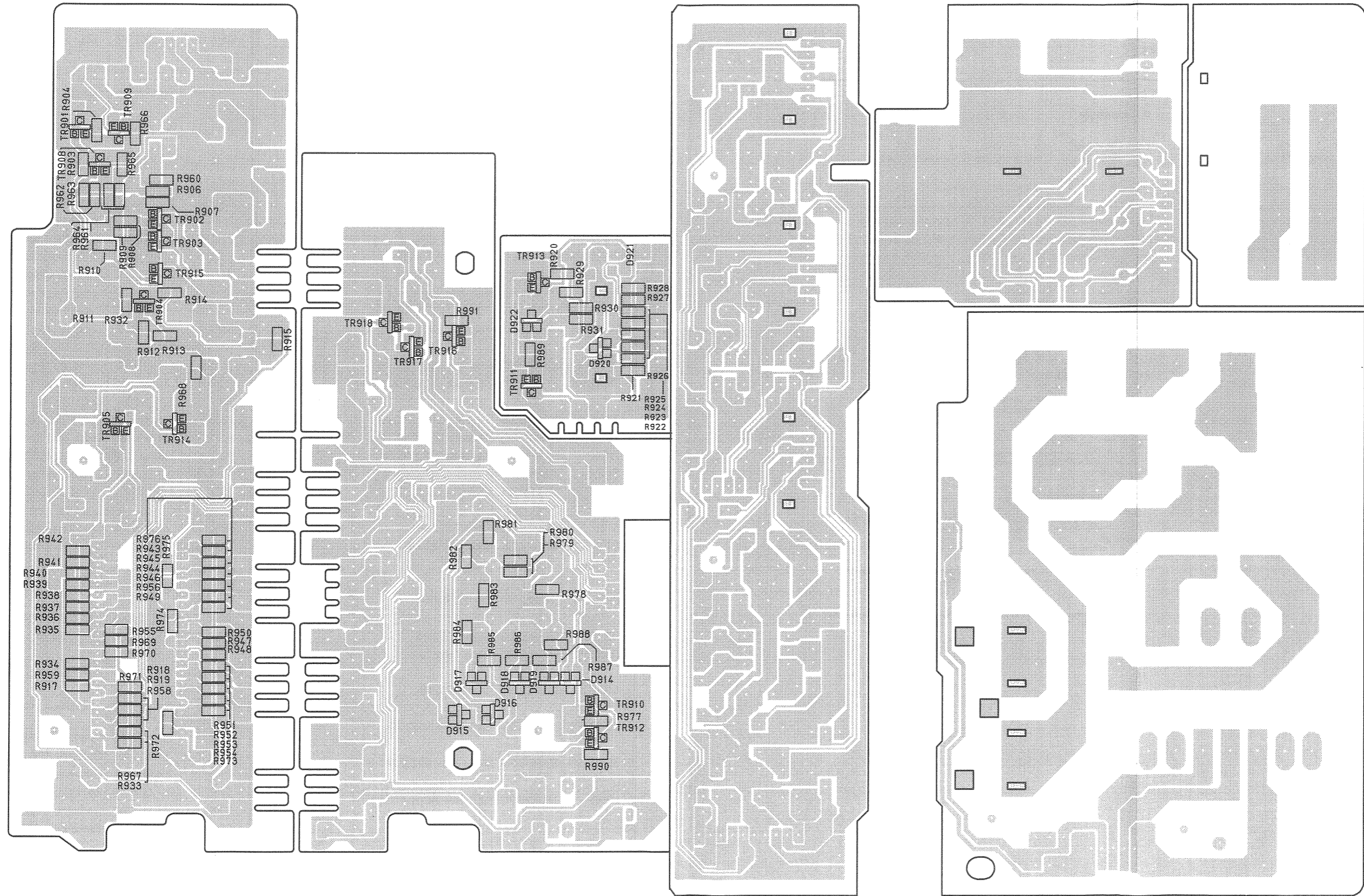

FOIL SIDE

A
B
C
D
E

NOTE FOR PARTS LIST

- Part indicated with the mark "⊕" are not always in stock and possibly to take a long period of time for supplying, or in some case supplying of part may be refused.
- When ordering of part, clearly indicate "1" and "I" (i) to avoid mis-supplying.
- Ordering part without stating its part number can not be supplied.
- Part indicated with the mark "★" is not illustrated in the exploded view.
- Not including Carbon Film ±5%, 1/4W Type in the P.W.Board parts list. (Refer to the Schematic Diagram for those parts.)

WARNING:

Parts marked with this symbol have critical characteristics.
Use ONLY replacement parts recommended by the manufacturer.

● **Resistors**

Ex.: FN 14K 2E 182 G FR
 Type Shape Power Resist- Allowable Others
 and per- ance error

RD : Carbon	2B : 1/8W	F : ±1%	P : Pulse-resistant type
RC : Composition	2E : 1/4W	G : ±2%	NL : Low noise type
RS : Metal oxide film	2H : 1/2W	J : ±5%	NB : Non-burning type
RW : Winding	3A : 1W	K : ±10%	FR : Fuse-resistor
RN : Metal film	3D : 2W	M : ±20%	F : Lead wire forming
RK : Metal mixture	3F : 3W		
	3H : 5W		

* **Resistance**

1 8 2 ⇒ 1800 ohm = 1.8 kohm
 ↑ ↑ ↑
 1-digit effective number. 2-digit effective number.

• Units: ohm

1 2 2 ⇒ 1.2 ohm
 ↑ ↑ ↑
 1-digit effective number. 2-digit effective number, decimal point indicated by R.

• Units: ohm

● **Capacitors**

Ex.: CE 04W 1H 2R2 M BP
 Type Shape Dielectric Capacity Allowable Others
 and per- strength error

CE : Aluminum foil electrolytic	OJ : 6.3V	F : ±1%	HS : High stability type
CA : Aluminum solid electrolytic	1A : 10V	G : ±2%	BP : Non-polar type
CS : Tantalum electrolytic	1C : 16V	J : ±5%	HR : Ripple-resistant type
CO : Film	1E : 25V	K : ±10%	DL : For charge and discharge
CK : Ceramic	1V : 35V	M : ±20%	HF : For assuring high frequency
CC : Ceramic	1H : 50V	Z : +80%	U : UL part
CP : Oil	2A : 100V	-20%	C : CSA part
CM : Mica	2B : 125V	P : +100%	W : UL-CSA type
CF : Metallized	2C : 160V	-0%	F : Lead wire forming
CH : Metallized	2D : 200V	C : ±0.25pF	
	2E : 250V	D : ±0.5pF	
	2H : 500V	= : Others	
	2J : 630V		

* **Capacity (electrolyte only)**

2 2 2 ⇒ 2200μF
 ↑ ↑ ↑
 Indicates number of zeros after effective number. 2-digit effective number.

• Units: μF.

2 R 2 ⇒ 2.2μF
 ↑ ↑ ↑
 1-digit effective number. 2-digit effective number, decimal point indicated by R.

• Units: μF.

* **Capacity (except electrolyte)**

2 2 2 ⇒ 2200pF=0.0022μF
 ↑ ↑ ↑ (More than 2) — Indicates number of zeros after effective number. 2-digit effective number.

• Units: μF.

2 2 1 ⇒ 220pF
 ↑ ↑ ↑ (0 or 1) — Indicates number of zeros after effective number. 2-digit effective number.

• Units: pF.

• When the dielectric strength is indicated in AC, "AC" is included after the dielectric strength value.

PARTS LIST OF P.W.B. UNIT ASS'Y 1U-3156E MAIN P.W.B. UNIT

Ref. No.	Part No.	Part Name	Remarks	Ref. No.	Part No.	Part Name	Remarks
SEMICONDUCTORS GROUP				RESISTORS GROUP			
IC101	263 0801 004	IC NJM7812FA (S)		R109,110	241 2425 967	Carbon film 22kohm 1/4W	RD14B2E223J (PSNB)
IC202	262 2487 009	IC TC9163AN		R113,114	241 2422 944	Carbon film 1kohm 1/4W	RD14B2E102J (PSNB)
IC203	262 2488 008	IC TC9164AN		R115,116	241 2387 940	Carbon film 4.7ohm 1/4W (NB)	RD14B2E4R7JNBS
IC401	263 0609 002	IC NJM2068DDC		R201,202	241 2428 948	Carbon film 330kohm 1/4W	RD14B2E334J (PSNB)
IC904	499 0290 007	Remocon sensor GP1U271X		R215,216	241 2420 988	Carbon film 220ohm 1/4W	RD14B2E221J (PSNB)
TR101	274 0136 012	Transistor 2SD1913 (R/S)		R311,312	241 2423 972	Carbon film 3.6kohm 1/4W	RD14B2E362J (PSNB)
TR102	272 0093 010	Transistor 2SB1274 (R/S)		R501,502	241 2421 961	Carbon film 470ohm 1/4W	RD14B2E471J (PSNB)
TR201,202	273 0303 910	Transistor 2SC1740S (S)		R503,504	241 2429 963	Carbon film 1Mohm 1/4W	RD14B2E105J (PSNB)
TR501~504	275 0055 015	FET 2SK184C (GR)/(BL)		R505,506	241 2420 904	Carbon film 100ohm 1/4W	RD14B2E101J (PSNB)
TR505~508	273 0235 923	Transistor 2SC1841 (E/F)		R507~510	241 2424 900	Carbon film 4.7kohm 1/4W	RD14B2E472J (PSNB)
TR509~512	271 0131 924	Transistor 2SA988 (E/F)		R511,512	241 2424 968	Carbon film 8.2kohm 1/4W	RD14B2E822J (PSNB)
TR513,514	273 0235 923	Transistor 2SC1841 (E/F)		R513~520	241 2378 962	Carbon film 330ohm 1/4W (NB)	RD14B2E331JNBS
TR521,522	273 0235 923	Transistor 2SC1841 (E/F)		R521,522	244 2064 932	Metal oxide 3.9kohm 1W (NB)	RS14B3A392JNBS (S)
TR601,602	273 0303 910	Transistor 2SC1740S (S)		R523,524	241 2429 963	Carbon film 1Mohm 1/4W	RD14B2E105J (PSNB)
TR603,604	269 0067 901	Transistor RN1205 (2.2K-47K)		R525,526	241 2425 983	Carbon film 27kohm 1/4W	RD14B2E273J (PSNB)
TR701,702	273 0303 910	Transistor 2SC1740S (S)		R527,528	241 2420 946	Carbon film 150ohm 1/4W	RD14B2E151J (PSNB)
TR704~706	273 0303 910	Transistor 2SC1740S (S)		R529,530	241 2377 921	Carbon film 82ohm 1/4W (NB)	RD14B2E820JNBS
TR707	271 0192 905	Transistor 2SA933S (S)		R531,532	241 2424 955	Carbon film 7.5kohm 1/4W	RD14B2E752J (PSNB)
TR708	273 0303 910	Transistor 2SC1740S (S)		R533~536	241 2377 992	Carbon film 160ohm 1/4W (NB)	RD14B2E161JNBS
TR709	271 0131 924	Transistor 2SA988 (E/F)		R537,538	241 2425 912	Carbon film 13kohm 1/4W	RD14B2E133J (PSNB)
D101	276 0706 008	Diode FCH20A15		R539,540	241 2424 900	Carbon film 4.7kohm 1/4W	RD14B2E472J (PSNB)
D102	276 0707 007	Diode FRH20A15		R541,542	241 2424 955	Carbon film 7.5kohm 1/4W	RD14B2E752J (PSNB)
D103,104	276 0704 903	Diode 1SR35-400A		R545~548	243 2061 000	Winding 0.1ohm 3W	RW99=3F0R1K
D201~204	276 0432 903	Diode 1SS270A		R555~558	241 2425 967	Carbon film 22kohm 1/4W	RD14B2E223J (PSNB)
D501,502	276 0432 903	Diode 1SS270A		R561~564	244 2043 937	Metal oxide 10ohm 1W (NB)	RS14B3A100JNBS (S)
D507~512	276 0432 903	Diode 1SS270A		R651,652	241 2425 909	Carbon film 12kohm 1/4W	RD14B2E123J (PSNB)
D601~606	276 0432 903	Diode 1SS270A		R653,654	241 2422 902	Carbon film 680ohm 1/4W	RD14B2E681J (PSNB)
ZD101,102	276 0645 907	Zener diode MTZJ18A		R655,656	241 2427 923	Carbon film 100kohm 1/4W	RD14B2E104J (PSNB)
ZD501~504	276 0643 925	Zener diode MTZJ2.7A		R657,658	244 2052 931	Metal oxide 390ohm 1W (NB)	RS14B3A391JNBS (S)
LD907	393 9539 908	LED SLR-342VRTF7LM		R996	241 2429 963	Carbon film 1Mohm 1/4W	RD14B2E105J (PSNB)
				R998	241 2429 963	Carbon film 1Mohm 1/4W	RD14B2E105J (PSNB)
				VR501,502	211 6075 024	Semi fixed resistor 4.7kohm	V06PB472 (CERMET)
SEMICONDUCTORS GROUP				CAPACITORS GROUP			
				C101	256 1042 903	Metallized 0.1μF/250V	CF93A2E104K
				C103,104	254 6221 008	Electrolytic 8200μF/63V	CE68W1J822M (DL)
				C105,106	254 4313 918	Electrolytic 10μF/50V	CE04W1H100M (ASF)
				C107,108	254 4313 950	Electrolytic 100μF/50V	CE04W1H101M (ASF)
				C109	254 4368 947	Electrolytic 220μF/25V	CE04W1E221M (ASF)
				C110	254 4573 949	Electrolytic 1μF/50V	CE04W1H010M (RE3)
				C215,216	254 4313 918	Electrolytic 10μF/50V	CE04W1H100M (ASF)
				C219	254 4313 921	Electrolytic 22μF/50V	CE04W1H220M (ASF)
				C317,318	254 4524 927	Electrolytic 0.33μF/50V	CE04W1HR33M (SMG/RE3)

Ref. No.	Part No.	Part Name	Remarks	Ref. No.	Part No.	Part Name	Remarks	Q'ty	
C401	255 4237 903	Polypropylene film 2700pF/100V	CQ93P2A272J (NH)	OTHER PARTS GROUP					
C407,408	253 1179 929	Ceramic 150pF/50V	CK45B1H151K	CW061	205 0343 061	6P connector base (KR-PH)		1	
C409,410	254 4254 909	Electrolytic 10μF/16V	CE04W1C100M	CW102	205 1081 005	10P FJ connector base		1	
C411,412	254 4252 943	Electrolytic 220μF/10V	CE04W1A221M	CW161	205 1056 027	16P connector socket (TKC-V)		1	
C419,420	255 1265 907	Mylar film 6800pF/50V	CQ93M1H682J (B)	CX051	205 0885 008	5P connector socket (TUC-P)		1	
C421,422	255 1265 978	Mylar film 0.022μF/50V	CQ93M1H223J (B)	CX101	205 0375 000	10P connector base (KR-PH)		1	
C423,424	255 1264 940	Mylar film 2200pF/50V	CQ93M1H222J (B)	CX705	205 0087 042	4P wrapping terminal		1	
C425,426	254 4313 963	Electrolytic 1μF/50V	CE04W1H010M (ASF)	CY041	205 0343 045	4P connector base (KR-PH)		1	
C427,428	254 4524 956	Electrolytic 2.2μF/35V	CE04W1H2R2M (SMG/RE3)	CZ061	205 0343 061	6P connector base (KR-PH)		1	
C501~504	255 4235 918	Polypropylene film 100pF/100V	CQ93P2A101J (NH)	JK101~103	204 8543 019	6P pin jack		3	
C505,506	255 1264 940	Mylar film 2200pF/50V	CQ93M1H222J (B)	JK651	204 8341 004	Headphone jack		1	
C507,508	254 4583 971	Electrolytic 47μF/50V	CE04W1H470M (ROB)	RL201,202	214 0127 003	Relay (RY-12W)		2	
C509,510	255 4232 924	Polypropylene film 39pF/100V	CQ93P2A390J (NH)	RL601,602	214 0195 006	Relay (FTR-F1)		2	
C513,514	255 4242 901	Polypropylene film 15pF/100V	CQ93P2A150J (NH)	RL603	214 0127 003	Relay (RY-12W)		1	
C523,524	254 4580 712	Electrolytic 100μF/50V	CE04W1H101M (ROB)	S301	212 1130 006	1P push switch		1	
C525,526	255 4232 937	Polypropylene film 1000pF/100V	CQ93P2A102J (NH)	S302	212 1175 003	1P push switch		1	
C527,528	256 1058 971	Metallized 0.1μF/50V	CF93A1H104J (JL)	S651	212 4690 006	2P push switch		1	
C529~532	254 4367 919	Electrolytic 4.7μF/63V	CE04W1J4R7M (ASF)	TP501,502	205 0190 036	3P NH connector base		2	
C541~544	255 1264 940	Mylar film 2200pF/50V	CQ93M1H222J (B)	W651	203 0501 027	1P SIN contact Ass'y		1	
C607,608	254 4313 921	Electrolytic 22μF/50V	CE04W1H220M (ASF)		203 0676 004	1P contact Ass'y		2	
C651,652	254 4525 913	Electrolytic 47μF/50V	CE04W1H470M (SMG/RE3)		203 0676 017	1P contact Ass'y		1	
C653	255 4232 937	Polypropylene film 1000pF/100V	CQ93P2A102J (NH)		203 0676 020	1P contact Ass'y		1	
C701	254 4256 949	Electrolytic 100μF/25V	CE04W1E101M		203 0676 033	1P contact Ass'y		1	
C702	254 4250 945	Electrolytic 330μF/6.3V	CE04W0J331M		203 0676 046	1P contact Ass'y		1	
C703	254 4524 972	Electrolytic 4.7μF/50V	CE04W1H4R7M (SMG/RE3)		417 0476 007	Radiator		3	
C704	255 1265 936	Mylar film 0.01μF/50V	CQ93M1H103J (B)		471 3304 028	Screw 3×8 CBS-B		3	
C705	254 4573 910	Electrolytic 0.22μF/50V	CE04W1HR22M (RE3)						
C706	254 4524 943	Electrolytic 1μF/50V	CE04W1H010M (SMG/RE3)						
C924	255 4235 934	Polypropylene film 0.01μF/100V	CQ93P2A103J (NH)						

1U-3248E U-COM P.W.B. UNIT

Ref. No.	Part No.	Part Name	Remarks	Ref. No.	Part No.	Part Name	Remarks
SEMICONDUCTORS GROUP							
IC301	265 0037 007	IC NJM2043DD		R927	247 0006 946	Carbon chip 390ohm 1/10W	RM73B--391J
IC901	262 2469 108	IC TMP87C846N		R928	247 0006 991	Carbon chip 620ohm 1/10W	RM73B--621J
IC902	263 0476 002	IC LB1639		R929	247 0007 945	Carbon chip 1kohm 1/10W	RM73B--102J
IC903	263 0793 002	IC NJM7806FA (S)		R930	247 0008 915	Carbon chip 2kohm 1/10W	RM73B--202J
TR901,902	273 0384 900	Transistor 2SC2412K (S)		R931	247 0009 930	Carbon chip 6.2kohm 1/10W	RM73B--622J
TR903	269 0082 902	Transistor DTC114EK		R932	247 0009 985	Carbon chip 10kohm 1/10W	RM73B--103J
TR904	273 0384 900	Transistor 2SC2412K (S)		R933	247 0009 901	Carbon chip 4.7kohm 1/10W	RM73B--472J
TR905	269 0082 902	Transistor DTC114EK		R934-939	247 0011 944	Carbon chip 47kohm 1/10W	RM73B--473J
TR908,909	273 0384 900	Transistor 2SC2412K (S)		R940	247 0007 945	Carbon chip 1kohm 1/10W	RM73B--102J
TR910-917	269 0083 901	Transistor DTA114EK		R941-943	247 0011 944	Carbon chip 47kohm 1/10W	RM73B--473J
TR918	269 0082 902	Transistor DTC114EK		R944-946	247 0007 945	Carbon chip 1kohm 1/10W	RM73B--102J
D121	276 0432 903	Diode 1SS270A		R947,948	247 0011 944	Carbon chip 47kohm 1/10W	RM73B--473J
D901,902	276 0704 903	Diode 1SR35-400A		R949-954	247 0006 988	Carbon chip 560ohm 1/10W	RM73B--561J
D905-908	276 0704 903	Diode 1SR35-400A		R955,956	247 0009 985	Carbon chip 10kohm 1/10W	RM73B--103J
D909-911	276 0432 903	Diode 1SS270A		R958,959	247 0011 944	Carbon chip 47kohm 1/10W	RM73B--473J
D913	276 0432 903	Diode 1SS270A		R961	247 0012 927	Carbon chip 100kohm 1/10W	RM73B--104J
D914-922	276 0711 909	Diode MA152WA		R962	247 0009 985	Carbon chip 10kohm 1/10W	RM73B--103J
ZD121,122	276 0637 902	Zener diode MTZJ6.2A		R963-966	247 0009 901	Carbon chip 4.7kohm 1/10W	RM73B--472J
ZD901	276 0635 904	Zener diode MTZJ7.5C		R967	247 0011 944	Carbon chip 47kohm 1/10W	RM73B--473J
ZD902	276 0634 905	Zener diode MTZJ3.3A		R968	247 0009 901	Carbon chip 4.7kohm 1/10W	RM73B--472J
LD901-906	393 9434 906	LED SEL1210S	Red	R969-971	247 0007 945	Carbon chip 1kohm 1/10W	RM73B--102J
RESISTORS GROUP							
R901,902	244 2064 974	Metal oxide 33ohm 1W (NB)	RS14B3A330JNBS (S)	R972	247 0014 967	Carbon chip 1Mohm 1/10W	RM73B--105J
R903	247 0009 901	Carbon chip 4.7kohm 1/10W	RM73B--472J	R973-977	247 0007 945	Carbon chip 1kohm 1/10W	RM73B--102J
R904	247 0011 944	Carbon chip 47kohm 1/10W	RM73B--473J	R978	247 0004 993	Carbon chip 91ohm 1/10W	RM73B--910J
R905	241 2387 940	Carbon film 4.7ohm 1/4W (NB)	RD14B2E4R7JNBS	R979	247 0005 918	Carbon chip 110ohm 1/10W	RM73B--111J
R906,907	247 0011 944	Carbon chip 47kohm 1/10W	RM73B--473J	R980	247 0005 934	Carbon chip 130ohm 1/10W	RM73B--131J
R908	247 0007 945	Carbon chip 1kohm 1/10W	RM73B--102J	R981	247 0005 950	Carbon chip 160ohm 1/10W	RM73B--161J
R909	247 0009 901	Carbon chip 4.7kohm 1/10W	RM73B--472J	R982	247 0005 989	Carbon chip 220ohm 1/10W	RM73B--221J
R910	247 0007 945	Carbon chip 1kohm 1/10W	RM73B--102J	R983	247 0006 917	Carbon chip 300ohm 1/10W	RM73B--301J
R911	247 0009 985	Carbon chip 10kohm 1/10W	RM73B--103J	R984	247 0006 946	Carbon chip 390ohm 1/10W	RM73B--391J
R912	247 0009 901	Carbon chip 4.7kohm 1/10W	RM73B--472J	R985	247 0006 991	Carbon chip 620ohm 1/10W	RM73B--621J
R913	247 0009 985	Carbon chip 10kohm 1/10W	RM73B--103J	R986	247 0007 945	Carbon chip 1kohm 1/10W	RM73B--102J
R914	247 0013 900	Carbon chip 220kohm 1/10W	RM73B--224J	R987	247 0008 915	Carbon chip 2kohm 1/10W	RM73B--202J
R915	247 0009 985	Carbon chip 10kohm 1/10W	RM73B--103J	R988	247 0009 930	Carbon chip 6.2kohm 1/10W	RM73B--622J
R917	247 0011 944	Carbon chip 47kohm 1/10W	RM73B--473J	R989-991	247 0009 901	Carbon chip 4.7kohm 1/10W	RM73B--472J
R918-920	247 0007 945	Carbon chip 1kohm 1/10W	RM73B--102J	VR301	211 0902 009	Variable resistor 30kohm	VOLUME
R921	247 0004 993	Carbon chip 91ohm 1/10W	RM73B--910J	VR302	211 0798 103	Variable resistor 100kohm	BALANCE
R922	247 0005 918	Carbon chip 110ohm 1/10W	RM73B--111J	VR303	211 0834 009	Variable resistor 30kohm	BASS
R923	247 0005 934	Carbon chip 130ohm 1/10W	RM73B--131J	VR304	211 0834 012	Variable resistor 10kohm	TREBLE
R924	247 0005 950	Carbon chip 160ohm 1/10W	RM73B--161J	CAPACITORS GROUP			
R925	247 0005 989	Carbon chip 220ohm 1/10W	RM73B--221J	C151,152	253 8022 707	Ceramic 0.01µF/250V (AC)	CK45F2EAC103M
R926	247 0006 917	Carbon chip 300ohm 1/10W	RM73B--301J	C153	254 4313 921	Electrolytic 22µF/50V	CE04W1H220M (ASF)
				C301,302	254 4524 972	Electrolytic 4.7µF/50V	CE04W1H4R7M (SMG/RE3)
				C305,306	254 4538 900	Electrolytic 10µF/16V	CE04W1C100M (SMG/RE3)
				C307,308	254 4313 963	Electrolytic 1µF/50V	CE04W1H010M (ASF)
				C309,310	254 4524 901	Electrolytic 0.1µF/50V	CE04W1H0R1M (SMG/RE3)
				C311,312	254 4524 930	Electrolytic 0.47µF/50V	CE04W1HR47M (SMG/RE3)
				C313,314	255 1265 994	Mylar film 0.033µF/50V	CQ93M1H333J (B)
				C315,316	254 4524 914	Electrolytic 0.22µF/50V	CE04W1HR22M (SMG/RE3)

Ref. No.	Part No.	Part Name	Remarks	Ref. No.	Part No.	Part Name	Remarks	Q'ty
C323,324	253 4538 949	Ceramic 100pF/50V	CC45SL1H101J	△ S101	212 1176 002	Power switch (TV-5)		1
C325	255 1265 936	Mylar film 0.01μF/50V	CQ93M1H103J (B)	S901	212 0405 004	Rotary switch (6-1)		1
C327	255 4235 976	Polypropylene film 0.015μF/100V	CQ93P2A153J (NH)	S902	212 0407 002	Rotary switch (SRRM-12)		1
C329,330	255 1264 966	Mylar film 3300pF/50V	CQ93M1H332J (B)	△ T101	233 6322 007	Power trans. mini (E2)		1
C901	256 1058 971	Metallized 0.1μF/50V	CF93A1H104J (JL)	W301	203 0501 027	1P SIN contact Ass'y		1
C902	254 4313 921	Electrolytic 22μF/50V	CE04W1H220M (ASF)	XL901	399 0107 900	Ceramic resonator CST4.19MGW		1
C903	254 4576 713	Electrolytic 1000μF/35V	CE04W1V102M (RE3)		415 0299 000	Condenser cover	for C151,152	2
C904	254 4573 949	Electrolytic 1μF/50V	CE04W1H010M (RE3)		513 2784 053	Fuse label	for F101,108	2
C907	254 4578 724	Electrolytic 3300μF/16V	CE04W1C332M (RE3)					
C908	254 4524 914	Electrolytic 0.22μF/50V	CE04W1HR22M (SMG/RE3)					
C911	255 1265 936	Mylar film 0.01μF/50V	CQ93M1H103J (B)					
C912	254 4524 956	Electrolytic 2.2μF/35V	CE04W1H2R2M (SMG/RE3)					
C913	256 1058 971	Metallized 0.1μF/50V	CF93A1H104J (JL)					
C914	254 4524 914	Electrolytic 0.22μF/50V	CE04W1HR22M (SMG/RE3)					
C915	255 1265 936	Mylar film 0.01μF/50V	CQ93M1H103J (B)					
C917	255 1265 936	Mylar film 0.01μF/50V	CQ93M1H103J (B)					
C918	254 4573 981	Electrolytic 10μF/50V	CE04W1H100M (RE3)					
C920	254 4573 981	Electrolytic 10μF/50V	CE04W1H100M (RE3)					
C923	254 4305 968	Electrolytic 1μF/50V	CE04W1H010M (SRE)					
C928	256 1058 971	Metallized 0.1μF/50V	CF93A1H104J (JL)					
C929	255 1265 936	Mylar film 0.01μF/50V	CQ93M1H103J (B)					
OTHER PARTS GROUP				Q'ty				
CW051	205 0884 009	5P connector base (TUC-P)						1
CX031	205 0355 033	3P KR connector base (L)						1
CX041	205 0343 045	4P connector base (KR-PH)						1
CX053	205 0343 058	5P connector base (KR-PH)						1
CX102	205 1000 002	10P FJ connector plug						1
CX161	205 1055 028	16P connector base (TKC-V)						1
CX701-703	205 0606 025	2P wrapping terminal						3
△ CX704	203 3975 003	AC outlet (E2)						1
CY031	205 0355 033	3P KR connector base (L)						1
CY053	205 0343 058	5P connector base (KR-PH)						1
CY101	205 0375 000	10P connector base (KR-PH)						1
CY703	205 0442 001	2P wrapping terminal						1
EP001	412 4625 008	Earth plate	for VR301					1
△ F101	206 1075 043	Fuse 2.5A						1
△ F108	206 1075 043	Fuse 2.5A						1
FF101	202 0040 909	Fuse clip						1
FF108	202 0040 909	Fuse clip						1
FH101	202 0040 909	Fuse clip						1
FH108	202 0040 909	Fuse clip						1
RL101	214 0202 009	Relay (TV-8)						1

PARTS LIST OF EXPLODED VIEW

Ref. No.	Part No.	Part Name	Remarks	Q'ty	Ref. No.	Part No.	Part Name	Remarks	Q'ty
1	1U-3156E	Main P.W.B. unit Ass'y		1	35	112 9123 223	Knob Ass'y (M)	Gold model	1
1-1		Main unit			36	112 0865 001	Knob (F) Ass'y	Black model	1
1-2		Loud. unit			36	112 0865 014	Knob (F) Ass'y	Gold model	1
1-3		SP. SW. unit			37	112 0762 007	Knob (MARU)	Black model	4
1-4		H/P unit			37	112 0762 023	Knob (MARU)	Gold model	4
1-5		LED UNIT			38	449 0050 064	Card spacer		1
2	1U-3248E	U-COM P.W.B. unit Ass'y		1	★ 39	445 8004 007	Wire clammer		11
2-1		F. SW. unit			40	102 0636 000	Top cover	Black model	1
2-2		REC. SEL. SW. unit			40	102 0636 013	Top cover	Gold model	1
2-3		U-COM. unit			41	209 0325 007	Short pin		2
2-4		Tone unit			△ 42	203 3975 003	AC outlet (E2)	CX704	1
2-5		Main volume unit			43	414 0853 003	Shield plate		1
2-6		AC unit			44	461 0677 007	Rubber sheet		2
2-7		P. SW. unit			45	461 9036 018	Spacer		2
3	411 1267 738	Main chassis		1	46	441 1882 017	Trans. bracket		1
4	104 0282 007	Foot Ass'y		4	47	205 0989 001	4P terminal		2
5	412 2762 002	P.W.B. holder	for AC unit	1	48	441 1936 002	Plate (RD)		1
6	105 1286 241	Back panel		1	49	415 0809 005	Washer		2
7	205 0071 016	Terminal Ass'y		1	50	415 0810 010	Poron sheet (PT)		2
8	477 0018 014	Washer (P-87)		3	51	441 1941 000	Plate (M)		1
9	445 0056 008	Cord bush		1	△ 52	206 1075 043	Fuse 2.5A	F101,108	2
△ 10	206 2063 009	AC cord with plug		1	SCREWS & NUTS				
11	415 0390 019	UL tube (8.3)	for AC cord, L=120	1	101	473 7002 018	Screw 3x8 CBTS (S)-Z		10
12	417 0605 001	Power radiator		1	102	473 7005 002	Screw 3x10 CBTS (S)-Z		4
13	412 3225 205	P.W.B. bracket (A)		1	103	473 7015 018	Screw 3x8 CBTS (S)-B		9
14	279 0034 067	Posistor PTH9M04BB22TS2F333	TH701	1	104	473 7026 007	Screw 4x6 CBTS (S)-B		16
★ 15	415 0309 055	P.V.C. tube (L=07)	for Posistor, L=7	2	105	473 7501 030	Screw 3x20 CBTS (P)-Z		1
16	415 9044 007	Insulating sheet		4	106	473 7508 017	Screw 3x10 CBTS (P)-B		9
17	272 0154 001	Transistor MP1715	TR519,520	2	107	477 0153 018	Screw 3x16 CPTS (B) SW W		8
18	274 0192 001	Transistor MN1715	TR517,518	2	108	477 0064 107	Fixing screw		14
19	273 0450 009	Transistor 2SC4495 (O/Y)	TR515,516	2	109	477 0263 005	3P. swelling screw	Black model	4
20	449 0050 019	Card spacer		1	109	477 0263 018	3P. swelling screw	Gold model	4
21	412 4632 004	Radiator bracket		1	110	473 7500 015	Screw 3x8 CBTS (P)-Z		4
22	146 2211 009	Inner panel	Black model	1	111	473 8034 030	Screw 3x10 CBTS (B)-Z		9
22	146 2211 012	Inner panel	Gold model	1	112	471 3803 008	Screw 4x60 CBS		2
23	412 2404 027	P.W.B. holder (WLS-10)		2	113	473 8007 038	Cup screw 3x14 (S)		1
24	113 1356 004	Push knob (MARU)	Black model	4					
24	113 1356 062	Push knob (MARU)	Gold model	4					
25	144 2730 005	Front panel Ass'y	Black model	1					
25	144 2730 018	Front panel Ass'y	Gold model	1					
★ 26	204 2552 019	10P KR-KR ribbon 80	for CX,CY101	1					
★ 26-1	001 0135 091	Vinyl wire	Black, L=120	2					
★ 27	204 0378 088	6P KR-KR ribbon 225	for CZ,CW061	1					
★ 28	203 6386 055	4P KR-KR ribbon 400	for CX,CY041	1					
★ 29	203 8342 097	5P KR-KR ribbon 500	for CX,CY053	1					
★ 29-1	203 4872 011	3P KR-KR ribbon 300	for CX,CY031	1					
★ 30	415 0295 004	Insulating tube	12.7 Tube, L=250	1					
△ ★ 31	233 6338 004	Power trans. (E2)		2					
★ 32	001 0148 075	Vinyl wire	Orange, L=370	1					
★ 33	001 0148 088	Vinyl wire	Red, L=370	1					
34	113 9213 000	P. knob (P) Ass'y	Black model	1					
34	113 9213 039	P. knob (P) Ass'y	Gold model	1					
35	112 9123 236	Knob Ass'y (M)	Black model	1					

WIRING DIAGRAM

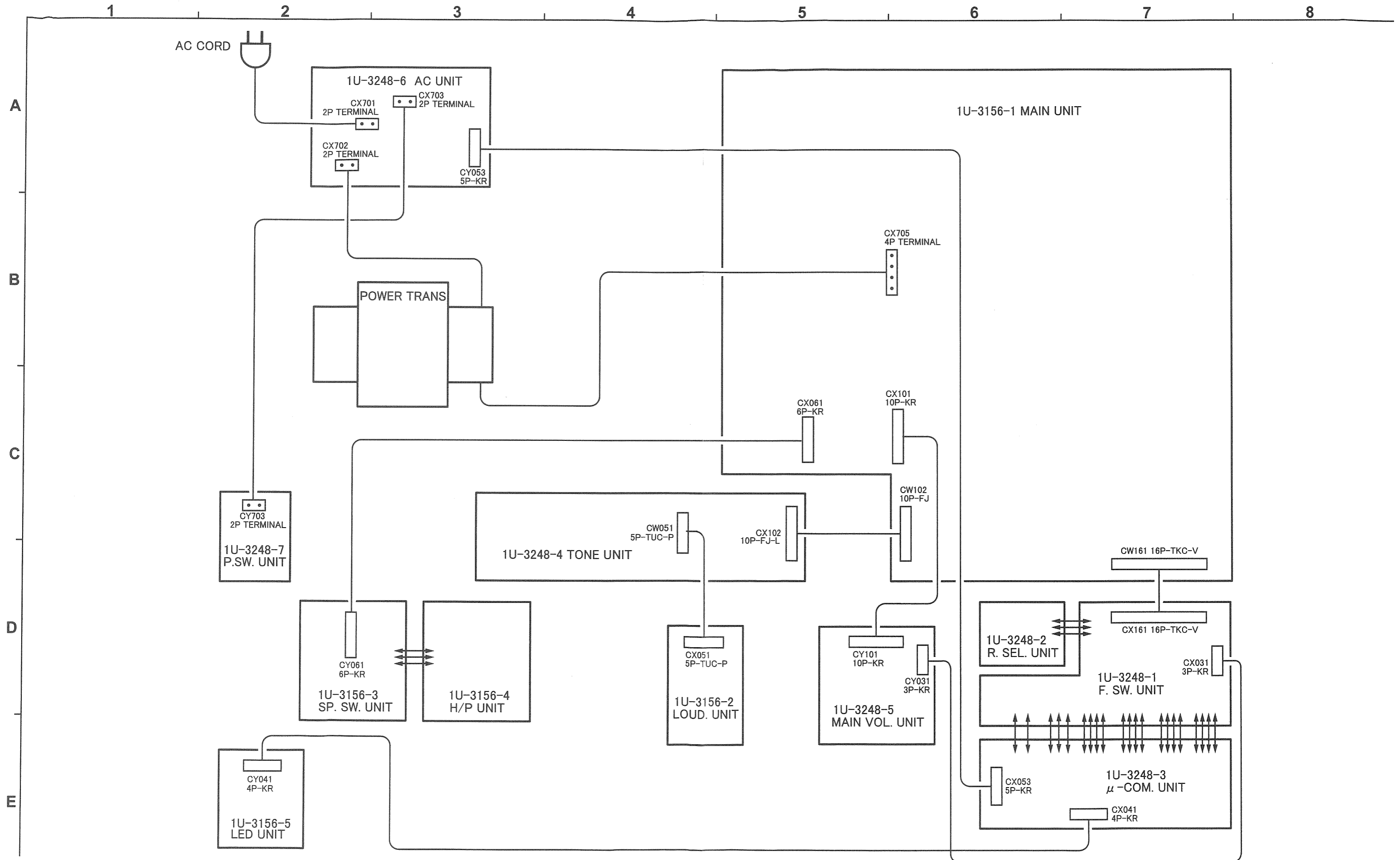

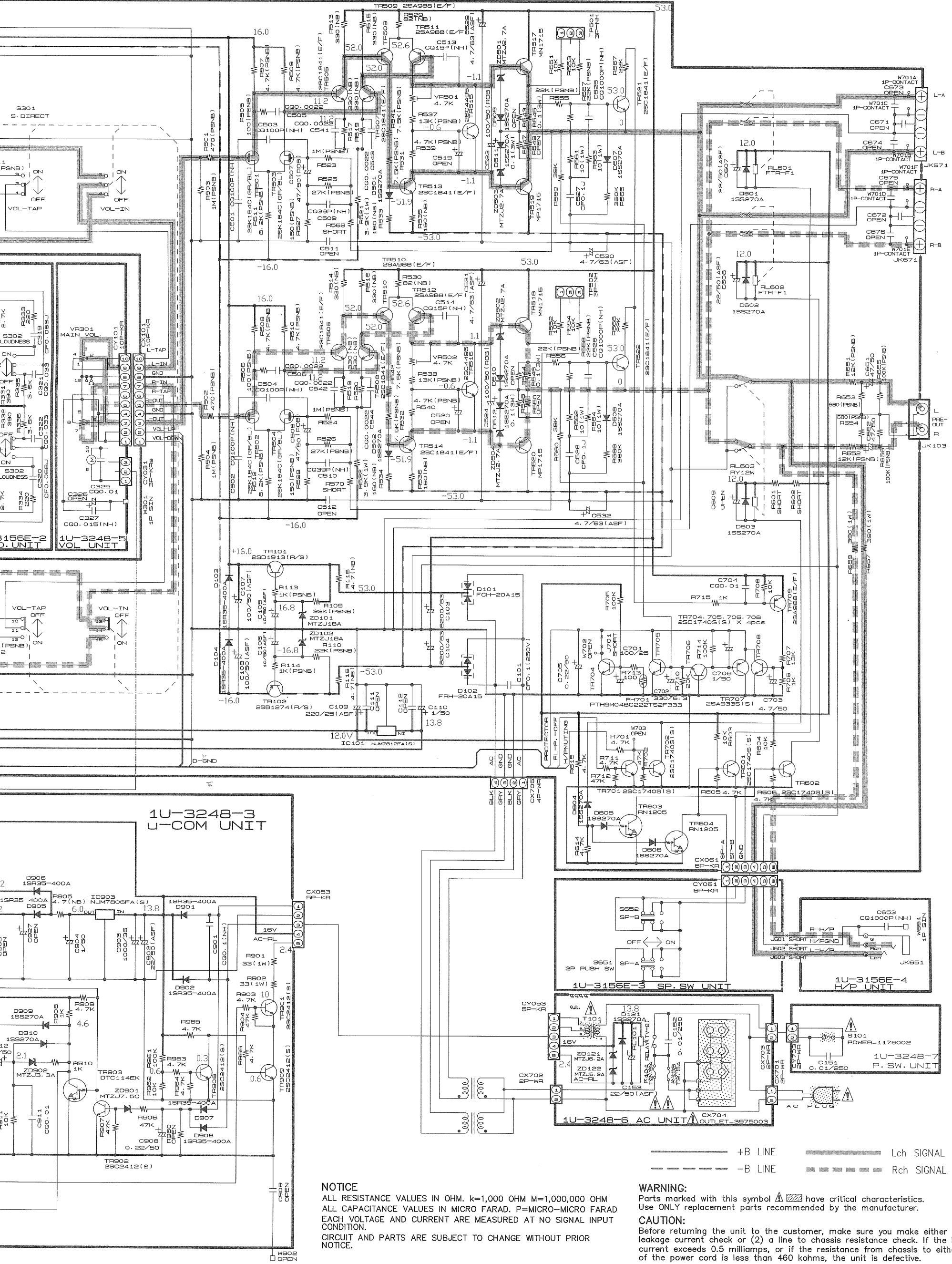

A
B
C
D
E
F
G
H

NOTICE
 ALL RESISTANCE VALUES IN OHM. k=1,000 OHM M=1,000,000 OHM
 ALL CAPACITANCE VALUES IN MICRO FARAD. P=MICRO-MICRO FARAD
 EACH VOLTAGE AND CURRENT ARE MEASURED AT NO SIGNAL INPUT
 CONDITION.
 CIRCUIT AND PARTS ARE SUBJECT TO CHANGE WITHOUT PRIOR
 NOTICE.

WARNING:
 Parts marked with this symbol have critical characteristics.
 Use ONLY replacement parts recommended by the manufacturer.

CAUTION:
 Before returning the unit to the customer, make sure you make either (1) a
 leakage current check or (2) a line to chassis resistance check. If the leakage
 current exceeds 0.5 milliamps, or if the resistance from chassis to either side
 of the power cord is less than 460 kohms, the unit is defective.

WARNING:
 DO NOT return the unit to the customer until the problem is located and
 corrected.

SCHEMATIC DIAGRAM
 1U-3156E MAIN P.W.B. UNIT
 1U-3248E U-COM P.W.B. UNIT

PACKING VIEW

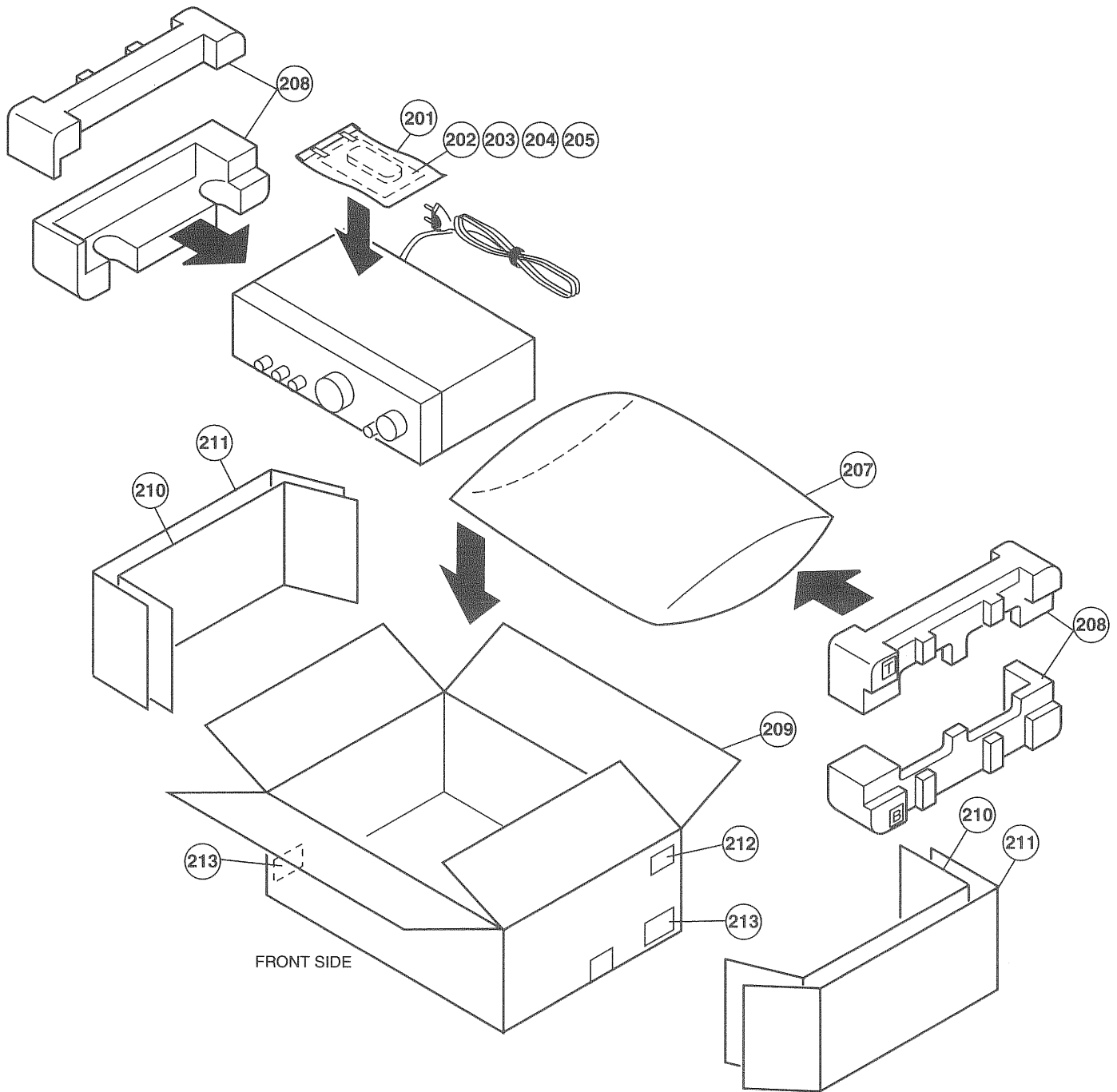

PARTS LIST OF PACKING & ACCESSORIES

Ref. No.	Part No.	Part Name	Remarks	Q'ty	Ref. No.	Part No.	Part Name	Remarks	Q'ty
201	505 8006 019	Envelope		1	210	502 0936 010	Spacer		2
202	511 3667 005	Instruction manual		1	211	502 0936 036	Spacer		2
203	515 0867 101	S.S. list (EX)		1	212	517 1417 022	E2 POS label	Black model	1
204	—	Battery UM-3		1	212	517 1417 035	E2 POS label	Gold model	1
205	399 0497 005	Remote controller RC-843		1	213	—	Control card		1
★ 206	513 1581 008	Serial no. sheet		1	★ 214	513 9111 001	Color label (Gold)	Gold model only	2
207	505 8092 007	Laminate envelope		1	★ 215	513 3501 002	Carton label (A)		1
208	503 1296 008	Cushion		2	★ 216	513 3502 001	Carton label (B)		1
209	501 2047 069	Carton case		1					

DENON

NIPPON COLUMBIA CO., LTD.

14-14, AKASAKA 4-CHOME, MINATO-KU, TOKYO 107-8011 JAPAN
Telephone: 03 (3584) 8111