

DENON

Hi-Fi Stereo Pre-main Amplifier

SERVICE MANUAL MODEL PMA-250

STEREO PRE-MAIN AMPLIFIER

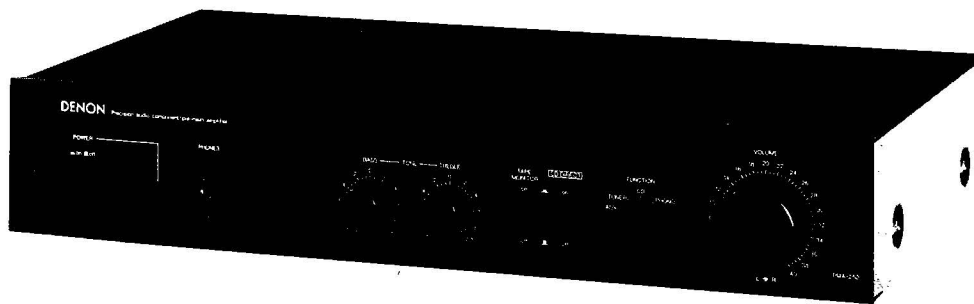

TABLE OF CONTENTS

SPECIFICATIONS	2
BLOCK DIAGRAM	2
CONTROLS AND DESCRIPTIONS	3
CONNECTIONS	3
METHOD OF ADJUSTMENTS	4
REMOVAL EACH SECTION	5
SEMICONDUCTORS	5
PRINTED WIRING BOARD PATTERNS AND PARTS LIST	
ETC0862 POWER & CONTROL UNIT (for E2)	6,10
ETC0859 POWER & CONTROL UNIT (for EK)	7,10
ETC0864 POWER & CONTROL UNIT (for E1/EA)	8,11
ETC0865 POWER & CONTROL UNIT (for EU/EC)	9,11
WIRING DIAGRAM	12
SCHEMATIC DIAGRAM	13
EXPLODED VIEW OF CHASSIS AND CABINET & PARTS LIST	14

NIPPON COLUMBIA CO., LTD.

SPECIFICATIONS

POWER AMPLIFIER SECTION

Rated Output Power: Both channel driven
(TUNER → SP OUT)
4 ohm 1 kHz DIN T.H.D. 1%:
40 W + 40 W
8 ohm 20 Hz – 20 kHz: 25 W + 25 W

Total Harmonic Distortion: 0.05% (20 Hz – 20 kHz at –3 dB rated output 8 ohm Load)

Intermodulation Distortion: Below 7 kHz/60 Hz: 1/4 0.03%
(at amplitude output equivalent to rated output)

Power Band Width: 10 Hz – 40 kHz (IHF T.H.D. 0.1%)

Frequency Response: 5 Hz – 150 kHz $\begin{matrix} +0 \\ -3 \end{matrix}$ dB
(at 1 W output)

Output Terminals: Speaker: Load 4 – 16 ohm (IEC)
EK, E2
Load 6 – 16 ohm
E1, EU, EC, EA

Headphone: Stereo headphone

PRE AMPLIFIER SECTION

Pre Amplifier Output: Maximum Output: 10 V
(at 47 k ohm Load)
Rated Output: 150 mV

Input Sensitivity/ Input Impedance: PHONO MM: 2.5 mV 47 k ohm
CD
TUNER, AUX 150 mV 47 k ohm
CD DIRECT

RIAA Deviation: PHONO MM: within ± 0.5 dB
(20 Hz – 20 kHz)

GENERAL CHARACTERISTICS

SN Ratio (IHFA Weight): PHONO MM: 70 dB (input terminals short-circuited for 2.5 mV input)
CD DIRECT, CD, TUNER, AUX: 96 dB (input terminals short-circuited)

Tone Control Adjustable

Range: BASS 100 Hz ± 10 dB
TREBLE 10 kHz ± 10 dB

AC OUTLET:

(For U.S.A., Canada and Asia) SWITCHED x 2 [100 W (Total)]
UNSWITCHED x 1 (250 W)

POWER SOURCE:

Germany and France AC 220 V, 50 Hz;
U.K. and Australia AC 240 V, 50 Hz;
U.S.A. and Canada AC 120V, 60 Hz;
Asia AC 110/120/220/240 V, 50/60 Hz (multiple)

POWER CONSUMPTION:

80 W (IEC) (Multiple)

DIMENSIONS:

434 mm (W) x 85 mm (H) x 257 mm (D)
(17-3/32" x 3-11/32" x 10-1/8")
(including rubber feet, control knobs, and terminals)

WEIGHT:

4.9 kg (10 lbs 13 oz)

Design and specifications are subject to change without prior notice.

NOTE: The following codes correspond to the appropriate models.
E2 for Europe, EK for U.K., E1 for Asia, EU for U.S.A.,
EC for Canada and EA for Australia.
This Service Manual is prepared based on E2 and black version.

BLOCK DIAGRAM

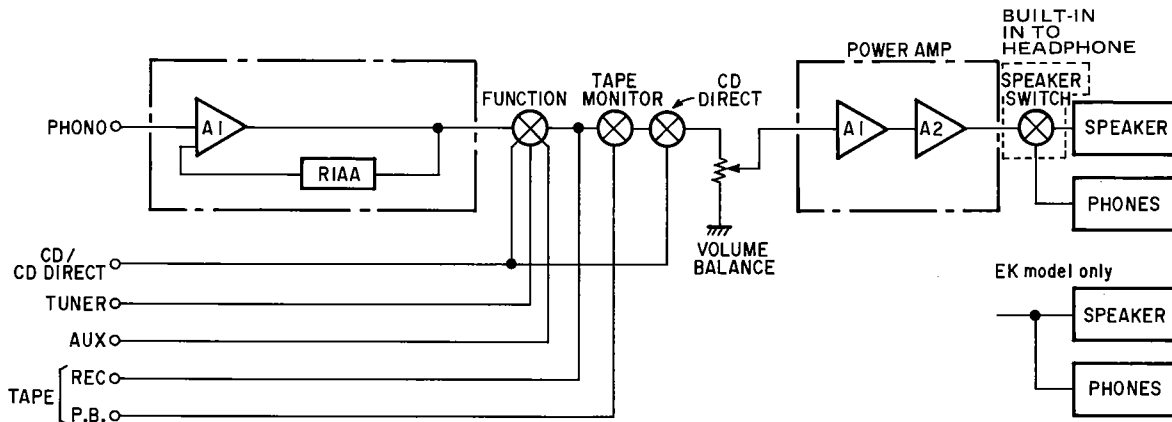

Fig. 1

CONTROLS AND DESCRIPTIONS

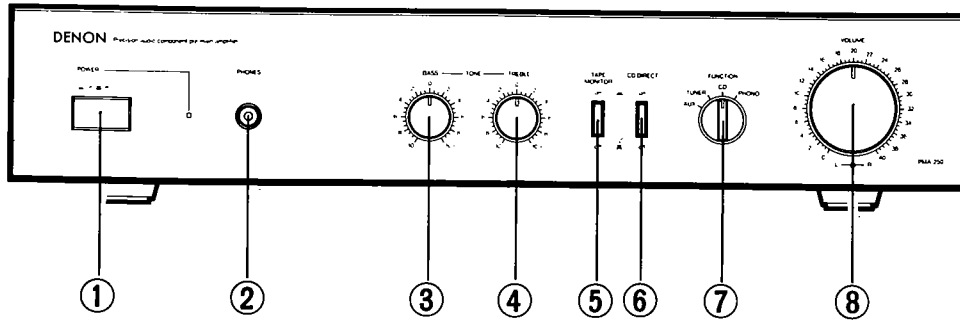
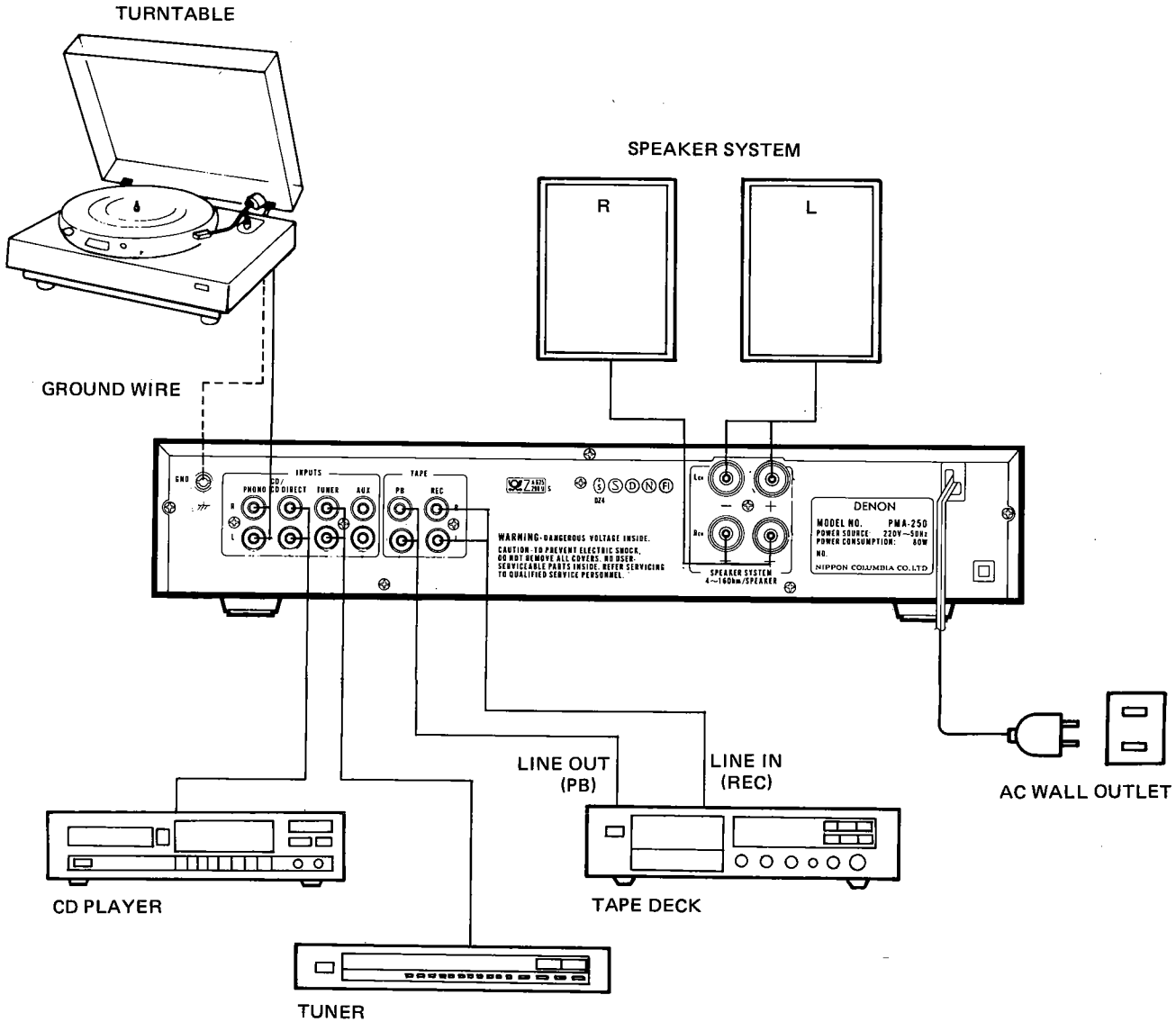

Fig. 2

- ① POWER (Power On-Off Switch)
- ② PHONES (Headphone Jack)
- ③ PASS (Bass Control)
- ④ TREBLE (Treble Control)
- ⑤ TAPE MONITOR (Tape Monitor Switch)
- ⑥ CD DIRECT (CD Direct Switch)
- ⑦ FUNCTION (Input Selector Switch)
● CD, ● Phono, ● Tuner, ● Aux
- ⑧ VOLUME (Volume Control)

CONNECTIONS



METHOD OF ADJUSTMENTS

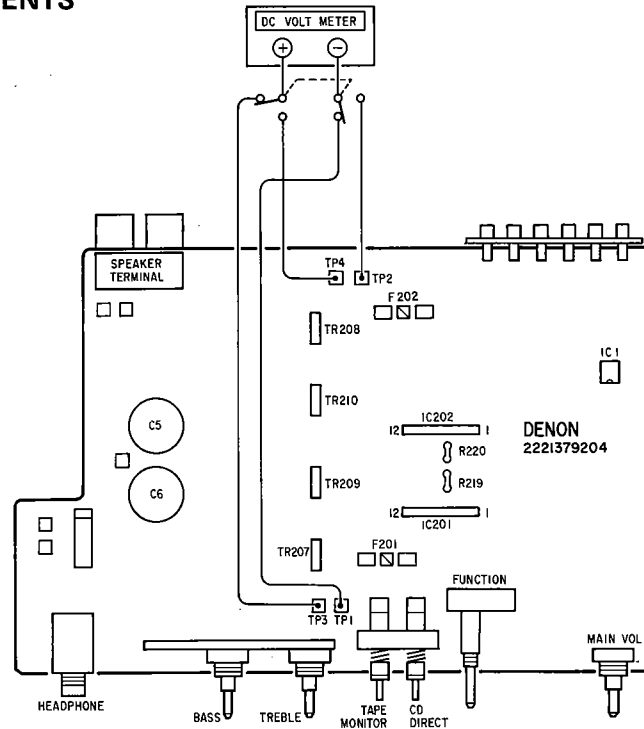

Fig. 4

IDLE CURRENT ADJUSTMENT (Fig. 4)

1. Keep the unit away from direct wind blown by an air-conditioner and an electric fan, and keep the unit under normal conditions. Adjust the range of ambient temperature to 15 – 30°C.
2. Set the following switches as follows:
 - POWER (power switch) to off
 - VOLUME (VOLUME CONTROL) to 0 (⤴)
 - SPEAKERS (speaker terminal) to no load (speakers disconnected)
3. Remove the top cover and connect a DC digital voltmeter to the test points of ETC0863* (Power and Control units) (between the positive terminal TP3 ⊕ and the negative terminal TP1 ⊖, and between the positive TP4 ⊕ and the negative terminal TP2 ⊖).
4. (1) Connect the power source cord to an AC outlet and turn on the power switch; read the measured value after 3 minutes or when the measured value is within a tolerance 6 mV ~ 90 mV (DC), adjust the idling current manually as follows.
 (2) When the voltmeter reads 6 mV (DC) or less under the condition of item (1), disconnect the 47 ohm from resistors R220 and R219.

*

Version	Unit No.	Version	Unit No.
E2	ETC0863	EU	ETC0865
EK	ETC0859	EC	ETC0865
E1	ETC0864	EA	ETC0864

- AC OUTLETS . . . For U.S.A., Canada and Asia models.
AC outlets are used for connecting amplifier component units, such as tuner, turntable, tape deck, etc.
- SWITCHED (Capacity: 100 W):
This outlet is turned on/off when main power switch is turned on/off.
- UNSWITCHED (Total capacity: 250 W):
These outlets are always ON whether power switch is on or off.
- LINE VOLTAGE (Voltage select switch) . . . For Asia model only.
 - * The desired voltage may be set with the VOLTAGE SELECTOR KNOB on the back panel using a screw driver.
 - * Do not twist the VOLTAGE SELECTOR KNOB with excessive force. It may be damaged.
 - * If the voltage select switch does not turn smoothly, see a qualified serviceman.

REMOVE OF EACH SECTION

1. How to remove the top cover (Fig. 5)

- 1) Remove the five screws holding the top cover in place.
- 2) Pull out the sides of the cover to free it, then lift off the cover.

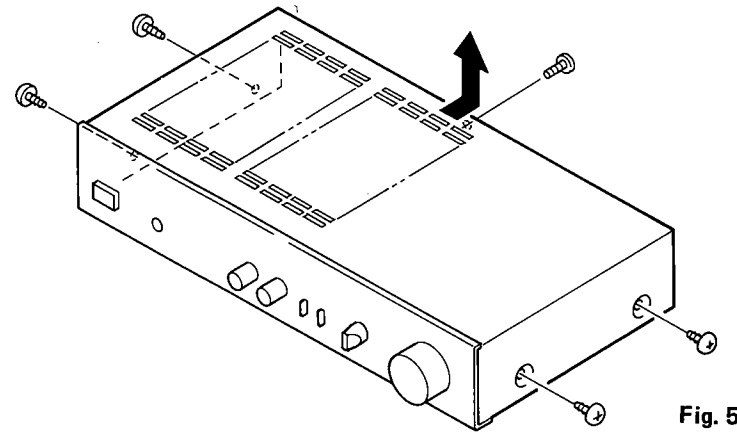

Fig. 5

2. How to remove the rear panel (Fig. 6)

- 1) Remove the nine screws holding the rear panel in place.
- 2) Pull the rear panel toward you and remove it.

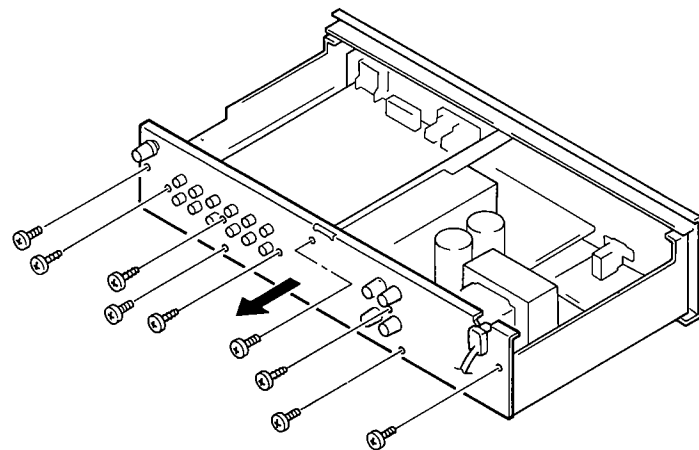

Fig. 6

3. How to remove the front panel (Fig. 7)

- 1) Pull off the four knobs.
- 2) Remove the nine screws holding the front panel in place.
- 3) Pull the front panel toward you and remove it.

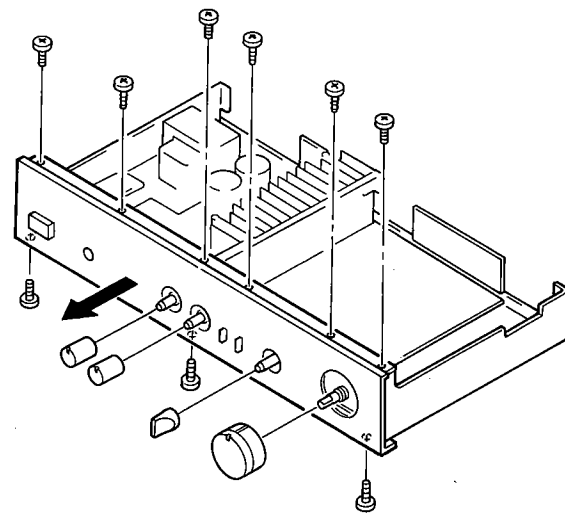

Fig. 7

4. How to remove the P.W.B. Unit (Fig. 8)

- 1) Remove the three screws holding the Main P.W.B. Unit in place.
- 2) Remove the two screws holding the Power SW P.W.B. in place.

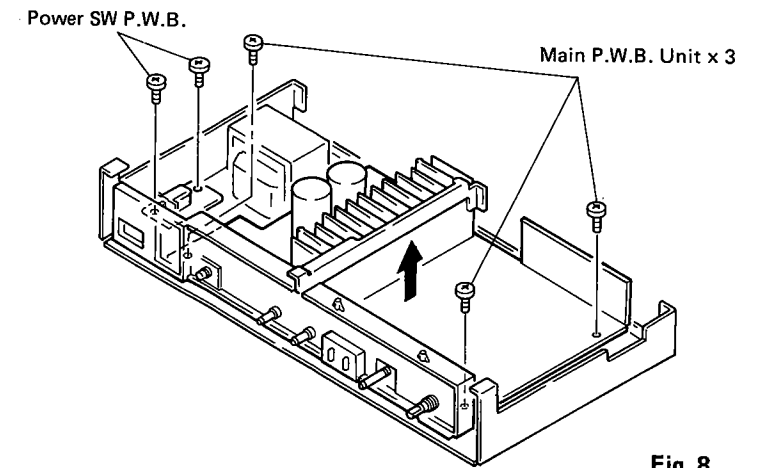

Fig. 8

5. How to remove the inner panel (Fig. 9)

- 1) Remove the two screws holding the inner panel in place.
- 2) Pull the inner panel toward you and remove it.

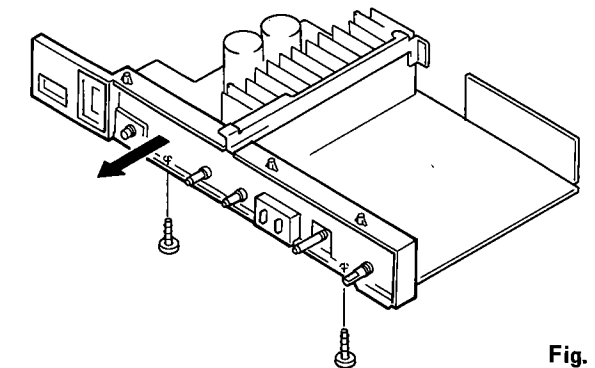
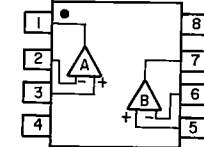
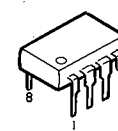

Fig. 9

SEMICONDUCTORS

• IC's

M-5218P (Mitsubishi)



μPC1225H (NEC)

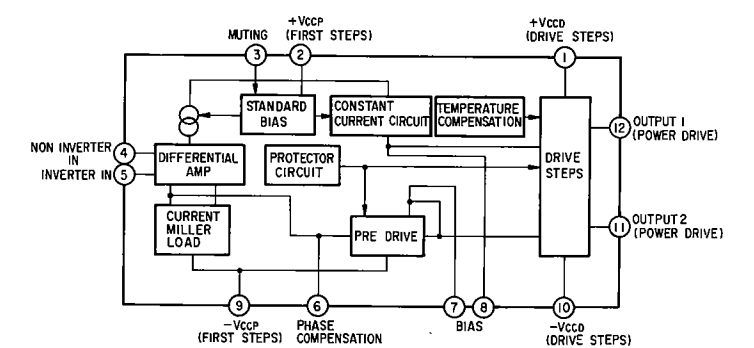
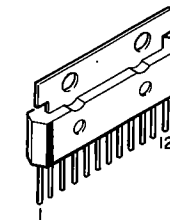

• TRANSISTORS

2SA1015(Y)
2SC1815(BL)
2SA999(F)
2SC2878(A)/(B)



B (Base)
C (Collector)
E (Emitter)

2SA1489(O/Y)
2SC3853(O/Y)



E (Emitter)
C (Collector)
B (Base)

• DIODES

1S2076A

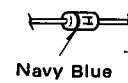

Navy Blue *

HZ5C-1
HZ18-2



Navy Blue *

PBL403

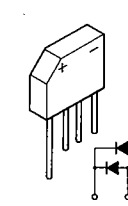

LT9213R (LED)

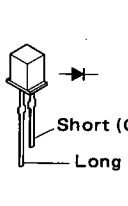

Short (Cathode)
Long (Anode)

PRINTED WIRING BOARD PATTERNS AND PARTS LIST
ETC0863 POWER & CONTROL UNIT (for E2)

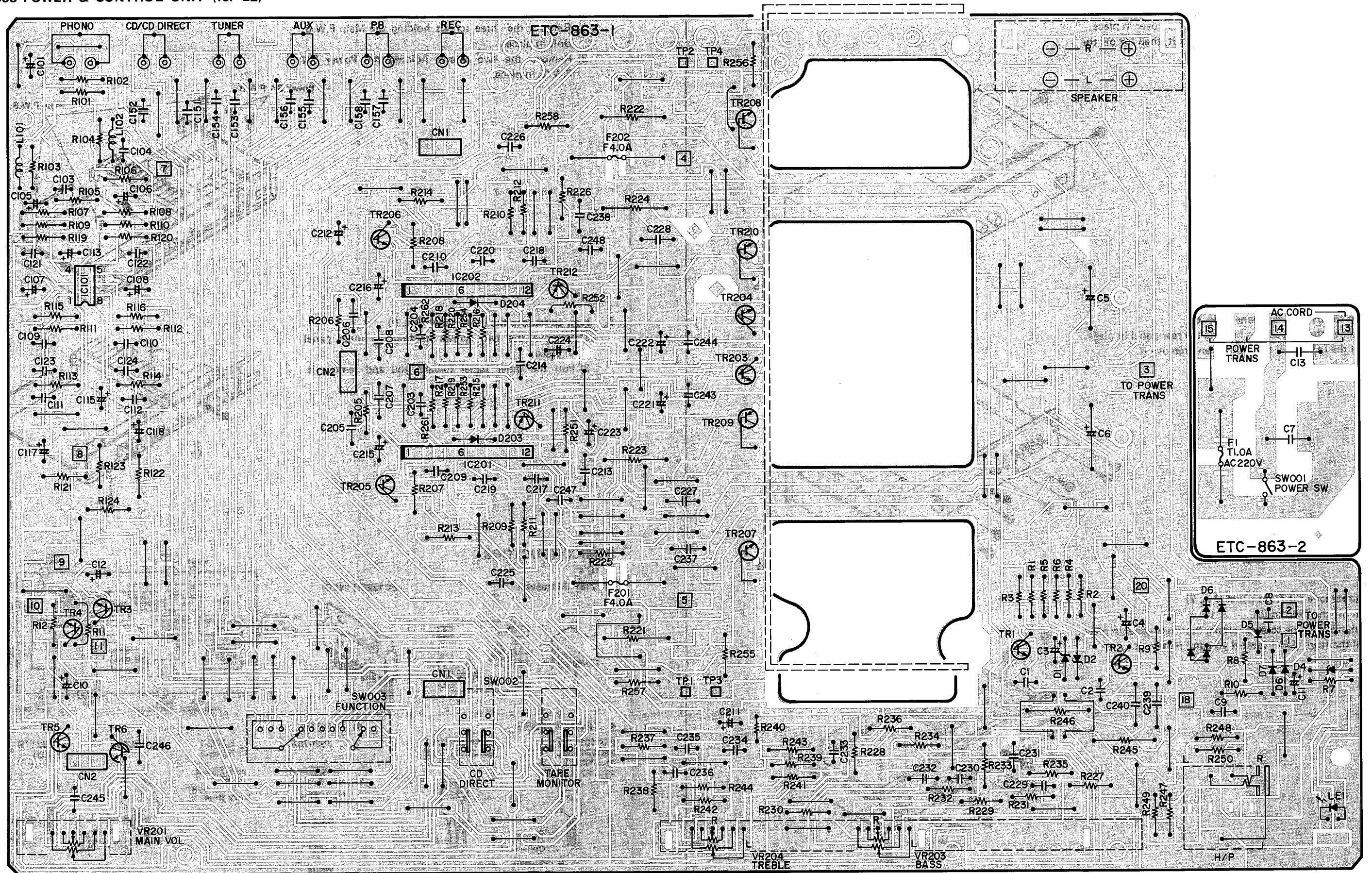

ETC0859 POWER & CONTROL UNIT (for EK)

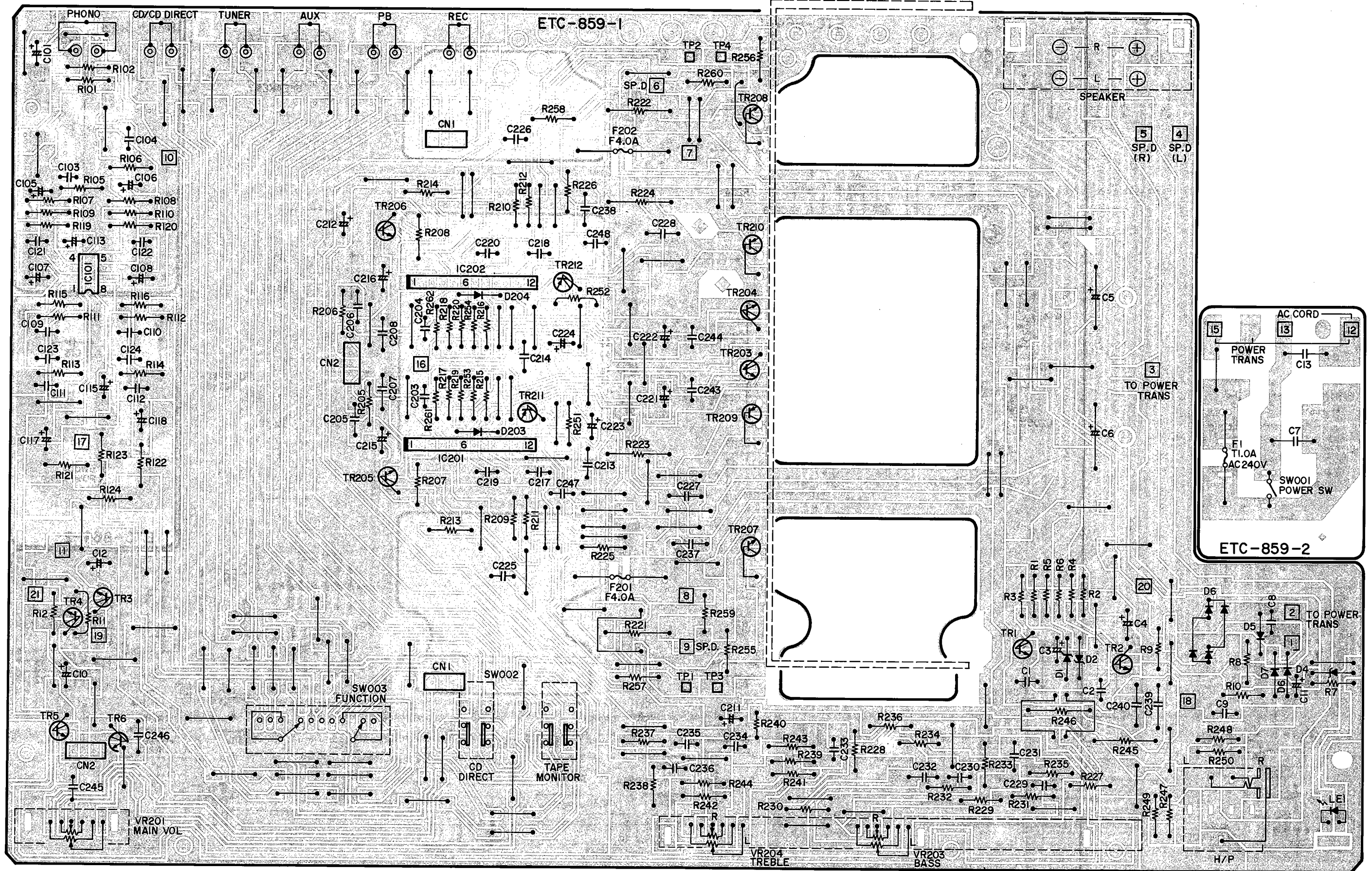

ETC864 POWER & CONTROL UNIT (for E1/EA)

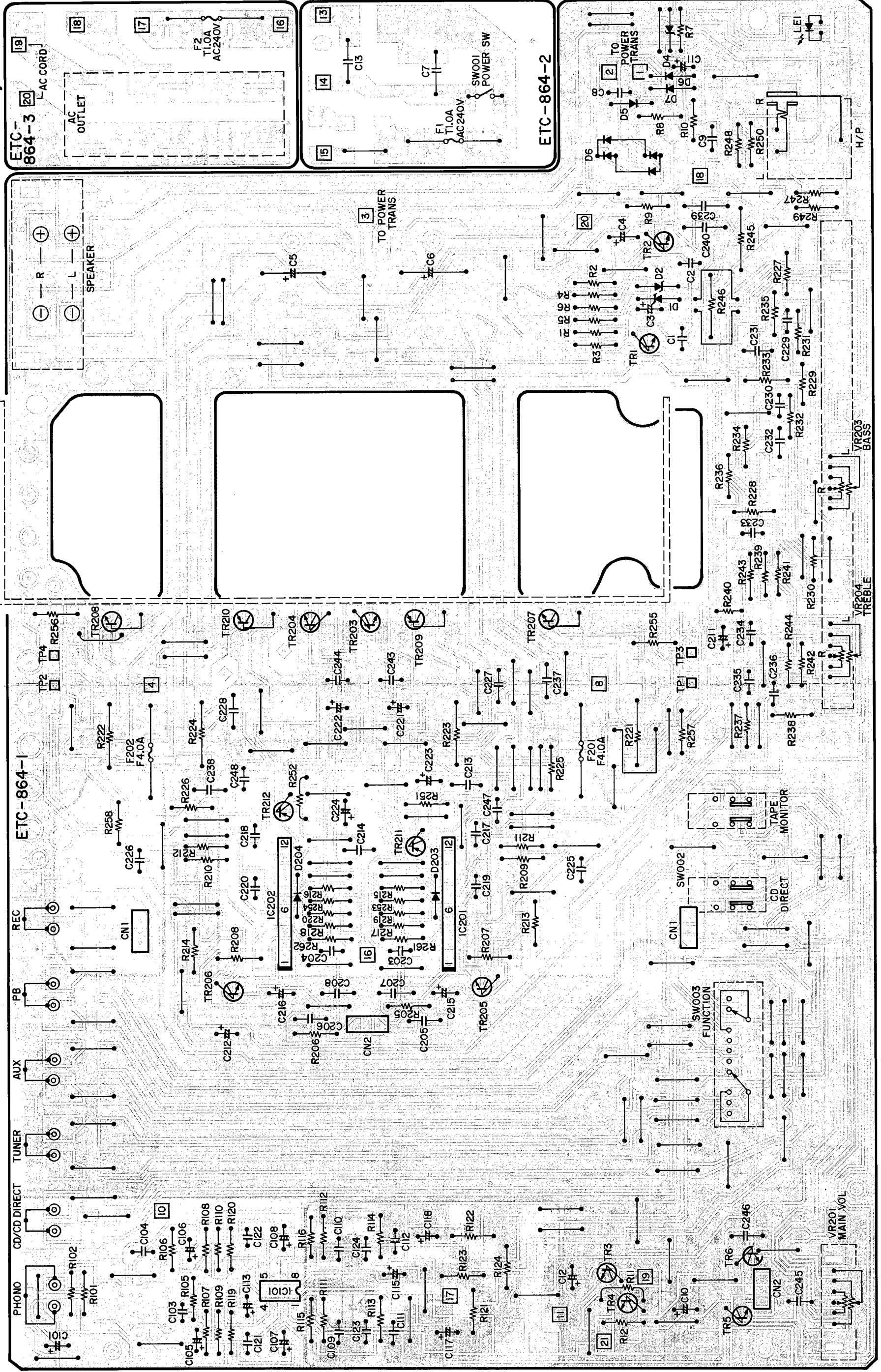

ETC0865 POWER & CONTROL UNIT (for EU/EC)

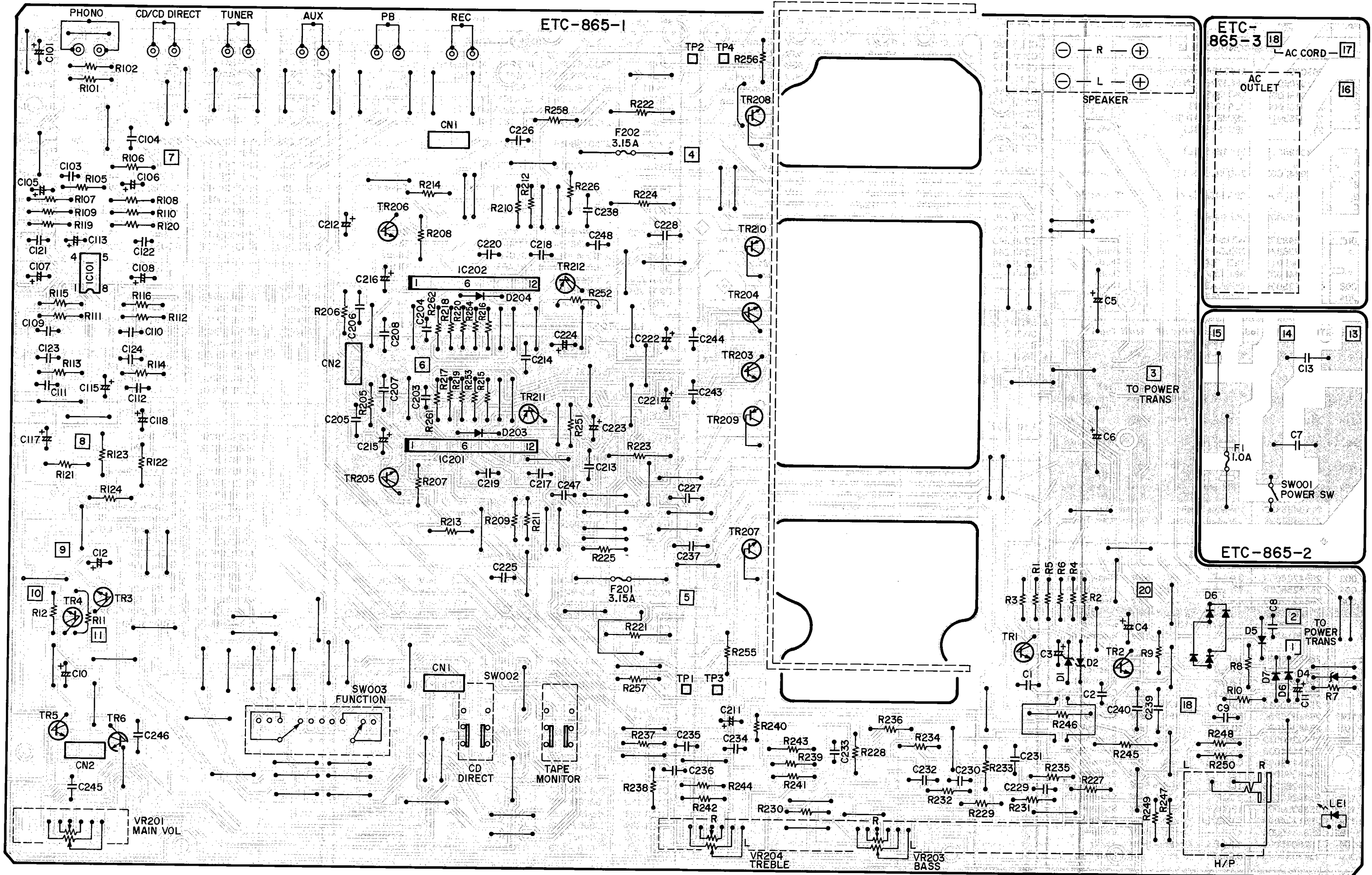

PRINTED WIRING BOARD PARTS LIST
ETC0863 POWER & CONTROL UNIT PARTS LIST (for E2)

Ref. No.	Part No.	Part Name & Descriptions				
SEMICONDUCTORS						
IC101	2630257001	M-5218P (Mitsubishi)	IC			
IC201,202	2630206007	μ PC1225H (NEC)	IC			
TR001	2730198002	2SC1815(Y)	Transistor			
TR002	2710102005	2SA1015(Y)	Transistor			
TR003	2730253015	2SC2878(A)/(B)	Transistor			
TR004 ~006	2730198015	2SC1815(BL)	Transistor			
TR203 ~206	2730198015	2SC1815(BL)	Transistor			
TR207, 208	2730343006	2SC3853(O/Y)	Transistor			
TR209, 210	2710213004	2SA1489(O/Y)	Transistor			
TR211, 212	2710113007	2SA999(F)	Transistor			
D001,002	2760249002	HZ18-2	Zener			
D004	2760236031	HZ5C-1	Zener			
D005	2760049011	1S2076A	Diode			
D006	2760448007	PBL403	Diode			
D007,008	2760433009	DSM1AZ	Diode			
D203,204	2760049011	1S2076A	Diode			
LE001	3939173005	LT9213R	LED			
RESISTORS (not included Carbon Film \pm5%, 1/4W Type)						
R001	2412314023	470 ohm \pm 5%	1/4W Carbon Film (NBF)			
R004	2412314023	470 ohm \pm 5%	1/4W Carbon Film (NBF)			
R010	2412370025	7.5k ohm \pm 5%	1/4W Carbon Film (NBF)			
R213,214	2412314023	470 ohm \pm 5%	1/4W Carbon Film (NBF)			
R221~224	2442013080	0.22 ohm \pm 5%	1W Metal Oxide (NBF)			
R245,246	2440017020	10 ohm \pm 5%	1W Metal Oxide (NBF)			
R251,252	2412314023	470 ohm \pm 5%	1/4W Carbon Film (NBF)			
VR201	2110485102	Variable Resistor 100k ohm Main				
VR203, 204	2110486004	Variable Resistor 100k ohm Bass Treble				
CAPACITORS						
C001,002	2554204088	0.01 μ F \pm 5%	50V Plastic Film			
C003,004	2544256059	220 μ F \pm 20%	25V Electrolytic			
C005,006	2544212019	8200 μ F \pm 20%	45V Electrolytic			
C007	2538014003	0.01 μ F \pm 20%	400V Ceramic (AC)			
C008	2531052004	0.0047 μ F \pm 100,-0%	500V Ceramic			
C009	2543014027	10 μ F \pm 20%	16V Electrolytic (B.P)			
C010	2544260045	1 μ F \pm 20%	50V Electrolytic			
C011	2544243004	0.47 μ F \pm 20%	50V Electrolytic			
C012	2544250005	470 μ F \pm 20%	6.3V Electrolytic			
C013	2538014003	0.01 μ F \pm 20%	400V Ceramic (AC)			
C101	2544260045	1 μ F \pm 20%	50V Electrolytic			
C103,104	2556075008	100pF \pm 5%	50V Styrene			
C105,106	2544254006	10 μ F \pm 20%	16V Electrolytic			
C107,108	2544250039	220 μ F \pm 20%	6.3V Electrolytic			
C109,110	2551134038	0.022 μ F \pm 5%	50V Plastic Film			
C111,112	2556119003	0.0068 μ F \pm 5%	50V Styrene			
C113	2544260045	1 μ F \pm 20%	50V Electrolytic			
C115	2544260045	1 μ F \pm 20%	50V Electrolytic			
C117,118	2544260058	2.2 μ F \pm 20%	50V Electrolytic			
C121,122	2536099000	1000pF \pm 5%	50V Styrene			
C123,124	2551134009	0.0022 μ F \pm 5%	50V Plastic Film			
C151~158	2533619005	47pF \pm 5%	50V Ceramic			
C203,204	2556075008	100pF \pm 5%	50V Styrene			
C205,206	2561035075	0.68 μ F \pm 5%	50V Metalized			

Ref. No.	Part No.	Part Name & Descriptions				
C207,208	2561035059	0.47 μ F \pm 20%	50V Electrolytic			
C209,210	2533627000	100pF \pm 5%	50V Ceramic			
C211,212	2544260045	1 μ F \pm 20%	50V Electrolytic			
C213,214	2561035059	0.47 μ F \pm 5%	50V Metalized			
C215,216	2544261028	100 μ F \pm 5%	50V Electrolytic			
C217,218	2554200040	150pF \pm 5%	50V Plastic Film			
C219,220	2533611003	22pF \pm 5%	50V Ceramic			
C221,222	2544254006	10 μ F \pm 20%	16V Electrolytic			
C223,224	2544261028	100 μ F \pm 20%	50V Electrolytic			
C225,226	2543014056	33 μ F \pm 20%	16V Electrolytic (B.P)			
C227,228	2561035059	0.47 μ F \pm 5%	50V Metalized			
C229,230	2551138005	0.033 μ F \pm 5%	50V Plastic Film			
C231,232	2551140064	0.12 μ F \pm 5%	50V Plastic Film			
C233,234	2591135037	0.0012 μ F \pm 5%	50V Plastic Film			
C235,236	2551134012	0.0056 μ F \pm 5%	50V Plastic Film			
C237,238	2561035059	0.47 μ F \pm 5%	50V Metalized			
C239,240	2554193005	0.1 μ F \pm 5%	50V Plastic Film			
C243,244	2554204088	0.01 μ F \pm 5%	50V Plastic Film			
C245,246	2561035075	0.68 μ F \pm 5%	50V Metalized			
C247,248	2556111001	0.0033 μ F \pm 5%	50V Styrene			
E.U.P.						
				Q'ty		
SW001	2124409006	Power Switch	Power	1		
SW002	2124633005	2P Push Switch	TAPE/CDD.	1		
SW003	2124632103	Rotary Switch (4-4)	Selector	1		
F001	2061015029	Fuse (1A T)		1		
F201,202	2061040049	Fuse (4A F)		2		
	2020031002	Fuse Holder		6		
	2048166001	Headphone Jack		1		
	2048226006	12P Pin Jack	For Inputs	1		
	2050351008	4P Terminal	For SP	1		
L101,102	2350016104	Inductor	18 μ H	2		
OTHER PARTS						
	2221409006	P.W. Board		1		
	2090008120	Jumper Wire P=10mm		123		
	EP-5667H1	Terminal Pin		15		
	4170278001	Power Radiator		1		
	4122111006	Bracket		1		
	4700012022	Pan Screw with SW.W 3x12		4		
	4700026005	Tapping Screw (2) 3x8		4		
	4737002005	Tapping Screw (S) 3x6		2		
	2034356016	3P Connector Cord		2		
	1460852004	Inner Panel		1		
	4150309013	P.V.C. Tube		20		
	2090152021	2C Ribbon Cable		1		
	1460866003	LED Holder		1		

ETC0859 POWER & CONTROL UNIT PARTS LIST (for EK)

Ref. No.	Part No.	Part Name & Descriptions				
SEMICONDUCTORS						
IC101	2630257001	M-5218P (Mitsubishi)	IC			
IC201,202	2630206007	μ PC1225H (NEC)	IC			
TR001	2730198002	2SC1815(Y)	Transistor			
TR002	2710102005	2SA1015(Y)	Transistor			
TR003	2730253015	2SC2878(A)/(B)	Transistor			
TR004 ~006	2730198015	2SC1815(BL)	Transistor			
TR203 ~206	2730198015	2SC1815(BL)	Transistor			
TR207, 208	2730343006	2SC3853(O/Y)	Transistor			
TR209, 210	2710213004	2SA1489(O/Y)	Transistor			
TR211, 212	2710113007	2SA999(F)	Transistor			
D001,002	2760249002	HZ18-2	Zener			
D004	2760236031	HZ5C-1	Zener			
D005	2760049011	1S2076A	Diode			
D006	2760448007	PBL403	Diode			
D007,008	2760433009	DSM1AZ	Diode			
D203,204	2760049011	1S2076A	Diode			
LE001	3939173005	LT9213R	LED			
RESISTORS (not included Carbon Film \pm5%, 1/4W Type)						
R001	2412314023	470 ohm \pm 5%	1/4W Carbon Film (NBF)			
R004	2412314023	470 ohm \pm 5%	1/4W Carbon Film (NBF)			
R010	2412370025	7.5k ohm \pm 5%	1/4W Carbon Film (NBF)			
R213,314	2412314023	470 ohm \pm 5%	1/4W Carbon Film (NBF)			
R221~224	2442013080	0.22 ohm \pm 5%	1W Metal Oxide (NBF)			
R245,246	2440017020	10 ohm \pm 5%	2W Metal Oxide (NBF)			
R251,252	2412314023	470 ohm \pm 5%	1/4W Carbon Film (NBF)			
R259,260	2432039029	0.22 ohm \pm 5%	5W Wire Wound			
VR201	2110485102	Variable Resistor 100k ohm Main				
VR203, 204	2110486004	Variable Resistor 100k ohm Bass Treble				
CAPACITORS						
C001,002	2554204088	0.01 μ F \pm 5%	50V Plastic Film			
C003,004	2544256059	220 μ F \pm 20%	25V Electrolytic			
C005,006	2544212019	8200 μ F \pm 20%	45V Electrolytic			
C007	2538014003	0.01 μ F \pm 20%	400V Ceramic (AC)			
C008	2531052004	0.0047 μ F \pm 100,-0%	500V Electrolytic			
C009	2543014027	10 μ F \pm 20%	16V Electrolytic (B.P)			
C011	2544243004	0.47 μ F \pm 20%	50V Electrolytic			
C012	2544250005	470 μ F \pm 20%	6.3V Electrolytic			
C013	2538014003	0.01 μ F \pm 20%	400V Ceramic (AC)			
C101	2544260045	1 μ F \pm 20%	50V Electrolytic			
C103,104	2556084002	240pF \pm 5%	50V Styrene			
C105,106	2544254006	10 μ F \pm 20%	16V Electrolytic			
C107,108	2544250039	220 μ F \pm 20%	6.3V Electrolytic			
C109,110	2551134038	0.022 μ F \pm 5%	50V Plastic Film			
C111,112	2556119003	6800pF \pm 5%	50V Styrene			
C113	2544260045	1 μ F \pm 20%	50V Electrolytic			
C115	2544260045	1 μ F \pm 20%	50V Electrolytic			
C117,118	2544260058	2.2 μ F \pm 20%	50V Electrolytic			
C121,122	2536099000	1000pF \pm 5%	50V Styrene			
C123,124	2551134009	0.0022 μ F \pm 5%	50V Plastic Film			
C203,204	2556075008	100pF \pm 5%	50V Styrene			
C205,206	2561035075	0.68 μ F \pm 5%	50V Metalized			
C207,208	2561035059	0.47 μ F \pm 20%	50V Electrolytic			

Ref. No.	Part No.	Part Name & Descriptions				Q'ty
C211,212	2544260045	1 μ F	\pm 20%	50V Electrolytic		
C213,214	2561035059	0.47 μ F	\pm 5%	50V Metalized		
C215,216	2544261028	100 μ F	\pm 20%	50V Electrolytic		
C217,218	2554200040	150pF	\pm 5%	50V Plastic Film		
C219,220	2533603008	10pF	\pm 5%	50V Ceramic		
C221,222	2544254006	10 μ F	\pm 20%	16V Electrolytic		
C223,224	2544161028	100 μ F	\pm 20%	50V Electrolytic		
C225,226	2543014056	33 μ F	\pm 20%	16V Electrolytic (B.P)		
C227,228	2561035059	0.47 μ F	\pm 5%	50V Metalized		
C229,230	2551138005	0.033 μ F	\pm 5%	50V Plastic Film		
C231,232	2551140064	0.12 μ F	\pm 5%	50V Plastic Film		
C233,234	2591135037	0.0012 μ F	\pm 5%	50V Plastic Film		
C235,236	2551134012	0.0056 μ F	\pm 5%	50V Plastic Film		
C237,238	2561035059	0.47 μ F	\pm 5%	50V Metalized		
C239,240	2554193005	0.1 μ F	\pm 5%	50V Plastic Film		
C243,244	2554204088	0.01 μ F	\pm 5%	50V Plastic Film		
C245,246	2561035075	0.6				

ETC0864 POWER & CONTROL UNIT PARTS LIST (for E1/EA)

Ref. No.	Part No.	Part Name & Descriptions	
SEMICONDUCTORS			
IC101	2630257001	M-5218P (Mitsubishi)	IC
IC201,202	2630206007	μPC1225H (NEC)	IC
TR001	2730198002	2SC1815(Y)	Transistor
TR002	2710102005	2SA1015(Y)	Transistor
TR003	2730253015	2SC2878(A)/(B)	Transistor
TR004 ~006	2730198015	2SC1815(BL)	Transistor
TR203 ~206	2730198015	2SC1815(BL)	Transistor
TR207, 208	2730343006	2SC3853(O/Y)	Transistor
TR209, 210	2710213004	2SA1489(O/Y)	Transistor
TR211, 212	2710113007	2SA999(F)	Transistor
D001,002	2760249002	HZ18-2	Zener
D004	2760236031	HZ5C-1	Zener
D005	2760049011	1S2076A	Diode
D006	2760448007	PBL403	Diode
D007,008	2760433009	DSM1AZ	Diode
D203,204	2760049011	1S2076A	Diode
LE001	3939173005	LT9213R	LED
RESISTORS (not included Carbon Film ±5%, 1/4W Type)			
Δ R001	2412314023	470 ohm ±5%	1/4W Carbon Film (NBF)
Δ R004	2412314023	470 ohm ±5%	1/4W Carbon Film (NBF)
Δ R010	2412370025	7.5k ohm ±5%	1/4W Carbon Film (NBF)
Δ R213,214	2412314023	470 ohm ±5%	1/4W Carbon Film (NBF)
Δ R221~224	2442013080	0.22 ohm ±5%	1W Metal Oxide (NBF)
Δ R245,246	2440017020	10 ohm ±5%	1W Metal Oxide (NBF)
Δ R251,252	2412314023	470 ohm ±5%	1/4W Carbon Film (NBF)
VR201	2110485102	Variable Resistor 100k ohm Main	
VR203, 204	2110486004	Variable Resistor 100k ohm Bass Treble	
CAPACITORS			
C001,002	2554204088	0.01μF ±5%	50V Plastic Film
C003,004	2544256059	220μF ±20%	25V Electrolytic
C005,006	2544212019	8200μF ±20%	45V Electrolytic
Δ C007	2538014003	0.01μF ±20%	400V Ceramic (AC)
C008	2531052004	0.0047μF ±100,-0%	500V Electrolytic
C009	2543014027	10μF ±20%	16V Electrolytic (B.P)
C011	2544243004	0.47μF ±20%	50V Electrolytic
C012	2544250005	470μF ±20%	6.3V Electrolytic
C013	2538014003	0.01μF ±20%	400V Ceramic (AC)
C101	2544260045	1μF ±20%	50V Electrolytic
C103,104	2556084002	240pF ±5%	50V Styrene
C105,106	2544254006	10μF ±20%	16V Electrolytic
C107,108	2544250039	220μF ±20%	6.3V Electrolytic
C109,110	2551134038	0.022μF ±5%	50V Plastic Film
C111,112	2556119003	6800pF ±5%	50V Styrene
C113	2544260045	1μF ±20%	50V Electrolytic
C115	2544260045	1μF ±20%	50V Electrolytic
C117,118	2544260058	2.2μF ±20%	50V Electrolytic
C121,122	2536099000	1000pF ±5%	50V Styrene
C123,124	2551134009	0.0022μF ±5%	50V Plastic Film
C203,204	2556075008	100pF ±5%	50V Styrene
C205,206	2561035075	0.68μF ±5%	50V Metalized
C207,208	2561035059	0.47μF ±20%	50V Electrolytic
C211,212	2544260045	1μF ±20%	50V Electrolytic

ETC0865 POWER & CONTROL UNIT PARTS LIST (for EU/EC)

Ref. No.	Part No.	Part Name & Descriptions	
C213,214	2561035059	0.47μF ±5%	50V Metalized
C215,216	2544261028	100μF ±20%	50V Electrolytic
C217,218	2554200040	150pF ±5%	50V Plastic Film
C219,220	2533603008	10pF ±5%	50V Ceramic
C221,222	2544254006	10μF ±20%	16V Electrolytic
C223,224	2544161028	100μF ±20%	50V Electrolytic
C225,226	2543014056	33μF ±20%	16V Electrolytic (B.P)
C227,228	2561035059	0.47μF ±5%	50V Metalized
C229,230	2551138005	0.033μF ±5%	50V Plastic Film
C231,232	2551140064	0.12μF ±5%	50V Plastic Film
C233,234	2591135037	0.0012μF ±5%	50V Plastic Film
C235,236	2551134012	0.0056μF ±5%	50V Plastic Film
C237,238	2561035059	0.47μF ±5%	50V Metalized
C239,240	2554193005	0.1μF ±5%	50V Plastic Film
C243,244	2554204088	0.01μF ±5%	50V Plastic Film
C245,246	2561035075	0.68μF ±5%	50V Metalized
C247,248	2556111001	0.0033μF ±5%	50V Styrene
E.U.P.			
Δ SW001	2124409006	Power Switch	Power
SW002	2124633005	2P Push Switch	TAPE/CDD.
SW003	2124632006	Rotary Switch (4-4)	Selector
F001	2061015029	Fuse (1A T)	
F201,202	2061040049	Fuse (4A F)	
Δ 2020031002	2020031002	Fuse Holder (for E1)	6
Δ 2020031002	2020031002	Fuse Holder (for EA)	8
2048166001	2048166001	Headphone Jack	1
2048226006	2048226006	12P Pin Jack	For Input
2050351008	2050351008	4P Terminal	For SP
Δ 2033932004	2033932004	AC Outlet (3P)	(for E1)
Δ F002	2061015029	Fuse (1A T)	(for EA)
OTHER PARTS			
	2221426001	P.W. Board	1
	2090008120	Jumper Wire P=10mm	123
	EP-5667H1	Terminal Pin	22
	4170278001	Power Radiator	1
	4122111006	Bracket	1
	4700012022	Pan Screw with S.W.S 3x12	4
	4700026005	Tapping Screw (2) 3x8	4
	4737002005	Tapping Screw (S) 3x6	2
	2034356016	3P Connector Cord	2
	1460852004	Inner Panel	1
	4150309013	P.V.C. Tube	20
	2090152021	2C Ribbon Cable	1
	1460866003	LED Holder	1

Ref. No.	Part No.	Part Name & Descriptions	
SEMICONDUCTORS			
IC101	2630257001	M-5218P (Mitsubishi)	IC
IC201,202	2630206007	μPC1225H (NEC)	IC
TR001	2730198002	2SC1815(Y)	Transistor
TR002	2710102005	2SA1015(Y)	Transistor
TR003	2730253015	2SC2878(A)/(B)	Transistor
TR004 ~006	2730198015	2SC1815(BL)	Transistor
TR203 ~206	2730198015	2SC1815(BL)	Transistor
TR207, 208	2730343006	2SC3853(O/Y)	Transistor
TR209, 210	2710213004	2SA1489(O/Y)	Transistor
TR211, 212	2710113007	2SA999(F)	Transistor
D001,002	2760249002	HZ18-2	Zener
D004	2760236031	HZ5C-1	Zener
D005	2760049011	1S2076A	Diode
D006	2760448007	PBL403	Diode
D007,008	2760433009	DSM1AZ	Diode
D203,204	2760049011	1S2076A	Diode
LE001	3939173005	LT9213R	LED
RESISTORS (not included Carbon Film ±5%, 1/4W Type)			
Δ R001	2412314023	470 ohm ±5%	1/4W Carbon Film (NBF)
Δ R004	2412314023	470 ohm ±5%	1/4W Carbon Film (NBF)
R008	2410192001	2k ohm ±5%	1/2W Carbon Film
Δ R010	2412370025	7.5k ohm ±5%	1/4W Carbon Film (NBF)
Δ R213,214	2412314023	470 ohm ±5%	1/4W Carbon Film (NBF)
Δ R221~224	2442013080	0.22 ohm ±5%	1W Metal Oxide (NBF)
Δ R245,246	2440017020	10 ohm ±5%	1W Metal Oxide (NBF)
Δ R251,252	2412314023	470 ohm ±5%	1/4W Carbon Film (NBF)
VR201	2110485102	Variable Resistor 100k ohm Main	
VR203, 204	2110486004	Variable Resistor 100k ohm Bass, Treble	
CAPACITORS			
C001,002	2554204088	0.01μF ±5%	50V Plastic Film
C003,004	2544256059	220μF ±20%	25V Electrolytic
C005,006	2544212019	8200μF ±20%	45V Electrolytic
Δ C007	2538014003	0.01μF ±20%	400V Ceramic (AC)
C008	2531052004	0.0047μF ±100,-0%	500V Electrolytic
C009	2543014027	10μF ±20%	16V Electrolytic (B.P)
C011	2544243004	0.47μF ±20%	50V Electrolytic
C012	2544250005	470μF ±20%	6.3V Electrolytic
C013	2538014003	0.01μF ±20%	400V Ceramic (AC)
C101	2544260045	1μF ±20%	50V Electrolytic
C103,104	2556084002	240pF ±5%	50V Styrene
C105,106	2544254006	10μF ±20%	16V Electrolytic
C107,108	2544250039	220μF ±20%	6.3V Electrolytic
C109,110	2551134038	0.022μF ±5%	50V Plastic Film
C111,112	2556119003	6800pF ±5%	50V Styrene
C113	2544260045	1μF ±20%	50V Electrolytic
C115	2544260045	1μF ±20%	50V Electrolytic
C117,118	2544260058	2.2μF ±20%	50V Electrolytic
C121,122	2536099000	1000pF ±5%	50V Styrene
C123,124	2551134009	0.0022μF ±5%	50V Plastic Film
C203,204	2556075008	100pF ±5%	50V Styrene
C205,206	2561035075	0.68μF ±5%	50V Metalized
C207,208	2561035059	0.47μF ±20%	50V Electrolytic

Ref. No.	Part No.	Part Name & Descriptions	
C211,212	2544260045	1μF ±20%	50V Electrolytic
C213,214	2561035059	0.47μF ±5%	50V Metalized
C215,216	2544261028	100μF ±20%	50V Electrolytic
C217,218	2554200040	150pF ±5%	50V Plastic Film
C219,220	2533603008	10pF ±5%	50V Ceramic
C221,222	2544254006	10μF ±20%	16V Electrolytic
C223,224	2544161028	100μF ±20%	50V Electrolytic
C225,226	2543014056	33μF ±20%	16V Electrolytic (B.P)
C227,228	2561035059	0.47μF ±5%	50V Metalized
C229,230	2551138005	0.033μF ±5%	50V Plastic Film
C231,232	2551140064	0.12μF ±5%	50V Plastic Film
C233,234	2591135037	0.0012μF ±5%	50V Plastic Film
C235,236	2551134012	0.0056μF ±5%	50V Plastic Film
C237,238	2561035059	0.47μF ±5%	50V Metalized
C239,240	2554193005	0.1μF ±5%	50V Plastic Film
C243,244	2554204088	0.01μF ±5%	50V Plastic Film
C245,246	2561035075	0.68μF ±5%	50V Metalized
C247,248	2556111001	0.0033μF ±5%	50V Styrene
SWITCH			
Δ SW001	2124409006	Power Switch	Power
SW002	2124633005	2P Push Switch	Tape/CD,D
SW003	2124632006	Rotary Switch (4-4)	Selector
E.U.P.			
Δ F001	2061039034	Fuse 1.0A	1
F201,202	2061039089	Fuse 3.15A	2
Δ 2020031002	2020031002	Fuse Holder	6
2048166001	2048166001	Headphone Jack	1
2048226006	2048226006	12P Pin Jack	Input
2050351008	2050351008	4P Terminal	SP
2033932004	2033932004	AC Outlet (3P)	1
OTHER PARTS			
	2221443004	P.W. Board	1
	2090008120	Jumper Wire P=10mm	122
	EP-5667H1	Terminal Pin	20
	1460866003	LED Holder	1
	4170278108	Power Radiator	1
	4122111006	Bracket	1
	4700012022	Pan Screw with S.W.W 3x12	4
	4700026005	Tapping Screw 3x8	4
	4737002005	Tapping Screw 3x6	2
	2034356016	3P Connector Cord	2
CN001, 002	2090152021	2C Ribbon Cable	1
	4150309013	P.V.C Tube	20

WIRING DIAGRAM

Version	Unit No.
E2	ETC0863
EK	ETC0859
E1/EA	ETC0864
EU/EC	ETC0865

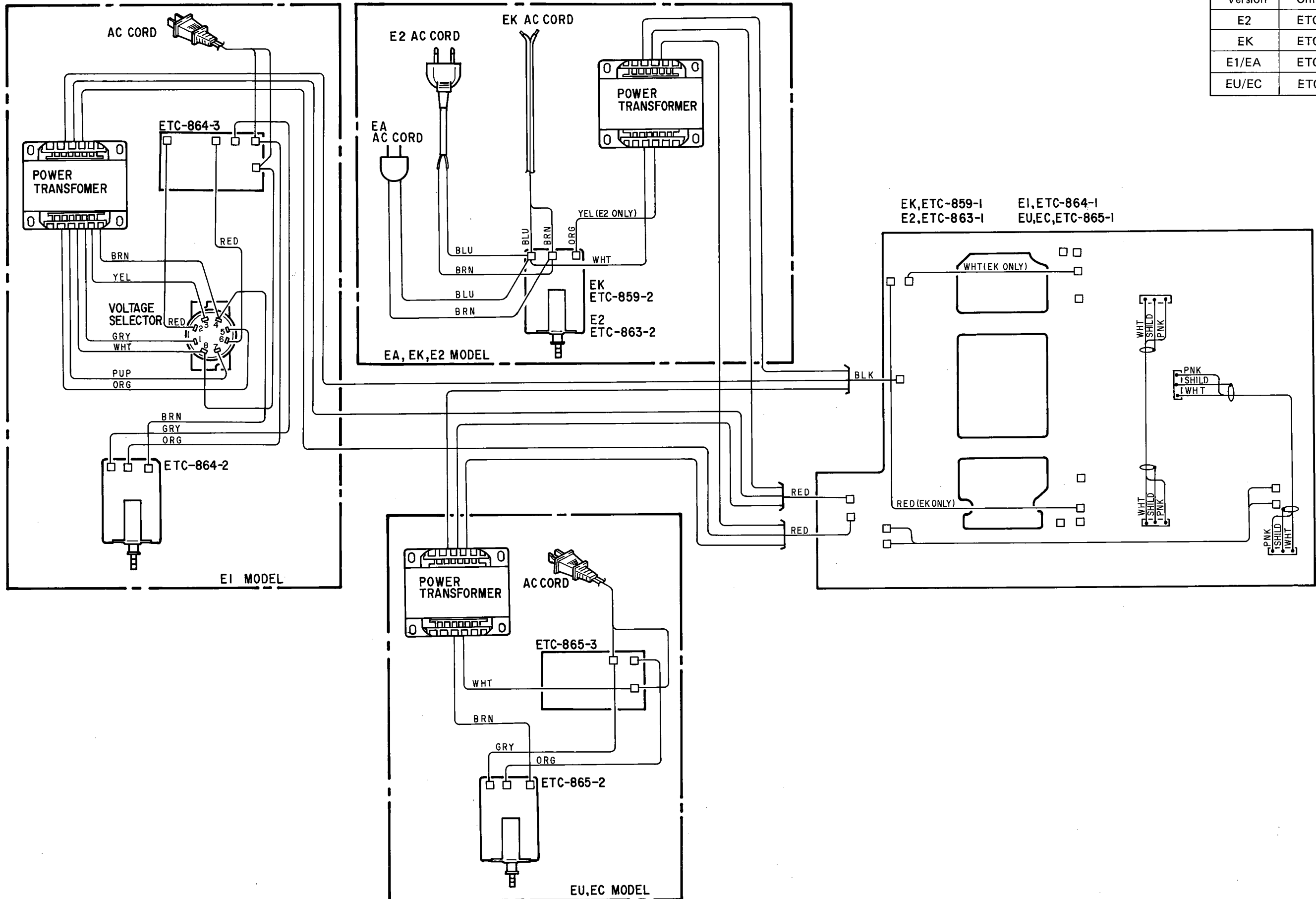

ADDENDUM LIST

Ref. No.	Part Name & Descriptions	Part No.					
		EK for UK	E1 for Asia	EF for France	EU for U.S.A.	EC for Canada	EA for Australia
5	POWER & CONTROL UNIT	ETC0859	ETC0864	ETC0859	ETC0865	ETC0865	ETC0864
▲ 9	POWER TRANS	2335570009	2935583009	2335576003	2335584008	2335584008	2335570009
10	BACK PANEL	1050694009	1050718008	1050694009	1050719007	1050719007	1050694009
▲ 13	AC CORD	2062051008	2062048008	2062047009	2062050009	2062050009	2062025005
▲ 14	CORD BUSH	4450056008	4450056008	4450056008	4450056008	4450056008	4450056008
▲ 30	AC OUTLET (3P)	—	2033932004	—	2033932004	2033932004	—
▲ 31	VOLTAGE SEL SW	—	2120186022	—	—	—	—
32	LABEL (A) TAIWAN	—	5131227003	—	—	—	—
33	LABEL (B) TAIWAN	—	5131228002	—	—	—	—
34	FUSE LABEL	—	—	—	5131245001	5131245001	—
35	VINYL WIRE (ORG)	—	2090183029	—	2090183029	2090183029	—
36	VINYL WIRE (GRY)	—	2090183032	—	2090183032	2090183032	—
37	VINYL WIRE (RED)	—	2090183045	—	—	—	—
38							
39							
40							
41							
42							
43							
53	TAPPING SCREW (S) 3x8	4737002021 (16)	4737002021 (18)	473002021 (16)	4737002021 (16)	4737002021 (16)	4737002021 (16)
103	CARTON CASE	5011137006	5011137022	5011137019	5011137035	5011137035	5011137006
107	CONTROL CARD	5131167008	5131167008	5131167008	—	—	5131167008
110	WARRANTY IN ENVELOPE	—	—	—	5150400005	—	—
111	DCI WARRANTY	—	—	—	—	5150399006	—

ATIC DIAGRAM

1 2 3 4 5 6

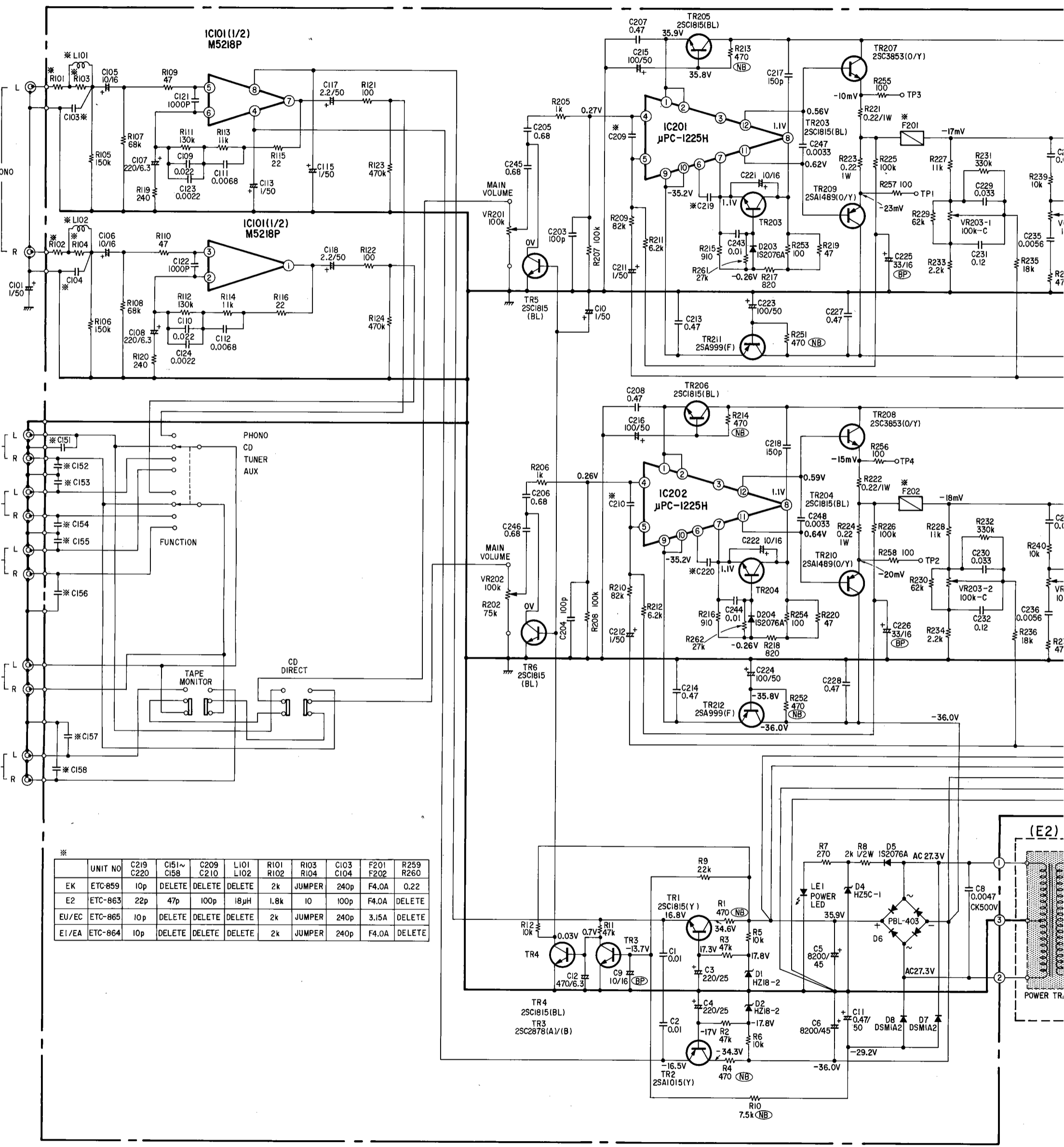

UNIT NO	C219	C151~C158	C209	L101	R101	R103	C103	F201	R259
EK	ETC-859	10p	DELETE	DELETE	2k	JUMPER	240p	F4.0A	0.22
E2	ETC-863	22p	47p	100p	18μH	1.8k	100p	F4.0A	DELETE
EU/EC	ETC-865	10p	DELETE	DELETE	2k	JUMPER	240p	3.15A	DELETE
E1/EA	ETC-864	10p	DELETE	DELETE	2k	JUMPER	240p	F4.0A	DELETE

(E2)
POWER TR.

 Means important safety item, which must be replaced, when necessary, by a part specified or meeting the specification by the manufacturer.

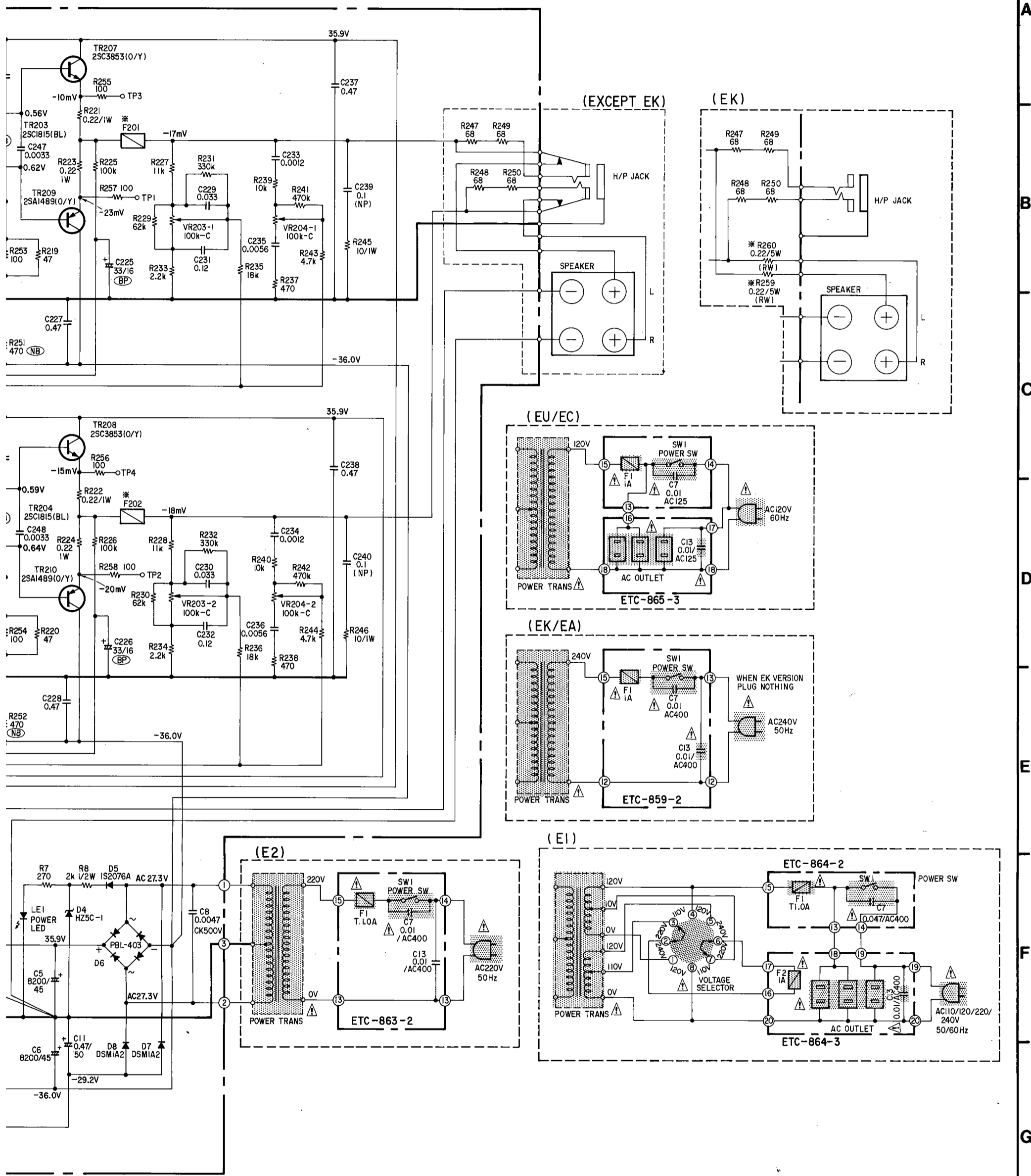

NOTES
 ALL RESISTANCE VALUES IN OHM K = 1,000 OHM M = 1,000,000 OHM
 ALL CAPACITANCE VALUES IN MICRO FARAD P = MICRO-MICRO FARAD
 EACH VOLTAGE AND CURRENT ARE MEASURED AT NO SIGNAL INPUT CONDITION.
 CIRCUIT AND PARTS ARE SUBJECT TO CHANGE WITHOUT PRIOR NOTICE.

EXPLODED VIEW OF CHASSIS AND CABINET

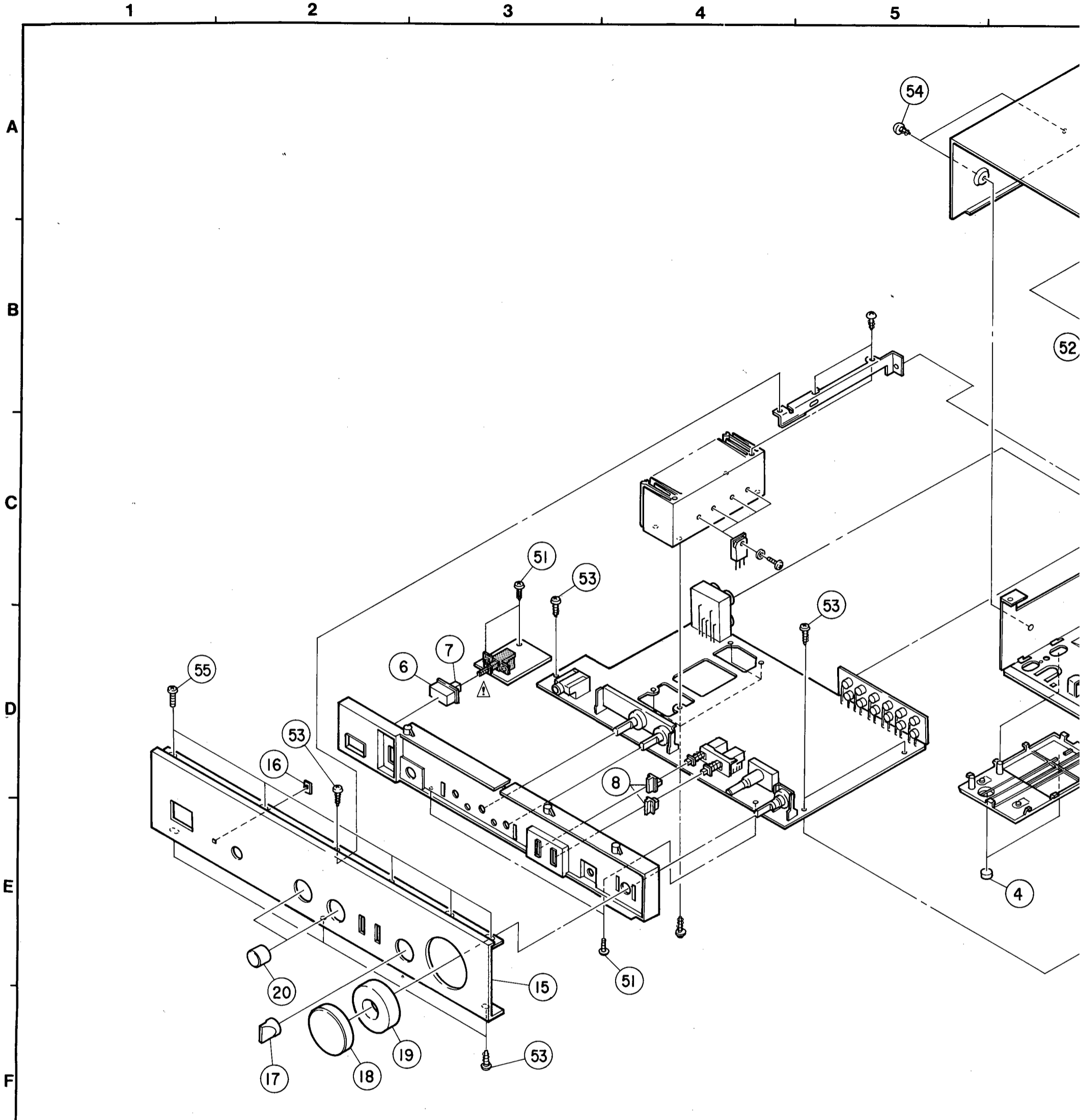

- Note 1. See addendum list right side for the parts with asterisk (*) on the Ref. No. and the other parts not included in the list.
 2. * marked not included EXPLODED VIEW OF CHASSIS AND CABINET.
 3. This list is prepared based on E2 BLACK VERSION.
 4. • indicates the parts newly used in this unit.

EXPLODED VIEW OF CHASSIS AND CABINET

E2 GOLD VERSION PARTS LIST
 (Same as BLACK VERSION except the followings.)

Ref. No.	Part No.	Part Name & Descriptions	Q'ty
1	• 4110595003	CHASSIS	1
2	• 1030948005	BOTTOM COVER (A)	1
3	• 1030949004	BOTTOM COVER (B)	1
4	• 4610162004	FELT PAD	4
*5	• ETC0863	POWER & CONTROL UNIT	1
6	• 1130854002	PUSH KNOB (P)	1
7	• 1190058000	KNOB JOINT	1
8	• 1130867002	PUSH KNOB (D)	2
Δ *9	• 2335576003	POWER TRANS	1
*10	• 1050717009	BACK PANEL	1
11	• 2050071016	TERMINAL ASS'Y	1
12	• 4770016001	WASHER (P-87)	1
Δ *13	• 2062047009	AC CORD	1
Δ *14	• 4450056008	CORD BUSH	1
15	• 1441542003	FRONT PANEL	1
16	• 1430490001	LENS	1
17	• 1120494003	KNOB (D)	1
18	• 1120497000	KNOB (VOLUME L)	1
19	• 1120498009	KNOB (VOLUME R)	1
20	• 1120492005	KNOB (B)	2
21	• 1020263004	TOP COVER	1
22			

Ref. No.	Part No.	Part Name & Descriptions	Q'ty
SCREWS			
51	• 4737508017	TAPPING SCREW (P) 3x10	4
52	• 4730453017	TAPPING SCREW (2) 4x8	4
53	• 4737002021	TAPPING SCREW (S) 3x8	16
54	• 4734454038	TRUSS SCREW (2) 4x8	4
55	• 4770281003	FIXING SCREW	6
PACKING & ACCESSORIES (not included EXPLODED VIEW)			
101	• 5050133003	CABINET COVER	1
102	• 5030577003	CUSHION	2
*103	• 5011137006	CARTON CASE	1
104	•		1
105	• 5111469001	INST. MANUAL	1
106	• 5139111014	COLOR LABEL (BLACK)	2
*107	• 5131167008	CONTROL CARD	1

Ref. No.	Part No.	Part Name & Descriptions	Q'ty
6	• 1130854015	PUSH KNOB (P)	1
8	• 1130867015	PUSH KNOB (D)	1
15	• 1441542016	FRONT PANEL	1
17	• 1120494016	KNOB (D)	1
18	• 1120497013	KNOB (VOLUME L)	1
19	• 1120498012	KNOB (VOLUME R)	1
20	• 1120492018	KNOB (B)	1
21	• 1020263017	TOP COVER	1
103	• 5011137048	CARTON CASE	1
106	• 5139110001	COLOR LABEL (GOLD)	1

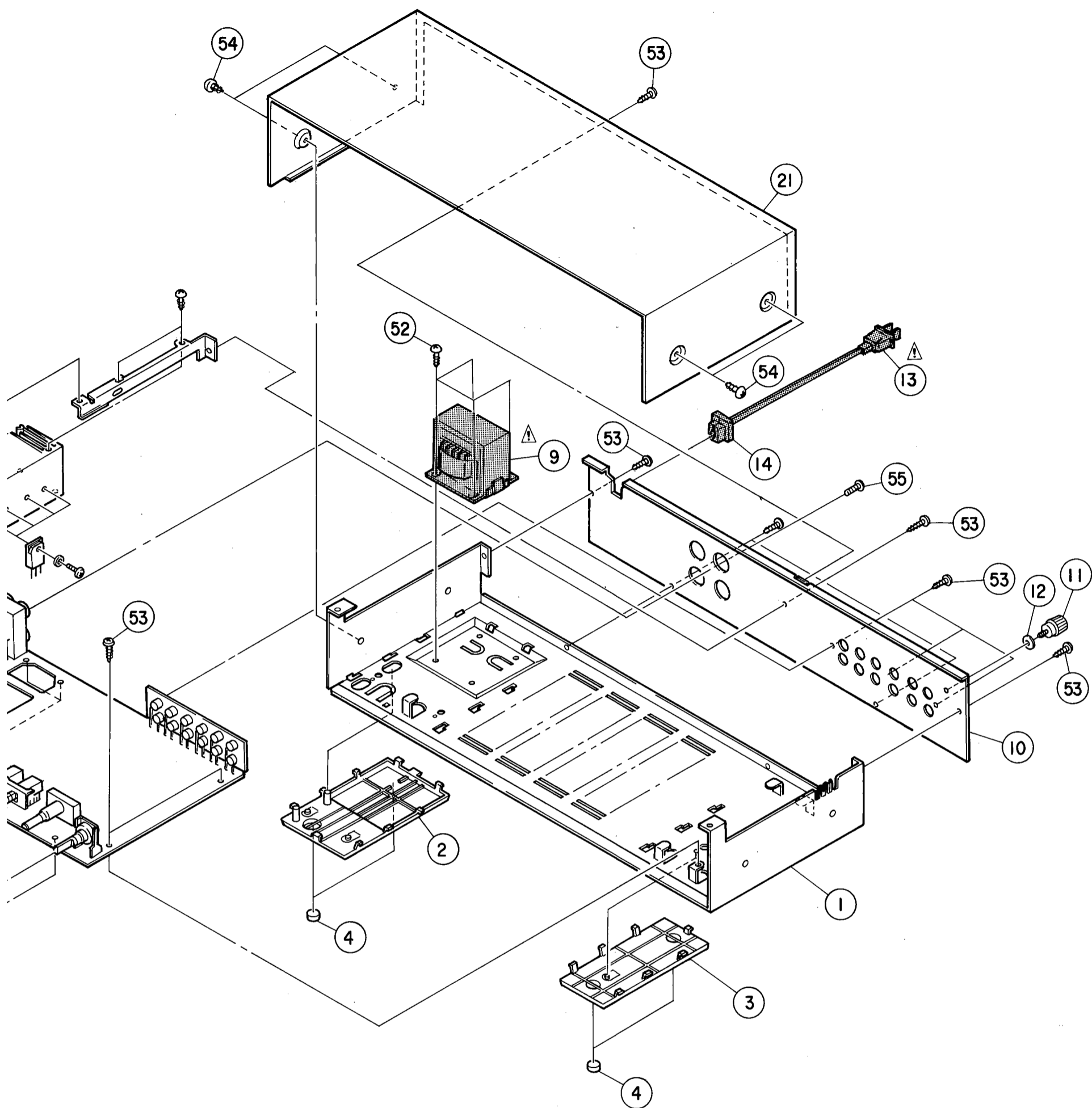

the Ref. No. and the other parts not included in the list.
CABINET.

E2 GOLD VERSION PARTS LIST
(Same as BLACK VERSION except the followings.)

Ref. No.	Part No.	Part Name & Descriptions	Q'ty
6	• 1130854015	PUSH KNOB (P)	1
8	• 1130867015	PUSH KNOB (D)	2
15	• 1441542016	FRONT PANEL	1
17	• 1120494016	KNOB (D)	1
18	• 1120497013	KNOB (VOLUME L)	1
19	• 1120498012	KNOB (VOLUME R)	1
20	• 1120492018	KNOB (B)	2
21	• 1020263017	TOP COVER	1
103	• 5011137048	CARTON CASE	1
106	5139110001	COLOR LABEL (GOLD)	2

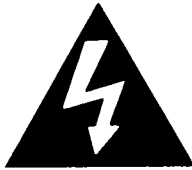

CAUTION
RISK OF ELECTRIC SHOCK
DO NOT OPEN



CAUTION: TO REDUCE THE RISK OF ELECTRIC SHOCK, DO NOT REMOVE COVER (OR BACK). NO USER SERVICEABLE PARTS INSIDE. REFER SERVICING TO QUALIFIED SERVICE PERSONNEL.



The lightning flash with arrowhead symbol within an equilateral triangle is intended to alert the user of the presence of uninsulated "dangerous voltage" within the product's enclosure that may be of sufficient magnitude to constitute a risk of electric shock to persons.



The exclamation point within an equilateral triangle is intended to alert the user of the presence of important operating and maintenance (servicing) instruction in the literature accompanying the appliance.

**WARNING: TO PREVENT FIRE OR SHOCK HAZARD.
DO NOT EXPOSE THIS APPLIANCE TO RAIN OR MOISTURE.**

For United Kingdom model only.

WARNING:

As the colours of the wires in the mains lead of this appliance may not correspond with the coloured markings identifying the terminals in your plug proceed as follows:

The wire which is coloured blue must be connected to the terminal which is marked with the letter N or coloured black.
The wire which is coloured brown must be connected to the terminal which is marked with the letter L or coloured red.

The wire which is coloured BROWN must be connected to the terminal which is marked with the letter L or coloured RED.

IMPORTANT

The wires in this mains lead are coloured in accordance with the following code:

Blue: Neutral
Brown: Live

To prevent the degradation of sound quality, DENON PMA-250 employs "DIRECT CONNECTION" from the power amplifier output to the speaker Terminal. Accordingly, when using headphones for private listening it will be necessary to disconnect your loud speaker leads from the amplifier.

For U.S.A. and Canada models.

CAUTION

TO PREVENT ELECTRIC SHOCK DO NOT USE THIS (POLARIZED) PLUG WITH AN EXTENSION CORD, RECEPTACLE OR OTHER OUTLET UNLESS THE BLADES CAN BE FULLY INSERTED TO PREVENT BLADE EXPOSURE.

NIPPON COLUMBIA CO., LTD.
No. 14-14, 4-CHOME AKASAKA,
MINATO-KU, TOKYO 107 JAPAN

TEL: 03-584-8111
TLX: JAPANOLA J22591
CABLE: NIPPONCOLUMBIA TOKYO

610 **BU** 0049
Printed in Japan