

DENON

Hi-Fi Integrated Stereo Amplifier

SERVICE MANUAL

MODEL PMA-350SE

INTEGRATED STEREO AMPLIFIER

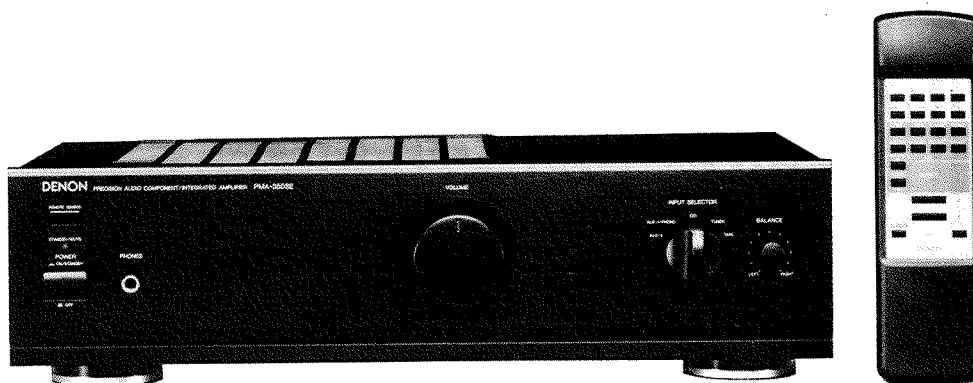

— TABLE OF CONTENTS —

OPERATING INSTRUCTIONS	2-7
REMOVAL OF EACH SECTION	8,9
REMOVAL FOR SERVICING	10
METHOD OF ADJUSTMENTS	11
BLOCK AND LEVEL DIAGRAM	12
SEMICONDUCTORS	13-15
PRINTED WIRING BOARD	16,17
NOTE FOR PARTS LIST	18
PARTS LIST OF P.W.BOARD	18,19
PARTS LIST OF EXPLODED VIEW	20
EXPLODED VIEW OF CHASSIS AND CABINET	21
WIRING DIAGRAM	22
SCHEMATIC DIAGRAM	23

• Some illustration using in this service manual is slightly different from the actual set.

NIPPON COLUMBIA CO., LTD.

CAUTION
RISK OF ELECTRIC SHOCK
DO NOT OPEN

CAUTION: TO REDUCE THE RISK OF ELECTRIC SHOCK, DO NOT REMOVE COVER (OR BACK). NO USER SERVICEABLE PARTS INSIDE. REFER SERVICING TO QUALIFIED SERVICE PERSONNEL.

The lightning flash with arrowhead symbol, within an equilateral triangle, is intended to alert the user to the presence of uninsulated "dangerous voltage" within the product's enclosure that may be of sufficient magnitude to constitute a risk of electric shock to persons.

The exclamation point within an equilateral triangle is intended to alert the user to the presence of important operating and maintenance (servicing) instructions in the literature accompanying the appliance.

WARNING: TO REDUCE THE RISK OF FIRE OR ELECTRIC SHOCK, DO NOT EXPOSE THIS APPLIANCE TO RAIN OR MOISTURE.

• FOR U.S.A & CANADA MODEL ONLY

CAUTION

TO PREVENT ELECTRIC SHOCK, DO NOT USE THIS (POLARIZED) PLUG WITH AN EXTENSION CORD, RECEPTACLE OR OTHER OUTLET UNLESS THE BLADES CAN BE FULLY INSERTED TO PREVENT BLADE EXPOSURE.

• POUR LE MODELE CANADIEN UNIQUEMENT

ATTENTION

POUR PREVENIR LES CHOCS ELECTRIQUES NE PAS UTILISER CETTE FICHE POLARISEE AVEC UN PROLONGATEUR, UNE PRISE DE COURANT OU UNE AUTRE SORTIE DE COURANT, SAUF SI LES LAMES PEUVENT ETRE INSEREES A FOND SANS EN LAISSER AUCUNE PARTIE A DECOUVERT.

• DECLARATION OF CONFORMITY

We declare under our sole responsibility that this product, to which this declaration relates, is in conformity with the following standards: EN60065, EN55013, EN55020, EN60555-2 and EN60555-3. Following the provisions of 73/23/EEC, 89/336/EEC and 93/68/EEC Directive.

• ÜBEREINSTIMMUNGSERKLÄRUNG

Wie erklären unter unserer Verantwortung, daß dieses Produkt, auf das sich diese Erklärung bezieht, den folgenden Standards entspricht: EN60065, EN55013, EN55020, EN60555-2 und EN60555-3. Entspricht den Verordnungen der Richtlinien 73/23/EEC, 89/336/EEC und 93/68/EEC.

• DECLARATION DE CONFORMITÉ

Nous déclarons sous notre seule responsabilité que l'appareil, auquel se réfère cette déclaration, est conforme aux standards suivants: EN60065, EN55013, EN55020, EN60555-2 et EN60555-3. D'après les dispositions des directives 73/23/EEC, 89/336/EEC et 93/68/EEC.

• DICHIARAZIONE DI CONFORMITÀ

Dichiaro con piena responsabilità che questo prodotto, al quale la nostra dichiarazione si riferisce, è conforme alle seguenti normative: EN60065, EN55013, EN55020, EN60555-2 e EN60555-3. In conformità con le condizioni delle direttive 73/23/EEC, 89/336/EEC e 93/68/EEC.

• DECLARACIÓN DE CONFORMIDAD

Declaramos bajo nuestra exclusiva responsabilidad que este producto al que hace referencia esta declaración, está conforme con los siguientes estándares: EN60065, EN55013, EN55020, EN60555-2 y EN60555-3. Conforme con las provisiones de las directivas 73/23/EEC, 89/336/EEC y 93/68/EEC.

• EENVORMIGHEIDSVERKLARING

Wij verklaren uitsluitend op onze verantwoordelijkheid dat dit product, waarop deze verklaring betrekking heeft, in overeenstemming is met de volgende normen: EN60065, EN55013, EN55020, EN60555-2 en EN60555-3. Volgens de bepalingen van de richtlijnen 73/23/EEC, 89/336/EEC en 93/68/EEC.

• ÖVERENSSTÄMMELSESINTYG

Härmed intygas helt på eget ansvar att denna produkt, vilken detta intyg avser, uppfyller följande standarder: EN60065, EN55013, EN55020, EN60555-2 och EN60555-3. Enligt stadgarna i direktiv 73/23/EEC, 89/336/EEC och 93/68/EEC.

• DECLARAÇÃO DE CONFORMIDADE

Declaramos sob nossa exclusiva responsabilidade que este produto, ao qual esta declaração corresponde, está em conformidade com as seguintes normas: EN60065, EN55013, EN55020, EN60555-2 e EN60555-3. De acordo com o estabelecido nas directivas 73/23/EEC, 89/336/EEC e 93/68/EEC.

SAFETY INSTRUCTIONS

1. Read Instructions - All the safety and operating instructions should be read before the appliance is operated.
2. Retain Instructions - The safety and operating instructions should be retained for future reference.
3. Heed Warnings - All warnings on the appliance and in the operating instructions should be adhered to.
4. Follow Instructions - All operating and use instructions should be followed.
5. Water and Moisture - The appliance should not be used near water - for example, near a bathtub, washbowl, kitchen sink, laundry tub, in a wet basement, or near a swimming pool, and the like.
6. Carts and Stands - The appliance should be used only with a cart or stand that is recommended by the manufacturer.
- 6A. An appliance and cart combination should be moved with care. Quick stops, excessive force, and uneven surfaces may cause the appliance and cart combination to overturn.
7. Wall or Ceiling Mounting - The appliance should be mounted to a wall or ceiling only as recommended by the manufacturer.
8. Ventilation - The appliance should be situated so that its location or position does not interfere with its proper ventilation. For example, the appliance should not be situated on a bed, sofa, rug, or similar surface that may block the ventilation openings; or, placed in a built-in installation, such as a bookcase or cabinet that may impede the flow of air through the ventilation openings.
9. Heat - The appliance should be situated away from heat sources such as radiators, heat registers, stoves, or other appliances (including amplifiers) that produce heat.
10. Power Sources - The appliance should be connected to a power supply only of the type described in the operating instructions or as marked on the appliance.
11. Grounding or Polarization - Precautions should be taken so that the grounding or polarization means of an appliance is not defeated.
12. Power-Cord Protection - Power-supply cords should be routed so that they are not likely to be walked on or pinched by items placed upon or against them, paying particular attention to cords at plugs, convenience receptacles, and the point where they exit from the appliance.
14. Cleaning - The appliance should be cleaned only as recommended by the manufacturer.
15. Power Lines - An outdoor antenna should be located away from power lines.
16. Outdoor Antenna Grounding - If an outside antenna is connected to the receiver, be sure the antenna system is grounded so as to provide some protection against voltage surges and built-up static charges. Article 810 of the National Electrical Code, ANSI/NFPA 70, provides information with regard to proper grounding of the mast and supporting structure, grounding of the lead-in wire to an antenna-discharge unit, size of grounding conductors, location of antenna-discharge unit, connection to grounding electrodes, and requirements for the grounding electrode. See Figure A.
17. Nonuse Periods - The power cord of the appliance should be unplugged from the outlet when left unused for a long period of time.
18. Object and Liquid Entry - Care should be taken so that objects do not fall and liquids are not spilled into the enclosure through openings.
19. Damage Requiring Service - The appliance should be serviced by qualified service personnel when:
 - A. The power-supply cord or the plug has been damaged; or
 - B. Objects have fallen, or liquid has been spilled into the appliance; or
 - C. The appliance has been exposed to rain; or
 - D. The appliance does not appear to operate normally or exhibits a marked change in performance; or
 - E. The appliance has been dropped, or the enclosure damaged.
20. Servicing - The user should not attempt to service the appliance beyond that described in the operating instructions. All other servicing should be referred to qualified service personnel.

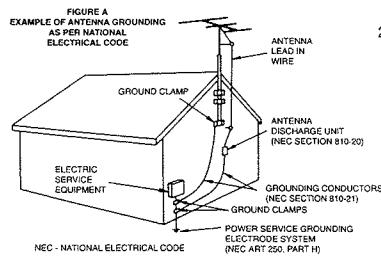

NOTE:

1. In order to turn the power on and off from the optional remote control handset (see page 11), keep the power switch on the amplifier on.
2. Switch off the amplifier and unplug the power cord when you do not plan to use the unit for a long period of time.
3. When installing the unit, leave at least 10 cm distance on the left and right and on the rear of the unit as well as 10 cm to any other component placed above.

CAUTION:
 If only the MUTE/STANDBY LED is lit, this means that the power is turned off from the remote control unit. Turn the power on from the remote control unit.

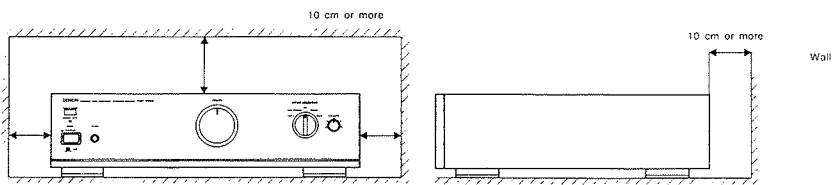

NOTE ON USE

<p style="font-size: x-small;">• Avoid high temperatures. Allow for sufficient heat dispersion when installed on a rack.</p>	<p style="font-size: x-small;">• Keep the set free from moisture, water and dust.</p>	<p style="font-size: x-small;">• Do not let foreign objects in the set.</p>
<p style="font-size: x-small;">• Handle the power cord carefully. Hold the plug when unplugging the cord.</p>	<p style="font-size: x-small;">• Unplug the power cord when not using the set for long periods of time.</p>	<p style="font-size: x-small;">• Do not let insecticides, benzene, and thinner come in contact with the set.</p>
<p style="font-size: x-small;">*(For sets with ventilation holes) • Do not obstruct the ventilation holes.</p>	<p style="font-size: x-small;">• Never disassemble or modify the set in any way.</p>	

— TABLE OF CONTENTS —

1	DESIGNATIONS AND FUNCTIONS OF PANEL CONTROLS (1).....	6
2	CONNECTIONS.....	7
3	DESIGNATIONS AND FUNCTIONS OF PANEL CONTROLS (2).....	8
4	OPERATION.....	9
5	REMOTE CONTROL OPERATION.....	10
6	TROUBLESHOOTING.....	12
7	SPECIFICATIONS.....	13

Please check to make sure the following items are included with the main unit in the carton:

- (1) Operating instructions..... 1

1 DESIGNATIONS AND FUNCTIONS OF PANEL CONTROLS (1)

FRONT PANEL

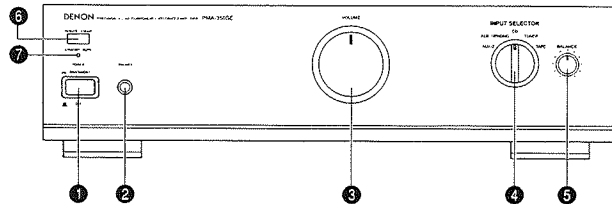

REAR PANEL

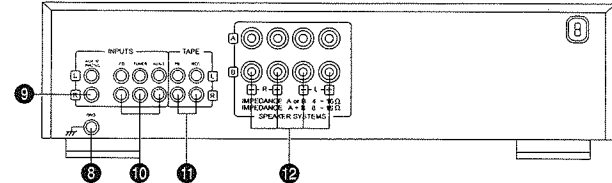

8 GND	9 AUX-1/PHONO (see page 8)	10 CD, TUNER, AUX-2	11 TAPE PB, TAPE REC	12 SPEAKERS
GND for PHONO	Input terminals (AUX-1/PHONO) If you want to use these terminals for PHONO connection, you will need the optional PHONO CARD. For more information on the PHONO CARD, please contact your dealer or your DENON Service Center.	Input Terminals (CD, TUNER, AUX-2)	Playback and Recording Terminals • Playback Terminals • Recording Terminals	Speaker Terminals

6

2 CONNECTIONS

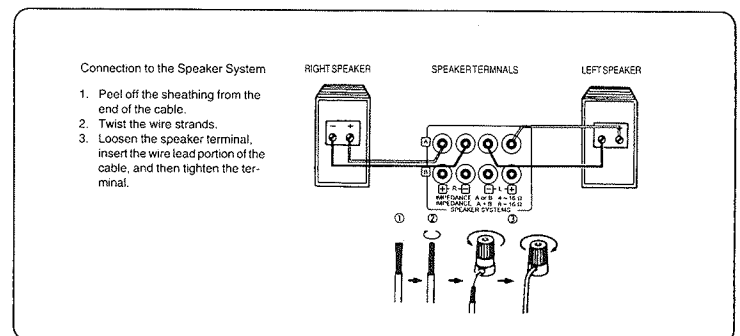
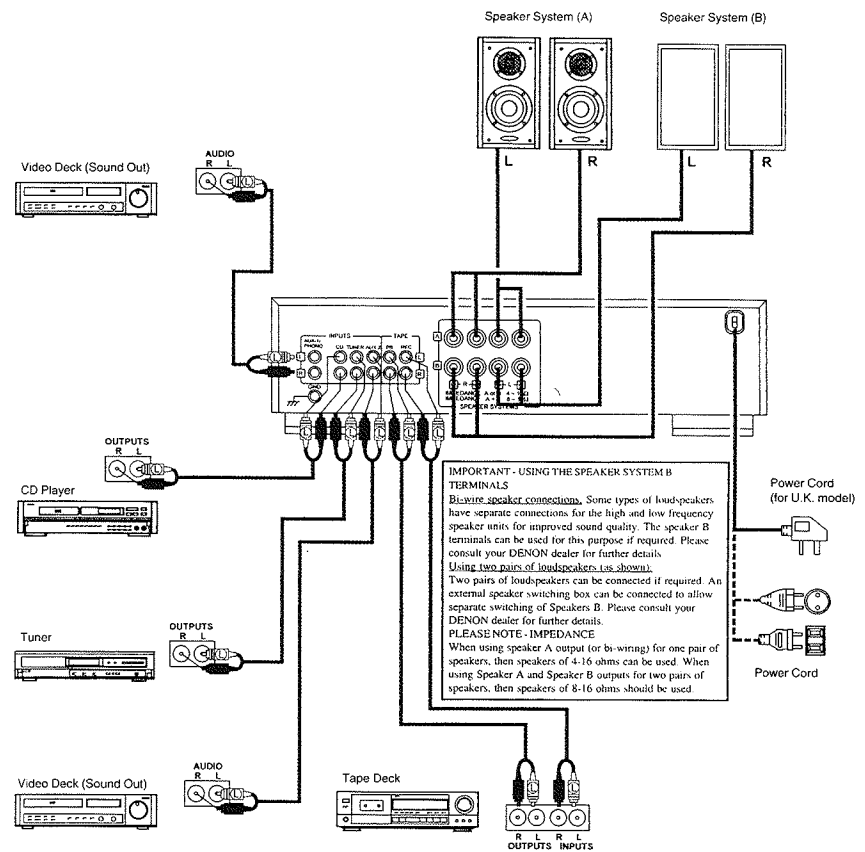

7

3 DESIGNATIONS AND FUNCTIONS OF PANEL CONTROLS (2) (SEE PAGE 6)

1 POWER (Power Switch)

When the power switch is turned ON (I), the MUTE/STANDBY LED (7) lights.

When the power switch is turned ON, power is supplied to the unit. It takes a few seconds after the power is turned on for the unit to warm up. This is due to the built-in muting circuit that eliminates noise during the on/off operation.

2 PHONES (Headphone Jack)

This jack is used to plug in the headphones.

3 VOLUME (Volume Control)

This knob controls the overall volume level. Turn the knob clockwise (↻) to raise the volume and counterclockwise (↺) to lower it.

4 INPUT SELECTOR (Input Select Switch)

This switch is used to select the input signal for the program source. The source to be recorded is also selected with the switch.

- AUX-1/PHONO: This is the AUX-1 jack. If you want to use the terminal for PHONO connection, you will need the optional PHONO CARD.
- CD: Use this position when using the CD player, etc., connected to the CD jacks.
- TUNER: Use this position when using the tuner, etc., connected to the TUNER jacks.
- AUX-2: Use this position when using the component connected to the AUX-2 jacks.
- TAPE: Use this position, when using a tape deck connected to the TAPE jacks.

5 BALANCE (Balance Control)

This knob is used to adjust the balance between the left and right channels. When it is set to the center position, the amplitude of the amplifier is equal on both sides. If there is a difference in the left and right channel output voltages for a cartridge, move the knob to the left and the right to adjust it. If the volume on the right side is too low, turn the knob clockwise (↻). If the volume on the left side is too low, turn the knob counterclockwise (↺). This will achieve an even balance on the left and right sides.

6 REMOTE SENSOR (Remote Control Sensor)

This sensor receives the infra-red light transmitted from the wireless remote control unit. For remote control, point the wireless remote control unit towards the sensor.

7 MUTE/STANDBY LED

This LED shows following condition of this set.

- Lighting (red): Power on
- Lighting (orange): Standby mode
- Flashing every a second: Muting of audio signal (no sound)
- Flashing every half second: Protection circuit is activated
- Lighting out: Power off

8

4 OPERATION

PREPARATION

1. CHECKING CONNECTIONS

- Make sure that all the connections are proper by referring to the back panel (see page 7).
- Check the polarity (positive and negative) of the speaker connections, and the directivity of stereo separation (right cord to right channel terminal, and left cord to left channel terminal).
- Check the directivity of pin cord connection.

2. SETTING OF EACH KNOB

- Turn the volume control knob (3) counterclockwise, to the end.
 - Set the balance control to "center position".
- After checking the above items, turn on the power, the amplifier is set in the ready mode in a few seconds.

PLAYBACK OF CD PLAYER

1. Set the INPUT SELECTOR switch (4) to "CD".
2. Operate the CD player.
3. Turn the volume to yield an appropriate volume and balance control.

RECEPTION OF RADIO PROGRAMS

1. Set the INPUT SELECTOR switch (4) to "TUNER".
2. Operate the tuner to receive a radio program.
3. Turn the volume to yield an appropriate volume and balance control.

CONNECTIONS OF AUDIO EQUIPMENT TO AUX-1/PHONO TERMINALS (see Warning)

1. Set the INPUT SELECTOR switch (4) to "AUX-1/PHONO" Position.
2. Operate the Audio equipment Systems.
3. Turn the volume to yield an appropriate volume and balance control.

CONNECTIONS OF AUDIO EQUIPMENT TO AUX-2 TERMINALS

1. Set the INPUT SELECTOR switch (4) to "AUX-2" Position.
2. Operate the Audio equipment Systems.
3. Turn the volume and tone controls to yield an appropriate volume and balance control.

PLAYBACK WITH TAPE DECK

1. Set the INPUT SELECTOR switch (4) to "TAPE".
2. Operate the Tape Deck.
3. Turn the volume to yield an appropriate volume and balance control.

RECORDING WITH TAPE DECK

The source to be recorded is selected by the INPUT SELECTOR switch (4).

PLAYING A RECORD (with optional Phono card fitted) (see Warning)

1. Set the INPUT SELECTOR switch (4) to "AUX-1/PHONO".
2. Operate the turntable and play record.
3. Turn the volume to yield an appropriate volume and balance control.

CAUTION

Protective Circuit

This set is equipped with a high speed protective circuit. This circuit protects the internal circuitry from damage due to large currents flowing when the speaker jacks are not completely connected or when an output is generated by a short circuit. This protective circuit's operation cuts off the output to the speakers. In such a case, be sure to turn the power to the set off and check the connections to the speakers. Then turn the power on again. After muting for a few seconds, the set will operate normally.

Warning

* This amplifier does not incorporate a Phono Equalization stage as standard. Therefore, if a turntable is to be used with this product, it is essential to fit the Optional Phono Card to the AUX-1/PHONO input. Please consult your authorized dealer for further details.
** When this amplifier is fitted with the Optional Phono Card, the AUX-1 input becomes inoperable. Any attempt to connect equipment other than a turntable will result in a damage to your system.

5 REMOTE CONTROL OPERATION (OPTIONAL)

The optional Remote Control Unit can be used to control the amplifier from a convenient distance. Please consult your authorized dealer for further details.

(1) Inserting the dry cell batteries

1. Remove the battery cover on the back of the Remote Control Unit.

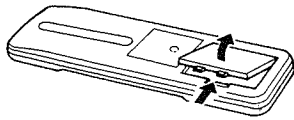

2. Insert two dry cell batteries as shown in the diagram on the battery supply unit.

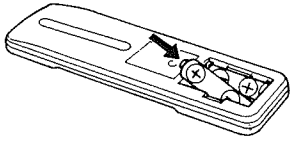

3. Replace the battery cover.

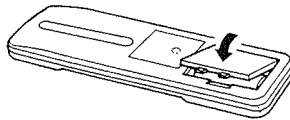

(2) Directions for Use

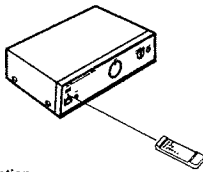

Notes on Use of the Battery Usage

- RC-819 uses size R6P (AA) dry cell batteries.
- The batteries will need to be replaced approximately once a year. This will depend upon how often the remote control unit is used.
- If, in less than a year from the time new batteries were inserted, the Remote Control Unit fails to operate the Amplifier from a near-by position, it is time to replace the batteries.
- Insert the batteries properly, following the polarity diagram in the battery compartment.
- Batteries are prone to damage and leakage. Therefore:
 - Do not mix new batteries with used ones.
 - Do not mix different types of batteries.
 - Do not jumper the opposite poles of the batteries, expose them to heat or break them open, nor expose them to open fire.
- If the batteries have leaked, remove any traces of battery fluid from the inside of the battery compartment by wiping thoroughly with a dry cloth. Then insert new batteries.

- Operate the Remote Control Unit while pointing it towards the Remote Control Sensor on the Amplifier as shown in the diagram on the left.
- The Remote Control Unit can be used at a distance up to about 8 meters in a straight line from the amplifier. This distance will decrease if there are obstructions blocking the infra-red light transmission or if the Remote Control Unit is not directed straight at the amplifier.

Note on Operation

- Do not press the operating buttons on the Amplifier and the remote control unit at the same time. This will cause misoperation.
- Operation of the remote control unit will become less effective or erratic if the infrared Remote Control Sensor on the Amplifier is exposed to strong light or if there are obstructions between the Remote Control Unit and the sensor.
- In case you operate your VCR, TV or other components by remote control, do not operate buttons on two different remote control units at the same time. This will cause misoperation.

Besides being able to operate the PMA-350SE amplifier with this Remote Control Unit, you can also operate a DENON cassette deck and CD player from this handy full-system Remote Control Unit.

Remote Control Unit

The full-system remote control unit operates the major functions of the Amplifier such as volume. But that's not all! The same control pad can also control the major functions of a DENON CD player, cassette deck and tuner when combined with the PMA-350SE to create a remarkably ergonomic and versatile DENON system with all the quality sound reproduction that the devoted audiophile expects.

Remote Control Unit RC-819 (optional for the PMA-350SE)

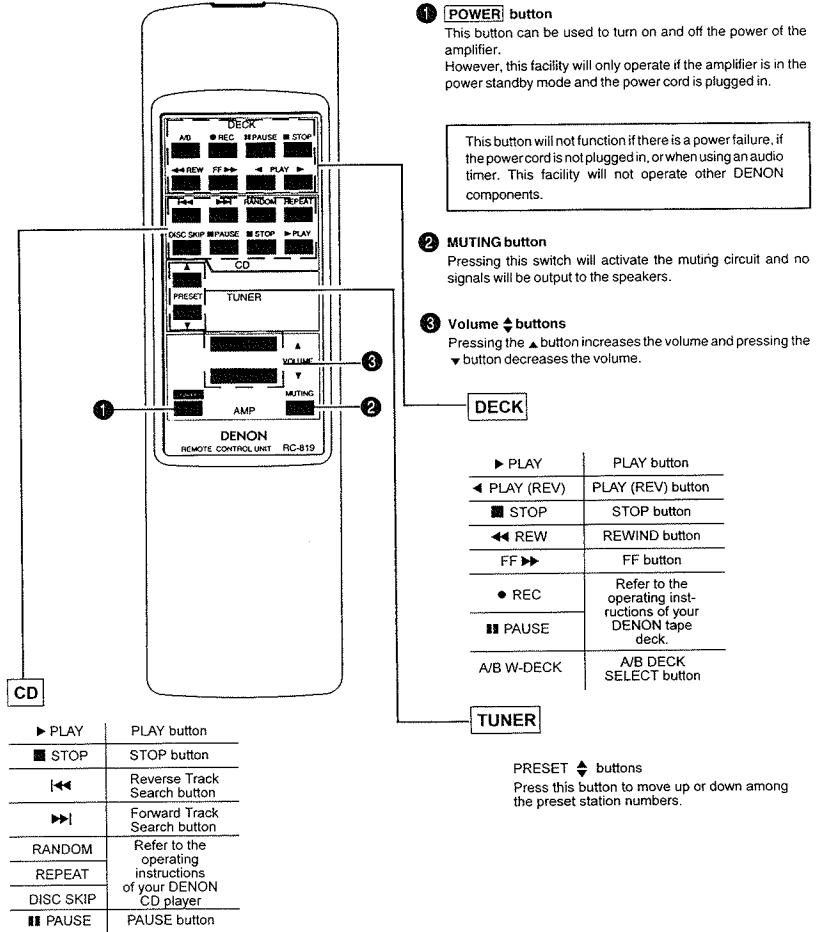

- The RC-819 Remote Control Unit can control CD players and cassette decks manufactured by DENON.
- Note that operation may not be possible for some models.
- Buttons are conveniently separated into groups, each group controlling one specific component. The groups are AMP, CD, DECK and TUNER etc.

For details on operating other components, refer to the operating instructions for the CD player and/or cassette deck.

CAUTION:

- If the power is turned off with the remote Control Unit, the set is switched to the power stand-by state. If you are absent for a long period of time, unplug the power cord.
- Only the MUTE/STANDBY LED lights (orange) when in the power stand-by mode.
- You may experience erratic operation of the Remote Control Unit if it is operated in fluorescent light and direct sunlight, in particular if this light strikes the Remote Control Sensor on the Amplifier. However, this is not a malfunction, and if this should happen, simply protect the sensor against such light.

6 TROUBLESHOOTING

Check the following before assuming there is a problem with the set.

1. Are all connections proper?
2. Is the set being operated as described in the operating instructions?
3. Are the speakers and input components being operated properly?

If the set does not seem to be operating properly, check the points listed below. If these points do not apply, the set may be damaged. Turn off the power immediately and contact your store of purchase.

Symptom	Cause	Measures	Page	
Common problems existing when listening to the CD, records, tapes, and FM broadcasts	MUTE/STANDBY LED does not light and no sound is produced when POWER switch is turned on.	• Power cord is not connected.	• Check that the cord is plugged in.	7
	MUTE/STANDBY LED lights but no sound is produced.	• Speaker cords not properly connected. • INPUT SELECTOR not set to proper position. • VOLUME control turned down.	• Connect securely. • Set to the proper position. • Set to an appropriate level.	7 8 8
	Sound is not produced from one side only.	• Speaker cords not properly connected. • Input cords not properly connected. • Left and right balance improperly adjusted.	• Connect securely. • Connect securely. • Adjust the BALANCE control.	7 7 8
	Volume level is different when listening to tuner and records. ¹⁾	• Tuner and record outputs different.	• Adjust the tuner output to the turntable's output (if the tuner is equipped with an output control).###	8
	Positions of instruments inverted for stereo sources.	• Left and right speakers or input cords inverted.	• Check the left/right connections.	7
Problems occurring when playing records	Booming sound produced when playing records. ¹⁾	• Turntable's ground wire not connected. • Input cords not properly connected to AUX-1/PHONO terminals. • Influence from a TV or VCR near the turntable.	• Connect securely. • Connect securely. • Change the position of installation.	7 7 -
	Howling produced when volume is turned up while playing records. ¹⁾	• Turntable and speaker systems are too close. • Floor is soft and vibrates easily.	• Move speaker systems as far as possible. • Use cushions to absorb the vibrations transmitted from the floor to the speakers. If the turntable does not include insulators, use audio insulators available in stores.	- -
	Sound is distorted. ¹⁾	• Stylus pressure is too light. • Dirt on tip of stylus. • Defective cartridge.	• Apply proper pressure. • Check the tip of the stylus. • Replace the cartridge.	- - -
Remote control unit	This unit does not operate properly when remote control unit is used. ²⁾	• Batteries dead. • Remote control unit is too far from this unit. • Obstacle between this unit and remote control unit. • Different button is being pressed. • ◀ and ▶ ends of battery inserted in reverse.	• Replace with new batteries. • Move closer. • Remove obstacle. • Press the proper button. • Insert batteries properly.	10 10 10 11 10

¹⁾ with optional Phono Card fitted.

²⁾ with optional remote control unit RC-819 used

7 SPECIFICATIONS

Technical Data (typical value)

POWER AMPLIFIER SECTION

Rated Output Power:	
Both channels driven (8Ω/ohms Load)	50 W + 50 W
20 Hz to 20 kHz, T.H.D. 0.7% (4Ω/ohms Load)	80 W + 80 W
DIN, 1 kHz, T.H.D. 0.7%	
Total Harmonic Distortion: (-3 dB at rated output, 8Ω/ohms)	0.05 %

PRE AMPLIFIER SECTION

Rated Output: (Recout Terminal)	150 mV
Input Sensitivity/ Input Impedance: CD, TUNER, AUX-1/2, TAPE	150 mV / 47 kΩ

OVERALL CHARACTERISTICS

S/N Ratio (IHF A Network): (Input terminals short-circuited)	CD, TUNER, AUX-1/2, TAPE: 98 dB
--	---------------------------------

OTHERS

Power Supply	AC 230 V / 50 Hz (for Europe and Australia)
Power Consumption	160 W
Dimensions (W) x (H) x (D)	434 (W) x 120 (H) x 286 (D) mm (17-3/21" x 4-22/32" x 11-3/32")
Net Weight	6.2 kg (13 lbz 11 oz)

REMOTE CONTROL UNIT RC-819 (optional)

Remote control system:	Infrared pulse system
Power supply:	3V DC, two size R6P ("AA") dry cell batteries

- Specifications and contents are subject to change without notice for purposes of improvement.

REMOVAL OF EACH SECTION

1. Top Cover

- 1) Remove 4 screws (A) and 3 screws (B).
- 2) Pull up the Top Cover in arrow direction.

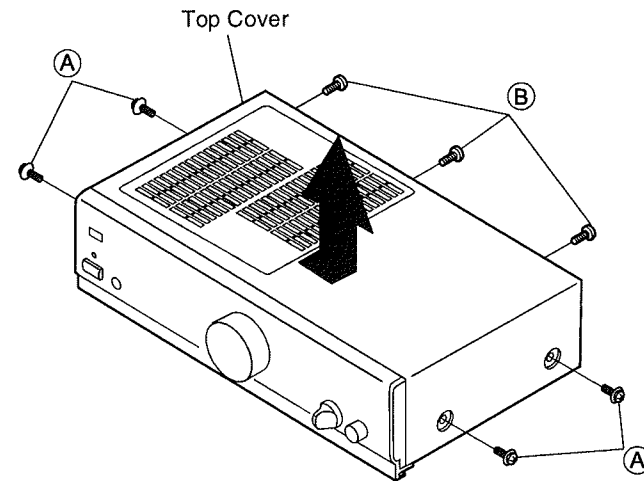

2. Front Panel

- 1) Remove 3 screws (C).
- 2) Remove 1 screw (K).
- 3) Remove 3 screws (D).
- 4) Detach the Front Panel in arrow direction.

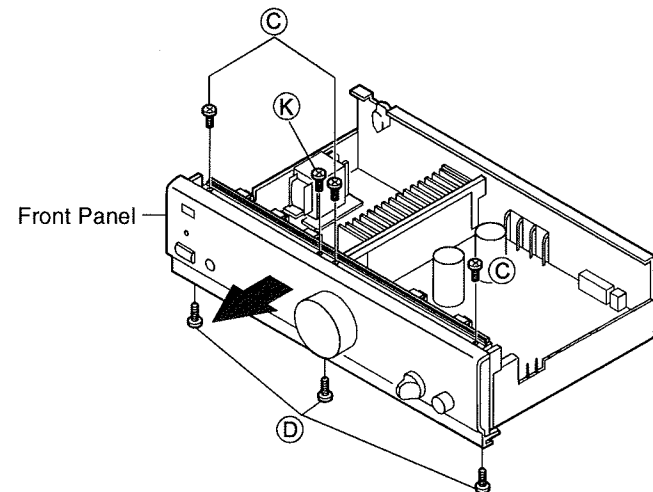

3. Main Chassis

- 1) Remove 2 screws (E).
- 2) Remove 2 screws (F) securing the Power Radiator with the Main Chassis.
- 3) Remove 6 screws (G) securing the Rear Panel with the Main Chassis.

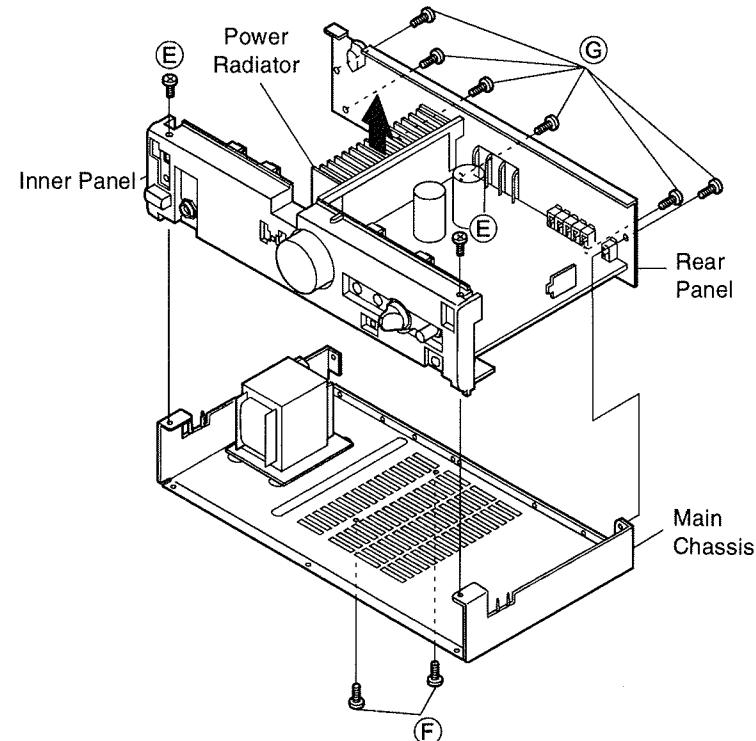

4. Inner Panel

- 1) Remove 3 Knobs and 4 nuts.
- 2) Detach the Inner Panel in arrow direction.

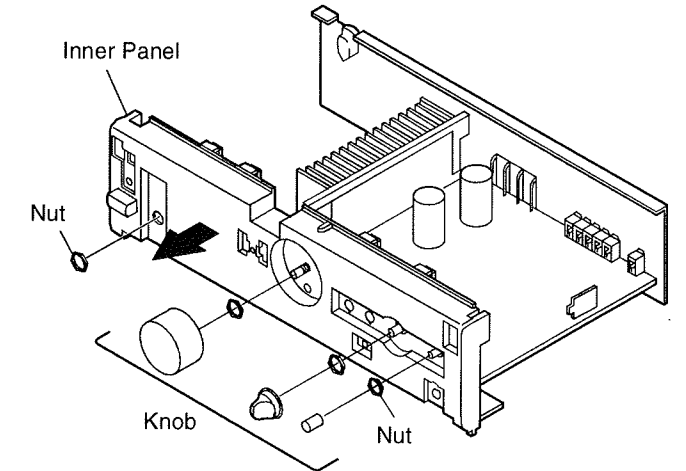

5. Each Unit of Inner Panel

- 1) Remove 2 screws (H), and detach the Control Unit.
- 2) Remove 2 screws (I), and detach the Power Switch and Head phone Unit.

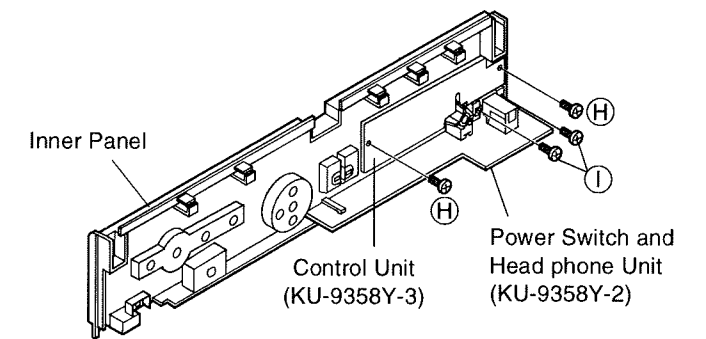

REMOVAL FOR SERVICING

1. Remove the Top Cover and the Front Panel.
(Please refer to the remove of each section.)
2. Remove 2 screws **(A)** on the bottom.

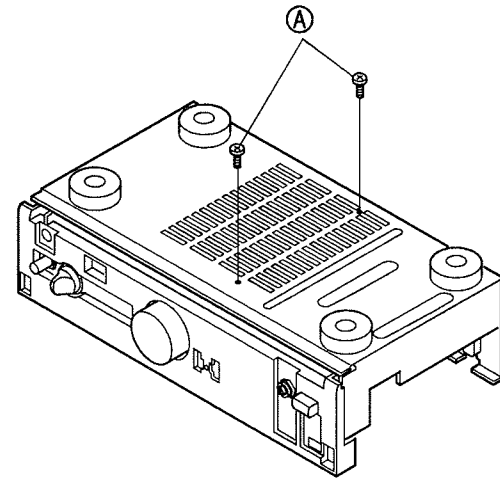

3. Remove 2 screws **(B)** fixing the Inner panel, and 6 screws **(C)** securing the Rear Panel.

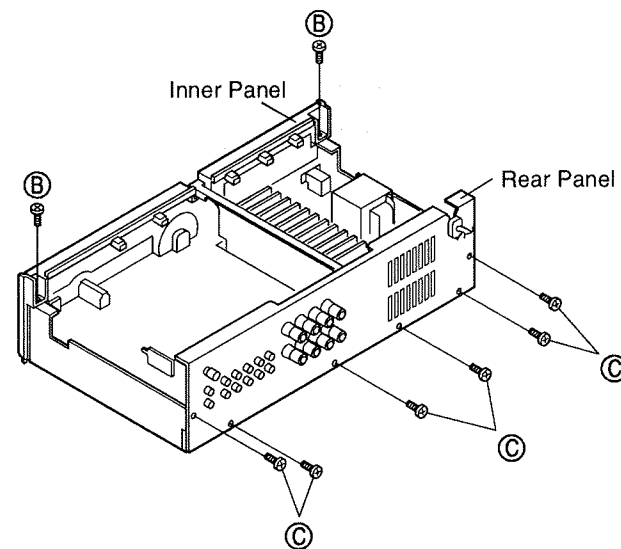

4. Pull out the Rear Panel, and the Power Radiator together, and the Main Chassis as shown in the figure for servicing.
5. When completed service, please assemble with reverse process.

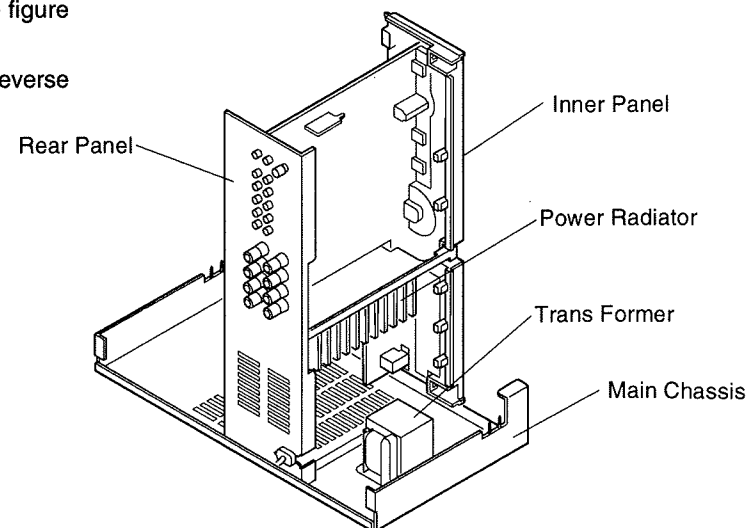

METHOD OF ADJUSTMENTS

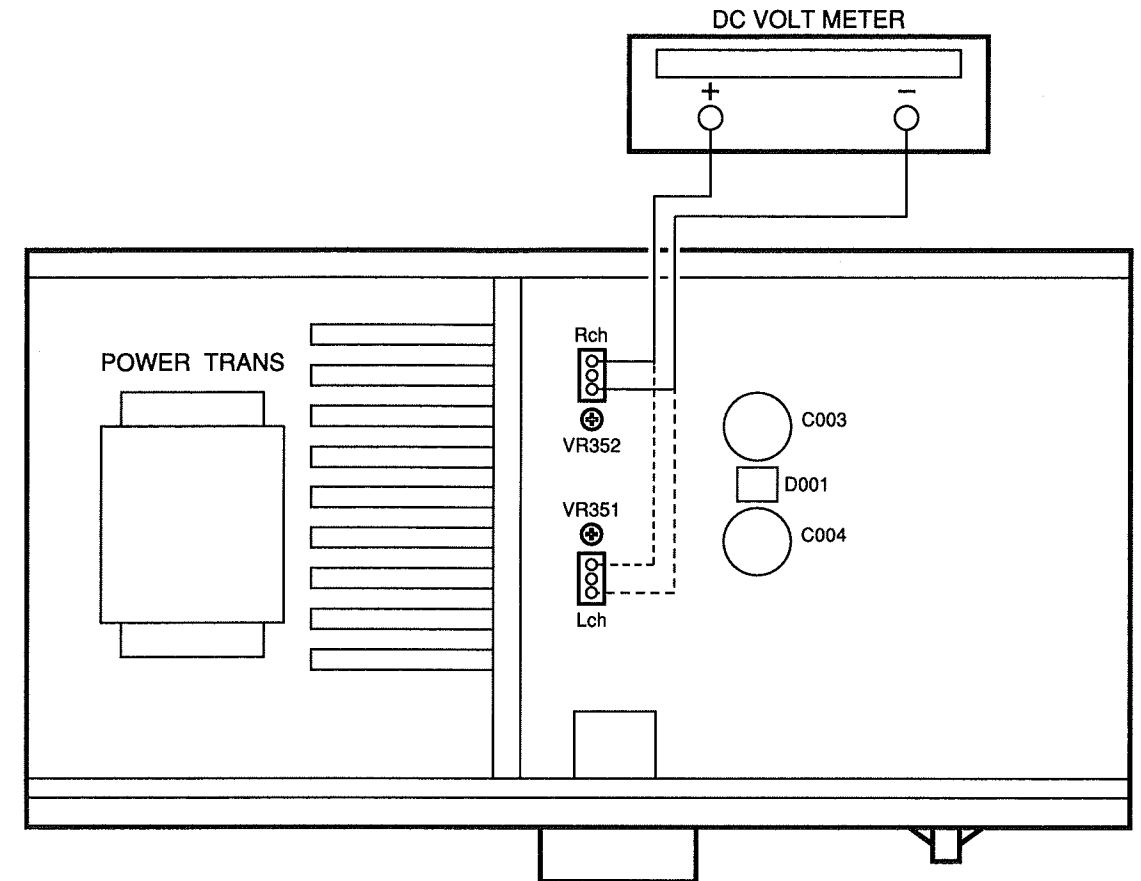

IDLING CURRENT

● Setup

1. Lay the unit at an ordinary position away from a direct current from an air condition or fan. Do the adjustment at a temperature between 15°C (59°F) and 30°C (86°F).
2. Set controls as follows.

POWER SWITCH	→ OFF (■)
VOLUME CONTROL	→ fully counterclockwise. (⤵) min. [Main volume (VR751) and Semifixed volume (VR351...Lch, VR352...Rch).]
SPEAKER Terminals	→ Open: do not connect the speakers, dummy load etc.

● Adjustment

1. Remove Top cover. And then connect DC Voltmeter to Test points of KU-9358-1 Printed Wiring Board (Main Unit).
2. Connect Power cord to AC wall outlet, and turn Power Switch "ON" (■). Within 10 seconds turn VR351 (Lch) and VR352 (Rch) clockwise so that the DC Voltmeter reads 10 ± 0.5 mV DC.
3. Then after 2 minutes warmup adjust VR351 and VR352 so that the DC Voltmeter reads 10 ± 0.5 mV DC.
4. And after 10 minutes warmup adjust VR351 and VR352 so that the DC Voltmeter reads 10 ± 0.5 mV DC.

BLOCK AND LEVEL DIAGRAM

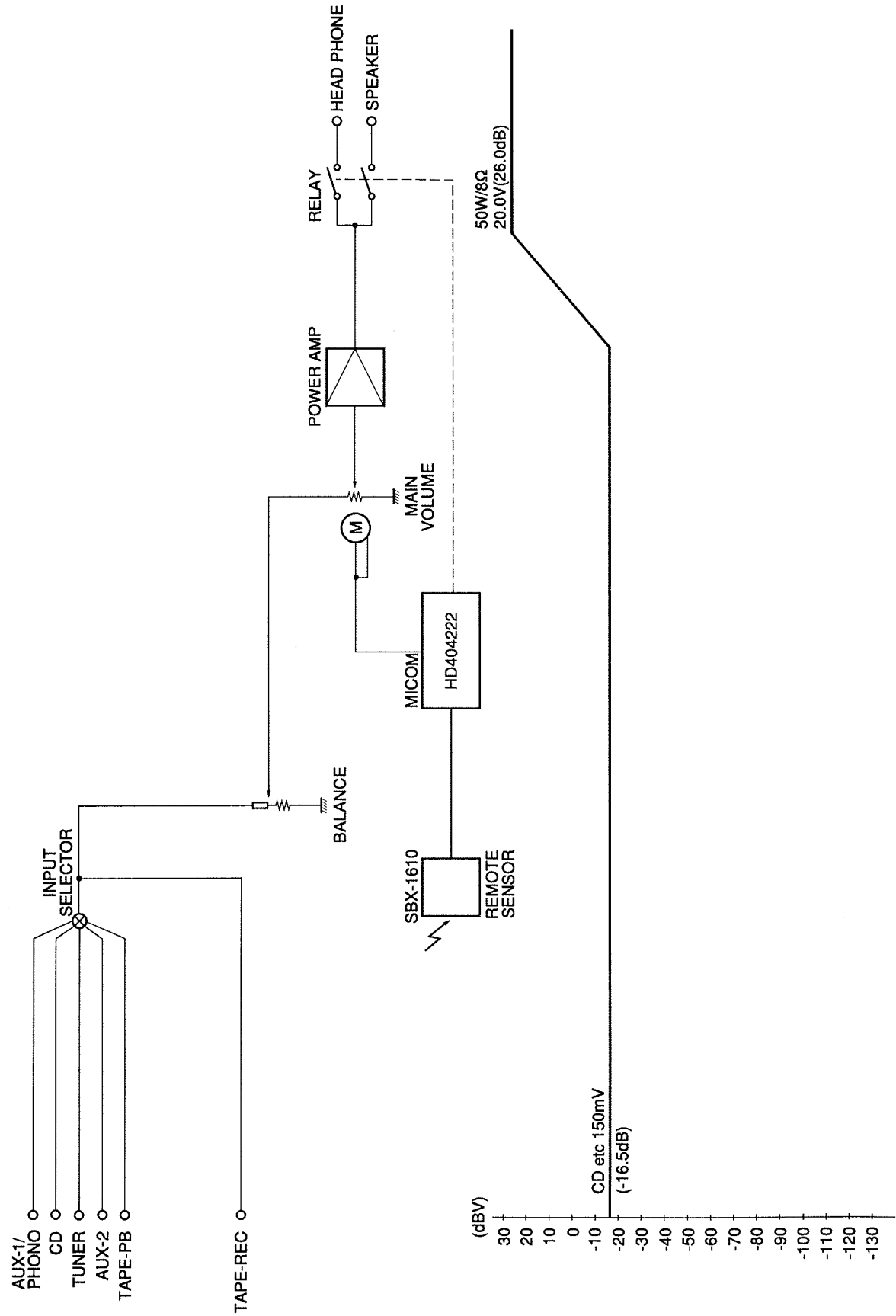

SEMICONDUCTORS

● IC's

HD404222 (IC601)

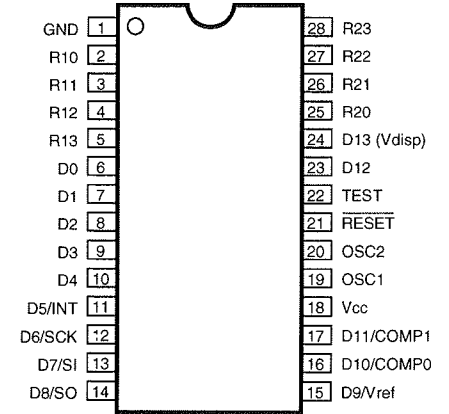
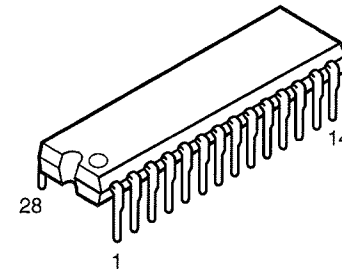

HD404222 Terminal Function

Pin No.	Symbol	Typ	Opt	I/O	Res	Ini	Act	Det	Function
1	GND	—	—	—	—	—	—	—	Ground.
2	NC	B	IU	O	HZ	L	—	—	Connect to ground.
3	NC	B	IU	O	HZ	L	—	—	Connect to ground.
4	NC	B	IU	O	HZ	L	—	—	Connect to ground.
5	NC	B	IU	O	HZ	L	—	—	Connect to ground.
6	VOLUME UP	B	IU	O	HZ	L	H	—	Volume drive output.
7	VOLUME DOWN	B	IU	O	HZ	L	H	—	Volume drive output.
8	NC	B	IU	I	HZ	L	—	—	Connect to ground.
9	B-DOWN	B	IU	I	HZ	H	L	Lv	Power supply stop detection input.
10	PROTECTION	B	IU	I	HZ	H	L	Lv	Protecting detection input.
11	REMOCON	B	IU	I	HZ	H	L	Ed	Remote control signal input.
12	NC	B	IU	O	HZ	L	—	—	Connect to ground.
13	NC	B	IU	O	HZ	L	—	—	Connect to ground.
14	NC	B	IU	O	HZ	L	—	—	Connect to ground.
15	VREF	—	—	—	—	—	—	—	Reference voltage input for comparator.
16	NC	B	IU	I	HZ	L	—	Alg	Connect to ground.
17	NC	B	IU	I	HZ	L	—	—	Connect to ground.
18	Vcc	—	—	—	—	—	—	—	Power supply.
19	OSC1	—	—	I	—	—	—	—	Xtal input.
20	OSC2	—	—	O	—	—	—	—	Xtal output.
21	RESET	—	EU	I	L	H	H	—	Reset signal input.
22	NC	—	—	I	—	—	—	—	Connect to ground.
23	POWER ON/OFF	B	IU	O	HZ	H	L	—	Power ON/OFF shift output (L: Power ON).
24	MUTING	B	IU	O	HZ	H	H	—	Mute signal output (H: Mute ON).
25	NC	B	IU	O	HZ	L	—	—	Connect to ground.
26	MUTE/STANDBY	B	IU	O	HZ	H	L	—	LED drive output for Mute/Standby indication.
27	NC	B	IU	O	HZ	H	—	—	Connect to ground.
28	NC	B	IU	O	HZ	H	—	—	Connect to ground.

Note:

- Typ (Type) : B=NMOS open drain.
- Opt (Option) : IU=internal pull up, EU=external pull up.
- Port state : Res=reset, Ini=standby, Act=active.
- Det : Lv=level, Ed=edge, Alg=analog.
- I/O : Port input / output for defined name (I: Input, O: Output).
- Res : Show port state at reset (H: High level, L: Low level, HZ: High impedance).
- Opt : ★U: Pull up, ★D: Pull down.
- Det : Show operating condition of input port (Lv: Detect level, Ed: Detect edge).
- Ini : Show input / output port initialization (H: High level, L: Low level).
- Act : Show port state at operating.

BA6208S (IC751)

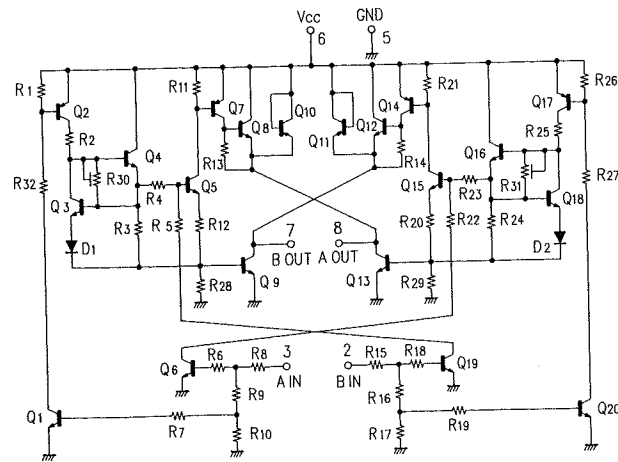
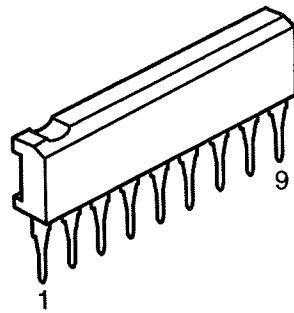

IC PROTECTOR

NJM5532DD (IC302)

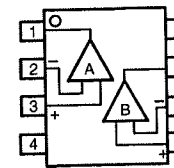
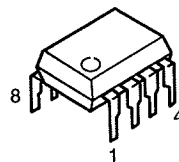

- 1: A Output
- 2: A- Input
- 3: A+ Input
- 4: V-
- 5: B+ Input
- 6: B- Input
- 7: B Output
- 8: V+

NJM7806FA (IC752)

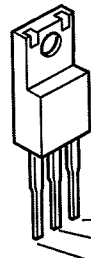

- 1: Output
- 2: GND
- 3: Input

ICP-N10 (IP401, 402)



TRANSISTORS

2SA988(E/F)
2SC1815(Y)
2SC1841(E/F)

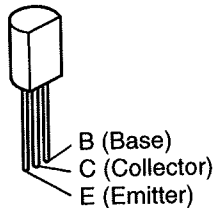

2SB1560 (TR363,364)
2SD2390 (TR361,362)

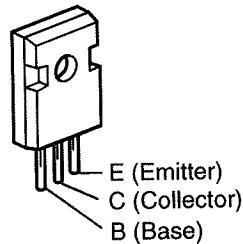

2SA933AS(R)
2SC1740S(R)

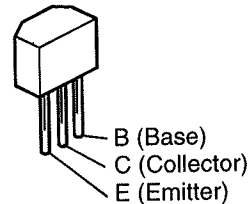

2SB1655E
2SD2396K

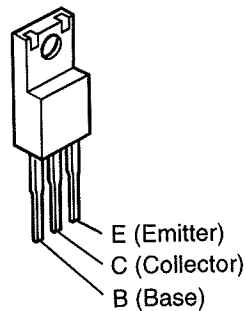

DTA114ES
DTC114ES
DTC123JS
DTC143XS

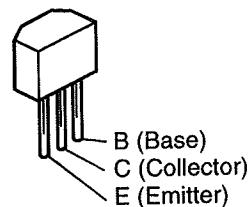

PNP Type

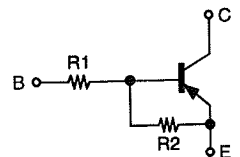

	R1	R2
DTA114ES	10kohm	10kohm

NPN Type

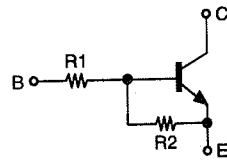

	R1	R2
DTC114ES	10kohm	10kohm
DTC123JS	2.2kohm	47kohm
DTC143XS	4.7kohm	10kohm

DIODES

1SS252

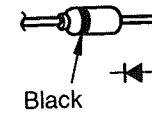

1SR35-200A

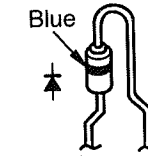

MTZJ3.3A
MTZJ3.0A
MTZJ7.5C

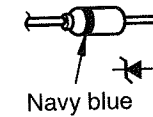

S4VB20F (D001)

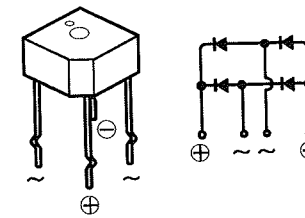

SF0R1A42 (Thyristor)
(SC401)

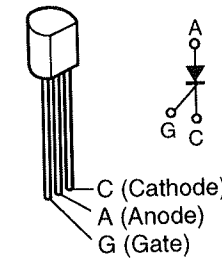

POSISTOR

PTH9M04BD222TS2F333 (P752)



LED

SML16751WN (LE751)

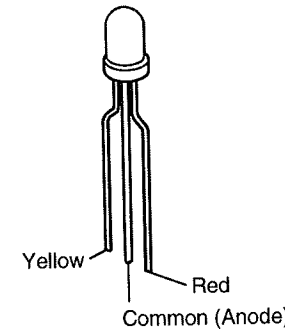

OTHER

SBX1610-52 (Remote Control Receiver)
(RM651)

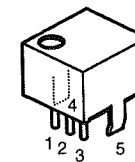

- 1. Vcc
- 2. Output
- 3. GND
- 4. Case Fin
- 5. Case Fin

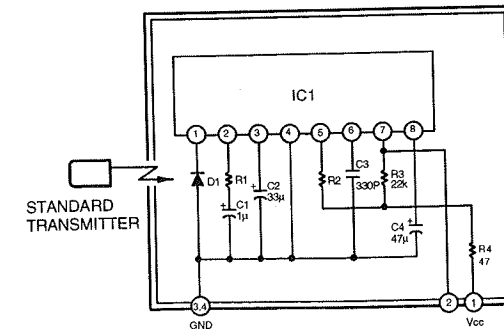

- IC1 : CX20106A Chip
- D1 : PIN Photodiode Chip
- C1, C2, C4 : Aluminum Electrolytic Capacitor
- C3 : SL Characteristic ±5%
- R1 : Gain control resistor
- R2 : fo control resistor (Using ±1%)
- R (Other than above items) : ±5%

PRINTED WIRING BOARD (Pattern Side)

1

2

3

4

5

6

7

8

KU-9358Y MAIN P.W.B. UNIT ASS'Y

A

B

C

D

E

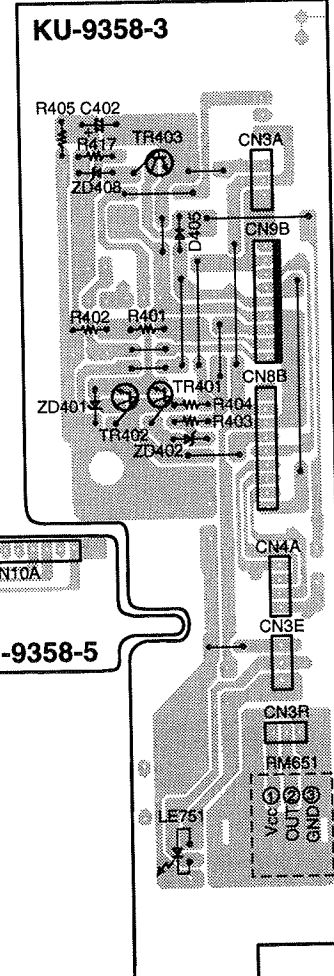
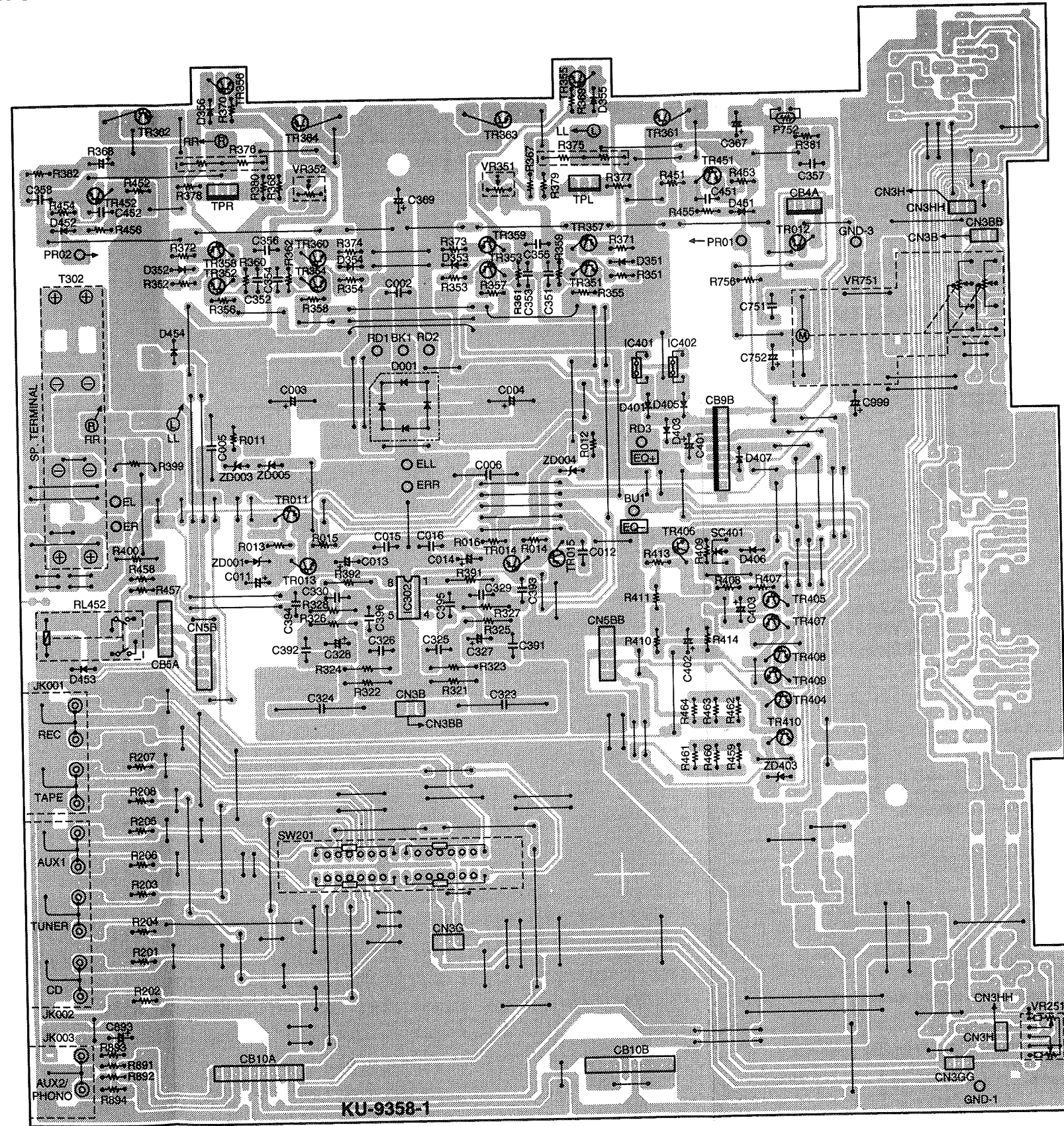

1 2 3 4 5 6 7 8

KU-9356Y CONTROL P.W.B. UNIT ASS'Y

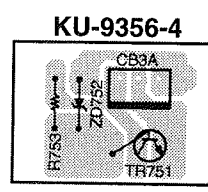
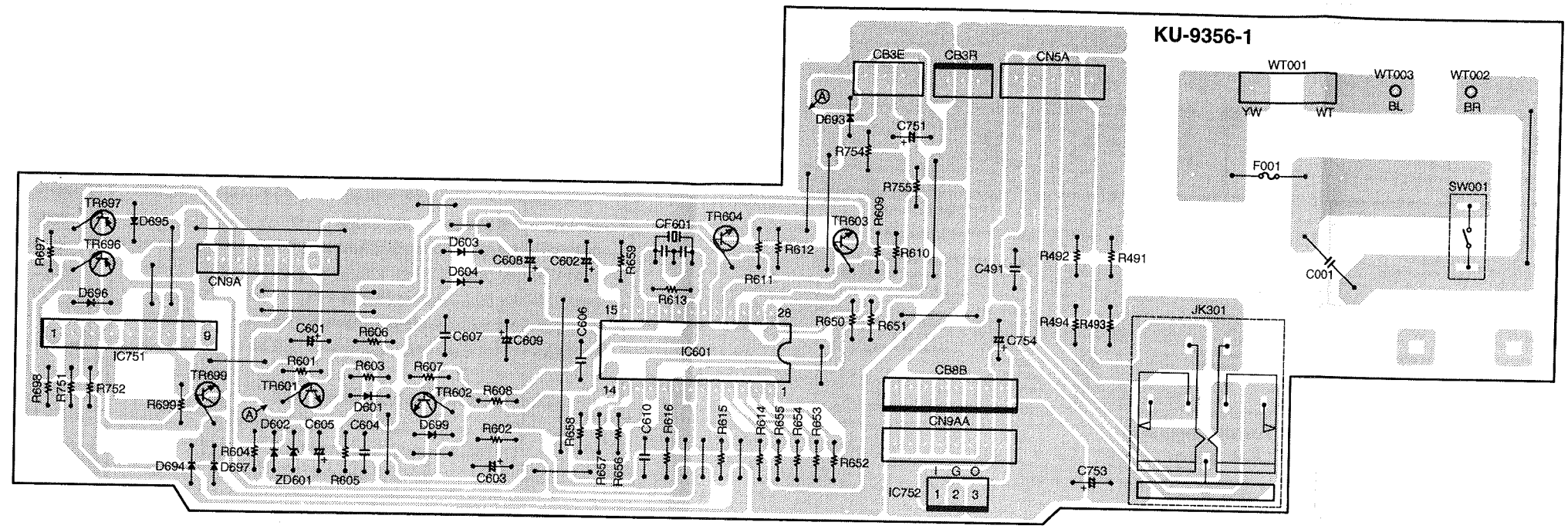

A
B
C
D
E

NOTE FOR PARTS LIST

- Part indicated with the mark "⊙" are not always in stock and possibly to take a long period of time for supplying, or in some case supplying of part may be refused.
 - When ordering of part, clearly indicate "1" and "1" (i) to avoid mis-supplying.
 - Ordering part without stating its part number can not be supplied.
 - Part indicated with the mark "★" is not illustrated in the exploded view.
 - Not including Carbon Film ±5%, 1/4W Type in the P.W.Board parts list. (Refer to the Schematic Diagram for those parts.)
- WARNING:**
Parts marked with this symbol  have critical characteristics.
Use ONLY replacement parts recommended by the manufacturer.

● Resistors

Ex.: **RN** **14K** **2E** **182** **G** **FR**
 Type Shape and performance Power Resistance Allowable error Others

RD : Carbon	2B : 1/8W	F : ±1%	P : Pulse-resistant type
RC : Composition	2E : 1/4W	G : ±2%	NL : Low noise type
RS : Metal oxide film	2H : 1/2W	J : ±5%	NB : Non-burning type
RW : Winding	3A : 1W	K : ±10%	FR : Fuse-resistor
RN : Metal film	3D : 2W	M : ±20%	F : Lead wire forming
RK : Metal mixture	3F : 3W		
	3H : 5W		

*** Resistance**

$\overset{1}{\text{---}}\overset{8}{\text{---}}\overset{2}{\text{---}}$ ⇒ 1800 ohm = 1.8 kohm
 Indicates number of zeros after effective number.
 2-digit effective number.

• Units: ohm

$\overset{1}{\text{---}}\overset{R}{\text{---}}\overset{2}{\text{---}}$ ⇒ 1.2 ohm
 1-digit effective number.
 2-digit effective number, decimal point indicated by R.

• Units: ohm

● Capacitors

Ex.: **CE** **04W** **1H** **2R2** **M** **BP**
 Type Shape and performance Dielectric strength Capacity Allowable error Others

CE : Aluminum foil electrolytic	0J : 6.3V	F : ±1%	HS : High stability type
CA : Aluminum solid electrolytic	1A : 10V	G : ±2%	BP : Non-polar type
CS : Tantalum electrolytic	1C : 16V	J : ±5%	HR : Ripple-resistant type
CQ : Film	1E : 25V	K : ±10%	DL : For charge and discharge
CK : Ceramic	1V : 35V	M : ±20%	HF : For assuring high frequency
CC : Ceramic	1H : 50V	Z : +80%	U : UL part
CP : Oil	2A : 100V	-20%	C : CSA part
CM : Mica	2B : 125V	P : +100%	W : UL-CSA type
CF : Metallized	2C : 160V	-0%	F : Lead wire forming
CH : Metallized	2D : 200V	C : ±0.25pF	
	2E : 250V	D : ±0.5pF	
	2H : 500V	= : Others	
	2J : 630V		

*** Capacity (electrolyte only)**

$\overset{2}{\text{---}}\overset{2}{\text{---}}\overset{2}{\text{---}}$ ⇒ 2200μF
 Indicates number of zeros after effective number.
 2-digit effective number.

• Units: μF.

$\overset{2}{\text{---}}\overset{R}{\text{---}}\overset{2}{\text{---}}$ ⇒ 2.2μF
 1-digit effective number.
 2-digit effective number, decimal point indicated by R.

• Units: μF.

*** Capacity (except electrolyte)**

$\overset{2}{\text{---}}\overset{2}{\text{---}}\overset{2}{\text{---}}$ ⇒ 2200pF=0.0022μF
 (More than 2) — Indicates number of zeros after effective number.
 2-digit effective number.

• Units: pF.

$\overset{2}{\text{---}}\overset{2}{\text{---}}\overset{1}{\text{---}}$ ⇒ 220pF
 (0 or 1) — Indicates number of zeros after effective number.
 2-digit effective number.

• Units: pF.

• When the dielectric strength is indicated in AC, "AC" is included after the dielectric strength value.

PARTS LIST OF P.W.B. ASS'Y KU-9356Y CONTROL P.W.B. UNIT ASS'Y

Ref. No.	Part No.	Part Name	Remarks
SEMICONDUCTORS GROUP			
IC601	262 2168 001	IC HD404222	
IC751	263 0927 001	IC BA6208S	
IC752	263 0793 002	IC NJM7806FA(S)	
TR601	269 0020 906	Transistor DTC114ES(10K-10K)	
TR602	269 0090 907	Transistor DTC143XS	
TR603,604	269 0020 906	Transistor DTC114ES(10K-10K)	
TR697,698	271 0191 906	Transistor 2SA1048(GR)	
TR699	269 0020 906	Transistor DTC114ES(10K-10K)	
TR751	274 0183 007	Transistor 2SD2396K	
D601,602	276 0616 907	Diode 1SS252	
D603,604	276 0553 905	Diode 1SR35-200A	
D693	276 0616 907	Diode 1SS252	
D694	276 0616 907	Diode 1SS252	
D695,696	276 0545 900	Diode 1SR139-100	
D697-699	276 0616 907	Diode 1SS252	
ZD601	276 0634 905	Zener diode MTZJ3.3A	3.3V
ZD752	276 0644 966	Zener diode MTZJ12A	12V
RESISTORS GROUP (Not included Carbon Film ±5%)			
△ R491-494	244 2050 933	Metal oxide 180ohm 1W	RS14B3A181JNBS(S)
△ R606	241 2387 940	Carbon film 4.7ohm 1/4W(NB)	RD14B2E4R7JNBS
CAPACITORS GROUP			
△ C001	253 8003 713	Ceramic 4700pF/400VAC	CK45E2GAC472MC
C491	253 1181 904	Ceramic 0.01 μF/50V	CK45F1H103Z
C601	254 4305 968	Electrolytic 1 μF/50V	CE04W1H010M(SRE)
C602	254 4250 932	Electrolytic 220 μF/6.3V	CE04W0J221M
C603	254 4260 919	Electrolytic 0.22 μF/50V	CE04W1HR22M
C604	253 1181 904	Ceramic 0.01 μF/50V	CK45F1H103Z
C605	254 4305 984	Electrolytic 2.2 μF/50V	CE04W1H2R2M(SRE)
C606	255 1265 936	Mylar film 0.01 μF/50V	CQ93M1H103J(B)
C607	253 1181 904	Ceramic 0.01 μF/50V	CK45F1H103Z
C608	254 4250 929	Electrolytic 100 μF/6.3V	CE04W0J101M
C609	254 4250 783	Electrolytic 3300 μF/6.3V	CE04W0J332MC
C610	253 1181 904	Ceramic 0.01 μF/50V	CK45F1H103Z
C753,754	254 4305 968	Electrolytic 1 μF/50V	CE04W1H010M(SRE)

Ref. No.	Part No.	Part Name	Remarks	Q'ty
OTHER PARTS GROUP				
△ SW001	212 1030 009	Power switch (TV-5)	Power	1
△ F001	206 1075 056	Fuse 3.15A		1
△	202 0040 909	Fuse clip (TAPE)		2
WT001	205 0692 000	2P wrapping terminal		1
WT002,003	205 1035 006	1P terminal (1687)		2
CF601	399 0191 903	Ceramic resonator	CST4.00MGW-TF01	1
JK301	204 8320 012	Head phone jack		1
CB3A,3R	205 0343 032	3P connector base (KR-PH)		2
CB3E	205 0233 032	3P EH connector base		1
CN5A	205 0233 058	5P EH connector base		1
CB8B	205 0343 087	8P connector base (KR-PH)		1

KU-9358Y MAIN P.W.B. UNIT ASS'Y

Ref. No.	Part No.	Part Name	Remarks
SEMICONDUCTORS GROUP			
IC302	263 0680 005	IC NJM5532DD	
IP401,402	268 0072 906	IC ICP-N10	IC protector
TR011	269 0046 906	Transistor DTA114ES(10K-10K)	
TR012	269 0020 906	Transistor DTC114ES(10K-10K)	
TR013	274 0183 007	Transistor 2SD2396K	
TR014	272 0146 006	Transistor 2SB1655E	
TR015	271 0287 904	Transistor 2SA933AS(R)	
TR351,352	273 0235 923	Transistor 2SC1841(E/F)	
TR353,354	271 0131 924	Transistor 2SA988(E/F)	
TR355,356	273 0198 905	Transistor 2SC1815(Y)	
TR357,358	271 0131 924	Transistor 2SA988(E/F)	
TR359,360	273 0235 923	Transistor 2SC1841(E/F)	
TR401	273 0303 907	Transistor 2SC1740S(R)	
TR402	269 0020 906	Transistor DTC114ES(10K-10K)	
TR403	273 0303 907	Transistor 2SC1740S(R)	
TR404	269 0169 906	Transistor DTC123JS(2.2K-47K)	
TR405	269 0046 906	Transistor DTA114ES(10K-10K)	
TR406	273 0317 906	Transistor 2SC2458(BL)	
TR407	271 0287 904	Transistor 2SA933AS(R)	
TR408,409	273 0303 907	Transistor 2SC1740S(R)	
TR410	269 0169 906	Transistor DTC123JS(2.2K-47K)	

Ref. No.	Part No.	Part Name	Remarks
TR451,452	273 0235 923	Transistor 2SC1841(E/F)	
Δ D001	276 0339 007	Diode S4VB20F	
D351-356	276 0616 907	Diode 1SS252	
D401-403	276 0553 905	Diode 1SR35-200A	
D405-407	276 0616 907	Diode 1SS252	
D451-454	276 0616 907	Diode 1SS252	
ZD001	276 0645 907	Zener diode MTZJ18A	1.8V
ZD003-005	276 0643 938	Zener diode MTZJ3.0A	3.0V
ZD401,402	276 0635 904	Zener diode MTZJ7.5C	7.5V
ZD403	276 0624 902	Zener diode MTZJ2.0A	2.0V
ZD408	276 0643 938	Zener diode MTZJ3.0A	3.0V
LE751	393 9563 903	SML16751WN	Red, Yellow
P752	279 0034 041	Posistor PTH9M04BD222TS2F333	
SC401	279 0016 904	Thyristor SF0R1A42	

RESISTORS GROUP (Not included Carbon Film ±5%)

Ref. No.	Part No.	Part Name	Remarks
Δ R011,012	241 2387 908	Carbon film 10ohm 1/4W(NB)	RD14B2E010JNBS
R321,322	245 2118 904	Metal film 120kohm 1/4W	RN14K2E124G
R323,324	245 2068 902	Metal film 1kohm 1/4W	RN14K2E102G
R325,326	245 2067 903	Metal film 910ohm 1/4W	RN14K2E911G
R327,328	245 2118 904	Metal film 120kohm 1/4W	RN14K2E124G
Δ R351-354	241 2371 998	Fusible resistor 560ohm 1/4W	RD14B2E561GFRS
Δ R371-374	241 2378 904	Carbon film 180ohm 1/4W(NB)	RD14B2E181JNBS
Δ R375,376	243 2026 032	Winding 0.22ohm 3W	RW==3FR22R22K
Δ R381,382	244 2043 937	Metal oxide 10ohm 1W	RS14B3A100JNBS(S)
R391,392	245 2132 906	Metal film 470kohm 1/4W	RN14K2E474G
Δ R399,400	243 2085 002	Winding 0.1ohm 3W	RW99-3F0R1K
Δ R401,402	244 2051 929	Metal oxide 820ohm 1W	RS14B3A821JNBS(S)
Δ R410,411	244 2052 915	Metal oxide 1.8Kohm 1W	RS14B3A182JNBS(S)
Δ R451,452	241 2380 963	Carbon film 2.2Kohm 1/4W(NB)	RD14B2E222JNBS
Δ R459-464	244 2052 902	Metal oxide 2.7Kohm 1W	RS14B3A272JNBS(S)
VR251	211 0798 116	Variable resistor 250kohm	Balance
VR351,352	211 6093 941	Semi fixed resistor 10kohm	V06PB103
VR751	211 9139 006	Variable resistor 100kohm	Main

CAPACITORS GROUP

Ref. No.	Part No.	Part Name	Remarks
C002	256 1042 903	Metalized 0.1 μF/250V	CF93A2E104K
C003,004	254 6197 006	Electrolytic 8200 μF/56V	CE68W==822MC(DL)
C005,006	255 4081 081	Mylar film 0.1 μF/100V	CQ93P2A104J
C011	254 4260 948	Electrolytic 1 μF/50V	CE04W1H010M
C012	253 1179 903	Ceramic 100pF/50V	CK45B1H101K

Ref. No.	Part No.	Part Name	Remarks
C013,014	254 4256 952	Electrolytic 220 μF/25V	CE04W1E221M
C015,016	256 1034 979	Metalized 0.1 μF/50V	CF93A1H104J
C323,324	255 4238 009	Mylar film 0.47 μF/100V	CQ93P2A474J(ECQ-P)
C325,326	255 4229 908	Mylar film 100pF/100V	CQ92P2A101J
C327,328	254 4252 943	Electrolytic 220 μF/10V	CE04W1A221M
C329,330	255 6180 951	Mylar film 10pF/50V	CQ09S1H100J(SMT)
C351-354	253 4537 966	Ceramic 47pF/50V	CC45SL1H470J
C355,356	256 1035 952	Metalized 0.47 μF/50V	CF93A1H474J
C357,358	255 4199 902	Mylar film 0.1 μF/50V	CQ92M1H104J(MRZ)
C367-369	254 4260 948	Electrolytic 1 μF/50V	CE04W1H010M
C391,392	256 1034 979	Metalized 0.1 μF/50V	CF93A1H104J
C393,394	253 4537 966	Ceramic 47pF/50V	CC45SL1H470J
C395,396	253 1179 945	Ceramic 220pF/50V	CK45B1H221K
C401	254 4263 916	Electrolytic 0.22 μF/100V	CE04W2AR22M
C402	254 4507 902	Electrolytic 470 μF/10V	CE04W1A471M(SRG)
C403	254 4252 927	Electrolytic 47 μF/10V	CE04W1A470M
C405	254 4250 932	Electrolytic 220 μF/6.3V	CE04W0J221M
C451,452	253 1181 904	Ceramic 0.01 μF/50V	CK45F1H103Z
C751	253 1181 904	Ceramic 0.01 μF/50V	CK45F1H103Z
C752	254 3053 907	Electrolytic 10 μF/16V	CE04D1C100MBP
C893	254 4254 909	Electrolytic 10 μF/16V	CE04W1C100M

OTHER PARTS GROUP

Ref. No.	Part No.	Part Name	Remarks	Q'ty
JK001	204 8497 000	4P pin jack(GND)(K)		1
JK002	204 8538 008	6P pin jack(S-GND)		1
JK003	204 8509 008	2P pin jack(C-GND)		1
RL451,452	214 0167 005	Relay(G5Z-2A)		2
RM651	499 0150 008	Remote sensor SBX1610-52		1
SW201	212 2620 007	Slide switch		1
T301	205 0472 000	8P SP terminal(EU)		1
TR361-364	205 1004 011	6P pin header		4
CN10A	205 0536 056	10P connector socket		1
TPL,TPR	205 0190 036	3P NH connector base		2
CB4A	205 0343 045	4P connector base(KR-PH)		1
CB5A	205 0233 058	5P EH connector base		1
CB9B,CN9B	205 0343 090	9P connector base(KR-PH)		2
CB10A,10B	205 0535 057	10P connector base		2
	205 1005 007	1P terminal		3
	415 0299 000	Condenser cover	for C001	1
	415 0309 026	PVC tube(L=20)	for P752	2

PARTS LIST OF EXPLODED VIEW

Ref. No.	Part No.	Part Name	Remarks	Q'ty	Ref. No.	Part No.	Part Name	Remarks	Q'ty
1	KU-9358Y	Main P.W.B.unit Ass'y		1s	45	122 9041 001	Himeron sheet	Top cover	2
1-1	KU-9358Y-1	Amp unit		(1)	46	414 0791 107	Safety cover	Top cover	1
1-2	KU-9358Y-3	Control unit		(1)	47	449 0139 008	Cover holder	Top cover	4
1-3	KU-9358Y-5	Jump unit		(1)	48	513 1642 002	No. sheet		1
2	KU-9356Y	Control P.W.B.unit Ass'y		1s	49	415 9110 009	Insulating sheet		1
2-1	KU-9356Y-1	Power switch,headhone unit		(1)	SCREWS & NUTS				
2-2	KU-9356Y-4	Regulator unit		(1)	71	473 7002 018	Screw 3X8	CBTS (S)-Z	12
3	212 1030 009	Power switch (TV-5)	SW001	1	72	473 7015 018	Screw 3X8	CBTS (S)-B	16
4	204 8320 012	Head phone jack	JK301	1	73	473 7004 016	Screw 4X6	CBTS (S)-Z	2
5	206 1075 056	Fuse (3.15A)	F001	1	74	473 7500 044	Screw 3X8	CBTS (P)-B	14
6	499 0150 008	Remote sensor SBX1610-52	RM651	1	75	477 0064 107	Fixing screw 3X10		6
7-1	212 2621 006	Rotary switch (Remote)		1	76	473 8007 038	Cup screw 3X14		8
7-2	212 2620 007	Slide switch	SW201	1	77	477 0263 005	3P swelling screw		4
8	211 9139 006	Variable resistor 100kohm	Main VR751	1	78	475 6138 002	Volume nut M7		1
9	211 0798 103	Variable resistor 250kohm	Balance VR251	1	79	475 6138 031	Volume nut M9		2
10	254 6197 006	Electrolytic 8200µF/56V	C003,004	2	80	475 6138 002	Volume nut M12		1
11	205 0472 000	8P SP terminal(EU)	T301	1	81	477 0096 007	Push rivet		8
12	204 8497 000	4P pin jack(GND)(K)	JK001	1	82	473 7007 000	Screw 4X8	CBTS (P)-B	4
13	204 8538 008	6P pin jack(S-GND)	JK002	1	PACKING & ACCESORIES (Not included EXPLODED VIEW.)				
14	204 8509 008	2P pin jack(C-GND)	JK003	1	101	511 9468 004	Inst.manual	English	1
15	274 0170 010	Transistor 2SD2401LF202	TR361,362	2	102	504 0125 005	Stylen paper		1
16	2720134018	Transistor 2SB1570LF202	TR363,364	2	103	509 9120 006	Spacer carton		1
17	411 0941 709	Chassis		1	104	505 0131 050	Cabinet cover		1
18	412 4001 004	Side bracket		1	105	503 9306 000	Cushion		2
19	104 0228 401	Foot Ass'y	H=20	4	106	501 9299 069	Carton case		1
20	417 9099 016	Power radiator		1	107	GEN 0225	Control card sub Ass'y		1
21	415 9044 007	Insulating sheet		4					
22	412 9506 009	Radiator bracket		1					
23	412 9507 008	Fix bracket		2					
24	412 4000 005	P.W.B.bracket (A)		2					
25	415 9107 012	Tapping card spacer	L=35.7	2					
26	105 9277 003	Rear panel		1					
27	205 0071 016	Terminal Ass'y	GND	1					
28	477 0018 001	Washer (P-87)		1					
29	206 2132 008	AC cord with plug		1					
30	415 0364 003	UL tube (φ8)	L=50	1					
31	445 0056 008	Cord bush		1					
32	146 9365 000	Inner panel		1					
33	415 9107 009	Tapping card spacer	L=22.2	2					
34	412 9521 000	Volume plate		1					
35	233 6173 007	Power trans		1					
36	462 0094 036	Screw tube		2					
37	112 9149 003	Knob (Fuji)	INPUT SELECTOR	1					
38	144 9257 112	Front panel Ass'y		1					
39	445 8004 007	Wire clamper		10					
40	112 0761 008	Volume knob	VOLUME	1					
41	113 1738 101	Power button		1					
42	112 0555 007	Volume knob (B)	BALANCE	1					
43	461 9087 012	Rubber+PVC sheet	Power trans	1					
44	102 9054 007	Top cover		1					

EXPLODED VIEW OF CHASSIS AND CABINET

PMA-350SE

1 2 3 4 5 6 7 8

WARNING:
Parts marked with this symbol  have critical characteristics.
Use ONLY replacement parts recommended by the manufacturer.

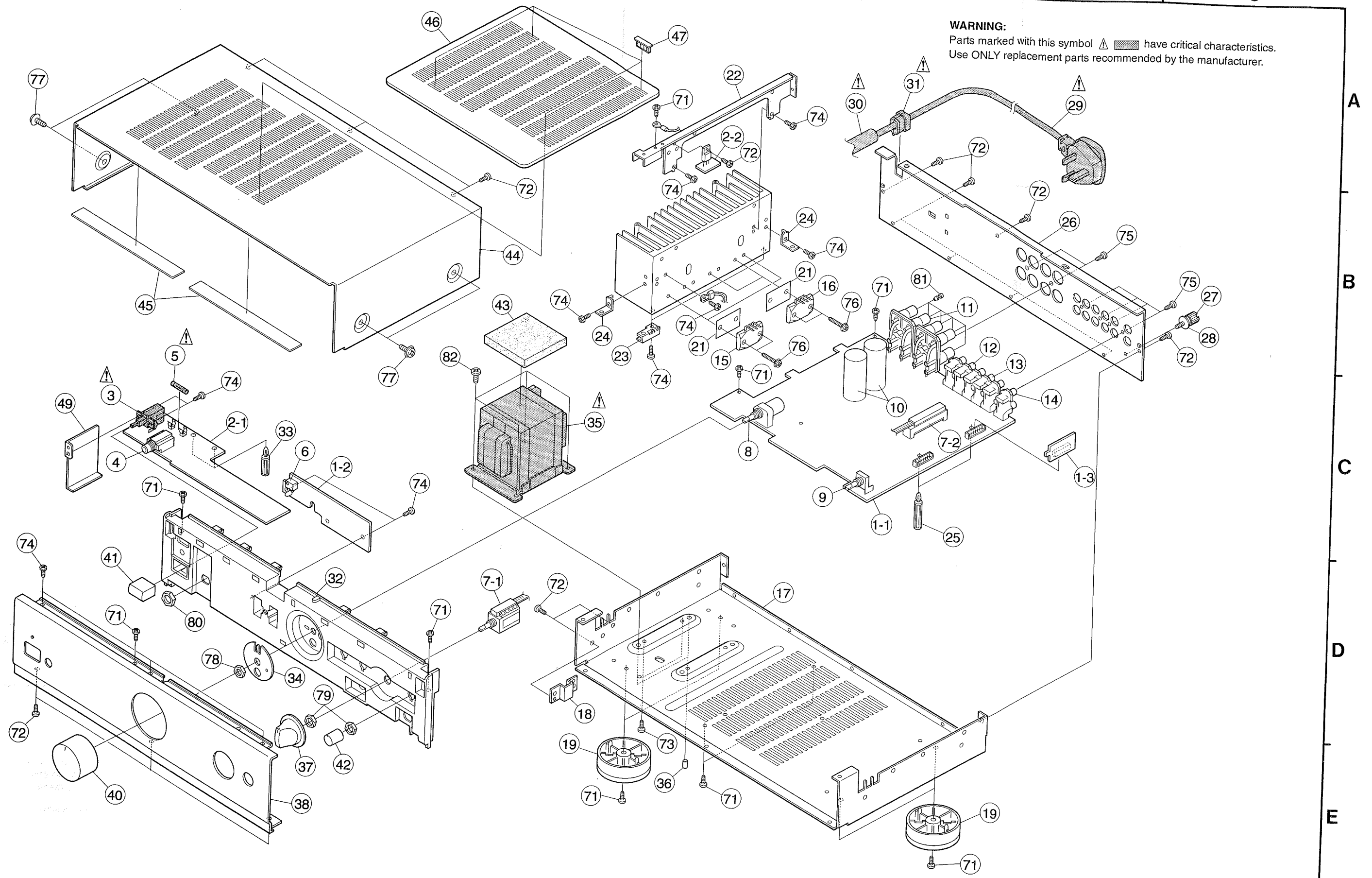

SCHEMATIC DIAGRAM

1 2 3 4 5 6

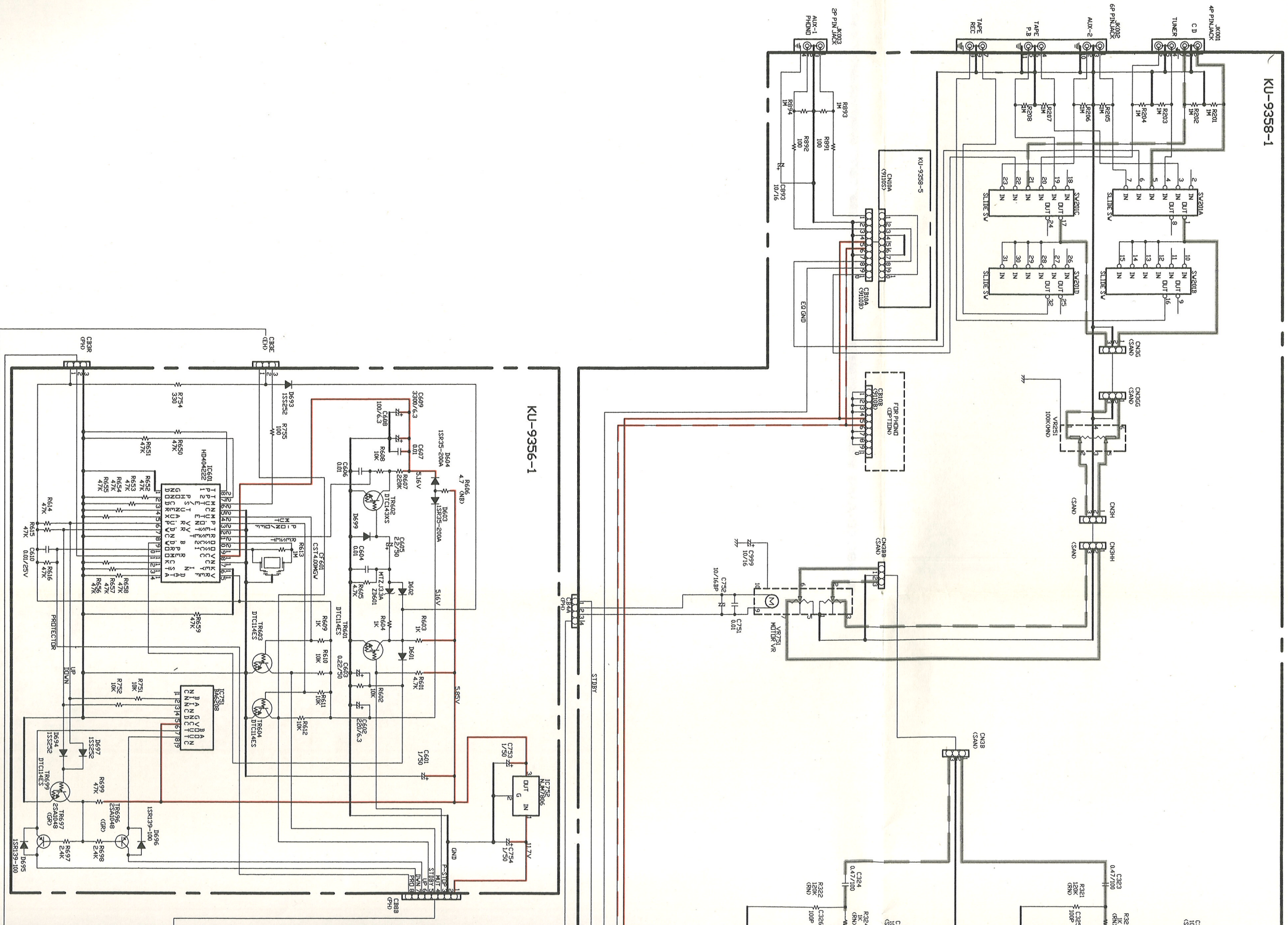

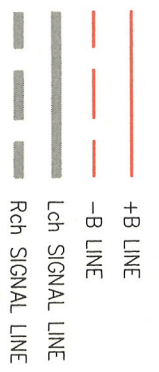
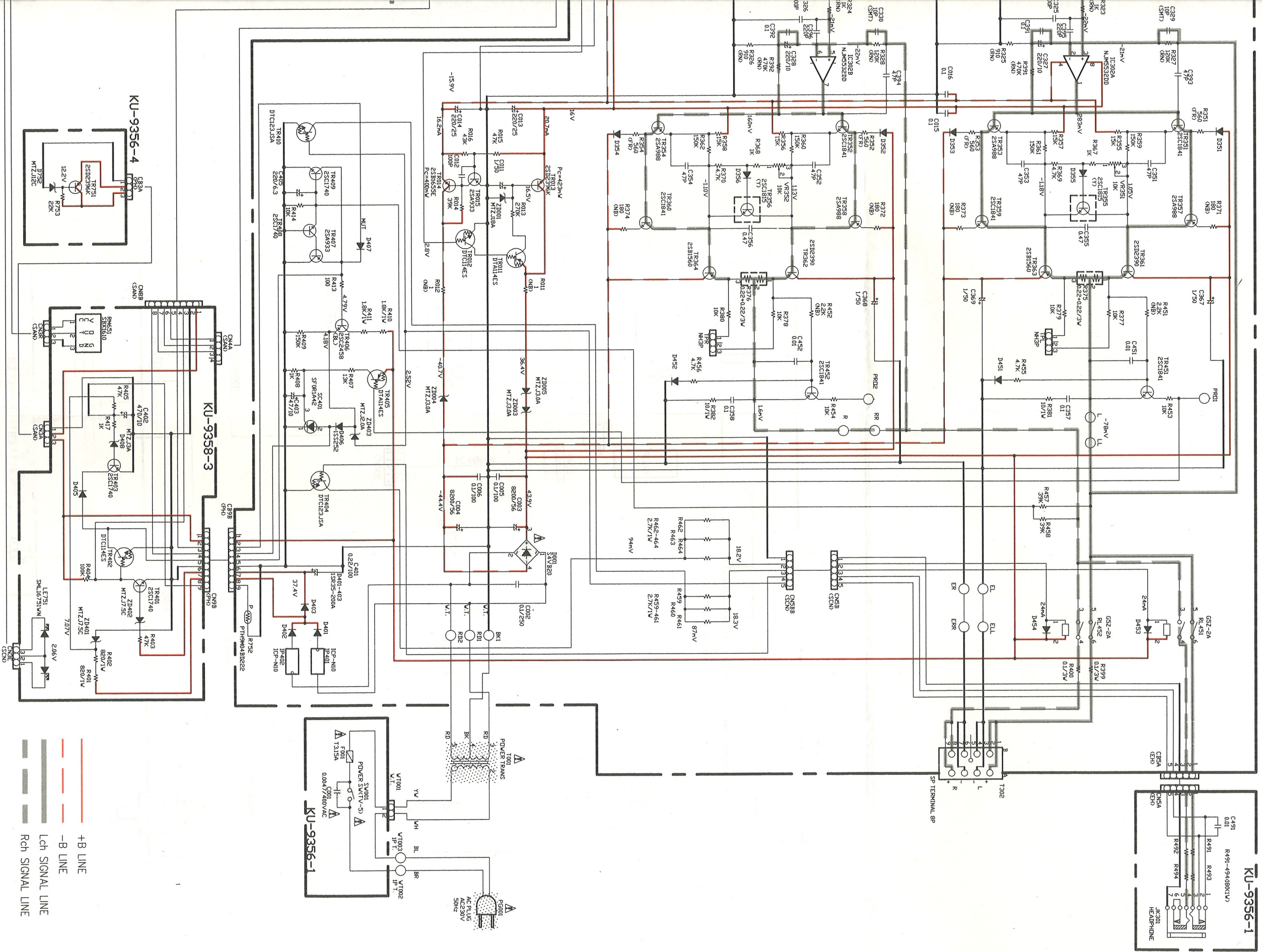

NOTES
 ALL RESISTANCE VALUES IN OHM, K=1,000 OHM, M=1,000,000 OHM
 ALL CAPACITANCE VALUES IN MICRO FARAD, P=PICTO-MICRO FARAD
 EACH VOLTAGE AND CURRENT ARE MEASURED AT NO SIGNAL INPUT
 CIRCUIT AND PARTS ARE SUBJECT TO CHANGE WITHOUT PRIOR
 NOTICE

WARNING:
 Parts marked with this symbol have critical characteristics. Use ONLY replacement parts recommended by the manufacturer.

CAUTION:
 Before returning the unit to the customer, make sure you make either (1) a leakage current check or (2) a line to chassis resistance check. If the leakage current exceeds 0.5 milliamperes, or if the resistance from chassis to either side of the power cord is less than 240 kohms, the unit is defective.

WARNING:
 DO NOT return the unit to the customer until the problem is located and corrected.

WIRING DIAGRAM

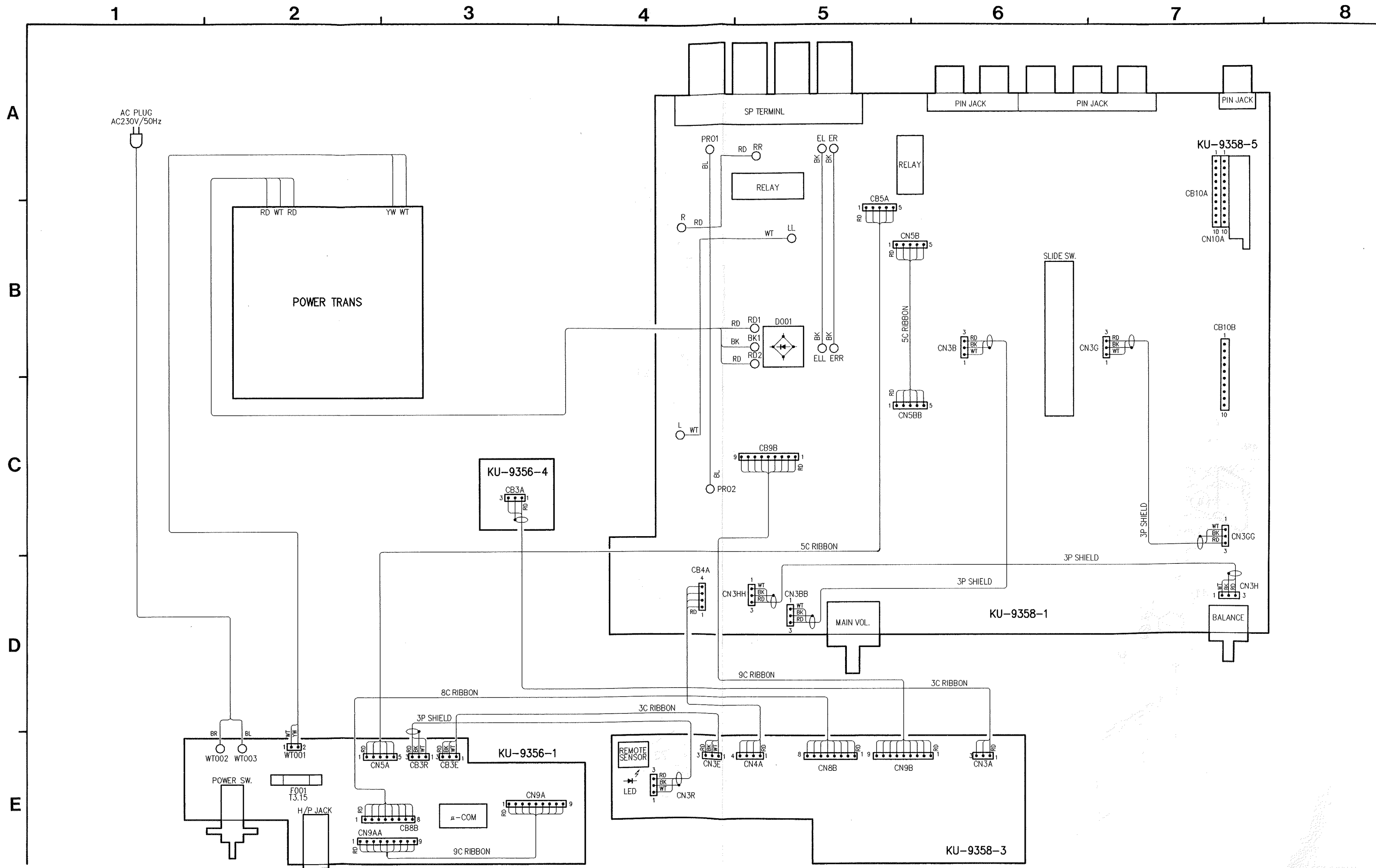

DENON

NIPPON COLUMBIA CO., LTD.

14-14, AKASAKA 4-CHOME, MINATO-KU, TOKYO 107-11 JAPAN

Telephone: 03 (3584) 8111

Cable: NIPPON COLUMBIA TOKYO Telex: JAPANOLA J22591