

# DENON

Hi-Fi Component Amplifier

## SERVICE MANUAL MODEL PMA-530

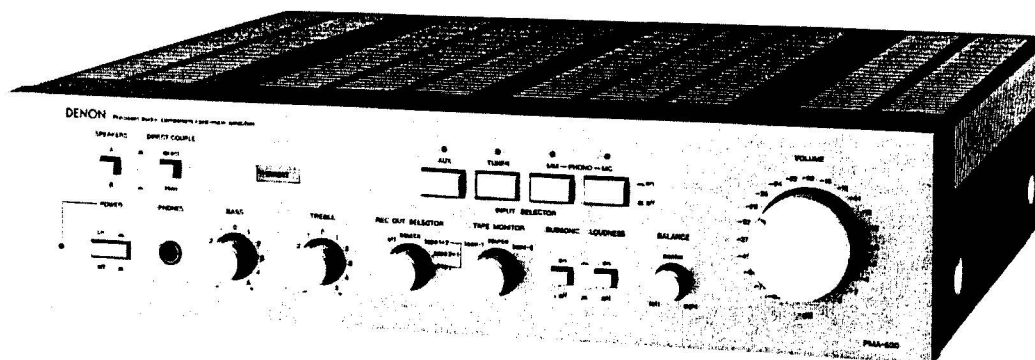

SPECIFICATIONS .....	1
BLOCK DIAGRAM .....	1
METHOD OF ADJUSTMENTS .....	2
NOTES ON SERVICING REMOTE SWITCH .....	3,4
EXPLODED VIEW OF CHASSIS AND CABINET .....	5
PARTS LIST FOR EXPLODED VIEW .....	6
PRINTED CIRCUIT BOARD PATTERNS AND PARTS LIST	
EQ UNIT AUE-007 .....	7,8
CONTROL (B) UNIT AUX-027B .....	9,10
POWER AMP UNIT PUS-014B .....	11~13
POWER SUPPLY UNIT SUX-023B .....	14
POWER SUPPLY UNIT SUX-023C, SUX-023D .....	17
SCHEMATIC CIRCUIT DIAGRAM .....	15,16

# NIPPON COLUMBIA CO., LTD.

# SPECIFICATIONS

## POWER AMPLIFIER SECTION

**Circuit System:** All stage direct DC servo circuit  
**Music Power:** 90 W + 90 W (8 ohm load 1 kHz)  
 130 W + 130 W (4 ohm load 1 kHz)  
**Rated Output Power:** Both channel drive (Tuner to SP out, Vol. -20 dB)  
 20 Hz to 20 kHz/60 W + 60 W  
 1 kHz/60 W + 60 W (8 ohm load T.H.D. 0.003 %)  
 1 kHz/65 W + 65 W (8 ohm load T.H.D. 0.004 %)  
 1 kHz/70 W + 70 W (4 ohm load) (CSA & UL)  
 1 kHz/50 W + 50 W (4 ohm load) (IEC)  
 1 kHz/80 W + 80 W (4 ohm load) DIN (Subject to change by temperature test)  
**Total Harmonic Distortion:** Less than 0.008 % (20 Hz to 20 kHz -3dB at rated output)  
**Intermodulation Distortion:** 7 kHz/60 Hz - 1/4 lower than 0.003 % at amplitude output equivalent to rated output  
**Power Bandwidth:** 5 Hz to 100 kHz 0.1 % T.H.D. IHF  
**Transmission Characteristic:** 1 Hz to 400 kHz +0 dB, -3 dB at 1 W output  
**Input Sensitivity:** 150 mV r.m.s.  
**Input Impedance:** 30 k ohm  
**Output Impedance:** Less than 0.06 ohm at 1 kHz  
**Signal to Noise Ratio:** 100 dB (input terminals shorted out IHF/A network)  
**Output Terminals:**  
**Speakers:** 4 to 16 ohm load  
**Headphone:** For Stereo Headphone

## EQUALIZER AMPLIFIER SECTION

**Equalizer Amplifier Output (REC out Terminal)**  
**Max. Output:** 13 V at 50 k ohm load  
**Rated Output:** 150 mV  
**Total Harmonic Distortion:** Less than 0.002 % at 1kHz 8 V output  
**Input Sensitivity/Input Impedance**  
**Phono (MM):** 2.5 mV/50 k ohm  
**Phono (MC):** 0.25 mV/100 ohm  
**Tuner:** 150 mV/30 k ohm  
**Aux. Tape:** 150 mV/30 k ohm

## RIAA Deviation:

**Phono (MM):** Within ±0.2 dB (20 Hz to 20 kHz)  
**Phono (MC):** Within ±0.2 dB (30 Hz to 20 kHz)

## Maximum Input Level

**Phono (MM):** 200 mV, 1 kHz  
**Phono (MC):** 20 mV, 1 kHz

## OVERALL CHARACTERISTICS

### Signal to Noise Ratio (IHF, A network)

**Phono (MM):** Better than 88 dB (input terminals shorted out)  
**Phono (MC):** Better than 72 dB (input terminals shorted out)  
**Tuner, Tape, Aux:** Better than 100 dB (input terminals shorted out)

### Tone Control Section

#### Variable Range

**Bass:** 100 Hz ±8 dB  
**Treble:** 10 kHz ±8 dB

### Filter Characteristic

**Subsonic:** 20 Hz, 6 dB/oct.  
**Loudness:** +9 dB at 100 Hz, +5 dB at 10 kHz

## POWER REQUIREMENT

**France & Germany:** AC 220 V, 50 Hz  
**U.K & Australia** AC 240 V, 50 Hz  
**U.S.A. & Canada** AC 120 V, 60 Hz

## POWER CONSUMPTION

**UL:** 190 W  
**CSA:** 390 VA  
**IEC:** 485 W at maximum output

## AC OUTLET (for USA & Canada)

**Unswitched:** 250 W maximum x 1  
**Switched:** 100 W maximum x 2 (total)

## DIMENSIONS:

434 mm(W) x 112 mm(H) x 390 mm(D)  
 17-5/64"(W) x 4-13/32"(H) x 15-23/64"(D)  
 (including rubber feet, knobs and terminals)

## WEIGHT:

11.0 kg, 24.2 lbs

**NOTE:** The following codes correspond to the appropriate models.

2DX for Europe, 2DA for Australia, 2DUK for U.K., 1DC for Canada, 1DU for U.S.A.

## BLOCK DIAGRAM

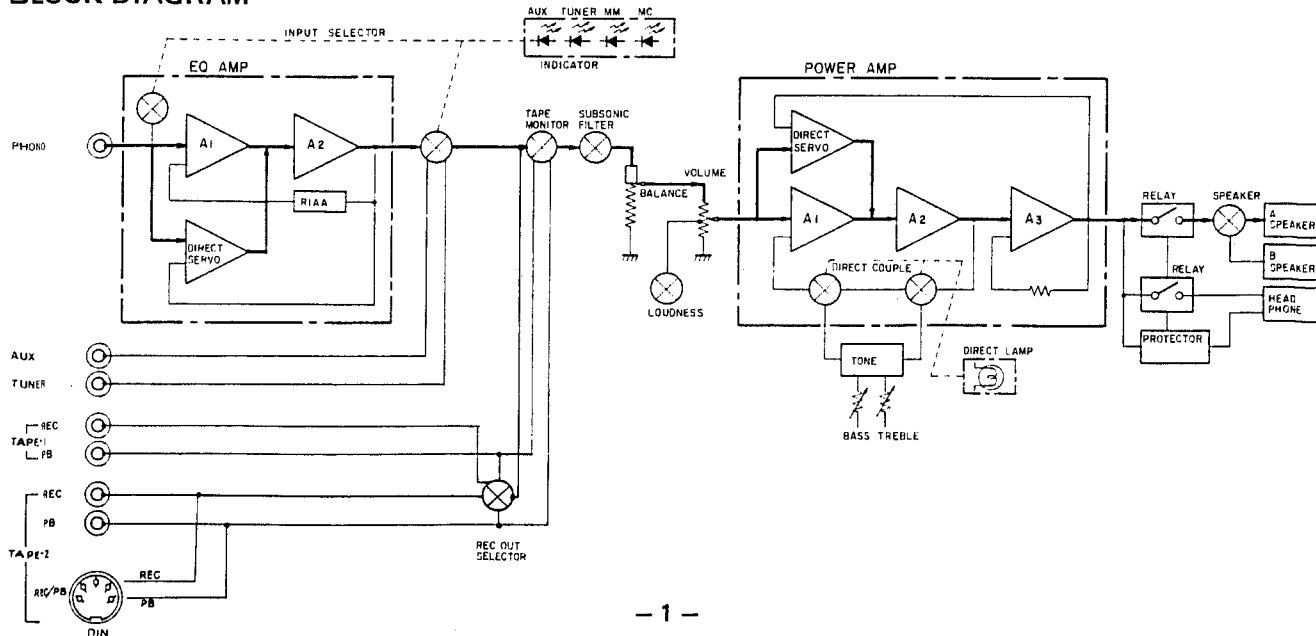

## METHOD OF ADJUSTMENT

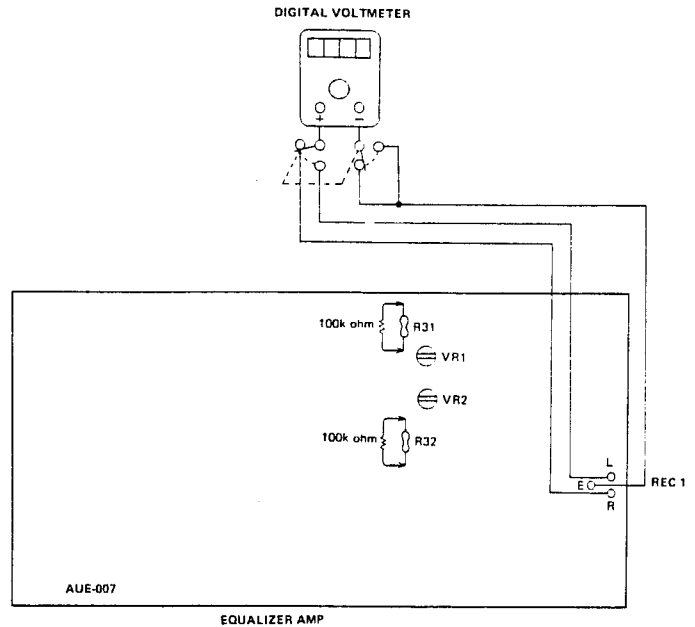
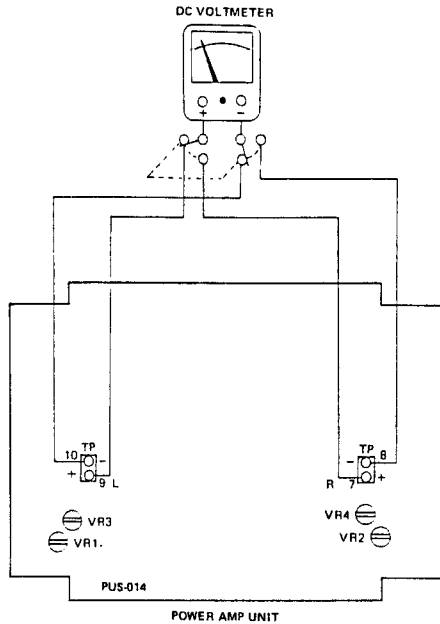

### IDLE CURRENT ADJUSTMENT METHOD OF POWER AMP (PUS-014 PRINTED BOARD)

- Place the unit in normal position, not sideways or tilted. Avoid too much ventilation, since the adjustment must be done where temperature is between 15°C and 30°C.
- Set the switches on the unit as follows:
 

Power	→ OFF
Volume	→ $-\infty$ dB
Direct couple	→ Direct
Speaker terminals	→ No load (no speaker connected)
- Remove the top cover, and the VR1 and VR2 of the power amp printed board (2220444101) fully clockwise and VR3 and VR4 fully counter clockwise.  
Connect a DC voltmeter to the test points 7(+), 8(-) or to 9(+), 10(-).
- Plug in the AC cord to power outlet of: Europe 220 V (198~231 V); U.K. and Australia 240 V (216~252 V); Canada and U.S.A. 120 V (108~126 V); and turn the power on.  
Immediately (within one minute), turn VR1 and VR2 counterclockwise and adjust the test point voltage (VTP) to  $7 \pm 2$  mV preliminarily.
- After about two or three minutes of the above preliminary adjustment, adjust VR1 and VR2 so as VTP reads  $8.2 \pm 2$  mV.
- Adjust VR3 and VR4 so as VTP reads  $\pm 20$  mV preliminarily.
- About 10 minutes after the above preliminary adjustment, adjust VR3 and VR4 so as VTP reads  $27 \pm 2$  mV. Or 30 minutes or more after the preliminary adjustment, adjust VR3 and VR4 so as VTP reads  $31 \pm 2$  mV.

### ADJUSTMENT OF EQUALIZER (AUE-007 PRINTED BOARD)

- Insert short pins into PHONE input terminals.
- Connect a digital voltmeter (0.01 mV ~ 1 mV DC range must be measurable) into each of REC. out terminals (L & R channels).
- For easier measuring to avoid value fluctuation on the meter, connect a 100 k ohm (1/4W) resistor between the ends of the R31/32 10 M ohms (1/4W) resistor on the printed board.
- Set the FUNCTION switch to "MM" position, and turn the main volume to MIN.

### ADJUSTMENT

- Turn POWER on, and after two minutes warming-up conduct the following adjustments.
- Adjust VR1 (100 ohms semi-solid volume), so as the L-channel digital voltmeter reads 0.5 mV DC or less.
- Adjust VR2 (100 ohm semi-solid volume), so as the R-channel digital voltmeter reads 0.5 mV DC or less.

## NOTES ON SERVICING REMOTE SWITCH

### A. How to remove control wire (TAPE MONITOR, REC OUT SELECTOR).

- (1) Do not handle Adapter pins (4) forcedly.
- (2) Do not pull the wire to detach adapter.
- (3) Procedure to remove.
  - (a) Use a thin blade or tip-bent plier (See Fig. 1).

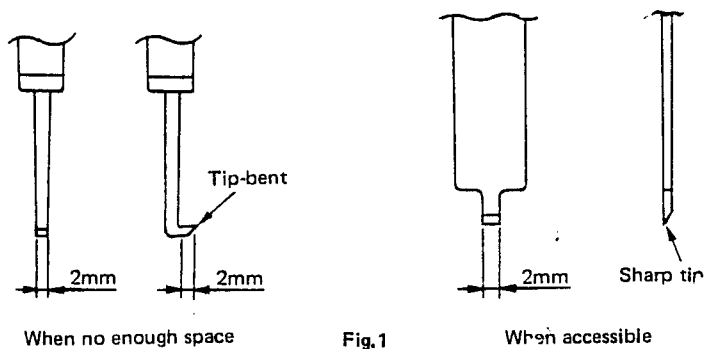

- (b) Lever to off as per Fig. 2,3 4.

Step-1: Apply the implement to one of 4 legs and tilt it to ⇒ direction, and hold the adapter with finger(Fig. 3).

Step-2: Slightly lift the adapter from the frame, and use the implement on (b) (Fig. 4).

Step-3: Move the adapter to ⇐ direction to remove it.

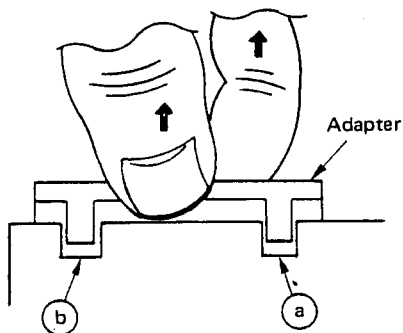

Fig.2

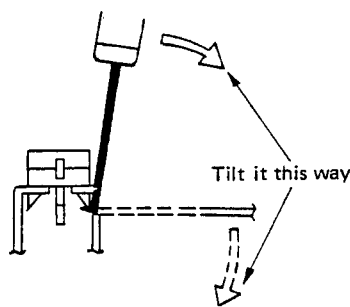

Fig.3

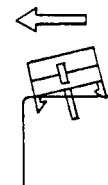

Fig.4

- (4) Do not apply implement forcedly or the leg may break off.
- (5) If the leg (a) is not loose, the adapter won't come off even if leg (b) is loose. Then repeat step-1.

### B. HOW TO INSTALL CONTROL WIRE

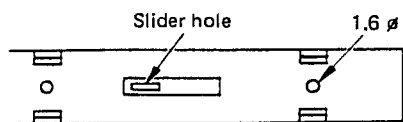
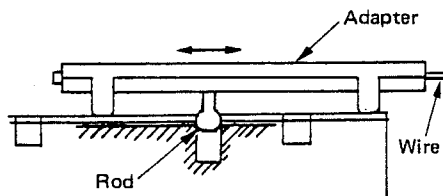

Fig.5



- (1) Turn rotary control shaft on front panel side fully counterclockwise.
- (2) Fit the rod to slider hole on controller side, slide the adapter to either side of the control wire, push it to snap it in. (See Fig.6)

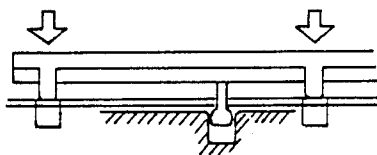

Fig.6

- (3) Hold adapter on switch side, and move it to switch frame rear.
- (4) Slide the switch to opposite side of the control wire with a thin implement.
- (5) Fit adapter wire to 1.6mm hole in frame rear, and snap it in.
- (6) Turn the control to check.

**C. PRECAUTIONS**

- (1) Check adapter lags not deformed.
- (2) Check adapter guides mate the legs.
- (3) Follow step (B), and push the legs in as per figure below.

**Example 1:**

- a. Fit drive plate to slide hole and adapter mounting legs. Fit 1.6mm hole on switch wire side to the 1.6mm hole on the adapter.
- b. Push (A) or (B). Push all other (A) and (B) if left unfixed.
- c. (A) and (B) can be pushed at a time.

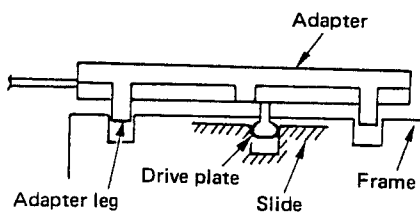

Fig.7

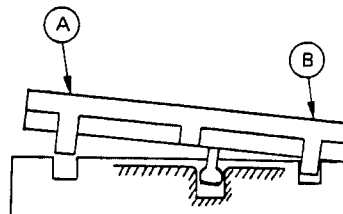

Fig.8

**Example 2:**

- a. Fit drive plate to slide and adapter.
- b. Snap in longer legs first.
- c. And then snap in opposite ones.

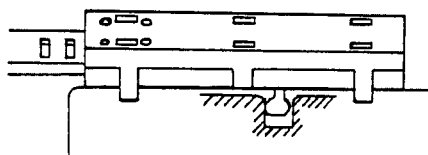

Fig.9



Fig.10

**D. HOW TO PUSH (DIRECT SWITCH)**

- (1) Set control lever to unlocked position.
- (2) Fit adapter to rod position and snap it in controller side.
- (3) Use a thin implement to move the switch to control wire side.
- (4) Fit the adapter position and push it in.
- (5) Push the controller and check it move smoothly.

**E. HOW TO PUSH (SPEAKER SWITCH)**

- (1) Hold the case when remove and install the speaker switch.

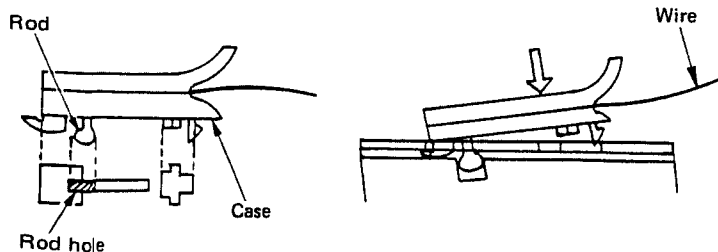

Fig.11 How to install

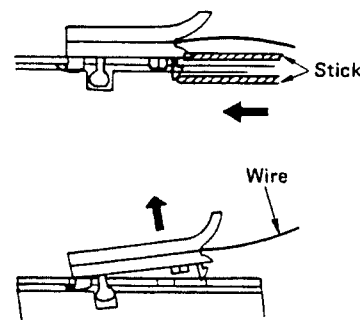
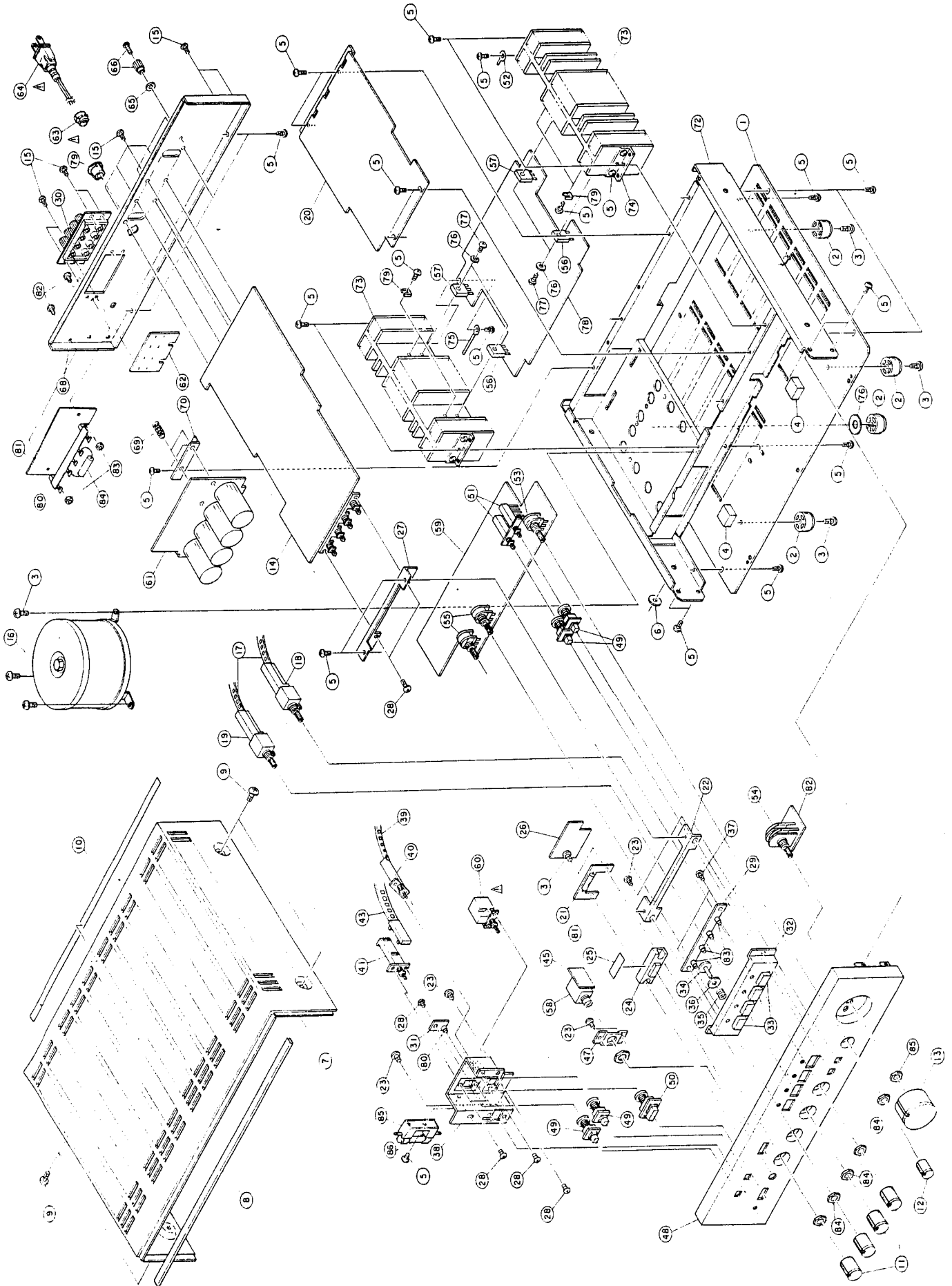

Fig.12 How to remove

# EXPLODED VIEW OF CHASSIS AND CABINET



PMA-530 EXPLODED VIEW PARTS LIST

Note: See addendum list below for the parts with asterisk(\*) on the Ref. No. and the other parts not included in this list.

Ref. No.	Part No.	Part Name & Descriptions	Ref. No.	Part No.	Part Name & Descriptions
1	1050297008	BOTTOM COVER	44	-	-
2	1048001002	FOOT	*45	AUX-027B-3	HEAD PHONE JACK UNIT
3	4730455015	TAPPING SCREW (2) 4 x 10	46	-	SPECIAL NUT 12 mm
4	4610121016	CUSHION	47	4120484007	HEAD PHONE BRACKET
5	4730354019	TAPPING SCREW (2) 3 x 8	48	1440569304	FRONT PANEL
6	-	-	49	1130134162	PUSH KNOB ASS. USED 4
7	1020090206	TOP COVER	50	1130134175	PUSH KNOB ASS. USED 1
8	1220007057	SPACER	51	2124188000	2P PUSH SWITCH
9	4734801005	TAP TIGHT SCREW 4 x 8	52	2124186002	SLIDE SWITCH (REMOTE)
10	1220007086	SPACER	53	2110230001	V1620V25KW104K BALANCE
11	1120263108	KNOB	54	2110192000	V2420V25KA503 MAIN VOLUME
12	1120264107	KNOB	55	2110229009	V1620V25KC104K BASS. TREBLE
13	1120265106	KNOB	56	2730177007	2SC1626(Y) TRANSISTOR
*14	AUE-007-1	EQ & CONTROL (A) UNIT	57	4170021009	RADIATOR
15	4770064107	FIXING SCREW	58	2048063007	HEAD PHONE JACK
*16	2335211009	POWER TRANS.	*59	AUX-027B-1	CONTROL (B) UNIT
17	4350045009	FLEXIBLE SLIDER	*60	2124049055	PUSH SWITCH
18	2120152001	ROTARY REMOTE (A)	*61	SUX-023B-1	POWER SUPPLY UNIT
19	2120153000	ROTARY REMOTE (B)	*62	SUX-023B-5	SPEAKER TERMINAL UNIT
20	4120620007	SHIELD PLATE	*63	4450020005	CORD BUSH
21	AUX-007B-4	DIRECT LAMP UNIT	*64	2062016001	AC CORD
22	4120616008	BRACKET	65	4770018001	WASHER
23	4730454016	TAPPING SCREW (2) 4 x 8	66	2050071016	TERMINAL
24	1430149006	LENS ASS.	67	-	-
25	1430110048	FILTER	*68	1050312103	BACK PANEL
26	-	-	69	MD-5271	P.C.B. SUPPORT
27	4120618103	SWITCH BRACKET	70	4120621006	P.W. BRACKET
28	4700009006	CROSS PAN SCREW WITH S. WASHER 3x6	71	-	-
29	AUX-007B-2	LED UNIT	72	4110218209	CHASSIS ASS.
30	2124187001	SLIDE SWITCH (REMOTE)	73	4170115009	POWER RADIATOR
31	SUX-023B-3	POWER LED UNIT	74	4120329007	BRACKET
32	1140047207	PANEL BUSH (A)	75	EP-4772	CORD HOLDER
33	1130171206	PUSH KNOB ASS.	76	4751003006	WASHER 3 mm
34	1190014002	STOPPER	77	4700012006	CROSS PAN SCREW WITH SWASHER 3x12
35	4630220007	SPRING	*78	PUS-014B	POWER AMP UNIT
36	-	-	79	2038084009	5P CONNECTOR (DIN)
37	4730304014	TAPPING SCREW (1) 3 x 8	*80	2050089008	7P W/TERMINAL
38	4120617201	PANEL BRACKET	*81	4150088004	INSULATING SHEET
39	4350044026	FLEXIBLE SLIDER	*82	4700042005	CROSS PAN SCREW WITH S.WASHER 3x8
40	2124185003	PUSH REMOTE SWITCH	*83	4756006008	NUT 3 mm
41	2124190001	PUSH SWITCH (REMOTE)	*84	2518001007	0.01 μF OIL CAPACITOR 450V
42	-	-	*85	2020013004	FUSE HOLDER
43	4350046008	FLEXIBLE SLIDER	*86	2061015074	FUSE 3.15 A

ADDENDUM LIST

Ref. No.	Part Name & Descriptions	2DA For Australia	2DUK For U.K.	1DC For Canada	1DU For U.S.A.
14	EQ UNIT	AUE-007-1	AUE-007-1	AVE-007B-1	AVE-007-1
16	POWER TRANS ASSEMBLY	2335217003	2335221002	2335219001	2335219001
45	HEAD PHONE JACK UNIT	AUX-027B3	AUX-027B3	AUX-027C3	AUX-027B3
59	CONTROL (B) UNIT	AUX-027B1	AUX-027B1	AUX-027C1	AUX-027B1
60	POWER SW	2124049055	2124049055	2124049097	-
61	POWER SUPPLY UNIT	SUX-023B1	SUX-023B1	SUX-023C1	SUX-023D1
62	SPEAKER TER. UNIT	SUX-023B5	SUX-023B5	SUX-023C5	SUX-023D5
63	CORD BUSH	MD-2982H	MD-2982H	MD-3802	MD-3802
64	A.C. CORD	2062012005	2062020000	2062019008	2062019008
68	BACK PANEL	1050312103	1050312103	1050318000	1050319009
78	POWER AMP UNIT	PUS-014B	PUS-014B	PUS-014C	PUS-014B
80	7P W. TERMINAL	-	2050089008	-	-
81	INSULATING SHEET	4150094001	4150088004	-	-
82	CROSS PAN SCREW WITH S. WASHER (BLACK)	-	4700042005	-	-
83	3 NUT ZN	-	4756006008	-	-
84	0.01μF 20% 450V METALIZED CAPACITOR	2518001007	2518001007	-	-
85	FUSE HELDER	2020013004	2020013004	-	-
86	FUSE	2061015074	2061015074	2061023082	2061023082
	EARTH LABEL	-	5130140000	-	-
	3 TOOTH WASHER NI	-	4753001051	-	-
	AC OUTLET	-	-	2032052008	2032052008
	VOLTAGE LABEL	5130362008	5130362008	-	-
	4TWA NI	4753100004	4753100004	-	-
	FUSE LABEL	5130159143	5130159143	5130270064	5130270064
	POWER SW UNIT	SUX-023B4	-	SUX-023C4	SUX-023D4
	POWER LED UNIT	SUX-023B2	SUX-023B2	SUX-023C2	SUX-023D2
	DIRECT LAMP UNIT	AUX-027B4	AUX-027B4	AUX-027C4	AUX-027B4
	3P TERMINAL BLOCK	2050086014	-	-	-
	CROSS PAN SCREW WITH SPRING	4700042083	-	-	-
	WASHER 3 x 16	-	-	-	-
	3 WASHER	4751003006	-	-	-
	3 NUT	4756006008	-	-	-
	WIRE ASSEMBLY	2030176119	-	-	-
	0.047μF ±20% 125V METALIZED CAPACITOR	-	-	2568019010	2568019010
	SERIAL NO PLATE	-	-	-	513038137
	RIVET	-	-	-	4770126016

# PRINTED CIRCUIT BOARD PATTERNS AND PARTS LIST

AUE-007 (for 2DX, 2DA, 2DUK, 1DU), AUE-007B (for 1DC) EQ./LED LAMP UNIT

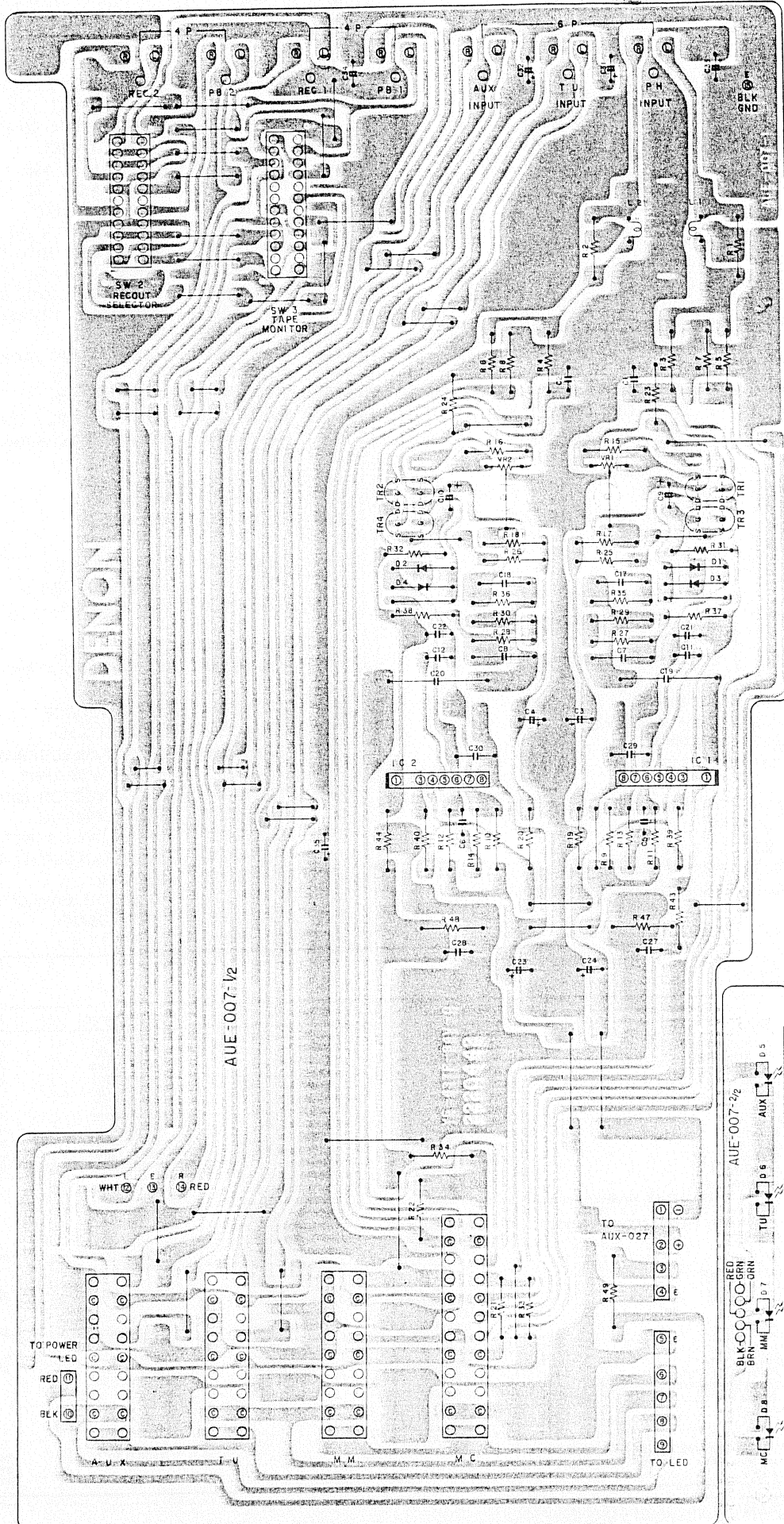



## AUE-007 PARTS LIST

Ref. No.	Part No.	Part Name & Descriptions		Ref. No.	Part No.	Part Name & Description	
<b>SEMICONDUCTORS</b>				<b>CAPACITORS</b>			
IC1	2630103003	HA12017	INTEGRATED CIRCUIT	C1	2533629008	120 pF ±5%	50V FIXED CERAMIC
IC2	2630103003	HA12017	INTEGRATED CIRCUIT	C2	2533629008	120 pF ±5%	50V FIXED CERAMIC
TR1	2750026002	2SK146(GR)	FIELD EFFECT TRANSISTOR	C3	2544028009	100 μF	25V FIXED ELECTROLYTIC
TR2	2750026002	2SK146(GR)	FIELD EFFECT TRANSISTOR	C4	2544028009	100 μF	25V FIXED ELECTROLYTIC
TR3	2750026002	2SK146(GR)	FIELD EFFECT TRANSISTOR	C5	2551120042	0.0022 μF ±5%	25V FIXED PLASTIC FILM
TR4	2750026002	2SK146(GR)	FIELD EFFECT TRANSISTOR	C6	2551120042	0.0022 μF ±5%	25V FIXED PLASTIC FILM
D1	2760049008	1S2076	DIODE	C7	2554083005	0.056 μF ±2%	100V FIXED PLASTIC FILM
D2	2760049008	1S2076	DIODE	C8	2554083005	0.056 μF ±2%	100V FIXED PLASTIC FILM
D3	2760049008	1S2076	DIODE	C9	2541001003	4.7 μF ±20%	6.3V FIXED ELECTROLYTIC
D4	2760049008	1S2076	DIODE	C10	2541001003	4.7 μF ±20%	6.3V FIXED ELECTROLYTIC
D5	3939040002	TLG206	LIGHT EMITTING DIODE	C11	2533641002	390 pF ±5%	50V FIXED CERAMIC
D6	3939040002	TLG206	LIGHT EMITTING DIODE	C12	2533641002	390 pF ±5%	50V FIXED CERAMIC
D7	3939040002	TLG206	LIGHT EMITTING DIODE	C17	2554083018	0.015 μF ±2%	100V FIXED PLASTIC FILM
D8	3939040002	TLG206	LIGHT EMITTING DIODE	C18	2554083018	0.015 μF ±2%	100V FIXED PLASTIC FILM
<b>RESISTORS</b>				<b>OTHER PARTS</b>			
R1	2410298002	220 ohm ±5%	1/4W FIXED CARBON FILM		2220442103	P.C.BOARD	
R2	2410298002	220 ohm ±5%	1/4W FIXED CARBON FILM		2032068005	2P CONNECTOR BASE	
	2410266005	10 ohm ±5%	1/4W FIXED CARBON FILM		2038079001	5P CONNECTOR BASE	
	2410266005	10 ohm ±5%	1/4W FIXED CARBON FILM		2036790003	4P CONNECTOR BASE	
R5	2410290000	100 ohm ±5%	1/4W FIXED CARBON FILM		2034111044	3P CONNECTOR FOR EQ OUT	
R6	2410290000	100 ohm ±5%	1/4W FIXED CARBON FILM		2038069011	5P CONNECTOR CORD FOR LED	
R7	2410355000	51 kohm ±5%	1/4W FIXED CARBON FILM		2030170005	1P CONTACT	
R8	2410355000	51 kohm ±5%	1/4W FIXED CARBON FILM	SW1	2124184004	4P PUSH SWITCH 4 GANG	
R9	2462003041	4.3 kohm ±3%	1/4W FIXED METAL COMPOSIT	SW2	2124187001	SLIDE SWITCH (Remote) 4 CIRCUIT 3 POSITION	
R10	2462003041	4.3 kohm ±3%	1/4W FIXED METAL COMPOSIT	SW3	2124187001	SLIDE SWITCH (Remote) 4 CIRCUIT 3 POSITION	
R11	2462003041	4.3 kohm ±3%	1/4W FIXED METAL COMPOSIT	VR1	2116021007	VARIABLE RESISTOR 100 kohm	
R12	2462003041	4.3 kohm ±3%	1/4W FIXED METAL COMPOSIT	VR2	2116021007	VARIABLE RESISTOR 100 kohm	
R13	2410284003	56 ohm ±5%	1/4W FIXED CARBON FILM	L1	2318017000	INDUCTOR 18 μH	
R14	2410284003	56 ohm ±5%	1/4W FIXED CARBON FILM	L2	2318017000	INDUCTOR 18 μH	
*R15	2410266005	10 ohm ±5%	1/4W FIXED CARBON FILM		4140116106	SHIELD COVER	
*R16	2410266005	10 ohm ±5%	1/4W FIXED CARBON FILM		2048021007	4P CONNECTOR BASE FOR INPUT	
R17	2410328008	3.9 kohm ±5%	1/4W FIXED CARBON FILM		2040061007	6P CONNECTOR BASE FOR INPUT	
R18	2410328008	3.9 kohm ±5%	1/4W FIXED CARBON FILM		209008146	JUMPER SHORT LEAD USED-3 P = 5 mm	
R19	2410312001	820 ohm ±5%	1/4W FIXED CARBON FILM		2090008133	JUMPER SHORT LEAD USED-7 P = 7.5 mm	
R20	2410312001	820 ohm ±5%	1/4W FIXED CARBON FILM		2090008120	JUMPER SHORT LEAD USED-7 P = 10 mm	
R21	2410267004	11 ohm ±5%	1/4W FIXED CARBON FILM		2090008117	JUMPER SHORT LEAD USED-19 P = 12.5 mm	
R22	2410267004	11 ohm ±5%	1/4W FIXED CARBON FILM		2090008104	JUMPER SHORT LEAD USED-5 P = 15 mm	
R23	2410290000	100 ohm ±5%	1/4W FIXED CARBON FILM		2090008162	JUMPER SHORT LEAD USED-5 P = 20 mm	
R24	2410290000	100 ohm ±5%	1/4W FIXED CARBON FILM		4120618103	SWITCH BRACKET	
R25	2410328008	3.9 kohm ±5%	1/4W FIXED CARBON FILM		4700009006	CROSS PAN SCREW WITH S. WASHER 3 x 6 FOR SW. BRACKET FIXED	
	2410328008	3.9 kohm ±5%	1/4W FIXED CARBON FILM	<b>AUE-007B PARTS LIST (for Canada model - 1DC)</b>			
R27	2412018044	56 kohm ±2%	1/4W FIXED CARBON FILM	Ref. No.	Part No.	Part Name & Descriptions	
R28	2412018044	56 kohm ±2%	1/4W FIXED CARBON FILM	R15	2410274000	22 ohm ±5% 1/4W FIXED CARBON FILM	
R29	2410302008	330 ohm ±5%	1/4W FIXED CARBON FILM	R16	2410274000	22 ohm ±5% 1/4W FIXED CARBON FILM	
R30	2410302008	330 ohm ±5%	1/4W FIXED CARBON FILM				
R31	2420203003	10 Mohm ±10%	1/4W FIXED CARBON COMPOSIT				
R32	2420203003	10 Mohm ±10%	1/4W FIXED CARBON COMPOSIT				
R33	2410377004	430 kohm ±5%	1/4W FIXED CARBON FILM				
R34	2410377004	430 kohm ±5%	1/4W FIXED CARBON FILM				
R35	2412032046	4.7 kohm ±2%	1/4W FIXED CARBON FILM				
R36	2412032046	4.7 kohm ±2%	1/4W FIXED CARBON FILM				
R37	2410273001	20 ohm ±5%	1/4W FIXED CARBON FILM				
R38	2410273001	20 ohm ±5%	1/4W FIXED CARBON FILM				
R39	2410346006	22 kohm ±5%	1/4W FIXED CARBON FILM				
R40	2410346006	22 kohm ±5%	1/4W FIXED CARBON FILM				
R43	2410290000	100 ohm ±5%	1/4W FIXED CARBON FILM				
R44	2410290000	100 ohm ±5%	1/4W FIXED CARBON FILM				
R47	2410362006	100 kohm ±5%	1/4W FIXED CARBON FILM				
R48	2410362006	100 kohm ±5%	1/4W FIXED CARBON FILM				
R49	2440046020	2.7 kohm ±5%	1W FIXED METAL OXIDE FILM FORMING TYPE				
R51	2410290000	100 ohm ±5%	1/4W FIXED CARBON FILM				
R52	2410290000	100 ohm ±5%	1/4W FIXED CARBON FILM				

All other parts are the same as AUE-007.

AUX-027B (for 2DX, 2DA, 2DUK, 1DU), AUX-027C (for 1DC)

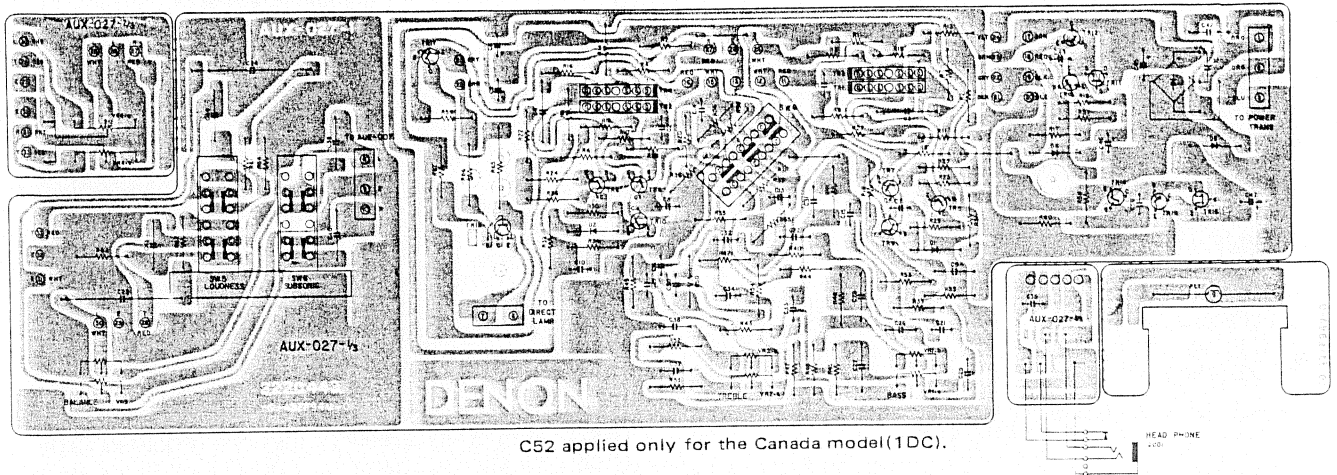

C52 applied only for the Canada model (1DC).

AUX-027C (for Canada model – 1DC)

Ref. No.	Part No.	Part Name & Descriptions
C52	2531053003	0.01μF +100% -0% 500V FIXED CERAMIC

All other parts are the same as AUX-027B

AUX-027B PARTS LIST

Ref. No.	Part No.	Part Name & Descriptions	Ref. No.	Part No.	Part Name & Description
<b>SEMICONDUCTORS</b>					
TR1	2750024004	MPA68H(K) FIELD EFFECT TRANSISTOR	D1	2760171028	HV-23G(YL) DIODE
TR2	2750024004	MPA68H(K) FIELD EFFECT TRANSISTOR	D2	2760171028	HV-23G(YL) DIODE
TR3	2750024004	MPA68H(K) FIELD EFFECT TRANSISTOR	D4	2760239009	SIRBA20F DIODE
TR4	2750024004	MPA68H(K) FIELD EFFECT TRANSISTOR	D5	2760158009	W06A DIODE
TR5	2710102005	2SA1015(Y) TRANSISTOR	D8	2760253001	HZ15-2 DIODE
TR6	2710102005	2SA1015(Y) TRANSISTOR	<b>RESISTORS</b>		
TR7	2710102005	2SA1015(Y) TRANSISTOR	R1	2410362006	100 kohm ±5% ¼W FIXED CARBON FILM
TR8	2710102005	2SA1015(Y) TRANSISTOR	R2	2410362006	100 kohm ±5% ¼W FIXED CARBON FILM
TR9	2730198002	2SC1815(Y) TRANSISTOR	R3	2410306004	470 ohm ±5% ¼W FIXED CARBON FILM
TR10	2730198002	2SC1815(Y) TRANSISTOR	R4	2410306004	470 ohm ±5% ¼W FIXED CARBON FILM
TR11	2750018010	2SK30A(O) FIELD EFFECT TRANSISTOR	R5	2412012040	10 kohm ±2% ¼W FIXED CARBON FILM
TR12	2730212001	2SC2655(Y) TRANSISTOR	R6	2412012040	10 kohm ±2% ¼W FIXED CARBON FILM
TR13	2730198031	2SC1815(BL)/(GR) TRANSISTOR	R7	2412012040	10 kohm ±2% ¼W FIXED CARBON FILM
TR14	2710102005	2SA1015(Y) TRANSISTOR	R8	2412012040	10 kohm ±2% ¼W FIXED CARBON FILM
TR15	2750018010	2SK30A(O) FIELD EFFECT TRANSISTOR	R9	2410289008	910 ohm ±5% ¼W FIXED CARBON FILM
TR16	2710117003	2SA1020(Y) TRANSISTOR	R10	2410289008	910 ohm ±5% ¼W FIXED CARBON FILM
TR17	2730111021	2SC1213(C) TRANSISTOR	R11	2410342000	15 kohm ±5% ¼W FIXED CARBON FILM
TR18	2730177007	2SC1626(Y) TRANSISTOR	R12	2410342000	15 kohm ±5% ¼W FIXED CARBON FILM

(Con.)

Ref. No.	Part No.	Part Name & Description		Ref. No.	Part No.	Part Name & Description	
R13	2410342000	15 kohm	±5% ¼W FIXED CARBON FILM	C6	2544034006	4.7 µF	35V FIXED ELECTROLYTIC
R14	2410342000	15 kohm	±5% ¼W FIXED CARBON FILM	C7	2533629008	120 pF	±5% 50V FIXED CERAMIC
R15	2420203003	10 Mohm	±10% ¼W FIXED CARBON COMPOSIT	C8	2533629008	120 pF	50V FIXED CERAMIC
R16	2420203003	10 Mohm	±10% ¼W FIXED CARBON COMPOSIT	C9	2533623004	68 pF	±5% 50V FIXED CERAMIC
R17	2410342000	15 kohm	±5% ¼W FIXED CARBON FILM	C10	2533623004	68 pF	±5% 50V FIXED CERAMIC
R18	2410336003	8.2 kohm	±5% ¼W FIXED CARBON FILM	C13	2533609002	18 pF	±5% 50V FIXED CERAMIC
R19	2410362006	100 kohm	±5% ¼W FIXED CARBON FILM	C14	2533609002	18 pF	±5% 50V FIXED CERAMIC
R20	2410362006	100 kohm	±5% ¼W FIXED CARBON FILM	C15	2533643000	470 pF	±5% 50V FIXED CERAMIC
R21	2410318005	1.5 kohm	±5% ¼W FIXED CARBON FILM	C16	253364300	470 pF	±5% 50V FIXED CERAMIC
R22	2410318005	1.5 kohm	±5% ¼W FIXED CARBON FILM	C21	2533610004	20 pF	±5% 50V FIXED CERAMIC
R23	2410282005	47 ohm	±5% ¼W FIXED CARBON FILM	C22	2533610004	20 pF	±5% 50V FIXED CERAMIC
R24	2410282005	47 ohm	±5% ¼W FIXED CARBON FILM	C23	2556022006	750 pF	±5% 50V FIXED PLASTIC FILM
R25	2410282005	47 ohm	±5% ¼W FIXED CARBON FILM	C24	2556022006	750 pF	±5% 50V FIXED PLASTIC FILM
R26	2410282005	47 ohm	±5% ¼W FIXED CARBON FILM	C25	2551121038	0.012 µF	±5% 50V FIXED PLASTIC FILM
R27	2410765001	1 Mohm	±5% ¼W FIXED CARBON FILM	C26	2551121038	0.012 µF	±5% 50V FIXED PLASTIC FILM
R28	2410765001	1 Mohm	±5% ¼W FIXED CARBON FILM	C27	2551122037	0.082 µF	±5% 50V FIXED PLASTIC FILM
R29	2410318005	1.5 kohm	±5% ¼W FIXED CARBON FILM	C28	2551122037	0.082 µF	±5% 50V FIXED PLASTIC FILM
R30	2410318005	1.5 kohm	±5% ¼W FIXED CARBON FILM	C29	2533607004	15 pF	±5% 50V FIXED CERAMIC
R31	2410325001	3 kohm	±5% ¼W FIXED CARBON FILM	C30	2533607004	15 pF	±5% 50V FIXED CERAMIC
R32	2410325001	3 kohm	±5% ¼W FIXED CARBON FILM	C31	2533623004	68 pF	±5% 50V FIXED CERAMIC
R33	2410325001	3 kohm	±5% ¼W FIXED CARBON FILM	C32	2533623004	68 pF	±5% 50V FIXED CERAMIC
H35	2410324002	2.7 kohm	±5% ¼W FIXED CARBON FILM	C33	2551120026	0.0015 µF	±5% 50V FIXED PLASTIC FILM
R36	2410324002	2.7 kohm	±5% ¼W FIXED CARBON FILM	C34	2551120026	0.0015 µF	±5% 50V FIXED PLASTIC FILM
R37	2410349003	30 kohm	±5% ¼W FIXED CARBON FILM	C35	2531024003	0.01 µF	+80% -20% 50V FIXED CERAMIC
R38	2410349003	30 kohm	±5% ¼W FIXED CARBON FILM	C37	2551121038	0.012 µF	±5% 50V FIXED PLASTIC
R39	2410349003	30 kohm	±5% ¼W FIXED CARBON FILM	C38	2551121038	0.012 µF	±5% 50V FIXED PLASTIC FILM
R40	2410349003	30 kohm	±5% ¼W FIXED CARBON FILM	C39	2551122079	0.18 µF	±5% 50V FIXED PLASTIC FILM
R41	2410332007	5.6 kohm	±5% ¼W FIXED CARBON FILM	C40	2551122079	0.18 µF	±5% 50V FIXED PLASTIC FILM
R42	2410332007	5.6 kohm	±5% ¼W FIXED CARBON FILM	C42	2531053003	0.01 µF	+100% -0% 500V FIXED CERAMIC
R43	2410314009	1 kohm	±5% ¼W FIXED CARBON FILM	C43	2551084007	0.1 µF	±10% 50V FIXED PLASTIC FILM
R44	2410314009	1 kohm	±5% ¼W FIXED CARBON FILM	C44	2551084007	0.1 µF	±10% 50V FIXED PLASTIC FILM
R45	2410366002	150 kohm	±5% ¼W FIXED CARBON FILM	C45	2544042001	1000 µF	35V FIXED ELECTROLYTIC
R46	2410366002	150 kohm	±5% ¼W FIXED CARBON FILM	C46	2544017007	47 µF	16V FIXED ELECTROLYTIC
R47	2410332007	5.6 kohm	±5% ¼W FIXED CARBON FILM	C47	2544039001	220 µF	35V FIXED ELECTROLYTIC
R48	2410332007	5.6 kohm	±5% ¼W FIXED CARBON FILM	C49	2533611003	22 pF	50V FIXED CERAMIC
R49	2410323003	2.4 kohm	±5% ¼W FIXED CARBON FILM	C50	2533611003	22 pF	50V FIXED CERAMIC
R50	2410323003	2.4 kohm	±5% ¼W FIXED CARBON FILM	<b>OTHER PARTS</b>			
R51	2410358007	68 kohm	±5% ¼W FIXED CARBON FILM		2220443005	P.C. BOARD	
R52	2410358007	68 kohm	±5% ¼W FIXED CARBON FILM		2050112027	2P. CONNECTOR BASE FOR LAMP	
R53	2410298002	220 ohm	±5% ¼W FIXED CARBON FILM		2050112030	3P. CONNECTOR BASE FOR EQ OUT	
R54	2410298002	220 ohm	±5% ¼W FIXED CARBON FILM		2050087039	3P. TERMINAL FOR POWER TRANS.	
R55	2410349003	30 kohm	±5% ¼W FIXED CARBON FILM		2030197004	1P. CONTACT FOR EQ EARTH	
R56	2410349003	30 kohm	±5% ¼W FIXED CARBON FILM		2032067022	2P. CONNECTOR FOR DIRECT	
	2410335004	7.5 kohm	±5% ¼W FIXED CARBON FILM		2030067011	1P. CONNECTOR FOR - B	
R58	2410347005	24 kohm	±5% ¼W FIXED CARBON FILM		2038081002	5P. CONNECTOR CORD FOR HEAD PHONE	
R59	2410338001	10 kohm	±5% ¼W FIXED CARBON FILM		2036078033	4P. CONNECTOR FOR EQ	
R60	2410346006	22 kohm	±5% ¼W FIXED CARBON FILM		2040069009	6P. CONNECTOR FOR PUS-014	
R61	2410342000	15 kohm	±5% ¼W FIXED CARBON FILM		2090008117	JUMPER SHORT LEAD USED-3 P = 12.5 mm	
R62	2410342000	15 kohm	±5% ¼W FIXED CARBON FILM	PL1	3930034004	PILOT LAMP 14V 0.15A	
R63	2410325001	3 kohm	±5% ¼W FIXED CARBON FILM	J1	2048063007	HEAD PHONE JACK WITH SPRING WASHER	
R64	2410325001	3 kohm	±5% ¼W FIXED CARBON FILM		4170021009	RADIATOR	
R65	2440083025	56 ohm	±5% 2W FIXED METAL OXIDE FILM FORMING TYPE		4730354019	TAPPING SCREW(2)3 x 8 FOR TR18 FIXED	
R66	2440021029	22 ohm	±5% 1W FIXED METAL OXIDE FILM FORMING TYPE	VR1	2110229009	VARIABLE RESISTOR 100 kohm FOR BASS	
R67	2410314009	1 kohm	±5% ¼W FIXED CARBON FILM	VR2	2110229009	VARIABLE RESISTOR 100 kohm FOR TREBLE	
<b>CAPACITORS</b>				SW4	2124188000	2P. PUSH SWITCH FOR S. FILTER	
C1	2551120000	0.001 µF	±5% 50V FIXED PLASTIC FILM	SW5	2124188000	2P. PUSH SWITCH FOR LOUD	
C2	2551120000	0.001 µF	±5% 50V FIXED PLASTIC FILM	SW6	2124186002	SLIDE SWITCH (REMOTE) FOR DIRECT	
C3	2561008060	1 µF	±10% 100V FIXED METALIZED		4730354019	TAPPING SCREW(2)3x8 FOR 2P. PUSH SW. FIXED	
C4	2561008060	1 µF	±10% 100V FIXED METALIZED	VR3	2110230001	VARIABLE RESISTOR FOR BALANCE	
C5	2544034006	4.7 µF	35V FIXED ELECTROLYTIC	VR4	2110192000	VARIABLE RESISTOR FOR MAIN VOLUME	

PUS-014B (for 2DX, 2DA, 2DUK, 1DU), PUS-014C (for 1DC)

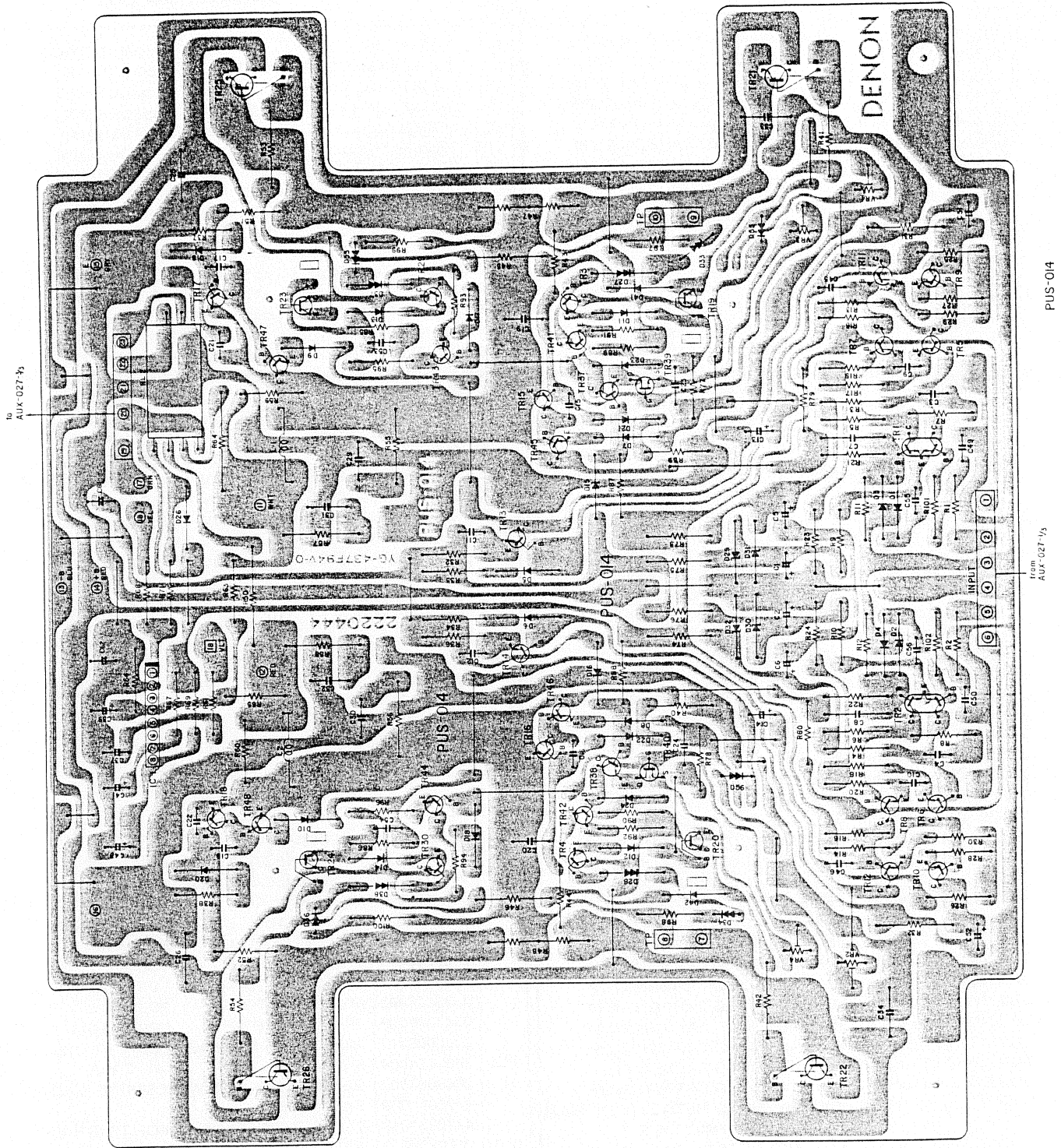

PUS-014C PARTS LIST (for Canada model – 1DC)

Ref. No.	Part No.	Part Name & Descriptions
R67	24410102003	2.2 kohm ±5% 2W FIXED METAL OXIDE FILM

All other parts are the same as PUS-014B.

## PUS-014B PARTS LIST

Ref. No.	Part No.	Part Name & Description	
SEMICONDUCTORS			
IC1	2630102004	HA2002W	INTEGRATED CIRCUIT
TR1	2730181019	2SC1583(G)/(F)	TRANSISTOR
TR2	2730181019	2SC1583(G)/(F)	TRANSISTOR
TR3	2730207003	2SC1845(F)	TRANSISTOR
TR4	2730207003	2SC1845(F)	TRANSISTOR
TR5	2730198002	2SC1815(Y)	TRANSISTOR
TR6	2730198002	2SC1815(Y)	TRANSISTOR
TR7	2730198002	2SC1815(Y)	TRANSISTOR
TR8	2730198002	2SC1815(Y)	TRANSISTOR
TR9	2710108009	2SA905(G)	TRANSISTOR
TR10	2710108009	2SA905(G)	TRANSISTOR
TR11	2710108009	2SA905(G)	TRANSISTOR
TR12	2710108009	2SA905(G)	TRANSISTOR
TR13	2730203007	2SC1915(G)	TRANSISTOR
TR14	2730203007	2SC1915(G)	TRANSISTOR
TR15	2730198002	2SC1815(Y)	TRANSISTOR
TR16	2730198002	2SC1815(Y)	TRANSISTOR
TR17	2710102005	2SA1015(Y)	TRANSISTOR
TR18	2710102005	2SA1015(Y)	TRANSISTOR
TR19	2730226026	2SC2275(Q)/(R)	TRANSISTOR
TR20	2730226026	2SC2275(Q)/(R)	TRANSISTOR
TR21	2730228024	2SC2681(Q)/(R)	TRANSISTOR
TR22	2730228024	2SC2681(Q)/(R)	TRANSISTOR
TR23	2710123026	2SA985(Q)/(R)	TRANSISTOR
TR24	2710123026	2SA985(Q)/(R)	TRANSISTOR
TR25	2710125024	2SA1141(Q)/(R)	TRANSISTOR
TR26	2710125024	2SA1141(Q)/(R)	TRANSISTOR
TR29	2710111009	2SA992(F)	TRANSISTOR
TR30	2710111009	2SA992(F)	TRANSISTOR
TR37	2730207003	2SC1845(F)	TRANSISTOR
TR38	2730207003	2SC1845(F)	TRANSISTOR
TR39	2750020008	2SK163(M)	FIELD EFFECT TRANSISTOR
TR40	2750020008	2SK163(M)	FIELD EFFECT TRANSISTOR
TR41	2710111009	2SA992(F)	TRANSISTOR
TR42	2710111009	2SA992(F)	TRANSISTOR
TR43	2730207003	2SC1845(F)	TRANSISTOR
TR44	2730207003	2SC1845(F)	TRANSISTOR
TR45	2710102005	2SA1015(Y)	TRANSISTOR
TR46	2710102005	2SA1015(Y)	TRANSISTOR
TR47	2730198002	2SC1815(Y)	TRANSISTOR
TR48	2730198002	2SC1815(Y)	TRANSISTOR
D1	2760049008	1S2076	DIODE
	2760049008	1S2076	DIODE
D3	2760049008	1S2076	DIODE
D4	2760049008	1S2076	DIODE
D5	2760171028	HV-23G(YL)	DIODE
D6	2760171028	HV-23G(YL)	DIODE
D7	2760049011	1S2076A	DIODE
D8	2760049011	1S2076A	DIODE
D9	2760049011	1S2076A	DIODE
D10	2760049011	1S2076A	DIODE
D11	2760049011	1S2076A	DIODE
D12	2760049011	1S2076A	DIODE
D13	2760049011	1S2076A	DIODE
D14	2760049011	1S2076A	DIODE
D15	2760219003	HZ-15	DIODE
D16	2760219003	HZ-15	DIODE
D17	2760049011	1S2076A	DIODE
D18	2760049011	1S2076A	DIODE
D19	2760049011	1S2076A	DIODE
D20	2760049011	1S2076A	DIODE
D21	2760049011	1S2076A	DIODE
D22	2760049011	1S2076A	DIODE
D23	2760049011	1S2076A	DIODE
D24	2760049011	1S2076A	DIODE
D26	2760237001	RV06	DIODE
D27	2760200009	MV-11	DIODE

Ref. No.	Part No.	Part Name & Description			
D28	2760200009	MV-11			DIODE
D33	2760217005	STV-2H			DIODE
D34	2760217005	STV-2H			DIODE
D35	2760217005	STV-2H			DIODE
D36	2760217005	STV-2H			DIODE
D37	2760200009	MV-11			DIODE
D38	2760200009	MV-11			DIODE
D55	2760290006	STV-4H(GR)			DIODE
D56	2760290006	STV-4H(GR)			DIODE
RESISTORS					
R1	2410301009	300 ohm	±5%	¼W	FIXED CARBON FILM
R2	2410301009	300 ohm	±5%	¼W	FIXED CARBON FILM
R3	2412012095	2.2 kohm	±2%	¼W	FIXED CARBON FILM
R4	2412012095	2.2 kohm	±2%	¼W	FIXED CARBON FILM
R5	2412012095	2.2 kohm	±2%	¼W	FIXED CARBON FILM
R6	2412012095	2.2 kohm	±2%	¼W	FIXED CARBON FILM
R7	2410288009	82 ohm	±5%	¼W	FIXED CARBON FILM
R8	2410288009	82 ohm	±5%	¼W	FIXED CARBON FILM
R9	2410340002	12 kohm	±5%	¼W	FIXED CARBON FILM
R10	2410340002	12 kohm	±5%	¼W	FIXED CARBON FILM
R11	2410304006	390 ohm	±5%	¼W	FIXED CARBON FILM
R12	2410304006	390 ohm	±5%	¼W	FIXED CARBON FILM
R13	2410302008	330 ohm	±5%	¼W	FIXED CARBON FILM
R14	2410302008	330 ohm	±5%	¼W	FIXED CARBON FILM
R15	2410302008	330 ohm	±5%	¼W	FIXED CARBON FILM
R16	2410302008	330 ohm	±5%	¼W	FIXED CARBON FILM
R17	2410283004	51 ohm	±5%	¼W	FIXED CARBON FILM
R18	2410283004	51 ohm	±5%	¼W	FIXED CARBON FILM
R19	2410283004	51 ohm	±5%	¼W	FIXED CARBON FILM
R20	2410283004	51 ohm	±5%	¼W	FIXED CARBON FILM
R21	2410336003	8.2 kohm	±5%	¼W	FIXED CARBON FILM
R22	2410336003	8.2 kohm	±5%	¼W	FIXED CARBON FILM
R23	2410193000	2.2 kohm	±5%	¼W	FIXED CARBON FILM
R24	2410193000	2.2 kohm	±5%	¼W	FIXED CARBON FILM
R25	2410282005	47 ohm	±5%	¼W	FIXED CARBON FILM
R26	2410282005	47 ohm	±5%	¼W	FIXED CARBON FILM
R27	2410266005	10 ohm	±5%	¼W	FIXED CARBON FILM
R28	2410266005	10 ohm	±5%	¼W	FIXED CARBON FILM
R29	2410266005	10 ohm	±5%	¼W	FIXED CARBON FILM
R30	2410266005	10 ohm	±5%	¼W	FIXED CARBON FILM
R31	2440049027	4.7 kohm	±5%	1W	FIXED METAL OXIDE FILM FORMING TYPE
R32	2440049027	4.7 kohm	±5%	1W	FIXED METAL OXIDE FILM FORMING TYPE
R33	2410290000	100 ohm	±5%	¼W	FIXED CARBON FILM
R34	2410290000	100 ohm	±5%	¼W	FIXED CARBON FILM
R35	2410290000	100 ohm	±5%	¼W	FIXED CARBON FILM
R36	2410290000	100 ohm	±5%	¼W	FIXED CARBON FILM
R37	2410328008	3.9 kohm	±5%	¼W	FIXED CARBON FILM
R38	2410328008	3.9 kohm	±5%	¼W	FIXED CARBON FILM
R39	2410328008	3.9 kohm	±5%	¼W	FIXED CARBON FILM
R40	2410328008	3.9 kohm	±5%	¼W	FIXED CARBON FILM
R41	2440013024	4.7 kohm	±5%	1W	FIXED METAL OXIDE FILM FORMING TYPE
R42	2440013024	4.7 kohm	±5%	1W	FIXED METAL OXIDE FILM FORMING TYPE
R43	2410309001	620 ohm	±5%	¼W	FIXED CARBON FILM
R44	2410309001	620 ohm	±5%	¼W	FIXED CARBON FILM
R45	2440027023	68 ohm	±5%	1W	FIXED METAL OXIDE FILM FORMING TYPE
R46	2440027023	68 ohm	±5%	1W	FIXED METAL OXIDE FILM FORMING TYPE
R47	2432026016	0.33/0.33 ohm±10%		3.15W	FIXED WIRE WOUND
R48	2432026016	0.33/0.33 ohm±10%		3.15W	FIXED WIRE WOUND

(Con.)

Ref. No.	Part No.	Part Name & Descriptions		Ref. No.	Part No.	Part Name & Description	
R49	2440087021	120 ohm	±5% 2W	C12	2533627000	100 pF	±5% 50V
R50	2440087021	120 ohm	±5% 2W	C13	2544060025	1 μF	100V
R51	2410309001	620 ohm	±5% ¼W	C14	2544060025	1 μF	100V
R52	2410309001	620 ohm	±5% ¼W	C15	2531008003	0.0047 μF ±10%	50V
R53	2440013024	4.7 ohm	±5% 1W	C16	2531008003	0.0047 μF ±10%	50V
R54	2440013024	4.7 ohm	±5% 1W	C17	2531008003	0.0047 μF ±10%	50V
R55	2440022028	27 ohm	±5% 1W	C18	2531008003	0.0047 μF ±10%	50V
R56	2440022028	27 ohm	±5% 1W	C19	2551068007	0.0047 μF ±10%	50V
R57	2440017020	10 ohm	±5% 1W	C20	2551068007	0.0047 μF ±10%	50V
R58	2440017020	10 ohm	±5% 1W	C21	2551068007	0.0047 μF ±10%	50V
R59	2410282005	47 ohm	±5% ¼W	C22	2551068007	0.0047 μF ±10%	50V
R60	2410282005	47 ohm	±5% ¼W	C23	2551084007	0.1 μF ±10%	50V
R61	2410330009	4.7 kohm	±5% ¼W	C24	2551084007	0.1 μF ±10%	50V
R63	2410351004	36 kohm	±5% ¼W	C25	2531053003	0.01 μF +10% -0%	500V
R64	2410338001	10 kohm	±5% ¼W	C26	2531053003	0.01 μF +10% -0%	500V
R65	2410351004	36 kohm	±5% ¼W	C29	2551072006	0.01 μF ±10%	50V
*R67	2410192001	2 kohm	±5% ½W	C30	2551072006	0.01 μF ±10%	50V
R68	2410290000	100 ohm	±5% ¼W	C31	2551076002	0.022 μF ±10%	50V
R69	2410769007	1.5 Mohm	±5% ¼W	C32	2551076002	0.022 μF ±10%	50V
R71	2410191002	1.8 kohm	±5% ½W	C33	2531053003	0.01 μF +10% -0%	500V
R73	2410332007	5.6 kohm	±5% ¼W	C34	2531053003	0.01 μF +10% -0%	500V
R74	2410332007	5.6 kohm	±5% ¼W	C37	2544066003	2.2 μF	50V
R75	2410332007	5.6 kohm	±5% ¼W	C39	2544004007	220 μF	6.3V
R76	2410332007	5.6 kohm	±5% ¼W	C41	2544035005	10 μF	35V
R77	2410314009	1 kohm	±5% ¼W	C43	2549015017	47 μF	±10% 10V
R78	2410314009	1 kohm	±5% ¼W	C45	2533596005	3 pF	±0.25% 50V
R79	2420203003	10 Mohm	±5% ¼W	C46	2533596005	3 pF	±0.25% 50V
R80	2420203003	10 Mohm	±5% ¼W	C49	2533627000	100 pF	±5% 50V
R85	2410314009	1 kohm	±5% ¼W	C50	2533627000	100 pF	±5% 50V
R86	2410314009	1 kohm	±5% ¼W	C51	2544060025	1 μF	100V
R87	2410362006	100 kohm	±5% ¼W	C52	2544060025	1 μF	100V
R88	2410362006	100 kohm	±5% ¼W	C53	2533627000	100 pF	±5% 50V
R89	2410314009	1 kohm	±5% ¼W	C54	2533627000	100 pF	±5% 50V
R90	2410314009	1 kohm	±5% ¼W	C55	2531003008	680 pF	±10% 50V
R91	2410314009	1 kohm	±5% ¼W	C56	2531003008	680 pF	±10% 50V
R92	2410314009	1 kohm	±5% ¼W	C61	2544059036	4.7 μF	6.3V
R93	2410314009	1 kohm	±5% ¼W	C62	2544059036	4.7 μF	6.3V
R94	2410314009	1 kohm	±5% ¼W	<b>OTHER PARTS</b>			
R95	2410314009	1 kohm	±5% ¼W		2220444101	P.C.BOARD	
R96	2410314009	1 kohm	±5% ¼W		2050112056	5P. CONNECTOR BASE	
R97	2410274000	22 ohm	±5% ¼W		2050112069	6P. CONNECTOR BASE	
R98	2410274000	22 ohm	±5% ¼W		2050087026	2P. TERMINAL	
R99	2410274000	22 ohm	±5% ¼W		2090008117	JUMPER SHORT LEAD USED-12 P = 12.5 mm	
R100	2410274000	22 ohm	±5% ¼W		2090008146	JUMPER SHORT LEAD USED-3 P = 5 mm	
R101	2410289008	91 ohm	±5% ¼W		2090008162	JUMPER SHORT LEAD USED-6 P = 20 mm	
R102	2410289008	91 ohm	±5% ¼W		209008104	JUMPER SHORT LEAD USED-5	
<b>CAPACITORS</b>				VR1	EP-5462H1	VARIABLE RESISTOR 100 ohm	
C1	2544035005	10 μF	±5% 35V	VR2	EP-5462H1	VARIABLE RESISTOR 100 ohm	
C2	2544035005	10 μF	±5% 35V	VR3	EP-5462H11	VARIABLE RESISTOR 4.7 kohm	
C3	2551120084	0.0047 μF	±5% 50V	VR4	EP-5462H11	VARIABLE RESISTOR 4.7 kohm	
C4	2551120084	0.0047 μF	±5% 50V	RL2	2140034002	REED RELAY 2 CIRCUIT DC 24 V	
C5	2544035005	10 μF	±5% 35V		EP-6071	BASE PIN FOR - B	
C6	2544035005	10 μF	±5% 35V		4170021009	RADIATOR	
C7	2533603008	10 pF	±0.5PF 50V		4730354019	TAPPING SCREW(2) 3 x 8	
C8	2533603008	10 pF	±0.5PF 50V		4150137007	PLAIN WASHER	
C9	2533615009	33 pF	±5% 50V	L1	2320017001	INDUCTOR (1 μH)	
C10	2533615009	33 pF	±5% 50V	L2	2320017001	INDUCTOR (1 μH)	
C11	2533627000	100 pF	±5% 50V		2030069019	1P. CONNECTOR FOR L OUT	
					2030196018	1P CONNECTOR FOR R OUT	
					2040059022	6P. CONNECTOR CORD FOR RELAY	
					4170115009	POWER RADIATOR	
					4700010008	CROSS PAN SCREW WITH S. WASHER 3 x 8	
					4700012006	CROSS PAN SCREW WITH S. WASHER 3 x 12	
					4150068008	INSULATING SHEET (YD-20C)	
					4751003006	3 WASHER	

SUX-023B (for 2DX, 2DA, 2DUK), SUX-023C (for 1DC), SUX-023D (for 1DU).

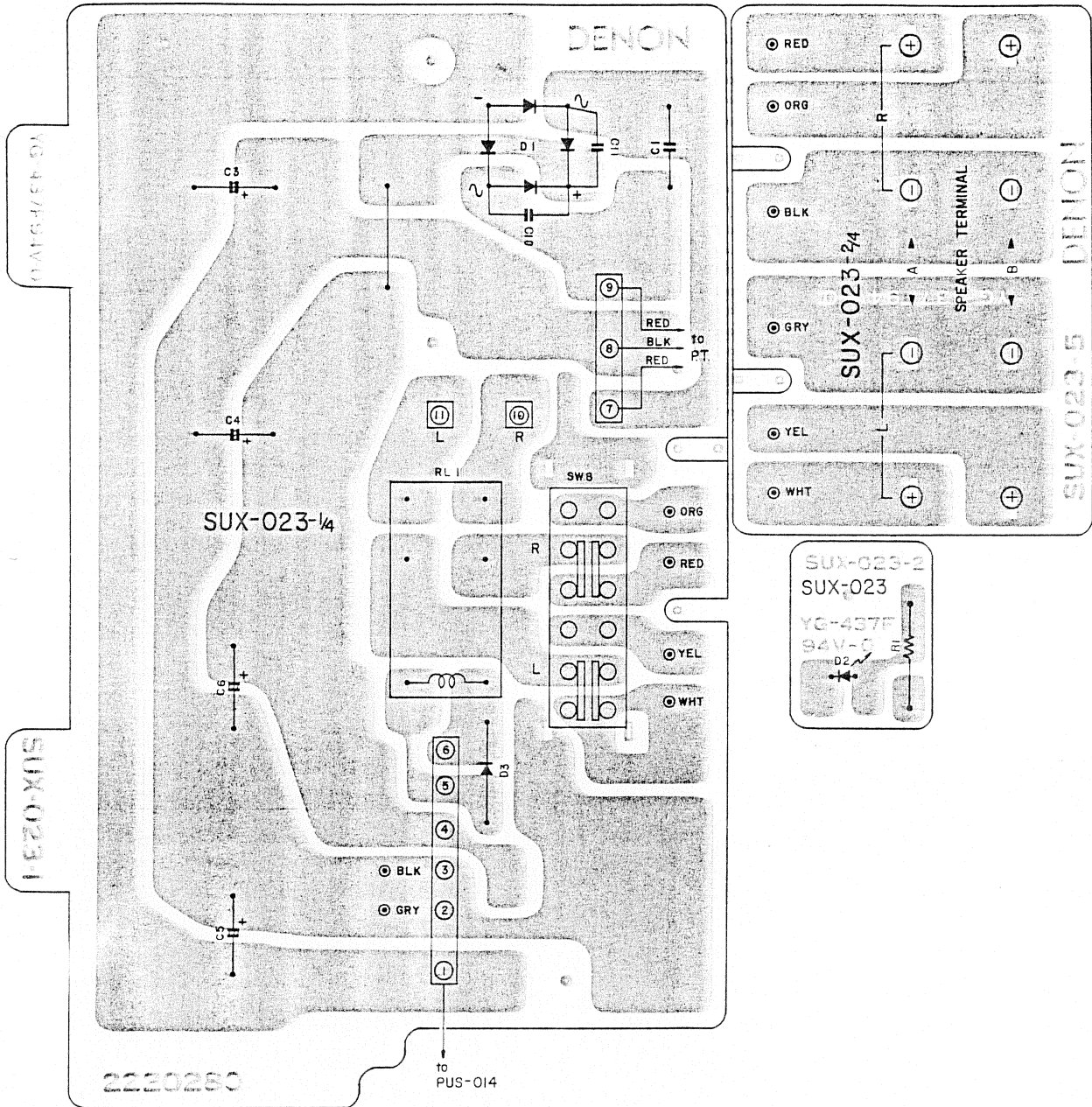

SUX-023B PARTS LIST

Ref. No.	Part No.	Part Name & Descriptions	Ref. No.	Part No.	Part Name & Description
<b>SEMICONDUCTORS</b>			<b>OTHER PARTS</b>		
D1	2760233005	M4C-51 DIODE		2220280103	P.W. BOARD
D2	3939032007	TLR206 LIGHT EMITTING DIODE		2050075038	3P. TERMINAL
D3	2760049011	1S2076A DIODE		2050112069	6P. CONNECTOR BASE
<b>RESISTORS</b>				2090008117	JUMPER SHORT LEAD USED-1 P = 12.5 mm
R1	2410302008	330 ohm ±5% ¼W FIXED CARBON FILM		EP-6071	BASE PIN
<b>CAPACITORS</b>				205007004	8P. TERMINAL
C1	2531053003	0.01 μF +100% -0% 500V FIXED CERAMIC	RL1	2140037009	RELAY
C3	2546048003	4700 μF ±20% 63V FIXED ELECTROLYTIC	SW8	2124189009	SLIDE SWITCH (REMOTE)
C4	2546048003	4700 μF ±20% 63V FIXED ELECTROLYTIC		2032067019	2P. CONNECTOR
C5	2546048003	4700 μF ±20% 63V FIXED ELECTROLYTIC			
C6	2546048003	4700 μF ±20% 63V FIXED ELECTROLYTIC			

# SCHEMATIC CIRCUIT DIAGRAM (FOR 2DX)

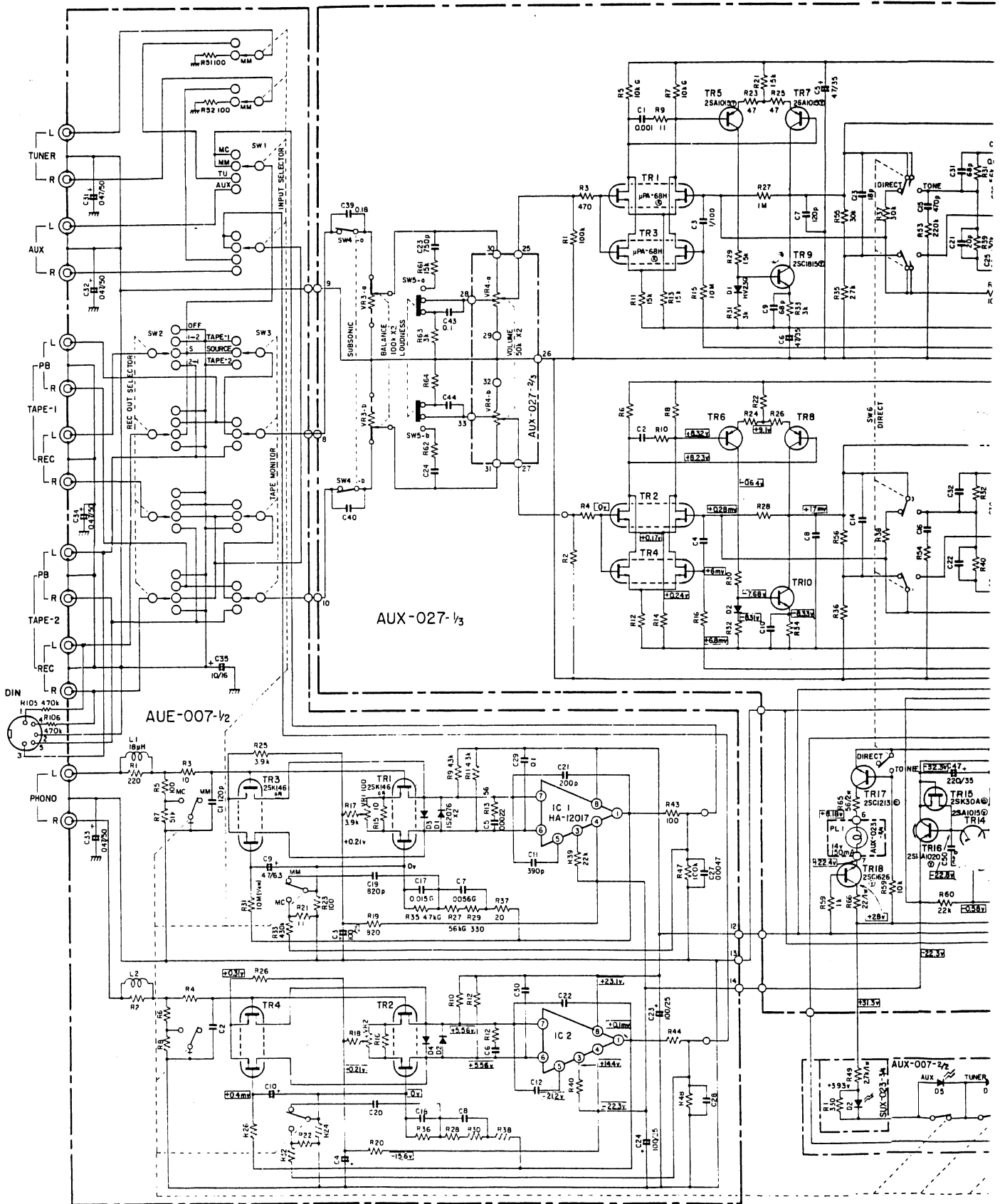



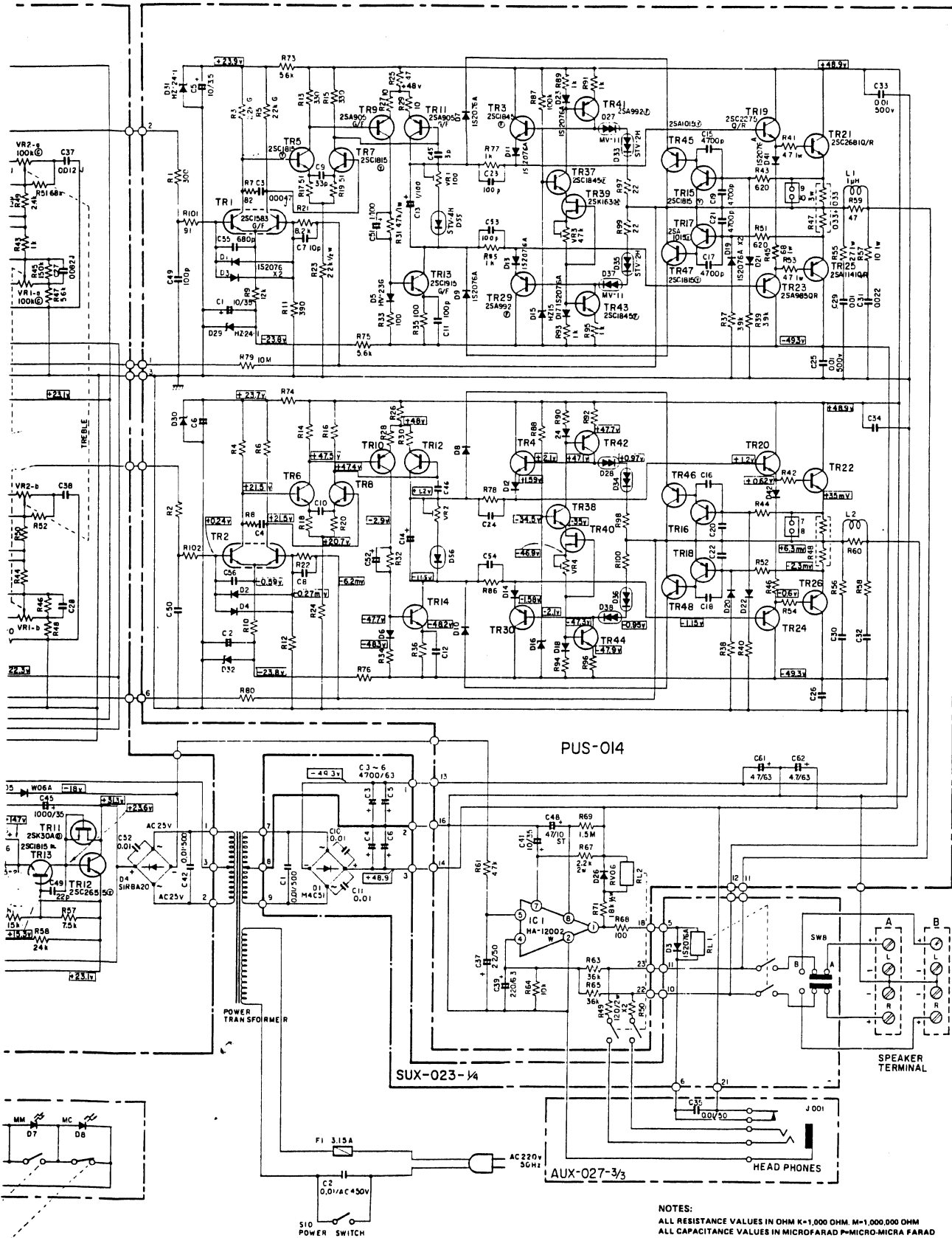

NOTES:  
ALL RESISTANCE VALUES IN OHM K=1,000 OHM M=1,000,000 OHM  
ALL CAPACITANCE VALUES IN MICROFARAD P=MICRO-MICRA FARAD  
EVERY VOLTAGES AND CURRENTS IS MEASURED AT NO SIGNAL INPUT CONDITION  
CIRCUITS AND PARTS ARE SUBJECT TO CHANGE WITHOUT PRIOR NOTICE.

**SCHEMATIC CIRCUIT DIAGRAM (POWER SUPPLY)**

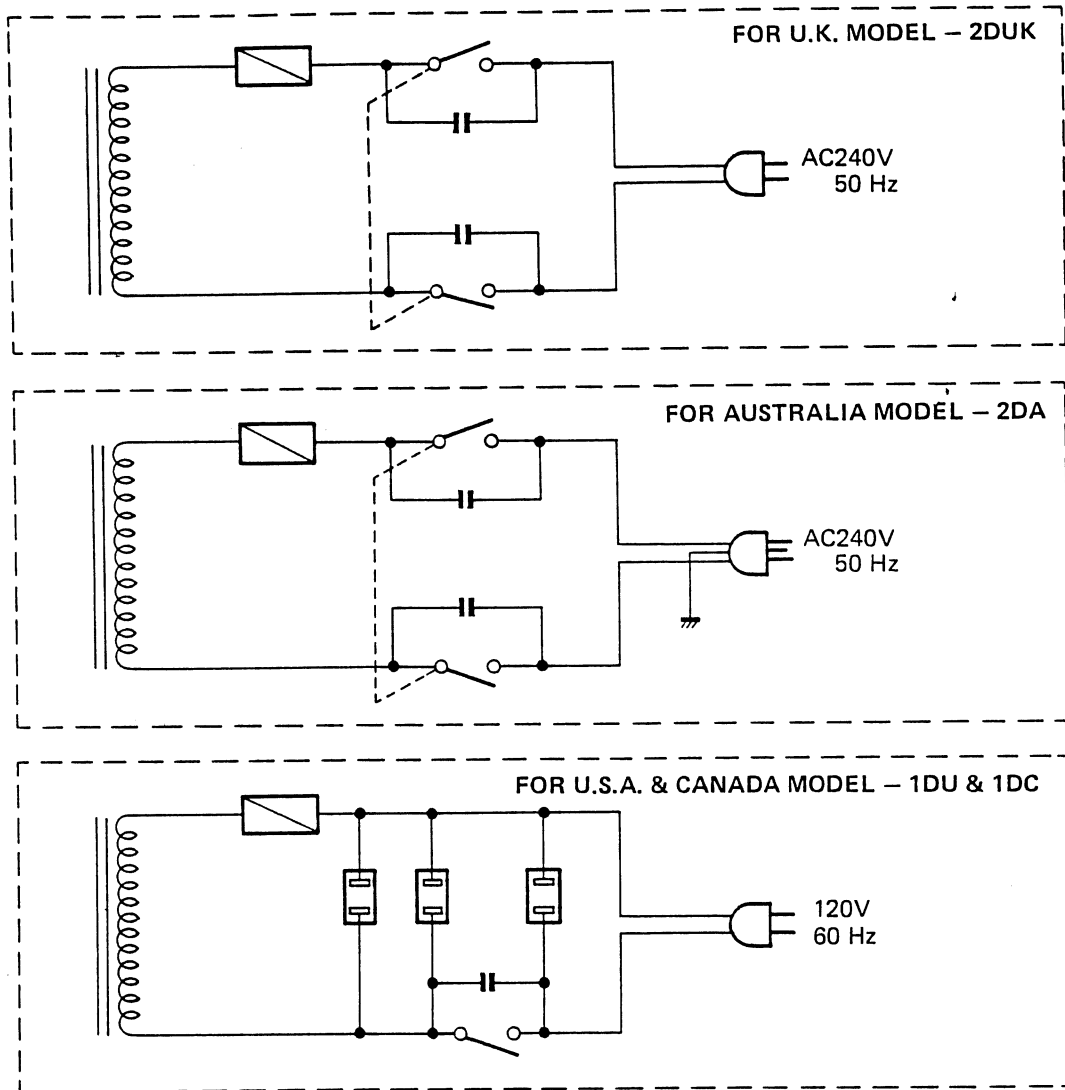

**SUX-023C PARTS LIST (for Canada model - 1DC)**

Ref. No.	Part No.	Part Name & Descriptions
<b>CAPACITORS</b>		
C2	2568019010	0.47 $\mu$ F $\pm$ 20% 125V FIXED METALIZED
C10	2531053003	0.01 $\mu$ F $\begin{smallmatrix} +100\% \\ -0\% \end{smallmatrix}$ 500V FIXED CERAMIC
C11	2531053003	0.01 $\mu$ F $\begin{smallmatrix} +100\% \\ -0\% \end{smallmatrix}$ 500V FIXED CERAMIC
<b>OTHER PARTS</b>		
F1	EP-5870 2061023082 EP-5667H1	FUSE HOLDER FUSE 6.3A UL WRAPPING PIN USED-3
SW10	2124049097	PUSH SWITCH

**SUX-023D PARTS LIST (for U.S.A. model - 1DU)**

Ref. No.	Part No.	Part Name & Descriptions
<b>CAPACITORS</b>		
C2	2568019010	0.47 $\mu$ F $\pm$ 20% 125V FIXED METALIZED
C10	2531053003	0.01 $\mu$ F $\begin{smallmatrix} +100\% \\ -0\% \end{smallmatrix}$ 500V FIXED CERAMIC
C11	2531053003	0.01 $\mu$ F $\begin{smallmatrix} +100\% \\ -0\% \end{smallmatrix}$ 500V FIXED CERAMIC
<b>OTHER PARTS</b>		
SW10	EP-5870 2124049097	FUSE HOLDER PUSH SWITCH

all other parts are the same as SUX-023B.

# WIRING DIAGRAM

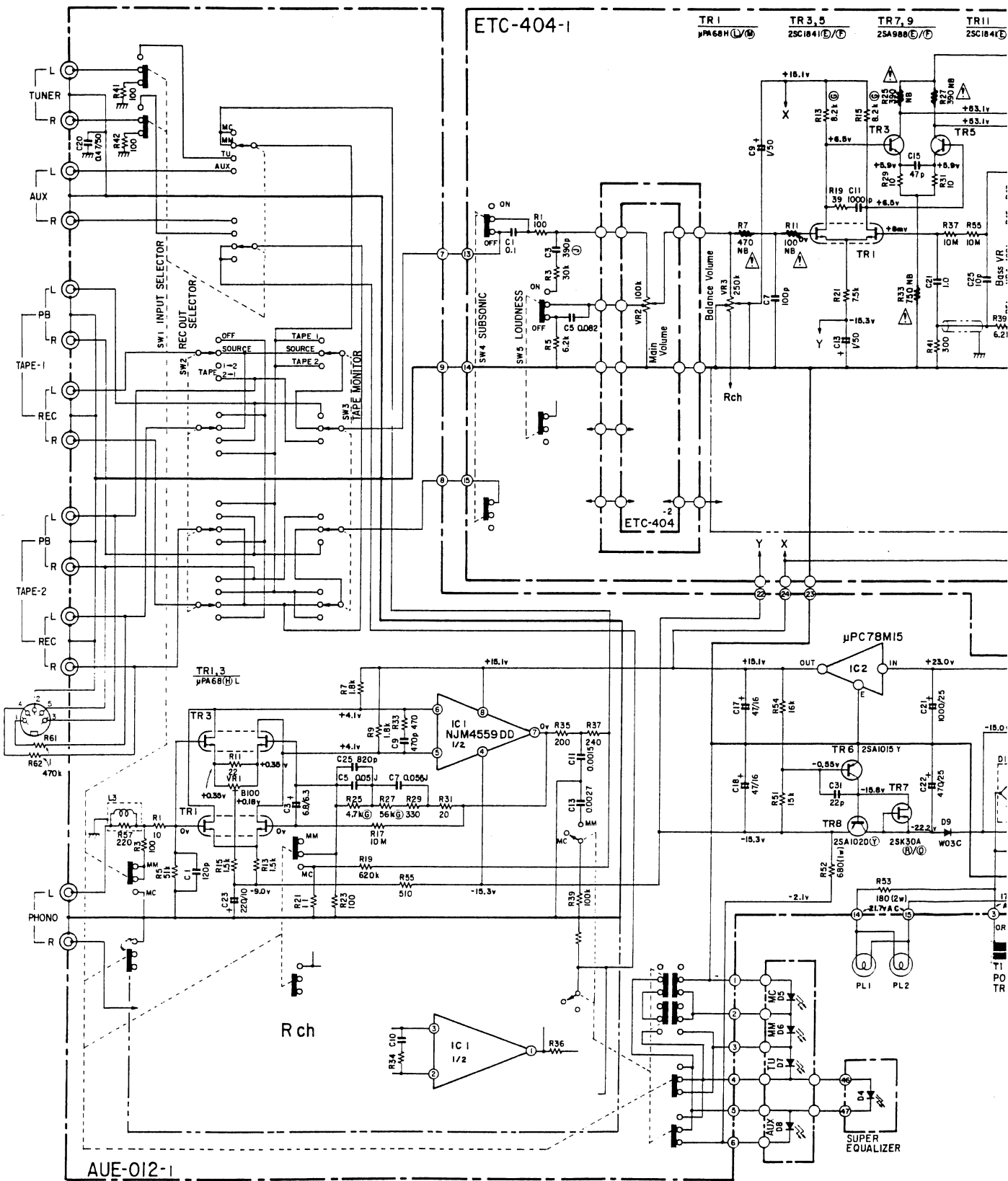

# DENON

## EXPLODED VIEW OF PARTS LIST

⚠  Means important safety item, which must be replaced, when necessary, by a part specified or meeting the specification by the manufacturer.

Ref. No.	Part No.	Part Name & Descriptions	Ref. No.	Part No.	Part Name & Descriptions
*1	1050373016	BACK PANEL	44	4630220007	SPRING
2	2033910000	AC OUTLET	45	1250009209	WASHER
3	4770064107	FIXING SCREW	46	1430180104	LENS
4	2050071016	TERMINAL	47	4120789100	LED HOLDER BRACKET
5	4770018001	WASHER	*48	AUE0012E6	EQ. LED UNIT
<del>7</del>	<del>2082619008</del>	<del>ACCORD</del>	*49	AUE0012E7	TONE LED UNIT
<del>7</del>	<del>MD-3802</del>	<del>BUSHING</del>	*50	AUE0012E3	INPUT LED UNIT
8	2050070004	8P. TERMINAL	51	4730304014	TAPPING SCREW (1)3x8
9	4110216706	SIDE CHASSIS	52	1460338104	ESC. PLATE (L)
10	4110246103	TRANS CHASSIS	53	1460339103	ESC. PLATE (R)
11	4120780206	RADIATOR BRACKET	54	1020107005	TOP COVER
12	4730354019	TAPPING SCREW (2)3x8	55	1040034006	STOPPER
13	4701300000	POWER RADIATOR	56	1220069008	SPACER
14	2730243025	TRANSISTOR 2SC2838(O)&(Y)	57	4734801005	TAPPING SCREW TRUS 4x8
15	2710143022	TRANSISTOR 2SA1187(O)&(Y)	58	1120321011	KNOB ASS. (A)
16	-	-	59	1120320009	KNOB ASS. (B)
17	4700012022	CROSS PAN SCREW WITH S. WASHER 3x12	60	1120265203	KNOB
18	4120781108	FRONT CHASSIS	61	4730455015	TAPPING SCREW (2)4x10
<del>19</del>	<del>2124263019</del>	<del>PUSH SWITCH</del>	62	4700026005	TAPPING SCREW (1) WITH WASHER 3x8
<del>20</del>	<del>2568019007</del>	<del>METALIZED CAPACITOR 0.01uF/250V</del>	63	EP-4772	CORD HOLDER
21	4700009006	CROSS PAN SCREW WITH S. WASHER 3x6	64	4610155008	BLIND
*22	AUE0012E5	HEADPHONE JACK UNIT	65	4120785007	CONDENSER BRACKET
23	-	φ12 Nut	66	1250004020	SPACER
*24	AUE0012E2	SPEAKER SWITCH UNIT	67	1130196003	PUSH KNOB ASS.
25	3930059005	PILOT LAMP 28V 40mA	68	1130196016	PUSH KNOB ASS.
26	2120169007	ROTARY REMOTE (A) FOR T/M	*69	AUE0012E8	5P. DIN UNIT
27	2120170009	ROTARY REMOTE (B) FOR REC OUT	70	-	-
*28	ETC-0404B	TONE & POWER UNIT	71	-	-
29	4610154009	CUSHION	72	4751005004	φ4 WASHER
30	2432029013	WIRE WOUND RESISTOR 0.33 ohm/0.33 ohm 5W	73	4e10160006	WASHER
31	1050325103	BOTTOM COVER	74	SC-1161	TAPPING SCREW
32	1048001002	FOOT	75	4450033005	WIRE CLAMP BOND USED
33	4730455015	TAPPING SCREW (2)4x10	*76	5130270080	FUSE LABEL
*34	AUE0012E	EQ. AMP UNIT	*77	5130398182	SERIAL NO. PLATE
35	EP-6214	CORD HOLDER	*77	4770126016	RIVET
36	4120784008	TRANSISTOR HOLDER BRACKET	<b>PACKING &amp; ACCESSORIES</b>		
37	4430241105	CONNECTING SHAFT	(100)	5040052013	CABINET COVER
38	1220064087	SPACER	(101)	5030262004	CUSHION
<del>39</del>	<del>2335298006</del>	<del>POWER FANS</del>	(102)	5010702092	CARTON
*40	1440737217	FRONT PANEL ASS.	(103)	5110916005	INST. MANUAL
41	1140047317	PANEL BUSH (A)	* (104)	5130364006	CAUTION SHEET
42	1130171222	PUSH KNOB ASS.			
43	1190021008	STOPPER			

The items are the same as those for PMA-540 without \* mark items. Refer to the service manual for PMA-540 as to the common items.

### NIPPON COLUMBIA CO., LTD.

No. 14-14, 4-CHOME AKASAKA,  
MINATO-KU, TOKYO 107, JAPAN  
TEL: 03-584-8111  
TLX: JAPANOLA J22591  
CABLE: NIPPONCOLUMBIA TOKYO