

DENON

Hi-Fi Integrated Stereo Amplifier

SERVICE MANUAL

MODEL PMA-655R

INTEGRATED STEREO AMPLIFIER

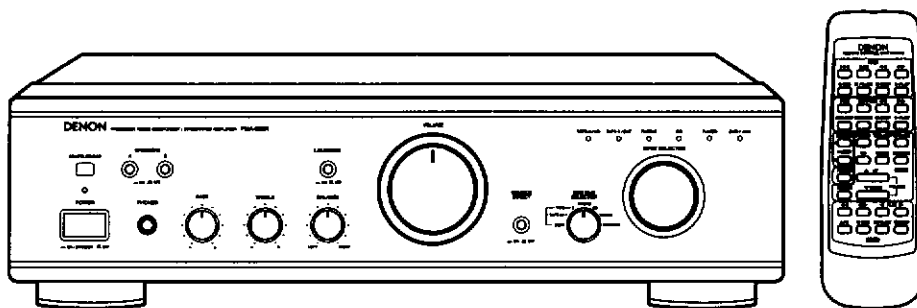

— TABLE OF CONTENTS —

SAFETY PRECAUTIONS	2
SPECIFICATIONS	2
DISASSEMBLY	3,4
BLOCK AND LEVEL DIAGRAM	5
ADJUSTMENT	6
SEMICONDUCTORS	7~10
PRINTED WIRING BOARD	11~13
NOTE FOR PARTS LIST	14
PARTS LIST OF P.W.BOARD	14~17
PARTS LIST OF EXPLODED VIEW	18
EXPLODED VIEW	19
WIRING DIAGRAM	20
SCHEMATIC DIAGRAM	21
PACKING VIEW	23
PARTS LIST OF PACKING & ACCESSORIES	23

● Some illustration using in this service manual is slightly different from the actual set.

NIPPON COLUMBIA CO., LTD.

SAFETY PRECAUTIONS

The following check should be performed for the continued protection of the customer and service technician.

LEAKAGE CURRENT CHECK

Before returning the unit to the customer, make sure you make either (1) a leakage current check or (2) a line to chassis resistance check. If the leakage current exceeds 0.5 milliamps, or if the resistance from chassis to either side of the power cord is less than 460 kohms, the unit is defective.

SPECIFICATIONS

POWER AMPLIFIER SECTION

Rated Output Power:

Both channel driven 8 Ω /ohms Load

50 W + 50 W (20 Hz to 20 kHz, T.H.D. 0.07%)

4 Ω /ohms Load

85 W + 85 W (DIN, 1 kHz, T.H.D. 0.7%)

Total Harmonic Distortion:

0.01%

(-3 dB at rated output, 8 Ω /ohms) (1 kHz)

PRE AMPLIFIER SECTION

Rated Output:

150 mV

(Recout terminal)

Input Sensitivity/Input Impedance:

PHONO:

2.5 mV/47 k Ω /kohms

CD, TUNER, DVD/AUX, TAPE-1/DAT, TAPE-2/MD:

150 mV/47 k Ω /kohms

RIAA Deviation:

PHONO:

20 Hz to 20 kHz \pm 0.5 dB

OVERALL CHARACTERISTICS

SN Ratio (IHF A Network):

PHONO:

86 dB (at 5mV input) (input terminals short-circuited)

SOURCE-DIRECT:

ON

CD, TUNER, DVD/AUX, TAPE-1/DAT, TAPE-2/MD:

107 dB

Tone control Adjustable Range:

BASS:

100 Hz \pm 8 dB

TREBLE:

10 kHz \pm 8 dB

LOUDNESS:

100 Hz +6 dB

10 kHz +6 dB

OTHERS

Power supply:

AC230 V, 50 Hz (Europe, Asia & Hong Kong Models)

AC120 V, 60 Hz (U.S.A., Canada & Taiwan R.O.C. Models)

AC Outlets:

Switched \times 3:

120 W (U.S.A., Canada & Taiwan R.O.C. Models)

100 W (Europe, Asia & Hong Kong Models)

Power Consumption:

185 W (IEC) (Europe, Asia & Hong Kong Models)

3.0 A (U.S.A., Canada & Taiwan R.O.C. Models)

2 W MAX (Standby)

Dimensions:

434 (W) \times 121 (H) \times 338 (D) mm (17-3/32" \times 4-49/64" \times 13-19/64")

Net Mass:

7.0 kg (15 lbs 7 oz)

REMOTE CONTROL UNIT (RC-843)

Remote control system:

Infrared pulse system

Power supply:

3 V DC, Two size R6P ("AA") dry cell batteries

External dimensions:

54 (W) \times 155 (H) \times 29 (D) mm (2-1/8" \times 6-7/64" \times 1-1/64")

Mass:

100 g (Approx. 3.5 oz) (including batteries)

* Maximum dimensions include controls, jacks, and covers.

(W) = width, (H) = height, (D) = depth

* For improvement purposes, specifications and functions are subject to change without advanced notice.

DISASSEMBLY

(Follow in the reverse order when reassembling)

Top Cover

Remove 4 screws ① on both sides, 3 screws ② on the rear, then detach the Top Cover.

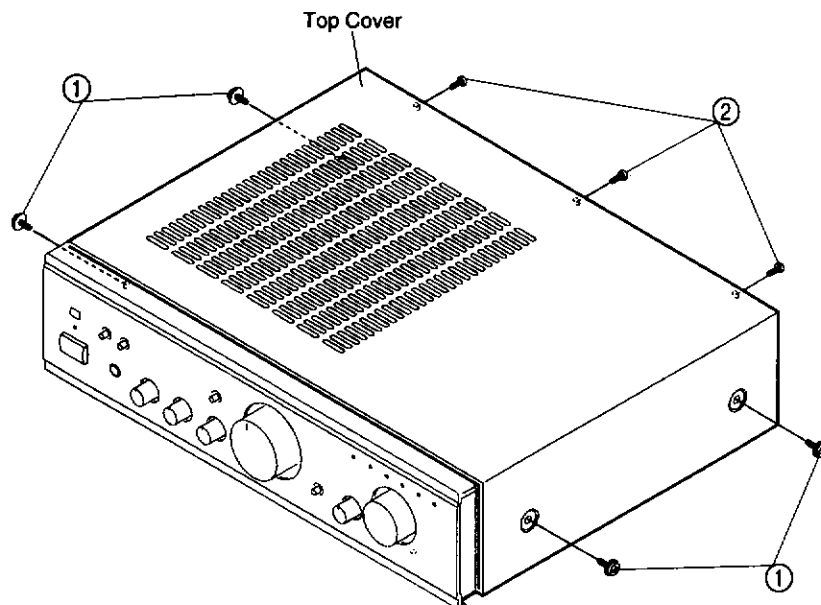

Front Panel

Remove 6 screws ③, 1 screw ④ on upper and lower edges of the Front Panel, then detach it.

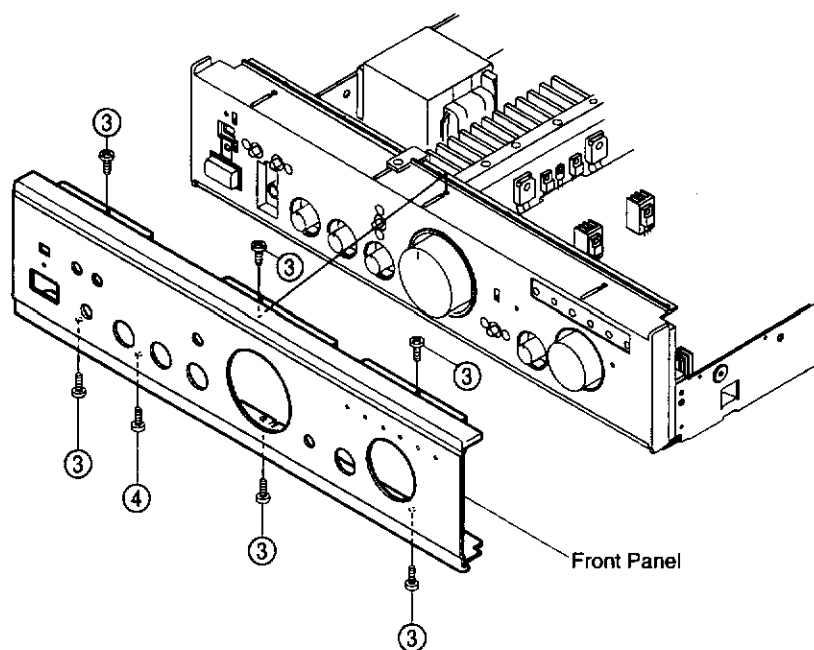

Inner Panel

1. Take off 6 knobs, 6 nuts, and 1 hold plate.
2. Remove 6 screws (5) fixing each P.W.B.
3. Remove 1 screw (6) and 2 screws (7).

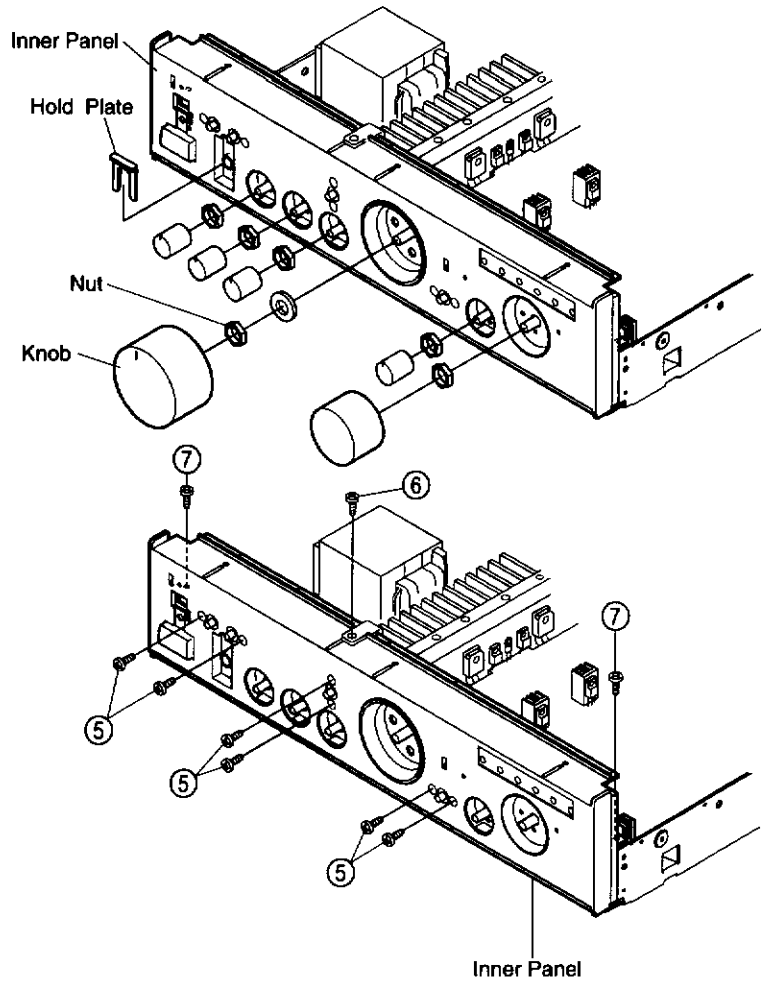

Main P.W.B. and Heat Sink

1. Remove 2 screws (8) on the bottom.
2. Remove 1 screw (9), 8 screws (10) on the rear, then detach the Main P.W.B. and Heat Sink in the arrow direction.

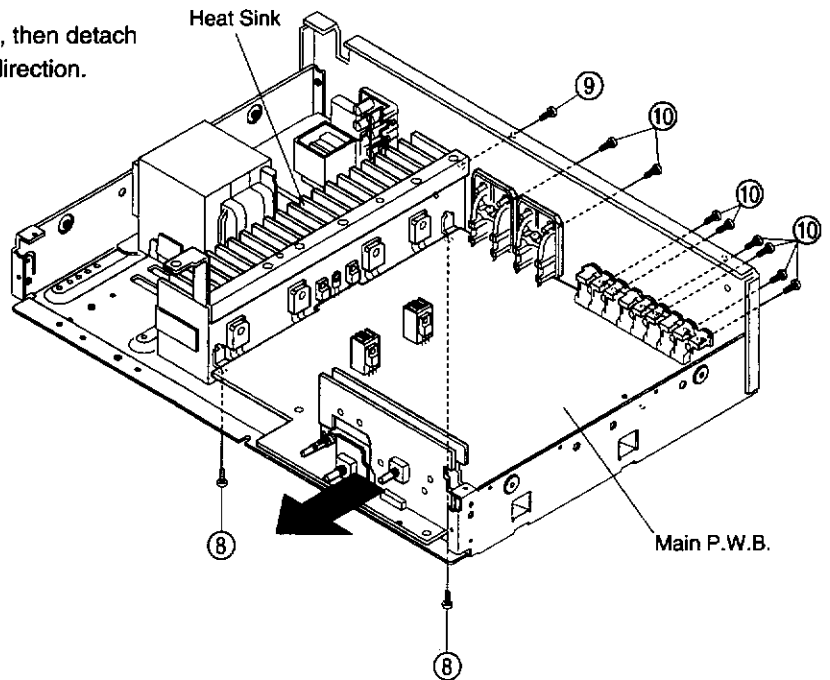

BLOCK AND LEVEL DIAGRAM

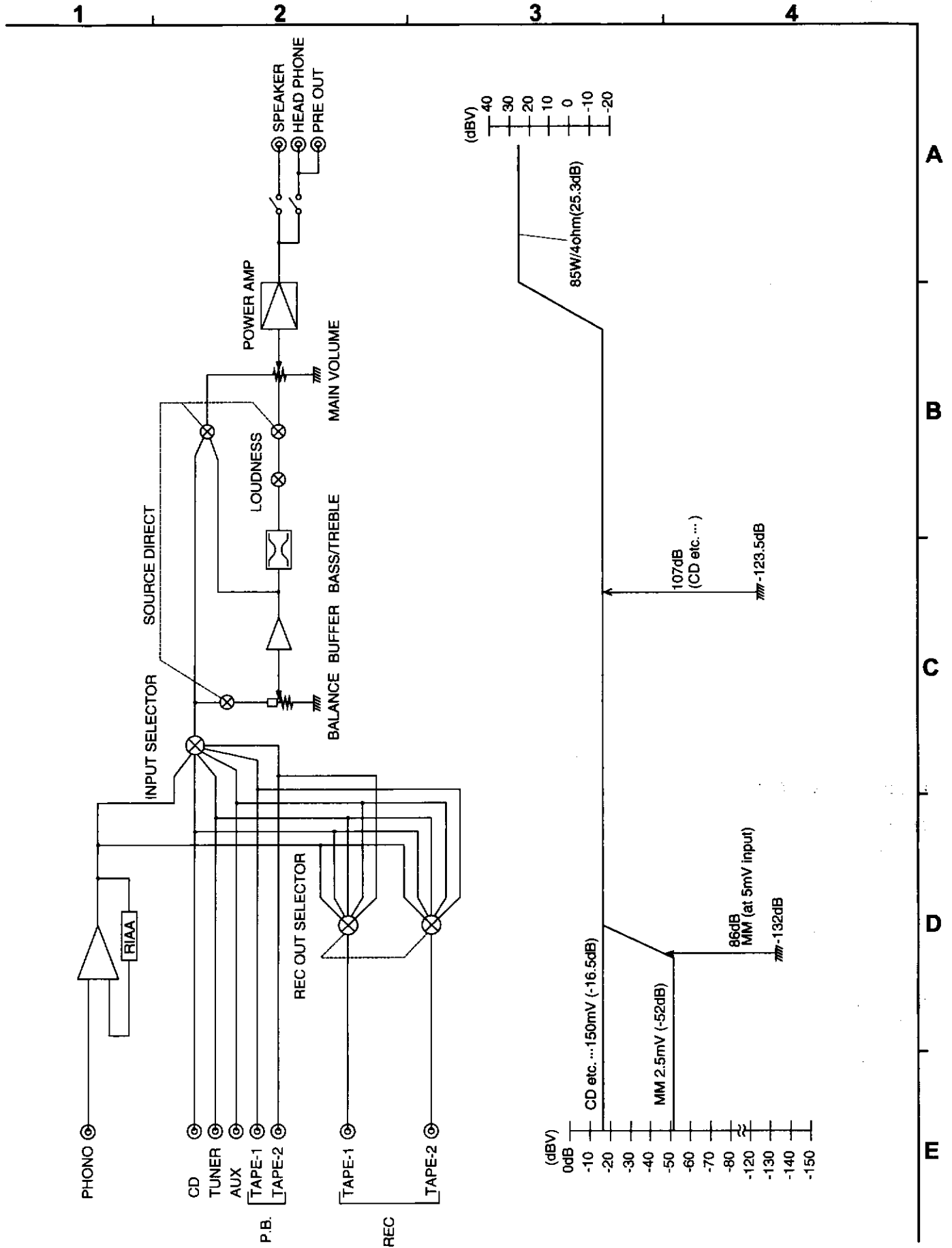

ADJUSTMENT

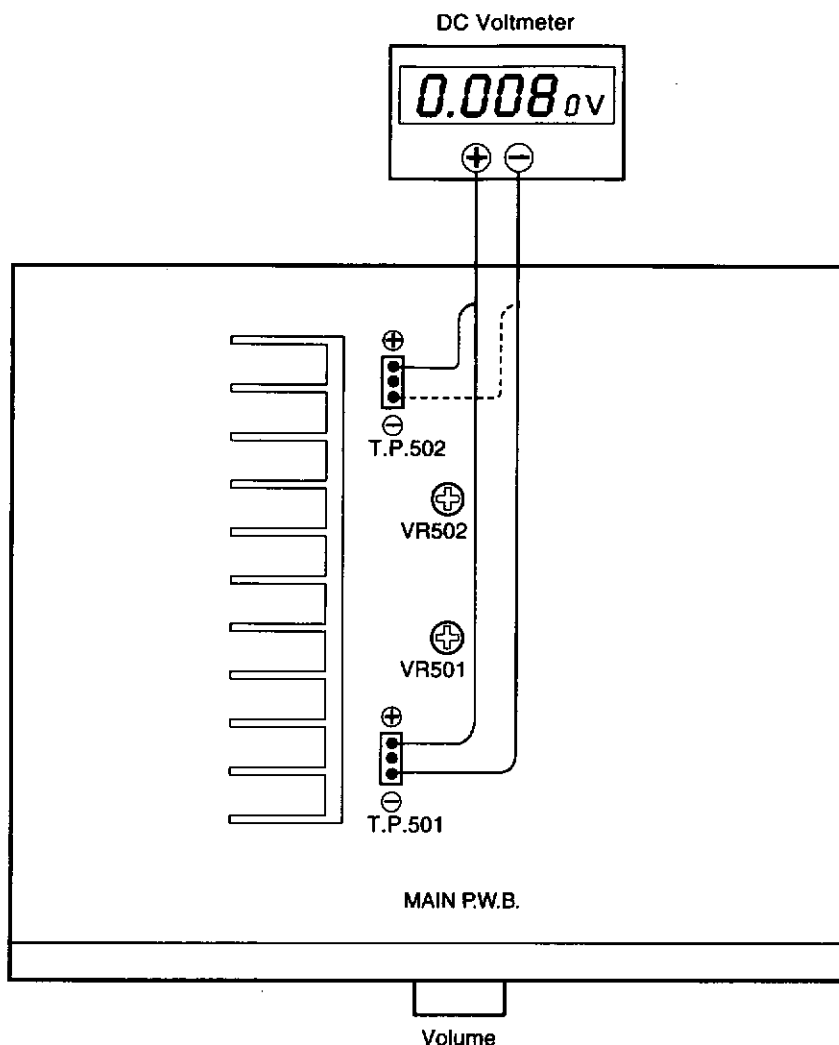

IDLING CURRENT

● Setup

- Place the unit at an ordinary position avoiding direct air flow from an air-conditioner or fan. Do the adjustment at a temperature between 15 °C (59 °F) and 30 °C (86 °F).
- Set control as follows.

POWER switch	→	OFF (■)
VOLUME control	→	fully counterclockwise (⤵ min.)
SPEAKER terminals	→	open: do not connect the speakers, dummy load etc.

● Adjustment

- Remove top cover. And then connect DC voltmeter to the test points TP501 and TP502 of MAIN P.W.B.
- Connect power cord to AC230V (218 ~ 242V) wall outlet, and turn POWER switch "ON" (■).
- Right after power on, adjust VR501 and VR502 so that the DC voltmeter reads $10 \pm 1\text{mV}$.
- Then after 2 minutes warmup adjust VR501 and VR502 so that the DC voltmeter reads $10 \pm 1\text{mV}$.
- And after 10 minutes warmup adjust VR501 and VR502 so that the DC voltmeter reads $10 \pm 0.5\text{mV}$.

SEMICONDUCTORS

● IC's

TMP87C846N (IC901)

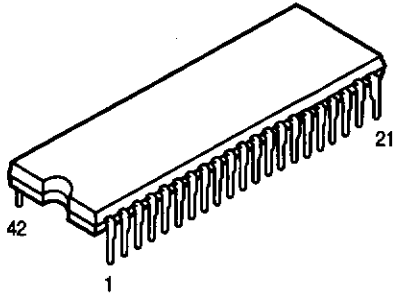

Pin	Function
1	AC power relay drive
2	Analog switch data
3	Analog switch strobe
4	Analog switch clock
5	Mute/standby LED drive
6	Motor volume up
7	Remote control signal input
8	TAPE-2 LED drive
9	TAPE-1 LED drive
10	
11	AUX LED drive
12	TUNER LED drive
13	CD LED drive
14	PHONO LED drive
15	To Vss
16	Reset
17	X'tal input
18	X'tal output
19	GND
20	To VDD
21	
22	
23	REC OUT selector switch input
24	Function switch encoder input
25	
26	Muting signal output
27	
28	
29	Protector input
30	Power off
31	Motor volume down
32	
33	
34	
35	
36	
37	
38	
39	
40	
41	
42	

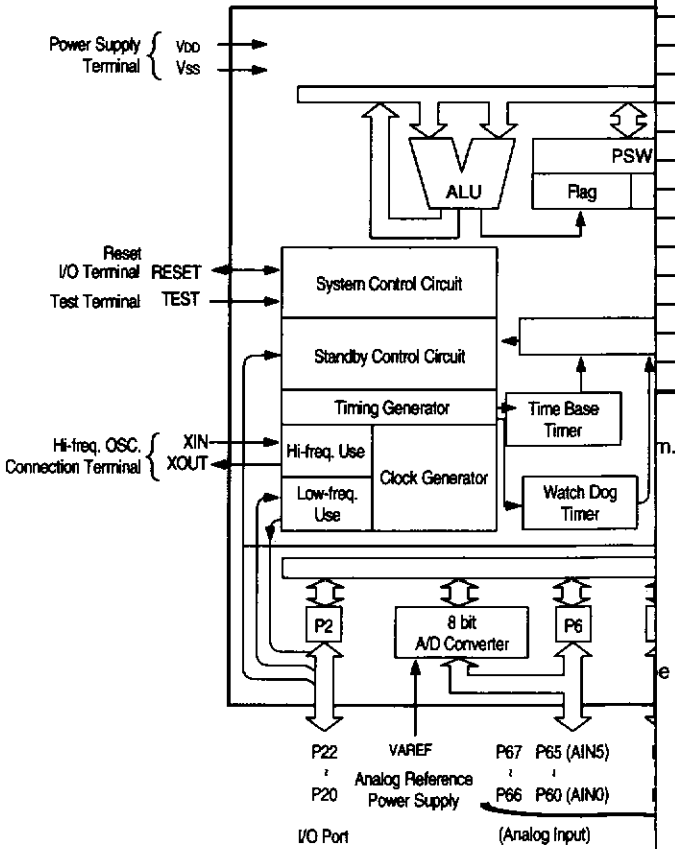

n.
e interfaced.

LB1639 (IC902)

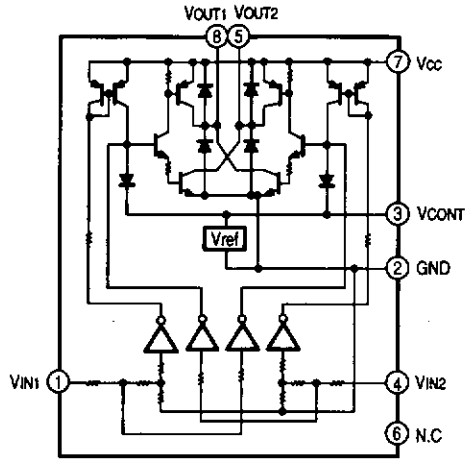
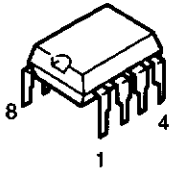

**NJM2068DDC (IC401,501)
NJM2043DD (IC301)**

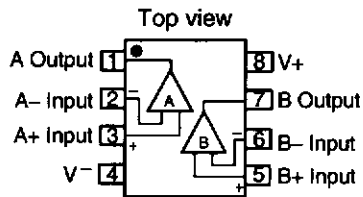
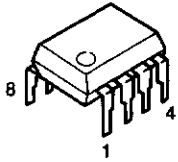

**NJM7806FA(S) (IC903)
NJM7809FA(S) (IC101)**

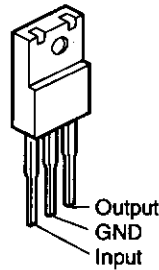

GP1U271X (Remote Control Sensor) (IC904)

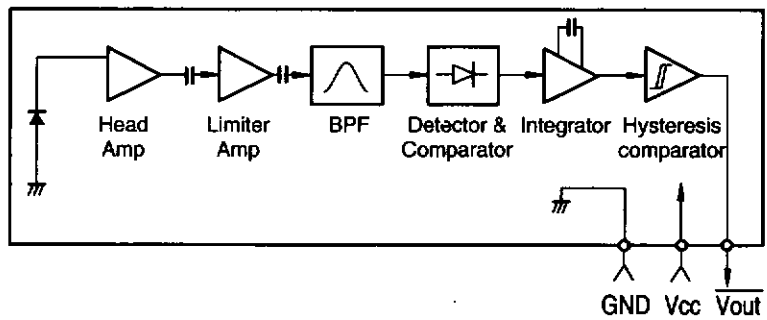
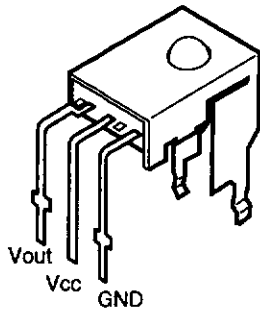

**● IC PROTECTOR
ICP-N15 (IC102,103)**

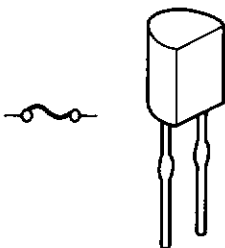

● TRANSISTORS

2SA933S (S)
2SC1740 (S)

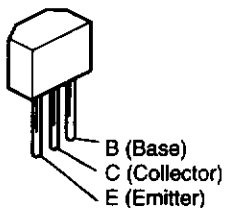

2SA988 (E/F)
2SC1841 (E/F)

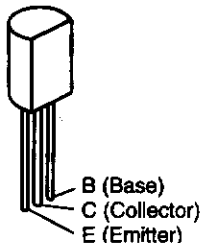

2SB1274 (R/S)
2SD1913 (R/S)

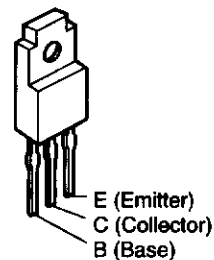

2SK184C (GR)/(BL)

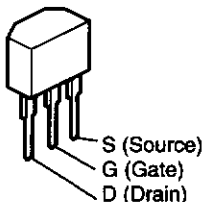

2SB1383 (P/Y)
2SD2083 (P/Y)

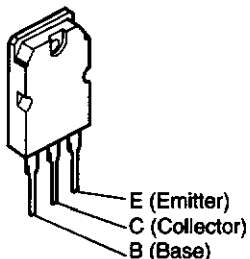

2SC4495 (O/Y)

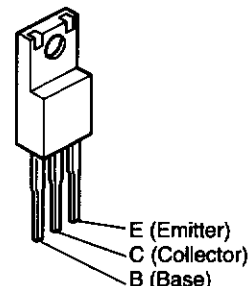

2SC2412K (S)

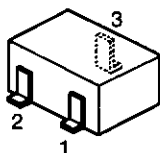

1: E (Emitter)
2: B (Base)
3: C (Collector)

DTA114EK
DTC114EK

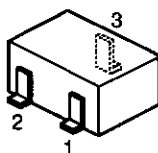

1: E (Emitter)
2: B (Base)
3: C (Collector)

DTA114EK

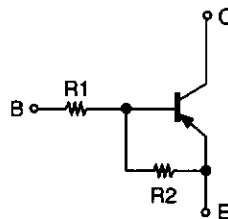

DTC114EK

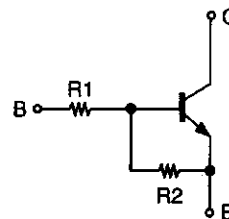

	R1	R2
DTA114EK	10 kohm	10 kohm
DTC114EK	10 kohm	10 kohm

RN1205 (2.2k-47k)

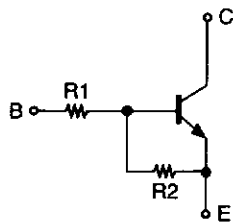
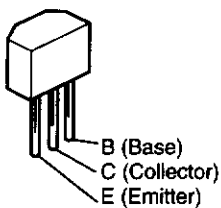

	R1	R2
RN1205	2.2 kohm	47 kohm

● DIODES (including LED)

1SS270A

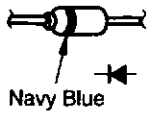

1SR35-400A

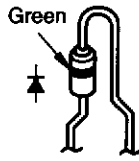

MTZJ2.7A
MTZJ3.3A
MTZJ6.2A
MTZJ7.5C
MTZJ15A
MTZJ18A

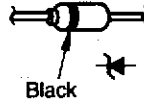

SLR-342VR (LED)
SEL-1210S

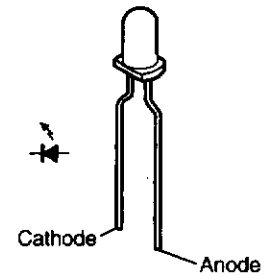

FMG-22S

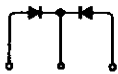
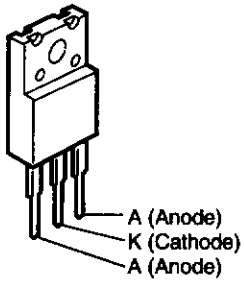

FMG-22R

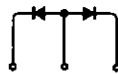
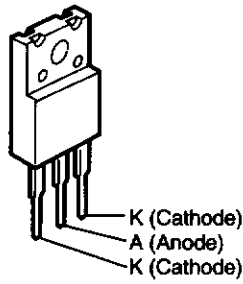

MA152WA

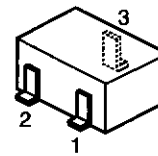

1: (Cathode)
2: (Cathode)
3: (Anode)

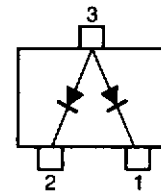

● POSISTOR

PTH9M04BC222TS2F333 (TH701)

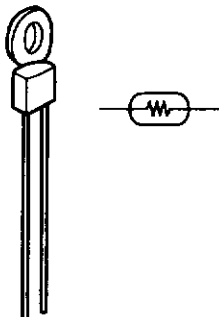

PRINTED WIRING BOARDS

1U-3247 MAIN P.W.B. UNIT ASS'Y

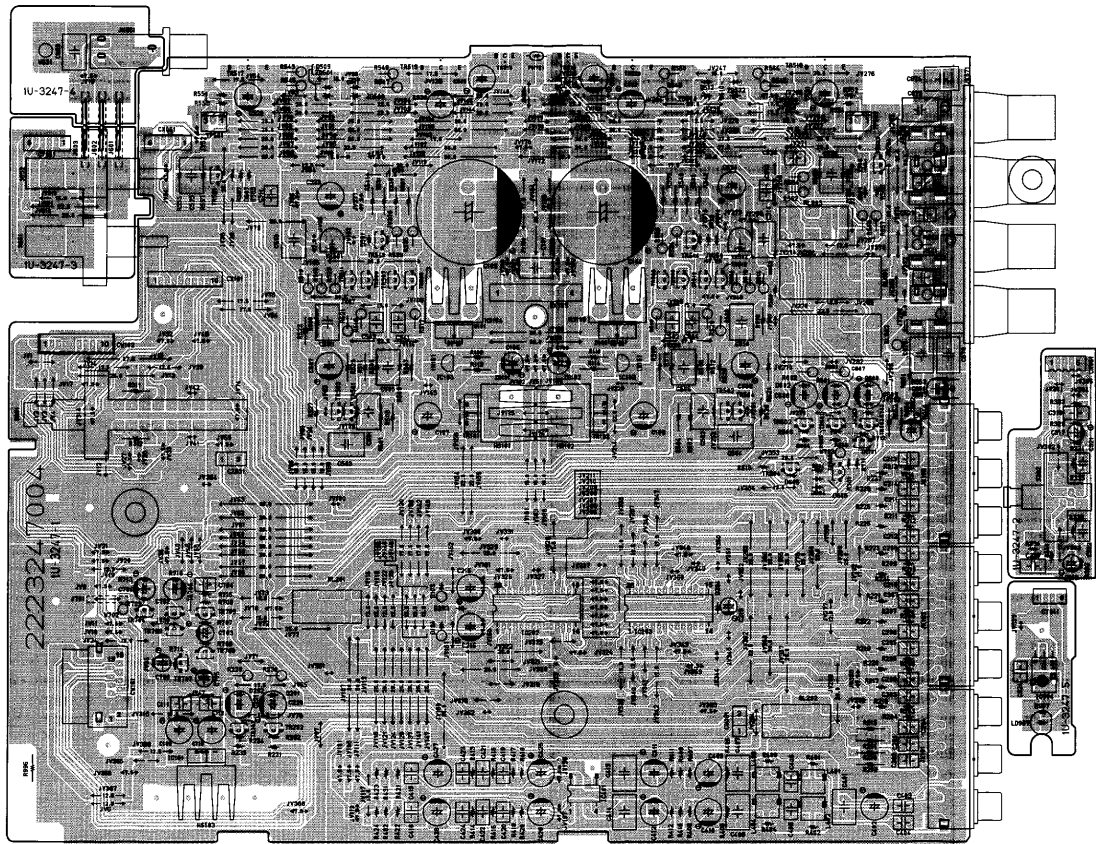

COMPONENT SIDE

1 2 3 4 5 6 7 8

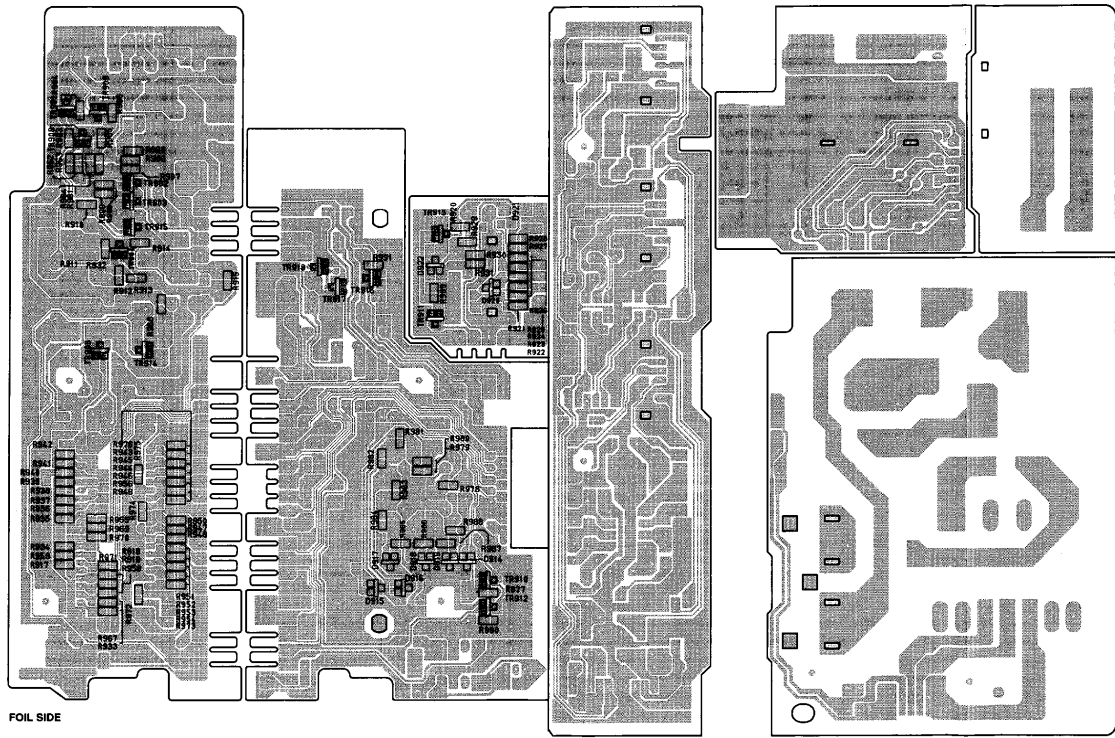

A
B
C
D
E

NOTE FOR PARTS LIST

- Part indicated with the mark "Q" are not always in stock and possibly to take a long period of time for supplying, or in some case supplying of part may be refused.
 - When ordering of part, clearly indicate "1" and "1" (i) to avoid mis-supplying.
 - Ordering part without stating its part number can not be supplied.
 - Part indicated with the mark "M" is not illustrated in the exploded view.
 - Not including Carbon Film ±5%, 1/4W Type in the P.W.Board parts list. (Refer to the Schematic Diagram for those parts.)
- WARNING:**
Parts marked with this symbol  have critical characteristics. Use ONLY replacement parts recommended by the manufacturer.

Resistors

Ex.: **RN 14K 2E 182 G FR**
Type Shape Power Resist- Allowable error Others

RD : Carbon	2E : 1/8W	F : ±1%	P : Pulse-resistant type
RC : Composites	2E : 1/4W	G : ±2%	NL : Low noise type
RS : Metal oxide film	2H : 1/2W	J : ±5%	NB : Non-burning type
RW : Winding	3A : 1W	K : ±10%	FR : Flame-resistant
RN : Metal film	3D : 2W	M : ±20%	F : Lead wire forming
RK : Metal matrix	3F : 3W		

*** Resistance**
 $\frac{1}{\text{---}} \frac{\text{---}}{\text{---}} \frac{\text{---}}{\text{---}}$ ⇒ 1800 ohm = 1.8 kohm
 Indicates number of zeros after effective number.
 2-digit effective number.
 • Units: ohm

$\frac{1}{\text{---}} \frac{\text{---}}{\text{---}} \frac{\text{---}}{\text{---}}$ ⇒ 1.2 ohm
 1-digit effective number.
 2-digit effective number, decimal point indicated by R.
 • Units: ohm

Capacitors

Ex.: **CE 04W 1H 2R2 M BP**
Type Shape Dielectric Capacity Allowable error Others

CE : Aluminum foil electrolytic	1A : 10V	G : ±2%	BP : Non-polar type
CA : Aluminum solid electrolytic	1C : 16V	J : ±5%	HR : Ripple-resistant type
CS : Tantalum electrolytic	1E : 25V	K : ±10%	DL : For charge and discharge frequency
CO : Film	1V : 35V	M : ±20%	HF : For assuring high frequency
CC : Ceramic	1H : 50V	Z : ±80%	U : UL part
CF : Oil	2A : 100V	-20%	C : CSA ass
CM : Mica	2B : 125V	P : ±100%	W : UL-CSA type
CH : Metallized	2C : 150V	-5%	UL : UL-CSA type
CK : Metallized	2D : 200V	-5%	F : Lead wire forming
	2E : 250V	D : ±0.25pF	
	2F : 500V	= : Others	
	2J : 630V		

*** Capacity (electrolytic only)**
 $\frac{2}{\text{---}} \frac{2}{\text{---}} \frac{2}{\text{---}}$ ⇒ 2200µF
 Indicates number of zeros after effective number.
 2-digit effective number.
 • Units: mF

$\frac{2}{\text{---}} \frac{2}{\text{---}} \frac{2}{\text{---}}$ ⇒ 2.2mF
 1-digit effective number.
 2-digit effective number, decimal point indicated by R.
 • Units: mF

*** Capacity (except electrolytic)**
 $\frac{2}{\text{---}} \frac{2}{\text{---}} \frac{2}{\text{---}}$ ⇒ 2200pF=0.0022µF
 (More than 2) ⇒ Indicates number of zeros after effective number.
 2-digit effective number.
 • Units: mF

$\frac{2}{\text{---}} \frac{2}{\text{---}} \frac{1}{\text{---}}$ ⇒ 220pF
 (0 or 1) ⇒ Indicates number of zeros after effective number.
 2-digit effective number.
 • Units: pF

• When the dielectric strength is indicated in AC, "AC" is included after the dielectric strength value.

**PARTS LIST OF P.W.B. UNIT
1U-3247 MAIN P.W.B. UNIT ASS'Y**

Ref. No.	Part No.	Part Name	Remarks	Ref. No.	Part No.	Part Name	Remarks																																								
SEMICONDUCTORS GROUP																																															
IC101	253 0753 000	IC NUM7809FA (S)		R201,202	241 2429 948	Carbon film 330kohm 1/4W	RD1482E334J (PSNB)																																								
IC102,103	268 0073 905	IC ICP-N15		R215,216	241 2420 988	Carbon film 220kohm 1/4W	RD1482E221J (PSNB)																																								
IC202	262 2487 009	IC TC9163AN		R311,312	241 2423 972	Carbon film 3.6kohm 1/4W	RD1482E362J (PSNB)																																								
IC203	262 2488 008	IC TC9164AN		R501,502	241 2420 988	Carbon film 220kohm 1/4W	RD1482E221J (PSNB)																																								
IC401	263 0609 002	IC NLM2068DDC		R503,504	241 2429 983	Carbon film 1Mohm 1/4W	RD1482E101J (PSNB)																																								
IC904	499 0290 007	Remoco sensor GP1U271X		R505,506	241 2421 903	Carbon film 270kohm 1/4W	RD1482E271J (PSNB)																																								
TR101	274 0136 012	Transistor 2SD1913 (VS)		R507-510	241 2424 900	Carbon film 4.7kohm 1/4W	RD1482E472J (PSNB)																																								
TR102	272 0093 010	Transistor 2SB1274 (VS)		R511,512	241 2424 988	Carbon film 8.2kohm 1/4W	RD1482E822J (PSNB)																																								
TR201,202	273 0303 910	Transistor 2SC1740S (S)		R513-516	241 2315 983	Carbon film 330ohm 1/4W (FR)	RD1482E331J (FFRS)																																								
TR501-504	275 0055 015	FET 2SK184C (GRJ)(BL)		R517-520	241 2378 962	Carbon film 330ohm 1/4W (NB)	RD1482E331J (UNBS)																																								
TR505-508	273 0235 923	Transistor 2SC1841 (E/F)		R521,522	244 2064 932	Metal oxide 3.9kohm 1W	RS1483A39J (NBS) (S)																																								
TR509-512	271 0131 924	Transistor 2SA988 (E/F)		R523,524	241 2429 983	Carbon film 1Mohm 1/4W	RD1482E101J (PSNB)																																								
TR513,514	273 0235 923	Transistor 2SC1841 (E/F)		R525,526	241 2425 983	Carbon film 27kohm 1/4W	RD1482E273J (PSNB)																																								
TR521,522	273 0235 923	Transistor 2SC1841 (E/F)		R527,528	241 2420 946	Carbon film 150kohm 1/4W	RD1482E151J (PSNB)																																								
TR601,602	273 0303 910	Transistor 2SC1740S (S)		R529,530	241 2377 921	Carbon film 62ohm 1/4W (NB)	RD1482E620J (UNBS)																																								
TR603,604	269 0067 901	Transistor RN1205 (2.2K-47K)		RS31,532	241 2424 955	Carbon film 7.5kohm 1/4W	RD1482E752J (PSNB)																																								
TR701,702	273 0303 910	Transistor 2SC1740S (S)		RS33-536	241 2371 930	Carbon film 160ohm 1/4W (FR)	RD1482E161J (FFRS)																																								
TR704-706	273 0303 910	Transistor 2SC1740S (S)		RS37,538	241 2425 912	Carbon film 13kohm 1/4W	RD1482E132J (PSNB)																																								
TR707	271 0192 905	Transistor 2SA933S (S)		RS39,540	241 2424 900	Carbon film 4.7kohm 1/4W	RD1482E472J (PSNB)																																								
TR708	273 0303 910	Transistor 2SC1740S (S)		R541,542	241 2424 955	Carbon film 7.5kohm 1/4W	RD1482E752J (PSNB)																																								
TR709	271 0131 924	Transistor 2SA988 (E/F)		R543-550	244 2043 982	Metal oxide 0.22kohm 1W	RS1483A22J (NBS) (S)																																								
D101	276 0681 000	Diode FMG-22S		R555-558	241 2425 967	Carbon film 22kohm 1/4W	RD1482E223J (PSNB)																																								
D102	276 0682 009	Diode FMG-22R		R561-564	244 2043 937	Metal oxide 10ohm 1W	RS1483A10J (NBS) (S)																																								
D103,104	276 0704 903	Diode 1SR35-400A		R651,652	241 2425 909	Carbon film 12kohm 1/4W	RD1482E123J (PSNB)																																								
D201-204	276 0432 903	Diode 1SS270A		R653,654	241 2422 902	Carbon film 680kohm 1/4W	RD1482E681J (PSNB)																																								
D501,502	276 0432 903	Diode 1SS270A		R655,656	241 2427 923	Carbon film 100kohm 1/4W	RD1482E104J (PSNB)																																								
D507-512	276 0432 903	Diode 1SS270A		R657,658	244 2052 931	Metal oxide 390ohm 1W	RS1483A391J (NBS) (S)																																								
D601-606	276 0432 903	Diode 1SS270A		R996	241 2429 963	Carbon film 1Mohm 1/4W	RD1482E105J (PSNB)																																								
ZD101,102	276 0645 907	Zener diode MTZJ18A		R998	241 2429 963	Carbon film 1Mohm 1/4W	RD1482E105J (PSNB)																																								
ZD501-504	276 0643 925	Zener diode MTZJ2.7A		VR501,502	211 6075 024	Semi fixed resistor 4.7kohm	V06P847Z (CERMET)																																								
LD907	393 9539 908	LED SLR-342VRF7FLM		CAPACITORS GROUP																																											
<table border="1"> <tr> <td>C101</td> <td>286 1042 903</td> <td>Metallized 0.1µF/250V</td> <td>CF93A2E104K</td> </tr> <tr> <td>C103,104</td> <td>254 6220 009</td> <td>Electrolytic 8200µF/56V</td> <td>CE68W—822M (DL)</td> </tr> <tr> <td>C105,106</td> <td>254 4313 918</td> <td>Electrolytic 10µF/50V</td> <td>CE04W1H100M (ASF)</td> </tr> <tr> <td>C107,108</td> <td>254 4313 798</td> <td>Electrolytic 220µF/50V</td> <td>CE04W1H221M (ASF)</td> </tr> <tr> <td>C109</td> <td>254 4368 947</td> <td>Electrolytic 220µF/25V</td> <td>CE04W1E221M (ASF)</td> </tr> <tr> <td>C110</td> <td>254 4524 943</td> <td>Electrolytic 1µF/50V</td> <td>CE04W1H1µM (SMGRE3)</td> </tr> <tr> <td>C219</td> <td>254 4313 921</td> <td>Electrolytic 22µF/50V</td> <td>CE04W1H220M (ASF)</td> </tr> <tr> <td>C317,318</td> <td>254 4524 927</td> <td>Electrolytic 0.33µF/50V</td> <td>CE04W1H33µM (SMGRE3)</td> </tr> <tr> <td>C319,320</td> <td>256 1058 955</td> <td>Metallized 0.008µF/50V</td> <td>CF93A1H683J (JL)</td> </tr> <tr> <td>C321,322</td> <td>255 1265 994</td> <td>Mylar film 0.033µF/50V</td> <td>CF033M1H0333J (B)</td> </tr> </table>								C101	286 1042 903	Metallized 0.1µF/250V	CF93A2E104K	C103,104	254 6220 009	Electrolytic 8200µF/56V	CE68W—822M (DL)	C105,106	254 4313 918	Electrolytic 10µF/50V	CE04W1H100M (ASF)	C107,108	254 4313 798	Electrolytic 220µF/50V	CE04W1H221M (ASF)	C109	254 4368 947	Electrolytic 220µF/25V	CE04W1E221M (ASF)	C110	254 4524 943	Electrolytic 1µF/50V	CE04W1H1µM (SMGRE3)	C219	254 4313 921	Electrolytic 22µF/50V	CE04W1H220M (ASF)	C317,318	254 4524 927	Electrolytic 0.33µF/50V	CE04W1H33µM (SMGRE3)	C319,320	256 1058 955	Metallized 0.008µF/50V	CF93A1H683J (JL)	C321,322	255 1265 994	Mylar film 0.033µF/50V	CF033M1H0333J (B)
C101	286 1042 903	Metallized 0.1µF/250V	CF93A2E104K																																												
C103,104	254 6220 009	Electrolytic 8200µF/56V	CE68W—822M (DL)																																												
C105,106	254 4313 918	Electrolytic 10µF/50V	CE04W1H100M (ASF)																																												
C107,108	254 4313 798	Electrolytic 220µF/50V	CE04W1H221M (ASF)																																												
C109	254 4368 947	Electrolytic 220µF/25V	CE04W1E221M (ASF)																																												
C110	254 4524 943	Electrolytic 1µF/50V	CE04W1H1µM (SMGRE3)																																												
C219	254 4313 921	Electrolytic 22µF/50V	CE04W1H220M (ASF)																																												
C317,318	254 4524 927	Electrolytic 0.33µF/50V	CE04W1H33µM (SMGRE3)																																												
C319,320	256 1058 955	Metallized 0.008µF/50V	CF93A1H683J (JL)																																												
C321,322	255 1265 994	Mylar film 0.033µF/50V	CF033M1H0333J (B)																																												
RESISTORS GROUP																																															
R109,110	241 2425 967	Carbon film 23kohm 1/4W	RD1482E233J (PSNB)																																												
R113,114	241 2422 944	Carbon film 1kohm 1/4W	RD1482E102J (PSNB)																																												
C407,408	253 1179 929	Ceramic 150pF/50V	CK45B1H151K																																												
C409,410	254 4538 900	Electrolytic 10µF/16V	CE04W1C10µM (SMGRE3)																																												

Ref. No.	Part No.	Part Name	Remarks	Ref. No.	Part No.	Part Name	Remarks	Q'ty
C411,412	254 4536 931	Electrolytic 220 μ F/10V	CE04W1A221M (SMG/RE3)	OTHER PARTS GROUP				
C419,420	255 1265 907	Mylar film 6800pF/50V	CQ93M1H682J (B)	CW102	205 1081 005	10P FJ connector base		1
C421,422	255 1265 978	Mylar film 0.022 μ F/50V	CQ93M1H223J (B)	CW161	205 1056 027	16P connector socket TKC-V		1
C423,424	255 1264 940	Mylar film 2200pF/50V	CQ93M1H222J (B)	CX051	205 0885 008	5P connector socket (TUC-P)		1
C425,426	254 4313 963	Electrolytic 1 μ F/50V	CE04W1H010M (ASF)	CX061	205 0343 061	6P connector base (KR-PH)		1
C427,428	254 4524 956	Electrolytic 2.2 μ F/35V	CE04W1H2R2M (SMG/RE3)	CX101	205 0375 000	10P connector base (KR-PH)		1
C501-504	255 4235 918	Polypropylene film 100pF/100V	CQ93P2A101J (NH)	CX705	205 0087 042	4P wrapping terminal		1
C505,506	255 1264 908	Mylar film 1000pF/50V	CQ93M1H102J (B)	CY041	205 0343 045	4P connector base (KR-PH)		1
C507,508	254 4492 907	Electrolytic 47 μ F/25V	CE04W1E470M (ASF)	CY061	205 0343 061	6P connector base (KR-PH)		1
C509,510	255 4232 924	Polypropylene film 39pF/100V	CQ93P2A390J (NH)	JK101-103	204 8543 006	6P pin jack		3
C523,524	254 4313 950	Electrolytic 100 μ F/50V	CE04W1H101M (ASF)	JK651	204 8341 004	Headphone jack		1
C525,526	255 1264 908	Mylar film 1000pF/50V	CQ93M1H102J (B)	JK671	205 0472 013	8P SP terminal (EAEK)		1
C527,528	256 1058 971	Metallized 0.1 μ F/50V	CF93A1H104J (JL)	RL201,202	214 0127 003	Relay (RY-12W)		2
C541-544	255 1264 940	Mylar film 2200pF/50V	CQ93M1H222J (B)	RL601,602	214 0195 006	Relay (FTR-F1)		2
C651,652	254 4525 913	Electrolytic 47 μ F/50V	CE04W1H470M (SMG/RE3)	RL603	214 0127 003	Relay (RY-12W)		1
C653	255 1264 908	Mylar film 1000pF/50V	CQ93M1H102J (B)	S301	212 1130 006	1P push switch		1
C701	254 4541 942	Electrolytic 100 μ F/25V	CE04W1E101M (SMG/RE3)	S302	212 1175 003	1P push switch	<i>Lowness</i>	1
C702	254 4533 947	Electrolytic 330 μ F/6.3V	CE04W0J331M (SMG/RE3)	S651	212 4690 006	2P push switch		1
C703	254 4525 900	Electrolytic 33 μ F/50V	CE04W1H330M (SMG/RE3)	TP501,502	205 0190 036	3P NH connector base		2
C704	255 1265 936	Mylar film 0.01 μ F/50V	CQ93M1H103J (B)	W651	203 0501 027	1P SIN connector Ass'y		1
C705	254 4524 914	Electrolytic 0.22 μ F/50V	CE04W1HR22M (SMG/RE3)		417 0476 007	Radiator		3
C706	254 4524 943	Electrolytic 1 μ F/50V	CE04W1H010M (SMG/RE3)		471 3304 028	Screw 3x8 CBS-B		3
C924	255 1265 936	Mylar film 0.01 μ F/50V	CQ93M1H103J (B)					

1U-3248 F. SW. P.W.B. UNIT ASS'Y

Ref. No.	Part No.	Part Name	Remarks
SEMICONDUCTORS GROUP			
IC301	265 0037 007	IC NJM2043DD	
IC901	262 2469 108	IC TMP87C846N	
IC902	263 0476 002	IC LB1639	
IC903	263 0793 002	IC NJM7806FA (S)	
TR901,902	273 0384 900	Transistor 2SC2412K (S)	
TR903	269 0082 902	Transistor DTC114EK	
TR904	273 0384 900	Transistor 2SC2412K (S)	
TR905	269 0082 902	Transistor DTC114EK	
TR908,909	273 0384 900	Transistor 2SC2412K (S)	
TR910-917	269 0083 901	Transistor DTA114EK	
TR918	269 0082 902	Transistor DTC114EK	
D121	276 0432 903	Diode 1SS270A	
D901,902	276 0704 903	Diode 1SR35-400A	
D905-908	276 0704 903	Diode 1SR35-400A	
D909-911	276 0432 903	Diode 1SS270A	
D913	276 0432 903	Diode 1SS270A	
D914-922	276 0711 909	Diode MA152WA	
ZD121,122	276 0637 902	Zener diode MTZJ6.2A	
ZD901	276 0635 904	Zener diode MTZJ7.5C	
ZD902	276 0634 905	Zener diode MTZJ3.3A	
LD901-906	393 9434 906	LED SEL1210S	Red
RESISTORS GROUP			
R901,902	244 2064 974	Metal oxide 33ohm 1W (NB)	RS14B3A330JNBS (S)
R903	247 0009 901	Carbon chip 4.7kohm 1/10W	RM73B-472J
R904	247 0011 944	Carbon chip 47kohm 1/10W	RM73B-473J
R905	241 2387 940	Carbon film 4.7ohm 1/4W (NB)	RD14B2E4R7JNBS
R906,907	247 0011 944	Carbon chip 47kohm 1/10W	RM73B-473J
R908	247 0007 945	Carbon chip 1kohm 1/10W	RM73B-102J
R909	247 0009 901	Carbon chip 4.7kohm 1/10W	RM73B-472J
R910	247 0007 945	Carbon chip 1kohm 1/10W	RM73B-102J
R911	247 0009 985	Carbon chip 10kohm 1/10W	RM73B-103J
R912	247 0009 901	Carbon chip 4.7kohm 1/10W	RM73B-472J
R913	247 0009 985	Carbon chip 10kohm 1/10W	RM73B-103J
R914	247 0013 900	Carbon chip 220kohm 1/10W	RM73B-224J
R915	247 0009 985	Carbon chip 10kohm 1/10W	RM73B-103J
R917	247 0011 944	Carbon chip 47kohm 1/10W	RM73B-473J
R918-920	247 0007 945	Carbon chip 1kohm 1/10W	RM73B-102J
R921	247 0004 993	Carbon chip 91ohm 1/10W	RM73B-910J
R922	247 0005 918	Carbon chip 110ohm 1/10W	RM73B-111J
R923	247 0005 934	Carbon chip 130ohm 1/10W	RM73B-131J
R924	247 0005 950	Carbon chip 160ohm 1/10W	RM73B-161J
R925	247 0005 989	Carbon chip 220ohm 1/10W	RM73B-221J
R926	247 0006 917	Carbon chip 300ohm 1/10W	RM73B-301J

Ref. No.	Part No.	Part Name	Remarks
R927	247 0006 946	Carbon chip 390ohm 1/10W	RM73B-391J
R928	247 0006 991	Carbon chip 620ohm 1/10W	RM73B-621J
R929	247 0007 945	Carbon chip 1kohm 1/10W	RM73B-102J
R930	247 0008 915	Carbon chip 2kohm 1/10W	RM73B-202J
R931	247 0009 930	Carbon chip 6.2kohm 1/10W	RM73B-622J
R932	247 0009 985	Carbon chip 10kohm 1/10W	RM73B-103J
R933	247 0009 901	Carbon chip 4.7kohm 1/10W	RM73B-472J
R934-939	247 0011 944	Carbon chip 47kohm 1/10W	RM73B-473J
R940	247 0007 945	Carbon chip 1kohm 1/10W	RM73B-102J
R941-943	247 0011 944	Carbon chip 47kohm 1/10W	RM73B-473J
R944-946	247 0007 945	Carbon chip 1kohm 1/10W	RM73B-102J
R947,948	247 0011 944	Carbon chip 47kohm 1/10W	RM73B-473J
R949-954	247 0006 988	Carbon chip 560ohm 1/10W	RM73B-561J
R955,956	247 0009 985	Carbon chip 10kohm 1/10W	RM73B-103J
R958,959	247 0011 944	Carbon chip 47kohm 1/10W	RM73B-473J
R961	247 0012 927	Carbon chip 100kohm 1/10W	RM73B-104J
R962	247 0009 985	Carbon chip 10kohm 1/10W	RM73B-103J
R963-966	247 0009 901	Carbon chip 4.7kohm 1/10W	RM73B-472J
R967	247 0011 944	Carbon chip 47kohm 1/10W	RM73B-473J
R968	247 0009 901	Carbon chip 4.7kohm 1/10W	RM73B-472J
R969-971	247 0007 945	Carbon chip 1kohm 1/10W	RM73B-102J
R972	247 0014 967	Carbon chip 1Mohm 1/10W	RM73B-105J
R973-977	247 0007 945	Carbon chip 1kohm 1/10W	RM73B-102J
R978	247 0004 993	Carbon chip 91ohm 1/10W	RM73B-910J
R979	247 0005 918	Carbon chip 110ohm 1/10W	RM73B-111J
R980	247 0005 934	Carbon chip 130ohm 1/10W	RM73B-131J
R981	247 0005 950	Carbon chip 160ohm 1/10W	RM73B-161J
R982	247 0005 989	Carbon chip 220ohm 1/10W	RM73B-221J
R983	247 0006 917	Carbon chip 300ohm 1/10W	RM73B-301J
R984	247 0006 946	Carbon chip 390ohm 1/10W	RM73B-391J
R985	247 0006 991	Carbon chip 620ohm 1/10W	RM73B-621J
R986	247 0007 945	Carbon chip 1kohm 1/10W	RM73B-102J
R987	247 0008 915	Carbon chip 2kohm 1/10W	RM73B-202J
R988	247 0009 930	Carbon chip 6.2kohm 1/10W	RM73B-622J
R989-991	247 0009 901	Carbon chip 4.7kohm 1/10W	RM73B-472J
VR301	211 0902 009	Variable resistor 30kohm	VOLUME
VR302	211 0798 103	Variable resistor 100kohm	BALANCE
VR303	211 0834 009	Variable resistor 30kohm	BASS
VR304	211 0834 012	Variable resistor 10kohm	TREBLE
CAPACITORS GROUP			
C151,152	253 8022 707	Ceramic 0.01µF/250V (AC)	CK45F2EAC103M
C153	254 4313 921	Electrolytic 22µF/50V	CE04W1H220M (ASF)
C301,302	254 4524 972	Electrolytic 4.7µF/50V	CE04W1HR47M (SMG/RE3)
C305,306	254 4538 900	Electrolytic 10µF/16V	CE04W1C100M (SMG/RE3)
C307,308	254 4313 963	Electrolytic 1µF/50V	CE04W1H010M (ASF)
C309,310	254 4524 901	Electrolytic 0.1µF/50V	CE04W1HR10M (SMG/RE3)
C311,312	254 4524 930	Electrolytic 0.47µF/50V	CE04W1HR47M (SMG/RE3)
C313,314	255 1265 994	Mylar film 0.033µF/50V	CQ93M1H333J (B)
C315,316	254 4524 914	Electrolytic 0.22µF/50V	CE04W1HR22M (SMG/RE3)

Ref. No.	Part No.	Part Name	Remarks	Ref. No.	Part No.	Part Name	Remarks	Q'ty	
C323,324	253 4538 949	Ceramic 100pF/50V	CC45SL1H101J	OTHER PARTS GROUP					
C325	255 1265 936	Mylar film 0.01μF/50V	CQ93M1H103J (B)	CW051	205 0884 009	5P connector base (TUC-P)		1	
C327	255 4235 976	Polypropylene film 0.015μF/100V	CQ93P2A153J (NH)	CX031	205 0355 033	3P KR connector base (L)		1	
C329,330	255 1264 966	Mylar film 3300pF/50V	CQ93M1H332J (B)	CX041	205 0343 045	4P connector base (KR-PH)		1	
C901	256 1058 971	Metallized 0.1μF/50V	CF93A1H104J (JL)	CX053	205 0343 058	5P connector base (KR-PH)		1	
C902	254 4313 921	Electrolytic 22μF/50V	CE04W1H220M (ASF)	CX102	205 1000 002	10P FJ connector plug		1	
C903	254 4522 796	Electrolytic 1000μF/35V	CE04W1V102M (SMG/RE3)	CX161	205 1055 028	16P connector base (TKC-V)		1	
C904	254 4524 943	Electrolytic 1μF/50V	CE04W1H010M (SMG/RE3)	CX701~703	205 0606 025	2P wrapping terminal		3	
C907	254 4406 702	Electrolytic 3300μF/16V	CE04W1C332M (SMG)	CY031	205 0355 033	3P KR connector base (L)		1	
C908	254 4524 914	Electrolytic 0.22μF/50V	CE04W1HR22M (SMG/RE3)	CY053	205 0343 058	5P connector base (KR-PH)		1	
C911	255 1265 936	Mylar film 0.01μF/50V	CQ93M1H103J (B)	CY101	205 0375 000	10P connector base (KR-PH)		1	
C912	254 4524 956	Electrolytic 2.2μF/35V	CE04W1H2R2M (SMG/RE3)	CY703	205 0442 001	2P wrapping terminal		1	
C913	256 1058 971	Metallized 0.1μF/50V	CF93A1H104J (JL)	Δ F101	206 1075 027	Fuse 1.5A		1	
C914	254 4524 914	Electrolytic 0.22μF/50V	CE04W1HR22M (SMG/RE3)	Δ F108	206 1075 043	Fuse 2.5A		1	
C915	255 1265 936	Mylar film 0.01μF/50V	CQ93M1H103J (B)	FF101	202 0040 909	Fuse clip		1	
C917	255 1265 936	Mylar film 0.01μF/50V	CQ93M1H103J (B)	FF108	202 0040 909	Fuse clip		1	
C918	254 4538 900	Electrolytic 10μF/16V	CE04W1C100M (SMG/RE3)	FH101	202 0040 909	Fuse clip		1	
C920	254 4538 900	Electrolytic 10μF/16V	CE04W1C100M (SMG/RE3)	FH108	202 0040 909	Fuse clip		1	
C923	254 4305 968	Electrolytic 1μF/50V	CE04W1H010M (SRE)	RL101	214 0202 009	Relay (TV-8)		1	
C928	256 1058 971	Metallized 0.1μF/50V	CF93A1H104J (JL)	Δ S101	212 1176 002	Power switch (TV-8)		1	
C929	255 1265 936	Mylar film 0.01μF/50V	CQ93M1H103J (B)	S901	212 0405 004	Rotary switch (6-1)		1	
				S902	212 0407 002	Rotary switch (SRRM-12) * <i>Input Selector</i>		1	
				Δ T101	239 4322 007	Power trans. 100 E2		1	
				W301	203 0501 027	1P SIN connector Ass'y		1	
				XL901	399 0107 900	Ceramic resonator CST4.19MGW		1	
					415 0299 000	Condenser cover	for C151,152	2	
					513 2784 040	Fuse label	for F101	1	
					513 2784 053	Fuse label	for F108	1	
					412 4625 008	Earth plate	for VR301	1	

PARTS LIST OF EXPLODED VIEW

Ref. No.	Part No.	Part Name	Remarks	Q'ty	Ref. No.	Part No.	Part Name	Remarks	Q'ty
1	1U-3247	Main P.W.B. unit Ass'y		1	35	112 0744 106	VR. knob Ass'y	Black model	1
1-1		Main unit			35	112 0744 122	VR. knob Ass'y	Gold model	1
1-2		Loud. unit			36	112 0699 109	MARU knob Ass'y	Black model	1
1-3		SP. SW. unit			36	112 0699 125	MARU knob Ass'y	Gold model	1
1-4		H/P unit			37	112 0762 007	Knob (MARU)	Black model	4
1-5		LED UNIT			37	112 0762 023	Knob (MARU)	Gold model	1
2	1U-3248	F. SW. P.W.B. unit Ass'y		1	38	461 0501 005	Rubber sheet	for Inner panel	3
2-1		F. SW. unit			★ 39	445 8004 007	Wire clamp		9
2-2		REC. SEL. SW. unit			40	102 0627 022	Top cover	Black model	1
2-3		U-COM. unit			40	102 0627 035	Top cover	Gold model	1
2-4		Tone unit			41	209 0325 007	Short pin		2
2-5		VOL. unit			42	453 3875 003	AC cord (P)	Black	1
2-6		AC unit			43	414 0853 003	Shield plate		1
2-7		P. SW. unit			44	204 1075 002	Push 1.5A	Black	1
					45	204 1075 006	Push 2.5A	Black	1
3	411 1267 725	Main chassis		1	★ 47	477 0096 007	Push rivet		8
4	104 0194 205	Foot Ass'y		4	★ 48	513 1642 002	No. sheet		1
5	412 2762 002	P.W.B. holder	for AC unit	1	SCREWS & NUTS				
6	105 1337 006	Back panel		1	101	473 7002 018	Screw 3x8 CBTS (S)-Z		6
7	205 0071 016	Terminal Ass'y		1	102	473 7005 002	Screw 3x10 CBTS (S)-Z		14
8	477 0018 001	Washer (P-87)		1	103	473 7015 018	Screw 3x8 CBTS (S)-B		9
9	445 0056 008	Cord bush		1	104	473 7026 007	Screw 4x6 CBTS (S)-B		4
△ 10	205 2073 002	AC cord with plug		1	105	473 7501 030	Screw 3x20 CBTS (P)-Z		1
11	415 0364 032	UL tube (8.3)	for AC cord, L=90	1	106	473 7508 017	Screw 3x10 CBTS (P)-B		13
12	417 0566 302	Power radiator		1	107	473 8007 038	Cup screw 3x14		4
13	412 3225 205	P.W.B. bracket (A)		1	108	477 0064 107	Fixing screw		12
14	279 0034 054	Posistor		1	109	477 0263 005	3P. swelling screw	Black model	4
		PTH9M04BC222TS2F333	TH701	1	109	477 0263 018	3P. swelling screw	Gold model	4
★ 15	415 0309 055	P.V.C. tube (L=07)	for posistor	2	144 269 3058 144 269 3076				
16	415 0234 007	Insulating sheet		4					
17	272 0152 003	Transistor 2SB1383(P/Y)	TR519,520	2					
18	274 0190 003	Transistor 2SD2083(P/Y)	TR517,518	2					
19	273 0450 009	Transistor 2SC4495(O/Y)	TR515,516	2					
20	449 0050 022	Card spacer		1					
21	412 4577 004	Radiator bracket		1					
22	146 2160 008	Inner panel	Black model	1					
22	146 2160 011	Inner panel	Gold model	1					
23	412 2404 027	P.W.B. holder (WLS-10)		2					
24	113 1356 004	Push knob (MARU)	Black model	4					
24	113 1356 062	Push knob (MARU)	Gold model	4					
25	144 2693 003	Front panel Ass'y	Black model	1					
25	144 2693 016	Front panel Ass'y	Gold model	1					
★ 26	204 2552 019	10P KR-KR ribbon 80	for CX,CY101	1					
★ 27	204 0378 088	6P KR-KR ribbon 225	for CZ,CW061	1					
★ 28	203 6386 055	4P KR-KR ribbon 400	for CX,CY041	1					
★ 29	203 8342 097	5P KR-KR ribbon 500	for CX,CY053	1					
★ 29-1	203 4872 011	3P KR-KR ribbon 300	for CX,CY031	1					
★ 30	415 0295 004	Insulating tube	12.7 tube, L=250	1					
△ 31	203 6321 008	Power trans.		1					
★ 32	001 0148 075	Vinyl wire	Orange, L=370	1					
★ 33	001 0148 088	Vinyl wire	Red, L=370	1					
34	113 9213 000	P. knob (P) Ass'y	Black model	1					
34	113 9213 039	P. knob (P) Ass'y	Gold model	1					

EXPLODED VIEW

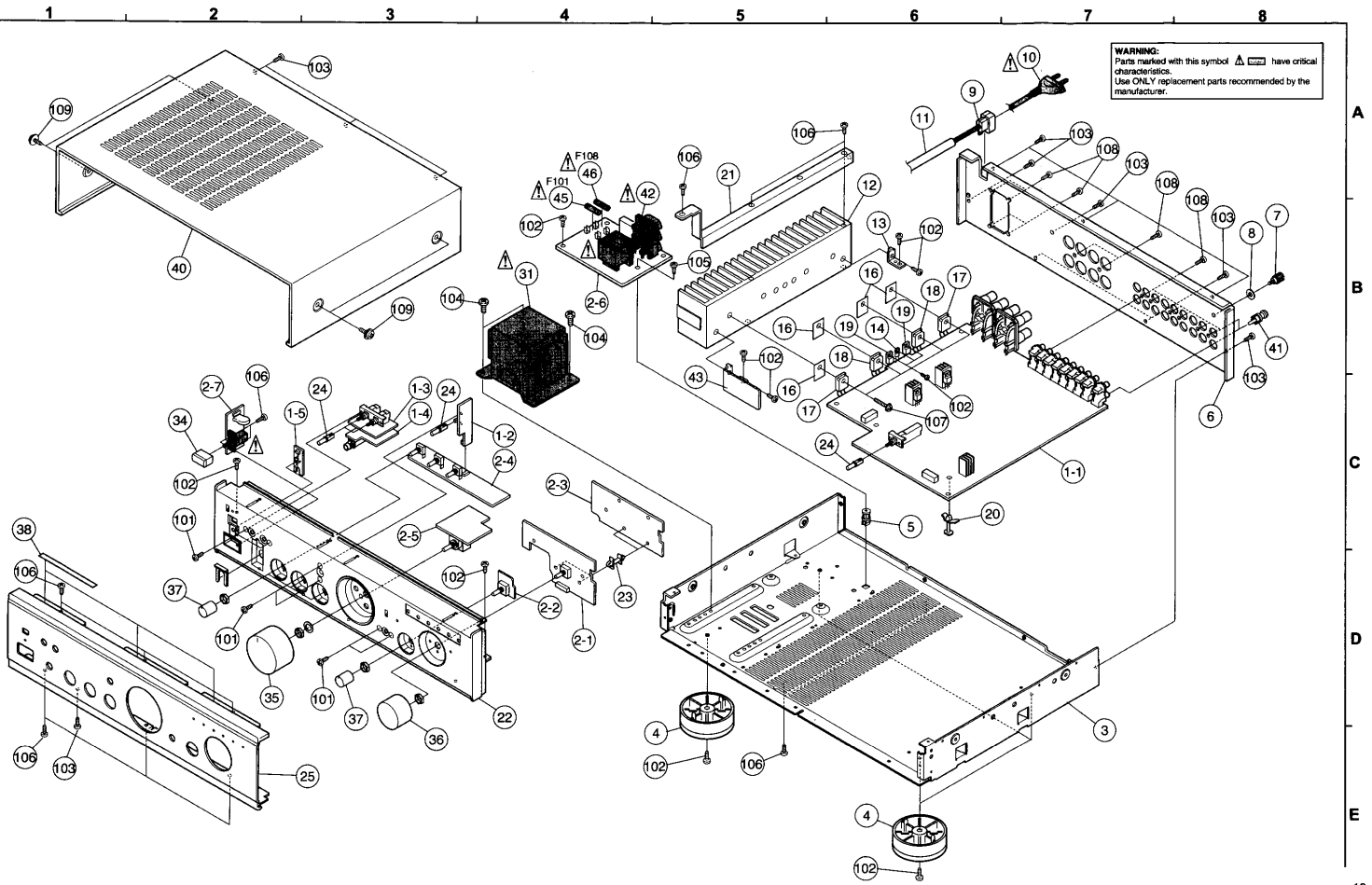

WIRING DIAGRAM

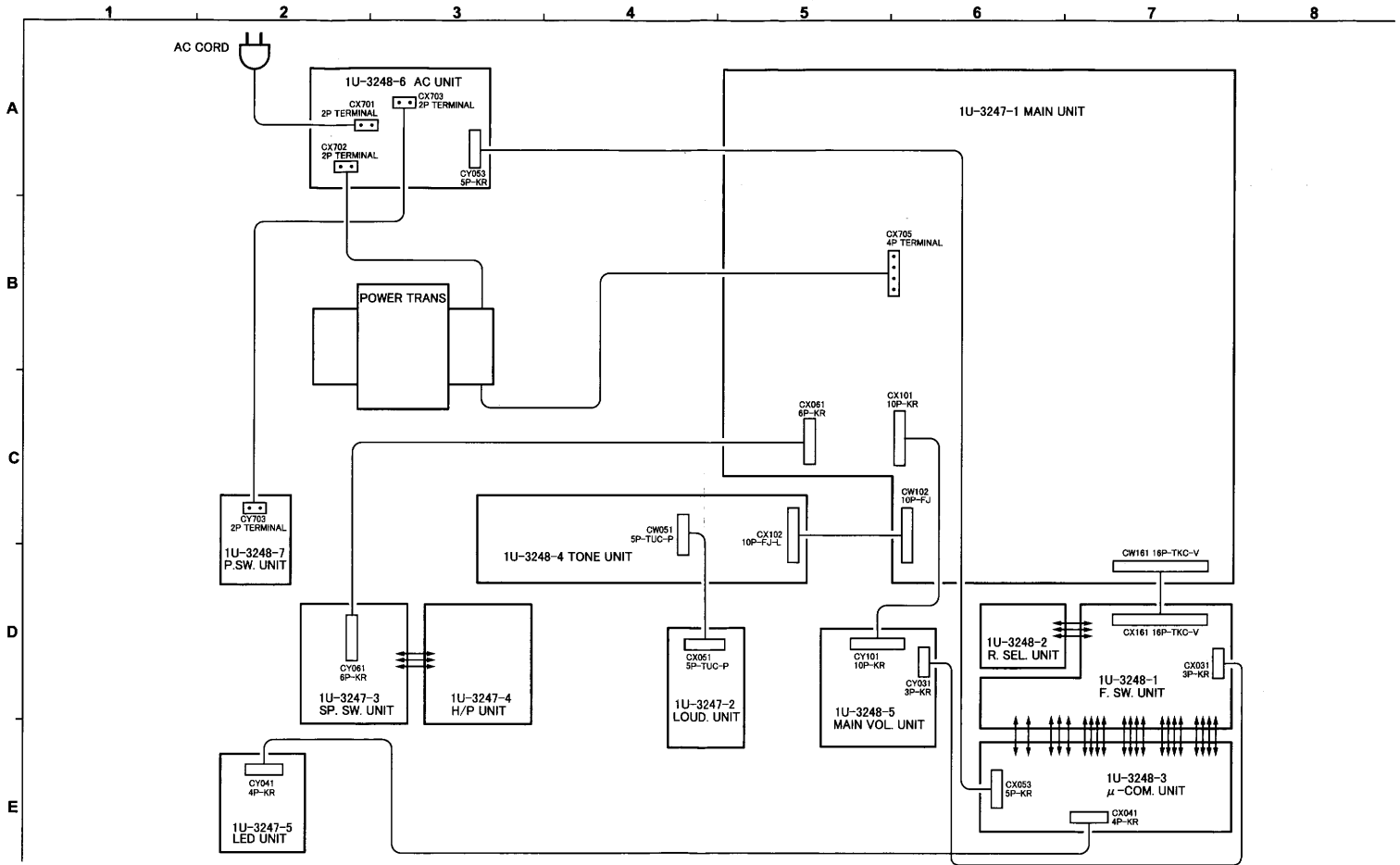

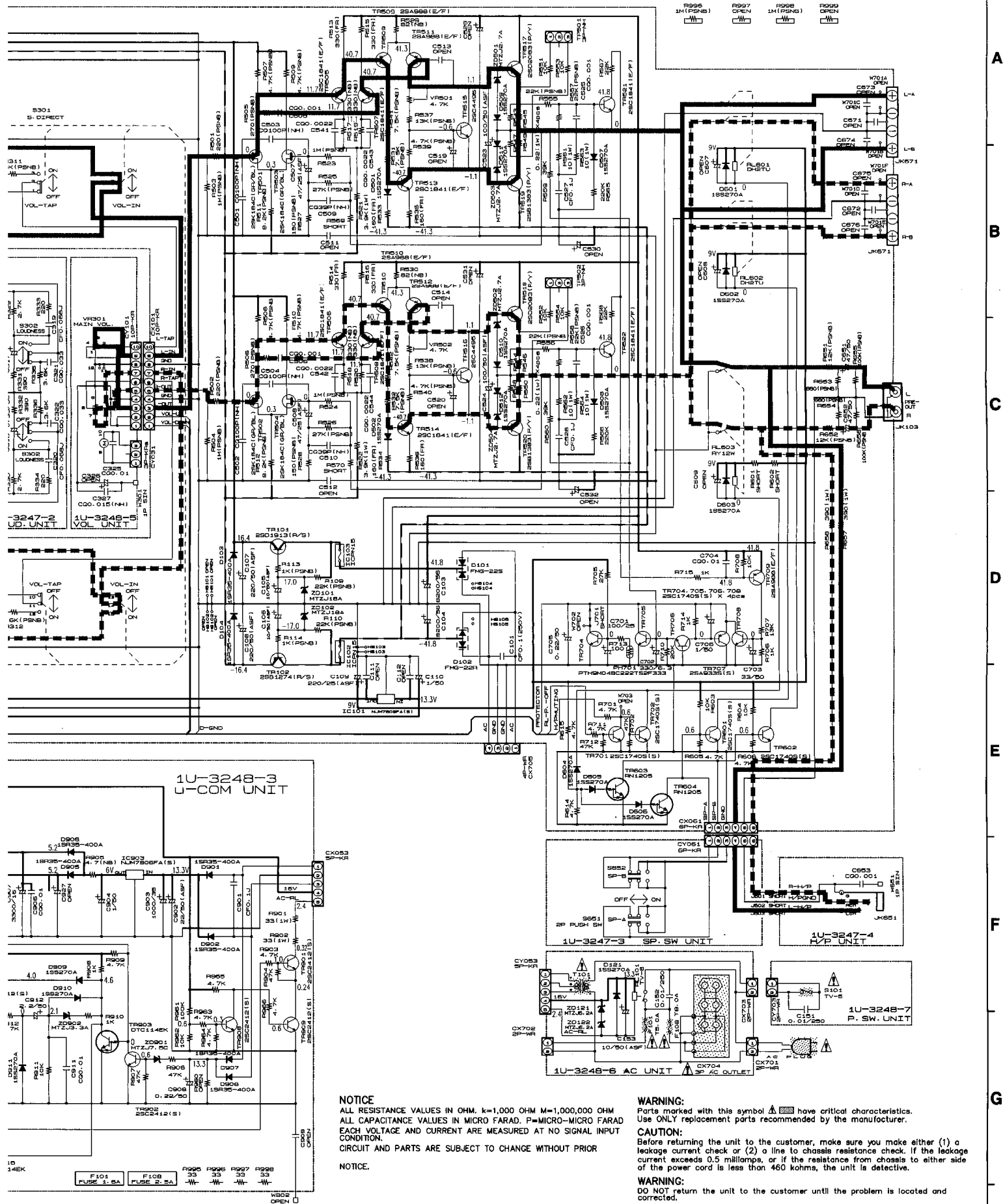

NOTICE
 ALL RESISTANCE VALUES IN OHM. k=1,000 OHM M=1,000,000 OHM
 ALL CAPACITANCE VALUES IN MICRO FARAD. P=MICRO-MICRO FARAD
 EACH VOLTAGE AND CURRENT ARE MEASURED AT NO SIGNAL INPUT
 CONDITION.
 CIRCUIT AND PARTS ARE SUBJECT TO CHANGE WITHOUT PRIOR
 NOTICE.

WARNING:
 Parts marked with this symbol Δ have critical characteristics.
 Use ONLY replacement parts recommended by the manufacturer.
CAUTION:
 Before returning the unit to the customer, make sure you make either (1) a
 leakage current check or (2) a line to chassis resistance check. If the leakage
 current exceeds 0.5 milliamperes, or if the resistance from chassis to either side
 of the power cord is less than 460 kohms, the unit is defective.
WARNING:
 DO NOT return the unit to the customer until the problem is located and
 corrected.

SCHEMATIC DIAGRAM
 1U-3247 MAIN UNIT
 1U-3248 F. SW. UNIT

A
B
C
D
E
F
G
H

SCHEMATIC DIAGRAM

1

2

3

4

5

6

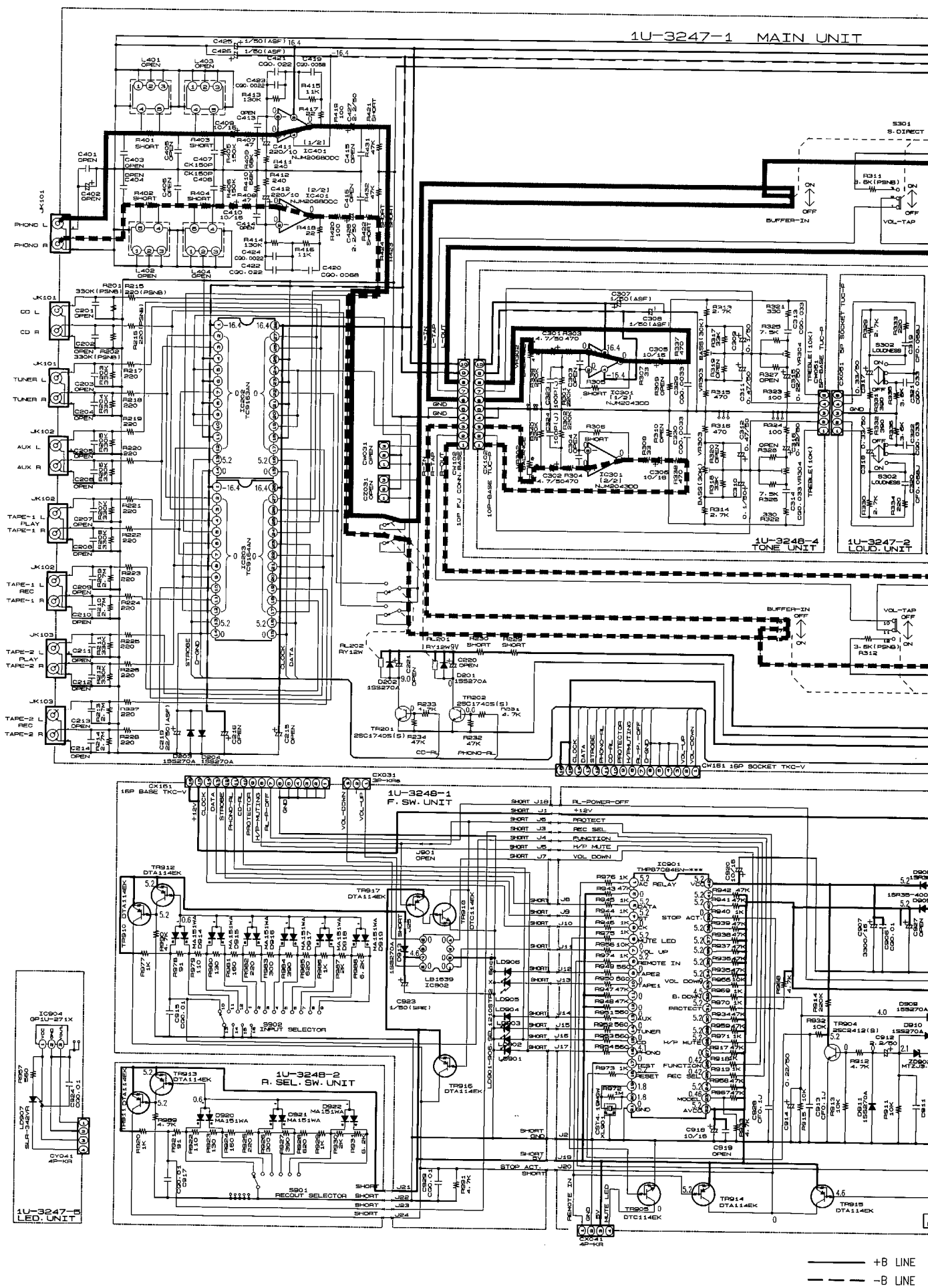

— +B LINE
 --- -B LINE

PACKING VIEW

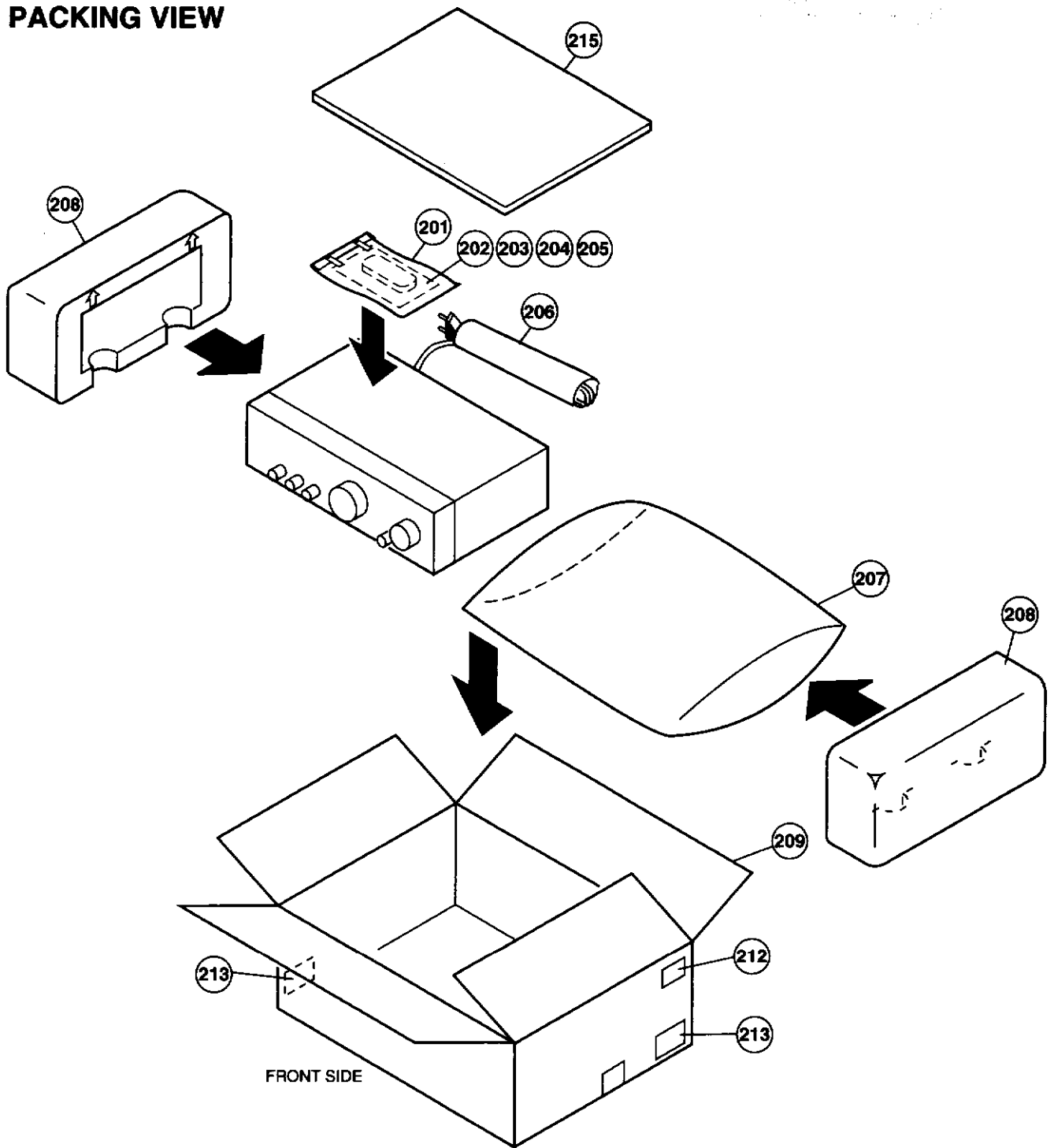

PARTS LIST OF PACKING & ACCESSORIES

Ref. No.	Part No.	Part Name	Remarks	Q'ty	Ref. No.	Part No.	Part Name	Remarks	Q'ty
201	505 9125 009	Poly. cover		1	208	503 1296 008	Cushion		2
202	511 3547 002	Instruction manual		1	209	501 2059 002	Carton case		1
203	515 0867 004	S.S. list (EX)		1	212	517 1417 006	E2 POS label	Black model	1
204	399 0497 005	Remote controller RC-843		1	212	517 1417 019	E2 POS label	Gold model	1
205	—	Battery (R6P)		1	213	—	Control card		1
206	505 0125 005	Stylen paper		1	★ 214	513 9111 001	Color label (Gold)	Gold model only	2
207	505 0131 050	Cabinet cover		1	215	509 0151 003	Top carton		1

DENON

NIPPON COLUMBIA CO. LTD.

14-14, AKASAKA 4-CHOME, MINATO-KU, TOKYO 107-8011 JAPAN

Telephone: 03 (3584) 8111

Cable: NIPPON COLUMBIA TOKYO Telex: JAPANOLA J22591

Printed in Japan X0065 1085 **BU** 0003