

# DENON

FOR  
EUROPEAN, U.K., U.S.A., ASIA MODELS

Hi-Fi Pre-Main Amplifier

## SERVICE MANUAL MODEL PMA-737 SOLID-STATE PRE MAIN AMPLIFIER

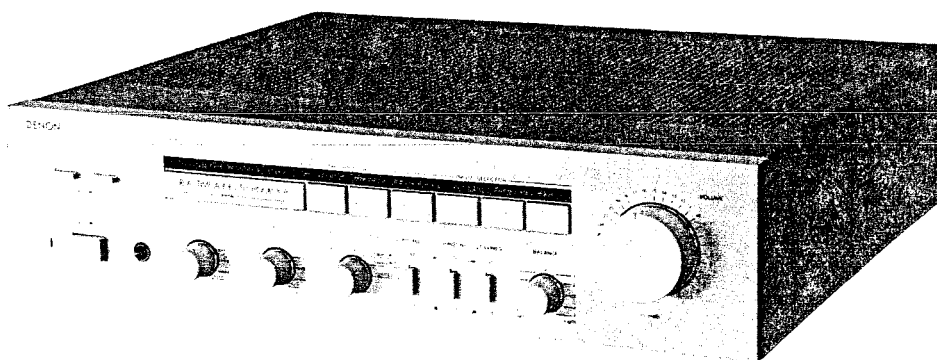

### CONTENTS

SPECIFICATIONS .....	2
CONTROLS AND THEIR DESCRIPTION .....	3
CONNECTIONS .....	4
BLOCK, LEVEL DIAGRAM .....	5
METHOD OF ADJUSTMENTS .....	6, 7
SEMICONDUCTORS .....	8
CONNECTION DIAGRAM .....	9
ETC0712B TONE & POWER UNIT .....	10, 11
ETC0741 C-UNIT .....	11
CTC0711 INPUT & EQ UNIT .....	12~13
ADDENDUM LIST .....	14
WIRING DIAGRAM .....	15
EXPLODED VIEW OF CHASSIS AND CABINET .....	16

**NIPPON COLUMBIA CO., LTD.**

FEB. 1984

## SPECIFICATIONS

## POWER AMPLIFIER SECTION

## Rated Output Power:

Both channel drive (TUNER → SP OUT)  
 55 W + 55 W (8 ohm Load) 20 Hz to 20 kHz  
 65 W + 65 W (4 ohm Load) 20 Hz to 20 kHz  
 1 kHz (4 ohm Load) 60 W + 60 W (IEC  
 Subject to change by temperature test)

Except USA & Canada models

Both channel drive (TUNER → SP OUT)  
 60 Watts minimum rms per channel into 8-ohm with less than  
 0.05% total harmonic distortion from 20 Hz to 20 kHz.  
 65 W + 65 W (4-ohm Load) 20 Hz to 20 kHz at THD 0.05%

USA & Canada models

## Total Harmonic Distortion:

0.05% at rated power (20 Hz ~ 20 kHz, 8-ohm Load)  
 0.007% at -3 dB power (20 Hz ~ 20 kHz, 8-ohm Load)

## Intermodulation Distortion:

7 kHz/60 Hz: 1/4 Below 0.005%  
 (at amplitude output equivalent to rated output)

## Output Band Width:

5 Hz ~ 80 kHz (IHF THD 0.1%)

## Transmission Characteristic:

4 Hz ~ 150 kHz  $\begin{matrix} +0 \\ -3 \end{matrix}$  dB (at 1 W output)

## Input Sensitivity:

150 mV

## Input Impedance:

30 kohm

## Output Impedance:

0.1 ohm (1 kHz)

## Output Terminals:

Speaker: A or B Load 4 ~ 16 ohm  
 A + B Load 8 ~ 16 ohm

Headphone/Stereo Headphone

## EQUALIZER AMPLIFIER SECTION

Equalizer Amplifier Output  
(REC OUT Terminal):

Maximum Output: 10 V (at 47 kohm load)

Rated Output: 150 mV

Total Harmonic Wave Distortion: Below 0.002%  
 (at 1 kHz, 8 V output)

## Input Sensitivity/Input Impedance:

PHONO MM 2.5 mV 47 kohm

MC 200  $\mu$ V 100 ohm

TUNER 150 mV 30 kohm

DAD., VIDEO/AUX, TAPE 150 mV 30 kohm

PHONO (MC) Within  $\pm$  0.3 dB (20 Hz ~ 100 kHz)

## RIAA Deviation:

## OVERALL CHARACTERISTICS

## SN Ratio (IHF A Network):

PHONO MM 86 dB  
 (input terminals short-circuited for 2.5 mV input)  
 MC 70 dB  
 (input terminals short-circuited for 250  $\mu$ V input)

TUNER, TAPE, DAD, VIDEO/AUX 106 dB  
 (input terminals short-circuited)

## Tone Control Adjustable Range:

BASS 100 Hz  $\pm$  8 dB

TREBLE 10 kHz  $\pm$  8 dB

## Loudness Characteristics:

Low frequency 100 Hz + 7 dB

High frequency 10 kHz + 6 dB

## AC OUTLETS:

(For U.S.A. Canada and Asia)

## POWER SOURCE:

U.S.A. and Canada AC 120 V, 60 Hz,  
 Germany and France AC 220 V, 50 Hz,  
 U.K. and Australia AC 240 V, 50 Hz

Asia AC 110/120/220/240 V, 50/60 Hz (Multiple)

## POWER CONSUMPTION:

160 W (U.S.A.) 150 W (IEC) 310 VA (CSA)

140 W (Multiple) 400 W (Maximum output)

## DIMENSIONS:

434 mm(W) x 112 mm(H) x 393 mm(D)

(including rubber feed, control knobs, and terminals)

## WEIGHT:

8.7 kg

\* Design and specifications are subject to change, for improvement, without prior notice.

NOTE: The following codes correspond to the appropriate models.

E1 for Asia, E2 for Europe, E3 for U.S.A., EC for Canada and EK for U.K.

This Service Manual is prepared based on E2.

## CONTROLS AND THEIR DESCRIPTION

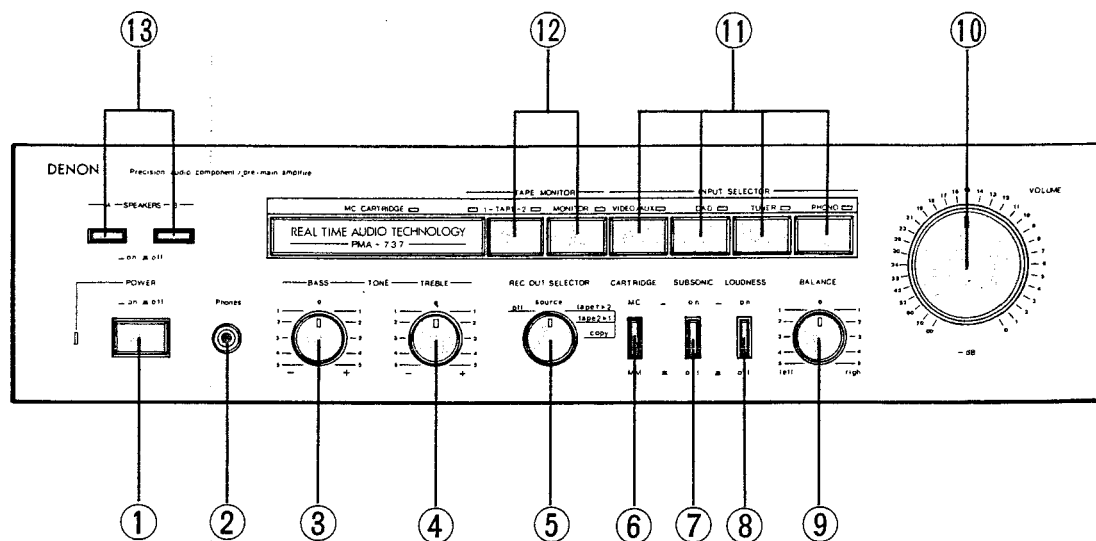

Fig. 1

- |   |  |
|---|--|
| ① POWER & LED Indicator (Power Switch & LED Indicator)  | ⑧ LOUDNESS (Loudness Switch)   |
| ② PHONES (Head Phone Jack)  | ⑨ BALANCE (Balance Control Knob)   |
| ③ BASS (BASS Control Knob)  | ⑩ VOLUME (Main Volume Control Knob)  |
| ④ TREBLE (TREBLE Control Knob)  | ⑪ INPUT SELECTOR (Input Changeover Switch)<br>● Phono, ● tuner, ● DAD, ● VIDEO/AUX |
| ⑤ REC OUT SELECTOR (Recording out Changeover Switch)<br>● off, ● source, ● tape-1 ▶ 2, ● tape-2 ▶ 1 | ⑫ TAPE MONITOR (Tape Monitor Switch)<br>● 1-TAPE-2, ● MONITOR                      |
| ⑥ CARTRIDGE (Cartridge Changeover Switch)<br>■ MC, ■ MM   | ⑬ SPEAKERS (Speaker Changeover Switch)<br>● system-A, ● system-B                   |
| ⑦ SUBSONIC (Subsonic Filter Switch)   |  |

## CONNECTIONS

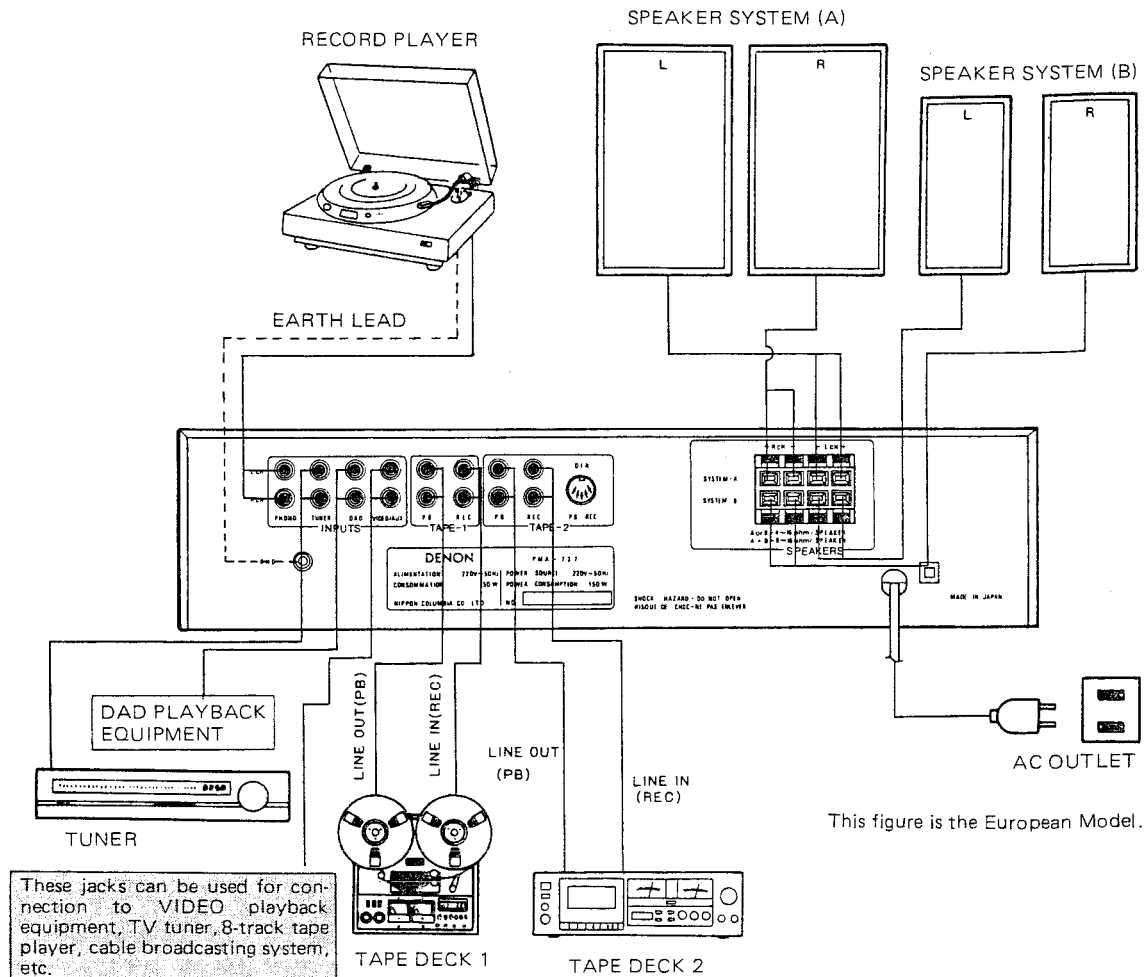

Fig. 2

### • Make Connections with Caution

- Do not connect Power cord to AC outlet until all connections completed.
- Distinguish Left and Right. Be sure connect L to L, and R to R.
- Insert the Plugs snugly. Improper connections may invite noise.
- AC outlets of the unit accept Audio equipment only: do not connect hair dryer etc. to the outlets.
- Do not tie Pin plug with Power cord or lay it along power transformer: it may invite hum and noise.
- "PHONO" input terminal is very highly sensitive. Be sure connect Pin cord to it or may induce hum from the Speakers.

### For USA, CANADA and ASIA model only

#### AC OUTLETS

AC OUTLETS of the Unit accept Tuner, Record Player, Tape Deck etc. which are used with the unit. SWITCHED (100W max):

Power is turned on-off by the Power Switch.

UNSWITCHED (250W max):

Always alive independent of Power Switch.

FOR LINE VOLTAGE PROVIDED MODEL, PLEASE REFER FOLLOWING INSTRUCTION.

- LINE VOLTAGE (Voltage changeover switch) ..... (For ASIA model only)

- \* It is possible to change the voltage by the customer to turn the VOLTAGE SELECTOR KNOB on the back panel for appropriate voltage using by a screw driver.
- \* Do not twist the VOLTAGE SELECTOR KNOB by abnormal force that may damage it.
- \* If the voltage change is not smoothly made, please ask for the qualified service personnel.

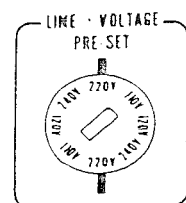

Back Panel

Fig. 3

BLOCK, LEVEL DIAGRAM

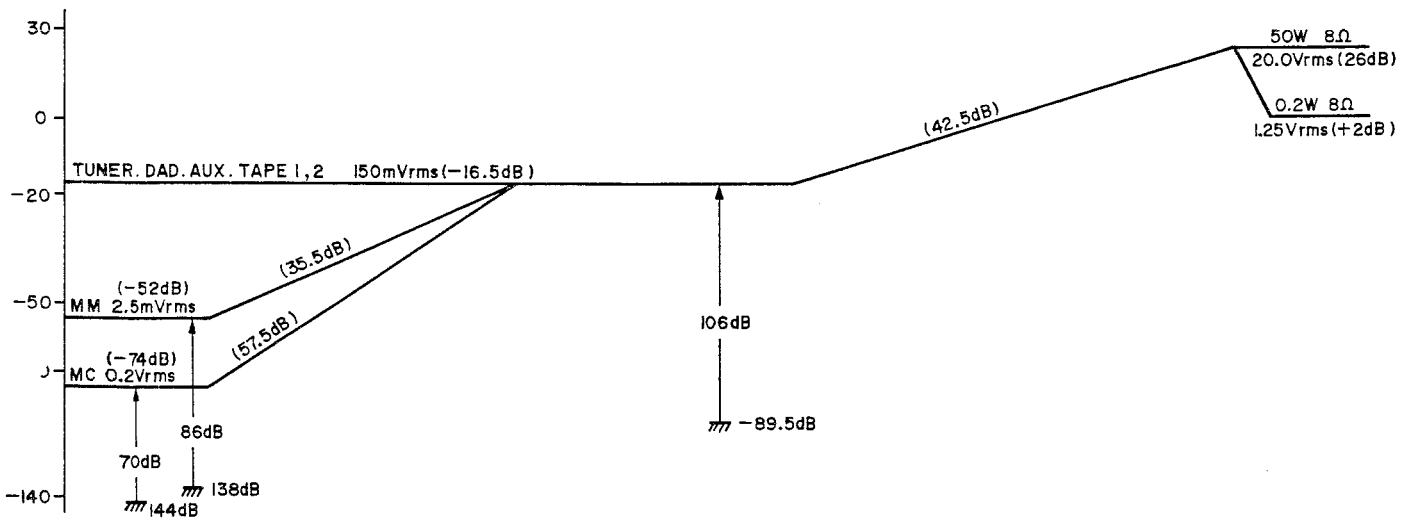
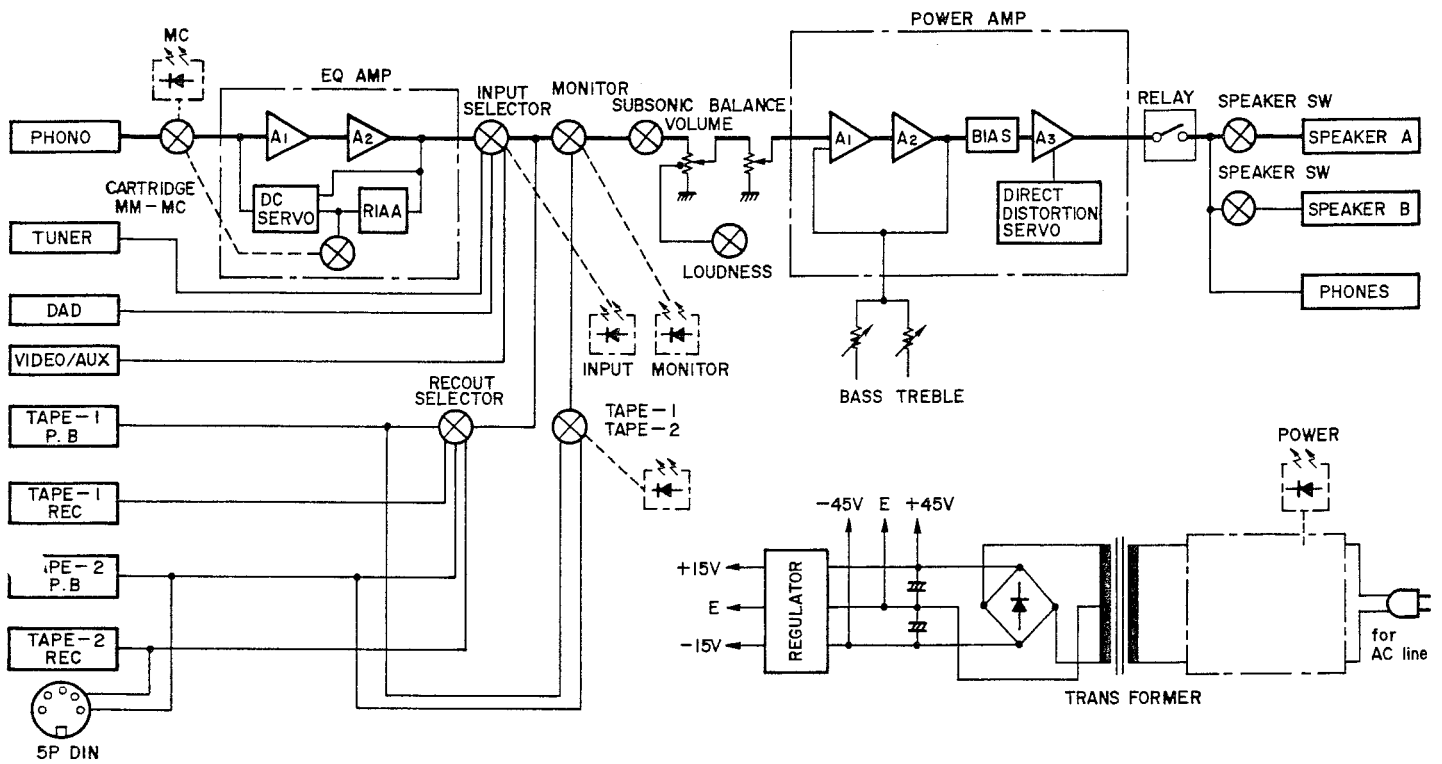

Fig. 4

## METHOD OF ADJUSTMENTS

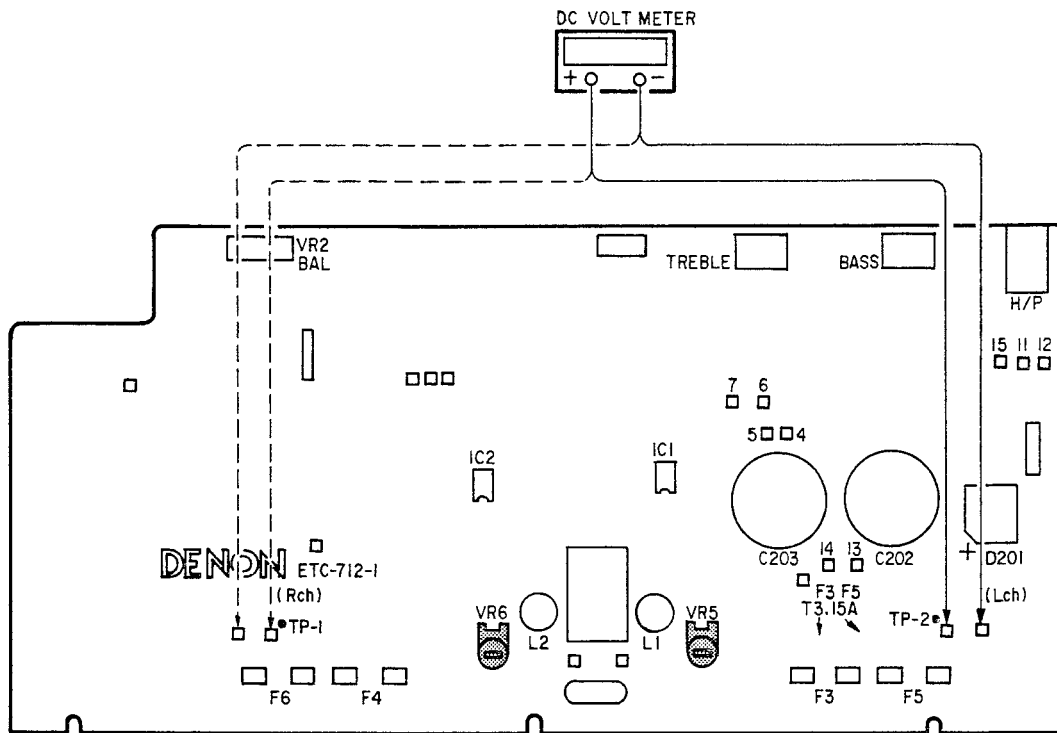



Fig. 5

## ADJUSTMENT

## IDLING CURRENT (Fig. 5)

## ● SETUP

1. Lay the unit at an ordinary position away from a direct current from a cooler or fan. Do the adjustment at a temperature between 15°C and 30°C.
2. Set controls as follows.
 

POWER SWITCH	→ off (  )
VOLUME CONTROL	→ fully counterclockwise. ( ∞ )
SPEAKER Terminals	→ open: do not connect the speakers, dummy load etc.

## ● Adjustment

1. Remove Top cover and turn VR5 (Lch) and VR6 (Rch) of ETC0712B (TONE & POWER Unit) fully counterclockwise. And then connect DC Voltmeter to Test point (Lch TP2, Rch TP1).
2. Connect Power cord to AC outlet, and turn Power Switch "on" (  ). Within 10 seconds turn VR5 and VR6 clockwise so that the DC voltmeter reads
 
$$1 \pm 0.5 \text{ mVDC}$$
3. Then after 10 ~ 15 minutes warmup adjust VR5 and VR6 so that the DC Voltmeter reads
 
$$16 \pm 2 \text{ mVDC}$$

## ETC0711 INPUT &amp; EQ. UNIT

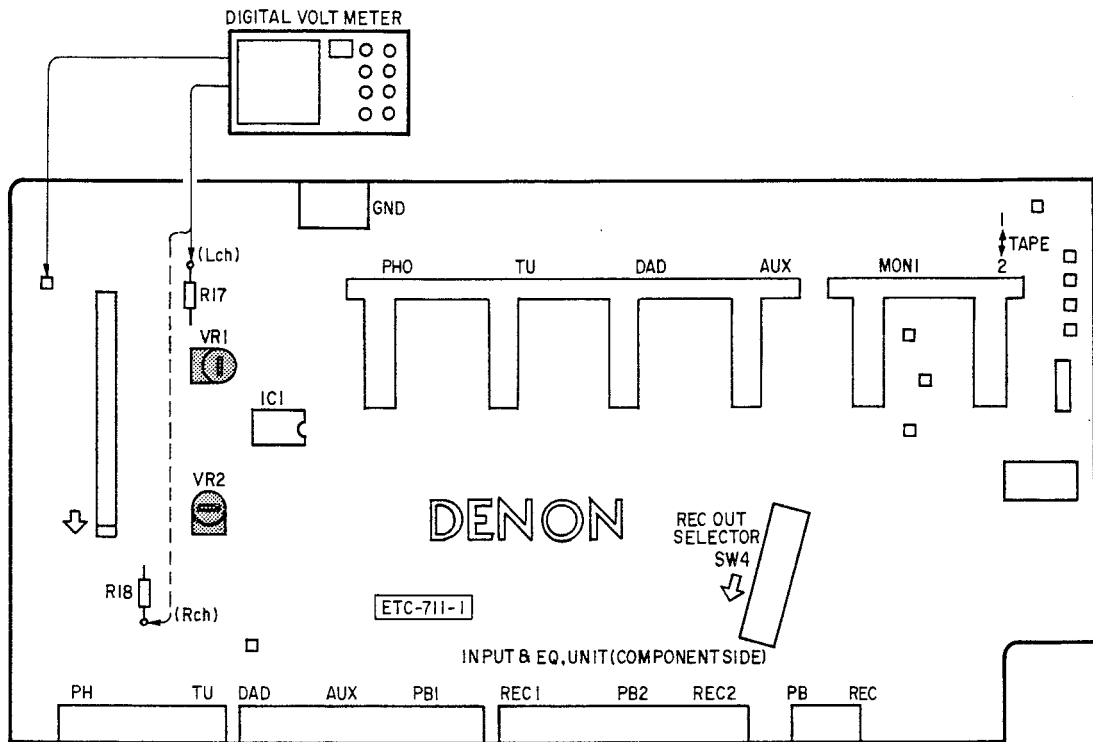

Fig. 6

## PHONO BALANCE (Fig. 6)

## ● Setup

1. Insert short-pin to "PHONO" input terminal.
2. Connect Digital Voltmeter (0.01 ~ 1 mVDC measurable) to "Test pin".
3. Connect Digital Voltmeter to Test point (Lch TP: R17, Rch TP: R18).
4. Set REC OUT SELECTOR to "source", INPUT SELECTOR to "PHONO" and Cartridge Switch to "MM" position, and turn Volume Control fully counterclockwise.

## ● Adjustment (Be sure to set REC OUT SELECTOR Switch to "source")

1. Turn Power switch "on ( )" and after about 2 minutes do the adjustment as follows.
  - Adjust VR1 (100Ω semi-fixed resistor) so that the Lch Digital Voltmeter reads below 0 VDC ±0.5 mVDC.
  - Adjust VR2 (100Ω semi-fixed resistor) so that the Rch Digital Voltmeter reads below 0 VDC ±0.5 mVDC.

SEMICONDUCTORS

- IC's  
M5218P  
(Mitsubishi)

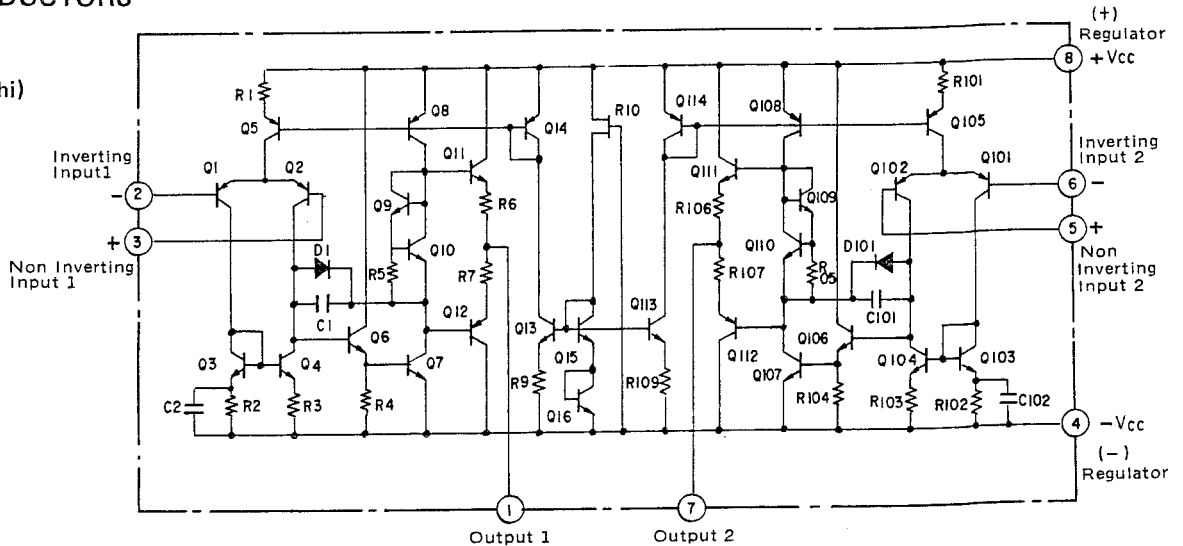
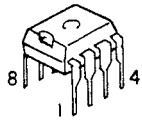

- TRANSISTORS (include FET)

2SC1841(E/F)  
2SC1815(BL)  
2SA1015(Y)

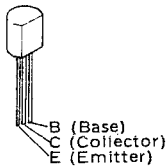

2SA1145(O/Y)  
2SC2705(O/Y)

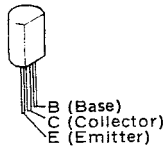

2SC2238(Y)...Black  
2SA968(Y)...Green

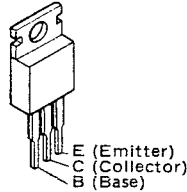

2SC2824(Y/O)

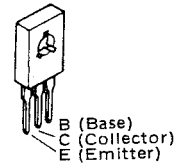

2SA850(D)/(E)  
2SC1735(D)/(E)

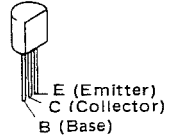

2SC1583(G)

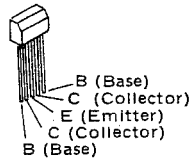

2SA1106(O)/(Y)  
2SC2581(O)/(Y)

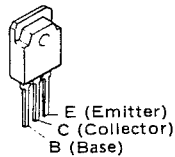

FET  
2SK373(Y)

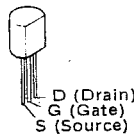

2SC2878(A/B)

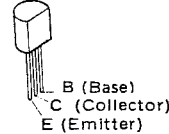

FET  
2SK389(BL)/(V)

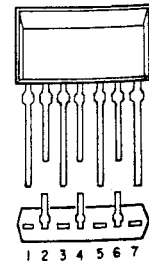

- DIODES (include LED, Thermistor & Posistor)

1S2076



HZ5C-1  
HZ15-2  
HZ16-2

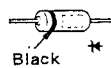

KB-265

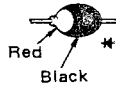

D5FB20...for E2, EK

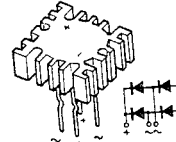

RB402ULF-F...for E1, E3

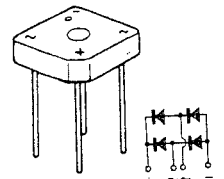

1S2076A

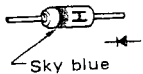

SEL1110R (Red)  
SEL1310G (Green)

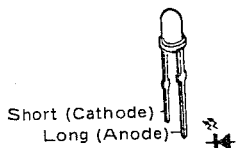

ID2C-1



PR5552K-1 (Red)

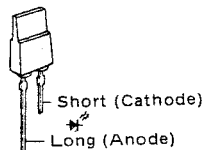

PTH487A01BD222TS

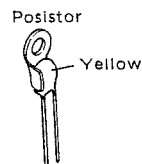



CONNECTION DIAGRAM  
(This figure is the specifications of E2.)

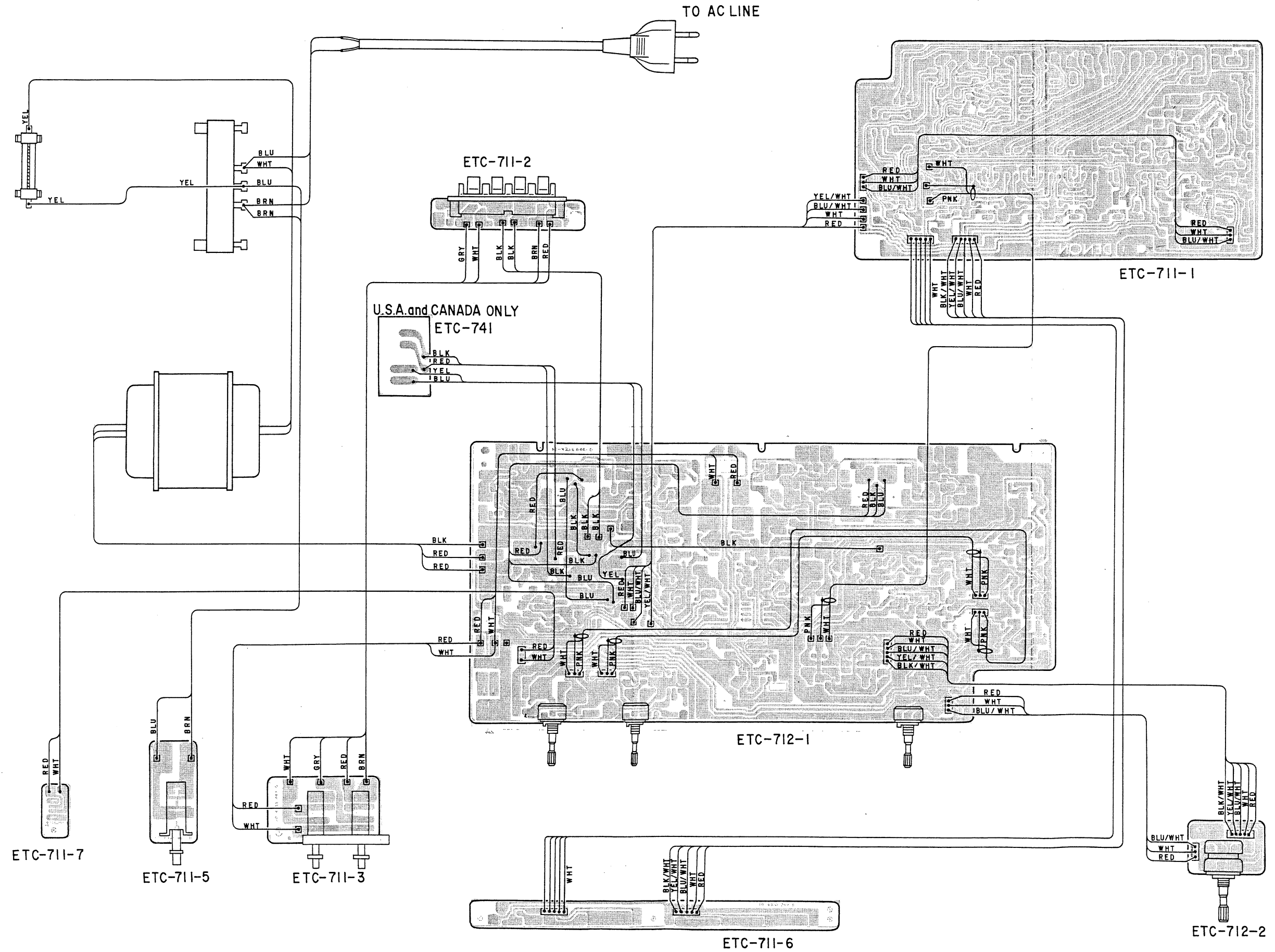

PRINTED WIRING BOARD PATTERNS AND PARTS LIST  
ETC0712B TONE & POWER UNIT

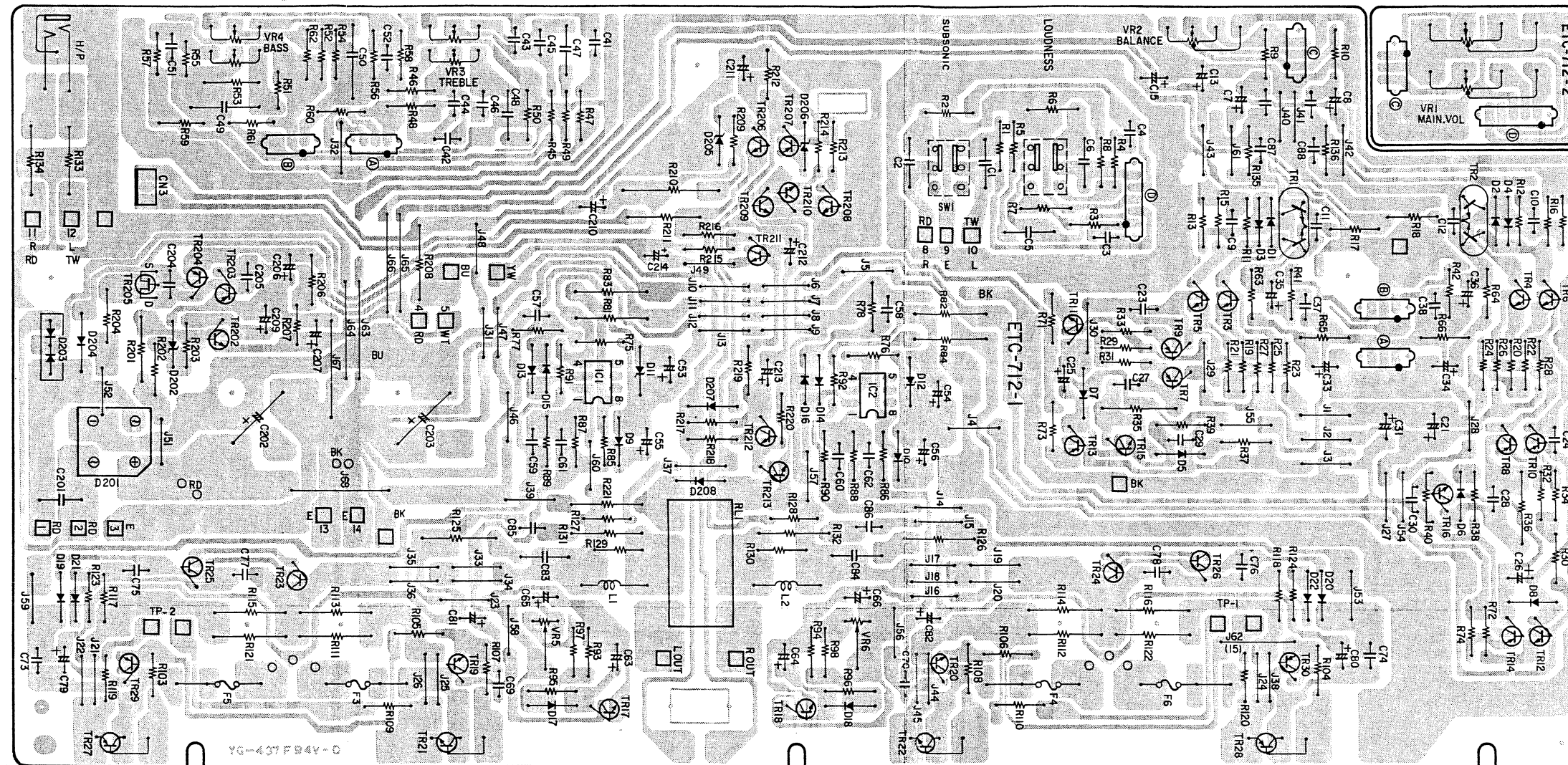

ETC0712C TONE & POWER UNIT for E3  
(Same as ETC0712B except the followings.)

Ref. No.	Part No.	Part Name & Descriptions
<b>SEMICONDUCTOR</b>		
D201	2760349009	RB402ULF-F (CHANGE)
<b>RESISTORS</b>		
R009, 010	2412092002	1k ohm ±5% 1/4W CARBON (CHANGE)
R111, ~116	2442013080	0.22 ohm ±5% 1W METAL OXIDE (N. B) (CHANGE)
R121, 122	2442013080	0.22 ohm ±5% 1W METAL OXIDE (N. B) (CHANGE)
<b>CAPACITORS</b>		
C011, 012	2533645008	560pF ±5% 50V CERAMIC (CHANGE)
C305, 306	2533635005	220pF ±5% 50V CERAMIC (DELETE)
C307, 308	2533645008	560pF ±5% 50V CERAMIC (DELETE)

Ref. No.	Part No.	Part Name & Descriptions
C311, 312	2531026001	0.047μF +80,-20% 50V CERAMIC (DELETE)
<b>OTHER PARTS</b>		
F003 ~006	2061039089	FUSE 3.15(A) (CHANGE)
R231, 232 (J61, J42)	2090008120	JUMPER (P=10mm) (CHANGE)

ETC0712D TONE & POWER UNIT for E1  
(Same as ETC0712B except the followings.)

Ref. No.	Part No.	Part Name & Descriptions
<b>SEMICONDUCTORS</b>		
D201	2760349009	RB402ULF-F (CHANGE)
<b>RESISTOR</b>		
R009, 010	2412092002	1k ohm ±5% 1/4W CARBON (CHANGE)
<b>CAPACITORS</b>		
C011, 012	2533645008	560pF ±5% 50V CERAMIC (CHANGE)
C305, 306	2533635005	220pF ±5% 50V CERAMIC (DELETE)
C307, 308	2533645008	560pF ±5% 50V CERAMIC (DELETE)
C311, 312	2531026001	0.047μF +80,-20% 50V CERAMIC (DELETE)
<b>OTHER PARTS</b>		
F003 ~006	2061035009	FUSE 3.15A(T) (CHANGE)
R231, 232 (J61, J42)	2090008120	JUMPER (P=10mm) (CHANGE)

ETC0712F TONE & POWER UNIT for EK  
(Same as ETC0712B except the followings.)

Ref. No.	Part No.	Part Name & Descriptions
R009, 010	2412092002	1k ohm ±5% 1/4W CARBON (CHANGE)
<b>CAPACITORS</b>		
C011, 012	2533645008	560pF ±5% 50V CERAMIC (CHANGE)
C305, 306	2533635005	220pF ±5% 50V CERAMIC (DELETE)
C307, 308	2533645008	560pF ±5% 50V CERAMIC (DELETE)
C311, 312	2531026001	0.047μF +80,-20% 50V CERAMIC (DELETE)
<b>OTHER PARTS</b>		
R231, 232 (J61, J42)	2090008120	JUMPER (P=10mm) (CHANGE)

ETC0712B TONE & POWER UNIT PARTS LIST for E2.

Ref. No.	Part No.	Part Name & Descriptions
<b>SEMICONDUCTORS</b>		
IC001, 002	2630257001	M5218P MITSUBISHI IC
TR001, 002	2730181006	2SC1583(G) TRANSISTOR
TR003 ~006	2730235020	2SC1841(E/F) TRANSISTOR
TR007 ~010	2710168007	2SA1145(O/Y) TRANSISTOR
TR011, 012	2730281003	2SC2705(O/Y) TRANSISTOR
TR013, 014	2710168007	2SA1145(O/Y) TRANSISTOR
TR015, 016	2730281003	2SC2705(O/Y) TRANSISTOR
TR017, 018	2730198015	2SC1815(BL) TRANSISTOR
TR019, 020	2730199001	2SC2238(Y) TRANSISTOR
TR023 ~026	2710102005	2SA1015(Y) TRANSISTOR
TR029, 030	2710104003	2SA968(Y) TRANSISTOR
TR202	2730163040	2SC1735(D)/(E) TRANSISTOR
TR203	2710102005	2SA1015(Y) TRANSISTOR
TR204	2710072025	2SA850(D)/(E) TRANSISTOR
TR205	2750042002	2SK373(Y) FET
TR206	2730236029	2SC2824(Y/O) TRANSISTOR
TR207	2710102005	2SA1015(Y) TRANSISTOR
TR208 ~210	2730198015	2SC1815(BL) TRANSISTOR
TR211	2730253015	2SC2878(A)/(B) TRANSISTOR
TR212	2730198015	2SC1815(BL) TRANSISTOR
TR213	2730235020	2SC1841(E/F) TRANSISTOR
D005, 006	2760049008	1S2076 DIODE
D007, 008	2760216019	KB-265 DIODE
D009 ~012	2760253001	HZ15-2 ZENER
D013 ~018	2760049008	1S2076 DIODE
D201	2760356005	D5FB20 DIODE
D202	2760256008	HZ-16-2 ZENER
D203	2760151006	1D2C-1 DIODE
D204	2760057016	V06C DIODE
D205	2760256008	HZ-16-2 ZENER
D206	2760236031	HZ5C-1 ZENER
D208	2760049011	1S2076A DIODE
<b>RESISTORS (not include Carbon Film ±5%, 1/4W Type)</b>		
R007, 008	2420203003	10M ohm ±10% 1/4W CARBON COMPOSIT
R023, 024	2412314036	750 ohm ±5% 1/4W CARBON (N.B)
R025 ~028	2412314023	470 ohm ±5% 1/4W CARBON (N.B)
R029, 030	2412314007	100 ohm ±5% 1/4W CARBON (N.B)
R035, 036	2440055024	15k ohm ±5% 1W METAL OXIDE(N.B)
R037 ~040	2412321045	220 ohm ±5% 1/4W CARBON (N.B)
R071 ~074	2412321061	47 ohm ±5% 1/4W CARBON (N.B)

Ref. No.	Part No.	Part Name & Descriptions
R075, 076	2412321003	1k ohm ±5% 1/4W CARBON (N.B)
R081 ~084	2440049027	4.7k ohm ±5% 1W METAL OXIDE (N.B)
R103, 104	2412321032	4.7 ohm ±5% 1/4W CARBON (N.B)
R105, 106	2412314007	100 ohm ±5% 1/4W CARBON (N.B)
R107, 108	2412321032	4.7 ohm ±5% 1/4W CARBON (N.B)
R111 ~116	2442013093	0.33 ohm ±5% 1W METAL OXIDE (N.B)
R121, 122	2442013093	0.33 ohm ±5% 1W METAL OXIDE (N.B)
R125, 126	2440017020	10 ohm ±5% 1W METAL OXIDE (N.B)
R133, 134	2440030023	120 ohm ±5% 1W METAL OXIDE (N.B)
R201	2440039024	680 ohm ±5% 1W METAL OXIDE (N.B)
R202	2410201002	4.7k ohm ±5% 1/2W CARBON
R204	2440039024	680 ohm ±5% 1W METAL OXIDE (N.B)
R208	2440037026	470 ohm ±5% 1W METAL OXIDE (N.B)
R209	2410205008	6.8k ohm ±5% 1/2W CARBON
R210	2440094027	470 ohm ±5% 2W METAL OXIDE (N.B)
R211	2440043023	1.5k ohm ±5% 1W METAL OXIDE (N.B)
R223, 224	2412321032	4.7 ohm ±5% 1/4W CARBON (N.B)
R221	2440037026	470 ohm ±5% 1W METAL OXIDE (N.B)
<b>CAPACITORS (not include Ceramic ±5%, ±10%, 50V Type)</b>		
C001, 002	2561030067	0.18μF ±5% 100V METALIZED
C005, 006	2551083008	0.082μF ±10% 50V PLASTIC FILM
C007, 008	2544146004	1μF 50V ELECTROLYTIC
C009, 010	2551120000	0.001μF ±5% 50V PLASTIC FILM
C013 ~015	2544146004	1μF 50V ELECTROLYTIC
C021, 022	2544181001	1μF ±20% 100V ELECTROLYTIC
C023, 024	2534277006	22pF ±0.25pF 500V CERAMIC
C025, 026	2544181001	1μF ±20% 100V ELECTROLYTIC
C027, 028	2554079048	0.01μF ±5% 100V PLASTIC FILM
C031, 033	2544181001	1μF ±20% 100V ELECTROLYTIC
C034, 035	2544127007	220μF 6.3V ELECTROLYTIC
C036, 037	2544132005	10μF 16V ELECTROLYTIC
C041, 042	2551121009	0.0068μF ±5% 50V PLASTIC FILM
C045, 046	2551120013	0.0012μF ±5% 50V PLASTIC FILM
C047, 048	2551122011	0.056μF ±5% 50V PLASTIC FILM
C049, 050	2551122095	0.27μF ±5% 50V PLASTIC FILM
C051, 052	2551121096	0.039μF ±5% 50V PLASTIC FILM

Ref. No.	Part No.	Part Name & Descriptions
C053 ~056	2544153000	47μF 50V ELECTROLYTIC
C063, 064	2544146004	1μF 50V ELECTROLYTIC
C065, 066	2544181001	1μF ±20% 100V ELECTROLYTIC
C069, 070	2534285001	47pF ±5% 500V CERAMIC
C073, 074	2534285001	47pF ±5% 500V CERAMIC
C079 ~082	2544181001	1μF ±20% 100V ELECTROLYTIC
C083, 084	2551084007	0.1μF ±10% 50V PLASTIC FILM
C201	2531053003	0.01μF +100,-0% 500V CERAMIC
C202, 203	2546067000	8200μF 56V ELECTROLYTIC
C206, 207	2544146004	1μF 50V ELECTROLYTIC
C209	2544153000	47μF 50V ELECTROLYTIC
C210	2544059007	100μF 63V ELECTROLYTIC
C211	2544146004	1μF 50V ELECTROLYTIC
C212	2544161034	330μF 6.3V ELECTROLYTIC
C213	2544129005	47μF 10V ELECTROLYTIC
C214	2544060067	3.3μF 100V ELECTROLYTIC
C311, 312	2531026001	0.047μF +80,-20% 50V CERAMIC
<b>COILS, RELAY</b>		
L001, 002	2350007007	INDUCTOR 1μH
RL001	2140041008	RELAY
<b>VARIABLE RESISTORS, SWITCH</b>		
VR001	2110425007	VARIABLE RESISTOR 100k ohm MAIN
VR002	2110198004	VARIABLE RESISTOR 250k ohm BALANCE
VR003	2110309107	VARIABLE RESISTOR 50k ohm TREBLE
VR004	2110309110	VARIABLE RESISTOR 100k ohm BASS
VR005	2116025087	SEMI FIXED RESISTOR 4.7k ohm
VR006	2124483006	2P PUSH SWITCH LOUD/SUB SONIC
<b>OTHER PARTS</b>		
F003 ~006	2221061208 2090008120 EP-5667H2  2090008162 2090008104 2061015074  2020022008 2048047007 2030170005 2050190036 2050185038 2050185054 4450033005	P.W. BOARD JUMPER P=10mm USED 62 TERMINAL (WRAPPING PIN) USED 23  JUMPER P=20mm USED 6 JUMPER P=15mm USED 1 FUSE 3.15A USED 4  FUSE HOLDER USED 8 H/P JACK 1P CONTACT 3P NH CONNECTOR BASE 3P WIRE HOLDER USED 6 5P WIRE HOLDER USED 2 WIRE CLAMP BAND USED 4

ETC0741 C-UNIT for E3 only

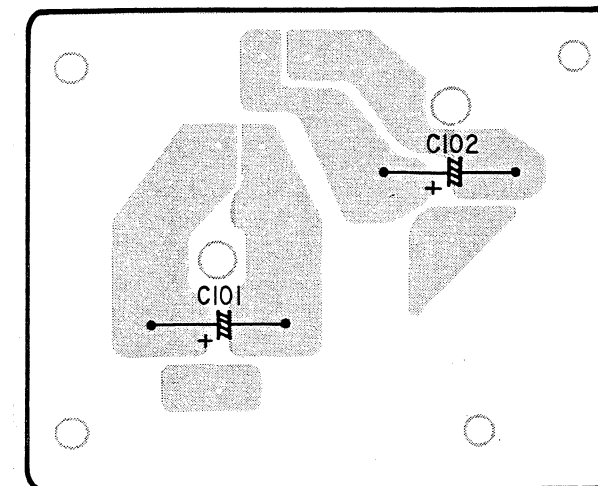

ETC0741 C-UNIT PARTS LIST

Ref. No.	Part No.	Part Name & Descriptions
<b>CAPACITORS</b>		
C101, 102	2546089004	8200μF 56V ELECTROLYTIC
<b>OTHER PARTS</b>		
	2221089002 EP-5667H3	P.W. BOARD TERMINAL (WRAPPING PIN) USED 4



ETC0711 INPUT & EQ UNIT

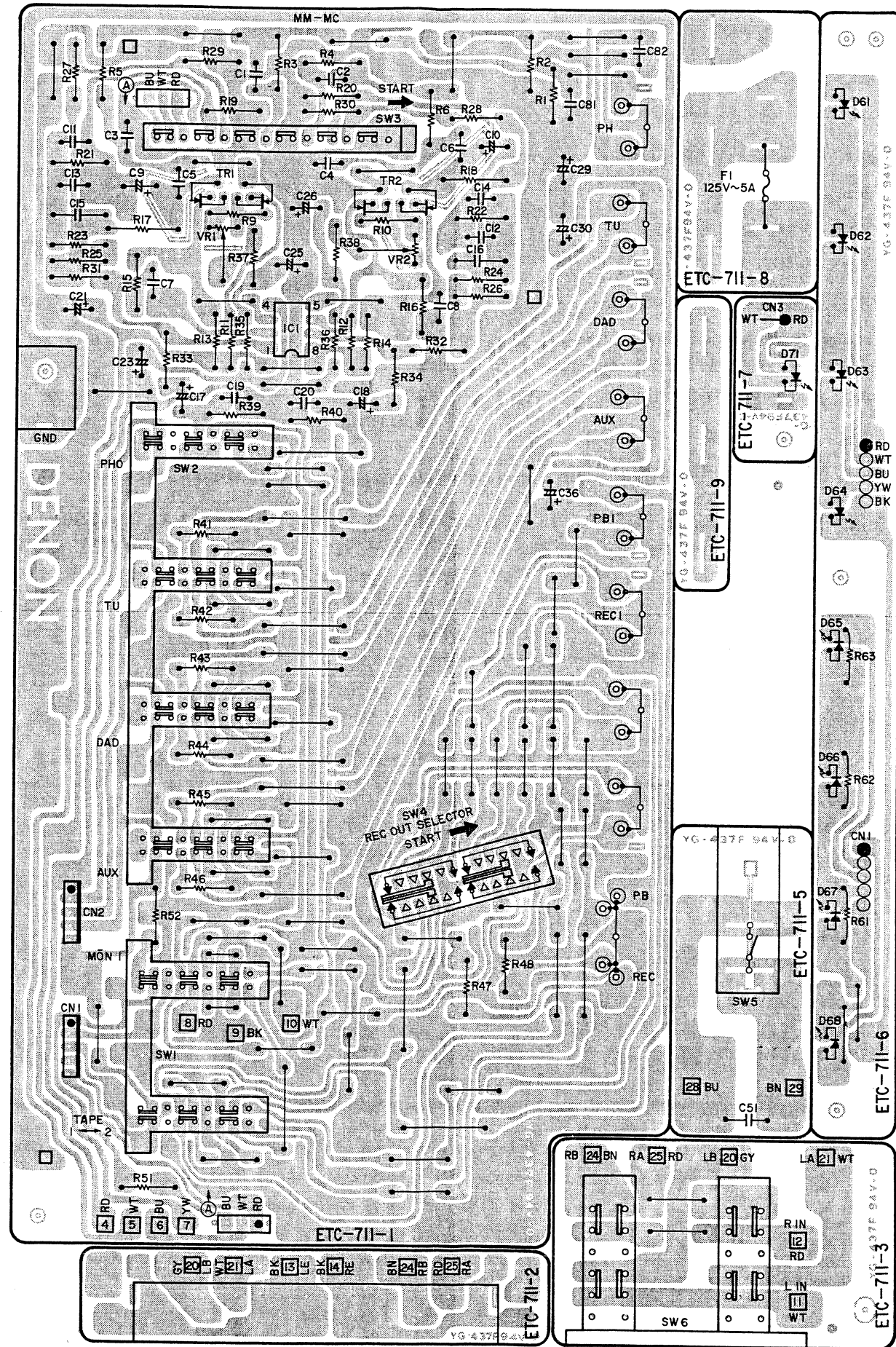

ETC0711 INPUT & EQ UNIT PARTS LIST for E2.

Ref. No.	Part No.	Part Name & Descriptions
<b>SEMICONDUCTORS</b>		
IC001	2630257001	M5218P MITSUBISHI IC
TR001, 002	2750045009	2SK389(BL)/(V) FET
D061 ~064	3939052003	SEL1310G GREEN LED
D065 ~067	3939051004	SEL1110R RED LED
D068	3939052003	SEL1310G GREEN LED
D071	3939154008	PR5552K-1 RED LED
<b>RESISTORS (not include Carbon Film ±5%, 1/4W Type)</b>		
R017, 018	2420203003	10M ohm ±10% 1/4W CARBON COMPOSIT
R035, 036	2412370041	2k ohm ±5% 1/4W CARBON (N.B)
<b>CAPACITORS (not include Ceramic ±5%, ±10%, 50V Type)</b>		
C001, 002	2531024003	0.01μF +80,-20% 50V CERAMIC
C007, 008	2551120084	0.0047μF ±5% 50V PLASTIC FILM
C009, 010	2549011024	10μF 50V ELECTROLYTIC
C011, 012	2551120013	0.0012μF ±5% 50V PLASTIC FILM
C013, 014	2551121041	0.015μF ±5% 50V PLASTIC FILM
C015, 016	2551122011	0.056μF ±5% 50V PLASTIC FILM
C017, 018	2544164015	10μF 25V ELECTROLYTIC
C019, 020	2551120068	0.0033μF ±5% 50V PLASTIC FILM
C021, 023, 036	2544146004	1μF 50V ELECTROLYTIC
C025, 026	2544135002	47μF 16V ELECTROLYTIC
C029, 030	2544146004	1μF 50V ELECTROLYTIC
C051	2538003014	0.0047μF ±20% 400V CERAMIC
C301, 302	2531026001	0.047μF +80,-20% 50V CERAMIC
<b>VARIABLE RESISTORS</b>		
VR001, 002	2116025016	SEMI FIXED RESISTOR 100 ohm
<b>SWITCHES</b>		
SW001	2124488001	2P PUSH SWITCH TAPE MONITOR
SW002	2124487002	4P PUSH SWITCH INPUT SEL.
SW003	2124485004	SLIDE SWITCH (6-2) REMOTE MM/MC
SW004	2124187001	SLIDE SWITCH (4-4) REMOTE REC OUT
SW005	2124154063	POWER SWITCH
SW006	2124486003	2P PUSH SWITCH SP

Ref. No.	Part No.	Part Name & Descriptions
<b>OTHER PARTS</b>		
L001, 002 (J7,J5)	2221060	P.W. BOARD
	2090008120	JUMPER P=10mm USED 60
	EP-5667H2	TERMINAL (WRAPPING PIN) USED 24
	2350009018	INDUCTOR 2.2μH
	2090008146	JUMPER WIRE P=5mm USED 2
	2090008104	JUMPER WIRE P=15mm USED 14
	2050185038	3P WIRE HOLDER USED 2
	2050136032	5P CONNECTOR BASE
	2050190052	5P NH CONNECTOR BASE
	4140240001	EARTH PLATE
1220109007	BLIND SHEET	
4410412200	LED HOLDER	
2048059008	DIN JACK (5P)	
2050151004	8P PUSH TERMINAL FOR SP.	
2050150005	4P CONNECTOR BASE	
2050152003	6P CONNECTOR BASE USED 2	
2034185083	3P CONNECTOR CORD	
2038132003	5P CONNECTOR CORD	

**ETC0711B INPUT & EQ. UNIT PARTS LIST for E3**  
(Same as ETC0711 except the followings.)

Ref. No.	Part No.	Part Name & Descriptions
<b>CAPACITORS</b>		
C001, 002	2531024003	0.01 $\mu$ F +80,-20% 50V CERAMIC (DELETE)
C003, 004	2533635005	220pF $\pm$ 5% 50V CERAMIC (CHANGE)
C051	2568019007	0.01 $\mu$ F $\pm$ 20% 125V METALIZED (CHANGE)
C061, ~064	2531009002	0.0068 $\mu$ F $\pm$ 10% 50V CERAMIC (DELETE)
C081, 082	2533635005	220pF $\pm$ 5% 50V CERAMIC (DELETE)
C083 ~092	2533627000	100pF $\pm$ 5% 50V CERAMIC (DELETE)
C301, 302	2531026001	0.047 $\mu$ F +80,-20% 50V CERAMIC (DELETE)
C303, 304	2533645008	560pF $\pm$ 5% 50V CERAMIC (DELETE)
C309, 310	2531005006	0.0015 $\mu$ F $\pm$ 10% 50V CERAMIC (DELETE)

Ref. No.	Part No.	Part Name & Descriptions
<b>SWITCH</b>		
SW005	2124154034	PUSH SWITH (CHANGE)
<b>OTHER PARTS</b>		
L001, 002 (J7,J5)	2048059008 EP-5667H2	DIN JACK (5P) (CHANGE) TERMINAL (WRAPPING PIN) (ADD)
	EP-5870	FUSE HOLDER (ADD)
	2090008120	JUMPER P=10mm (CHANGE)

**ETC0711D INPUT & EQ. UNIT PARTS LIST for E1.**  
(Same as ETC0711 except the followings.)

Ref. No.	Part No.	Part Name & Descriptions
<b>CAPACITORS</b>		
C001, 002	2531024003	0.01 $\mu$ F +80,-20% 50V CERAMIC (DELETE)
C003, 004	2533635005	220pF $\pm$ 5% 50V CERAMIC (CHANGE)
C061 ~064	2531009002	0.0068 $\mu$ F $\pm$ 10% 50V CERAMIC (DELETE)
C081, 082	2533635005	220pF $\pm$ 5% 50V CERAMIC (DELETE)
C083 ~092	2533627000	100pF $\pm$ 5% 50V CERAMIC (DELETE)
C301, 302	2531026001	0.047 $\mu$ F +80,-20% 50V CERAMIC (DELETE)

Ref. No.	Part No.	Part Name & Descriptions
C303, 304	2533645008	560pF $\pm$ 5% 50V CERAMIC (DELETE)
C309, 310	2531005006	0.0015 $\mu$ F $\pm$ 10% 50V CERAMIC (DELETE)
<b>OTHER PARTS</b>		
L001, 002 (J7,J5)	EP-5667H2	TERMINAL (WRAPPING PIN) (ADD)
	2048059008 EP-5870	DIN JACK (5P) (DELETE) FUSE HOLDER (ADD)
	2090008120	JUMPER P=10mm (CHANGE)

**ETC0711F INPUT & EQ. UNIT PARTS LIST for EK**  
(Same as ETC0711 except the followings.)

Ref. No.	Part No.	Part Name & Descriptions
<b>CAPACITORS</b>		
C001, 002	2531024003	0.01 $\mu$ F +80,-20% 50V CERAMIC (DELETE)
C003, 004	2533635005	220pF $\pm$ 5% 50V CERAMIC (CHANGE)
C061 ~064	2531009002	0.0068 $\mu$ F $\pm$ 10% 50V CERAMIC (DELETE)
C081, 082	2533635005	220pF $\pm$ 5% 50V CERAMIC (DELETE)
C083 ~092	2533627000	100pF $\pm$ 5% 50V CERAMIC (DELETE)

Ref. No.	Part No.	Part Name & Descriptions
C301, 302	2531026001	0.047 $\mu$ F +80,-20% 50V CERAMIC (DELETE)
C303, 304	2533645008	560pF $\pm$ 10% 50V CERAMIC (DELETE)
C309, 310	2531005006	0.0015 $\mu$ F $\pm$ 10% 50V CERAMIC (DELETE)
<b>OTHER PARTS</b>		
L001, 002 (J7,J5)	2090008120	JUMPER P=10mm (CHANGE)

## ADDENDUM LIST (Ref. number 100 or older onto in the EXPLODED VIEW.)

Ref. No.	Part Name & Descriptions	Part No.		
		E3 for U.S.A.	EK for U.K.	E1 for Asia
1	BACK PANEL	1050603003	1050601102	1050609007
3	SP TERMINAL UNIT	ETC0711B2	ETC0711F2	ETC0711D2
△ 4	AC CORD	2062021009	2062020000	2006031026
△ 5	CORD BUSH	4450020005	MD-2982H	MD-3802
6	INSULATING SHEET	—	4150088004	—
7	7P W TERMINAL	—	2050089008	—
8	FUSE HOLDER	—	2020013101	2020013101
△ 9	FUSE	—	2061015032 (2.5A)	2061015032 (2.5A)
10	FUSE LABEL	—	5130654017	5130654017
△ 11	CAPACITOR	2568019007	—	2568003000
12	FTZ LABEL	—	—	—
15	RADIATOR	4170226118	4170226105	4170226105
28	POWER SWITCH UNIT	ETC0711B5	ETC0711F5	ETC0711D5
29	SPEAKER SWITCH UNIT	ETC0711B3	ETC0711F3	ETC0711D3
30	TONE & POWER UNIT	ETC0712C	ETC0712F	ETC0712D
31	VOLUME UNIT	ETC0712C2	ETC0712F2	ETC0712D2
35	INPUT & EQ. UNIT	ETC0711B	ETC0711F	ETC0711D
△ 37	POWER TRANS	2335486009	2335468001	2335466003
48	INPUT LED UNIT	ETC0711B6	ETC0711F6	ETC0711D6
49	POWER LED UNIT	ETC0711B7	ETC0711F7	ETC0711D7
55	TOP COVER	(1020148019)	1020148019	1020148019
57	SPACER	(1220069008)	1220069008	1220069008
△ 100	AC OUTLET (3P)	2033922001	—	2033922001
△ 101	AC OUTLET UNIT	ETC0711B8	—	ETC0711D8
△ 102	AC OUTLET UNIT	ETC0711B9	—	ETC0711D9
103	DANGEROUS MARK	5138266009	—	—
104	SERIAL NO. PLATE	5130675096	—	—
105	RIVET	4770126016	—	—
106	EARTH LABEL	—	5130140000	—
107	VOLTAGE LABEL	—	5130362008	—
108	BLIND SHEET	—	5130348006	—
109	CAUTION SHEET	—	5130364006	—
△ 110	VOLTAGE SEL. SWITCH	—	—	2120186006
111	PRESET LABEL	—	—	5150290008
112	FUSE LABEL	5130607080	—	—
113	FUSE	2061023079	—	2061026005
114	FUSE LABEL	5130607006	—	—
115	P.C.B. BRACKET	4121669009	—	—
116	C-UNIT	ETC0741	—	—
117	PLATE (L)	4410452008	—	—
118	PLATE (R)	4410453007	—	—
119	SPACER	1220069040	—	—
<b>SCREWS and NUTS (included Washers)</b>				
303	PAN SCREW WITH S.W 3x8 (BK)	—	4700042005	4700042005
304	NUT M3	—	4756006008	—
318	TOOTH WASHER φ3	—	4753001051	—
319	TOOTH WASHER φ4	—	4753100004	—
320	3T LUG	—	—	—
<b>PACKING &amp; ACCESSORIES</b>				
d.	INST. MANUAL	5111247003	5111213008	5111213008
e.	SAFETY INSTRUCTION	5111041005	—	—
f.	WARRANTY IN ENVELOPE	5158053001	—	5158053001
g.	IMPORTANT LABEL	—	5130372001	—

IRING DIAGRAM

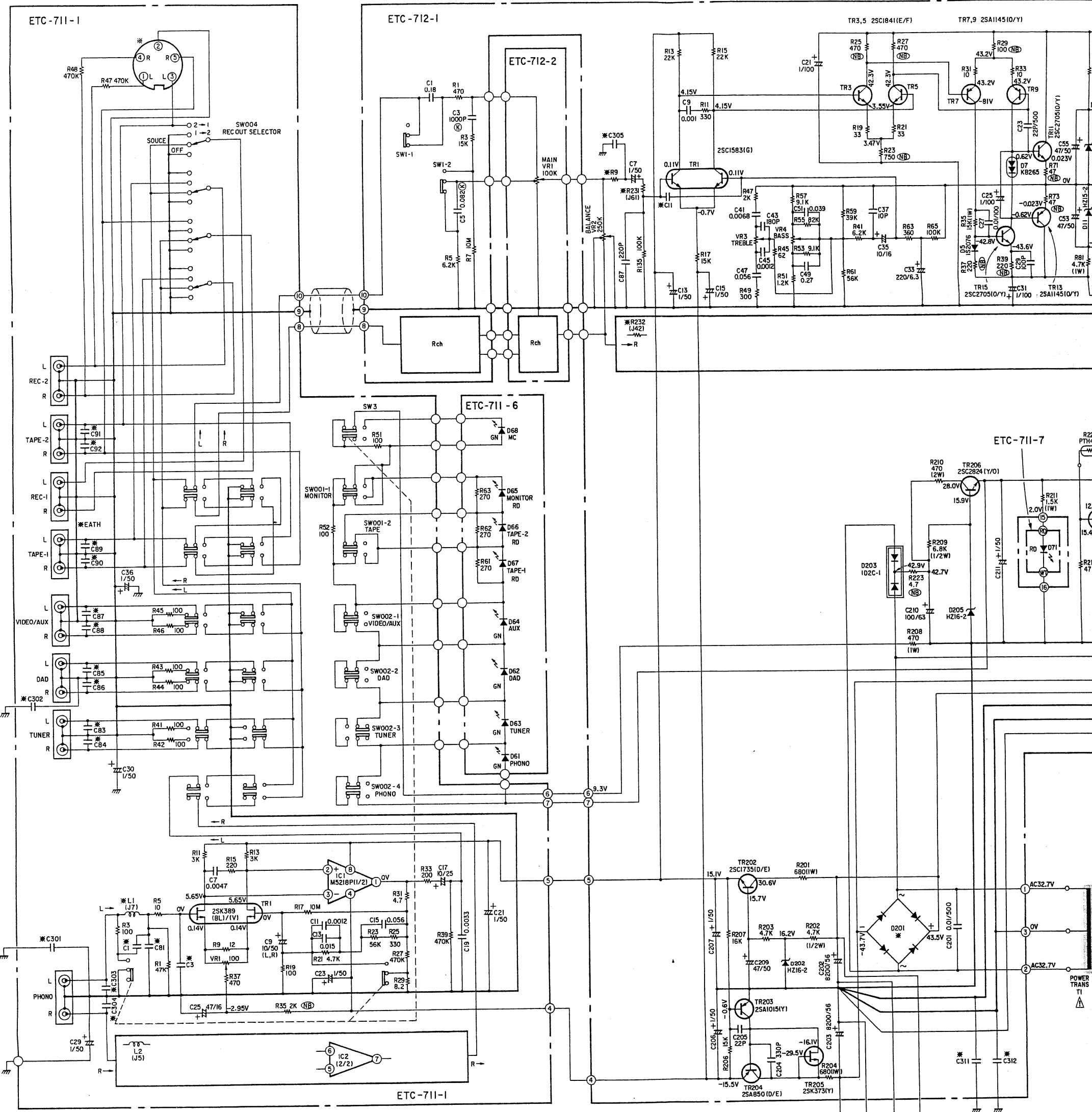

UNIT	ETC-711										ETC-712									
	(J7, J5) L1, 2	C1, 2	C3, 4	C81, 82	C83 ~ 92	C301, 302	C303, 304	C309, 310	C61 ~ 64	5P DIN	R9, 10	(J61, J42) R231, 232	C305, 306	C11, 12	C307, 308	C311, 312	D201	R111 ~ 116 R121, 122		
PMA737E2	2.2μH	CK 0.01μF (Z)	CC 560P	CC 220P	CC 100P	CK 0.047μF (Z)	CC 560P	CK 0.0015μF	CK 0.0068μF	USED	470Ω	1KΩ	CC 220P	CC 220P	CC 560P	CK 0.047μF (Z)	D5F820	0.33Ω (1W)		
E3	JUMPER	—	CC 220P	—	—	—	—	—	—	—	1KΩ	JUMPER	—	CC 560P	—	—	RB402ULF	0.22Ω (1W)		
E1	JUMPER	—	CC 220P	—	—	—	—	—	—	—	1KΩ	JUMPER	—	CC 560P	—	—	RB402ULF	0.33Ω (1W)		
EK	JUMPER	—	CC 220P	—	—	—	—	—	—	USED	1KΩ	JUMPER	—	CC 560P	—	—	D5F820	0.33Ω (1W)		
EC	JUMPER	—	CC 220P	—	—	—	—	—	—	—	1KΩ	JUMPER	—	CC 560P	—	—	RB402ULF	0.22Ω (1W)		

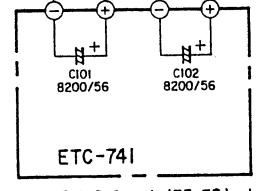

ETC-741  
For U.S.A. & Canada (E3, EC) only







⚠ Means important safety item, which must be replaced, when necessary, by a part specified or meeting the specification by the manufacturer.

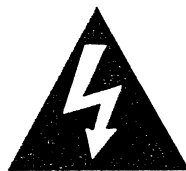
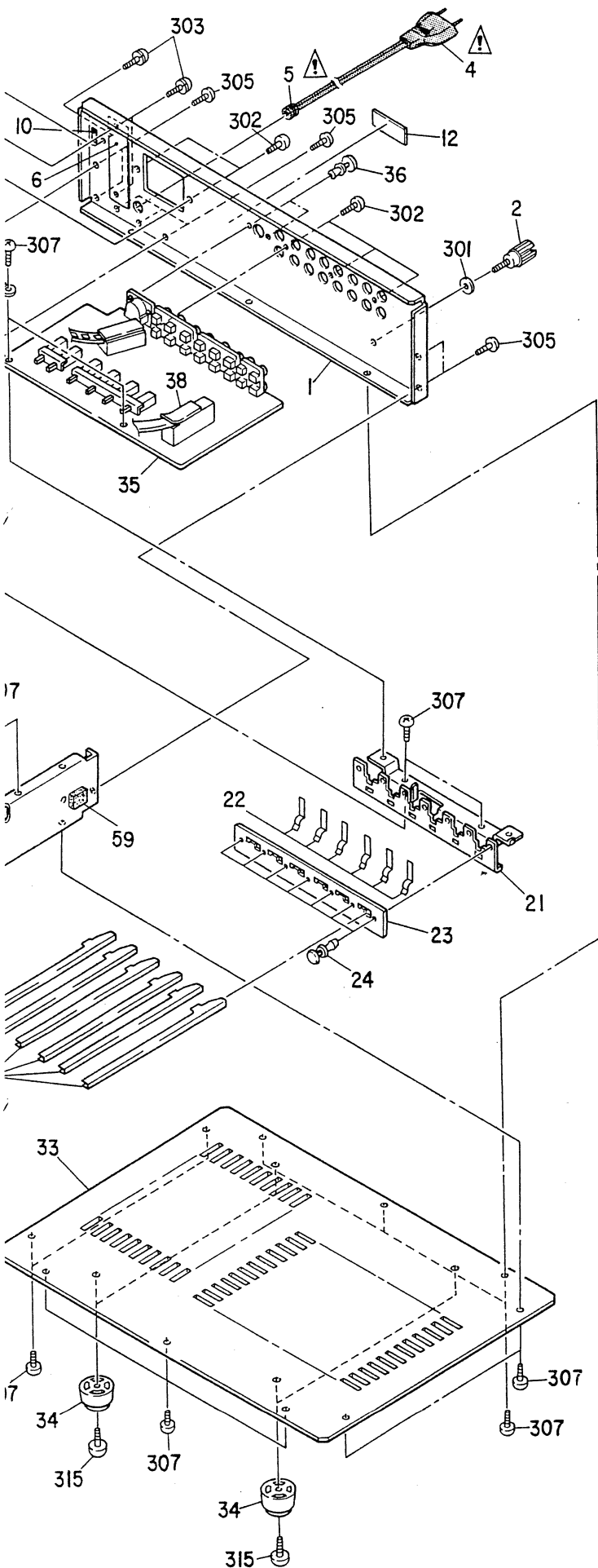

## CAUTION

RISK OF ELECTRIC SHOCK  
DO NOT OPEN



CAUTION: TO REDUCE THE RISK OF ELECTRIC SHOCK, DO NOT REMOVE COVER (OR BACK). NO USER SERVICEABLE PARTS INSIDE. REFER SERVICING TO QUALIFIED SERVICE PERSONNEL.



The lightning flash with arrowhead symbol within an equilateral triangle is intended to alert the user of the presence of uninsulated "dangerous voltage" within the product's enclosure that may be of sufficient magnitude to constitute a risk of electric shock to persons.



The exclamation point within an equilateral triangle is intended to alert the user of the presence of important operating and maintenance (servicing) instructions in the literature accompanying the appliance.

"SERIAL NO. \_\_\_\_\_  
PLEASE RECORD UNIT SERIAL NUMBER ATTACHED TO THE REAR OF THE CABINET FOR FUTURE REFERENCE"

**NIPPON COLUMBIA CO., LTD.**  
No. 14-14, 4-CHOME AKASAKA,  
MINATO-KU, TOKYO 107 JAPAN  
TEL: 03-584-8111  
TLX: JAPANOLA J22591  
CABLE: NIPPONCOLUMBIA TOKYO

Printed

cluded in the list. See Page 14.

Ref. No.	Part No.	Part Name & Descriptions	Q'ty	Ref. No.	Part No.	Part Name & Descriptions
<b>SCREWS and NUTS (included Washers)</b>				<b>PACKING &amp; ACCESSORIES (not include EXPLODED VIEW)</b>		
301	4770018001	WASHER (P-87)	1	a.	5040064001	CABINET SHEET
302	4730354035	TAPPING SCREW (2) 3x8	5	b.	5030262101	CUSHION
*303	4700042005	PAN SCREW WITH SW 3x8 (BK)	3	c.	5010916024	CARTON CASE
*304	4756006008	NUT M3	3	*d.	5111213008	INST. MANUAL
305	4770064107	FIXING SCREW	7			
306	4700012022	PAN SCREW WITH W.SPW 3x12	5			
307	4730354019	TAPPING SCREW (2) 3x8	31			
308	-	WASHER φ9 (SP)	1			
309	-	NUT M9 (SP)	1			
310	4711303018	PAN SCREW 3x6	8			
311	-	NUT M7 (SP)	3			
312	-	NUT M12 (SP)	1			
313	-	NUT M8 (SP)	1			
314	4700026005	TAPPING SCREW WITH W3x8	2			
315	4730455015	TAPPING SCREW (2) 4x10	4			
316	4770231008	WASHER φ4 (S)	1			
317	4734801005	TAPPING SCREW (TRUS) 4x8	4			
*320	2050003107	3T LUG	1			
321	4718005005	TAPPING SCREW WITH W. SPW 4x10	4			

The BLACK VERSION is equal to the GOLD VERSION except for the following items.

Ref. No.	Part No.	Part Name & Descriptions
40	1130515024	PUSH KNOB (A) FOR POWER
42	1441222213	FRONT PANEL ASS'Y
43	1460682229	WINDOW PANEL
45	1430361017	WINDOW
46	1449001012	ESC PLATE
47	1130513220	PUSH KNOB (B) ASS'Y
51	1130579112	PUSH KNOB (C) FOR INPUT
53	1120449016	KNOB (A) FOR MAIN
54	1120450018	KNOB (B) FOR BAL, SEL, BASS, TREBLE
55	1020148022	TOP COVER
<b>SCREWS and NUTS</b>		
317	4734454038	TAPPING SCREW (2) 4x8
<b>PACKING &amp; ACCESSORIES</b>		
a	5040052013	CABINET COVER
c	5010915083	CARTON CASE

# DENON



## CAUTION

RISK OF ELECTRIC SHOCK  
DO NOT OPEN

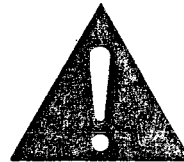

**CAUTION: TO REDUCE THE RISK OF ELECTRIC SHOCK, DO NOT REMOVE COVER (OR BACK). NO USER SERVICEABLE PARTS INSIDE. REFER SERVICING TO QUALIFIED SERVICE PERSONNEL.**



The lightning flash with arrowhead symbol within an equilateral triangle is intended to alert the user of the presence of uninsulated "dangerous voltage" within the product's enclosure that may be of sufficient magnitude to constitute a risk of electric shock to persons.



The exclamation point within an equilateral triangle is intended to alert the user of the presence of important operating and maintenance (servicing) instructions in the literature accompanying the appliance.

"SERIAL NO. \_\_\_\_\_"

PLEASE RECORD UNIT SERIAL NUMBER ATTACHED TO THE REAR OF THE CABINET FOR FUTURE REFERENCE"

**NIPPON COLUMBIA CO., LTD.**

No. 14-14, 4-CHOME AKASAKA,  
MINATO-KU, TOKYO 107 JAPAN

TEL: 03-584-8111

TLX: JAPANOLA J22591

CABLE: NIPPONCOLUMBIA TOKYO