

SERVICE MANUAL

MODEL	JP	E3	E2	EK	E2A	E1C	E1K	EUT
POA-3012CI		✓	✓					

STEREO POWER AMPLIFIER

注 意

サービスをおこなう前に、このサービスマニュアルを必ずお読みください。本機は、火災、感電、けがなどに対する安全性を確保するために、さまざまな配慮をおこなっており、また法的には「電気用品安全法」にもとづき、所定の許可を得て製造されています。従ってサービスをおこなう際は、これらの安全性が維持されるよう、このサービスマニュアルに記載されている注意事項を必ずお守りください。

● For purposes of improvement, specifications and design are subject to change without notice.

● 本機の仕様は性能改良のため、予告なく変更することがあります。
● 補修用性能部品の保有期間は、製造打切後 8 年です。

● Please use this service manual with referring to the operating instructions without fail.

● 修理の際は、必ず取扱説明書を参照の上、作業を行ってください。

● Some illustrations using in this service manual are slightly different from the actual set.

● 本文中に使用しているイラストは、説明の都合上現物と多少異なる場合があります。

DENON

Denon Brand Company, D&M Holdings Inc.

SAFETY PRECAUTIONS

The following check should be performed for the continued protection of the customer and service technician.

LEAKAGE CURRENT CHECK

Before returning the unit to the customer, make sure you make either (1) a leakage current check or (2) a line to chassis resistance check. If the leakage current exceeds 0.5 milliamps, or if the resistance from chassis to either side of the power cord is less than 460 kohms, the unit is defective.

CAUTION Please heed the points listed below during servicing and inspection.

⊙ Heed the cautions!

Spots requiring particular attention when servicing, such as the cabinet, parts, chassis, etc., have cautions indicated on labels or seals. Be sure to heed these cautions and the cautions indicated in the handling instructions.

⊙ Caution concerning electric shock!

- (1) An AC voltage is impressed on this set, so touching internal metal parts when the set is energized could cause electric shock. Take care to avoid electric shock, by for example using an isolating transformer and gloves when servicing while the set is energized, unplugging the power cord when replacing parts, etc.
- (2) There are high voltage parts inside. Handle with extra care when the set is energized.

⊙ Caution concerning disassembly and assembly!

Though great care is taken when manufacturing parts from sheet metal, there may in some rare cases be burrs on the edges of parts which could cause injury if fingers are moved across them. Use gloves to protect your hands.

⊙ Only use designated parts!

The set's parts have specific safety properties (fire resistance, voltage resistance, etc.). For replacement parts, be sure to use parts which have the same properties. In particular, for the important safety parts that are marked \triangle on wiring diagrams and parts lists, be sure to use the designated parts.

⊙ Be sure to mount parts and arrange the wires as they were originally!

For safety reasons, some parts use tape, tubes or other insulating materials, and some parts are mounted away from the surface of printed circuit boards. Care is also taken with the positions of the wires inside and clamps are used to keep wires away from heating and high voltage parts, so be sure to set everything back as it was originally.

⊙ Inspect for safety after servicing!

Check that all screws, parts and wires removed or disconnected for servicing have been put back in their original positions, inspect that no parts around the area that has been serviced have been negatively affected, conduct an insulation check on the external metal connectors and between the blades of the power plug, and otherwise check that safety is ensured.

(Insulation check procedure)

Unplug the power cord from the power outlet, disconnect the antenna, plugs, etc., and turn the power switch on. Using a 500V insulation resistance tester, check that the insulation resistance between the terminals of the power plug and the externally exposed metal parts (antenna terminal, headphones terminal, microphone terminal, input terminal, etc.) is $1M\Omega$ or greater. If it is less, the set must be inspected and repaired.

CAUTION Concerning important safety parts

Many of the electric and structural parts used in the set have special safety properties. In most cases these properties are difficult to distinguish by sight, and using replacement parts with higher ratings (rated power and withstand voltage) does not necessarily guarantee that safety performance will be preserved. Parts with safety properties are indicated as shown below on the wiring diagrams and parts lists in this service manual. Be sure to replace them with parts with the designated part number.

- (1) Schematic diagrams ... Indicated by the \triangle mark.
- (2) Parts lists ... Indicated by the \triangle mark.

Using parts other than the designated parts could result in electric shock, fires or other dangerous situations.

注意 サービス、点検時にはつぎのことにご注意願います。

◎注意事項をお守りください！

サービスのとき特に注意を必要とする個所についてはキャビネット、部品、シャーシなどにラベルや捺印で注意事項を表示しています。これらの注意書きおよび取扱説明書などの注意事項を必ずお守りください。

◎感電に注意！

- (1) このセットは、交流電圧が印加されていますので通電時に内部金属部に触れると感電することがあります。従って通電サービス時には、絶縁トランスの使用や手袋の着用、部品交換には、電源プラグを抜くなどして感電にご注意ください。
- (2) 内部には高電圧の部分がありますので、通電時の取扱には十分ご注意ください。

◎分解、組み立て作業時のご注意！

板金部品の端面の『バリ』は、部品製造時に充分管理しておりますが、板金端面は鋭利となっている箇所がありますので、部品端面に触れたまま指を動かすとまれに怪我をする場合がありますので十分注意して作業して下さい。手の保護のために手袋を着用してください。

◎指定部品の使用！

セットの部品は難燃性や耐電圧など安全上の特性を持ったものとなっています。従って交換部品は、使用されていたものと同じ特性の部品を使用してください。特に配線図、部品表に△印で指定されている安全上重要な部品は必ず指定のものをご使用ください。

◎部品の取付けや配線の引きまわしは、元どおりに！

安全上、テープやチューブなどの絶縁材料を使用したり、プリント基板から浮かして取付けた部品があります。また内部配線は引きまわしやクランパーによって発熱部品や高圧部品に接近しないように配慮されていますので、これらは必ず元どおりにしてください。

◎サービス後は安全点検を！

サービスのために取り外したねじ、部品、配線などが元どおりになっているか、またサービスした個所の周辺を劣化させてしまったところがないかなどを点検し、外部金属端子部と、電源プラグの刃の間の絶縁チェックをおこなうなど、安全性が確保されていることを確認してください。

(絶縁チェックの方法)

電源コンセントから電源プラグを抜き、アンテナやプラグなどを外し、電源スイッチを入れます。500V絶縁抵抗計を用いて、電源プラグのそれぞれの端子と外部露出金属部〔アンテナ端子、ヘッドホン端子、マイク端子、入力端子など〕との間で、絶縁抵抗値が1 MΩ以上であることを確認してください。この値以下のときはセットの点検修理が必要です。

注意 安全上重要な部品について

本機に使用している多くの電気部品、および機構部品は安全上、特別な特性を持っています。この特性はほとんどの場合、外観では判別つきにくく、またもとの部品より高い定格（定格電力、耐圧）を持ったものを使用しても安全性が維持されるとは、限りません。安全上の特性を持った部品は、このサービスマニュアルの配線図、部品表に つぎのように表示していますので必ず指定されている部品番号のものを使用願います。

- (1) 配線図… △ マークで表示しています。
- (2) 部品表… △ マークで表示しています。

指定された部品と異なるものを使用した場合には、感電、火災などの危険を生じる恐れがあります。

DIMENSION

W434 X H171 X D410

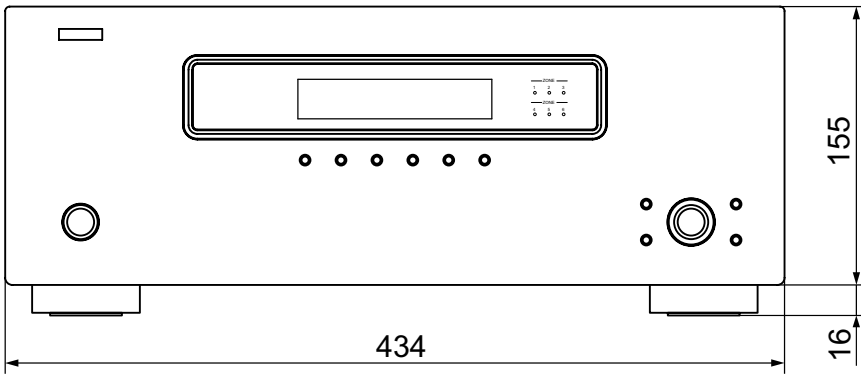
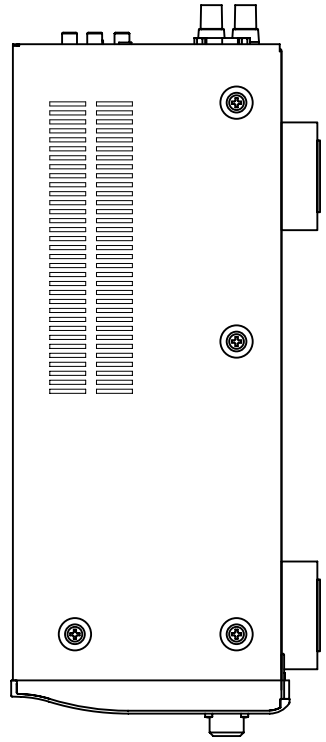
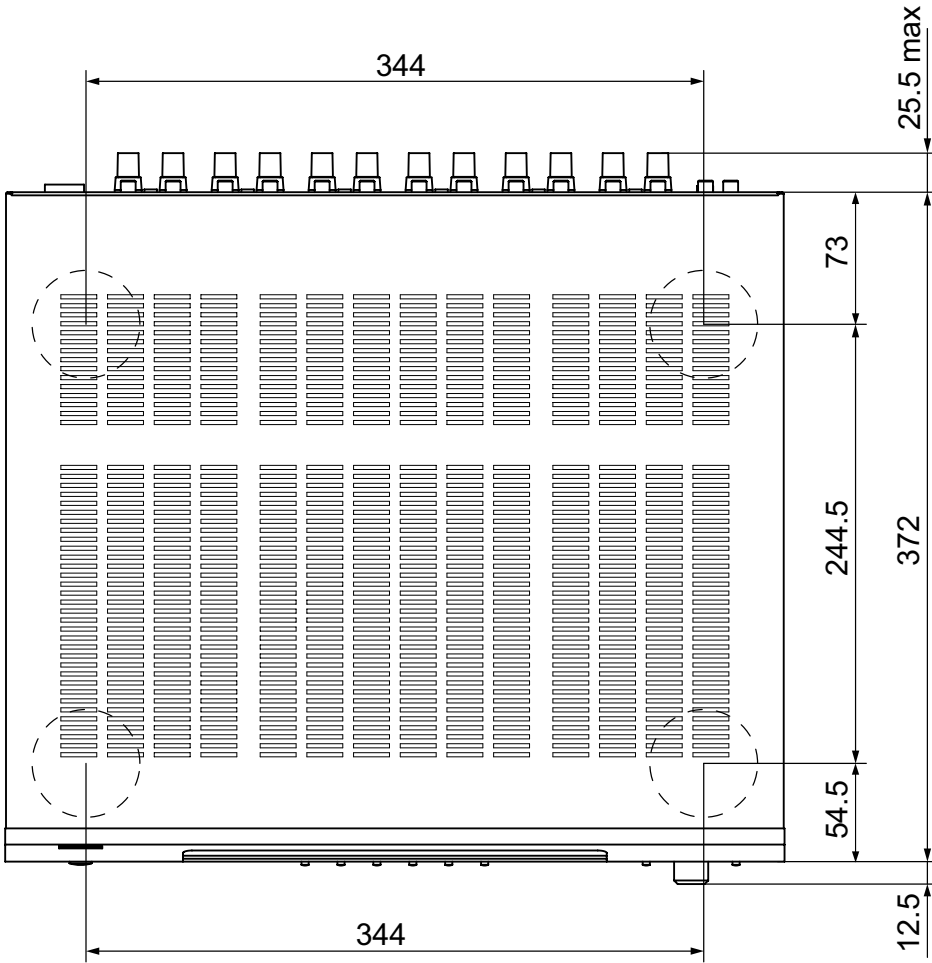
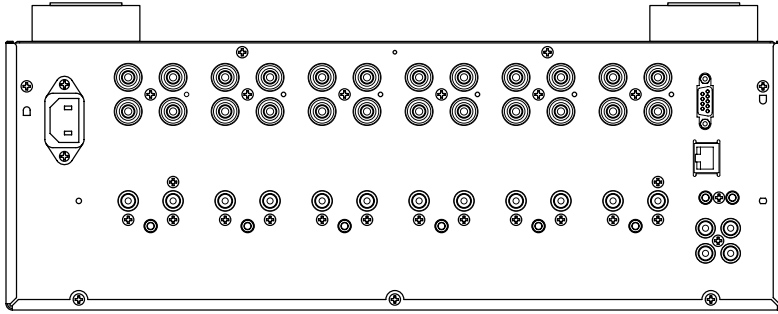

WIRE ARRANGEMENT

If wire bundles are untied or moved to perform adjustment or parts replacement etc., be sure to rearrange them neatly as they were originally bundled or placed afterward. Otherwise, incorrect arrangement can be a cause of noise generation.

ワイヤー整形図

調整や部品の交換等により、ワイヤー類の結束をはずしたり移動させた場合には、それらの作業が完了した時点でワイヤーの整形をおこなってください。正しく整形されていないとノイズ発生の原因となることがあります。

Wire arrangement viewed from the top

上面からみたワイヤー整形

Back Panel side

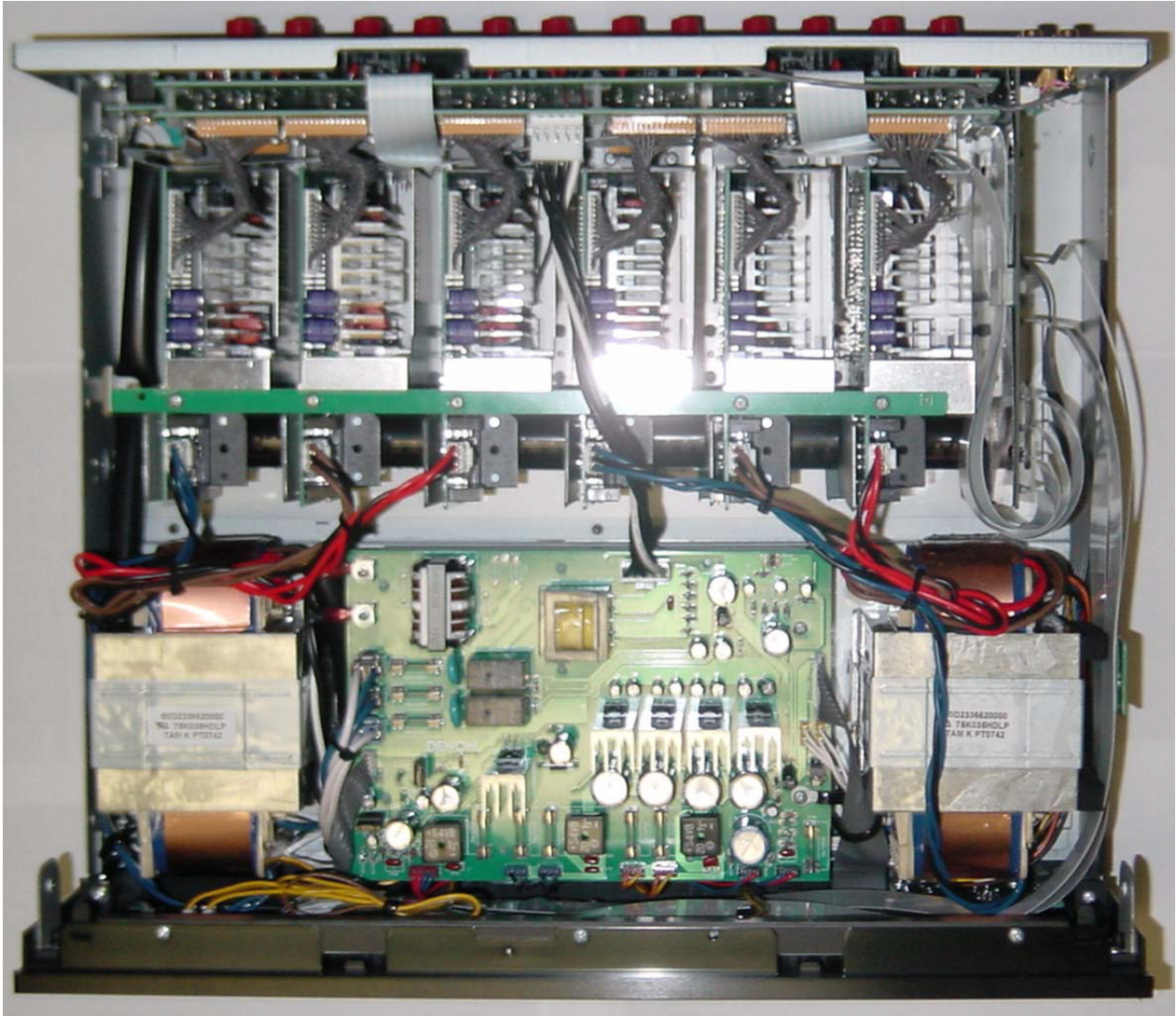

Front Panel side

CAUTION IN SERVICING

Initializing POA-3012CI

S-81/S-81DAB initialization should be performed when the ucom and peripheral parts of ucom are replaced.

1. Unplug the power cord from the power outlet.
2. Connect the power cord to the power outlet while simultaneously pressing the ZONE 5 and DISPLAY buttons.
3. When all Zone operation mode LED are illuminated in red and “* EEPROM INIT. *” is displayed, release finger from two buttons.

Note: • If step 3 does not work, start over from step 1.
• All user settings will be lost and this factory setting will be recovered when this initialization mode. So make sure to memorize your setting for restoring after the initialization.

サービス時の注意事項

本機の初期化について

マイコンやマイコン周辺部品を交換した場合は、本機の初期化をおこなってください。

1. 電源コードをコンセントから抜きます。
2. "ZONE 5" ボタンと "DISPLAY" ボタンを同時に押しながら、電源コードをコンセントへ接続します。
3. Zone の動作表示 LED が全て赤点滅し、“* EEPROM INIT. *” を表示したら、2つのボタンから指を離します。

注意: • 上記3の状態にならない場合は、もう一度操作1からやり直してください。
• 初期化を行うとお客様が設定した内容が工場出荷状態に戻りますので、あらかじめ設定内容を控えておき初期化後再設定してください。

DISASSEMBLY

- Disassemble in order of the arrow of the figure of following flow.
下記フロー図の矢印の順番にはずしてください。
- In the case of the re-assembling, assemble it in order of the reverse of the following flow.
再組み立ての場合は、下記のフローの逆の順番に組立ててください
- In the case of the re-assembling, observe "attention of assembling" it.
再組み立ての場合は、「組立のご注意」を遵守してください。

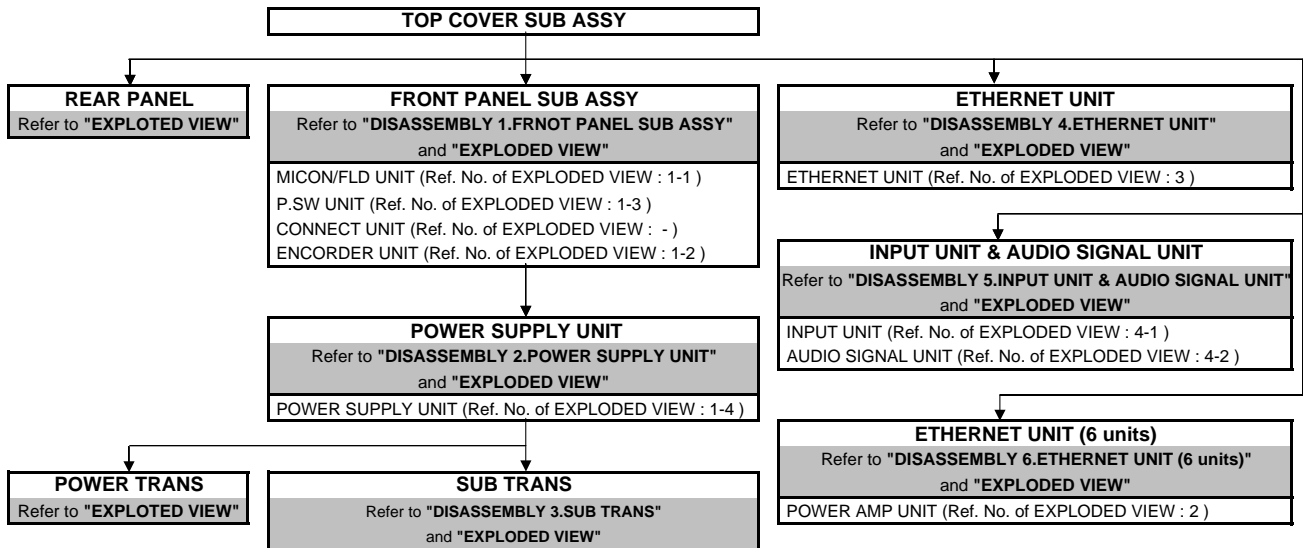

The viewpoint of each photograph
(photography direction)
各図の視点(撮影方向)

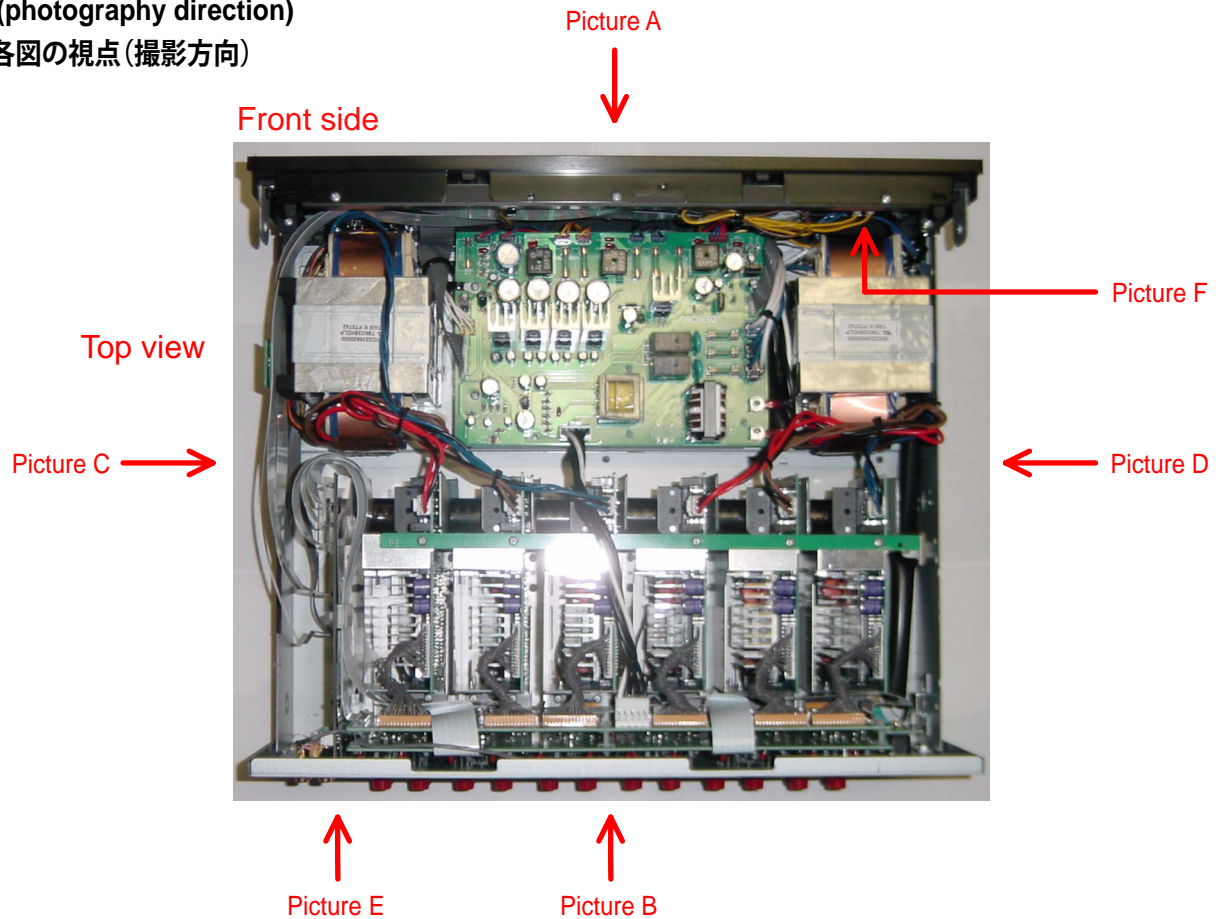

1. FRONT PANEL SUB ASSY

proceeding (手順): **TOP COVER SUB ASSY** → **FRONT PANEL SUB ASSY**

(1) Remove the screws. (ねじをはずす。)

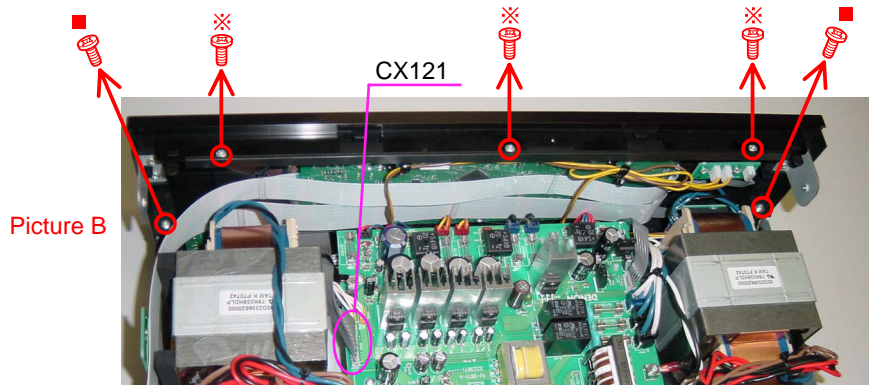
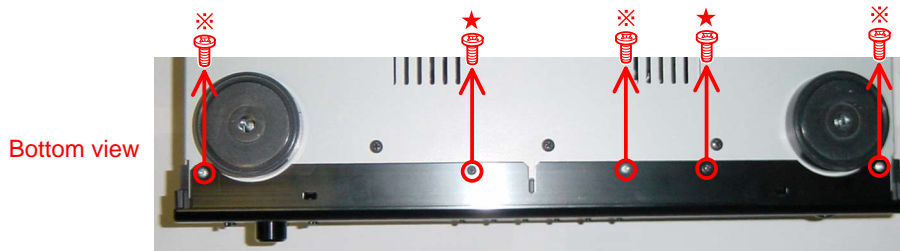

(2) Disconnect the connector wire and FFC Cables. (コネクタワイヤーと FFC ケーブルをはずす。)

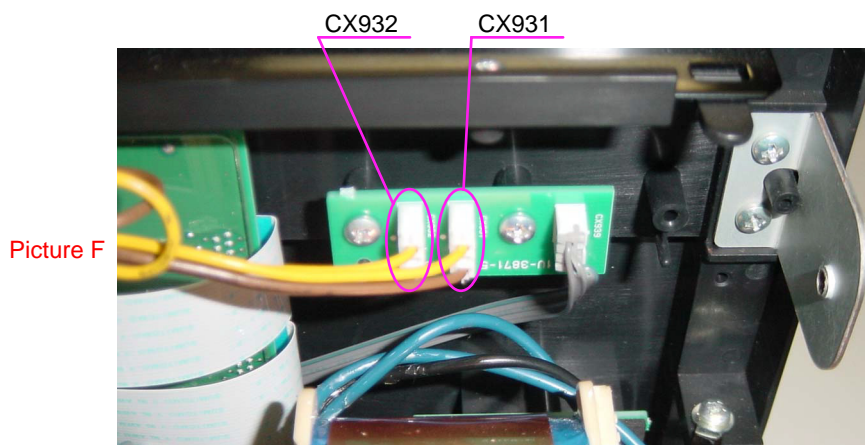
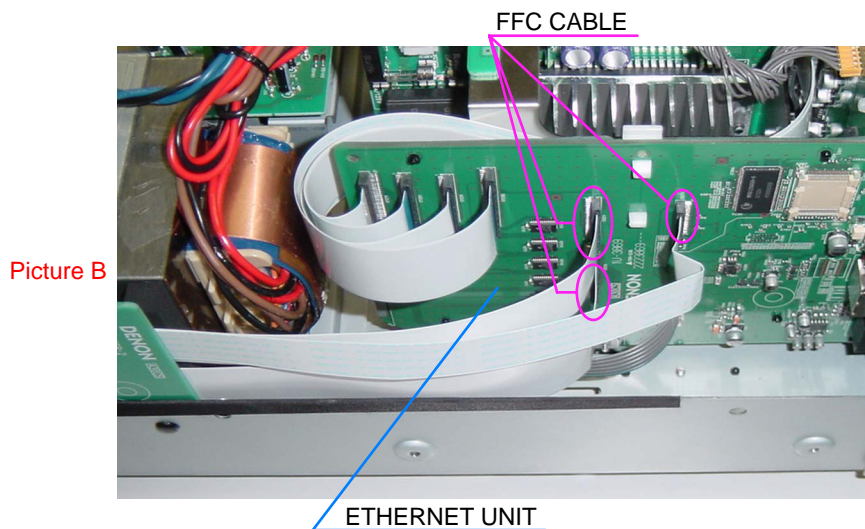

Please refer to "EXPLODED VIEW" for the disassembly method of each P.W.B included in FRNOT PANEL SUB ASSY.
FRONT PANEL SUB ASSY の各基板のはずしかたは "EXPLODED VIEW" を参照してください。

2. POWER SUPPLY UNIT

proceeding (手順) : **TOP COVER SUB ASSY** → **FRONT PANEL SUB ASSY**
 → **POWER SUPPLY UNIT**

(1) Loose the cord holders. (コードホルダーをゆるめる。)

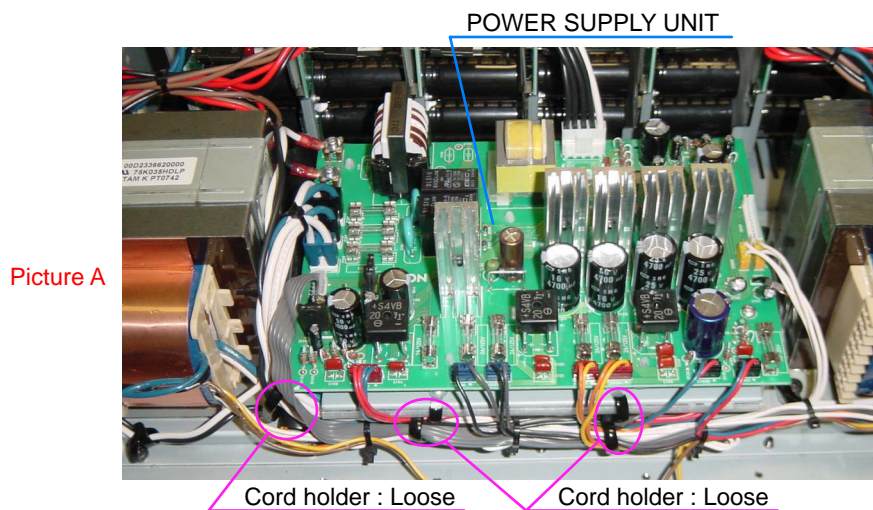

(2) Disconnect the connector wires. (コネクタワイヤーをはずす。)

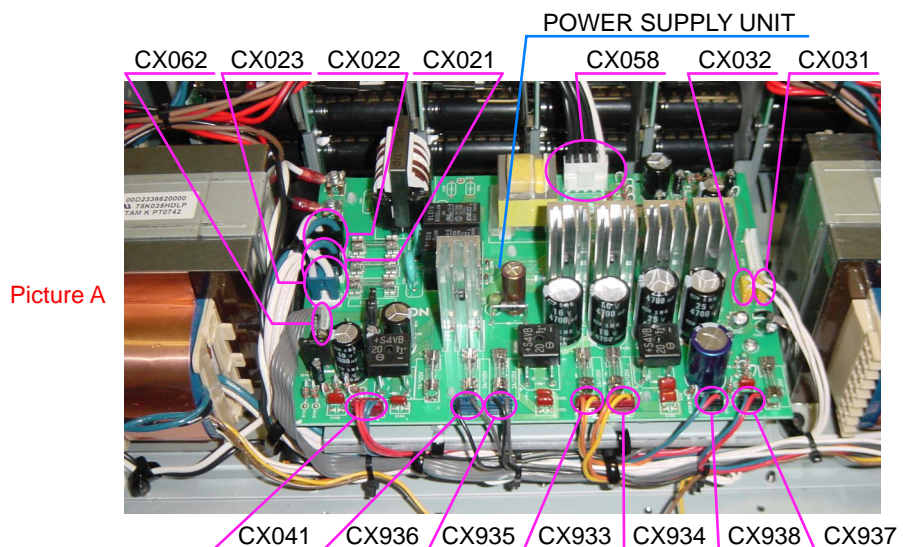

(3) Remove the screws. (ねじをはずす。)

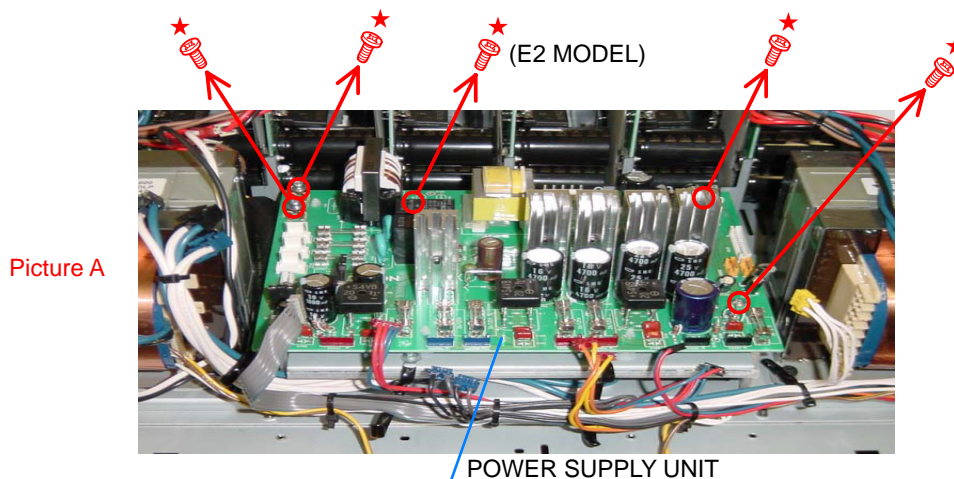

(4) POWER SUPPLY UNIT board off the PCB HOLDER. (PCB HOLDER から POWER SUPPLY UNIT 基板をはずす。)

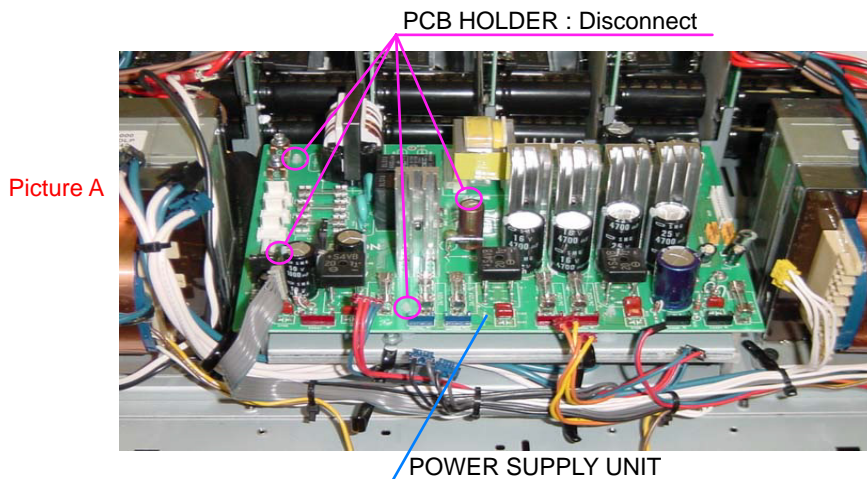

3. SUB TRANS

proceeding (手順) : TOP COVER SUB ASSY → FRONT PANEL SUB ASSY
 → POWER SUPPLY UNIT → SUB TRANS

(1) Remove the screws.(ねじをはずす。)

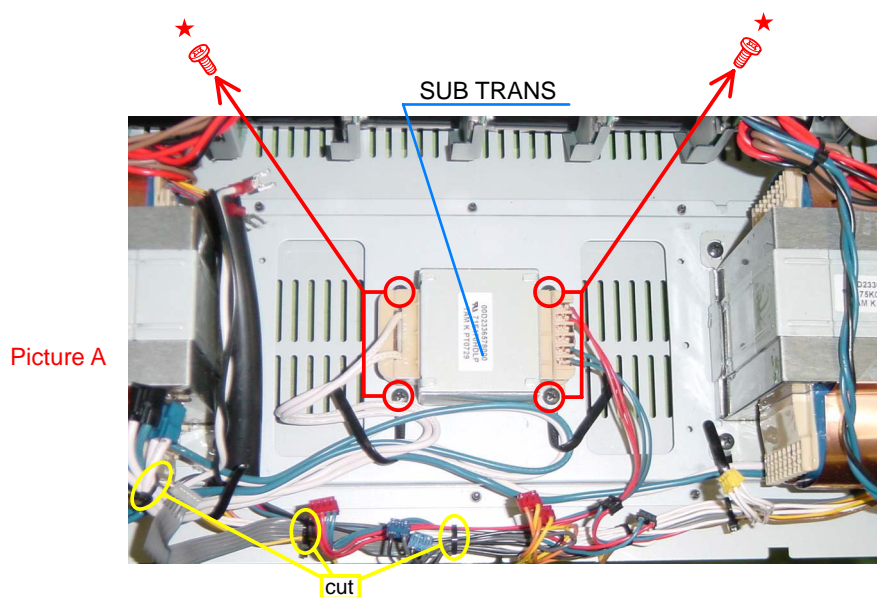
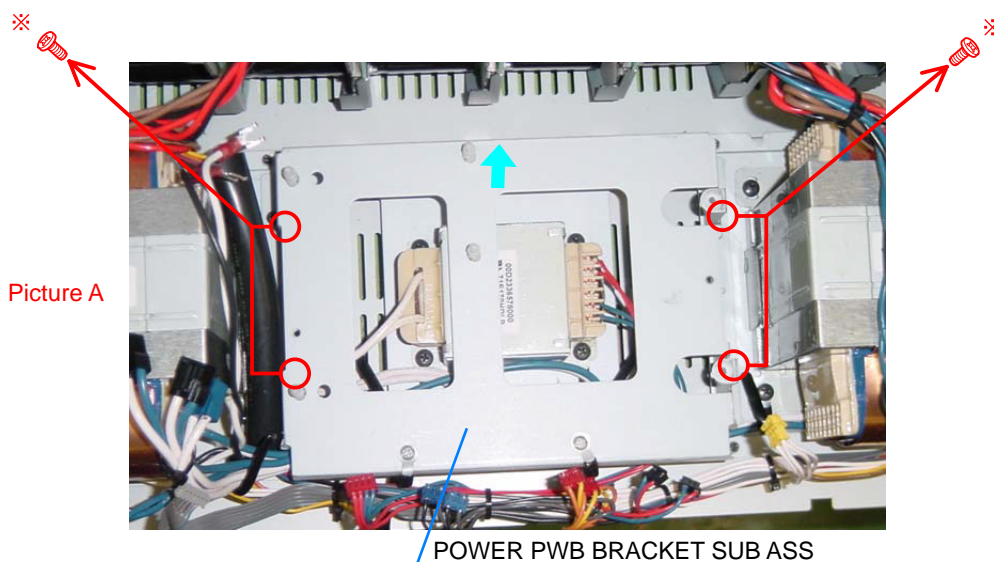

4. ETHERNET UNIT

proceeding (手順): **TOP COVER SUB ASSY** → **ETHERNET UNIT**

(1) Disconnect the connector wires and FFC Cables. (コネクタワイヤーと FFC ケーブルをはずす。)

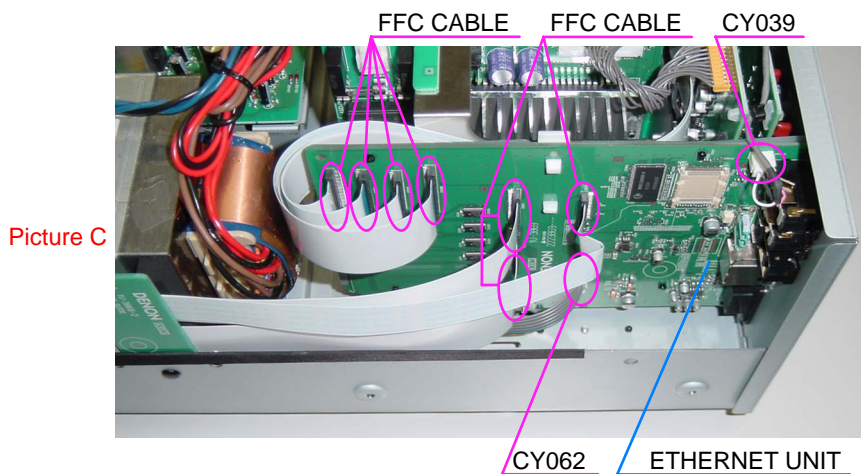

(2) Loose the FFC Holder. (FFCホルダーをゆるめる。)

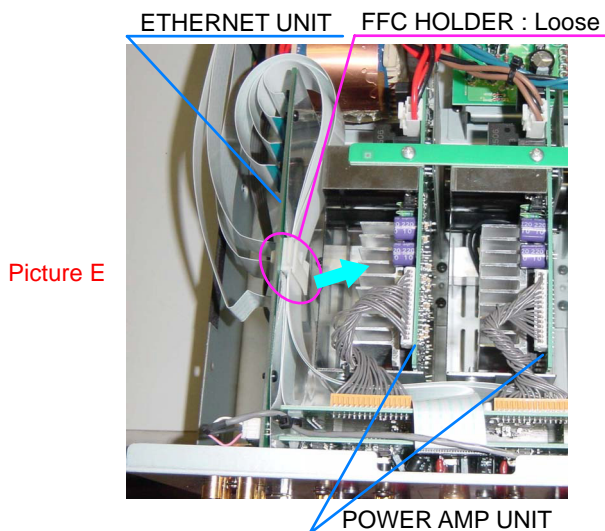

(3) Remove the screws. (ねじをはずす。)

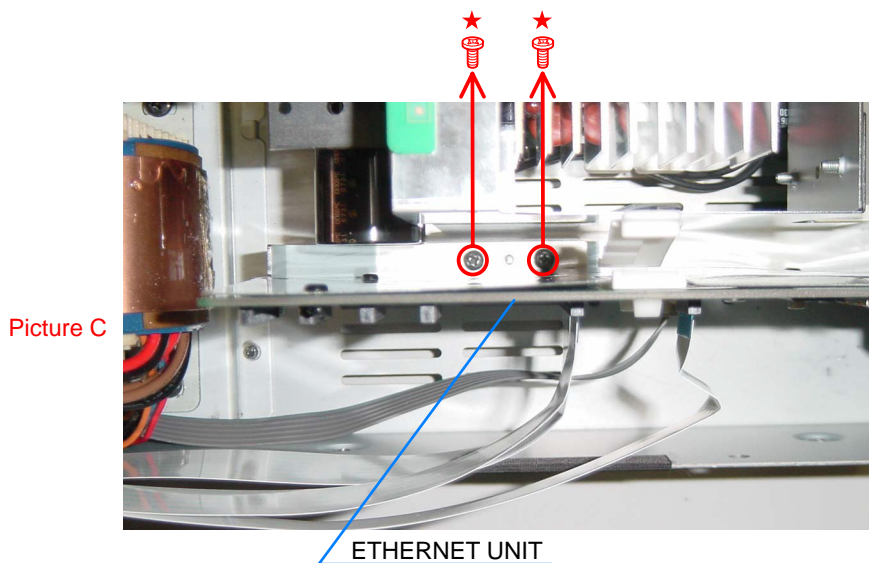



Picture B

(4) Disconnect the EHTHERNET UNIT. (ETHERNET UNIT をはずす。)

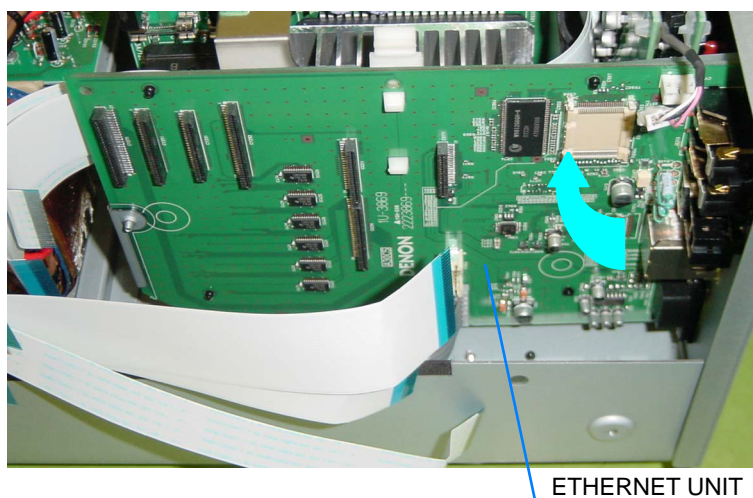

Picture B

ETHERNET UNIT

5. AUDIO SIGNAL UNIT & INPUT UNIT

proceeding (手順) : **TOP COVER SUB ASSY** → **AUDIO SIGNAL UNIT & INPUT UNIT**

(1) Disconnect the connector wire and FFC Cables, and remove the screw. (コネクタワイヤー、FFC ケーブル、ねじをはずす。)

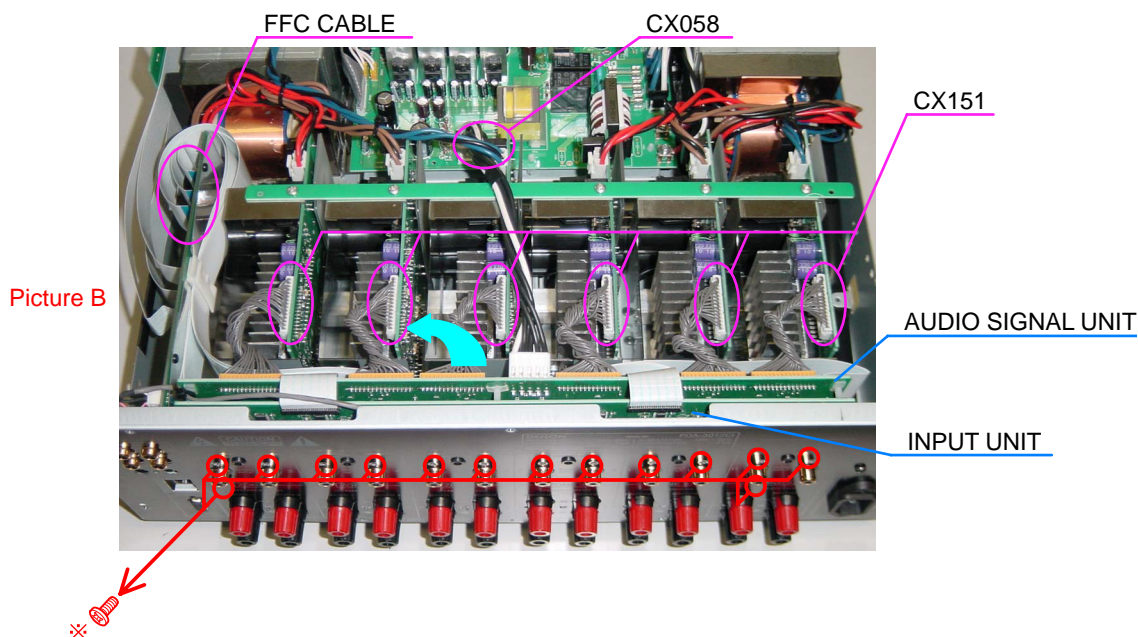

Picture B

(2) AUDIO SIGNAL UNIT board off the INPUT UNIT. (AUDIO UNIT を INPUT UNIT からはずす。)

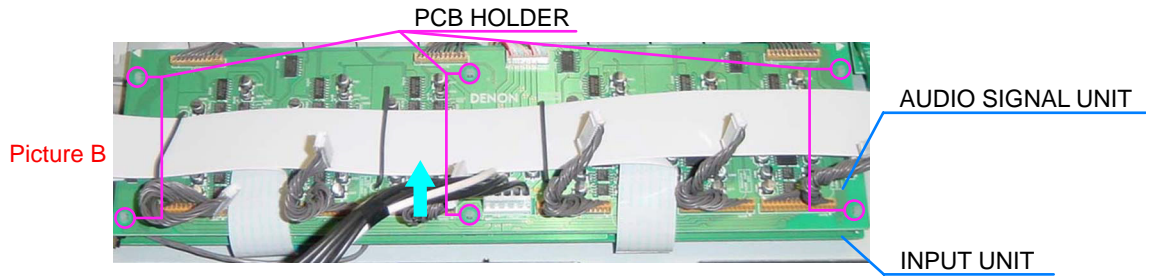

6. POWER AMP UNIT (6 units).

proceeding (手順) : **TOP COVER SUB ASSY** → **POWER AMP UNIT (6 units)**

(1) Remove the screws and disconnect the connector wires. (ねじとコネクタワイヤーをはずす。)

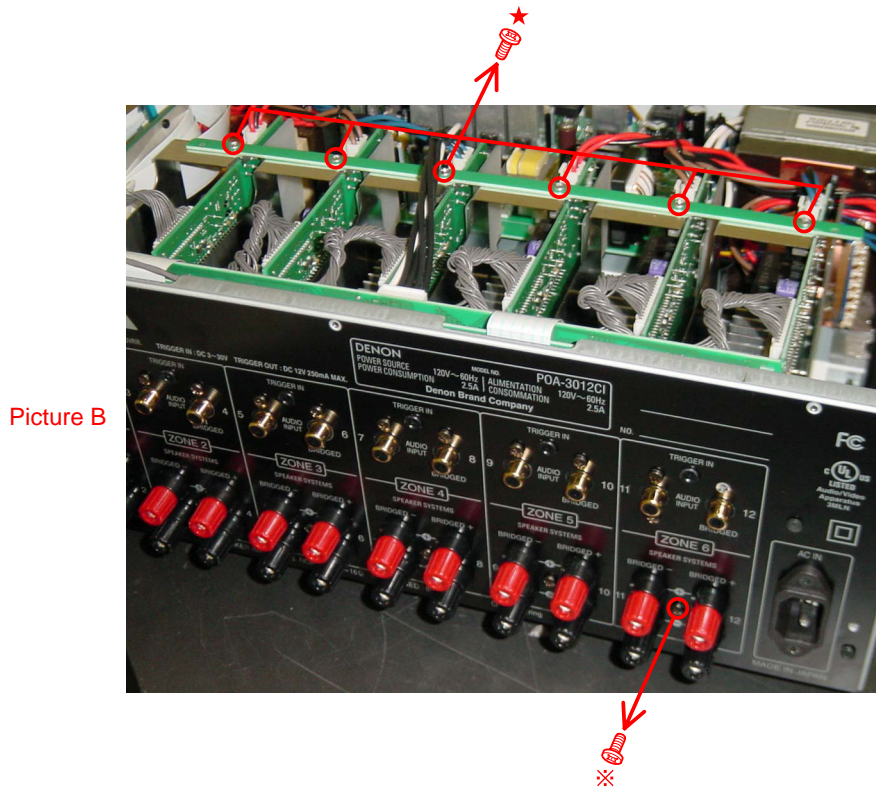

Picture D

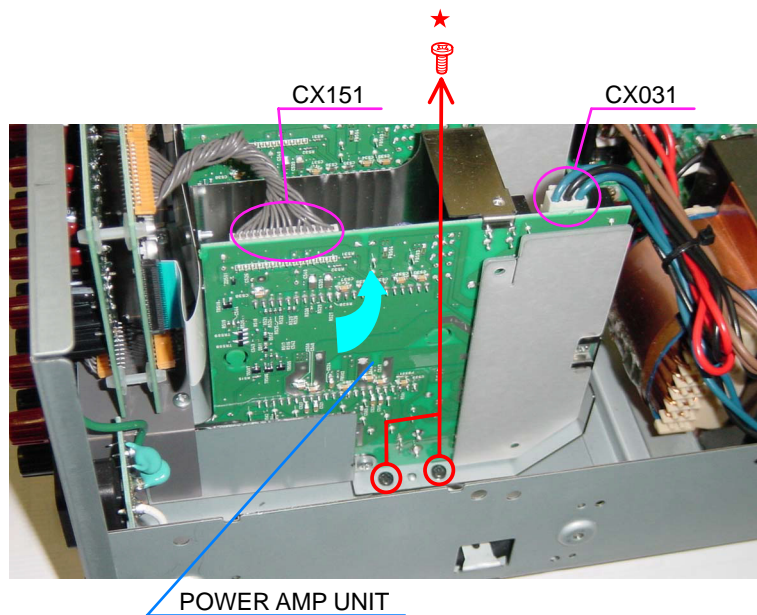

7. REAR PANEL

proceeding (手順): **TOP COVER SUB ASSY** → **REAR PANEL**

Please refer to "**EXPLODED VIEW**" for the disassembly method of REAR PANEL.
REAR PANEL のはずしかたは "**EXPLODED VIEW**" を参照してください。

8. POWER TRANS

proceeding (手順): **TOP COVER SUB ASSY** → **FRONT PANEL SUB ASSY**
→ **POWER TRANS**

Please refer to "**EXPLODED VIEW**" for the disassembly method of POWER TRANS.
POWER TRANS のはずしかたは "**EXPLODED VIEW**" を参照してください。

SPECIAL MODE

No.	Function	Display	ZONE LED
1	Version display		
	<ul style="list-style-type: none"> Connect the power cord to the power outlet while simultaneously pressing the ZONE 6 and MENU buttons. The item number is displayed replay from ① to ⑦ each time the DISPLAY button is pressed. 		
	① Serial No	S e r i a l N o . n n n n n n n n n n	Don't Care
	② Main Version	V e r . : 0 0 . 3 4	
	③ DM850 Version	* E t h e r n e t I M G 1 2 0 0 8 0 3 2 7 0 8 1 2	
	④ DM850 Version	* E t h e r n e t B L B 2 0 0 7 0 7 0 2 0 7 3 3	
	⑤ DM850 Version	* E t h e r n e t C N E C 2 0 0 8 0 3 1 8	
	⑥ DM850 Version	* E t h e r n e t W E B W 2 0 0 8 0 3 2 7 0 8 0 1	
	⑦ Mac Address	* E t h e r n e t M A C n n n n n n - n n n n n n	
2	Compulsorily ROM rewriting mode		
	When failing in rewriting to Main Microprocessor ROM, it's rewritten in DENON WRITER compulsorily.		
	<ul style="list-style-type: none"> Connect the power cord to the power outlet while simultaneously pressing the ZONE 5 and Δ buttons. 	Off	Green ●●●●
3	Initialization mode (Excluding Installer setup)		
	* Backup data excluding the data for Installer setup is initialized.		
	<ul style="list-style-type: none"> Connect the power cord to the power outlet while simultaneously pressing the ZONE 5 and DISPLAY buttons. When the button is released, it returns to Normal Mode. 	* E E P R O M I N I T . * n n n n n n n n n n	Red ●●●●
4	Service initialization mode		
	* All data is initialized.		
	<ul style="list-style-type: none"> Connect the power cord to the power outlet while simultaneously pressing the ZONE 3 and DISPLAY buttons. 	* E E P R O M I N I T . * n n n n n n n n n n	Red ●●●●

特殊モード

No.	動作	FL 表示管	ZONE LED
1	バージョン表示		
	<ul style="list-style-type: none"> 本体 ZONE 6 ボタンと MENU ボタンを同時に押しながら AC コードを接続する。 DISPLAY ボタンを押すごとに ① から ⑦ の表示を繰り返す。 		
	① Serial No	S e r i a l N o . n n n n n n n n n n	Don't Care
	② Main Version	V e r . : 0 0 . 3 4	
	③ DM850 の Version	* E t h e r n e t I M G 1 2 0 0 8 0 3 2 7 0 8 1 2	
	④ DM850 の Version	* E t h e r n e t B L B 2 0 0 7 0 7 0 2 0 7 3 3	
	⑤ DM850 の Version	* E t h e r n e t C N E C 2 0 0 8 0 3 1 8	
	⑥ DM850 の Version	* E t h e r n e t W E B W 2 0 0 8 0 3 2 7 0 8 0 1	
	⑦ Mac Address	* E t h e r n e t M A C n n n n n n - n n n n n n	
2	強制 ROM 書き換えモード		
	* Main マイコンの ROM への書き換えが途中で失敗した場合に、強制的に DENON WRITER で書き換えをおこなう。		
	<ul style="list-style-type: none"> 本体 ZONE 5 ボタンと Δ ボタンを同時に押しながら AC コードを接続する。 	Off	Green ●●●●
3	初期化モード (Installer setup 除く)		
	* Installer setup 用のデータを除いたバックアップデータの初期化をおこなう。		
	<ul style="list-style-type: none"> 本体 ZONE 5 ボタンと DISPLAY ボタンを同時に押しながら AC コードを接続する。 ボタンを離すと、Normal Mode に戻る。 	* E E P R O M I N I T . * n n n n n n n n n n	Red ●●●●
4	サービス初期化モード		
	* 全てのデータの初期化をおこなう。		
	<ul style="list-style-type: none"> 本体 ZONE 3 ボタンと DISPLAY ボタンを同時に押しながら AC コードを接続する。 	* E E P R O M I N I T . * n n n n n n n n n n	Red ●●●●

No.	Function	Display	ZONE LED
5	Installer initialization mode		
	* Only the data for Installer setup is initialized		
	• Connect the power cord to the power outlet while simultaneously pressing the ZONE 3 and SETUP buttons.		Don't Care
6	Installer mode		
	* Installer Setup is executed. The item of Installer Setup is displayed on the Web screen.		
	• Connect the power cord to the power outlet while simultaneously pressing the ZONE 4 and SETUP buttons.		Don't Care
7	Recovery update mode		
	When failing in rewriting to Main Microprocessor ROM, it's rewritten in DPMS compulsorily.		
	• Connect the power cord to the power outlet while simultaneously pressing the ZONE 6 and Δ buttons.		Don't Care

No.	動作	FL 表示管	ZONE LED
5	インストーラー初期化モード		
	* インストーラー用のデータのみの初期化をおこなう。		
	• 本体 ZONE 3 ボタンと SETUP ボタンを同時に押しながら AC コードを接続する。		Don't Care
6	インストーラーモード		
	* インストーラーをおこなう。Web 画面上に Installer Setup の項目を表示する。		
	• 本体 ZONE 4 ボタンと SETUP ボタンを同時に押しながら AC コードを接続する。		Don't Care
7	リカバーアップデートモード		
	* Main マイコンの ROM への書き換えが途中で失敗した場合に、強制的に DPMS で書き換えをおこなう。		
	• 本体 ZONE 6 ボタンと Δ ボタンを同時に押しながら AC コードを接続する。		Don't Care

TROUBLE SHOOTING

トラブルシューティング

FLOW CHART NO.1

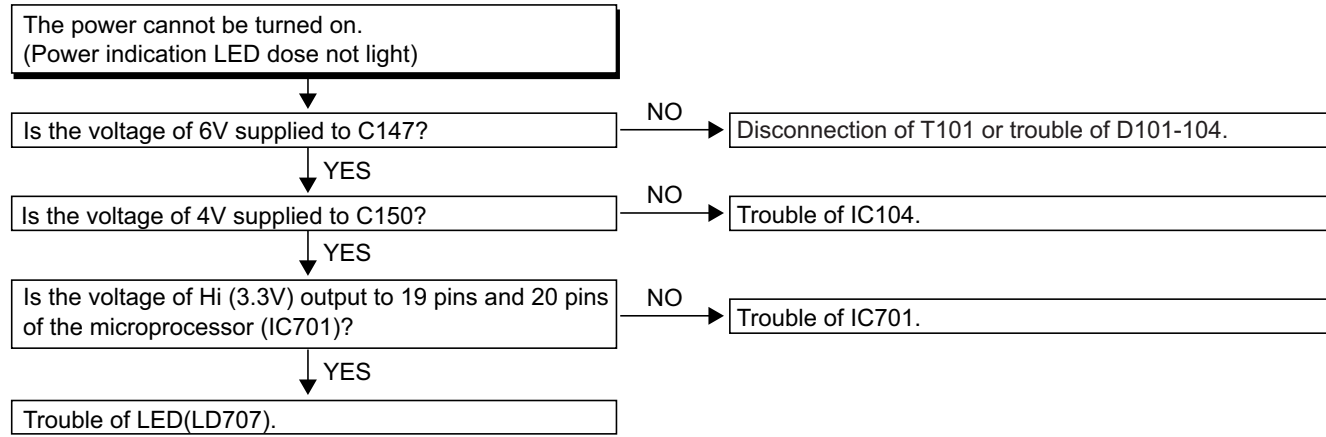

FLOW CHART NO.2

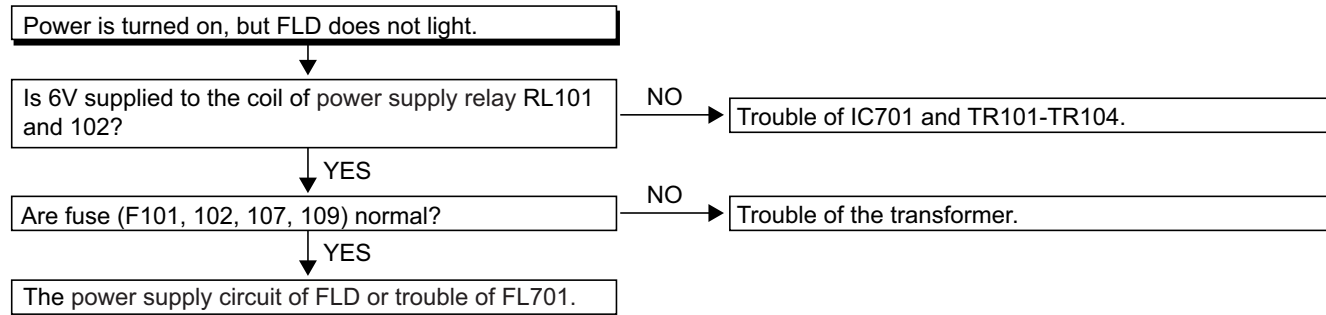

FLOW CHART NO.3

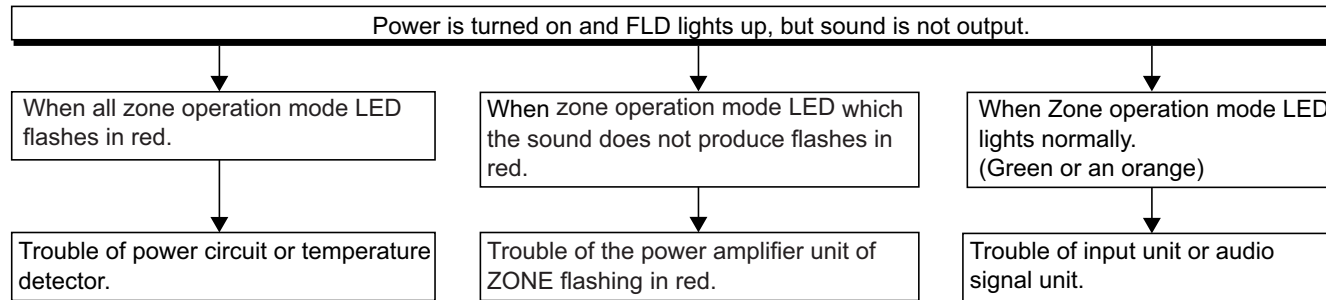

FLOW CHART NO.4

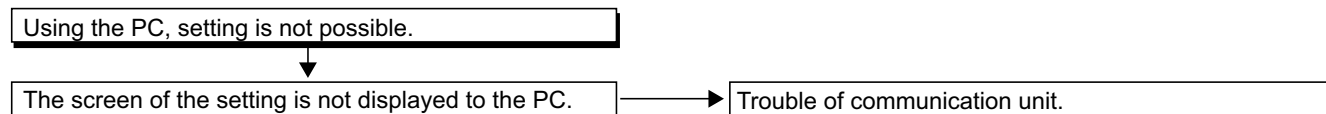

フローチャート NO.1

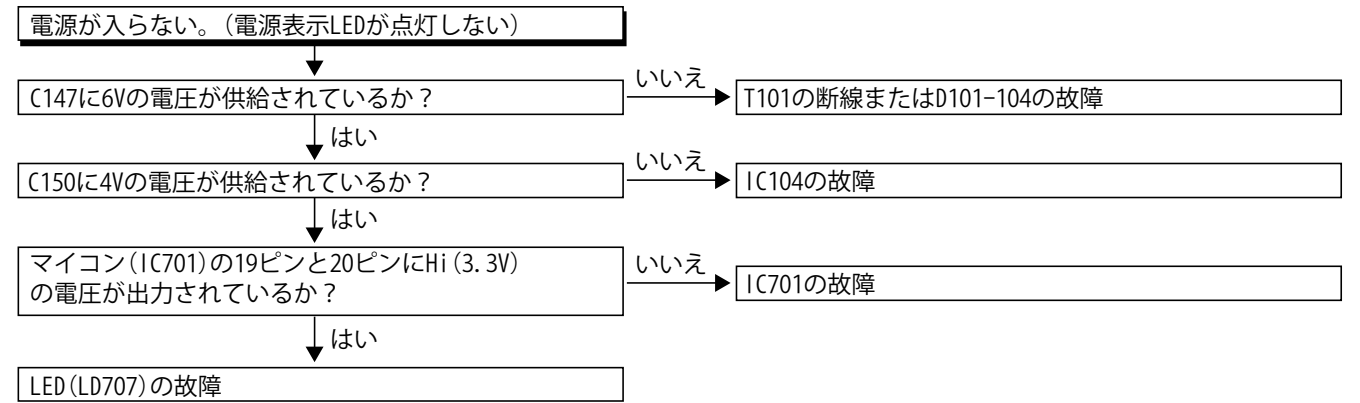

フローチャート NO.2

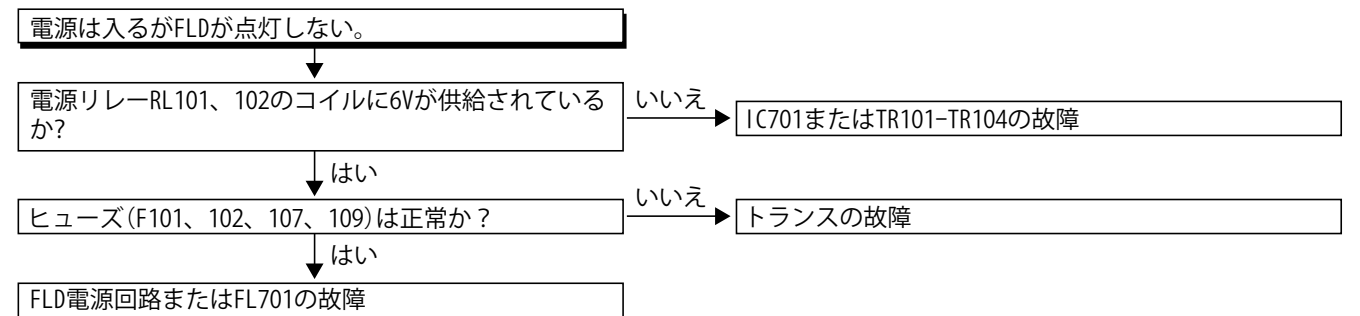

フローチャート NO.3

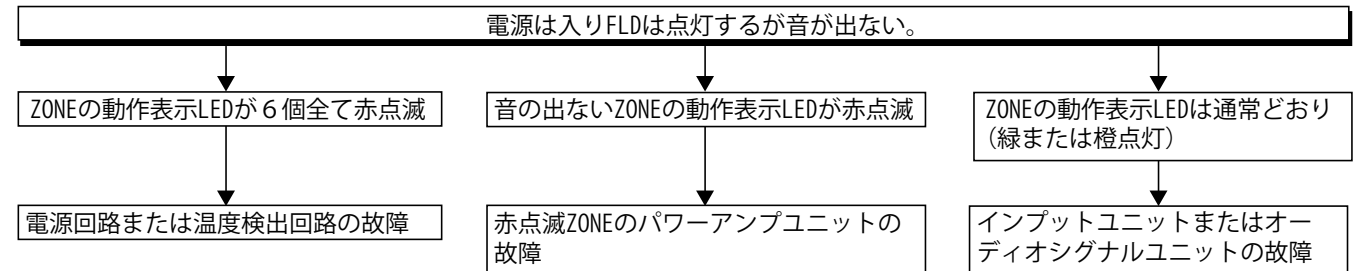

フローチャート NO.4

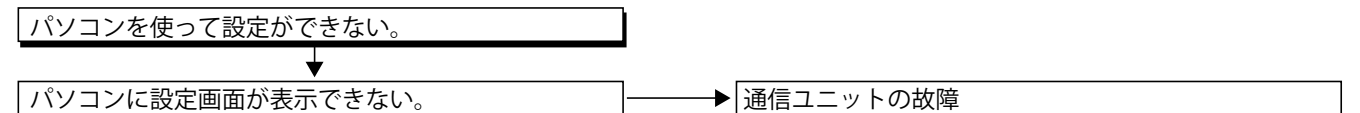

BLOCK/LEVEL DIAGRAM

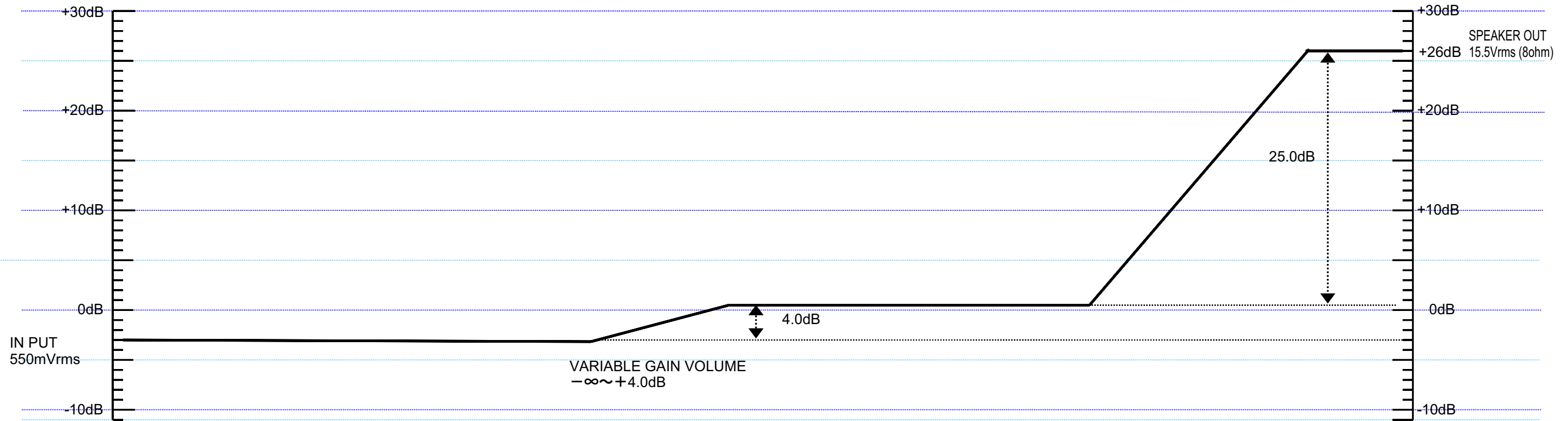
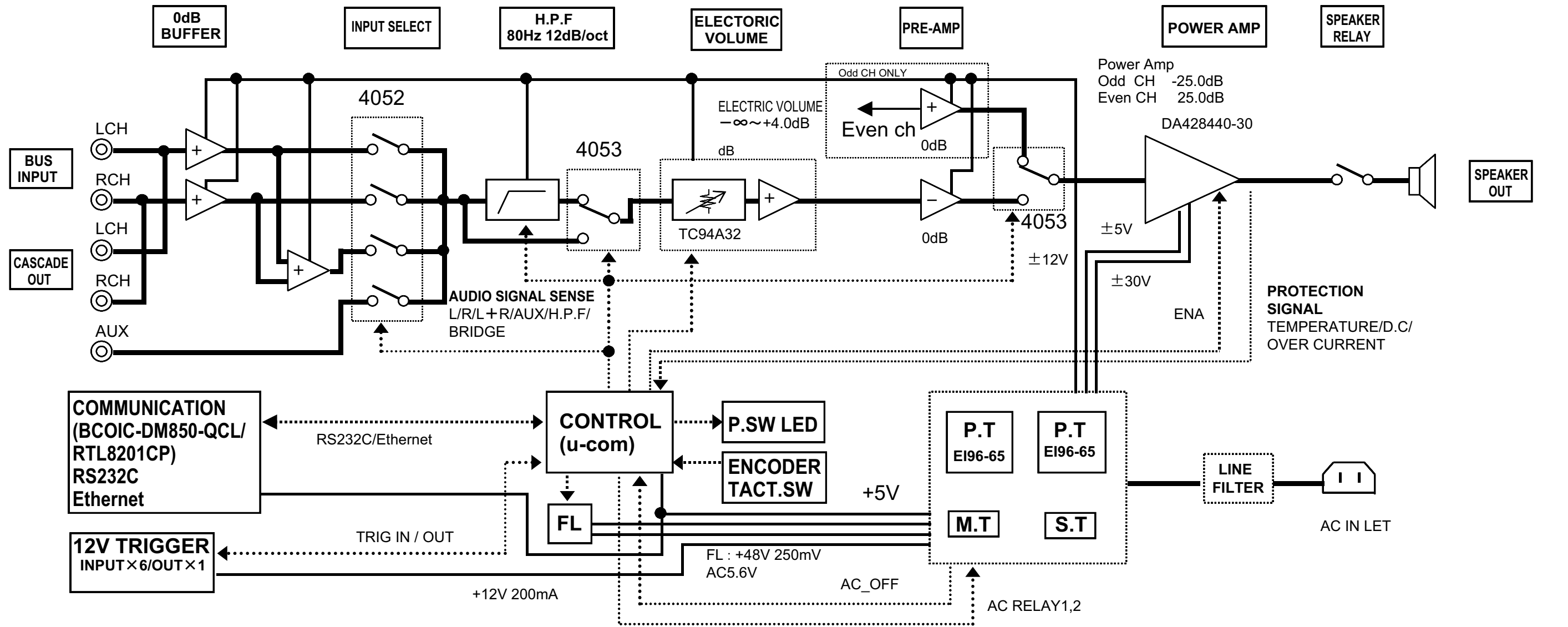

SEMICONDUCTORS

Only major semiconductors are shown, general semiconductors etc. are omitted to list.
 主な半導体を記載しています。汎用の半導体は記載を省略しています。

1. IC's

BCOIC-DM850-CQL (IC905)

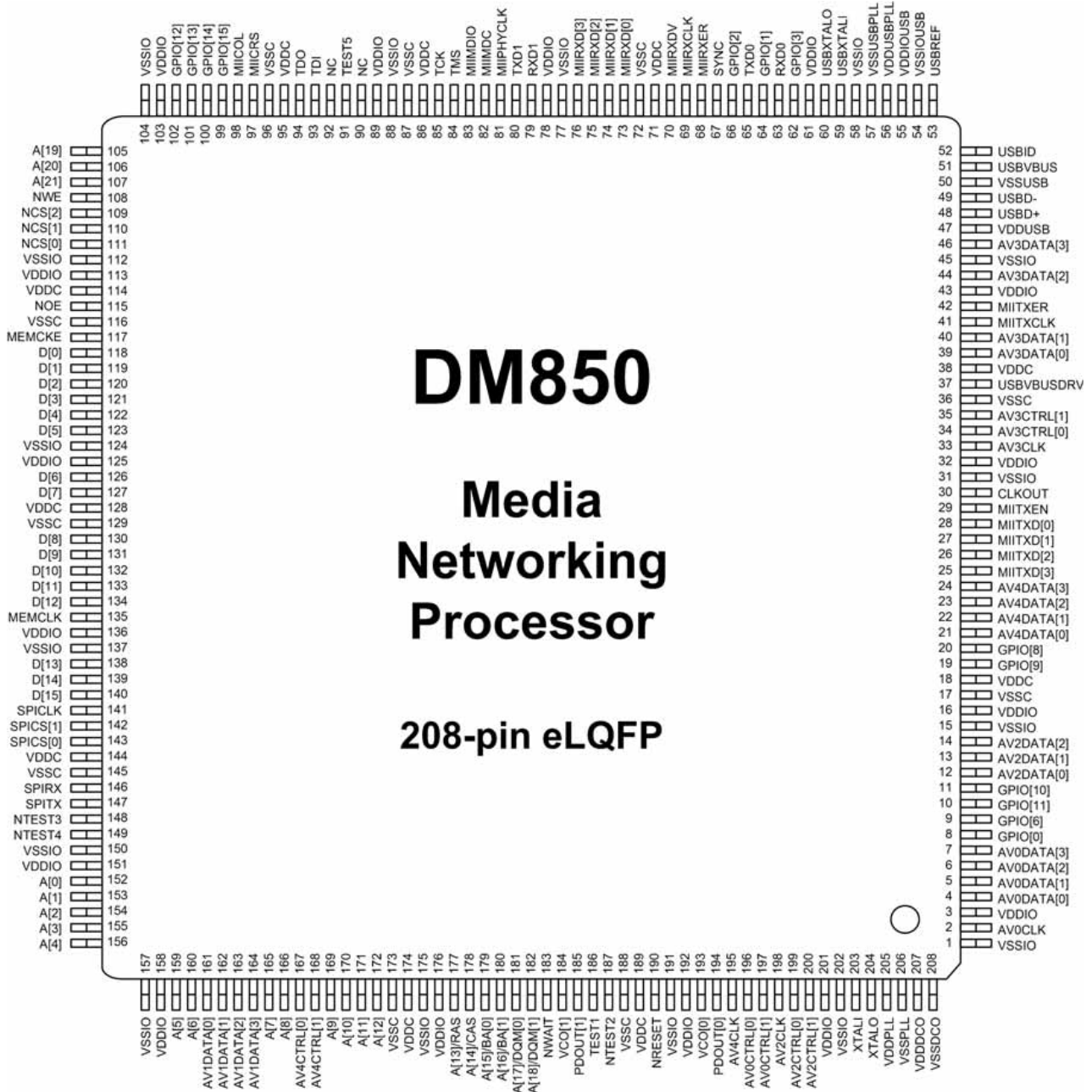

BCOIC-DM850-CQL Functional Diagram

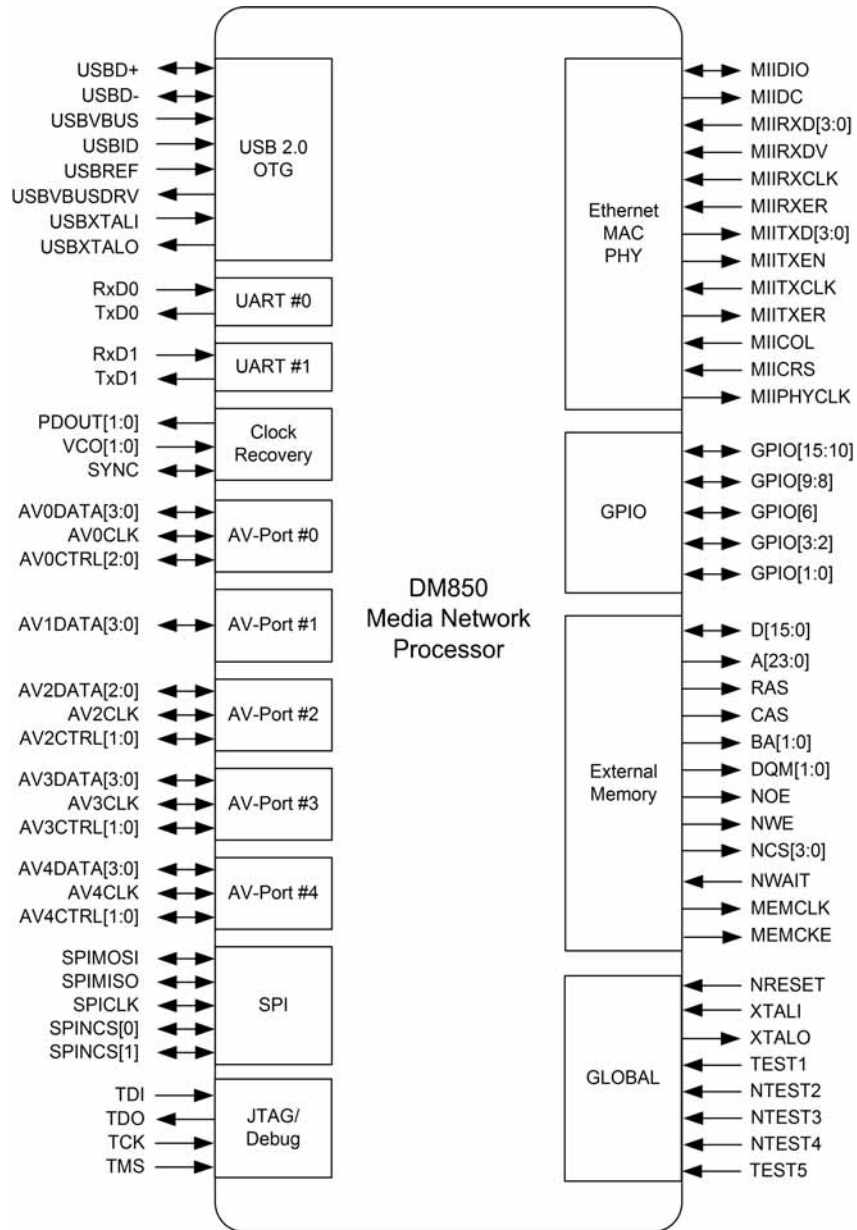

M3062LFGPGP (IC701)

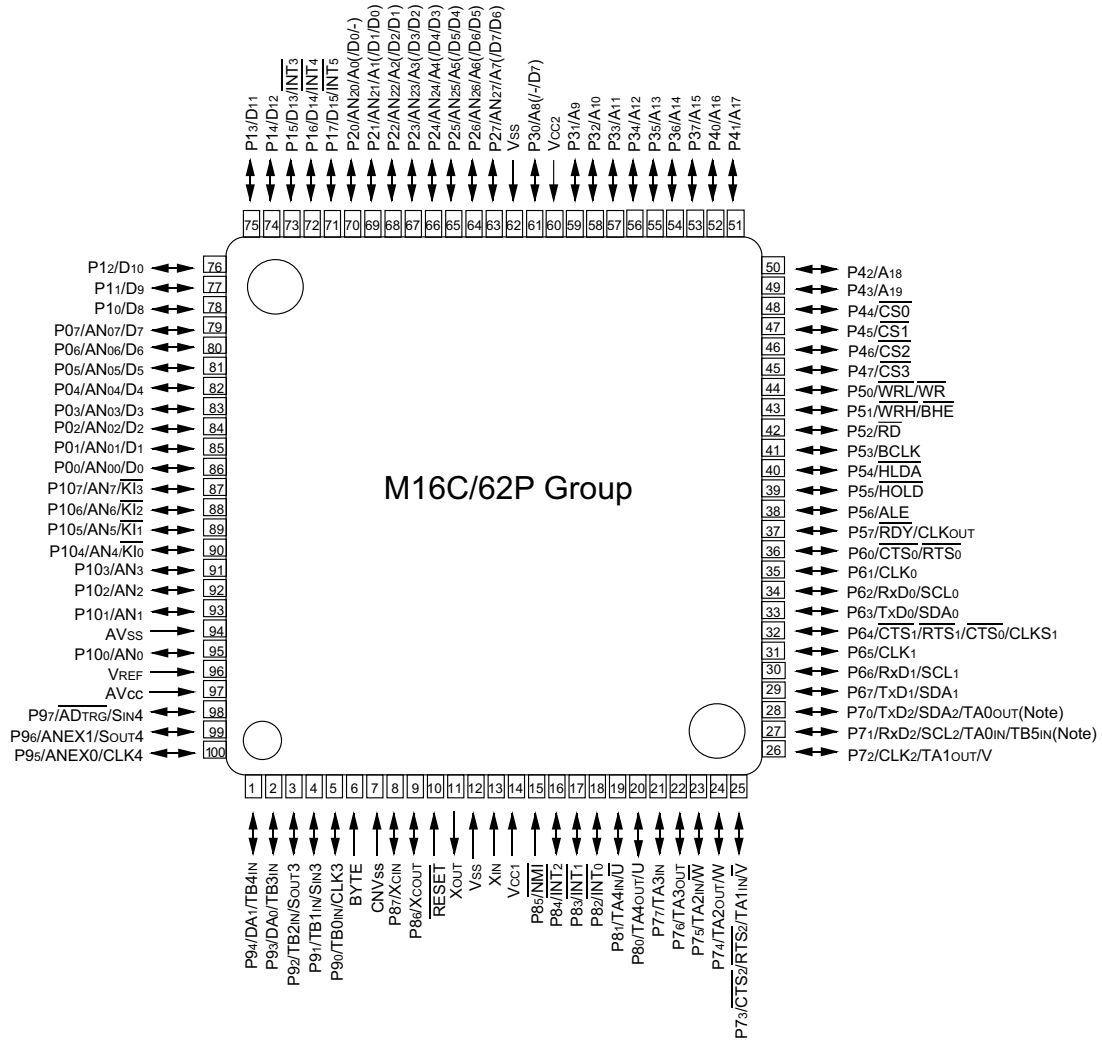

BLOCK DIAGRAM

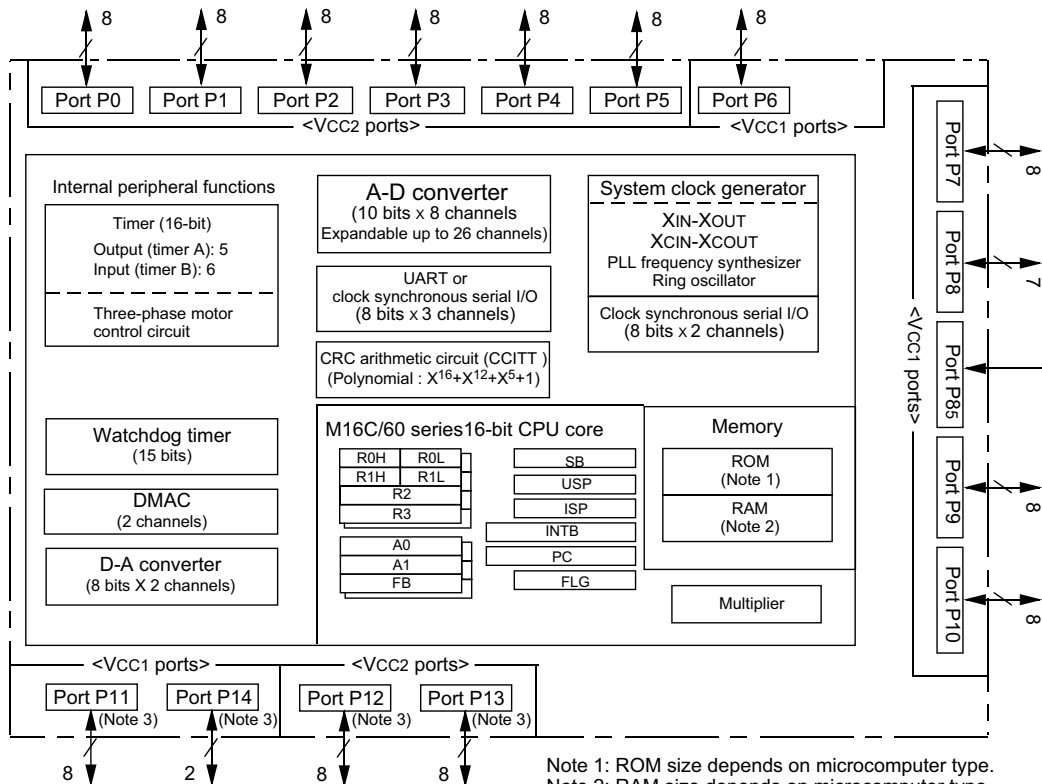

Note 1: ROM size depends on microcomputer type.
Note 2: RAM size depends on microcomputer type.
Note 3: Ports P11 to P14 exist only in 128-pin version.

Terminl Function

PIN No.	PIN Name	Port Name	Function	I/O	Remarks
1	P9_4/DA1/TB4IN	LED_G6		O	
2	P9_3/DA0/TB3IN	FL_RESET		O	
3	P9_2/TB2IN/SOUT3	LED_G5		O	
4	P9_1/TB1IN/SIN3	LED_G4		O	
5	P9_0/TB0IN/CLK3	LED_G3		O	
6	BYTE	VSS	VSS	I	
7	CNVSS	CNVSS		I	
8	P8_7/XCIN	LED_G2		O	
9	P8_6/XCOUT	LED_G1		O	
10	RESET	RESET	RESET	I	
11	XOUT	XTAL	MAIN OSC	O	
12	VSS	VSS	VSS	I	
13	XIN	XTAL	MAIN OSC	I	
14	VCC1	VCC	VCC	I	
15	P8_5/NMI	PULL UP		I	
16	P8_4/INT2/ZP	ETH REQ	ETHERNETNET	I	
17	P8_3/INT1	M_TRIG	MASTER TRIGGER IN	I	signal : "L"
18	P8_2/INT0	P.SW	TACT KEY	I	
19	P8_1/TA4IN/U	P.LED_G		O	
20	P8_0/TA4OUT/U	P.LED_R		O	
21	P7_7/TA3IN	ENC_B	ENCODER	I	
22	P7_6/TA3OUT	ENC_A	ENCODER	I	
23	P7_5/TA2IN/W	FLCS	FLD CHIP SERECT	O	
24	P7_4/TA2OUT/W	THERMAL		I	Error : "H"
25	P7_3/CSTS2/RTS2/TA1IN/V	ETH SPIMOEI	ETHERNET	O	
26	P7_2/CLK2/TA1OUT/V	ETH SPICLK	ETHERNET	O	
27	P7_1/RXD2/SCL2/TA0IN/TB5IN	ETH RXDMOEI	ETHERNET	I	
28	P7_0/TXD2/SDA2/TA0OUT	ETH TXDMIEO	ETHERNET	O	OPEN DRAIN
29	P6_7/TXD1/SDA1	RS232C_TX	RS232C	O	
30	P6_6/RXD1/SCL1	RS232C_RX	RS232C	I	
31	P6_5/CLK1	ETH SPIMIEO	ETHERNET	O	
32	P6_4/CTS1/RTS1/CTS0/CLKS1	ETH RESET	ETHERNET	O	
33	P6_3/TXD0/SDA0	TEST	TEST	I	
34	P6_2/RXD0/SCL0	TEST	TEST	I	check mode : "L"
35	P6_1/CLK0	ETH MODE	ETHERNET	O	
36	P6_0/CTS0/RTS0	ETH SPICS	ETHERNET	O	
37	P5_7/RDY/CLKOUT	LED_R6		O	
38	P5_6/ALE	LED_R5		O	
39	P5_5/HOLD	EPM		O	
40	P5_4/HLDĀ	E2P_CLK		O	
41	P5_3/BCLK	E2P_DO		O	
42	P5_2/RĀ	E2P_DI		I	
43	P5_1/WRH/BHE	E2P_CS		O	
44	P5_0/WRL/WR	CE	WRIGHT/READ	I	
45	P4_7/CS3	LED_R4		O	
46	P4_6/CS2	LED_R3		O	
47	P4_5/CS1	LED_R2		O	
48	P4_4/CS0	LED_R1		O	
49	P4_3/A19	CH12	Channel switching	O	
50	P4_2/A18	CH11	Channel switching	O	
51	P4_1/A17	CH10	Channel switching	O	
52	P4_0/A16	CH9	Channel switching	O	
53	P3_7/A15	CH8	Channel switching	O	
54	P3_6/A14	CH7	Channel switching	O	
55	P3_5/A13	CH6	Channel switching	O	
56	P3_4/A12	CH5	Channel switching	O	
57	P3_3/A11	CH4	Channel switching	O	
58	P3_2/A10	CH3	Channel switching	O	
59	P3_1/A9	CH2	Channel switching	O	
60	VCC2	VCC2	VCC	I	

PIN No.	PIN Name	Port Name	Function	I/O	Remarks
61	P3_0/A8(D7)	CH1	Channel switching	O	
62	VSS	VSS2	VSS	I	
63	P2_7/ANA2_7(D7/D6)	T.THERMO	T.THERMO SW	I	Error : "H"
64	P2_6/ANA2_6(D6/D5)	TEMP	Temperature detect	I	Error : "H"
65	P2_5/ANA2_5(D5/D4)	INPUT_B		O	
66	P2_4/ANA2_4(D4/D3)	INPUT_A		O	
67	P2_3/ANA2_3(D3/D2)	BTL		O	
68	P2_2/ANA2_2(D2/D1)	H.P.F		O	
69	P2_1/ANA2_1(D1/D0)	SIGNAL SENS		I	signal : "L"
70	P2_0/ANA2_0(D0/-)	ENA		O	
71	P1_7/D15/INT5	TRG.DET	Trigger output error	I	Error : "H"
72	P1_6/D14/INT4	AC_OFF	AC Y/N	I	Error : "L"
73	P1_5/D13/INT3	PROTECT_6		I	Error : "L"
74	P1_4/D12	PROTECT_5		I	Error : "L"
75	P1_3/D11	PROTECT_4		I	Error : "L"
76	P1_2/D10	PROTECT_3		I	Error : "L"
77	P1_1/D9	PROTECT_2		I	Error : "L"
78	P1_0/D8	PROTECT_1		I	Error : "L"
79	P0_7/AN0_7/D7	P.ON/OFF2	AC RELAY2	O	
80	P0_6/AN0_6/D6	P.ON/OFF1	AC RELAY1	O	
81	P0_5/AN0_5/D5	VOL_DATA2	TC94A32FG	O	
82	P0_4/AN0_4/D4	VOL_CLOCK2	TC94A32FG	O	
83	P0_3/AN0_3/D3	VOL_STROBE2	TC94A62FG	O	
84	P0_2/AN0_2/D2	VOL_DATA1	TC94A32FG	O	
85	P0_1/AN0_1/D1	VOL_CLOCK1	TC94A32FG	O	
86	P0_0/AN0_0/D0	VOL_STROBE1	TC94A62FG	O	
87	P10_7/AN7/KI3	SP6	SP RELAY	O	
88	P10_6/AN6/KI2	SP5	SP RELAY	O	
89	P10_5/AN5/KI1	SP4	SP RELAY	O	
90	P10_4/AN4/KI0	SP3	SP RELAY	O	
91	P10_3/AN3	SP2	SP RELAY	O	
92	P10_2/AN2	SP1	SP RELAY	O	
93	P10_1/AN1	KEY1	ENCODER SW	I	A/D
94	AVSS	VSS	VSS	I	
95	P10_0/AN0	KEY0	TACT KEY	I	A/D
96	VREF	VCC	VCC	I	
97	AVCC	VCC	VCC	I	
98	P9_7/ADTRG/SIN4	TRIG IN	ZONE TRIGGER	I	signal : "L"
99	P9_6/ANEX1/SOUT4	FL_DA	FLD DATA	O	
100	P9_5/ANEX0/CLK4	FL_CLK	FLD CLOCK	O	

DA428440E-E (IC501)

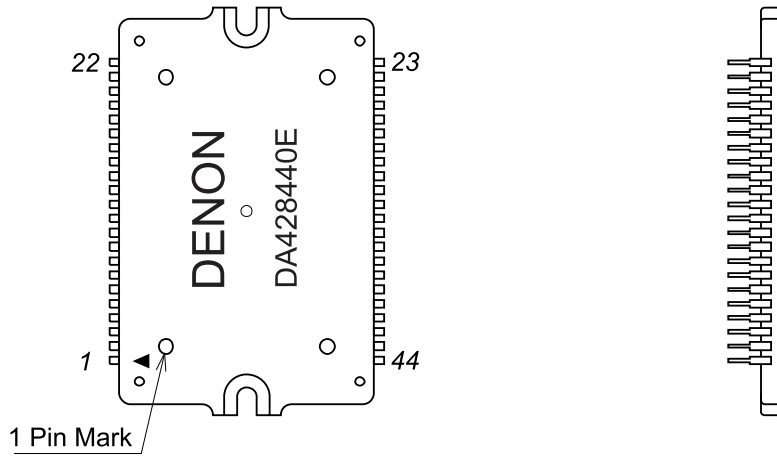

BLOCK DIAGRAM

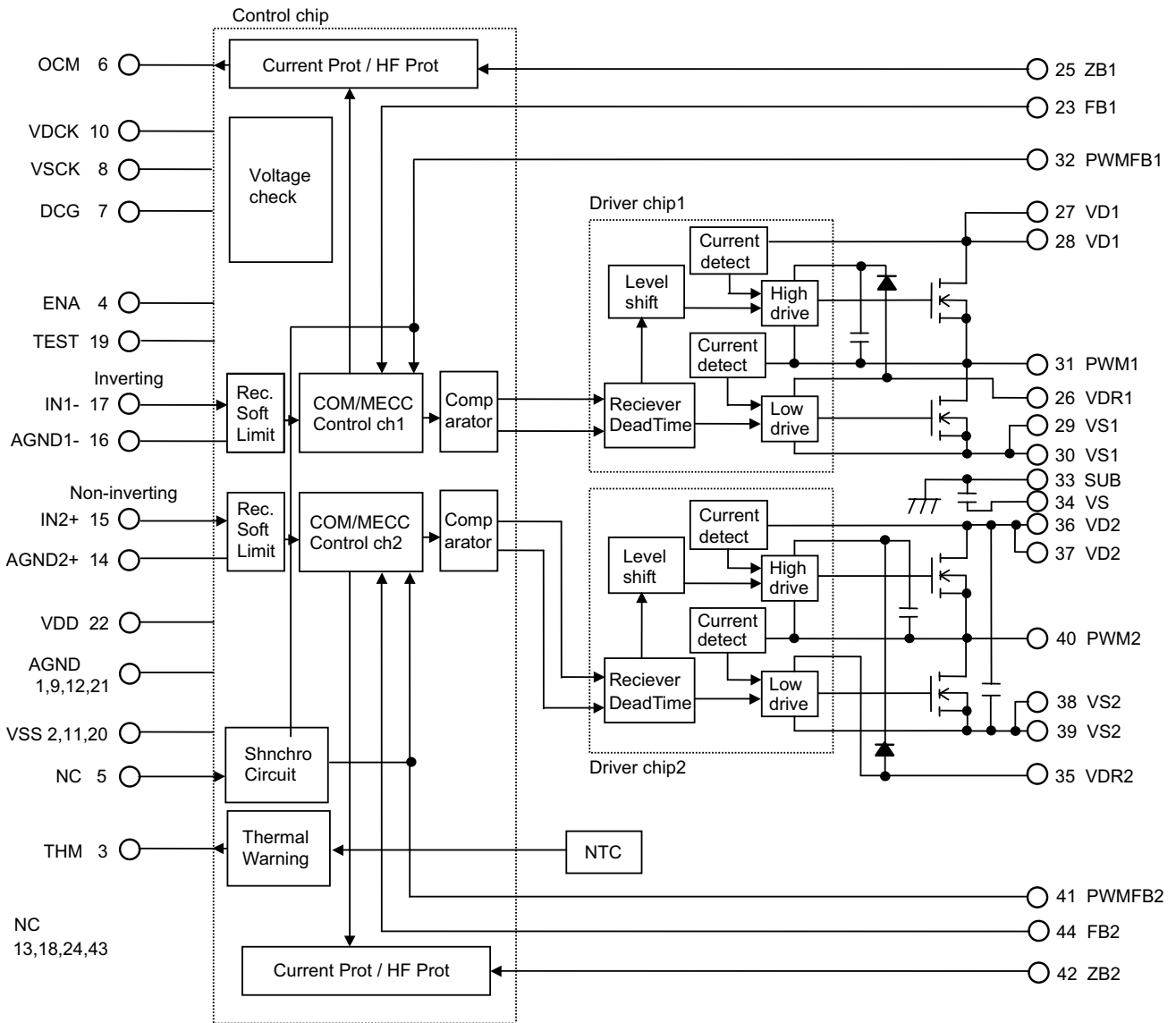

Terminl Function

Pin No.	Pin Name	Function
1	AGND	Analog ground for control chip power supply.
2	VSS	Negative power supply for control chip (-5V).
3	THM	Thermal Monitor Error signal of open collector output "L" for two conditions. 1. Over temperature limitation. 2. Over temperature warning. By connecting to the ENA pin, thermal shutdown is set.
4	ENA	Bi-direction input/output. The input "H" enables to start switching and the input "L" disables. Input is including hysteresis for glitch free enable of the system. When the protection circuit detects the over voltage condition, the open collector output turns on.
5	NC	
6	OCM	Over Current Monitor Error signal of open collector output "L" for two conditions. 1. Over current limitation. 2. For monitoring the state of control and average voltage across the zobel resistor in case of of-limit conditions.
7	DCG	This high impedance output generates a current in case of over voltage condition on the power stage voltage (VD/VS). This current is designed to turn-on a set of discharge transistors.
8	VSCK	This high impedance input for monitoring negative power stage. This monitoring controls the soft clipping circuit and the over voltage shutdown.
9	AGND	Analog ground for control chip power supply.
10	VDCK	This high impedance input for monitoring positive power stage. This monitoring controls the soft clipping circuit and the over voltage shutdown.
11	VSS	Negative power supply for control chip (-5V).
12	AGND	Analog ground for control chip power supply.
13	NC	
14	AGND2	Input reference for channel 2. This is true inverting low impedance (1kohm) input for avoiding ground loop noise.
15	IN2+	High impedance audio input for channel 2. This input is non-inverting.
16	AGND1	Input reference for channel 1. This is true non-inverting low impedance (2kohm) input for avoiding ground loop noise.
17	IN1-	High impedance audio input for channel 1. This input is inverting.
18	NC	
19	TEST	Test terminal connect to VSS.
20	VSS	Negative power supply for control chip (-5V).
21	AGND	Analog ground for control chip power supply.
22	VDD	Positive power supply for control chip (+5V).
23	FB1	Feedback for global loop of channel 1.
24	NC	
25	ZB1	For estimating the power dissipation in the zobel resistor, this input is sensing the zobel voltage via a resistive network of channel 1.
26	VDR1	Positive supply for driver chip of channel 1 with respect to VS1; (VS1+10V).
27	VD1	Positive supply for power stage of channel 1.
28	VD1	Positive supply for power stage of channel 1.
29	VS1	Negative supply for power stage of channel 1.
30	VS1	Negative supply for power stage of channel 1.
31	PWM1	PWM output of channel 1.
32	PWMFB1	Feedback for inner loop of channel 1.
33	SUB	Substrate of IMST.
34	VS	Negative supply for power stage.
35	VDR2	Positive supply for driver chip of channel 2 with respect to VS2;(VS2+10V).
36	VD2	Positive supply for power stage of channel 2.
37	VD2	Positive supply for power stage of channel 2.
38	VS2	Negative supply for power stage of channel 2.
39	VS2	Negative supply for power stage of channel 2.
40	PWM2	PWM output of channel 2.
41	PWMFB2	Feedback for inner loop of channel 2.
42	ZB2	For estimating the power dissipation in the zobel resistor, this input is sensing the zobel voltage via a resistive network of channel 2.
43	NC	
44	FB2	Feedback for global loop of channel 2.

TC94A32F (IC232, 238, 244, 250, 256, 262)

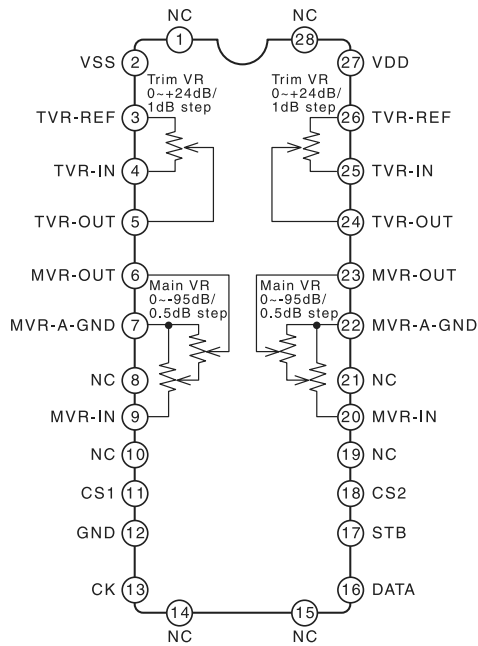

Pin No.	Pin Name	Function																														
2	VSS																															
27	VDD																															
12	GND																															
3	L-TVR-REF	Trim volume circuit L/R-TVR-REF 20kohm L/R-TVR-IN L/R-TVR-OUT																														
26	R-TVR-REF																															
4	L-TVR-IN																															
25	R-TVR-IN																															
5	L-TVR-OUT																															
24	R-TVR-OUT																															
6	L-MVR-OUT	Main volume circuit L/R-MVR-OUT 50kohm L/R-MVR-AGND 50kohm L/R-MVR-IN 20kohm																														
23	R-MVR-OUT																															
7	L-MVR-AGND																															
22	R-MVR-AGND																															
9	L-MVR-IN																															
20	R-MVR-IN																															
11	CS1	Chip select code switching input <table border="1"> <tr> <th>CS1</th> <th>CS2</th> <th colspan="4">Chip select code</th> </tr> <tr> <td>L</td> <td>L</td> <td>0</td> <td>0</td> <td>0</td> <td>1</td> </tr> <tr> <td>H</td> <td>L</td> <td>1</td> <td>0</td> <td>0</td> <td>1</td> </tr> <tr> <td>L</td> <td>H</td> <td>0</td> <td>1</td> <td>0</td> <td>1</td> </tr> <tr> <td>H</td> <td>H</td> <td>1</td> <td>1</td> <td>0</td> <td>1</td> </tr> </table>	CS1	CS2	Chip select code				L	L	0	0	0	1	H	L	1	0	0	1	L	H	0	1	0	1	H	H	1	1	0	1
CS1	CS2		Chip select code																													
L	L		0	0	0	1																										
H	L		1	0	0	1																										
L	H	0	1	0	1																											
H	H	1	1	0	1																											
18	CS2																															
13	CK	Clock input pin for data transfer																														
16	DATA	A-SW control data input pin																														
17	STB	Strobe input pin for data writing																														
1, 8, 10, 14, 15, 19, 21, 28	NC																															

CD4508BPWR (IC421~426)

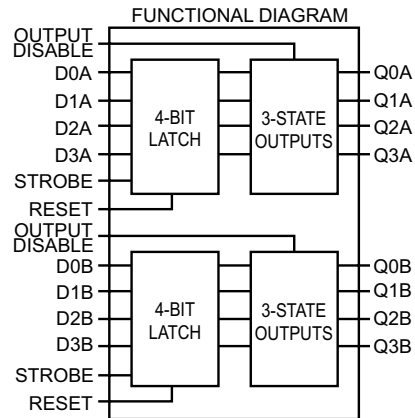
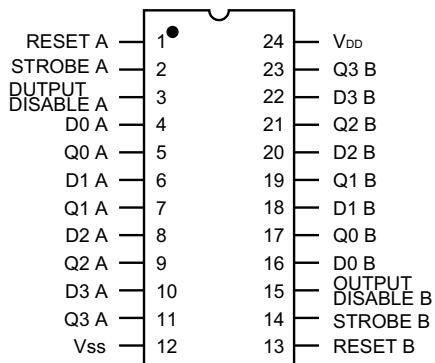

HIN202EIBNZ-T (IC801)

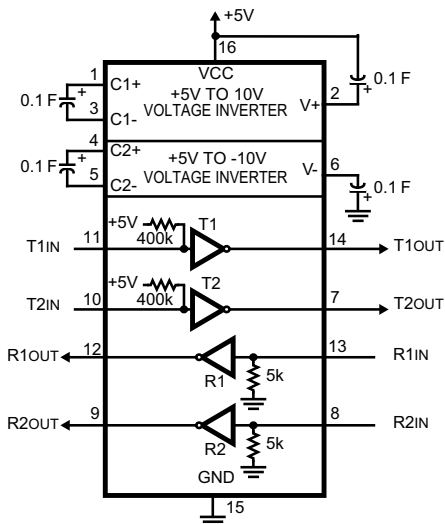
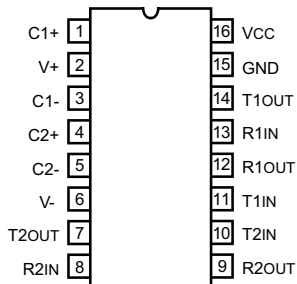

BU4052BCF (IC202, 204, 206, 208, 210, 212, 214, 216, 218, 220, 222, 224)

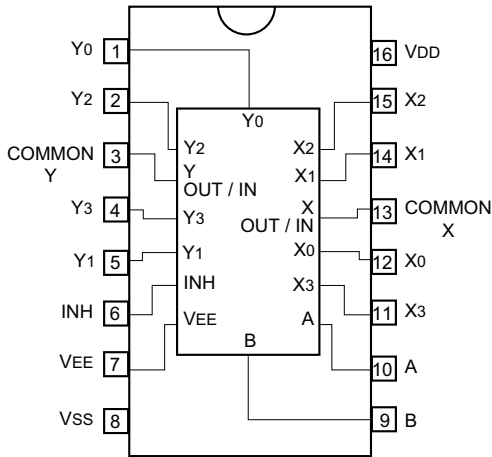

BU4053CF (IC231, 237, 243, 249, 255, 261)

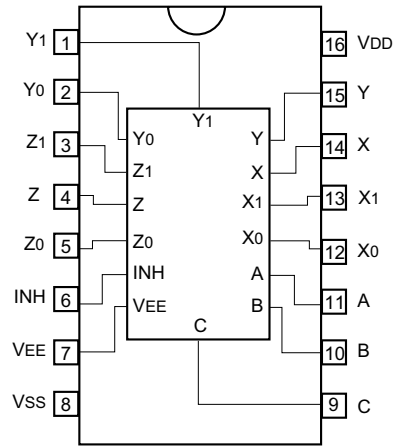

TC74HC00AF (IC409~411)

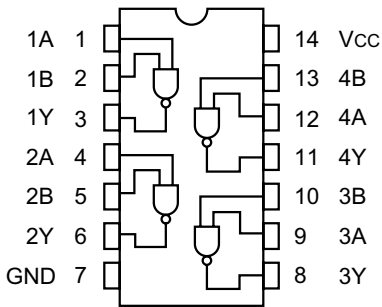

TC74VHCT08AFT (IC703, 912)

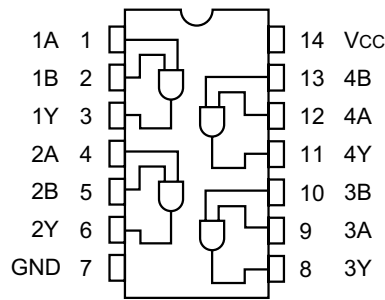

TC74VHC14FT (IC909)

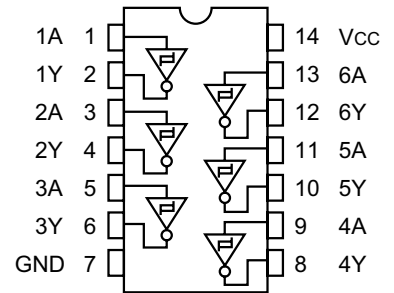

BR93L86RFVM-WTR (IC702)

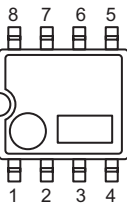

PIN No. / PIN NAME

PIN No.	PIN NAME	
1	CS	N.C.
2	SK	Vcc
3	DI	CS
4	DO	SK
5	GND	DI
6	N.C.	DO
7	N.C.	GND
8	Vcc	N.C.

BLOCK DIAGRAM

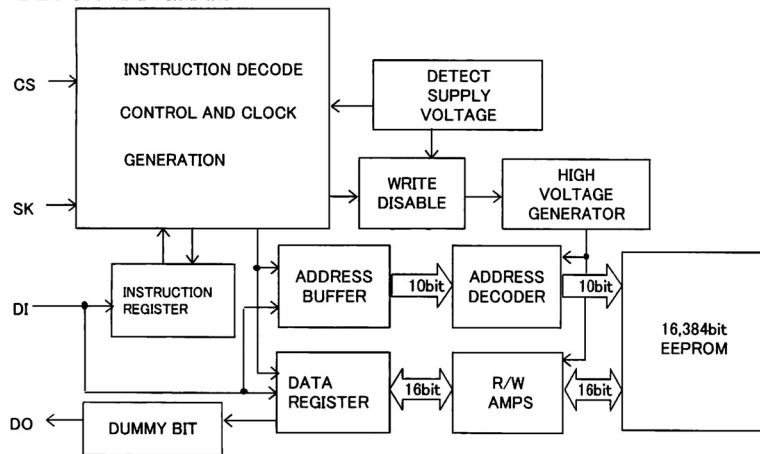

NJM5532MD (IC225, 226)
NJM2068MD-TE1 (IC201, 203, 205, 207, 209, 211, 213, 215, 217, 219, 221, 223, 233~236, 239~242, 245~248, 251~254, 257~260, 263 ~266)

■ PIN CONFIGURATION

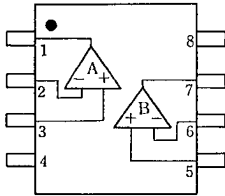

- PIN FUNCTION**
- 1. A OUTPUT
 - 2. A-INPUT
 - 3. A+INPUT
 - 4. V-
 - 5. B+INPUT
 - 6. B-INPUT
 - 7. B OUTPUT
 - 8. V+

NJM2831F (IC104)

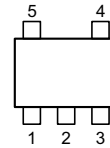

- 1. CONTROL
- 2. GND
- 3. NC
- 4. VOUT
- 5. VIN

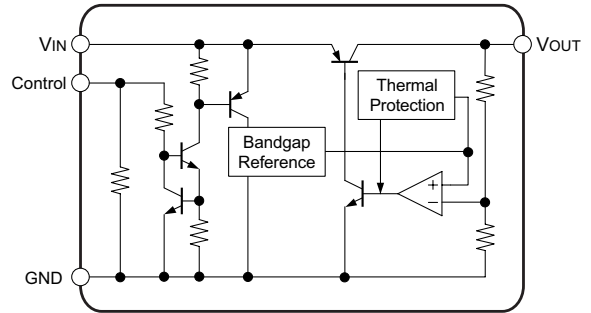

PQ070XZ01ZP (IC907)

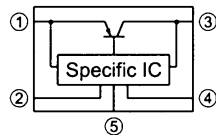
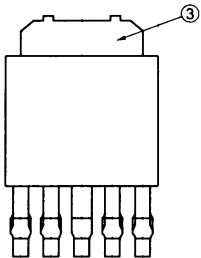

- ① DC input (VIN)
- ② ON/OFF control (Vc)
- ③ DC output (Vo)
- ④ Output voltage adjustment (VADJ)
- ⑤ GND

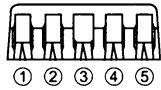

PQ1CG41H2FZ (IC101)

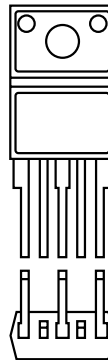

- ① VIN
- ② VOUT
- ③ COM
- ④ Oadj
- ⑤ ON/OFF control

BA033FP (IC908, 911)

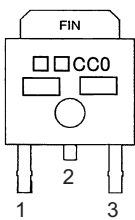

- 1: Vcc
- 2: N.C.
- 3: Vout
- FIN: GND

BLOCK DIAGRAM

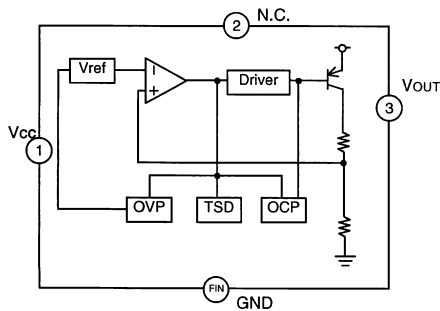

NJM7805FA(S) (IC107)
NJM7806FA(S) (IC103)
NJM7812FA(S) (IC102, 105)

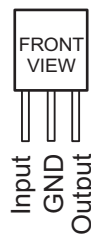

NJM7905FA(S) (IC108)
NJM7912FA(S) (IC106)

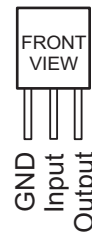

TRANSISTORS

KTA1268BL
KTC3200BL

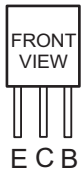

2SC4793 (Y)

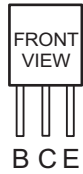

2SK373 (Y)



2SB1412

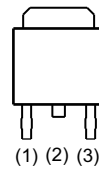

(1) Base
(2) Collector
(3) Emitter

2SC4672

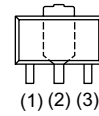

(1) Base
(2) Collector
(3) Emitter

2SA1037K(S/R)
2SC2412K(S)
2SD2114K

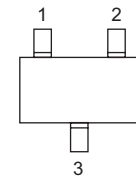

1:Emitter
2:Base
3:Collector

DTA114EK

DTC114EK
DTC114TK
DTC124EK
DTC143EK
DTC144EK
DTC343TK

TLP181

PNP Type

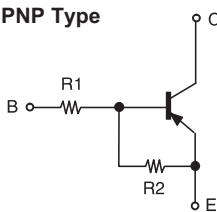

NPN Type

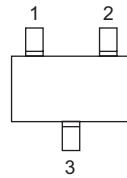
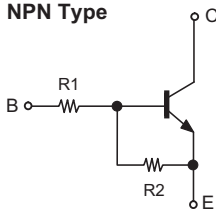

1:Emitter
2:Base
3:Collector

	R1	R2
DTA114EK	10kohm	10kohm
DTC114EK	10kohm	10kohm
DTC114TK	10kohm	—
DTC124EK	22kohm	22kohm
DTC143EK	4.7kohm	4.7kohm
DTC144EK	4.7kohm	47kohm
DTC343TK	4.7kohm	—

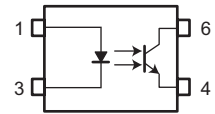

1: Anode
3: Cathode
4: Emitter
6: Collector

DIODES (LED included)

1SS270A
RK33LF-C4

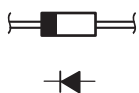

MTZJ3.3A
MTZJ7.5C
MTZJ9.1B
MTZJ22A
MTZJ24A

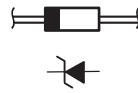

1SR35-400A

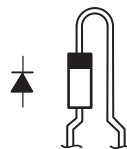

KDS160

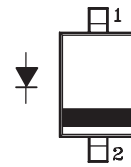

1. ANODE
2. CATHODE

UDZS 12B
UDZS 15B
UDZS 16B
UDZ 36B

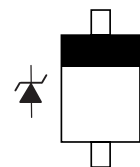

RBV-2506

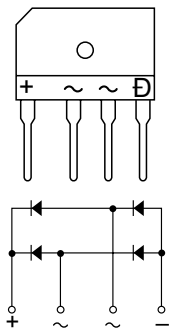

S4VB20

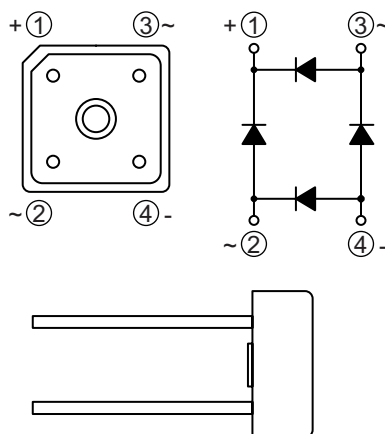

SML1216W(LED) (LD701~707)

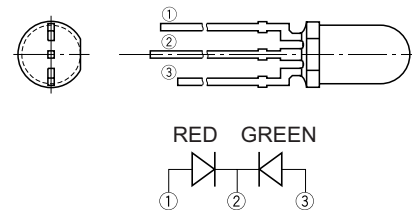

2. FL DISPLAY

FLD (HCA-19MM02T) (FR: FL701)

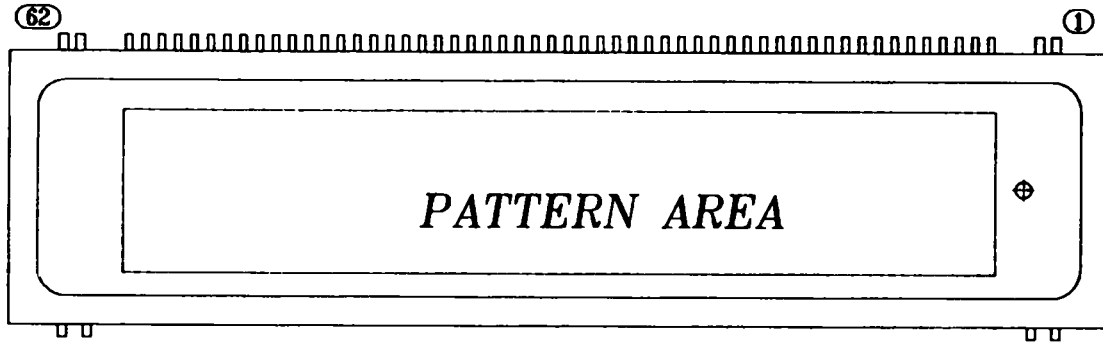

PIN CONNECTION

PIN NO.	62	61	60	59	58	57	56	55	54	53	52	51	50	49	48	47	46	45	44	43	42	41~5	4	3	2	1
CONNECTION	F2	F2	NP	NP	VDISP	L-GND	D-GND	VDD	OSCO	RESET	CS	CP	DA	DO	TEST	Q _{19G}	Q _{18G}	Q _{17G}	17G	18G	19G	NX	NP	NP	F1	F1

Notes

- 1) Fn : Filament pin
- 2) nG : Grid pin
- 3) NX : No Extended pin
- 4) NP : No pin

GRID ASSIGNMENT

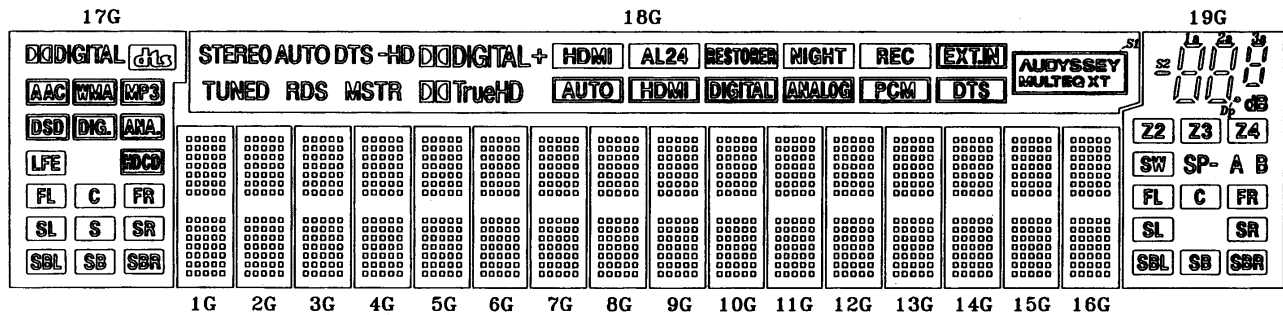

1	2	3	4	5
6	7	8	9	10
11	12	13	14	15
16	17	18	19	20
21	22	23	24	25
26	27	28	29	30
31	32	33	34	35
36	37	38	39	40
41	42	43	44	45
46	47	48	49	50
51	52	53	54	55
56	57	58	59	60
61	62	63	64	65
66	67	68	69	70

(1G~16G)

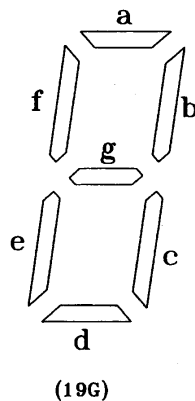

ANODE CONNECTION

	COM1~COM16	COM17	COM18	COM19
	1G~16G	17G	18G	19G
SEGB 1	1		XT	S2
SEGB 2	2		MULTIB	1a
SEGB 3	3		AUDIOSSEY	1b
SEGB 4	4		S1	1f
SEGB 5	5		DTS	1g
SEGB 6	6		EXT IN	1c
SEGB 7	7		PCM	1e
SEGB 8	8		REC	1d
SEGB 9	9	dts	ANALOG	2a
SEGB 10	10	DIGITAL	NIGHT	2b
SEGB 11	11		DIGITAL	2f
SEGB 12	12		RESTORER	2g
SEGB 13	13		HDMI	2c
SEGB 14	14		AL24	2e
SEGB 15	15		AUTO	2d
SEGB 16	16		HDMI	3a
SEGB 17	17	SP3	+	3b
SEGB 18	18	DMA	DIGITRueHD	3f
SEGB 19	19	AAC	DIGITAL	3g
SEGB 20	20		MSTR	3c
SEGB 21	21		-HD	3e
SEGB 22	22		DTS	3d
SEGB 23	23		RDS	Dp
SEGB 24	24	ANA	AUTO	dB
SEGB 25	25	DIG.	TUNED	Z2
SEGB 26	26	DSD	STEREO	Z3
SEGB 27	27			Z4
SEGB 28	28			
SEGB 29	29			
SEGB 30	30			
SEGB 31	31			
SEGB 32	32			
SEGB 33	33	DCD		
SEGB 34	34	LFE		
SEGB 35	35			

	COM1~COM16	COM17	COM18	COM19
	1G~16G	17G	18G	19G
SEGA 1	36			
SEGA 2	37			
SEGA 3	38			SW
SEGA 4	39			SP-
SEGA 5	40			A
SEGA 6	41			B
SEGA 7	42			FL
SEGA 8	43	FR		C
SEGA 9	44	C		FR
SEGA 10	45	FL		SL
SEGA 11	46			SR
SEGA 12	47			SBL
SEGA 13	48			SB
SEGA 14	49			SBR
SEGA 15	50			
SEGA 16	51	SR		
SEGA 17	52	S		
SEGA 18	53	SL		
SEGA 19	54			
SEGA 20	55			
SEGA 21	56			
SEGA 22	57			
SEGA 23	58			
SEGA 24	59	SBR		
SEGA 25	60	SB		
SEGA 26	61	SBL		
SEGA 27	62			
SEGA 28	63			
SEGA 29	64			
SEGA 30	65			
SEGA 31	66			
SEGA 32	67			
SEGA 33	68			
SEGA 34	69			
SEGA 35	70			

---MEMO---

PRINTED WIRING BOARDS
1U-3868 POWER AMP P.W.B. UNIT

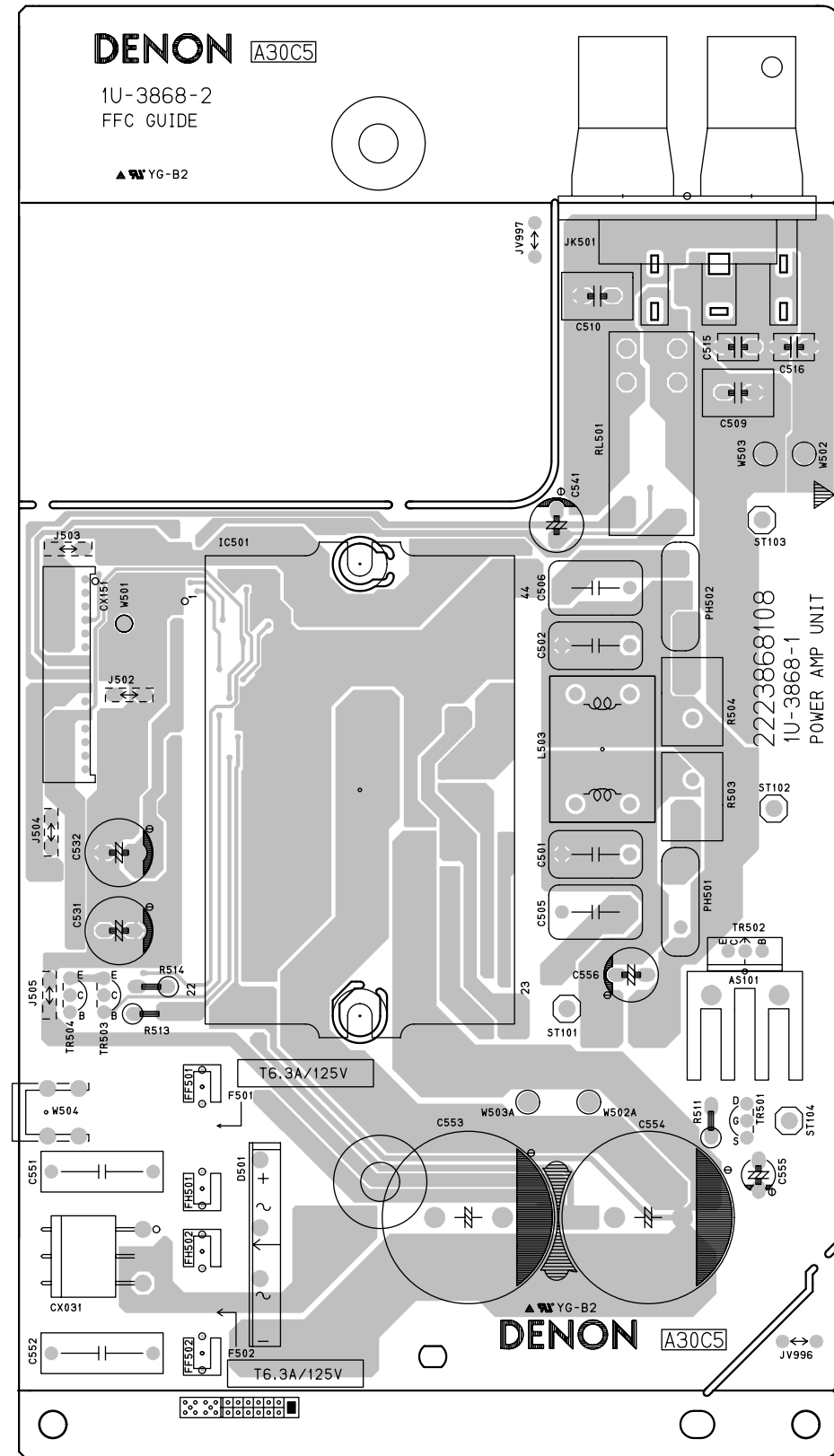

COMPONENT SIDE

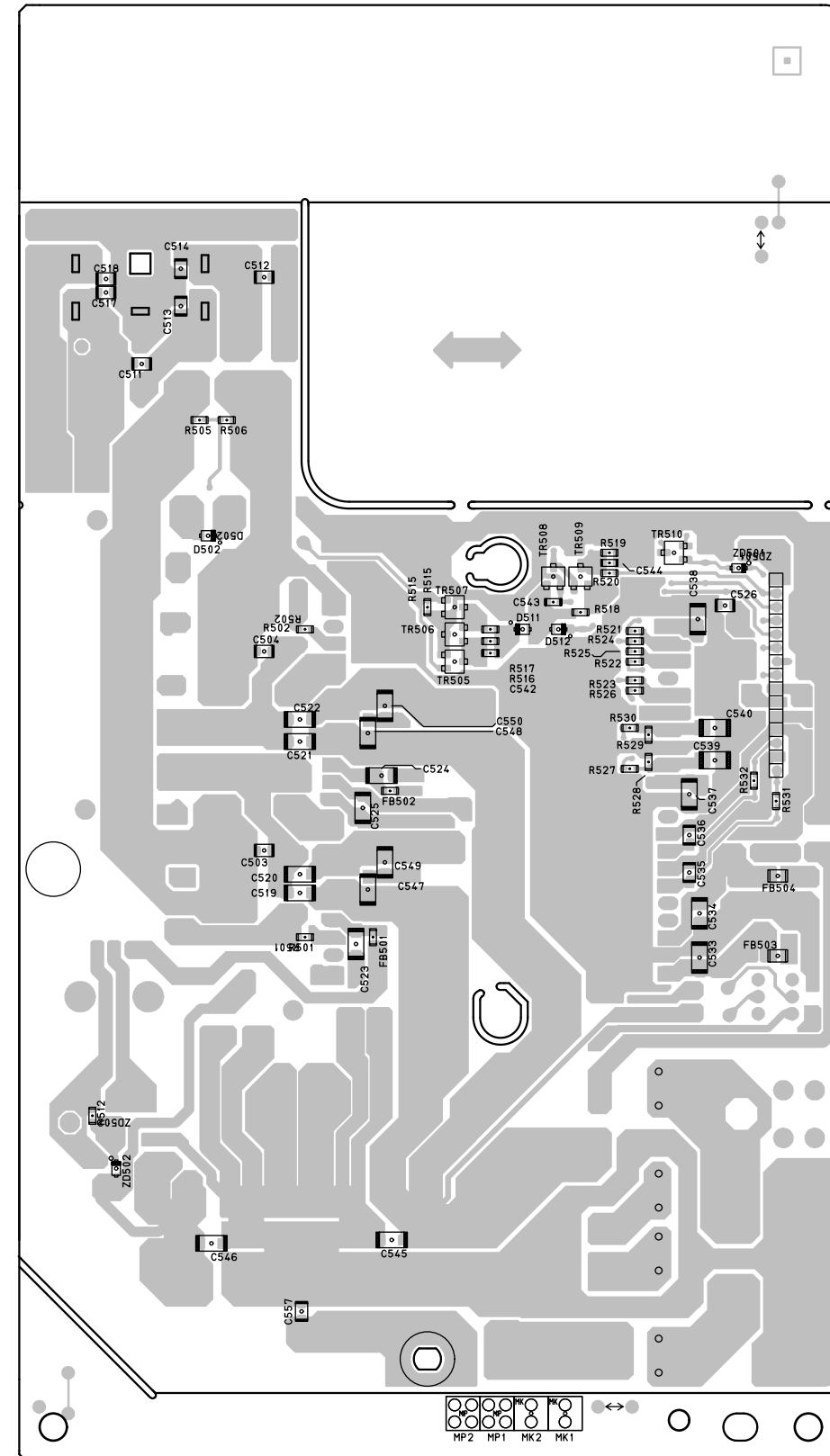

FOIL SIDE

1U-3869 ETHERNET P.W.B. UNIT

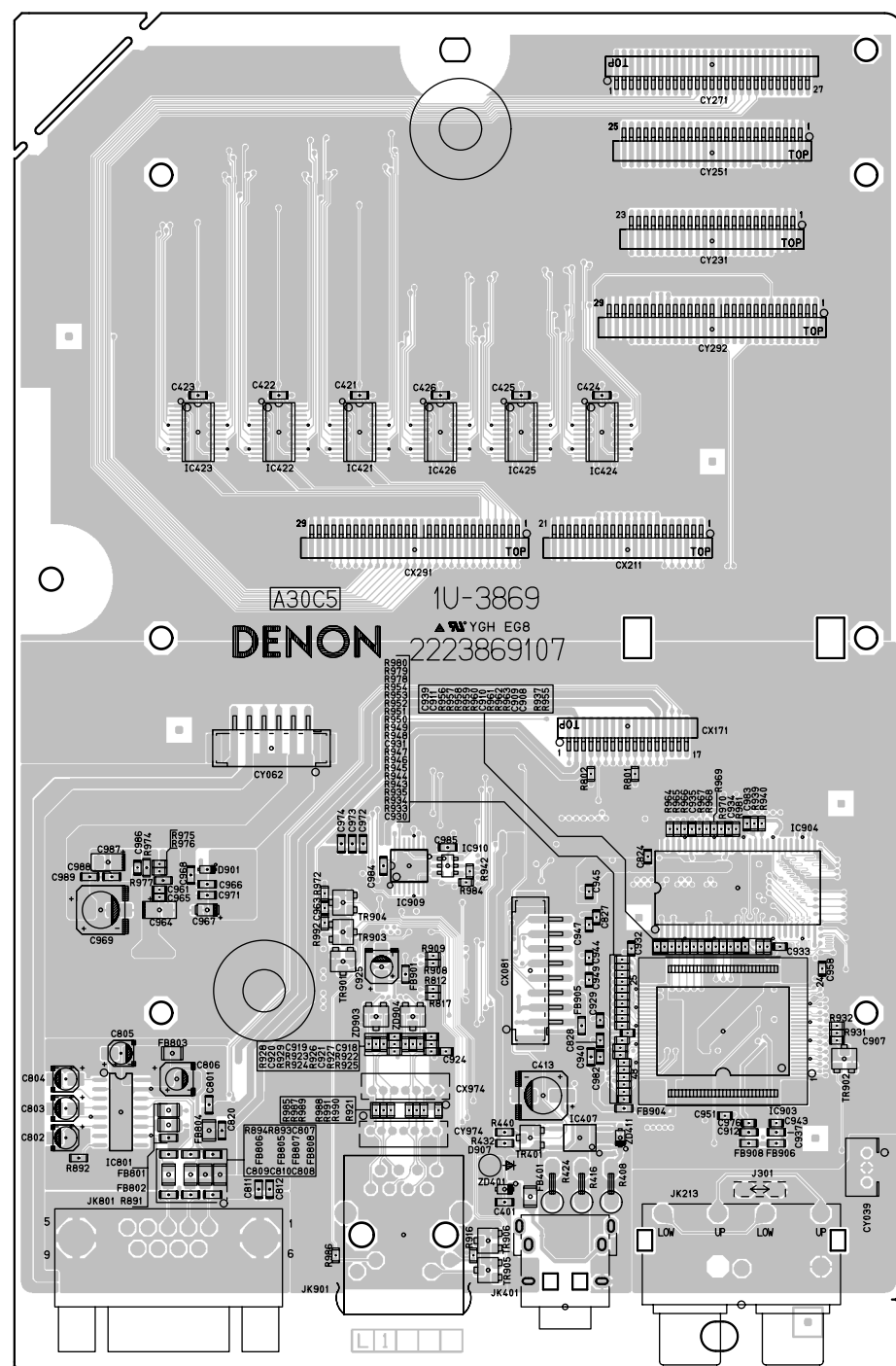

COMPONENT SIDE

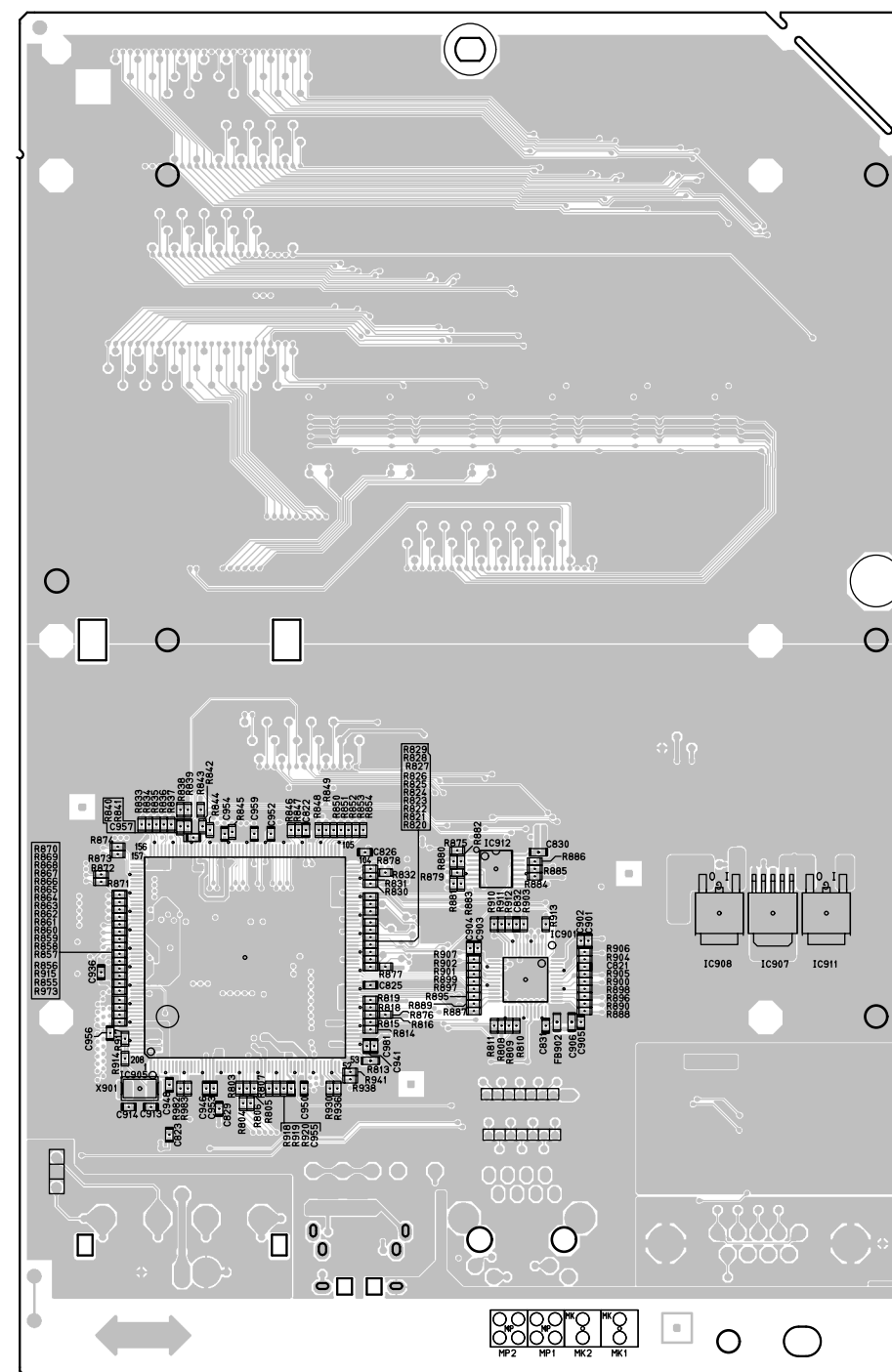

FOIL SIDE

1U-3870 INPUT P.W.B. UNIT(1/2)

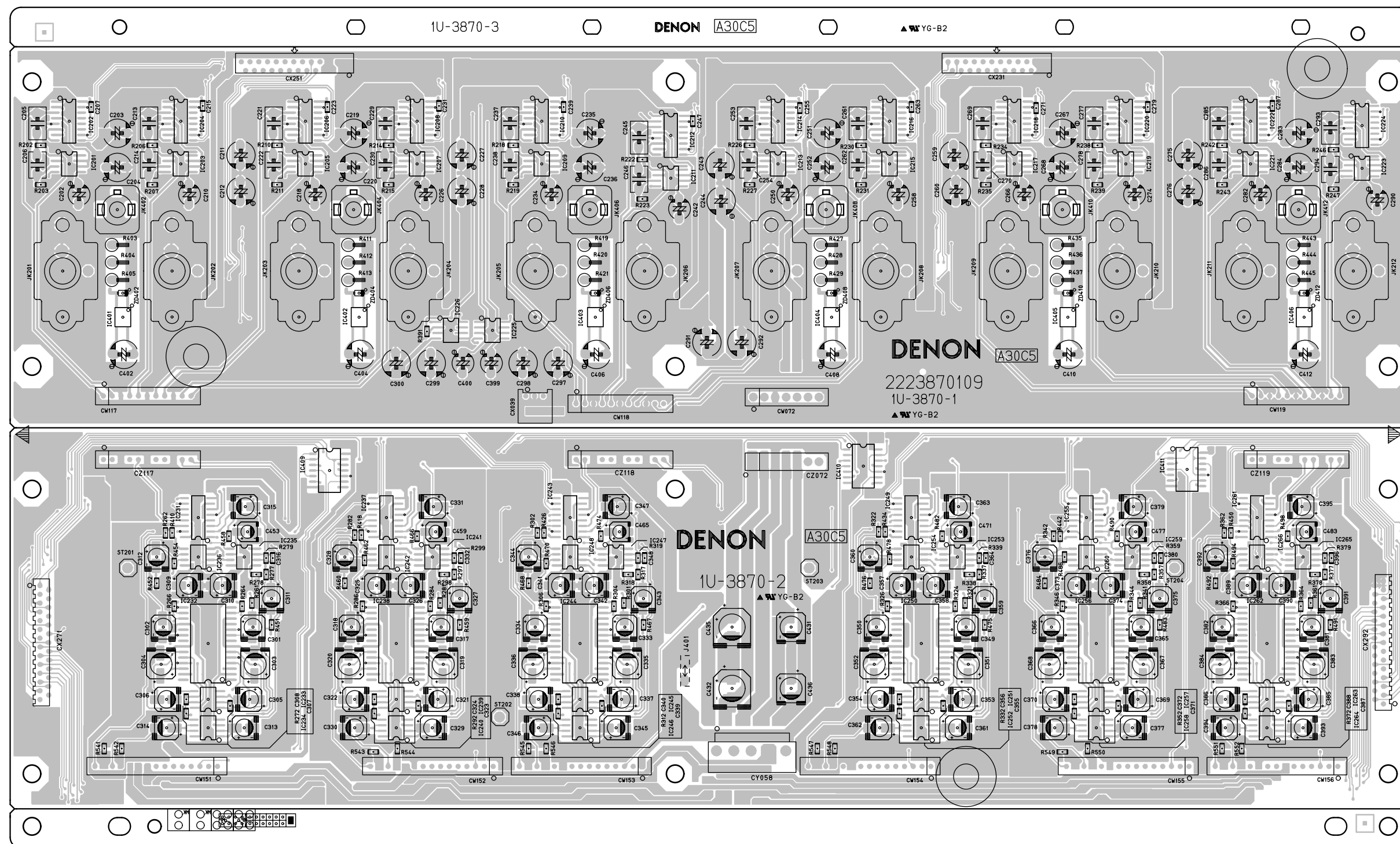

COMPONENT SIDE

1U-3870 INPUT P.W.B. UNIT(2/2)

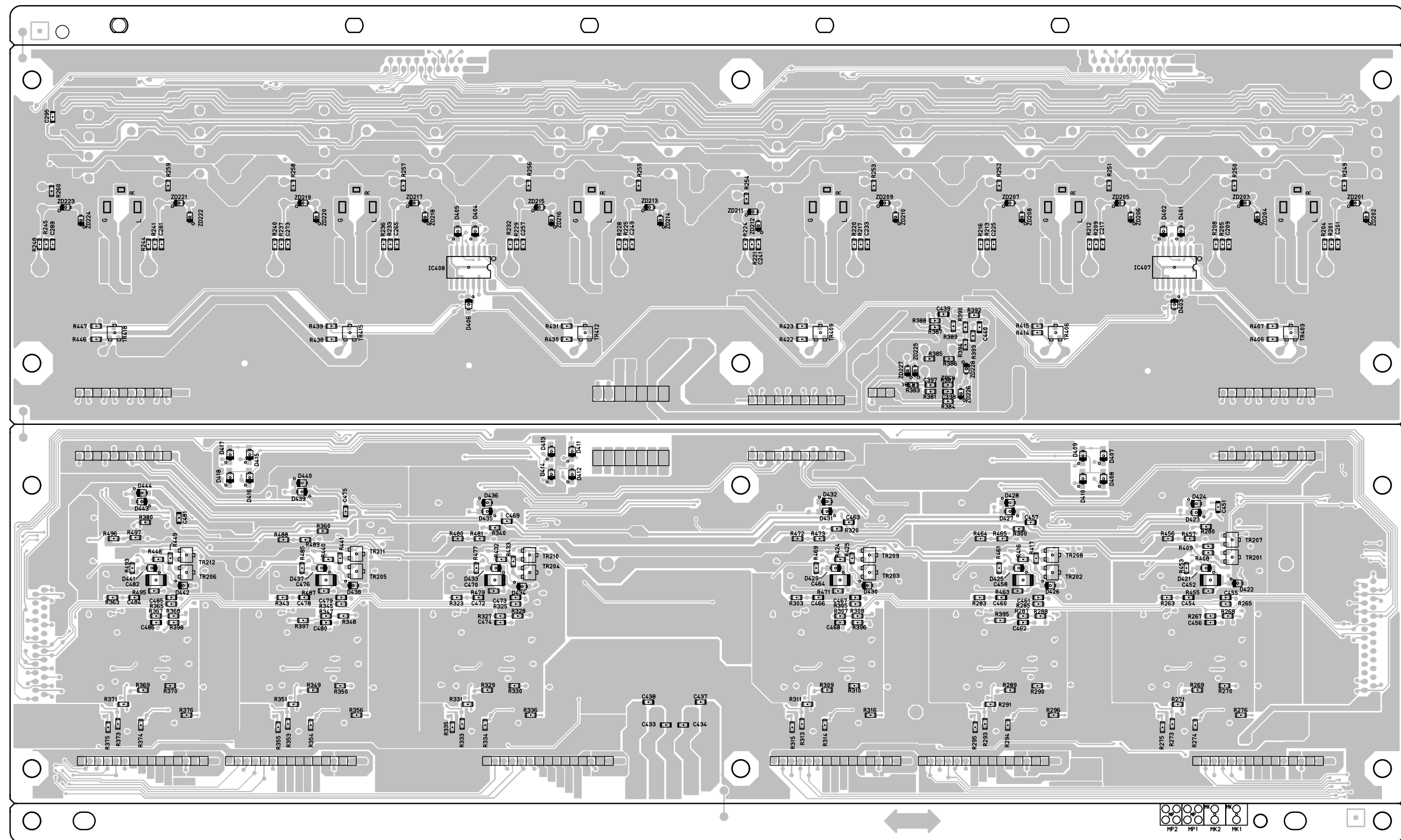

FOIL SIDE

1U-3871 MICON/FLD P.W.B. UNIT(1/2)

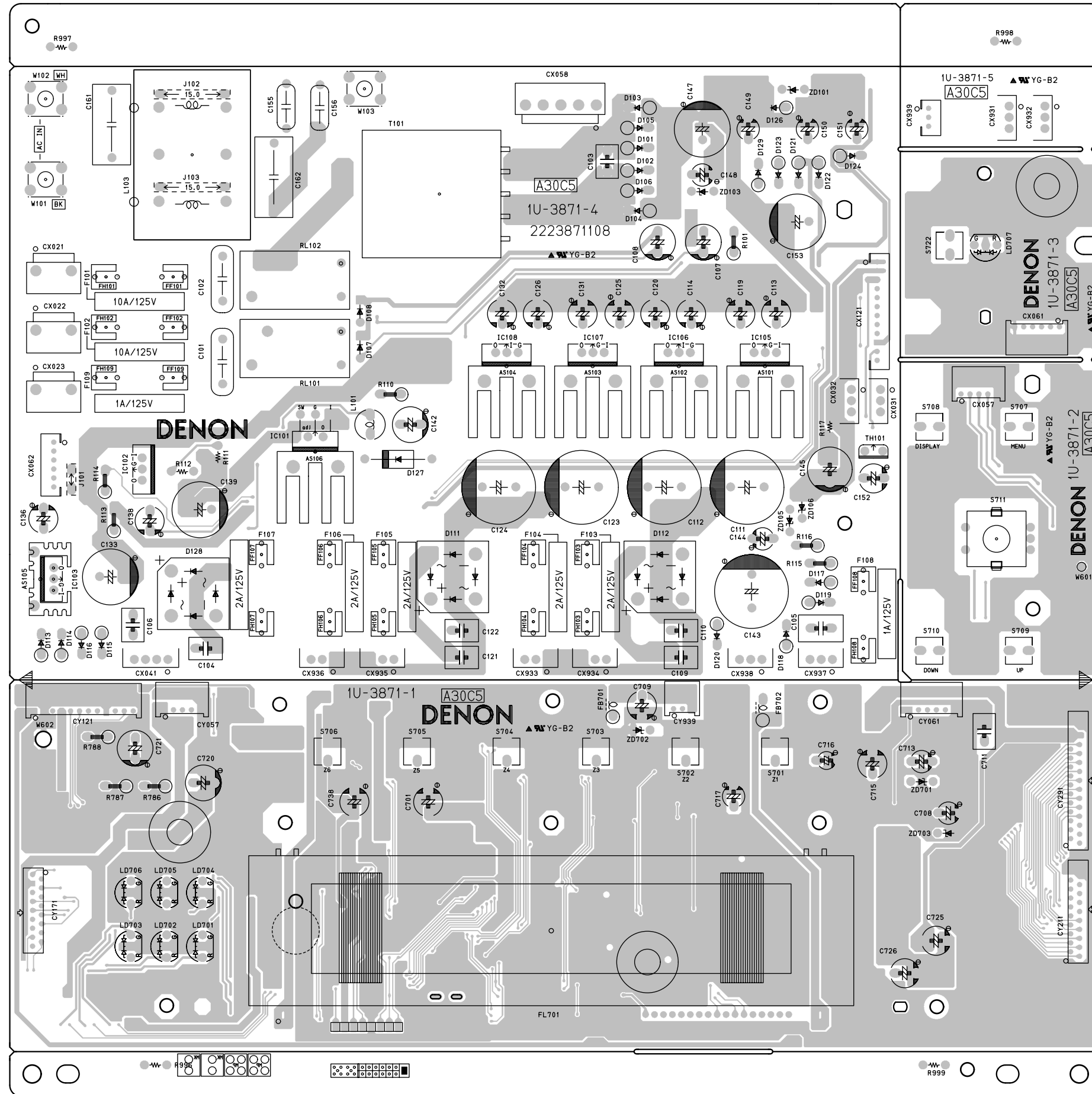

COMPONENT SIDE

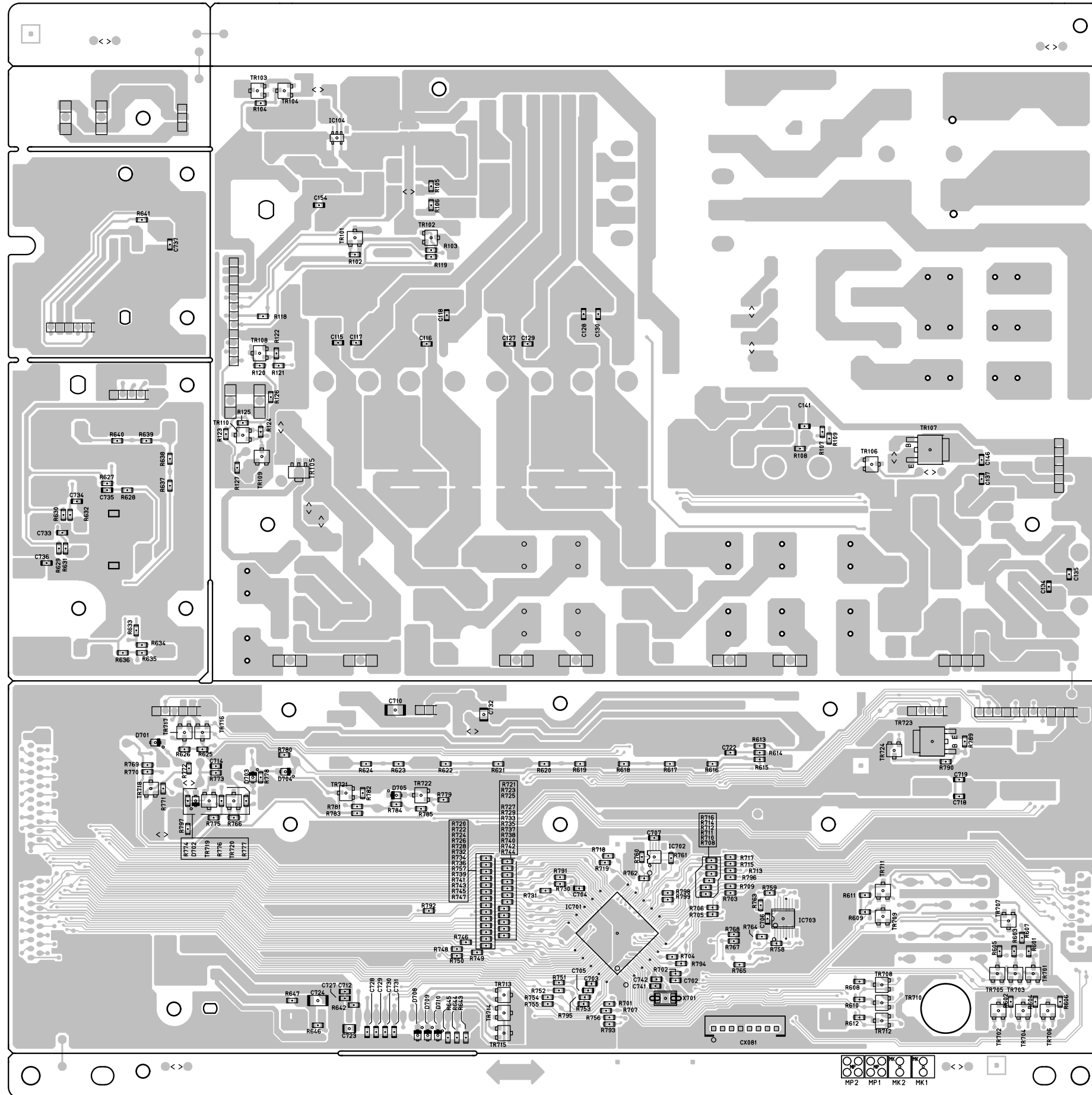

FOIL SIDE

NOTE FOR PARTS LIST

- Parts for which "nsp" is indicated on this table cannot be supplied.
 - When ordering of part, clearly indicate "1" and "I" (i) to avoid mis-supplying.
 - Ordering part without stating its part number can not be supplied.
 - Part indicated with the mark "★" is not illustrated in the exploded view.
 - Not including General-purpose Carbon Film Resistor in the P.W.Board parts list. (Refer to the Schematic Diagram for those parts.)
 - Not including General-purpose Carbon Chip Resistor in the P.W.Board parts list. (Refer to the Schematic Diagram for those parts.)
- WARNING:**
Parts marked with this symbol \triangle have critical characteristics.
Use ONLY replacement parts recommended by the manufacturer.

部品表について

- 部品表に "nsp" と記載されている部品は供給できません。
- 部品を発注する際は特に数字の "1" と英字の "I" との区別をはっきり記入してください。
- 部品番号を表示していない部品は供給できません。
- \triangle 印の部品は安全上重要な部品です。交換するときは、安全および性能維持のため必ず指定の部品をご使用ください。
- ★印のついてる部品は分解図中には記載していません。
- 汎用カーボン抵抗器は記載していません。定数は回路図を参照願います。
- 汎用カーボンチップ抵抗器は記載していません。定数は回路図を参照願います。
- 部品表の抵抗器、コンデンサの品名記号の読み方は表を参照してください。

● Resistors

Ex.: RN 14K 2E 182 G FR

Type	Shape and performance	Power	Resist-ance	Allowable error	Others
RD : Carbon RC : Composition RS : Metal oxide film RW : Winding RN : Metal film RK : Metal mixture	2B : 1/8W 2E : 1/4W 2H : 1/2W 3A : 1W 3D : 2W 3F : 3W 3H : 5W	F : ±1% G : ±2% J : ±5% K : ±10% M : ±20%	P : Pulse-resistant type NL : Low noise type NB : Non-burning type FR : Fuse-resistor F : Lead wire forming		

* Resistance

1 8 2 ⇒ 1800 ohm = 1.8 kohm
Indicates number of zeros after effective number.
2-digit effective number.

• Units: ohm

1 R 2 ⇒ 1.2 ohm
1-digit effective number.
2-digit effective number, decimal point indicated by R.

• Units: ohm

● Capacitors

Ex.: CE 04W 1H 2R2 M BP

Type	Shape and performance	Dielectric strength	Capacity	Allowable error	Others
CE : Aluminum foil electrolytic CA : Aluminum solid electrolytic CS : Tantalum electrolytic CQ : Film CK : Ceramic CC : Ceramic CP : Oil CM : Mica CF : Metallized CH : Metallized	0J : 6.3V 1A : 10V 1C : 16V 1E : 25V 1V : 35V 1H : 50V 2A : 100V 2B : 125V 2C : 160V 2D : 200V 2E : 250V 2H : 500V 2J : 630V	F : ±1% G : ±2% J : ±5% K : ±10% M : ±20% Z : +80% P : +100% C : ±0.25pF D : ±0.5pF = : Others	HS : High stability type BP : Non-polar type HR : Ripple-resistant type DL : For change and discharge HF : For assuring high frequency U : UL part C : CSA part W : UL-CSA type F : Lead wire forming		

* Capacity (electrolyte only)

2 2 2 ⇒ 2200μF
Indicates number of zeros after effective number.
2-digit effective number.

• Units: μF.

2 R 2 ⇒ 2.2μF
1-digit effective number.
2-digit effective number, decimal point indicated by R.

• Units: μF.

* Capacity (except electrolyte)

2 2 2 ⇒ 2200pF=0.0022μF
(More than 2) — Indicates number of zeros after effective number.
2-digit effective number.

• Units: pF.

2 2 1 ⇒ 220pF
(0 or 1) — Indicates number of zeros after effective number.
2-digit effective number.

• Units: pF.

• When the dielectric strength is indicated in AC, "AC" is included after the dielectric strength value.

● 抵抗器

例) RN 14K 2E 182 G FR

RN 種類	14K 形状特性	2E 電力	182 抵抗値	G 許容差	FR その他
RD : カーボン RC : 固定体 RS : 金属系皮膜 RW : 巻線 RN : 金属皮膜 RK : 金属混合体	2B : 1/8 W 2E : 1/4 W 2H : 1/2 W 3A : 1 W 3D : 2 W 3F : 3 W 3H : 5 W	F : ±1% G : ±2% J : ±5% K : ±10% M : ±20%	P : 耐パルス形 NL : 低雑音形 NB : 不燃形 FR : ヒューズ抵抗 F : リード線成形		

* 抵抗値

18 2 ⇒ 1800Ω=1.8kΩ
有効数字につづく0の数を表わす。
2桁の有効数字を表わす。

1R 2 ⇒ 1.2Ω
1桁の有効数字を表わす。
2桁の有効数字で小数点をRで表わす。
: 単位はΩ

● コンデンサ

例) CE 04W 1H 2R2 M BP

CE 種類	04W 形状特性	1H 耐圧	2R2 容量	M 許容差	BP その他
CE : アルミ箔電解 CA : アルミ固体電解 CS : タンタル電解 CQ : フィルム CK : セラミック CC : セラミック CP : オイル CM : マイカ CF : メタライズド CH : メタライズド	0J : 6.3 V 1A : 10 V 1C : 16 V 1E : 25 V 1V : 35 V 1H : 50 V 2A : 100 V 2B : 125 V 2C : 160 V 2D : 200 V 2E : 250 V 2H : 500 V 2J : 630 V	F : ±1% G : ±2% J : ±5% K : ±10% M : ±20% Z : +80% P : +100% C : ±0.25pF D : ±0.5pF = : その他	HS : 高安定形 BP : 無極性形 HR : 耐リップル形 DL : 充放電対策用 HF : 高周波保証用 U : UL 部品 C : CSA 部品 W : UL-CSA 部品 F : リード線成形		

* 容量値

● 電解コンデンサの場合

22 2 ⇒ 2200μF
有効数字につづく0の数を表わす。
2桁の有効数字を表わす。
: 単位はμF

2R 2 ⇒ 2.2μF
1桁の有効数字を表わす。
2桁の有効数字で小数点をRで表わす。
: 単位はμF

● 電解コンデンサ以外の場合

22 2 ⇒ 2200pF=0.0022μF
有効数字につづく0の数を表わす。
(0の数が2以上の場合)
2桁の有効数字を表わす。
: 単位はpF

22 1 ⇒ 220pF
有効数字につづく0の数を表わす。
(0の数が0または1の場合)
2桁の有効数字を表わす。
: 単位はpF

● 耐圧を交流で表示する場合は、耐圧表示の次に「AC」を表示します。

PARTS LIST OF P.W.B. UNIT

* 本表に "nsp" と記載されている部品は供給できません。

* Parts for which "nsp" is indicated on this table cannot be supplied.

* 本表に記載されている部品は、補修用部品のため製品に使用している部品とは一部、形状、寸法などが異なる場合があります。

* The parts listed below are for maintenance only, might differ from the parts used in the unit in appearances or dimensions.

Note: The symbols in the column "Remarks" indicate the following destinations.

E3: U.S.A. & Canada model

E2: Europe model

1U-3868 POWER AMP P.W.B. UNIT ASS'Y (E3 model)

1U-3868B POWER AMP P.W.B. UNIT ASS'Y (E2 model)

Ref. No.	Part No.	Part Name	Remarks	Q'ty	New
SEMICONDUCTORS GROUP					
	IC501	00D2640002000	DA428400-E		*
	TR501	00D2750042905	2SK373(Y)TPE2		
	TR502	00D2730423007	2SC4793-Y		
	TR503	00D2730458904	KTC3200-BL-AT/P		
	TR504	00D2710301903	KTA1268-BL-AT/P		
	TR505	00D2730384900	2SC2412KT96(S) +C		
	TR506	00D2710238908	2SA1037KT146S +C		
	TR507	00D2730384900	2SC2412KT96(S) +C		
	TR508	00D2690082902	DTC114EKT96 +C		
	TR509	00D2690083901	DTA114EKT96 +C		
	TR510	00D2690144905	DTC114YKA-T146 +C		
	D501	00D2760804007	RBV-2506		
	D502	00D2760794900	KDS160-RTK/P		
	D511,512	00D2760794900	KDS160-RTK/P		
	ZD501	00D2760683956	UDZS15B-TE17 +C		
	ZD502	00D2760683969	UDZS12B-TE17 +C		
	PH501,502	00D2790052007	NTPAD8R0LDNB0		
RESISTORS GROUP					
	R503,504	00D2432099001	RW99A3H4R7K		*
	R511	00D2412376964	RD14B2E470JNBST		
	R513,514	00D2412381946	RD14B2E472JNBST		
CAPACITORS GROUP					
	C501,502	00D2561070001	CF93B2E274JFC		*
	C503,504	nsp	CK73U2J2E222JT(2125)		
	C505,506	00D2561070014	CF93B2E394JFC		*
	C509,510	00D2554256955	CQ93P2A103JT(NH2)		
	C511-514	nsp	CK73U2J2E222JT(2125)		
	C517,518	nsp	CK73U2J2E222JT(2125)		
	C519-522	132550017523S	CK73X7R2A684KT		*
	C523-525	nsp	CK73B2A104KT-3216		
	C531,532	00D2545024002	CA04H1A221M(SA)		
	C533,534	nsp	CK73B2A104KT-3216		
	C535,536	nsp	CF73=1H102JT(ECHUB5)+2125		
	C537,538	00D2571022900	CK73B2A104KT-3216		
	C539,540	nsp	CF73=1H223JT(ECHUB5)+3225		
	C541	00D2544538968	CE04W1C331MT SMG/RE3		
	C542	nsp	CK73B1E104KT +1608		
	C544	nsp	CK73B1H102KT +1608		

	Ref. No.	Part No.	Part Name	Remarks	Q'ty	New
	C545-550	00D2571022900	CK73B2A104KT-3216			
	C551,552	00D2568038004	CF99--2EAC104M			
	C553,554	00D2546278006	CE68W1==902M(DL)			*
	C555	00D2544410921	CE04W1H100MT(KMG)			
	C556	00D2545027902	CA04H1C101MT(SA)			
OTHERS PARTS GROUP						
	CX031	nsp	3P VH CONNECTOR BASE			
	CX151	nsp	15P KR CON BASE(L)			
⚠	F501,502	00D2061046001	FUSE 6.3AUL 20MM	for E3		
⚠	F501,502	00D2061036011	FUSE (6.3A)	for E2		
	FB501,502	nsp	RM73B--0R0KT +1608			
	FB503,504	nsp	RM73B--0R0KT +2125			
	FF501,502	nsp	FUSE CLIP(TAPE)			
	FH501,502	nsp	FUSE CLIP(TAPE)			
	JK501	00D2050526011	4P SP TERMINAL(EK)			
	L503	00D2350202019	INDUCTOR(22UH X2)			
	RL501	00D2140209002	RELAY FTR-F1AD024V			
	ST102	nsp	STYLE PIN			
	ST104	nsp	STYLE PIN			
	W502,503	00D2030711008	1P SIN-SIN WIRE			
	W504	nsp	M3 SCREW TERMINAL			
		nsp	HEAT SINK			*
		00D4170476052	RADIATOR			
		nsp	ALUMINUM TAPE	for E3		
		nsp	VINYL WIRE			
		nsp	FUSE LABEL(T6.3AL)	for E2		
		nsp	3X8 CPS(SW,W) ZNP			
		nsp	3X8 CBS-B			

1U-3869 ETHERNET P.W.B. UNIT ASS'Y

(This P.W.B. UNIT ASSY is replaced by Assy level.)

Ref. No.	Part No.	Part Name	Remarks	Q'ty	New
SEMICONDUCTORS GROUP					
IC407	nsp	TLP181			
IC421-426	nsp	CD4508BPWR			*
IC801	nsp	HIN202EIBNZ-T			
IC901	nsp	RTL8201CP			
IC903	nsp	DM850 ROM SUB ASSY	S29GL064A90TFIR40		
IC904	nsp	W9812G6GH-6			
IC905	nsp	BCOIC-DM850E-CQL			
IC907	nsp	PQ070XZ01ZP +C			
IC908	nsp	BA033FP +C			
IC909	nsp	TC74VHC14FT			
IC910	nsp	SN74LVC1G373DBVR			
IC911	nsp	BA033FP +C			
IC912	nsp	TC74VHCT08AFT			
TR401	nsp	2SC2412KT96(S) +C			
TR903	nsp	KRA102S-RTK/P (10K-10K)			
TR904	nsp	KRC104S-RTK/P (47K-47K)			
TR905,906	nsp	KRC102S-RTK/P (10K-10K)			
D901	nsp	RB521S-30TE61 +REF			
D907	nsp	1SR35-400A(T93X)			
ZD401	nsp	UDZS16B-TE17 +C			
ZD411	nsp	UDZ36B-TE17			
ZD903,904	nsp	NSAD500F-T1B-A			
RESISTORS GROUP					
R408	nsp	RS14B3A222JNBST(S)			
R416	nsp	RS14B3A222JNBST(S)			
R424	nsp	RS14B3A222JNBST(S)			
R813	nsp	RM73B--5491DT(1608)			
R974	nsp	RM73B--511FT +1608			
R977	nsp	RM73B--102FT +1608			
CAPACITORS GROUP					
C401	nsp	CK73B1E104KT +1608			
C413	nsp	CE67C1H100MT (RV2)			
C421-426	nsp	CK73F1H103ZT +1608			
C801	nsp	CK73B1E104KT +1608			
C802-805	nsp	CE67C1H0R1MT (RV2B55 +REF)			
C806	nsp	CE67C1C100MT(RV2)			
C807	nsp	CK73B1E104KT +1608			
C808-810	nsp	CC73CH1H101JT +1608			
C811,812	nsp	CK73B1E104KT +1608			
C821	nsp	CK73B1H102KT +1005			
C822-829	nsp	CC73CH1H100DT +1005			
C830	nsp	CK73B1E104KT +1608			
C831,832	nsp	CK73B1A104KT +1005			
C901-903	nsp	CK73B1A104KT +1005			
C904,905	nsp	CK73B1H102KT +1005			
C906	nsp	CK73B0J475KT(P) +1608			

ご注意：
 ファームウェアをアップデートするときは、SDIで最終バージョンを確認して下さい。サービス基板はアップデートして使用下さい。

NOTE：
 When update Firmware, please confirm a last version in SDI. Use the service board after updating it.

Ref. No.	Part No.	Part Name	Remarks	Q'ty	New
C907-911	nsp	CK73B1A104KT +1005			
C912	nsp	CK73B0J475KT(P) +1608			
C913,914	nsp	CC73CH1H150JT +1005			
C918-921	nsp	CK73B1A104KT +1005			
C924	nsp	CK73B1A104KT +1005			
C925	nsp	CE67C0J220MT (RV2) +REF			
C929,930	nsp	CK73B1A104KT +1005			
C931,932	nsp	CK73B1H102KT +1005			
C933	nsp	CC73CH1H100DT +1005			
C934,935	nsp	CK73B1A104KT +1005			
C936	nsp	CK73B1H102KT +1005			
C937	nsp	CK73B0J475KT(P) +1608			
C939	nsp	CK73B1H102KT +1005			
C940	nsp	CK73B0J475KT(P) +1608			
C941	nsp	CK73B1A104KT +1005			
C943	nsp	CK73B1E103KT(1005)			
C944-951	nsp	CK73B1A104KT +1005			
C952-959	nsp	CK73B1H102KT +1005			
C961	nsp	CC73CH1H101JT +1005			
C963	nsp	CK73B1H102KT +1005			
C964	nsp	CS77B1A100MT(NOJ)			
C965	nsp	CK73B1H102KT +1005			
C966	nsp	CK73B1H102KT +1608			
C967	nsp	CS77B1A100MT(NOJ)			
C968	nsp	CK73B1H102KT +1608			
C969	nsp	CE67C1C470MT+REF			
C971	nsp	CC73CH1H101JT +1608			
C972	nsp	CK73B1E104KT +1608			
C973	nsp	CK73B1H102KT +1608			
C974	nsp	CC73CH1H101JT +1608			
C976	nsp	CK73B1E103KT(1005)			
C981	nsp	CK73B1E103KT(1005)			
C982	nsp	CK73B1A104KT +1005			
C983	nsp	CC73CH1H100DT +1005			
C984	nsp	CK73B1H102KT +1608			
C985	nsp	CK73B1E104KT +1608			
C986	nsp	CK73B1H102KT +1005			
C987	nsp	CS77B1A100MT(NOJ)			
C988	nsp	CC73CH1H101JT +1608			
C989	nsp	CK73B1H102KT +1608			
OTHERS PARTS GROUP					
CX171	nsp	17P FFC BASE(9610SC)			
CX211	nsp	21P FFC BASE(9610SC)			
CX291	nsp	29P FFC.BASE(9610SCA +REF			
CX974	nsp	6P ZR CON BASE			
CY039	nsp	3P CONN.BASE(KR-PH)			
CY062	nsp	6P PH CON.BASE +REF			
CY231	nsp	23P FFC BASE(9610SCA			
CY251	nsp	25P FFC BASE(9610)SC			
CY271	nsp	27P FFC.BASE(9610SCA +REF			
CY292	nsp	29P FFC.BASE(9610SCA +REF			
CY974	nsp	6P ZR CON BASE			

	Ref. No.	Part No.	Part Name	Remarks	Q'ty	New
	FB401	nsp	E.FIL(BLM21PG221SN1)+2125			
	FB801-808	nsp	E.FIL(BLM21PG221SN1)+2125			
	FB901,902	nsp	CHIP EMIFIL(11A121) +1608			
	FB904-906	nsp	CHIP EMIFIL(11A121) +1608			
	FB908	nsp	CHIP EMIFIL(11A121) +1608			
	JK213	nsp	YKC21-4086V 2L4P FS BK AU			
	JK401	nsp	2P MINI JACK			*
	JK801	nsp	9P D-SUB CONNECTOR			
	JK901	nsp	8P MODULAR			
	X901	nsp	FCX-03(24.576MHz)			

1U-3870 INPUT P.W.B. UNIT ASS'Y

Ref. No.	Part No.	Part Name	Remarks	Q'ty	New
SEMICONDUCTORS GROUP					
IC201	00D2630896909	NJM2068MD-TE1 +C			
IC202	00D2622012908	BU4052BCF-E2 +C			
IC203	00D2630896909	NJM2068MD-TE1 +C			
IC204	00D2622012908	BU4052BCF-E2 +C			
IC205	00D2630896909	NJM2068MD-TE1 +C			
IC206	00D2622012908	BU4052BCF-E2 +C			
IC207	00D2630896909	NJM2068MD-TE1 +C			
IC208	00D2622012908	BU4052BCF-E2 +C			
IC209	00D2630896909	NJM2068MD-TE1 +C			
IC210	00D2622012908	BU4052BCF-E2 +C			
IC211	00D2630896909	NJM2068MD-TE1 +C			
IC212	00D2622012908	BU4052BCF-E2 +C			
IC213	00D2630896909	NJM2068MD-TE1 +C			
IC214	00D2622012908	BU4052BCF-E2 +C			
IC215	00D2630896909	NJM2068MD-TE1 +C			
IC216	00D2622012908	BU4052BCF-E2 +C			
IC217	00D2630896909	NJM2068MD-TE1 +C			
IC218	00D2622012908	BU4052BCF-E2 +C			
IC219	00D2630896909	NJM2068MD-TE1 +C			
IC220	00D2622012908	BU4052BCF-E2 +C			
IC221	00D2630896909	NJM2068MD-TE1 +C			
IC222	00D2622012908	BU4052BCF-E2 +C			
IC223	00D2630896909	NJM2068MD-TE1 +C			
IC224	00D2622012908	BU4052BCF-E2 +C			
IC225,226	00D2630898907	NJM5532MD-TE1 +C			
IC231	00D2622013907	BU4053BCF-E2 +C			
IC232	00D2623168903	TC94A32F +C			
IC233-236	00D2630896909	NJM2068MD-TE1 +C			
IC237	00D2622013907	BU4053BCF-E2 +C			
IC238	00D2623168903	TC94A32F +C			
IC239-242	00D2630896909	NJM2068MD-TE1 +C			
IC243	00D2622013907	BU4053BCF-E2 +C			
IC244	00D2623168903	TC94A32F +C			
IC245-248	00D2630896909	NJM2068MD-TE1 +C			
IC249	00D2622013907	BU4053BCF-E2 +C			
IC250	00D2623168903	TC94A32F +C			
IC251-254	00D2630896909	NJM2068MD-TE1 +C			
IC255	00D2622013907	BU4053BCF-E2 +C			
IC256	00D2623168903	TC94A32F +C			
IC257-260	00D2630896909	NJM2068MD-TE1 +C			
IC261	00D2622013907	BU4053BCF-E2 +C			
IC262	00D2623168903	TC94A32F +C			
IC263-266	00D2630896909	NJM2068MD-TE1 +C			
IC401-406	00D2780014903	TLP181			
IC407-411	00D2621718902	TC74HC00AF(TP1) +C			
TR201-212	00D2690104903	DTC343TK-T146 +C			
TR403	00D2730384900	2SC2412KT96(S) +C			
TR406	00D2730384900	2SC2412KT96(S) +C			
TR409	00D2730384900	2SC2412KT96(S) +C			
TR412	00D2730384900	2SC2412KT96(S) +C			
TR415	00D2730384900	2SC2412KT96(S) +C			
TR418	00D2730384900	2SC2412KT96(S) +C			

	Ref. No.	Part No.	Part Name	Remarks	Q'ty	New
	D401-418 D421-444	00D2760794900 00D2760794900	KDS160-RTK/P KDS160-RTK/P			
	ZD201-228 ZD402	00D2760798951 00D2760696901	UDZS4.7B-TE17 UDZ36B-TE17			
	ZD404 ZD406 ZD408 ZD410 ZD412	00D2760696901 00D2760696901 00D2760696901 00D2760696901 00D2760696901	UDZ36B-TE17 UDZ36B-TE17 UDZ36B-TE17 UDZ36B-TE17 UDZ36B-TE17			
RESISTORS GROUP						
	R403-405 R411-413	00D2442043940 00D2442043940	RS14B3A222JNBST(S) RS14B3A222JNBST(S)			
	R419-421 R427-429 R435-437 R443-445	00D2442043940 00D2442043940 00D2442043940 00D2442043940	RS14B3A222JNBST(S) RS14B3A222JNBST(S) RS14B3A222JNBST(S) RS14B3A222JNBST(S)			
CAPACITORS GROUP						
	C201 C202 C203,204	nsp 00D2544194917 00D2544196986	CK73B1H152KT +1608 CE04W1E100MT (SRA) CE04W1H100MT (SRA)			
	C205 C206 C207 C209 C210	00D2551265978 00D2551265936 nsp nsp 00D2544194917	CQ93M1H223JT(B) CQ93M1H103JT(B) CK73F1H103ZT +1608 CK73B1H152KT +1608 CE04W1E100MT (SRA)			
	C211,212 C213 C214 C215 C217	00D2544196986 00D2551265978 00D2551265936 nsp nsp	CE04W1H100MT (SRA) CQ93M1H223JT(B) CQ93M1H103JT(B) CK73F1H103ZT +1608 CK73B1H152KT +1608			
	C218 C219,220 C221 C222 C223	00D2544194917 00D2544196986 00D2551265978 00D2551265936 nsp	CE04W1E100MT (SRA) CE04W1H100MT (SRA) CQ93M1H223JT(B) CQ93M1H103JT(B) CK73F1H103ZT +1608			
	C225 C226 C227,228 C229 C230	nsp 00D2544194917 00D2544196986 00D2551265978 00D2551265936	CK73B1H152KT +1608 CE04W1E100MT (SRA) CE04W1H100MT (SRA) CQ93M1H223JT(B) CQ93M1H103JT(B)			
	C231 C233 C234 C235,236 C237	nsp nsp 00D2544194917 00D2544196986 00D2551265978	CK73F1H103ZT +1608 CK73B1H152KT +1608 CE04W1E100MT (SRA) CE04W1H100MT (SRA) CQ93M1H223JT(B)			
	C238 C239 C241 C242 C243,244	00D2551265936 nsp nsp 00D2544194917 00D2544196986	CQ93M1H103JT(B) CK73F1H103ZT +1608 CK73B1H152KT +1608 CE04W1E100MT (SRA) CE04W1H100MT (SRA)			
	C245	00D2551265978	CQ93M1H223JT(B)			

	Ref. No.	Part No.	Part Name	Remarks	Q'ty	New
	C246	00D2551265936	CQ93M1H103JT(B)			
	C247	nsp	CK73F1H103ZT +1608			
	C249	nsp	CK73B1H152KT +1608			
	C250	00D2544194917	CE04W1E100MT (SRA)			
	C251,252	00D2544196986	CE04W1H100MT (SRA)			
	C253	00D2551265978	CQ93M1H223JT(B)			
	C254	00D2551265936	CQ93M1H103JT(B)			
	C255	nsp	CK73F1H103ZT +1608			
	C257	nsp	CK73B1H152KT +1608			
	C258	00D2544194917	CE04W1E100MT (SRA)			
	C259,260	00D2544196986	CE04W1H100MT (SRA)			
	C261	00D2551265978	CQ93M1H223JT(B)			
	C262	00D2551265936	CQ93M1H103JT(B)			
	C263	nsp	CK73F1H103ZT +1608			
	C265	nsp	CK73B1H152KT +1608			
	C266	00D2544194917	CE04W1E100MT (SRA)			
	C267,268	00D2544196986	CE04W1H100MT (SRA)			
	C269	00D2551265978	CQ93M1H223JT(B)			
	C270	00D2551265936	CQ93M1H103JT(B)			
	C271	nsp	CK73F1H103ZT +1608			
	C273	nsp	CK73B1H152KT +1608			
	C274	00D2544194917	CE04W1E100MT (SRA)			
	C275,276	00D2544196986	CE04W1H100MT (SRA)			
	C277	00D2551265978	CQ93M1H223JT(B)			
	C278	00D2551265936	CQ93M1H103JT(B)			
	C279	nsp	CK73F1H103ZT +1608			
	C281	nsp	CK73B1H152KT +1608			
	C282	00D2544194917	CE04W1E100MT (SRA)			
	C283,284	00D2544196986	CE04W1H100MT (SRA)			
	C285	00D2551265978	CQ93M1H223JT(B)			
	C286	00D2551265936	CQ93M1H103JT(B)			
	C287	nsp	CK73F1H103ZT +1608			
	C289	nsp	CK73B1H152KT +1608			
	C290	00D2544194917	CE04W1E100MT (SRA)			
	C291,292	00D2544196986	CE04W1H100MT (SRA)			
	C293	00D2551265978	CQ93M1H223JT(B)			
	C294	00D2551265936	CQ93M1H103JT(B)			
	C295	nsp	CK73F1H103ZT +1608			
	C297-300	00D2544196986	CE04W1H100MT (SRA)			
	C301,302	00D2544658916	CE67C1E100MT (RV2)			
	C303,304	00D2574012920	CE67C1C470MT (RV2) +REF			
	C305,306	00D2544661929	CE67C1H4R7MT (RV2) +REF			
	C307,308	nsp	CC73CH1H330JT +1608			
	C309-315	00D2544658916	CE67C1E100MT (RV2)			
	C316	00D2570503967	CC73CH1H150JT +1608			
	C317,318	00D2544658916	CE67C1E100MT (RV2)			
	C319,320	00D2574012920	CE67C1C470MT (RV2) +REF			
	C321,322	00D2544661929	CE67C1H4R7MT (RV2) +REF			
	C323,324	nsp	CC73CH1H330JT +1608			
	C325-331	00D2544658916	CE67C1E100MT (RV2)			
	C332	nsp	CC73CH1H150JT +1608			
	C333,334	00D2544658916	CE67C1E100MT (RV2)			
	C335,336	00D2574012920	CE67C1C470MT (RV2) +REF			
	C337,338	00D2544661929	CE67C1H4R7MT (RV2) +REF			
	C339,340	nsp	CC73CH1H330JT +1608			
	C341-347	00D2544658916	CE67C1E100MT (RV2)			

Ref. No.	Part No.	Part Name	Remarks	Q'ty	New
C348	nsp	CC73CH1H150JT +1608			
C349,350	00D2544658916	CE67C1E100MT (RV2)			
C351,352	00D2574012920	CE67C1C470MT (RV2) +REF			
C353,354	00D2544661929	CE67C1H4R7MT (RV2) +REF			
C355,356	nsp	CC73CH1H330JT +1608			
C357-363	00D2544658916	CE67C1E100MT (RV2)			
C364	nsp	CC73CH1H150JT +1608			
C365,366	00D2544658916	CE67C1E100MT (RV2)			
C367,368	00D2574012920	CE67C1C470MT (RV2) +REF			
C369,370	00D2544661929	CE67C1H4R7MT (RV2) +REF			
C371,372	nsp	CC73CH1H330JT +1608			
C373-379	00D2544658916	CE67C1E100MT (RV2)			
C380	nsp	CC73CH1H150JT +1608			
C381,382	00D2544658916	CE67C1E100MT (RV2)			
C383,384	00D2574012920	CE67C1C470MT (RV2) +REF			
C385,386	00D2544661929	CE67C1H4R7MT (RV2) +REF			
C387,388	nsp	CC73CH1H330JT +1608			
C389-395	00D2544658916	CE67C1E100MT (RV2)			
C396	nsp	CC73CH1H150JT +1608			
C397,398	nsp	CK73B1H152KT +1608			
C399,400	00D2544194917	CE04W1E100MT (SRA)			
C402	00D2544196986	CE04W1H100MT (SRA)			
C404	00D2544196986	CE04W1H100MT (SRA)			
C406	00D2544196986	CE04W1H100MT (SRA)			
C408	00D2544196986	CE04W1H100MT (SRA)			
C410	00D2544196986	CE04W1H100MT (SRA)			
C412	00D2544196986	CE04W1H100MT (SRA)			
C431	00D2574012920	CE67C1C470MT (RV2) +REF			
C432	00D2544658945	CE67C1E470MT (RV)			
C433,434	nsp	CK73F1H103ZT +1608			
C435	00D2544658945	CE67C1E470MT (RV)			
C436	00D2574012920	CE67C1C470MT (RV2) +REF			
C437,438	nsp	CK73F1H103ZT +1608			
C439	nsp	CC73CH1H471JT +1608			
C440	nsp	CC73CH1H331JT +1608			
C451	nsp	CK73B1H103KT (1608) +1608			
C452	nsp	CF73=1C104JT(ECHUB5)+3225			
C453	00D2544661987	CE67C1H010MT(RV2)			
C454-456	nsp	CK73B1H102KT +1608			
C457	nsp	CK73B1H103KT (1608) +1608			
C458	nsp	CF73=1C104JT(ECHUB5)+3225			
C459	00D2544661987	CE67C1H010MT(RV2)			
C460-462	nsp	CK73B1H102KT +1608			
C463	nsp	CK73B1H103KT (1608) +1608			
C464	nsp	CF73=1C104JT(ECHUB5)+3225			
C465	00D2544661987	CE67C1H010MT(RV2)			
C466-468	nsp	CK73B1H102KT +1608			
C469	nsp	CK73B1H103KT (1608) +1608			
C470	nsp	CF73=1C104JT(ECHUB5)+3225			
C471	00D2544661987	CE67C1H010MT(RV2)			
C472-474	nsp	CK73B1H102KT +1608			
C475	nsp	CK73B1H103KT (1608) +1608			
C476	nsp	CF73=1C104JT(ECHUB5)+3225			
C477	00D2544661987	CE67C1H010MT(RV2)			
C478-480	nsp	CK73B1H102KT +1608			
C481	nsp	CK73B1H103KT (1608) +1608			

Ref. No.	Part No.	Part Name	Remarks	Q'ty	New
C482	nsp	CF73=1C104JT(ECHUB5)+3225			
C483	00D2544661987	CE67C1H010MT(RV2)			
C484-486	nsp	CK73B1H102KT +1608			
OTHERS PARTS GROUP					
CW072	00D2042692115	7P SCN-SCN CON.CORD			*
CW117-119	612050018003D	11P 60mm SAN-SAN			*
CW151-156	612050019006D	15P 70mm PH-SAN			*
CX039	nsp	3P KR CON BASE(L)			
CX231	00D2051006048	23P FFC BASE(P=1)			
CX251	00D2051316000	25P FFC BASE(9610S)Y			
CX271	00D2051260033	27P FFC BASE (9610SA)			
CX292	00D2051260046	29P FFC BASE (9610SA)			
CY058	nsp	5P VH CONNECTOR BASE			
JK201-212	00D2048764005	1P PINJACK			*
JK402	00D2048765004	H/P JACK(D3.5 TOP)			*
JK404	00D2048765004	H/P JACK(D3.5 TOP)			*
JK406	00D2048765004	H/P JACK(D3.5 TOP)			*
JK408	00D2048765004	H/P JACK(D3.5 TOP)			*
JK410	00D2048765004	H/P JACK(D3.5 TOP)			*
JK412	00D2048765004	H/P JACK(D3.5 TOP)			*
ST201-204	nsp	STYLE PIN			

1U-3871 MICON/FLD P.W.B. UNIT ASS'Y (E3 model)
 1U-3871B MICON/FLD P.W.B. UNIT ASS'Y (E2 model)

Ref. No.	Part No.	Part Name	Remarks	Q'ty	New
SEMICONDUCTORS GROUP					
IC101	00D2631237004	PQ1CG41H2FZ			
IC102	00D2630801004	NJM7812FA(S)			
IC103	00D2630793002	NJM7806FA(S)			
IC104	00D2631242905	NJM2831F33			
IC105	00D2630801004	NJM7812FA(S)			
IC106	00D2630641002	NJM7912FA			
IC107	00D2630809006	NJM7805FA(S)			
IC108	00D2630554005	NJM7905FA			
IC701	00DGEN8674	PROGRAM WRITING SUB	M3062LFGPGP		*
IC702	00D2623498903	BR93L86RFVM-WTR			
IC703	00D2623410907	TC74VHCT08AFT			
TR101,102	00D2740195901	2SD2114KT196 +C			
TR103	00D2690066902	DTC323TKT96 +C			
TR104	00D2690048904	DTC143EK-T96 +C			
TR105	00D2730463902	2SC4672T100PQ +C			
TR106	00D2690102905	DTC124EKT146 +C			
TR107	00D2720127902	2SB1182 F5 TL +C			
TR108-110	00D2730384900	2SC2412KT96(S) +C			
TR701-712	00D2690088906	DTC114TKT96 +C			
TR713-715	00D2730384900	2SC2412KT96(S) +C			
TR716,717	00D2690088906	DTC114TKT96 +C			
TR718,719	00D2730384900	2SC2412KT96(S) +C			
TR721,722	00D2730384900	2SC2412KT96(S) +C			
TR723	00D2720161900	2SB1412TL(PQR) +C			
TR724	00D2690082902	DTC114EKT96 +C			
D101-106	00D2760704903	1SR35-400A(T93X)			
D107,108	00D2760432903	1SS270A TE (TAPE)			
D111,112	00D2760305001	S4VB20			
D113-123	00D2760704903	1SR35-400A(T93X)			
D124	00D2760704903	1SR35-400A(T93X)			
D126	00D2760704903	1SR35-400A(T93X)			
D127	00D2760753006	RK33 LF-C4			
D128	00D2760305001	S4VB20			
D129	00D2760704903	1SR35-400A(T93X)			
D701,702	00D2760794900	KDS160-RTK/P			
D704	nsp	RM73B--0R0KT +2125			
D705	00D2760794900	KDS160-RTK/P			
D708-710	00D2760794900	KDS160-RTK/P			
ZD101	00D2760635904	MTZJ7.5CT77			
ZD103	00D2760643983	MTZJ5.1A T77			
ZD105,106	00D2760645923	MTZJ22A T77			
ZD702	00D2760636903	MTZJ8.2BT77			
ZD703	00D2760634905	MTZJ3.3AT77			
LD701-707	00D3939645009	SML1216W(D)			
TH101	00D2790034054	PTH9M04BC222TS2F333			
TH101	nsp	P.V.C. TUBE(L=10)			
FL701	00D3938097001	FLD(HCA-19MM02T)			

ご注意：
 ファームウェアをアップデート
 するときは、SDIで最終バージョン
 を確認して下さい。
 サービス基板はアップデートし
 て使用下さい。

NOTE：
 When update Firmware, please
 confirm a last version in SDI.
 Use the service board after
 updating it.

Ref. No.	Part No.	Part Name	Remarks	Q'ty	New
FL701	nsp	FL SPACER (T=5)			
RESISTORS GROUP					
R110	00D2442051945	RS14B3A010JNBST(S)			
R113-115	00D2442051945	RS14B3A010JNBST(S)			
R116	00D2412380963	RD14B2E222JNBST			
R786	00D2442051961	RS14B3A101JNBST(S)			
R787,788	00D2412387908	RD14B2E010JNBST			
CAPACITORS GROUP					
C101,102	00D2538029739	CK45F2EAC472MC(KX)			
C103,104	00D2561058971	CF93A1H104JT (JL)			
C105	00D2561042903	CF93A2E104KT			
C106	00D2561058971	CF93A1H104JT (JL)			
C107,108	00D2544574922	CE04W1H101MT(RA3)			
C109,110	00D2561058971	CF93A1H104JT (JL)			
C111,112	00D2544403734	CE04W1E472MC(SMG)			
C113,114	00D2544541942	CE04W1E101MT SMG/RE3			
C115-118	nsp	CK73F1E104ZT +1608			
C119,120	00D2544541942	CE04W1E101MT SMG/RE3			
C121,122	00D2561058971	CF93A1H104JT (JL)			
C123,124	00D2544472707	CE04W1C472MC (SMG)			
C125,126	00D2544541942	CE04W1E101MT SMG/RE3			
C127-130	nsp	CK73F1E104ZT +1608			
C131,132	00D2546194902	CE04W1C221MT(KMG)			
C133	00D2544525764	CE04W1H102MC SMG/RE3			
C134,135	nsp	CK73B1E104KT +1608			
C136	00D2544541942	CE04W1E101MT SMG/RE3			
C137	nsp	CK73B1E104KT +1608			
C138	00D2544541942	CE04W1E101MT SMG/RE3			
C139	00D2544522796	CE04W1V102MC SMG/RE3			
C141	nsp	CK73B1H102KT +1608			
C142	00D2544638907	CE04W1C471MT H15(LXZ)			
C143	134050051203S	CE04W1J102MC(RE3)			
C144	00D2544802911	CE04W1J100MT(RA3)			
C145	00D2544396906	CE04W1J101MT(SMG)			
C146	nsp	CK73B1E104KT +1608			
C147	00D2544522796	CE04W1V102MC SMG/RE3			
C148	00D2544524943	CE04W1H010MT SMG/RE3			
C149	00D2544423905	CE04W1V470MT(KMG)			
C150	00D2544524956	CE04W1H2R2MT SMG/RE3			
C151,152	00D2544524985	CE04W1H100MT SMG/RE3			
C153	00D2544406702	CE04W1C332MC(SMG)			
C154	nsp	CK73B1H103KT (1608) +1608			
C155,156	00D2538029700	CK45F2EAC222MC (KX)			
C161,162	00D2568038017	CF99--2EAC224M	for E2		
C161,162	00D2568038004	CF99--2EAC104M	for E3		
C701	00D2544196986	CE04W1H100MT (SRA)			
C702,703	nsp	CK73B1H102KT +1608			
C704,705	nsp	CC73CH1H101JT +1608			
C706	nsp	CK73B1H102KT +1608			
C707	nsp	CK73B1H103KT (1608) +1608			
C708	00D2544196973	CE04W1H4R7MT (SRA)			
C709	00D2544196986	CE04W1H100MT (SRA)			

Ref. No.	Part No.	Part Name	Remarks	Q'ty	New
C710	00D2571022900	CK73B2A104KT-3216			
C711	00D2551279951	CQ93M1H104JT(B)			
C712	nsp	CK73B1H102KT +1608			
C713	00D2544196957	CE04W1H2R2MT (SRA)			
C714	nsp	CK73B1H103KT (1608) +1608			
C716	00D2544196915	CE04W1HR22MT (SRA)			
C718	nsp	CK73B1H103KT (1608) +1608			
C719	nsp	CK73B1H102KT +1608			
C720,721	00D2544360000	CE04W1A221M (SRA)			
C722	nsp	CK73B1H103KT (1608) +1608			
C723	00D2570003962	CC73SL1H390JT +2125			
C724	00D2571022900	CK73B2A104KT-3216			
C725	00D2544192935	CE04W1A101MT (SRA)			
C727	nsp	CK73B1E104KT +1608			
C728-731	nsp	CC73CH1H101JT +1608			
C732	00D2570037909	CK73B1E105KT +2125			
C733-735	nsp	CK73B1E104KT +1608			
C737	nsp	CK73B1H103KT (1608) +1608			
C738	00D2544196986	CE04W1H100MT (SRA)			
C741,742	nsp	CC73CH1H100DT +1608			
OTHERS PARTS GROUP					
CX021,022	nsp	2P VH CONNECTOR BASE			
CX023	nsp	2P VH CON BASE (Blue)			
CX031,032	nsp	3P EH CON BASE (YW)			
CX041	nsp	4P EH CONN. BASE(RD)			
CX057	nsp	5P KR CON BASE(L)			
CX058	nsp	5P VH CONNECTOR BASE			
CX061	nsp	6P KR CON BASE(L)			
CX062	nsp	6P CONN.BASE(KR-PH)			
CX081	nsp	8P CONN.BASE(KR-PH)			
CX121	nsp	12P CONN.BASE(KR-PH)			
CX931,932	nsp	3P EH CONNECTOR BASE			
CX933,934	nsp	3P EH CON BASE (RD)			
CX935,936	nsp	3P EH CON BASE (BU)			
CX937,938	nsp	3P EH CON BASE (BK)			
CX939	nsp	3P CONN.BASE(KR-PH)			
CY057	nsp	5P KR CON BASE(L)			
CY061	nsp	6P KR CON BASE(L)			
CY121	nsp	12P KR CON BASE(L)			
CY171	00D2051006080	17P FFC BASE(P=1)			
CY211	00D2051006022	21P FFC BASE (P=1)			
CY291	00D2051316039	29P FFC BASE(9610SB)			
CY939	nsp	3P KR CON BASE(L)			
△ F101,102	00D2061046043	FUSE (10A)	for E3		
△ F101,102	00D2061015090	FUSE (5A)	for E2		
△ F103-107	00D2061039063	FUSE 2.0A T	for E3		
△ F103-107	00D2061015061	FUSE 2A	for E2		
△ F108,109	00D2061039034	FUSE 1A	for E3		
△ F108,109	00D2061015029	FUSE 1A T	for E2		
FF101-109	nsp	FUSE CLIP(TAPE)			

	Ref. No.	Part No.	Part Name	Remarks	Q'ty	New
	FH101-109	nsp	FUSE CLIP(TAPE)			
	L101	115010008002S	INDUCTOR 100UH LHLC08			
△	L103	111010004008S	LINE FILTER HR35-332	for E2		*
△	RL101,102	00D2140241002	RELAY DL1SU TV-8			
	S701-710	00D2125611903	TACT SWITCH(TAPE H5)			
	S711	00D2120512007	ROTARY ENCODER			
	S722	00D2125611903	TACT SWITCH(TAPE H5)			
△	T101	00D2336629001	STANDBY TRANS E3	for E3		*
△	T101	00D2336545004	STANDBY TRANS E2	for E2		
	W101,102	nsp	M3 SCREW TERMINAL			
	W103	nsp	M3 SCREW TERMINAL	for E2		
	X701	00D3991038900	FCX-03(12MHZ)			
		nsp	3X8 CBS-B			
		nsp	RADIATOR			
		nsp	1P WIRE(UL1007)			
		nsp	VINYL WIRE			
		nsp	VINYL WIRE			
		nsp	RUBBER SHEET			
		nsp	FUSE LABEL(T5AL)	for E2		
		nsp	FUSE LABEL(T2AL)	for E2		
		nsp	FUSE LABEL(T1AL)	for E2		

AC INLET P.W.B. UNIT ASS'Y (E3 Only)

	Ref. No.	Part No.	Part Name	Remarks	Q'ty	New
CAPACITORS GROUP						
	C101,102	00D2538029700	CK45F2EAC222MC (KX)			
OTHERS PARTS GROUP						
	W103	nsp	1P CONTACT ASS			*
		nsp	2P CORD ASSY			*
		nsp	UL TUBE(12.7) BK			*
		nsp	ALUMINUM TAPE			

---MEMO---

EXPLODED VIEW

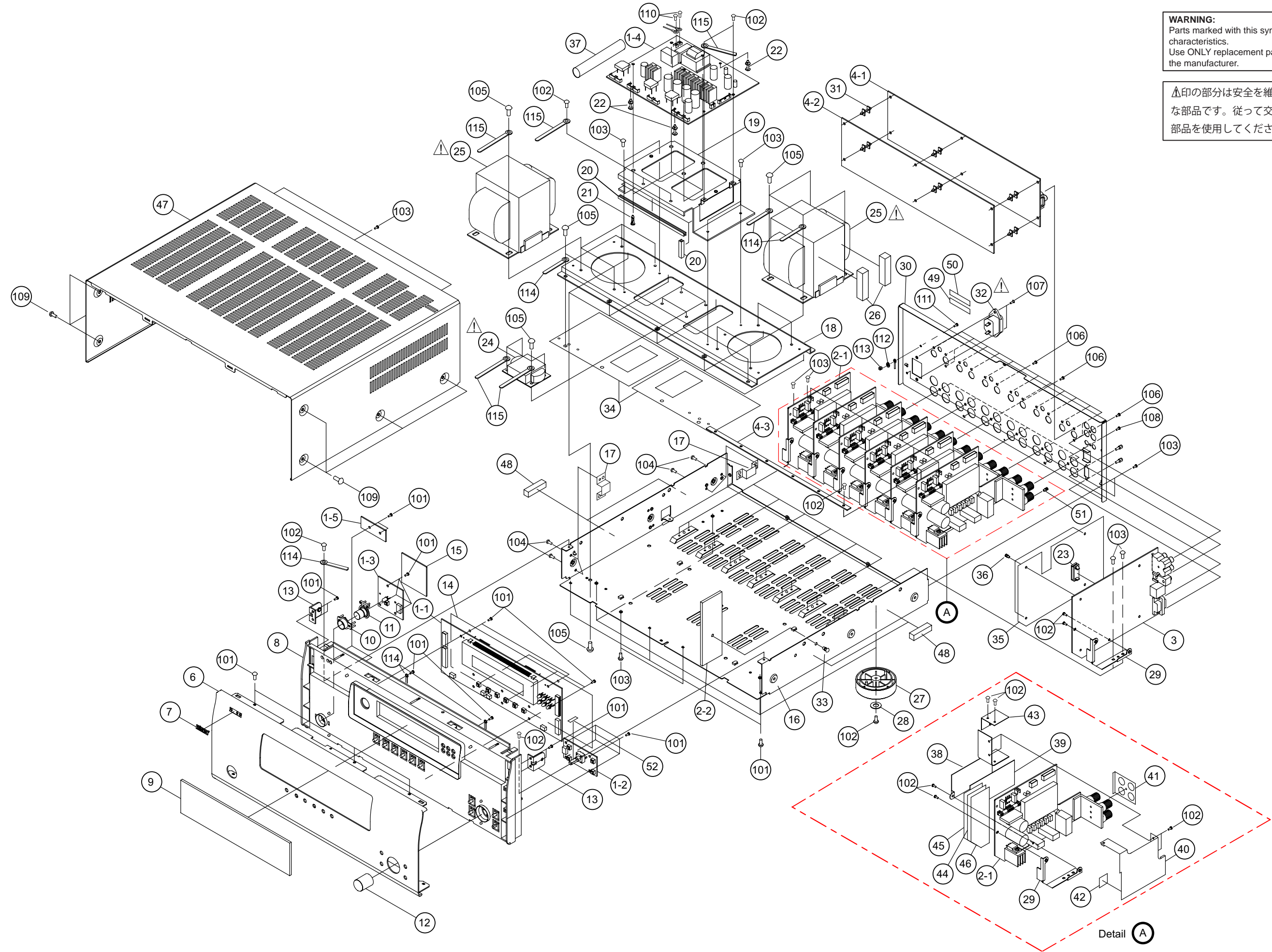

WARNING:
Parts marked with this symbol  have critical characteristics.
Use **ONLY** replacement parts recommended by the manufacturer.

印の部分は安全を維持するために重要な部品です。従って交換時は必ず指定の部品を使用してください。

PARTS LIST OF EXPLODED VIEW

* 本表に "nsp" と記載されている部品は供給できません。

* Parts for which "nsp" is indicated on this table cannot be supplied.

* 本表に "nsp" と記載されている基板 ASS'Y は供給できません。基板 ASS'Y の修理の際には基板部品表を確認のうえ、交換部品を発注してください。

* P.W.B. ASS'Y for which "nsp" is indicated on this table cannot be supplied. When repairing the P.W.B. ASS'Y, check the board parts table and order replacement parts.

* 本表に記載されている部品は、補修用部品のため製品に使用している部品とは一部、形状、寸法などが異なる場合があります。

* The parts listed below are for maintenance only, might differ from the parts used in the unit in appearances or dimensions.

Note: The symbols in the column "Remarks" indicate the following destinations.

E3 : U.S.A. & Canada model

E2 : Europe model

Ref. No.	Part No.	Part Name	Remarks	Q'ty	New	
1	nsp	MICON/FLD P.W.B. UNIT ASS'Y	for E3	1	*	
1	nsp	MICON/FLD P.W.B. UNIT ASS'Y	for E2	1	*	
1-1		MICON/FLD UNIT				
1-2		ENCORDER UNIT				
1-3		P.SW UNIT				
1-4		POWER SUPPLY UNIT				
1-5		CONNECT UNIT				
2	00D1U-3868	POWER AMP P.W.B. UNIT ASS'Y	for E3	6	*	
2	00D1U-3868B	POWER AMP P.W.B. UNIT ASS'Y	for E2	6	*	
2-1		POWER AMP UNIT				
2-2		FFC GUIDE				
3	00D1U-3869	ETHERNET P.W.B. UNIT ASS'Y		1	*	
4	nsp	INPUT UNIT		1	*	
4-1		INPUT UNIT				
4-2		AUDIO SIGNAL UNIT				
4-3		-				
6	00D1443035204	FRONT PANEL		1	*	
7	00D1310169038	DENON BADGE		1	*	
8	00D1462520004	INNER PANEL		1	*	
9	00D1431305001	FL WINDOW		1	*	
10	00D1431255009	LENS (POWER)		1		
11	00D1131992109	P.KNOB ASSY (SUB)		1		
12	00D1120933030	KNOB (S) ASSY		1		
13	nsp	PANEL BRACKET		2	*	
14	nsp	FFC GUIDE SHEET		1	*	
15	nsp	RUBBER SHEET	for E3	1	*	
16	nsp	MAIN CHASSIS		1	*	
17	nsp	SIDE BRACKET	for E3	2		
18	nsp	TRANS BRACKET		1	*	
19	nsp	POWER PWB BRACKET		1	*	
20	nsp	EDGING GEE62FAC	180mm,33mmX2	1	*	
21	nsp	LOCKING CARD SPACER		4		
22	nsp	CARD SPACER (L=12)		3		
23	nsp	FFC CLAMP LFCS30		1	*	
△	24	00D2336578000	SUB TRANS(43CIE3)	for E3	1	
△	24	00D2336580001	SUB TRANS(43CIE2)	for E2	1	
△	25	00D2336620000	POWER TRANS E3	for E3	2	*
△	25	00D2336619008	POWER TRANS E2	for E2	2	*
	26	nsp	RUBBER SHEET		2	*
	27	00D1040334007	FOOT		4	
	28	00D4610385001	RUBBER PAD		4	
	29	nsp	PWB BRACKET		7	*
	30	00D1051700141	REAR PANEL	for E3	1	*
	30	00D1051700154	REAR PANEL	for E2	1	*
	31	nsp	PWB HOLDER (WLS-10)		6	
△	32	00D2033996008	AC INLET (2P)		1	
	33	nsp	PUSH RIVET NRP450		1	*
	34	nsp	SHIELD PLATE		2	*

	Ref. No.	Part No.	Part Name	Remarks	Q'ty	New
	35	nsp	SHIELD SHEET		1	*
	36	nsp	PUSH RIVET NRP242		4	*
	37	nsp	UL TUBE (12.7)BK		1	
	38	nsp	SHIELD BRACKET		6	*
	39	nsp	INSULATING SHEET		6	*
	40	nsp	SHIELD COVER		6	*
	41	nsp	GND PLATE		6	*
	42	nsp	INSULATING SHEET		6	*
	43	nsp	SHIELD PLATE AMP1		6	*
	44	nsp	SHIELD PLATE		6	*
	45	nsp	INSULATING AMP1		6	*
	46	nsp	INSULATING AMP2		6	*
	47	00DGEN8688	TOP COVER SUB ASSY		1	
	48	nsp	EMIGASKET RFSG070100	30mmX4	1	
	49	nsp	SERIAL NO. SHEET		1	
	50	00DGEN8341	MAC ADDRESS SUB ASSY		1	
	51	nsp	SP RIVET	for E2	24	
	52	nsp	CHUKOH TAPE	30mm	1	
	★ 53	nsp	ALUMINUM TAPE		1	
	★ 54	nsp	UL TUBE (12.7)BK		1	*
	★ 55	00D3420046007	FERRITE(ZCAT1518)		1	
	★ 56	nsp	ALUMINUM TAPE	for E2	1	
	★ 61	nsp	2P CORD ASSY	for E3 W101,W102	1	*
	★ 62	nsp	1P CONTACT ASS	for E3 W103	1	*
	★ 63	nsp	1P(F3)CORD ASSY	for E2 W101	1	*
	★ 64	nsp	1P(F3)CORD ASSY	for E2 W102	1	*
	★ 65	nsp	3P PH-PH CON.CORD	CN039	1	
	★ 66	606050014006S	FFC 23P 500mm 1mm	CN231	1	*
	★ 67	606050015009S	FFC 25P 320mm 1mm	CN251	1	*
	★ 68	606050016002S	FFC 27P 200mm 1mm	CN271	1	*
	★ 69	606050017005S	FFC 29P 550mm 1mm	CN292	1	*
	★ 70	nsp	1P CONTACT ASS	W-103	1	*
	★ 71	nsp	5P VH-VH CON.CORD	CN058	1	*
	★ 72	nsp	6P KR-KR RIBBON 650	CN062	1	*
	★ 73	nsp	FFC 17P 340mm 1mm	CN171	1	*
	★ 74	nsp	FFC 21P 580mm 1mm	CN211	1	*
	★ 75	nsp	FFC 29P 600mm 1mm	CN291	1	*
	★ 76	nsp	3P KR-KR RIBBON 200	CN939	1	
	★ 77	nsp	5P KR-KR RIBBON 70	CN057	1	
	★ 78	nsp	6P KR-KR RIBBON 80	CN061	1	
	★ 79	nsp	12P KR-KR RIBBON 175	CN121	1	
	★ 80	nsp	6P 150mm ZH-ZH	CX974-CY974	1	*
SCREWS						
	101	ORD4737500015	3X8 CBTS(P)-Z		26	
	102	ORD4737002005	3X6 CBTS(S)-Z		54	
	103	ORD4737015005	3X6 CBTS(S)-B		27	
	104	ORD4737003020	3X6 CFTS(S)-B	for E3	4	
	105	ORD4737007000	4X8 CBTS (S)-B		22	
	106	00D4770064107	FIXING SCREW		21	
	107	ORD4737003017	3X8 CFTS (S)-B		2	
	108	ORD4737508004	3X6 CBTS (P)-B		1	

	Ref. No.	Part No.	Part Name	Remarks	Q'ty	New
	109	ORD4738064000	4X8 CBTS (B)-B-3P	for E3 (Serial No. 1~330)	8	
	109	ORD4770263005	3P SWELLING SCREW	for E3 (Serial No. 331~)	8	
	109	ORD4770263005	3P SWELLING SCREW	for E2	8	
	110	ORD4700009022	3X6 CPS (SW.W) ZNP	for E2	3	
	110	ORD4700009022	3X6 CPS (SW.W) ZNP	for E3	2	
	111	ORD4719012013	3X6 CBS Z(BLACK)	for E3	1	
	112	ORD4752003005	3SW	for E3	1	
	113	ORD4756006008	3N	for E3	1	
	114	ORD4450048016	CORD HOLDER (L50)		6	
	115	ORD4450048003	CORD HOLDER (L76)		6	

PACKING VIEW

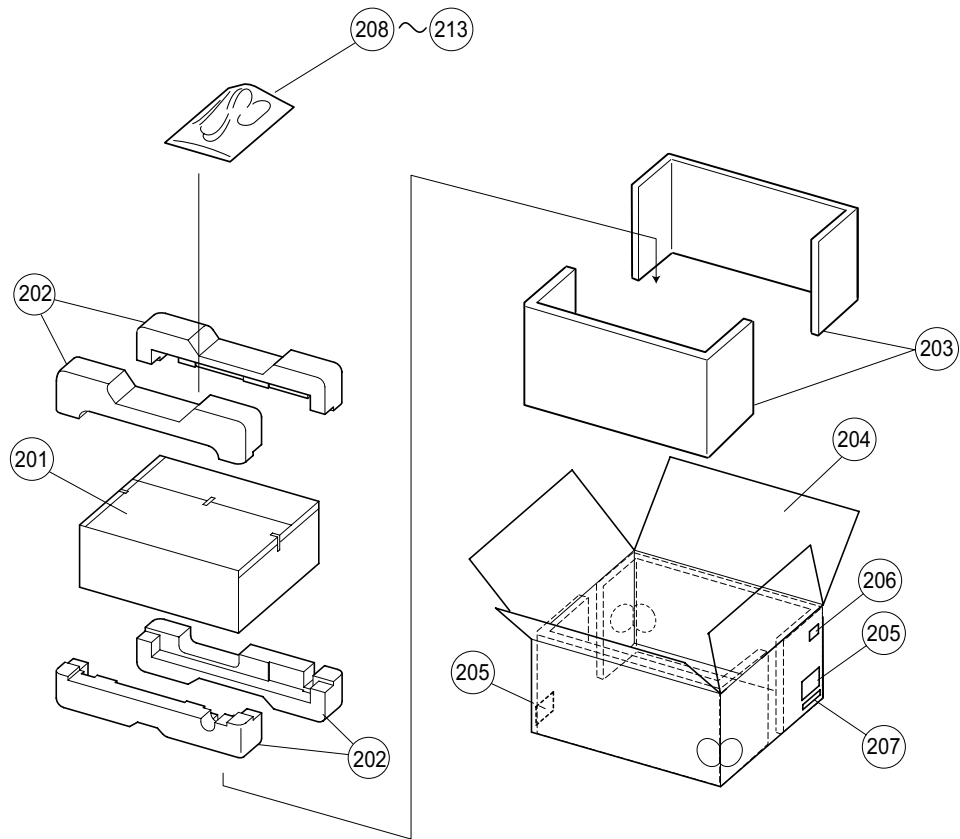

PARTS LIST OF PACKING & ACCESSORIES

* 本表に "nsp" と記載されている部品は供給できません。

* Parts for which "nsp" is indicated on this table cannot be supplied.

* 本表に記載されている部品は、補修用部品のため製品に使用している部品とは一部、形状、寸法などが異なる場合があります。

* The parts listed below are for maintenance only, might differ from the parts used in the unit in appearances or dimensions.

Note: The symbols in the column "Remarks" indicate the following destinations.

E3 : U.S.A. & Canada model

E2 : Europe model

	Ref. No.	Part No.	Part Name	Remarks	Q'ty	New
	201	nsp	CABINET SHEET		1	
	202	00D5031544022	CUSHION ASSY		1	*
	203	00D5012382038	CARTON CASE		1	*
	204	nsp	SPACER		2	
	205	nsp	CONT.CARD(L) SUB ASSY		1	
	206	nsp	BAR CODE LABEL ASSY		1	
	207	nsp	MAC ADDRESS SUB ASSY		1	
	208	nsp	ENVELOPE		1	
	209	00D5114719004	INST. MANUAL		1	*
△	210	00D2062219002	AC CORD SET(E3)	for E3	1	
△	210	00D2062215006	AC CORD-E1/10A/INLET	for E2	1	
	211	nsp	POLY COVER		1	
	212	nsp	S.S.LIST(EX)		1	
	213	nsp	WARRANTY (HOME)	for E3	1	

WIRING DIAGRAM

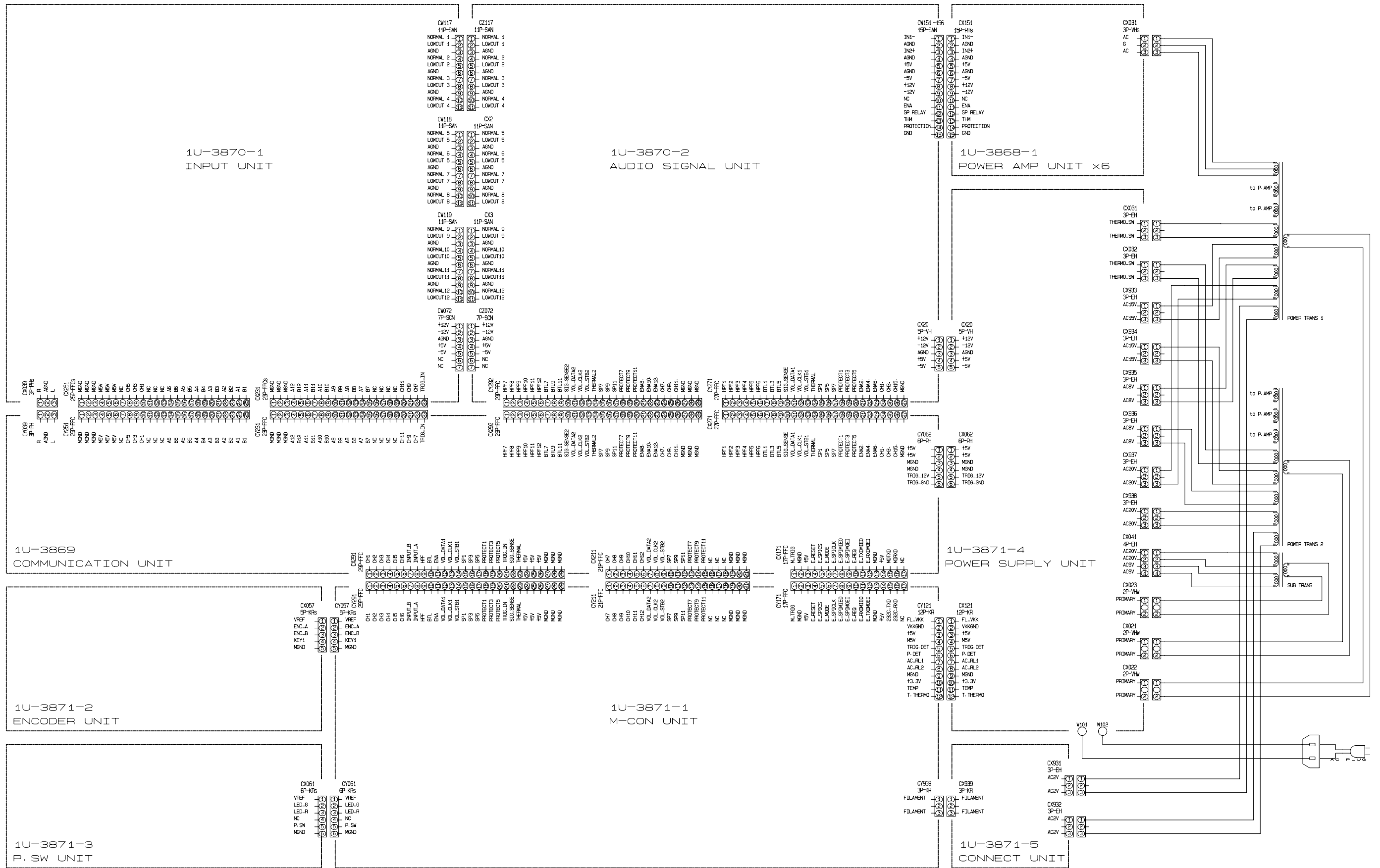

NOTE FOR SCHEMATIC DIAGRAM

WARNING:

Parts marked with this symbol \triangle have critical characteristics. Use ONLY replacement parts recommended by the manufacturer.

CAUTION:

Before returning the unit to the customer, make sure you make either (1) a leakage current check or (2) a line to chassis resistance check. If the leakage current exceeds 0.5 milliamps, or if the resistance from chassis to either side of the power cord is less than 460 kohms, the unit is defective.

WARNING:

DO NOT return the unit to the customer until the problem is located and corrected.

NOTICE:

ALL RESISTANCE VALUES IN OHM. k=1,000 OHM
M=1,000,000 OHM
ALL CAPACITANCE VALUES IN MICRO FARAD.
P=MICRO-MICRO FARAD
EACH VOLTAGE AND CURRENT ARE MEASURED AT
NO SIGNAL INPUT CONDITION.
CIRCUIT AND PARTS ARE SUBJECT TO CHANGE
WITHOUT PRIOR NOTICE.

配線図について

\triangle 印の部品は安全を維持するために重要な部品です。
従って交換時は必ず指定の部品を使用してください。

注)

- (1) 指定なき抵抗値は Ω 、k は $k\Omega$ 、M は $M\Omega$ を示す。
- (2) 指定なきコンデンサーの値は μF 、p は pF を示す。
- (3) 各部の電圧は無信号の値を示す。
- (4) この配線図は基本配線図です。改良等のため変更することがありますのでご了承ください。

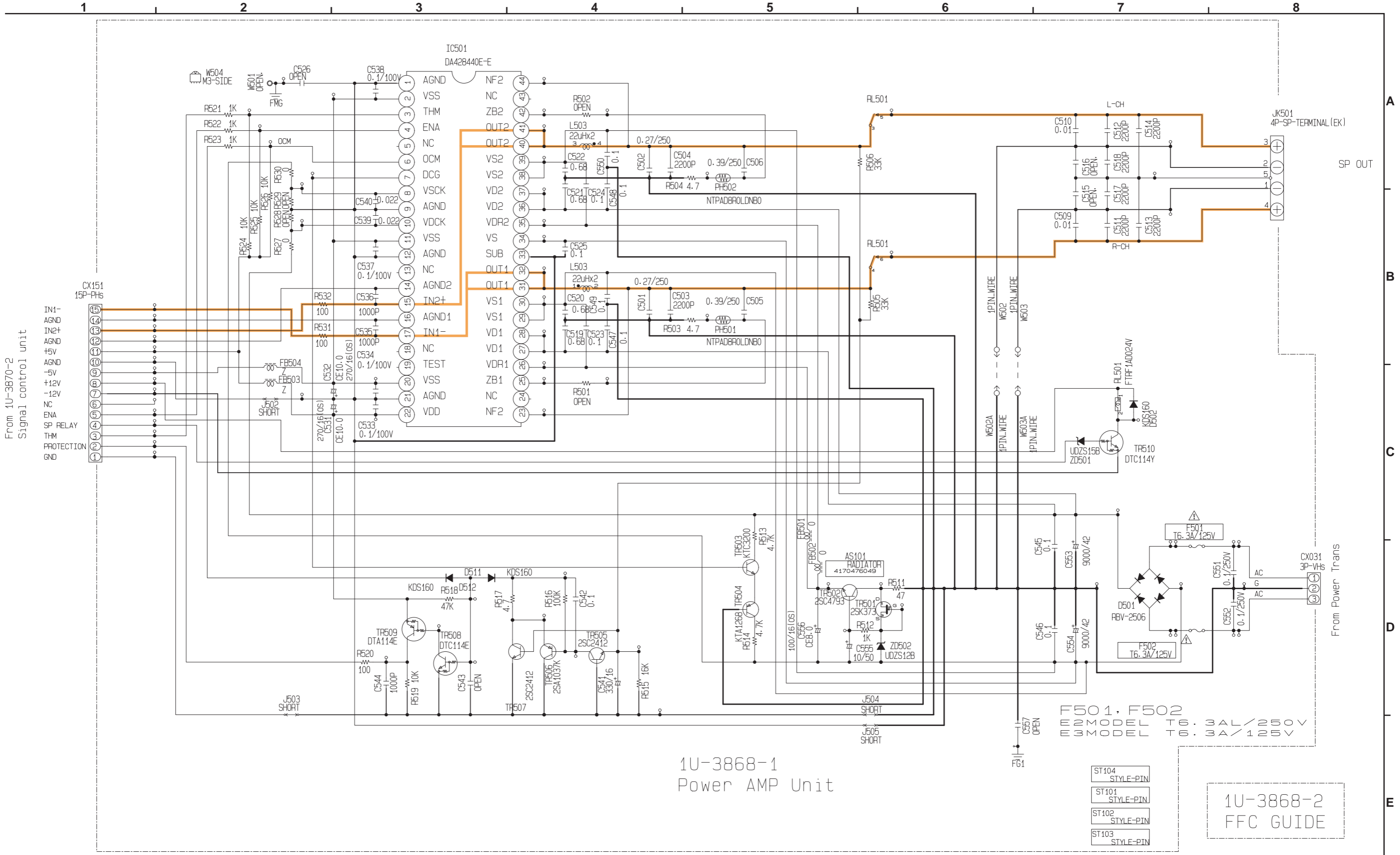

From 1U-3870-2
Signal control unit

From Power Trans

- ST104
STYLE-PIN
- ST101
STYLE-PIN
- ST102
STYLE-PIN
- ST103
STYLE-PIN

— SIGNAL LINE

SCHEMATIC DIAGRAMS (1/9)
 1U-3868-1 POWER AMP UNIT
 1U-3868-2 FFC GUIDE

POA-3012CI

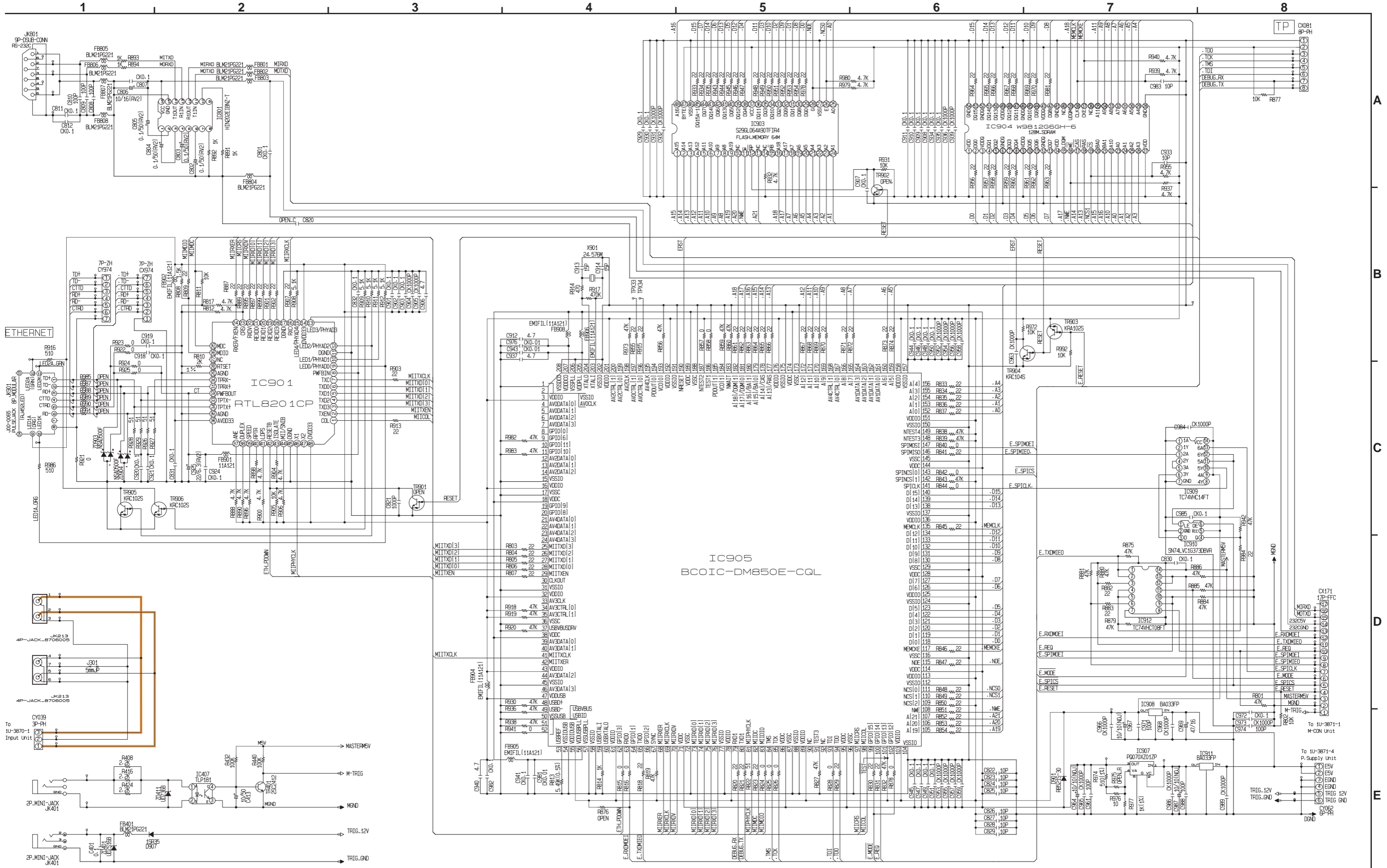

ETHERNET

To 1U-3870-1 Input Unit

To 1U-3871-1 M-CON Unit

To 1U-3871-4 P. Supply Unit

To 1U-3871-4 M-CON Unit

1U-3869-1
Communication Unit(1/2)

SIGNAL LINE

SCHEMATIC DIAGRAMS (2/9)
1U-3869-1 COMMUNICATION UNIT(1/2)

POA-3012CI

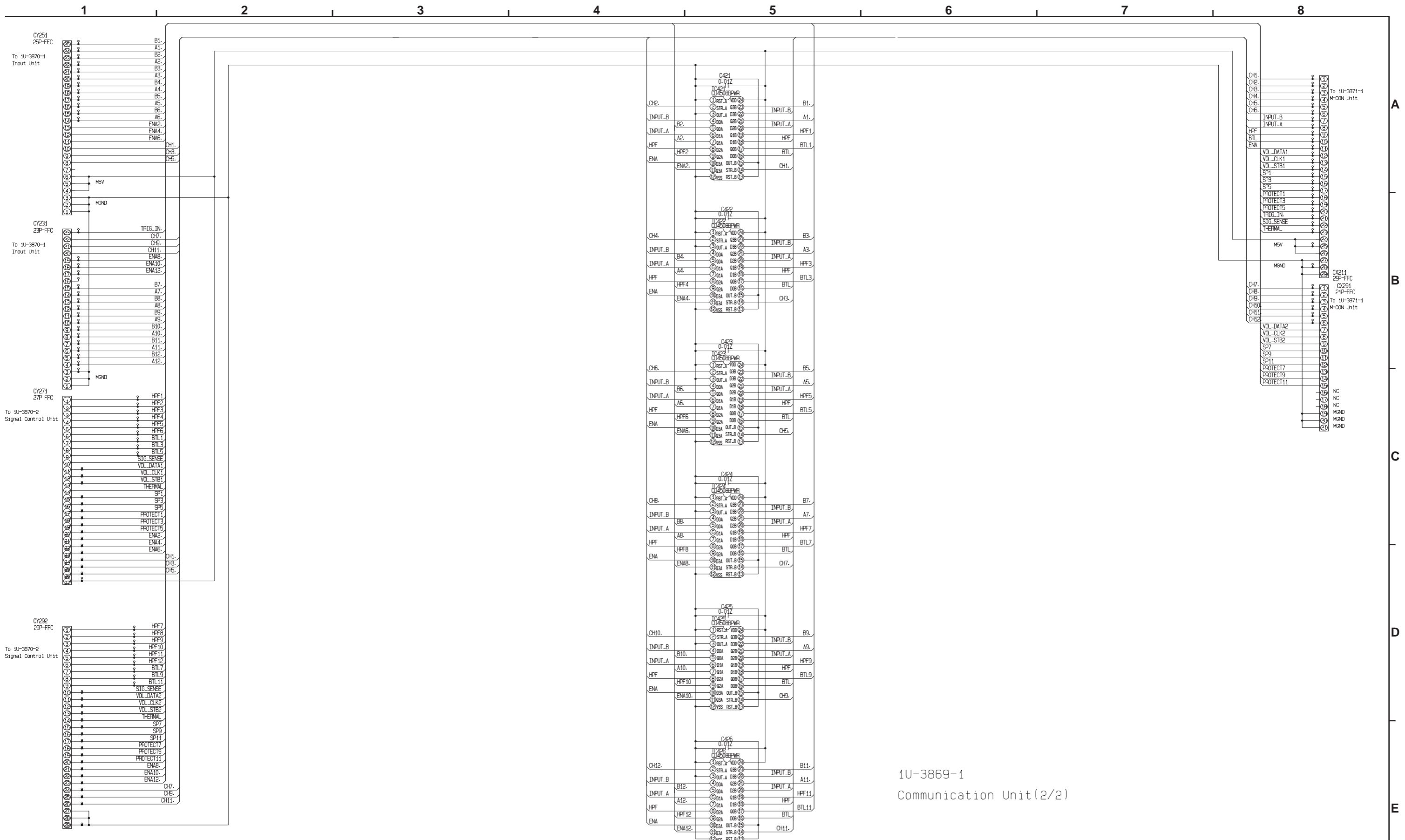

1U-3869-1
Communication Unit(2/2)

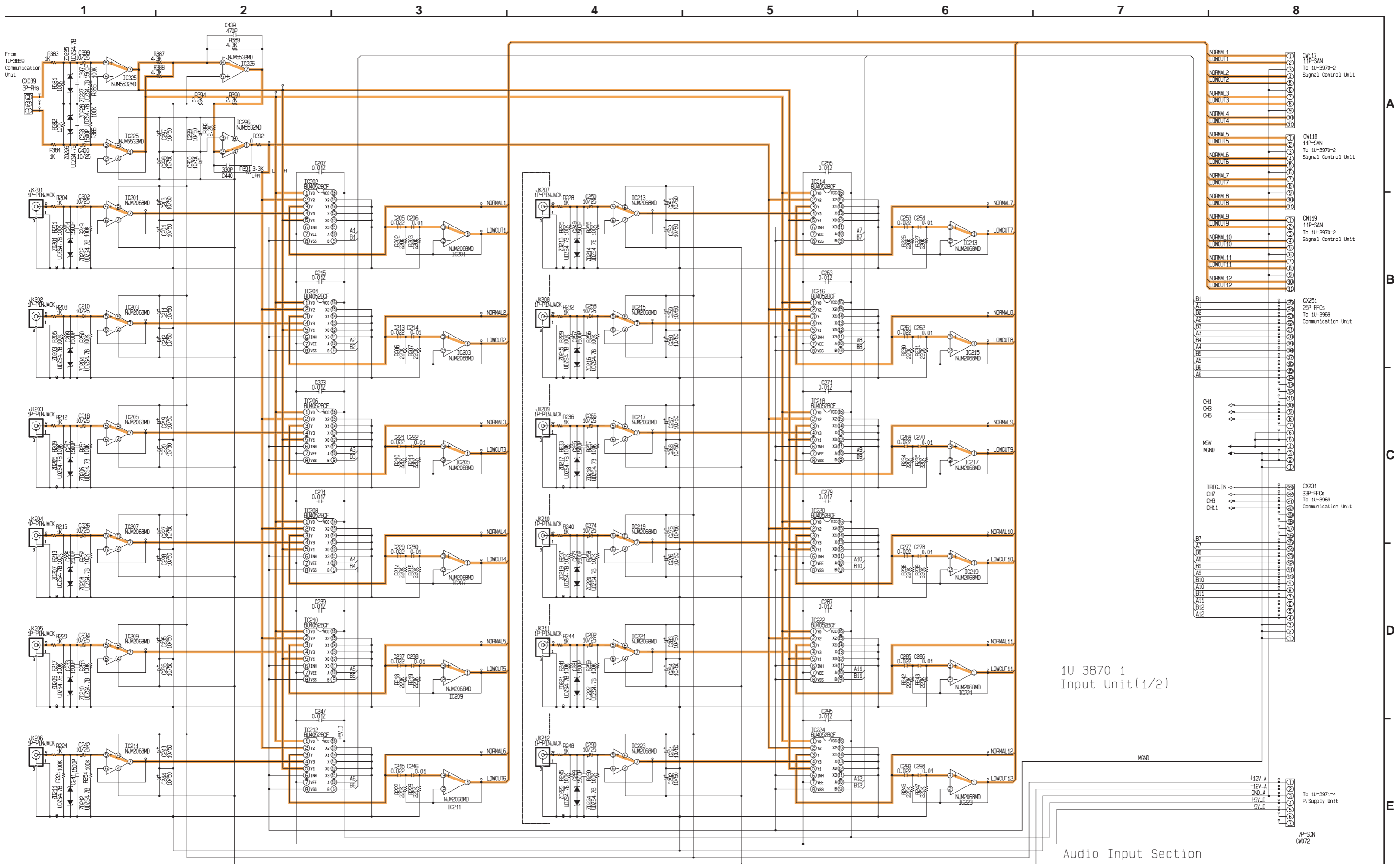

1U-3870-1
Input Unit (1/2)

Audio Input Section

— SIGNAL LINE

SCHEMATIC DIAGRAMS (4/9)
1U-3870-1 INPUT UNIT(1/2)

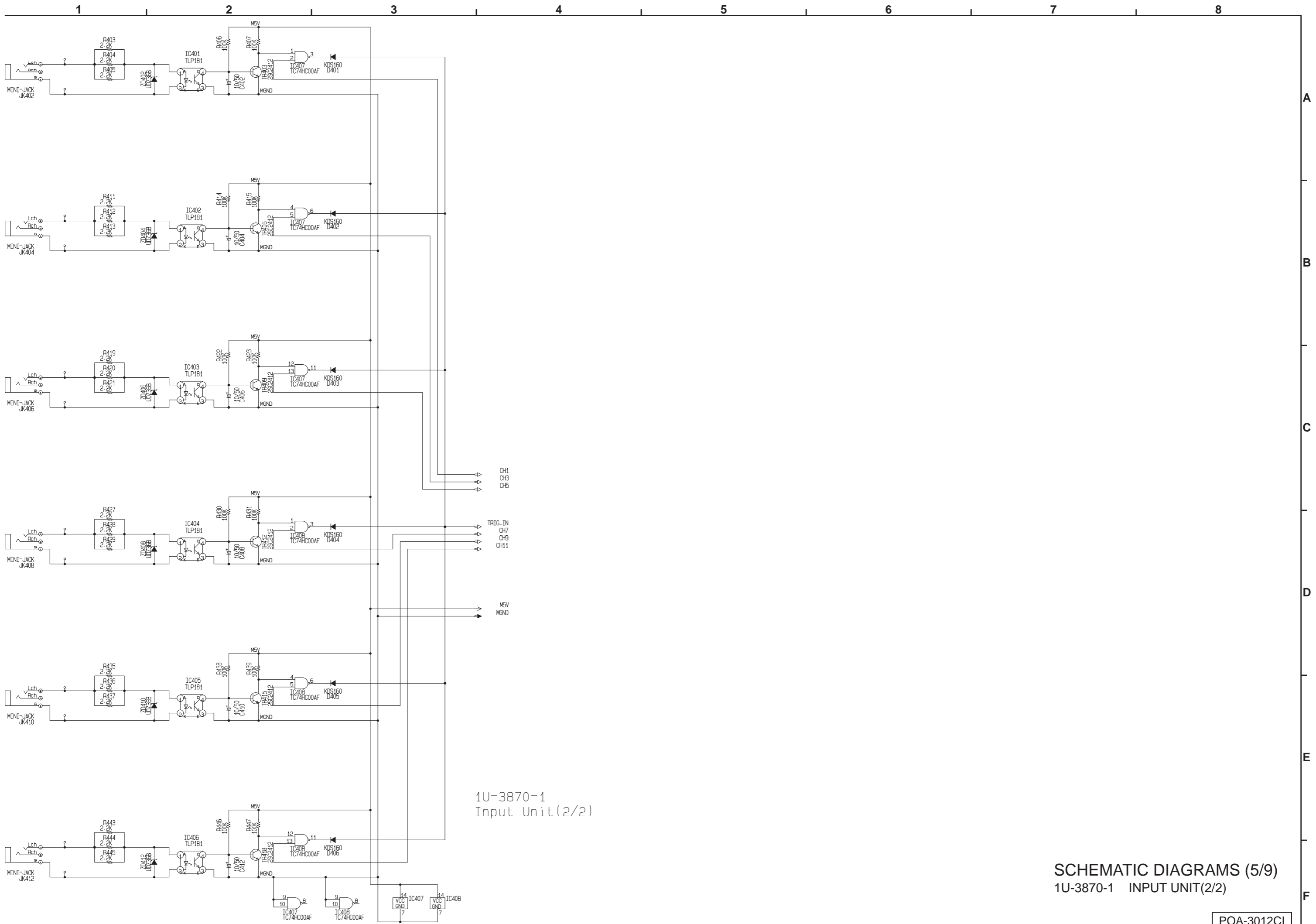

SCHEMATIC DIAGRAMS (5/9)
1U-3870-1 INPUT UNIT(2/2)

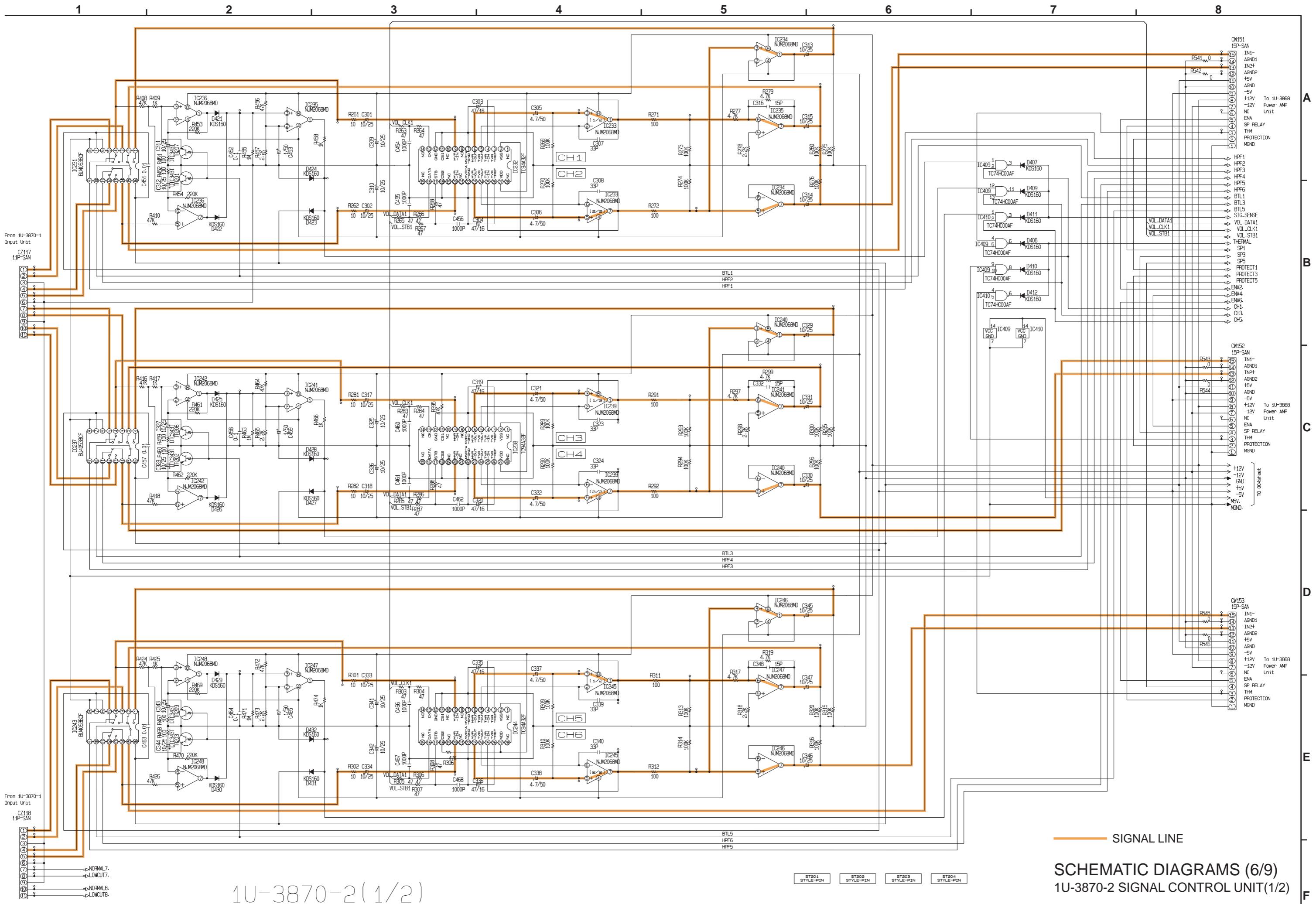

1U-3870-2(1/2)

— SIGNAL LINE

SCHEMATIC DIAGRAMS (6/9)
1U-3870-2 SIGNAL CONTROL UNIT(1/2)

POA-3012CI

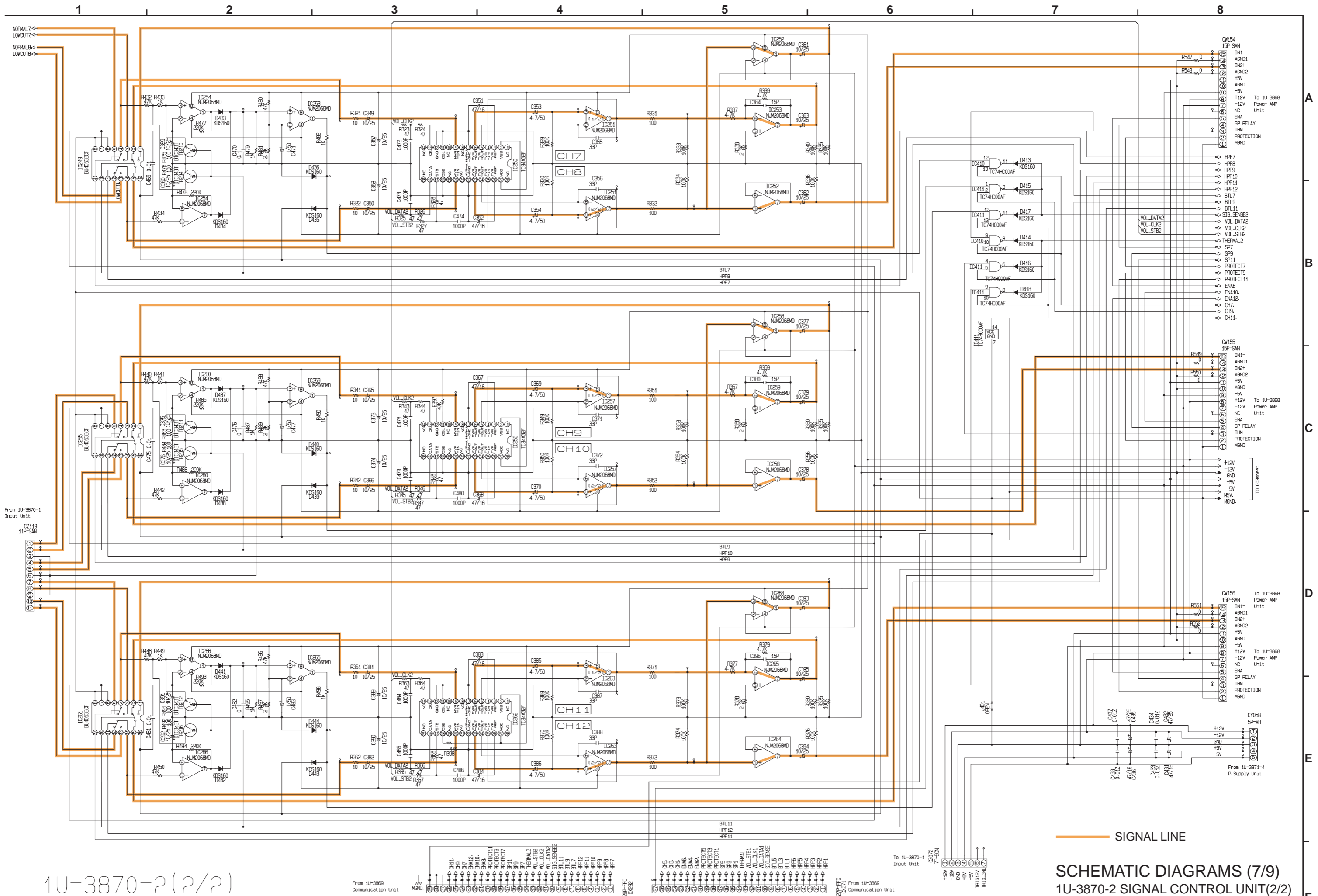

1U-3870-2(2/2)

SCHEMATIC DIAGRAMS (7/9)
1U-3870-2 SIGNAL CONTROL UNIT(2/2)

POA-3012CI

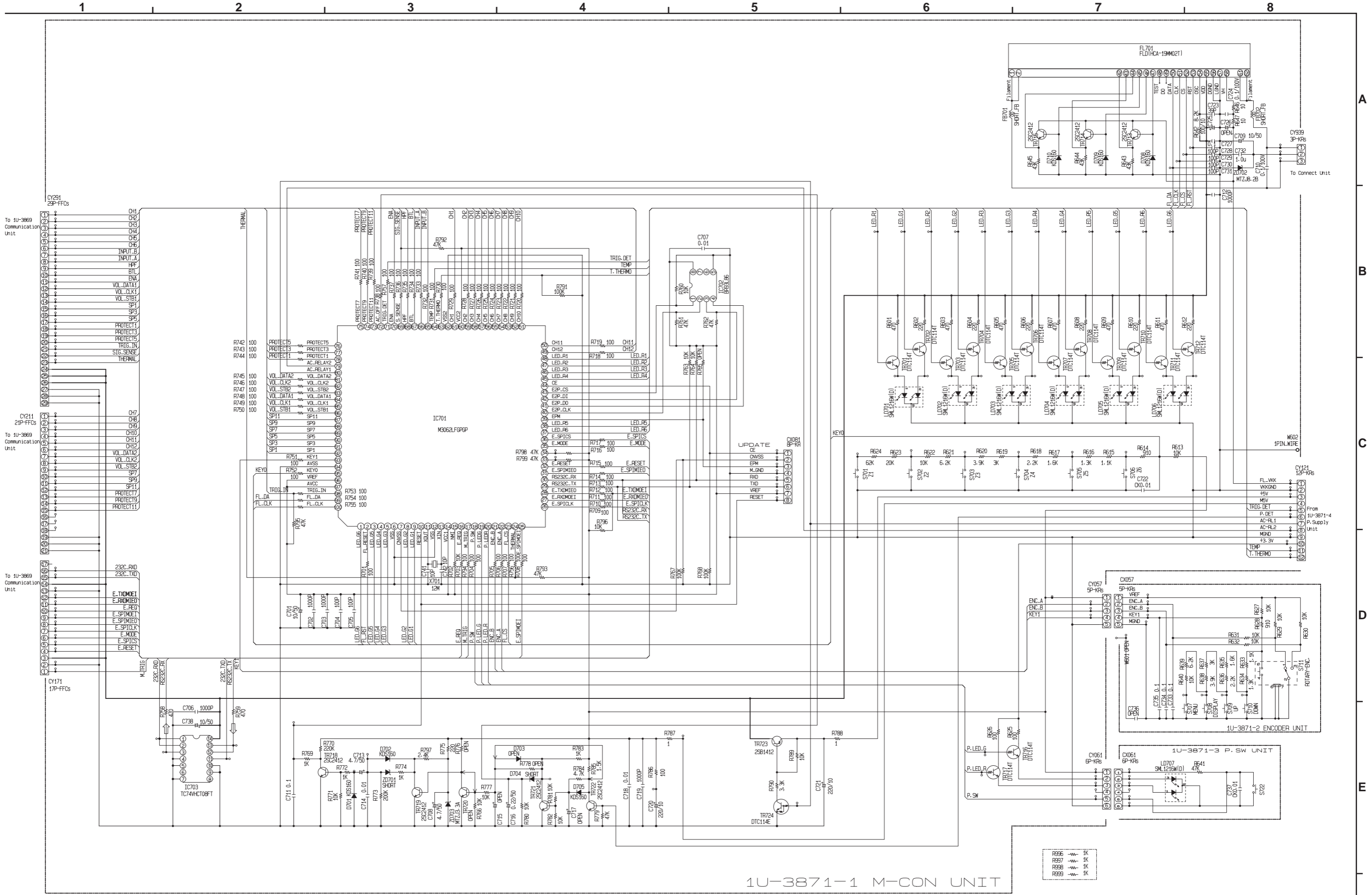

SCHEMATIC DIAGRAMS (8/9)

- 1U-3871-1 M-CON UNIT
- 1U-3871-2 ENCODER UNIT
- 1U-3871-3 P. SW UNIT

POA-3012CI

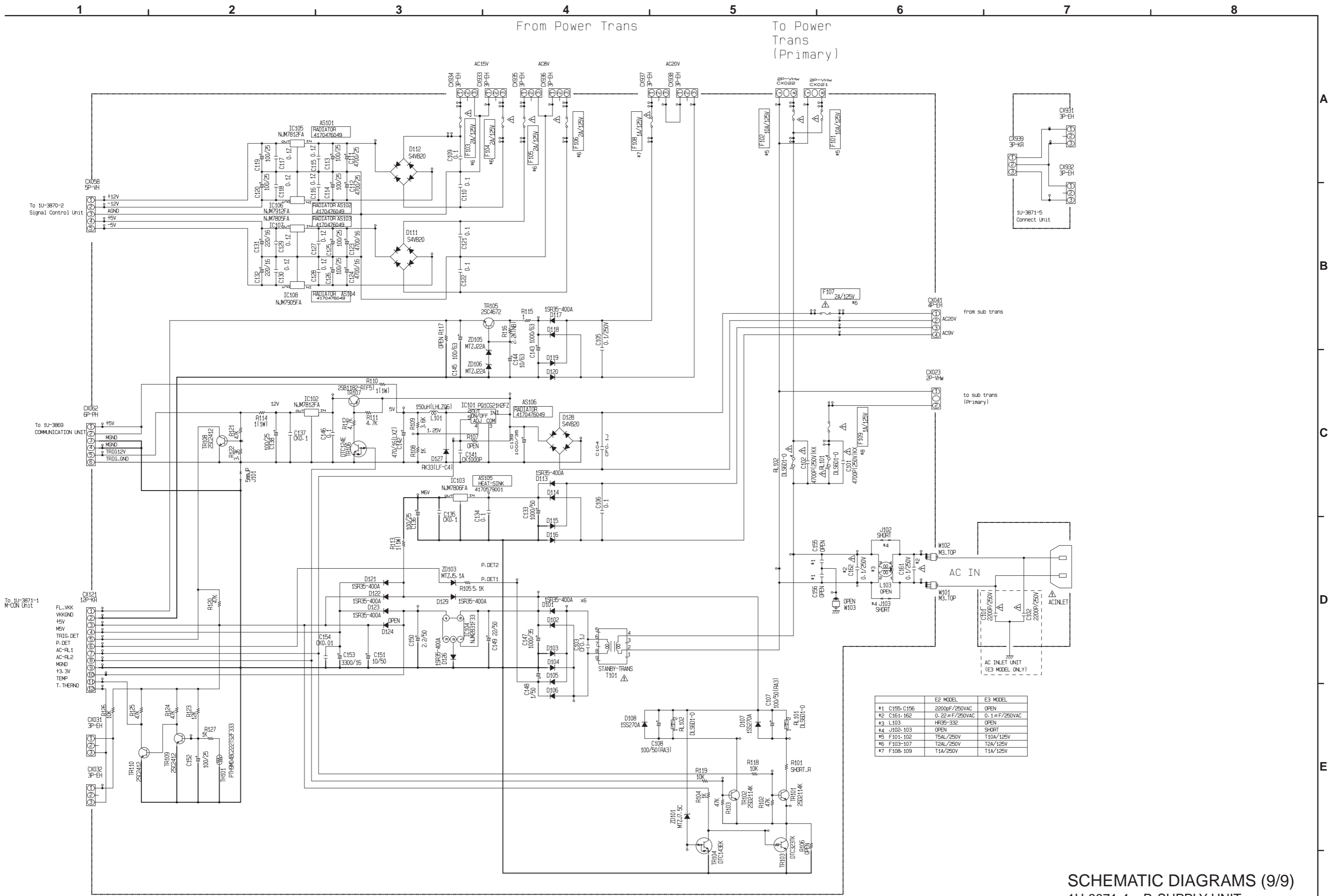

1U-3871-4 P. Supply Unit

	E2 MODEL	E3 MODEL
*1 C155- C156	2200pF/250VAC	OPEN
*2 C161- 162	0.22µF/250VAC	0.1µF/250VAC
*3 L103	H38F-332	OPEN
*4 J102- 103	OPEN	SHORT
*5 F101- 102	T54L/250V	T10A/125V
*6 F103-107	T24L/250V	T24L/125V
*7 F108- 109	T1A/250V	T1A/125V

SCHEMATIC DIAGRAMS (9/9)
 1U-3871-4 P. SUPPLY UNIT
 1U-3871-5 CONNECT UNIT