

DENON

Hi-Fi Monaural Power Amplifier

SERVICE MANUAL

MODEL POA-6600

SOLID STATE MONAURAL POWER AMPLIFIER



CONTENTS

SPECIFICATIONS	2
NAME OF EACH PART	3
CONNECTIONS	4, 5
REMOVAL OF EACH SECTION	6
METHOD OF ADJUSTMENTS	7
TROUBLESHOOTING	8
BLOCK DIAGRAM	9
SEMICONDUCTORS	9
PRINTED WIRING BOARD	
KU9117 POWER UNIT	10
KU9118 P.S. UNIT	11
PRINTED WIRING BOARD PARTS LIST	12 ~ 15
WIRING DIAGRAM	16
SCHEMATIC DIAGRAM	17
EXPLODED VIEW OF CHASSIS AND CABINET & PARTS LIST	18
ADDENDUM LIST	19

NIPPON COLUMBIA CO., LTD.

SPECIFICATIONS

Rated output power:	250 W min., RMS into 8 ohms from 20 Hz to 20 kHz with no more than 0.02% total harmonic distortion 450 W (4 ohm, DIN 1 kHz)	S/N ratio:	123 dB (IHF, A-weighting)
Dynamic power:	650 W (at 4 ohm) 1100 W (at 1 ohm)	Slew rate:	± 500 V/ μ sec
Total harmonic distortion:	Less than 0.002% (-3 dB at rated output, 8 ohm)	Output terminals:	Speakers A or B 4 ohm ~ 16 ohm A + B 8 ohm ~ 16 ohm
Intermodulation distortion:	Less than 0.002% (60 Hz/7 kHz: 4/1 at rated output, 8 ohms)	Power supply:	AC 220 V/50 Hz (for European countries) AC 240 V/50 Hz (for U.K. and Australia) AC 120 V/60 Hz (for U.S.A. and Canada) AC 110/120/220/240 V/50, 60 Hz [for Asia (Multiple)]
Power band width:	5 Hz - 80 kHz (8 ohms, THD 0.02%)	Power consumption:	7 A (for U.S.A. and Canada) 350 W (for IEC) 275 W (for Multiple)
Frequency response:	1 Hz - 300 kHz + 0, -3 dB (at 1 W)	Dimensions:	310 (W) x 207 (H) x 456 (D) mm (Including control knobs and feet)
Input sensitivity:	1 V (Normal in) 1 V (Balance in)	Weight:	15.6 kg
Input impedance:	25 k ohms (Normal in) 10 k ohms (Balance in)		
Output impedance:	0.1 ohm (1 kHz)		

* Design and specifications are subject to change without prior notice.

NOTE: The following codes correspond to the appropriate models.
E2 for Europe, EU for U.S.A., EA for Australia, EK for U.K.
E1 for Asia and EC for Canada.
This Service Manual is prepared based on EU Black Version.

NAME OF EACH PART

• FRONT PANEL

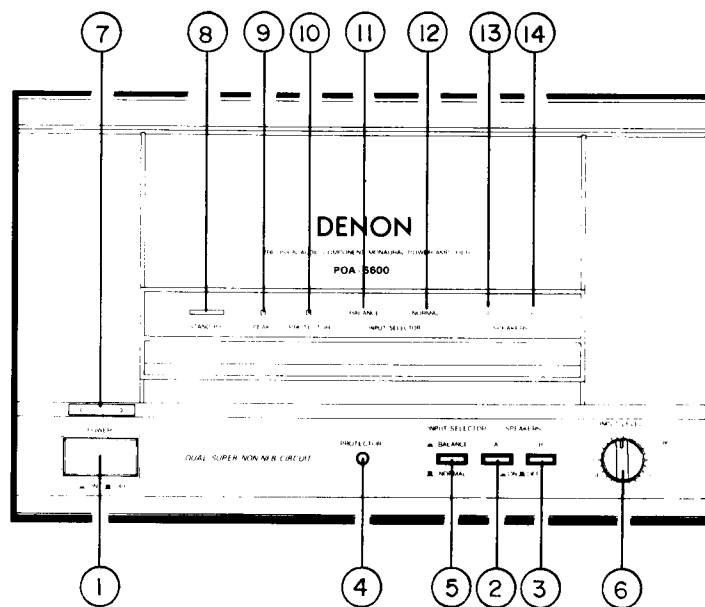

- | | | |
|--|--------------|---------------|
| ① POWER (Power Switch) | ⑧ STAND BY | } (Indicator) |
| ② SPEAKERS-A (Speaker Select Switch-A) | ⑨ PEAK | |
| ③ SPEAKERS-B (Speaker Select Switch-B) | ⑩ PROTECTOR | |
| ④ PROTECTOR (Non-locking Switch) | ⑪ BALANCE | |
| ⑤ INPUT SELECTOR (Input Selector Switch) | ⑫ NORMAL | |
| ⑥ INPUT LEVEL (Input Level Control) | ⑬ SPEAKERS-A | |
| ⑦ POWER INDICATOR | ⑭ SPEAKERS-B | |

• BACK PANEL

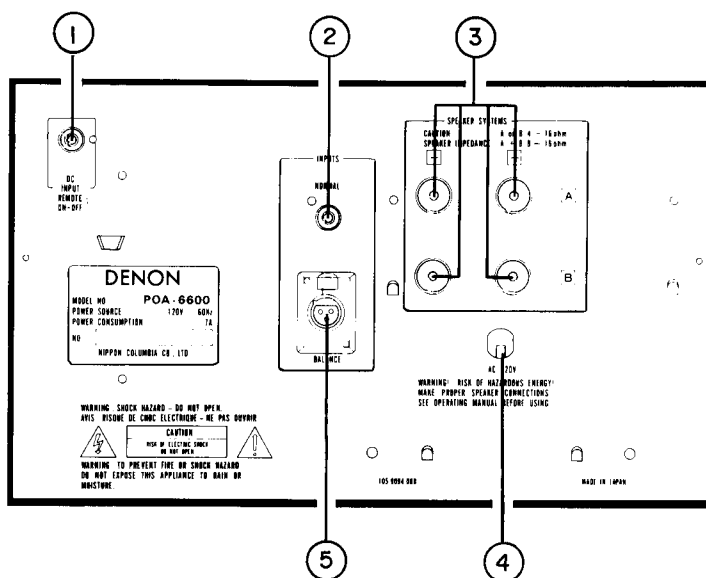

- ① DC INPUT TERMINAL
- ② NORMAL (Normal Input Jack)
- ③ SPEAKER SYSTEMS (Speaker Terminals)
- ④ AC CORD (Power Cord)
- ⑤ BALANCE

CONNECTIONS

Notes on Connection

- Do not plug the power supply cord into the wall socket, until all the connections are complete.
- Plug the pins in securely. An incomplete connection will cause noise generation.
- Binding the pin plug to the power supply cord, or setting the pin cord close to the power supply transformer will cause humming or noise, and should be avoided.

Connection to the speaker system

Connect the speaker system for the left channel (the left side as viewed facing the front) to the L speaker terminal on the back panel, and the speaker system for the right channel into the R terminal. There are two sets of **SPEAKERS** terminals. If only one speaker system is to be used, connect it to the **SYSTEM (A)** terminals.

This terminal is for the remote power switch. The power amp's power can be turned "on" and "off" by connecting the remote plug cord to the DC output terminal of the preamp (DAP-5500, etc.) and using the power switch on the preamp.

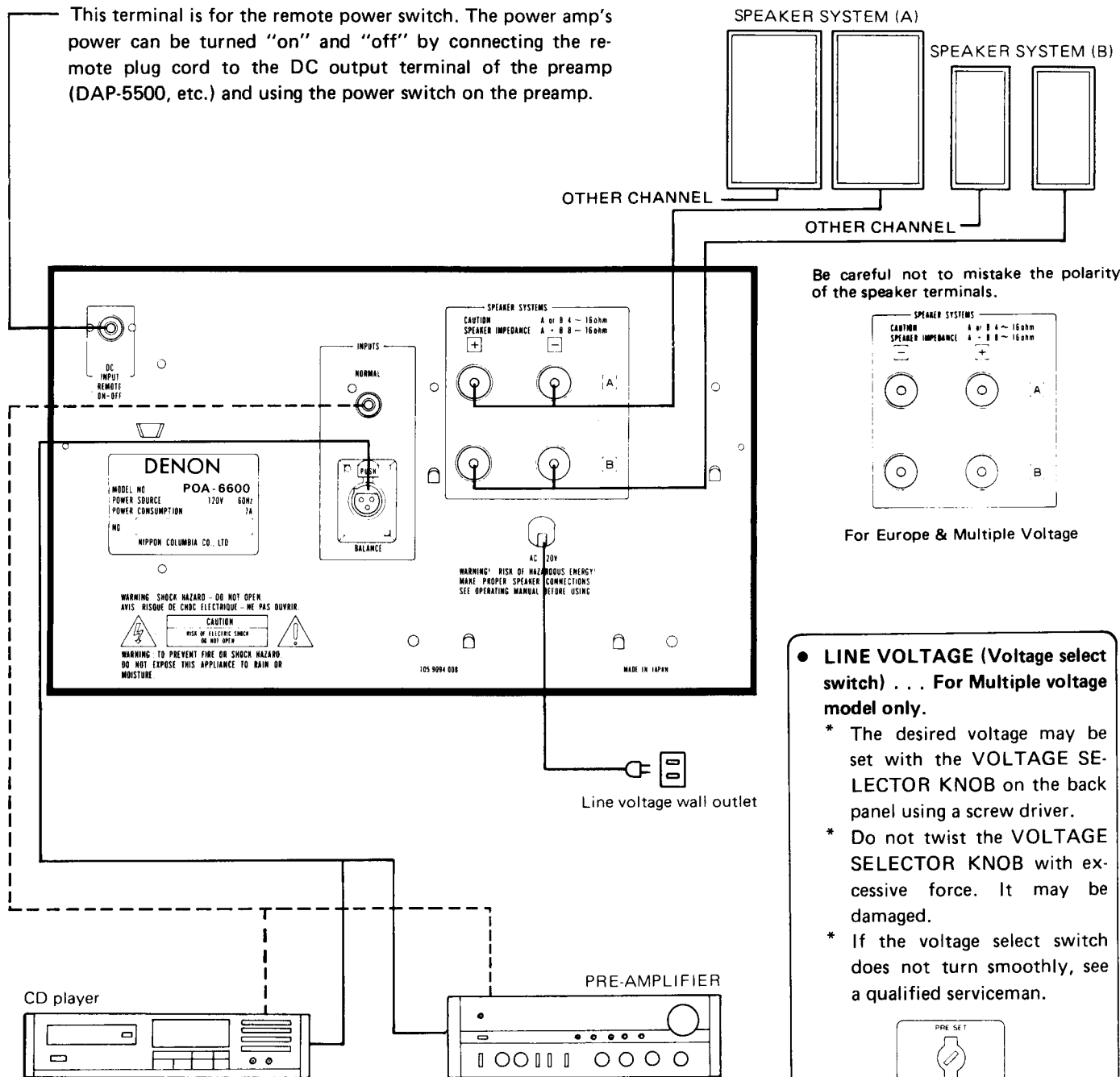

LINE VOLTAGE (Voltage select switch) . . . For Multiple voltage model only.

- The desired voltage may be set with the **VOLTAGE SELECTOR KNOB** on the back panel using a screw driver.
- Do not twist the **VOLTAGE SELECTOR KNOB** with excessive force. It may be damaged.
- If the voltage select switch does not turn smoothly, see a qualified serviceman.

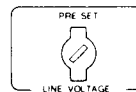

- **Connection to the speaker system**

- When connecting the speaker terminals to the speaker systems, make certain to connect the polarities correctly (+ to + and - to -). If the polarities are incorrect when the two are connected, the center area of the sound will be lacking, the positions of the musical instruments will not be clear, and the stereo directional sensitivity will be impaired.
- During connection, be careful that the center wires in the speaker cords do not protrude from the terminals to contact any other terminal, and that the central wires in the separate speaker cords do not contact each other.

- **Speaker impedance**

- When the A and B terminal sets are to be used separately, the speakers that are to be connected should have a nominal impedance of 4 to 16 ohm.
- When the two sets (A + B) are to be used at the same time, use of speakers whose impedance is outside the range from 8 to 16 ohm will result in malfunction. Be careful not to let this happen.
- Speakers with a lower impedance may cause the protective circuitry to operate.

Models for the U.S.A. and Canada only. (Case of UL standardized articles)
WARNING!

This amplifier produces a large power output at the speaker terminals, which means that a dangerous amount of energy is generated and that there is the danger of electric shock. Please perform the speaker cord connections correctly as follows.

(Making connections that differ from the specified method may give rise to a shock hazard.)

- 1) For the speaker connection cord, use a cord made with non-combustible insulation material with a VW-1 rating or a cord of the SPT-1 type or one with higher flexibility.
- 2) Use a screwdriver to take the screws holding the speaker terminal cover out.
- 3) Connect the speaker cord specified in 1) to the speaker terminals.
- 4) Tie the speaker cord, then pass it through the cutout hole in the speaker terminal cover.
- 5) Install the speaker terminal cover removed in 2).

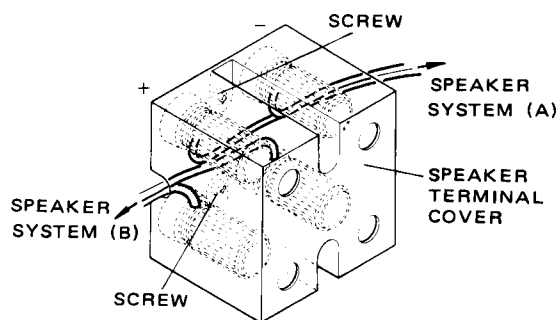
Models for destinations other than the U.S.A. and Canada.

- **For regular cords**

1. Remove the insulation from the end of each cord.
2. Twist the center wire.
3. Turn the speaker terminal to loosen it, insert the center wire of the cord, and then tighten the terminal to hold the wire in place.

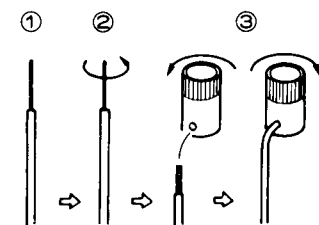

- **For extra-large cords**

1. Remove the insulation from the end of the cord. Loosen and remove the end of the speaker terminal.
2. Insert the center wire, and bend back the wire.
3. Insert the cord in the terminal, and turn the terminal to the right to tighten it.

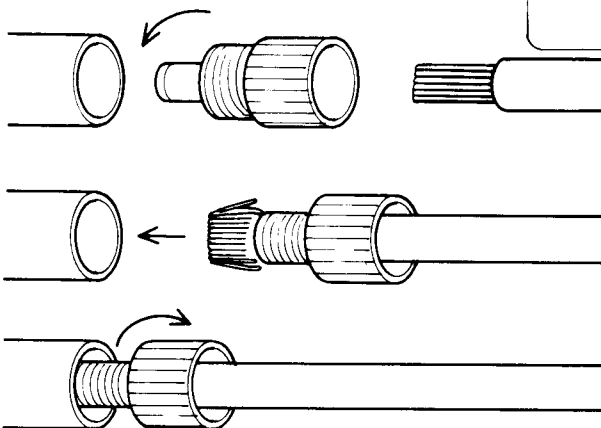

Note:

The knob on this speaker terminal can be removed from the Amplifier. Be careful not to lose these knobs, or mix up the left and right sides or polarities. Follow the indication provided on the back panel for proper handling.

REMOVAL OF EACH SECTION

1. Top Cover

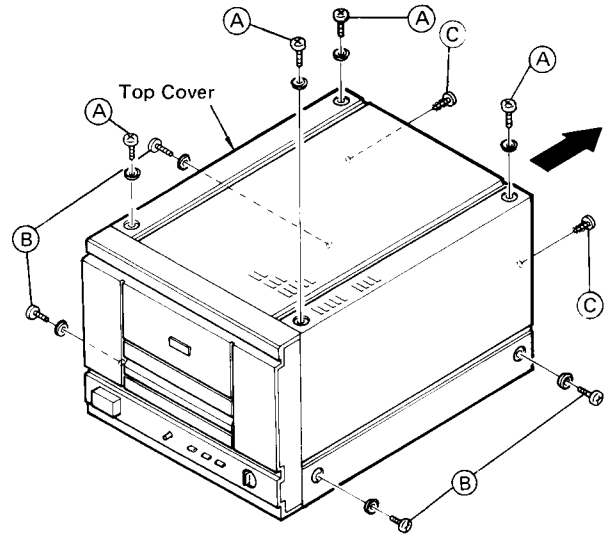
Remove 4 screws with washers (A) from the both side, 4 screws with washers (B) from left and right side and 2 screws (C) from the backside and detach the top cover in the direction arrow shows.



2. Front Panel

- 1) Pull out the Power Knob picking up by hand. (As the power switch is easily broken).
- 2) Unfasten 2 screws from the bottom, 3 screws from the top, and dismantle the Front Panel in the direction arrow shows.

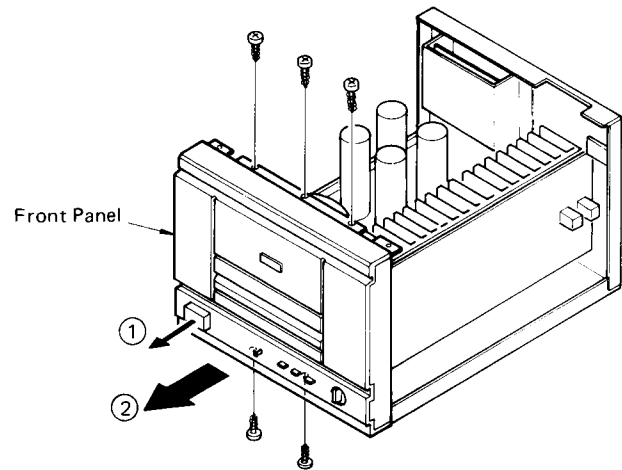

3. Back Panel

Remove 8 screws from the bottom, and take out the Bottom Cover. Then remove 4 screws from the back panel, and detach the Back Panel out of the 3 notches in the direction as arrow shows.

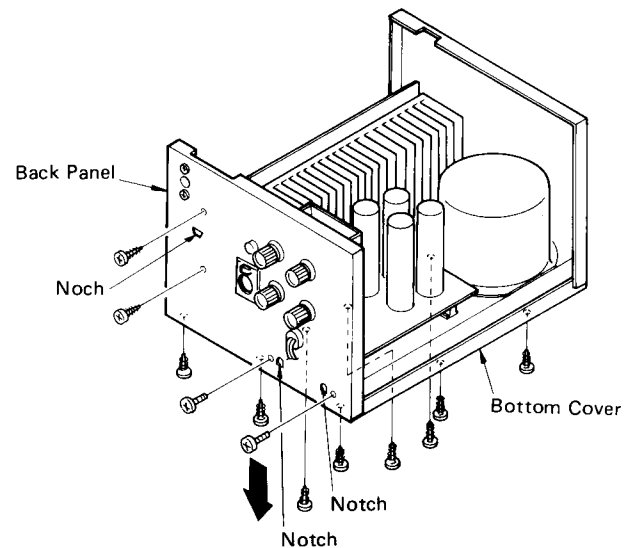

METHOD OF ADJUSTMENTS

1. Adjustment of Idle Current (KU9117-1)

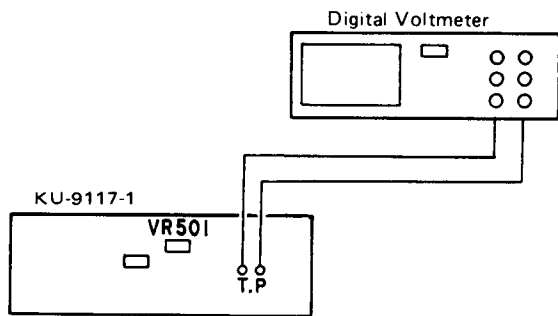

- (1) Connect a digital voltmeter to the test point.
- (2) Turn the unit power on.
- (3) Wait 2 ~ 3 minutes for warm-up, rotate VR501 and adjust voltage value on the meter to $8\text{ mV} \pm 1\text{ mV}$.

2. Adjustment of Neutral Point Voltage

- (1) Connect a digital voltmeter to the SPEAKER terminal.
- (2) Turn the unit power on.
- (3) Turn the LEVEL controls on the back panel fully clockwise (maximum).
- (4) Confirm the voltage on the meter indicates within $\pm 100\text{ mV}$ value.

3. Adjustment of Distortion Factor (KU-9117-1)

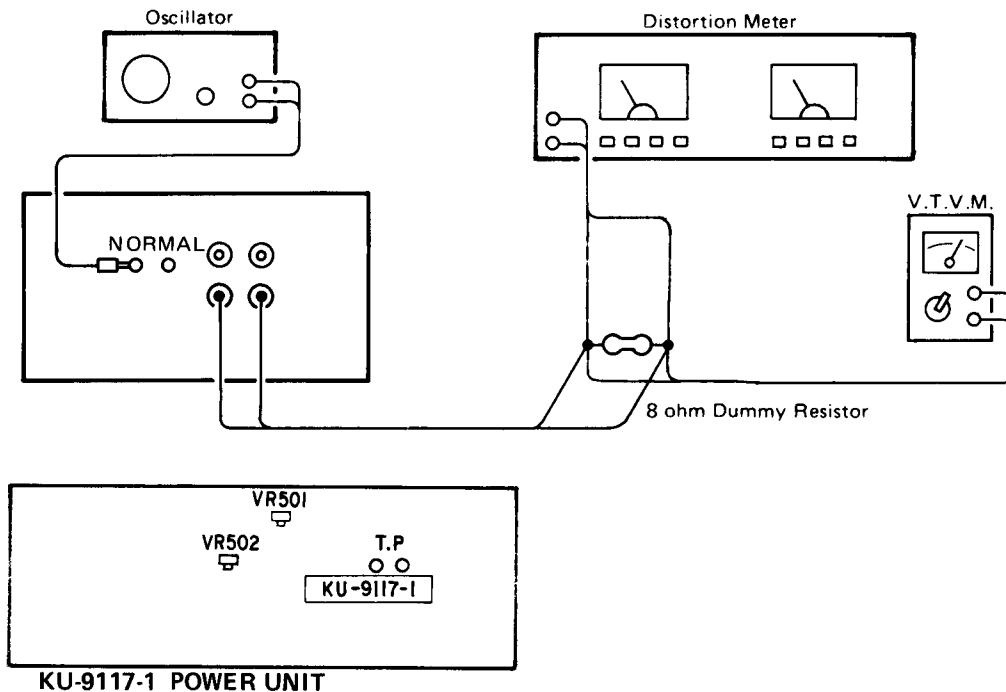

- (1) Set an oscillator output to "NORMAL" and feed it.

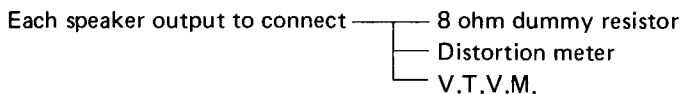

- (2) Turn the unit power on, and set the LEVEL controls to maximum.
- (3) In the first place confirm that there's no dropping of supply voltage, then set the oscillator frequency to 20 kHz and adjust output of oscillator to obtain 31.6V for speaker output.
- (4) Adjust VR502 on the KU-9117-1 for minimum distortion. Distortion factor must be no more than 0.005% at this time.

TROUBLESHOOTING

Before troubleshooting, be sure to check whether your audio system is really the source of the problem.

If you think the amplifier is out of order, first check the following one more time:

1. Are all the connections correctly made?
2. Is the set being operated properly in accordance with the Operating Manual?
3. Are the speakers and preamplifier being operated correctly?

If the set does not operate properly, perform the checks indicated in the flow chart below.

If none of the items listed apply to the difficulty, the amplifier is probably out of order. Turn off the power immediately, and contact the outlet where you purchased the amplifier or your nearest DENON dealer.

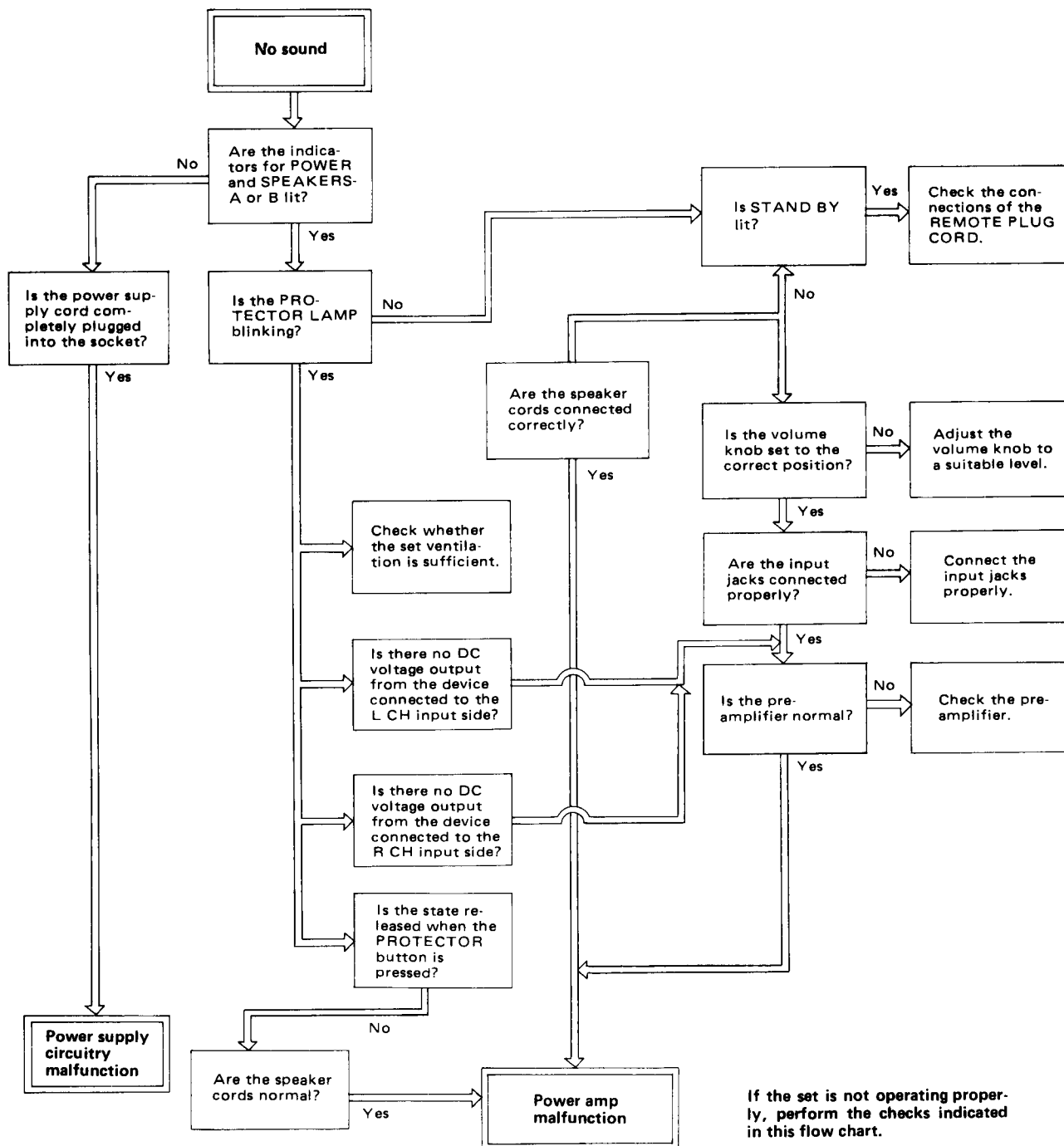

If the set is not operating properly, perform the checks indicated in this flow chart.

BLOCK DIAGRAM

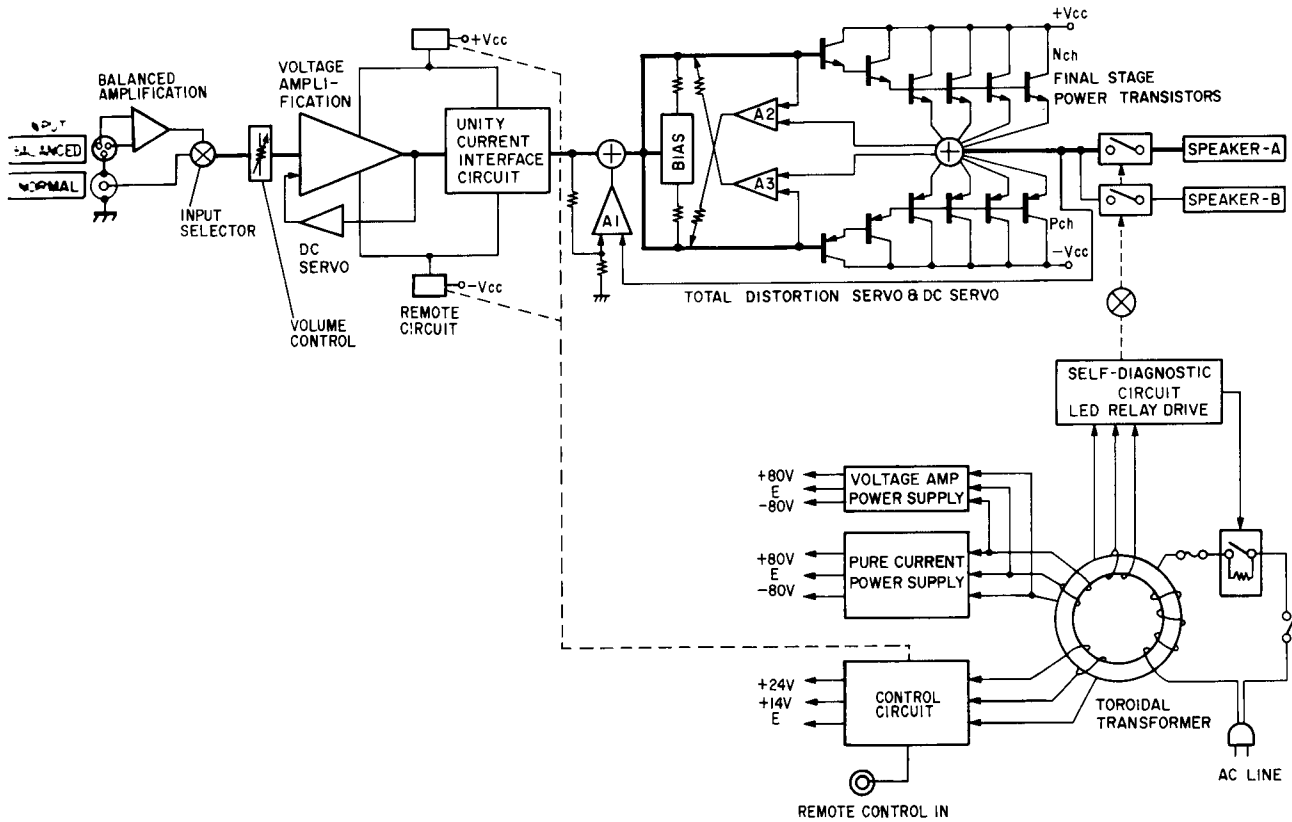

SEMICONDUCTORS

• IC

NJM-2068DA (JRC)
 NJM-082DT/BD (JRC)
 M-5218P (Mitsubishi)

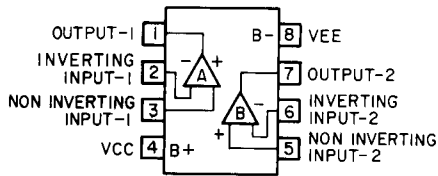
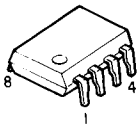

HD14001BP
 (Hitachi)

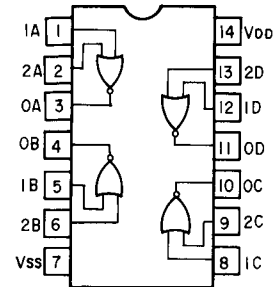
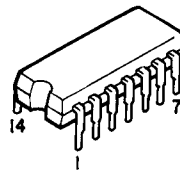

• Transistor

2SC2238B (Y)
 2SA968B (Y)

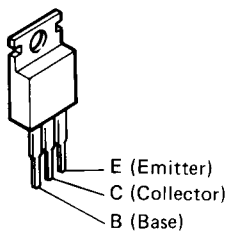

2SC3852

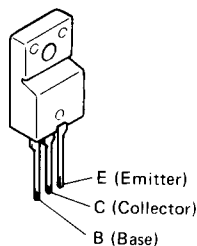

2SA1492LB(O/P/Y)
 2SC3856LB(O/P/Y)

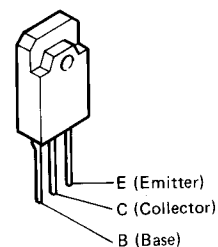

2SC1815 (BL)
2SC2878 (A/B)
2SA988 (E/F)

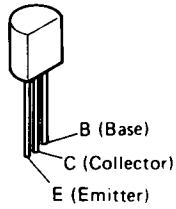

2SC2705(O/Y)
2SC3334
2SA1321

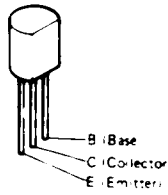

2SC2458(BL)

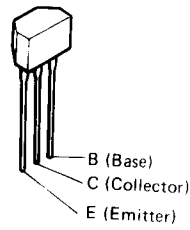

2SK184C(Y/GR/BL)

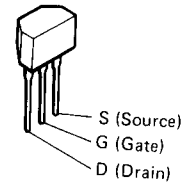

RN1202 (10K-10K)NPN
RN2202 (10K-10K)PNP

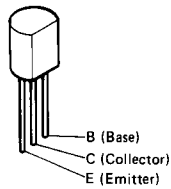

RN1202

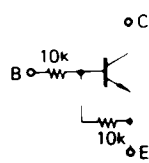

RN2202

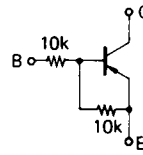

•Diode

1SS270A

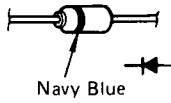

1S2076A

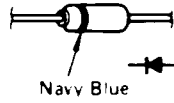

HZ-5C-1
HZ7B-3
HZ9B-2
HZ15-2

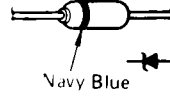

RM-4Y-LF-J1

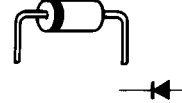

DSA1A2(Type-3)

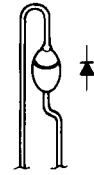

PTH487A01BD222TS

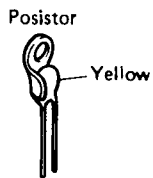

MV-1YH

Indication of cathode, white

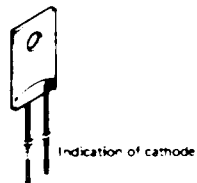

SLF-406
SLF-206B

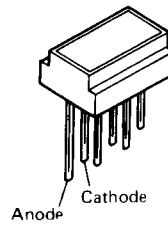

1D4B41

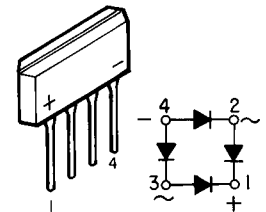

4D4B42(LCI)

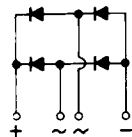
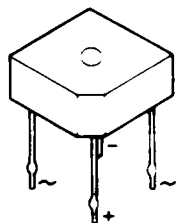

SEL-4910A
SEL-4110S

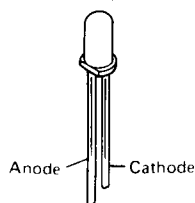

SFOR1A42
Thyristor

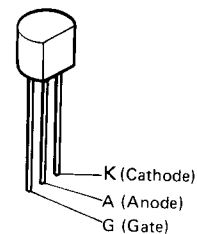

PRINTED WIRING BOARD

KU9117 POWER UNIT

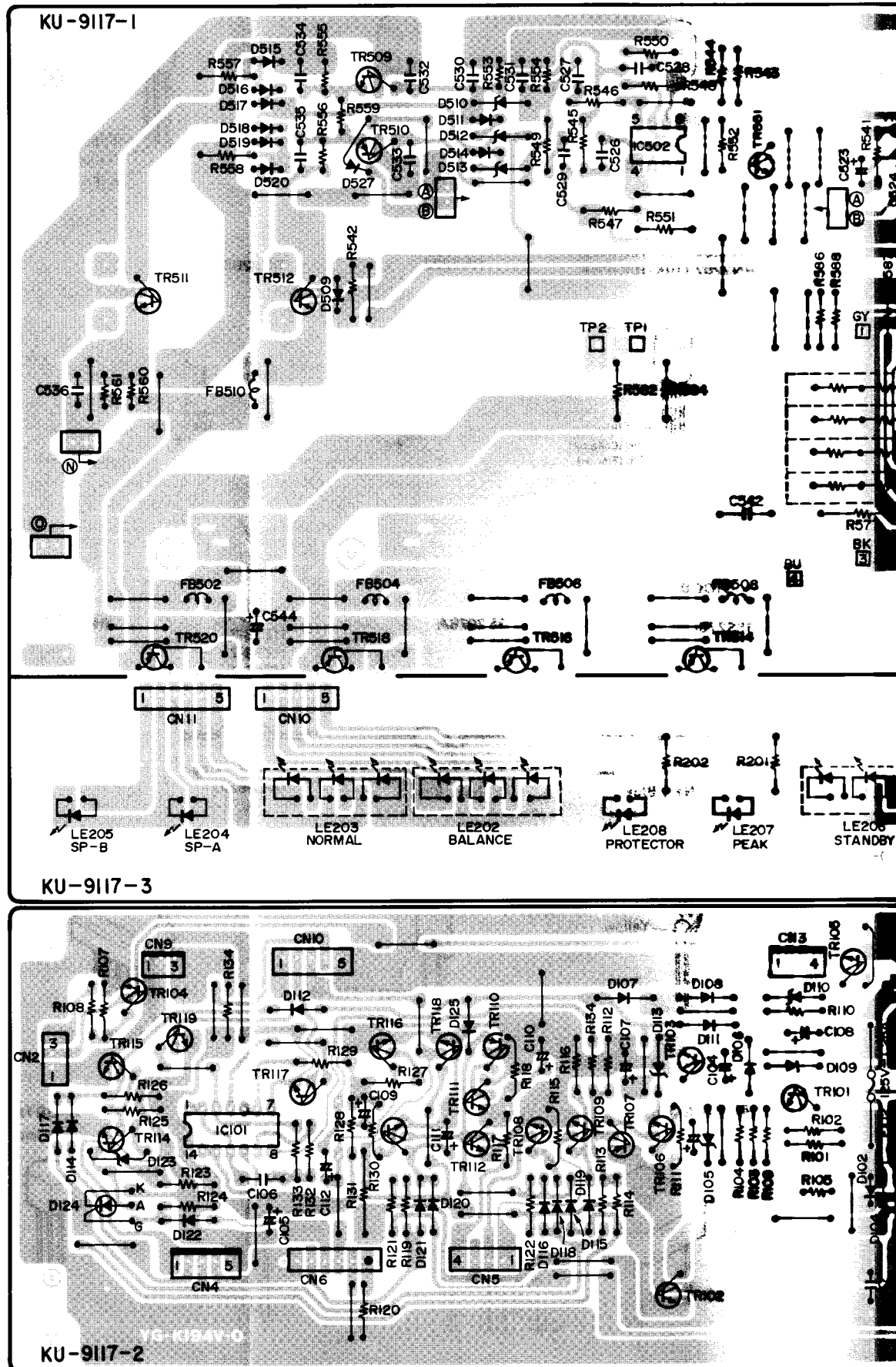

KU9118 P.S. UNIT

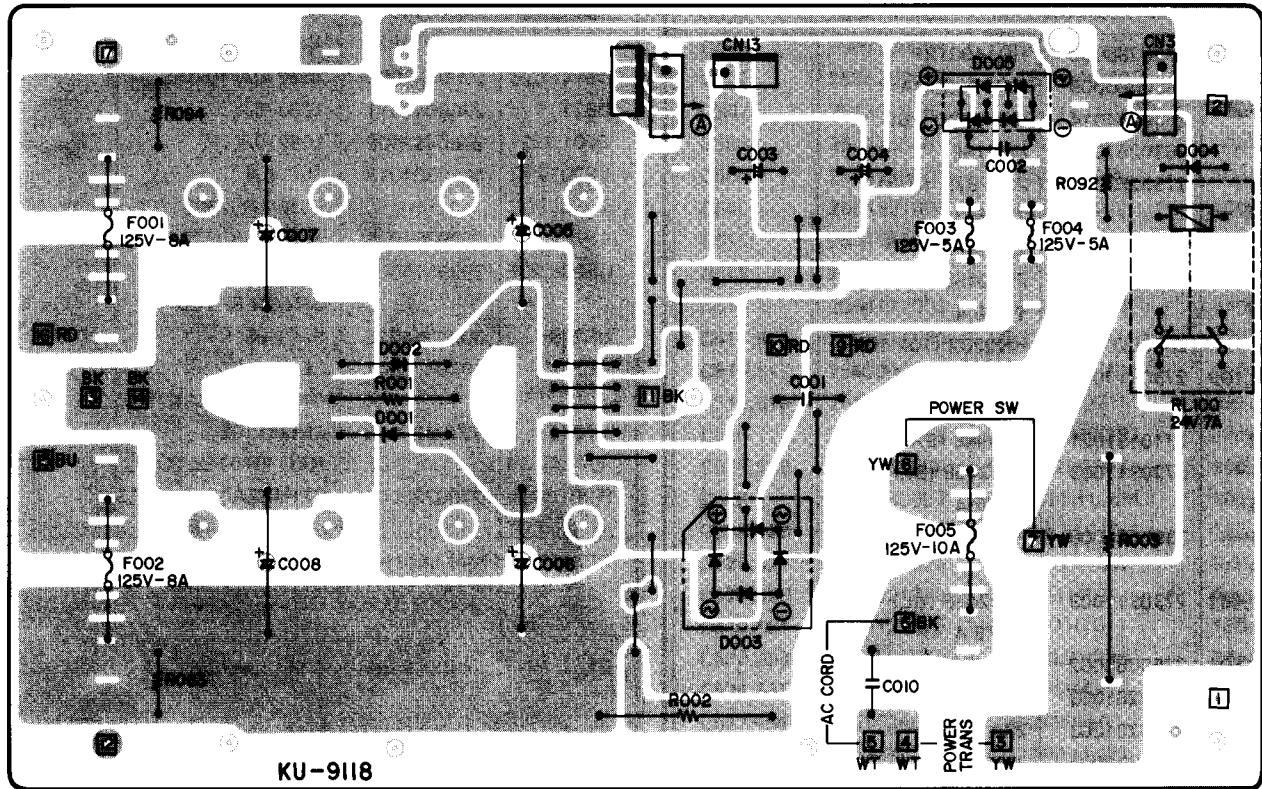

PRINTED WIRING BOARD PARTS LIST

KU9117 POWER PARTS LIST

Ref. No.	Part No.	Part Name	Remarks
SEMICONDUCTORS GROUP			
IC101	2620298009	HD14001BP	
IC401	2630466009	NJM-2068DA	
IC501	2630244014	NJM082DT/BD	
IC502	2630257001	M5218P	
TR101	2730253015	2SC2878 (A/B) TYPE 2	
TR102	2730330006	2SC3852	
TR103~ 106	2730317003	2SC2458 (BL) TYPE 4	
TR107	2690026007	RN2202 (10k-10k)	
TR108,109	2730317003	2SC2458 (BL) TYPE 4	
TR110	2710131021	2SA988 (E/F)	
TR111~ 115	2730317003	2SC2458 (BL) TYPE 4	
TR116~ 119	2690025008	RN1202 (10k-10k)	
TR451,452	2730317003	2SC2458 (BL) TYPE 4	
TR500,501	2750055002	2SK184C (Y/GR/BL)	
TR502,503	2730281003	2SC2705 (O/Y)	
TR504,505	2710201003	2SA1321	
TR506,507	2730332004	2SC3334	
TR508	2710201003	2SA1321	
TR509	2730332004	2SC3334	
TR510	2710201003	2SA1321	
TR511	2730259006	2SC2238B (Y)	
TR512	2710151001	2SA968B (Y)	
TR521	2710131021	2SA988 (E/F)	
TR522	2730332004	2SC3334	
TR523	2710201003	2SA1321	
TR524	2710131021	2SA988 (E/F)	
TR525	2730332004	2SC3334	
TR551	2730198015	2SC1815 (BL)	
D101,102	2760427015	DSA1A2 (TYPE-3)	
D103,104	2760049011	1S2076A	
D105	2760253011	HZ15-2	
D106~109	2760049011	1S2076A	
D110	2760236031	HZ5C-1	
D111,112	2760049011	1S2076A	
D113	2760254000	HZ7B-3	
D114~122	2760049011	1S2076A	
D123	2760218033	HZ9B-2	
D124	2790016001	SF0R1A42	
D126~128	2760049011	1S2076A	
D501,502	2760253001	HZ15-2	
D503~505	2760432000	1SS270A	
D506,507	2760253001	HZ15-2	
D508	2760432000	1SS270A	
D509	2760388002	MV-1 YH	
D510	2760236031	HZ5C-1	
D511	2760432000	1SS270A	

Ref. No.	Part No.	Part Name	Remarks
D512,513	2760254000 2760236031	HZ7B-3 HZ-5C-1	for E2
D514~526	2760432000	1SS270A	
D527	2760049011	1S2076A	
D701,702	2760432000	1SS270A	
LE201	3939364018	SLF-406 (POWER LED)	
LE202,203	3939364005	SLF-206B	
LE204,205	3939375007	SEL-4910A GREEN SP A/B	
LE206	3939364018	SLF-406	
LE207	3939375007	SEL-4910A ORANGE PEAK	
LE208	3939373009	SEL-4110S RED PROTECTOR	
P-001	2760289004	PTH487A01BD222TS	

RESISTORS (not included Carbon Film $\pm 5\%$, 1/4W type)

▲ R108	2412387908	RD14B2E010JNBST	1 Ω , 1/4W, $\pm 5\%$
▲ R131	2440042024	RS14B3A122JNBF	1.2k Ω , 1W, $\pm 5\%$
▲ R453	2440035028	RS14B3A331JNBF	330 Ω , 1W, $\pm 5\%$
▲ R505,506	2412389983	RD14B2E222JNBST	2.2k Ω , 1/4W, $\pm 5\%$
▲ R507	2412378917	RD14B2E201JNBST	200 Ω , 1/4W, $\pm 5\%$
▲ R515,516	2412378904	RD14B2E181JNBST	180 Ω , 1/4W, $\pm 5\%$
▲ R518	2412379981	RD14B2E821JNBST	820 Ω , 1/4W, $\pm 5\%$
▲ R520	2412377947	RD14B2E101JNBST	100 Ω , 1/4W, $\pm 5\%$
▲ R523	2412377947	RD14B2E101JNBST	100 Ω , 1/4W, $\pm 5\%$
▲ R525,526	2412375981	RD14B2E220JNBST	22 Ω , 1/4W, $\pm 5\%$
▲ R527,528	2412387908	RD14B2E010JNBST	1 Ω , 1/4W, $\pm 5\%$
▲ R529~532	2440044022	RS14B3A162JNBF	1.8k Ω , 1W, $\pm 5\%$
▲ R534	2412377947	RD14B2E101JNBST	100 Ω , 1/4W, $\pm 5\%$
▲ R536	2412379987	RD14B2E102JNBST	1k Ω , 1/4W, $\pm 5\%$
▲ R537~540	2412381946	RD14B2E472JNBST	4.7k Ω , 1/4W, $\pm 5\%$
▲ R553,554	2412379987	RD14B2E102JNBST	1k Ω , 1/4W, $\pm 5\%$
▲ R555,556	2412377947	RD14B2E101JNBST	100 Ω , 1/4W, $\pm 5\%$
▲ R524	2442044020	RS14B3A101JNBST	100 Ω , 1W, $\pm 5\%$ (UL Model)

Ref. No.	Part No.	Part Name	Remarks
▲R569	2412379903	RD14B2E471JNBST	470Ω, %W, ±5%
▲R560	2412377947	RD14B2E101JNBST	100Ω, %W, ±5%
▲R562,563	2412378964	RD14B2E470JNBST	47Ω, %W, ±5%
R564~567	2432033038	RW---3DR18R18	0.18Ω×2, 2W
▲R568	2412377934	RD14B2E910JNBST	91Ω, %W, ±5%
▲R573	2412370038	RD14B2E392JNB	3.9kΩ, %W, ±5%
▲R575,576	2440052027	RS14B3A822JNB	8.2kΩ, 1W, ±5%
▲R577	2440021029	RS14B3A220JNB	22Ω, 1W, ±5%
▲R578	2412379945	RD14B2E681JNBST	680Ω, %W, ±5%
▲R591,592	2440106025	RS14B3D472JNB	4.7kΩ, 2W, ±5%
▲R593	2412378804	RD14B2E181JNBST	180Ω, %W, ±5%
▲R594	2412379945	RD14B2E681JNBST	680Ω, %W, ±5%
▲R601~603	2412387940	RD14B2E4R7JNBST	4.7Ω, %W, ±5%
▲R704	2440025025	RS14B3A470JNB	47Ω, 1W, ±5%
VR401	2119053001	V16V35FB503	50kΩ
VR501	2116014072	V09QB103	10kΩ, } semi-fixed
VR502	2116014069	V09QB201	200Ω, } resistor

CAPACITORS GROUP

▲C009	2538003014	CK45E2SAD472M	0.0047μF/400V AC
C101	2554079048	CQ93P2A103J	0.01μF/100V
C102	2544258099	CE04W1V102M	1000μF/35V
C103	2544260032	CE04W1HR47M	0.47μF/50V
C104	2544258057	CE04W1V101M	100μF/35V
C105	2544260045	CE04W1H010M	1μF/50V
C106	2561035017	CF93A1H224J	0.22μF/50V
C107	2544254022	CE04W1C330M	33μF/16V
C108	2544250039	CE04W0J221M	220μF/6.3V
C109	2544258002	CE04W1V4R7M	4.7μF/35V
C110	2544250026	CE04W0J101M	100μF/6.3V
C111	2544254006	CE04W1C100M	10μF/16V
C112	2544260087	CE04W1H100M	10μF/50V
C113	2544258947	CE04W1V470M	47μF/35V
C120	2544260058	CE04W1H2R2M	2.2μF/50V
C301,302	2544195929	CE04W1V100M	10μF/35V
C303,304	2551134038	CQ92M1H223J	0.022μF/50V
C402	2554121006	CQ93P1H101J	100pF/50V
C403,404	2544260087	CE04W1H100M	10μF/50V
C501	2544260087	CE04W1H100M	10μF/50V
C502	2554129008	CQ93P1H221J	220pF/50V
C503	2554137003	CQ93P1H471J	470pF/50V

Ref. No.	Part No.	Part Name	Remarks
C504	2554141002	CQ93P1H681J	680pF/50V
C505	2551120084	CQ93M1H472J	4700pF/50V
C506	2534262008	CC45SL2H030C	3pF/500V
C507	2543016067	CE04D1H100MBP	10μF/50V
C508	2544260087	CE04W1H100M	10μF/50V
C509	2534269001	CC45SL2H100D	10pF/500V
C510	2554121006	CQ93P1H101J	100pF/50V
C511	2534465902	CC45SL2H050C	5pF/500V
C512	2551134025	CQ92M1H103J	0.01μF/50V
C513	2554137003	CQ93P1H471J	470pF/50V
C514,515	2551135095	CQ92M1H563J	0.056μF/50V
C516,517	2543046008	CE04D2A010MBP	1μF/100V
C518,519	2544256059	CE04W1E221M	220μF/25V
C520	2534281005	CC45SL2H330J	33pF/500V
C521,522	2554121006	CQ93P1H101J	100pF/50V
C523	2544260087	CE04W1H100M	10μF/50V
C524,525	2544181001	CE04W2A010M	1μF/100V
C526,527	2551134025	CQ92H1H103J	0.01μF/50V
C528,529	2561034076	CF93A1H104J	0.1μF/50V
C530,531	2554121006	CQ93P1H101J	100pF/50V
C532,533	2534281005	CC45SL2H330J	33pF/500V
C534,535	2554137003	CQ93P1H471J	470pF/50V
C537~541	2551134025	CQ92M1H103J	0.01μF/50V
C542	2554079048	CQ73P2A103J	0.01μF/100V
C543,544	2543046930	CE04D2A100MBP	10μF/100V
C545	255	CQ92M1H103J	0.01μF/50V
C545,546	2531052004	CK45E2H472P	4700pF/500V
C547	2544260087	CE04W1H100M	10μF/50V
C591	2544195929	CE04W1V100M	10μF/35V
C701	2554080024	CQ93P2A223J	0.022μF/100V

SWITCHES & COILS & RELAYS GROUPS

L501	2350016917	INDUCTOR (180k)	
L701,702	2359001004	INDUCTOR	
▲SW001	2129534002	POWER SW (PUSH)	
SW401	2129554008	4P PUSH SWITCH	
FB501,502	2359006009	BL02RN1-R62	
RL501	2149013008	RELAY (BSR-H-12S)	(UL Model)
RL701,702	2140041008	RELAY	

OTHER PARTS GROUP

	4170253000	RADIATOR	2
	4700012022	Cross Pan Screw with SW, W3x12	2
	4756008006	φ4 NUT	1
	1469123006	SLS-34	4
	2048248000	1P CONNECTOR	1
		BASE	
	2048101008	2P POWER JACK	1
▲F101,102	2061039047	FUSE 1.25A	2

KU9117B for E2

[Same as KU9117 (for EU) except the followings]

Ref. No.	Part No.	Part Name	Remarks
	2020022008	FUSE HOLDER	4
	2050190036	3P NH CONNecTOR BASE	2
	2050233032	3P EH CONNecTOR BASE	1
	2050234031	3P EH SID CONNecTOR BASE	3
	2050190049	4P NH CONNecTOR BASE	2
	2050233045	4P EH CONNecTOR BASE	1
	2050234044	4P EH SID CONNecTOR BASE	1
	2050190052	5P NH CONNecTOR BASE	2
	2050233058	5P EH CONNecTOR BASE	1
	2050243022	2P WIRE HOLDER	9
	2050243035	3P WIRE HOLDER	1
	2050185041	4P WIRE HOLDER	1
	2050243051	5P WIRE HOLDER	1
	2050185054	5P WIRE HOLDER	2
	2050243064	6P WIRE HOLDER	2
	2050075067	6P WRAPPING TERMINAL	1
	2050141001	COMMON PLATE	1
	2030241086	1P CONTACT ASS'Y	2
	2030241028	1P CONTACT ASS'Y	2
	4450057010	CORD CLIP	2
	2034429008	3P CONNECTOR CORD	1
	2034431009	3P CONNECTOR CORD	1
	2036204001	4P CONNECTOR CORD	1
	2038190003	5P CONNECTOR CORD	1
	2038191002	5P CONNECTOR CORD	1
	2038192001	5P CONNECTOR CORD	1
	2040196008	6P CONNECTOR CORD	1

Ref. No.	Part No.	Part Name	Remarks
RELAY			
	2140041008	RELAY (2) DELETE	RL501
	2149003005	RELAY (2) ADD	
	2149005100	RELAY (1) CHANGE	
OTHER PARTS			
	2061039047	FUSE 1.25A (2) DELETE	R524
	2061015016	FUSE (1.25A) (2) ADD	
	5139181002	FUSE LABEL (T1.25A) (2) ADD	
	2412377947	RD14B2E101JNBST CHANGE	

KU9117D for E1

[Same as KU9117 (for EU) except the followings]

Ref. No.	Part No.	Part Name	Remarks
RELAY			
	2140041008	RELAY (2) DELETE	RL501
	2149003005	RELAY (2) ADD	
	2149005100	RELAY (1) CHANGE	
OTHER PARTS			
	2061039047	FUSE 1.25A (2) DELETE	R524
	2061035025	FUSE 1.25A (T) (2) ADD	
	2412377947	RD14B2E101JNBST CHANGE	

KU9118 P.S. UNIT PARTS LIST

Ref. No.	Part No.	Part Name	Remarks
SEMICONDUCTORS GROUP			
D001 002	2760426003	RM-4Y-LF-J1	
D003	2760424005	4D4B42 (LC1)	
D004	2760049011	1S2076A	
D005	2760422007	1D4B41	
RESISTORS GROUP			
R001	2430028003	RW99=3FR22K	0.22Ω, 3W ±10%
R002	2440167022	RS14B3F153JNBF	15kΩ, 3W, ±5%
R003	2432044014	RW78A4A2R2K=	2.2Ω, 10W, ±10%
CAPACITORS GROUP			
AC001	2538003014	CK48E2GAC472M	4700pF/ 400V AC
C003, 004	2544229002	CE04W2A471M	470μF/100V
RELAY GROUP			
RL001	2149004004	RELAY	
OTHER PARTS GROUP			
AF001, 002	2061051025	FUSE 10A	2
AF003, 004	2061046027	FUSE 5A	2
AF005	2061051025	FUSE 10A	1
	2020022008	FUSE HOLDER	4
	EP-5870	FUSE HOLDER	6
	2050190036	3P NH CONNECTOR BASE	1
	2050190049	4P NH CONNECTOR BASE	1
	4450057007	CORD CLIP	2

KU9118B for E2

[Same as KU9118 (for EU) except the followings]

Ref. No.	Part No.	Part Name	Remarks
OTHER PARTS			
R003	2432044014	RW78A4A2R2K=2.2Ω 10W, ±10% DELETE	
	2432044027	RW78A4A4R7K=4.7Ω 10W, ±10% ADD	
OTHER PARTS			
	EP-5870	FUSE HOLDER (6) DELETE	
	2061046027	FUSE 5A (2) DELETE	
	2061051025	FUSE 10A (3) DELETE	
	2061015090	FUSE (5A) (3) ADD	
	2061036011	FUSE (6.3A) (2) ADD	
	5130654020	FUSE LABEL (T5.0A) (2) ADD	
	5130654091	FUSE LABEL (T6.3A) (3) ADD	
	2020022008	FUSE HOLDER (10) ADD	

KU9118D for E1

[Same as KU9118 (for EU) except the followings]

Ref. No.	Part No.	Part Name	Remarks
OTHER PARTS			
	2061046027	FUSE 5A (2) DELETE	
	2061051025	FUSE 10A (3) DELETE	
	2061017043	FUSE 12A (1) ADD	
	2061035012	FUSE 5A (T) (2) ADD	
	2061035096	FUSE 10A (2) ADD	
	EP-5870	FUSE HOLDER (6) DELETE	
	2020022008	FUSE HOLDER (10) ADD	

WIRING DIAGRAM

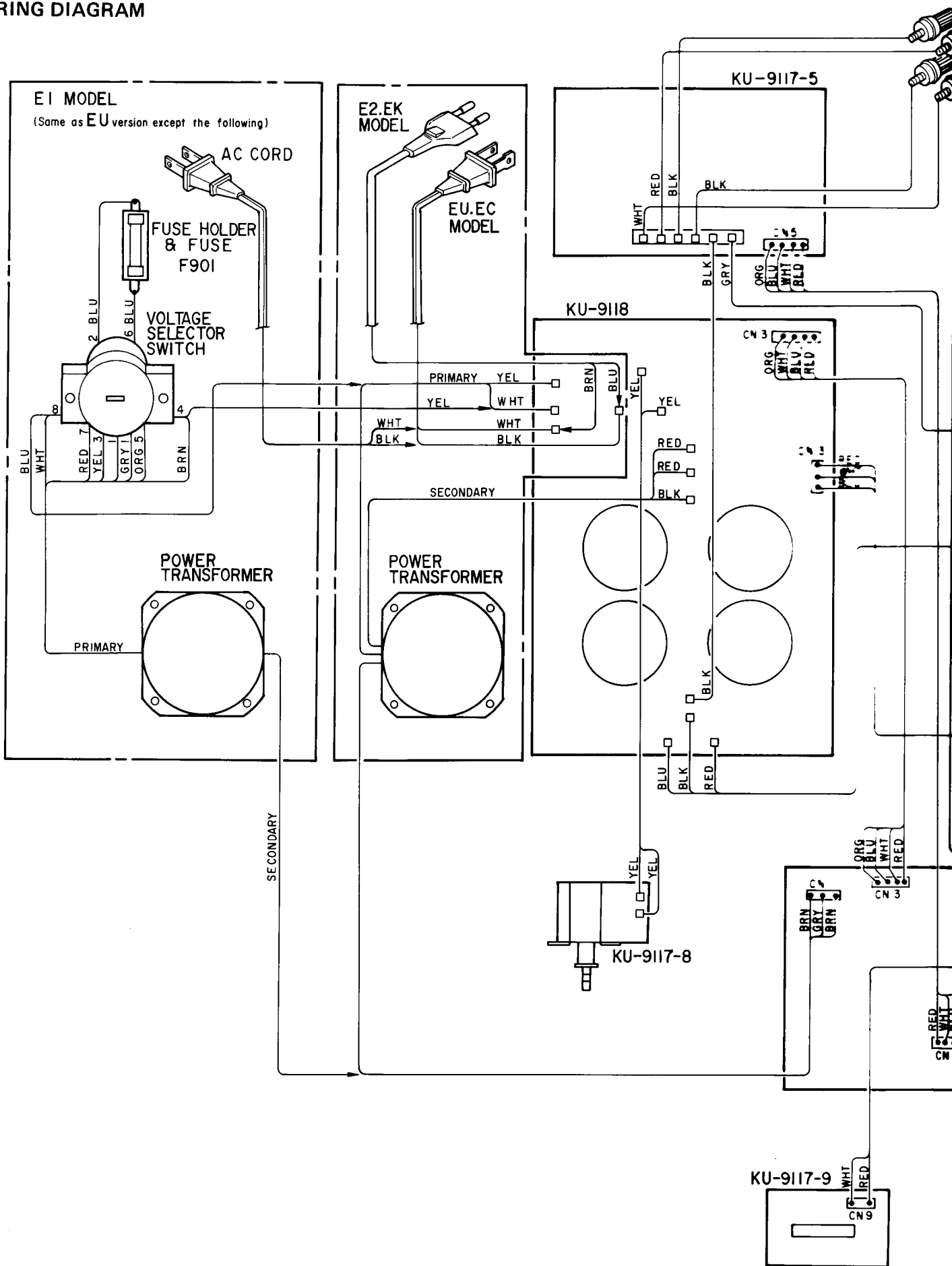

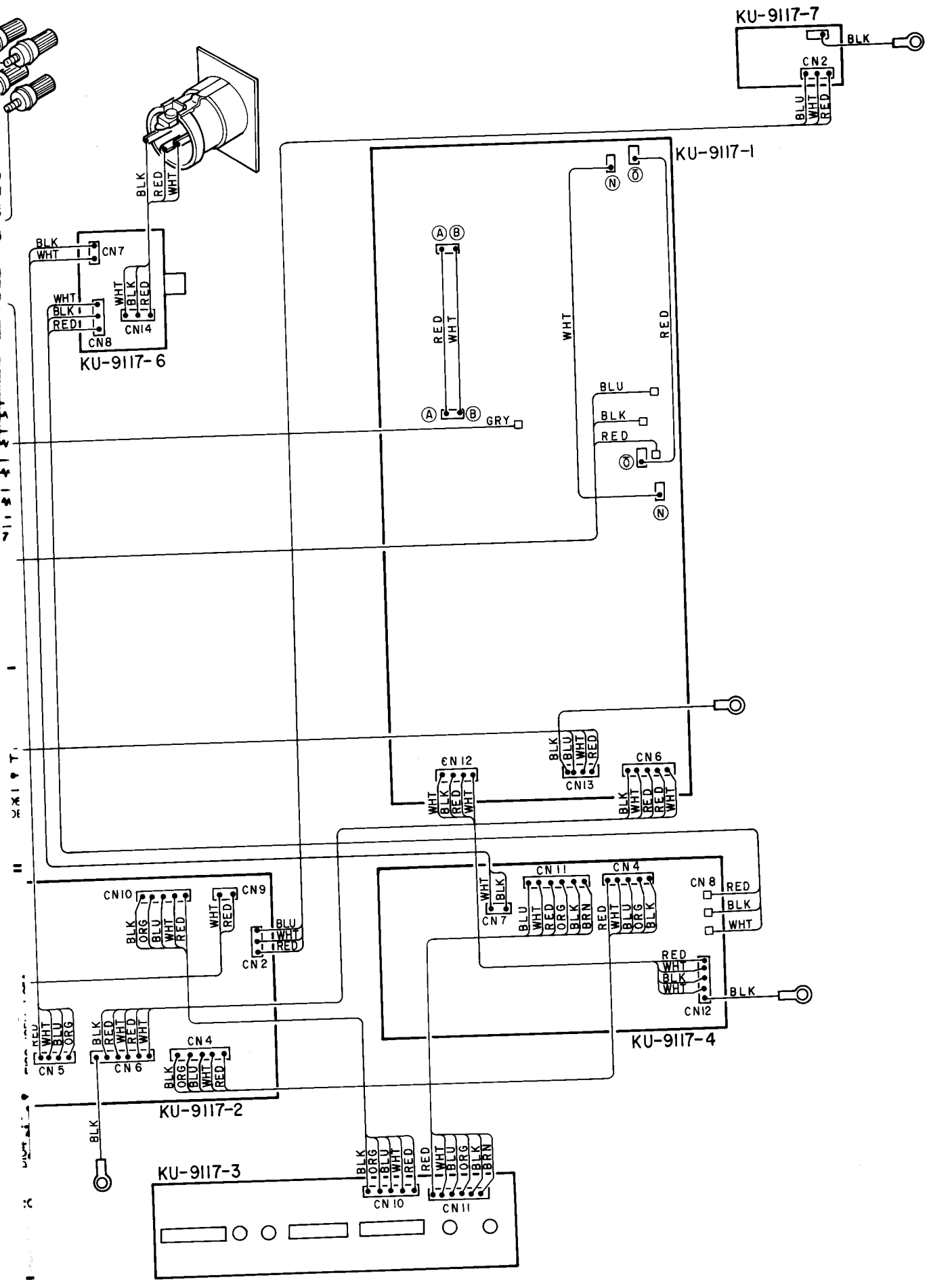

SCHEMATIC DIAGRAM

1

2

3

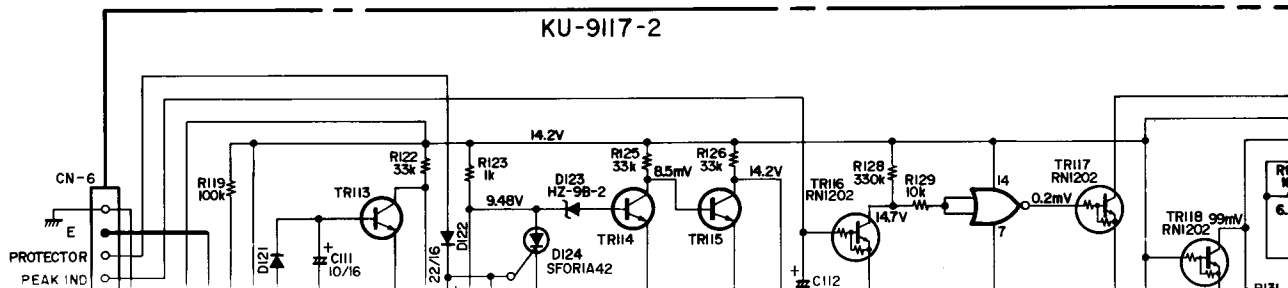
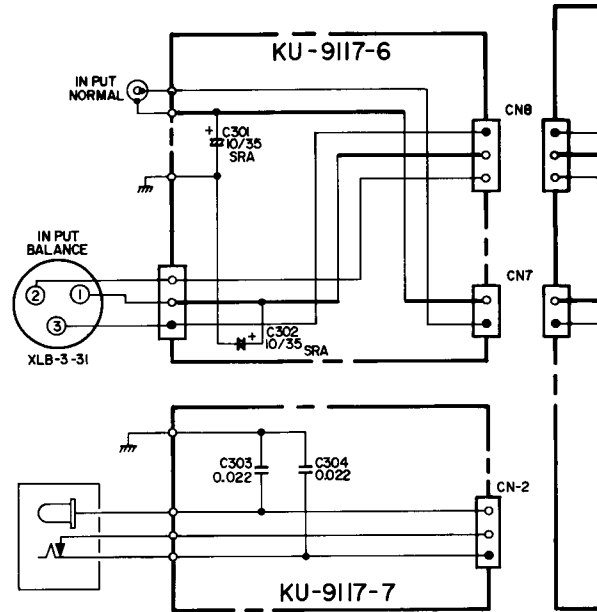
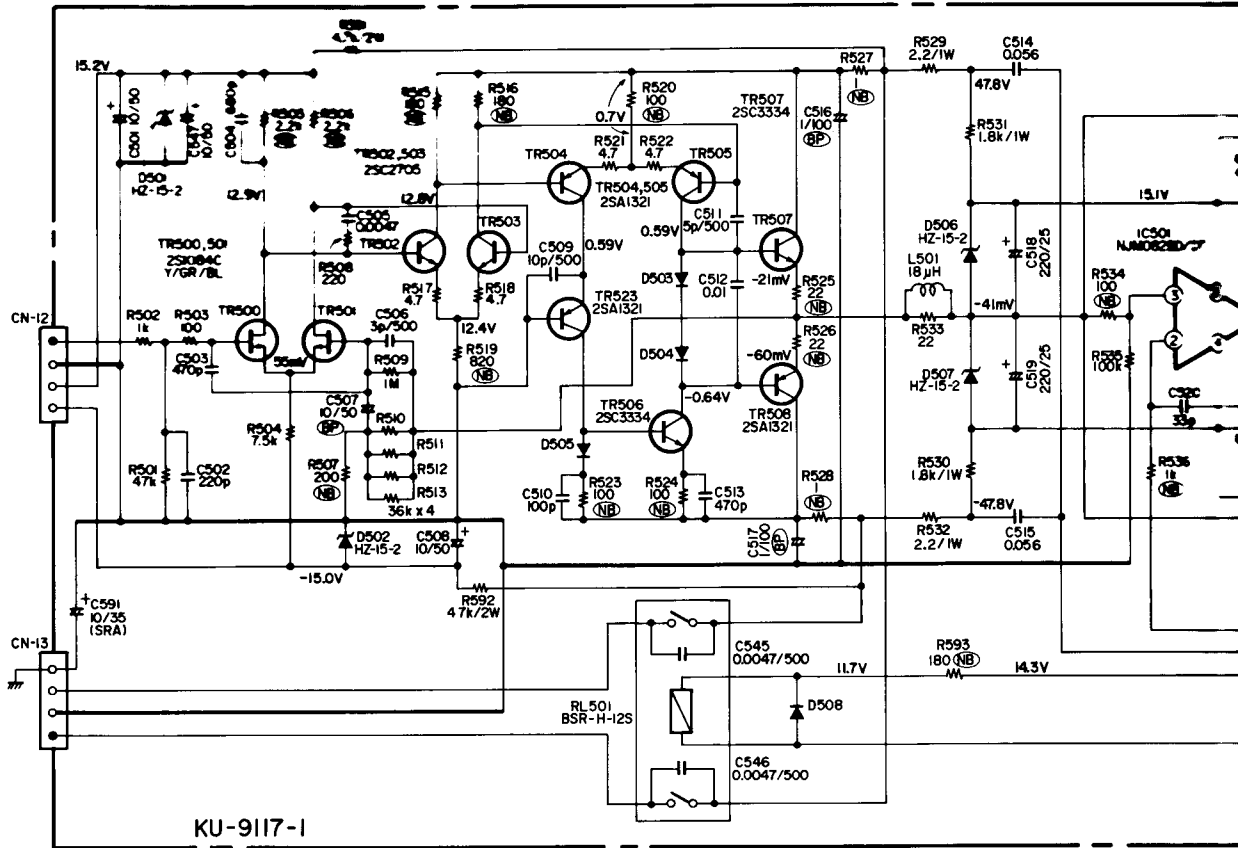

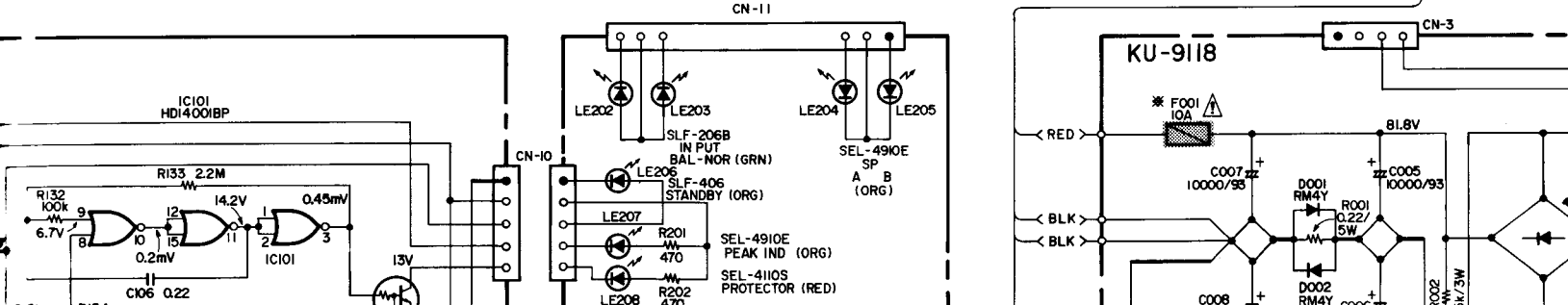
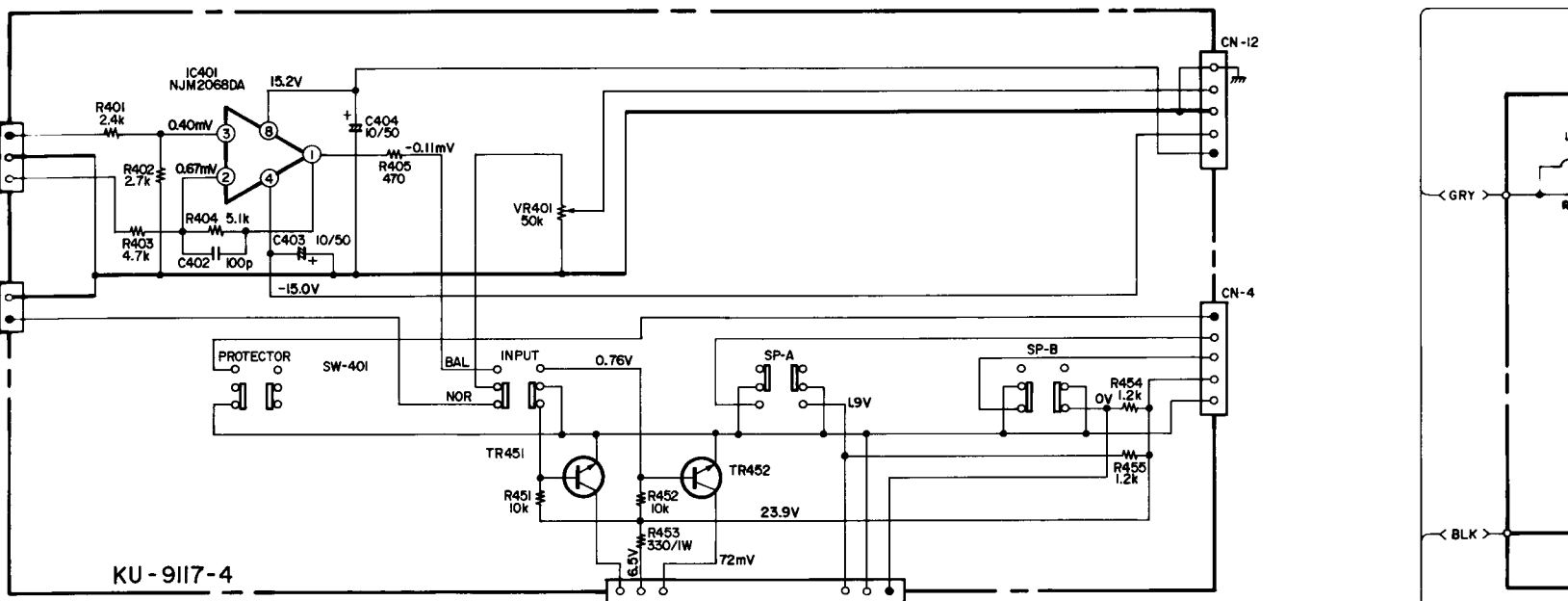
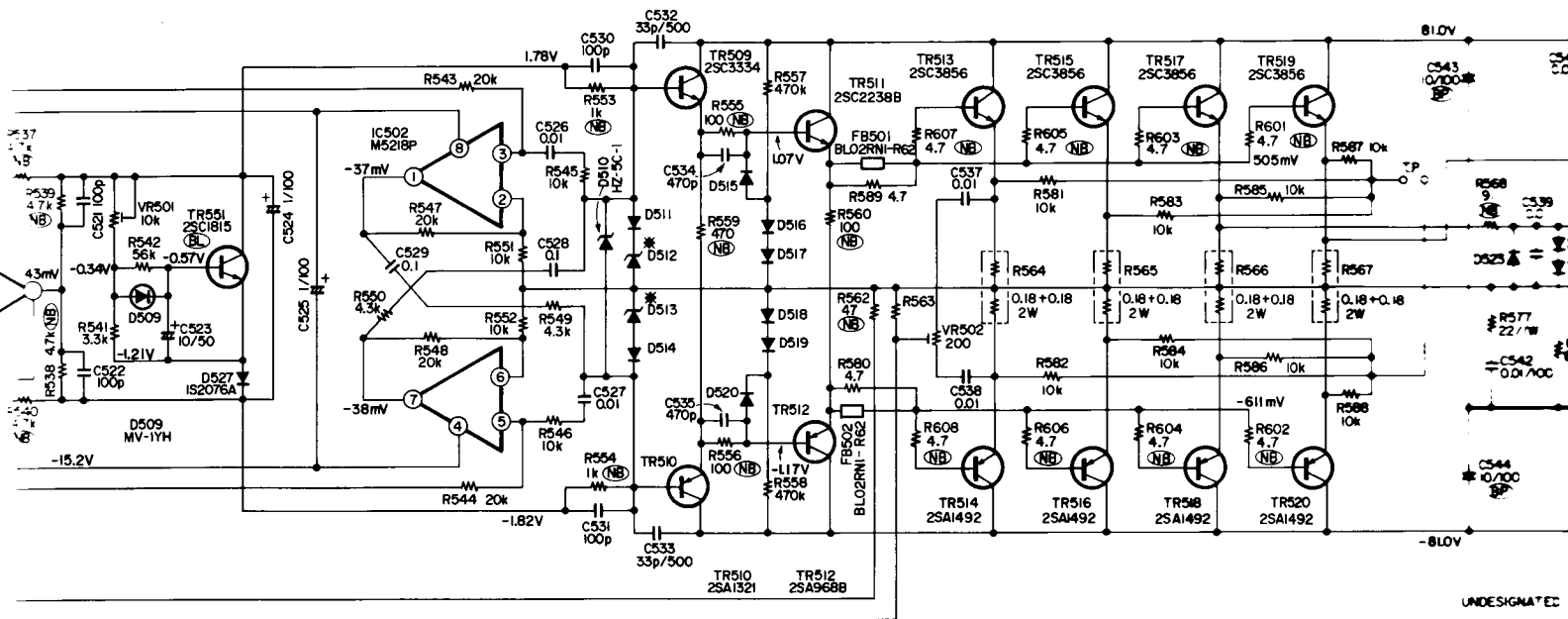

⚠️ Means important safety item, which must be replaced, when necessary, by a part specified or meeting the specification by the manufacturer.

7

8

9

10

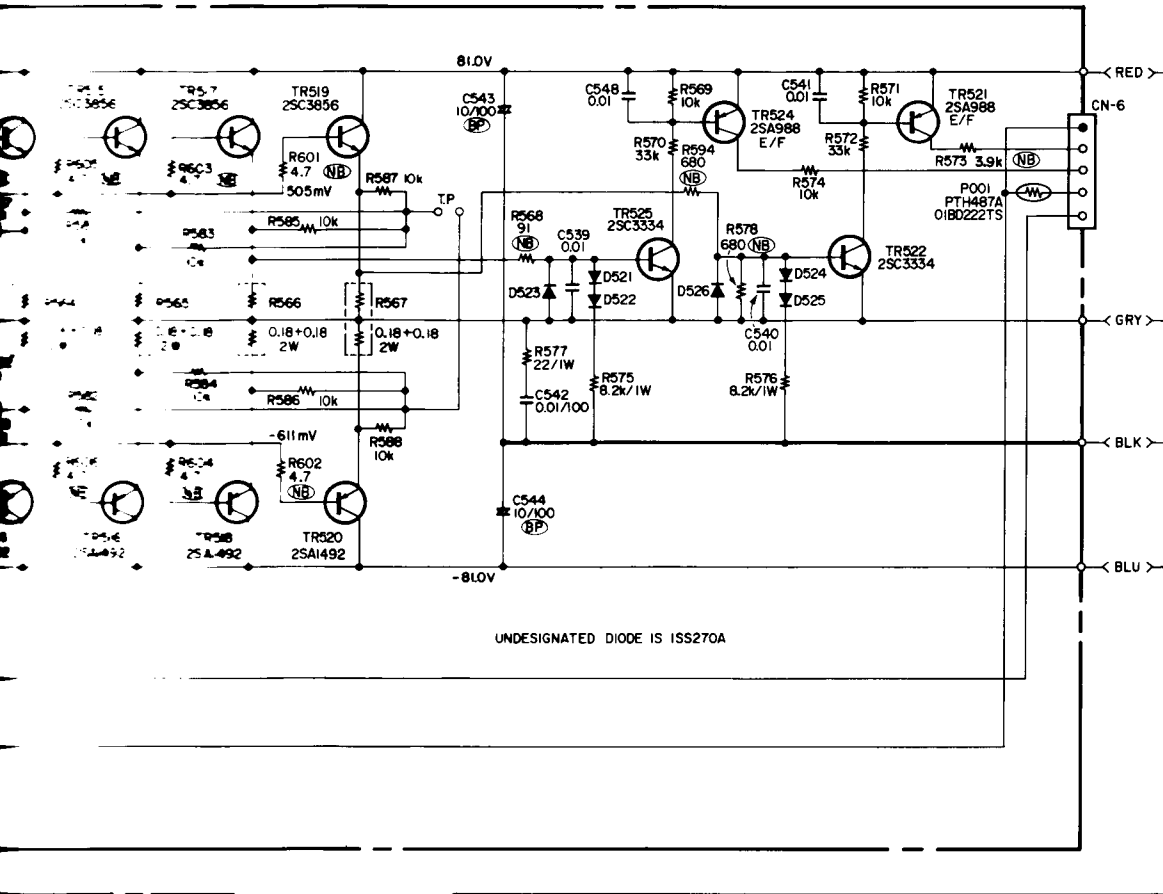

A

B

C

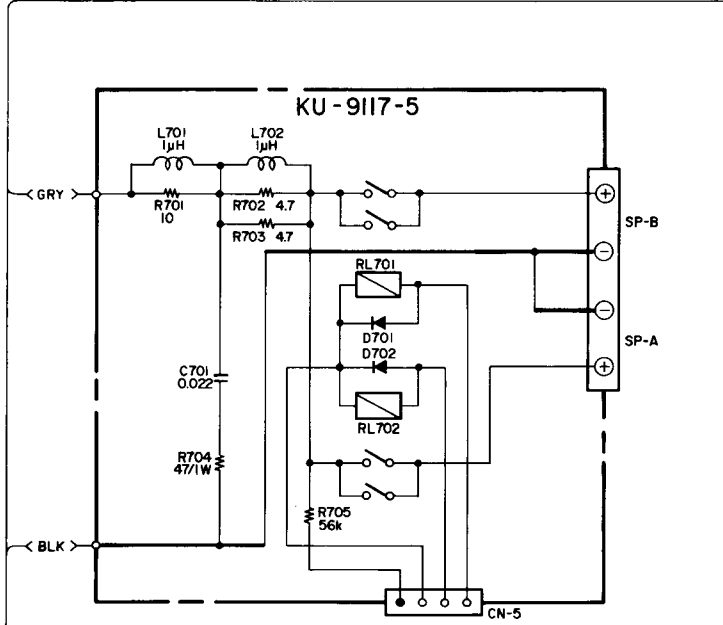
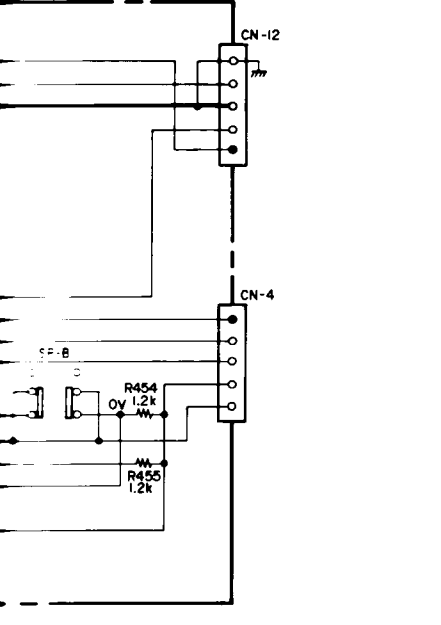

D

E

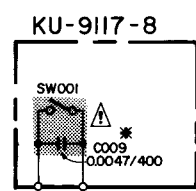
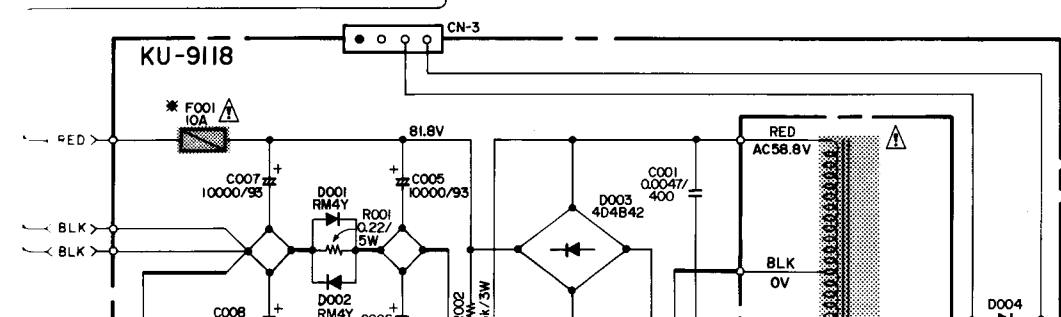

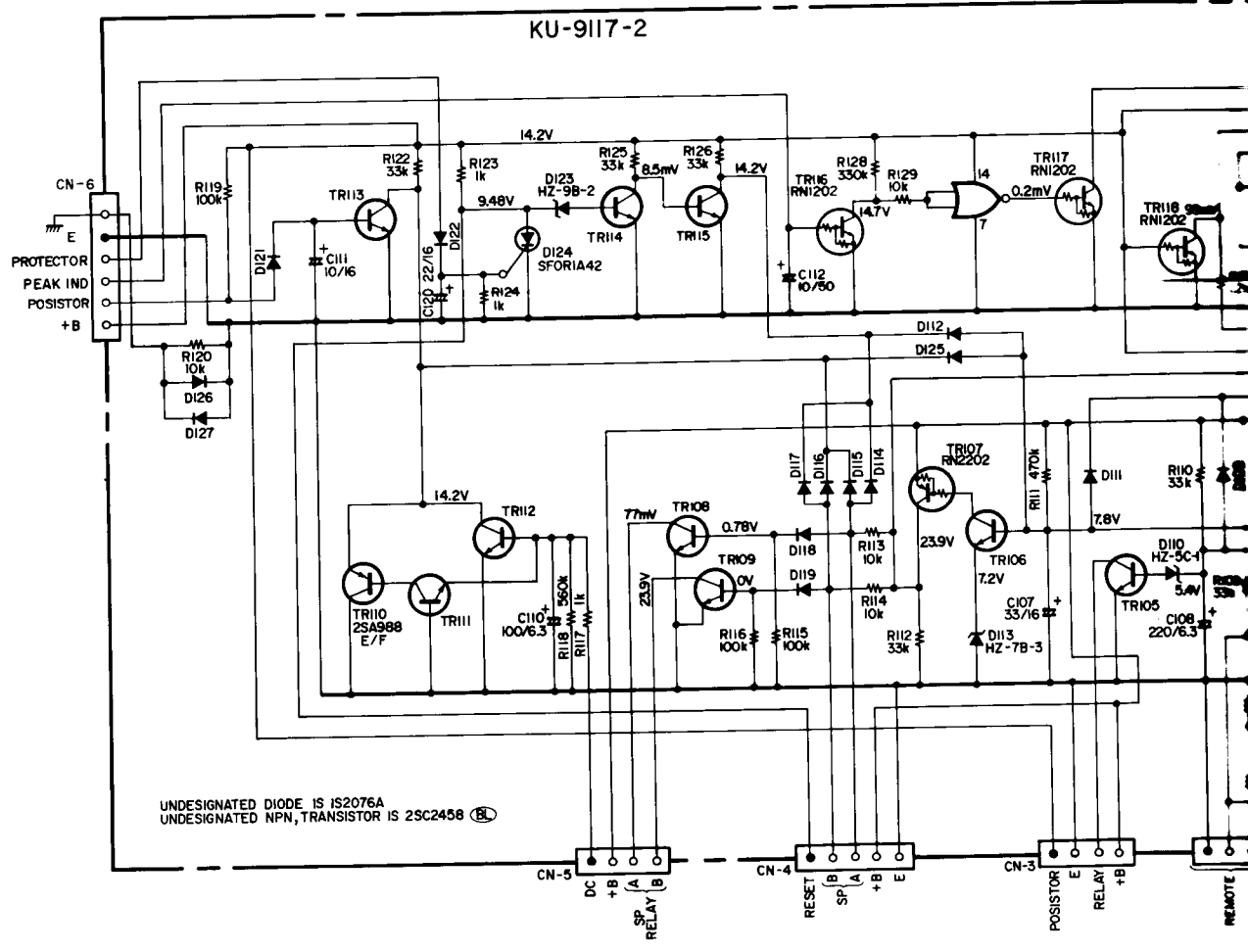
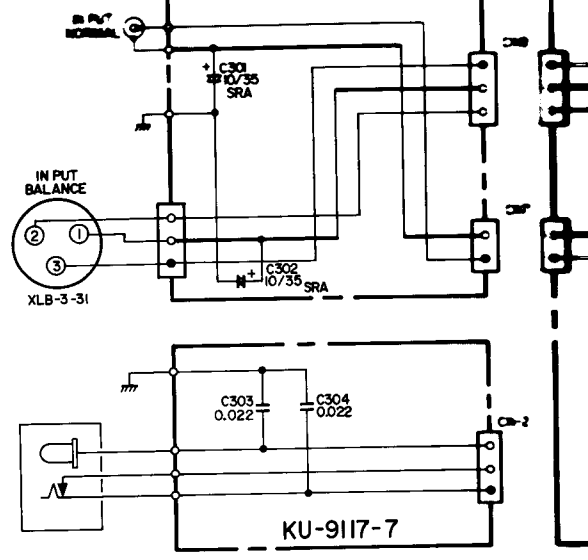

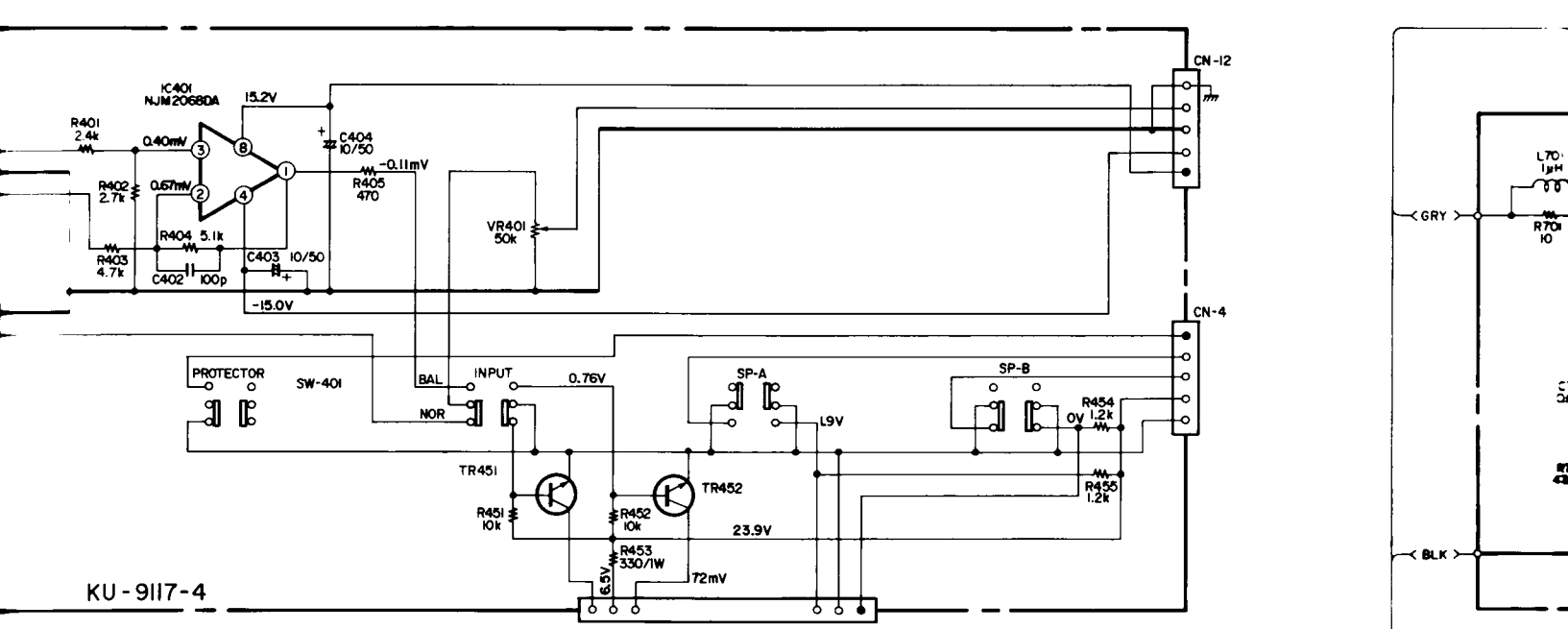

KU-9117-4

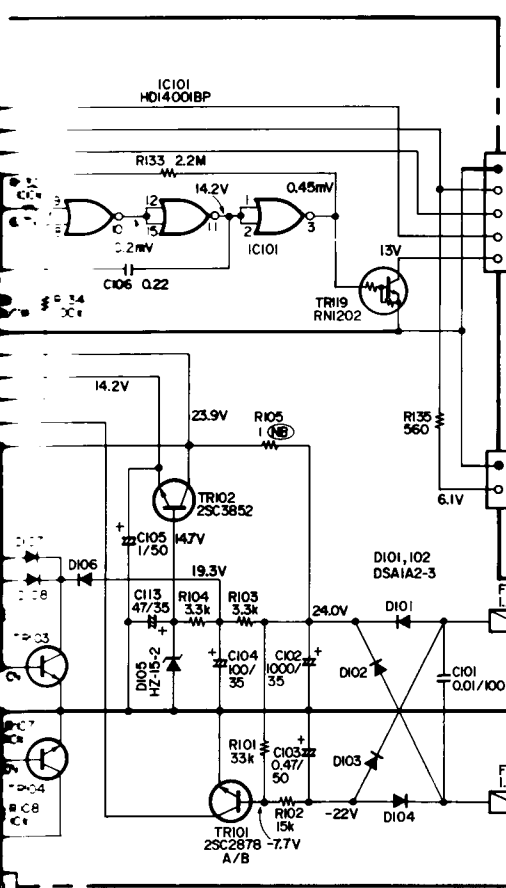

KU-9117-3

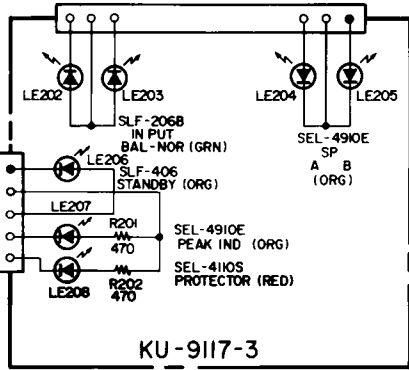

KU-9117-9

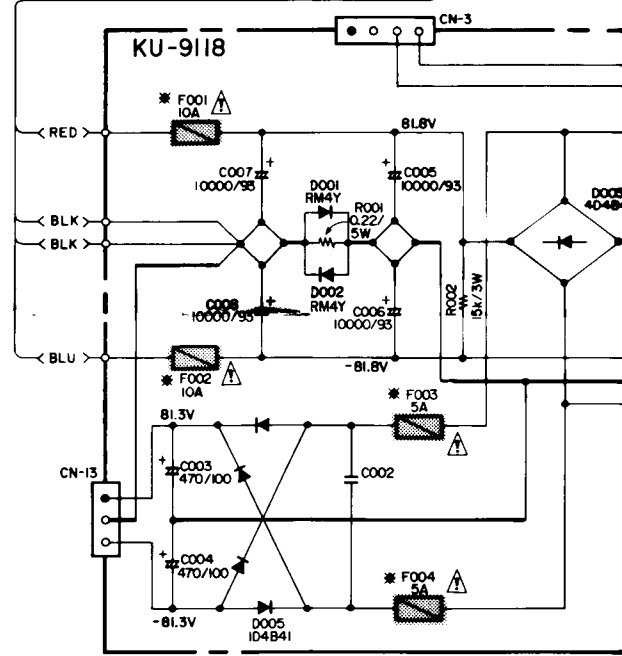

KU-9118

* CONDENSER

	CO10	CO09
EU	NOT Applicable	0.0047 125V ~
E2	0.01 250V ~	0.0047 400V ~

* FUSE

	FO01,002	FO03,004	FO05
EU	10A 125V ~	5A 125V ~	10A 125V ~
E2	T6.3A 250V ~	T5A 250V ~	T5A 250V ~

* RESISTANCE

	RO03
EU	2.2/10W
E2	4.7/10W

POWER TRANS.

Version	Part NO.
EU	2339572003
E2	2339575000
E1	2339576009

* D512, 513

EU	HZ-7B-3
E2	HZ-5C-1
E1	HZ-5C-1

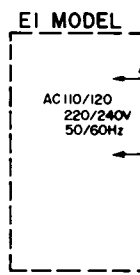

NO
AL
AL
EA
CIP

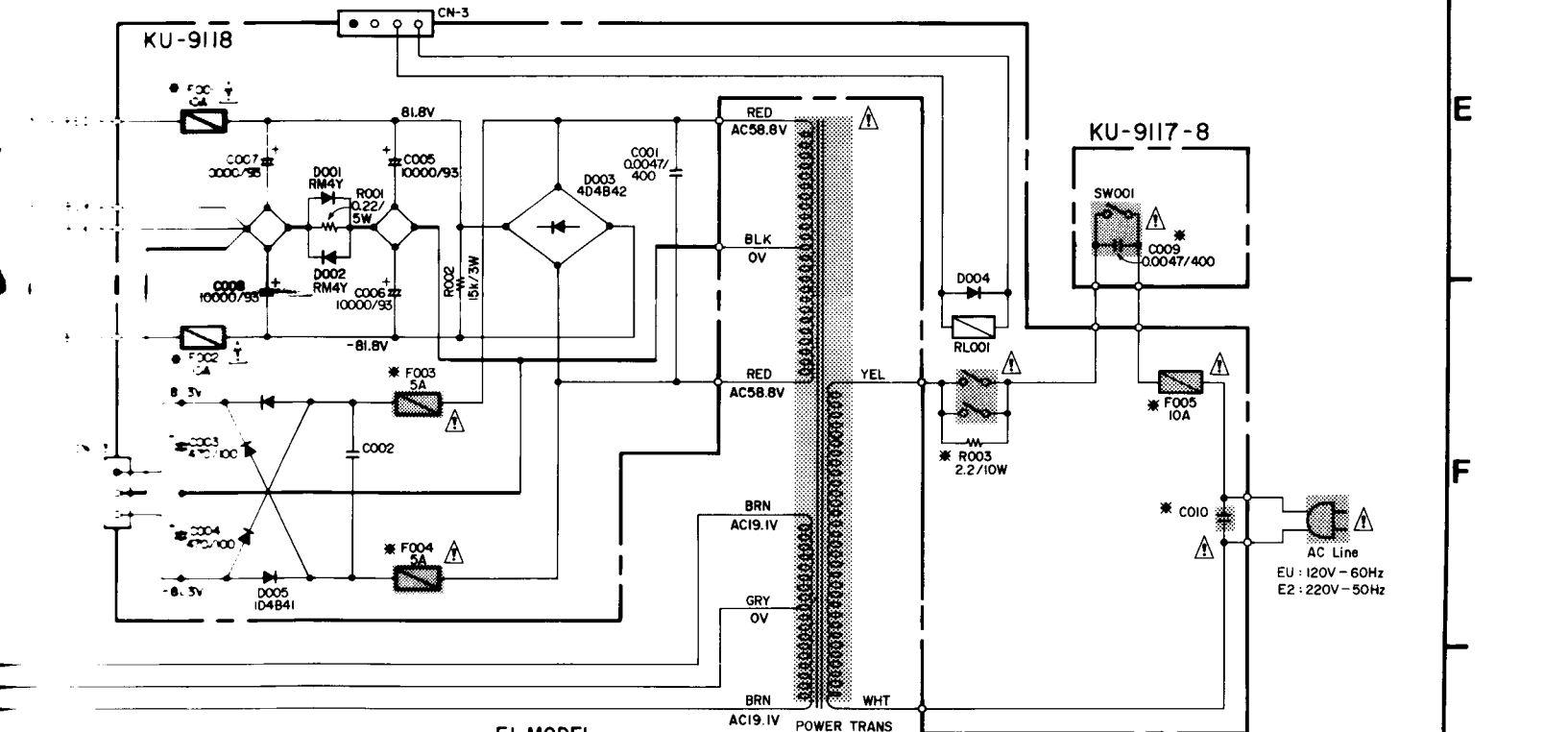
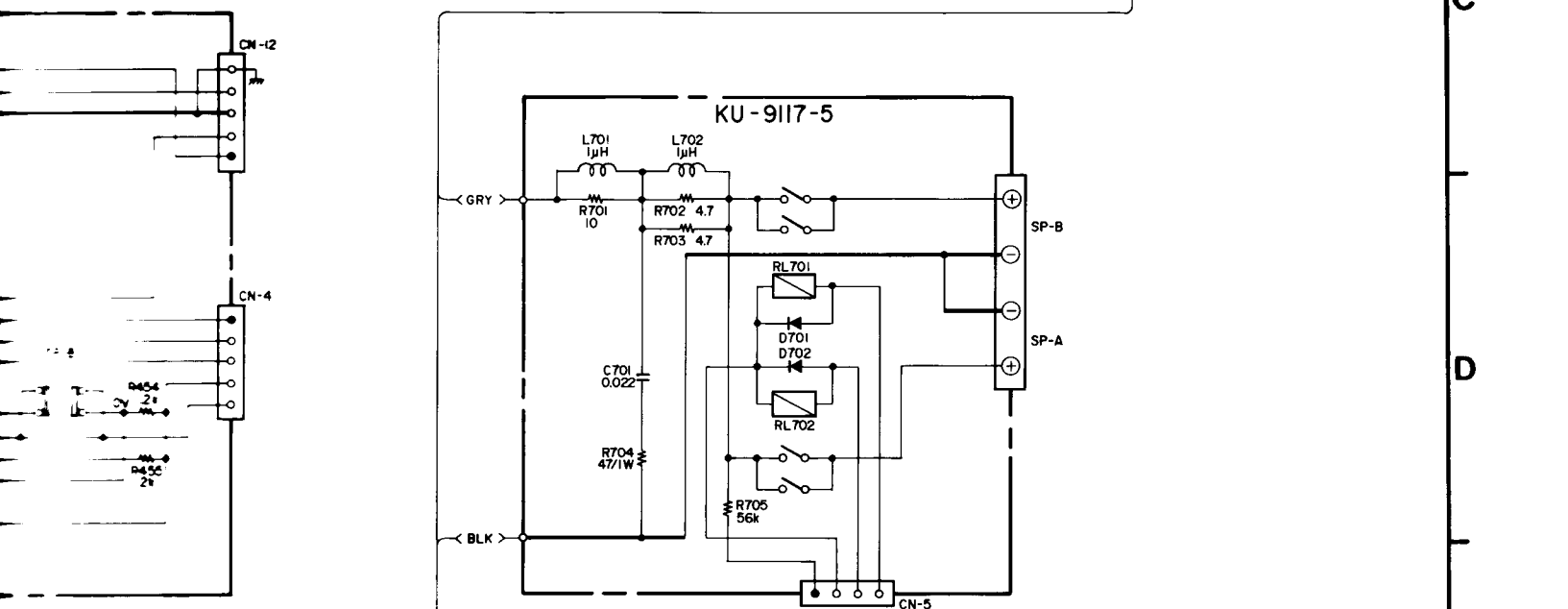

F001	F004	F005
1A 250V	1A 250V	1A 250V
1A 250V	1A 250V	1A 250V
1A 250V	1A 250V	1A 250V

2339572003
2339575000
2339576009

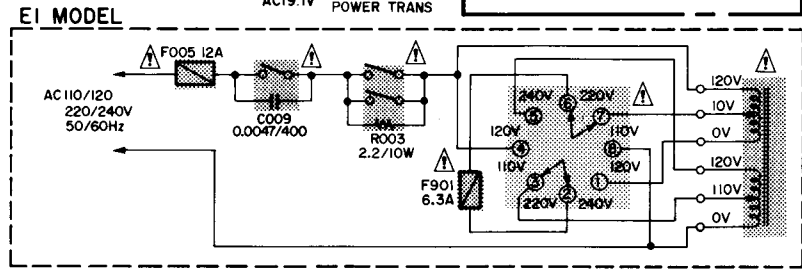

NOTES
 ALL RESISTANCE VALUES IN OHM K = 1,000 OHM M = 1,000,000 OHM
 ALL CAPACITANCE VALUES IN MICRO FARAD P = MICRO-MICRO FARAD
 EACH VOLTAGE AND CURRENT ARE MEASURED AT NO SIGNAL INPUT CONDITION.
 CIRCUIT AND PARTS ARE SUBJECT TO CHANGE WITHOUT PRIOR NOTICE.

EXPLODED VIEW OF CHASSIS AND CABINET & PARTS LIST

1

2

3

4

EXPLODED VIEW OF CHASSIS AND CABINET

A

B

C

D

E

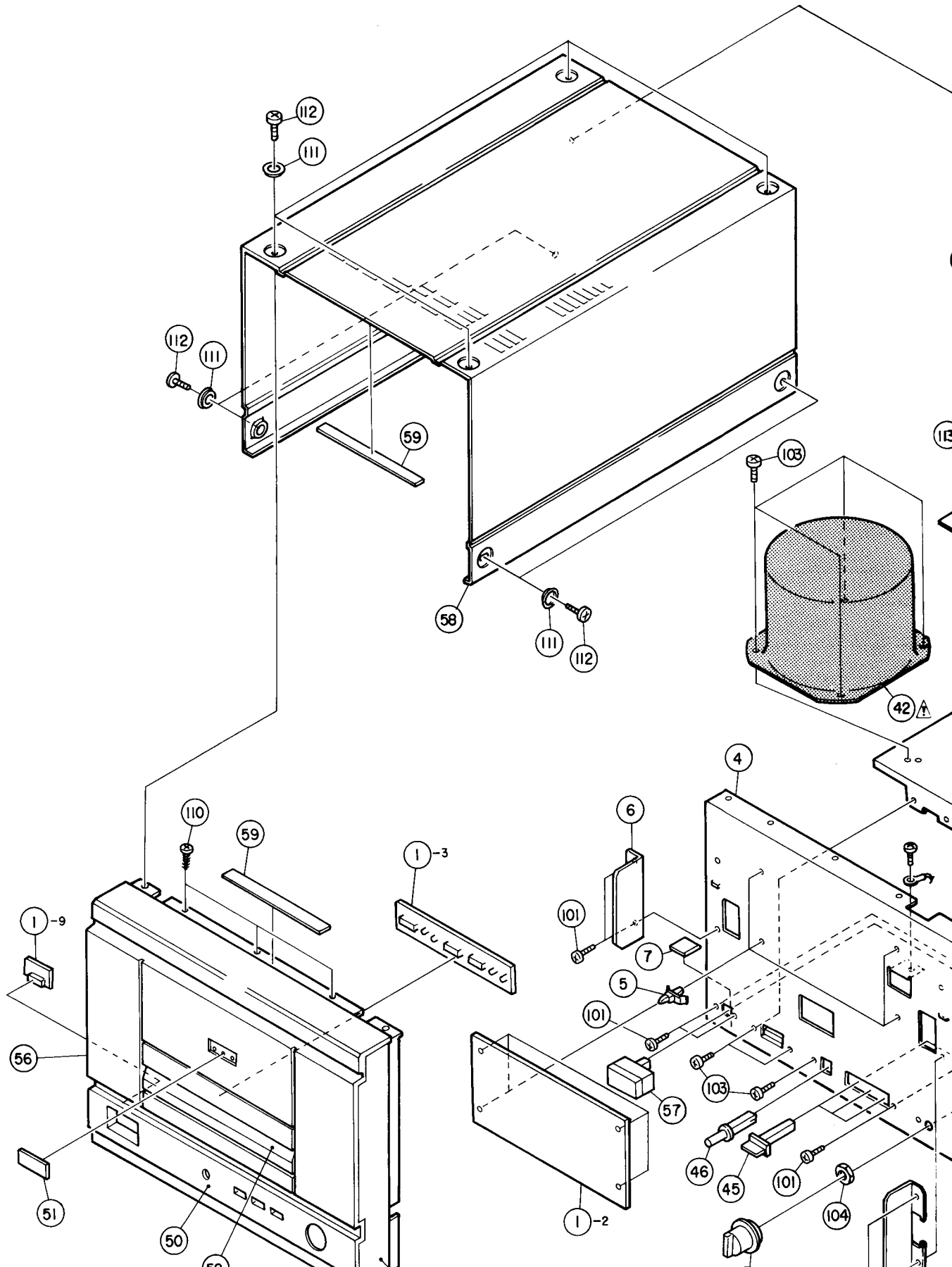

⚠  Means important safety item, which must be followed when necessary, by a part specified or meeting the specifications by the manufacturer.

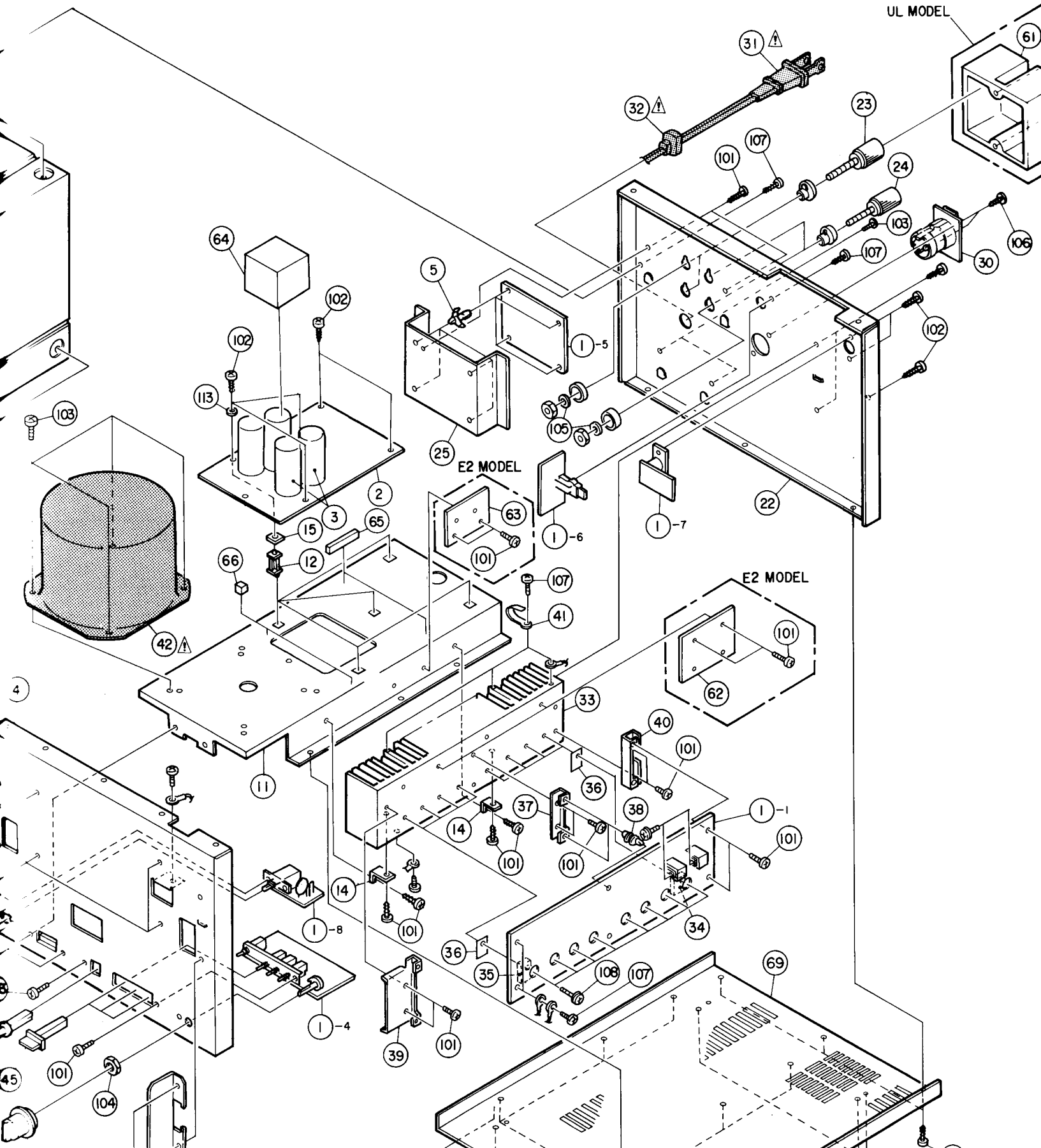

Important safety item, which must be replaced,
 by a part specified or meeting the specification
 refer.

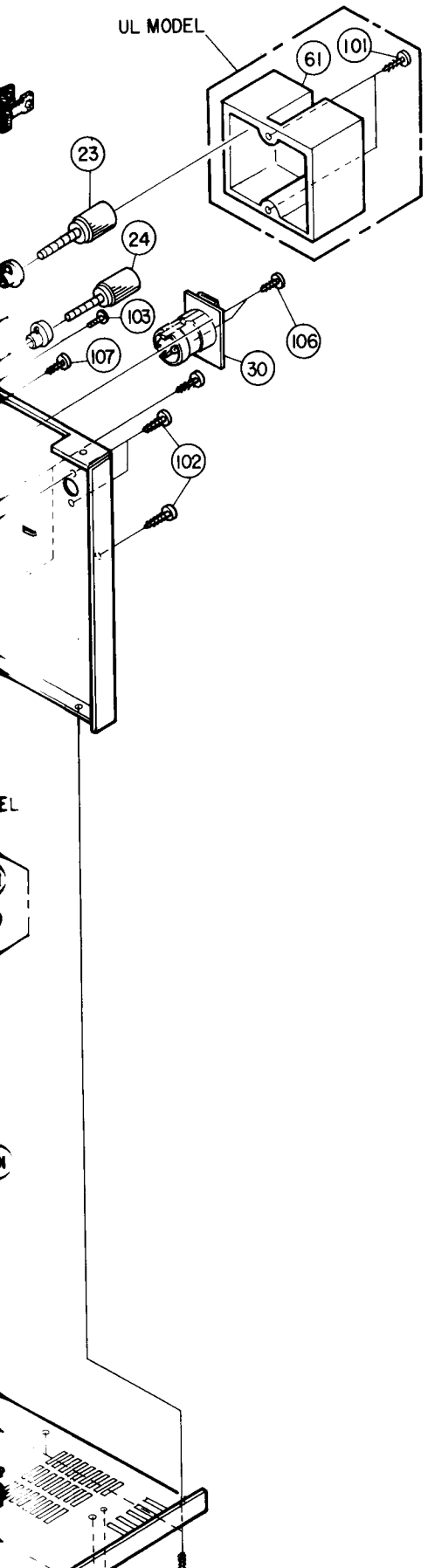

PARTS LIST OF EXPLODED VIEW

Ref. No.	Part No.	Part Name	Remarks
* 1	KU9117	POWER UNIT	1
* 2	KU9118	P.S. UNIT	1
3	2546122000	CE68W==103M 10,000μF	4 C005~008
4	4119051108	FRONT CHASSIS	1
* 5	4159016019	P.C.B HOLDER	8
6	4129132101	BRACKET	2
* 7	4150210005	INSULATING SHEET	1
* 8	2034433007	3P CONNECTOR CORD	1
* 9	2036202003	4P CONNECTOR CORD	1
* 10	2036203002	4P CONNECTOR CORD	1
* 11	4119052107	TRANS. CHASSIS	1
12	4159032006	P.C.B HOLDER (T)	5
14	4129059019	BRACKET	2
* 15	4159018017	INSULATING SHEET	3
* 16	2034430000	3P CONNECTOR CORD	1
* 17	2034432008	3P CONNECTOR CORD	1
* 18	2036204001	4P CONNECTOR CORD	1
* 19	2090247088	VINYL WIRE	2
* 20	5139182014	FUSE LABEL	1
* 21	2090206032	D.I. WIRE	1
* 22	1059094008	BACK PANEL	1
* 23	2050115008	1P TERMINAL (BLACK)	2
* 24	2050115011	1P TERMINAL (RED)	2
* 25	4129138105	BRACKET (SP)	1
* 26	2090247075	VINYL WIRE	1
* 27	2090247020	VINYL WIRE	1
* 28	2090247033	VINYL WIRE	1
* 29	2090247046	VINYL WIRE	1
30	2050416008	3P CANNON CON- NECTOR	1
* Δ 31	2062039004	AC CORD (POLAR- IZED)	1
Δ 32	4460020005	CORD BUSH (4k-4)	1
33	4179032303	POWER RADIATOR	1
34	2710221009	2SA1492LB O/P/Y	4
35	2730355007	2SC3856LB O/P/Y	4
36	4150234007	INSULATING SHEET	8
37	4129137106	PWB SUPPORT BRACKET	1
38	4159033005	P.C.B HOLDER (R)	2
39	4129130103	RADIATOR BRACKET (F)	1
40	4129131102	RADIATOR BRACKET (B)	1
41	4450048016	CORD HOLDER (L50)	3
* Δ 42	2339572003	POWER TRANS.	1
* 43	4450033005	WIRE CLAMP BAND	10
44	1129041004	KNOB	1
45	1139151007	PUSH KNOB	3
46	1139087100	PUSH KNOB (PROTECTOR)	1
* 47	5139182001	FUSE LABEL	1
* 48	5139182027	FUSE LABEL	1
* 49	5139182030	FUSE LABEL	1
50	1449062006	FRONT PANEL	1
51	1319005203	DENON MARK	1
52	1469122007	ESC BASE ASS'Y	1

D

E

F

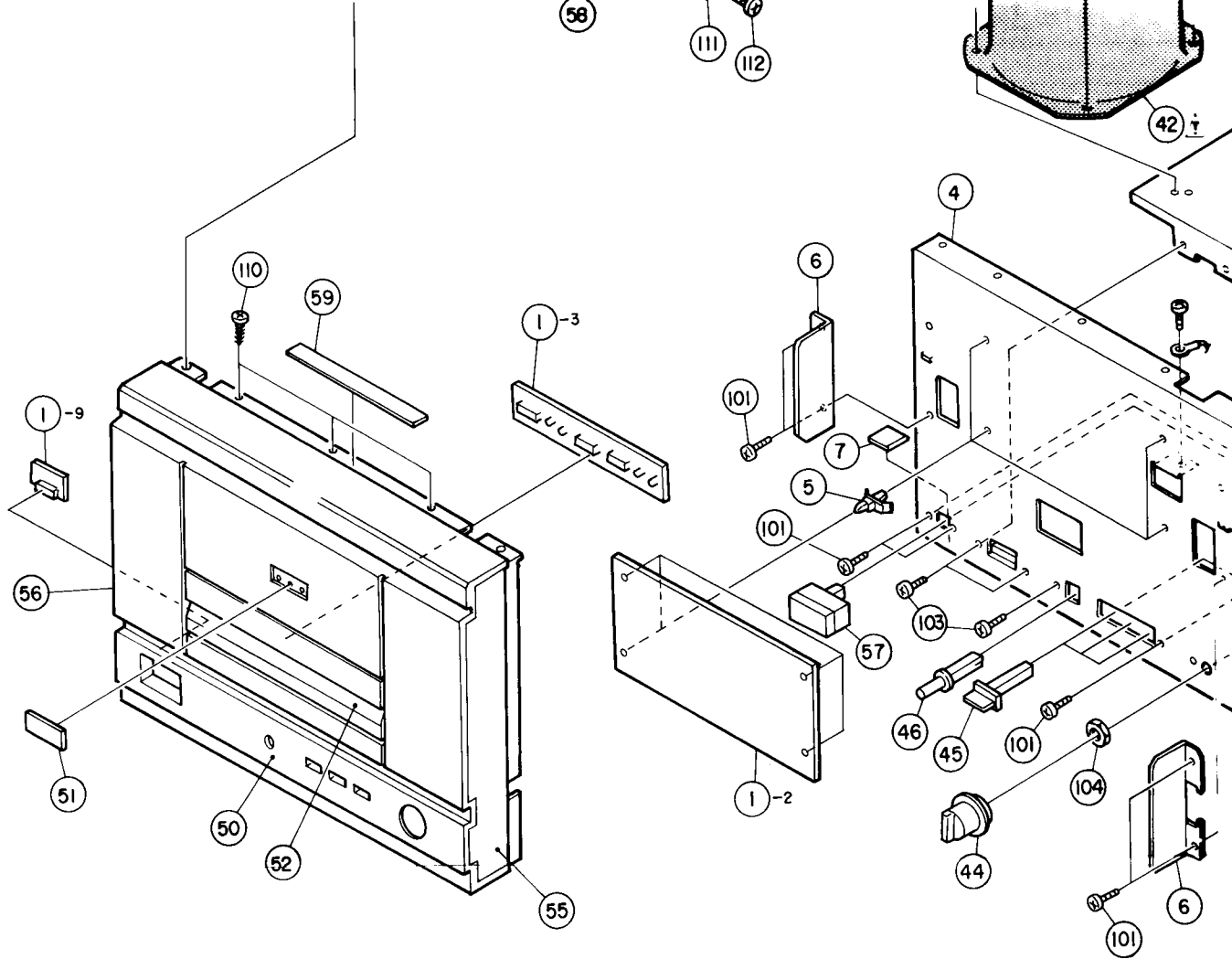

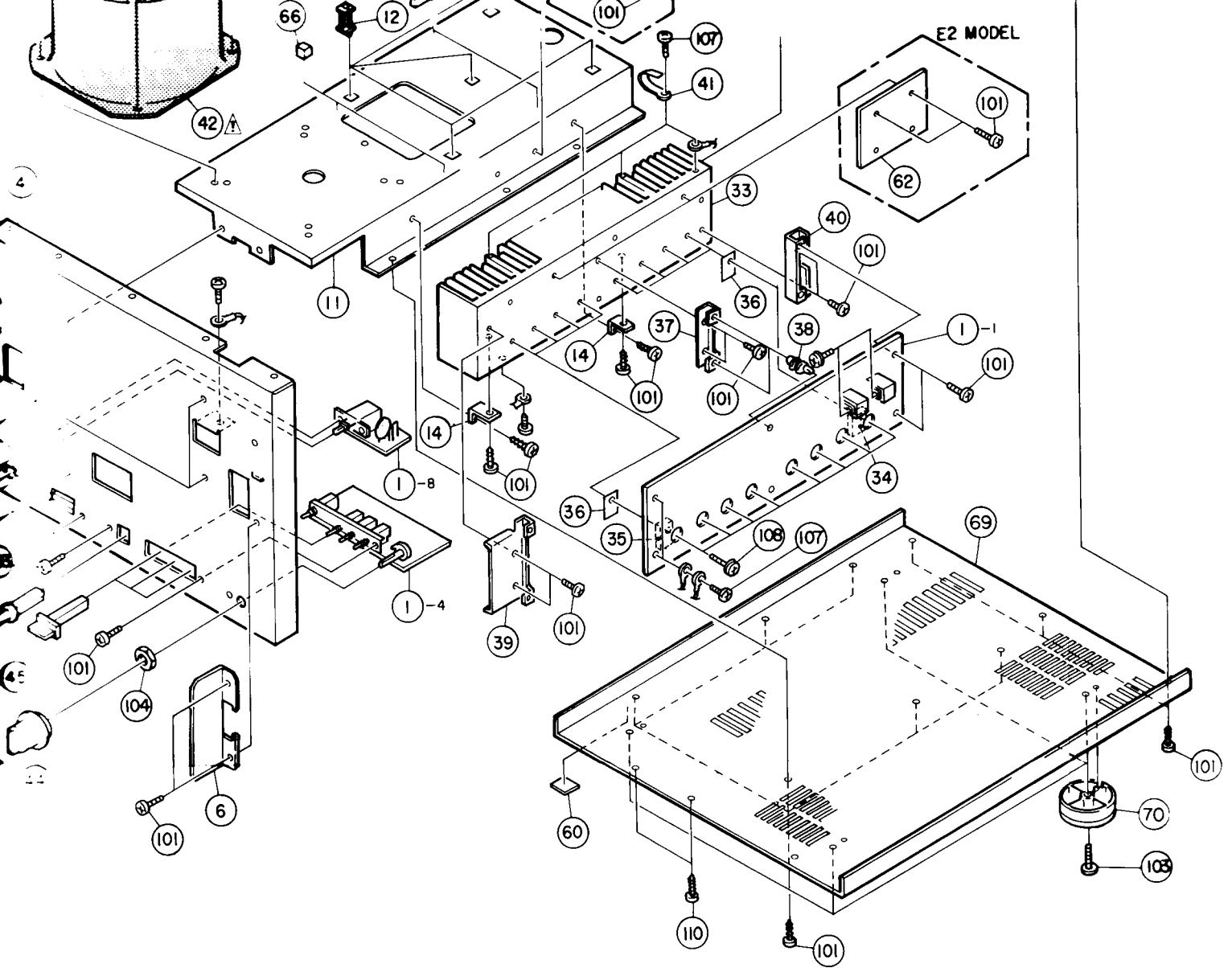

PACKING & ACCESSORIES
(not included EXPLODED VIEW)

Ref. No.	Part No.	Part Name	Remarks
201	5049102003	STYLEN PAPER	1
202	5050075051	CABINET COVER	1
203	5039150007	CUSHION	2
204	5019128062	CARTON CASE	1
205	5058006019	ENVELOPE	1
206	5119223003	INST MANUAL	1
207	2034442001	REMOTE PLUG CORD	1
*208	5150418000	DAI WARRANTY HOME	1

Ref. No.	Part No.	Part Name
SCREWS & NUTS		
* 101	4737002034	TAPTIGHT SCREW 3x6 BLACK
* 102	4737500044	TAPTIGHT SCREW 3x8 BLACK
103	4737007000	TAPTIGHT SCREW 4x8 BLACK
104	-	NUT M7
* 105	4752005003	φ5 SPRING WASHER
106	4737012008	TAPPING SCREW 3 x 10
* 107	4770064107	FIXING SCREW
108	4738007009	CUP SCREW 3x12
110	4737002021	TAPTIGHT SCREW 3 x 8 BLACK
111	1469116000	SCREW CUP
112	4737007013	TAPTIGHT SCREW 4x10 BLACK
113	4419025009	PLATE (WA)

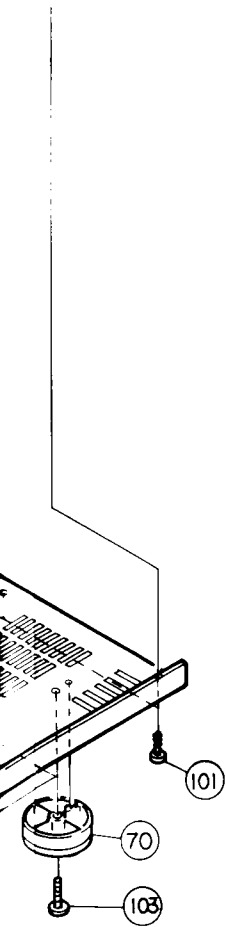

30	2050416008	3P CANNON CON- NECTOR	1
33	4179032303	POWER RADIATOR	1
34	2710221009	2SA1492LB O/P/Y	4
35	2730355007	2SC3856LB O/P/Y	4
36	4150234007	INSULATING SHEET	8
37	4129137106	PWB SUPPORT BRACKET	1
38	4159033005	P.C.B HOLDER (R)	2
39	4129130103	RADIATOR BRACKET (F)	1
40	4129131102	RADIATOR BRACKET (B)	1
41	4450048016	CORD HOLDER (L50)	3
* Δ 42	2339572003	POWER TRANS.	1
*43	4450033005	WIRE CLAMP BAND	10
44	1129041004	KNOB	1
45	1139151007	PUSH KNOB	3
46	1139087100	PUSH KNOB (PROTECTOR)	1
* *47	5139182001	FUSE LABEL	1
* *48	5139182027	FUSE LABEL	1
* *49	5139182030	FUSE LABEL	1
50	1449062006	FRONT PANEL	1
51	1319005203	DENON MARK	1
52	1469122007	ESC BASE ASS'Y	1
*53	1149008001	KNOB GUIDE	1
*54	1469121008	KNOB GUIDE(P) ASS'Y	1
55	1469119007	SIDE ESC PLATE (R)	1
56	1469120009	SIDE ESC PLATE (L)	1
57	1139152006	PUSH KNOB (P) ASS'Y	1
58	1029024105	TOP COVER	1
59	1229006017	SPACER	2
* 60	5138266009	DANGEROUS MARK	1
61	1469124005	PROTECTOR	1
62	4179033001	RADIATOR	2
63	4129148001	PLATE	1
64	4619013028	CUSHION	1
65	4619013015	CUSHION	2
66	4619013002	CUSHION	2
*67	2090248003	TWIST WIRE	1
*68	2090206029	D.I. WIRE	1
69	1059092107	BOTTOM COVER	1
70	1040151109	FOOT ASS'Y	4

Part No.	Part Name	Remarks
SCREWS & NUTS		
737002034	TAPTIGHT SCREW(S) 3x6 BLACK	32
737500044	TAPTIGHT SCREW (P) 3x8 BLACK	7
737007000	TAPTIGHT SCREW (S) 4x8 BLACK	12
-	NUT M7	1
752005003	φ5 SPRING WASHER	4
737012008	TAPPING SCREW (S) 3 x 10	2
770064107	FIXING SCREW	10
738007009	CUP SCREW 3x12	8
737002021	TAPTIGHT SCREW (S) 3 x 8 BLACK	6
469116000	SCREW CUP	8
737007013	TAPTIGHT SCREW (S) 4x10 BLACK	8
419025009	PLATE (WA)	3

ADDENDUM LIST

Ref. No.	Part Name & Descriptions	Part No.		
		E1 for Asia	E2 for Europe	
1	POWER UNIT	KU9117D	KU9117B	
2	PS UNIT	KU9118D	KU9118B	
3	FUSE HOLDER	4159016019(4)	4159016019(4)	
4	INSULATING SHEET	4150210005(2)	4150210005(1)	
11	TRANS CHASSIS	4119052204	4119052107	
13	INSULATING SHEET	4159018004(3)	-	
19	WIRE	-	-	
20	FUSE LABEL	-	-	
22	BACK PANEL	1059098004	1059096006	
23	1P TERMINAL (BLACK)	-	-	
24	1P TERMINAL (RED)	-	-	
25	BRACKET (SP)	-	-	
		2006031026	2062002031	
		2338530000	2338530000	
*41	FUSE LABEL	-	-	
*42	FUSE LABEL	-	-	
*43	FUSE LABEL	-	-	
*50	DANGEROUS MARK	-	-	
71	1P CANNON PLUG CORD	-	2034451005	
72	4P TERMINAL	2050316001	2050316001	
73	WIRE	2090206003 (2)	2090206003 (2)	
74	PROTECTOR SHEET	4159014105	4159014105	
75	CONTROL CARD	-	5131167008	
76	COLOR LABEL (BLACK)	-	5139111014 (2)	
77	BLIND SHEET (FTZ)	-	5139132006	
78	VOLTAGE SEL SWITCH	2129555007	-	
79	FUSE HOLDER	2020013101	-	
80	FUSE BOARD	2061035038	-	
*81	FUSE LABEL T6.3A	5130654091	-	
101	TAPTIGHT SCREW(S) 3x6 BLACK	4737002034 (35)	4737002034 (32)	
102	TAPTIGHT SCREW(S) 3x8 BLACK	4737500044 (9)	4737500044 (9)	
106	1/8 SPRING WASHER	-	-	
107	FIXING SCREW	4770064107 (8)	4770064107 (8)	
206	DAI WARRANTY HOME	-	-	

Note 1 See addendum list above for the parts with asterisk (*) on the Ref. No. and the other parts not included in the list.
 2 *marked not included EXPLODED VIEW OF CHASSIS AND CABINET.
 3 This list is prepared based on EU BLACK VERSION.

WARNING:

1. Component parts

Parts marked with  and/or shading in this service manual have special characteristics important to safety. Be sure to use the specified parts for replacement.

2. Leakage current

Before returning the appliance to customer, test the leakage current when the power plug is connected. Use a calibrated (with an error of not more than 5%) leakage current tester and measure the leakage current from any exposed metal to the earth ground. Reverse the power plug polarity and test the above again.

Any current measured **MUST NOT EXCEED 0.5 milliamps**. Corrective measure must be taken if it exceeds the limit.

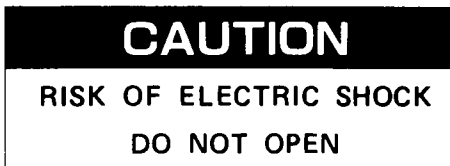
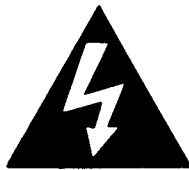

CAUTION: TO REDUCE THE RISK OF ELECTRIC SHOCK, DO NOT REMOVE COVER (OR BACK). NO USER SERVICEABLE PARTS INSIDE. REFER SERVICING TO QUALIFIED SERVICE PERSONNEL.



The lightning flash with arrowhead symbol within an equilateral triangle is intended to alert the user of the presence of uninsulated "dangerous voltage" within the product's enclosure that may be of sufficient magnitude to constitute a risk of electric shock to persons.



The exclamation point within an equilateral triangle is intended to alert the user of the presence of important operating and maintenance (servicing) instructions in the literature accompanying the appliance.