

DENON

Hi-Fi Component Amplifier

SERVICE MANUAL MODEL POA-8000 MONAURAL POWER AMPLIFIER

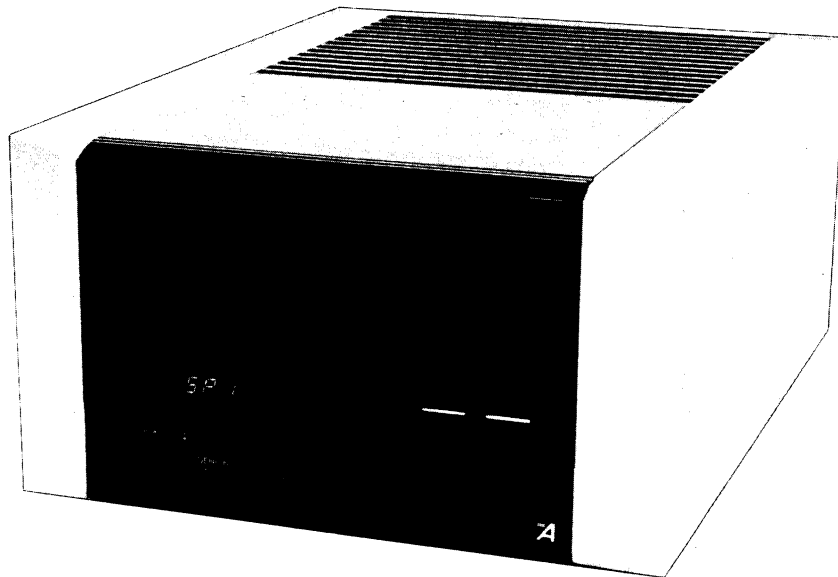

CONTENTS

SPECIFICATIONS	1
BLOCK DIAGRAM	1
METHOD OF ADJUSTMENT	2~4
PRINTED CIRCUIT BOARD PATTERNS AND PARTS LIST	
DRIVE UNIT ETC-422	5~7
CANCELER UNIT ETC-425	8,9
METER LAMP UNIT ETC-428-1, LAMP (R) ETC-428-2, LAMP (L) ETC-427-3	9
POWER OUT (A) UNIT ETC-423	10
POWER OUT (B) UNIT ETC-424	10,11
METER & PROTECTOR UNIT ETC-426	11,12
INPUT UNIT ETC-427-1, RELAY UNIT ETC-427-2, LED UNIT ETC-429	13
POWER SUPPLY UNIT SUX-028	14,15
TROUBLESHOOTING	15
WIRING DIAGRAM	16
EXPLODED VIEW OF CHASSIS AND CABINET	17
PARTS LIST OF EXPLODED VIEW	17

NIPPON COLUMBIA CO., LTD.

SPECIFICATIONS

POWER AMPLIFIER SECTION CHARACTERISTICS

Music Output: (8 ohm load) . . . 320 W
Rated Output: (Sinusoidal Output 20 Hz to 20 kHz)
 . . . 200 W / 8 ohm

Total Harmonic Distortion Factor: 20 Hz to 20 kHz . . . 0.003%
 200 Watts at 8 ohms 20 Hz ~ 20 kHz
 with no More Than 0.005% Total
 Harmonic Distortion (U.S.A.)

Input Sensitivity/
Input Impedance: 1 V / 50 k ohm
Output Impedance: 0.1 ohm
S/N Ratio: 120 dB (IHF "A")
Transmission
Characteristic: 1 Hz to 100 kHz $^{+0}_{-1}$ dB
Subsonic Filter
Characteristic: 16 Hz 6 dB/OCT
Slew Rate: ± 380 V/ μ sec

LEVEL METER CHARACTERISTICS

Type of Indication: Output level peak indication (with rated
 peak output holding display function)

Indicating Range: -50 dB to +5 dB = 200 W / 8 ohm

Frequency Characteristic: 10 Hz to 100 kHz ± 3 dB

DIGITAL DISPLAY FUNCTIONS

Muting Display: Counting down from Initial value 7 to 0

Speaker Display: SP1 or SP2

Self-Diagnostic Function: Diagnostic functions for main and distortion
 elimination circuits; and for abnormal high temperature inside the unit

GENERAL

Power Source: AC 220 V, 50 Hz (Germany and France)
 AC 240 V, 50 Hz (U.K.)
 AC 120 V, 60 Hz (U.S.A.)
 AC 200 V, 50 Hz (Hong Kong)

Power Consumption: In nonsignaling generation, 160 W
 370 W (U.S.A.)
 VA (Canada)

820 W (at maximum output)

Dimensions: 310 (W) x 188 (H) x 462 (D) mm
 (including knob heights and leg height)

Weight: 22 kg

Specifications are subject to change for further improvements
 without notice.

BLOCK DIAGRAM

NOTE: The following codes correspond to the appropriate models.
 E3 for U.S.A., EC for Canada, E2 for Europe, EF for France, EG for Germany, EK for U.K., E1 for Hong Kong.
 This Service Manual is prepared based on E3.

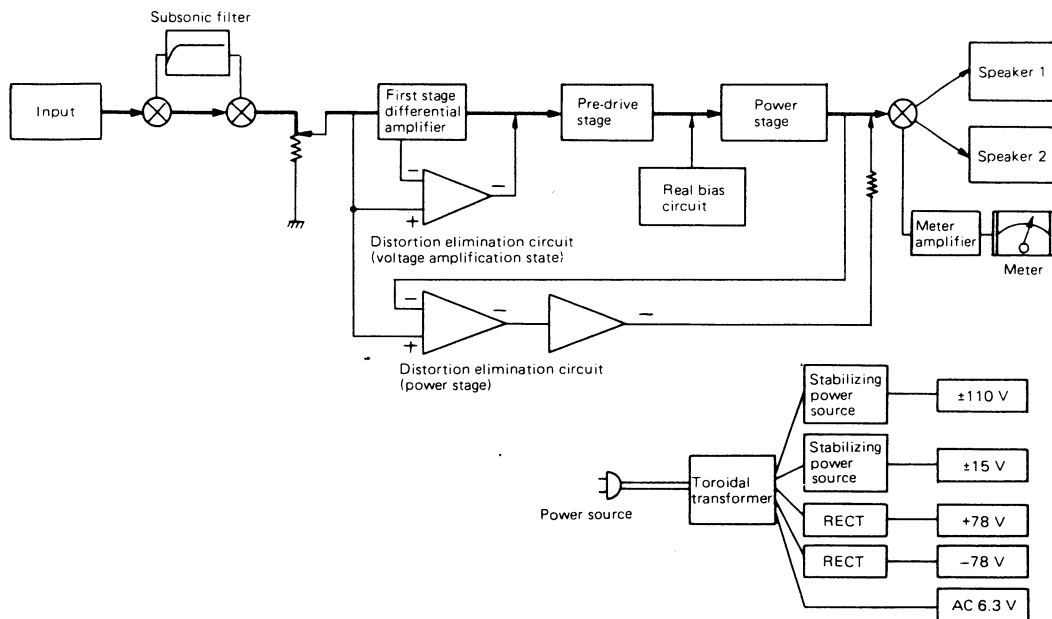

METHOD OF ADJUSTMENT

[1] Idling Current Adjustment

● Preparation

1. Detach top cover glass and ventilator.
2. Detach both Left and Right side panels.

● Switch and Control Setup

1. Set each switch as per,

Front Panel	Power switch	→	OFF
	Speaker switch	→	SP1
	Meter switch	→	Luminous side
Back Panel	Subsonic switch	→	OFF
	Level volume	→	MIN.

2. Connect digital voltmeter probe to TP-2 of power amplifier block ETC-0422 via chassis opening.
3. Prepare an adjusting screw driver to adjust VR-3 via back panel hole.
4. Connect another digital voltmeter to TP-1 of ETC-0422.
5. Turn Power switch ON and allow 3 minute warming up. First, adjust VR-1 so as digital voltmeter which is connected to TP-1, indicates $14.5 \pm 0.5V$.
Then adjust VR-3 so as digital voltmeter which is connected to TP-2 indicates 160mV.
6. After the main amplifier adjustment, connect a digital voltmeter to TP-1 of Distortion eliminator circuit ETC-0425, and adjust VR-1 so as the meter indicates 7 ~ 8.5mV. Allow idling time (time elapse after Power switch turned ON) before the adjustment referring to a table below.

Elapse time (minute)	Adjustment value (mV)
3	7
4	8.5
5	9.4
after 6	10.0

Precaution:

A certain digital voltmeter which is connected to TP-1 may invite oscillation.

[2] Meter Adjustment

● Preparation

1. Detach top cover glass, ventilator and both left and right panels.
Detach front panel assembly to adjust 0 point of the meter.

● Setup

1. Connect an 8 ohm load resistor (about 250W, or allow suitable heat dissipation) and a VTVM to measure output level across SP-1 terminals.
2. Apply 1 kHz sinusoidal signal to input terminal. First, set the Attenuator of generator to 0dB, and then adjust the level with VR.
3. Set each switch as per,

Front panel	1. Power switch	→	OFF
	2. Speaker switch	→	SP1
	3. Meter switch	→	Luminous side
4. Meter Adjustment
 - a) Turn Power switch ON and set input level to MIN, and adjust 0 point setting knob to center the pointer of the Front meter.

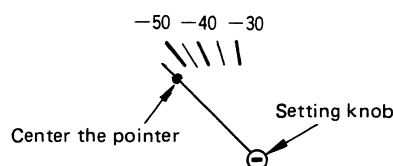

- b) Increase input signal level so as the output level indicates 40V. Then adjust VR2 of meter PCB assembly ETC-0426 so as the meter indicates 0dB.
- c) Adjust lighting level of peak indicator LED with VR1 of meter unit ETC-0426. Adjust VR1 slowly so as the LED turns OFF → ON (quickly brighten).

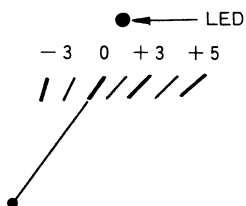

- d) Set ATT to -10dB, and check meter indicates -10 ± 1.5 dB.
 - e) Set ATT to -20dB, and check meter indicates -20 ± 3 dB.
 - f) Set ATT to -30dB, and check meter indicates -30 ± 3 dB.
 - g) Set ATT to -40dB, and check meter indicates -40 ± 3 dB.
5. Non-load Detector Circuit Adjustment
- a) Set output level to 20V/1 kHz.
 - b) Push Speaker selection switch to select SP-2 (non-load state). Adjust VR-3 of meter unit ETC-0426 so as a Relay of Distortion eliminator circuit ETC-0425 actuates after 3 seconds.

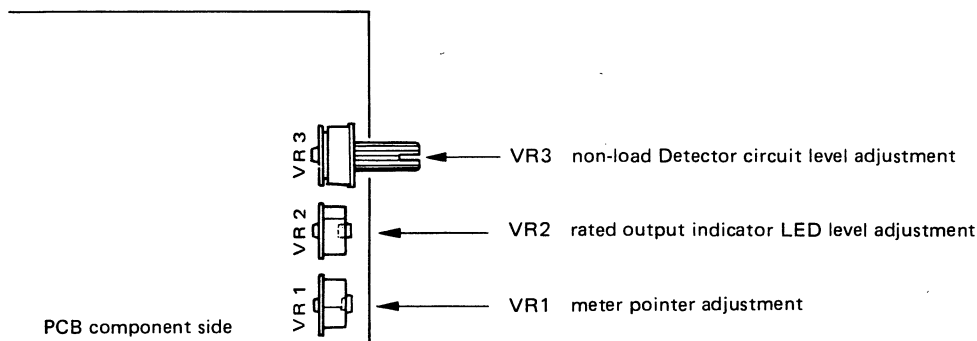

[3] Distortion Adjustment must be done after the service finished

● Preparation

1. Detach top cover glass and ventilator.
2. Detach both left and right side panels.

● Setup

1. Set each switch as per

Front panel	Power switch	→	OFF
	Speaker switch	→	SP-1
	Meter switch	→	Luminous side
Back panel	Subsonic switch	→	OFF
	Main volume control	→	MIN.

2. Terminate SP-1 terminals with 8 ohm resistor load, and apply generator output to input terminals.
3. Connect Distortion meter across the 8 ohm resistor.
4. Couple a current probe sensing terminal to current probe test terminal of Distortion eliminator circuit assembly ETC-0425.

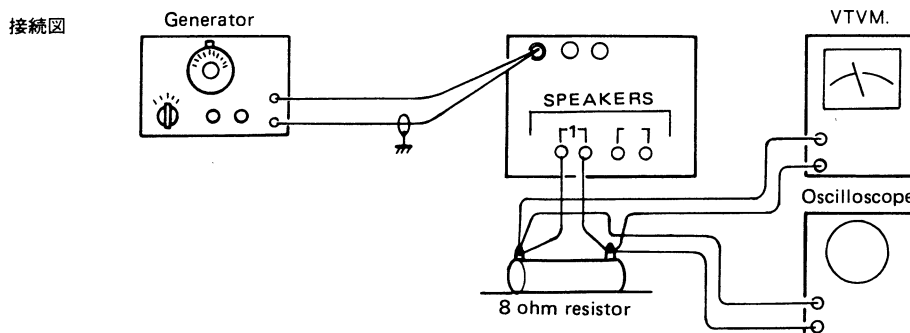

Ref. No.	Part No.	Part Name & Descriptions
R05	2452013014	100 kohm±1% ¼W METAL OXIDE COMPOSIT
R08	2452013014	100 kohm±1% ¼W METAL OXIDE COMPOSIT
R10	2412320004	11 kohm ±2% ¼W CARBON FILM
R11	2412320004	11 kohm ±2% ¼W CARBON FILM
R13	2440017020	10 ohm ±5% 1W METAL OXIDE FILM
R19	2440017020	10 ohm ±5% 1W METAL OXIDE FILM
R23	2440029021	100 ohm ±5% 1W METAL OXIDE FILM
R24	2440029021	100 ohm ±5% 1W METAL OXIDE FILM
R27	2440029021	100 ohm ±5% 1W METAL OXIDE FILM
R28	2440029021	100 ohm ±5% 1W METAL OXIDE FILM
CAPACITORS		
C01	2544051005	220µF 50V ELECTROLYTIC
C02	2544051005	220µF 50V ELECTROLYTIC
C03	2544028009	100µF 25V ELECTROLYTIC
C04	2544028009	100µF 25V ELECTROLYTIC
C05	2544044009	1µF 50V ELECTROLYTIC
C06	2556075008	100pF ±5% 50V PLASTIC FILM
C07	2544044009	1µF 50V ELECTROLYTIC
C08	2561017019	0.01µF ±10% 630V METALIZED
C12	2561018005	10µF ±10% 250V METALIZED
C13	2561018005	10µF ±10% 250V METALIZED
C14	2544156007	100µF 160V ELECTROLYTIC
C15	2544156007	100µF 160V ELECTROLYTIC
C16	2561014041	0.1µF ±10% 250V METALIZED
C17	2561014041	0.1µF ±10% 250V METALIZED
C18	2556152015	150pF ±5% 250V PLASTIC FILM
C19	2556152015	150pF ±5% 250V PLASTIC FILM
C20	2521014007	15pF ±5% 50V MICA FILM
C21	2521014007	15pF ±5% 50V MICA FILM
C22	2546057007	470µF ±20% 160V ELECTROLYTIC
C23	2546057007	470µF ±20% 160V ELECTROLYTIC
C24	2561018005	10µF 250V METALIZED
C25	2561018005	10µF 250V METALIZED

Ref. No.	Part No.	Part Name & Descriptions
RELAY		
RL01	2140035001	RELAY FOR LAMP
RL02	2140038008	RELAY FOR LAMP SW.
FUSE		
F01	2061035038	FUSE (6.3A)
F02	2061035009	FUSE (3.15AT)
F03	2061035009	FUSE (3.15AT)
F04	2061035038	FUSE (6.3A)
F05	206	FUSE (8ATL)
OTHER PARTS		
	2220749107	P.W. BOARD
	2090008117	JUMPER P=12.5mm
	2050122020	2P CONNECTOR PIN ASS'Y
	2050122033	3P CONNECTOR PIN ASS'Y
	2050122059	5P CONNECTOR PIN ASS'Y
	2035622008	3P CONNECTOR BASE
	2050087039	3P TERMINAL
	2050087042	4P TERMINAL
	4170078201	RADIATOR
	4700011007	CROSS PAN SCREW WITH S.WASHER 3x10
	4150052001	INST. SHEET (AC-229)
	4150192000	BUSH (YC20A)
	4751003006	WASHER φ3
	4756006008	NUT M3
	4730454016	TAPPING SCREW (2) 4x8
	2020014003	FUSE CLIP
	EP-5870	FUSE HOLDER
	2030226001	1P CONTACT ASS'Y
		USED 5
		USED 2
		USED 2
		USED 8
		USED 2

TROUBLESHOOTING

1. Are all connections proper?
2. Did you follow the operating instructions?
3. Do the speakers and the premain amplifier operate properly?

When Model POA-8000 does not operate properly, follow the procedures according to the flow chart below. If the trouble does not correspond to the items of the flow chart, turn off the power switch because POA-8000 may be broken. Contact the shop where you purchased the unit.

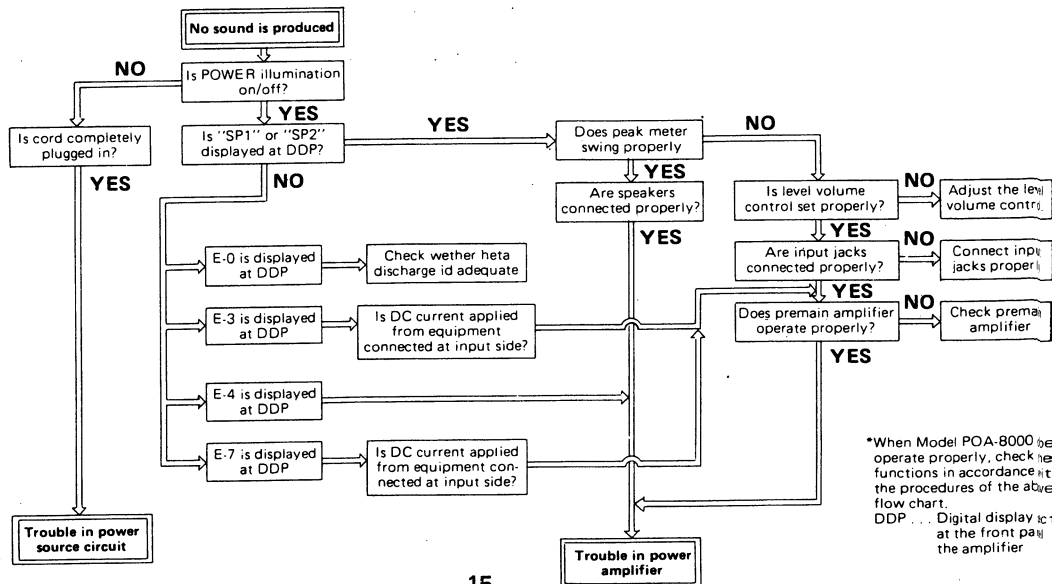

*When Model POA-8000 does not operate properly, check the functions in accordance with the procedures of the above flow chart.
DDP: Digital display position at the front panel of the amplifier

SUX-028 POWER SUPPLY UNIT

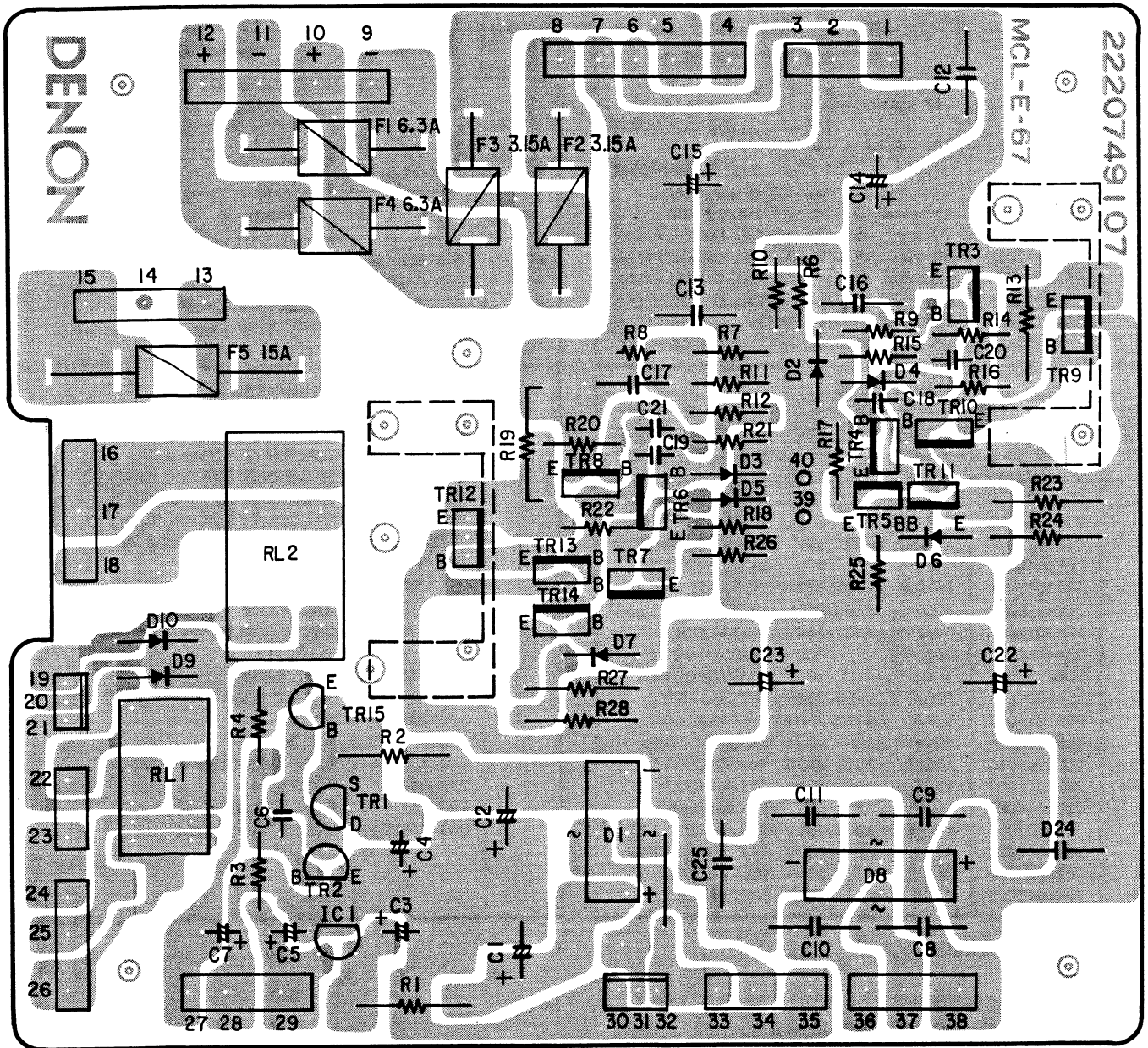

SUX-0028 POWER SUPPLY UNIT

Ref. No.	Part No.	Part Name & Descriptions	
SEMICONDUCTORS			
IC01	2680031002	TA78L015P	INTEGRATED CIRCUIT
TR01	2750018010	2SK30A(O)	FIELD EFFECT TRANSISTOR
TR02	2710102005	2SA1015(Y)	TRANSISTOR
TR03	2730205005	2SC1941(L)	TRANSISTOR
TR04	2730205005	2SC1941(L)	TRANSISTOR
TR05	2730205005	2SC1941(L)	TRANSISTOR
TR06	2710110000	2SA916(L)	TRANSISTOR
TR07	2710110000	2SA916(L)	TRANSISTOR
TR08	2710110000	2SA916(L)	TRANSISTOR
TR09	2730199027	2SC2238(Y)/(O)	TRANSISTOR
TR10	2730205005	2SC1941(L)	TRANSISTOR
TR11	2710110000	2SA916(L)	TRANSISTOR
TR12	2710104029	2SA968(Y)/(O)	TRANSISTOR
TR13	2710110000	2SA916(L)	TRANSISTOR
TR14	2730205005	2SC1941(L)	TRANSISTOR

Ref. No.	Part No.	Part Name & Descriptions	
TR15	2710117003	2SA1020(Y)	TRANSISTOR
D01	2760194018	S1RBA10F	DIODE
D02	2760049008	1S2076	DIODE
D03	2760049008	1S2076	DIODE
D04	2760254000	HZ7B-3	DIODE
D05	2760254000	HZ7B-3	DIODE
D06	2760049008	1S2076	DIODE
D07	2760049008	1S2076	DIODE
D08	2760245006	S1RBA40F	DIODE
D09	2760049008	1S2076	DIODE
D10	2760049008	1S2076	DIODE
RESISTORS (not included ±5%, ¼W, Carbon Film Type)			
R01	2440034029	270 ohm ±5% 1W	METAL OXIDE FILM
R02	2440035028	330 ohm ±5% 1W	METAL OXIDE FILM

ETC-427-1 INPUT UNIT

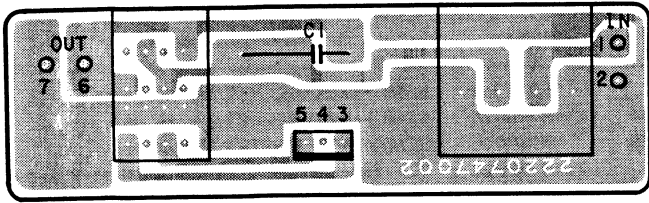

ETC-427-1 INPUT UNIT PARTS LIST

Ref. No.	Part No.	Part Name & Descriptions
GENERAL		
C01	2551134054	0.1μF ±5% 50V PLASTIC FILM
SW01	2120155008	ROTARY SWITCH (4-2)
VR01	2110228107	VARIABLE RESISTOR 100 kohm
	2220747002	P.W. BOARD
	2035622008	3P CONNECTOR BASE
	2034170001	3P CONNECTOR CORD

ETC-427-2 RELAY UNIT

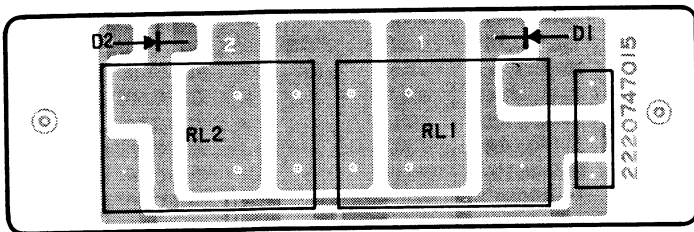

ETC-427-2 RELAY UNIT PARTS LIST

Ref. No.	Part No.	Part Name & Descriptions
SEMICONDUCTORS		
D01	2760049008	1S2076 DIODE
D02	2760049008	1S2076 DIODE
OTHER PARTS		
RL01	2140041008	RELAY
RL02	2140041008	RELAY
	2220747015	P.W. BOARD
	2050122033	3P CONNECTOR PIN ASS'Y

ETC-427-3 LED UNIT

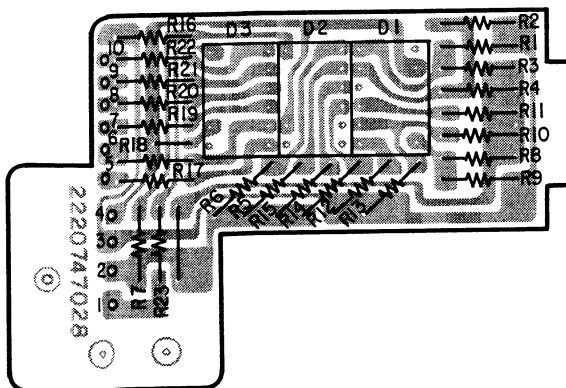

ETC-427-3 LED UNIT PARTS LIST

Ref. No.	Part No.	Part Name & Descriptions
SEMICONDUCTORS		
D01	3939143006	LN513GKS LIGHT EMITTING DIODE
D02	3939143006	LN513GKS LIGHT EMITTING DIODE
D03	3939143006	LN513GKS LIGHT EMITTING DIODE
RESISTORS (not included ±5%, ¼W, Carbon Film Type)		
OTHER PARTS		
	2220747028	P.W. BOARD
	2090008146	JUMPER P=5mm
	2090008120	JUMPER P=10mm
	2042037000	10P CONNECTOR CORD
	4450033005	WIRE CLAMP BAND

ETC-426 METER & PROTECTOR UNIT PARTS LIST

Ref. No.	Part No.	Part Name & Descriptions	
SEMICONDUCTORS			
IC01	262030007	HD14011BP	INTEGRATED CIRCUIT
IC02	2620338008	HD14510BP	INTEGRATED CIRCUIT
IC03	2620303004	HD14075BP	INTEGRATED CIRCUIT
IC04	2620339007	HD14511BP	INTEGRATED CIRCUIT
IC05	2620298009	HD14001BP	INTEGRATED CIRCUIT
IC06	2630071009	TA-7318P	INTEGRATED CIRCUIT
IC07	2620298009	HD14001BP	INTEGRATED CIRCUIT
IC08	2620310000	HD145388BP	INTEGRATED CIRCUIT
IC09	2630118001	NJM4560D	INTEGRATED CIRCUIT
TR01	2730198015	2SC1815(BL)	TRANSISTOR
TR02	2730198015	2SC1815(BL)	TRANSISTOR
TR03	2710102005	2SA1015(Y)	TRANSISTOR
TR04	2730198015	2SC1815(BL)	TRANSISTOR
TR05	2730198015	2SC1815(BL)	TRANSISTOR
TR06	2730198015	2SC1815(BL)	TRANSISTOR
TR07	2730198015	2SC1815(BL)	TRANSISTOR
TR08	2730198015	2SC1815(BL)	TRANSISTOR
TR09	2730198015	2SC1815(BL)	TRANSISTOR
TR10	2730198015	2SC1815(BL)	TRANSISTOR
TR12	2730198015	2SC1815(BL)	TRANSISTOR
TR13	2730198015	2SC1815(BL)	TRANSISTOR
TR14	2730212001	2SC2655(Y)	TRANSISTOR
TR15	2730198015	2SC1815(BL)	TRANSISTOR
TR16	2730198015	2SC1815(BL)	TRANSISTOR
TR17	2730198015	2SC1815(BL)	TRANSISTOR
TR18	2730177007	2SC1626(Y)	TRANSISTOR
TR20	2730198015	2SC1815(BL)	TRANSISTOR
TR21	2730198015	2SC1815(BL)	TRANSISTOR
TR22	2730198015	2SC1815(BL)	TRANSISTOR
TR23	2710102005	2SA1015(Y)	TRANSISTOR
TR24	2730198015	2SC1815(BL)	TRANSISTOR
TR25	2710102005	2SA1015(Y)	TRANSISTOR
TR26	2710102005	2SA1015(Y)	TRANSISTOR
D01	2760151006	1D2C-1	DIODE
D02	2760049011	1S2076A	DIODE
D03	2760049011	1S2076A	DIODE
D04	2760049008	1S2076	DIODE
D05	2760049008	1S2076	DIODE
D06	2760049008	1S2076	DIODE
D07	2760049008	1S2076	DIODE
D08	2760049008	1S2076	DIODE
D09	2760049008	1S2076	DIODE
D10	2760220018	HZ24-1	DIODE
D11	2760254000	HZ7B-3	DIODE
D12	2760049008	1S2076	DIODE
D13	2760049008	1S2076	DIODE
D14	2760049008	1S2076	DIODE
D15	2760049008	1S2076	DIODE
D16	2760049008	1S2076	DIODE
D17	2760049008	1S2076	DIODE
D18	2760049008	1S2076	DIODE
D19	2760049008	1S2076	DIODE
D21	2760049008	1S2076	DIODE
D22	2760049008	1S2076	DIODE
D23	2760049008	1S2076	DIODE
D24	2760049008	1S2076	DIODE
RESISTORS (not included 1/4W, ±5% Carbon Film Type)			
VR01	2116031013	SEMI FIXED RESISTOR 1 kohm	
VR02	2116031000	SEMI FIXED RESISTOR 500 ohm	

Ref. No.	Part No.	Part Name & Descriptions		
VR03	2116010076	SEMI FIXED RESISTOR 1k ohm		
VR04	2116016025	SEMI FIXED RESISTOR 5k ohm		
VR05	2116016025	SEMI FIXED RESISTOR 5k ohm		
R09	2440030023	120 ohm ±5% 1W METAL OXIDE FILM		
R16	2420203003	10 Mohm ±10% 1/4W CARBON COMPOSIT		
R17	2420195001	2.2 Mohm ±10% 1/4W CARBON COMPOSIT		
R30	2440035028	330 ohm ±5% 1W METAL OXIDE FILM		
R33	2440089029	180 ohm ±5% 2W METAL OXIDE FILM		
R37	2440030023	120 ohm ±5% 1W METAL OXIDE FILM		
R51	2440041025	1 kohm ±5% 1W METAL OXIDE FILM		
R62	2790006011	112101-2 THERMISTOR		
R63	2790006011	112101-2 THERMISTOR		
R64	2440032021	180 ohm ±5% 1W METAL OXIDE FILM		
CAPACITORS				
C01	2544041002	470μF	35V	ELECTROLYTIC
C02	2544060038	0.47μF	160V	ELECTROLYTIC
C03	2544034006	4.7μF	35V	ELECTROLYTIC
C04	2561008028	0.22μF	±10% 100V	METALIZED
C05	2554137003	470pF	±5% 50V	PLASTIC FILM
C06	2544054002	22μF	16V	ELECTROLYTIC
C07	2544003008	100μF	63V	ELECTROLYTIC
C08	3544003008	100μF	63V	ELECTROLYTIC
C10	2544054002	22μF	16V	ELECTROLYTIC
C11	2544035005	10μF	35V	ELECTROLYTIC
C12	2544003008	100μF	6.3V	ELECTROLYTIC
C13	2544044009	1μF	50V	ELECTROLYTIC
C14	2544044009	1μF	50V	ELECTROLYTIC
C15	2544044009	1μF	50V	ELECTROLYTIC
C16	2544043000	0.47μF	50V	ELECTROLYTIC
C17	2561008028	0.22μF	±10% 100V	METALIZED
C18	2554080024	0.022μF	±5% 100V	PLASTIC FILM
C19	2544009002	47μF	10V	ELECTROLYTIC
C21	2521034003	100pF	±5% 50V	MICA FILM
C22	2544044009	1μF	50V	ELECTROLYTIC
C23	2544044009	1μF	50V	ELECTROLYTIC
C24	2549011008	1μF	50V	ELECTROLYTIC
C25	2549022013	4.7μF	25V	ELECTROLYTIC(LR)
C26	2521034003	100pF	±5% 50V	MICA FILM
OTHER PARTS				
	2220746100	P.W. BOARD		
	2090008120	JUMPER P=10mm		USED 34
	2090008117	JUMPER P=12.5mm		USED 5
	2030203011	10P CONNECTOR BASE		
	2030203053	5P CONNECTOR BASE		
	2035634009	3P CONNECTOR BASE		
	2034165003	3P CONNECTOR CORD		
	2034165016	3P CONNECTOR CORD		
	2034165029	3P CONNECTOR CORD		
	2034165032	3P CONNECTOR CORD		
	2034165045	3P CONNECTOR CORD		
	2034165058	3P CONNECTOR CORD		
	2034166002	3P CONNECTOR CORD		
	2040081003	6P CONNECTOR CORD		

ETC-424 POWER OUT (B) UNIT PARTS LIST

Ref. No.	Part No.	Part Name & Descriptions
SEMICONDUCTORS		
D02	2760184002	1S1834 DIODE
D04	2760184002	1S1834 DIODE
RESISTORS		
R27	2432036006	0.82 ohm ±5% 3.15W WIRE WOUND
R28	2432036006	0.82 ohm ±5% 3.15W WIRE WOUND
R29	2432036006	0.82 ohm ±5% 3.15W WIRE WOUND
R30	2432036006	0.82 ohm ±5% 3.15W WIRE WOUND
R31	2432036006	0.82 ohm ±5% 3.15W WIRE WOUND
R32	2432036006	0.82 ohm ±5% 3.15W WIRE WOUND
R33	2442007038	100 ohm ±5% ¼W METAL OXIDE FILM
R34	2442007038	100 ohm ±5% ¼W METAL OXIDE FILM
R35	2442022000	1 kohm ±5% ¼W METAL OXIDE FILM
R36	2442022000	1 kohm ±5% ¼W METAL OXIDE FILM
R37	2442022000	1 kohm ±5% ¼W METAL OXIDE FILM
R38	2442022000	1 kohm ±5% ¼W METAL OXIDE FILM
R39	2442022000	1 kohm ±5% ¼W METAL OXIDE FILM
R40	2442022000	1 kohm ±5% ¼W METAL OXIDE FILM
R41	2442022000	1 kohm ±5% ¼W METAL OXIDE FILM
R42	2442022000	1 kohm ±5% ¼W METAL OXIDE FILM
R43	2442022000	1 kohm ±5% ¼W METAL OXIDE FILM
R44	2442022000	1 kohm ±5% ¼W METAL OXIDE FILM

Ref. No.	Part No.	Part Name & Descriptions
R45	2442022000	1 kohm ±5% ¼W METAL OXIDE FILM
R46	2442022000	1 kohm ±5% ¼W METAL OXIDE FILM
R47	2412322002	10 ohm ±5% ¼W CARBON FILM FUSIBLE
R48	2412322002	10 ohm ±5% ¼W CARBON FILM FUSIBLE
R49	2412322002	10 ohm ±5% ¼W CARBON FILM FUSIBLE
R50	2412322002	10 ohm ±5% ¼W CARBON FILM FUSIBLE
R51	2412322002	10 ohm ±5% ¼W CARBON FILM FUSIBLE
R52	2412322002	10 ohm ±5% ¼W CARBON FILM FUSIBLE
CAPACITOR		
C02	EP-7355	1µF 160V ELECTROLYTIC (HR)
OTHER PARTS		
	2220744018	P.W. BOARD
	EP-5667H1	TERMINAL
	2050141001	COMMON PLATE
		USED 2
		USED 2

ETC-426 METER & PROTECTOR UNIT

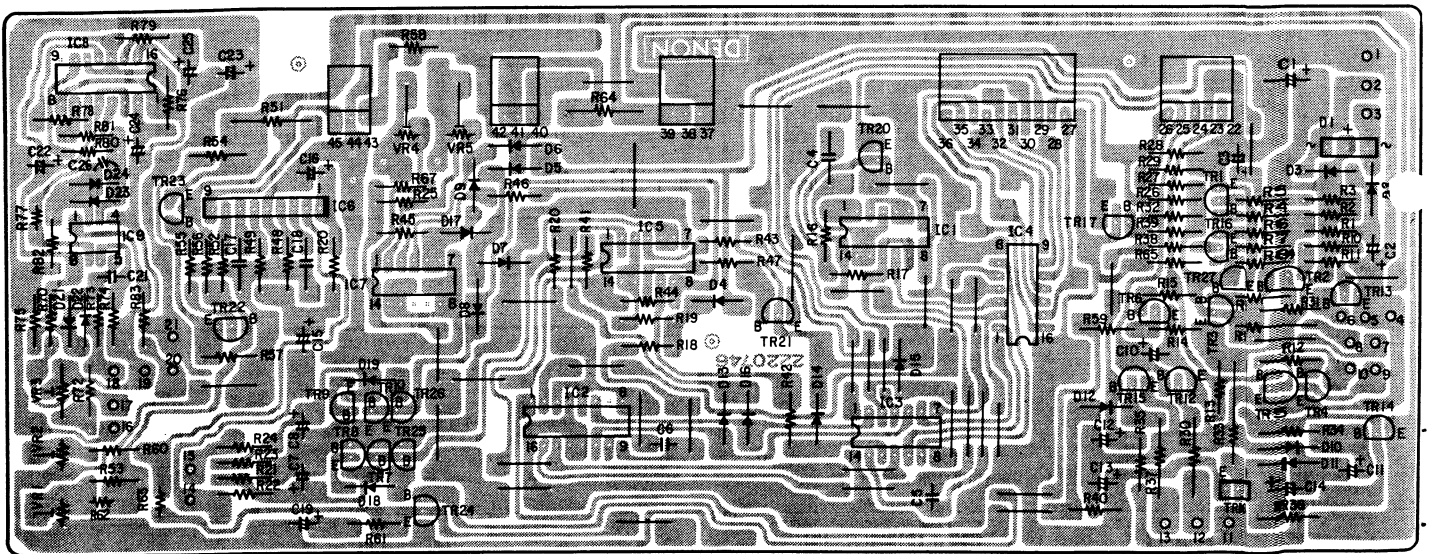

ETC-423 POWER OUT (A) UNIT

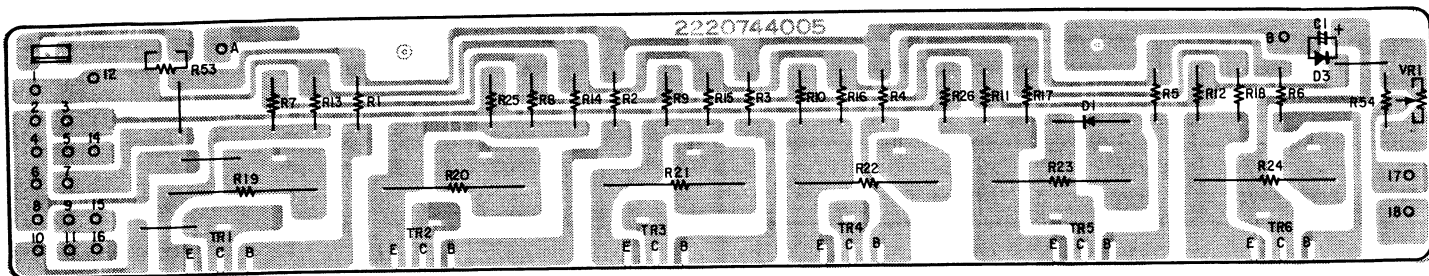

ETC-423 POWER OUT (A) UNIT PARTS LIST

Ref. No.	Part No.	Part Name & Descriptions	
SEMICONDUCTORS			
D01	2760184002	1S1834	DIODE
D02	2760184002	1S1834	DIODE
D03	2760184002	1S1834	DIODE
D04	2760184002	1S1834	DIODE
RESISTORS			
R01	2412322002	10 ohm ±5% ¼W	CARBON FILM FUSIBLE
R02	2412322002	10 ohm ±5% ¼W	CARBON FILM FUSIBLE
R03	2412322002	10 ohm ±5% ¼W	CARBON FILM FUSIBLE
R04	2412322002	10 ohm ±5% ¼W	CARBON FILM FUSIBLE
R05	2412322002	10 ohm ±5% ¼W	CARBON FILM FUSIBLE
R06	2412322002	10 ohm ±5% ¼W	CARBON FILM FUSIBLE
R07	2442022000	1 kohm ±5% ¼W	METAL OXIDE FILM
R08	2442022000	1 kohm ±5% ¼W	METAL OXIDE FILM
R09	2442022000	1 kohm ±5% ¼W	METAL OXIDE FILM
R10	2442022000	1 kohm ±5% ¼W	METAL OXIDE FILM
R11	2442022000	1 kohm ±5% ¼W	METAL OXIDE FILM
R12	2442022000	1 kohm ±5% ¼W	METAL OXIDE FILM
R13	2442022000	1 kohm ±5% ¼W	METAL OXIDE FILM
R14	2442022000	1 kohm ±5% ¼W	METAL OXIDE FILM
R15	2442022000	1 kohm ±5% ¼W	METAL OXIDE FILM

Ref. No.	Part No.	Part Name & Descriptions	
R16	2442022000	1 kohm ±5% ¼W	METAL OXIDE FILM
R17	2442022000	1 kohm ±5% ¼W	METAL OXIDE FILM
R18	2442022000	1 kohm ±5% ¼W	METAL OXIDE FILM
R19	2432036006	0.82 ohm ±5% 3.15W	WIRE WOUND
R20	2432036006	0.82 ohm ±5% 3.25W	WIRE WOUND
R21	2432036006	0.82 ohm ±5% 3.15W	WIRE WOUND
R22	2432036006	0.82 ohm ±5% 3.15W	WIRE WOUND
R23	2432036006	0.82 ohm ±5% 3.15W	WIRE WOUND
R24	2432036006	0.82 ohm ±5% 3.15W	WIRE WOUND
R25	2442007038	100 ohm ±5% ¼W	METAL OXIDE FILM
R26	2442007038	100 ohm ±5% ¼W	METAL OXIDE FILM
R53	2760289004	PTH487A01BD222TS	
R54	2412044005	10 ohm ±5% ¼W	CARBON FILM
CAPACITOR			
C01	EP-7355	1µF	160V ELECTROLYTIC (HR)
OTHER PARTS			
VR01	2220744005	P.W. BOARD	
	EP-5667H1	TERMINAL	USED 2
	2090008120	JUMPER P=10mm	USED 4
	2116014001	SEMI FIXED RESISTOR 100 OHM	
	2050141001	COMMON PLATE	USED 2
	2034170001	3P CONNECTOR CORD	
	2036090008	4P CONNECTOR CORD	
	2038099007	5P CONNECTOR CORD	
2035622008	3P CONNECTOR BASE		

ETC-424 POWER OUT (B) UNIT

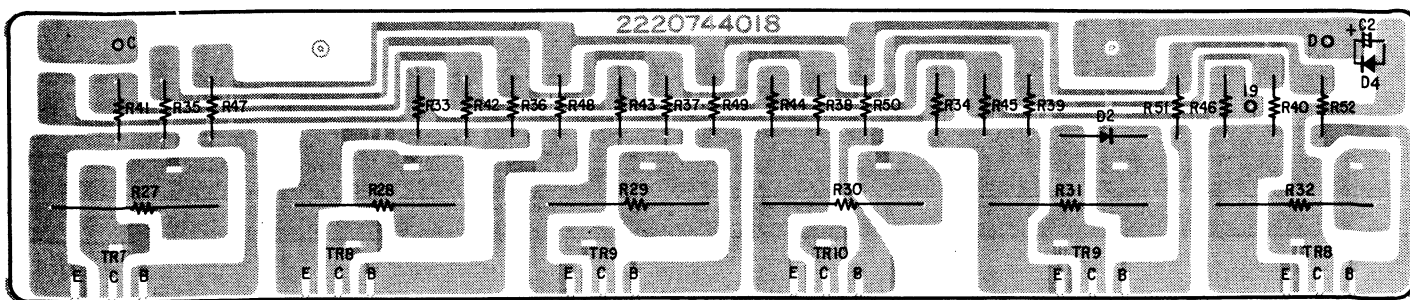

Ref. No.	Part No.	Part Name & Descriptions
CAPACITORS		
C01	2521018003	22pF ±5% 50V MICA FILM
C02	2554145008	0.001μF ±5% 50V PLASTIC FILM
C03	2561008060	1μF ±10% 100V METALIZED
C04	2521010001	10pF ±0.5pF 50V MICA FILM
C05	2521026008	47pF ±5% 50V MICA FILM
C06	2544044009	1μF 50V ELECTROLYTIC
C07	2554145008	0.001μF ±5% 50V PLASTIC FILM
C08	2544155011	10μF 160V ELECTROLYTIC
C09	2544155011	10μF 160V ELECTROLYTIC
C10	2544155008	10μF 160V ELECTROLYTIC
C11	2544060009	10μF 100V ELECTROLYTIC
C12	2544060025	1μF 100V ELECTROLYTIC
C13	2554161008	0.0047μF ±5% 50V PLASTIC FILM
C14	2554161008	0.0047μF ±5% 50V PLASTIC FILM
C15	2554161008	0.0047μF ±5% 50V PLASTIC FILM
C16	2544044009	1μF 50V ELECTROLYTIC
C17	2554161008	0.0047μF ±5% 50V PLASTIC FILM
C18	2544060009	10μF 100V ELECTROLYTIC
C20	2544060025	1μF 100V ELECTROLYTIC
C21	2544155008	1μF 160V ELECTROLYTIC
C22	2561017035	0.022μF ±10% 630V METALIZED
C23	2561017019	0.01μF ±10% 630V METALIZED
C31	2554081081	0.1μF ±5% 100V PLASTIC FILM

Ref. No.	Part No.	Part Name & Descriptions
RELAY, COILS		
L01	2350004000	INDUCTOR (0.9μH)
L02	2350005009	INDUCTOR (0.05mH)
L03	2350004000	INDUCTOR (0.9μH)
RL01	2140041008	RELAY
OTHER PARTS		
	2220745101	P.W. BOARD
	2090008120	JUMPER P=10mm USED 6
	2090008133	JUMPER P=7.5mm
	4140240001	EARTH PLATE
	2050122033	3P CONNECTOR PIN ASS'Y
	2035622008	3P CONNECTOR BASE USED 6
	2035622082	6P CONNECTOR BASE
	2050087026	2P TERMINAL
	4700042050	CROSS PAN SCREW WITH SWASHER 3x30
	SC-10822	NUT-WASHER
	4140252002	SHIELD PLATE
	4170043100	RADIATOR
	4730354035	TAPPING SCREW (2) 3x8
	2030166019	CONNECTOR BASE USED 4
	2030224003	1P CONTACT ASS'Y
	2034174009	3P CONNECTOR CORD
	2034174010	3P CONNECTOR CORD

ETC-428-1 METER LAMP, ETC-428-2 LAMP (L), ETC-428-3 LAMP (R) UNIT

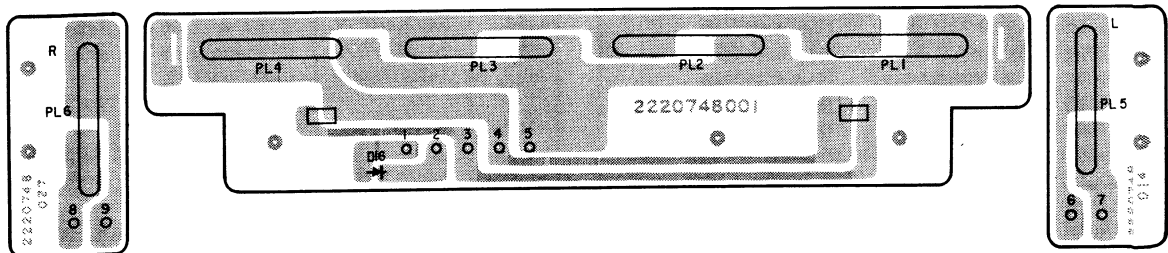

ETC-428-1 METER LAMP UNIT PARTS LIST

Ref. No.	Part No.	Part Name & Descriptions
SEMICONDUCTOR		
D16	3939051004	SEL1110R(RED) LIGHT EMITTING DIODE
GENERAL		
PL01 ~04	2220748001	P.W. BOARD
	2030203008	2P CONNECTOR BASE USED 2
	3930043008	PILOT LAMP
	2034146006	3P CONNECTOR CORD
	2034148020	3P CONNECTOR CORD
	4140241000	REFLECTOR

ETC-428-2 LAMP (L) UNIT PARTS LIST

Ref. No.	Part No.	Part Name & Descriptions
GENERAL		
PL05	2220748014	P.W. BOARD
	3930043008	PILOT LAMP
	2032089000	2P CONNECTOR CORD
	4120939002	BRACKET (L)
	4730353036	TAPPING SCREW 3x6 (MFN B)
	4140247004	LAMP COVER

ETC-428-3 LAMP (R) UNIT PARTS LIST

Ref. No.	Part No.	Part Name & Descriptions
GENERAL		
PL06	2220748027	P.W. BOARD
	3930043008	PILOT LAMP
	2032089000	2P CONNECTOR CORD
	4120939002	BRACKET (L)
	4730353036	TAPPING SCREW 3x6 (MFN B)
	4140247004	LAMP COVER

ETC-425 CANCELER UNIT

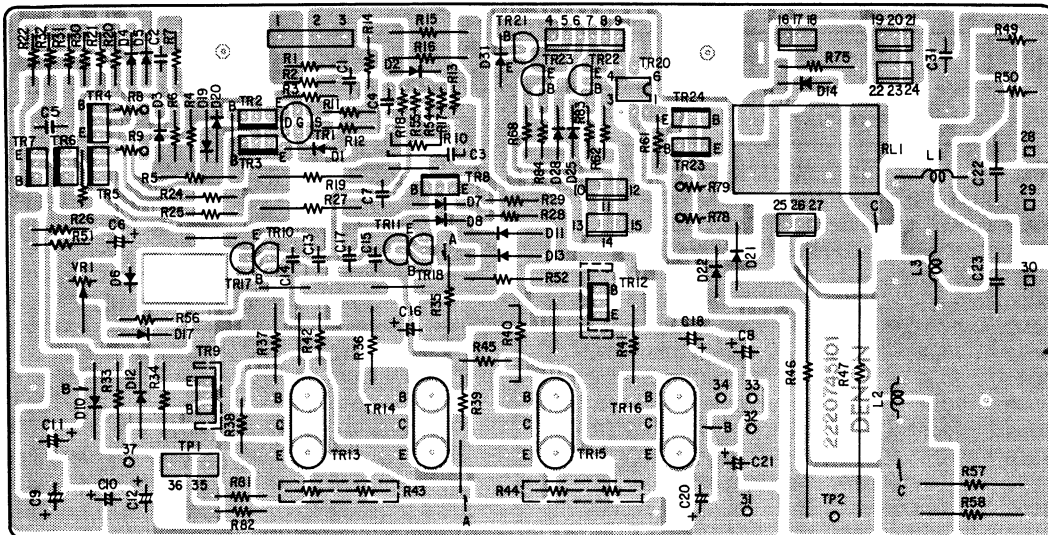

ETC-425 CANCELER UNIT PARTS LIST

Ref. No.	Part No.	Part Name & Descriptions	
SEMICONDUCTORS			
TR01	2750026044	2SK146(BL)	FIELD EFFECT TRANSISTOR
TR02	2730186001	2SC1940(L)	TRANSISTOR
TR03	2730186001	2SC1940(L)	TRANSISTOR
TR04	2730205005	2SC1941(L)	TRANSISTOR
TR05	2730205005	2SC1941(L)	TRANSISTOR
TR06	2710148001	2SA939(B)	TRANSISTOR
TR07	2710148001	2SA939(B)	TRANSISTOR
TR08	2730256009	2SC2071(B)	TRANSISTOR
TR09	2730259006	2SC2238B(Y)	TRANSISTOR
TR10	2730198002	2SC1815(Y)	TRANSISTOR
TR11	2710102005	2SA1015(Y)	TRANSISTOR
TR12	2710151001	2SA968B(Y)	TRANSISTOR
TR17	2710102005	2SA1015(Y)	TRANSISTOR
TR18	2730198002	2SC1815(Y)	TRANSISTOR
TR20	393902712	PC-613G	
TR21	2730198015	2SC1815(BL)	TRANSISTOR
TR22	2730198002	2SC1815(Y)	TRANSISTOR
TR23	2710102005	2SA1015(Y)	TRANSISTOR
TR24	2730199001	2SC2238(Y)	TRANSISTOR
TR25	2730205005	2SC1941(L)	TRANSISTOR
D01	2760254000	HZ7B-3	DIODE
D02	2760049008	1S2076	DIODE
D03	2760220021	HZ24-2	DIODE
D04	2760255012	HZ12A-1	DIODE
D05	2760255012	HZ12A-1	DIODE
D06	2760132038	STV-3H(YW)	DIODE
D07	2760049008	1S2076	DIODE
D08	2760049008	1S2076	DIODE
D09	2760049008	1S2076	DIODE
D10	2760184002	1S1834	DIODE
D11	2760184002	1S1834	DIODE
D12	2760184002	1S1834	DIODE
D13	2760184002	1S1834	DIODE
D14	2760049008	1S2076	DIODE
D17	2760171028	HV-23G(YW)	DIODE
D19	2760049008	1S2076	DIODE
D20	2760049008	1S2076	DIODE
D21	2760191008	W03C	DIODE
D22	2760254000	HZ7B-3	DIODE
D25	2760052053	HZ-11B-1	DIODE
D28	2760173000	HZ6A	DIODE
D31	2760049008	1S2076	DIODE

Ref. No.	Part No.	Part Name & Descriptions	
RESISTORS (not included $\pm 5\%$, $\frac{1}{4}W$, Carbon Film Type)			
VR01	2116016012	SEMI FIXED RESISTOR	500 ohm
R05	2442013051	27 kohm $\pm 5\%$ 1W	METAL OXIDE FILM
R10	2420203003	10 Mohm $\pm 10\%$ $\frac{1}{4}W$	CARBON COMPOSIT
R13	2452019061	220 ohm $\pm 1\%$ $\frac{1}{4}W$	METAL OXIDE COMPOSIT
R15	2440057022	22 kohm $\pm 5\%$ 1W	METAL OXIDE FILM
R16	2440057022	22 kohm $\pm 5\%$ 1W	METAL OXIDE FILM
R17	2452013009	0.0039 μF $\pm 1\%$ $\frac{1}{4}W$	METAL OXIDE COMPOSIT
R18	2452011056	0.0068 μF $\pm 1\%$ $\frac{1}{4}W$	METAL OXIDE COMPOSIT
R19	2440115029	0.027 μF $\pm 5\%$ 2W	METAL OXIDE FILM
R20	2412321029	1.5 kohm $\pm 5\%$ $\frac{1}{4}W$	CARBON FILM FUSIBLE
R24	2412321029	1.5 kohm $\pm 5\%$ $\frac{1}{4}W$	CARBON FILM FUSIBLE
R27	2440111023	12 kohm $\pm 5\%$ 2W	METAL OXIDE FILM
R28	2440049027	4.7 kohm $\pm 5\%$ 1W	METAL OXIDE FILM
R29	2440049027	4.7 kohm $\pm 5\%$ 1W	METAL OXIDE FILM
R30	2442013077	2 kohm $\pm 5\%$ 1W	METAL OXIDE FILM
R33	2440036027	390 ohm $\pm 5\%$ 1W	METAL OXIDE FILM
R34	2440027023	68 ohm $\pm 5\%$ 1W	METAL OXIDE FILM
R35	2440027023	68 ohm $\pm 5\%$ 1W	METAL OXIDE FILM
R36	2440017020	10 ohm $\pm 5\%$ 1W	METAL OXIDE FILM
R37	2440017020	10 ohm $\pm 5\%$ 1W	METAL OXIDE FILM
R40	2440017020	10 ohm $\pm 5\%$ 1W	METAL OXIDE FILM
R41	2440017020	10 ohm $\pm 5\%$ 1W	METAL OXIDE FILM
R43	2432033009	0.40/0.47 ohm $\pm 10\%$ 2W	WIRE WOUND
R44	2432033009	0.47/0.47 ohm $\pm 10\%$ 2W	WIRE WOUND
R46	2432034008	4 ohm $\pm 5\%$ 10W	WIRE WOUND
R47	2432034008	4 ohm $\pm 5\%$ 10W	WIRE WOUND
R49	2432035007	10 ohm $\pm 5\%$ 5W	WIRE WOUND
R50	2432035007	10 ohm $\pm 5\%$ 5W	WIRE WOUND
R52	2440036027	390 ohm $\pm 5\%$ 1W	METAL OXIDE FILM
R54	2452013009	3.9 kohm $\pm 1\%$ $\frac{1}{4}W$	METAL OXIDE COMPOSIT
R55	2452011056	6.8 kohm $\pm 1\%$ $\frac{1}{4}W$	METAL OXIDE COMPOSIT
R57	2440092029	330 ohm $\pm 5\%$ 2W	METAL OXIDE FILM
R58	2440091020	270 ohm $\pm 5\%$ 2W	METAL OXIDE FILM
R75	2440030023	120 ohm $\pm 5\%$ 1W	METAL OXIDE FILM
R78	2440114004	22 kohm $\pm 5\%$ 2W	METAL OXIDE FILM
R79	2440114004	22 kohm $\pm 5\%$ 2W	METAL OXIDE FILM

Ref. No.	Part No.	Part Name & Descriptions
R46	2452012068	560 ohm ±1% ¼W METAL OXIDE COMPOSIT
R54	2452013009	3.9 kohm ±1% ¼W METAL OXIDE COMPOSIT
R55	2452012055	470 ohm ±1% ¼W METAL OXIDE COMPOSIT
R63	2452019045	3.3 kohm ±1% ¼W METAL OXIDE COMPOSIT
R64	2420203003	10 Mohm ±10% ¼W CARBON COMPOSIT
R66	2452012071	1 kohm ±1% ¼W CARBON COMPOSIT
R74	2442013064	33 kohm ±5% 1W METAL OXIDE FILM
R75	2440107024	5.6 kohm ±5% 2W METAL OXIDE FILM
R87	2420203003	10 Mohm ±10% ¼W CARBON COMPOSIT
R92	2442013064	33 kohm ±5% 1W METAL OXIDE FILM
R93	2440107024	5.6 kohm ±5% 2W METAL OXIDE FILM
R102	2412313066	47 ohm ±2% ¼W CARBON FILM FUSIBLE
R103	2442013064	33 kohm ±5% 1W METAL OXIDE FILM
R106	2412313066	47 ohm ±2% ¼W CARBON FILM FUSIBLE
R107	2412315019	10 ohm ±2% ¼W CARBON FILM FUSIBLE
R108	2440031022	150 ohm ±5% 1W METAL OXIDE FILM
R109	2440028022	82 ohm ±5% 1W METAL OXIDE FILM
R110	2412315022	22 ohm ±2% ¼W CARBON FILM FUSIBLE
R111	2412315022	22 ohm ±2% ¼W CARBON FILM FUSIBLE
R112	2440028022	82 ohm ±5% 1W METAL OXIDE FILM
R113	2440031022	150 ohm ±5% 1W METAL OXIDE FILM
R114	2440028022	82 ohm ±5% 1W METAL OXIDE FILM
R115	2440028022	82 ohm ±5% 1W METAL OXIDE FILM
R116	2412315022	22 ohm ±2% ¼W CARBON FILM FUSIBLE
R117	2412315022	22 ohm ±2% ¼W CARBON FILM FUSIBLE
R118	2412315019	10 ohm ±2% ¼W CARBON FILM FUSIBLE
R119	2452019029	120 ohm ±1% ¼W METAL OXIDE COMPOSIT
R120	2452019029	120 ohm ±1% ¼W METAL OXIDE COMPOSIT
R121	2452019029	120 ohm ±1% ¼W METAL OXIDE COMPOSIT
R122	2452019029	120 ohm ±1% ¼W METAL OXIDE COMPOSIT
R123	2442013064	33 kohm ±5% 1W METAL OXIDE FILM
R125	2790006011	112101-2 THERMISTOR
CAPACITORS		
C01	2556091008	470pF ±5% 50V PLASTIC FILM
C02	255	6.8µF ±20% 25V PLASTIC FILM
C03	2556161006	0.007µF ±5% 50V PLASTIC FILM
C04	2556161006	0.007µF ±5% 50V PLASTIC FILM
C05	2544009002	47µF 10V ELECTROLYTIC
C06	2544009002	47µF 10V ELECTROLYTIC

Ref. No.	Part No.	Part Name & Descriptions
C07	2521018003	22pF ±5% 50V MICA FILM
C08	2556083003	220pF ±5% 50V PLASTIC FILM
C09	2544009002	47µF 10V ELECTROLYTIC
C10	2544009002	47µF 10V ELECTROLYTIC
C11	2556087009	330pF ±5% 50V PLASTIC FILM
C14	2541024006	4.7µF ±20% 25V PLASTIC FILM
C15	2541024006	4.7µF ±20% 25V PLASTIC FILM
C16	2521018003	22pF ±5% 50V MICA FILM
C17	2521010001	10pF ±0.5pF 50V MICA FILM
C18	2556089007	390pF ±5% 50V PLASTIC FILM
C19	2544018006	100µF 16V ELECTROLYTIC
C20	2544018006	100µF 16V ELECTROLYTIC
C21	2551134025	0.01µF ±5% 50V PLASTIC FILM
C22	2521014007	15pF ±5% 50V MICA FILM
C23	2521014007	15pF ±5% 50V MICA FILM
C24	2544011003	220µF 10V ELECTROLYTIC
C25	2556105004	0.0018µF ±5% 50V PLASTIC FILM
C26	2556082004	200pF ±5% 50V PLASTIC FILM
C27	2544011003	220µF 10V ELECTROLYTIC
C28	2543013057	100µF 10V ELECTROLYTIC (BP)
C30	2544156007	100µF 160V ELECTROLYTIC (BP)
C31	2544003008	100µF 6.3V ELECTROLYTIC (BP)
C32	2556107002	0.0022µF ±5% 50V PLASTIC FILM
C33	2556107002	0.0022µF ±5% 50V PLASTIC FILM
C34	2556107002	0.0022µF ±5% 50V PLASTIC FILM
C35	2556107002	0.0022µF ±5% 50V PLASTIC FILM
C36	EP-7355	1µF 160V ELECTROLYTIC(HR)
C37	2561008060	10µF ±10% 100V METALIZED
C38	2544009002	47µF 10V ELECTROLYTIC
C39	2544009002	47µF 10V ELECTROLYTIC
C41	EP-7355	1µF 160V ELECTROLYTIC(HR)
C42	EP-7355	1µF 160V ELECTROLYTIC(HR)
C43	2544156007	100µF 160V ELECTROLYTIC
C44	2556091008	470pF ±5% 50V PLASTIC FILM
C47	EP-7355	1µF 160V ELECTROLYTIC(HR)
OTHER PARTS		
	2220743103	P.W. BOARD
	2090047903	JUMPER WIRE USED 33
	2090008104	JUMPER WIRE P=1mm USED 5
	EP-6071	BASE PIN
	2050122033	3P CONNECTOR PIN ASS'Y USED 5
	2050122046	4P CONNECTOR PIN ASS'Y USED 1
	2050122059	5P CONNECTOR PIN ASS'Y USED 1
	2050075025	2P TERMINAL USED 2
	4140240001	EARTH PLATE USED 2
	4170043100	RADIATOR
	4730354035	TAPPING SCREW (2) 3x8
	4170078201	RADIATOR
	4150180009	INST. SHEET (S-7)
	4150182007	BUSH (B-21)
	4700013005	CROSS PAN SCREW WITH 5.0V 3x14
	4756006008	NUT φ3
	4730454016	TAPPING SCREW 4x8 USED 2
	4140242009	SHIELD COVER

ETC-422 DRIVE UNIT PARTS LIST

Ref. No.	Part No.	Part Name & Descriptions		Ref. No.	Part No.	Part Name & Descriptions	
SEMICONDUCTORS							
IC01	2630118001	NJM4560D	INTEGRATED CIRCUIT	D05	2760049008	1S2076	DIODE
IC02	2630118001	NJM4560D	INTEGRATED CIRCUIT	D06	2760049008	1S2076	DIODE
IC03	2630118001	NJM4560D	INTEGRATED CIRCUIT	D08	2760049008	1S2076	DIODE
IC04	2630133002	μ PC741C	INTEGRATED CIRCUIT	D09	2760049008	1S2076	DIODE
IC05	2630118014	NJM4560DD	INTEGRATED CIRCUIT	D10	2760216019	KB-265	DIODE
IC06	2630127005	NE5534AN	INTEGRATED CIRCUIT	D11	2760216019	KB-265	DIODE
TR01	2750026044	2SK146(BL)	FIELD EFFECT TRANSISTOR	D12	2760049008	1S2076	DIODE
TR02	2750032009	2SJ73(BL)	FIELD EFFECT TRANSISTOR	D13	2760049008	1S2076	DIODE
TR03	2730256009	2SC2071(B)	TRANSISTOR	D14	2760254000	HZ7B-3	DIODE
TR04	2730256009	2SC2071(B)	TRANSISTOR	D15	2760049008	1S2076	DIODE
TR05	2730256009	2SC2071(B)	TRANSISTOR	D17	2760049008	1S2076	DIODE
TR06	2750033024	2SK147(GR1)	FIELD EFFECT TRANSISTOR	D18	2760254000	HZ7B-3	DIODE
TR07	2750034023	2SJ72(GR1)	FIELD EFFECT TRANSISTOR	D19	2760049008	1S2076	DIODE
TR08	2710148001	2SA939(B)	TRANSISTOR	D22	2760317002	HZ6LC-3	DIODE
TR09	2710148001	2SA939(B)	TRANSISTOR	D23	2760049008	1S2076	DIODE
TR10	2710148001	2SA939(B)	TRANSISTOR	D24	2760049008	1S2076	DIODE
TR11	2710148001	2SA939(B)	TRANSISTOR	D25	2760049008	1S2076	DIODE
TR12	2710148001	2SA939(B)	TRANSISTOR	D26	2760049008	1S2076	DIODE
TR13	2710148001	2SA939(B)	TRANSISTOR	D27	2760049008	1S2076	DIODE
TR14	2710148001	2SA939(B)	TRANSISTOR	D28	2760049008	1S2076	DIODE
TR15	2730256009	2SC2071(B)	TRANSISTOR	D29	2760184002	1S1834	DIODE
TR16	2730256009	2SC2071(B)	TRANSISTOR	D30	2760184002	1S1834	DIODE
TR17	2730256009	2SC2071(B)	TRANSISTOR	D31	2760254000	HZ7B-3	DIODE
TR18	2730256009	2SC2071(B)	TRANSISTOR	D32	2760254000	HZ7B-3	DIODE
TR19	2710094016	2SA970(BL)	TRANSISTOR	RESISTORS (not included $\pm 5\%$, $\frac{1}{4}W$ Carbon Film Type)			
TR20	2730188009	2SC1844(F)	TRANSISTOR	VR01	2116016038	SEMI FIXED RESISTOR 10 kohm	
TR21	2750033008	2SK147(GR1)/(GR2)	FIELD EFFECT TRANSISTOR	VR02	2116016041	SEMI FIXED RESISTOR 1 kohm	
TR22	2750034007	2SJ72(GR1)/(GR2)	FIELD EFFECT TRANSISTOR	VR03	2116016012	SEMI FIXED RESISTOR 500 ohm	
TR23	2710095002	2SA991(F)	TRANSISTOR	R07	2440112022	15 kohm $\pm 5\%$ 2W METAL OXIDE FILM	
TR24	2750026044	2SK146(BL)	FIELD EFFECT TRANSISTOR	R08	2442022000	1 kohm $\pm 5\%$ $\frac{1}{4}W$ METAL OXIDE FILM	
TR25	2730188009	2SC1844(F)	TRANSISTOR	R11	2440112022	15 kohm $\pm 5\%$ 2W METAL OXIDE FILM	
TR26	2730188009	2SC1844(F)	TRANSISTOR	R12	2442022000	1 kohm $\pm 5\%$ $\frac{1}{4}W$ METAL OXIDE FILM	
TR27	2730198015	2SC1815(BL)	TRANSISTOR	R15	2452014053	1 kohm $\pm 1\%$ $\frac{1}{2}W$ METAL OXIDE COMPOSIT	
TR28	2730198015	2SC1815(BL)	TRANSISTOR	R16	2452019016	47 ohm $\pm 1\%$ $\frac{1}{4}W$ METAL OXIDE COMPOSIT	
TR29	2730205005	2SC1941(L)	TRANSISTOR	R17	2452019029	120 ohm $\pm 1\%$ $\frac{1}{4}W$ METAL OXIDE COMPOSIT	
TR30	2750024020	μ PA68H(M)	FIELD EFFECT TRANSISTOR	R18	2452014053	1 kohm $\pm 1\%$ $\frac{1}{4}W$ METAL OXIDE COMPOSIT	
TR31	2750023018	2SK147(BL)	FIELD EFFECT TRANSISTOR	R20	2440057022	22 kohm $\pm 5\%$ 1W METAL OXIDE FILM	
TR32	2710102005	2SA1015(Y)	TRANSISTOR	R21	2440057022	22 kohm $\pm 5\%$ 1W METAL OXIDE FILM	
TR33	2710110000	2SA916(L)	TRANSISTOR	R24	2452019032	3 kohm $\pm 1\%$ $\frac{1}{4}W$ METAL OXIDE COMPOSIT	
TR34	2710102005	2SA1015(Y)	TRANSISTOR	R25	2452019032	3 kohm $\pm 5\%$ $\frac{1}{4}W$ METAL OXIDE COMPOSIT	
TR35	2730198002	2SC1815(Y)	TRANSISTOR	R26	2452019032	3 kohm $\pm 1\%$ $\frac{1}{4}W$ METAL OXIDE COMPOSIT	
TR36	2730198002	2SC1815(Y)	TRANSISTOR	R27	2452019032	3 kohm $\pm 1\%$ $\frac{1}{4}W$ METAL OXIDE COMPOSIT	
TR37	2710102005	2SA1015(Y)	TRANSISTOR	R28	2452014090	10 kohm $\pm 1\%$ $\frac{1}{2}W$ METAL OXIDE COMPOSIT	
TR38	2730256009	2SC2071(B)	TRANSISTOR	R29	2452014090	10 kohm $\pm 1\%$ $\frac{1}{2}W$ METAL OXIDE COMPOSIT	
TR39	2730198002	2SC1815(Y)	TRANSISTOR	R30	2452019032	3 kohm $\pm 1\%$ $\frac{1}{4}W$ METAL OXIDE COMPOSIT	
TR40	2710102005	2SA1015(Y)	TRANSISTOR	R31	2452019032	3 kohm $\pm 1\%$ $\frac{1}{4}W$ METAL OXIDE COMPOSIT	
TR41	2710148001	2SA939(B)	TRANSISTOR	R32	2452019032	3 kohm $\pm 1\%$ $\frac{1}{4}W$ METAL OXIDE COMPOSIT	
TR42	2730259006	2SC2238B(Y)	TRANSISTOR	R33	2452019032	3 kohm $\pm 1\%$ $\frac{1}{4}W$ METAL OXIDE COMPOSIT	
TR43	2730259006	2SC2238B(Y)	TRANSISTOR	R34	2452019058	20 kohm $\pm 1\%$ $\frac{1}{4}W$ METAL OXIDE COMPOSIT	
TR44	2710151001	2SA968B(Y)	TRANSISTOR	R40	2452012097	2.7 kohm $\pm 1\%$ $\frac{1}{4}W$ METAL OXIDE COMPOSIT	
TR45	2710151001	2SA968B(Y)	TRANSISTOR				
TR47	2730256009	2SC2071(B)	TRANSISTOR				
TR48	2710148001	2SA939(BL)	TRANSISTOR				
TR50	2730187013	2SC2240(BL)	TRANSISTOR				
TR51	2750020037	2SK163(L)	FIELD EFFECT TRANSISTOR				
D01	2760254000	HZ7B-3	DIODE				
D02	2760254000	HZ7B-3	DIODE				
D03	2760254000	HZ7B-3	DIODE				
D04	2760254000	HZ7B-3	DIODE				

PRINTED WIRING BOARD PATTERNS AND PARTS LIST
ETC-422 DRIVE UNIT

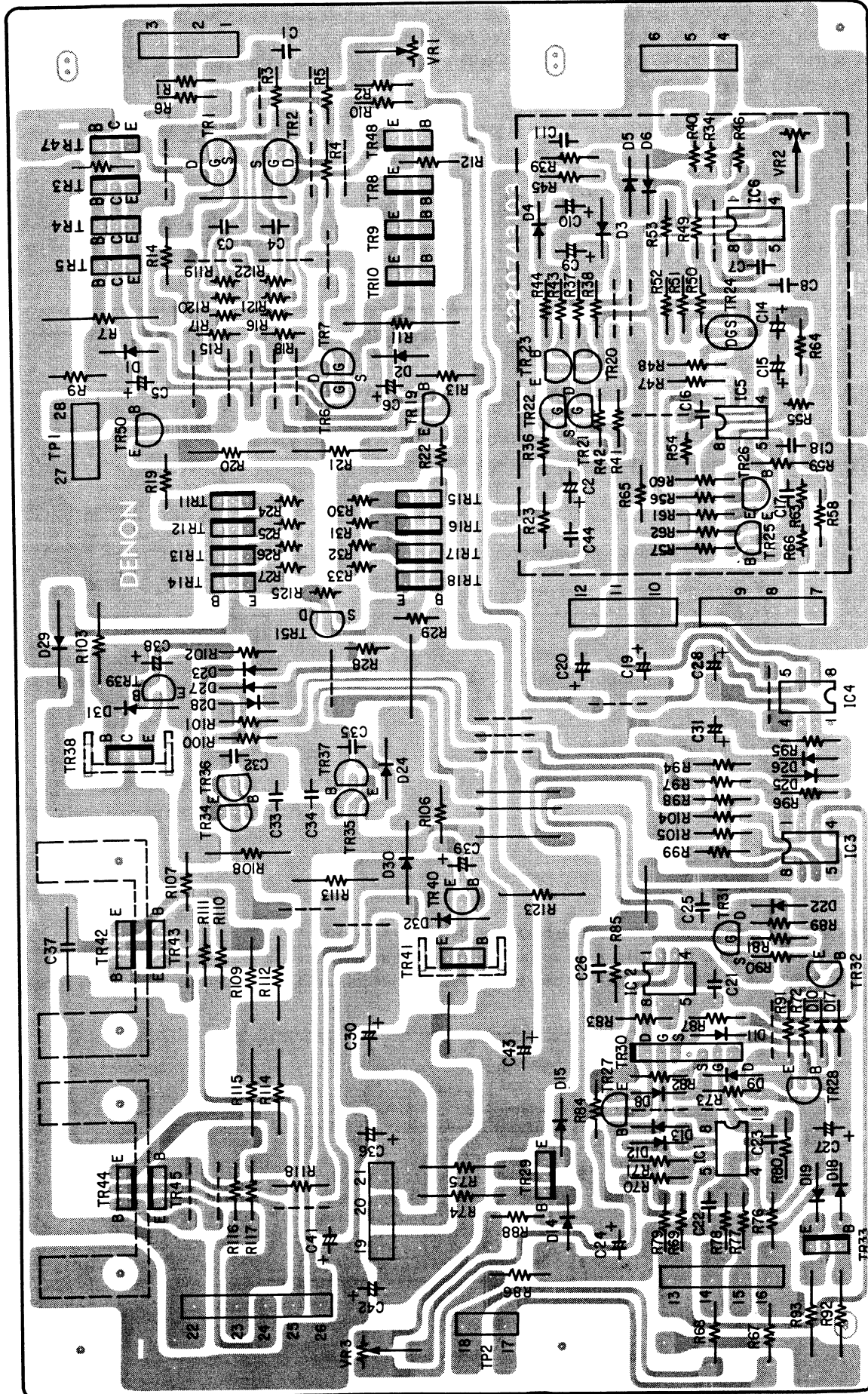

5. Distortion Adjustment

- a) Turn level volume slowly to MAX. Adjust input signal level to obtain 40V/1 kHz output.
- b) Common mode level Adjustment

Adjust VR-2 of ETC-0422 so as the common mode level at 40V/1 kHz output becomes minimum: waveform on the synchroscope which is connected to current probe shall be minimum.

If a current probe is unavailable, connect an Oscilloscope across the distortion absorbing resistor R_X , and adjust VR-2 to make the waveform level minimum.

How to hook up when current probe is unavailable.

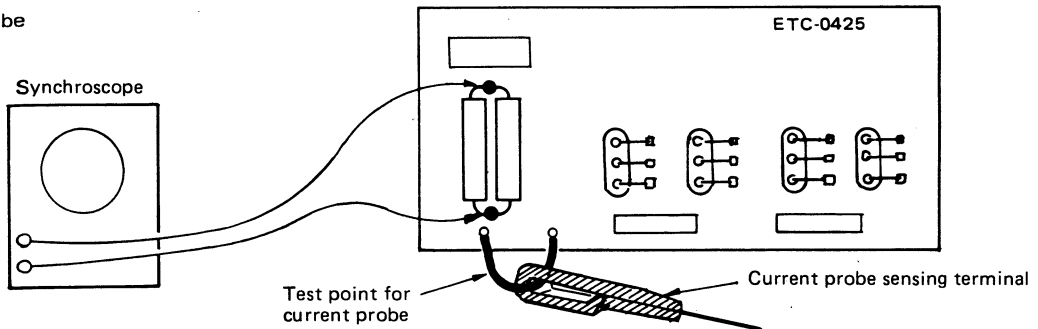

Precaution: Keep one channel open when using a double phenomena synchroscope.

- c) After adjusting common mode level, check distortion at 1 kHz is less than 0.003%.
- d) Set generator frequency to 20 Hz. Keep output level 40V/8 ohm, 200W.

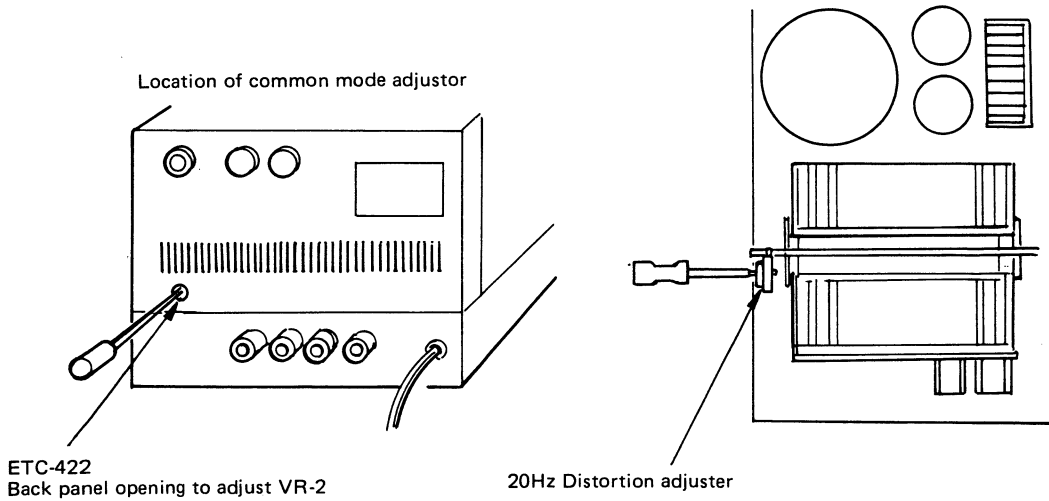

- e) Adjust VR-1 of radiator unit ETC-0423 to minimize distortion at 20 Hz.
- f) Set generator frequency to 20 kHz. Keep output level 40V/8 ohm, 200W.
- g) Adjust coils of distortion eliminator circuit to minimize distortion at 20 kHz. (Change coil pitches to adjust the coils)

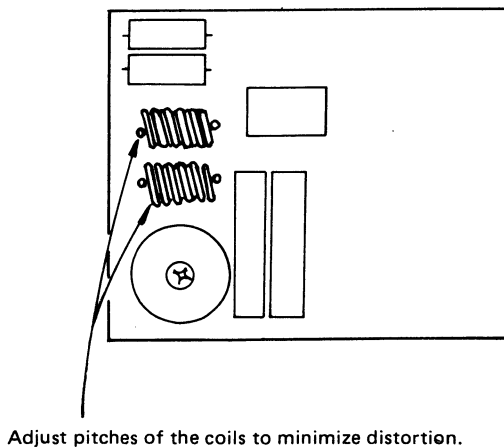

WIRING DIAGRAM

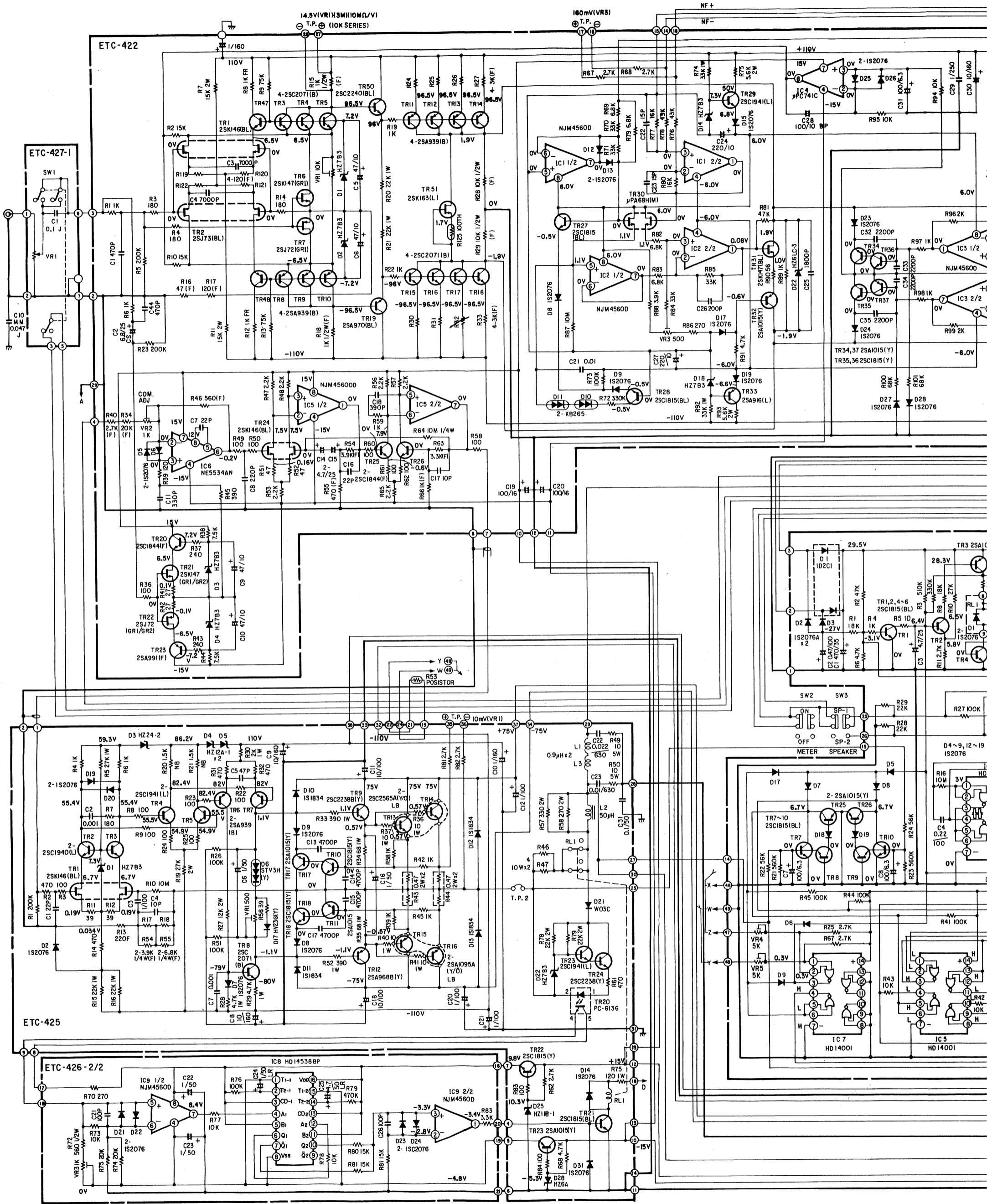

⚠ Means important safety item, which must be replaced, when necessary, by a part specified or meeting the specification by the manufacturer.

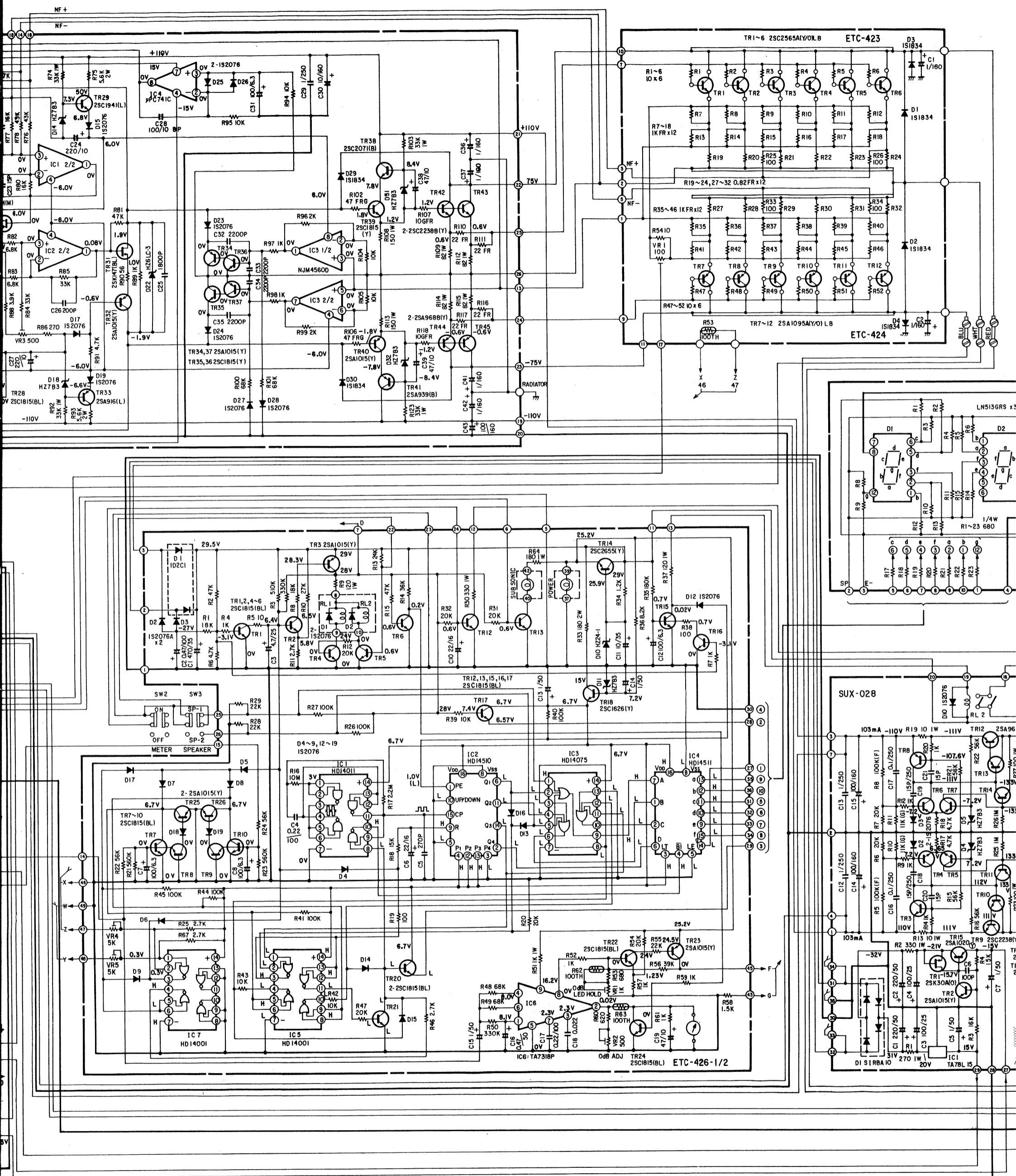

Symbol	Description
F 5	POWER TRANS
C 9	

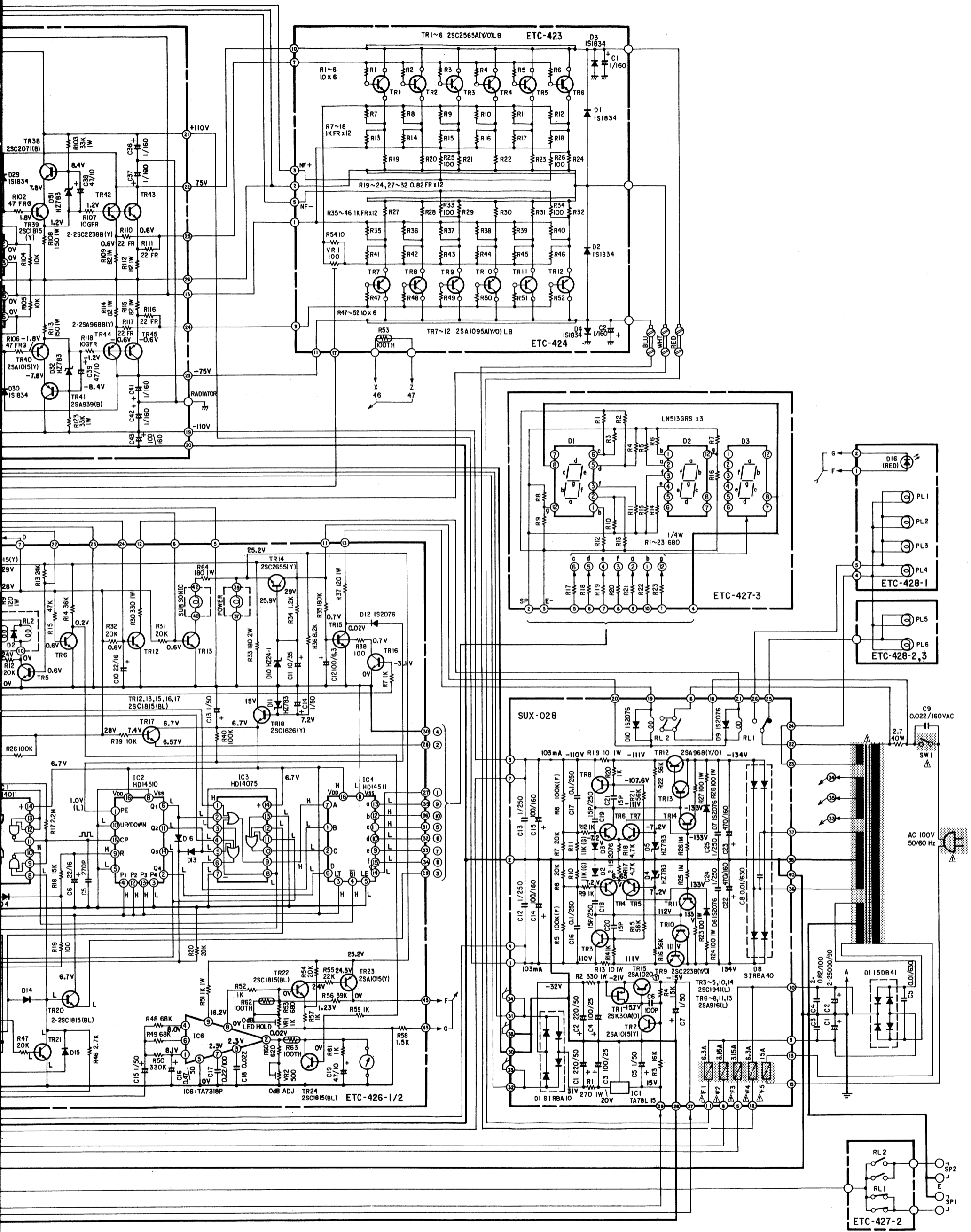

Symbol	E2	E3	E1H	E1S	EK
F 5	8ATL	15A	8ATL	8ATL	8ATL
C 9	0.01/600V	0.022/125VUL	0.01/600V	0.01/600V	0.01/600V
POWER TRANS	AC220V/50Hz CLASS - II	AC120V/60Hz UL.CSA	AC200V/50Hz	AC230V/50Hz	AC240V/50Hz

BS

⚠ Means important safety when necessary, by a part spe by the manufacturer.

EXPLODED VIEW OF CHASSIS AND CABINET

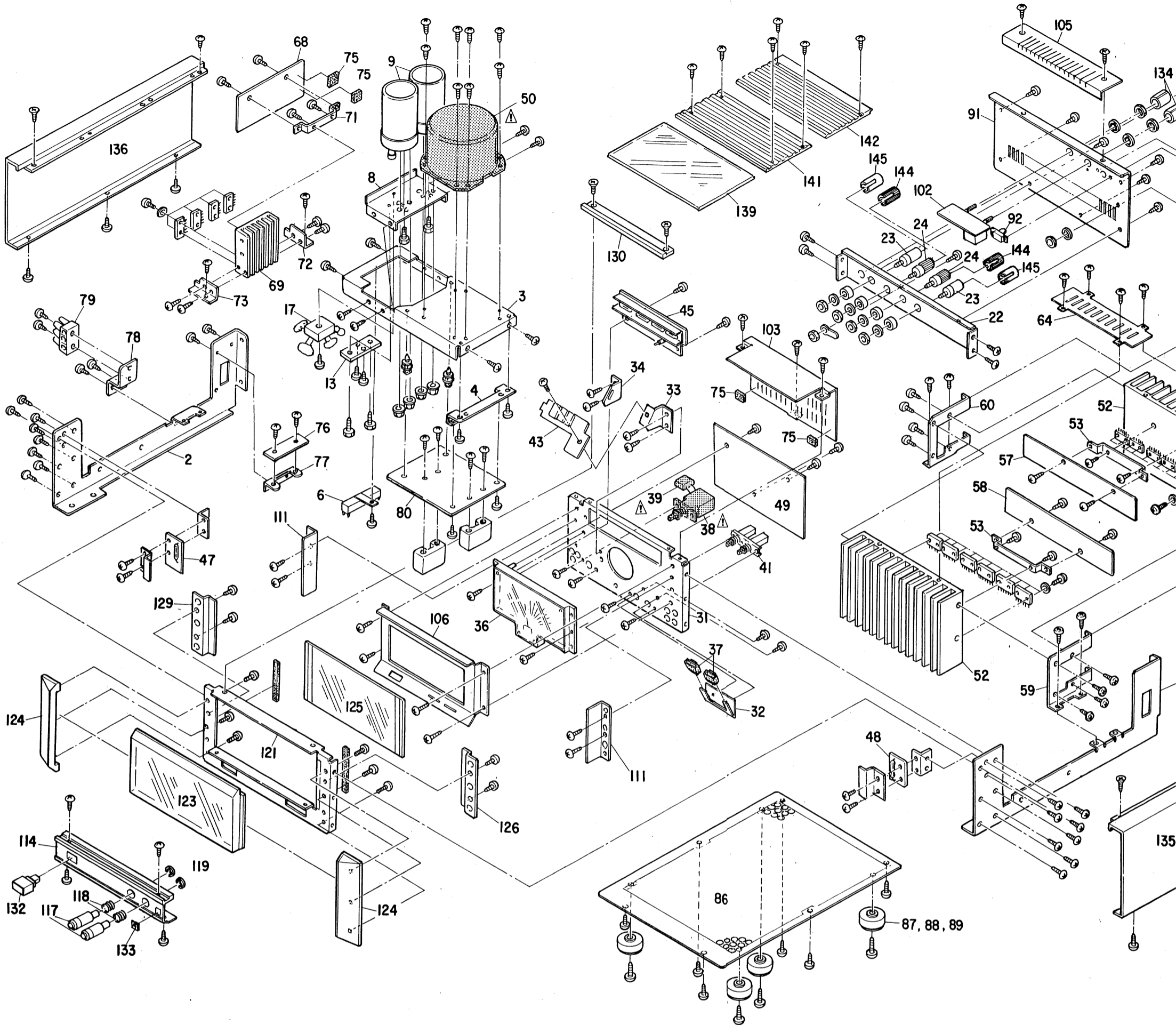

EXPLODE VIEW OF PARTS LIST

Note: See addendum list below for the Parts with asterisk (*) on the Ref. No. and the other Part not included in this List.

Ref. No.	Part No.	Part Name & Descriptions
1	4110312105	SIDE CHASSIS (R)
2	4110313104	SIDE CHASSIS (L)
3	4110314006	TRANS CHASSIS
4	4120927001	BOARD BRACKET (B)
5	4730354035	TAPPING SCREW (2) 3x8
6	2432038004	WIRE WOUND RESISTOR 2.7 OHM
7	MD-5271	P.C.B. SUPPORT
8	4120928000	CHEMICON BRACKET
9	2546056008	CHEMICON 25000μF
10	SC-1050H	NUT
11	2030205022	CONTACT ASS'Y
12	2030205035	CONTACT ASS'Y
13	2050140002	EARTH PLATE
14	2050010006	5T LUG
15	2050003000	3T LUG
16	4700025019	TAPPING SCREW (2) 3x6 TWB
17	2760257007	DIODE 15D4B41
18	4730359014	TAPPING SCREW (2) 3x16
19	2561017019	METALIZED CAP. 0.01μF (630V)
20	2561018005	METALIZED CAP. 1μF (250V)
21	4770064107	FIXING SCREW
22	4120932009	BACK FRAME
23	2050115008	1P TERMINAL (BLACK)
24	2050115011	1P TERMINAL (RED)
25	4752005003	φ5 SPRING WASHER
26	EP-5868	4T LUG
27	4700042005	CROSS PAN SCREW WITH S.WASHER 3x8 (BLACK)
28	SC-10822	NUT-WASHER
29	2030222050	1P CONNECTOR CORD
30	2030225002	1P CONNECTOR CORD
31	4110315102	FRONT CHASSIS
32	4120929009	LAMP HOLDER
33	4120930001	BRACKET (FR)

Ref. No.	Part No.	Part Name & Descriptions
34	4120931000	BRACKET (FL)
35	4730353036	TAPPING SCREW (2) 3x6 (MFN1B)
36	2150050102	METER ASS'Y
37	3930067000	PILOT LAMP (28V 0.4A) ASS'Y
38	2124049068	POWER SWITCH
39	2124049068	METALIZED CAP. 0.022μF/125V AC
40	4711303018	CROSS PAN SCREW 3x6
41	2124318003	2P PUSH SWITCH
42	2038097009	5P CONNECTOR CORD
43	ETC0427-3	LED UNIT
44	1430110093	FILTER
45	ETC0428-1	METER LAMP ASS'Y
46	4730304014	TAPPING SCREW (1) 3x8
47	ETC0428-2	LAMP (L) UNIT
48	ETC0428-3	LAMP (R) UNIT
49	ETC0426	METER & PROTECTOR UNIT
50	4774454038	POWER TRANS
51	4774454038	TAPPING SCREW (TRUS) 4x8 (BLACK)
52	4170150103	POWER RADIATOR
53	4410350100	P.C.B. BRACKET
54	2710147002	TRANSISTOR 2SA1095A(Y)/(O) LB
55	2730255000	TRANSISTOR 2SC2565A(Y)/(O) LB
56	4700012022	CROSS PAN SCREW WITH S.WASHER 3x12
57	ETC0423	POWER OUT (A) UNIT
58	ETC0424	POWER OUT (B) UNIT
59	4120933008	RADIATOR BRACKET (R)
60	4120934007	RADIATOR BRACKET (L)
61	EP-6214	CORD HOLDER
62	ETC0422	DRIVE UNIT
63	2544155008	CHEMICON 1μF (160V)
64	4140243008	PUNCHING PLATE (A)
65	2034168000	3P CONNECTOR CORD
66	2034169009	3P CONNECTOR CORD

Ref. No.	Part No.	Part Name & Descriptions
67	2034171000	3P CONNECTOR CORD
68	ETC0425	CANSELER UNIT
69	4170151209	RADIATOR
70	2034172009	3P CONNECTOR ASS'Y
71	4410351109	P.C.B. BRACKET
72	4120937004	BRACKET (1)
73	4120938003	BRACKET (2)
74	SC-06272	FIX. SCREW
75	4610136014	RUBBER SHEET
76	ETC04272	RELAY UNIT
77	4120936005	BOARD BRACKET
78	4120935006	3P CONNECTOR BRACKET
79	2050086014	3P TERMINAL BLOCK
80	SUX0028	POWER SUPPLY UNIT
81	2062021009	CORD BUSH
82	2062021009	AC CORD
83	2030227000	1P CONNECTOR CORD
84	2030225015	1P CONTACT ASS'Y
85	2034146001	3P CONNECTOR CORD
86	1050412003	BOTTOM COVER
87	1440893009	FOOT BASE
88	1240038019	FELT SHEET
89	4610170009	SPACER
90	4730459011	TAPPING SCREW (2) 4x16
91	1050	BACK PANEL
92	2030169113	1P CONNECTOR BASE
93	4714304030	TAPPING SCREW 3x8 (BLACK)
94	4753001051	TOOTH WASHER φ3
95	2554081007	PLASTIC FILM CAPACITOR 0.047μF (100V)
96	4752003005	φ3 SPRING WASHER
97	2050043109	GND TERMINAL
98	4753100004	TOOTH WASHER φ4
99	4770088002	WASHER φ4.1

⚠ Means important safety item, which must be replaced, when necessary, by a part specified or meeting the specification by the manufacturer.

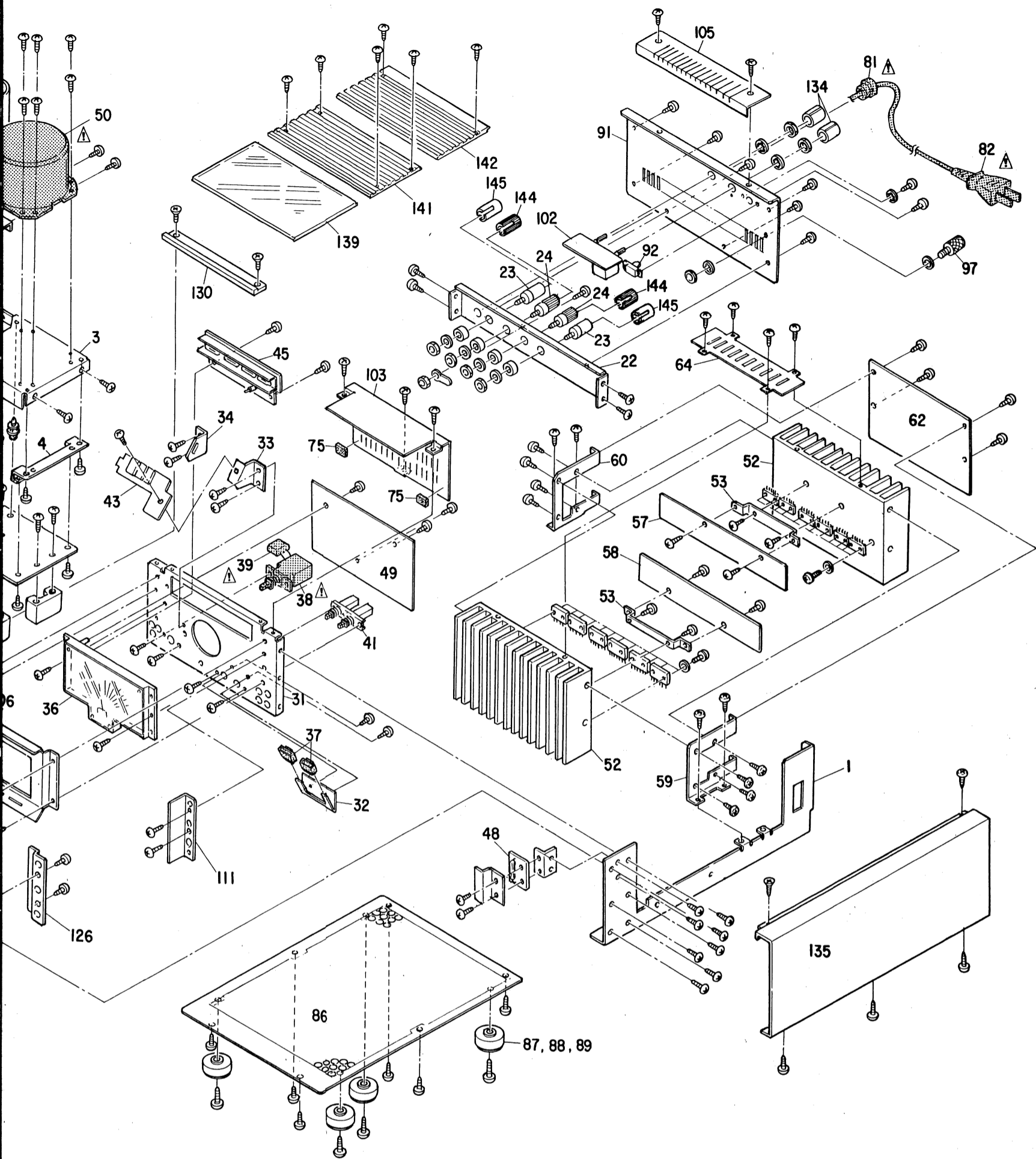

Refer to the Parts with asterisk (*) on the Ref. No. and the other Part not included in this List.

Part No.	Part Name & Descriptions
4120931000	BRACKET (FL)
4730353036	TAPPING SCREW (2) 3x6 (MFN1B)
2150050102	METER ASS'Y
3930067000	PILOT LAMP (28V 0.4A) ASS'Y
2124049068	POWER SWITCH
4711303018	CROSS PAN SCREW 3x6
2124318003	2P PUSH SWITCH
2038097009	5P CONNECTOR CORD
ETC0427-3	LED UNIT
1430110093	FILTER
ETC0428-1	METER LAMP ASS'Y
4730304014	TAPPING SCREW (1) 3x8
ETC0428-2	LAMP (L) UNIT
ETC0428-3	LAMP (R) UNIT
ETC0426	METER & PROTECTOR UNIT
4774454038	TAPPING SCREW (TRUS) 4x8 (BLACK)
4170150103	POWER RADIATOR
4410350100	P.C.B. BRACKET
2710147002	TRANSISTOR 2SA1095A(Y)/(O) LB
2730255000	TRANSISTOR 2SC2565A(Y)/(O) LB
4700012022	CROSS PAN SCREW WITH S.WASHER 3x12
ETC0423	POWER OUT (A) UNIT
ETC0424	POWER OUT (B) UNIT
4120933008	RADIATOR BRACKET (R)
4120934007	RADIATOR BRACKET (L)
EP-6214	CORD HOLDER
ETC0422	DRIVE UNIT
2544155008	CHEMICON 1μF (160V)
4140243008	PUNCHING PLATE (A)
2034168000	3P CONNECTOR CORD
2034169009	3P CONNECTOR CORD

Ref. No.	Part No.	Part Name & Descriptions
67	2034171000	3P CONNECTOR CORD
68	ETC0425	CANSELER UNIT
69	4170151209	RADIATOR
70	2034172009	3P CONNECTOR ASS'Y
71	4410351109	P.C.B. BRACKET
72	4120937004	BRACKET (1)
73	4120938003	BRACKET (2)
74	SC-06272	FIX. SCREW
75	4610136014	RUBBER SHEET
76	ETC04272	RELAY UNIT
77	4120936005	BOARD BRACKET
78	4120935006	3P CONNECTOR BRACKET
79	2050086014	3P TERMINAL BLOCK
80	SUX0028	POWER SUPPLY UNIT
81	81	CORD BUSH
82	2062021009	AC CORD
83	2030227000	1P CONNECTOR CORD
84	2030225015	1P CONTACT ASS'Y
85	2034146001	3P CONNECTOR CORD
86	1050412003	BOTTOM COVER
87	1440893009	FOOT BASE
88	1240038019	FELT SHEET
89	4610170009	SPACER
90	4730459011	TAPPING SCREW (2) 4x16
91	1050	BACK PANEL
92	2030169113	1P CONNECTOR BASE
93	4714304030	TAPPING SCREW 3x8 (BLACK)
94	4753001051	TOOTH WASHER φ3
95	2554081007	PLASTIC FILM CAPACITOR 0.047μF (100V)
96	4752003005	φ3 SPRING WASHER
97	2050043109	GND TERMINAL
98	4753100004	TOOTH WASHER φ4
99	4770088002	WASHER φ4.1

Ref. No.	Part No.	Part Name & Descriptions
100	4770006000	NUT φ4
101	4751003006	WASHER φ3
102	ETC04271	INPUT UNIT
103	4140244104	BLIND COVER
104	4610074192	BLIND
105	4140245006	PUNCHING PLATE (B)
106	1440894008	INSIDE PANEL
107	1430148036	FILTER
108	1430148049	FILTER
109	1430148052	FILTER
110	1220069053	SPACER
111	4140246005	BLIND PLATE
112	4610169049	RUBBER SHEET
113	2707PA014	FRONT PANEL SUB ASS'Y
114	1440883006	UNDER PANEL
115	1140058005	KNOB GUIDE (A)
116	1140059004	KNOB GUIDE (B)
117	1130280100	PUSH KNOB
118	4630226014	SPRING
119	4761007005	E RING φ7
120	1220069082	SPACER
121	4120940004	PANEL BRACKET
122	1220069040	SPACER
123	1430213107	WINDOW GLASS
124	1440884005	SIDE ESC. BAR
125	1430214203	INDOOR WINDOW
126	4120941003	WINDOW BRACKET (R)
127	4610169036	RUBBER SHEET
128	1430110080	FILTER
129	4120942002	WINDOW BRACKET (L)
130	1460424005	TOP ESC. BAR
131	4712303033	FLAT HEAD SCREW 3x6 (BLACK)
132	1130281002	PUSH KNOB ASS'Y
133	1350035025	MARK

Ref. No.	Part No.
134	11202700
135	14408850
136	14408860
137	47323550
138	47700520
139	14302150
140	12200690
141	14408870
142	14408970
143	47113040
144	46200360
145	46200360

ADDENDUM L

Ref. No.	Part No.
Δ 38	
Δ 39	
Δ 50	
Δ 81	
Δ 82	
91	

NIPPON CO
No. 14-14, 4-CH
MINATO-KU, T
TEL: 03-584-8
TLX: JAPANO
CABLE: NIPPO

ity item, which must be replaced,
pecified or meeting the specification

DENON

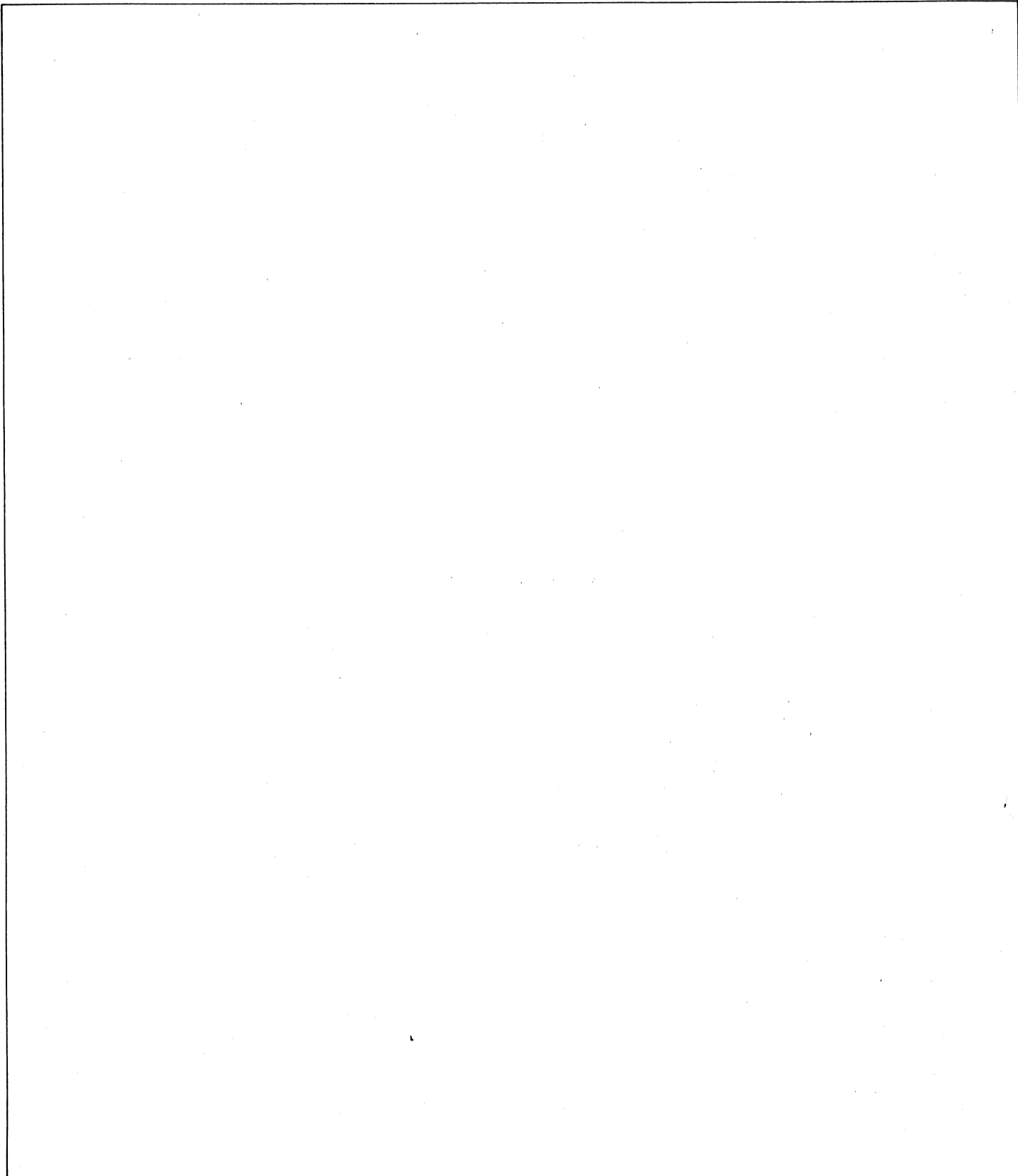
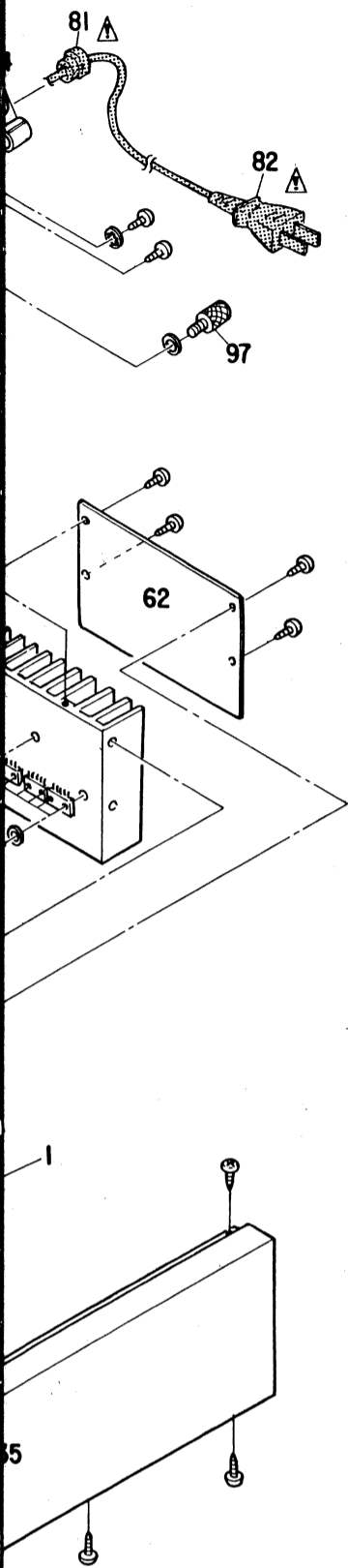

NIPPON COLUMBIA CO., LTD.

No. 14-14, 4-CHOME AKASAKA,
MINATO-KU, TOKYO 107 JAPAN
TEL: 03-584-8111
TLX: JAPANOLA J22591
CABLE: NIPPONCOLUMBIA TOKYO

Printed in Japan

Ref. No.	Part No.	Part Name & Descriptions
100	4770006000	NUT ϕ 4
101	4751003006	WASHER ϕ 3
102	ETC04271	INPUT UNIT
103	4140244104	BLIND COVER
104	4610074192	BLIND
105	4140245006	PUNCHING PLATE (B)
106	1440894008	INSIDE PANEL
107	1430148036	FILTER
108	1430148049	FILTER
109	1430148052	FILTER
110	1220069053	SPACER
111	4140246005	BLIND PLATE
112	4610169049	RUBBER SHEET
113	2707PA014	FRONT PANEL SUB ASS'Y
114	1440883006	UNDER PANEL
115	1140058005	KNOB GUIDE (A)
116	1140059004	KNOB GUIDE (B)
117	1130280100	PUSH KNOB
118	4630226014	SPRING
119	4761007005	E RING ϕ 7
120	1220069082	SPACER
121	4120940004	PANEL BRACKET
122	1220069040	SPACER
123	1430213107	WINDOW GLASS
124	1440884005	SIDE ESC. BAR
125	1430214203	INDOOR WINDOW
126	4120941003	WINDOW BRACKET (R)
127	4610169036	RUBBER SHEET
128	1430110080	FILTER
129	4120942002	WINDOW BRACKET (L)
130	1460424005	TOP ESC. BAR
131	4712303033	FLAT HEAD SCREW 3x6 (BLACK)
132	1130281002	PUSH KNOB ASS'Y
133	1350035025	MARK

Ref. No.	Part No.	Part Name & Descriptions
134	1120270007	KNOB
135	1440885004	SIDE COVER (R)
136	1440886003	SIDE COVER (L)
137	4732355032	FLAT HEAD TAPPING SCREW (2) 3x10 (BLACK)
138	4770052012	FIX. SCREW
139	1430215008	TOP WINDOW GLASS
140	1220069079	SPACER
141	1440887002	VENTILATOR
142	1440897005	VENTILATOR
143	4711304033	CROSS PAN SCREW 3x8 (MFN1B)
144	4620036007	TERMINAL CAP (BLACK)
145	4620036010	TERMINAL CAP (RED)

Ref. No.	Part No.	Name & Descriptions
PACKING & ACCESSORIES (not included EXPLODED VIEW)		
a	5040055007	CABINET SHEET
b	5020509104	CUSHION (1)
c	5020510009	CUSHION (2)
* d	501	CARTON CASE
* e	5110983009	INST. MANUAL

ADDENDUM LIST

Ref. No.	Part Name & Descriptions	Part No.			
		E2 for Europe	EK for U.K.	E1 for Singapore	E1 for Hong Kong
Δ 38	POWER SWITCH	2124049068			
Δ 39	CAPACITOR				
Δ 50	POWER TRANS				
Δ 81	CORD BUSH	4460020005			
Δ 82	AC CORD	4062016001	2062020000	2062016001	2066029009
91	BACK PANEL				