

D&M

D&M Holdings Inc.

100 Corporate Drive Mahwah, NJ 07430

DENON

Service Bulletin

No. : OST-C1528

Date: July 1, 2009

Model: POA-A1HDCI

Subject: Change the voltage of power supply for OP amplifier.
Countermeasure is applicable only upon claim from the customer.

Symptom: The unit goes into protection mode.

Solution: Generally OP amplifier is not defective at "+18/-18 volts" power supply, but few OP amplifiers was damaged by over "+15/-15 volts".

COUNTERMEASURE: We pulled down the voltage of the power supply from "+18/-18 volts" to "+15/-15 volts".

1) 1U-3798-1 AMP UNIT:

a) IC102, IC103: SA5532ADR (00D2623555901)→NJM5532M-D (TE-1)(00D2630898907)

b) ZD101, ZD102: HZS22-1 (00D2760480900)→HZS20-1TD (00D2760479908)

2) 1U-3798-2 INPUT UNIT: a) JV39, JV42, JV58: Jumper Wire→HZS3B-2TD (00D2760453911)

See the following picture for details.

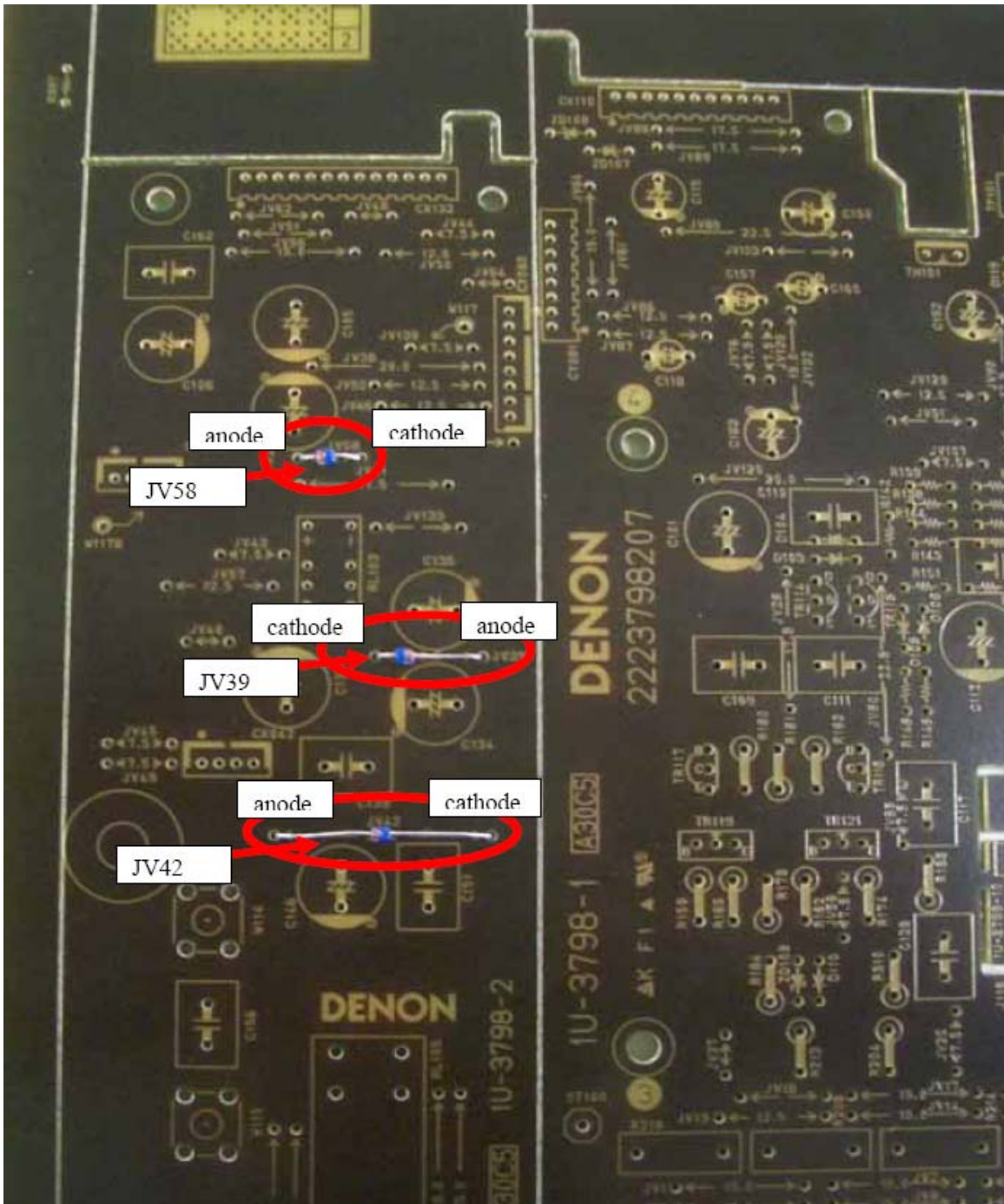

- b) Cut the pattern of minus line in IC104.
c) Solder the diode HZS3B-2 to the PCB with a RUBBER SHEET under the component (on PC board).

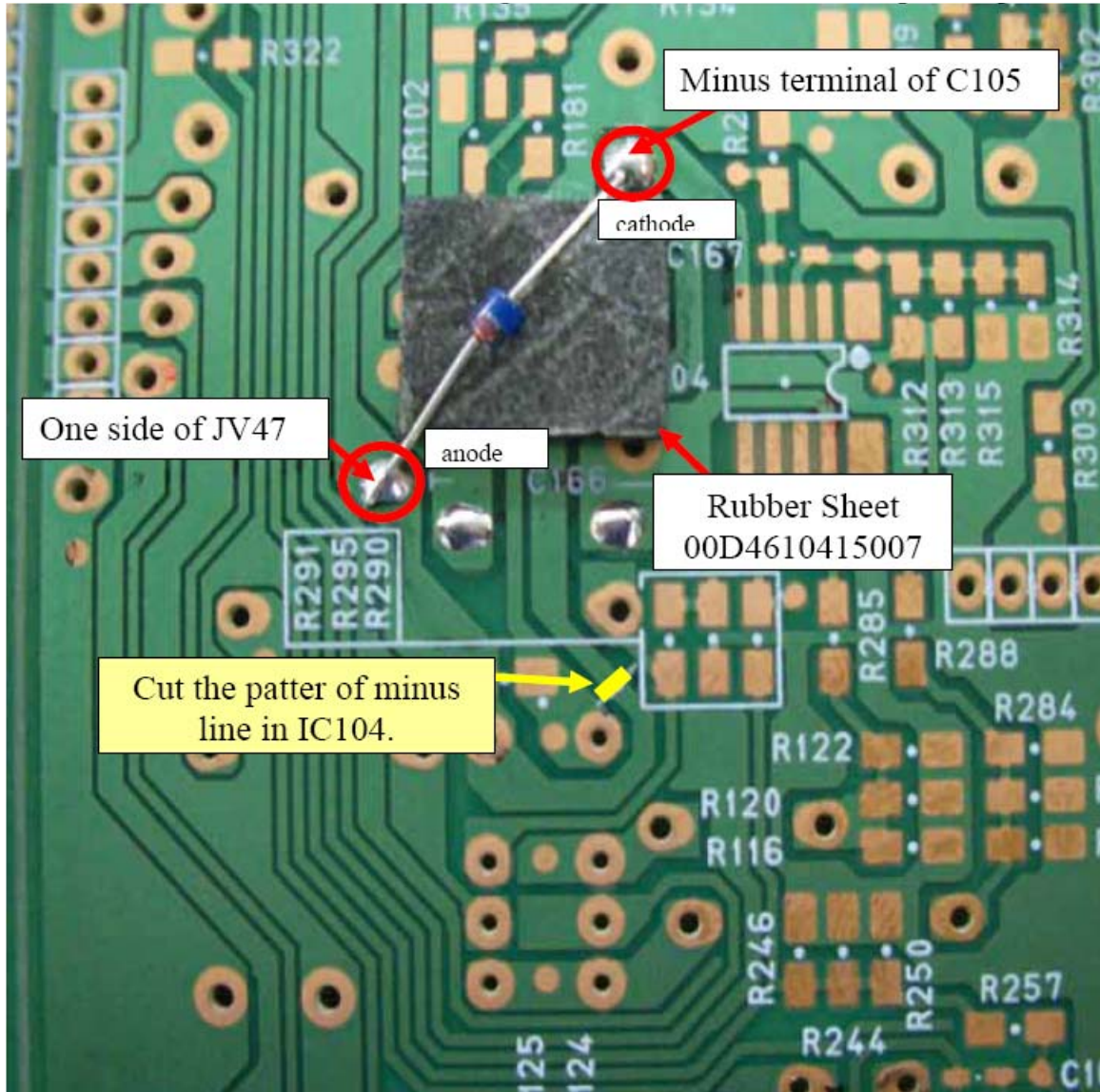

d) IC101, IC104: SA5532ADR (00D2623555901)→SE5532AD8R2G (232810020503S)

3) 1U-3797-3/4/5/6/7 CONNECT UNIT:

a) IC511, IC512, IC513, IC514, IC515: SA5532ADR (00D2623555901)→SE5532AD8R2G (232810020503S)

b) Cut the pattern of the power supply line for OP amplifier.

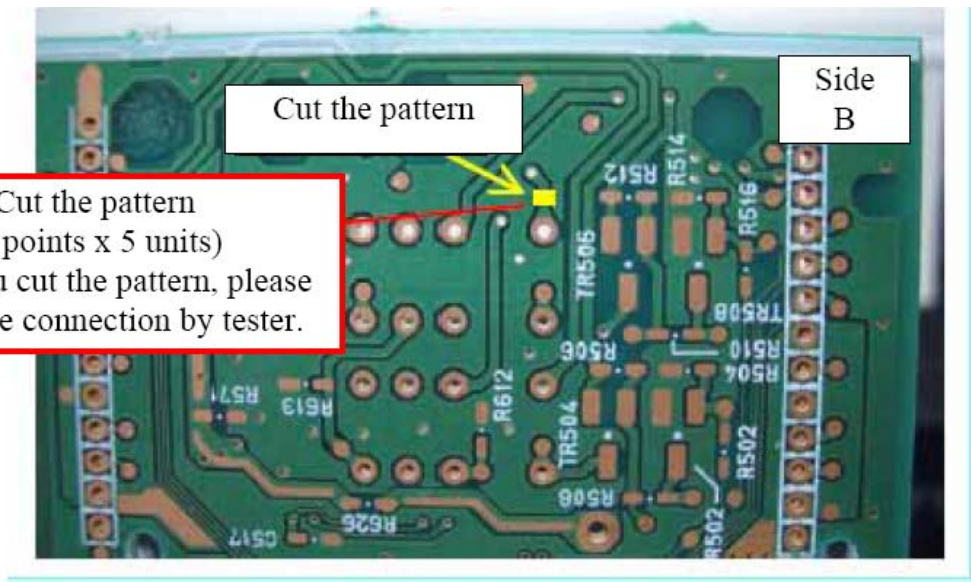
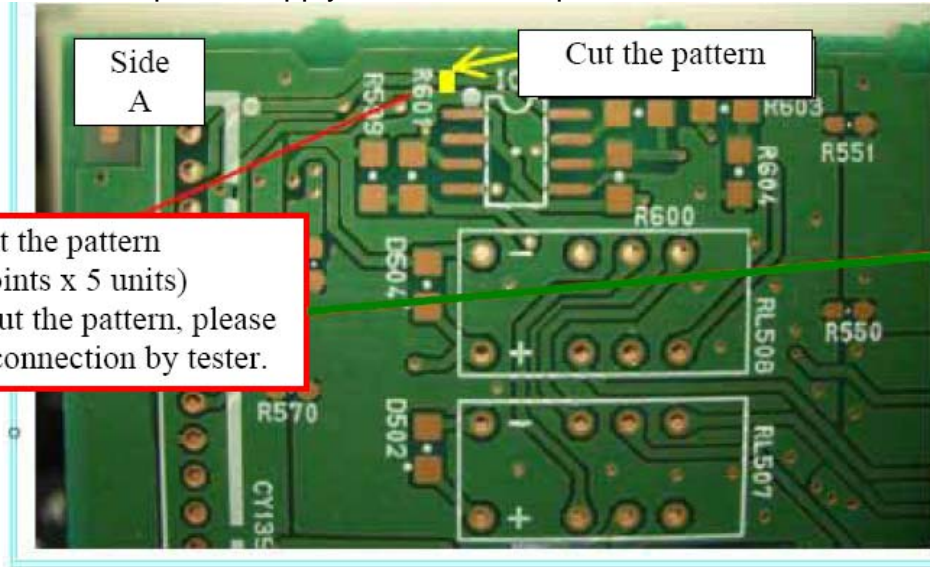

Side
A

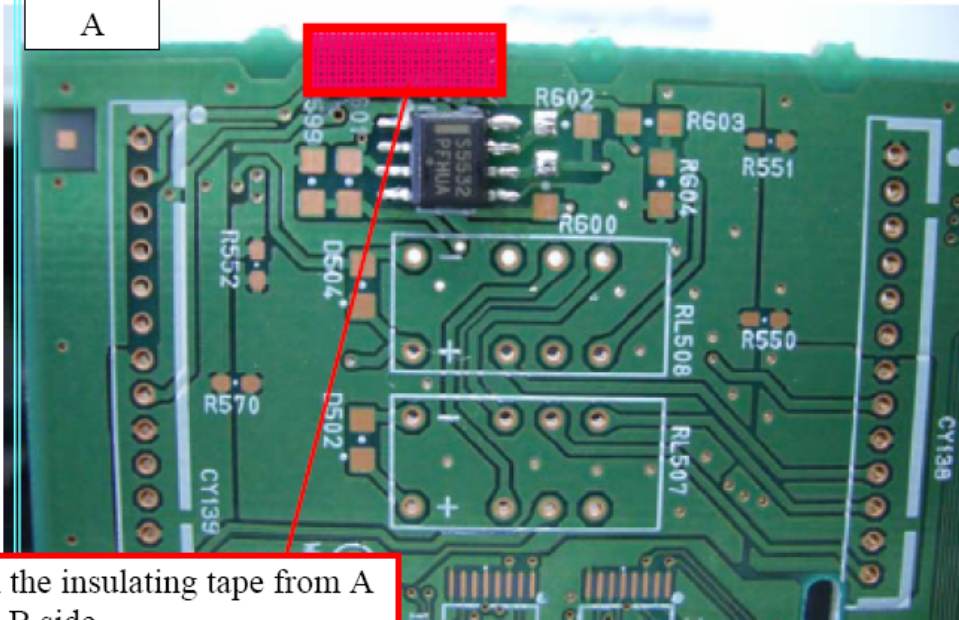

Attach the insulating tape from A side to B side.
(W=10mm x L=15mm)

Side
A

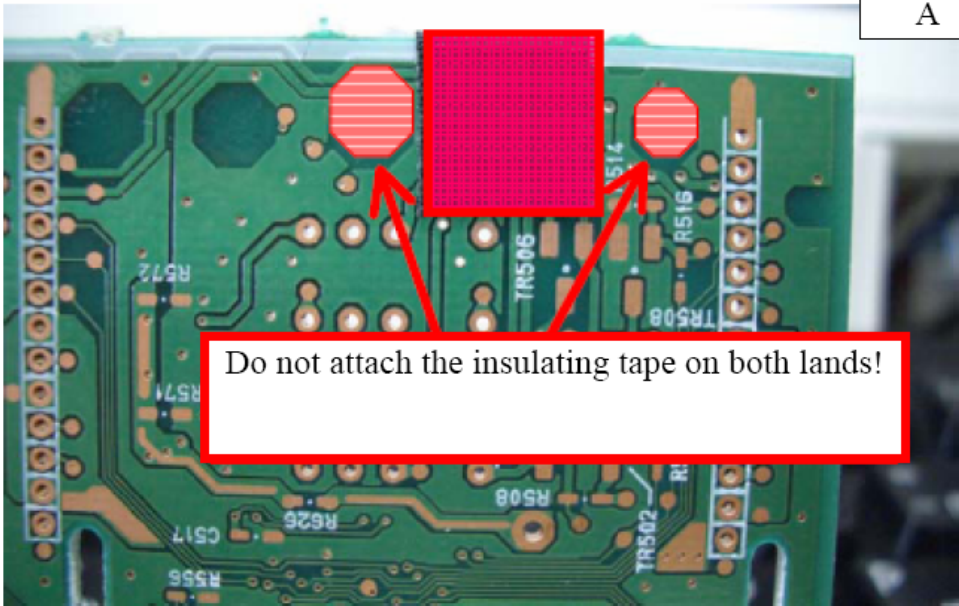

Do not attach the insulating tape on both lands!



Attach the insulating tape
from A side to B side.

c) Attach the RUBBER SHEET and cloth tape on the printing board.

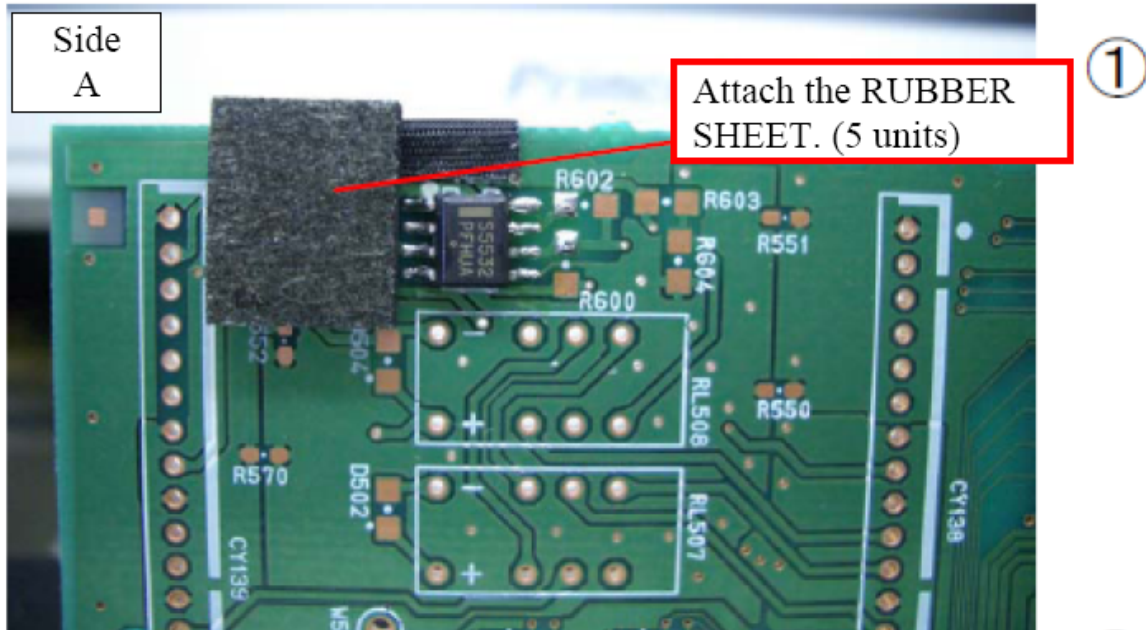

d) Attach the HZS3B-2 (00D2760453911) on the A side of printing board.

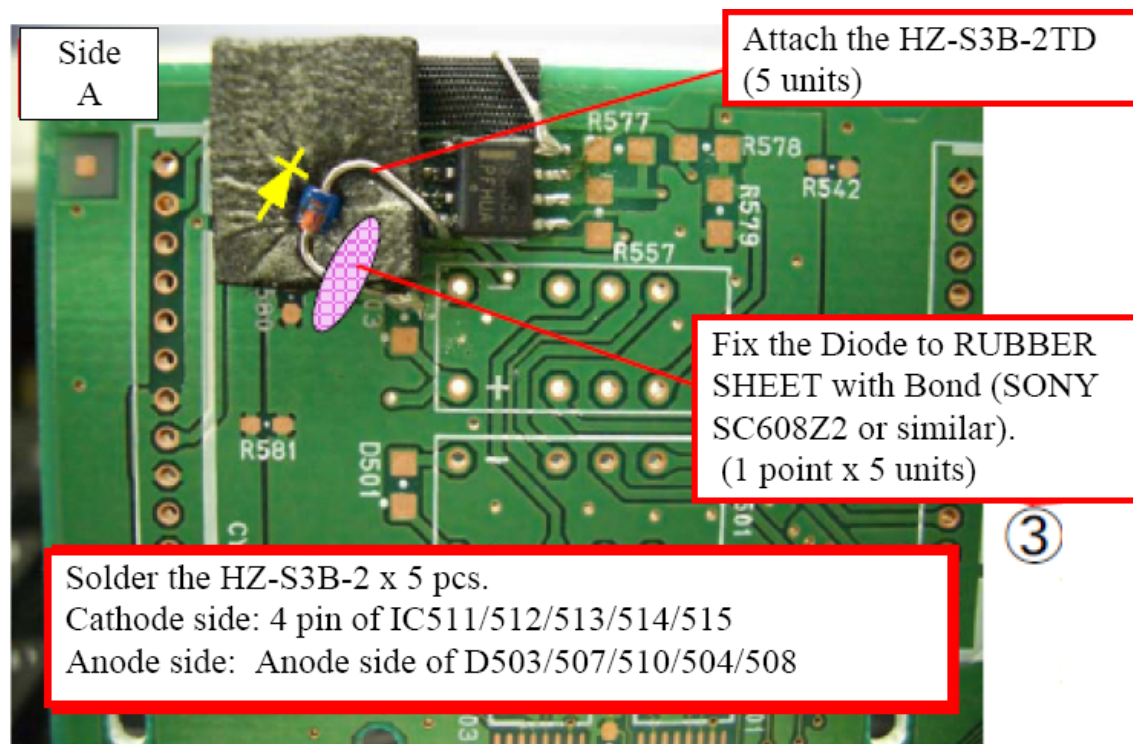

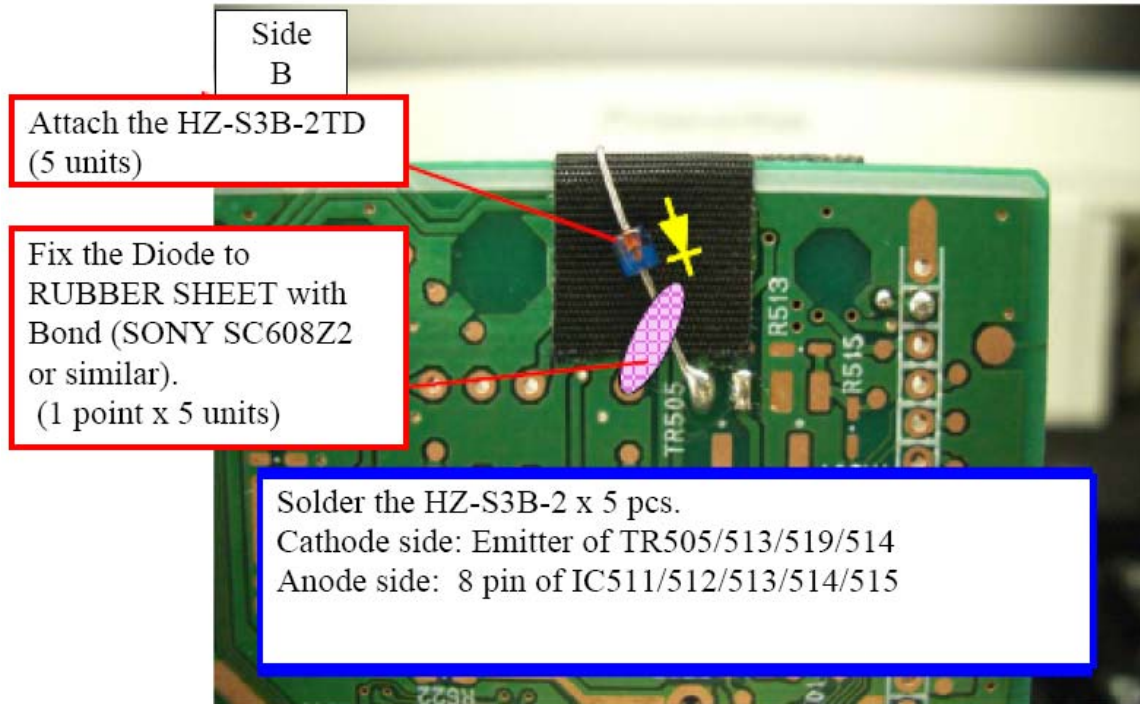

Caution!:

- 1) Do not mistake the direction (position) of the diodes. Please verify proper positioning BEFORE soldering.
- 2) Do not use the wrong diodes. (There are 2 types of Diodes used.)
- 3) Do not cut the wrong patterns. Please check it by (DVM) tester.

Parts:

Ref#	Description	Part Number
JV39, JV42, JV58	HZS3B-2TD	00D2760453911
IC101, IC104, IC511, IC512, IC513, IC514, IC515	SE5532AD8R2G	232810020503S
IC102, IC103	NJM5532M-D(TE1)	00D2630898907
ZD101, ZD102	HZS20-1TD	00D2760479908
For HZS3B-2TD	RUBBER SHEET	00D4610415007

Serial Number Range:

Please apply the above modification to the production models in the following serial numbers. (Last 5-digits)
00001 ~ 00221