

DENON

For Europe model

Hi-Fi Component

SERVICE MANUAL

MODEL POA-F100

3 CHANNEL POWER AMPLIFIER

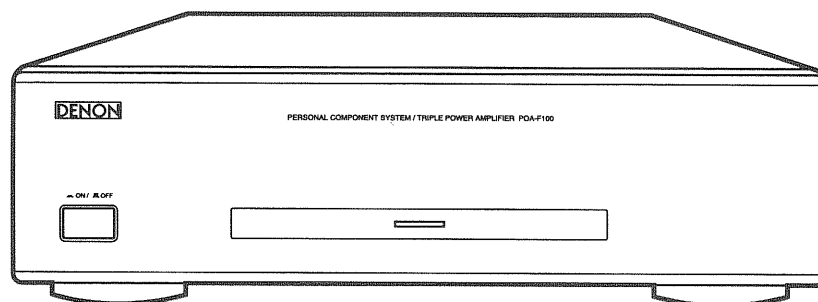

—TABLE OF CONTENTS —

SAFETY PRECAUTIONS	2
SPECIFICATIONS	2
DISASSEMBLY	3,4
ADJUSTMENT	5
BLOCK DIAGRAM	6
LEVEL DIAGRAM	7
SEMICONDUCTORS	8
PRINTED WIRING BOARDS	9
NOTE FOR PARTS LIST	10
PARTS LIST OF P.W.B. UNIT ASS'Y	10,11
EXPLODED VIEW	12
PARTS LIST OF EXPLODED VIEW	13
PACKING VIEW	14
PARTS LIST OF PACKING & ACCESSORIES	14
WIRING DIAGRAM	15
SCHEMATIC DIAGRAM	16

● Some illustrations using in this service manual are slightly different from the actual set.

NIPPON COLUMBIA CO., LTD.

SAFETY PRECAUTIONS

The following check should be performed for the continued protection of the customer and service technician.

LEAKAGE CURRENT CHECK

Before returning the unit to the customer, make sure you make either (1) a leakage current check or (2) a line to chassis resistance check. If the leakage current exceeds 0.5 milliamps, or if the resistance from chassis to either side of the power cord is less than 460 kohms, the unit is defective.

SPECIFICATIONS

Rated output power:	20 W	(6 Ω /ohm Load) 1 kHz, T.H.D. 0.7 %
	25 W	(6 Ω /ohm Load) 1 kHz, T.H.D. 10 %
Total harmonic distortion:	0.08 %	(-3 dB at rated output, 8 Ω /ohms, 1 kHz)
Frequency response:	10 Hz ~ 50 kHz	(+1, -3 dB, at 1 W)
Input sensitivity:	460 mV	(Normal in)
Input impedance:	47 k Ω /kohms	(Normal in)
S/N ratio:	90 dB	(IHF, A-weighting, Normal)
Output terminals:	Speakers:	6 ~ 16 Ω /ohm
Power supply:	AC 230 V, 50 Hz	
Power consumption:	72 W	
Dimensions:	270 (W) \times 84 (H) \times 266 (D) mm (including control knobs and feet)	
Mass:	3.9 kg	

● Specifications and contents are subject to change without notice for purposes of improvement.

DISASSEMBLY

(Follow the procedure below in reverse order when reassembling)

1. Top Cover & Front Panel

(1) Remove 5 screws ① fixing the Top Cover.

(2) Detach the Top Cover as shown in the arrow direction.

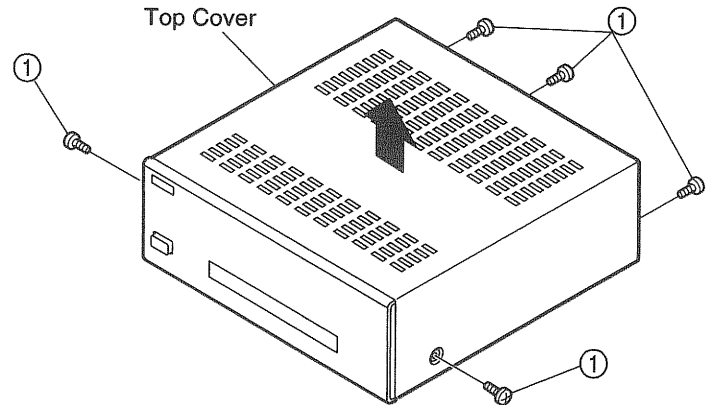

(3) Remove 4 screws ② on the bottom and both sides.

(4) Disconnect 2P LED cable and 2P switch cable from their connector bases.

(5) Pull the Front Panel in the arrow direction with releasing Hooks on the Front Frame from the Chassis, and it comes off with the Front Frame.

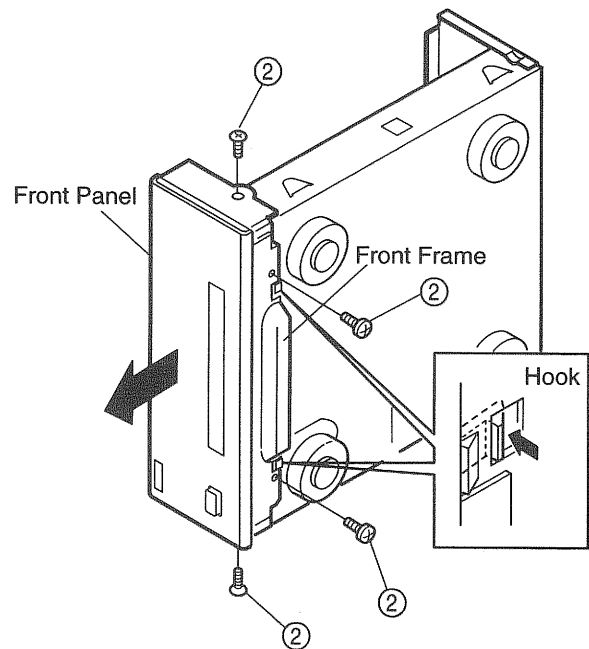

2. P.W.B. on Panel

FRONT P.W.B.

Detach the Front P.W.B. to the arrow direction with releasing 4 Hooks.

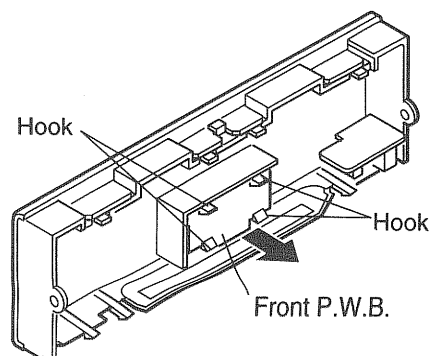

3 Back Chassis

- (1) Take off the Cord Stopper from the Back Chassis.
- (2) Remove 7 screws (3), and detach the Back Chassis to the arrow direction.

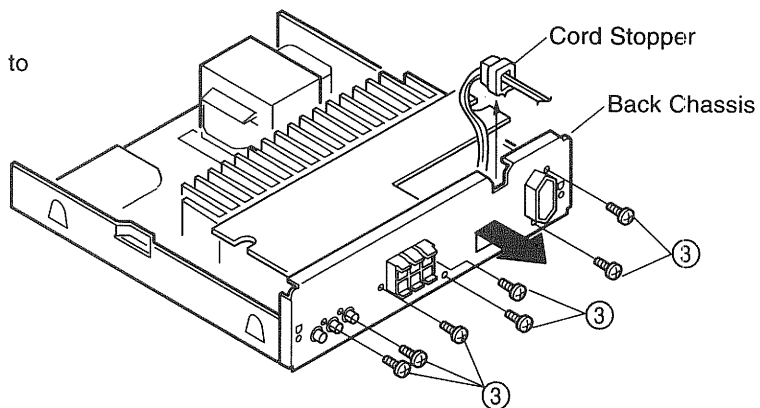

AMP P.W.B.

- (3) Remove 4 screws (4) fixing the Heat Sink Bracket L/R.
- (4) Disconnect 5P and 8P Connector Cord from their connector bases.
- (5) Detach the Amp. P.W.B. with the Main Heat Sink.

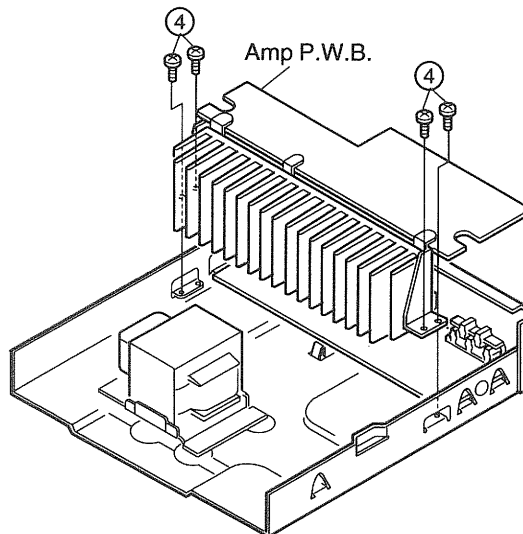

MAIN P.W.B.

- (6) Remove 2 screws (5), and detach the Main P.W.B.

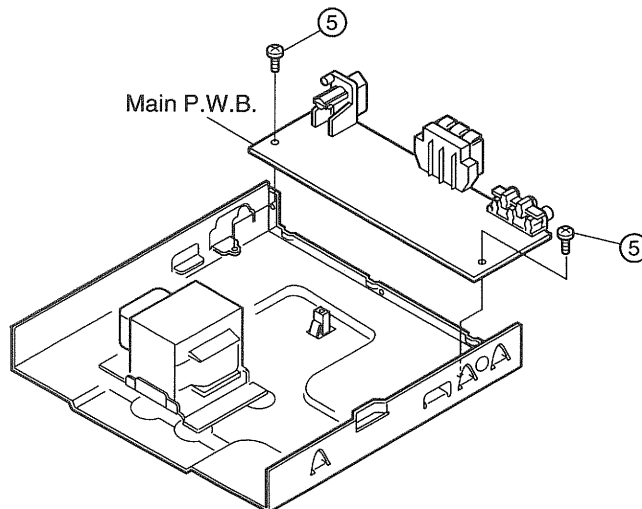

ADJUSTMENT

Idling Current

Required measurement equipment and tool : • DC Voltmeter
• Small screwdriver, 1mm width (-)

Preparation

- (1) Avoid direct blow from an air conditioner or an electric fan, and adjust the unit at normal room temperature 15 °C ~ 30 °C (59 °F ~ 86 °F).
- (2) Presetting
 - POWER (Power source switch) → OFF
 - SPEAKER (Speaker terminal) → No load (Do not connect speaker, dummy resistor, etc.)

Note: The following adjustment should be performed from the foil side of the P.W.B.

Adjustment

- (1) Remove top cover and set SR201, SR101, SR301 on Amp. Unit at the center position.
- (2) Connect DC Voltmeter to test points, Lch: J173(-), J166(+), Rch: J163(-), J154(+), Cch: J147(-), J129(+).
- (3) Connect power cord to AC Line, and turn power switch "ON".
- (4) Within 2 minutes after the power on, turn SR201 to adjust the TEST POINT voltage to 5.5 mV \pm 1.0 mV DC.
- (5) Adjust the Variable Resistors of other channels in the same way.

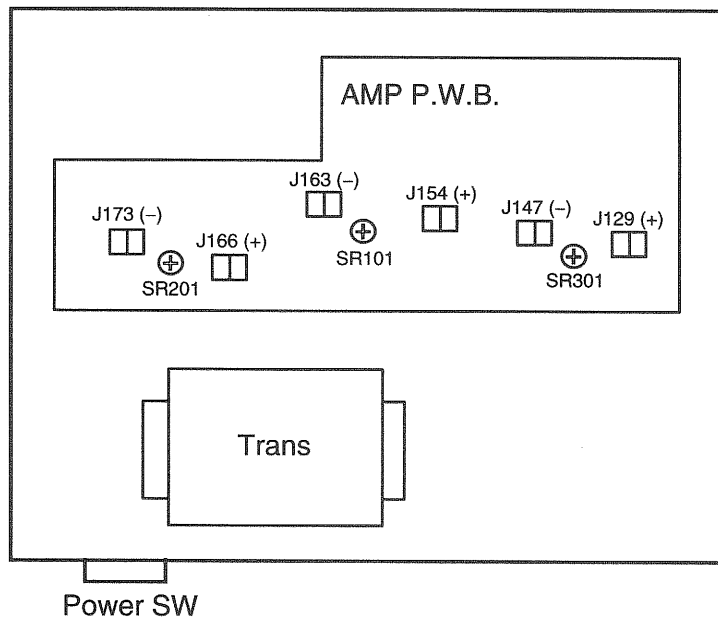

BLOCK DIAGRAMS

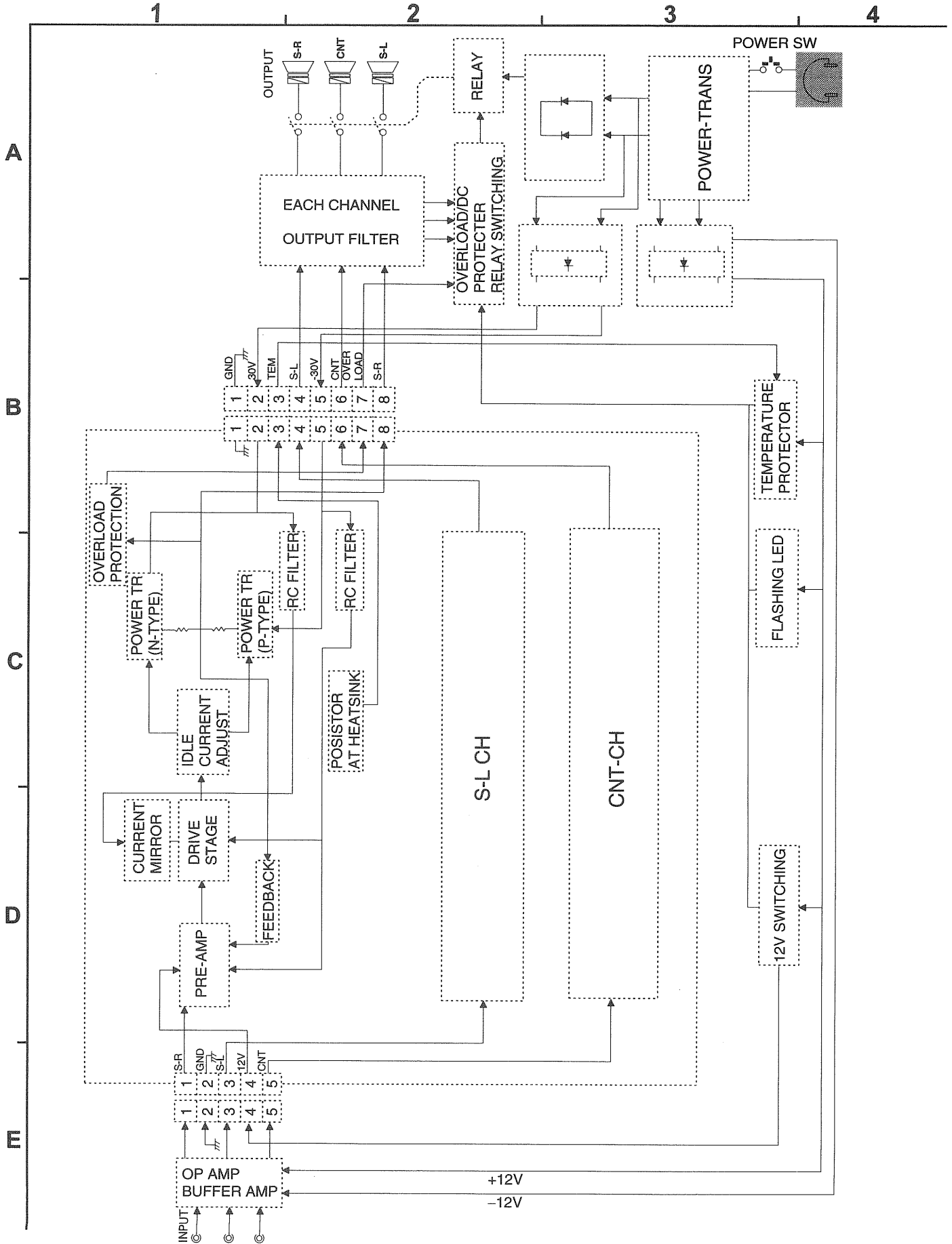

LEVEL DIAGRAM

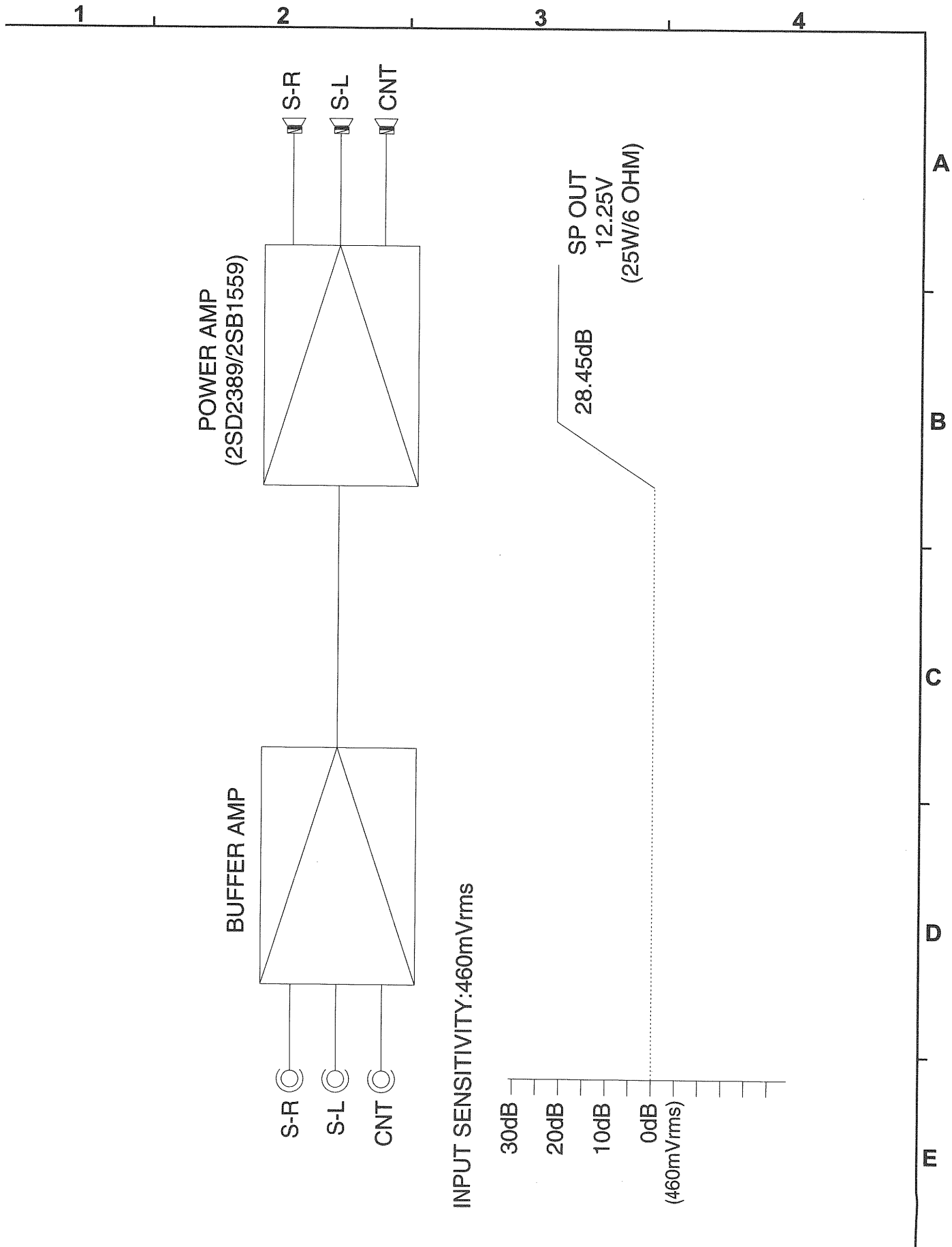

SEMICONDUCTORS

● IC

NJM074D (IC101)

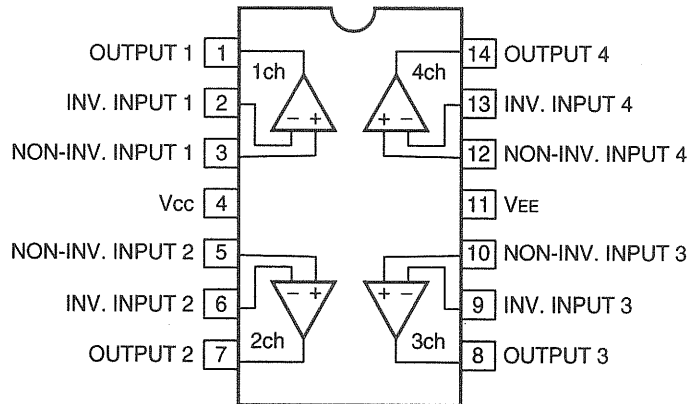

● TRANSISTORS

DTC114YS

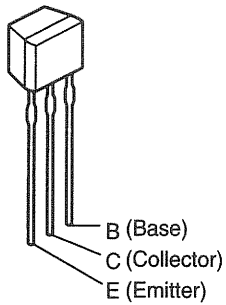

NPN Series

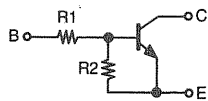

	R1	R2
DTC114YS	10kohm	4.7kohm

KSA992F KSC1845F KTA1266 KTC3198

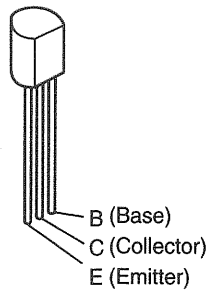

2SC4137

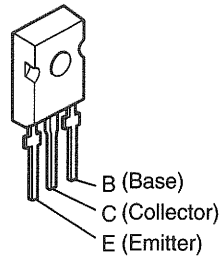

2SB1559 2SD2389

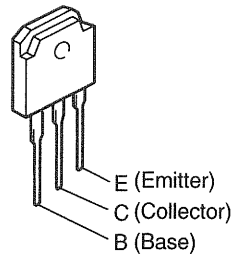

● DIODES

1SS133

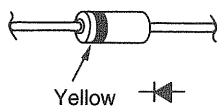

1N4007

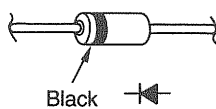

MTZJ12B MTZJ6.2B

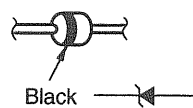

D3SB20

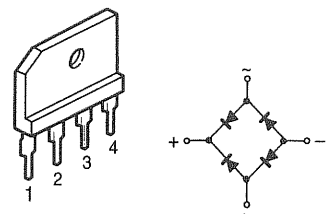

PRINTED WIRING BOARD

9600218617 MAIN P.W.B. ASS'Y

1 2 3 4 5 6 7 8

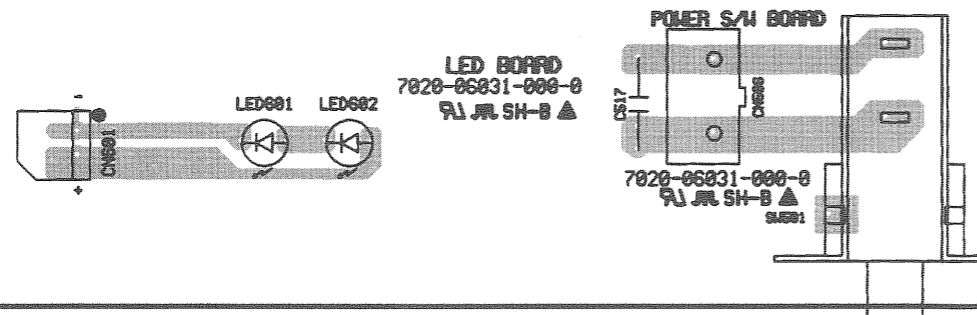
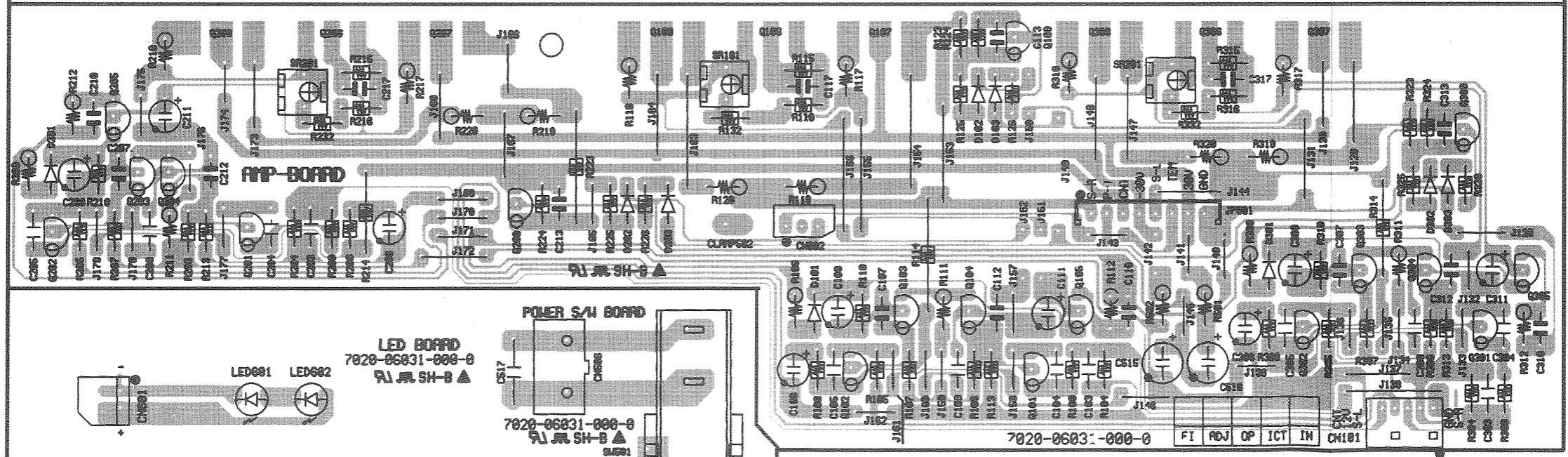
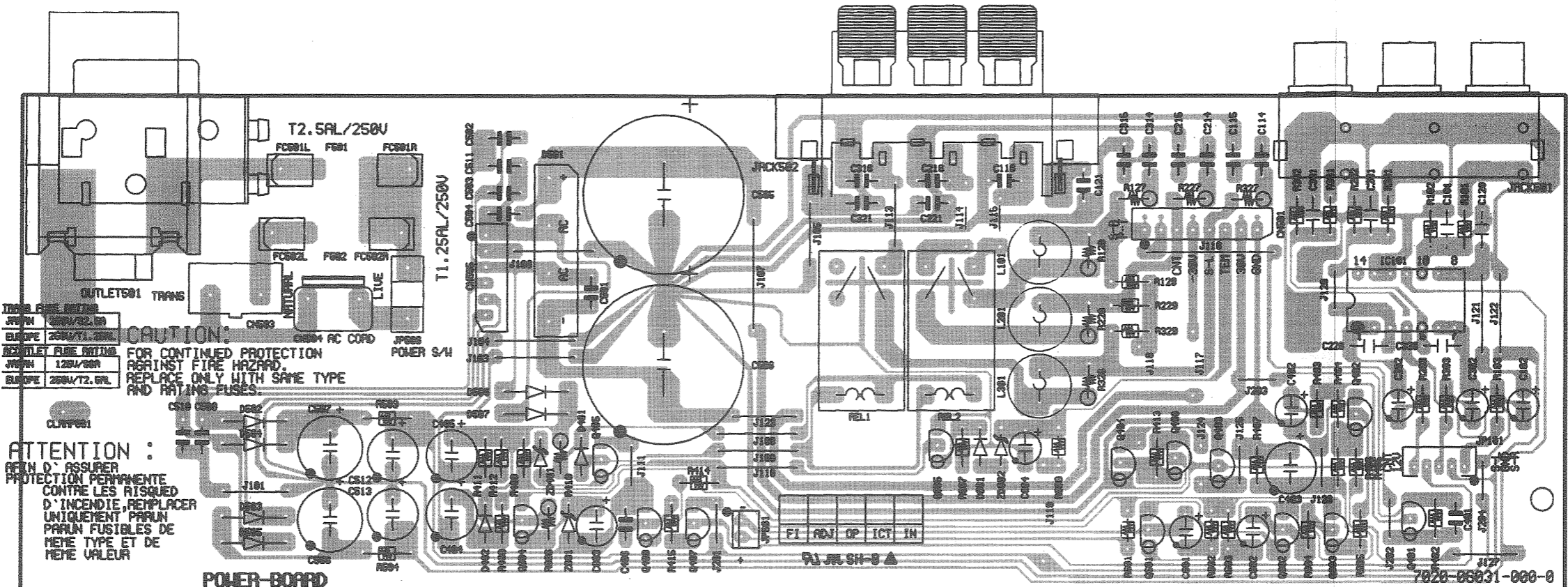

A
B
C
D
E

NOTE FOR PARTS LIST

- Part indicated with the mark "O" are not always in stock and possibly to take a long period of time for supplying, or in some case supplying of part may be refused.
- When ordering of part, clearly indicate "1" and "I" (i) to avoid mis-supplying.
- Ordering part without stating its part number can not be supplied.
- Part indicated with the mark "*" is not illustrated in the exploded view.
- Not including Carbon Film ±5%, 1/4W Type in the P.W.Board parts list. (Refer to the Schematic Diagram for those parts.)

WARNING:
Parts marked with this symbol Δ have critical characteristics.
Use ONLY replacement parts recommended by the manufacturer.

Resistors

Ex.: $\overline{R11}$ 14K 2E 182 G FR

RD : Carbon	2B : 1/8W	F : ±1%	P : Pulse-resistant type
RC : Composition	2E : 1/4W	G : ±2%	NL : Low noise type
RS : Metal oxide film	2H : 1/2W	J : ±5%	NB : Non-burning type
RW : Winding	3A : 1W	K : ±10%	FR : Fuse-resistor
RN : Metal film	3D : 2W	M : ±20%	F : Lead wire forming
RK : Metal mixture	3F : 3W		
	3H : 5W		

* Resistance

$\overline{182}$ ⇒ 1800 ohm = 1.8 kohm
Indicates number of zeros after effective number.
2-digit effective number.

• Units: ohm

$\overline{1R2}$ ⇒ 1.2 ohm
1-digit effective number.
2-digit effective number, decimal point indicated by R.

• Units: ohm

Capacitors

Ex.: CE 04W 1H 2R2 M BP

CE : Aluminum foil electrolytic	0J : 6.3V	F : ±1%	HS : High stability type
CA : Aluminum solid electrolytic	1A : 10V	G : ±2%	BP : Non-polar type
CS : Tantalum electrolytic	1C : 16V	J : ±5%	HR : Ripple-resistant type
CO : Film	1E : 25V	K : ±10%	DL : For change and discharge
CK : Ceramic	1V : 35V	M : ±20%	HF : For assuring high frequency
CC : Ceramic	1H : 50V	Z : +80%	U : UL part
CP : Oil	2A : 100V	-20%	C : CSA part
CM : Mica	2B : 125V	P : +100%	W : UL-CSA type
CF : Metallized	2C : 160V	-0%	F : Lead wire forming
CH : Metallized	2D : 200V	C : ±0.25pF	
	2E : 250V	D : ±0.5pF	
	2H : 500V	= : Others	
	2J : 630V		

* Capacity (electrolyte only)

$\overline{222}$ ⇒ 2200μF
Indicates number of zeros after effective number.
2-digit effective number.

• Units: μF.

$\overline{2R2}$ ⇒ 2.2μF
1-digit effective number.
2-digit effective number, decimal point indicated by R.

• Units: μF.

* Capacity (except electrolyte)

$\overline{222}$ ⇒ 2200pF=0.0022μF
(More than 2) Indicates number of zeros after effective number.
2-digit effective number.

• Units: μF.

$\overline{221}$ ⇒ 220pF
(0 or 1) Indicates number of zeros after effective number.
2-digit effective number.

• Units: pF.

• When the dielectric strength is indicated in AC, "AC" is included after the dielectric strength value.

PARTS LIST OF P.W.B. UNIT MAIN P.W.B. ASS'Y

Ref. No.	Part No.	Part Name	Remarks	Ref. No.	Part No.	Part Name	Remarks
SEMICONDUCTORS GROUP							
IC101	960 0218 905	IC NJM074D	J121074000010	R117,118	960 9004 301	Metal film 47 ohm 1/4W	C060047063050
Q101,102	960 0196 205	Transistor KSA992F	J5000992F0050	R119,120	244 2043 982	Metal oxide 0.22 ohm 1W	C060R22065070
Q103,104	960 0196 506	Transistor KSC1845F	J5021845F0000	R127	244 2043 937	Metal film 10 ohm 1W (NB)	C060010065050
Q105	960 0196 205	Transistor KSA992F	J5000992F0050	R128	963 9003 068	Metal film 4.7 ohm 1/4W (NB)	C0604R7063050
Q109	960 0196 506	Transistor KSC1845F	J5021845F0000	R209		Metal film 220 ohm 1/4W	C060022163050
Q201,202	960 0196 205	Transistor KSA992F	J5000992F0050	R211		Metal film 270 ohm 1/4W (NB)	C060027163050
Q203,204	960 0196 506	Transistor KSC1845F	J5021845F0000	R212		Metal film 220 ohm 1/4W	C060022163050
Q205	960 0196 205	Transistor KSA992F	J5000992F0050	R217,218	960 9004 301	Metal film 47 ohm 1/4W	C060047063050
Q209	960 0196 506	Transistor KSC1845F	J5021845F0000	R219,220	244 2043 982	Metal oxide 0.22 ohm 1W	C060R22065070
Q301,302	960 0196 205	Transistor KSA992F	J5000992F0050	R227	244 2043 937	Metal film 10 ohm 1W (NB)	C060010065050
Q303,304	960 0196 506	Transistor KSC1845F	J5021845F0000	R228	963 9003 068	Metal film 4.7 ohm 1/4W (NB)	C0604R7063050
Q305	960 0196 205	Transistor KSA992F	J5000992F0050	R309		Metal film 220 ohm 1/4W	C060022163050
Q309	960 0196 506	Transistor KSC1845F	J5021845F0000	R311		Metal film 270 ohm 1/4W (NB)	C060027163050
Q401	960 0005 105	Transistor KTA1266Y	J5001266Y0050	R312		Metal film 220 ohm 1/4W	C060022163050
Q402	960 0196 506	Transistor KSC1845F	J5021845F0000	R317,318	960 9004 301	Metal film 47 ohm 1/4W	C060047063050
Q403,404	960 0005 202	Transistor KTC3198 (Y)	J5023198Y0000	R319,320	244 2043 982	Metal oxide 0.22 ohm 1W	C060R22065070
Q405	960 0196 904	Transistor DTC114YS (NPN)	J6020114Y0050	R327	244 2043 937	Metal film 10 ohm 1W (NB)	C060010065050
Q406,407	960 0196 205	Transistor KSA992F	J5000992F0050	R328	963 9003 068	Metal film 4.7 ohm 1/4W (NB)	C0604R7063050
Q408	960 0005 202	Transistor KTC3198 (Y)	J5023198Y0000	R410	960 9003 807	Metal film 100 ohm 1/4W	C060010163050
Q601,602	960 0196 506	Transistor KSC1845F	J5021845F0000	R501,502	960 9004 301	Metal film 47 ohm 1/4W	C060047063050
Q603	960 0196 205	Transistor KSA992F	J5000992F0050	R606		Metal film 2.2 kohm 1/4W (NB)	C060022263520
Q604,605	960 0005 202	Transistor KTC3198 (Y)	J5023198Y0000	SR101,201	960 0221 109	Semi fixed resistor 1 kohm	C541102115000
D101-103	963 0020 309	Diode 1SS133T	K000013300520	SR301	960 0221 109	Semi fixed resistor 1 kohm	C541102115000
D201-203	963 0020 309	Diode 1SS133T	K000013300520	CAPACITORS GROUP			
D301-303	963 0020 309	Diode 1SS133T	K000013300520	C101		Ceramic 68pF/50V	D001680067520
D401,402	963 0020 309	Diode 1SS133T	K000013300520	C102		Electrolytic 1μF/50V	D040010087080
D501	960 0039 508	Diode D3SB20/DBF40C	K047004000010	C103		Ceramic 100pF/50V	D005101177520
D502-507	963 0058 407	Diode 1N4007	K000400700520	C104		Ceramic 330pF/50V	D005331277520
D601	963 0020 309	Diode 1SS133T	K000013300520	C105		Ceramic 100pF/50V	D005101177520
ZD401,601	963 0058 601	Zener diode MTZJ12B	K06012R044520	C106		Electrolytic 100μF/10V	D040101082060
ZD602	960 0095 704	Zener diode MTZJ6.2B	K06006R244520	C107		Ceramic 82pF/50V	D000820167050
LED601,602	960 0219 001	LED HL30CNB RED	K500032000090	C108		Electrolytic 1μF/100V	D040010086060
RESISTORS GROUP				C109		Ceramic 8.2pF/50V	D0018R2077530
R109		Metal film 220 ohm 1/4W	C060022163050	C110		Ceramic 220pF/50V	D004221067060
R111		Metal film 270 ohm 1/4W (NB)	C060027163050	C111		Electrolytic 22μF/35V	D040220085050
R112		Metal film 220 ohm 1/4W	C060022163050	C112		Ceramic 82pF/50V	D000820167050
				C113		Ceramic 0.022μF/50V	D004223597050
				C114,115	963 0021 900	Mylar film 0.047μF/100V	D02047306C060
				C116		Mylar film 0.0047μF/100V	D02047206C060
				C117		Ceramic 0.01μF/50V	D004103277050
				C120		Ceramic 3.3pF/50V	D0013R3077520
				C121		Ceramic 0.0047μF/50V	D004472277050
				C201		Ceramic 68pF/50V	D001680067520

Ref. No.	Part No.	Part Name	Remarks
C202		Electrolytic 1μF/50V	D040010087080
C203		Ceramic 100pF/50V	D005101177520
C204		Ceramic 330pF/50V	D005331277520
C205		Ceramic 100pF/50V	D005101177520
C206		Electrolytic 100μF/10V	D040101082060
C207		Ceramic 82pF/50V	D000820167050
C208		Electrolytic 1μF/100V	D040010086060
C209		Ceramic 8.2pF/50V	D0018R2077530
C210		Ceramic 220pF/50V	D004221067060
C211		Electrolytic 22μF/35V	D040220085050
C212		Ceramic 82pF/50V	D000820167050
C213		Ceramic 0.022μF/50V	D004223597050
C214,215	963 0021 900	Mylar film 0.047μF/100V	D02047306C060
C216		Mylar film 0.0047μF/100V	D02047206C060
C217		Ceramic 0.01μF/50V	D004103277050
C220		Ceramic 3.3pF/50V	D0013R3077520
C221		Ceramic 0.0047μF/50V	D004472277050
C301		Ceramic 68pF/50V	D001680067520
C302		Electrolytic 1μF/50V	D040010087080
C303		Ceramic 100pF/50V	D005101177520
C304		Ceramic 330pF/50V	D005331277520
C305		Ceramic 100pF/50V	D005101177520
C306		Electrolytic 100μF/10V	D040101082060
C307		Ceramic 82pF/50V	D000820167050
C308		Electrolytic 1μF/100V	D040010086060
C309		Ceramic 8.2pF/50V	D0018R2077530
C310		Ceramic 220pF/50V	D004221067060
C311		Electrolytic 22μF/35V	D040220085050
C312		Ceramic 82pF/50V	D000820167050
C313		Ceramic 0.022μF/50V	D004223597050
C314,315	963 0021 900	Mylar film 0.047μF/100V	D02047306C060
C316		Mylar film 0.0047μF/100V	D02047206C060
C317		Ceramic 0.01μF/50V	D004103277050
C320		Ceramic 3.3pF/50V	D0013R3077520
C321		Ceramic 0.0047μF/50V	D004472277050
C401		Mylar film 0.01μF/100V	D02010306C060
C402		Electrolytic 10μF/35V	D040100085100
C403		Electrolytic 220μF/6.3V	D040221081050
C404		Electrolytic 220μF/25V	D040221084060
C405		Electrolytic 100μF/35V	D040101085050
C406	963 9003 152	Mylar film 0.068μF/100V	D02068306C060
C501*504		Ceramic 0.01μF/500V	D00410359D050
C505,506		Electrolytic 4700μF/50V	D040472087000
C507,508		Electrolytic 470μF/35V	D040471085100
C509,510		Ceramic 0.01μF/500V	D00410359D050
C511		Metalized 0.1μF/250V	D02310407H150
C512,513		Electrolytic 100μF/35V	D040101085050
C515,516		Electrolytic 47μF/50V	D040470087060
C517	960 0177 208	Ceramic 0.0047μF/ 250V (AC)	D00847208K03D

Ref. No.	Part No.	Part Name	Remarks
C601,602		Electrolytic 33μF/16V	D042330083050
C603		Electrolytic 10μF/35V	D040100085100
C604		Electrolytic 10μF/16V	D040100083100
OTHER PARTS GROUP			
CLAMP501	—	Wire clamp	4330000120000 1
CN101	960 0213 023	5P connector base	L101530150510 1
CN501	960 0118 801	8P connector base	L102526700800 1
CN503	960 0123 304	2P connector base	L104353280200 1
CN504	960 0118 908	2P connector base	L108039602010 1
CN505	960 0128 804	6P connector base	L102526700600 1
CN506	960 0123 304	2P connector base	L104353280200 1
CN601	960 0219 302	2P connector base	L102526800200 1
CN602	960 0123 207	3P connector base	L102526700300 1
△ F501	960 0142 602	Fuse 2.5A	G650252251160 1
△ F502	960 0142 505	Fuse 1.25A	G650122251160 1
△ FC501L,R	960 0005 804	Fuse clip	G645000050010 2
△ FC502L,R	960 0005 804	Fuse clip	G645000050010 2
JACK501	960 0221 002	3P pin jack	G606030164030 1
JACK502	960 0218 808	6P speaker terminal	G596040340000 1
JP101	960 0219 904	5P connector cord	L000085050010 1
JP501	960 0219 917	8P connector cord	L000900080010 1
JP506	960 0219 221	2P connector cord	L000301020010 1
JP601	960 0219 920	2P connector cord	L000401020040 1
L101,201	960 0005 008	Inductor 0.15μH	D330R15000000 2
L301	960 0005 008	Inductor 0.15μH	D330R15000000 1
△ OUT501	960 0143 203	AC outlet	G435040110000 1
REL1,2	960 0181 702	Relay (G5PA-28 24V)	G680240502020 2
SW501	960 0219 409	Push switch	G000000050010 1

EXPLODED VIEW

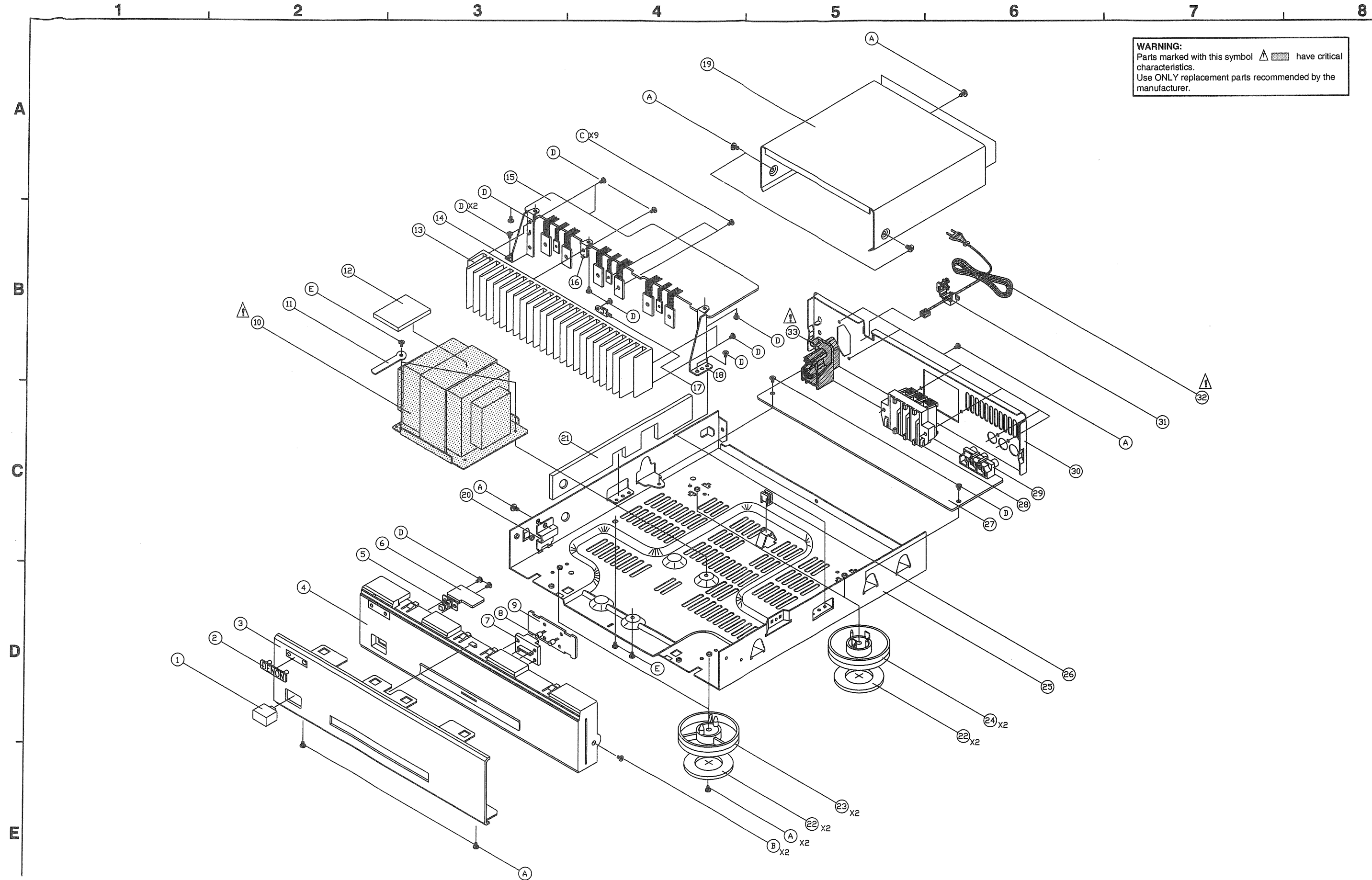

WARNING:
Parts marked with this symbol  have critical characteristics.
Use **ONLY** replacement parts recommended by the manufacturer.

WIRING DIAGRAM

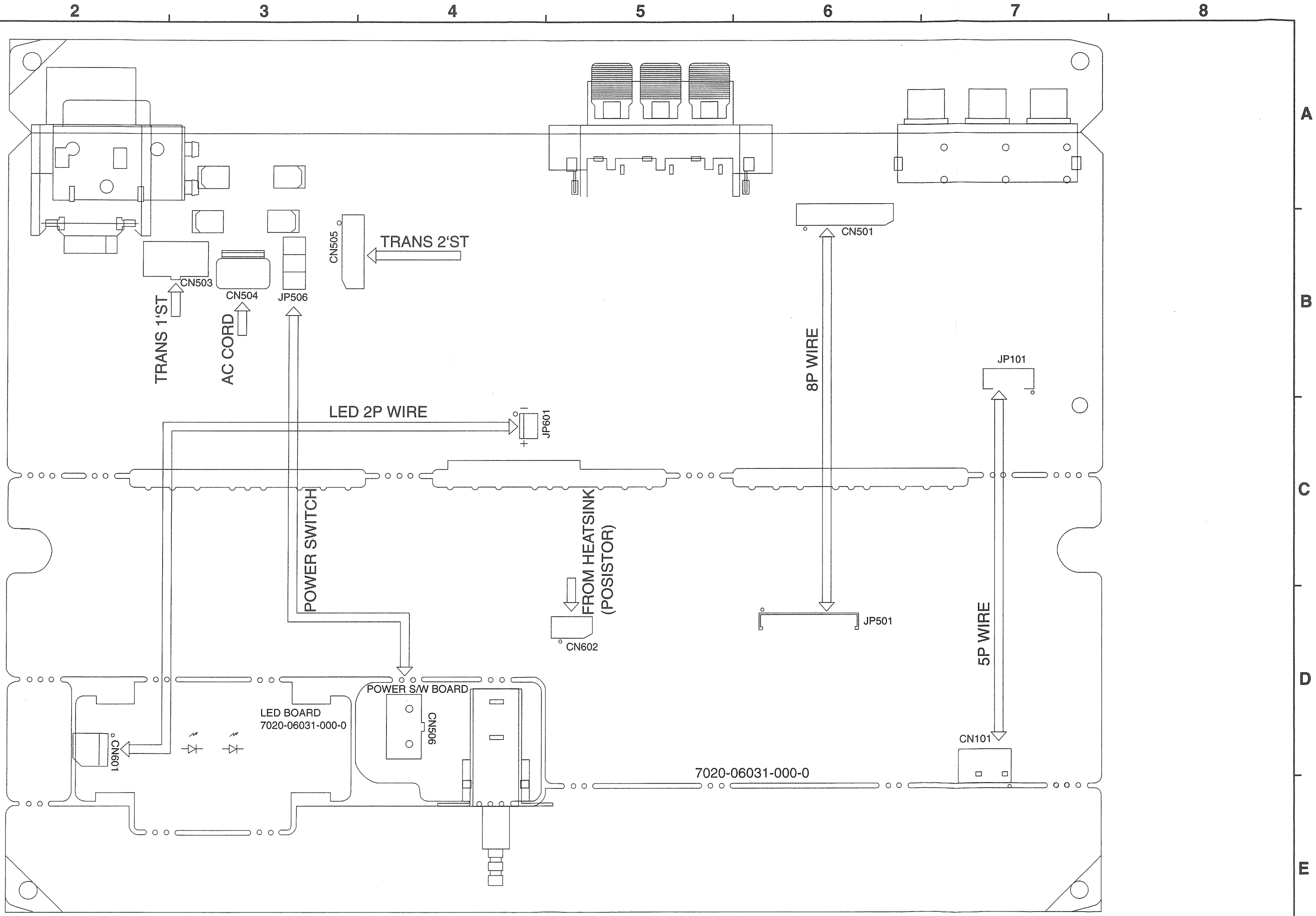

SCHEMATIC DIAGRAM

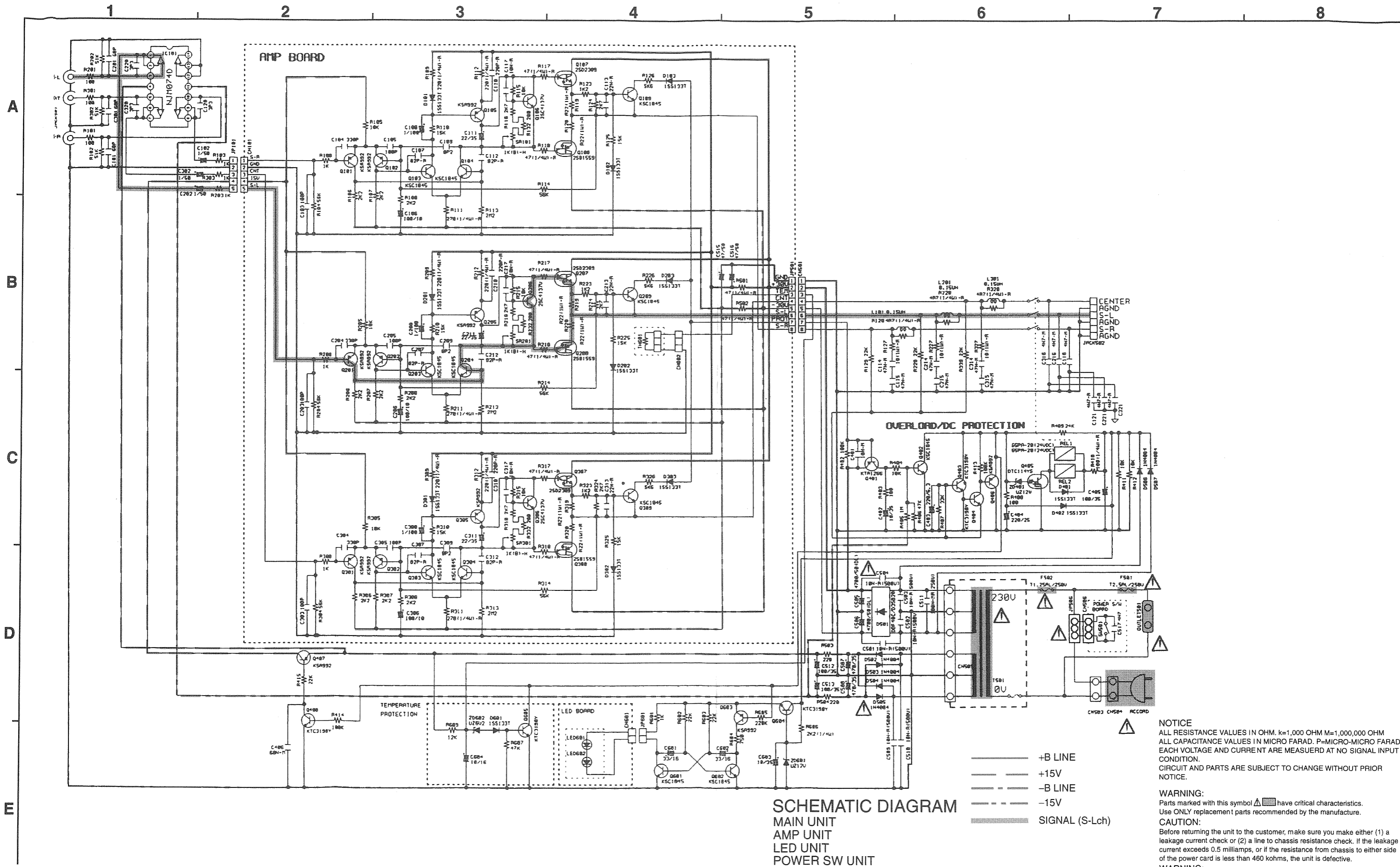

SCHEMATIC DIAGRAM
 MAIN UNIT
 AMP UNIT
 LED UNIT
 POWER SW UNIT

NOTICE
 ALL RESISTANCE VALUES IN OHM. k=1,000 OHM M=1,000,000 OHM
 ALL CAPACITANCE VALUES IN MICRO FARAD. P=MICRO-MICRO FARAD
 EACH VOLTAGE AND CURRENT ARE MEASURED AT NO SIGNAL INPUT
 CONDITION.
 CIRCUIT AND PARTS ARE SUBJECT TO CHANGE WITHOUT PRIOR
 NOTICE.

WARNING:
 Parts marked with this symbol have critical characteristics.
 Use ONLY replacement parts recommended by the manufacture.

CAUTION:
 Before returning the unit to the customer, make sure you make either (1) a
 leakage current check or (2) a line to chassis resistance check. If the leakage
 current exceeds 0.5 milliamperes, or if the resistance from chassis to either side
 of the power card is less than 460 kohms, the unit is defective.

WARNING:
 DO NOT return the unit to the customer until the problem is located and
 corrected.

PARTS LIST OF EXPLODED VIEW

Ref. No.	Part No.	Part Name	Remarks	Q'ty	Ref. No.	Part No.	Part Name	Remarks	Q'ty
	960 0218 617	Main P.W.B ass'y	7025MM9901010	1	SCREWS				
27		Main P.W.B		1	A	960 0108 604	Screw (2S 3×8 BK/BH)	B020030083B10	17
15		AMP P.W.B		1	B	960 9008 006	Screw (2S 3×8 BK/FH)	B020030083F10	2
9		LED P.W.B		1	C	963 0048 404	Screw (2S 3×16 ZNY/HH)	1507041146010	9
6		POWER SW P.W.B		1	D	963 0018 007	Screw (2S 3×8 ZNY/BH)	B020030081B10	17
1	960 0208 009	Power button	5097210791000 for Gold model	1	E	960 9008 417	Screw (3S 4×8 ZNY/BH)	B028940081B10	4
1	960 0208 012	Power button	5097210791100 for Black model	1					
2	960 0115 707	DENON badge	5630210008000 for Gold model	1					
2	960 0115 710	DENON badge	5630210008010 for Black model	1					
3	960 0217 809	Front panel	3067210048300 for Gold model	1					
3	960 0217 812	Front panel	3067210048310 for Black model	1					
4	960 0218 109	Front frame	3217210101000 for Gold model	1					
4	960 0218 112	Front frame	3217210101100 for Black model	1					
5	960 0219 409	Push switch	G000000050010 SW501	1					
7	960 0218 206	LED indicator	5160210053000	1					
8	960 0219 001	LED HL30CNB RED	K500032000090 LED601,602	2					
10	960 0218 714	Power trans	8200660550050	1					
11	—	Wire clamp	4330040213010	1					
12	960 0219 506	Trans cushion	4050210195000	1					
13	—	Heat sink	2120210198000	1					
14	960 0219 603	Heat sink bracket L	4010210536000	1					
16	960 0221 604	PWB bracket	4010055806010	1					
17	960 0221 206	Posistor	F320550001010	1					
18	960 0219 616	Heat sink bracket R	4010210546000	1					
19	960 0217 702	Top cover	3000210006300 for Gold model	1					
19	960 0217 715	Top cover	3000210006400 for Black model	1					
20	960 0221 303	Safety bracket	4010210556000	1					
21	960 0219 700	Main cushion	4050210215000	1					
22	960 0003 505	Foot cushion	4050020075010	4					
23	960 0003 408	Foot	4007000061010	2					
24	960 0115 008	Foot	4000210001000	2					
25	960 0221 507	Chassis	3200210086200	1					
26	960 0003 301	PCB supporter	4070001601010	1					
28	960 0218 808	6P speaker terminal	G596040340000 JACK502	1					
29	960 0221 002	3P pin jack	G606030164030 JACK501	1					
30	960 0217 919	Back panel	3207210016400	1					
31	960 0135 305	Cord stopper	4380040162010	1					
△	960 0165 304	AC cord assy	L0668040011010	1					
△	960 0143 203	AC outlet	G435040110000 OUT501	1					

PACKING VIEW

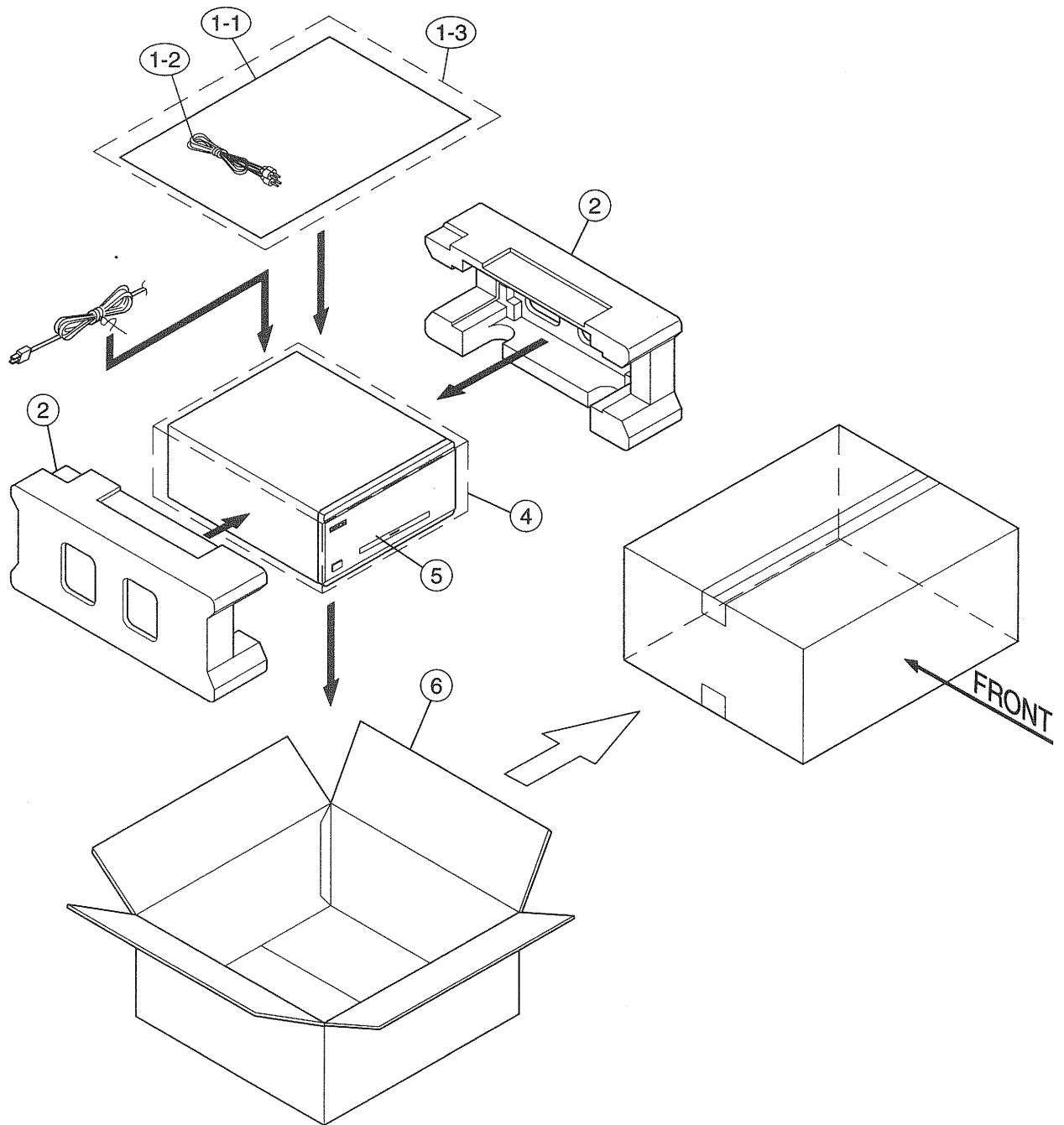

PARTS LIST OF PACKING & ACCESSORIES

Ref. No.	Part No.	Part Name	Remarks	Q'ty	Ref. No.	Part No.	Part Name	Remarks	Q'ty
1-1	960 0218 413	Instruction manual	5707210370000	1	★	—	Control label	5500014920010	2
1-2	960 0219 108	3P pin cord	L063310200000	1	★	—	EAN label	5507005000010	2
1-3	960 0107 809	Poly bag	6337000240010	1				for Gold model	
2	960 0116 007	Cushion ass'y	6230210014000	1	★	—	EAN label	5507005000020	2
4	960 0116 104	Set poly bag	6337200029010	1				for Black model	
5	—	POA-F100							
6	960 0218 510	Carton case	6007210010000	1					