

DENON

Hi-Fi Component/Tuner

For European Model

SERVICE MANUAL MODEL TU-767 AM-FM STEREO TUNER

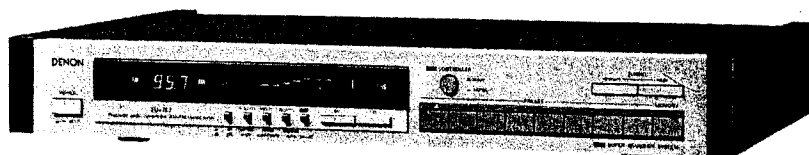

TABLE OF CONTENTS

SPECIFICATIONS	2
CONTROLS AND THEIR DESCRIPTION	3
BLOCK DIAGRAM	3
CONNECTIONS	4~5
METHOD OF ADJUSTMENTS	6~8
SEMICONDUCTORS	8~10
PRINTED WIRING BOARD PATTERNS AND PARTS LIST	
ETC0658J TRAP UNIT	10
ETC0660N DISPLAY UNIT	10
ETC0659L TUNER UNIT	11
CONNECTION DIAGRAM	12
WIRING DIAGRAM	13
EXPLODED VIEW OF CHASSIS AND CABINET	14

NIPPON COLUMBIA CO., LTD.

SPECIFICATIONS

FM SECTION

Frequency Range: 87.5 ~ 108 MHz
Antenna Terminals: 75 ohm unbalanced
Practical Sensitivity: 0.9 μ V (10.3 dBf)
S/N 50 dB Sensitivity: Stereo: 15.8 μ V (35.2 dBf)
 Monaural: 1.5 μ V (14.2 dBf)
 0 dBf at 10⁻¹⁵W (new IHF Standard)
Image Interference Ratio: 90 dB
IF Interference Ratio: 100 dB
AM Suppression Ratio: 65 dB
Effective Selectivity: Wide = 50 dB
 Narrow = 60 dB (\pm 300 kHz)
Capture Ratio: 1.0 dB
Frequency Characteristics: 20 Hz to 15 kHz +0.2
 -1.5 dB
Signal-to-noise Ratio: Monaural: 88 dB
 Stereo: 82 dB
Total Harmonic Distortion: Monaural
 (at 75 kHz deviation)
 1 kHz 0.03%
 Stereo
 (at 67.5 kHz deviation)
 1 kHz 0.04%
Stereo Separation: 1 kHz 57 dB
Muting Operating Level: 20 dB
Output Level (at 75 kHz deviation): 0.6 V
AM SECTION (MW)
Frequency Range: 522 ~ 1611 kHz

Antenna Terminal: With Loop Antenna
Usable Sensitivity: 18 μ V
Selectivity: 55 dB
Image Interference Ratio: 45 dB
Signal-to-noise Ratio: 55 dB
Total Harmonic Distortion: 0.3%
Output Level (at 30% modulation): 0.2 V

LEVEL CHECKING SIGNAL

Frequency: 440 Hz
Output Level: 0.3 V
Electric Field Strength Indication: by 7 LED's (Green)

OTHERS

Power Supply: AC 220 V/50 Hz
Power Requirement: AC 11 W
Dimensions: 434 mm (17.1")W x 66 mm (2.6") H x
 281 mm (11.1")D
Net Weight: 3.6 kg (7.94 lbs.)

Design and specifications subject to change without notice.

CONTROLS AND THEIR DESCRIPTION

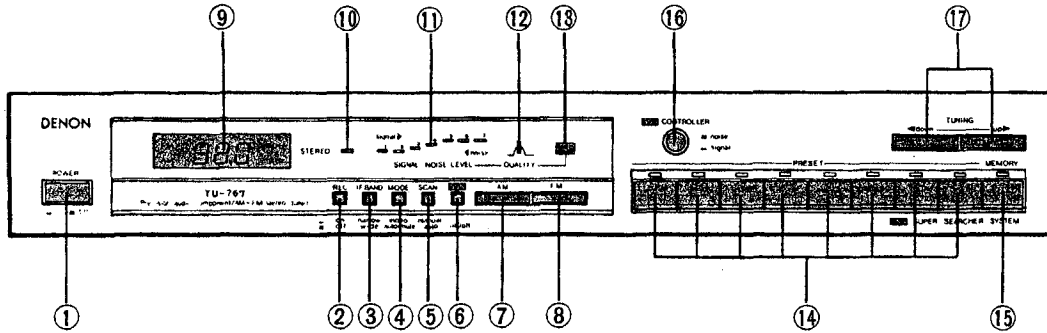

Fig. 1

- ① POWER (Power on/standby Switch)
Note: The power switch contains an ON/OFF indicator (except in models exported to Europe)
- ② REC (Recording Level Switch)
- ③ IF BAND (IF Band Selector Switch)
- ④ MODE (Mode Switch)
 ▶ Auto/Mute, ◀ Mono
- ⑤ SCAN (Tuning Mode Select Switch)
 ▶ Auto, ◀ Manual
- ⑥ SSS ON/OFF (See Page 8 for Details Regarding the Super Searcher System-[SSS])
- ⑦ AM
- ⑧ FM
- ⑨ DIGITAL FREQUENCY INDICATOR
- ⑩ STEREO (Stereo Indicator)
- ⑪ SIGNAL/NOISE LEVEL
 ▶ Signal, ◀ Noise
- ⑫ QUALITY (Quality Indicator)
- ⑬ SSS (Super Searcher System Indicator)
- ⑭ PRESET CHANNEL 1 ~ 8 (Station Presetting Buttons)
- ⑮ MEMORY (Memory Button)
- ⑯ SSS CONTROLLER (Super Searcher System Control Knob)
- ⑰ TUNING (Tuning Buttons)
 ▶ Up, ◀ Down

BLOCK DIAGRAM

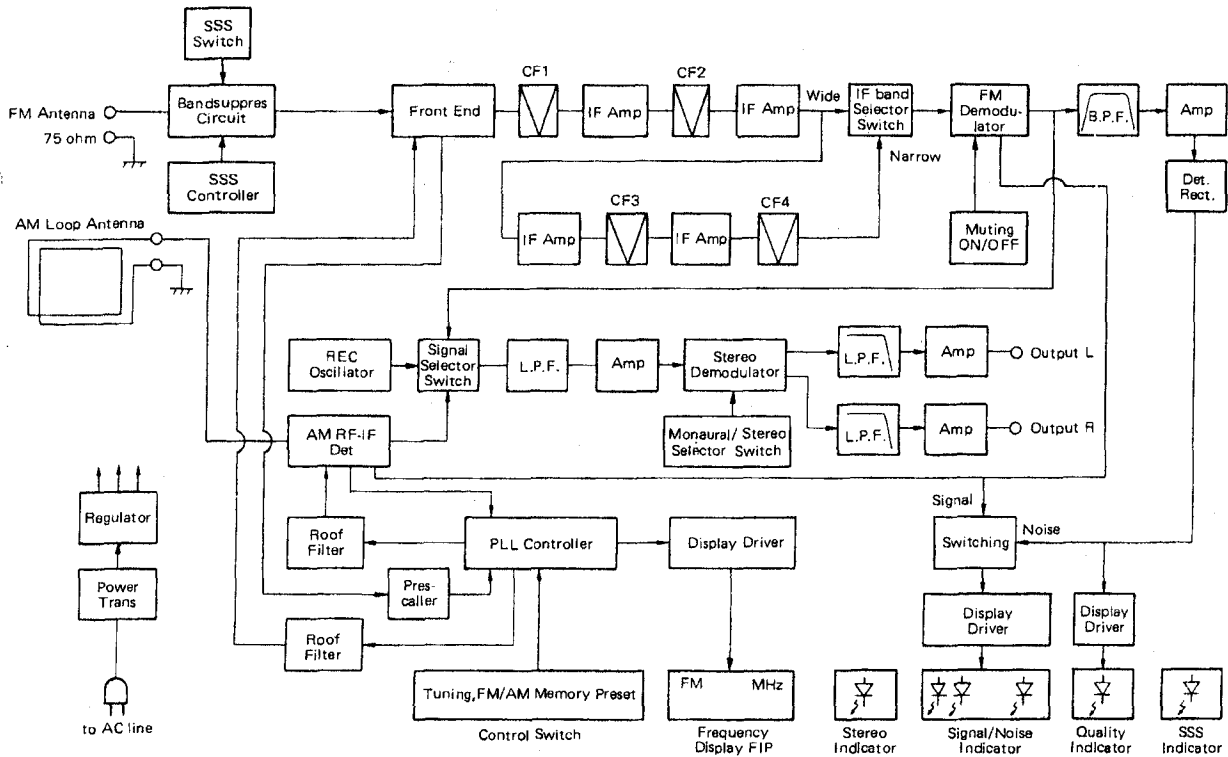

Fig. 2

CONNECTIONS

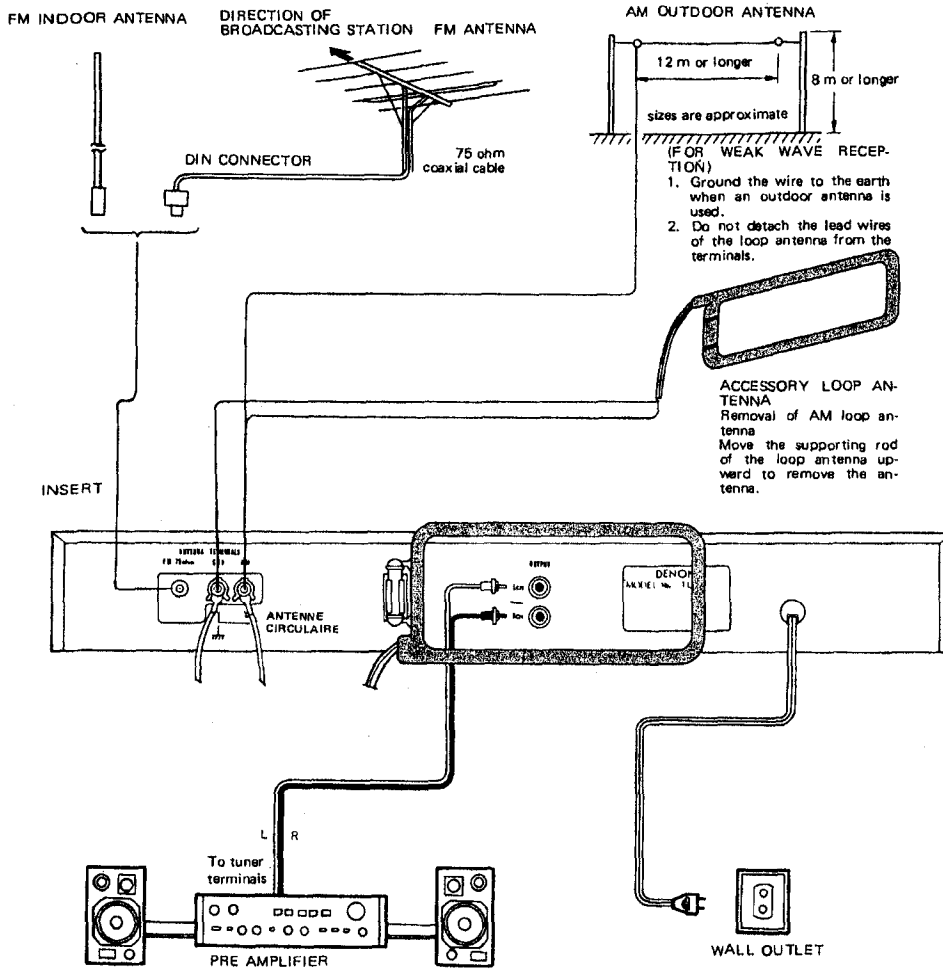

Fig. 3

PRECAUTIONS ON CONNECTIONS

Do not plug the cord into an AC outlet until all connections of the unit are completed.

● **CONNECTION WITH AUDIO AMPLIFIER**

Connect the pin cord (supplied) between the OUTPUT terminals of the tuner and the "tuner" input terminals of the audio amplifier. Be careful to connect the left (L) and right (R) channels of the output terminals to the corresponding left (L) and right (R) channels of the "tuner" input terminals. (Set the volume control of the audio amplifier to minimum).

- Do not bundle or wind the pin plug and the power source cord together, and do not place the pin cord near the power transformer; otherwise, hum noise may result.
- Insert the plugs into the corresponding jacks firmly because incomplete connections cause electric field noise.

ANTENNA INSTALLATION

● FM OUTDOOR ANTENNA CONNECTION (Fig. 4)

75 ohm coaxial cable (3C-2V, 5C-2V) is preferable to obtain better performance of the tuner.

* Contact your local dealer for details on selection and installation of the FM outdoor antenna.

* When a 300 ohm FM antenna is connected by a 75 ohm coaxial cable, a matching transformer is required.

● AM ANTENNA CONNECTION (Fig. 5)

Since the model is provided with a high performance AM loop antenna on the back panel, this accessory antenna can effectively be used for optimal reception in places where broadcasting stations are located nearby and relatively strong signals are received with low noise.

Orient the loop antenna horizontally to obtain optimal reception.

In places where strong, clear signals are not received due to particular location and/or environmental conditions, connect an insulated wire to the AM antenna terminals and attach it to the wall. In places where broadcasting stations are located too far away and only weak signals are received, or where signals are blocked by obstacles, install an AM outdoor antenna.

* Even if an AM outdoor antenna is installed, do not detach the AM loop antenna.

GROUNDING

If there is much noise during reception, it is recommended that a grounding wire be used.

Connect a thick insulated wire to the "GND" terminal, and wind the unconnected bare end around a metal water pipe, a grounding rod, or a grounded copper plate.

* Never connect grounding the wire to a gas pipe. This could cause fire or explosion.

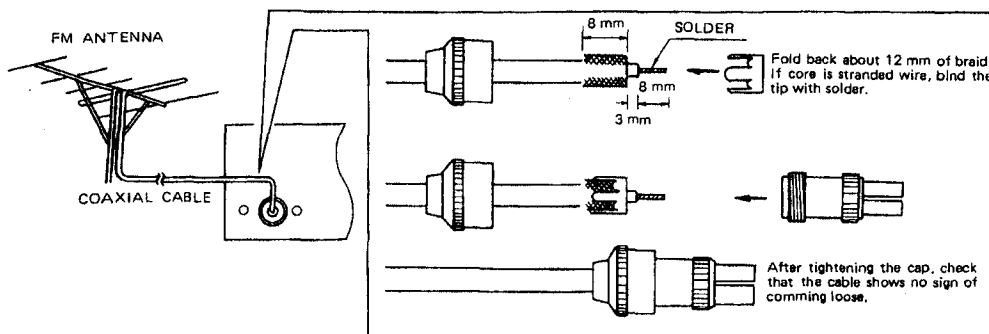

Fig. 4

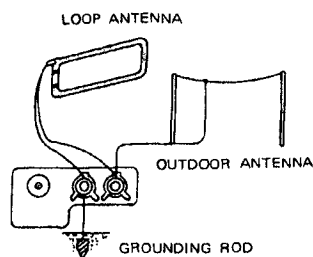

Fig. 5

METHOD OF ADJUSTMENTS

When marking adjustments, be sure the power supply is at the rated voltage and the room air is in normal condition with respect to temperature and humidity.

ADJUSTMENT OF RF TRAP UNIT (ETC0658J) (SSS on, MODE → mono)

Table 1

Adjustment Item	Tuning	Input Side				Output Side			Adjustment Point	Adjustment Value
		Measuring Instrument	Frequency	Input Level	Modulation	Connection Point	Measuring Instrument	Connection Point		
1 88 MHz Tracking Check	88.0 MHz	FM SSG	88.0 MHz	Variable depending on output waveform attenuation	Mono 1 kHz 100%	Antenna Terminal	Digital Voltmeter	VC. G	—	3 V ± 10 mV at the time of adjustment to the max. point of output waveform attenuation using the SSS controller
2 108 MHz Tracking Check	108.0 MHz	FM SSG	108.0 MHz	Variable depending on output waveform attenuation	Mono 1 kHz 100%	Antenna Terminal	Digital Voltmeter	VC. G	—	20 V ± 100 mV at the time of adjustment to the max. point of output waveform attenuation using the SSS controller
3	If NG in items 1 and 2, advance to items 4 to 6									
4 108 MHz Tracking	108.0 MHz	FM SSG	108.0 MHz	Variable depending on output waveform attenuation	Mono 1 kHz 100%	Antenna Terminal	Oscilloscope	Output (L)	TC1	Output waveform attenuation is max. at 20 V ± 50 mV
5 88 MHz Tracking	88.0 MHz	FM SSG	88.0 MHz	Variable depending on output waveform attenuation	Mono 1 kHz 100%	Antenna Terminal	Oscilloscope	Output (L)	L1	Output waveform attenuation is max. at 3 V ± 5 mV
6	Repeat the adjustment in items 4 and 5 so that the waveform attenuation is maximum at the rated voltage									
7 Adjustment of Attenuation	98.0 MHz	FM SSG	98.0 MHz	Variable depending on output waveform attenuation	Mono 1 kHz 100%	Antenna Terminal	Oscilloscope	Output (L)	VR1	Adjust to max. attenuation after adjustment to the max. point of output waveform attenuation using the SSS controller

Normal Output Waveform

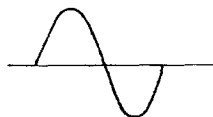

Distortion of Output Waveform due to Input Attenuation

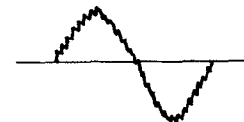

Fig. 6

Adjustment item	Tuning	Input Side					Output Side		Adjustment Point	Adjustment Value	Remarks
		Measuring instrument	Frequency	Input Level	Modulation	Connection Point	Measuring instrument	Connection Point			
1 76 kHz	98.0 MHz	FM SSG	98.0 MHz	60 dBμ	Mono 1 kHz, 100%	Antenna Terminal	Frequency Counter	TP-3, 4	VR 201	76 kHz ± 50 Hz	
2 Center Adjustment	98.0 MHz	FM SSG	98.0 MHz	60 dBμ	Mono 1 kHz, 100%	Antenna Terminal	Tuning Meter Jig	TP-1, 2	T2	Tuning Meter Center	IF μ wide
3 Mono Distortion	98.0 MHz	FM SSG	98.0 MHz	60 dBμ	Mono 1 kHz, 100%	Antenna Terminal	Distortion Meter	Output (L)	T3	Min. Distortion	IF μ wide
4 Stereo Distortion	98.0 MHz	FM SSG	98.0 MHz	60 dBμ	Stereo (L) 1 kHz Main Pilot 90% 10%	Antenna Terminal	Distortion Meter	Output (L)	Front End IFT	Min. Distortion	IF μ wide
5 Tuning Center Distortion Adjustment	Repeat items 2 to 4 so that the tuning meter may indicate its center value, and the distortion is minimum at tuning time										
6 IC402 Offset Adjustment	98.0 MHz	FM SSG	98.0 MHz	60 dBμ	Mono 1 kHz, 100%	Antenna Terminal	DC Voltmeter	TP-5, GND	VR 401	100 ± 10 mV	By SSS controller in μ noise mode
7 Noise indicator LED ON Level	98.0 MHz	FM SSG	98.0 MHz	-3 dBμ	Mono 1 kHz, 100%	Antenna Terminal	-	-	VR 402	7th Noise LED ON	By SSS controller in μ noise mode
8 Signal indicator LED ON Level	98.0 MHz	FM SSG	98.0 MHz	1st Signal LED OFF	Mono 1 kHz, 100%	Antenna Terminal	-	-	VR 4	Quality LED ON	By SSS controller in μ noise mode
9 Quality indicator LED ON Level	98.0 MHz	FM SSG	98.0 MHz	50 dBμ	Mono 1 kHz, 100%	Antenna Terminal	-	-	VR 403	7th Signal LED ON	By SSS controller in μ noise mode
10 REC Level Output Adjustment	98.0 MHz	FM SSG	98.0 MHz	60 dBμ	Mono 1 kHz, 100%	Antenna Terminal	Valve Voltmeter	Output (L)	VR 3	-8 dB ± 1 dB of 100% Output	REC μ on
11 Pilot Cancell	98.0 MHz	FM SSG	98.0 MHz	60 dBμ	Stereo (L) Pilot 10%	Antenna Terminal	Valve Voltmeter	Output (L)	VR 202	Min. Pilot Leakage	19/38 kHz L.P.F. is not used
12 Separation	98.0 MHz	FM SSG	98.0 MHz	60 dBμ	Stereo (L) 1 kHz Main Pilot 90% 10%	Antenna Terminal	Valve Voltmeter	Output (L) Output (R)	VR 203	Max. Separation (Balance of directivity)	19/38 kHz L.P.F. is used
13 IF Narrow Distortion Adjustment	98.0 MHz	FM SSG	98.0 MHz	60 dBμ	Stereo (L) 1 kHz Main Pilot 90% 10%	Antenna Terminal	Distortion Meter	Output (L)	T1	Min Distortion	IF μ narrow
14 IF Narrow Gain Adjustment	98.0 MHz	FM SSG	98.0 MHz	1st Signal LED ON when wide	Stereo (L) 1 kHz Main Pilot 90% 10%	Antenna Terminal	-	-	VR 1	Equalization of 1st signal LED ON level at wide/narrow switching time	IF μ narrow
15 IF Narrow Distortion Check	98.0 MHz	FM SSG	98.0 MHz	60 dBμ	Stereo (L) Mono	Antenna Terminal	Distortion Meter	Output (L)	-	Mono Under 0.7 Stereo Under 1%	If standard value cannot be obtained, repeat items 13 and 14

AM

1 IF Adjustment	No. broad-casting Frequency	AM IF Sweep	-	No-IF Waveform Distortion Level	-	AM Antenna Terminal	Monitor Scope	R 311	T 303	Flat at Max. IF Waveform	
2 522 kHz Tuning Voltage	522 kHz	-	-	-	-	-	Digital Voltmeter	R 301	T 305	1.2 V ± 20 mV	
3 1611 kHz Tuning Voltage	1611 kHz	-	-	-	-	-	Digital Voltmeter	R 301	TC 303	8 V ± 100 mV	
4	Repeat items 2 and 3 to obtain rated tuning voltage										
5 603 kHz Tracking	603 kHz	AM SSG	603 kHz	Non-AGC Level	400 Hz, 30%	Loop Antenna	Valve Voltmeter	Output (L)	T 301	Max. Output	Adjust the SG output not to undergo AGC
6 1404 kHz Tracking	1404 kHz	AM SSG	1404 kHz	Non-AGC Level	400 Hz, 30%	Loop Antenna	Valve Voltmeter	Output (L)	TC 301	Max. Output	Adjust the SG output not to undergo AGC
7	Repeat items 5 and 6 to adjust the tracking										
8 Signal Indicator LED ON Level	999 kHz	AM SSG	999 kHz	70 dBμ/m	400 Hz, 30%	Loop Antenna	-	-	VR 401	7th Signal LED ON	

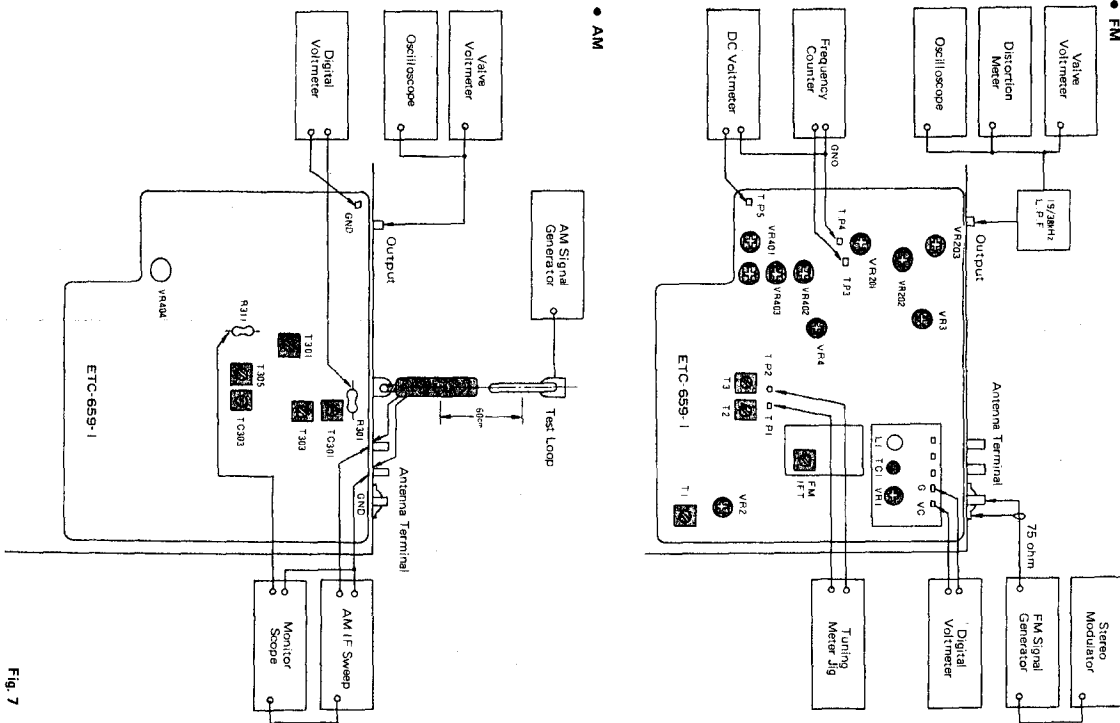

Fig. 7

CONNECTION DIAGRAM OF MEASURING INSTRUMENTS

ROUGH DIAGRAM OF ADJUSTMENT POINTS

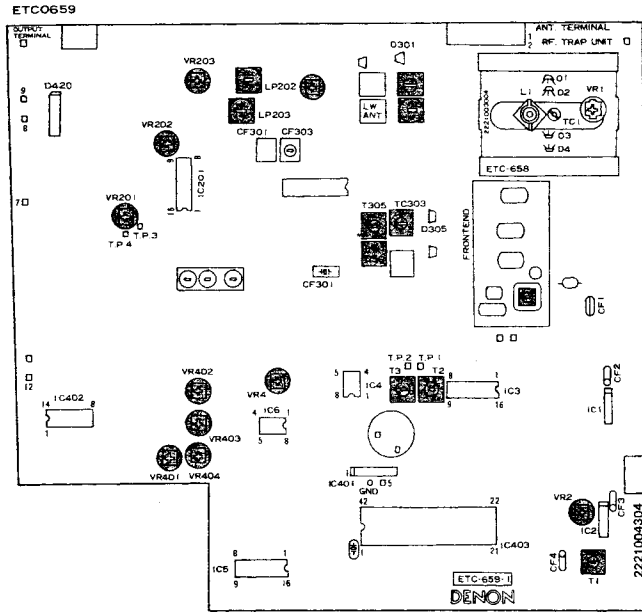

Fig. 8

TUNING METER JIG

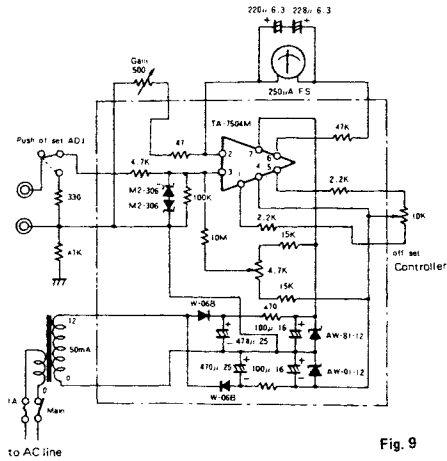

Fig. 9

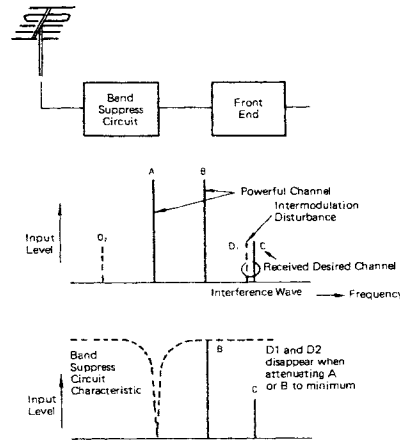

Fig. 10

PRINCIPLE OF SUPER SEARCHER SYSTEM (SSS)

If two or more powerful stations are on the FM band, unexpected radio waves are generated in an area between them. This is called "intermodulation disturbance". When receiving a station near these generated waves, a ragged sound or other disturbing noises occur.

Fig. 10 explains this situation. Intermodulation components D1 and D2 are generated by stations A and B, disturbing the desired reception station C.

Interference wave D1 cannot be separated from the wave of station C. However, by removing this disturbance caused by A and B with the band suppress circuit, D1/D2 will disappear.

Operation:

If the signal indicator (green) is lit, but the quality indicator is disturbance is present, Turn ON the SSS switch, and set the SSS controller to (■) noise mode. Adjust the SSS controller volume so that the noise level indicator (red) shows the minimum value.

* Band suppress circuit = RF trap filter (Frequency variable)

** If another station has been selected, the SSS is rest automatically.

SEMICONDUCTORS

• IC's

• NJM4558D (JRC)

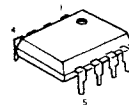

HA112223W
HA12412
(Hitachi)



HA112223W

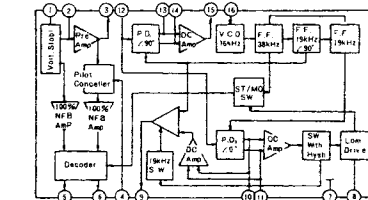

HD14027B (Hitachi)

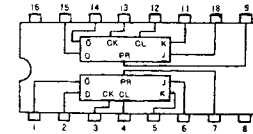

HA12412

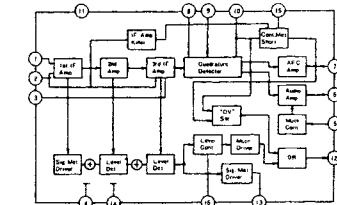

TA7060AP (Toshiba)

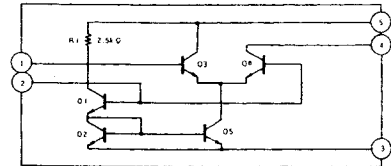
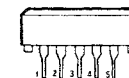

TD6301AP
(Toshiba)

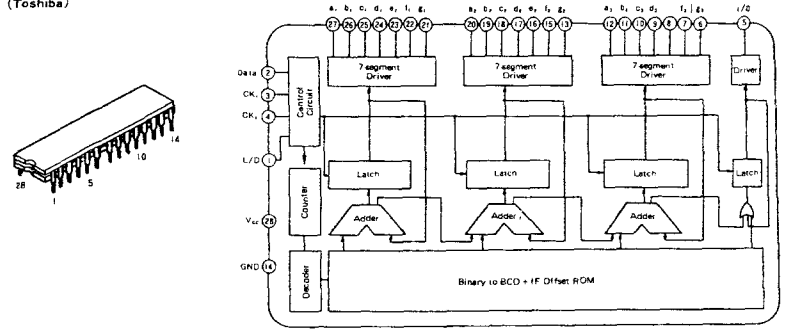

FUNCTIONS OF TERMINALS

Pin No.	Name	Function	Pin No.	Name	Function
1	L/D	Output status select input terminal. Input terminal for selecting output status by the indicator (LED, FL, LCD).	6~12	a ³ ~g ³	7-segment drive output terminal. 10 MHz-unit display at FM time. 100 kHz-unit display at AM time.
2	Data	Receiving frequency data input terminal. Input serially by the system controller LSI.	13, 15~20	a ² ~g ²	7-segment drive output terminal. 1 MHz-unit display at FM time. 10 kHz-unit display at AM time.
3, 4	CK1 CK2	Receiving frequency data input control timing input terminal. Transferred simultaneously with data by the system controller LSI.	21~27	a ¹ ~g ¹	7-segment drive output terminal. 100 kHz-unit display at FM time. 1 kHz-unit display at AM time.
5	I/O	Segment drive output terminal. 100 MHz-unit display at FM time. Only 1 pin is used for output because of 1 to 0 in both FM/AM.	14, 28	Vcc GND	Supply voltage applying terminal.

FUNCTIONS OF TERMINALS

Pin No.	Name	Functions
5	f _{IN}	FM station signal input terminal. Frequency range 80 ~ 140 MHz. Input level 75 ~ 300 mVrms.
3	OUT-1	Dividing an input signal into 1/30 or 1/32 through dividing output terminal f _{IN} . Output level 0.5(V)MIN.
2	OUT-2	OUT-1 inverted signal output. Because of open emitter system, if it is to be used, external resistor is necessary. Open in general.
7	PSC	Dividing value select control terminal. 1/32 when Vpcc ≧ 2(V), 1/30 when Vpcc ≦ 1(V).
6	C	for bias circuit. Connect C = 2200 pF (approx.) between the unit and the GND.
1	Vcc	Power terminal Vcc = 5V
4	GND	Ioc = 5 mA (standard), 10 mA (max.)

TD6104P
(Toshiba)

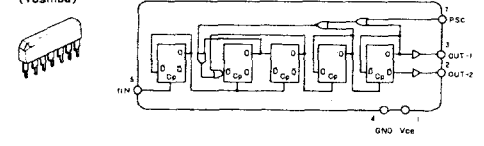

LB1417
(Sanyo)

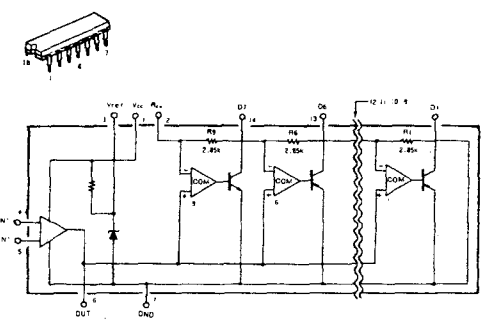

LA1245
(Sanyo)

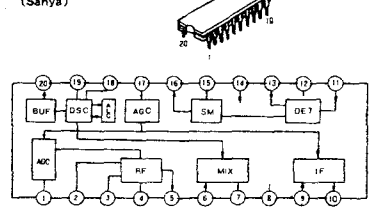

TC9147P
(Toshiba)

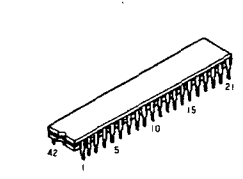

FUNCTIONS OF TERMINALS

Pin No.	Symbol	Name	Function
2	XT	Crystal oscillator terminal	Connects crystal 7.2 MHz for reference frequency.
3	XT	Crystal oscillator terminal	Connects crystal 7.2 MHz for reference frequency.
4	FM	FM band specifying input	Selects FM, MW and LW in the mutual reset mode.
5	MW	MW band specifying input	
6	LW	LW band specifying input	
7	MANUAL	Manual tuning mode specifying input	Selects between manual operation and auto search operation in mutual reset mode at UP/DOWN channel select time.
8	AUTO	Auto search tuning mode specifying input	UP/DOWN channel selection by connecting a push-key.
9	UP	UP operation key input	UP/DOWN channel selection by connecting a push-key.
10	DOWN	DOWN operation key input	UP/DOWN channel selection by connecting a push-key.
11	STD	Memory store instruction input	With this input, preset memory is set to write enable status.
12 ~ 19	M1 ~ M8	Preset memory channel specifying input	Controls read/write of the internal 16-channel preset memory in conjunction with MC1 and MC2 input.
20	MC1	Memory control input	Sets the 16-channel preset memory to an 8-channel fixed system for FM/AM (MW + LW) or a 16-channel tandem system for FM+MW+LW (3 bands).
21	MC2		
22	OSC2	Oscillator terminal for AM	C/R connecting terminal for oscillator, which determines scan speed at AM search time.
23	OSC1	Oscillator terminal for FM	C/R connecting terminal for oscillator, which determines scan speed at FM search time.
24	O/5	FM Europe 50 kHz output	Europe area FM band 50 kHz step indicating output. Set "H" at 50 kHz.
25	CK2	Received frequency data serial output	Outputs serial data and timing lock to driver TD6301 for receiving frequency digital display. CK1 output is used as Pcc output at the same time.
26	CK1		
27	DATE		

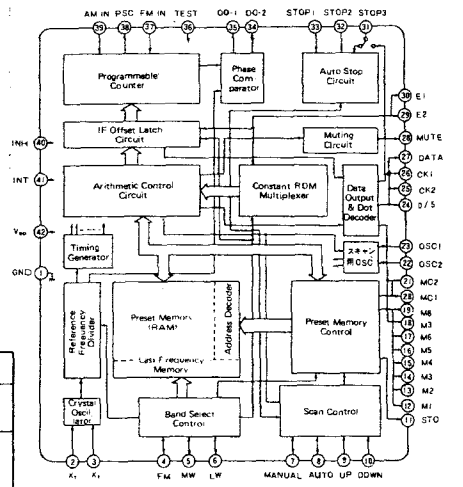

Pin No.	Symbol	Name	Function
28	MUTE	Muting signal output	Set "H" at muting output time.
29	E2	Area specify input	Specifies an area, Japan, U.S.A. or Europe.
30	E1		
31	STOP3	AM-IF signal input	Counts IF 450 kHz signals at AM time and stops auto search.
32	STOP2	Auto search stop signal input	If "H" level is input STOP2 when "H" level is set to STDPI, the auto search is stopped. Used for ARI or stereo channel receiving status discrimination.
33	STOP1	Scan speed slow input	When "H" level is input, reduces the auto search scan speed to 1/2.
34	DO-2	Phase comparator output	Two tristate buffers are output in parallel from a single phase comparator.
35	DO-1	Phase comparator output	Two tristate buffers are output in parallel from a single phase comparator.
36	TEST	Test terminal	Sets test mode with "H" level input.
37	FM/IN	FM programmable counter input	Connects the output of precaller TD6104P.
38	PSC	Precaller control output	Controls dividing (1/30, 1/32) of the precaller TD6104P.
39	AM/IN	FM programmable counter input	Inputs AM channel signal.
40	INH	inhibit input	Ordinary operation at "H" level, and inhibit status at "L" level.
41	INT	Initialize input	Ordinary operation at "H" level, and initialization of internal status at "L" level.
42	VOD	Power applying terminal	Applies 5 ± 0.5 V. Up to 2 V is available as backup.
1	GND		

• TRANSISTORS

25C461 (C)
25C1815 (BL)
25A1015 (GR)

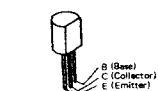

SEL1123R (Red)
SEL1323G (Green)
LN31GPHL

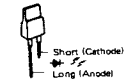

25D880 (Y)

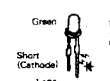
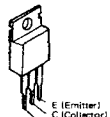

25D882 (G/P)

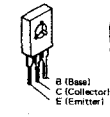

FET 25K163M

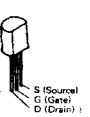

• DIODES (including LED)

1S2076



Varactor
SVC321SP-D2



GL-5NP5



1N60



Twin Varactor
SVC211SP-B



1. Anode (Yellowish Green)
2. Cathode (Common)
3. Anode (Red)



HZ6-B2
HZ7C-2
HZ-15-3
HZ-9B-2

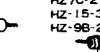

S1VB20

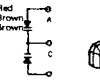

• ELECTRON RAY INDICATOR TUBE

FIP7A8S

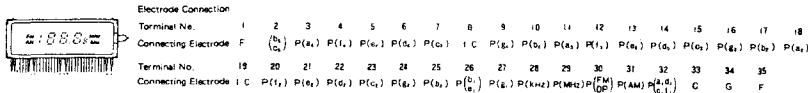
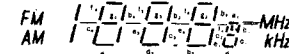

PRINTED WIRING BOARD PATTERNS AND PARTS LIST

ETC060N DISPLAY UNIT

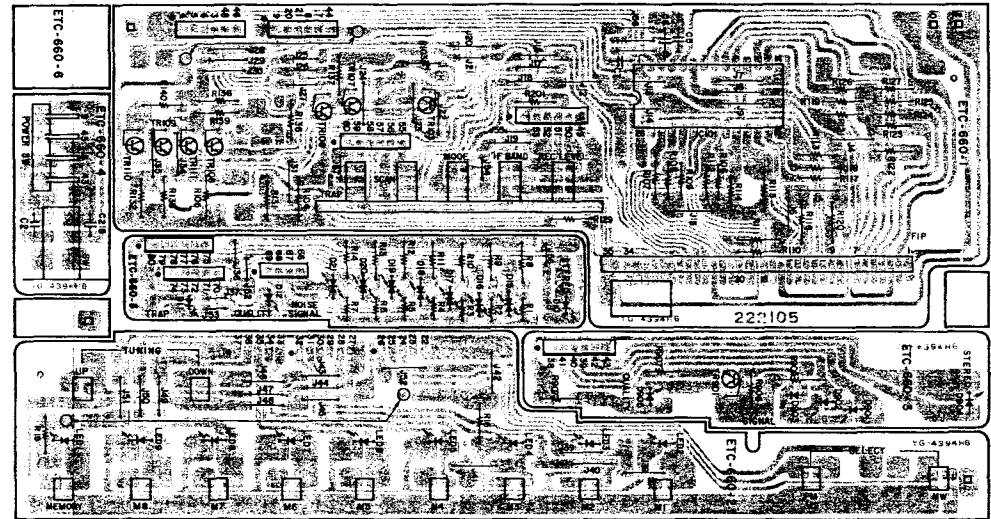

ETC0658J TRAP UNIT

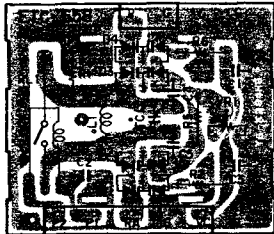

ETC0658J TRAP UNIT PARTS LIST

Ref. No.	Part No.	Part Name & Descriptions	Ref. No.	Part No.	Part Name & Descriptions
SEMICONDUCTOR					
D001 ~004	2760366008	SVC211SP3 VARACTOR	C004 005	2533469006	10PF ±5% 50V CERAMIC
RESISTORS					
VR001	EP-5462H11	SOLID VOLUME 4.7 k ohm	L001	RT-11653	FM OSC COIL
R001 002	2412148008	220 k ohm ±5% 1/4W CARBON FILM	OTHER PARTS		
R005	2412089002	750 ohm ±5% 1/4W CARBON FILM		2221003004	P.W. BOARD
R006	2412148008	220 k ohm ±5% 1/4W CARBON FILM		2140052000	REED RELAY
CAPACITORS					
TC001	2130034009	TRIMMER CONDENSER (CTZ-51C)		2050087026	2P TERMINAL
C002 003	2531024003	0.01µF +80, -20% 50V CERAMIC		2050087055	5P TERMINAL
				4140328004	SHIELD CASE

NOTE: If D001, D002, D003 and D004 are to be replaced, be sure to replace them in pairs.

ETC060N DISPLAY UNIT PARTS LIST

Ref. No.	Part No.	Part Name & Descriptions	Ref. No.	Part No.	Part Name & Descriptions
SEMICONDUCTORS					
IC001	2620453006	TD6301 AP (TOSHIBA) IC	SWITCHES		
TR103	2730198015	2SC1815 (BL) TRANSISTOR	2124456004		1P PUSH SWITCH (POWER)
TR106 ~111	2730198015	2SC1815 (BL) TRANSISTOR	2124457003		5P PUSH SWITCH (FUNCTION)
D001	3939165000	SEL1323G (GREEN) LED	2124407008		TACT SWITCH USED 13
D002 ~009	3939165013	SEL1123R (RED) LED	OTHER PARTS		
D010	3939236007	SEL1110W (RED) LED	2221005002		P.W. BOARD
D011	3939238005	SEL2413E (C/D)(GREEN) LED	2090008146		JUMPER WIRE P = 5 mm USED 3
D012	3939239004	LN31GPHL (GREEN) LED	2090008120		JUMPER WIRE P = 10 mm USED 48
D015 ~021	3939237006	GL5NP5 (B/C) (RED/GREEN) LED	2090008117		JUMPER WIRE P = 12.5 mm USED 1
	3934011007	FIP7A8S FLD	EP-5667H1		TERMINAL PIN USED 3
RESISTORS (not included Carbon Film ±5%, 1/4W Type)					
R001 ~007	2412334016	1.8 k ohm ±5% 1/6W CARBON FILM	2050092040		4P WRAPPING TERMINAL USED 1
CAPACITORS					
C002	2531024003	0.01µF +80 -20% 50V CERAMIC	2038107025		5P CONNECTOR CORD USED 1
C005 ~007	2531006005	2200PF ±10% 50V CERAMIC	20400094029		6P CONNECTOR CORD USED 2
C215	2531024003	0.01µF +80% 50V CERAMIC	2040094016		6P CONNECTOR CORD USED 1
			2042056010		9P CONNECTOR CORD USED 1
			2046024006		11P CONNECTOR CORD USED 1
			2048017039		12P CONNECTOR CORD USED 1
			2050185064		5P WIRE HOLDER USED 1
			2050185067		6P WIRE HOLDER USED 5
			2050185041		4P WIRE HOLDER USED 1

Ref. No.	Part No.	Part Name & Descriptions
C425	2544132005	10 μ F 16V ELECTROLYTIC
C426	2544164031	220 μ F \pm 20% 25V ELECTROLYTIC
C427	25441511002	22 μ F 50V ELECTROLYTIC
C428	2544086009	2200 μ F \pm 20% 25V ELECTROLYTIC
C429	2531024003	0.01 μ F \pm 80% 50V CERAMIC
C431	2531024003	0.01 μ F \pm 80% 50V CERAMIC
C432	2544161047	470 μ F 6.3V ELECTROLYTIC
C433	2531024003	0.01 μ F \pm 80% 50V CERAMIC
C434	2544129005	47 μ F 10V ELECTROLYTIC
C435	2531024003	0.01 μ F \pm 80% 50V CERAMIC
C437	2544151002	22 μ F 50V ELECTROLYTIC
C438	2544132005	10 μ F 16V ELECTROLYTIC
C439	2544140000	4.7 μ F 35V ELECTROLYTIC
C901	2531024003	0.01 μ F \pm 80% 50V CERAMIC
TC301	2130022008	TRIMMER CONDENSER
TC303	2130022008	TRIMMER CONDENSER
COIL, TRANS.		
T001	2312048004	FM IFT
T002	2312901002	FM IF DET (A)
T003	2312902001	FM IF DET (B)
T301	2311061008	MW ANT. TRANS
T303	2310050001	AM IFT
T305	2311076103	NW OSC COIL
L002	TRTD565H1	INDUCTOR (2.2 μ H)
L004	2350015086	INDUCTOR (4.7 μ H)
LP201	2320069004	ANTI BIRDIE FILTER
LP202	2320049008	LOW PASS FILTER
CF001	2610030002	CERAMIC FILTER
CF002	2610047008	FM CERAMIC FILTER
CF003	2610023006	FM CERAMIC FILTER
CF004	2610031001	AM CERAMIC FILTER (BFU450C4)
CF301	2610034008	AM CERAMIC FILTER (SEP450H)
CF302	3990008038	X-TAL (7.2 MHz)
XT401	2169002002	FRONT END
OTHER PARTS		
	2221004304	P.W. BOARD
	EP-5667H1	TERMINAL PIN
	2090008146	JUMPER WIRE P = 5 mm
	2090008120	JUMPER WIRE P = 10 mm
	2050190036	3P NH CONNECTOR BASE
	2060190052	5P NH CONNECTOR BASE
	2050190065	6P NH CONNECTOR BASE
	2050190094	9P NH CONNECTOR BASE
	2050190010	11P NH CONNECTOR BASE
	2050167027	12P NH CONNECTOR BASE
	2050185038	3P WIRE HOLDER
	2050185054	5P WIRE HOLDER
	2034203020	3P CONNECTOR CORD
	2036107012	5P CONNECTOR CORD
	2124458002	SLIDE SW (SCL-202)
	2050236000	3P ANT. TERMINAL
	2050156013	2P CONNECTOR BASE
	4170204017	RADIATOR

Note: D301 and D305 must be replaced at the sometime.

CONNECTION DIAGRAM

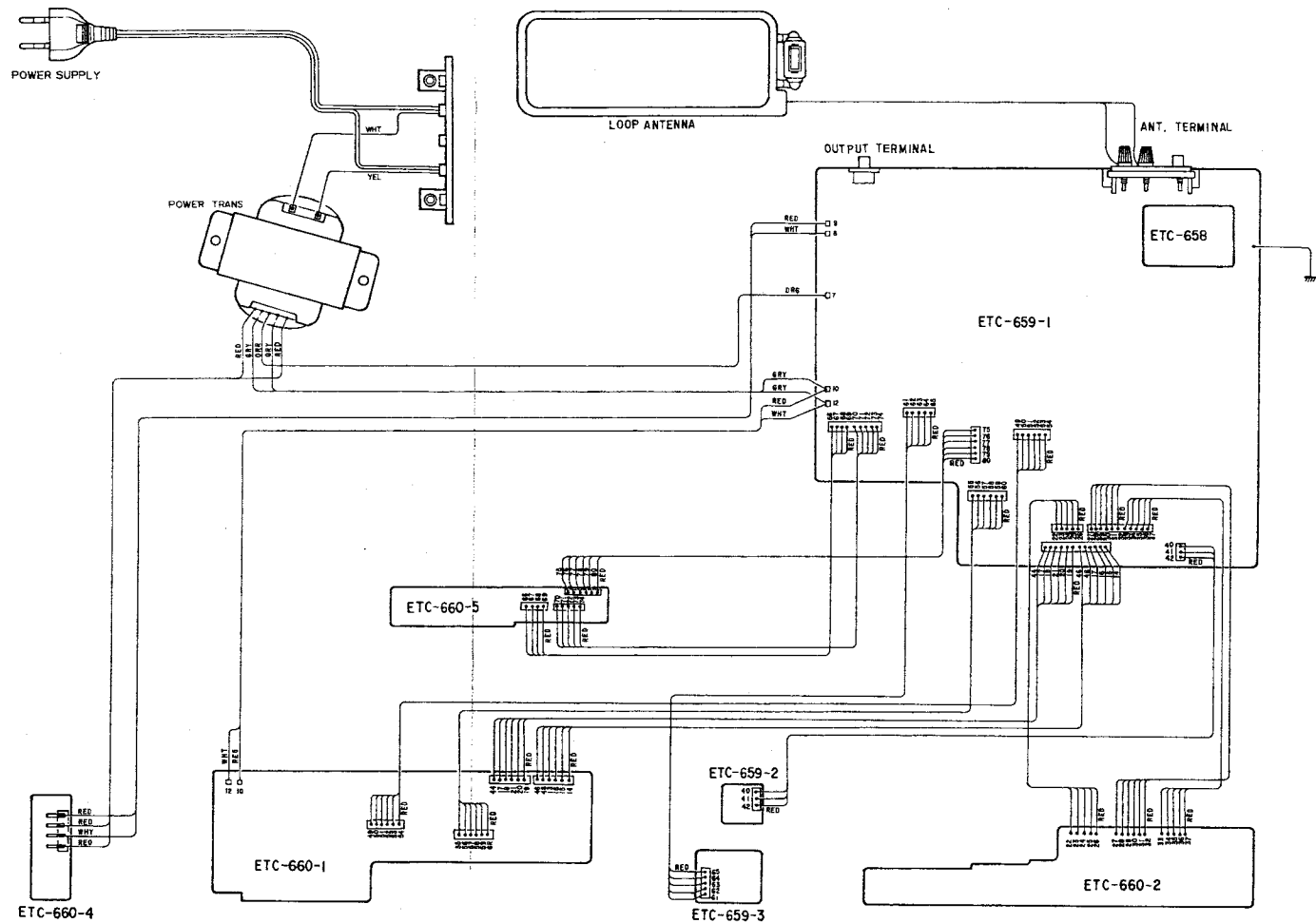

WIRING DIAGRAM

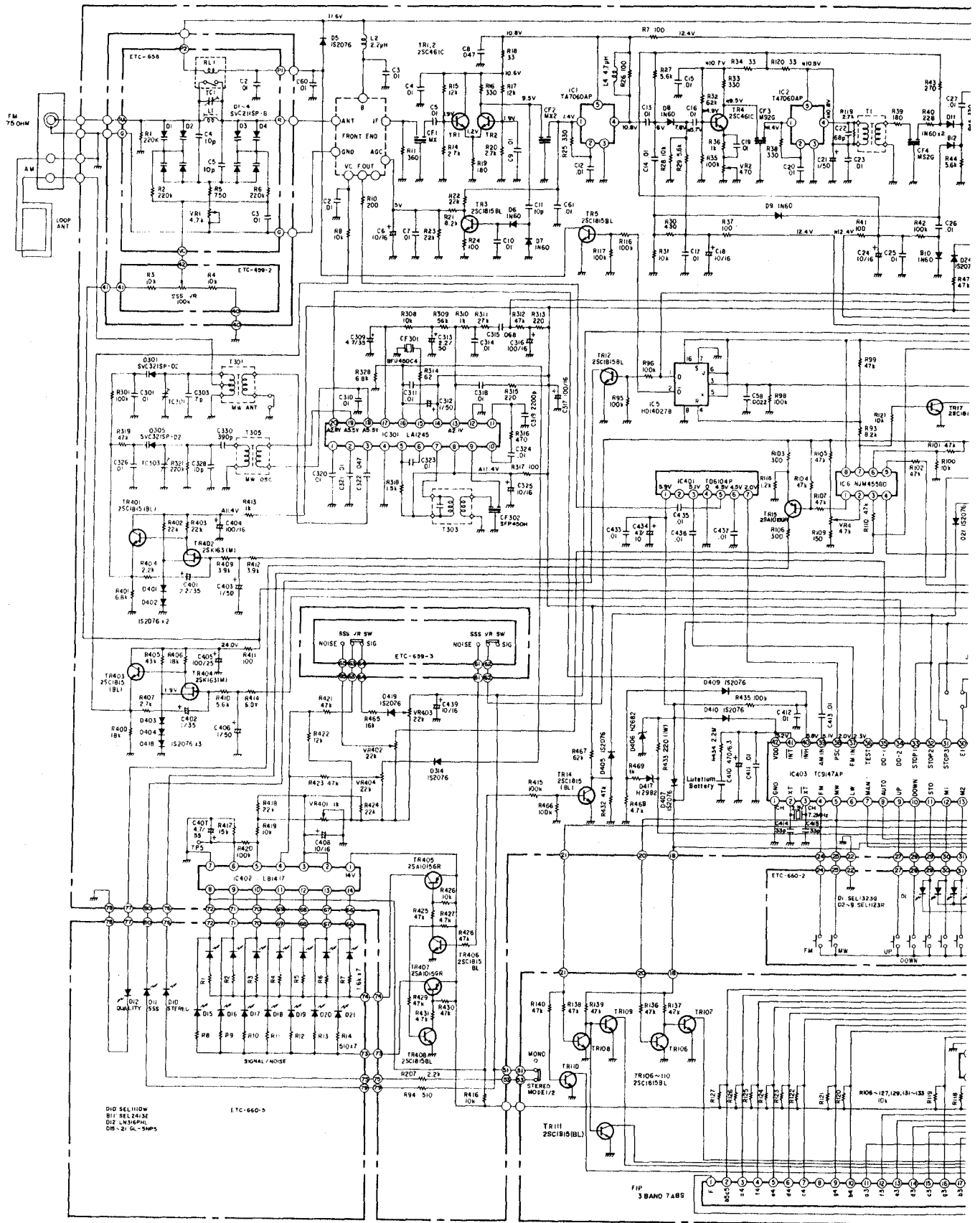

⚠ Means important safety item, which must be replaced, when necessary, by a part specified or meeting the specification by the manufacturer.

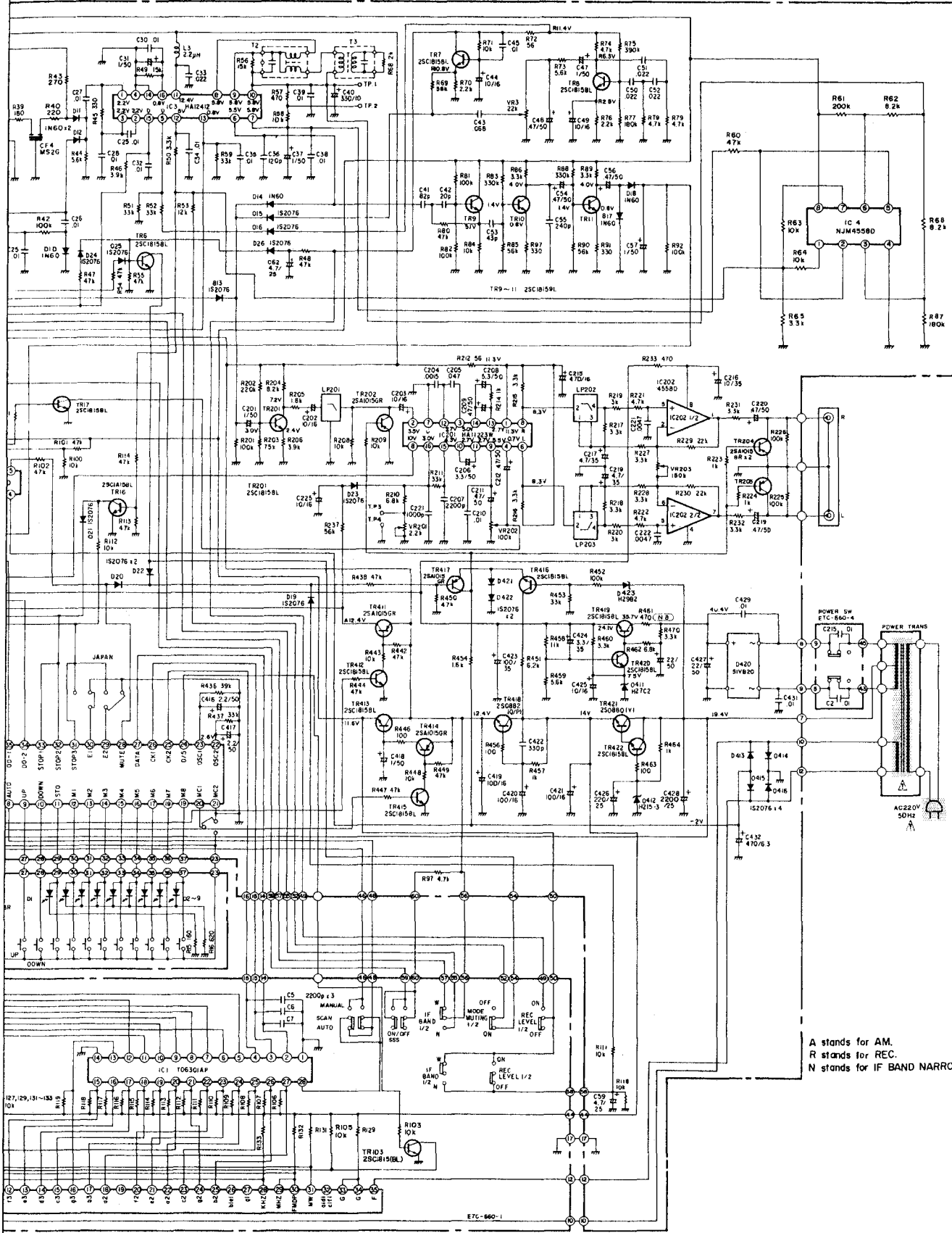

A stands for AM.
R stands for REC.
N stands for IF BAND NARROW.

NOTES
ALL RESISTANCE VALUES IN OHM K = 1,000 OHM M = 1,000,000 OHM
ALL CAPACITANCE VALUES IN MICRO FARAD P = MICRO-MICRO FARAD
EACH VOLTAGE AND CURRENT ARE MEASURED AT NO SIGNAL INPUT CONDITION.
CIRCUIT AND PARTS ARE SUBJECT TO CHANGE WITHOUT PRIOR NOTICE.

EXPLODED VIEW OF CHASSIS AND CABINET

when n
by the n

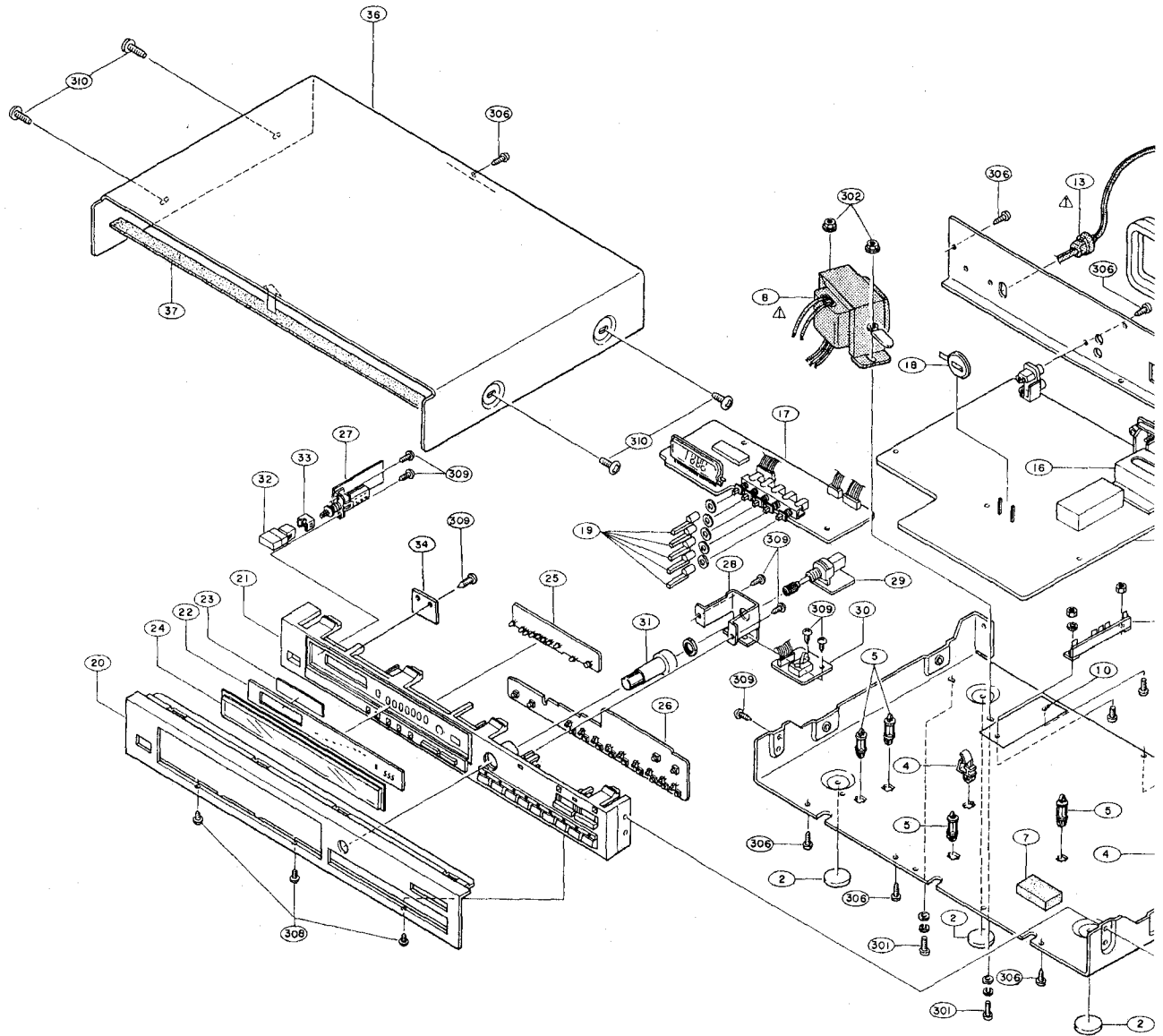

EXPLODED VIEW OF CHASSIS AND CABINET PARTS LIST

Ref. No.	Part No.	Part Name & Descriptions	Q'ty	Ref. No.	Part No.	Part Name & Descriptions	Q'ty	Ref. No.	Part No.	Part Name & Descriptions	Q'ty
1	4110296276	Main Chassis	1	25	ETC0680N-2	Display Unit (LED)	1s	SCREWS & NUT			
2	4610152004	Felt Pad	4	26	ETC0680N-4	Display Unit (SIG)	1s	301	4700010024	Pan Screw 3x8	2
3	4610157080	Cushion	1	27	ETC0680N-6	Display Unit (P/SW)	1	302	SC-10822	Nut-Washer	2
4	MD-4601	PCB Support	1	28	41214B4103	Volume Bracket	1	303	4711304033	Pan Screw 3x8 (Black)	2
5	4430299006	PCB Holder	2	29	ETC0659L-2	Tuner Unit (VR)	1s	304	4766006008	Nut M3	2
6	4430301003	PCB Holder	3	30	ETC0659L-3	Tuner Unit (SW)	1s	305	-	-	-
7	4610178001	Rubber Sheet	1	31	1130503104	Knob Ass'y (Trap)	1	306	4770064107	Fixing Screw	11
8	2050089008	7PW Terminal	1	32	1130501012	Push Knob Ass'y	1	307	4730353010	Tapping Screw (2) 3x6	3
9	2050089008	7PW Terminal	1	33	1140056007	Flexible Ring	1	308	4730303031	Tapping Screw (2) 3x6 (Black)	3
10	415008B004	Insulating Sheet	1	34	ETC0680N-6	Display Unit (FLD)	1s	309	4730304014	Tapping Screw (1) 3x8	7
11	1050617002	Back Panel	1	35	4450033006	Wire Clamp Band	8	310	4734801006	Tapping Screw (Truss) 4x8	4
12	1050617002	Back Panel	1	36	1020122213	Top Cover	1	311	-	-	-
13	1050617002	Back Panel	1	37	1220069008	Spacer	1	312	4770224015	SP Washer	2
14	1460494006	Antenna Holder	1	38	-	-	-	PACKING & ACCESSORIES (not included EXPLDDED VIEW)			
15	ETC0659L-1	Tuner Unit (Main)	1s	39	-	-	-	401	5050075006	Cabinet Cover	1
16	ETC0659L-1	Trap Unit	1s	40	2311060009	Loop Antenna	1	402	5030285007	Cushion	2
17	ETC0680N-1	Display Unit (Main)	1s	41	6130716065	FTZ Label	1	403	5019101021	Carbon Case	1
18	394005007	Lithium Battery	1	42	-	-	-	404	5050061007	Envelope	1
19	1130502118	Push Knob (Function)	5	43	-	-	-	405	5111210108	Inst. Manual	1
20	1441152202	Front Panel	1	44	-	-	-	406	5150271001	Information Card (UH)	1
21	1480638437	Inner Panel Ass'y	1	45	-	-	-	407	2032101001	2P Connector Card	1
22	1430339007	Indicator Sheet	1	46	-	-	-	408	5139111001	Color Label (Gold)	2
23	1430196101	Filter	1	47	-	-	-	409	5138295009	Control Card	1
24	1430337106	Window	1								

Note: * Marked not including EXPLODED VIEW.

Means important safety item, which must be replaced, if necessary, by a part specified or meeting the specification of the manufacturer.

Die Deutsche Bundespost informiert

Sehr geehrter Rundfunkhörer,

Dieses Gerät ist von der Deutschen Bundespost als Ton- bzw. Fernseh-Rundfunkempfänger zugelassen. Es entspricht den zu Teil getretenen technischen Vorschriften der Deutschen Bundespost und ist zum Nachweis dafür mit der PTZ-Prüfnummer 21.382.5 bzw. 21.552.5 (off.) zusätzlich E und/oder D gekennzeichnet. Bitte überzeugen Sie sich selbst. Dieser Gerät darf im Rahmen der nachstehend abgedruckten Allgemeinen Genehmigung für Ton- und Fernseh-Rundfunkempfänger in der Bundesrepublik Deutschland betrieben werden. Beachten Sie aber bitte, daß aufgrund dieser Allgemeinen Genehmigung nur Änderungen des Bauzustandes erfragt werden dürfen, die über auf andere Bauzustände, z. B. des Polarisations, des Betriebs, der öffentlichen beweglichen Bauzustände erfragt, verleiht gegen die Genehmigungsvorgaben und macht sich daher nach § 15 Absatz 2a des Gesetzes über Fernmeldeanlagen strafbar. Die Fernschaltung mit der PTZ-Prüfnummer besitzt ferner die Eigenschaft, daß dieses Gerät keine anderen Fernmeldeanlagen hinsichtlich Funkanlagen stört. Die Zusatzschaltungen S, SE oder SE bei der PTZ-Prüfnummer besagen außerdem, daß das Gerät gegen störende Beeinträchtigungen durch andere Funkanlagen (z. B. der Amateurfunk, des CB-Funks) weitgehend unempfindlich ist. Sollten ausnahmsweise trotzdem Störungen auftreten, so wenden Sie sich bitte an die örtlich zuständige Funkprüfstelle.

Allgemeine Genehmigung für Ton- und Fernseh-Rundfunkempfänger

Die Allgemeine Ton- und Fernseh-Rundfunkgenehmigung vom 11.12.1970 wiederum ist in Bundesgesetz Nr. 234 vom 16.12.1970 und unter Bezug auf Abschnitt II der Genehmigung durch folgende Fassung der Allgemeinen Genehmigung für Ton- und Fernseh-Rundfunkempfänger gemäß den §§ 1 und 2 des Gesetzes über Fernmeldeanlagen ersetzt.

Genehmigung für Ton- und Fernseh-Rundfunkempfänger

- Die Erprobung und der Betrieb von Ton- und Fernseh-Rundfunkempfängern werden nach §§ 1 und 2 des Gesetzes über Fernmeldeanlagen in der Fassung der Bekanntmachung vom 13.12.1970 (BGBl. I, S. 459) allgemein genehmigt.
- Ton- und Fernseh-Rundfunkempfänger im Sinne dieser Genehmigung sind Funkanlagen gemäß § 1 Absatz 1 des Gesetzes über Fernmeldeanlagen, die ausschließlich die für Rundfunkempfang zugelassenen Frequenzbereiche (nicht) aufweisen und zum Aufnehmen und gleichzeitigen Hör- oder Sichtschauen von Ton- oder Fernseh-Rundfunkausstrahlungen bestimmt sind zum Empfänger gehören auch Eingabegeräte oder mit ihm fest verbundene Anlagen sowie die Lieferung in mehrere Geräte die Funkstrahlung zuhörenden Geräte. In den Empfänger einbaufähig oder sonst mit ihm verbundene Zusatzgeräte (z. B. Ultraschallfernsehröhren, Mikrofonverstärker) werden von dieser Genehmigung nicht erfaßt. Ausgenommen die Einrichtungen zum Empfang des Fernsehstrahlungsdienstes sind andere technische Empfangseigenschaften, die über den üblichen Zweck eines Rundfunkempfängers hinausgehen (z. B. zum Empfang anderer Funkdienste, für die Weitergabe im Rahmen von Textübertragungsdiensten hierdurch nicht genehmigt). Hierfür gelten besondere Bestimmungen.

Diese Genehmigung wird unter nachstehenden Auflagen erteilt:

- Ton- und Fernseh-Rundfunkempfänger müssen den jeweils geltenden technischen Vorschriften für Ton- und Fernseh-Rundfunkempfänger entsprechen. Eingebaute Zusatzgeräte müssen für sie geltenden technischen und technischen Vorschriften genügen. Änderungen der technischen Vorschriften, die im Anhang des Bundesgesetzes für die Post- und Fernmeldeanlagen veröffentlicht werden, muß bei schon erprobten und in Betrieb genommenen Ton- und Fernseh-Rundfunkempfängern nachgekommen werden, wenn durch den Betrieb dieser Rundfunkempfänger andere elektrische Anlagen gestört werden. Serienmäßig hergestellte Ton- und Fernseh-Rundfunkempfänger müssen zum Nachweis dafür, daß sie den technischen Vorschriften entsprechen, mit einer PTZ-Prüfnummer gekennzeichnet sein. Die PTZ-Prüfnummer sagt über die elektrische und mechanische Sicherheit und die Einhaltung der Strahlenschutzbestimmungen nichts aus.

- Zum Empfang anderer Sendungen darf dieses Gerät nur mit Genehmigung der Deutschen Bundespost benutzt werden. Allgemein genehmigt ist zur Zeit der Empfang der Ausstrahlungen von Amateurfunkstellen und Zeitzeitsendungen.
- Siehe technische Vorschriften für Ton- und Fernseh-Rundfunkempfänger, veröffentlicht im Anhang des Bundesgesetzes für die Post- und Fernmeldeanlagen.
- Für Ausnahmefälle nach nicht geltend, vor dem 1.7.1979 erprobte und in Betrieb genommene Ton-Rundfunkempfänger wird die Kennzeichnung nicht verlangt.

- Ton- und Fernseh-Rundfunkempfänger dürfen an ortsfesten oder nicht ortsfesten Rundfunk-Empfangsantennenanlagen, Verteilungsanlagen oder Leuchtelementen angeschlossen werden und im Rahmen der Bestimmungen über solche Drahtfernmeldeanlagen mit Drahtfernmeldeanlagen verbunden werden. Auf ferngesteuerten Grundböden oder außerhalb eines Härtunges dürfen Ton- und Fernseh-Rundfunkempfänger mit anderen Geräten oder sonstigen Gegenständen (z. B. Plattenspieler, Magnetlaufwerke und -Wiederabgabegeräte, Antennen) verbunden werden, sofern diese Geräte von der Deutschen Bundespost genehmigt sind oder keiner Genehmigung bedürfen. Die räumliche Kombination von Funkanlagen mit Ton- oder Fernseh-Rundfunkempfängern ist nur dann zulässig, wenn die betreffenden Funkanlagen für sich genehmigt sind.

- Mit Ton- oder Fernseh-Rundfunkempfängern dürfen aufgrund dieser Genehmigung nur Sendungen des Rundfunks empfangen werden, also übertragene Tonsignale (Musik, Sprache) und Fernsehbilder (nur Bildinformationen). Andere Sendungen (z. B. des Polizeifunks, der öffentlichen beweglichen Landfunkdienste, Datenübertragung) dürfen nicht aufgenommen werden, werden sie jedoch unabsichtlich empfangen, so dürfen sie weder aufzeichnet, noch anderen zugänglich, noch für irgendwelche Zwecke ausgewertet werden. Das vorhandene sichere Sendungen darf auch nicht anderen zur Kenntnis gebracht werden.

- Durch Ton- oder Fernseh-Rundfunkempfänger darf die Betrieb anderer elektrischer Anlagen nicht gestört werden.
- Änderungen der Ton- oder Fernseh-Rundfunkempfänger, die die zulässigen Frequenzbereiche der Empfangsgeräten betreffen, gehen über den Umfang dieser Genehmigung hinaus und bedürfen vor ihrer Ausführung einer besonderen Genehmigung der Deutschen Bundespost. Wie aufgrund dieser Genehmigung einen Ton- oder Fernseh-Rundfunkempfänger betreibt, hat bei einer Änderung der entsprechenden Merkmale von Ton- oder Fernseh-Rundfunkempfänger insbesondere bei Änderung der Senderfrequenz oder bei Frequenzwechsel die ggf. notwendige veränderte Änderungen an den Rundfunkempfängern auf seine Kosten vornehmen zu lassen.

- Die Deutsche Bundespost ist berechtigt, Rundfunkempfänger und mit ihnen verbundene Geräte darauf zu prüfen, ob sie den Auflagen der Genehmigung und der technischen Vorschriften entsprechen. Die Prüfungen werden im Rahmen der Deutschen Bundespost im Dienst der Grundstücke oder Räume, in denen sich Ton- oder Fernseh-Rundfunkempfänger befinden, zu dem unmittelbaren Ziel zu gestalten. Betrieben sich die Rundfunkempfänger oder mit ihnen verbundene Geräte nicht im Verfügungsbereich des Empfängers, der die Empfänger betreibt, so hat er den Beauftragten der Deutschen Bundespost Zutritt zu diesen Teilen zu ermöglichen.

Bei Funktionsstörungen die nicht durch Mängel der Rundfunkanlage oder der mit ihnen verbundenen Geräte verursacht werden können die Funkdienste der Deutschen Bundespost zur Feststellung der Störung in Anspruch genommen werden.

- Diese Genehmigung kann allgemein oder durch die örtlich zuständige Oberpostdirektion einem einzelnen Betreiber gegenüber für einen bestimmten Rundfunkempfänger erteilt werden. Ein Widerruf ist insbesondere zulässig, wenn die unter Abschnitt II aufgeführten Auflagen nicht erfüllt werden. Anstatt die Genehmigung zu widerrufen, kann die Deutsche Bundespost anordnen, daß bei einem Verstoß gegen eine Auflage ein Ton- oder Fernseh-Rundfunkempfänger außer Betrieb zu setzen ist und erst bei Einhaltung der Auflagen wieder betrieben werden darf. Die Auflagen dieser Genehmigung können jeweils ergänzt oder geändert werden.

- Diese Genehmigung ersetzt die Allgemeine Ton- und Fernseh-Rundfunkgenehmigung vom 11.12.1970, sie gilt ab 1.7.1979.

Bonn, den 14.5.1979

Der Bundesminister
für die Post- und Fernmeldewesen
in Auftrag

NIPPON COLUMBIA CO., LTD.

No. 14-14, 4-CHOME AKASAKA,
MINATO-KU, TOKYO 107, JAPAN
TEL: 03-584-8111
TLX: JAPANOLA J22591
CABLE: NIPPONCOLUMBIA TOKYO

