

Service Manual

Dual 1008 / A

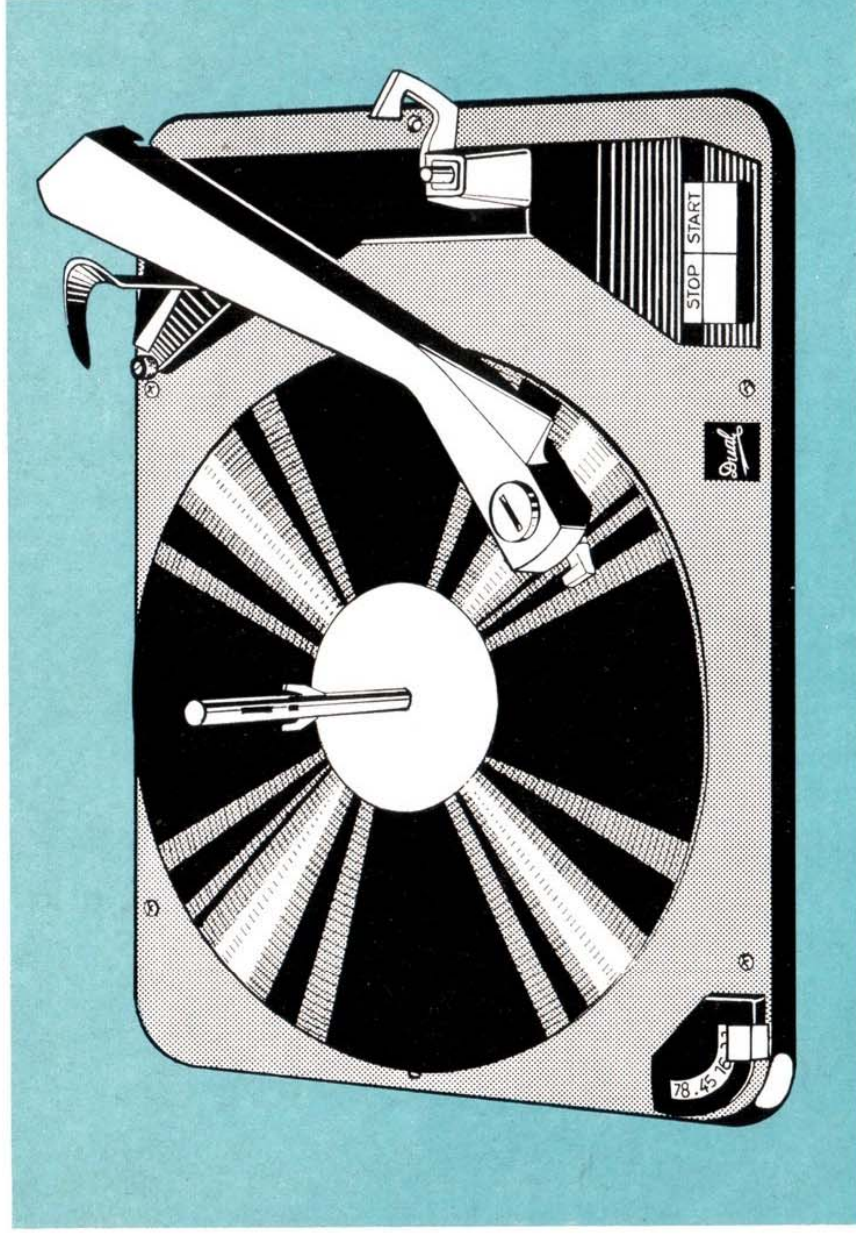

Edition 181121

General Information

The stereo record changer Dual 1008 / A is designed for playing of 78 rpm-, LP and stereo records and can be used either as automatic record changer, automatic or manual single player. The unit is designed for turntable speeds of $16\frac{2}{3}$, $33\frac{1}{3}$, 45 and 78 rpm and plays 7", 10" and 12" records fully automatically.

The tone arm (with plug-in head) is equipped with the stereo crystal cartridge Dual CDS-620 (turnover cartridge) and can also be equipped with other conventional crystal- and ceramic pick-up cartridges.

As a standard, the cartridge CDS-620 comes equipped with the sapphire needle DN-4 (for stereo and LP records), and DN-45 (for 78 rpm records). As a replacement, special needles of different tip diameters are available either as sapphires or diamonds.

The Dual 1008 / A is operated by push-buttons (Start and Stop) whereby the START button also serves as a REJECT control (instant changing). Pressing of STOP button interrupts the play immediately, with the tone arm being returned to its rest position and the unit automatically shuts off. Automatic shut-off and return of tone arm to rest position also follows completion of a single record or of the last record in a stack.

The motor is designed for alternating current of 110 / 150 / 220 volts and is adjustable to power-line frequencies of 40, 50 or 60 cycles per second.

An extra-heavy high-fidelity turntable (Type 13 / 1008 A) is optional, and for automatic play of up to ten 45 rpm records a large centre hole dropping spindle AS-6 is available.

G E B R Ü D E R S T E I D I N G E R · S T . G E O R G E N / B L A C K F O R E S T

3. Functions of the Individual Components

Motor:

Turntable and gears are driven by a powerful 2-pole asynchronous motor (117) with a two dimensionally balanced rotor, super-finished bearings and vibration-free operation.

The speed of the motor is constant within a fluctuation of $\pm 10\%$ of the power line voltage. Speed deviations occur in direct proportion to the power line frequency.

The motor can be adapted to line frequencies of 40, 50 or 60 c/s by installation of the following motor pulleys (see fig. 1—130):

Pulley for 40 c/s: Order No. 31 B - 69

Pulley for 50 c/s: Order No. 31 B - 50

Pulley for 60 c/s: Order No. 31 B - 63

For removal and installation of motor pulleys a special tool (Pulley Extractor KDW-101) is available. When exchanging drive pulleys, it is essential that the motor shaft does not become bent, otherwise rumble might occur.

The field coil is mounted before final assembly of the stator. It is therefore necessary to always replace the complete stator (118) in case of a defective field coil.

Fig. 1

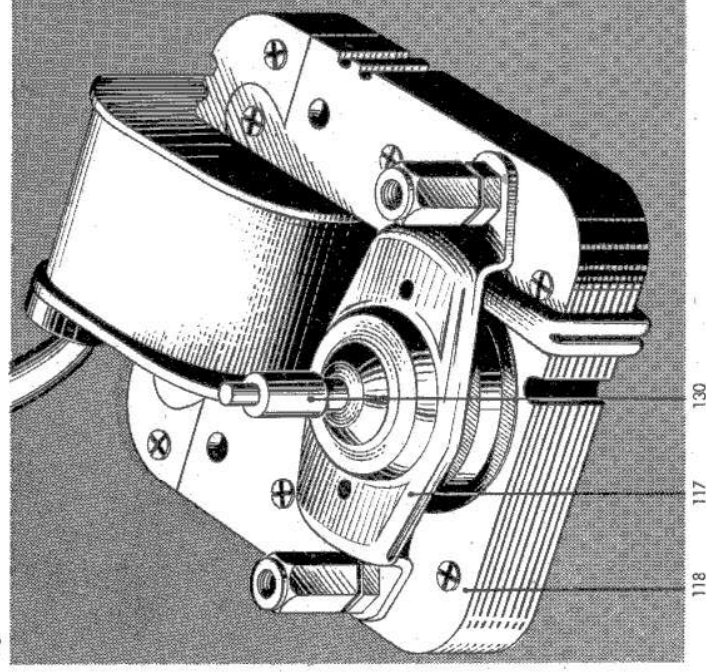
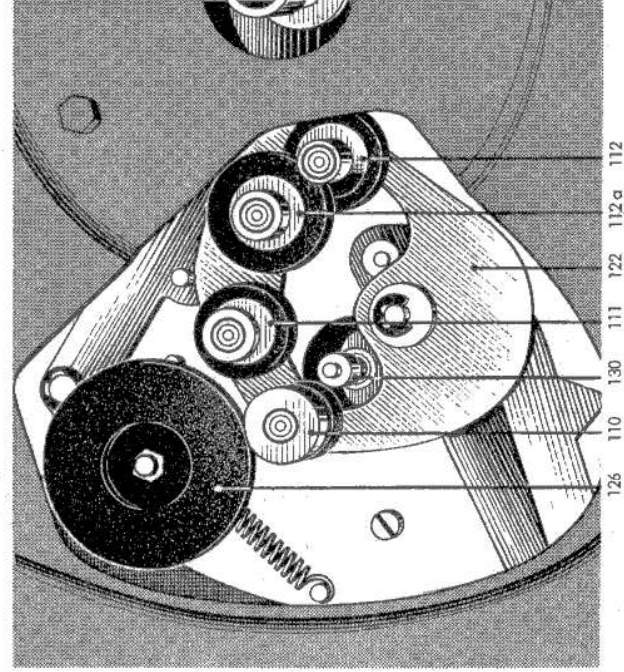

Fig. 2



Drive for Turntable and Changer Mechanism:

The different turntable speeds of $16\frac{2}{3}$, $33\frac{1}{3}$, 45 and 78 rpm are obtained by the different settings of the friction drive wheel assembly, reducing the motor speed.

The turntable is driven by the drive wheels (110—112a) and the idler wheel (126). For perfect balance the drive wheels have been individually ground concentrically to their bearings.

When the surface of a drive wheel appears to be worn, the entire wheel must be replaced since replacement of the rubber rings alone might increase the rumble level.

For additional shipping protection of the unit, a transit position is marked on the speed selector switch and in this position all drive wheels (110—112a) are completely disengaged.

Fig. 3

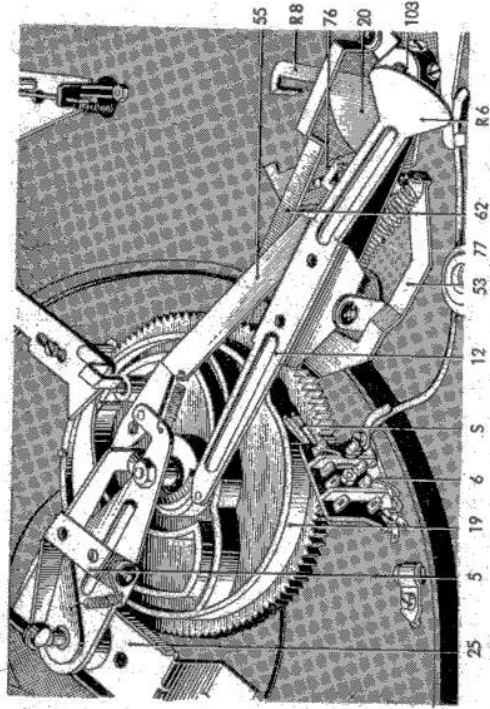

Control of Tone Arm Movements:

The movements of the tone arm for the automatic set-down and lifting are controlled by the cams on the lower side of the cam wheel (19) during its 360° cycle. The controlling elements for the lifting and lowering of the tone arm are the main lever (12) and the lifting stud (103). The lateral movement of the tone arm is controlled by the main lever with segment (20).

The set-down points of the tone arm on the record are governed by the three steps of the post (76) which correspond with the record diameters of 7, 10 and 12".

The lateral movement of the tone arm is limited by touching of the lever (R 8) of the segment (20) against the above-mentioned steps of the post.

Fig. 4

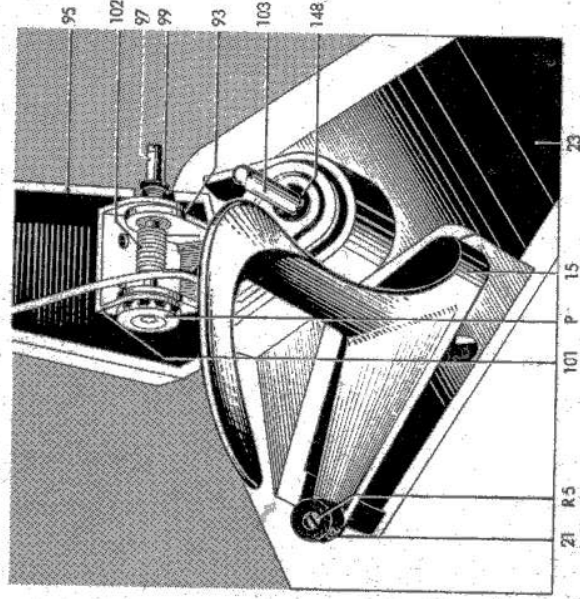

**Tone Arm Suspension —
Tone Arm Tracking Weight:**

The vertical suspension of the tone arm is shown in the illustration at the left. The tracking weight of the tone arm can be adjusted by turning of the shaft (97) which tightens or loosens the spring (102). The desired adjustment of the shaft (102) is secured by the lock (P) inside the notched bearing bracket.

Fig. 5

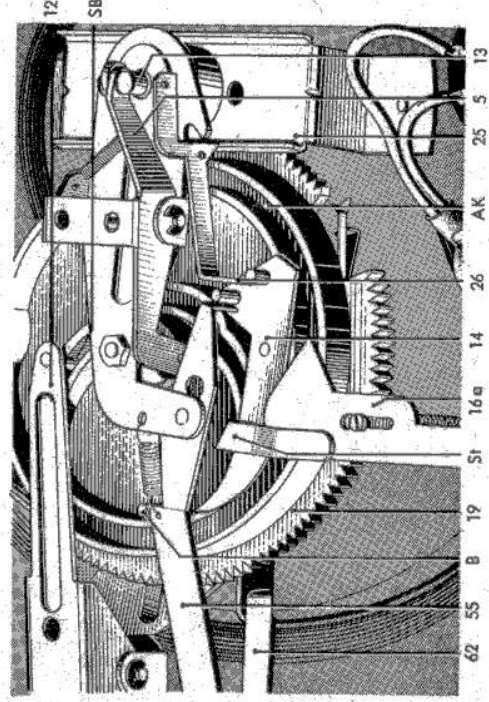

Record Drop:

Two spindles are available for stacking of records, the automatic changing spindle AW 2 for standard records with small center holes and the special dropping spindle AS-6 for 7" records with large center holes. The dropping process is initiated by the rotation of the cam wheel (19) which controls the dropping lever (5) and the changing bolt (13).

The resulting movement of the changing bolt (13) actuates the dropping of a record from the changing spindle.

The cam on the cam wheel (19) is so designed that a record can only be dropped while the tone arm is over its rest position and thus outside the diameter of the largest possible record (12").

Muting Switch:

To eliminate noise during the changing cycle and during the automatic lowering and lifting of the tone arm, a muting switch (6, Fig. 3) is provided. The contact springs (5, Fig. 3) for the pick-up leads of both channels are actuated by the cam wheel (19, Fig. 3). In the rest position of the tone arm, the tone arm leads are not shorted.

Fig. 6

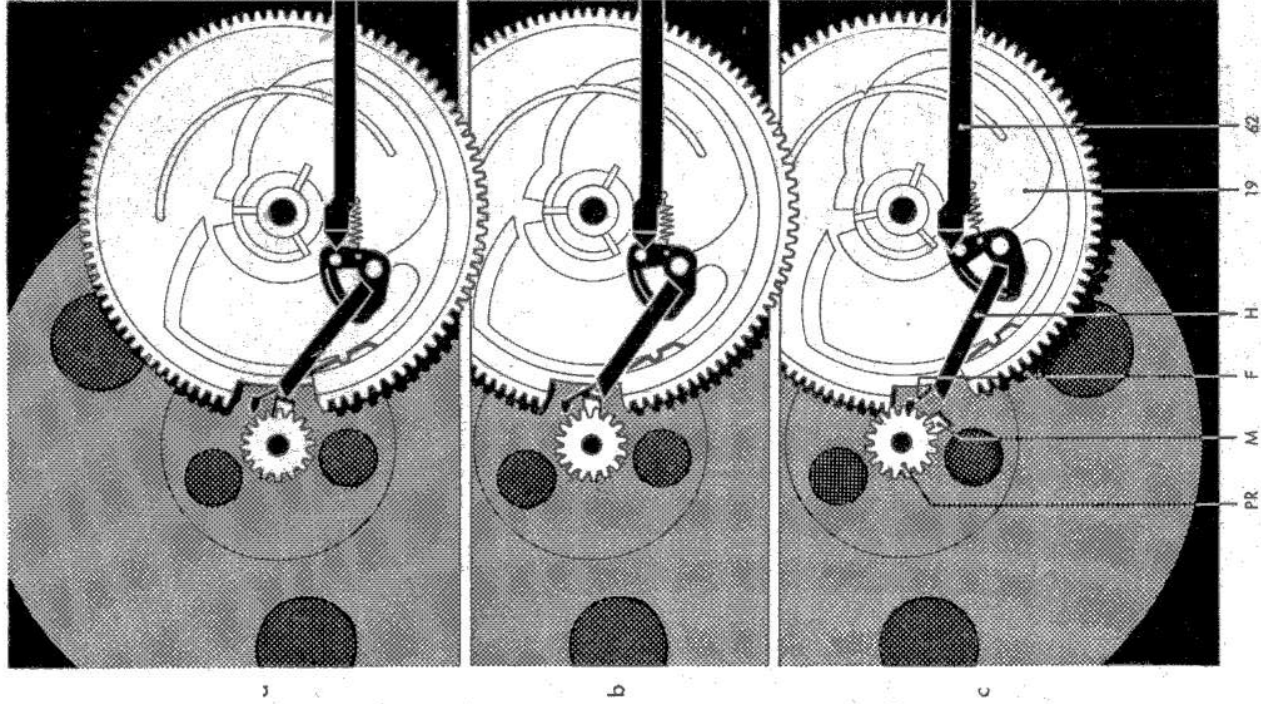

Shut-Off and Changing Cycle:

The introduction of the changing cycle after playback of a record and the final shut-off after playback of the last record in the stack is accomplished by the follower (M) of the turntable pinion (PR) and the shut-off lever (H).

With the lateral movement of the tone arm during playback the shut-off lever (H) will be moved with the aid of the shut-off bar (62) towards the follower (M). This movement is proportional to the groove pitch. The eccentricity-mounted follower pushes the shut-off lever back with each revolution as long as the advance of the tone arm is only one groove width (Fig. 6 a).

Only the run-out groove with its greater pitch leads the shut-off lever (H) with greater velocity towards the follower (M) so that the shut-off lever will be latched on to and will be taken along (Fig. 6 b).

The cam wheel (19) is thereby brought out of its neutral position through the dropping spring (F) and into engagement with the pinion (PR) of the turntable (Fig. 6 c).

Final Shut-Off:

The functions of the shut-off and changing cycle are governed by the position of the control lever (14, Fig. 5). Upon dropping of the last record, the control lever is actuated by the switch lever (26, Fig. 5). To introduce the final shut-off the control lever (14, Fig. 5) is pushed by the switch lever (26, Fig. 5) into such position (longer end pointing towards centre of cam wheel) that the steering bolt (SB, Fig. 5) of the main lever (12, Fig. 5) reaches the outer cam (AK, Fig. 5) of the cam wheel (19, Fig. 5) upon outward movement of the tone arm over its rest position. The vertical cam contour causes the tone arm to set down on its rest, thereby shutting off the unit.

Fig. 7

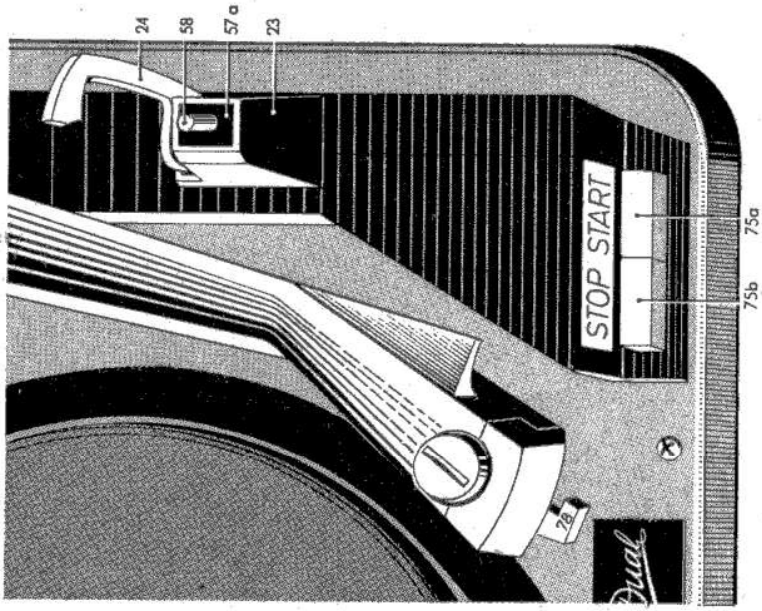

Start:

Pressing of the switch key (75 a, Fig. 7, 8) releases the start lever (16 a, Fig. 8) which is pulled by its tension spring towards the cam wheel (19, Fig. 5). This causes the starting bolt (B, Fig. 9) of the cam wheel to slide off from the inclination of the start lever (16 a, Fig. 8) thereby engaging the cam wheel with the gear. At the same time, the start lever (16 a, Fig. 8) actuates the power switch (spring switch Pos. 18, Fig. 8) through switch bracket (61, Fig. 8).

With the starting of the motor, the friction wheels drive the turntable which in turn drives the cam wheel. This 360° rotation of the cam wheel actuates dropping of a record, indexing of record size and setting down of tone arm on the record.

Fig. 8

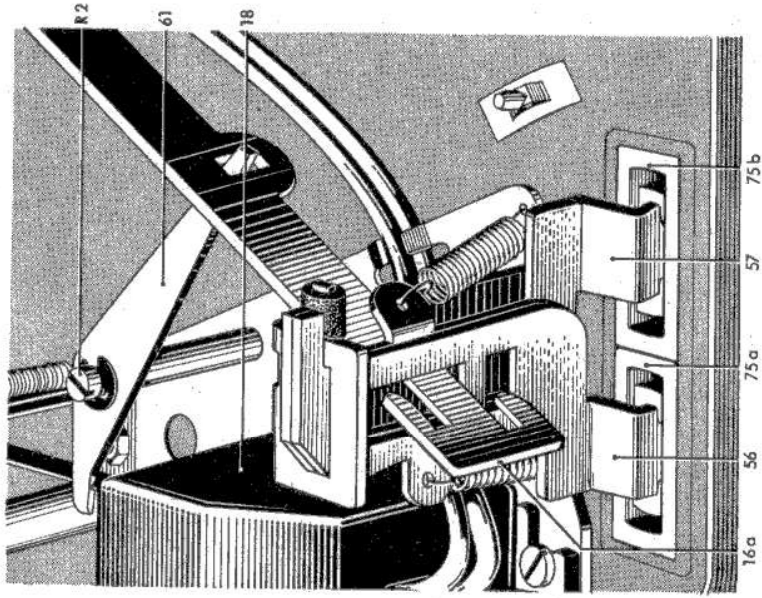

Stop:

By depressing the stop button (75 b, Fig. 7, 8), just as with the start button with its start lever (16 a), the cam wheel becomes engaged with the turntable pinion and thereby initiates a changing cycle.

Due to the larger throw of the stop key, and the stop pusher bar (57) the start lever (16 a) will at the same time be tilted so far downwards that the rotation cam wheel causes the switch lever (ST, Fig. 5) of the start lever to engage with the shift lever (14, Fig. 5), thereby initiating the final shut-off.

Automatic Indexing of Record Diameter:

For automatic indexing of 7", 10" and 12" records the feeler arm (15, Fig. 10) is employed. The feeler arm is deflected according to the record diameter while using the unit as an automatic record changer. When operated as an automatic single player, the pick-up dropping point on the record is determined by the roller (21, Fig. 10) of the feeler arm.

Control of the feeler arm (15, Fig. 10) for indexing of 7", 10" and 12" records is effected by the cam wheel.

The rotating cam wheel releases the setting lever (53, Fig. 9) before dropping of a record. This lever will be pulled towards the centre of the cam wheel by the tension spring (77, Fig. 3). The link (27, Fig. 9) located below the mounting plate is coupled with the setting lever (53, Fig. 9) and transmits the centripetal motion of the setting lever to the dog (76, Fig. 9) which is engaged with the feeler arm (15, Fig. 10) and which in turn guides it in the direction of the turntable.

Immediately upon completion of the inward motion of the feeler arm, the record drop occurs. Dropping of a 10" or 12" record deflects the feeler arm in proportion to record diameters. Through the feeler arm, the dog (76, Fig. 9) will be moved in the same outward direction causing the step of the dog, which corresponds to the record size, to line up with the nose (R 8, Fig. 9) of the segment.

When used as an automatic record changer, the indexing of record size is achieved by the roller (21, Fig. 10) of the feeler arm, which during its inward motion briefly touches the outer edge of 10" and 12" records.

The necessary lifting of the feeler arm is achieved by the lift rail (55, Fig. 9) which is actuated by the shift lever (14, Fig. 5) only during single play.

Fig. 10a, 10b = operation as automatic record changer
Fig. 10c = operation as automatic single player

Fig. 9

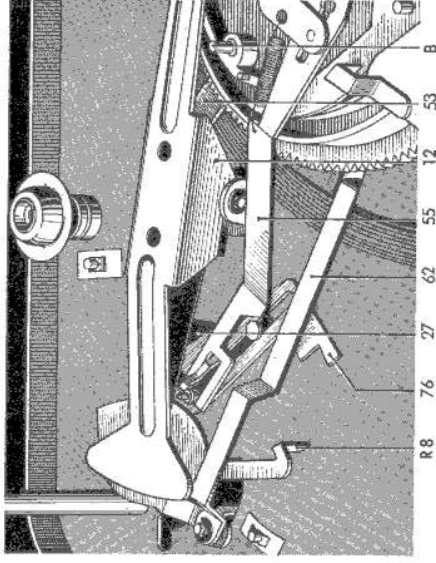
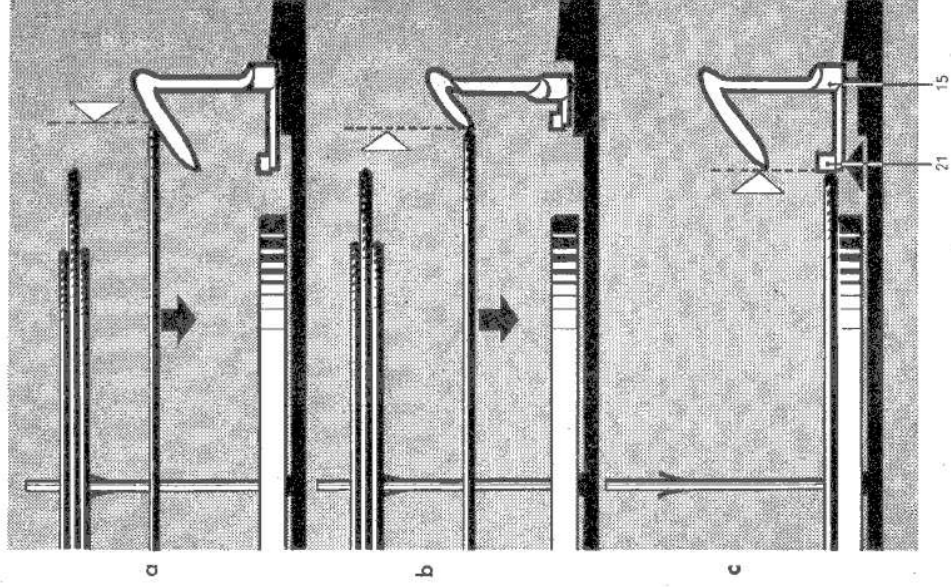

Fig. 10



Adjustments:

Tone Arm Tracking Weight:

Adjust screw R 4 to approx. 5—6 p.

Increasing of tracking weight:

Turn adjustment screw clockwise.

Reducing of Tracking weight:

Turn adjustment screw counter-clockwise.

Turning the adjustment screw by one notch results in a change of tracking pressure by approx. 0.5 p.

Tone Arm Height Adjustment:

Bend lip (R 6) of the main lever (12) while the cam wheel (19) is in neutral position.

Adjustment is correct when the tone arm runs approx. 3—4 mm above the top edge of the plunger and when the lip (R 6) rests parallel to the upper segment surface.

Set-Down Point of Tone Arm: (on record)

Bend the right-angle lip (R 8) of the segment (20).

Adjustment is correct when the pick-up sets down on the record approx. 2—3 mm from outer record edge.

Tone Arm Position Over Rest:

Rotate segment (20) upon loosening of the two screws (R 9).

Adjustment is correct when the plunger (58) recedes freely into the cut-out of the tone arm when lowering.

Tone Arm Clutch: (Brake)

While the cam wheel (19) is in neutral position bend the leaf spring (of main lever 12) so that required transport- and brake-action is obtained.

Adjustment is correct when in the neutral position of the cam wheel (19) the distance between the drive pimple of the leaf spring and the brake surface of the segment (20) is approx. 0.5 mm. (The friction surface of the segment (20) must under all circumstances be kept free from grease).

Start Lever Adjustment:

Bend the lip (R 10) on the switch plate (16).

Adjustment is correct when the start peg (on cam wheel) displaces the start lever (16a) by approximately 0.5 mm while the cam wheel is rotating.

Actuation of Power Switch:

(only when used as

record changer)

Adjust eccentric screw (R 2).
Adjustment is correct when, on depressing of the start key, the switch link (61) rests in the slot of the start lever (16a) without play or pressure.

Lift of Changer Rod: (for record drop)

Adjust with eccentric screw (R 1).

Adjustment is correct when the three supports (fingers) of the changing spindle are fully retracted and an additional lift of approx. 0.3 mm is observed upon further rotation of the cam wheel.

Trigger Point of Shut-Off:

Adjust eccentric screw (R 3).

Adjustment is correct when the equipment shuts off in the record diameter range of 122—128 mm.

(For checking this adjustment, a special test record, such as made by the Deutsche Grammophon Gesellschaft, No. 329013, is recommended).

Final Shut-Off:

Bend the switchover lever (26) at point R 7.

Adjustment is correct when the switchover lever (26) with locked and record-loaded spindle, passes the drive pin of the shift lever (14) at a distance of approx. 0.5 mm (changing cycle). Without records on the changing spindle, the switchover lever should engage with the pin of the shift lever by approx. 1 mm (final shut-off).

Stopping:

Bend the control bracket (R 11) of the start lever (16a).

Adjustment is correct when, with stop key depressed and rotating of cam-wheel (19), the control bracket (R 11) engages with the outer pin of the shift lever by approx. 0.5 mm.

Position of the Roller: (on the feeler arm)

Turn adjusting screw (R 5).

Adjustment is correct when, on playing of a 10" record, the distance between the record and the top edge of the roller (21) is approx. 0.5 mm.

Fig. 11 (seen from above, turntable removed)

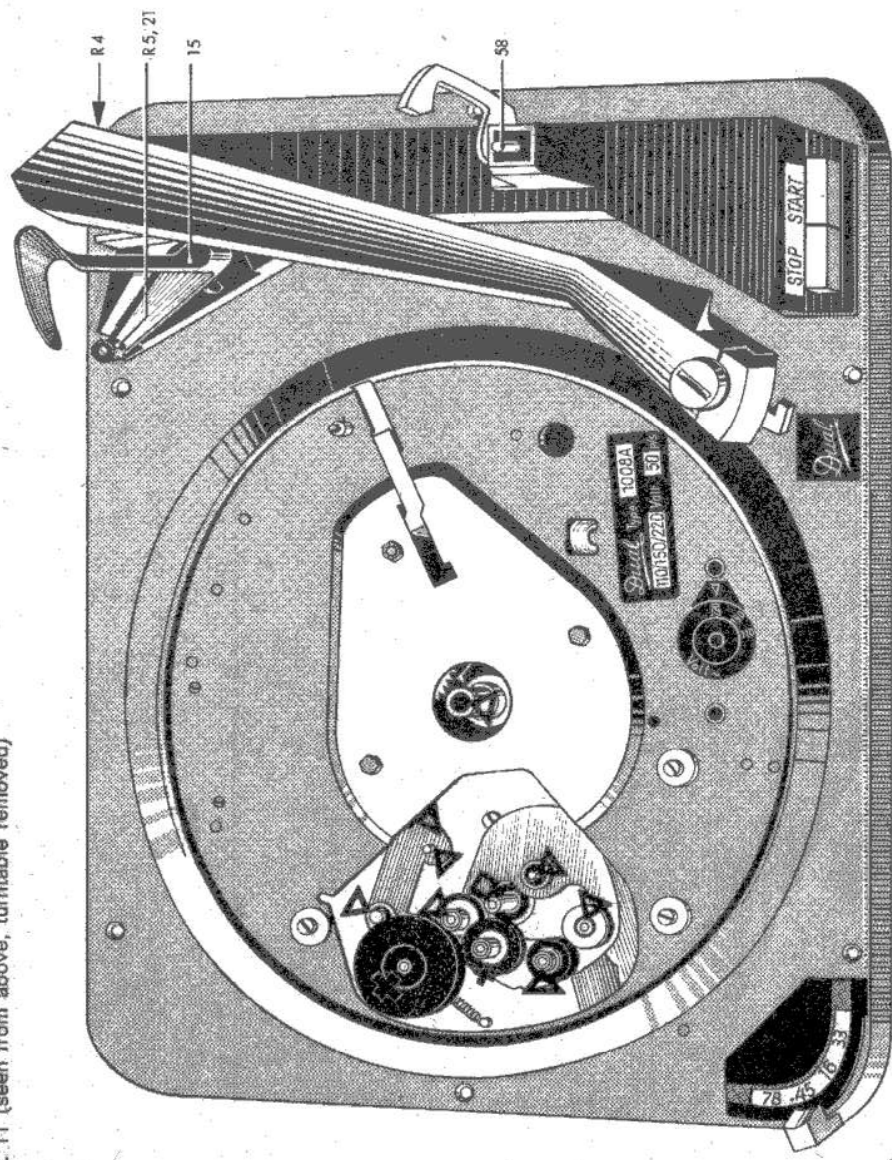
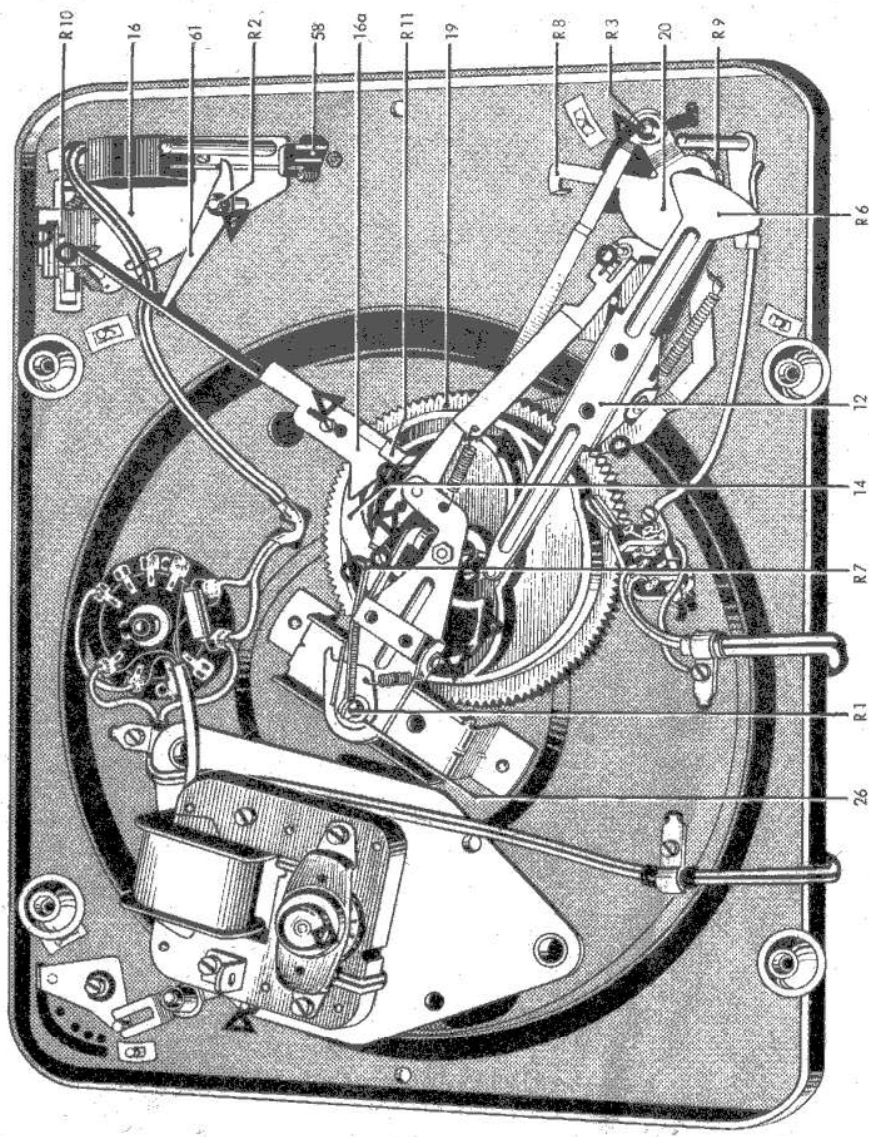

Fig. 12 (from below)



5. Lubrication Instructions (Refer to illustrations on Page 9)

All bearings and sliding surfaces of the record changer have been adequately lubricated at the factory. The most important bearings (motor and drive wheel assembly) are equipped with oil-lite bearings and re-lubrication of the changer should under normal use become necessary only after 1—2 years.

Bearings and sliding surfaces should be lubricated sparingly rather than generously. It is important that no lubricants reach the friction surfaces of the drive wheels (under the turntable) or the idler wheel (130) otherwise slippage will occur.

For re-lubrication the following lubricants should be used:

- Fine bearing oil (Shell - AB 11) for the oil-lite bearings and the motor bearings.
- Thicker non-gumming oil (Calypsol WIK 700) for sliding surfaces, bearings and the oil-lite bearings of the drive wheel assembly.
- Renotac 342 for the turntable bearing, the bearings of the idler wheel and of the 16 rpm speed wheel.
- Molykote Paste G for points of greater pressure and friction.

Mixing of different lubricants very often leads to chemical disintegration and should therefore be avoided. Only the above recommended lubricants should be used.

6. Installation Instructions

The chassis of the record changer should be mounted in accordance with the dimensions shown on the template (Fig. 13). The size of the mounting board should at least be 385 x 315 mm (15¼ x 12½") and at least 16—18 mm (.63—.7"). Frame construction is the most practical.

In order to keep the chassis free from vibration and to avoid acoustic feed-back, four spring suspensions are provided. When mounting the changer on a board, the four spring cups enter the corresponding holes on the board and these are fastened with screws from below.

In order to avoid damage during transit, a set of screws is provided for bolting the chassis to the board. When inserting the wood anchor nuts into the lower side of the board at the holes indicated with (a), these should be straightened out by inserting the screw bolts through the holes in the board.

It should also be observed that no moving parts of the chassis can touch either a wall of the enclosing cabinet or part of the mounting board. Care should be taken to remove wood splints.

Fig. 13, Mounting Template

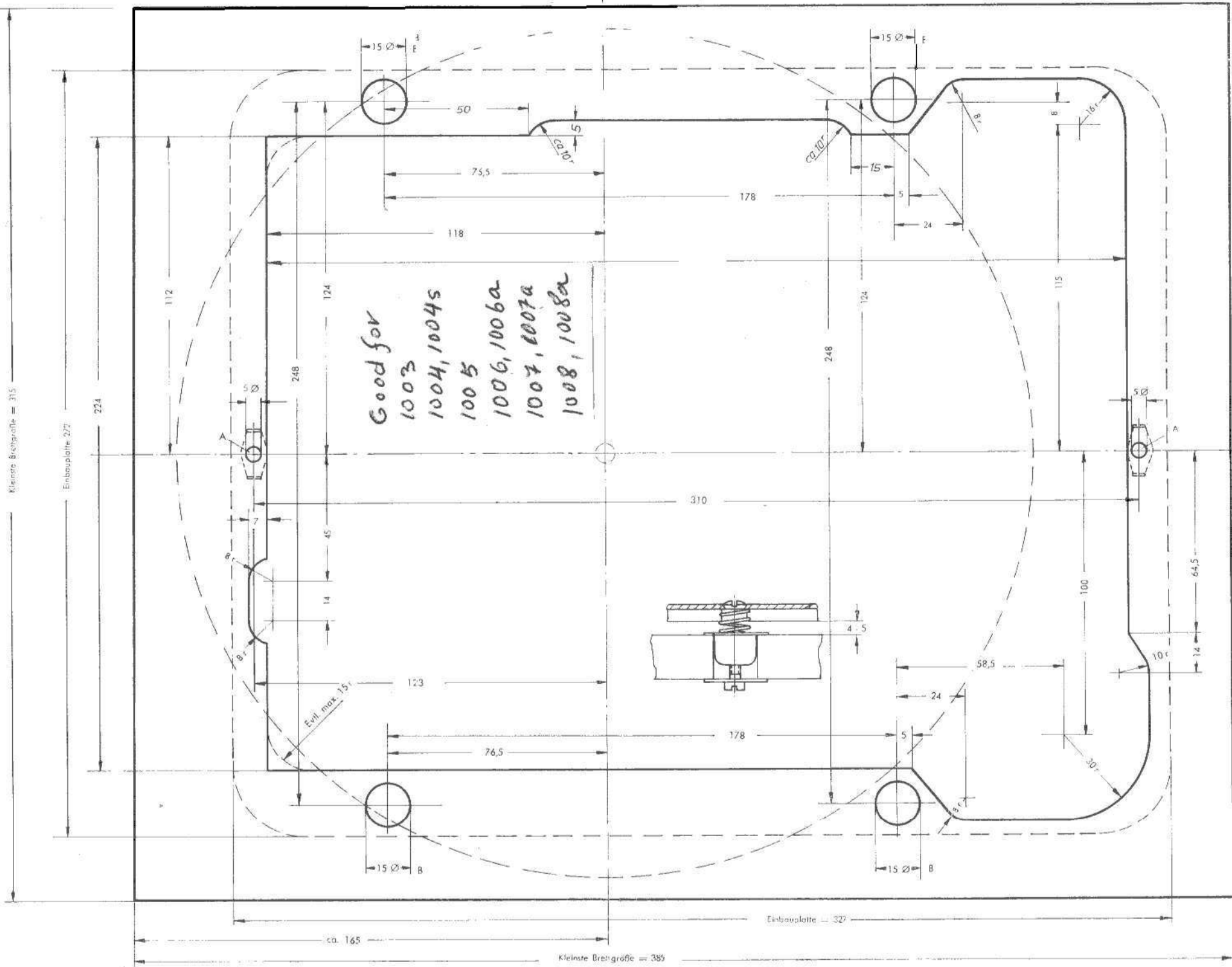

7. Trouble Chart

(The key numbers correspond with the numbers shown in the following parts list)

Trouble	Cause	Remedy
Start:		
Changer does not start after start button has been depressed	a) Power switch (18) open b) Power switch (18) not actuated	a) Replace power switch, (18) b) Adjust switch Bracket (61) with adjustment screw (R 2, Figure 12)
Changer does not run despite proper power connection and intact switch	No current supplied to motor	Voltage selector (7) has not properly snapped into position Correct setting!
Motor runs, tone arm and turntable not moving	Speed selector in neutral "0" position (Transport position)	Adjust speed selector (72) to correct position
Changer runs and shuts off as soon as the tone arm sets down on record	Plunger (58) remains in rest position	Check tension spring (63) and replace if necessary
Motor runs but tone arm remains on rest	a) Drop-in spring of cam wheel (19) is defective b) Tension spring (81) of start lever (16a) is defective or missing	a) Replace cam wheel (19) b) Replace tension spring (81)
Tone Arm does not set down at edge of record	a) Adjustment of tone arm incorrect b) Record size is not standard	a) Bend lip (R 8, Fig. 12) of segment (20) in accordance with adjustment instructions b) Use standard size records only
Operation:		
Records are not dropped	a) Drop rocker (5) has insufficient lift b) Changing spindle is not locked c) Changing spindle is defective	a) Re-adjust eccentric screw (R 1, Fig. 12) b) Lock spindle by clockwise turn c) Replace spindle
Turntable slows down at time of record drop	Drop rocker (5) has too much lift	Re-adjust eccentric screw (R 1, Fig. 12)
Turntable does not reach correct speed	a) Power line off correct frequency b) Slippage in drive system	a) Check power line frequency, possibly replace motor pulley (130) with positive or negative tolerance (available upon request) b) Clean drive wheels (110, 111, 112, 112a, 126, 130) of oil and grease. Replace worn wheels

Trouble	Cause	Remedy
	c) Excessive friction in bearings of motor and drive wheels	c) Clean gummed-up bearings in motor and drive wheels and re-lubricate (in accordance with lubrication instructions)
A record drops each time the stop button or the start button is depressed	Normal operation	Refer to functions of operation
After playing a stack of records of different sizes and renewed start, the pick-up will not set down at the edge of the top record	Normal operation	For single play, place only one record on turntable
Tone arm remains in run-out groove after completion of play	a) The run-out groove is not standard b) Shut-off lever (H, Fig. 6) stuck to cam wheel (19) c) Shut-off lever or engaging spring (F, Figure 6) of cam wheel (19) was bent when mounting turntable on changer	a) Do not use this record b) Clean cam wheel (19) and shut-off lever c) Re-adjust shut-off lever and spring with turntable removed or replace entire cam wheel
Dropping points on plunger (58) and on record are inaccurate	Friction surface of segment (20) not free from grease	Thoroughly clean segment (20) and control pimple on leaf spring of main lever (12) with grease-cutting solvent (methyl-hydrate)
The last record of a stack repeats continuously	The engagement between switchover lever (26) and shift lever (14) is too loose	Adjust switchover lever (26) in accordance with adjustment instructions
Unit shuts off after each record	The engagement between switchover lever (26) and shift lever (14) is too tight	Adjust switchover lever (26) in accordance with adjustment instructions
After drop of a 12" record, the arm sets down at the 10" point	Tension spring (77) defective	Replace tension spring (77)
Motor does not shut off upon returning of tone arm to rest position, despite intact power switch	Capacitor (142) is defective	Replace capacitor (142)
Reproduction		
Reproduction is unsatisfactory and distorted	a) Incorrect matching b) Stylus worn out or chipped c) Pick-up cartridge damaged	a) Input impedance of the amplifier must be 1 megohm per channel b) Replace stylus c) Replace pick-up cartridge
Howling sound on playback, particularly when boosting bass	Acoustical feed-back	Check spring suspension (10). Chassis must float freely. Connecting cords must not be tight.

8. Explosive View Fig. 14. parts above chassis

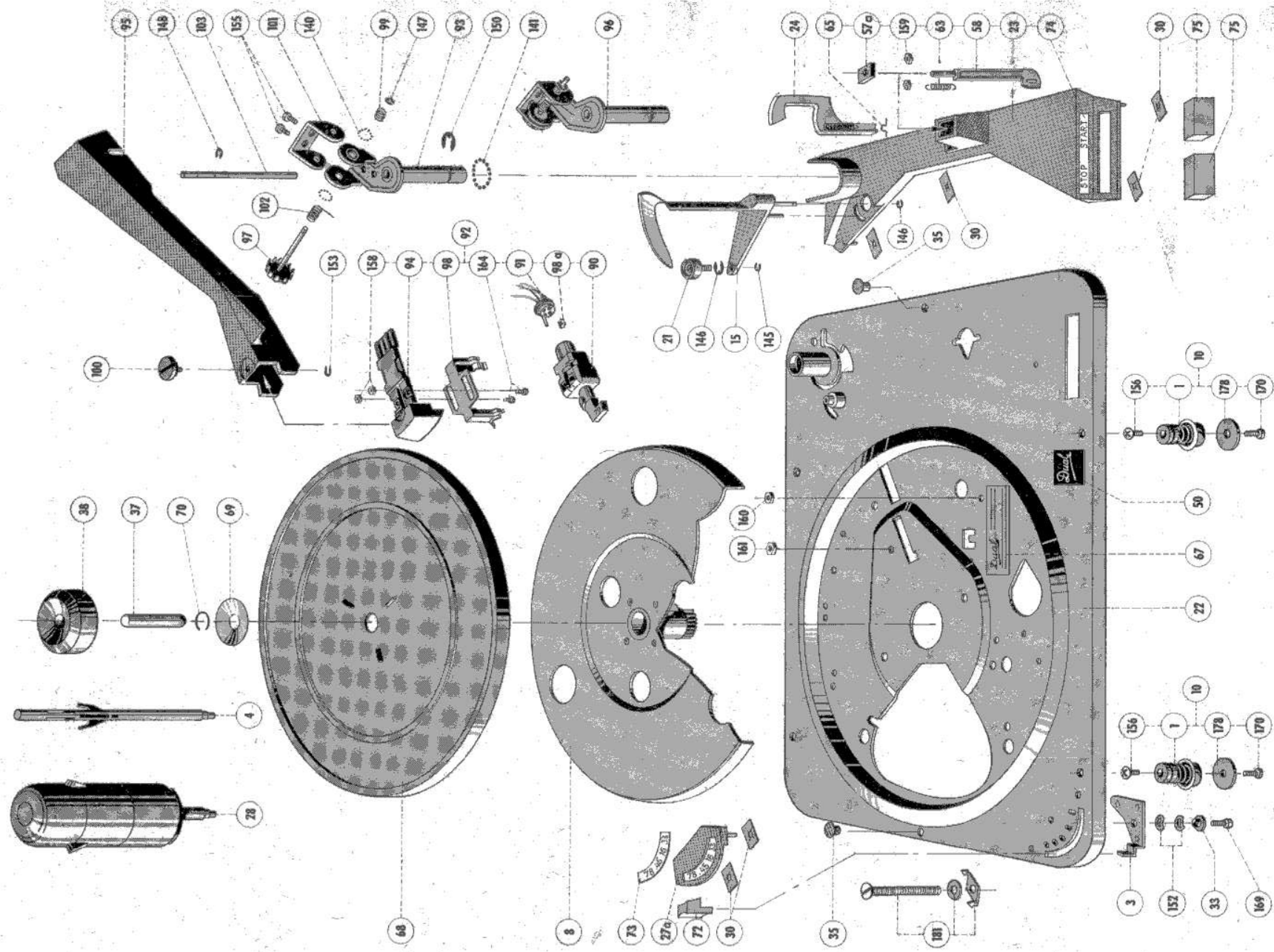
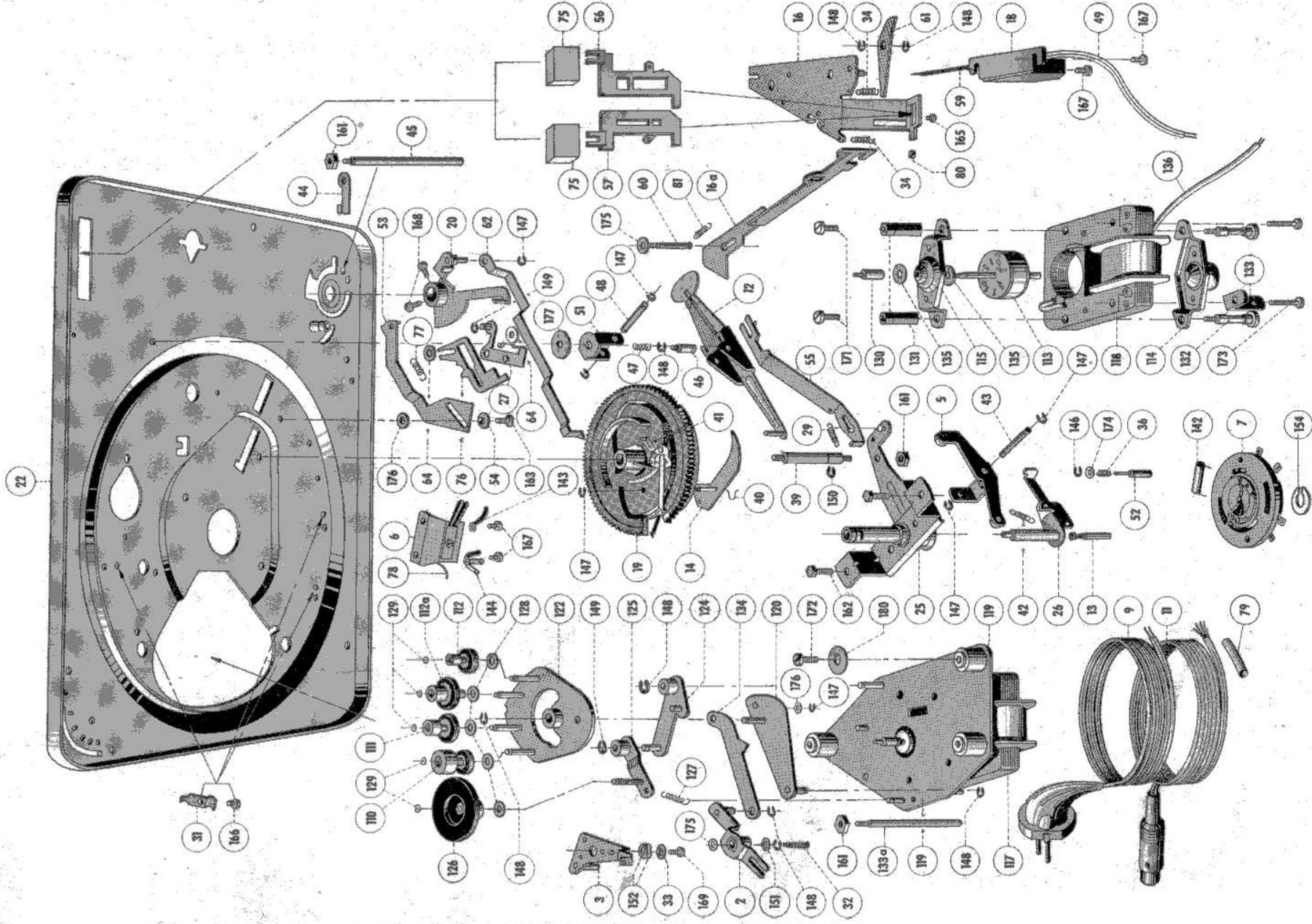

Fig. 15, parts below chassis



9. Spare Parts List

Ref. No.	Part No.	Description	Quantity
		Chassis and Mechanism	
1	12A-U 249	Cup with spring	4
2	12B-U 24	Switch piece, complete	1
3	12B-U 28	Switch lever, complete	1
4	12C-U 208	Changer spindle AW 2	1
5	12D-U 60	Drop rocker, complete	1
6	12D-U 110	Muting switch	1
7	12D-U 119	Voltage selector, compl., les capacitor	1
8	12D-U 130	Turntable, complete	1
9	12D-U 140	Line cord	1
10	12D-U 170	Spring suspension compl. (1 set 4 pcs.)	4
11	12D-U 176	Pick-up cable complete	1
12	12D-U 404	Main lever, complete	1
13	12D-U 411	Changer bolt, complete	1
14	12E-U 6	Shift lever, complete	1
15	12E-U 7	Feeler arm, complete	1
16	12E-U 10	Switch plate, complete	1
16a	12E-U 220	Start lever	1
17*	12E-U 216	Hi-Fi turntable, complete	1
18	12E-U 25	Power switch (Microswitch) compl.	1
19	12E-U 27	Cam wheel complete	1
20	12E-U 36	Segment, complete	1
21	12E-U 38	Feeler wheel, complete	1
22	12E-U 200	Unit plate, complete	1
23	12E-U 203	Cover, complete	1
24	12E-U 205	Lock, complete	1
25	12E-U 208	Bearing bracket, compl. with ball bearing	1
26	12E-U 209	Switchover lever, complete	1
27	12E-U 212	Link	1
27a	12E-U 214	Speed-setting plate	1
28	13D-Ausf. A	45 rpm automatic changer spindle AS 6	1
29	11 A- 10	Spring for lift rail	1
30	12A- 92	Spring clip	6
31	12A- 325	Cable clamp	3
32	12B- 40	Threaded bolt	1
33	12B- 50	Eyelet	1
34	12B- 135	Tension spring	2
35	12B- 364	Snap plug	2
36	12C- 224	Compression spring	2
37	12C- 294	Spindle short	1
38	12C- 297	Center piece for 45 rpm records	1
39	12D- 36	Bearing pillar for cam wheel	1
40	12D- 57	Snap ring	1
41	12D- 70	Tension spring for shut-off lever	1
42	12D- 96	Tension spring for switch lever	1
43	12D- 102	Shaft for drop rocker	1
44	12D- 167	Cable clamp	1
45	12D- 169	Pillar	1
46	12D- 184	Stud	1
47	12D- 194	Compression spring for bearing bracket	1
48	12D- 212	Shaft for main lever	1
49	12D- 300	Switch wiring	1
50	12D- 402	Dual emblem	1
51	12D- 407	Bearing bracket for main lever	1
52	12D- 414	Changer bolt	1
53	12E- 11	Setting lever	1
54	12E- 12	Shoulder spacer	1
55	12E- 16	Lift rail	1
56	12E- 31	Start bar	1
57	12E- 33	Stop bar	1
57a	12E- 34	Magnet for tonearm rest	1
58	12E- 36	Plunger	1
59	12E- 37	Switch lever for power switch	1
60	12E- 40	Grooved shaft	1
61	12E- 44	Switch link	1
62	12E- 49	Shut-off rail	1
63	12E- 51	Spring for power switch	1
64	12E- 55	Spacer	1
65	12E- 56	Wire	2
66*	12E- 213	Rubber mat for Hi-Fi Turntable	1
67	12E- 203	Designation plate	1
68	12E- 211	Rubber mat for standard turntable	1
69	12E- 212	Cover disc	1
70	12E- 214	Spring ring	1
72	12E- 216	Switch key	1
73	12E- 217	Speed selector plate	1
74	12E- 218	Start / Stop plate	1
75	12E- 219	Push button	1
76	12E- 222	Dog	2
77	12E- 223	Spring for setting lever	1
78	D 402/20	Jumper wire	1
79	J 57 nf/26	Insulated sleeving	1
80	4040/40	Rubber cap	1
81	5933/11	Spring for start lever	1
82*	12E- D 50	Operating instruction manual, 4 language version	1
		Tonearm	
90	14J - U 32	Stereo crystal cartridge CDS 620 / 4 / 45 compl. with styl DN 4 and DN 45	1

Ref. No.	Part No.	Description	Quantity
91	14 J - U 84	Clip for cartridge	1
92	14 J - U 132	Pick-up head "D" compl. with stereo crystal cartridge CDS 620/4/45 and styli DN 4 and DN 45	1
93	15 L - U 6	Bearing bracket, complete	1
94	15 L - U 11	Plug-in head without cartridge	1
95	15 M - U 1	Tonearm, compl.	1
96	15 M - U 5	Tonearm bearing, complete	1
97	15 M - U 6	Bearing shaft, complete	1
98	14 J - 8	Retaining spring for cartridge	1
98a	14 J - 13	Jumper for cartridge	1
99	15 G - 76	Compression spring	1
100	15 L - 4	Locking button	1
101	15 L - 17	Bearing bracket	1
102	15 L - 24	Spring spiral	1
103	15 L - 27	Lift rod, with 3 grooves	1
		Motor	
110	12 B - U 42	Intermediate wheels, 78 rpm, compl.	1
111	12 B - U 44	Intermediate wheels, 45 rpm, compl.	1
112	31 E - U 88	Intermediate wheels, 33 rpm, compl.	1
112a	31 G - U 60	Intermediate wheels, 16 rpm, compl.	1
113	31 F - U 19	Armature (rotor) compl.	1
114	31 F - U 33	Bearing bracket, lower, complete	1
115	31 F - U 37	Bearing bracket, upper, complete	1
116*	31 G - Ausf. A	Motor complete with drive	1
117	31 G - U 3	Motor with motor pulley	1
118	31 G - U 4	Stator	1
119	31 G - U 44	Motor mounting plate, complete	1
120	31 G - U 46	Rocker, complete	1
121*	31 G - U 48	Switch segment, compl. with intermediate wheels	1
122	31 G - U 50	Switch segment	1
124	31 G - U 64	Lifter compl.	1
125	31 G - U 68	Swing lever, complete	1
126	31 G - U 72	Idler wheel	1
127	11 A - 10	Tension spring	1
128	11 C - 138	Washer	5
129	12 B - 86	Washer, seal	5
130	31 B - 50	Motor pulley 50 cps (31 B - 63 = 60 cps)	1
131	31 G - 45	Pillar (motor)	2
132	31 F - 59	Screw	2
133	31 F - 61	Angle	1
133a	31 G - 68	Rest post	1
134	31 G - 74	Shift lever	1
135	31 F - 78	Washer	2
136	J 60 sw/60	Insulated Sleevings	1
		Standard Parts	
140	4000/150	Precision ball, 1,5 mm diameter	18
141	4000/200	Precision ball, 2 mm diameter	14
142	4020/64	Capacitor, 0,1 µF 250 V ~	1
143	4103/27	Solder lug	1
144	4103/29	Solder lug	1
145	4650/1,2	"C" washer 1,2 DIN 6799	1
146	4650/1,5	"C" washer 1,5 DIN 6799	3
147	4650/2,3	"C" washer 2,3 DIN 6799	8
148	4650/3,2	"C" washer 3,2 DIN 6799	8
149	4650/4	"C" washer 4 DIN 6799	2
150	4650/6	"C" washer 6 DIN 6799	1
151	4680/4,2/8d	Washer, cup shaped	1
152	4680/5,2/10a	Washer, cup shaped	2
153	4693/4	Snap ring G 4 x 0,8	1
154	4693/8	Snap ring G 8 x 1	1
155	L 3/5 a	Oval head screw AM 3 x 5	2
156	LSK 3/6 a	Oval head screw AM 3 x 6	4
158	M 2,6/4 b	Nut BM 2,6	2
159	M 3/4	Nut M 3	2
160	M 3/7 a	Nut BM 3	4
161	M 4/2	Nut BM 4	1
162	6 k 4/4	Screw M 4 x 4	2
163	S 3/5 a	Screw AM 3 x 5	1
164	Z 2,6/5 a	Screw AM 2,6 x 5	2
165	Z 3/3 c	Screw AM 3 x 3	1
166	Z 3/4 d	Screw AM 3 x 4	3
167	Z 3/4,5 a	Screw AM 3 x 4,5	4
168	Z 3/5 a	Screw AM 3 x 5	2
169	Z 3/6 b	Screw AM 3 x 6	1
170	Z 3/14 a	Screw AM 3 x 14	4
171	Z 3,5/7 d	Screw	2
172	Z 4/8 a	Screw AM 4 x 8	3
173	Z 4/18 a	Screw AM 4 x 18	2
174	2,1/5/0,5 St	Washer	1
175	3,2/8/0,5 St	Washer	2
176	3,2/10/0,5 St	Washer	2
177	3,2/18/1 St	Washer	1
178	3,2/20/1 St	Washer	4
180	4,2/14/2 St	Washer	3
181	4,2/10/0,5 PS	Transport security consisting of:	2
	12 A - 412	Drive nut	2
	LS 4/38 b	Oval head screw	2

*) Part not shown

10. Wiring Diagram

Motor

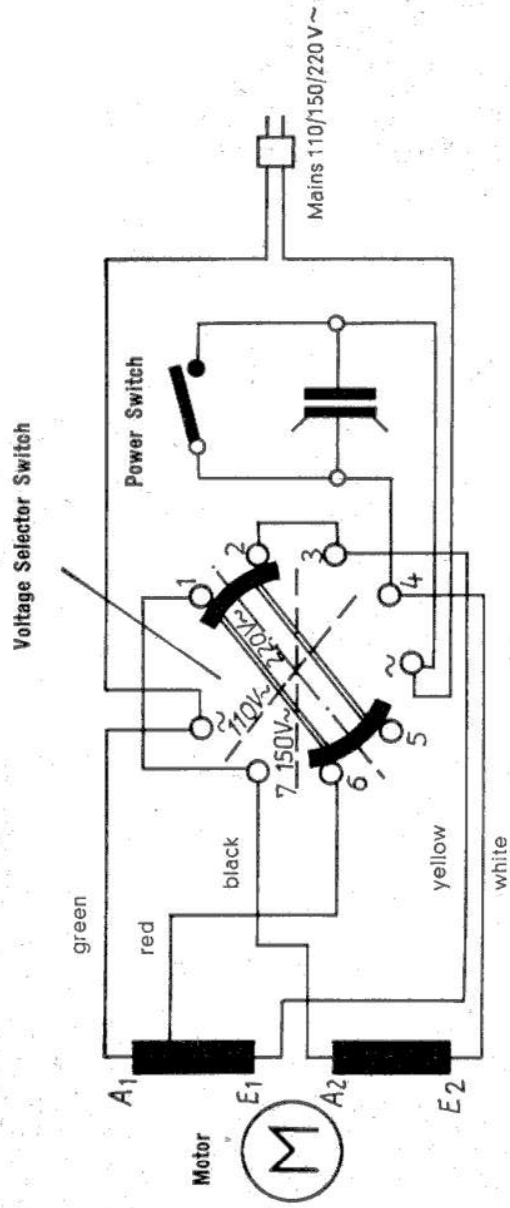

Pick-up

