

Dual

Service-Anleitung
Service Manual
Instructions de Service

CD 100 RS



Technische Daten Meßwerte = typische Werte	Technical data Measured values = typical values	Caractéristiques techniques Valeurs mesurées = valeurs typiques	Dati tecnici Valori di misuri = valori tipici	Dual CD 100 RS
Frequenzbereich	Frequency response	Courbe de réponse	Banda do Frequenza	20-20 000 Hz \pm 0,7 dB
Geräuschspannungsabstand	Signal to noise ratio	Rapport signal/bruit	Rapporto segnale disturbo	103 dB
Dynamikbereich	Dynamic range	Dynamique	Dinamica	96 dB
Übersprechdämpfung (1 kHz)	Crosstalk (1 kHz)	Diaphonie (1 kHz)	Diafonia	92 dB
Klirrfaktor (1 kHz)	Harmonic distortion (1 kHz)	Distorsion harmonique (1 kHz)	Distorsione armonica	< 0,01 %
Gleichlaufschwankungen	Wow and flutter	Tolérance de vites	Tolleranza di velocità	< \pm 0,001 %
Ausgangsspannung	Output voltage	Tension de sortie	Tensione di uscita	2 V
Max. programmierbare Musiktitel	Max. music title programming	Titres de musique au max. programmé	Programmazione di pezzi musicale	30
D/A Wandler	D/A Converter	D/A Convertisseur	Quantizzazione	18 Bit
Abtastfrequenz	Sampling frequency	Fréquence de pick-up	Frequenza di campionatura	352,8 kHz
Abtastsystem	Pick up	Pick up	Testina di lettura	3-Strahl-Laser 3-beam optical pick up
Leistungsaufnahme	Power consumption	Consommation	Potenza assorbita	10 W
Netzspannung Model Europa Model USA/Kanada	Mains voltage European model US/Canadian model	Voltage secteur Modèle Europe Modèle USA/Canada	Tensione di rete modello Europa modello Stati Uniti/Canada	230 V/50 Hz 115 V/60 Hz

Abgleichanleitung CD 100 RS

Um in den Testmode zu gelangen, gehen Sie wie folgt vor:

1. Power aus
2. Testpunkte P 03 (Gnd) und P 05 (Test) kurzschließen
3. Power ein (alle Segmente im Display leuchten)
4. Kurzschluß trennen
5. Durch Drücken der Taste Play kann Testmode 1, 2, 3 eingestellt werden
6. Testmode verlassen: Power aus

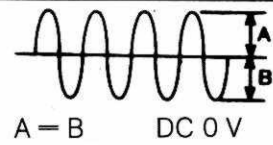
Signalquelle	Einstellung Gerät	Meßgeräteanschluß	Abgleichposition	Abgleichbemerkungen
	PLL			
	Testmode 1	1. Frequenzzähler an P 04 (PLCK) 2. P 02 und P 03 kurzschließen	VR 105	4,321 MHz
		3. Kurzschluß trennen		
Phillips 5 A	EF Balance			
	Testmode 2 CD vorsichtig mit dem Finger drehen	Osci an P 07	VR 101	 A = B DC 0 V
	Focus Balance			
	Testmode 3	Osci an P 01 (RF)	VR 102	Sauberes EFM-Signal ca. 1,4 V SS
	Focus Gain			
	Testmode 3	1. Millivoltmeter AC an P 09 2. mit Generator 1,2 kHz 460 mV über 10 kΩ an P 09	VR 104	Maximum -3 dB
Tracking Gain				
Testmode 3	AC-Voltmeter an P 08	VR 103	10 mV AC	

Alle Spannungen werden gegen GnD (P 03) gemessen

Der integrierte CD-Spieler arbeitet mit unsichtbarem Laserlicht.

Nicht in den Strahl blicken und nicht dem Strahl aussetzen!

Vorsicht, Laserstrahlung im Inneren des Gerätes!

Zur Vermeidung von Strahlungsschäden darf das Gehäuse nur von qualifiziertem Fachpersonal geöffnet werden.

Informationsetikett auf der Geräterückseite (siehe Bild).

The integrated CD-Player works with invisible laser-light.

Do not look into this beam and don't abandon yourself to radiation.

Attention, Laser-radiation also inside of the unit!

To avoid damages of radiation unit should be opened only by qualified service personnel.

Information label on the rear of unit (see picture).

VORSICHT!
UNSICHTBARE LASERSTRAHLUNG TRITT AUS, WENN DECKEL GEÖFFNET IST!
NICHT DEM STRAHL AUSSETZEN!
LASER KLASSE 1

CAUTION
INVISIBLE LASER RADIATION WHEN OPEN. AVOID EXPOSURE TO BEAM CLASS 1 LASER PRODUCT.

Tuning instructions CD 100 RS

Proceed as follows to enter the test mode:

1. Power OFF
2. Short-circuit test points P 03 GND to P 05
3. Power ON (all segments in Display are lighting)
4. Remove short circuit
5. Press the play key to set test mode 1, 2 or 3
6. To exit test mode: power OFF

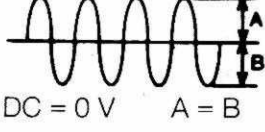
Signal source	Equipment setting	Connecting of measuring instrument	Item to be tuned	Tuning remarks
	PLL			
	Test mode 1	1. Frequency counter to P 04 (PLCK) 2. Short circuit P 02 to P 03	VR 105	4,321 MHz
		3. Remove short circuit		
Phillips 5 A	EF balance			
	Test mode 2 turn disc carefully with the fingers	Oscilloscope to P 07	VR 101	 DC = 0 V A = B
	Focus balance			
	Test mode 3	Oscilloscope to P 01 (RF)	VR 102	Clear EFM signal ca. 1,4 V SS
	Focus gain			
	Test mode 3	1. Millivoltmeter AC to P 09 2. with tone generator 1.2 kHz 460 mV via 10 kΩ to P 09	VR 104	Maximum -3 dB
	Tracking gain			
Test mode 3	AC-voltmeter to P 08	VR 103	10 mV AC	

All voltages are measured against earth (P 03)

Achtung:

Vor Ausbau des Pick-up bezeichnete Anschlußpunkte durch Verlöten kurzschließen.
Nach Einbau des reparierten bzw. neuen Pick-up Kurzschluß wieder trennen.

■ Cautions when removing the laser pick-up for repairing.

Before removing the laser pick-up, short-circuit the terminals by soldering.
This is to prevent damage to the pick-up during removal operation.

1. Solder the pick-up terminals.
2. Detach 2 lead connectors.

■ Cautions when replacing the laser pick-up.

1. Insert the 2 pick-up lead connectors into the connector PCB.
2. Detach the short-circuited pick-up terminal soldering.

* The terminal is factory soldered for protection, so use the same procedure when replacing the pick-up when a new one.

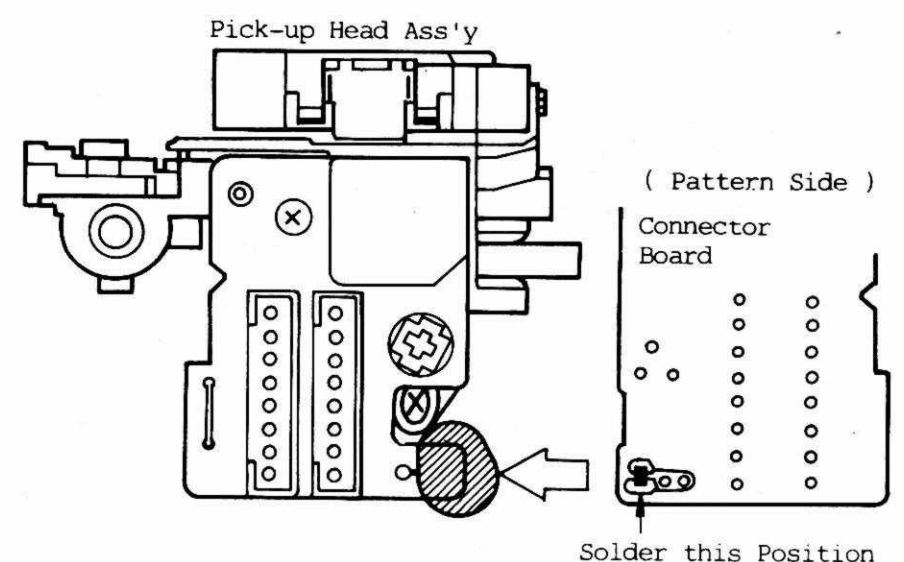

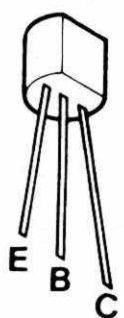
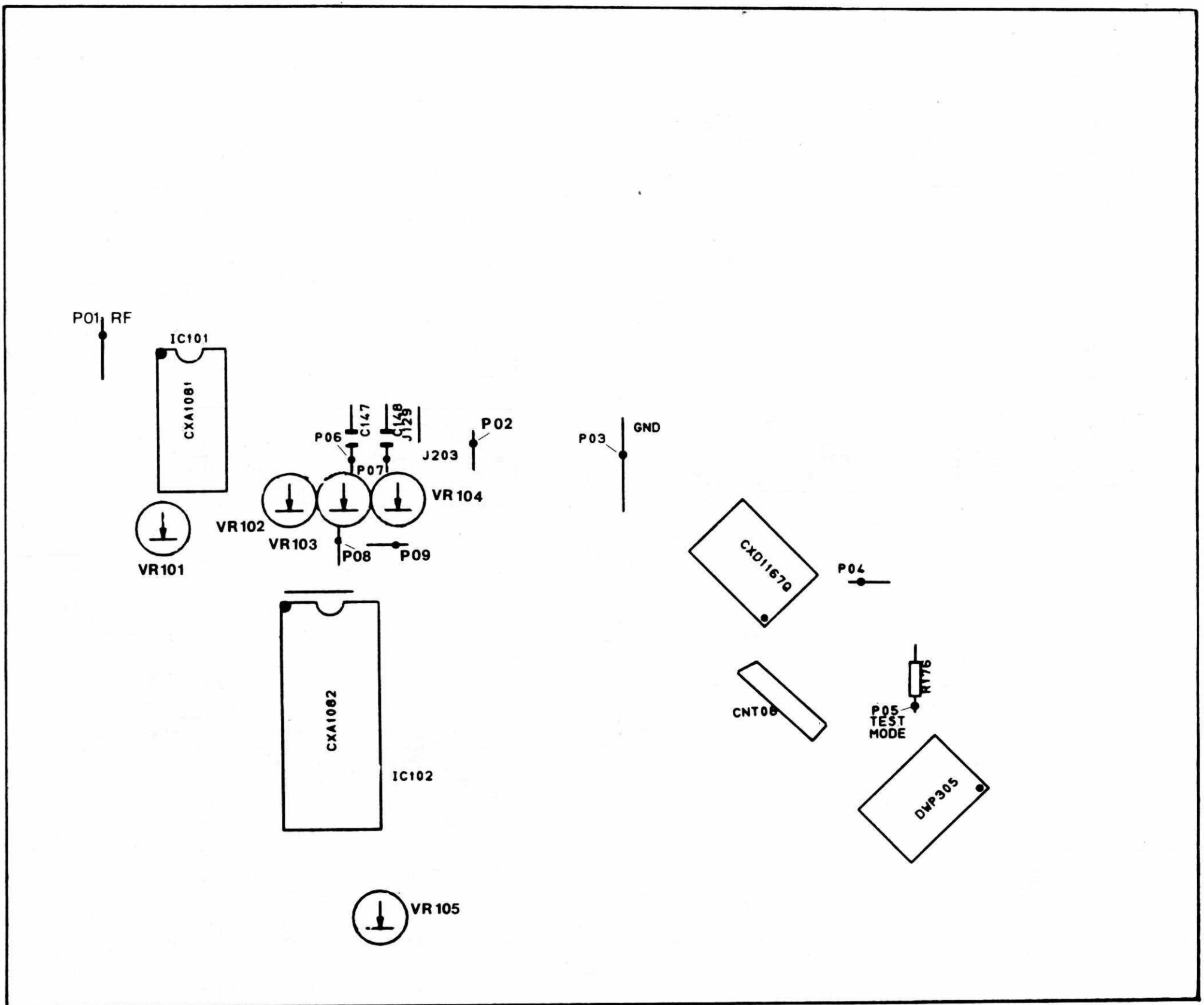

MPS A06
MPS A56



KTA 966 A
KTA 1015 Y
KTC 1815 Y
2 SD 1302 T



MC 7905 CT

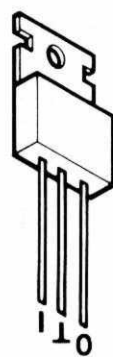

GD 7805

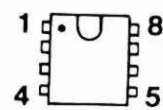

RC 4558 D

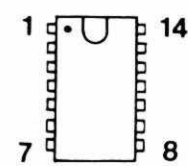

AD 1856 N
GD 74 LS 20

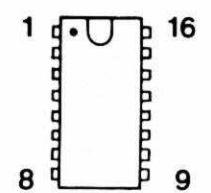

YM 4113 B 3
YM 3433

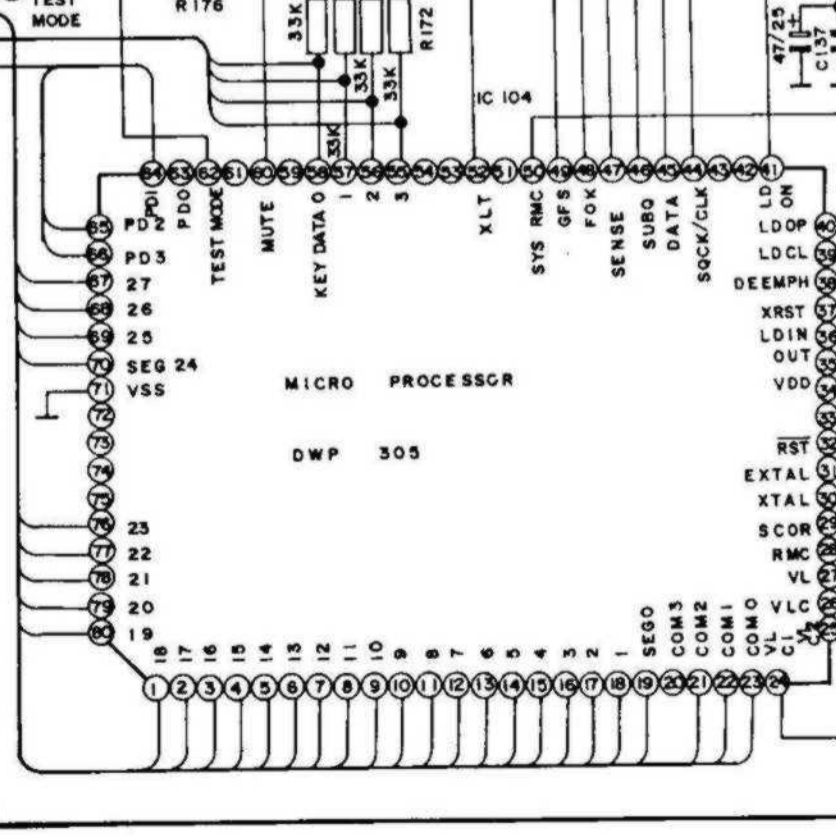
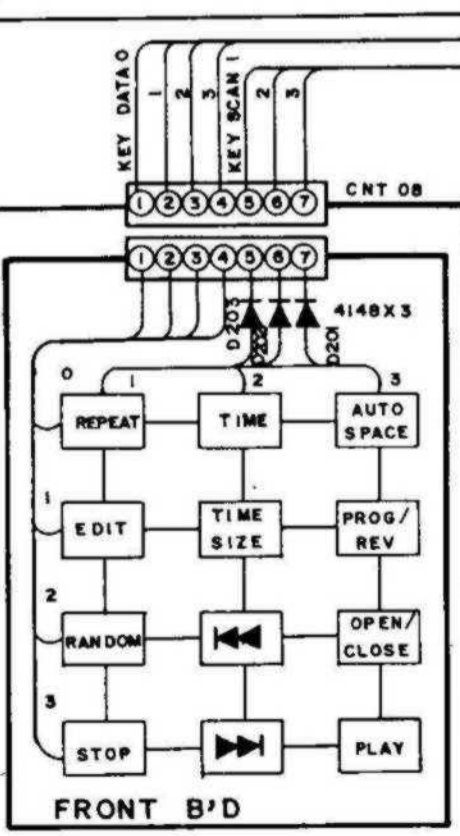
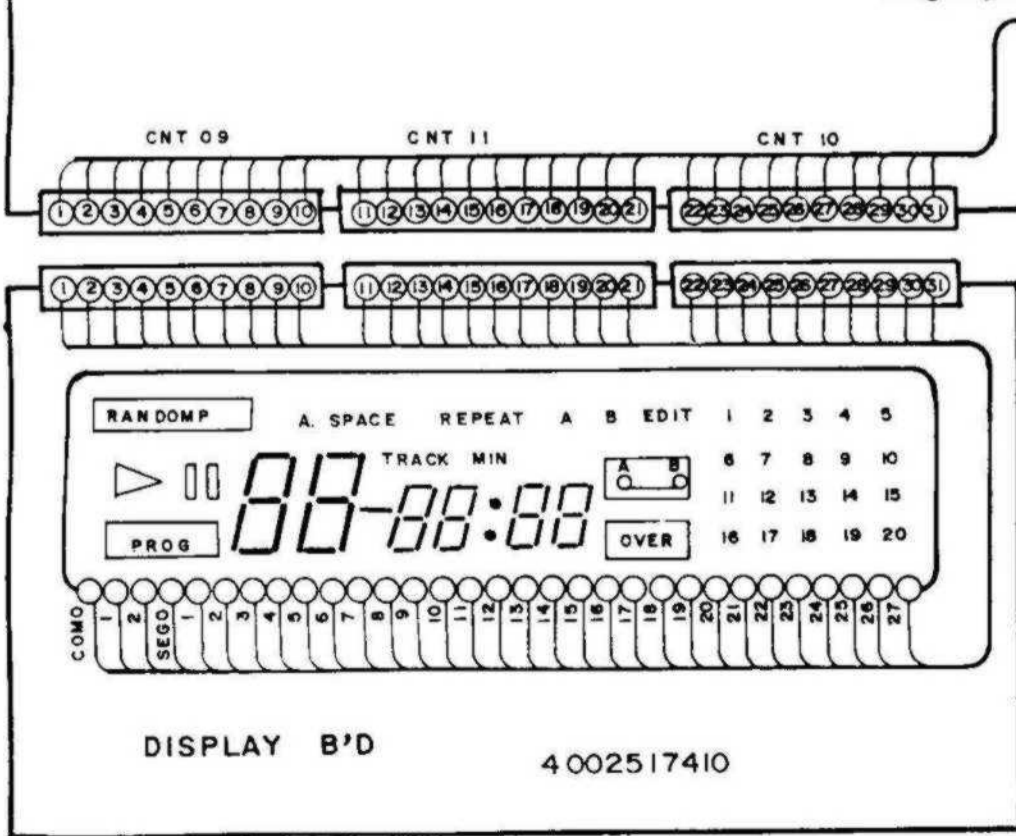
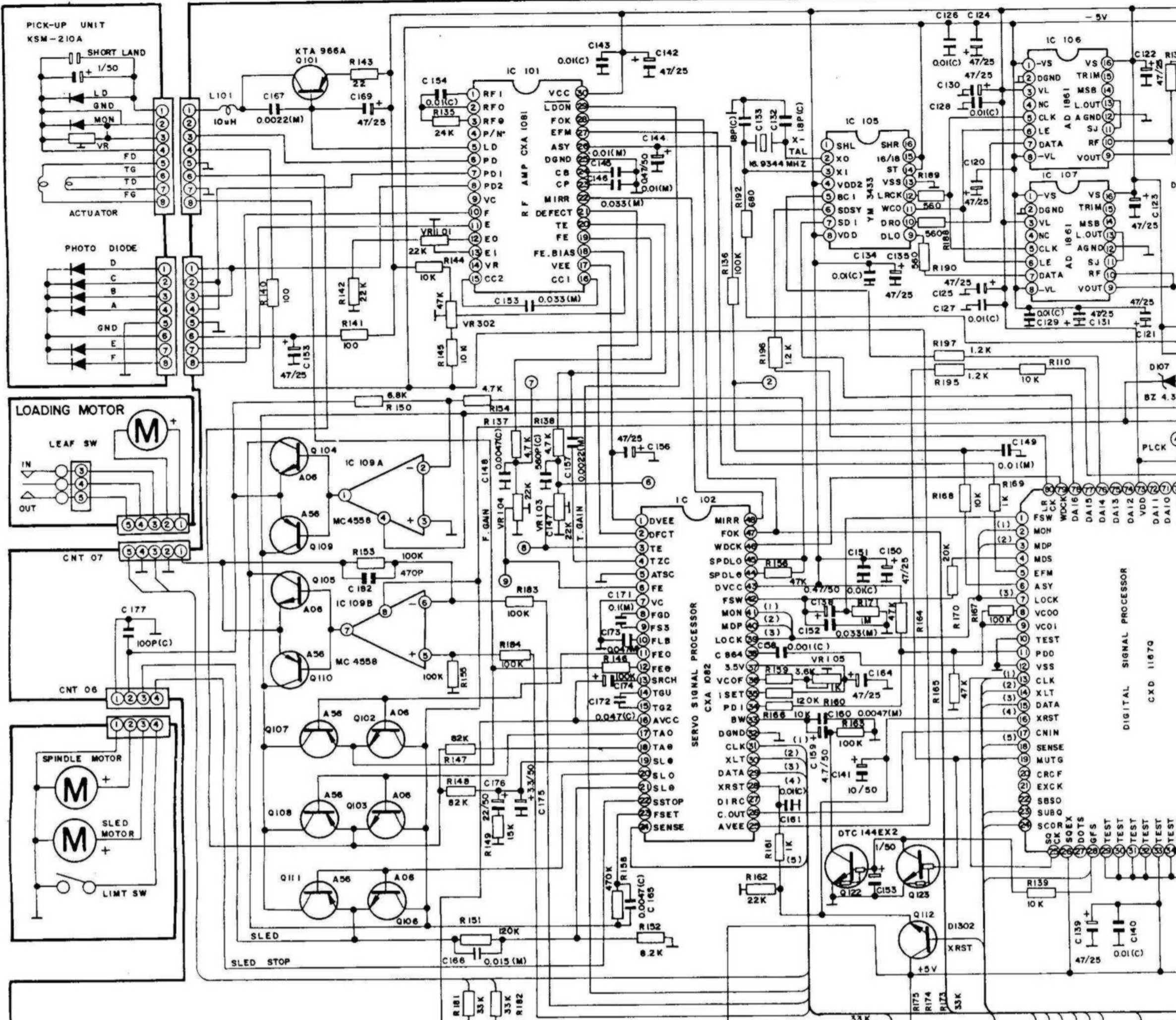

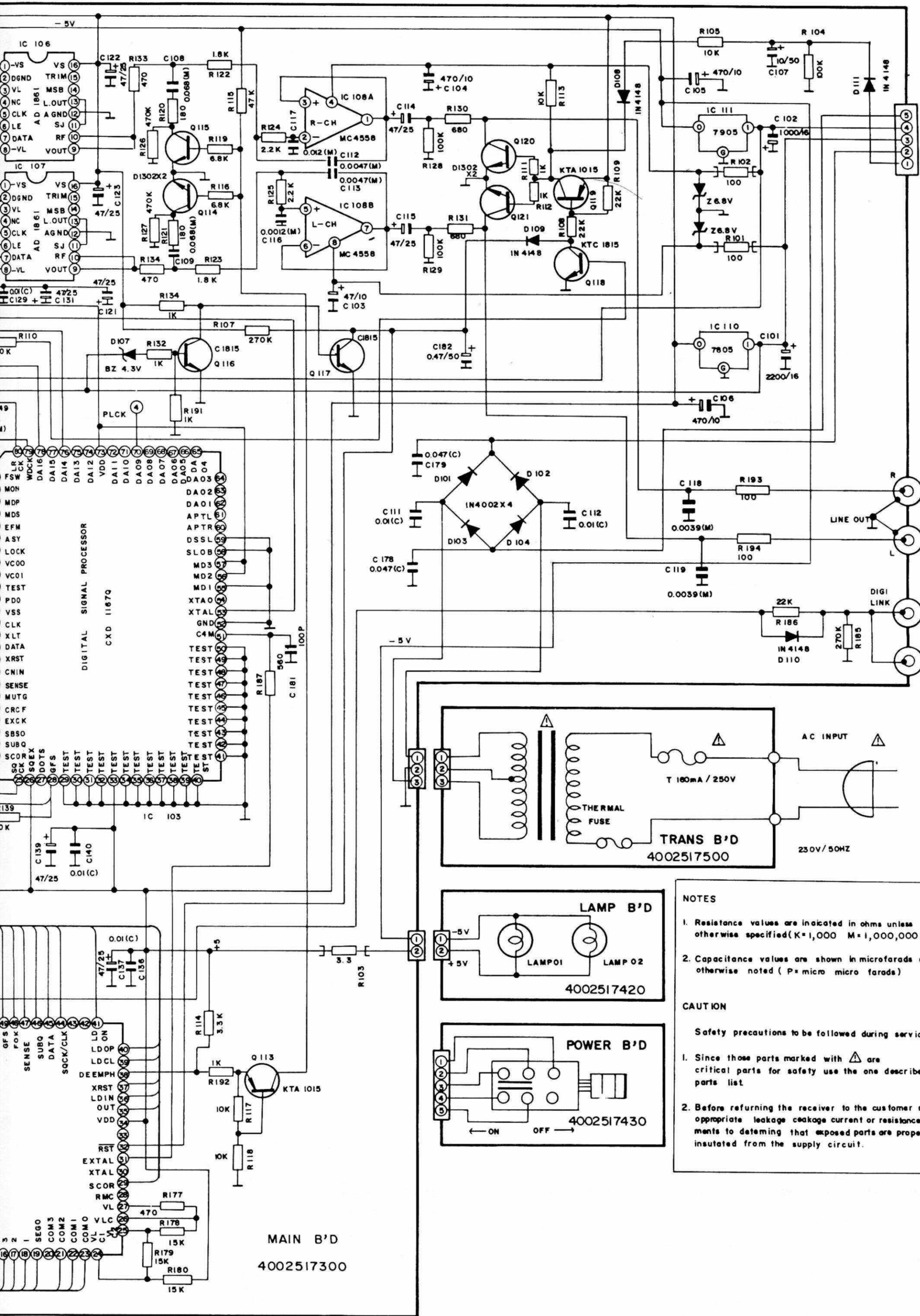

NOTES

- Resistance values are indicated in ohms unless otherwise specified (K=1,000 M=1,000,000)
- Capacitance values are shown in microfarads unless otherwise noted (P=micro micro farads)

CAUTION

Safety precautions to be followed during servicing

- Since those parts marked with Δ are critical parts for safety use the one described parts list
- Before returning the receiver to the customer make appropriate leakage ceakage current or resistance measurements to deteming that exposed parts are property insutated from the supply circuit.

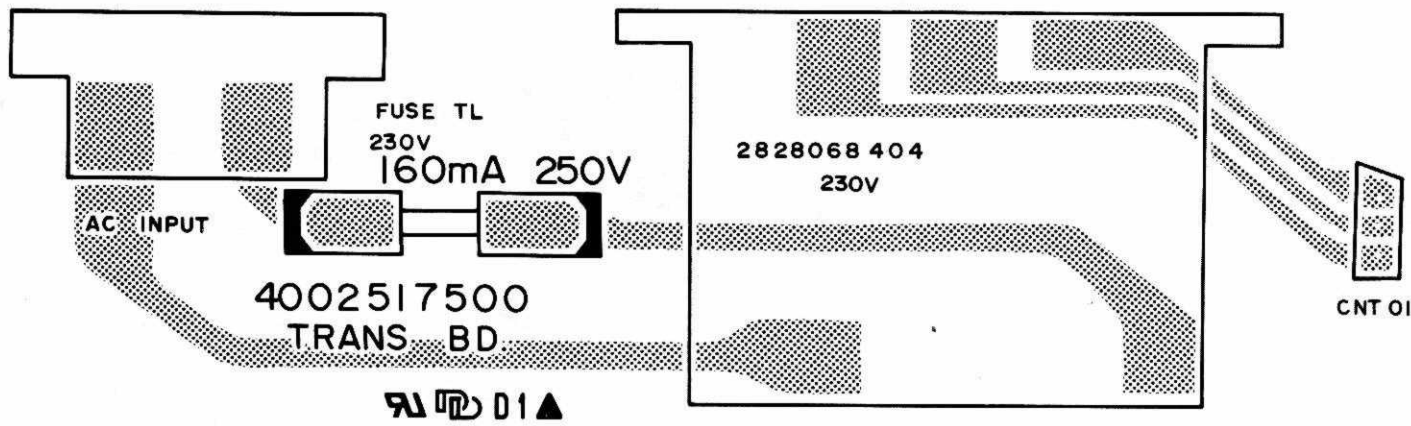

CXA1081M

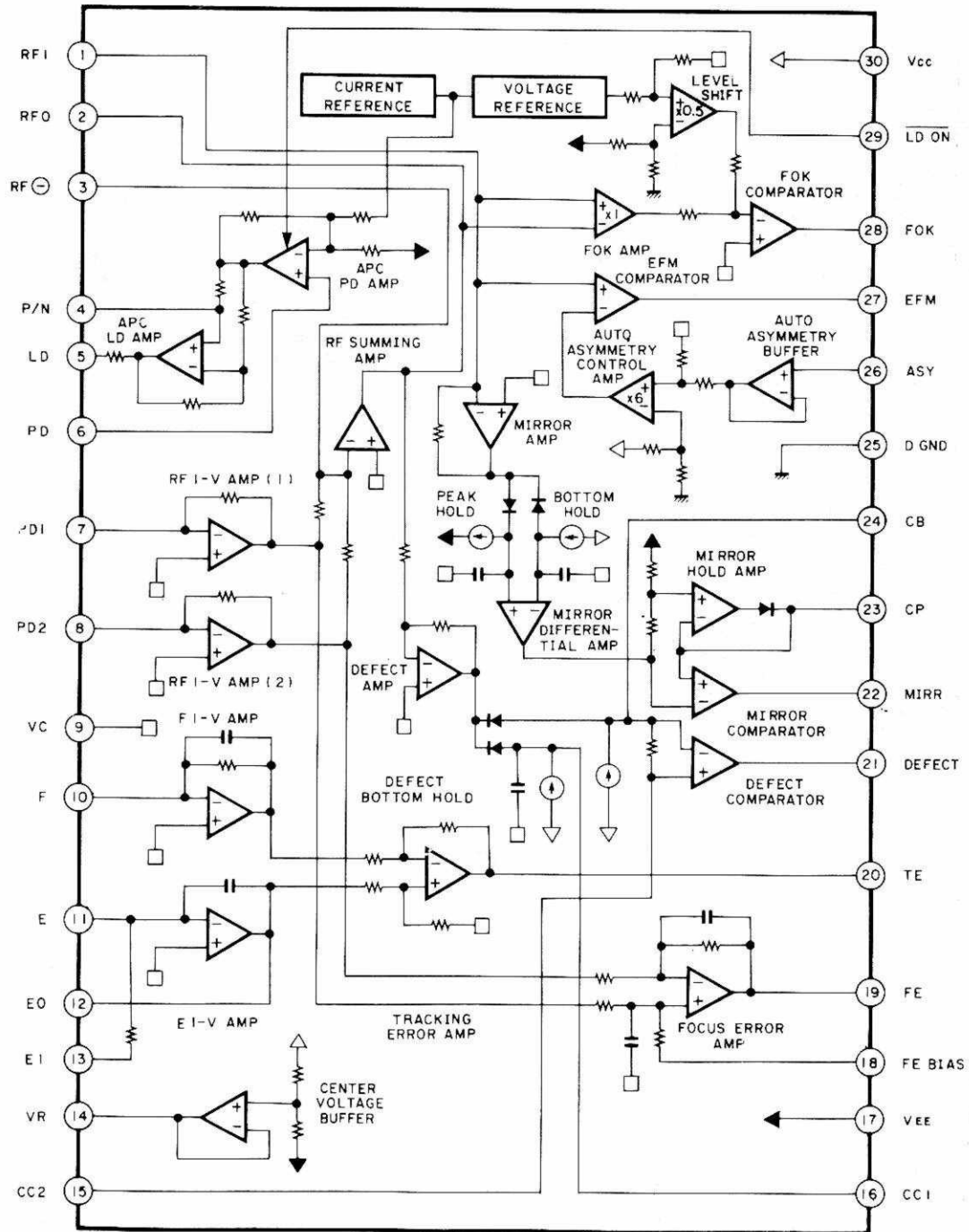

CXA1082AQ

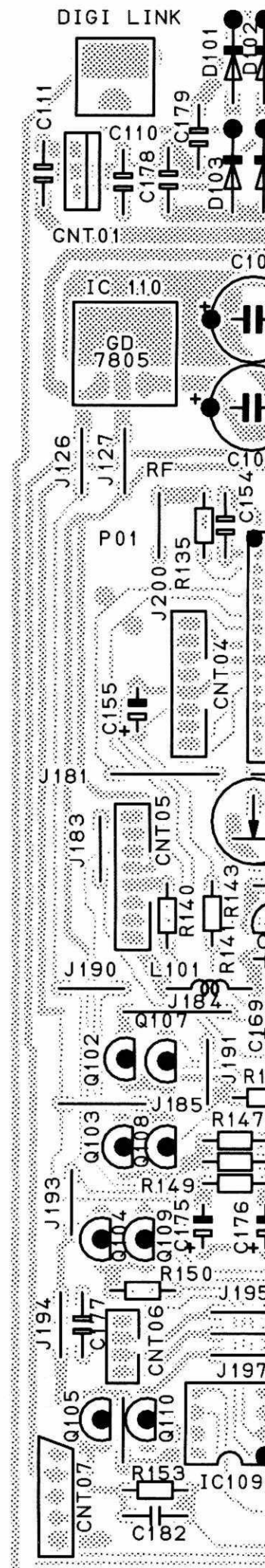
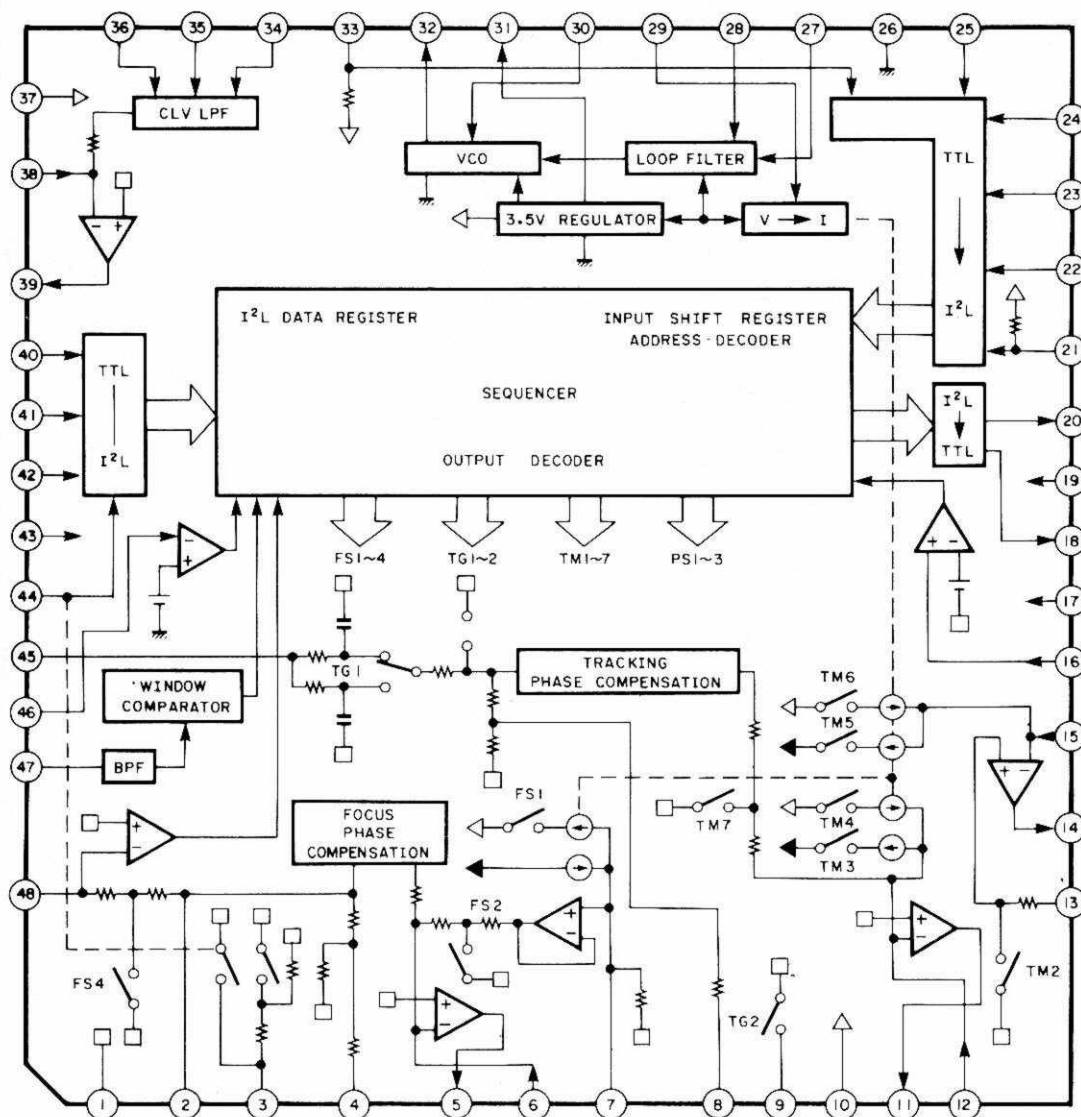

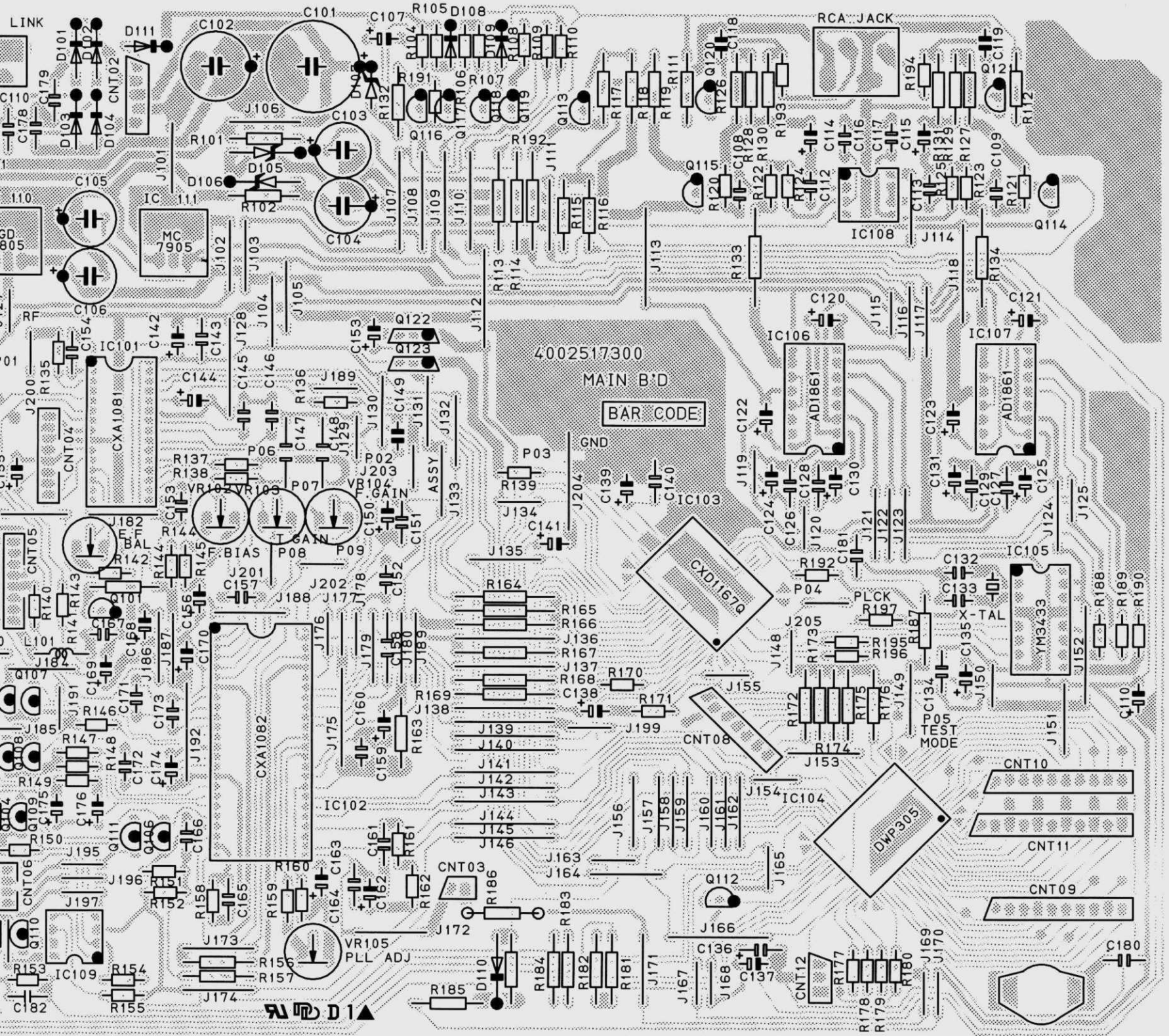

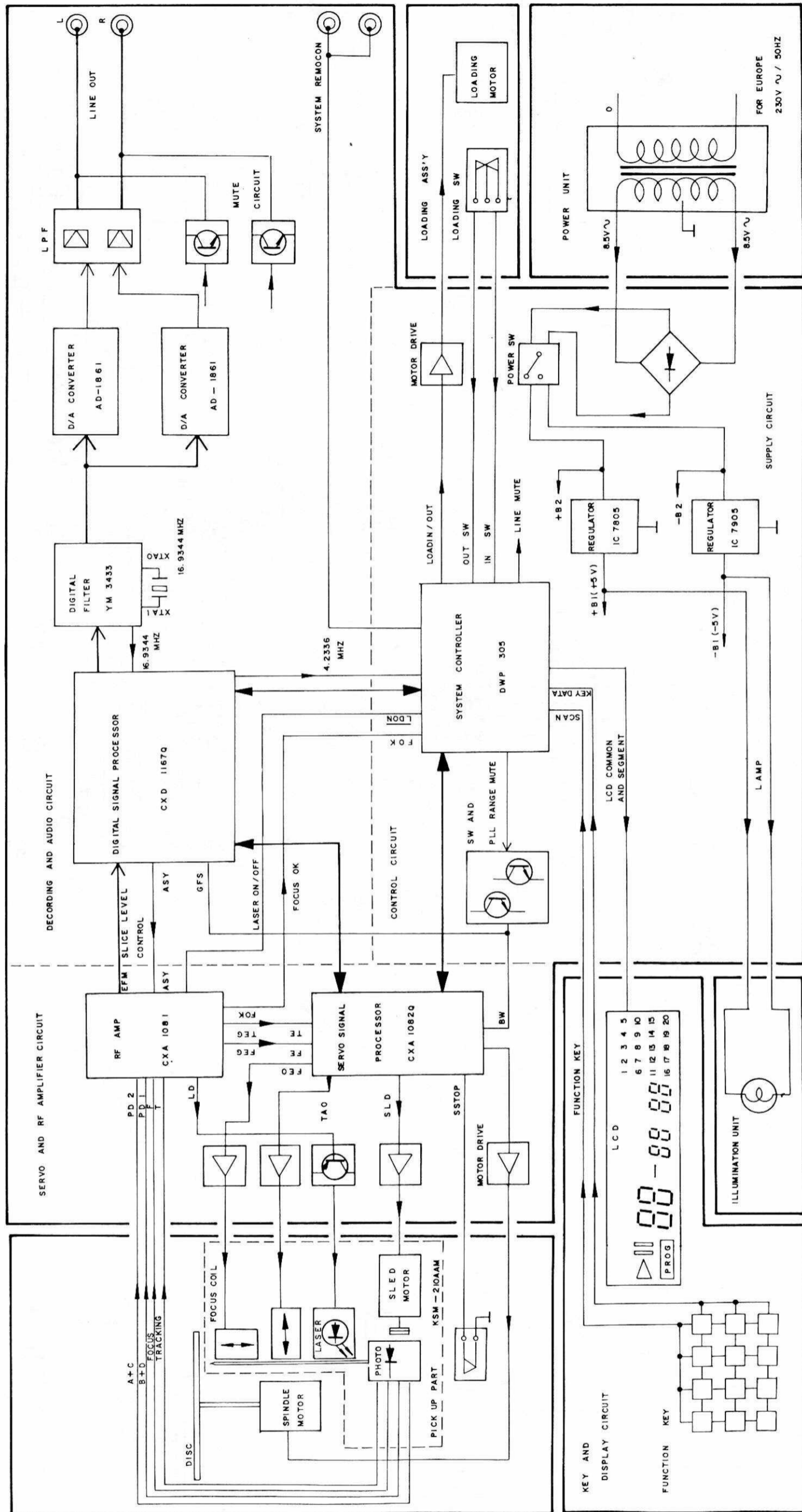

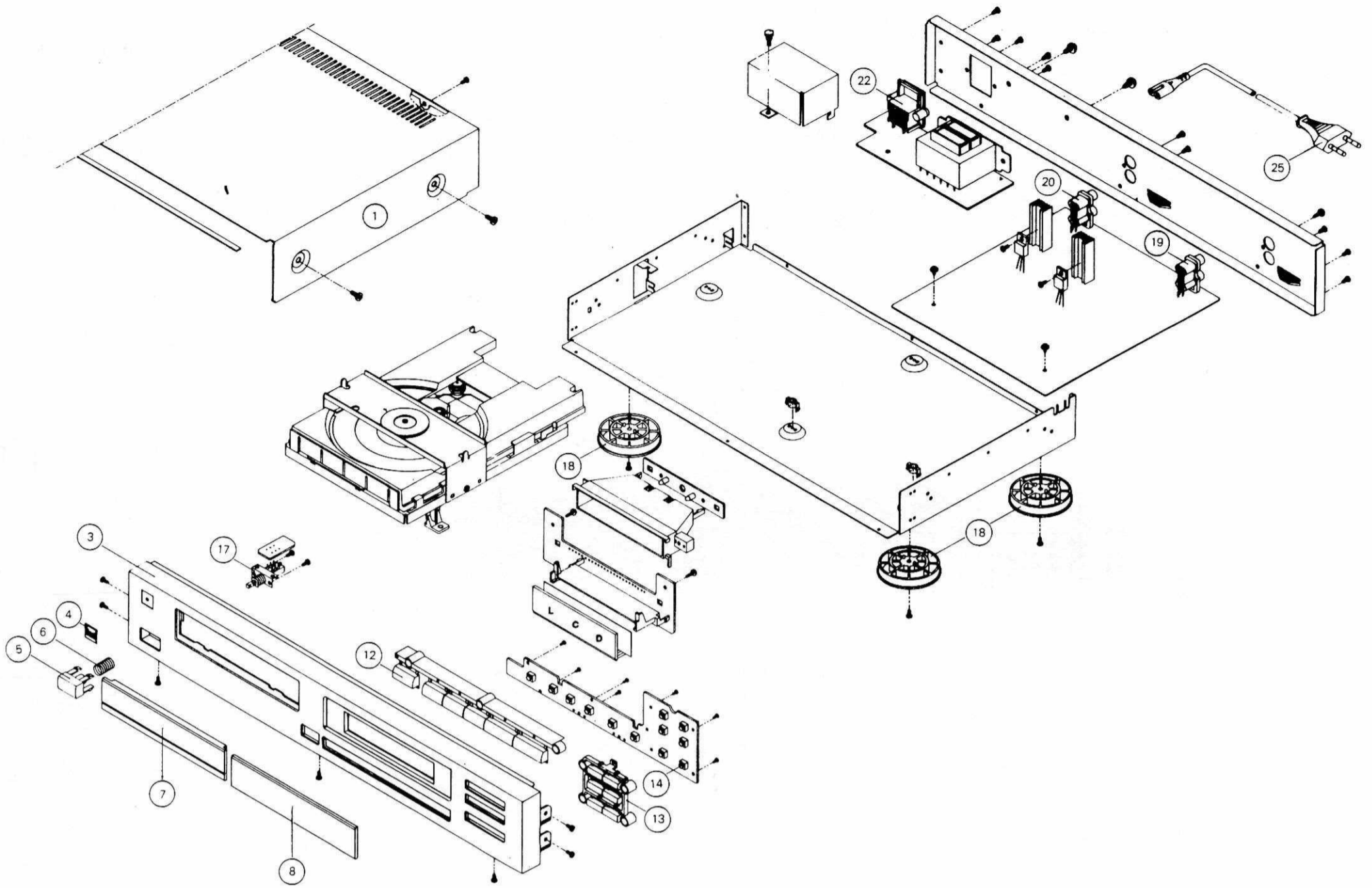

Mechanik

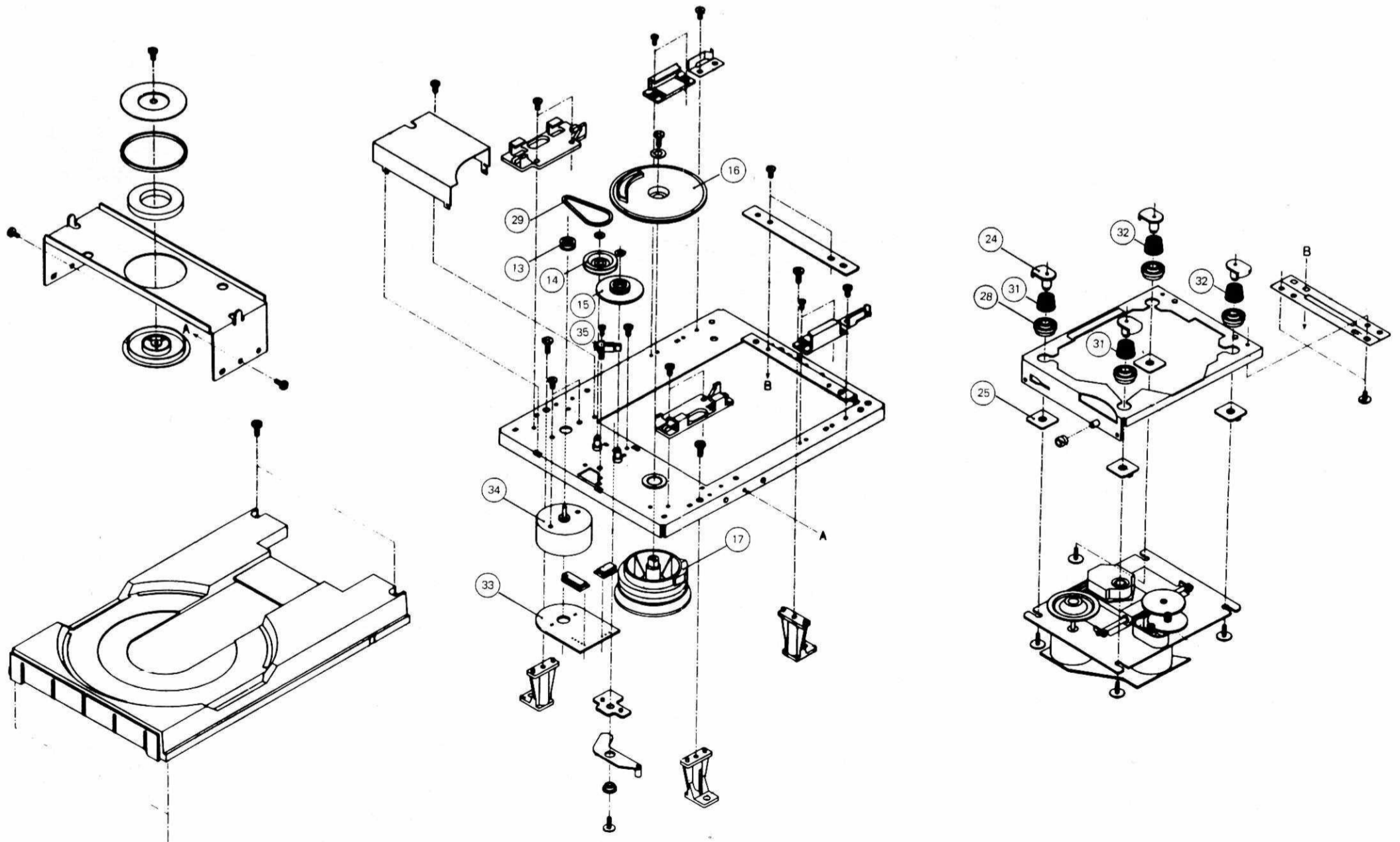

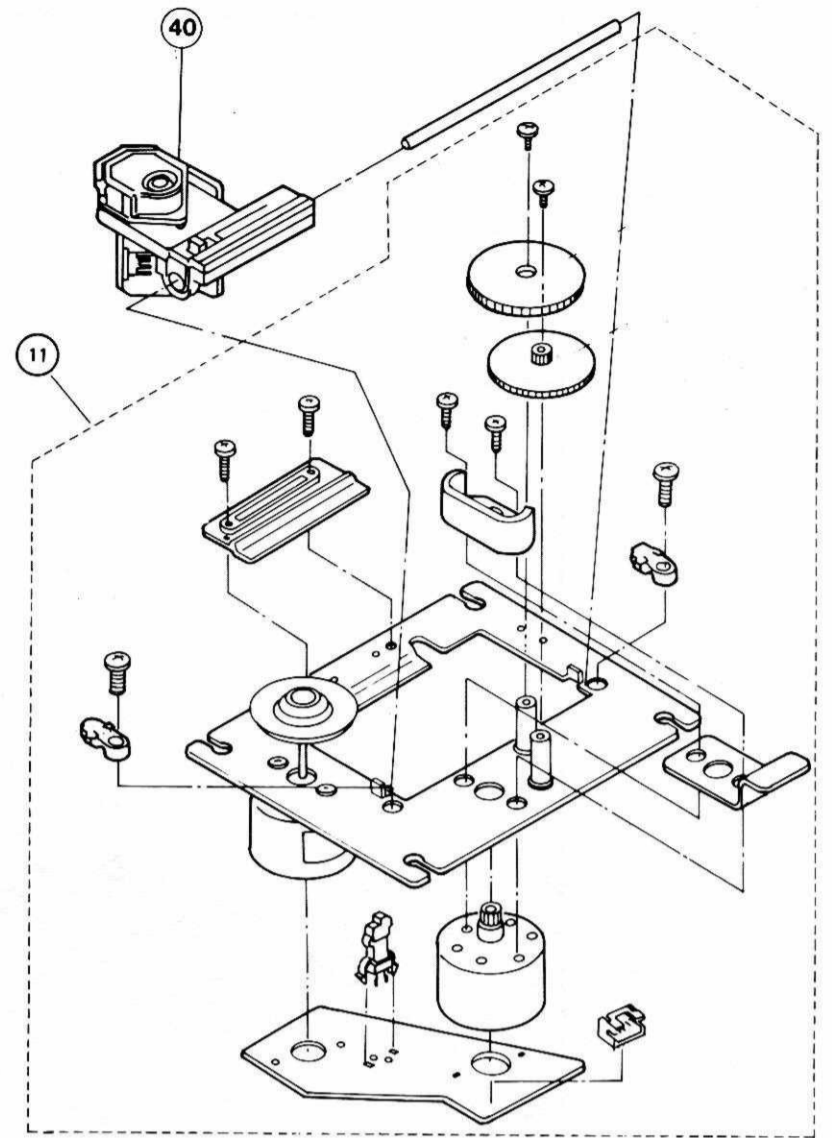

Ersatzteile · Replacement parts · Pièces détachées · CD 100

Pos.	Art.-Nr.	Bezeichnung
1	289 317	Gehäuseblech
3	289 318	Frontblende
4	283 750	DUAL-Zeichen
5	289 244	Taste POWER
6	289 295	Druckfeder
7	289 308	Abdeckung
8	289 319	Fenster
12	289 320	Tasten 6-fach
13	289 321	Tasten 6-fach
14	286 901	Schalter
17	284 318	Schalter (Power)
18	289 322	Fuß
19	289 302	Cinchbuchse 2-fach
20	286 897	REMOTE-Buchse
21	286 953	RC-Kabel
22	289 266	Netzbuchse
26	279 596	Netzkabel Europa
CD-Mechanik		
11	289 963	Mechanik
13	284 805	Antriebsrolle
14	284 806	Antriebsrad
15	284 807	Zahnrad
16	284 808	Laderad
17	284 809	Kurvenrad
17	289 712	Netzschalterplatte
24	284 813	Dämpferachse
25	284 814	Halter
28	284 815	Gummipuffer
29	284 315	Riemen
31	284 817	Feder V
32	284 818	Feder M
33	284 819	Motorplatte
34	283 709	Motor (LOAD)
35	283 736	Schalter
40	286 958	Pick-up
Elektronik		
D 101	226 501	Diode 1 N 4002
bis		
D 104	226 501	Diode 1 N 4002
D 105	283 714	Diode DZ 6,8
D 106	283 714	Diode DZ 6,8
D 107	282 174	Diode DZ 5,1 BM

Pos.	Art.-Nr.	Bezeichnung
D 108	223 906	Diode 1 N 4148
bis		
D 111	223 906	Diode 1 N 4148
IC 101	289 324	IC CXA 1081
IC 102	289 325	IC CXA 1082
IC 103	286 923	IC CXD 1167 Q
IC 104	289 326	IC DWP 305
IC 105	286 922	IC YM 3433
IC 106	289 327	IC AD 1861
IC 107	289 327	IC AD 1861
IC 108	282 749	IC NJM 4560 S
IC 109	236 299	IC RC 4558 D
IC 110	283 727	IC GD 7805
IC 111	283 142	IC MC 7905 CT
Q 101	283 436	Transistor KTA 966 A
Q 102	286 904	Transistor MPS A 06
bis		
Q 106	286 904	Transistor MPS A 06
Q 107	286 905	Transistor MPS A 56
bis		
Q 111	286 905	Transistor MPS A 56
Q 112	284 787	Transistor KTD 1302
Q 113	282 077	Transistor KTA 1015 Y
Q 114	284 787	Transistor KTD 1302
Q 115	284 787	Transistor KTD 1302
Q 116	282 076	Transistor KTC 1815 Y
bis		
Q 118	282 076	Transistor KTC 1815 Y
Q 119	282 077	Transistor KTA 1015 Y
Q 120	284 787	Transistor KTD 1302
Q 121	284 787	Transistor KTD 1302
Q 122	283 729	Transistor DTC 144 E
Q 123	283 729	Transistor DTC 144 E
L 101	284 800	Spule 10 UH
X-TAL	289 328	Quartz 16,9344 MHz
D 201	223 906	Diode 1 N 4148
bis		
D 203	223 906	Diode 1 N 4148
LCD	289 329	Display
	283 721	Lampe 9,6 V 120 mA
	283 712	Netztrafo

Änderungen vorbehalten! Subject to change! Sous réserve de modification!