

Service-Anleitung  
Service Manual  
Instructions de Service

## CD 3650



Technische Daten Meßwerte = typische Werte	Technical data Measured values = typical values	Caractéristiques techniques Valeurs mesurées = valeurs typiques	CD 3650
Frequenzbereich	Frequency response	Courbe de réponse	10-20 000 Hz
Geräuschspannungsabstand	Signal to noise ratio	Rapport signal/bruit	95 dB
Dynamikbereich	Dynamic range	Dynamique	92 dB
Übersprechdämpfung (1 kHz)	Crosstalk (1 kHz)	Diaphonie (1 kHz)	90 dB
Klirrfaktor (1 kHz)	Harmonic distortion (1 kHz)	Distorsion harmonique (1 kHz)	0,05 %
Gleichlaufschwankungen	Wow and flutter	Fluctuations	± 0,001 %
Ausgangsspannung	Output voltage	Tension de sortie	2 V
Max. programmierbare Musiktitel	Max. music title programming	Titres de musique au max. programmés	20
D/A Wandler	D/A Converter	D/A Convertisseur	16 Bit
Abtastfrequenz	Sampling frequency	Fréquence de pick-up	88,2 kHz
Abtastsystem	Pick up	Pick-up	3-Strahl-Laser 3-beam optical pick up
Betriebsspannung	Operating voltage	Tension de service	16 V ~
Stromaufnahme	Current input	Consommation	800 mA

## Abgleichanleitung CD 3650

Bei Neuabgleich Regler VR 1–VR 3 in Mittenstellung.

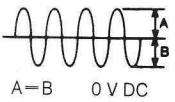
Signalquelle	Einstellung Gerät	Meßgeräteanschluß	Abgleichposition	Abgleichbemerkung
<b>1) PLL</b>				
	Stop	1. Kurzschluß zwischen EFM u. G an Steckerleiste TP 2 2. Frequenzzähler an PCK	L 2	4,321 MHz
		3. Kurzschluß trennen		
<b>2) Tracking off set</b>				
	Stop	1. Kurzschluß zwischen TO u. G an Steckerleiste TP 2. 2. Osci an TA von TP 1	VR 3	100 mV DC
		3. Kurzschluß trennen		
<b>3) EF Balance</b>				
Testplatte Phillips 5 A	Play	1. Osci an TE von Steckerleiste TP 3 2. Kurzschluß zwischen TG u. G von TP 3	VR 2	
		3. Kurzschluß trennen		
<b>4) Focus gain</b>				
	Play Titel Nr. 1	Milivoltmeter an FA von Steckerleiste TP 1	VR 1	220 mV AC
Kontrolle EFM Signal an Brücke „EFM in“ ca. 3 VSS				
Alle Spannungen gegen Masse gemessen				

### Vorsicht

Dieser Disc-Spieler arbeitet mit unsichtbarem Laserlicht. Bei geöffnetem Gerät tritt unterhalb des Plattenhalterungsarmes Laserstrahlung aus.

Nicht in den Strahl blicken und nicht dem Strahl aussetzen!  
Laserstrahlung im Innern des Gerätes. Öffnen des Gehäuses zur Vermeidung von Strahlungsschäden nur durch qualifiziertes Fachpersonal zulässig.

Informationsetikett auf Geräterückseite

Warnetikett innen am Plattenschacht

**CLASS 1  
LASER PRODUCT  
LASER KLASSE 1  
APPAREIL A LASER  
DE CLASSE 1**

**VORSICHT!  
UNSICHTBARE LASERSTRAHLUNG TRITT  
AUS, WENN DECKEL GEÖFFNET IST!  
NICHT DEM STRAHL AUSSETZEN!  
LASER KLASSE 1**

**CAUTION –  
INVISIBLE LASER RADIATION WHEN  
OPEN. AVOID EXPOSURE TO BEAM  
CLASS 1 LASER PRODUCT.**

## Tuning instruction for CD 3650

At Newtuning controller VR 1–VR 3 in position middle.

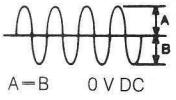
Signal source	Equipment setting	Connection at measuring devices	Item to be tuned	Tuning remarks
<b>1) PLL</b>				
	Stop	1. Short circuit between EFM and G to plug plate TP 2 2. Frequency counter to PCK	L 2	4,321 MHz
		3. Disconnect short circuit		
<b>2) Tracking off set</b>				
	Stop	1. Short circuit between TO and G to plug plate TP 2. 2. Oscillator to TA of TP 1	VR 3	100 mV DC
		3. Disconnect short circuit		
<b>3) EF balance</b>				
Phillips test disc 5 A	Play	1. Oscillator to TE of plug plate TP 3 2. Short circuit between TG and G of TP 3	VR 2	
		3. Disconnect short circuit		
<b>4) Focus gain</b>				
	Play Titel No. 1	Milivoltmeter to FA of plug plate TP 1	VR 1	220 mV AL
Control EFM signal to bridge „EFM in“ approx. 3 VSS				
All voltages are measured against earth.				



braun  
brown  
rot  
red  
orang  
orange

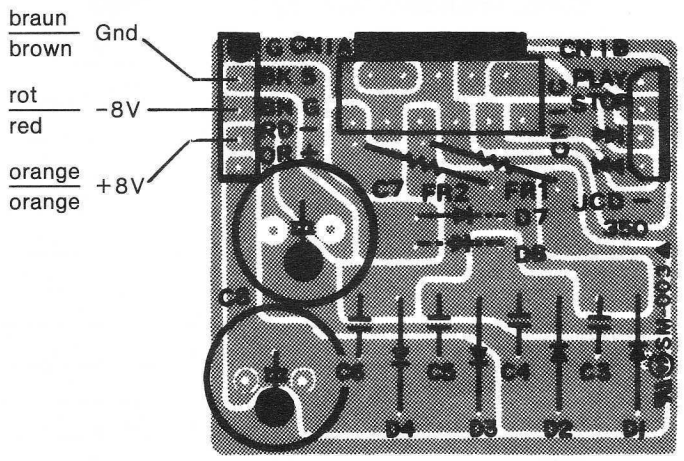
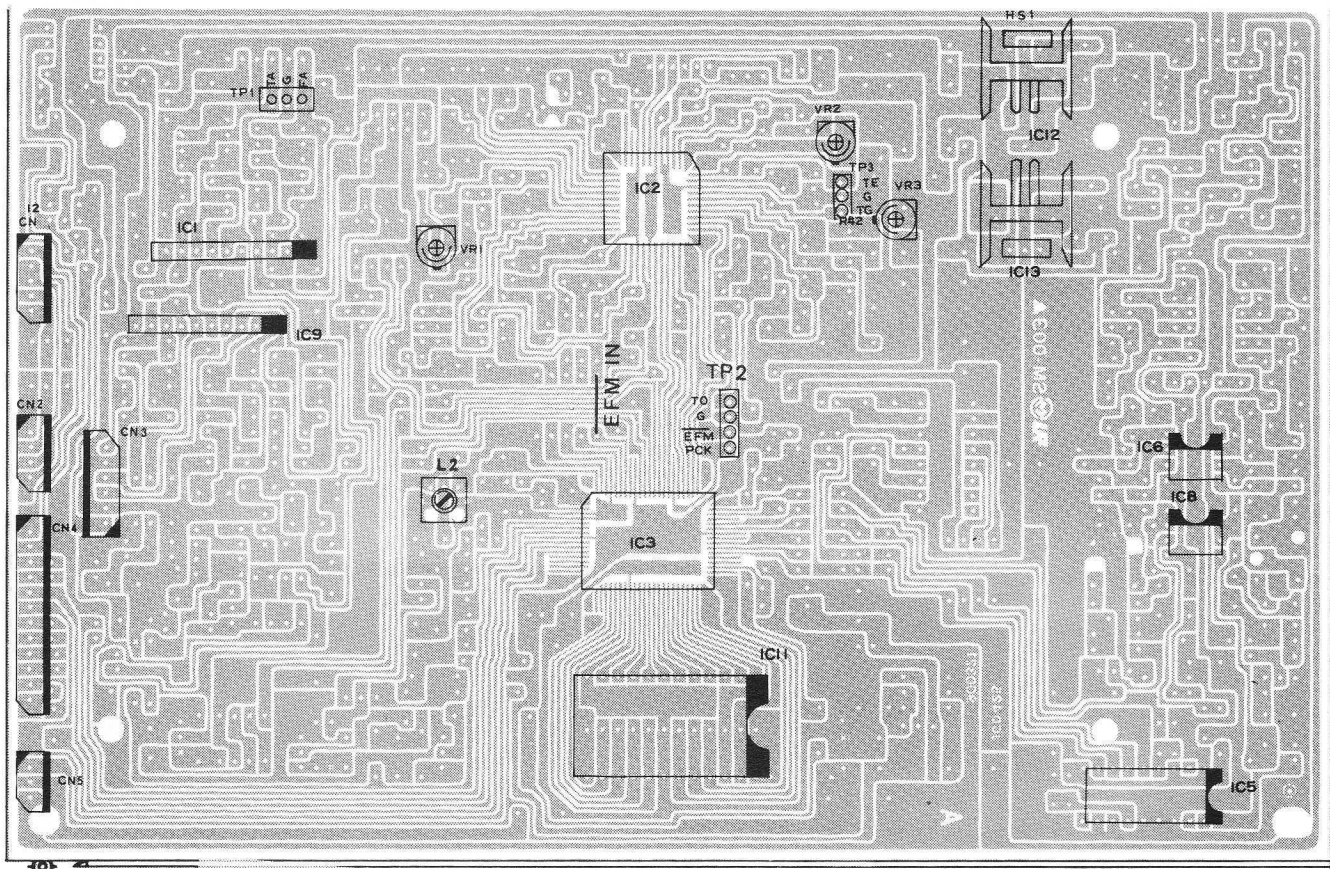

Externe Spannungsversorgung +8V und -8V sowie Gnd auf der Leiterseite anlöten.  
 Please solve external voltage supply +8V and -8V as well as Gnd on wiring-side.



IC11 GM76C 28

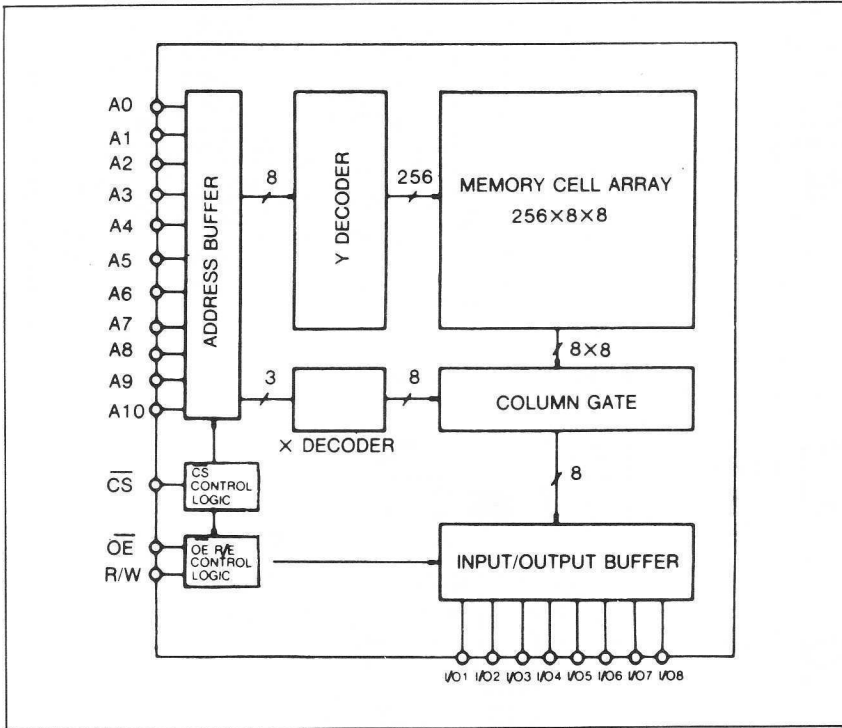

IC3 LC7860N

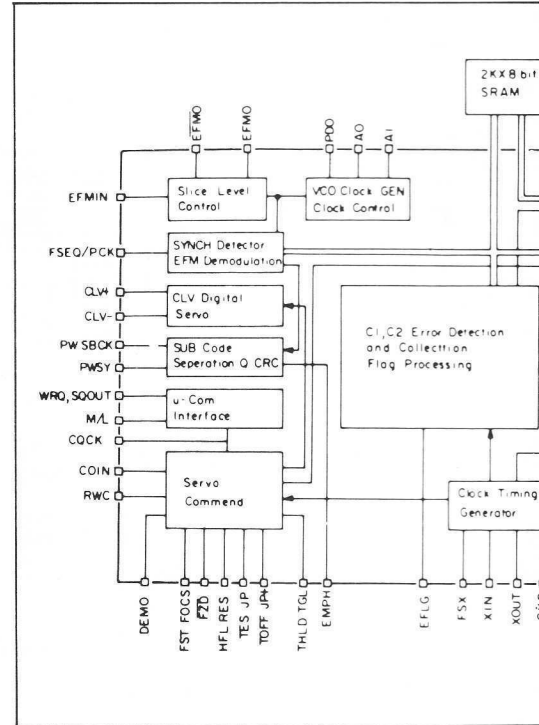

IC2 LA9200 NM

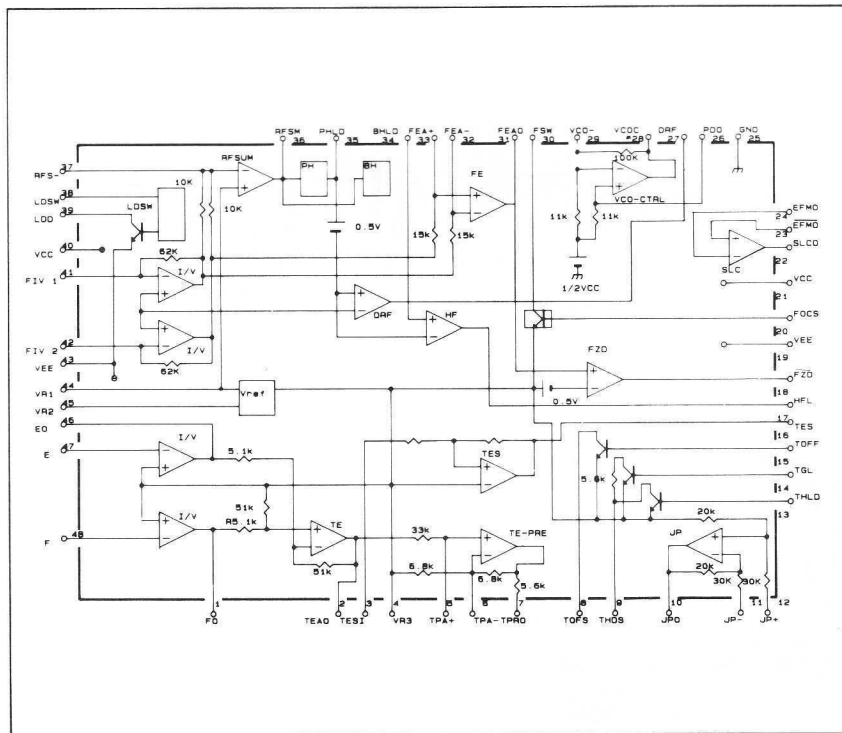

IC12 GL7805

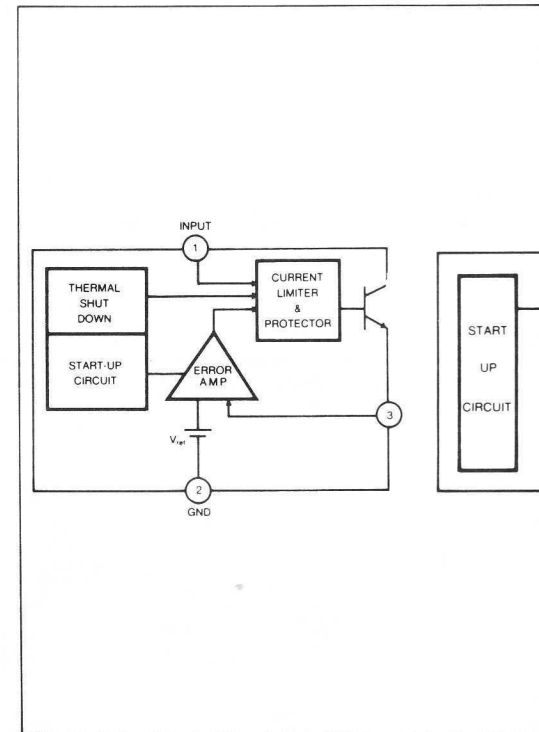

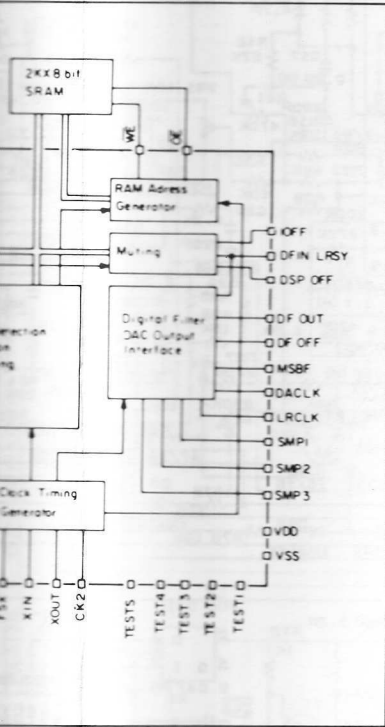

IC1,9

IC5, LC7881

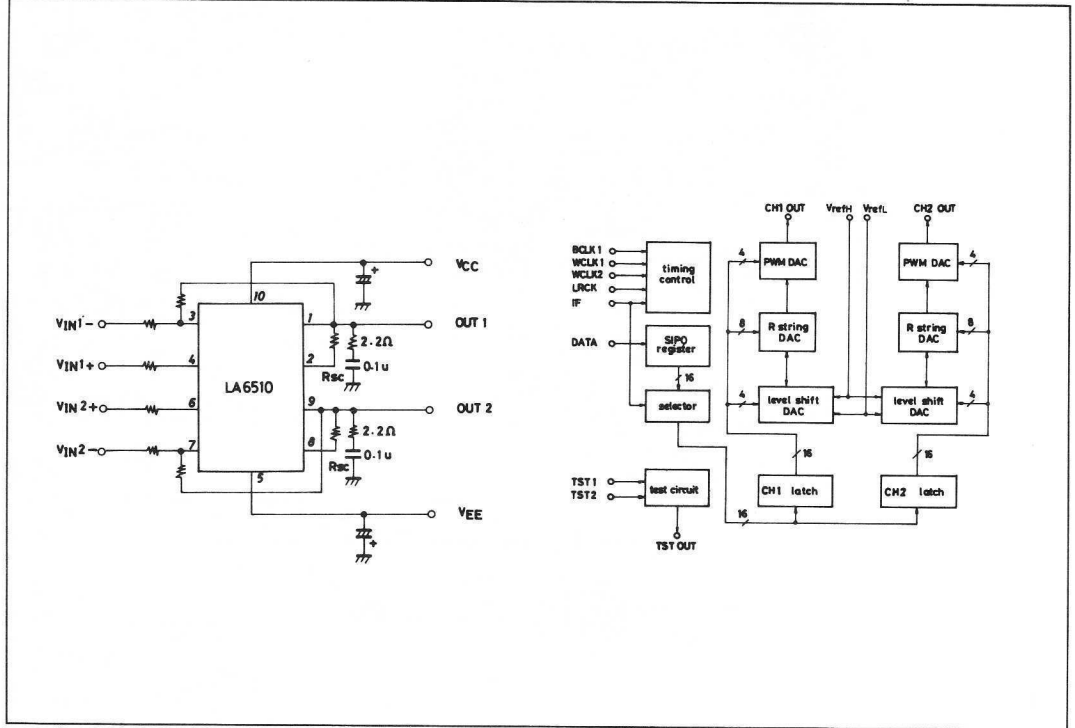

IC13 GL7905

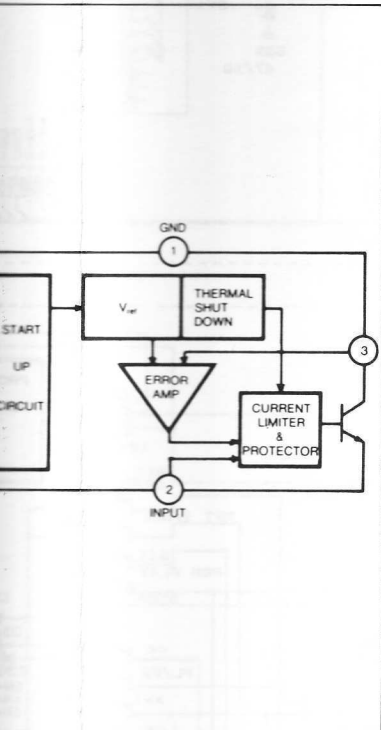

IC6, 8, 10 BA4558, BA4560

IC90 CXP 5086-535Q

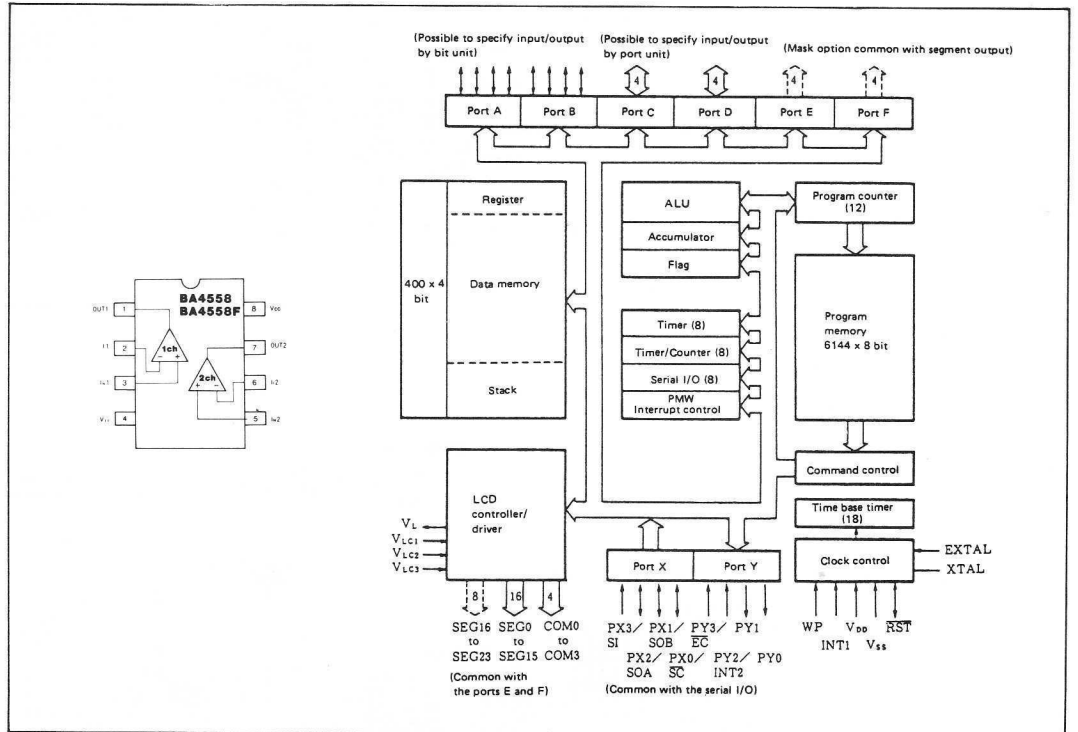

Schematic Diagram

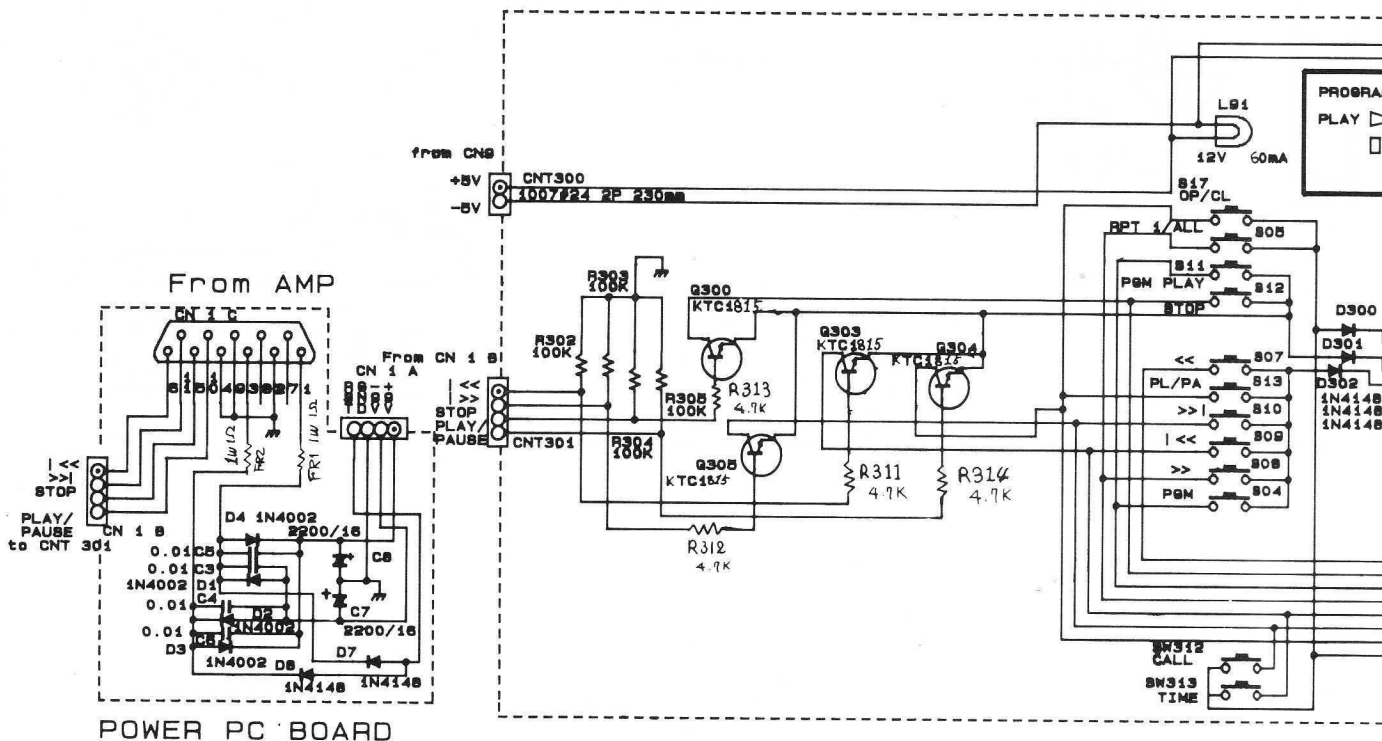
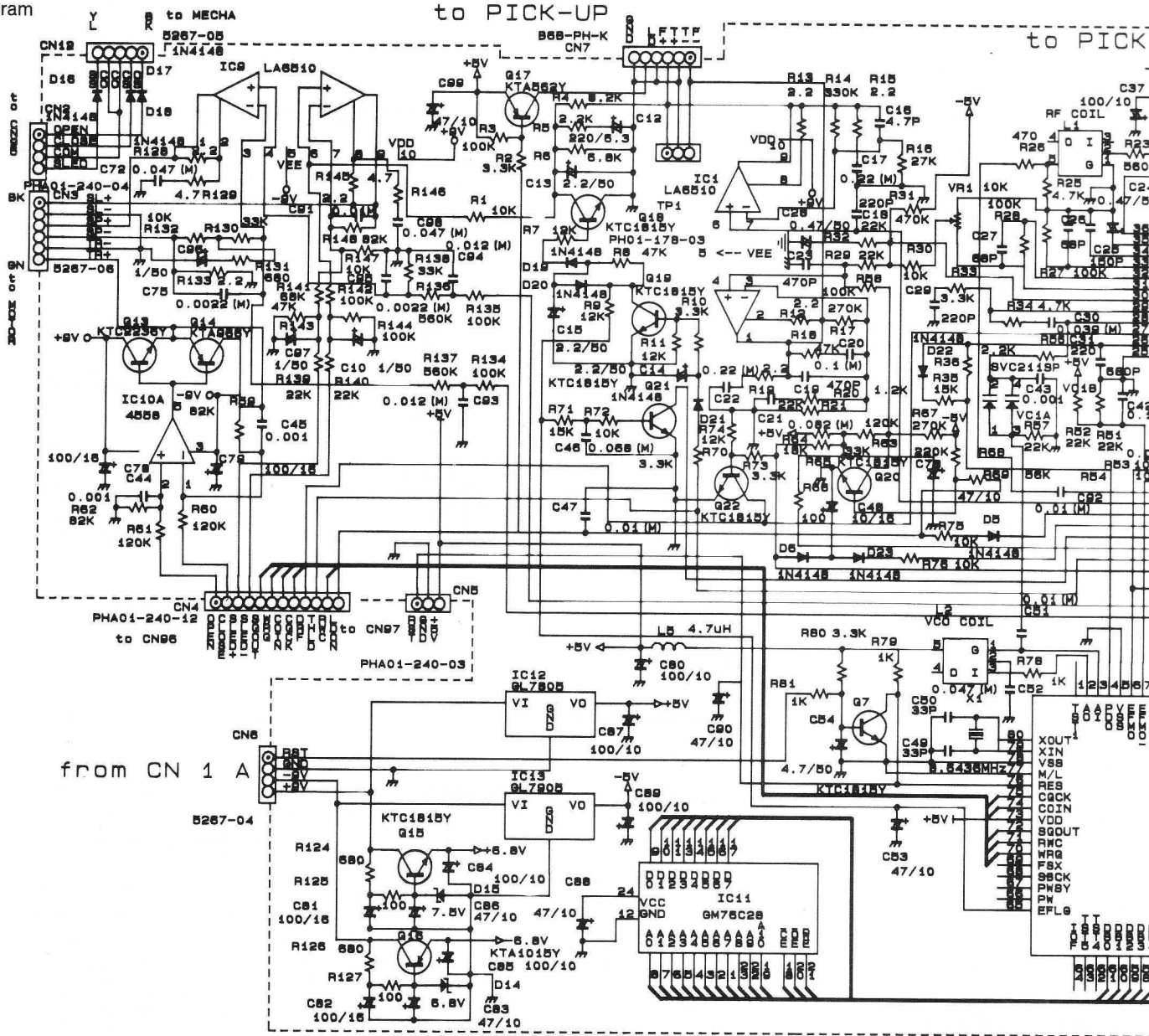

RCA PC BOARD

to PICK-UP

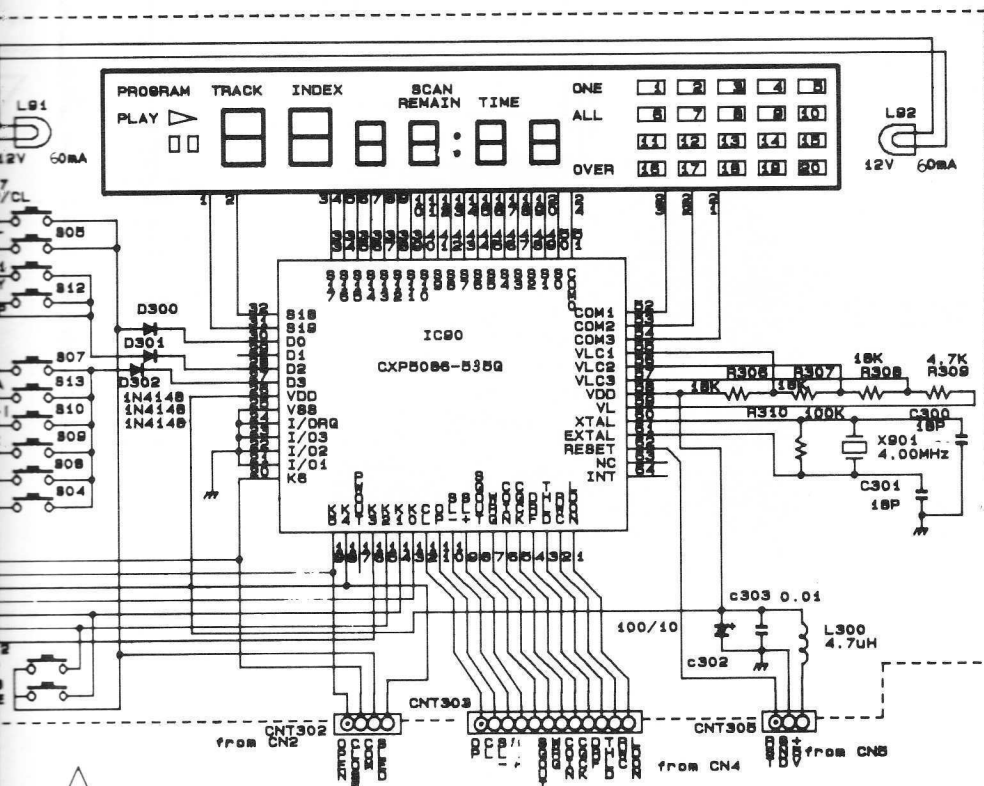
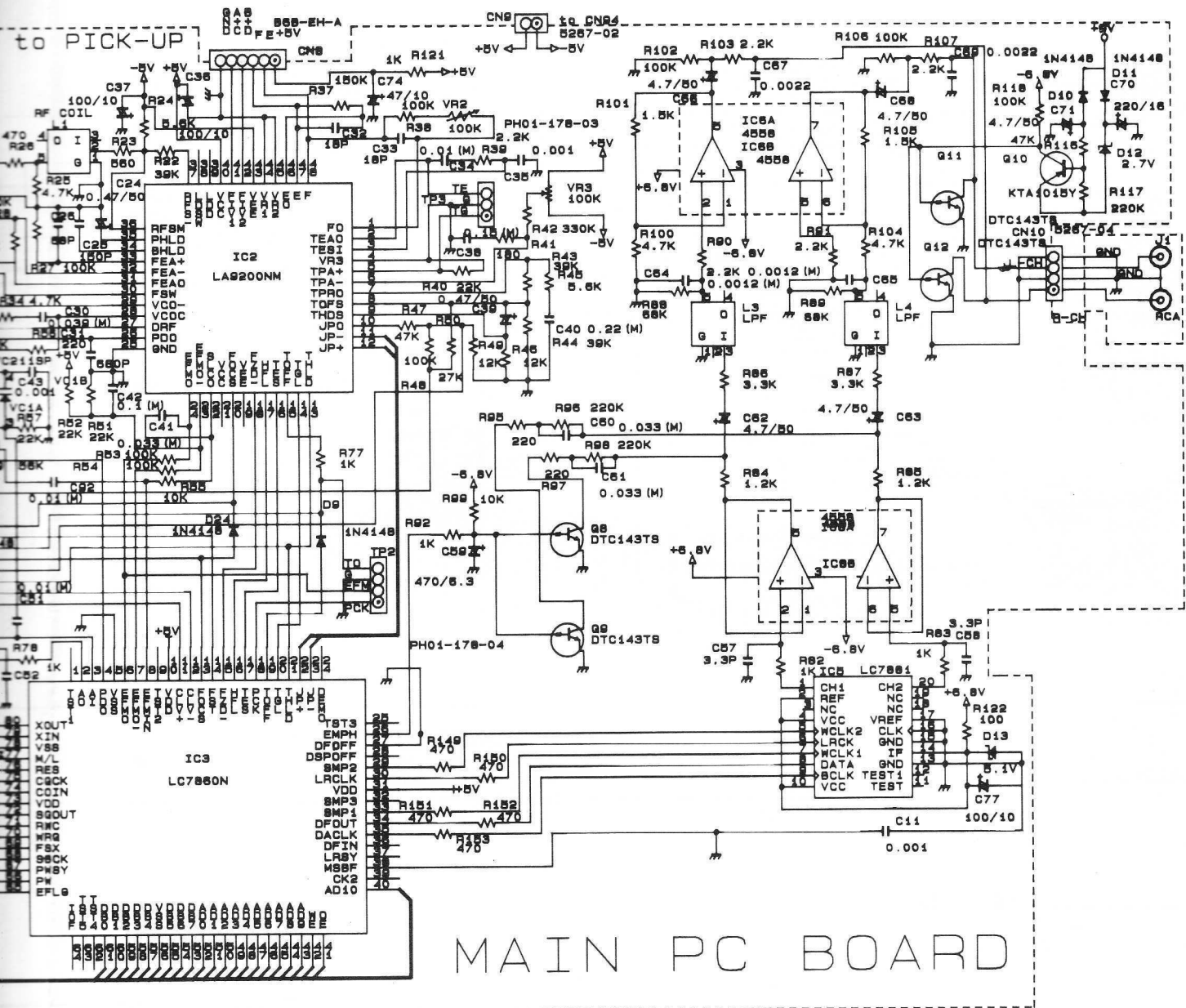

A



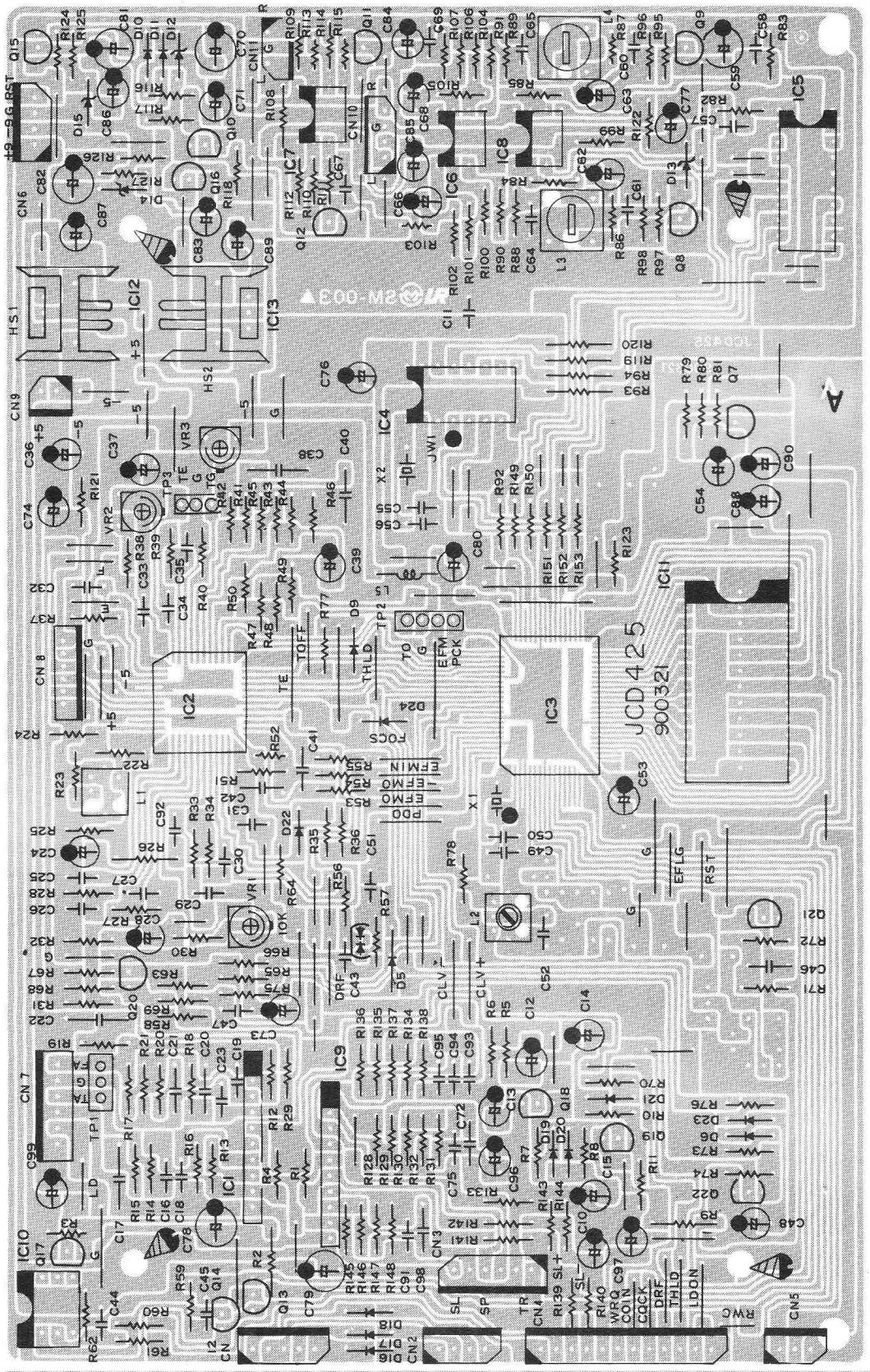

Powerplatte  
Power P.C.B.

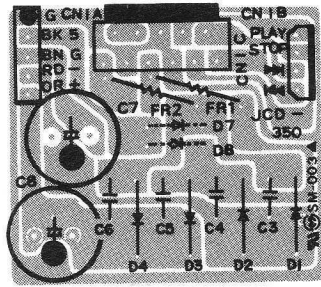

Displayplatte  
Display P.C.B.

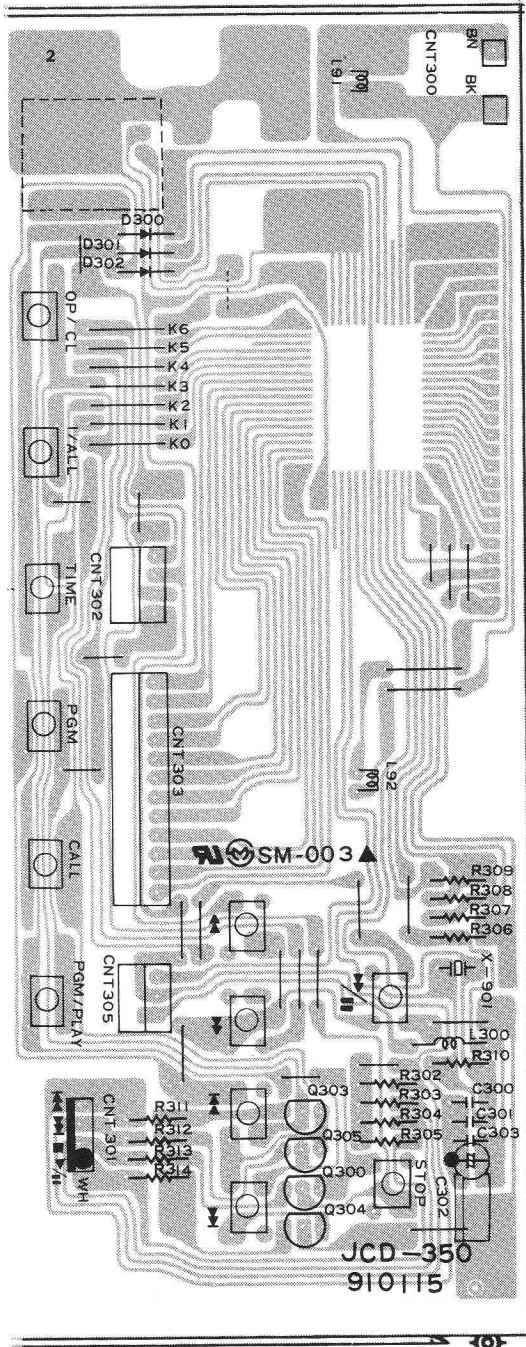



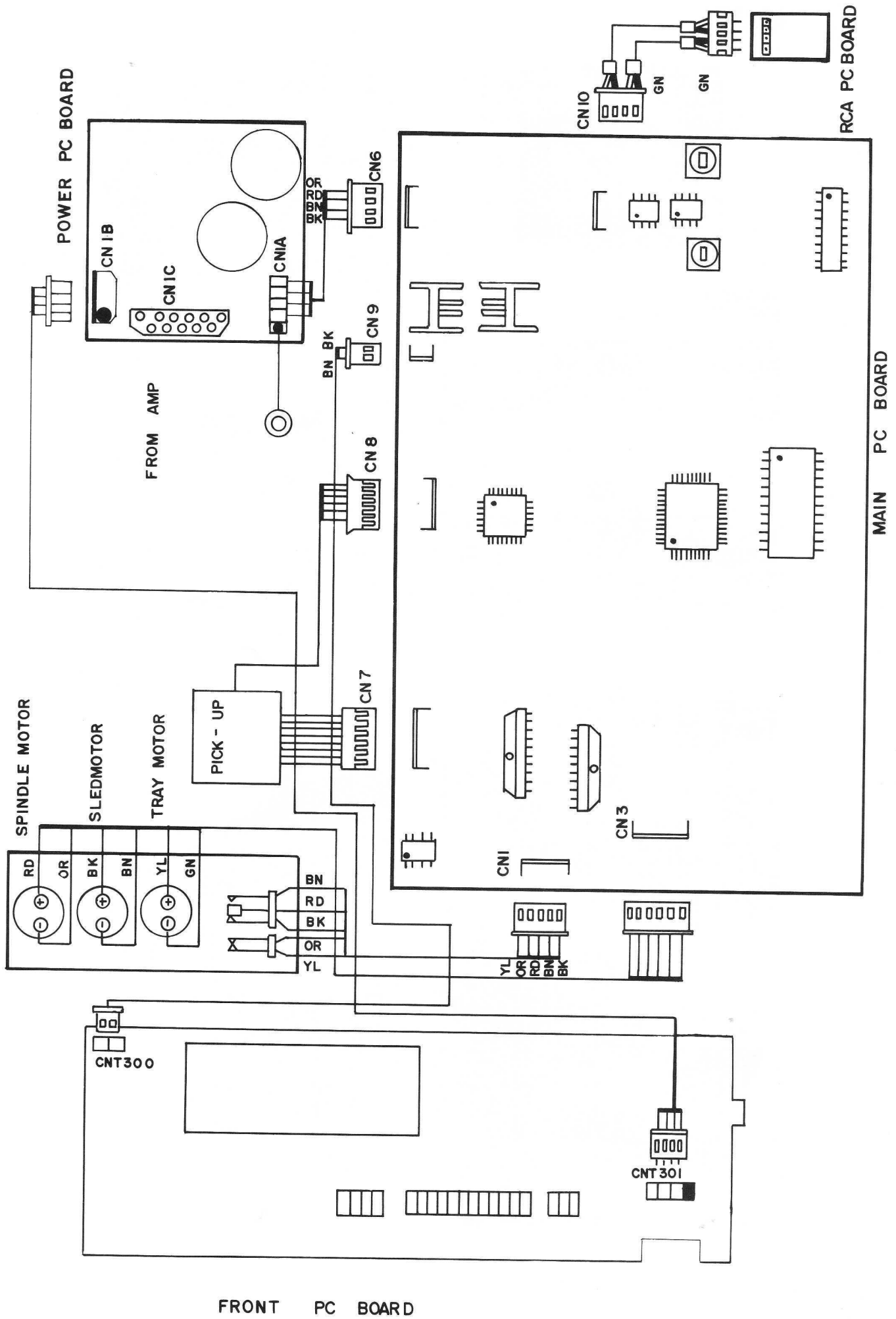

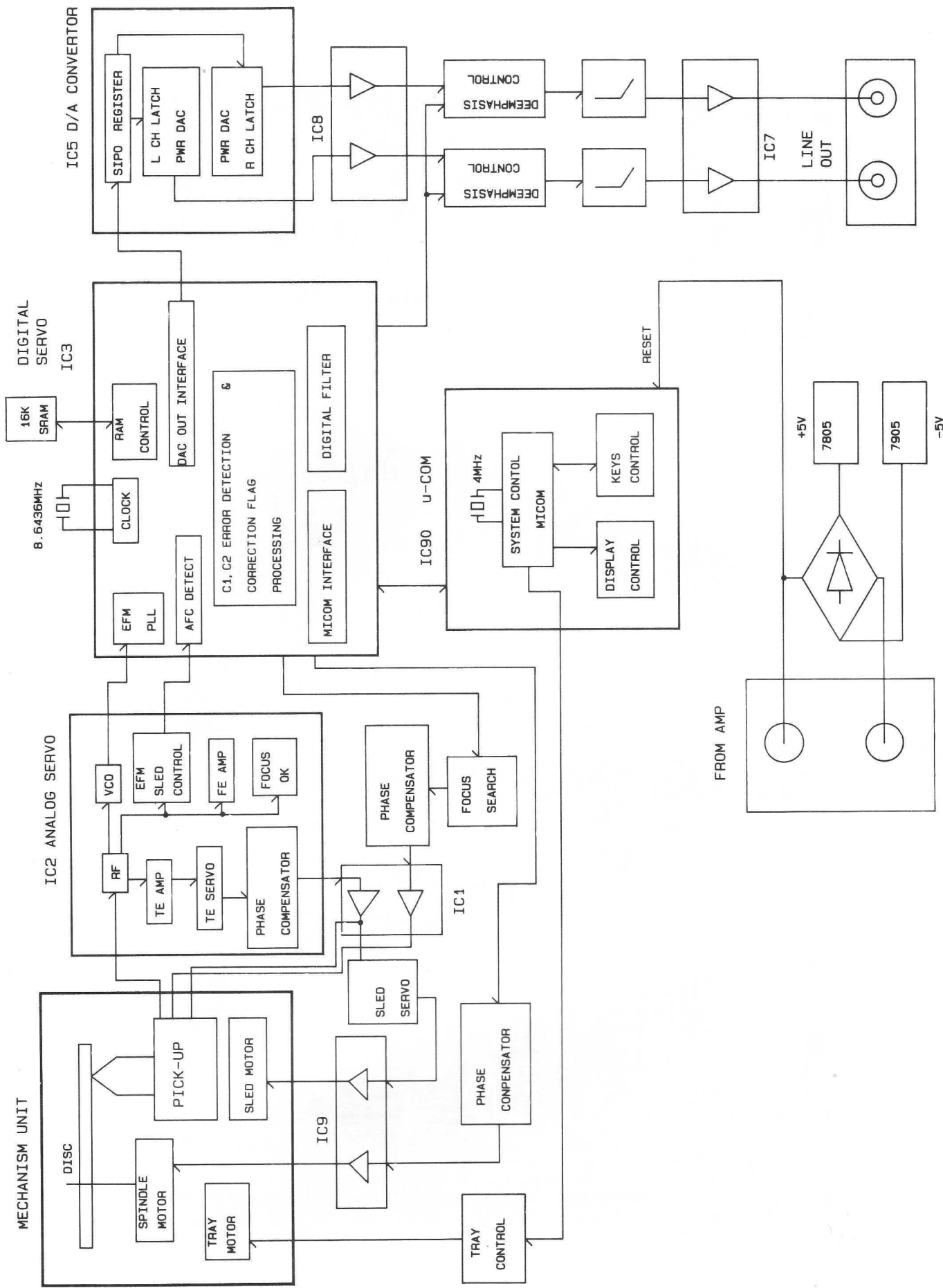

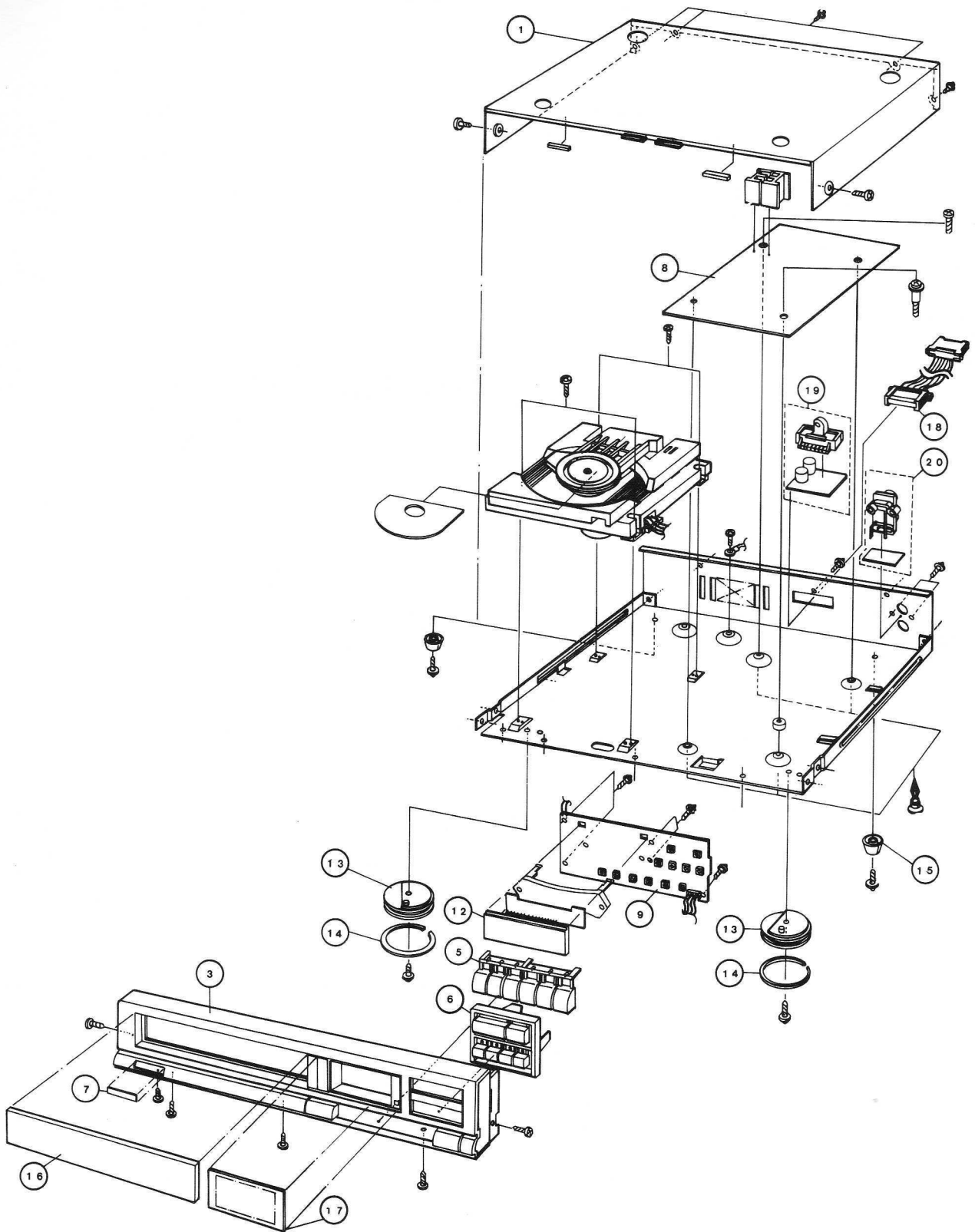

Ersatzteile · Replacement parts · Pièces détachées · CD 3650

Pos.	Art.-Nr.	Bezeichnung
1	287 766	Gehäuseblech
3	287 767	Frontblende
5	287 769	Taste 6-fach
6	287 770	Tastenset
7	287 771	Taste Power
12	287 774	Display
13	287 775	Fuß
14	287 776	Zierring
15	287 777	Fuß
16	287 778	Abdeckung
17	287 779	Fenster
18	287 780	Anschlußkabel/11-polig
19	287 781	Anschlußbuchse
20	287 782	Cinchbuchse
	287 768	<b>CD-Mechanik CD 3650</b>
3	287 688	Schublade
4	287 783	Gummitülle
5	287 784	Motor loading
6	287 785	Antriebsrolle
8	287 786	Riemenrad
9	287 787	Riemen
10	287 788	Zahnrad
25	287 794	Riemenrad
28	287 789	Motor
29	287 790	Riemen 41/1,2
30	287 791	Motor Spindel
31	287 795	Plattenteller
32	289 495	Schalter
33	289 494	Schalter
34	287 792	Zahnrad
42	287 793	Pick-up
8		<b>Grundplatte</b>
Q 17	270 183	Transistor 2 SA 562 Y
Q 14	283 436	Transistor KTA 966 A
Q 13	283 437	Transistor KTC 2236 A
Q 10	282 077	Transistor KTA 1015 Y
Q 16	282 077	Transistor KTA 1015 Y
Q 7	282 076	Transistor KTC 1815 Y
Q 15	282 076	Transistor KTC 1815 Y
Q 18	282 076	Transistor KTC 1815 Y
Q 19	282 076	Transistor KTC 1815 Y
Q 20	282 076	Transistor KTC 1815 Y
Q 8	286 577	Transistor DTC 143
Q 9	286 577	Transistor DTC 143
Q 11	286 577	Transistor DTC 143
Q 12	286 577	Transistor DTC 143

Pos.	Art.-Nr.	Bezeichnung
D 5	223 906	Diode 1N 4148
D 6	223 906	Diode 1N 4148
D 10	223 906	Diode 1N 4148
D 11	223 906	Diode 1N 4148
D 12	280 915	Diode ZPD 2,7/2 %
D 13	282 174	Diode DZ 5,1 BM
D 14	283 714	Diode DZ 6,8
D 15	283 553	Diode DZ 7,5
D 16	223 906	Diode 1N 4148
bis		
D 24	223 906	Diode 1N 4148
VC 1	275 158	Diode SVC 211 SP
IC 11	287 796	IC GM 76028
IC 3	286 814	IC LC 7860 N
IC 2	286 811	IC LA 9200 NM
IC 4	283 149	IC LC 7881 M
IC 1	287 797	IC LA 6510
IC 9	287 797	IC LA 6510
IC 10	283 725	IC BA 4558
IC 6	287 798	IC BA 4560
IC 8	287 798	IC BA 4560
IC 12	284 290	IC GL 7805
IC 13	283 142	IC MC 7905 CT
L 1	287 799	Spule
L 2	287 800	Spule
L 5	287 801	Spule 4,7 UH
L 3	287 802	Spule low pass
L 4	287 802	Spule low pass
X 1	281 500	Quarz 8,6436 MHz
9		<b>Display/Tastenplatte</b>
Q 300	282 076	Transistor KTC 1815 Y
Q 303	282 076	Transistor KTC 1815 Y
Q 304	282 076	Transistor KTC 1815 Y
D 300	223 906	Diode 1N 4148
D 301	223 906	Diode 1N 4148
D 302	223 906	Diode 1N 4148
IC 90	287 803	IC CXP 5086 H
	287 774	Display
L 91	287 804	Lampe 80 MA/12 V
L 92	287 804	Lampe 80 MA/12 V
L 300	287 801	Spule 4,7 UH
	287 805	Schalter
X 901	281 411	Quarz 4 MHz
	287 806	Kopfhörerbuchse
D 1	226 501	Diode 1N 4002
bis		
D 4	226 501	Diode 1N 4002

Änderungen vorbehalten! Subject to change! Sous réserve de modification!

