

PA 5060 PA 5030

Service-Anleitung Service Manual Instructions de Service

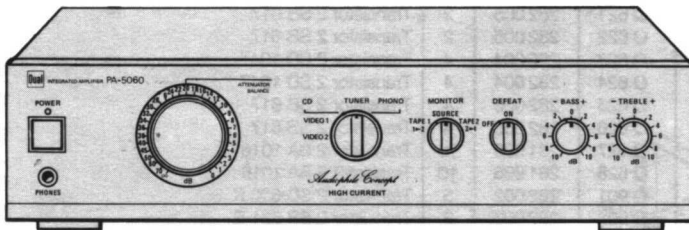

Technische Daten (typische Werte)	Technical data (typical value)	Caractéristiques techniques (valeur caractéristique)	PA 5060	PA 5030
Dauer-Ausgangsleistung (8 Ohm, beide Kanäle angesteuert) IEC 20–20000 Hz Klirrfaktor 0,03 % DIN 1 kHz Klirrfaktor 1 % Impuls-Ausgangsleistung (1 kHz Bursts) an 8 Ohm an 4 Ohm an 2 Ohm	Continuous power output (8 ohms to both channels) IEC 20–20000 Hz Harmonic distortion 0.03 % DIN 1 kHz Harmonic distortion 1 % Peak puls power (1 kHz bursts) 8 ohms 4 ohms 2 ohms	Puissance efficace (8 ohms) IEC 20–20000 Hz Taux de distorsion 0,03 % DIN 1 kHz Taux de distorsion 1 % Puissance de l'impulsion de crête (1 kHz bursts) 8 ohms 4 ohms 2 ohms	2× 60 W 2× 70 W	2×30 W 2×35 W
Klirrfaktor Nennleistung – 6 dB, 1 kHz	Harmonic distortion Continuous power – 6 dB, 1 kHz	Taux de distorsion Puissance efficace – 6 dB, 1 kHz	0,01 %	0,015 %
Intermodulation-Verzerrungen 60 Hz – 7 kHz 4:1	Intermodulation distortion 60 Hz – 7 kHz 4:1	Distorsion d'intermodulation 60 Hz – 7 kHz 4:1	0,02 %	0,03 %
Leistungsbandbreite – 3 dB	Power band width – 3 dB	Bande passante – 3 dB	6 Hz – 95 kHz	6 Hz – 90 kHz
Übertragungsbereich Tuner, CD, Tape, Video, Phono (RIAA)	Frequenz response Tuner, CD, Tape, Video, Phono (RIAA)	Bande passante Tuner, CD, Tape, Video, Phono (RIAA)	20 Hz – 20 kHz ± 0,4 dB 20 Hz – 20 kHz ± 1 dB	
Dämpfungsfaktor (40 Hz – 12,5 kHz, 8 Ohm)	Damping factor (40 Hz – 12,5 kHz, 8 ohms)	Facteur d'amortissement (40 Hz – 12,5 kHz, 8 ohms)	> 80	
Eingangsempfindlichkeit/Impedanz Phono MM (Cinch, vergoldet) Phono MC (Cinch, vergoldet) Tuner, CD, Tape Monitor 1–2, Video 1–2 (Cinch)	Inputs Phono MM Phono MC Tuner, CD, Tape, Monitor 1–2, Video 1–2	Entrées Phono MM Phono MC Tuner, CD, Tape Monitor 1–2, Video 1–2	2,5 mV, 47 kOhm 0,2 mV, 100 Ohm 200 mV, 56 kOhm	
Ausgänge 4 mm Buchsen für zwei Lautsprecher Koaxialbuchse 1/4 inch für Kopfhörer Line Ausgänge für Tape 1/Tape 2/ Video 1 (Cinch)	Outputs 4 mm jack for 1 set of speakers 1 coaxial jack 1/4 inch for headphone Line outputs Tape 1, Tape 2, Video 1	Sorties Prise coaxiale pour une paire de hauts-parleurs 1 prise coaxiale de 1/4 inch le raccordement du casque-ecouter Sorties Line sur la price Tape 1, Tape 2, Video 1	8 Ohm 8–600 Ohm	
Geräuschspannungsabstand Nennleistung Kurve A Phono Tuner, CD, Tape, Video	Signal to noise ratio Continuous power Phono Tuner, CD, Tape, Video	Rapport signal/bruit Puissance efficace Phono Tuner, CD, Tape, Video	78 dB 100 dB	
Übersprechdämpfung , 1 kHz zwischen den Kanälen zwischen den Eingängen	Cross-talk attenuation , 1 kHz between the channels between the inputs	Rapport de diaphonie , 1 kHz entre les canaux entre les entrées	70 dB 80 dB	
Netzspannung/Frequenz	Mains voltage	Tensions secteur	Europe 220 V 50 Hz UK 240 V 50 Hz USA/Kanada 120 V 60 Hz	

Ersatzteile · Replacement parts · Pièces détachées · PA 5060

Pos.	Art.-Nr.	Stck	Bezeichnung
1	282 017	1	Frontblende
2	281 972	2	Drehknopf (Baß, Treble)
3	281 973	1	Drehknopf (Defeat, Monitor)
4	281 974	1	Drehknopf (Eingangswahlschalter)
5	281 975	1	Drehknopf (Attenuator)
6	281 976	1	Drehknopf (Balance)
7	281 977	1	Platte
8	281 978	1	Taste (Power)
10	281 979	1	Distanzstück
11	281 980	1	Rahmen (Power)
16	282 022	1	Klangstellerplatte
S 501	282 020	1	Schalter
IC 502	279 914	1	IC NE 5532 N/RC 5532 N
VR 502	282 011	2	Steller 20 K
VR 503	282 011	1	Steller 20 K
17	281 982	1	Schalter (Eingangswahlschalter)
17	281 983	1	Schalter (Monitor)
18	281 984	1	Volumenplatte
VR 501	282 010	1	Steller 100 K
19	281 985	1	Kopfhörerplatte
20	281 986	1	Netzschalterplatte
S 1	281 999	1	Schalter
23	281 987	1	Fuß
26	282 023	1	Grundplatte
D 1	281 997	1	LED LTL-2201 A rot
D 601	223 906	8	Diode 1 N 4148
D 604	223 906	8	Diode 1 N 4148
D 605	223 906	8	Diode 1 N 4148
D 606	223 906	8	Diode 1 N 4148
D 901	282 019	1	Diode KBPC-802
D 903	281 996	2	Diode UZ-18 B
D 904	281 996	2	Diode UZ-18 B
D 905	223 906	8	Diode 1 N 4148
D 905	282 021	1	Diode 1 N 4003
D 906	223 906	8	Diode 1 N 4148
D 907	223 906	8	Diode 1 N 4148
L 601	282 013	2	Spule
L 602	282 013	2	Spule

Pos.	Art.-Nr.	Stck	Bezeichnung
Q 601	281 998	10	Transistor 2 SA 1016
Q 606	281 998	10	Transistor 2 SA 1016
Q 607	282 000	2	Transistor 2 SA 2910
Q 608	282 000	2	Transistor 2 SA 2910
Q 609	281 998	10	Transistor 2 SA 1016
Q 610	281 998	10	Transistor 2 SA 1016
Q 611	282 001	2	Transistor 2 SA 1208
Q 612	282 001	2	Transistor 2 SA 1208
Q 613	282 002	5	Transistor 2 SD 600 K
Q 616	282 002	5	Transistor 2 SD 600 K
Q 617	282 003	2	Transistor 2 SB 631 B
Q 618	282 003	3	Transistor 2 SB 631 B
Q 619	282 004	2	Transistor 2 SD 1047
Q 620	282 004	2	Transistor 2 SD 1047
Q 621	282 005	2	Transistor 2 SB 817
Q 622	282 005	2	Transistor 2 SB 817
Q 623	282 004	4	Transistor 2 SD 1047
Q 624	282 004	4	Transistor 2 SD 1047
Q 625	282 005	4	Transistor 2 SB 817
Q 626	282 005	4	Transistor 2 SB 817
Q 627	281 998	10	Transistor 2 SA 1016
Q 628	281 998	10	Transistor 2 SA 1016
Q 901	282 002	5	Transistor 2 SD 600 K
Q 902	282 003	3	Transistor 2 SB 631 B
IC 901	282 007	1	IC UPC 1237 H
RY 901	282 009	1	Relay AP 24D2
TH 901	282 008	1	Heißleiter TD5C350D
VR 601	282 012	2	Steller 2,2 K
VR 602	282 012	2	Steller 2,2 K
28	282 018	1	Netztrafo
29	281 990	1	Anschlußplatte
S 401	282 014	1	Schalter
S 402	282 015	1	Schalter
S 403	282 016	1	Schalter
IC 401	282 006	1	IC NJM 2041
32	281 991	1	Anschlußklemme
33	243 750	1	Netzkabel Europa
34	281 992	1	Anschlußbuchse AC
36	281 993	1	Spannungswähler
37	281 994	1	Gehäuseblech
99	281 422	1	Bedienungs-Anleitung PA 5060

Änderungen vorbehalten! Subject to change! Sous réserve de modification!

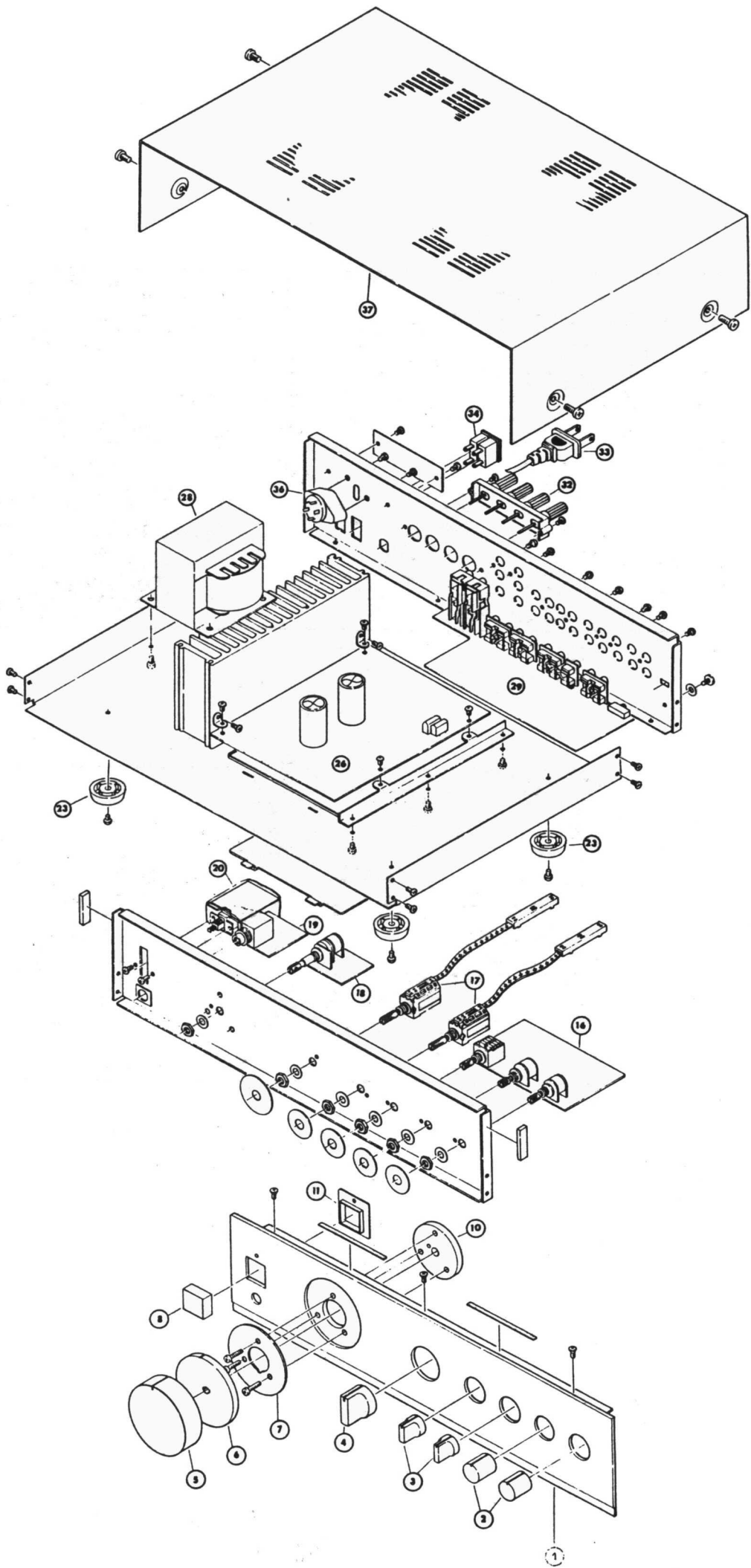

Ersatzteile · Replacement parts · Pièces détachées · PA 5030

Pos.	Art.-Nr.	Stck	Bezeichnung
1	281 971	1	Frontblende
2	281 972	2	Drehknopf (Baß, Treble)
3	281 973	1	Drehknopf (Monitor)
4	281 974	1	Drehknopf Eingangswahlschalter
5	281 975	1	Drehknopf (Attenuator)
6	281 976	1	Drehknopf (Balance)
7	281 977	1	Platte
8	281 978	1	Taste (Power)
10	281 979	1	Distanzstück
11	281 980	1	Rahmen (Power)
16	281 981	1	Klangstellerplatte
IC 502	279 914	1	IC NE 5532 N/RC 5532 N
VR 502	282 011	2	Steller 20 K
VR 503	282 011	1	Steller 20 K
17	281 982	1	Schalter (Eingangswahlschalter)
17	281 983	1	Schalter (Monitor)
18	281 984	1	Volumeplatte
VR 501	282 010	1	Steller 100 K
19	281 985	1	Kopfhörerplatte
20	281 986	1	Netzschalterplatte
S 1	281 999	1	Schalter
23	281 987	1	Fuß
26	281 988	1	Grundplatte
D 1	281 997	1	LED LTL-2201 A rot
D 601	223 906	8	Diode 1 N 4148
D 604	223 906	8	Diode 1 N 4148
D 605	223 906	8	Diode 1 N 4148
D 606	223 906	8	Diode 1 N 4148
D 901	281 995	1	Gleichrichter KBPC-602
D 903	281 996	2	Diode UZ-18 B
D 904	281 996	2	Diode UZ-18 B
D 905	223 906	8	Diode 1 N 4148
D 906	223 906	8	Diode 1 N 4148
D 907	223 906	8	Diode 1 N 4148
L 601	282 013	2	Spule
L 602	282 013	2	Spule

Pos.	Art.-Nr.	Stck	Bezeichnung
Q 601	281 998	10	Transistor 2 SA 1016
Q 606	281 998	10	Transistor 2 SA 1016
Q 607	282 000	2	Transistor 2 SA 2910
Q 608	282 000	2	Transistor 2 SA 2910
Q 609	281 998	10	Transistor 2 SA 1016
Q 610	281 998	10	Transistor 2 SA 1016
Q 611	282 001	2	Transistor 2 SA 1208
Q 612	282 001	2	Transistor 2 SA 1208
Q 613	282 002	5	Transistor 2 SD 600 K
Q 616	282 002	5	Transistor 2 SD 600 K
Q 617	282 003	2	Transistor 2 SB 631 B
Q 618	282 003	3	Transistor 2 SB 631 B
Q 619	282 004	2	Transistor 2 SD 1047
Q 620	282 004	2	Transistor 2 SD 1047
Q 621	282 005	2	Transistor 2 SB 817
Q 622	282 005	2	Transistor 2 SB 817
Q 627	281 998	10	Transistor 2 SA 1016
Q 628	281 998	10	Transistor 2 SA 1016
Q 901	282 002	5	Transistor 2 SD 600 K
Q 902	282 003	3	Transistor 2 SB 631 B
IC 901	282 007	1	IC UPC 1237 H
RY 901	282 009	1	Relay AP 24D2
TH 901	282 008	1	Heißleiter TD5C350D
VR 601	282 012	2	Steller 2,2 K
VR 602	282 012	2	Steller 2,2 K
28	281 989	1	Netztrafo
29	281 990	1	Anschlußplatte
S 401	282 014	1	Schalter
S 402	282 015	1	Schalter
S 403	282 016	1	Schalter
IC 401	282 006	1	IC NJM 2041
32	281 991	1	Anschlußklemme
33	243 750	1	Netzkabel Europa
34	281 992	1	Anschlußbuchse AC
36	281 993	1	Spannungswähler
37	281 994	1	Gehäuseblech
99	281 421	1	Bedienungs-Anleitung PA 5030

Änderungen vorbehalten! Subject to change! Sous réserve de modification!

	Ⓓ Zeichenerklärung	ⒼⒷ Legend	Ⓕ Légende	Ⓔ Leyenda	Ⓘ Leggèda
—	Ein	On	Marche	Encendido	Acceso
○	Aus	Off	Arrêt	Apagado	Spento
⊖	Ein-Aus	On-Off	Marche-Arrêt	Encendido-Apagado	Acceso-Spento
⌚	Bereitschaft	Stand-by	Attente (veille)	Espera	Disponibile
▲	Lautstärke	Volume	Volume	Volumen	Volumen
⚖	Balance	Balance	Balance	Balance	Balance
🎵	Höhen	Treble	Aiguës	Agudos	Alti
🎵	Bässe	Bass	Graves	Graves	Bassi
🔊	Lautsprecher	Loudspeaker	Haut-Parleur	Altavoz	Alto parlante
🎧	Kopfhörer	Headphones	Casque	Auriculares	Cuffia
📱	Hörkapsel	Earphones	Ecouteur	Auricular	Cuffia
📴	Stummschaltung	Muting	Silencieux	Circuito silencioso	Sintonia Silenziosa
📴	Abstimmen	Tuning	Syntonisation	Sintonía	Sintonia
📴	Empfangsfrequenz-Regelung	Automatic frequency control	Contrôle automatique de fréquence	Control automático de frecuencia	Controllo automatico delle frequenza
➡	Normal-Lauf	Normal-run	Défilement normal	Velocidad normal	Sfilamento normale
➡	Schnell-Lauf	Fast-run	Défilement rapide	Velocidad rapida	Sfilamento rapido
⏸	Pause	Pause	Pause	Pausa	Pause
➡	Auswurf	Eject	Ejection	Expulsión	Eiezione
⏹	Stop	Stop	Stop	Stop	Stop
⏹	Stop / Eject	Stop / Eject	Stop / Eject	Stop / Eject	Stop / Eject
🎤	Microphon	Microphone	Microphone	Micrófono	Microfono
📼	Tonbandgerät	Tape recorder	Magnétophone	Magnetófono	Magnetofono
📼	Aufnahme	Recording	Enregistrement	Grabación	Registrazione
📼	Wiedergabe	Play-back	Lecture	Reproducción	Riproduzione
📡	Antenne	Aerial	Antenne	Antena	Antenne
📡	Dipole	Dipole	Dipôle	Dipole	Dipole
📡	Tuner	Tuner	Radio-récepteur	Sintonizador	Tuner
📼	Plattenspieler	Pick-up	Lecteur de disques	Giradiscos	Giradischi
📼	Mono	Mono	Mono	Mono	Mono
📼	Stereo	Stereo	Stereo	Estereo	Stereo
🕒	Uhr, Timer	Clock, Timer	Horloge, minuterie	Reloj, Timer	Orologio, Timer
➡	Output	Output	Sortie d'un signal	Salida de señales	Uscita di segnale
➡	Input	Input	Entrée d'un signal	Entrada de señales	Ingresso di segnale
#	Trimmer	Trimmer	Trimmer	Trimmer	Trimmer
🔧	Einstellregler	Adjuster	Potentiomètre ajustable	Potenciometro ajustable	Trimmer ohmico
🔧	Abgleichbarer Kreis	Circuit can be aligned	Circuit à aligner	Circuito ajustable	Circuito a alineare
🔧	L.E.D.	L.E.D.	L.E.D.	L.E.D.	L.E.D.
🔧	Photodiode	Photodiode	Photodiode	Fotodiodo	Photodiodo
●	Messpunkt	Test point	Point test	Punto de prueba	Punto di riferimento

NE 5532 N
NJM2041DD

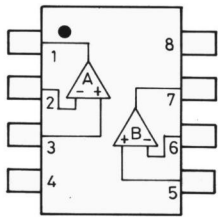

- 1. A OUTPUT
- 2. A-INPUT
- 3. A+INPUT
- 4. V-
- 5. B+INPUT
- 6. B- INPUT
- 7. B OUTPUT
- 8 V+

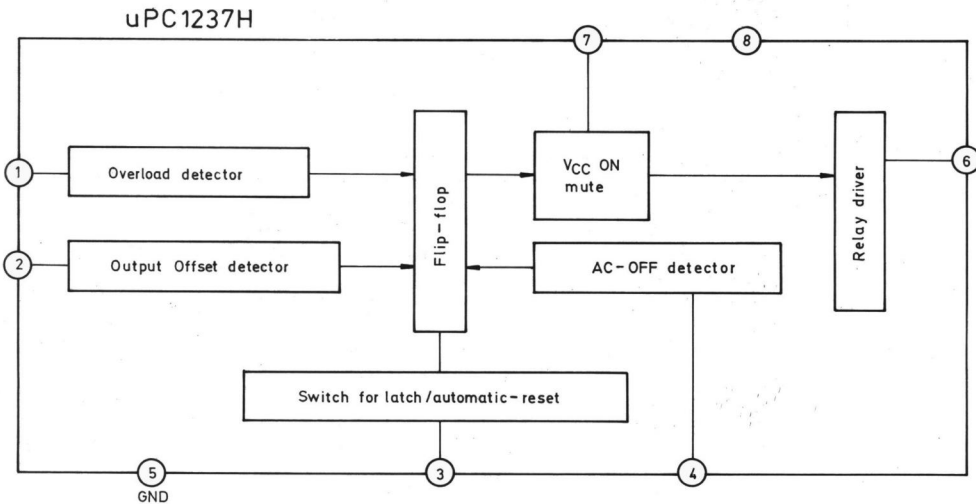

EINSTELLUNGEN	ADJUSTMENTS	REGLAGES	REGLAJES	REGOLAZIONE
Ruhestromeinstellung Rest current adjustment Réglage du courant de repos Ajuste de la corriente de reposo Regolazione della corrente permanente				4 mV
				4 mV

Grundplatte
P.C.B., Power supply/amplifier
Platine alimentation/amplificateur

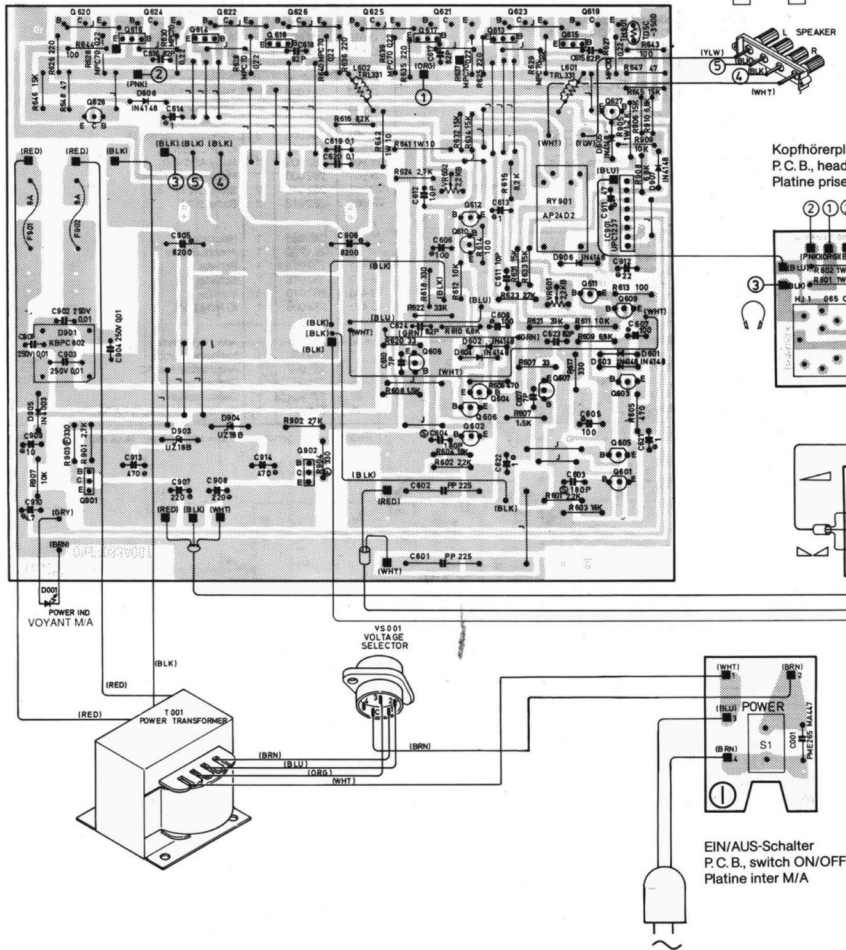

Kopfhörerplatte
P.C.B., headphone-jack
Platine prise-casque

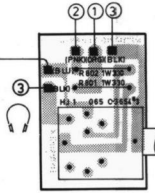

Volumeplatte
P.C.B., controls
Platine potentiomètres

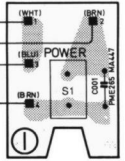

EIN/AUS-Schalter
P.C.B., switch ON/OFF
Platine inter M/A



Anschlußplatte
P.C.B., sockets
Platine prises

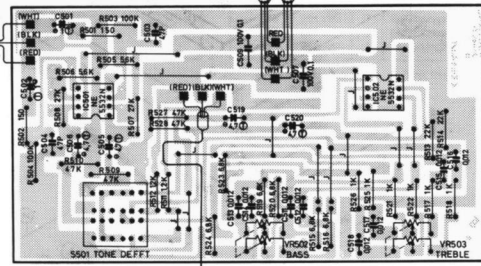
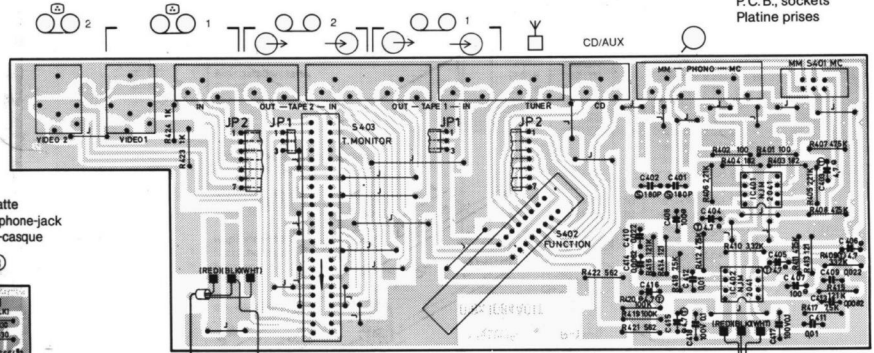

Klangstellerplatte
P.C.B., tone
Platine tonalité