

SERIAL NUMBER

dynaco **SCA-80Q**

This number must be mentioned in all communications concerning this equipment.

INSTRUCTIONS FOR ASSEMBLY OPERATION



dynaco inc.

COLES ROAD & CAMDEN AVENUE / POST OFFICE BOX 88
BLACKWOOD, N. J. 08012, U.S.A.

Bob01605@aol.com

CONTENTS

Operating Instructions	3	Schematic Diagram	16
Installing your SCA-80Q	6	In Case of Difficulty	28
Optional Connections	6	Service and Warranty Information	30
Listening to Dynaquad Sound	7	Parts List	31
Technical Information	8	Alternate AC Line Connections	32
Assembly Instructions	9	Pictorial Diagram	Insert

SPECIFICATIONS

POWER OUTPUT RATING: Less than 0.5% total harmonic distortion at any power level up to 30 watts continuous average power per channel into 8 ohms at any frequency between 20 Hz and 20 kHz with both channels driven, with FTC preconditioning. Distortion decreases at lower power levels.

INTERMODULATION DISTORTION: Less than 0.1% at any level up to rated power into 8 ohms with any combination of test frequencies. Distortion decreases at lower power levels.

FREQUENCY RESPONSE: (at 1 watt output into 8 ohms)
 High level inputs: ± 0.5 dB from 15 Hz to 50 kHz.
 Phono input: ± 0.5 dB of RIAA equalization.

NOISE: High level inputs: 80 db below rated output.
 Phono input: More than 60 db below rated output.

INPUTS: RIAA magnetic phono: 47,000 ohms; 3 mv.
 Special low level: (2nd phono); 47,000 ohms; 3 mv.
 High level: (radio tuner, tape amp, spare);
 100,000 ohms; 0.13 volt.

OUTPUTS: Front or Main Speakers: 4 to 16 ohms.
 Rear Speakers: 8 ohms, or as Remote: 8 or 16 ohms.
 Front panel headphones: 4 ohms or higher.
 Tape output: 600 ohms from phono input
 (same as source on high level inputs).

tone control range: ± 12 db at 50 Hz and 10 kHz.

CONTROLS: Selector Switch, Volume, Balance, Bass, Treble, Tape Monitor Switch, Loudness Compensation Switch, Filter Switch, Stereo-Mono-Blend Switch, Speaker Switch, Power Switch.

SEMICONDUCTOR COMPLEMENT: 20 transistors; 10 diodes.

DAMPING FACTOR: Greater than 40 from 20 Hz to 10 kHz.

SEPARATION: 65 db by IHF standards;
 50 db or more from 20 Hz to 10 kHz.

SIZE AND WEIGHT: 13 $\frac{1}{2}$ " x 4 $\frac{1}{4}$ " x 10" deep.
 16 pounds (7.2 kg.).

POWER CONSUMPTION: 250 watts maximum; 35 watts quiescent; 50/60 Hz @ 100, 120, 220, or 240 volts AC.

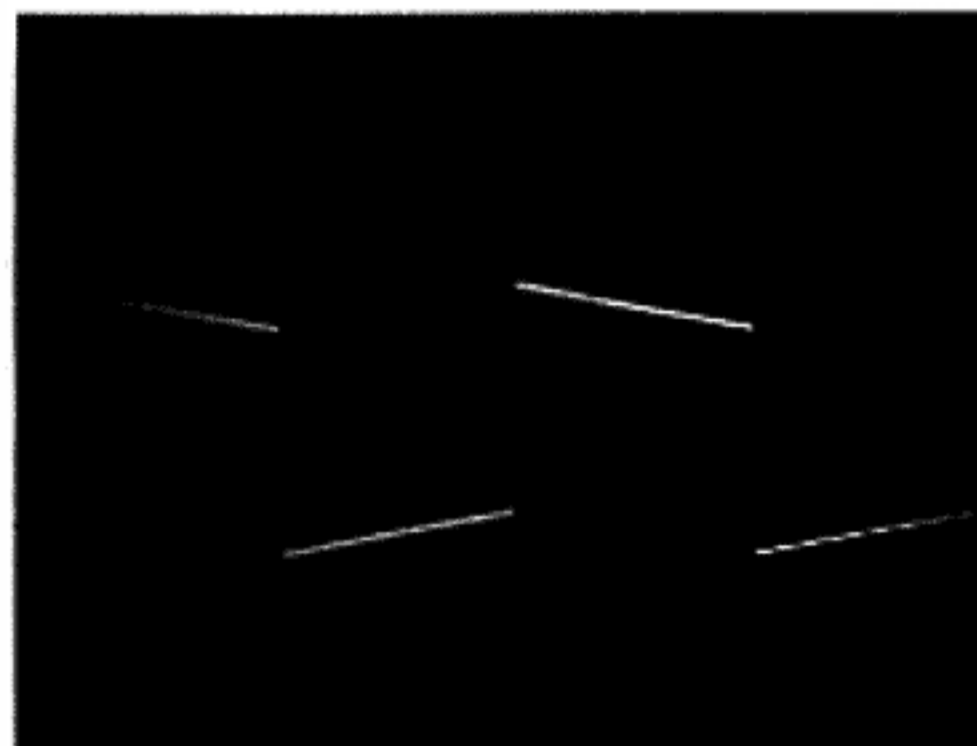

100 Hz



1 kHz



10 kHz

SQUARE WAVE PERFORMANCE: This is a good indication of linearity from 10 Hz to 100 kHz, since good square wave reproduction requires bandwidth in excess of 1/10th to 10 times displayed frequency.

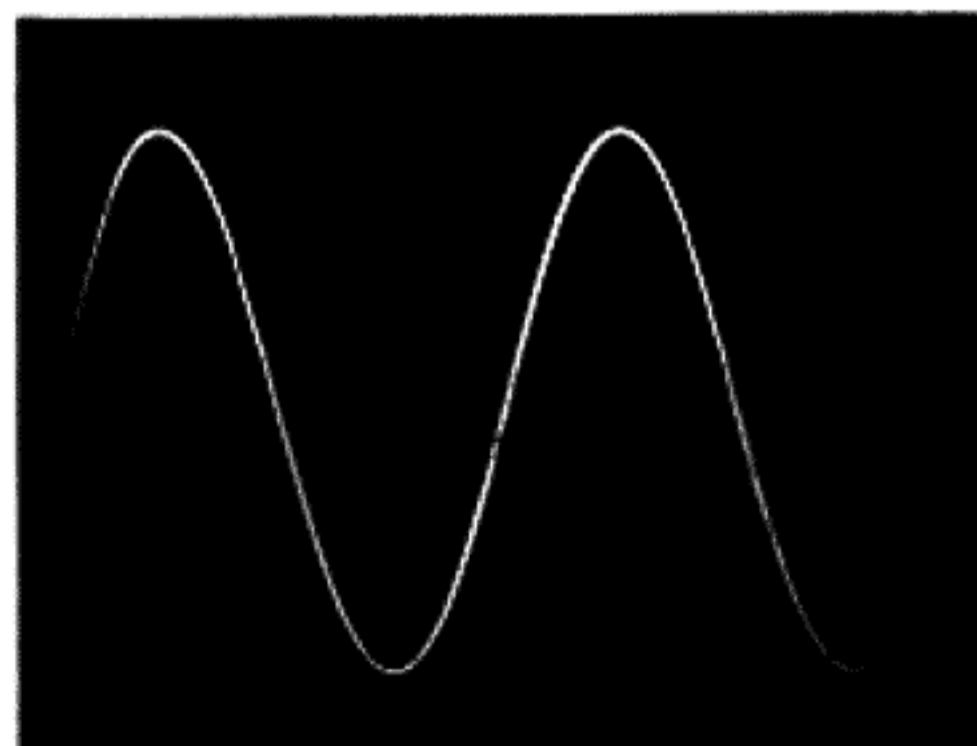

LOW POWER FREEDOM FROM DISTORTION: at 1/10th watt, a 20 kHz sine wave (the most difficult audio frequency) shows absolutely no signs of crossover or notch distortion.

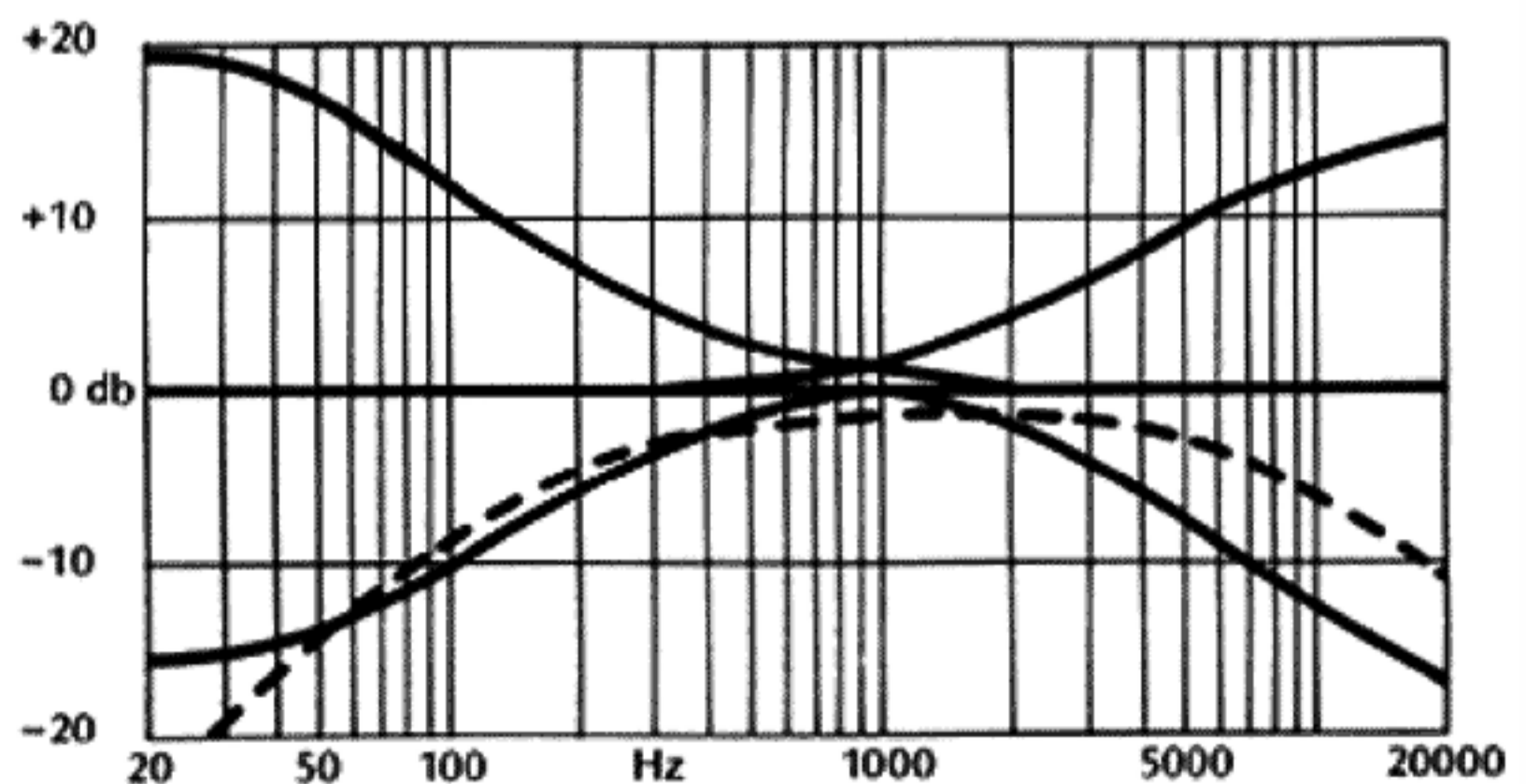

tone control range

Narrow band filter characteristic shown as broken line.

THE DYNACO SCA-80Q

Do not attempt to install or use this amplifier until the section "Operating Instructions" has been carefully read.

The Dynaco SCA-80Q is an all silicon solid state stereo control amplifier of exceptionally high quality. It functions as the control center for all mono or stereo signal sources, such as a record player, radio tuner, tape recorder, television sound, etc., and provides output connections from two 30 watt power amplifiers for either two or four loudspeakers, as well as a front panel jack for stereo headphones. Thoughtful planning has provided exceptional flexibility with remarkable ease of operation.

The SCA-80Q incorporates special circuitry which enables Dynaquad™ 4-dimensional playback for increased realism from a four speaker system without any additional electronics. Alternatively it may be used as a conventional two channel stereo amplifier with provision for optional connection of a second pair of speakers in a remote location.

The SCA-80Q has been designed to be used under normal conditions without special safety precautions, just as if it were a high grade tube amplifier. There are no circuit breakers, speaker fuses, or other resettable devices to impede the use of the SCA-80Q under any reasonable conditions of use or abuse. This is achieved by using novel circuits (on which patents are pending) which automatically and instantly protect the amplifier.

The components in the SCA-80Q are of the highest quality to protect against failure, both now and for many years

in the future. The transistors have been selected for minimum noise and distortion in sustained use. All parts are used conservatively with close tolerances to assure proper operation, and all four etched circuit modules in the kit have been pretested under actual use conditions to ensure that every unit, after assembly, will meet the specifications normally associated with laboratory prototypes.

The specifications of the SCA-80Q speak for themselves. The distortion at low levels is comparable to that of the finest tube designs, while the high power distortion remains inaudible. Specifications do not reveal all the facets of sound quality, however. In use with varying program material, the SCA-80Q justifies its design efforts to have qualities of ease and naturalness always sought and rarely achieved in solid state designs. There is no extra brightness or stridency which is unfortunately sometimes attributed to high fidelity sound, but rather there is an impression of limitless range and effortless handling of the highest power peaks.

Like any precision equipment, the superior capabilities of the SCA-80Q will best be realized when it is properly connected and operated. Therefore, read these instructions, and make the specified connections to the input audio source and to the loudspeakers *before connecting the amplifier to a source of AC power.*

OPERATING INSTRUCTIONS

Connection from Phonograph

The pair of input sockets marked *Phono* provide RIAA equalization for magnetic phonograph cartridges. They may be used with all normal magnetic cartridges having maximum inputs up to 80 millivolts and designed for a load impedance of 47,000 ohms. The upper row of input connections is intended for the *left* channel.

Special Input

This input provides a second low level option which is normally wired for a second magnetic cartridge with RIAA phonograph equalization, enabling the connection of two record players—a turntable and a record changer, for example. Other connections are possible with internal wiring changes, as described in the section "Optional Connections" later in this manual.

Ground Connection

Some record players or tape machines have an extra wire which is to be attached to the preamplifier chassis. A grounding screw *Gnd* is provided for this purpose. Under some unusual conditions of use, where it is advisable to ground the system to a water pipe or similar earth connection, this screw can serve as the connection point.

In general, it is advisable to use the *minimum* number of separate ground leads necessary to achieve lowest hum. Some experimentation may be necessary, but extra leads often cause an increase in the hum level of the system.

Connection from Radio Tuner and other High Level Sources

The *Tuner* and *Spare* inputs are identical and receive flat high level signals from AM/FM/Multiplex radio tuners, additional tape recorders, audio signals from a TV set, etc., via regular shielded cables.

Connection from Tape Recorder

Most tape machines available today include playback preamplifiers. The cables from their "preamp output" or "line output" sockets should be connected to the *Tape Amp* inputs, and the selector switch turned to *Tape* on the SCA-80Q. This input can also be selected by the *Monitor* switch, as described later.

If you have a tape deck which does not contain playback electronics, it is possible to add the necessary equalization components to enable such playback through the *Special* input. See "Optional Connections" later in this manual.

Connection to Tape Recorder

If your tape machine has recording facilities, audio cables should be connected from the *Tape Out* sockets on the SCA-80Q to the "radio," "high level" or "line" inputs on the recorder. The recorder inputs should require signal levels nominally between 100 millivolts and one-half volt for full recording level. Microphone inputs on a recorder are not suitable because their sensitivity is too high.

Tape Out connections are made in the SCA-80Q ahead of all controls except the selector switch so that these controls may be operated to adjust the amplifier signal to the speakers during the recording process without affecting the signal going to the tape recorder. These outputs are at the same level and impedance as the source for all high level inputs, and are low impedance outputs from the phono preamplifier stages. They are ahead of the *Mode* switch too, so each output is independent. They should *not* be externally connected together with a Y adapter for monophonic recording from a stereo source.

If you wish to record monophonically from a stereo phono cartridge, it will be necessary to parallel the outputs of the cartridge itself in accordance with the manufacturer's instructions. Then one audio cable from either

(but not both) *Tape Out* socket may be connected to the single input on the recorder. If extensive mono recording from stereo phono sources is likely, see "Optional Connections" in this manual. Mono recordings from high level sources such as a tuner present no problems because the tuner output can be switched to mono.

The SCA-80Q does not provide the equalization and bias requirements of a complete tape recording preamplifier. It therefore cannot be used as such.

Connection to Loudspeakers

The SCA-80Q is provided with four pairs of black and gold output terminals, each indicated by a loudspeaker symbol. If one pair of speakers is used for conventional two-channel stereo, connect them to the top row of terminals. A second pair of speakers *located in the same room* enables the benefits of Dynaquad™ 4-dimensional reproduction. These rear speakers are connected to the bottom row of output terminals.

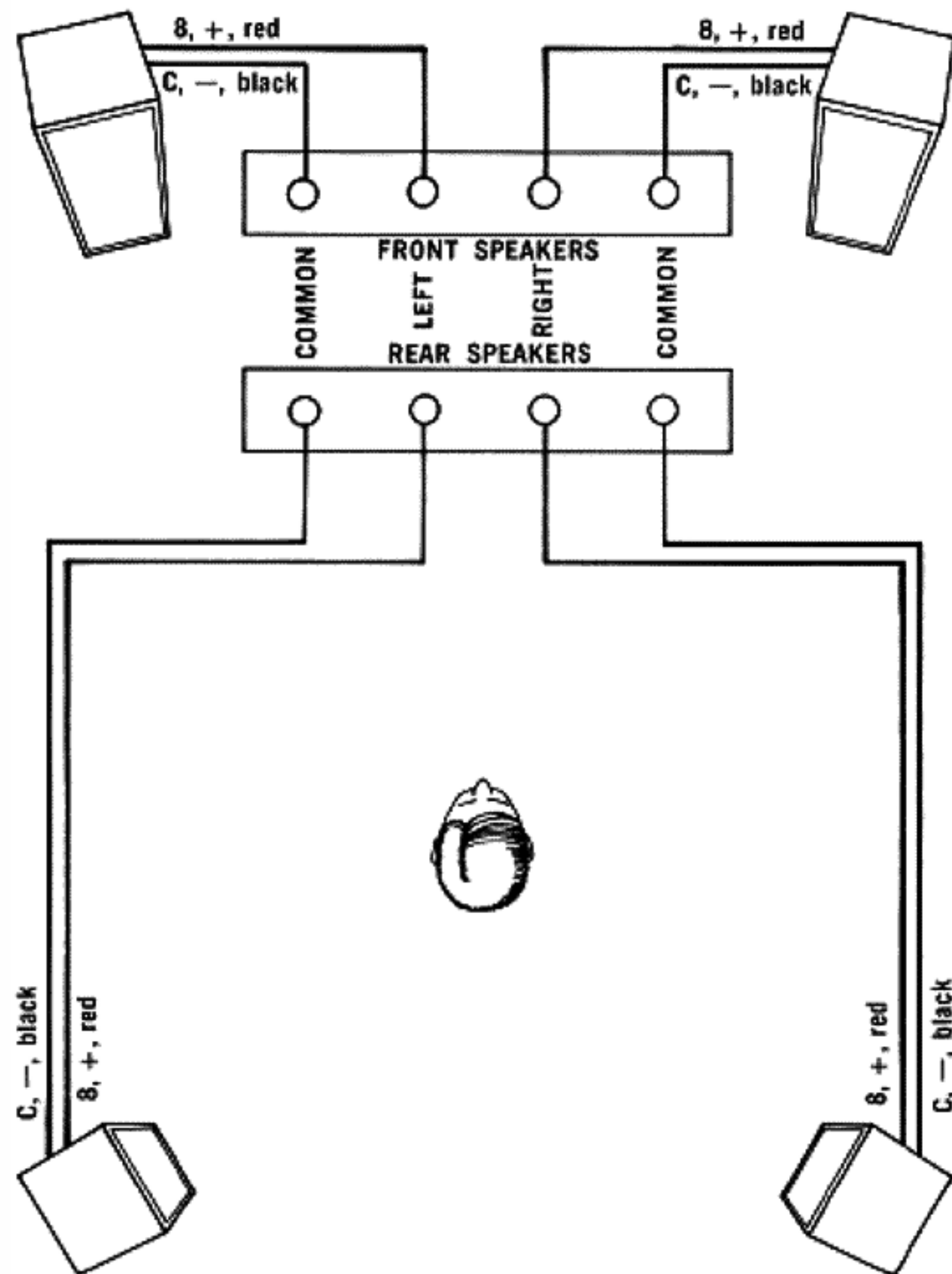

If you prefer to use the second pair of speakers in a remote location, so that conventional two-channel stereo is heard in both rooms, the remote speakers are connected to the bottom row of output terminals, and *in addition* a short piece of wire (jumper) must be connected from the top left *common* terminal to the bottom left *common* terminal.

Each speaker is connected to a black or *common* terminal and to the adjacent gold or *live* terminal. The black terminals are connected together internally, so you can use other equipment which requires common output grounds. *You must be certain that the polarity of such output connections is never reversed, and that the live sides are never accidentally connected together in accessory equipment.*

"Spade lugs" are provided for attaching to the speaker wires to assure a good connection to the terminals. These can be simply crimped over the bared end of the wire, but if a soldering iron is available, soldering them on will make a more secure connection. If stranded wire (as with lamp cord) is used, the wire strands should first be twisted together or "tinned" with solder to avoid fraying. Make certain that no wire strands are able to touch another terminal or the chassis *before you turn the amplifier on.*

The front speakers may be 4, 8 or 16 ohms rated impedance. The rear speakers of a 4-D system should be 8 ohms; they should be identical models; they should have very uniform impedance characteristics; and their efficiency and sonic characteristics should be similar to those of the front speakers. If the rear speakers are 16 ohms, the 10 ohm resistor inside the back panel should be replaced with a 20 ohm, 10 watt unit. If the second pair of speakers is connected for remote use, they may be either 8 or 16 ohm impedance. Only one speaker should be connected to each pair of terminals.

For speaker cables of less than 50 feet, ordinary #18 lamp cord may be used. For longer distances it is suggested that heavier cable (#16 or #14) be used. The terminals on loudspeakers are marked in different ways, and sometimes are not identified. Corresponding terminals may be marked (+), (8 ohms), (1) or in red. It is important that the "sense" of the wiring to each speaker be consistent, so that all speakers will be connected *in phase*. With lamp cord this is easy because one lead is coded—usually either with a tracer thread wound around one of the wires, or with a slight molded ridge on the outer plastic insulation of one conductor, or with different color conductors.

Two speakers are connected in phase when maximum low frequency output is heard when they are driven from a monophonic source. Lowered output is observed when the connection to *one* of the speakers is reversed (out of phase, or reversed polarity). This is most apparent when the speakers are connected to the same amplifier channel, and are placed side by side, or facing each other a short distance apart for test purposes. In a 4-D system, each of the speakers should be compared in turn with the original if there is any doubt of their phasing.

Speakers which require electrical equalization (through the Tape Amp monitor input and the Tape Output) may be used in a 4-D system *only* if all speakers require the same equalizing networks in the amplifier stages. It is *not* feasible to mix equalized speakers with conventional speakers connected to the same amplifier.

The nominal power rating of the SCA-80Q is based on a load impedance of 8 ohms. Loudspeakers with impedances of 4 or 16 ohms may also be used, with some reduction of the maximum power capability at some frequencies. With a 16 ohm speaker load, maximum power can be expected to be about 26 watts per channel. A more detailed explanation of amplifier power output characteristics is available on request from Dynaco.

Selector Switch

This rotary switch selects your choice of program source in both channels simultaneously. It also enables you to select playback from a tape recorder, differing from the more common arrangement which requires that you operate a separate *Monitor* switch to select the recorder. The SCA-80Q also provides a *Monitor* switch (described later), but selection of the recorder for routine playback is made in the same way as all other inputs to avoid confusion.

Volume Control

The output level of both channels is adjusted simultaneously by this control, with close tracking of the two stereo channels so that the program material will remain in balance over most of its range. This control has been designed to provide a slow increase in volume over the first half of its rotation, and a more rapid volume increase above 12 o'clock. This enables most satisfactory operation with both high efficiency and low efficiency speakers, and with both high and low output phono cartridges.

The relative position of the volume control on different pieces of equipment is not an accurate indication of the power output, because it is affected by input levels and speaker efficiency.

Balance Control

The balance control is normally centered for equal signals in both channels. Rotation to the right shifts the sound source to the right by reducing the left channel level, and conversely. This control has a very gradual change for the first 90° either side of center to facilitate delicate adjustments, but one channel is silenced at either extreme of rotation.

A conventional two speaker stereo system requires a balance control to correct for differing speaker efficiencies, or inequities in room energy distribution, as well as occasional program variations.

A 4-dimensional system utilizes the balance control to achieve precise electrical symmetry in the system, and thus to attain maximum separation. With a 4-D system the balance control is no longer used for shifting left-to-right emphasis. The listener is advised to shift his position to adjust for such inequities.

Tone Controls

The special design of the separate bass and treble tone controls is a patented Dynaco arrangement which assures that the tone controls are "out of the circuit" when they are centered. This provides the perfectionist's performance goal with the convenience of continuously variable correction without the complication of extraneous disabling switches.

The normal or "flat" position is centered, with increasing effect to the right, and decrease to the left. Tone controls alter the original signal to suit the user; but these alterations are deviations from truly accurate reproduction. The reference point should always be the center, which gives no frequency discrimination. The tone controls also help to correct for record compensation characteristics of older discs which do not follow the present RIAA standard playback curve.

Monitor Switch

This switch enables direct comparison of the source signal indicated by the selector switch, with the same signal played back from a separate playback amplifier of a tape recorder. This feature is applicable when recording through the SCA-80Q to a tape recorder which has separate playback preamplifiers and three or more heads designed for simultaneous playback while recording. For example, while recording from a radio tuner, the selector switch is turned to *Tuner*, and *Tape Out* is connected to the recorder input. The playback output of the recorder is connected to *Tape Amp*. You will hear the tuner directly when the Monitor switch is in its normal position, marked *Input*. When the Monitor switch is on *Tape* you will hear the

program a fraction of a second after it has been recorded, now being played back from the tape. For this, the tape recorder's own monitor switch must be left in the *tape, compare, playback* or *monitor* position.

You must remember to keep the Monitor switch on *Input* normally, or you will get no signal from any of the other program sources selected by the selector switch. The Monitor switch serves no purpose when the *Selector Switch* is turned to *Tape*.

Loudness Switch

The *Loudness* switch is normally left *off*, but it may be used at lower settings of the volume control to provide an increase in bass to compensate for the ear's lack of sensitivity to low frequencies at low sound levels. The high fidelity purist usually avoids any such compensation; but many listeners will find this switch, used in moderation, adds listening enjoyment at low levels. This sonic correction does not add boom or muddiness to the reproduction.

Filter Switch

With good program material the filter switch will be left in the *flat* position, or effectively out of the circuit. The *rumble* setting provides attenuation below 100 Hz, minimizing low frequency disturbances. The *narrow band* position rolls off both high and low frequencies simultaneously. It thus makes listening to poorer program material more enjoyable since it does not shift the original tonal balance. High frequencies are attenuated above 6 kHz.

Mode Switch

This switch will normally be left in the *stereo* position with stereo program material, providing full separation of the two channels.

The *blend* position reduces the normal stereo separation to 6 db, as for example when the two speakers are spread too far apart for realistic reproduction of a solo instrument. When using headphones, this position frequently provides more realism by reducing the excessive sonic spread.

The *mono* position parallels the two channels, and is the proper position for listening to monophonic records played by a stereo cartridge, as it eliminates the vertical noise components of the signal. When listening to a monophonic radio broadcast with some tuners, too, some improvement may be noted in this position. If a monophonic source, such as TV sound, is connected to one channel input, this signal will be available through both speaker channels when this switch is in the *mono* position.

Speakers Switch

The *Front* position of this switch plays through only the pair of speakers connected to the upper terminal strip. The *Four* (middle) position connects all speakers, either in the normal 4-D arrangement, or as equivalent-signal Main and Remote pairs when the connecting wire jumper is installed on the back panel as indicated there.

The spring-return *Null* position is used for balancing the 4-D system. First play the program at the normal volume setting, and then while you hold the switch against the spring, adjust the Balance control *slowly* for a precise null (no sound). Then release the switch, and you will have 4-D sound. Occasionally, differing program sources or changes in the volume control setting make it advisable to rebalance for best 4-D results.

Headphone Output

A standard 3-circuit phone plug fits this output, wired so that the tip connection is the left channel. Series resistors attenuate the power amplifier output, and headphones of 4 ohms or higher impedance may be used. When headphones are connected, all speaker outputs are automatically silenced. You should *not* have headphones connected when the Speakers switch is in the *Null* position.

Power Switch

This switch has the obvious function of turning the SCA-80Q on and off, and contains an integral pilot light. It also switches whatever is connected to the lower (switched) AC outlet on the back panel, such as a radio tuner. The top AC back panel outlet, which is always *on*, is used for a record player or tape recorder. Their drive mechanisms cannot then be damaged if the amplifier power is turned off without disengaging the machine.

INSTALLING YOUR SCA-80Q

The SCA-80Q generates some heat in normal use—mostly from the power supply resistors—so adequate ventilation must be provided to ensure long trouble-free life. As with any transistorized amplifiers, higher power outputs increase the heat output proportionately, so you must never limit the air flow through and around the SCA-80Q. Do not set anything on top of the perforated cover. Vertical (face up) mounting is not encouraged, since the heat dissipation is not as effective as in the normal horizontal placement. If the unit *must* be mounted face up, a fan is recommended, and some provision for supporting the weight of the power transformer should be made to avoid distorting the front panel.

If the SCA-80Q is inadvertently left on for a lengthy period of time, no problems will be encountered, for the transistors remain cool except under high signal conditions. With sustained high power output, it is normal for the bottom to get much warmer than the cover, for the heat sinks dissipate heat through the chassis. As with all solid state amplifiers, maximum heat is generated at about half the maximum power output. At full power output from both channels a transistorized amplifier must dissipate as much heat as an equivalently powered tube amplifier. At full power, the SCA-80Q puts out as much heat as a 250 watt light bulb.

Panel mounting requires a single rectangular cutout 13 $\frac{1}{16}$ " by 3 $\frac{1}{16}$ ". The rubber feet are removed for such use. You can simply provide a shelf flush with the bottom of the opening. Be sure to cut out the shelf in the area of the ventilation slots on the chassis. Or, an accessory PBK bracket kit is available from Dynaco for \$2 postpaid. No COD's please. The brackets take the place of the shelf, and can accommodate panel thicknesses up to one inch. Instructions accompany the kit, but note that the hole for one of the mounting bolts is located underneath C7L, and this bolt will be secured *only* by the wing nut provided with the kit. Be sure that C7L is properly clamped flush to the chassis after the bolt is installed.

Cautions to be observed

The SCA-80Q contains circuits which will provide nearly complete protection against abuse (including the cautions noted below), but you should not challenge fate. We all

know that parachutes are quite safe—but why jump to test one? The need for protective circuitry in solid state equipment is a direct result of its inherent susceptibility to failure compared with the ruggedness of vacuum tube equipment. You will avoid possible damage to costly transistors and other components if you follow these few simple rules:

1. Do not connect or disconnect inputs or outputs when the amplifier power is on.
2. If you hear any abnormal noises, turn off the equipment and locate and eliminate the source of the noises before using the SCA-80Q. These noises may result from partially connected audio cables or similar faults not connected with the SCA-80Q, but they can be signals or symptoms of signals of excessive amplitude.
3. Do not operate a tape recorder in the fast wind or rewind mode when the volume control is advanced, as this could produce large signals at inaudible frequencies.
4. Avoid any output connection system which risks directly connecting the "live" side of one channel to the "live" side (gold terminal) of the other channel when stereo (different) signals are involved. This is not likely in any properly wired system or accessory, but an accidental change of polarity in the connections to a system requiring common ground connections could be costly. Of particular note: headphone junction boxes.
5. Avoid shorting together the two wires to a loudspeaker, and do not use any switches in the output of the shorting type. Be sure that no strands of connecting wires are free to touch anything except the intended terminal.
6. Do not operate the amplifier if excessive temperature rise is noted.

OPTIONAL CONNECTIONS

The design of the SCA-80Q makes it easy to "customize" in several ways to suit individual needs. A supplementary data sheet is available on request from Dynaco which outlines the necessary changes to provide the following variations.

The normal wiring of the selector switch provides RIAA equalization for a second magnetic phono cartridge on the *Special* input. Other equalization can be provided, so that the *Special* input can accommodate either direct playback from a tape head, or a microphone, provided that the input load impedance remains at 47,000 ohms.

To enable the *Special* position on the selector switch to be used as a second equalization position for the one phono input, the switch has been designed so that the phono input is not shorted when in the *Special* position. By installing appropriate components on the preamplifier circuit board and connecting a jumper on the back panel from the phono input to the special input socket, a second equalization position is available.

If you wish to tape record monophonically from stereo records, the *Special* input can be wired so that it parallels the two phono inputs and provides a monophonic signal at the tape output jack.

If you wish to *reduce* the sensitivity of the *Phono* input by 6 db, alternative wiring of the equalization components is included in the above data sheet.

If headphones are chosen which require either more or less output level, appropriate value resistors can replace the 120 ohms resistors on the headphone jack.

LISTENING TO DYNAQUAD SOUND

When a monophonic music system is changed to two channel stereo reproduction the broadened sound source and added "liveness" is apparent. Part of this enhancement is in the directional characteristics, but much is the result of an improved spatial sense, which is more subtle. Dynaquad 4-D sound provides both added front-to-rear directionality and marked improvement in recreating the ambience or "hall sound" of the original location. The apparent direction of each sound source is a function of the phase and amplitude relationships of its direct and reflected signals. A two-speaker stereo system is incapable of reproducing all of these signal combinations. The added back speakers in the Dynaquad circuit uncover substantial additional recorded material in normal two channel sources, heretofore hidden, by reproducing *all* of these interrelated signals.

We have long recognized that a soloist appears to be centrally located between the left and right speakers when this signal is recorded equally on both channels. The Dynaquad technique includes a simple method for introducing rear information in a complementary fashion, and a way to reduce the front signals when the two channels are reproduced through the back speakers. This enhances the proportion of rear and reflected sound information in the back speakers, and thus adds front-to-back directionality as well as ambience to the reproduction.

The listener should be centrally located in the rear $\frac{1}{3}$ of the room as the general level of the back speakers is 6 db lower than the front speakers. The back speakers will face the listener from behind, usually are widely separated, and if possible, are best located above ear level. Although lower cost limited range speakers can be used in back, irregular response from poor speakers will cloud the capabilities of the main speakers, and weaken the reproducing chain. The back information includes signal components in the full audio spectrum. The lowest bass frequently contributes the most in added ambience—those characteristics which define the acoustics of the recording hall. The higher frequencies provide localization. As new recordings include specific rear sources, proper reproduction dictates comparable quality speakers in that sector.

The degree of increased realism which the Dynaquad system provides over conventional two channel stereo will vary with the program material. With existing two-channel material the benefits you will derive are largely random and will depend on the particular recording techniques employed. However, such benefits are dramatic on many recordings, and it is a rare performance which does not show some improvement.

From your current recorded library select material which was recorded "live" with an audience, as well as recordings made in halls particularly noted for their fine acoustics. Among the pop material, look for selections which employ special sonic effects, too. Works which employ sizeable choral ensembles are also good candidates for 4-dimensional benefits, as well as material noted for unusually wide stereo separation.

Begin by playing the selection with the Speakers switch in the Front position, and then switch to 4-D. Audience participation, including applause, will surround you, rather than appearing in front of you. In pop material, you may even find certain instrumentalists coming from behind you—the result of unintentional microphone misphasing. Organ works will frequently reveal added low end power. On many classical recordings, the initial impression when

switching from two to four dimensions may not seem so dramatic, but after extended listening in 4-D, conventional playback will seem dry and lifeless by comparison. It is not uncommon to find that the transition from 4-D back to normal stereo loses more realism than the switch from stereo to mono.

The benefits of 4-dimensional sound will often be most apparent in smaller rooms, where space restrictions were previously a significant handicap in reproducing really deep bass, or in creating any sense of "hall sound".

You should not expect (or want) to hear four separate and distinct channels, as this would be in essence 4-channel monophonic sound. Realistic musical reproduction implies a relationship between all sound channels and significant overlap, or commonality between them. The Dynaquad system takes advantage of this principle to develop the full reproduction potential of the two sound channels and of their phase and amplitude interrelationships. In effect, more information has always been on the record or tape than has been previously reproduced, ever since stereo recordings began. Recording engineers have long striven to find microphone pickup techniques and performer placement in the studio or hall which could uncover more of the "flavor" of the live performance on playback. What no one realized until now was that the prime restriction lay in the basic concept of stereo playback as a two-speaker environment, rather than in the lesser limitations of a dual-channel transmission medium.

The Dynaquad system provides normal stereo reproduction from the front speakers. If you switch off the back speakers, you will hear the same left-to-right separation you always had. If a soloist was recorded in a central location, blended into the two channels, the solo will come from a virtual front center location between the front speakers. A monophonic program played through the Dynaquad system will likewise appear as a centered front source.

Normal Dynaquad program reproduction (in the absence of a specific back signal source) will provide somewhat lower signal levels from the back speakers. This assures that in the usual listening environment, where the listener sits nearer the back speakers, proper placement of instruments or voices will be retained on the sound stage in front of you. Since the back speakers are closer, and form a wider listening angle, the fact that each back speaker reproduces some of the left or right channel information, in addition to the reflected sounds from the rear, provides the more sharply defined differences in intensity which preserve maximum directionality. In effect, the ear senses greater effective aural separation than the electrical signals apparently provide.

The 4-dimensional effects are achieved because the information in front and rear speakers is *different*—not because there is some front information appearing with reduced level in the rear. The added back speakers make it possible for the ear to perceive *new* signal information which contributes to realism, but which has previously gone unnoticed.

Four dimensional sound cannot improve poor recordings or inadequate equipment. The better the reproducing system, the more it may show up any shortcomings. As one example, the proper azimuth alignment of tape heads is essential to full recovery of 4-dimensional information. As the quality of a music system's components goes up, so do the benefits of 4-D sound.

TECHNICAL INFORMATION

CIRCUIT DESCRIPTION

The SCA-80Q has a number of unique circuit features on which there are patent applications. They contribute to the amplifier's exceptionally low distortion, long term reliability, resistance to abuse, and to its remarkable degree of reproducibility which marks a truly successful design. Those not interested in the technology may omit this section. A more detailed technical description for servicing will be found in a later section of this manual.

Each preamplifier channel of the SCA-80Q uses two pairs of *npn* transistors in similar configurations. On each circuit board the first pair is the low level preamplifier for the Phono and Special inputs. The input transistors are selected low noise types. The phono input can handle signals up to 100 millivolts without overload.

The other pair of preamplifier transistors comprises the tone control stage. They operate at the higher signal levels of tuners, tape recorders, etc., as well as from the output of the phono preamplifier stage. The two sections of the preamplifier are interconnected by the selector switch, and all other controls and switches are located after the low level circuitry.

Each pair of transistors has a DC feedback loop to stabilize operating conditions, as well as an AC feedback loop to provide optimum audio performance. The operating parameters of each stage have been critically adjusted to achieve the lowest possible distortion levels.

The special feedback tone control system of the SCA-80Q is an exclusive Dynaco development which provides continuous adjustment of the frequency extremes while providing a specific "center-flat" setting. When the controls are set to the normal mid-point of rotation, they are effectively out of the circuit and have no effect whatsoever on performance. This is accomplished by special Dynaco-designed potentiometers. When the tone controls are operated away from the "flat" center point, the frequency response is varied by changes in the amount of feedback at the frequency extremes.

The amplifier portion of the SCA-80Q includes unique circuitry to provide an unusual amount of protection while delivering exceptional performance. Transistors Q1 and Q2 are a direct-coupled feedback pair providing a high degree of stability and great linearity. This pair drives the power section, Q3 through Q6, which are direct-coupled and include DC feedback stabilization. These four transistors act as a push-pull power transformer in that they do not have voltage gain, but they transform the signal from high impedance to low impedance. All transistors in the driver and power sections are included in one overall feedback loop.

The amplifiers are designed to *reduce*—not just limit—the current through the output stage when there is any tendency to exceed a reference limit as a result of excessive drive signals or heavy loads. This protects both the load (the loudspeaker) and the source (the output transistors).

In the SCA-80Q the output transistors are operated *without quiescent current* and without the consequent heat rise caused by the bias current, eliminating the need for temperature compensating devices. However, the SCA-80Q does not exhibit any signs of the "Class B notch" commonly attributed to a lack of bias current.

The output signal is taken from the junction of Q5 and Q6 through coupling capacitor C7, which prevents DC from

reaching the speaker. An output capacitor large enough to assure unrestricted low frequency response was chosen instead of the conventional and less costly plus-minus output circuit. It eliminates any need for balance adjustments or matching of components, and assures speaker protection in the event of output transistor failure.

All of the large capacitors used in the SCA-80Q are special high-purity "computer grade" electrolytics chosen for maximum reliability. The output capacitors also serve as convenient forms for small value air-core chokes in the output which, in conjunction with an R-C circuit, roll off the response in the RF region (above 500,000 Hz), reducing interference and affording absolute stability under all circuit conditions.

PERFORMANCE TESTS

Special care must be taken when subjecting transistorized amplifiers to laboratory tests. Solid state circuits draw much more current at the frequency extremes than in the mid-band, and tests with other than the 8 ohm load for which the amplifier is designed may also draw higher current. High current raises transistor temperatures, causing increased current demand, so tests must be performed quickly under these conditions to avoid the action of the protective cut-back circuits which limit the current in the SCA-80Q for safety reasons. The action of the protective circuitry may yield erroneous results, such as a notably lower apparent power output for rated distortion.

High power measurements should first be "set up" with a low input signal, and then raised to a previously determined level for a quick reading. The extended power and frequency response of the SCA-80Q requires that even low power tests above and below the audible range be made quickly to avoid protective cut-back. This limits the duration of high frequency square wave tests, for example.

Prolonged tests at high power levels, at the frequency extremes, or with abnormal load impedances require adequate thermal recovery time. Without it, the transistors are rendered more susceptible to subsequent overload, and the safety margin afforded by the protective circuits is sharply reduced. Callous disregard of these effects may result in eventual failure, for there is no such thing as absolute protection against deliberate abuse.

Some of the heat generated is dissipated through the heat sinks to the chassis, so the bottom of the amplifier will get quite hot during tests. The maximum dissipation in transistorized circuits occurs at about half power.

The line fuse in the SCA-80Q has been chosen to provide maximum protection while allowing short duration currents in excess of its rating. The current demand for both channels operating at full power steady-state at 20 kHz (the severest test), for example, will slightly exceed the fuse rating, but the slo-blo fuse will handle this for several seconds.

When making full power tests at the frequency extremes, it is important that the line voltage be corrected for power line drop because of the high current demand. The capability of the supply will be limited by excessive line losses, and the indicated distortion may rise at maximum power when both sides are driven simultaneously.

ASSEMBLY INSTRUCTIONS

GENERAL INFORMATION

Assembly of the SCA-80Q is exceptionally simple when compared to other kits. The preassembled etched circuit boards have saved you much of the work, and the assembly that remains is arranged in an open, uncluttered layout that makes wiring quick and easy. The construction time will be only a few hours, but it is best to work slowly and carefully rather than worry about the time.

Construction will be greatly simplified if you have someone help you by reading the steps aloud, selecting the required parts, and preparing the necessary wire lengths as you proceed.

When you unpack your kit, check off the components against the parts list at the back of the manual. You can identify unfamiliar parts by matching them to the pictorial diagram or photograph.

Have the proper tools at hand before starting assembly. You will need a pencil-type soldering iron of 30- to 60-watt rating with a small tip, long nosed pliers, diagonal cutting pliers, a medium-sized screwdriver, and 60/40 rosin core solder not larger than $\frac{1}{16}$ " diameter. You will also find a damp sponge or cloth helpful to wipe the tip of the iron clean periodically. An inexpensive wire stripping tool is helpful, but some people prefer a single-edged razor blade for removing the insulation.

SOLDERING INSTRUCTIONS

A good solder connection does not require a large amount of solder around the joint. A well-made connection looks smooth and shiny because the solder *flows into the joint* when both parts are hot enough.

There are four steps to making a good solder connection:

1. Make a good mechanical connection.
2. Heat *both* parts with the tip of the iron *at the junction*.
3. Apply solder to the *junction* until it melts and flows.
4. Allow the connection to cool undisturbed.

ALL SOLDERING MUST BE DONE WITH A GOOD GRADE OF ROSIN CORE SOLDER.

Under no circumstances should acid core solder be used. Unmarked solder, cheap solder or any of doubtful origin should be discarded, and *separate solder fluxes should never be used*. The warranty is voided on any equipment in which acid core solder or acid type fluxes have been used. Silver solder is not suitable. The recommended solder is 60/40 (60% tin, 40% lead) **ROSIN CORE**. Do not confuse this with 40/60, which is harder to use.

If you have a soldering gun, it should be used with care, especially when working on the circuit boards. A soldering gun can provide more heat than is necessary, with some risk that an unskilled user might damage the board, and because it requires some time to heat each time the trigger is squeezed, many users tend to make poor solder connections simply because they do not wait long enough for it to reach its operating temperature each time.

You should realize that delicate components such as transistors are less likely to be damaged in the soldering process if you use a hot iron for a short time, rather than a cooler iron for a longer period. You will also make a better connection with the hot iron. If you keep the iron clean by wiping the tip frequently, and occasionally add a small amount of solder to the tip, it will aid the transfer of heat

to the connection. Do not allow too much solder to build up on the tip, though, or it may fall onto adjacent circuitry.

One of the best ways to make a good mechanical connection is to bend a small hook in the end of the wire, and then to crimp the hook onto the terminal lug. The amount of bare wire exposed need not be exactly $\frac{1}{4}$ -inch, but if it is too long, the excess might touch another terminal lug or the chassis. Do not wrap the wire around the lug more than one time, as this makes the connection difficult to remove if an error is made.

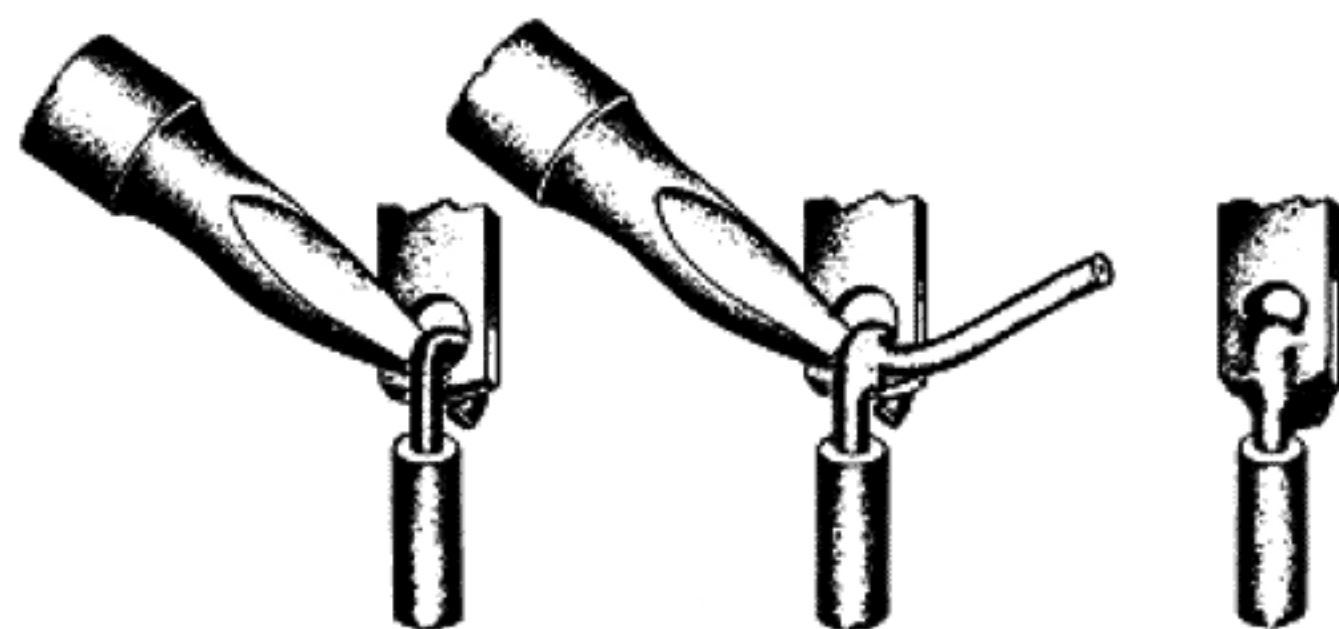
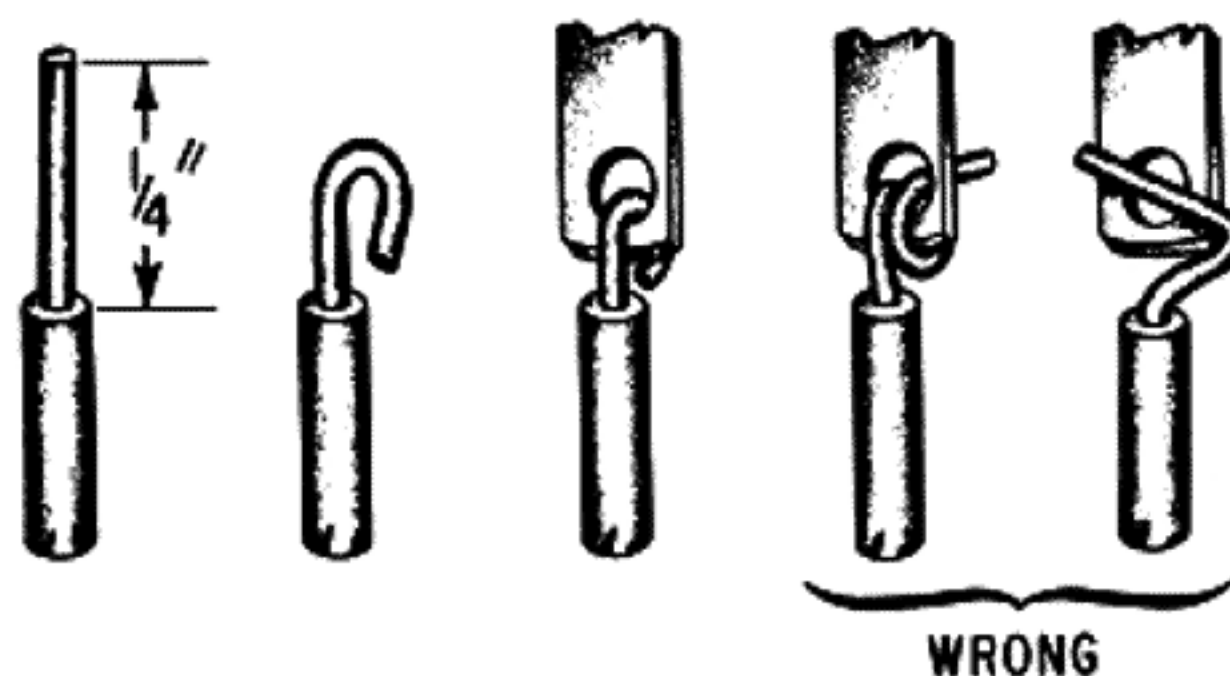

When soldering a lead to an eyelet on the circuit board, the SCA-80 makes it easy to apply the iron to one side of the board while the tinned wire end is pressed into the solder-filled eyelet from the opposite side. When the eyelet is heated, the wire enters easily, but be careful that you *do not push the wire all the way into the eyelet up to the insulation*. If you do, you will not be able to see if you have made a secure connection, or if more solder is needed to provide a smooth flow from the wire, to the eyelet, and onto the circuitry on the board.

WIRING THE KIT

The position of all wire leads should follow the diagram and photograph closely, bearing in mind that the pictorial diagram has necessarily been distorted somewhat to show all connections clearly. See that uninsulated wires do not touch each other unless, of course, they are connected to the same point. It is especially important that uninsulated wires or component leads or terminals do not touch the chassis accidentally.

Whenever one wire is to be soldered to a connection such as a lug or a transistor lead, the instructions will indicate this by the symbol (S). If more than one wire is to be soldered to the same point, the instructions will cite the number of wires that should be connected to that point when it is to be soldered. If no soldering instruction is specifically given, do not solder; other connections will be made to that point before soldering is called for.

When the instructions refer to "tinning" a wire, apply the iron to the bared wire end, and after a moment, touch the solder to the wire so that the solder lightly coats the wire. This makes it easier to get a good connection when the wire is inserted into an eyelet, for example.

Components such as resistors and capacitors are marked individually with their values, or with a color code. The color code will be given in the instructions when needed. The first color band on a resistor is the one nearest the end. Any fourth color band may be ignored.

Check your work after each step, and make sure the entire step has been completed. When you are satisfied that it has been correctly done, check the space provided and go on to the next step. Be sure you read carefully the explanatory paragraphs in the assembly instructions.

Many of the wiring steps will call for "preparing" a wire of a certain length and color. This involves cutting the necessary length of wire and stripping $\frac{1}{4}$ inch of insulation from each end. This is most easily done with wirestrippers, but diagonal cutters can be used if you are careful not to nick the wire and weaken it. With stranded wire such as transformer leads and line cords, be particularly careful not to cut the strands when stripping the ends. Two coils of heavy gauge wire are supplied for special use indicated in the instructions.

Although the SCA-80Q includes protective circuitry to prevent breakdown in use, only you can prevent breakdown resulting from improper construction. Transistor equipment, unlike much tube equipment, will not tolerate wiring errors, sloppy or incomplete soldering. TAKE THE TIME TO BE NEAT AND ACCURATE, and your amplifier will operate properly at first, and for many years to come.

The four circuit boards and the four power transistors have been in-circuit tested before leaving the factory. This assures that all of the semi-conductors, as well as most of the other parts, are performing to specifications. Only the interconnection of these parts is left to you.

To protect the selector switch it is suggested that it be left in its protective wrapping until called for in the instructions.

Two sizes of screws and nuts are supplied with the kit: the small #4 size, and the large #6 size. For your convenience, no #4 lockwashers are supplied. Use #6 lockwashers when #4 hardware is called for. A "set" of hardware includes one each screw, nut and lockwasher.

All mounting screws are installed from the *outside* of the chassis, and a lockwasher is used under each nut, except when otherwise specified.

Also supplied are 8 #6 self-tapping screws, which can be identified by their tapered shape and scored tip. These should be separated from the rest of the hardware and set aside until called for in the instructions.

Mechanical Assembly

Place the chassis front panel before you, oriented as in the pictorial diagram.

- 1() Select the QPTT rocker switch (16 lugs), two of the $\frac{3}{4}$ " screws, the two *brass plated* (longer) tubular spacers, lockwashers and nuts. Note that one

position of the rocker has a spring-return to center. Insert the screws through the panel at location OS, slip the spacers over the screws, and install the switch so that the spring-return position is towards the *center* of the panel.

The remaining switches do not require either lockwashers or nuts as they have tapped, extruded mountings.

- 2() Select the power switch (with the clear rocker) and two #4 (smallest) screws. Install it in location PS so that the two small wires coming from inside the switch are toward the *bottom* of the chassis (where switch OS was installed).
- 3() Select one of the two DPTT rocker switches (8 lugs), two of the $\frac{3}{8}$ " natural finish tubular spacers, and two $\frac{3}{4}$ " screws. Install the switch at location BS.
- 4() Select the remaining DPTT rocker switch and install it in location FS with the remaining tubular spacers and $\frac{3}{4}$ " screws.
- 5() Select the two DPDT rocker switches (6 lugs) and install them in locations LS and MS with #4 screws.
- 6() Select the phone jack, and place the flat $\frac{3}{8}$ " washer over the threaded portion, followed by the $\frac{3}{8}$ " lockwasher. Install the jack in location HP with the lugs positioned as in the diagram, and fasten with a $\frac{3}{8}$ " nut.
- 7() Select the volume control (8 lugs), part #177254. Insert the control in location VC. Be sure the locating tab on the control engages the small hole in the front panel, and fasten with a $\frac{3}{8}$ " nut.
- 8() Install the balance control, part #167224, in similar fashion in location BC with a $\frac{3}{8}$ " nut.
- 9() Install the bass control, part #167514, in similar fashion in location DB with a $\frac{3}{8}$ " nut.
- 10() Install the treble control, part #167404, in similar fashion in location DT with a $\frac{3}{8}$ " nut.

This completes the mechanical assembly of the front panel. Location SS is vacant for the present. Set this assembly aside, and place the back panel in front of you, oriented as in the pictorial diagram.

- 11() Select one of the two 6-socket input strips, four #4 screws and nuts, three lockwashers and one ground lug. All screws are inserted from the outside of the panel. The strip is mounted on the *inside* of the panel, with the ground lug used in place of a lockwasher over the upper left screw. As you tighten the screws, orient the ground lug as in the diagram, and be sure that none of the metal socket mounts contact the chassis.
- 12() Install the remaining 6-socket input strip in the same manner, using a ground lug on the upper left screw.
- 13() Select one of the two 4-lug screw terminal output strips and two sets of #4 hardware. Place the strip on the *outside* of the panel with the lugs toward the inside bottom of the panel. Insert the screws first through the strip, then the panel, fastening them with a lockwasher and nut.

- 14() Install the remaining 4-lug screw terminal strip in the same manner.
- 15() Install one of the AC outlets in the upper location (marked *unswitched* on the panel) with two sets of #4 hardware with the flange inside.
- 16() Install the other AC outlet in the lower location with two sets of #4 hardware.
- 17() Install the 4-lug terminal strip TS with one set of #4 hardware in the hole between the two AC outlets. Note the lug placement in the diagram.
- 18() Install the fuse holder below the black AC outlet. The rubber washer stays outside the panel, and the flat side of the mounting hole engages a similar flat on the holder for proper orientation. Secure it with the lockwasher and nut.

This completes the mechanical assembly of the back panel. One large hole remains vacant for the present. Set this assembly aside, and place the main chassis bottom plate in front of you, flanges upwards.

- 19() Select the four rubber feet, and four sets of #6 hardware. A foot is mounted in the hole in each corner of the chassis by turning the bottom plate over, placing the foot over the hole, and forcing the screw through the foot until the screw head is recessed. The foot mounted in the corner where the power transformer will be located should be mounted loosely. The other three should be fastened securely, but not so tightly that the foot becomes distorted.

The next 4 steps describe the installation of the four capacitor mounting brackets. All mounting screws are installed from the outside (bottom) of the chassis. One set of #6 hardware is to be installed in each bracket *clamp* before mounting. In each case refer to the diagram for the correct orientation of the clamp, and also for the direction of insertion of the clamping screw. This will facilitate servicing access if required in the future.

Because the brackets are flexible, you will find that the capacitors will be held most securely if they are temporarily slipped into each bracket for sizing when the bracket mounting bolts are tightened. While squeezing the bracket around the capacitor, tighten all the mounting bolts, starting first with the bolt farthest from the clamp. Then remove the capacitor. *Do not remove the outer insulation from any of the three largest capacitors.*

- 20() Select the 1 $\frac{3}{8}$ " diameter (smaller) bracket and three sets of #6 hardware. Install it at the left of the chassis as in the diagram.
- 21() Select one of the three larger (2" diameter) brackets, four sets of #6 hardware, and install it as shown in the diagram at the rear of the chassis.
- 22() Install another of the brackets in the right front corner of the chassis with four sets of #6 hardware.
- 23() Install the remaining bracket on the right side of the chassis with four sets of #6 hardware.

- 24() Install the two "U" shaped brackets in an upright position in the single holes near the front of the chassis with two sets of #6 hardware.
- 25() Remove the foot in the right rear corner of the chassis and install the power transformer with the two red leads toward the center of the chassis, using three additional sets of #6 hardware. Reinstall the foot and tighten it securely.
- 26() Select one of the two long narrow circuit boards, PC-17, and four sets of #4 hardware. To facilitate wiring in later steps, you should remove the solder which fills eyelets 3, 4, 11 and 12 of this board. Heat each eyelet in turn with the soldering iron, and then clear the eyelet with a toothpick. Be careful that no solder splashes onto other parts of the circuitry on the board. Install this board on the *rear inside* of the two "U" shaped brackets with the row of eyelets on top, and the components on the side of the board nearest the power transformer.
- 27() Install the remaining PC-17 board with four sets of #4 hardware on the *front outside* of the two brackets, with the eyelets on top, and the component side of the board nearest the power transformer.

Wiring the Main Chassis

The next 4 steps describe the installation of components on the power supply circuit board PC-19. The placement of each part is marked on the side of the board on which most of the components are mounted by lines to the holes into which its leads will be inserted. Dotted lines indicate parts which are mounted on the reverse (copper) side of the board. *Except where specifically indicated otherwise, the parts should be mounted tightly against the board, just as you see those on the other circuit boards mounted.*

Each part will be identified by a part number, color code, or written value. First bend the leads to fit the space between the marked holes, then push the leads through the holes and spread them slightly to hold the part in place for soldering. *Solder each lead and every eyelet carefully to the copper foil, being sure the solder flows all around the lead and smoothly onto the copper, without any bridges to other parts of the circuitry. Cut off all excess leads. The copper side of the board has been coated with a corrosion inhibitor which is also conducive to soldering, but there is no substitute for good soldering technique.*

- 1() Install the 68 ohm resistor (blue-gray-black) R21. Solder.
- 2() Install the four silicon rectifier diodes #544322, D4, D5, D6 and D7. Be certain the markings are all faced the same way, with the cathode end nearest resistor R21. The ones supplied may be any of the three types shown in the illustration. Although different in appearance, they are electrically equivalent. Solder.

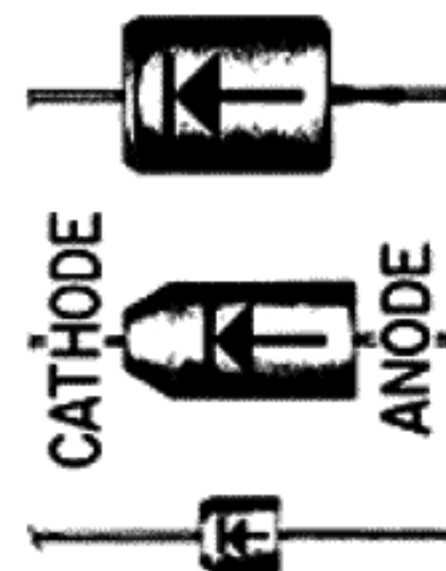

- 3() Install the .01 mfd 500 volt disc capacitor C37 on the inside leads of diodes D4 and D6 (see board diagram page 18). Cut each capacitor lead to $\frac{1}{2}$ " , hook it around a diode lead, and solder each.
- 4() Install the two 7 watt, 5%, 400 ohm resistors R16 on the circuit board. *Do not mount them flush against the board. Allow at least $\frac{1}{8}$ " , but not more than $\frac{1}{4}$ " space between the resistor body and the board for ventilation, as these get quite hot in normal use.* If these resistors are supplied with $\frac{1}{8}$ " molded feet, the feet may be mounted flush to the board. Solder each lead to the eyelet, and *across the eyelet to the copper circuitry.* The most common error in assembling this kit is incomplete soldering of these eyelets, and those in the following step, to the board.
- 5() Install the two remaining 7 watt, 400 ohm resistors R17 on the *reverse (copper) side* of the board, leaving between $\frac{1}{8}$ " and $\frac{1}{4}$ " ventilating space. Solder these on the copper circuit side of the board.
- 6() To make connections to the eyelets easier, "tin" all 9 numbered eyelets on the board now. Apply enough solder to fill each eyelet, and to solder it securely to the adjacent copper circuitry.

The wires in the next three steps are to be connected to eyelets on the circuit board. A good connection is more assured if the wire is first "tinned" by heating it and applying a small amount of solder to the tip before it is connected to the eyelet. In most cases, it is easiest to heat the eyelet from the copper side of the board when the wire is inserted. Hold the wire steady while the connection cools, and then wiggle it to be sure the connection is secure. There should be a smooth flow of solder from the wire to the eyelet, and across the eyelet to the board. If in doubt, reheat the connection and add a bit more solder.

- 7() Strip $1\frac{1}{4}$ " of insulation from one end of the coil of black hookup wire, "tin" the tip, and connect this end to eyelet #7 from the *copper* side of the board. (S). Then clip off this wire at the insulation. This is the easiest way to handle such a short uninsulated wire length.
- 8() Prepare a $4\frac{1}{4}$ " green wire, "tin" both ends, and connect one end to eyelet #6 from the *front* (diode side) of the board. (S).
- 9() Prepare a $6\frac{3}{4}$ " red wire, "tin" both ends, and connect one end to eyelet #5 from the *front* of the board. (S).
- 10() The two right-angle brackets have one leg shorter than the other. The shorter leg is to be mounted to the power supply board, and the longer one to the chassis. They fasten to opposite sides of the board, projecting outwards. One bracket makes contact with the copper circuitry adjacent to eyelet #7. The other is mounted below the diodes. Use two sets of #4 hardware to mount the brackets to the board. In both cases, the screw is inserted first through the bracket, and then through the board.

- 11() With one set of #6 hardware mount the PC-19 board on the chassis. The ungrounded bracket (below the diodes) is fastened at the hole nearest the power transformer at the rear of the chassis.
- 12() Select the two remaining ground lugs, and one #6 screw and nut. Pass the screw through the chassis, through the second PC-19 bracket, and then through the two ground lugs arranged in a "V", and fasten with a nut. A total of 5 wires will be connected to these ground lugs. It makes no difference which is used for any wire.
- 13() Connect the short bare wire from eyelet #7 to one of the ground lugs.

The following 4 steps describe the installation of the power transistors on the black aluminum heat sinks. This requires the application of the white silicon thermal compound supplied in a capsule. It is necessary to assure good heat transfer while maintaining electrical insulation. The quantity supplied is far in excess of what you will need. A uniform film is required on *one* of each pair of mating surfaces.

This thermal compound can be most annoying if carelessly handled. Stray smudges can make your finished amplifier look sloppy. Therefore, clean up any excess with paper tissues as you go along. It is difficult to remove from clothing, and the best removal agent, if needed, is a freon degreasing agent available in a pressure spray can at electronic supply houses.

One of the easiest ways to handle this compound is to apply it with the blade of a screwdriver. However, the screwdriver used should be other than the one employed to install the hardware. The thermal compound must first be applied to the flat base of the transistor. Next the insulator is added over the transistor pins (they are off-center, so orient the insulator properly), and compound is applied to its surface as well. *Only a thin film of compound is necessary.* For easier handling, you may avoid applying compound to the outer edges of the mounting holes. Now carefully *wipe off* any compound from the transistor pins.

Then orient this transistor assembly and the heat sink (see NOTE in Detail A) so that the transistor will be installed in the *deeper* recess of the heat sink with the pins protruding adjacent to the exterior "C" channels. Be sure the correct transistor assembly (with or without the red dot) is first positioned to align the pins with the off-center smaller holes in the heat sink rib, and then install the transistor in the appropriate location. Apply a *slight* twisting motion to assure uniform distribution of the compound. The insulator should lie flat between the heat sink and the transistor, and thus be visible all around the transistor. Then install the appropriate hardware as each step indicates.

- 14() Select a heat sink, an output transistor #571844 *with a red dot* (Part #338-2) one of the thin plastic transistor insulators, the thermal compound, two nylon shoulder washer/spacers, two #6 screws, a lock-washer, a ground lug, and two #6 nuts. Apply the thermal compound to the transistor and insulator, and install this assembly in position Q6 (note that

Q5 shows the mounting sequence, and Q6 is already installed in the drawing). Pass a screw through the transistor mounting flange nearest the outer (left in the drawing) edge of the heat sink. From the other side of the heat sink rib install a nylon shoulder washer/spacer (smaller diameter first) over the screw so that it fits inside the mounting hole. Follow with a lockwasher and nut, finger tight. Install the second screw and shoulder washer in like fashion, followed by the ground lug and nut. Be sure the transistor pins are centered in their clearance holes, orient the ground lug as in Detail B on the next page, and securely tighten the hardware.

- 15() Select a transistor #571844 which does *not* have a red dot (Part #338-1) an insulator, two shoulder washers, two #6 screws, a lockwasher, a ground lug, and two #6 nuts. Apply the thermal compound and install this transistor in the Q5 position on the same heat sink, with the ground lug on the outside (right) edge screw oriented as in Detail B on the next page, and tighten the hardware.
- 16() Select the remaining heat sink, the other #571844 transistor with the *red dot* (Part #338-2) and an insulator, two screws, two shoulder washers, lockwasher, ground lug and two nuts. Apply the thermal compound and install this transistor in the Q6 position, orient the ground lug properly and fasten it securely.
- 17() Select the remaining transistor without a red dot (Part #338-1) the insulator, two screws, nuts, and shoulder washers, a lockwasher and ground lug. Apply the thermal compound and install it as Q5. Check the ground lug and tighten the hardware.

You have concluded the need for the thermal compound, so it may be disposed of. Wipe off any excess, and particularly wipe clean the ground lugs and the transistor pins so that proper solder connections may be made to them.

Each of the two amplifier channels comprises a heat sink assembly, just completed, and a preassembled and tested circuit board. The four items fit together like the sides of

a box, with two adjacent sides (heat sink and board) comprising one channel.

Be careful not to bend the transistor pins, for it is important that neither the pins nor connections to them be allowed to touch the heat sink.

Detail B shows the wiring to the left channel heat sink, with the connections identified by a letter which will follow the number of the transistor, as Q5-E. For convenience you may wish to mark these letters on the heat sink with a soft pencil. Keep your wiring neat, and observe the direction in which each wire is to be oriented on the diagram before soldering. Different right channel wire lengths are given in italics (*in parentheses*).

In some places the instructions will tell you to form a loop in some of the wires. This is done with the tips of long-nosed pliers, to produce a closed ring at the end of the wire that is just large enough to fit snugly over the transistor pins. It is then squeezed around the pin with the pliers to hold it for soldering.

While excessive heat may damage any transistor, the silicon types used in the SCA-80Q are very rugged, and it is more important that you have the transistor pin and the wire you are connecting to it hot enough before you apply the solder, so that the solder will flow quickly over the junction, giving you a smooth connection. A small drop of solder on the tip of the iron will assist you in heat transfer and good soldering. If the solder does not flow easily around the connection, allow it to cool, and try again after the tip of the iron is again hot.

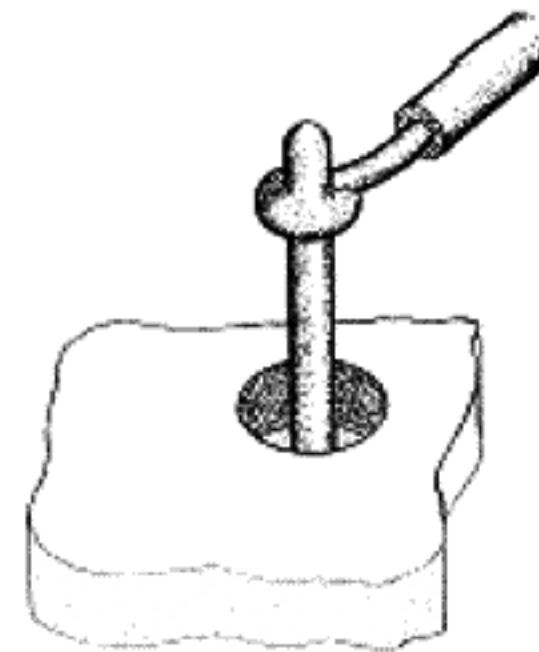

To avoid short circuits to the heat sinks, all connections must be made to the *tip* of the transistor pins, and solder must not be allowed to flow into the recess formed by the hole in the heat sink.

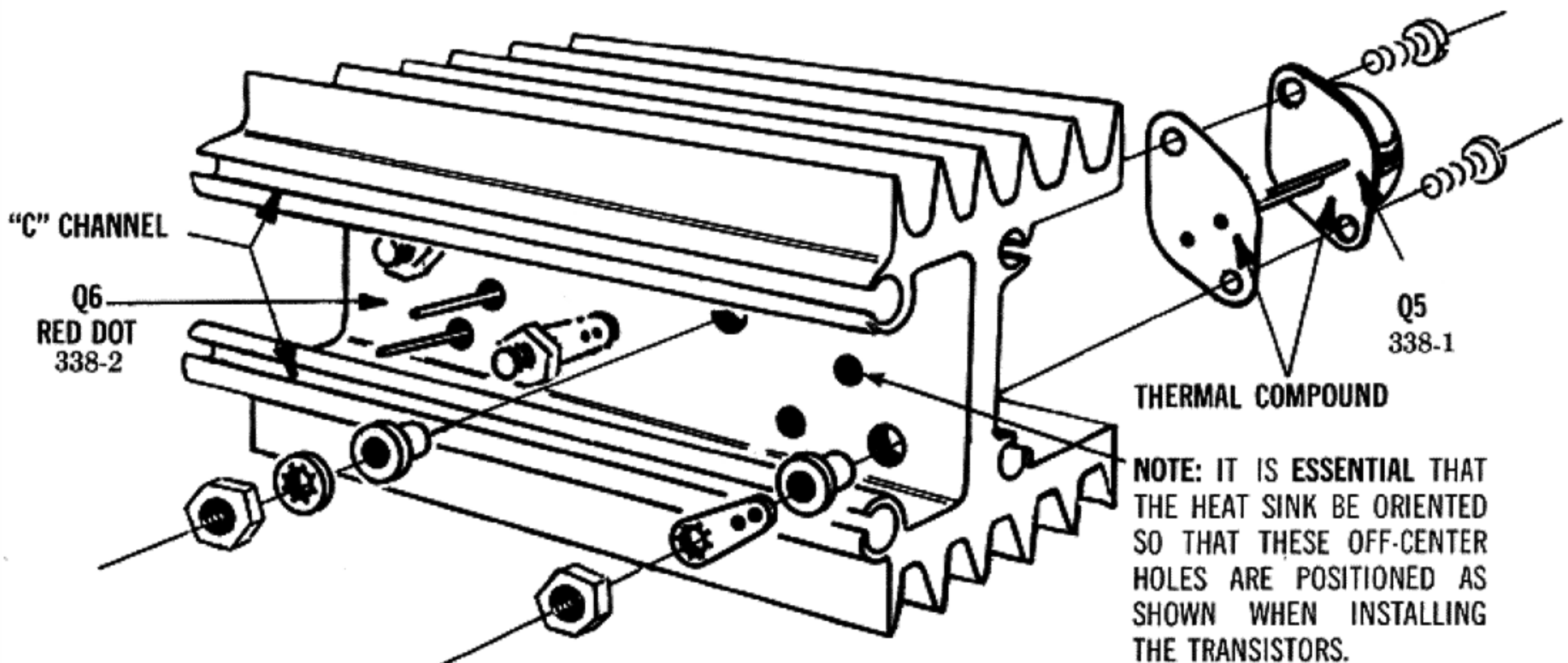

Detail A

- 18() Orient one of the heat sinks as in Detail B, with the ground lug on the end to the right. Select one of the 0.47 ohm resistors (yellow-violet-silver) and trim the leads to a length of $\frac{3}{4}$ ". Bend the leads to form a "U", and form a loop in one lead. Tuck the resistor into the inner-most channel on the heat sink, and pass the tip of the straight lead through lug Q6C. Connect the loop to Q5E. (S).
- 19() Prepare a $2\frac{3}{4}$ " green wire, and form a loop at one end. Connect this from the right to Q5B. (S).
- 20() Prepare a $3\frac{1}{4}$ " green wire and a $2\frac{1}{4}$ " green wire. Connect one end of each wire from the right to lug Q5C. (S-2). Put a right-angle bend near the end of the shorter wire for later identification.
- 21() Prepare a $3\frac{1}{2}$ " black wire, and form a loop at one end. Connect this from the right to Q6E.
- 22() Prepare a $5\frac{1}{2}$ " black wire, and form a loop at one end. Connect this from the left to Q6E. (S-2).
- 23() Prepare a 4" green wire and connect one end from the right to lug Q6C. Bend a hook at the end for later identification.
- 24() Prepare a $6\frac{1}{2}$ " green wire and connect one end from the left to lug Q6C. (S-3).
- 25() Prepare a $3\frac{1}{2}$ " green wire, and form a loop at one end. Connect this from the right to Q6B. (S).
- 26() The heat sink assembly is to be mounted with 4 of the *self-tapping* screws initially set aside. Tilt the chassis upright on the power transformer. Place the heat sink between C9 and C11 on the left side of the chassis, with the solder lugs toward the center of the chassis, and Q6 next to the chassis. Bend the two wires from Q6 towards the chassis rear. Thread the screws into the four "C" shaped channels from the bottom. Do not tighten these screws until all four are properly threaded into the heat sink. Fasten them securely, but do not apply excessive force or the threads may strip.
- 27() Orient the second heat sink as in Detail B. Trim the leads of the remaining 0.47 ohm resistor (yellow-violet-silver) to $\frac{3}{4}$ ", bend them to form a "U", and form a loop in one lead. Tuck the resistor into the channel, slide the straight lead through lug Q6C, and connect the loop to Q5E. (S).
- 28() Prepare a $2\frac{3}{4}$ " red wire, form a loop at one end, and connect this from the right to Q5B. (S).
- 29() Prepare a $6\frac{1}{2}$ " red wire, and a $2\frac{1}{4}$ " red wire. Connect one end of each wire from the right to lug Q5C. (S-2). Put a right-angle bend near the end of the shorter wire for later identification.
- 30() Prepare a $3\frac{1}{2}$ " black wire, form a loop at one end and connect this from the right to Q6E.
- 31() Prepare a $6\frac{1}{2}$ " black wire, form a loop at one end and connect this from the left to Q6E. (S-2).
- 32() Prepare a 4" red wire and connect one end from the right to lug Q6C. Bend a hook in this wire for later identification.
- 33() Prepare a $6\frac{1}{2}$ " red wire and connect one end from the left to lug Q6C. (S-3).
- 34() Prepare a $3\frac{1}{2}$ " red wire, form a loop at one end and connect this from the right to Q6B. (S).
- 35() Mount this heat sink *facing* the other one with the remaining 4 self-tapping screws as before. Bend the two wires from Q6 at the bottom, as well as the longest top wire, towards C9. Lay the chassis flat, and check *both* heat sinks to be certain the connections to the four solder lugs do not touch the black heat sinks, and that all transistor pins are centered in their holes.
- 36() Now "tin" the free ends of each of the wires on the two heat sinks, to facilitate their later connection to eyelets on the circuit boards. Keep the wires clear of the transistor pins when tinning them, to avoid the possibility of a solder splash making a short circuit.

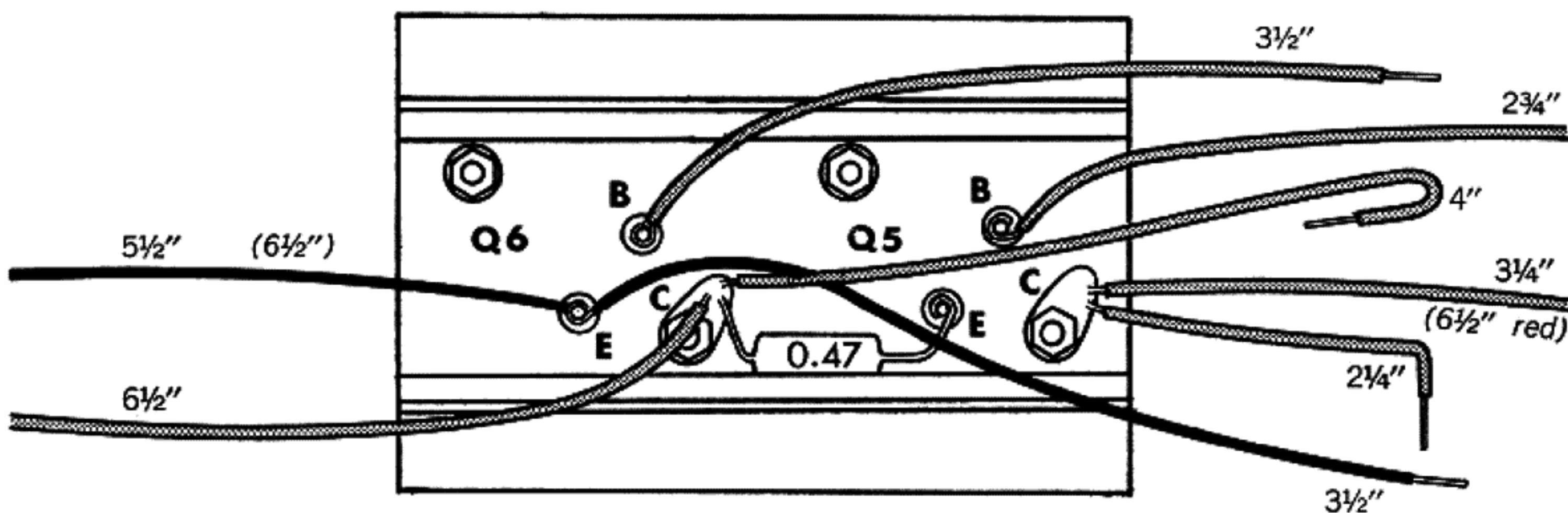

Detail B

- 37() Select the long black wire which protrudes from the bottom of *each* heat sink (from Q6E). Connect these two wires to one of the ground lugs at the power supply board. Soldering of wires to these lugs will be easier if they are all *brought up through the lug from underneath*.
- 38() Connect the green wire protruding from the bottom of the left heat sink to eyelet #4 of PC-19. (S).
- 39() Connect the red wire protruding from the bottom of the right heat sink to eyelet #3 of PC-19. (S).

Select both of the PC-18 amplifier boards. Be particularly careful handling these boards, for they represent a substantial portion of the cost of the SCA-80Q. The transistors stand upright on the boards, held in place by their leads. Careless handling can unduly flex and possibly break the leads. In addition, the same silicon compound you used in mounting the output transistors is also already applied between the driver transistors, Q3 and Q4, and their smaller heat sinks on the boards.

Make sure each of the 4 transistors on each board is standing up so that their leads do not touch one another. There should be no need for you to solder to any of the components, since all connections will be made to eyelets along the top edge of the board. However, if the occasion arises, remember that excessive heat will damage any transistor, though these are rugged silicon types. When soldering to a transistor lead, it is important that the iron and the junction be hot enough when you apply the solder, so that the solder will flow rapidly into the junction. Then you can remove the iron quickly and allow the connection to cool.

Be careful that no solder splashes onto the circuitry where it may cause a short circuit and damage the amplifier. Only a small amount of solder is usually needed on any connection.

The instructions will refer to the *front* or *rear amplifier (PC-18)* or *preamplifier (PC-17)* circuit boards, as well as to inserting the wire from the *forward* side or *back* side of each board. *Forward* refers to the side nearest the front of the chassis. The forward and back designations will be in parentheses.

- 40() On each of the PC-18 boards you will note two unused holes below eyelets 11 and 12. Select two 10,000 ohm (brown-black-orange) resistors and trim their leads to $\frac{1}{2}$ ". Bend the leads in a "U", and install one of these resistors on each circuit board through these holes. Heat the circuitry on the opposite side with the iron to melt the solder while you push the leads through the board. Mount the resistor flush to the board, and cut off the excess leads. Be sure the connections are well soldered.
- 41() The PC-18 boards slide into the pairs of "C" shaped channels on the heat sinks, resting on the mounting screws at the bottom. Orient one of the boards with the eyelets uppermost, with the components toward the front of the chassis, and the circuit side toward the power supply board. Slide it into the *front* pair of channels.

- 42() Connect the red wire from eyelet #5 of PC-19 to eyelet #6 (back) of PC-18. (S).
- 43() Connect the shorter black wire from Q6E of the right heat sink to eyelet #2 of PC-18. (S).
- 44() Connect the *hooked red* wire from Q6C to eyelet #8 of PC-18. (S).
- 45() Connect the red wire protruding the shortest distance above the heat sink (from Q6B at the bottom of the heat sink) to eyelet #3 of PC-18. (S).
- 46() Connect the red wire with the right-angle bend (from lug Q5C) to eyelet #4 of PC-18. (S).
- 47() Connect the remaining shorter red wire (from Q5B) to eyelet #5 of PC-18. (S).
- 48() Install the other PC-18 board in the rear pair of channels with the eyelets up, and the components side facing to the *rear*. Note that while the pre-amplifier boards were installed facing the same way, the amplifier boards face in opposite directions.

The following 6 steps all refer to connections to be made to the *rear* PC-18.

- 49() Connect the green wire from eyelet 6 of PC-19 to eyelet #6 (back) of PC-18. (S).
- 50() Connect the shorter black wire from Q6E of the left heat sink to eyelet #2. (S).
- 51() Connect the hooked green wire from Q6C of the heat sink to eyelet #8. (S).
- 52() Connect the green wire protruding the shortest distance above the heat sink (from Q6B) to eyelet #3. (S).
- 53() Connect the green wire with the right-angle bend (from lug Q5C) to eyelet #4. (S).
- 54() Connect the shorter of the two remaining green wires (from Q5B) to eyelet #5. (S).
- 55() Install one of the large 5000 mfd capacitors in position C9 at the rear of the chassis. Seat it firmly to the chassis with the red lug to the front and tighten the bracket clamp.
- 56() Connect the long red wire from lug Q5C of the right heat sink to the red lug of C9. Position the wire over towards the left heat sink, and then back to C9.

Now turn to page 19.

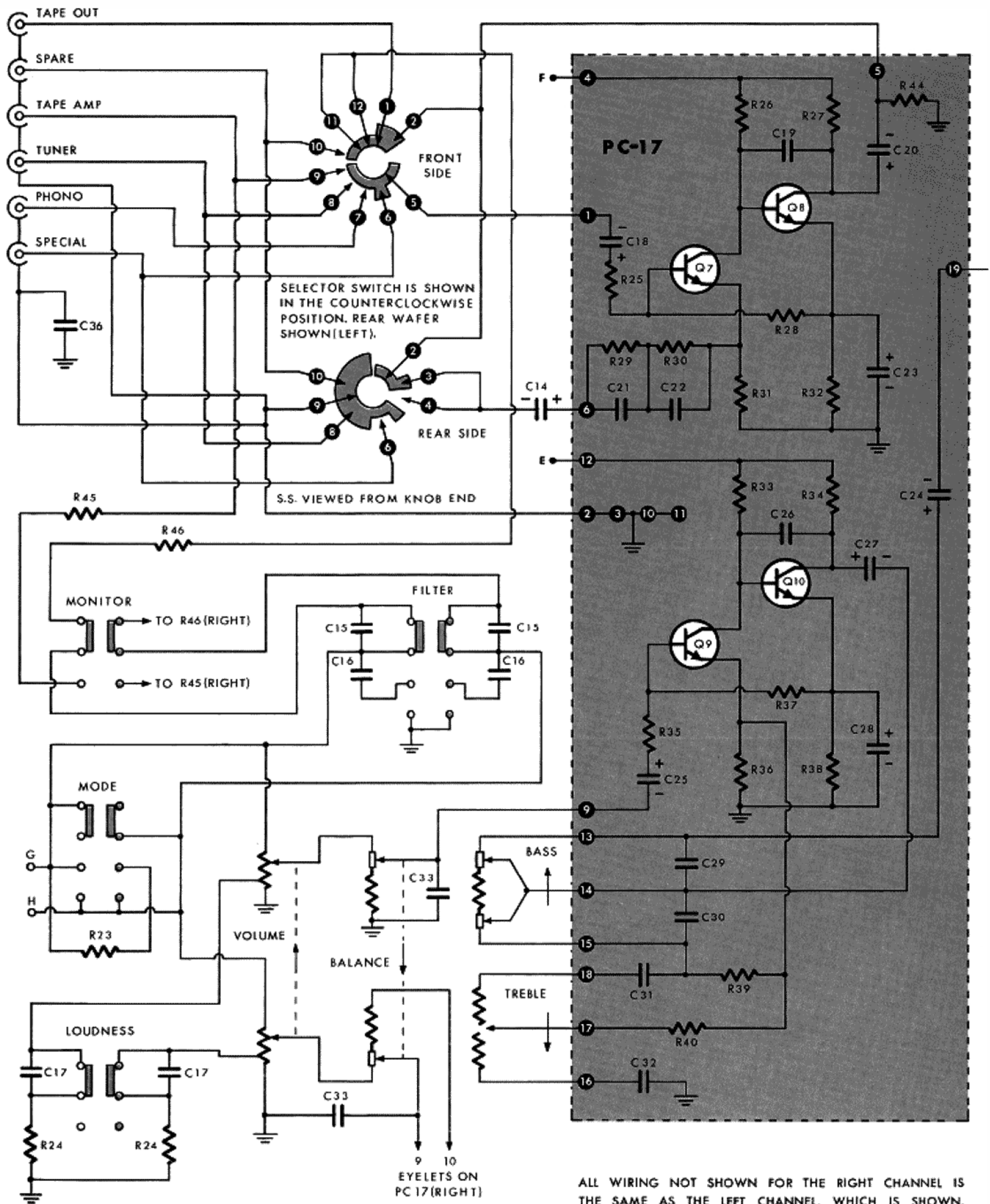

ALL WIRING NOT SHOWN FOR THE RIGHT CHANNEL IS THE SAME AS THE LEFT CHANNEL, WHICH IS SHOWN. RESISTOR AND CAPACITOR NUMBERS ARE THE SAME FOR THE PARTS ON BOTH CHANNELS.

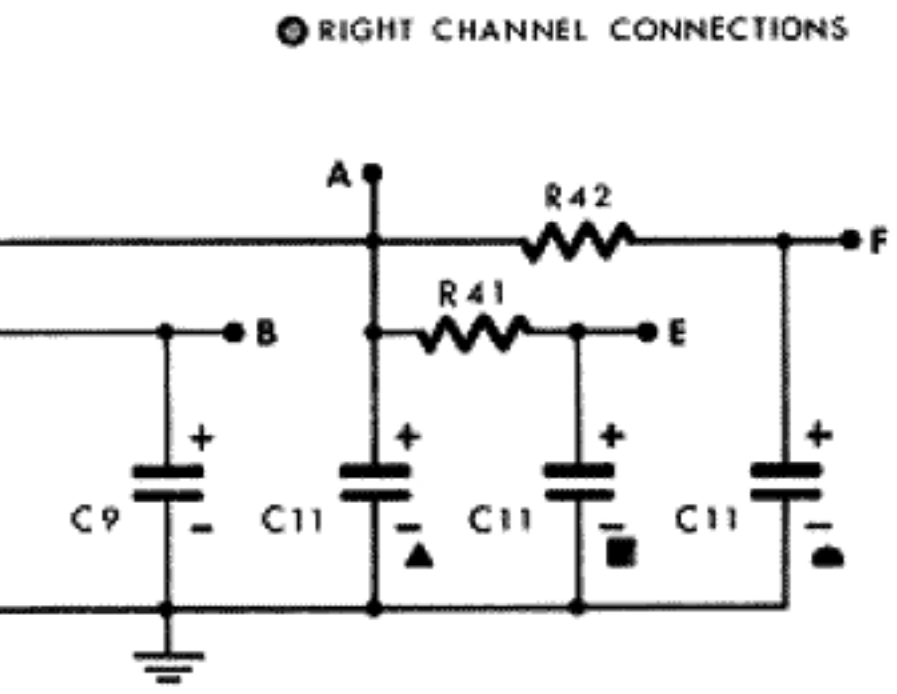
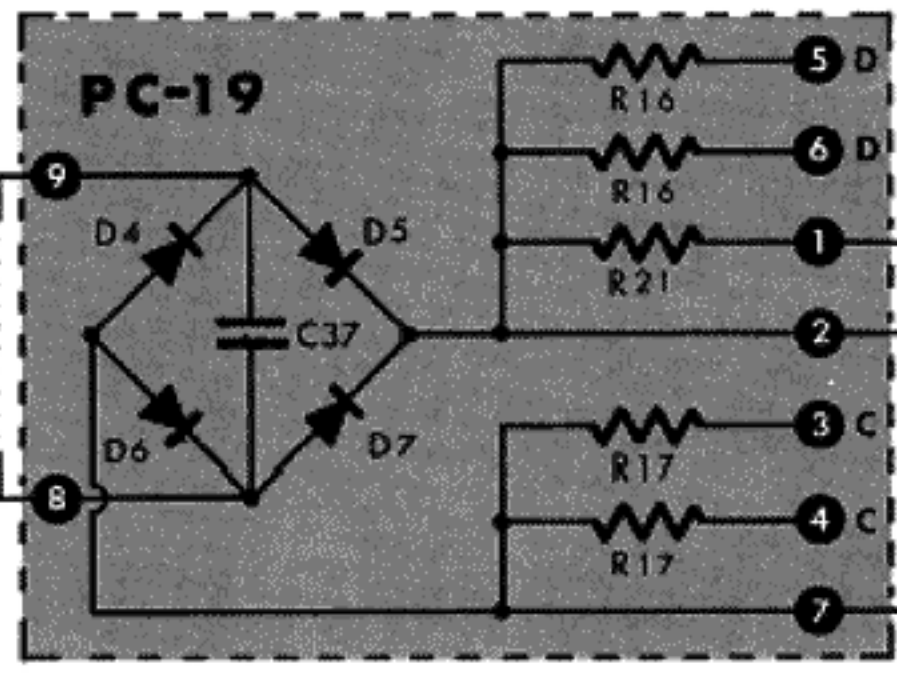
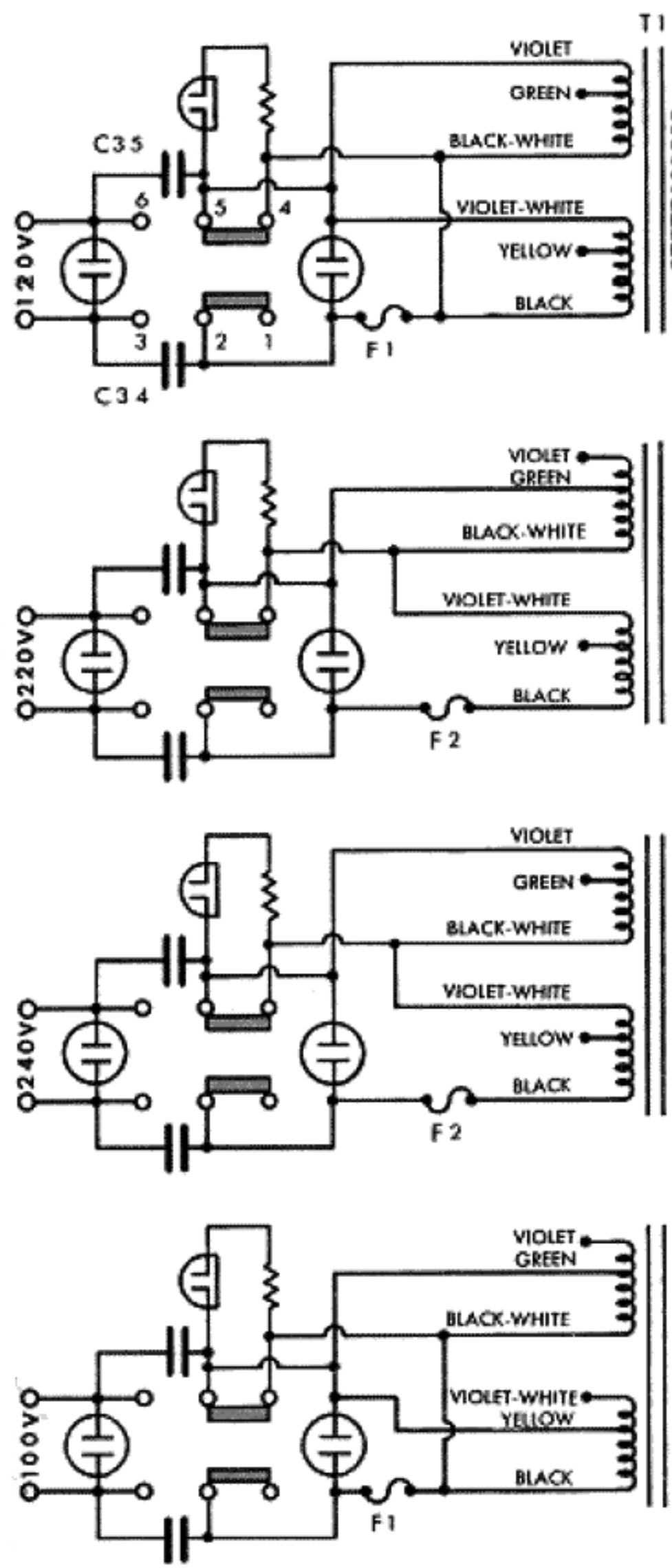
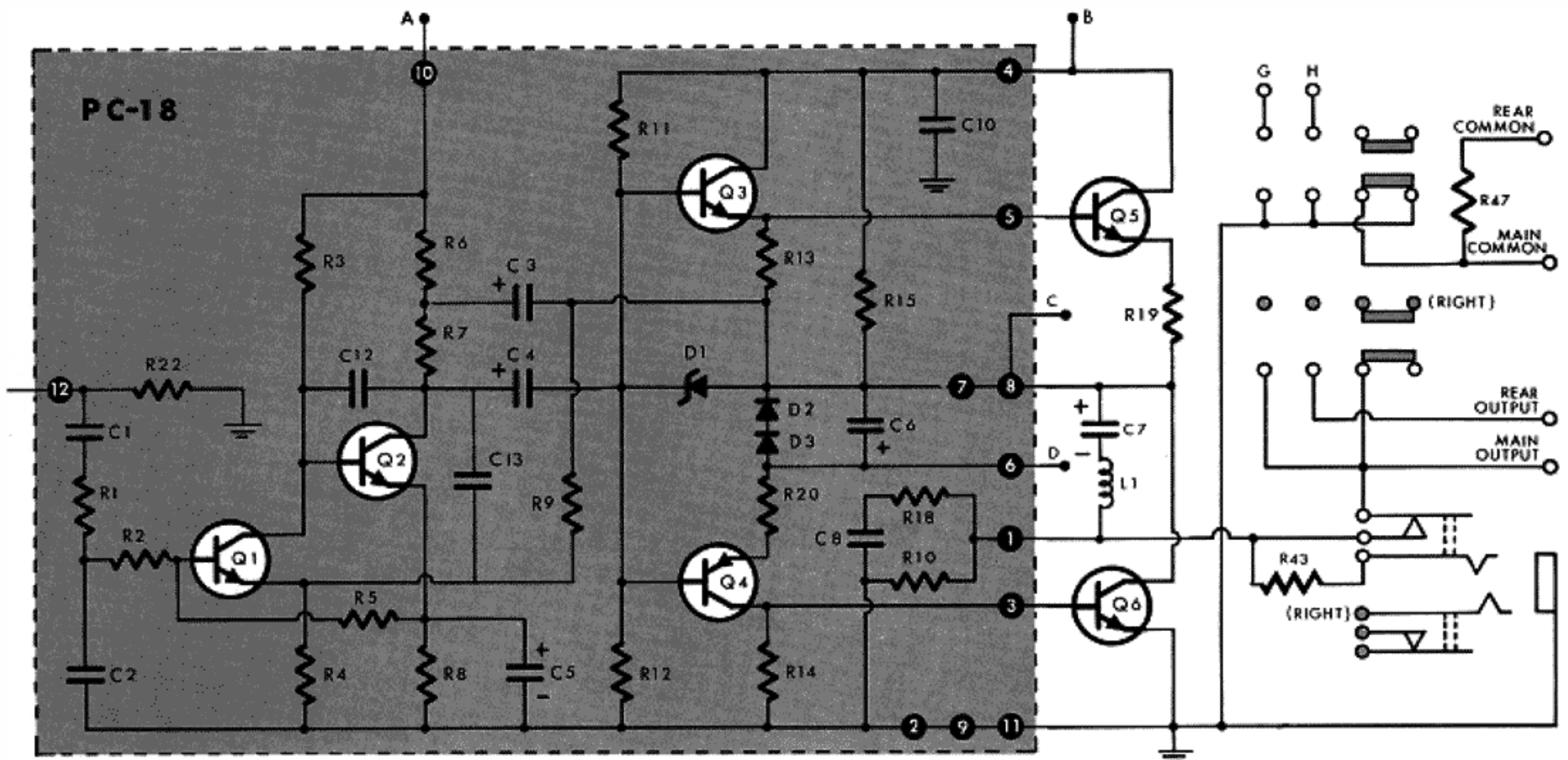

VOLTAGE TEST POINTS

Measured with VTVM (TVM) at rated AC line voltage, 8 ohm load, shorted input. All voltages are DC unless specified AC. Voltages not shown are not significant for servicing purposes, as they may vary widely with different transistors and still be normal. Transistor lead voltages shown may vary $\pm 20\%$ or more. Other points should be within $\pm 10\%$.

PC-18	PC-19	Q7	Q8	Q9	Q10
#1 0	#1 71	E .1	.8	.3	1.2
#2 0	#2 74	B .7	1.5	.94	1.8
#3 <0.5	#3 36	C 1.5	10	1.8	9.4
#4 74	#4 36				
#5 36.5	#5 37.5				
#6 37.5	#6 37.5				
#7 36	#7 0				
#8 36	#8 } 54 AC*				
#9 0	#9 }				
#10 71					
#11 0					
#12 0					

Capacitor C-11

- ▲ 71
- 24
- ◐ 17.5

SCHEMATIC DIAGRAM

COMPONENT VALUES

All resistors are 1/2 watt, 5% unless otherwise indicated.

		PART #			PART #			PART #
R 1	4,700 ohms	113472	R30	56,000 ohms	113563	C11	700 mfd @ 75v.	▲
R 2	4,700 ohms	113472	R31	120 ohms	113121		700 mfd @ 60v.	■
R 3	30,000 ohms	113303	R32	330 ohms	113331		800 mfd @ 20v.	●
R 4	150 ohms	113151	R33	33,000 ohms	113333	C13	27 pf	294228
R 5	100,000 ohms	113104	R34	3,300 ohms	113332	C14	5 mfd, 15v.	244271
R 6	1,000 ohms	113102	R35	4,700 ohms	113472	C15	0.01 mfd, 5%	283505
R 7	1,500 ohms	113152	R36	390 ohms	113391	C16	3300 pf, 5%	265103
R 8	330 ohms	113331	R37	120,000 ohms	113124	C17	0.022 mfd	265332
R 9	2,200 ohms, 1 watt	116222	R38	270 ohms	113271	C18	5 mfd, 15v.	265223
R10	1,000 ohms	113102	R39	4,700 ohms	113472	C19	100 pf, 5%	283505
R11	10,000 ohms	113103	R40	68 ohms, 10%	112680	C20	50 mfd, 25v.	245101
R12	10,000 ohms	113103	R41	4,700 ohms	113472	C21	0.015 mfd, 5%	283516
R13	68 ohms	103680	R42	10,000 ohms	113103	C22	0.056 mfd, 5%	265153
R14	68 ohms	103680	R43	120 ohms	113121	C23	100 mfd, 2v.	265563
R15	2,200 ohms, 1 watt	116222	R44	47,000 ohms	113473	C24	50 mfd, 25v.	281107
R16	400 ohms, 7 watt, 5%	120401	R45	10,000 ohms	113103	C25	0.33 mfd	283516
R17	400 ohms, 7 watt, 5%	120401	R46	10,000 ohms	113103	C26	220 pf	263334
R18	4.7 ohms, 1 watt, 10%	125040	R47	10 ohms, 10 watt, 10%	120100	C27	50 mfd, 25v.	245221
R19	0.47 ohms, 2 watt, 10%	128004	C 1	0.33 mfd	263334	C28	500 mfd, 2v.	283516
R20	3.3 ohms	103030	C 2	220 pf	245221	C29	0.068 mfd	281507
R21	68 ohms	103680	C 3	35 mfd, 30v., non-pol	283366	C30	0.1 mfd, 5%	265683
R22	10,000 ohms	113103	C 4	35 mfd, 30v., non-pol.	283366	C31	0.015 mfd, 5%	269104
R23	8,200 ohms	113822	C 5	500 mfd, 15v.	283507	C32	0.22 mfd	265153
R24	18,000 ohms	113183	C 6	0.47 mfd, 100v., non-pol.	264474	C33	27 pf	265224
R25	4,700 ohms	113472	C 7	5000 mfd, 80v.	284508	C34	0.02 mfd	244271
R26	33,000 ohms	113333	C 8	0.1 mfd, 100v.	264104	C35	0.02 mfd	227203
R27	3,300 ohms	113332	C 9	5000 mfd, 80v.	284508	C36	0.01 mfd	227203
R28	47,000 ohms	113473	C10	0.01 mfd, 100v.	244104	C37	0.01 mfd disc, 500v.	244104
R29	4,700 ohms	113472	C12	68 pf	237680			228103

		PART #
F 1	Fuse, 2 amp slo-blo	342020
F 2	Fuse, 1 amp slo-blo (alternate)	342010
L 1	114 inches of #16 insulated wire	319913
T 1	Dynaco power transformer 10490E	464019
D 1	zener diode, 5.1 volt, 5%, 400 mw	540405
D 2	silicon diode, 0.8 volt max. drop @ 140 ma.	544015
D 3	silicon diode, 0.8 volt max. drop @ 140 ma.	544015
D 4	silicon diode, 3 amperes, 200 prv.	544322
D 5	silicon diode, 3 amperes, 200 prv.	544322
D 6	silicon diode, 3 amperes, 200 prv.	544322
D 7	silicon diode, 3 amperes, 200 prv.	544322
Q 1	BC108A 170-260 Beta @ 2 ma	572108
Q 2	2N5320 140-260 Beta, 90 V, r=5KΩ @ 50 ma	572002
Q 3	TIP31C	577031
Q 4	TIP32C	567032
Q 5	2N3772/571844, 40-90 Beta @ 1 A	338-1
Q 6	2N3772/571844 Red Dot, 60-90 Beta @ 1 A	338-2
Q 7	BC109B 240-500 Beta @ 5 volts, 2 ma	572109
Q 8	BC109B 240-500 Beta @ 5 volts, 2 ma	572109
Q 9	BC109B 240-500 Beta @ 5 volts, 2 ma	572109
Q 10	BC109B 240-500 Beta @ 5 volts, 2 ma	572109

		PART #
Volume control	250,000 ohms tapped	177254
Balance control	220,000 ohms special	167224
Bass control	50,000 ohms special	167514
Treble control	40,000 ohms special	167404

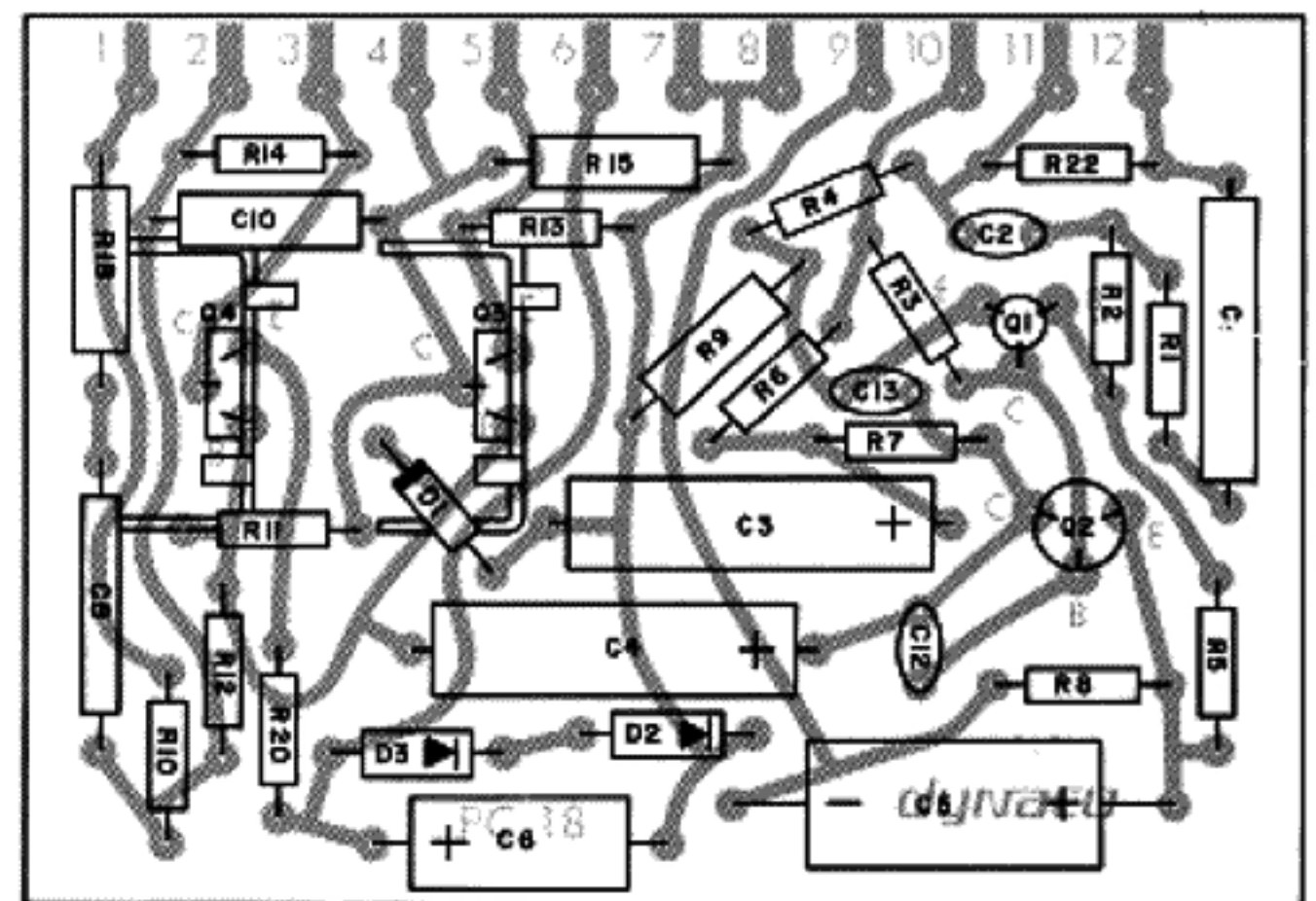

PC-18

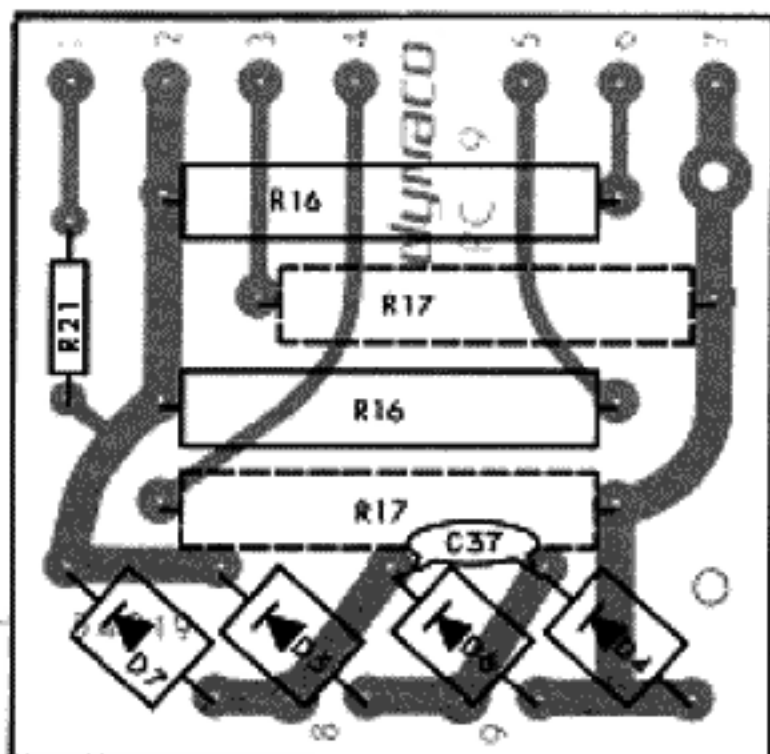

PC-19

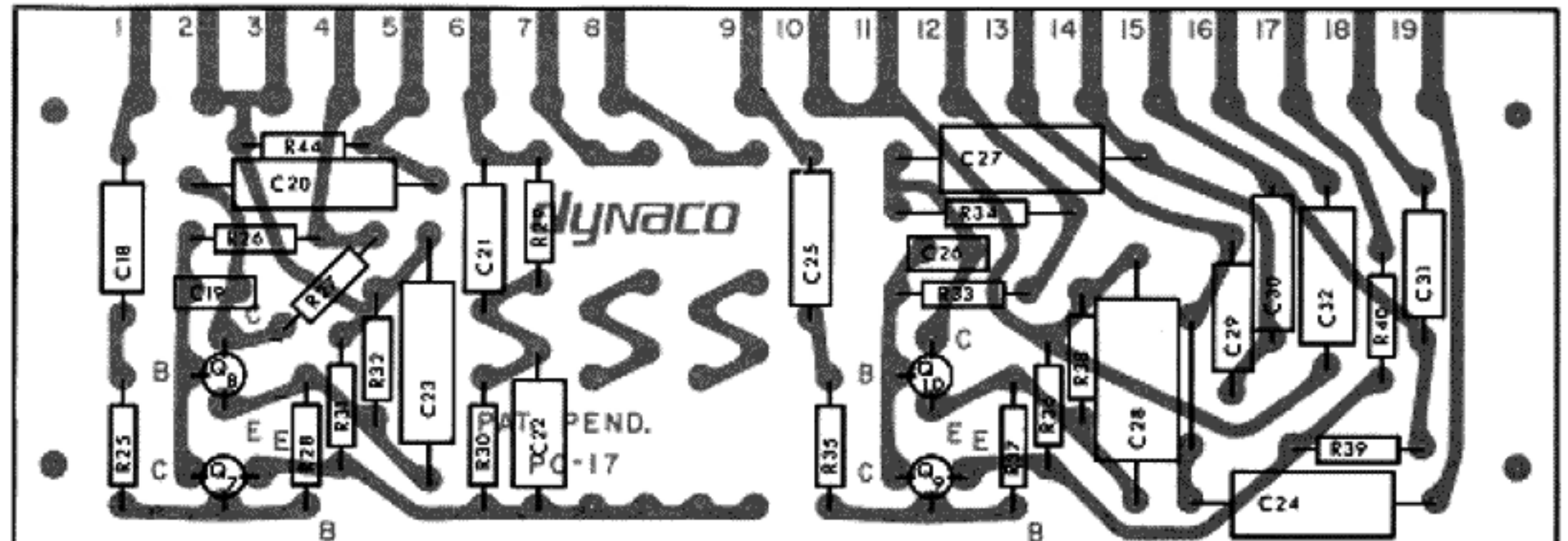

PC-17

- 57() Connect the green wire from lug Q5C of the left heat sink to the red lug of C9.
- 58() Prepare a 3 $\frac{1}{4}$ " red wire. Tin one end and connect it to eyelet #2 (forward) of the power supply board. (S). Connect the other end to the red lug of C9. (S-3).
- 59() Prepare a 5" length of the *heavy gauge* wire. Connect one end to the black lug of C9. (S). Connect the other end to one of the ground lugs at PC-19, bending it up from underneath.
- 60() Each of the two coils of heavy gauge wire will be formed into a coil around one of the large C7 5000 mfd capacitors. To facilitate forming these coils, you will use the *smaller* capacitor C11 (3-section electrolytic) as a form. Strip $\frac{1}{4}$ " of insulation from one end of the coil, and form a small hook at that end. Hook the wire around one of the outside ground lugs of C11, bring it across the capacitor past the opposite ground lug and bend it sharply down over the rim of the capacitor. About $\frac{1}{4}$ " below the rim, bend it sharply to the right to start the wire in a *counter-clockwise* direction when looking at the top (lug end) of the capacitor. Wind the wire tightly with the turns as close together as possible for at least 24 turns. Do not cut off the remaining wire. You must hold the "start" while you wind, and feed the wire by *unwinding* the coil supplied. You may find it easier if you place the capacitor inside the supplied coil while you form the new coil. Pulling the wire straight off the coil may cause it to kink. This is the most tedious part of the kit. Take the time to do a good job.



When you release your hold, the wire will spring loose to form a larger diameter coil. Disengage the hook from the lug and slide the coil off C11. Select one of the larger 5000 mfd capacitors and fit its lug end into the part of the formed coil that is farthest from its hooked end. Guide the coil onto the capacitor a loop at a time, as though you were threading it on. With care and patience you can avoid deforming the coil and keep it snug. When the coil is all on the capacitor, slide it around until the hook will fasten through the black lug after passing behind the red lug, and solder the black lug. (S).

- 61() Form a second coil exactly as before. Install this coil on the remaining 5000 mfd capacitor, and solder the hook to the black lug. (S).

- 62() Select one of the capacitors with the coil wound around it, count 17 complete turns, and install it with the *red lug to the front* in position C7L next to the power transformer. At this time the position of the lugs is rotated 90° from its final position as shown in the pictorial diagram. Tighten the bracket clamp to secure the capacitor, make sure the coil is snug and tightly wound, and measure 3" of wire protruding *past the side edge* of the chassis. Cut off the excess. Strip $\frac{1}{4}$ " of insulation from the end, and hook the end over the chassis to secure it temporarily.
- 63() Install the other capacitor and coil in position C7R with the red lug to the front, count 17 full tight turns and only $\frac{1}{2}$ " of wire protruding past the side edge. Cut off the excess, strip $\frac{1}{4}$ " of insulation from the end, and hook it over the clamp to secure it.
- 64() Install the 3-section capacitor C11 in its bracket at the left of the chassis. Seat it firmly to the chassis with the lugs oriented as in the diagram, and tighten the bracket clamp.

In four of the next five steps a wire is called for which has extra insulation removed from one end. This longer bared end is to be connected to correspondingly numbered eyelets in the *front* and *rear preamplifier* boards. First push it through the rear board from the back, and then heat the eyelet on the front board as you push the tip of the wire through the eyelet and solder it in place. Then apply solder to the rear board to solder that eyelet.

- 65() Prepare a 3 $\frac{3}{4}$ " black wire with 1 $\frac{1}{2}$ " of insulation removed from one end. Connect it to eyelet #3 of each PC-17 board. (S). Connect the other end to ground lug D of C11.
- 66() Prepare a 6 $\frac{3}{4}$ " black wire with 1 $\frac{1}{2}$ " of insulation removed from one end. Connect it to eyelet #11 of each PC-17 board. (S). Connect the other end to ground lug D of C11. (S-2).
- 67() Prepare a 4 $\frac{3}{4}$ " red wire with 1 $\frac{1}{2}$ " of insulation removed from one end. Connect it to eyelet #4 of each PC-17 board. (S). Connect the other end to lug C (semi-circle) of C11.
- 68() Select a 10,000 ohm resistor (brown-black-orange), and trim the leads to no more than $\frac{3}{4}$ ". Connect one end to lug C (semi-circle) of C11. (S-2). Connect the other end to lug A (triangle) of C11.
- 69() Prepare a 7 $\frac{3}{4}$ " red wire with 1 $\frac{1}{2}$ " of insulation removed from one end. Connect it to eyelet #12 of each PC-17 board. (S). Connect the other end to lug B (square) of C11.
- 70() Select a 4700 ohm resistor (yellow-violet-red) and trim the leads to no more than $\frac{3}{4}$ ". Connect one end to lug B (square) of C11. (S-2). Connect the other end to lug A (triangle) of C11.
- 71() Prepare a 3 $\frac{1}{2}$ " black wire. Tin one end and connect it to eyelet #11 (forward) of the front *amplifier* board PC-18. (S). Connect the other end to ground lug E of C11.

- 72() Prepare a 4" black wire. Tin one end and connect it to eyelet #9 (forward) of the front PC-18. (S). Connect the other end to ground lug E of C11.
- 73() Prepare a 6 $\frac{3}{4}$ " black wire. Tin one end and connect it to eyelet #9 (forward) of the rear PC-18. (S). Connect the other end to ground lug E of C11.
- 74() Prepare a 7 $\frac{1}{2}$ " black wire. Tin one end and connect it to eyelet #11 (forward) of the rear PC-18. (S). Connect the other end to ground lug E of C11. (S-4). Be sure all of these wires are soldered.
- 75() Prepare a 4 $\frac{1}{4}$ " red wire. Tin one end and connect it to eyelet #10 (forward) of the front PC-18. (S). Connect the other end to lug A (triangle) of C11.

- 76() Prepare a 7 $\frac{1}{2}$ " green wire. Tin one end and connect it to eyelet #10 (forward) of the rear PC-18. (S). Connect the other end to lug A (triangle) of C11.
- 77() Prepare an 8" red wire. Tin one end and connect it to eyelet #1 (forward) of the power supply board PC-19. (S). Connect the other end to lug A (triangle) of C11. (S-5). Be sure all these wires are soldered.

Your SCA-80Q is now nearly half completed. The chassis should look much like the accompanying photograph. Set it aside for the present, and place the front panel before you.

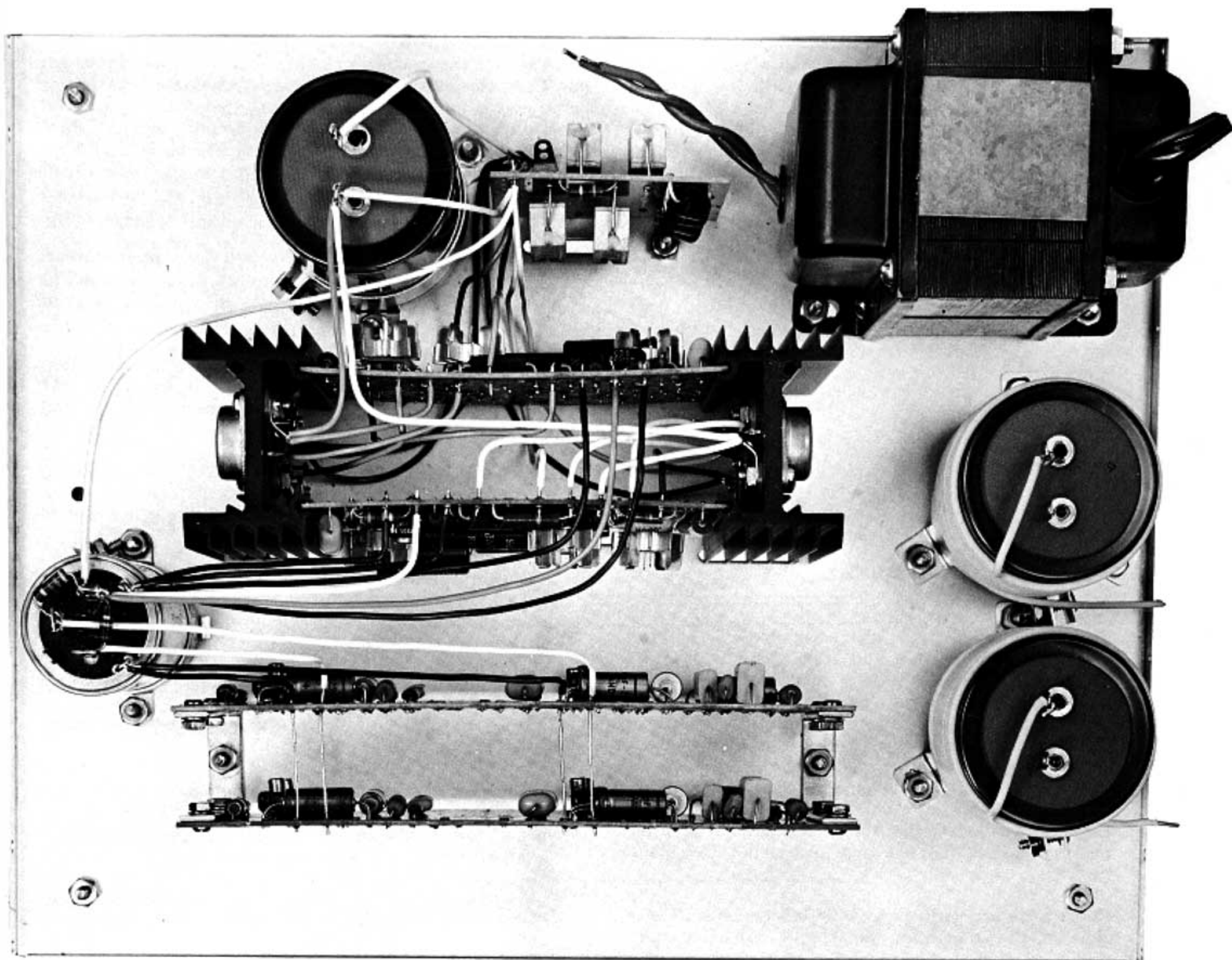

Wiring the Front Panel

Note that lugs on the controls (with the exception of the selector switch) are numbered in a clockwise direction when viewing the back of the control, and the right channel (red wires) is nearest the panel, and has the low lug numbers. The upper rows of lugs on the rocker switches (with the exception of MS) are for the left channel. In general you should try to keep components and wires which connect to the upper lugs above the switches, and those to the lower row below the switches. Keep green wires separated from red wires and cross them at right angles when necessary, to maintain maximum channel separation. Keep component leads *short* so that they will not interfere with the front preamplifier board when the panel is assembled to the main chassis. To enable you to trace wires on the pictorial diagram, some distortion of wire placement is necessary, so you should use the photograph of the front panel on the next page as a guide.

- 1() Prepare a 1 $\frac{1}{4}$ " red wire. Connect one end to BC lug #3. (S). Connect the other end to VC lug #2. (S).
- 2() Prepare a 2" red wire. Connect one end to VC lug #7. (S). Connect the other end to LS lug #6.
- 3() Select a .022 mfd capacitor and trim its leads to no more than $\frac{3}{4}$ ". Connect one end to LS lug #6. (S-2). Connect the other end to LS lug #5.
- 4() Select an 18,000 ohm resistor (brown-gray-orange). Connect one end to VC lug #1. Make sure it is clear of other switch lugs, and connect the other end to LS lug #5, trimming it as needed. (S-2).
- 5() Prepare a 3" black wire, but strip $\frac{1}{2}$ " of insulation from one end. Feed the longer bared end through FS lug #1 from the top and connect it to FS lug #5. (S). Now solder lug #1 also. (S). Connect the other end to VC lug #1.
- 6() Prepare a 1 $\frac{3}{4}$ " black wire. Connect one end to VC lug #1. (S-3). Connect the other end to BC lug #1.
- 7() Select a 27 pf disc capacitor. Connect one lead to BC lug #2. Connect the other lead to BC lug #1.
- 8() Prepare a 3" red wire. Connect one end to BC lug #2. (S-2).
- 9() Prepare a 3" black wire. Connect one end to BC lug #1. (S-3). Position this wire past the top of the panel, along with the red wire from the previous step, and twist them together except for $\frac{1}{2}$ " at the free ends.
- 10() Prepare a 1 $\frac{1}{2}$ " green wire. Connect one end to BC lug #4. (S). Connect the other end to VC lug #5. (S).
- 11() Prepare another 1 $\frac{1}{2}$ " green wire. Connect one end to VC lug #8. (S). Connect the other end to LS lug #3.
- 12() Select the remaining .022 mfd capacitor. Trim its leads to no more than $\frac{3}{4}$ " and connect one end to LS lug #3. (S-2). Connect the other end to LS lug #2.
- 13() Select the remaining 18,000 ohm resistor (brown-gray-orange). Connect one end to VC lug #4. Connect the other end to LS lug #2. (S-2).
- 14() Prepare a 1 $\frac{1}{4}$ " black wire. Connect one end to VC lug #4. (S-2). Connect the other end to BC lug #6.
- 15() Select the remaining 27 pf disc capacitor. Connect one end to BC lug #5. Connect the other end to BC lug #6.
- 16() Prepare a 3 $\frac{1}{2}$ " green wire and a 3 $\frac{1}{2}$ " black wire. Twist these together except for $\frac{1}{2}$ " at each end. Connect one end of the green wire to BC lug #5. (S-2). Connect the corresponding end of the black wire to BC lug #6. (S-3).
- 17() Prepare a 6" red wire. Connect one end to MS lug #2. (S). Connect the other end to FS lug #8. Place this wire close to the panel and under LS, routing it as shown in the front panel photograph.
- 18() Select a .01 mfd *non-disc* capacitor. The disc capacitors are used elsewhere. Trim the leads to no more than $\frac{3}{4}$ " and connect one end to FS lug #7. Connect the other end to FS lug #8. (S-2).
- 19() Select a 3300 pf (.0033 mfd) capacitor, trim the leads to no more than $\frac{3}{4}$ " and connect one end to FS lug #6. (S). Connect the other end to FS lug #7.
- 20() Prepare a 4" red wire, but strip $\frac{3}{4}$ " of insulation from one end. Feed the longer bared end through BS lug #7 from the *bottom* and across through the center of the switch to connect to BS lug #5. Keep the bare wire clear of adjacent lugs, and solder only BS lug #7 now. (S). Connect the other end to FS lug #7. (S-3).
- 21() Prepare another 4" red wire. Connect one end to OS lug #13. (S). Position this wire below the switch and against the panel, and connect it to BS lug #5.
- 22() Prepare a 6 $\frac{1}{2}$ " red wire, but strip $\frac{1}{2}$ " of insulation from one end. Feed the longer bared end through BS lug #1 from the *top*, and connect it to BS lug #5. (S-3). Now also solder lug #1. (S). Keep this wire close to the panel and above control BC, and connect the other end to VC lug #3. (S).
- 23() Prepare a 4 $\frac{3}{4}$ " green wire. Connect one end to MS lug #5. (S). Connect the other end to FS lug #4. Place this wire along the top row of lugs and to the rear of LS, away from the red wires which should be crossed at right angles.
- 24() Select the remaining .01 mfd *non-disc* capacitor, and trim its leads to no more than $\frac{3}{4}$ ". Connect one end to FS lug #3. Connect the other end to FS lug #4. (S-2).
- 25() Select the remaining 3300 pf capacitor, and trim its leads to no more than $\frac{3}{4}$ ". Connect one end to FS lug #2. (S). Connect the other end to FS lug #3.
- 26() Prepare a 3 $\frac{1}{4}$ " green wire, but strip $\frac{3}{4}$ " of insulation from one end. Feed the longer bared end through BS lug #4 from the *bottom*, and across the top of the switch to connect to BS lug #2. Connect the other end to FS lug #3. (S-3).

- 27() Prepare a 4 $\frac{1}{4}$ " green wire. Connect one end to VC lug #6. (S). Connect the other end to BS lug #4. (S-3. One through wire=2).
- 28() Prepare a 4" green wire. Connect one end to OS lug #14. (S). Tuck this wire under the switch and against the panel, and connect the other end to BS lug #2. Keep this wire at least $\frac{1}{2}$ " away from the red wire to OS wherever possible.
- 29() Select the 8200 ohm resistor (gray-red-red). Trim its leads to $\frac{1}{2}$ ", and connect one end to BS lug #6. (S). Connect the other end to BS lug #2. (S-3). Do not allow the resistor leads to touch the bare wire between lugs 5 and 7 of the switch.
- 30() Prepare three red wires each 3 $\frac{1}{4}$ " long. Connect these, and the following three red wires so that they point toward control BC as they come off the lugs to which they are soldered. Connect the first wire to DT lug #3. (S). Connect the second to DT lug #2. (S). Connect the third to DT lug #1. (S).
- 31() Prepare a 2 $\frac{1}{2}$ " red wire. Connect it to DB lug #3. (S).
- 32() Prepare two 3" red wires. Connect the first to DB lug #2. (S). Connect the second to DB lug #1. (S).
- 33() Prepare three 3 $\frac{1}{2}$ " green wires. Connect the first to DT lug #4. (S). Connect the second to DT lug #5. (S). Connect the third to DT lug #6. (S).
- 34() Prepare three 3" green wires. Connect the first to DB lug #4. (S). Connect the second to DB lug #5. (S). Connect the third to DB lug #6. (S).
- 35() Select a 120 ohm resistor (brown-red-brown), and trim its leads to no more than $\frac{1}{2}$ ". Connect one lead to HP lug #5. (S). Connect the other lead to HP lug #6. If the resistor is placed against the jack, between the lugs, it will facilitate connecting additional wires later.
- 36() Select the remaining 120 ohm resistor (brown-red-brown), and trim its leads to no more than $\frac{1}{2}$ ". Connect one lead to HP lug #3. (S). Connect the other lead to HP lug #2.
- 37() Prepare a 1 $\frac{1}{2}$ " red wire, but strip $\frac{3}{4}$ " of insulation from one end. Feed the longer bared end through OS lug #5 from the top and through the center of the switch to connect to OS lug #7. Solder both lugs, making sure the wire is clear of adjacent lugs. Connect the other end to HP lug #7.
- 38() Prepare a 12" red wire. Connect one end to HP lug #7. (S-2).

As long wires will be connected to the front panel in some of the following steps, be particularly careful of your eyes when working on it. Also be careful that the lugs to which these wires are connected are not distorted or allowed to touch adjacent lugs through careless handling.

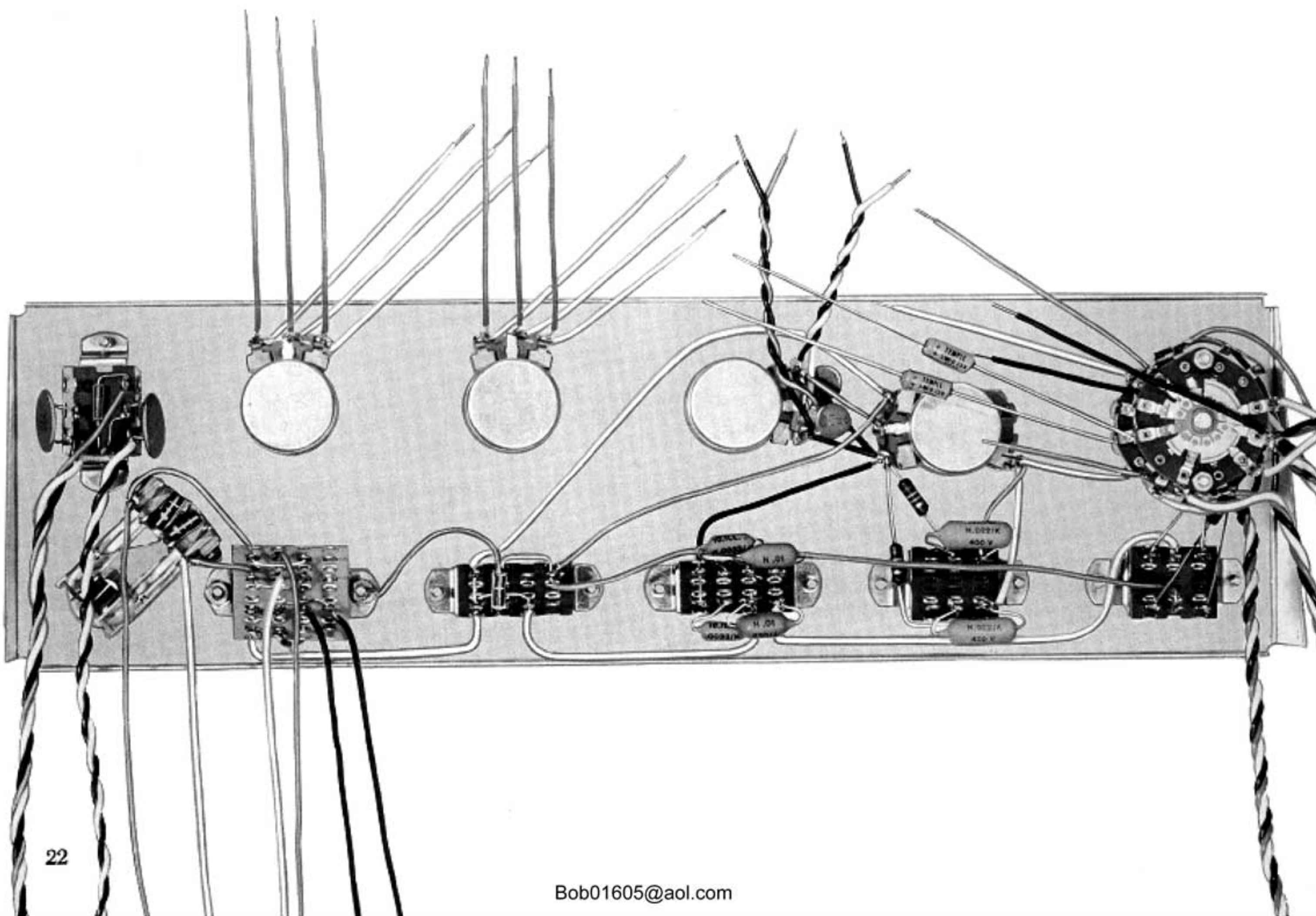

- 39() Prepare a 3" green wire, but strip $\frac{3}{4}$ " of insulation from one end. Feed the longer bared end through OS lug #1 from the *top*, and connect it to OS lug #3. *Solder both lugs*, making sure the wire is clear of adjacent lugs. Position the wire over the top of the headphone jack, and connect the other end to HP lug #1.
- 40() Prepare a 12" green wire. Connect one end to HP lug #1. (S-2).
- 41() Prepare a 12" black wire, but strip 1" of insulation from one end. Feed the longer bared end through OS lug #12 from the *bottom*, through the center of the switch, and through OS lug #10 from the *top*, and finally over to OS lug #9. *Solder all three lugs*, keeping the wire clear of lug #11. Bend a hook in the far end of this wire for later identification.
- 42() Prepare an 11" black wire. Connect one end to OS lug #11. (S).
- 43() Prepare a 12" red wire. Connect one end to OS lug #6. (S). Bend a hook in the far end of this wire for later identification.
- 44() Prepare an 11 $\frac{1}{2}$ " green wire. Connect one end to OS lug #2. (S). Bend a hook in the far end of this wire for later identification.
- 45() Select one of the .02 mfd disc capacitors. Trim each lead to $\frac{3}{4}$ ", and slide a $\frac{1}{2}$ " piece of insulating sleeving over each lead. Connect one lead to PS lug #2, and the other to PS lug #3.
- 46() Select the remaining .02 capacitor. Trim its leads to $\frac{3}{4}$ ", and slide a $\frac{1}{2}$ " piece of insulating sleeving over each lead. Connect one lead to PS lug #5, and the other to PS lug #6. Place both capacitors alongside the switch frame, one on each side.
- 47() Prepare four wires each 17" long: two blacks and two reds. Connect one end of each of them to switch PS as follows: A red wire to lug #3. (S-2). A black wire to lug #2. (S-2). A red wire to lug #6. (S-2). A black wire to lug #5. (S-2).
- 48() Prepare an 18" green wire. Connect one end to PS lug #4. (S).
- 49() Twist together the green wire from PS lug 4 with the black wire from lug 2 and the red wire from lug 3 throughout their length except for one inch at the free end. Twist them uniformly, so they remain nearly equal in length.
- 50() Twist together the black wire from PS lug 5 and the red wire from lug 6 except for one inch at the free end.

You will next wire the selector switch. Be very careful of this, for the phenolic wafers are relatively delicate, and you must be careful that the long wires do not put undue stress on them. Be careful that you *do not twist the lugs on the rivets which hold them*, as the rotational "timing" of the switch contacts is critical, and twisting the lugs could result in malfunction.

The switch lugs are numbered clockwise starting at the top of the switch, when looking at it from the *front* of the panel. Lug #9 on both wafers (which are identical) has two independent sections. When connections are called for here, they will specify the *forward* or *back* portion of the lug. In *all other* positions where a double lug appears, the two sections are to be soldered together when the connection is made. *Do not allow excess solder or rosin flux to flow down the lugs onto the switch rotor contact area, or malfunction may result.*

- 51() Install the selector switch in location SS. Make sure the locating tab engages the small hole in the front panel and fasten the switch with a $\frac{3}{8}$ " nut.

The next 17 steps refer to wiring the front switch wafer, which is the one nearest the panel.

- 52() Select one of the 10,000 ohm resistors (brown-black-orange) and trim each lead to $\frac{3}{4}$ ". Connect one end to MS lug #1. (S). Connect the other end to SS lug #9 (*forward*), keeping the resistor in front of the switch wafer.
- 53() Select another 10,000 ohm resistor (brown-black-orange). Connect one end to MS lug #3. (S). Keep the resistor in front of the wafer, and connect the other end to SS lug #11.
- 54() Connect a short piece of wire from SS lug #11 to SS lug #12. (S). Also solder lug #11. (S-2).
- 55() Prepare a 3" red wire. Connect one end to SS lug #2. (S). Be sure both lugs are soldered together.
- 56() Select one of the 5 mfd capacitors. Do not trim these leads as nearly their full length will be needed. Note that the positive end is marked with a (+) sign. Feed the lead from the *negative* end through SS lug #4, and connect it to SS lug #3. (S). Also solder lug #4. (S).
- 57() Prepare a 1 $\frac{3}{4}$ " red wire. Connect one end to SS lug #5. (S).
- 58() Prepare an 11 $\frac{1}{2}$ " red wire. Connect one end to SS lug #6. (S). Be sure the two lugs are soldered together. This wire should point toward lug 7 when it is soldered.
- 59() Prepare a 10 $\frac{3}{4}$ " green wire. Connect one end to SS lug #7. (S).
- 60() Prepare an 11 $\frac{1}{2}$ " black wire. Connect one end to SS lug #9 (*back*).
- 61() Carefully twist together the long red, green and black wires from the previous steps throughout their length except for one inch at the free end. This group should come off the side of the switch between lugs 7 and 8. The black wire has not yet been soldered.
- 62() Prepare a 12" red wire. Connect one end to SS lug #8. (S). Solder both lugs together. Push the twisted group toward the panel first, to make it easier to connect this wire, and the next ones. Watch that the lugs are not twisted in the process.

- 63() Prepare a 12½" green wire. Connect one end to SS lug #9 (*forward*). (S-2).
- 64() Prepare a 3¼" black wire. Thread it through the switch *above* the center shaft, and connect one end to SS lug #9 (*back*).
- 65() Prepare a 13" black wire. Connect one end to SS lug #9 (*back*). (S-3).
- 66() Prepare *only one end* of a 13" red wire. Do not remove the insulation from the other end, as this will serve for identification later. Connect the bared end to SS lug #10. (S).
- 67() Prepare *only one end* of a 14½" green wire. Connect the bared end to SS lug #1. (S). This wire should pass lugs 12 and 11 as it is brought around to the side of the wafer.
- 68() Carefully twist together the five long wires from the previous steps throughout their length. This group should come off the switch at lug 9.

The next 17 steps refer to wiring the rear switch wafer.

- 69() Select another of the 10,000 ohm resistors (brown-black-orange). Connect one end to MS lug #6. (S). Connect the other end to SS lug #11.
- 70() Connect a short piece of wire from SS lug #11 to SS lug #12. (S). Also solder lug #11. (S-2).
- 71() Select the remaining 10,000 ohm resistor (brown-black-orange). Connect one end to MS lug #4. (S). Connect the other end to SS lug #9 (*forward*).
- 72() Prepare a 3" green wire. Connect one end to SS lug #2. (S).
- 73() Select the remaining 5 mfd capacitor. Keep the leads full length. Feed the *negative* end through SS lug #4 and connect it to SS lug #3. (S). Also solder lug #4. (S).
- 74() Prepare a 1¾" green wire. Connect one end to SS lug #5. (S).
- 75() Prepare a 9¾" red wire. Connect one end to SS lug #6. (S). This wire should point toward lug 7 when it is soldered.
- 76() Prepare a 9" green wire. Connect one end to SS lug #7. (S).
- 77() Prepare a 9" black wire. Connect one end to SS lug #9 (*back*).
- 78() Carefully twist together the long red, green and black wires throughout their length except for one inch at the free end. This group should come off the side of the switch at lug 8. The black wire is not yet soldered.
- 79() Prepare a 9¼" red wire. Connect one end to SS lug #8. (S). Push the previous group forward to make connection of this wire easier.
- 80() Prepare a 9¾" green wire. Connect one end to SS lug #9 (*forward*). (S-2).

- 81() Prepare a 3¼" black wire. Connect one end to SS lug #9 (*back*). This wire should point toward lug 3.
- 82() Prepare a 10" black wire. Connect one end to SS lug #9 (*back*). (S-3).
- 83() Prepare *only one end* of a 10" red wire. Connect the bared end to SS lug #10. (S).
- 84() Prepare *only one end* of an 11" green wire. Connect the bared end to SS lug #1. (S). This wire should pass lugs 12 and 11.
- 85() Carefully twist together the five long wires throughout their length. This group should come off the switch at lug 10.

Final Assembly

Set the front panel aside and prepare to wire the back panel. In the following steps reference will sometimes be made to pairs of *short* lugs on the input socket strips. These are located between the long lugs of the numbered sockets. These *short* lugs will be identified by a dashed number, as [#1-2], and connections are made to both, soldering them together when called for. The long lugs will be identified by a single number.

- 1() Prepare two 2" black wires. Connect one end of the first wire to *the pair of short* socket lugs #5-6. Connect the other end of this wire to *short* lugs #3-4. (S).
- 2() Connect one end of the second 2" black wire to *short* lugs #11-12. Connect the other end to *short* lugs #9-10. (S).
- 3() Select one of the .01 disc capacitors and trim the leads to no more than ¾". Connect one lead to *short* lugs #1-2. Connect the other lead to the adjacent ground lug on the upper bolt. (S).
- 4() Select the remaining .01 disc capacitor and trim the leads to no more than ¾". Connect one lead to *short* lugs #7-8. Connect the other lead to the adjacent ground lug on the upper left bolt. (S).
- 5() Prepare a 3" black wire. Connect one end to output lug #8. (S). Connect the other end to output lug #5.
- 6() Select the large 10 ohm, 10 watt resistor. Trim its leads to no more than ¾". Connect one lead to output lug #5. (S-2). Connect the other lead to output lug #1.
- 7() Prepare a 3" black wire. Connect one end to output lug #1. (S-2). Connect the other end to output lug #4.
- 8() Separate the two conductors at the end of the line cord for about two inches, and mark the cord with a pencil 3½" from the end. Strip ¼" of insulation from both wires *if necessary*, twist together the separate strands of each wire, and "tin" the end to prevent fraying. Bend the cord sharply back on itself at the pencil mark, and squeeze the bend with pliers to form a sharp "V". Install the strain relief

at the V as shown in detail B, with the small end of the strain relief nearest the bared wire ends. Use pliers to squeeze the two halves of the strain relief together around the wire, to partially shape the wire before insertion. Then grasp only the larger diameter part of the relief with the tips of the pliers as shown, squeeze it fully closed, and insert the bared wire ends and the strain relief from outside the back panel through the remaining hole in the panel. The strain relief will snap into its locked position when fully inserted.

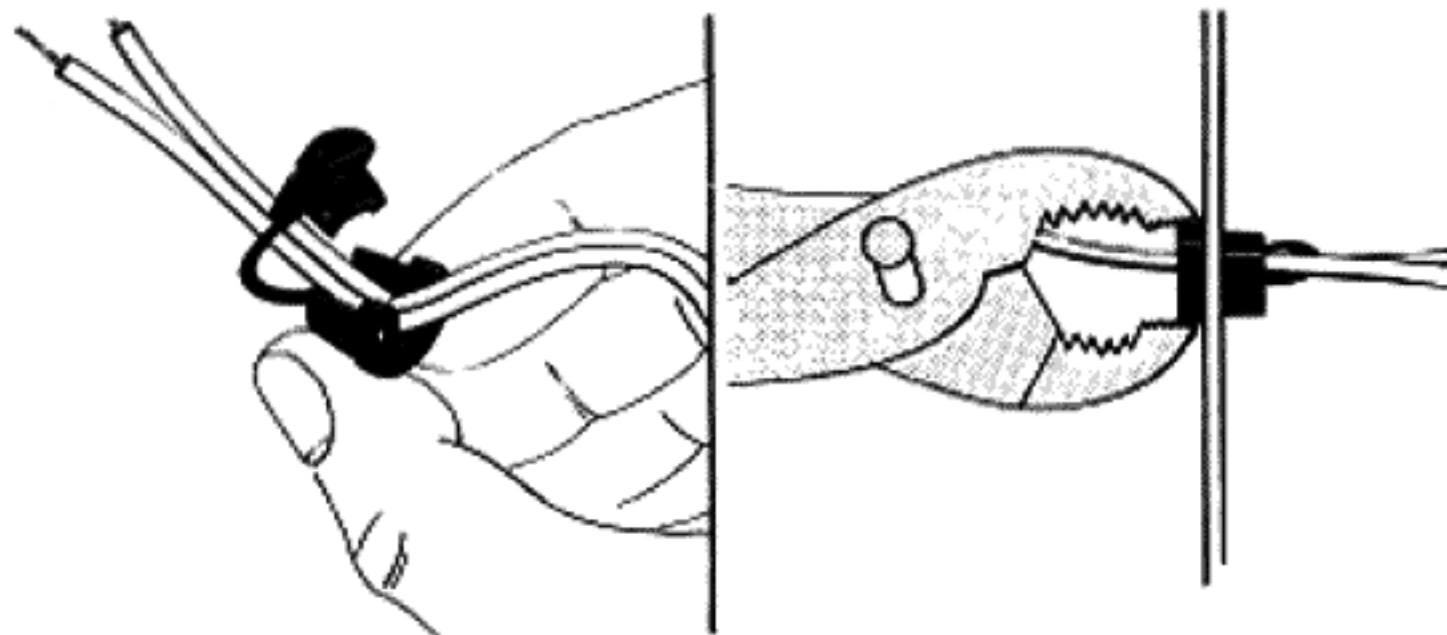

Detail B

- 9() Connect one of the two conductors of the line cord to AC outlet lug #2. Connect the other conductor to AC outlet lug #1.

Set the back panel aside and return to the main chassis.

- 10() Install the front panel with only two of the brass sheet metal screws in the *corner* holes only. Tilt the panel out for working. Place the 6 wires from OS and HP against the chassis between the power transformer and PC-19. The twisted groups of wires stay outside the edges of the chassis for now.
- 11() Unhook the wire from the clamp of C7R (the front capacitor) and connect the free end to HP lug #6. Loosen the clamp so you can take up slack in the coil by rotating the capacitor.
- 12() Prepare a 7" red wire. Connect one end to HP lug #6. (S-3). This wire can be wrapped around the lug if it will not fit through the hole in the lug. Make sure all connections are soldered.
- 13() Unhook the end of the coil around C7L from the edge of the chassis and connect the free end to HP lug #2. Loosen the clamp to take up the slack in the coil.
- 14() Prepare a 13" green wire. Connect one end to HP lug #2. (S-3).
- 15() As you tilt the front panel into its upright position, twist the capacitors C7L and C7R clockwise to keep the coils tight. Watch the short wires from the selector switch lugs 2, 4, 5 and 9 of each wafer. Those from the rear wafer go between the two preamplifier boards. Install two more brass sheet metal screws to hold the front panel rigidly. Tighten the clamps of C7L and C7R, making sure the capacitors are seated firmly to the chassis.

- 16() Select the long black wire (from OS lug 12) which has the hook in it and connect it up from underneath one of the ground lugs at the base of PC-19. (S-5). Make sure all of these wires to both ground lugs are well soldered.
- 17() Install the back panel with only two of the brass sheet metal screws in the corner holes, and tilt the panel out for working.
- 18() Select the long red wire with the hook in it (from OS lug 6) and connect it to output lug #6. (S).
- 19() Select the long green wire with the hook in it (from OS lug 2) and connect it to output lug #7. (S).
- 20() Twist together the two red leads from the power transformer. If you wish, the transformer leads may be shortened for neatness, but remember that the transformer warranty is voided if the leads have been cut too short for re-use. Be sure the bared ends are tinned. Connect one of the red leads to eyelet #9 of PC-19. (S). There is less risk of damaging the diodes on the board with excessive heat if the iron heats the eyelets from the rear of the board while the lead is inserted from the front. Make sure that all strands of each lead are soldered to the eyelet. Connect the other red lead to eyelet #8 of PC-19. (S). These red wires are on top of the three wires just connected. The remaining three go on top of the red wires, and will be connected later.
- 21() Select the black and red twisted pair from the power switch PS, place it around the power transformer and between the two AC outlets on the back panel. Connect the black wire to AC lug #3. Connect the red wire to AC lug #1. (S-2).
- 22() Select the black, red and green twisted group from PS, and place it around the power transformer. Connect the black wire to AC lug #4. Connect the red wire to AC lug #2. (S-2). Do not connect the green wire yet.
- The next 5 steps describe 120 volt AC wiring for the U.S. and Canada. Page 32 describes alternate wiring for other line voltages. If one of these is chosen, complete that wiring now in place of the following 5 steps. Transformer leads can be shortened for neatness, so long as no alternate use is likely. *Be certain all strands of a lead are twisted together and soldered to the lugs.*
- 23() Connect the green wire from the power switch to the top (side) lug #1 of the fuse holder.
- 24() Twist together the black and the black-white power transformer leads, and connect them both to the top (side) lug #1 of the fuse holder. (S-3).
NOTE: In Canada the fuse holder cap must be cemented in place, and a separate "pigtail" fuse installed, so do not solder this connection, and go to the NOTE in the next step.
- 25() Prepare a 1 $\frac{3}{4}$ " black wire. Connect one end to AC lug #4. (S-2). Connect the other end to tip lug #2 of the fuse holder. (S).
NOTE: In Canada select the pigtail fuse, trim its leads to $\frac{3}{4}$ ", and slide a $\frac{1}{2}$ " piece of insulating sleeving over each lead. Connect one lead to side lug #1 of the fuse holder. (S-4). Connect the other lead to AC outlet lug #4. (S-2). See separate pictorial diagram.

- 26() Twist together the violet and the violet-white transformer leads, and connect them both to AC lug #3. (S-3).
- 27() Twist together the green and the yellow transformer leads. Connect the green lead to TS lug #3. (S). Connect the yellow lead to TS lug #1. (S).
- 28() Select the twisted group of *five* wires from the selector switch *front* wafer, and connect them to the input sockets as follows: The stripped red wire to lug #9. (S). The stripped green wire to lug #10. (S). Strip $\frac{1}{4}$ " of insulation from the red and green wires remaining. Connect the red wire to lug #11. (S). The black wire to *short* lugs #11-12. (S-2). The green wire to lug #12. (S). Note the photograph on the following page which shows the placement of this group, and the other three groups from the selector switch.
- 29() Select the group of *three* twisted wires from the *front* wafer, and connect them to the input sockets as follows: The black wire to *short* lugs #7-8. (S-2). The red wire to lug #8. (S). The green wire to lug #7. (S).
- 30() Lift the twisted groups from the power switch near the top of the transformer so they will not be pinched, and tilt the back panel upright. Install two more brass sheet metal screws to secure the panel to the chassis.
- 31() Select the twisted group of *five* wires from the selector switch *rear* wafer, and connect them to the input sockets as follows: The stripped red wire to lug #3. (S). The stripped green wire to lug #4. (S). Strip $\frac{1}{4}$ " of insulation from the red and green wires remaining. Connect the red wire to lug #5. (S). The black wire to *short* lugs #5-6. (S-2). The green wire to lug #6. (S).
- 32() Select the group of *three* twisted wires from the *rear* wafer, and connect them to the input sockets as follows: The black wire to *short* lugs #1-2. (S-2). The red wire to lug #2. (S). The green wire to lug #1. (S).
- 33() Select the remaining long black wire from OS lug 11 and connect it to output lug #4. (S-2).
- 34() Select the long green wire from HP lug 1 and connect it to output lug #3. (S).
- 35() Select the long red wire from HP lug 7 and connect it to output lug #2. (S).
- 36() "Tin" the ends of all the wires on the chassis which are still unconnected, as this will simplify soldering them to the eyelets. Don't forget the short wires from lug 5 of each selector switch wafer. *Do not tin the lead of the 5 mfd capacitor on the rear wafer of the selector switch.*
- 37() Connect the red wire from HP lug 6 to eyelet #1 of the *front amplifier* board. (S). Place it down toward the chassis.
- 38() Connect the green wire from HP lug 2 to eyelet #1 of the *rear amplifier* board. (S). Place this wire toward the chassis and around the right heat sink.
- 39() Connect the short green wire from SS rear wafer lug 5 to eyelet #1 (forward) of the rear preamplifier board. (S).
- 40() Connect the black wire from SS rear wafer lug 9 (back) to eyelet #2 (forward) of the rear preamplifier board. (S).
- 41() Connect the green wire from SS rear wafer lug 2 to eyelet #5 (forward) of the rear preamplifier board. (S).
- 42() Strip a 1" piece of insulation from the black wire, and slip this insulation over the positive lead of the 5 mfd capacitor from SS rear wafer lug 4. Tin the end of the capacitor lead and connect it to eyelet #6 of the rear preamplifier board. (S).
- 43() Connect the short red wire from SS front wafer lug 5 to eyelet #1 (forward) of the front board. (S).
- 44() Connect the black wire from SS front wafer lug 9 (back) through the center of the switch to eyelet #2 of the front board. (S).
- 45() Connect the red wire from SS front wafer lug 2 to eyelet #5 of the front board. (S).
- 46() Connect the positive lead of the 5 mfd capacitor from SS front wafer lug 4 to eyelet #6 of the front board. (S). Make sure the bare leads cannot touch the control.
- 47() Select the short red and black twisted pair from BC, keep it above the green and black pair, and connect the red wire to eyelet #9 of the front board. (S). Connect the black wire to eyelet #10. (S).
- 48() Select the green and black twisted pair from BC, and keep it reasonably clear of the red and black pair. Connect the green wire to eyelet #9 of the *rear preamplifier* board. (S). Connect the black wire to eyelet #10. (S).
- 49() The six red wires of the DB and DT controls are connected to the front board as follows:
DB lug 3 to eyelet #13. (S).
DB lug 2 to eyelet #14. (S).
DB lug 1 to eyelet #15. (S).
DT lug 3 to eyelet #16. (S).
DT lug 2 to eyelet #17. (S).
DT lug 1 to eyelet #18. (S).
- 50() The six green wires of the DB and DT controls are connected to the rear preamplifier board as follows:
DB lug 6 to eyelet #13. (S).
DB lug 5 to eyelet #14. (S).
DB lug 4 to eyelet #15. (S).
DT lug 6 to eyelet #16. (S).
DT lug 5 to eyelet #17. (S).
DT lug 4 to eyelet #18. (S).

- 51() Prepare a 7" red wire. Tin both ends, and connect one end to eyelet #19 (back) of the front preamplifier board. (S). Connect the other end to eyelet #12 (forward) of the front PC-18 amplifier board. (S).
- 52() Prepare a 4 $\frac{3}{4}$ " green wire. Tin both ends, and connect one end to eyelet #19 (back) of the rear preamplifier board. (S). Connect the other end to eyelet #12 (forward) of the rear PC-18 amplifier board. (S).
- 53() Prepare a 7" green wire. Tin one end, and connect it to eyelet #7 (back) of the rear PC-18 amplifier board. (S). Connect the other end to the red lug of C7L. (S).
- 54() Prepare a 7" red wire. Tin one end, and connect it to eyelet #7 (forward) of the front PC-18 amplifier board. (S). Connect the other end to the red lug of C7R. (S).

This completes the wiring of your SCA-80Q. Check to see that there are no unattached wires and no unsoldered connections. Clip off any excessive stubs of wires to make a neat job. Check to make sure that the connections to each eyelet on the circuit boards show a smooth flow of solder from the wire to the circuitry. There are no connections to eyelets 7 and 8 of the preamplifier boards. If the unit was wired for 120 volt use, there will be no connections to lugs 2 and 4 of the rear panel lug terminal strip. Lug 2 is used only if a special grounded power cord is necessary.

Now turn the chassis over and shake out any bits of wire or solder. Check the twisted wires from the power switch to make sure they are not pinched by the chassis. Position the twisted groups of wires from the selector switch as shown in the photograph below. In particular, the groups from the rear wafer should be separated from the front wafer groups to preserve maximum channel separation. Be sure none of the leads from the front panel touch the front preamplifier board circuitry.

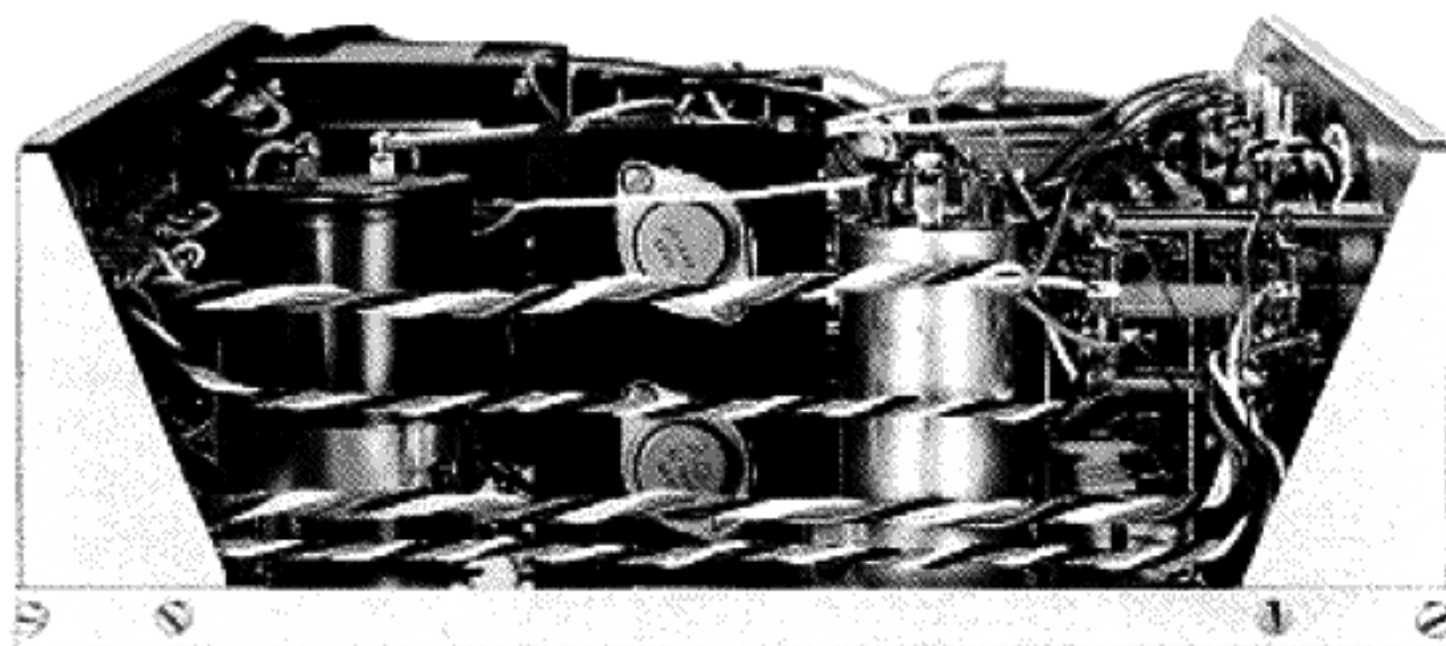

Check the resistor nearest the ground lugs on PC-19 to be certain that its lower lead cannot touch the chassis. Also make sure that no connecting wires are likely to

come into contact with any of the power resistors on PC-19, as these will get quite hot in normal operation. Check to see that red and green wires do not closely parallel each other unless they are twisted groups, or are connected to the same point. The parallel wires from OS and HP on the front panel to the outputs on the back panel do not matter. For best channel separation red and green wires should cross at right angles to each other.

General placement of wires should conform more closely to the photograph than to the pictorial diagram, which must necessarily be distorted to enable you to trace each wire. Make sure that wires which connect to the center lugs of C11 do not touch the outer ground lugs of the capacitor. Check the power switch to make sure there is no possibility of shorted connections between the lugs. The lead of the 5 mfd capacitor from the rear SS wafer should not be able to touch the bare wires between the preamplifier boards. The wires to the solder (ground) lugs on the heat sinks should not be able to touch the heat sinks or the cover when it is installed.

- 55() Insert a brass sheet metal screw into the back panel hole marked "GND". This is the point to which separate ground wires from the record player, etc. may be connected.
- 56() Insert the fuse into the fuse holder. (Skip in Canada).
- 57() Install the front plate, securing it with a $\frac{3}{8}$ " nut on shafts SS, BC and DT. Jack HP should protrude very slightly to avoid scarring the panel when plugs are inserted. If the plate does not seat properly, you can loosen the mounting hardware and shift a switch or control slightly.
- 58() The Allen head set screws are in a bag with an Allen wrench. Insert a screw into each knob, and position the large knobs on shafts SS and VC so that the set screw engages the flat on the shaft. The small knobs are positioned on the other shafts so that rotation is symmetrical to either side from top center.
- 59() Install the black thumb screws in the outer positions (marked "common") of the output terminal strips on the back panel. If they do not easily screw tightly to the panel, you should bend the small tab on the outside of the strip out of the way. Install the gold finish thumb screws in the remaining output terminals, and make sure they thread in fully.
- 60() Slide the cover on, and secure it with 5 brass sheet metal screws. The fifth screws into the top center of the back panel.

If you have not already done so, read the "Operating Instructions" before turning the amplifier on. Remember to connect the input and output leads to the amplifier before the power is turned on.

IN CASE OF DIFFICULTY

Your SCA-80 should function properly after assembly, and you can usually assume that if it functions to your satisfaction, it is meeting all of its specifications. Sometimes a wiring error, poor solder connection, or defective component may require trouble-shooting. Because 90% of the difficulties which are encountered in kit-built units can be attributed to incorrect wiring or a poor solder connection, it is strongly recommended that you ask someone else to check your wiring against the pictorial diagram, as frequently one person will make the same error repeatedly.

The SCA-80 has been carefully designed to provide exceptional accessibility for the serviceman. The average kit-builder should confine his servicing to the basic suggestions given here, after checking to make sure the fuse is intact. Audio transistors, unlike tubes, cannot be easily checked locally for any other than gross defects, and even this should be left to the qualified technician. For this reason your SCA-80 is considered to have "no user-serviceable parts inside."

Each of the 4 amplifier and preamplifier circuit boards, and all 4 power transistors have been in-circuit tested to assure that they meet specifications prior to shipment, so routine trouble-shooting can eliminate these as the source of the trouble, although they could have been subsequently damaged.

There are certain general precautions to be observed in servicing any transistorized equipment:

1. Never make circuit changes (connections or disconnections) of any kind when the amplifier is turned on.
2. Be particularly careful not to short any transistor leads to each other or to the chassis when the power is on.
3. When using test equipment, you must avoid transient voltage peaks and excessive test voltages.
4. Exercise caution when soldering and unsoldering transistor and diode leads to avoid excessive heat.

Check the connections at each eyelet along the edge of the circuit boards. There must be a smooth flow of solder from the wire, across the eyelet, onto the circuit board. If in doubt, reheat the connection and add more solder if necessary, but a lot of solder can conceal a poor connection. Look for flecks or splashes of solder on the circuit side of the board which may be causing unwanted connections. Make sure the large capacitors are seated firmly to the chassis, so that their lugs cannot contact the cover.

Check the selector switch to make sure that the two wafers are aligned, and that double lugs are soldered together. The #9 lug has separate front and rear sections with independent connections. Make sure the rear portion of this lug has not been twisted on the wafer. If difficulty is in the input to one channel, the selector switch deserves special attention. If you have no signal at all, check the *Monitor* and *Speakers* switches.

A systematic checking procedure will enable you to localize the problem area. A problem common to both channels is cause to suspect the power supply section, comprised of the line cord, power switch, fuse, power transformer, PC-19, C9 and C11.

If a VTVM (or TVM) is available, a voltage variation of more than 10% will help to pinpoint a problem. A higher than normal voltage at the collector of one of the transistors, for example, is possibly indicative that it is open and requires replacement. Voltages at the transistor leads, where shown, may vary $\pm 20\%$ and still be normal.

Power Supply

Measuring the AC voltage between eyelets 8 and 9 on PC-19 will check the power transformer. A defective rectifier or poor solder connection on the rectifier diode bridge may cause the power transformer to emit an audible mechanical vibration. The DC voltage measured across C9 will be about 75 volts if the rectifier diodes are functioning properly. The most likely cause for a blown fuse will be a shorted rectifier diode.

You may be able to isolate a fault in one power amplifier channel by removing the wire to one of the amplifier heat sinks from the red lug of C9. If the other channel then functions normally, the disconnected channel is suspect. Similarly, low voltage on a section of the C11 capacitor may indicate excessive current drain from one or the other channel, and disconnecting one board may localize the problem.

Power Amplifiers

It is possible to operate the SCA-80 monophonically in the event of difficulty with one power amplifier channel. The problem heat sink and circuit board assembly then may be removed from the circuit and returned to Dynaco for test and service by unsoldering 10 wires. For safety, these should be disconnected at the "far end" so that no unattached wires will be left in the amplifier. If you wish, the wires may be unsoldered from the assembly, and each insulated with electrical tape.

Do not return the circuit board alone unless you are certain that the output transistors and the power supply resistors R16 and R17 are performing normally and that the fault has not affected the preamplifier section. It is normal for the R16 and R17 resistors to run warm—in fact, they put out most of the heat from a normally functioning amplifier at average power levels—but if one runs much hotter than the other in the same channel, it indicates output transistor or diode failure. Excessive discoloration of any resistor also is a sign that it should be replaced.

When packing a circuit board and/or heat sink, be sure the packing adequately protects the board from damage, and protects the transistors so that their *leads are not bent or crushed*. Because the assembly is light in weight, it may be shipped by air if desired, saving a large part of the normal service delay time.

Preamplifiers—Tone Controls

A problem in the preamplifier section should include careful checking of the selector switch because it interconnects the low level preamp stages with the tone control sections. A systematic check can localize a problem in one channel to the preamp or tone control sections. For example, if there is insufficient output on the left channel phono input, see if this channel operates properly through the tuner input. If it does, the problem is in the low level section of the left channel. If there is no output from either left channel input, then the low level section can be tested with some ingenuity. If you realize that the "Tape Out" signal is available before the volume and tone controls, you can connect the left channel tape output into the identical input on the right channel as the program source you are using on the left channel. If you then have suitable signal level, the trouble lies in the left tone control section.

You can also interchange channels internally by connecting the output of the preamplifier (eyelet 19) to the opposite power amplifier input (eyelet 12).

Hum and Noise

The SCA-80 is inherently hum-free, and if any is detected, the inputs should first be unplugged. If there is no hum with the cables removed at the same volume setting as when the hum was noted, the problem must be corrected in the associated equipment. Sometimes the addition of a ground wire from the record player chassis or tone arm, or from a tape recorder, to the SCA-80 *Gnd* screw will eliminate hum, but it is generally advisable to use the fewest ground wires which achieve the desired result to avoid ground loops.

Some phono cartridges are more hum susceptible than others, and may not be suitable in certain installations where they are close to power transformers, AC power lines, etc. Sometimes simply placing the record player so that the cartridge is not so near any power transformer may alleviate the hum.

Hum which is common to both channels of the SCA-80 itself is almost certainly in the power supply. Be sure the cover is in place, however, for external fields will affect the results.

When there are no cables connected to the low level inputs, it is normal to have a high hiss level at high volume settings on Phono and Special. With sources connected, hiss should be inaudible at normally used volume settings, though some hiss may be evident at much higher settings of the volume control.

Beyond the most rudimentary checks, servicing of transistorized equipment should be left to the qualified technician. The SCA-80 needs no maintenance in normal use, and there are no adjustments required during the life of the amplifier. Improper servicing can impair its performance or damage it, so it is very important that the technician familiarize himself with the Circuit Description and with the Service Information which follows, before proceeding. Unless you are confident that a local repairman has the specialized knowledge and equipment for servicing high quality solid state audio equipment, *factory service is strongly recommended.*

SERVICE INFORMATION FOR THE TECHNICIAN

(FOR QUALIFIED PERSONNEL ONLY)

Before servicing the SCA-80, be sure to read the circuit description in the front of this manual, as well as the preceding section, for some of the amplifier's unique features may not be immediately apparent when examining this essentially simple circuit. A systematic check of voltages and signal paths, based on an understanding of the circuit, will lead to rapid diagnosis.

Preamplifiers—Tone Controls

The voltage chart does not specify voltages on the eyelets of the preamplifier boards because they are not significant, and may vary widely with individual transistors. If the problem is one of little or no signal, then simple signal tracing, following the signal path carefully and injecting some hum by touching each connection in turn is advisable. If there is a point after which hum occurs, and before which there is silence, you have located the trouble area.

The tone control potentiometers are of unusual construction, and cannot be measured by the usual continuity check. The bass control has a dual wiper, and the treble control has a discontinuous element.

Objectionable hiss at normal listening levels may be caused by a faulty Q7 transistor, unless it occurs on both channels. If there is hiss on both low level inputs of one channel, you can interchange Q7 with one of the other transistors, but return them to their original positions if this is not the trouble. The transistors in the tone control stages are not likely to be a source of objectionable hiss.

Amplifiers

The left and right audio channels are electrically identical. Each amplifier has two basic sections. The direct-coupled pair Q1 and Q2 is the Class A amplifier-driver with a DC feedback loop from the second emitter to the input base. Audio signals at the input base of Q1 are amplified and appear at the collector of Q2 to drive the four-transistor Class B power output section.

Q3 and Q4 are a complementary-symmetry driver directly coupled to Q5 and Q6 output power transistors. The Class B section provides a power gain, but no voltage gain. The input junction of Q3 and Q4, and the output junction of Q5 and Q6 swing together through the signal cycle. The ability of the output junction to follow the input junction (and the consequent linearity of this section) depends on the feedback path from the collector of Q6 to the emitter of Q4. Variations at Q4 emitter compared to its base potential will create a corrective signal for Q6, which makes the output follow the input.

Diodes D2 and D3 are in this feedback path, in a direction which would not be conductive (breaking the feedback path) were it not for the forced current through bleeder resistors R16 and R17. When the current in Q4 reaches that in R16 and R17, the diodes D2 and D3 no longer conduct, and the feedback path is broken. Simultaneously D1 starts conducting and makes a short circuit between the input of Q3 and Q4, and the output of Q5 and Q6.

Thus when the current demand in the feedback loop exceeds the limit determined by the bleeder resistors, the ability of the circuit to drive is restricted, and excessive currents cannot be induced in Q5 and Q6. The action of D1 short circuits the drive from Q2, reducing the drive until the cause of the high current demand is corrected. Thus an excessive drive signal, or too heavy a load on the output, which would require excessive current, switches the circuit to a configuration which prevents damaging current flow through the output and driver transistors.

Trouble-shooting the amplifiers

Any signs of scorched resistors or wire should be a basis for further investigation. If either R13 or R14 is burned, or smokes when the amplifier is on, then at least one of the transistors Q5 or Q6 and possibly Q3 or Q4 has been damaged, and replacement will be required. It must be emphasized that *if one of the transistors in the Class B section (Q3, Q4, Q5, Q6) is defective, the other three must be tested before proceeding further* to avoid possible repetitive breakdown. Resistors R16 and R17 on the power supply board normally get hot because of the reference bleed current. If only one of the pair is hot, Q5 or Q6 may be shorted, or D2 or D3 may be open. Heat observed under no signal conditions indicates excessive bias drop or oscillation (either internal, or from the source).

The voltage at the positive terminal of C7 should be about 36 volts (one half of the supply voltage). If this voltage is far off value, this can be a sign of trouble in one or more of the Class B transistors, and all should be checked.

If the voltage at the input bases of Q3 and Q4 is significantly different (more than 1.5 volts) from the voltage at C7, the voltage at the other end of C4 should be checked to determine if something is wrong in the Class A section, Q1 and Q2. A fault in either of these transistors can change the voltage at the collector of Q2 (input of C4), and this can be reflected in an incorrect potential at the bases of Q3 and Q4, which is further reflected in the junction of Q5 and Q6 (the positive terminal of C7). Voltages at either end of C4 may be inter-related when C4 is in the circuit. If one end of C4 is lifted, the voltage deviations from normal at either end will indicate whether a fault lies before or after C4.

It is unlikely that all voltages in the audio section are correct if there is no signal. However, if this condition occurs, it is most likely an open input capacitor C1, or coupling capacitors C4 or C7, or a shorted C2.

A signal which has some distortion, or is limited in power output, is more difficult to diagnose. See the section relating to performance tests. This requires a distortion analyzer and an oscilloscope to check the signal, and then routine signal tracing should locate the fault.

Checking transistors

An ohmmeter is all that is required to locate a transistor which has failed. Small transistors must be removed from the circuit board for test. The power transistors need not be removed from the heat sinks, but the wires to their terminals must be detached for measuring. All transistors can be considered (for this test procedure) to be two diodes connected in series with common elements tied together. The junction point represents the base of the transistor. The identification of the larger power transistors is shown in the photograph of each heat sink. The smaller ones, observed from the bottom, have the collector, base and emitter arranged counter-clockwise, with the collector attached directly to the case.

With one ohmmeter probe connected to the base, the other probe should be touched to the collector and emitter in turn. Readings from the base to the collector, and from the base to the emitter should be similar. With one orientation of the probes, there should be a high resistance reading (almost an open circuit). When the polarity of the probes is reversed, there should be a relatively low reading. The high reading will appear with one orientation of the probes for a pnp transistor, and with the opposite orientation for an npn transistor. Then the ohmmeter should be connected from collector to emitter, and a high resistance (almost open circuit) should be read, regardless of the orientation of the probes. If all of these qualifications are met, the transistor does not exhibit any gross defects. Qualitative evaluation of acceptable transistors requires equipment beyond the scope of local service facilities.

In similar fashion, diodes can be checked by verifying that they have a high resistance in one direction, and low resistance in the other.

When replacing transistors, the small ones with the finned radiators should have the radiators transferred to the replacement. The silicon grease between transistor and radiator should be transferred to the new transistor. Be careful to insert the leads into the proper eyelets. Do not use excessive heat on the leads—let the heat go to the eyelet instead. When replacing the power transistors on the heat sinks, maintain the mica insulator between the transistor and the heat sink. Spread some of the silicon grease, which is a heat transfer compound, between the mica insulator and the transistor, as well as between the heat sink

and the insulator. Be sure to use the nylon insulators around the mounting screws.

When making replacements, standard types can be used provided they are screened beyond the manufacturer's routine specifications. This is necessary because transistors of a given type vary far more widely than do tubes. The requirements for each transistor are given in the parts list with the schematic diagram. No screening will be necessary for transistors obtained from Dynaco if the application (Q-number) or the Dynaco part number is specified. If emergency needs require substitution of an unscreened transistor, the audio circuits will function but the effectiveness of the protective circuitry may be somewhat reduced. The Dynaco audio circuit has been designed so that no matching of transistors is required.

While the parts list does not show all of the possible transistor options, under no circumstances should unlisted transistors be used unless factory-approved in advance.

SERVICE POLICY AND LIMITED WARRANTY

The SCA-80Q has been designed to provide reliable, trouble-free operation for a long period of time when it has been properly assembled and installed. It incorporates unprecedented circuit protection against failure caused by abnormal operation. So conservative is its design that it will deliver specified performance with the maximum variations in AC line voltage (110 to 130) permitted in normal use.

Despite these precautions, service may sometimes be needed, and you should be sure to return the warranty card promptly to validate your warranty. Dynaco maintains a complete factory test and repair facility for which no return authorization is required. Unless specifically authorized in advance by the factory, Dynaco cannot assume any responsibility for local service charges. In addition to the factory, independent authorized service facilities are available in several U.S. cities and in Canada. Write Dynaco for the one nearest you.

A factory assembled SCA-80Q/A is warranted to be free of defects in materials and workmanship for a period of one year from the date of purchase. During the warranty period, no charge will be made for testing or servicing any defective factory assembled SCA-80Q/A returned to Dynaco.

All parts used in an SCA-80Q kit are warranted to be free of manufacturing defects for one year from the date of purchase. Defective parts will be replaced promptly at no charge upon receipt for inspection at the factory. After the warranty period has passed, Dynaco will supply any non-standard parts at net prices. Standard parts can generally be obtained from a local electronics supply store.

The warranty does not apply to other than the original purchaser, nor to units which have been subjected to neglect, abuse, misuse or accident.

If you suspect a defect in the power transformer, *the leads must be unsoldered, not cut* for its return. The warranty on the transformer is void if the leads have been cut too short for re-use.

If the kit has been completely assembled, yet does not function properly, or if difficulty develops after some use, Dynaco will service the SCA-80Q for a *nominal* charge. After one year, assembled units and kits are also subject to the same charge, plus the cost of parts.

As described elsewhere in this manual, the power amplifier circuit board assembly and related heat sink can be removed and returned for service *at the factory*. The labor

charge for each assembly will be nominal, plus the cost of out-of-warranty parts. The service charge for two such assemblies returned together will not exceed the service cost for a complete amplifier.

Once a complete SCA-80Q has been serviced by Dynaco for which a regular service fee was charged, a 90 day service warranty is given. No service warranty can be extended for individual circuit board assemblies.

Factory service is not available for kits which are incompletely wired, or kits wired with other than rosin core solder, or units physically or electrically modified or used contrary to the *Operating Instructions*, without prior factory authorization.

Technical assistance which may facilitate local diagnosis or service is available at no charge. Such assistance depends entirely on your description of the difficulty and any tests performed. Be as complete as possible.

The serial number of the amplifier which is on the cover of this manual should be mentioned in all correspondence, and whenever a part or the unit is returned to the factory.

When shipping the amplifier to Dynaco Inc. for service, include a note listing the symptoms, the name and address of the sender, and the serial number of the unit. Pack the unit securely to withstand the abuses of handling in transit. The complete original packing, if properly used, and in good condition, will be sufficient for Express or U.P.S. shipment. **PARCEL POST IS NOT A SAFE METHOD OF SHIPMENT, AND SHOULD NOT BE USED.** If no alternative is available, the unit must be double-packed with substantial packing between the cartons, and *it must be insured.*

Shipments should be made by insured prepaid Express or Motor Freight. Serviced units will be returned by Express or United Parcel Service, *collect* for all transportation and service charges, unless these charges have been prepaid.

Dynaco reserves the right to limit the service facility or the established service fees to two years from the date of purchase. Dynaco assumes no liability or responsibility for damages or injuries sustained in assembly or operation of this equipment.

PARTS LIST

Parts of similar type which do not change performance will sometimes be included as a matter of expediency. This will account for slight variations in value and appearance.

	PART #		PART #
1 Chassis bottom plate	711421		
1 Chassis front panel	711321		
1 Chassis back panel	711521		
1 Chassis cover	711021		
1 Transformer, power, 10490E	464019		
2 Circuit board assembly, amplifier, PC-18	557018		
2 Circuit board assembly, preamplifier, PC-17	556017		
2 Heat Sink, amplifier	769080		
2 AC outlet, black	351001		
3 Bracket, 2" diameter	717003		
1 Bracket, 1 3/8" diameter	717001		
2 Bracket, "U" shape	717012		
3 Capacitor, electrolytic, 5000 mfd @ 80 volts	284508		
1 Capacitor, electrolytic 3 section	294228		
1 Control, balance, 220 K dual	167224		
1 Control, bass, 50 K dual	167514		
1 Control, treble, 40 K dual	167404		
1 Control, volume, 250 K dual	177254		
1 Front plate, gold	769221		
1 Fuse holder, with hardware	341001		
1 Jack, phone	356021		
3 Knob, small	764185		
2 Knob, large	764186		
1 Line cord	322092		
5 Set screw for knob, Allen, 5-40 x 3/16"	613834		
1 Sleeving, insulating	893001		
2 Socket strip, 6 inputs	355007		
1 Switch, rotary, selector	334604		
1 Switch, rocker, lighted, power	334001		
2 Switch, rocker, DPDT (6 lugs)	334005		
2 Switch, rocker, DPTT (8 lugs)	337001		
1 Switch, rocker, QPTT (16 lugs)	366001		
2 Terminal strip, 4 screw	374005		
1 Terminal strip, 4 lug	374006		
2 Wire, #16 heavy gauge	319913		
1 Wire, hookup, black			
1 Wire, hookup, green			
1 Wire, hookup, red			
1 Wrench, Allen set screw, 5-40	968522		
1 Card, warranty			
1 Manual, instruction			
<i>Envelope #1</i>	997113		
		RESISTORS	
7 10,000 ohm (brown-black-orange)	113103		
2 18,000 ohm (brown-gray-orange)	113183		
1 8,200 ohm (gray-red-red)	113822		
1 4,700 ohm (yellow-violet-red)	113472		
2 120 ohm (brown-red-brown)	113121		
2 0.47 ohm (yellow-violet-silver) 2 watt	128004		
1 10 ohm 10 watt	120100		
		CAPACITORS	
		2 0.01 mfd disc	244104
		2 0.02 mfd disc	227203
		2 27 pf disc	244271
		2 0.01 mfd mylar dipped	265103
		2 0.022 mfd mylar dipped	265223
		2 3300 pf (.0033 mfd) tubular	265332
		2 5 mfd tubular electrolytic	283505
		<i>Envelope #2</i>	997101
		4 Foot, rubber	859001
		1 Fuse, 2 ampere, Slo-Blo	342020
		52 Lockwasher, #6	617305
		1 Lockwasher, 3/8"	617065
		4 Lug, ground	639308
		8 Lug, spade	620308
		29 Nut, hexagonal, #4-40	614245
		26 Nut, hexagonal, #6-32	614355
		9 Nut, hexagonal, 3/8"	614065
		33 Screw, machine, #4-40 x 1/4"	611245
		6 Screw, machine, #4-40 x 3/4"	611205
		26 Screw, machine, #6-32 x 1/2"	611385
		8 Screw, self-tapping, #6-32 x 3/8"	613365
		14 Screw, sheet metal, #6 brass	612339
		4 Spacer, tubular, 3/8", aluminum	660261
		2 Spacer, tubular, 1/2", brass	660021
		1 Strain relief, plastic	895001
		4 Thumb screw, black	623367
		4 Thumb screw, gold	623361
		1 Washer, flat, 3/8"	616165
		<i>Envelope #3</i>	957019
		1 0.01 mfd disc, 500 volt	228103
		1 Circuit board, PC-19	554019
		4 Resistor, 400 ohm, 7 watt, 5%	120401
		1 Resistor, 68 ohm (blue-gray-black)	103680
		4 Diode, rectifier, 3 amp, 200 prv	544322
		2 Bracket, right-angle	717011
		<i>Envelope #4</i>	947318
		2 Transistor, 2N3772, 571844 red dot	338-2
		2 Transistor, 2N3772, 571844	338-1
		4 Lockwasher, #6	617305
		4 Lug, ground	639308
		8 Nut, hexagonal, #6-32	614355
		8 Screw, machine, #6-32 x 1/2"	611385
		8 Shoulder washer/spacer, nylon	894001
		<i>Envelope #5</i>	967118
		4 Insulator, transistor, plastic	805001
		1 Thermal compound, capsule	945004

Do not remove the outer insulation from any of the three largest capacitors.

ALTERNATE AC LINE VOLTAGE CONNECTIONS

The power transformer supplied in the SCA-80Q has dual tapped primary windings which are connected in parallel for 100 or 120 volts, and in series for 220 or 240 volts. Assembled SCA-80Q/A amplifiers are connected for 120 volts unless this manual is stamped to indicate another voltage.

The 2 ampere slo-blo fuse supplied for standard 120 volt wiring or for the 100 volt option should be replaced with a 1 ampere slo-blo fuse when the amplifier is wired for 220 or 240 volt AC lines. The SCA-80Q is designed for use with either 50 Hz or 60 Hz current.

Steps 23 through 27 on page 25 of this manual describe the 120 volt connections. Optional connections are diagrammed and described below. In *all cases* the red and black wires from the power switch are connected to the red and black AC outlets as described in the instructions. The AC line cord is connected to the red AC outlet terminals. A wire connects AC outlet lug #4 to the tip of the fuse holder. The *black* transformer lead is connected to the top (side) lug of the fuse holder. No connection is normally made to lug #2 of the 4-lug terminal strip. It is provided in the event that a grounded 3-wire power cord is to be used.

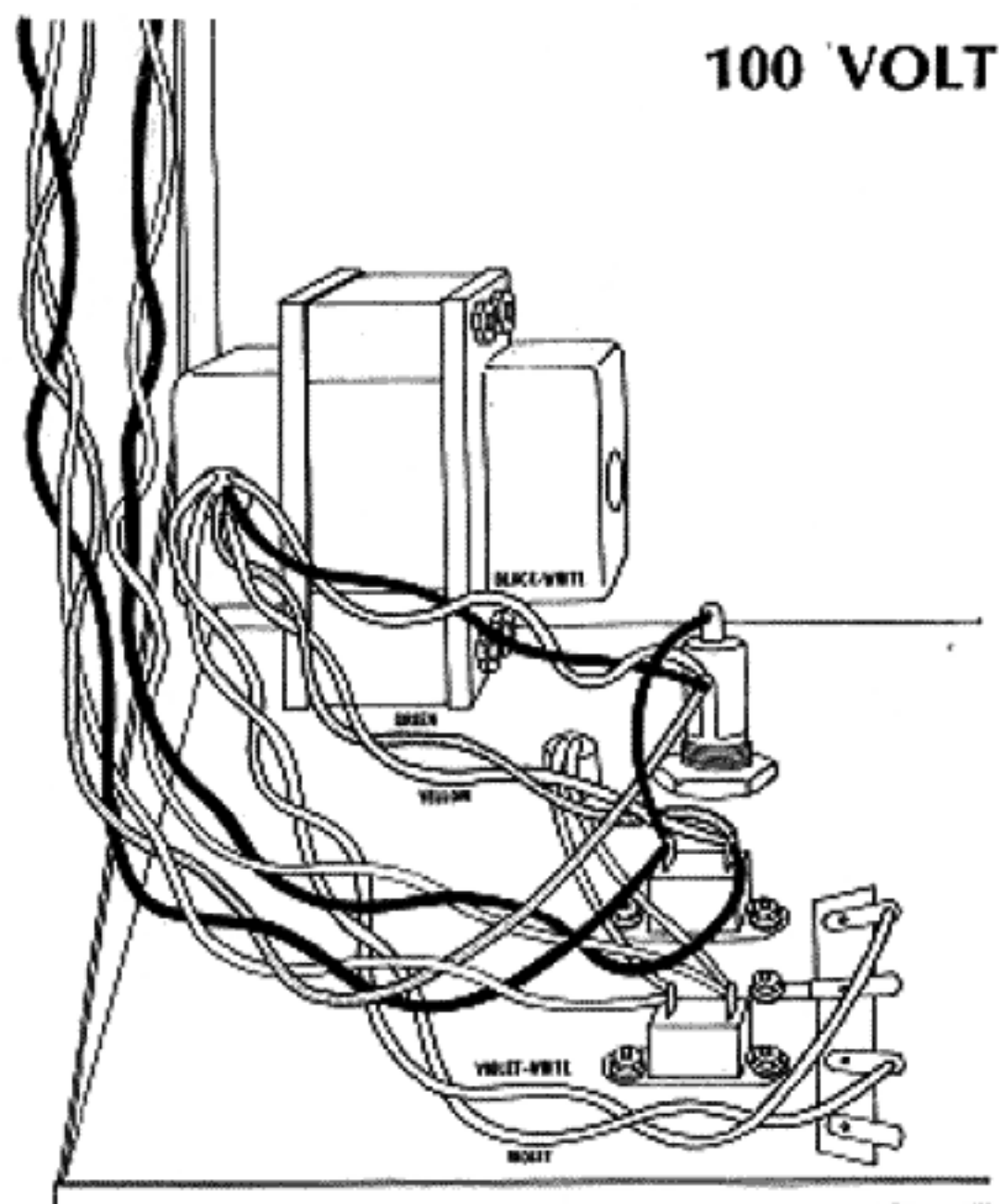

100 VOLT

100 volt AC line

Twist the black-white lead with the black lead and connect them both to the top (side) lug of the fuse holder. Connect the green wire from the power switch to the top (side) lug of the fuse holder. Twist the green and the yellow transformer leads together and connect them both to AC outlet lug #3. Twist the violet and the violet-white leads together and connect the violet lead to lug #3, and the violet-white lead to lug #1 of the 4-lug terminal strip.

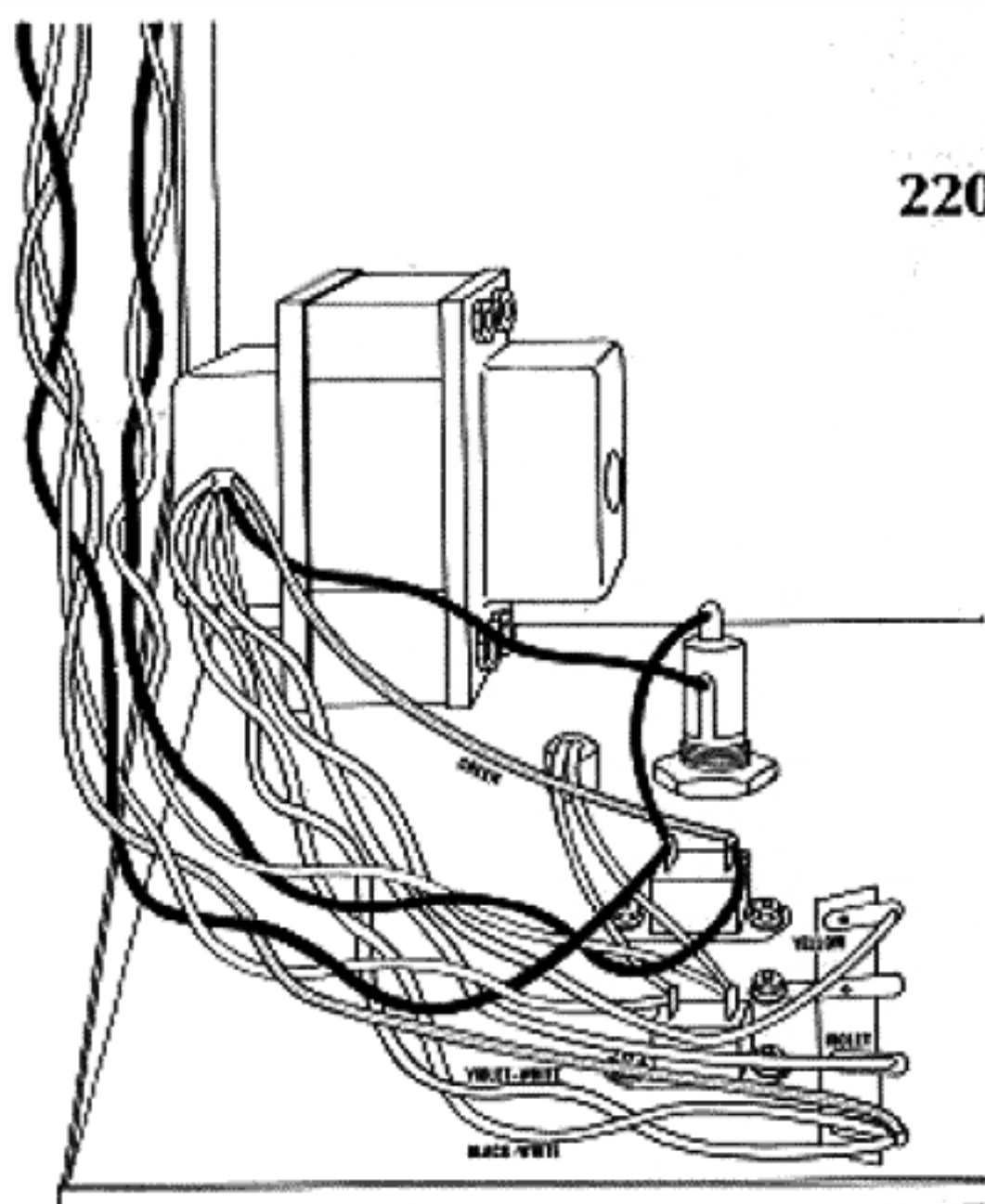

220 VOLT

220 volt AC line

Twist the violet-white and the black-white leads together and connect them both to lug #4 of the 4-lug terminal strip. Connect the green wire from the power switch to lug #4 of the 4-lug terminal strip. Twist the violet and the yellow leads together and connect the violet lead to lug #3, and the yellow lead to lug #1 of the 4-lug terminal strip. Connect the green transformer lead to AC outlet lug #3.

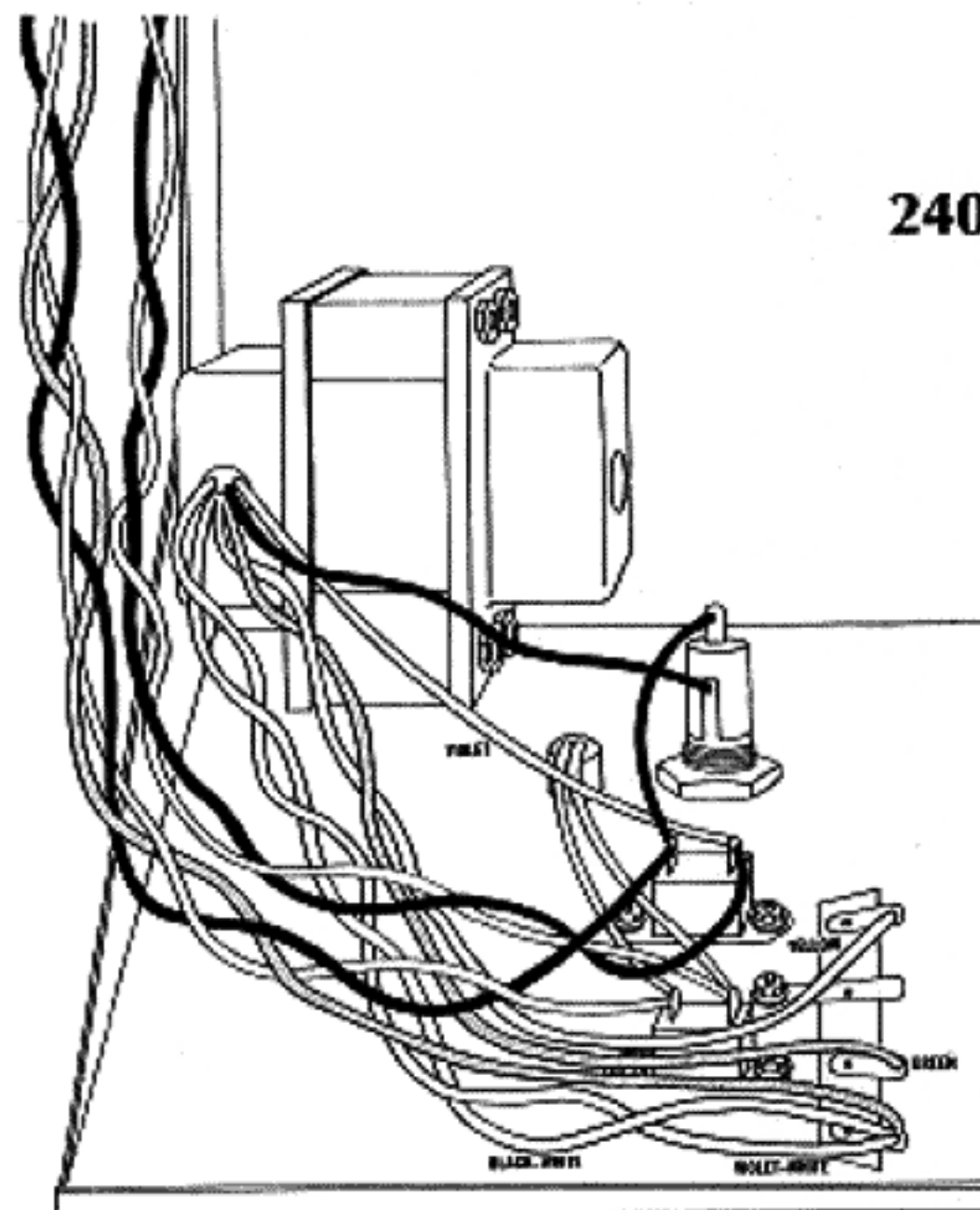

240 VOLT

240 volt AC line

Twist the violet-white and the black-white leads together and connect them both to lug #4 of the 4-lug terminal strip. Connect the green wire from the power switch to lug #4 of the 4-lug terminal strip. Twist the green and yellow transformer leads together and connect the green lead to lug #3, and the yellow lead to lug #1 of the 4-lug terminal strip. Connect the violet lead to AC outlet lug #3.